

## A THEORETICAL MODEL FOR DETERMINING THERMAL CONDUCTIVITY OF POROUS SOLID MATERIALS

\*Bicer Y.<sup>1</sup>, Yilmaz S.<sup>1</sup>, Devecioglu A.<sup>2</sup>, Ozdamar G.<sup>1</sup>

\*Author for correspondence

<sup>1</sup>University of Firat, Department of Mechanical Engineering, Elazığ, Turkey  
<sup>2</sup>University of Dicle, Department of Mechanical Engineering, Diyarbakir, Turkey  
E-mail: [ybicer23@gmail.com](mailto:ybicer23@gmail.com)

### ABSTRACT

In present study a new-developed simple algebraic equation is used to find out the effective thermal conductivity of new-produced composite materials that have non-homogenous microscopic porosity. Thermal power plant ashes, tragacanth and portland cement are used as binding components of these porous composite materials. By varying the mixing ratio of three components, 24 samples have been produced.

Effective thermal conductivity coefficients obtained by the algebraic method is then compared to the ones obtained by experimental measurement techniques. The theoretical results are found to be agreeable with the experimental results.

### NOMENCLATURE

|            |   |  |
|------------|---|--|
| $h/L$      | [-]   | Dimension ratio number   |
| $l$        | [-]   | Characteristic size of a pore                                  |
| $L$        | [-]   | Characteristic size of an elementary cell (particle diameter). |
| $k$        | [W/mK]  | Thermal conductivity   |
| $\phi$     | [%]   | Porosity   |
| $R$        | [m <sup>2</sup> K/W]                                      | Thermal resistance   |
| $T$        | [K]   | Temperature  |
| $\sigma$   | [5.67.10 <sup>-8</sup> W/m <sup>2</sup> K <sup>4</sup> ]. | Stefan-Boltzmann constant                                      |
| $\rho$     | [kg/m <sup>3</sup> ]                                      | Density  |
| Subscripts |   |  |
| $eff$      |   | Effective  |
| $s$        |   | Solid (material with zero porosity)                            |
| $g$        |   | Pore   |
| $eq$       |   | Equivalent   |

### INTRODUCTION

Porous systems can be conventionally divided into solid porous materials with define shape, granular materials and fibrous materials [1] Heat transport through complex and often dynamic porous materials is an essential requirement for modern technology such as high performance cryogenic insulation, heterogeneous catalytic reactors, construction materials and powder metallurgy, between others [2].

It is a known fact that the pore structure of materials has great influence on the thermal properties and therefore, deserves scientific interest. There have been many theoretical

and experimental studies on the thermal conductivities of the porous materials till now. For example, by assuming that the inner space is filled with empty spheres touching each other to form a tetrahedron shape, Luikov et al. [1] derived an equation for the porous dusts. They showed that the experimental results supported the equation in the 300-400 K temperature and 35-98 % porosity ranges. Wonchala and Wynnycykj [3] investigated the thermal conductivity of complex porous solids. They developed a model from the analogous diffusion model for predicting pore gas thermal conductivity.

Zumbrunnen et al. [4]. Developed a thermal conductance model for heat transfer in porous solids by using a probabilistically determined unit cell for a characteristic geometry. They designed an apparatus and used to measure overall thermal conductance (effective thermal conductivities) of several porous solids over a wide temperature range.

Additionally, they indicated that, when radiation is significant, overall thermal conductance increases with the temperature difference across the solid and is independent of thickness when the thickness is large relative to the pore size. Vysniauskas et al. [5] determined the thermal conductivity of insulating materials as ceramics by the hot-wire technique. Doğu et al. [6] introduced a new dynamic technique for the measurement of effective thermal conductivity and the Biot number for heat transfer, for porous solids. They reported that the new technique allows fast and precise determination of thermal conductivity of any porous solids. Dunlev et al. [7] studied the thermal conductivities of the humid porous materials. Biçer et al. [8] investigated some of the physical properties of natural rocks existing in six towns in Firat Basin in Turkey. Fu et al. [9] developed two unit cell-based models to predict the effective thermal conductivity of cellular ceramics. They found that the effective thermal conductivity decreases with porosity since the conductivity of the solid is usually much larger than that of the gas. Bouguerra et al. [10] carried out measurements of thermal conductivity, thermal diffusivity and heat capacity of highly porous building materials using transient plane source technique. Gonzo [2] developed correlating equations for the effective thermal conductivity of granular porous materials. Correlating equations encompassed a wide range of phase

conductivity ratio values and the comparison with experimental measurements showed very good.

The purpose of this work is to develop a theoretical expression related to the thermal conductivities and the porosities of the solids by a different approach.

**THEORY**

**Assumptions**

In this study;

- Because the diameters are smaller than 1 mm. the Rayleigh number ( $Ra=Gr.Pr$ ) is considered to be less than  $10^3$ . Heat transfer is assumed to be realized by conduction only and no natural convection is considered.

- The heat transfer by radiation is given according to the Stefan-Boltzmann Law with the equation  $q_r = \epsilon \cdot \sigma \cdot (T_1^4 - T_2^4)$ . Because the temperature gradient inside the wall is small, the heat transfer by radiation was neglected.

- Although the real porosities of the material have irregular spheres shapes, in the present model it is assumed that the porosities have regular squares shapes.

The effective heat transfer coefficient of porous solid materials is a function of porosity, the heat transfer coefficient of solid material and the heat transfer coefficient of gas in the pores etc.  $k_{ef}=f(\phi, k_s, k_g)$ .

Observing the cross-section of solid material, leads us to the physical model which is shown in Fig 1. A volume of the elementary cell in the model can be drawn as in Fig 2.

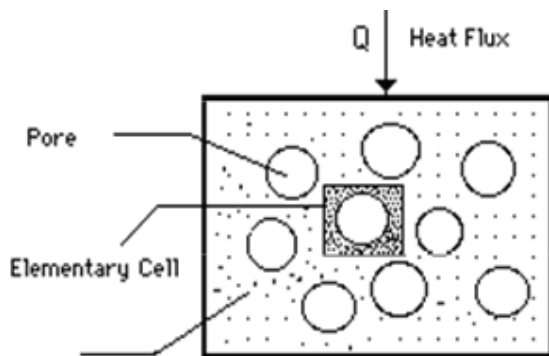

Solid Phase (Fly ash+tragacanth and cement)

**Figure 1** The physical model of porous material

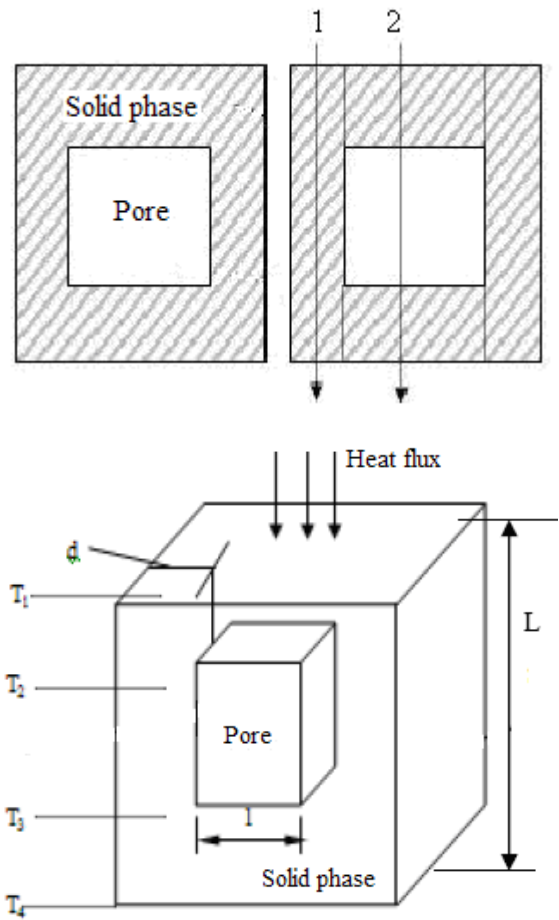

**Figure 2** Simulated structure of a cell

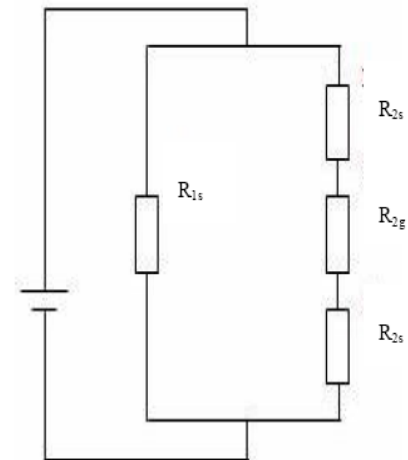

**Figure 3** Parallel + serial thermal resistance

As seen from Fig. 3, if the lines of the heat flow are assumed to be parallel to the vertical generating lines of the elementary cell, than thermal resistance of the components of the cell can be presented as:

$$R_{1s} = \frac{L}{k_s(L^2 - l^2)}, R_{2s} = \frac{d}{k_s.l^2} \text{ and } R_{2g} = \frac{l}{k_g.l^2}$$

The equivalent thermal resistance of the cell is:

$$\frac{1}{R_{eq}} = \frac{1}{R_{1s}} + \frac{1}{2R_{2s} + R_{2g}} \quad (1)$$

when the corresponding values of dimensions and conductivities are substituted into above equation,

$$\frac{1}{R_{eq}} = \frac{1}{\frac{L}{k_s(L^2 - l^2)}} + \frac{1}{\frac{2d}{k_s l^2} + \frac{1}{k_g l^2}} \quad (2)$$

where  $L-l = 2d = h$  or  $d = (L-l)/2$  and stands for the thickness of the pore wall. After substituting this and making some manipulation we obtain following equation:

$$\frac{1}{R_{eq}} = k_s L \left[ \left( 2\frac{h}{L} - \frac{h^2}{L^2} \right) + \frac{k_g \frac{(L-h)^2}{L}}{k_g h + k_s (L-h)} \right] \quad (3)$$

On the other hand, the equivalent thermal resistance of the cell may be expressed as a function of effective thermal conductivity of the cell:

$$\frac{1}{R_{eq}} = \frac{L}{k_{ef} L^2} = \frac{1}{k_{ef} L} \quad (4)$$

If this relation and Eq.(3) are combined, the following relation can be obtained:

$$k_{ef} = k_s \left[ \frac{h}{L} \left[ 1 + \left( 1 - \frac{h}{L} \right) \right] + \frac{\left( 1 - \frac{h}{L} \right)^2}{\frac{k_s}{k_g} \left( 1 - \frac{h}{L} \right) - \left( 1 - \frac{h}{L} \right) + 1} \right] \quad (5)$$

For the physical model assumed, pore volume/total volume ratio (porosity) is:

$$\phi = (L-l)^3 = \left( 1 - \frac{h}{L} \right)^3 \quad (6)$$

From this we may get:

$$\frac{h}{L} = 1 - \phi^{1/3} \quad (7)$$

If Eq.(7) is substituted into Eq.(5), the following equation is obtained:

$$k_{ef} = k_s \left[ 1 - \phi^{2/3} + \frac{\phi^{2/3}}{\phi^{1/3} \left( \frac{k_s}{k_g} - 1 \right) + 1} \right] \quad (8)$$

where  $k_s$  represent the thermal conductivity of the solid material with no pores. The  $k_s$  values of samples were determined from experiments.  $k_g$  is the thermal conductivity of the gas in the pores which is taken as 0.0214 W/mK. The porosities of the samples were determined by using density method [11]. They were given in Table 1.

### Sample solution

Sample 8: Component; %10 cement, %90 fly ash, %0.5 tragacanth. Porosity ( $\phi$ ): 0.3145,  $k_s$  (solid phase): 0.323 W/mK,  $k_g$  (Pore): 0.0214 W/mK.

$$k_{ef} = 0.323 \left[ 1 - 0.3145^{2/3} + \frac{0.3145^{2/3}}{0.3145^{1/3} \left( \frac{0.323}{0.0214} - 1 \right) + 1} \right] = 0.188$$

Effective thermal conductivities of the samples were determined by using Eq.(8) and presented in Table 1.

### EXPERIMENTAL STUDY

As previously told, the fly ash used in the experiments were supplied from *Afsin-Elbistan Thermal Power Plant*. Mixture of tragacanth and Portland cement were used as binding materials. The new samples were produced by varying the kind and percentage of cement and tragacanth (Fig. 4). The new productions were subjected to tests to find out their thermal conductivity coefficient.

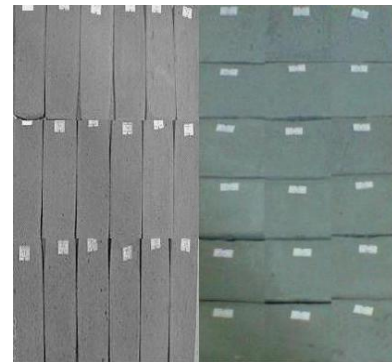

Figure 4 New-prepared samples

A *shotherm-QTM unit (Showa Denko)* which runs based on the hot wire methodology of *DIN 51046* was used to measure the thermal conductivities of the specimens. Its range and sensitivity were 0.02-10 W/mK and  $\pm 5\%$  of its scale respectively [12]. The measurements on three locations of each sample block were repeated three times to reflect the average of nine values.

## RESULTS AND CONCLUSIONS

The values of thermal conductivities that are determined experimentally and theoretically are listed in Table 1. The comparisons of the calculated and the experimental results of heat transfer coefficient samples are given Fig. 5.

The values of thermal conductivities that were determined experimentally and theoretically are listed in Table 1.

It is evident in the Table that, when the cement ratio is below 20%, the theoretical and experimental values of thermal conductivities are nearly similar. Above the %20 cement ratio, the theoretical values increases and becomes quite higher than the experimental values. This major result is also shown in Fig.5. both of the Fig.5, and Table 1 improves the suitability of theoretical model to determine the conductivity.

Fig. 5 also improves that the presence of tragacanth in the material causes to decrease the thermal conductivity. It is to say that, the tragacanth can be used as a binder in the insulation material because of this exact result.

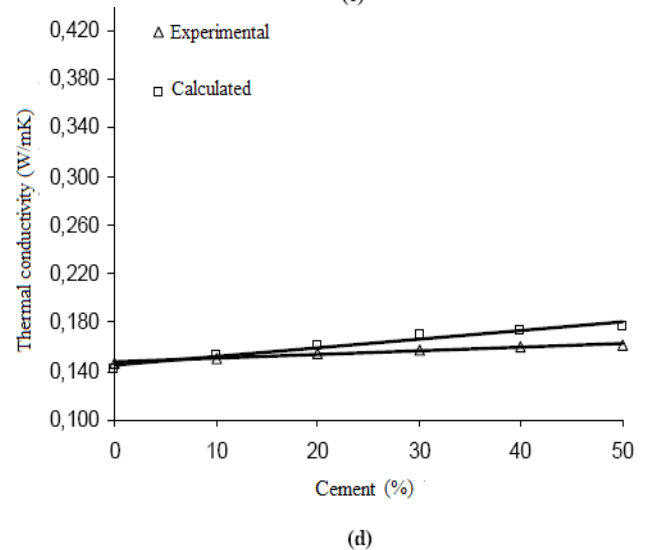
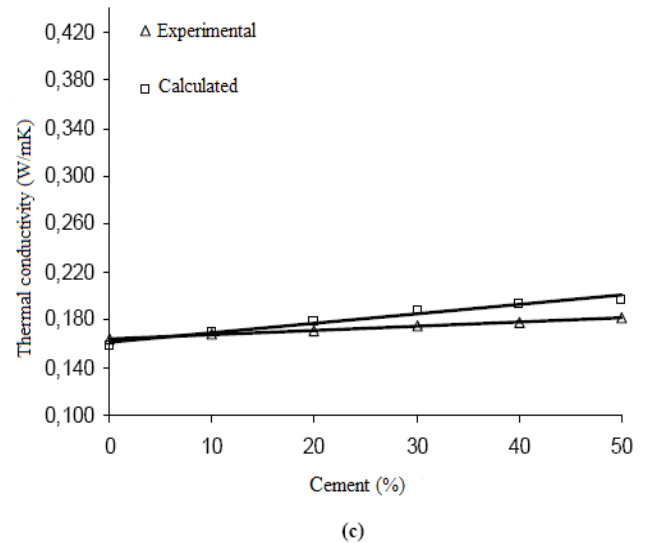
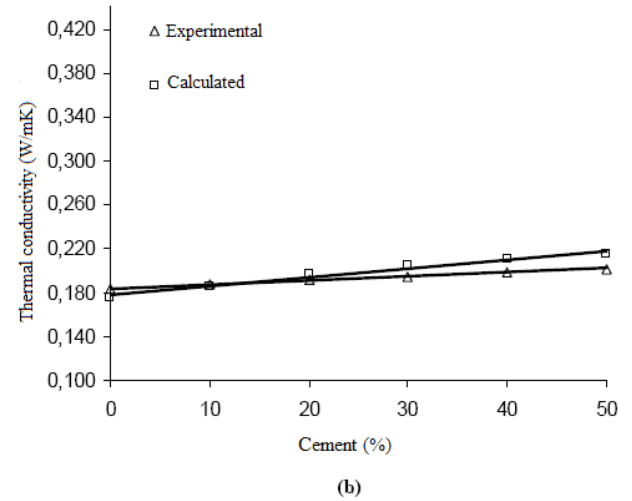
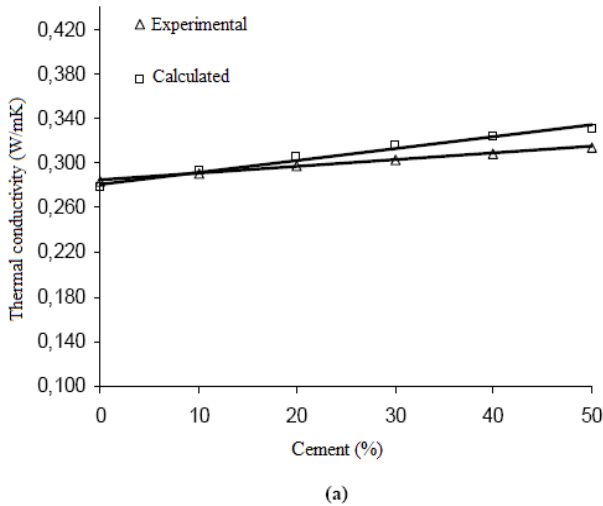

**Figure 5** The comparison of the calculated and experimental results of heat transfer coefficient of the fly ash specimens a) 0.0% tragacanth, b) 0.5% tragacanth, c) 1.0% tragacanth, d) 1.5% tragacanth.

**Table 1** Some properties of samples which were predicted by calculations and found by experiments

| Sample no | Tragacanth weight (%) | Cement weight (%) | Density (g/cm <sup>3</sup> ) | Porosity (%) | k <sub>predicted</sub> (W/mK) | k <sub>experimental</sub> (W/mK) |
|-----------|-----------------------|-------------------|------------------------------|--------------|-------------------------------|----------------------------------|
| 1         |                       | 0                 | 1.23                         | 0.33         | 0.284                         | 0.278                            |
| 2         |                       | 10                | 1.28                         | 0.3145       | 0.291                         | 0.293                            |
| 3         |                       | 20                | 1.33                         | 0.3004       | 0.297                         | 0.305                            |
| 4         | 0                     | 30                | 1.39                         | 0.2875       | 0.303                         | 0.315                            |
| 5         |                       | 40                | 1.44                         | 0.2757       | 0.309                         | 0.324                            |
| 6         |                       | 50                | 1.49                         | 0.2648       | 0.314                         | 0.331                            |
| 7         |                       | 0                 | 1.09                         | 0.33         | 0.183                         | 0.175                            |
| 8         |                       | 10                | 1.16                         | 0.314        | 0.188                         | 0.187                            |
| 9         |                       | 20                | 1.20                         | 0.3004       | 0.192                         | 0.197                            |
| 10        | 0.5                   | 30                | 1.25                         | 0.2875       | 0.195                         | 0.205                            |
| 11        |                       | 40                | 1.30                         | 0.2757       | 0.199                         | 0.211                            |
| 12        |                       | 50                | 1.33                         | 0.2648       | 0.202                         | 0.215                            |
| 13        |                       | 0                 | 0.98                         | 0.33         | 0.164                         | 0.158                            |
| 14        |                       | 10                | 1.06                         | 0.3145       | 0.168                         | 0.17                             |
| 15        |                       | 20                | 1.12                         | 0.3004       | 0.171                         | 0.179                            |
| 16        | 1                     | 30                | 1.17                         | 0.2875       | 0.175                         | 0.187                            |
| 17        |                       | 40                | 1.22                         | 0.2757       | 0.178                         | 0.193                            |
| 18        |                       | 50                | 1.27                         | 0.2648       | 0.181                         | 0.197                            |
| 19        |                       | 0                 | 0.86                         | 0.33         | 0.147                         | 0.142                            |
| 20        |                       | 10                | 0.96                         | 0.3145       | 0.151                         | 0.153                            |
| 21        |                       | 20                | 1.03                         | 0.3004       | 0.155                         | 0.162                            |
| 22        | 1.5                   | 30                | 1.09                         | 0.2875       | 0.158                         | 0.169                            |
| 23        |                       | 40                | 1.16                         | 0.2757       | 0.160                         | 0.174                            |
| 24        |                       | 50                | 1.21                         | 0.2648       | 0.162                         | 0.177                            |

## REFERENCES

- [1] Luikov A. V., Shashkov A.G., Vasiliev L.L. and Fraiman E., Thermal conductivity of porous systems. *International Journal of Heat and Mass Transfer*, 11, 117-140, 1968.
- [2] Gonzo E. E., Estimating correlations for the effective thermal conductivity of granular materials. *Chemical Engineering Journal*, 90, 299-302, 2002.
- [3] Wonchala E. P. and Wynnckj J.R., The effective thermal conductivity of solids with complex pores in the transition and Knudsen regions. *The Canadian Journal of Chemical Engineering*, 62, 719-722, 1984.
- [4] Zumbrennen D. A., R. Viskanta and Incopera F.P., Heat transfer through porous solids with complex internal geometries. *International Journal of Heat and Mass Transfer*, 29, 275-284, 1986.
- [5] Vysniauskas, V. V. Zikas A.A. and Zaliauskas A.B., Determination of the thermal conductivity of ceramics by the hot-wire technique. *Heat Transfer Soviet Research*, 20, 1, 137-142, 1988.
- [6] Dogu G., Mürtezaoglu K. and Dogu T., A dynamic method for the effective thermal conductivity of porous solids. *AIChE Journal*, 35, 4, 683-685, 1989.
- [7] Dulnev G. N., Volkov D.P. and Malarev V.I., Thermal conductivity of moist porous materials. *Journal of Engineering Physics and Thermophysics*, 56, 2, 281-290, 1989.
- [8] Bicer Y., Tanyildizi V., Pehlivan D. and Yildirim, S. A research on the physical features of the natural building materials available in Firat basin. *Çukurova University Journal of Faculty of Engineering and Architecture*, 8, 2, 53-60, 1993.
- [9] Fu X., Viskanta R. and Gore J.P., Prediction of effective thermal conductivity of cellular ceramics. *International Communications in Heat and Mass Transfer*, 25, 2, 151-160, 1998.
- [10] Bouguerra, A. Ait-Mokhtar A., Amiri O., Diop M.B., Measurement of thermal conductivity thermal diffusivity and heat capacity of highly porous building materials using transient plane source technique. *International Communications in Heat and Mass Transfer*, 28, 8, 1065-1078, 2001.
- [11] Bicer Y., Pihtili K. and Ayhan T., A theoretical model for the calculation of thermal conductivity of porous materials. *Journal of Thermal Sciences and Technology*, Turkey, 14, 4, 25-30, 1991.
- [12] Yilmaz S., Evaluation of Thermal Power Plant Ash in Tragacanth Binder Combinations as a New Construction Material, *Ph.D. thesis*, Firat University, Elazig, Turkey. 2010.