



# CAPTIVE /

THE LIFE OF OUR STATIC BUILDINGS

## Author

Philippus Rudolph Botha

## Study Leader

Nico Botes

## Course Leader

Jacques Laubscher and Arthur Barker

## Research Field

Heritage and Cultural Landscapes

Submitted in partial fulfilment of the requirement for the degree  
Magister in Architecture (Professional)  
Department of Architecture  
Faculty of Engineering, Built Environment and Information Technology  
University of Pretoria

Pretoria  
2012

In accordance with Regulation 4(e) of the General Regulations (G.57) for dissertations and theses, I declare that this thesis, which I hereby submit for the degree Master of Architecture (Professional) 6 at the University of Pretoria, is my own work and has not previously been submitted by me for a degree at this or any other tertiary institution.

I further state that no part of my thesis has already been, or is currently being, submitted for any such degree, diploma or other qualification.

I further declare that this thesis is substantially my own work. Where reference is made to the works of others, the extent to which that work has been used is indicated and fully acknowledged in the text and list of references.

-----  
Philippus Rudolph Botha

## Project Summary /

### **Programme /**

Interpretative Archive

### **Site description /**

The Union Buildings

### **Users /**

South Africans, the greater public of Pretoria and international tourists.

### **Site Location /**

Erf 357-JR, Arcadia

### **Address /**

Government Avenue, Arcadia, Pretoria, South Africa

### **GPS Coordinates /**

25°44'28.18'S, 28°12'42.27'E

### **Architectural Theoretical Premise /**

The relationship between architecture and the craft of making

### **Architectural Approach /**

Developing a new public programmed intervention on the site of the Union Buildings

*for /*

Wolfgang Strack

German Master Builder and friend

1933 - 2012

I have no theoretical approach towards architecture,  
I am not interested in the abstract thinking,  
what interests me is the making of the real.

-Peter Zumthor

## HYPOTHESIS /

Reintroducing a public programme to the Union Buildings in order to commemorate the centenary of this Sir Herbert Baker masterpiece, by exploring the relationship between architecture and the craft of making / building / the material dimension.

## ABSTRACT /

This research project investigates the possibility of a public programme-overlay at the Union Buildings, situated on Meintjieskop on the western edge of the Pretoria inner city. The design of the Buildings was commissioned to Sir Herbert Baker to celebrate the newly formed Union of South Africa in 1910.

The buildings were completed in 1913 and this research project attempts to commemorate the centenary of this landmark. The buildings' current state does not allow for public participation and this seems unfortunate for both the public and the buildings.

This dissertation attempts to reintroduce the Union Buildings to South Africans, the Pretoria public as well as international tourists by recording the memory of the buildings. The intervention is an interpretative archive to the life of the Union Buildings. The static, stereotomic nature of the buildings has ironically been shaped and forced into many different symbolic meanings through the ever-changing political and cultural dynamics of South Africa. The life of the buildings has been interpreted into five distinguishing symbolic-eras: Birth, Union, Oppression, Democracy and Power. The new intervention attempts to make these layered eras public.

This project will also explore the relationship between architecture and craft. This study understands that architecture is more than ever becoming a two dimensional experience and this is believed to be a direct result of the dimension in which it is explored - between pen and paper. The investigation will contest this current condition in which architecture finds itself. Moreover the focus of this study will be to explore architecture in its final dimension, thus exploring the relationship between architecture and craft.

In the true sense this is a study of the tekton.



## ACKNOWLEDGEMENTS /

This treatise is dedicated to The One who made matter and to His best work, my wife.

## CONTENTS /

Hypothesis	viii
Abstract	ix
Acknowledgements	x
Preface	xiii
List of Figures	xiv

## THOUGHT /

01 Theoretical Departure	- Introduction	10
	- Tectonic Form	10
	- Atmospheres	12
	- Normative Position	14
	- Conclusion	14

## ANALYSIS /

02 Setting	- Introduction	18
	- Historical Landscape	18
	- Romantic Landscape	20
	- Working Landscape	22
	- Site Analysis	26
03 Intervention	- Introduction	30
	- The Site	30
	- Aims and Objectives	31
	- The Programme	32
	- The Discovery	34

04	Precedent Studies	- Introduction	36
		- The Work of Carlo Scarpa	36
		- The Models of Peter Zumthor	38
		- The Christmas cards of Thomas Heatherwick	39
		- Rachel Whiteread	40
		- Mémorial des Martyrs de la déportation	42

## EXPLORATION /

05	Design Development	- Exploring through Drawing	46
		- Exploring through Material	47
		- Design Progression	52
06	Technical Resolution	- Introduction	70
		- Tekton Approach	71
		- Material Strategy	72
		- Progress Drawings	74
07	Conclusion	- Representational Drawings	82
	Bibliography		102

## PREFACE /

This document serves as a recording of a dissertation. It not only serves as a platform for the representation of ideas but also as structured guidance to the author. It should be read as a critical and form giving part to this study. The document is divided into three sections to achieve clarity in both the study and its representation.

Section One, 'Thought', focuses on the manner in which the author believes architecture should be conceived. This section deals with the thinking before the physical making of an object - the distance between the mind and the eye.

Section Two, 'Analysis', consists of the study of the place and the setting. This section deals with the analysis of the physical object and its memory, whether it be a landscape or a case study of similar interest - the distance between the object and the eye.

Section Three, 'Exploration', deals with both the experiment of making an object and the refinement of that object - the distance between the eye and the hand as well as the distance between the hand and the object.

# LIST OF FIGURES /

## 01 | Theoretical Departure

- Fig. 1.1** Parti diagram of theoretical departure (2012).
- Fig. 1.2** Diagram illustrating relationship between hand and object (2012).
- Fig. 1.3** Construction drawing of Mies van der Rohe (Moma, 2010).
- Fig. 1.4** Construction drawing of Carlo Scarpa (Bagnoli, 2006).

## 02 | Setting

- Fig. 2.1** Panoramic view from Union Buildings (2012).
- Fig. 2.2** Romantic views of the Union Buildings (2012).
- Fig. 2.3** Photographs of romantic views (2012).
- Fig. 2.4** Thomas Baines, Pretoria from Meintjeskop (Baker, 1909).
- Fig. 2.5** View from Meintjeskop (Claus Schutte, 2009).
- Fig. 2.6** Urban armature study model (2012).
- Fig. 2.7** Church Street surface study (2012).
- Fig. 2.8** Video stills of Awakening and Doze off (2012).
- Fig. 2.9** Site Analysis Explosion Diagram (2012).
- Fig. 2.10** Locality Plan (2012).
- Fig. 2.11** Site Sketches (2012).

## 03 | Intervention

- Fig. 3.1** Site concept diagram (2012).
- Fig. 3.2** Site development diagram (2012).
- Fig. 3.3** Time-concept diagram (2012).
- Fig. 3.4** Programme diagram (2012).
- Fig. 3.5** Discovery vignettes (2012).

## 04 | Precedent Studies

- Fig. 4.1** Carlo Scarpa drawings ([www.prattinteriordesign.blogspot.com](http://www.prattinteriordesign.blogspot.com)).
- Fig. 4.2** Models by Zumthor ([www.zumthor.tumblr.com](http://www.zumthor.tumblr.com)).
- Fig. 4.3** Christmas cards ([www.dezeen.com](http://www.dezeen.com)).
- Fig. 4.4** House, East London, 1993 ([www.damonart.com](http://www.damonart.com)).
- Fig. 4.5** Water Tower, Soho, New York, 1998 ([www.damonart.com](http://www.damonart.com)).
- Fig. 4.6** Untitled Monument, Trafalgar Square, London, 2001 ([www.telegraph.co.uk](http://www.telegraph.co.uk)).
- Fig. 4.7** Mémorial des Martyrs de la déportation ([www.po-l.com](http://www.po-l.com)).

## 05 | Design Development

- Fig. 5.1** Tekton exploration drawings (2012).
- Fig. 5.2** Concept model drawings (2012).
- Fig. 5.3** Concept model (February, 2012).
- Fig. 5.4** Painting of the Bank of England by Joseph Gandy, 1830 ([www.hughpearman.com](http://www.hughpearman.com)).
- Fig. 5.5** Surface recording device (2012).
- Fig. 5.6** Detail wax model (2012).
- Fig. 5.7** Embossing stands (2012).
- Fig. 5.8** Early conceptual work (March) (2012).
- Fig. 5.9** Urban intention diagram (2012).
- Fig. 5.10** Site responsive explosion diagram (2012).
- Fig. 5.11** Site responsive diagram (2012).
- Fig. 5.12** Development of site plan (April, 2012).
- Fig. 5.13** Site model at 1:1000 (2012).
- Fig. 5.14** Carving of site model (2012).
- Fig. 5.15** Preliminary Plan (June, 2012).
- Fig. 5.16** Preliminary Section (June, 2012).
- Fig. 5.17** Basement Plan development (July, 2012).
- Fig. 5.18** Basement Spatial exploration (July, 2012).
- Fig. 5.19** Ground Floor Plan development (August, 2012).
- Fig. 5.20** Basement Plan development (August, 2012).
- Fig. 5.21** Section development (August, 2012).

## 06 | Technical Resolution

- Fig. 6.1** Conceptual drawing (May, 2012).
- Fig. 6.2** Tekton Conceptual Diagram (2012).
- Fig. 6.3** Material relationship (2012).
- Fig. 6.4** Material Palette (2012).
- Fig. 6.5** Development of the stone memorial (August, 2012).
- Fig. 6.6** Detail A- development (September, 2012).
- Fig. 6.7** Detail A- representation model (October, 2012).
- Fig. 6.8** Detail B- development (September, 2012).
- Fig. 6.9** Detail B- representation model (October, 2012).
- Fig. 6.10** Detail C- development (September, 2012).
- Fig. 6.11** Detail C- representation model (October, 2012).

## 07 | Conclusion

- Fig. 7.1** Locality Plan (2012).
- Fig. 7.2** Site Plan (2012).
- Fig. 7.3** Ground Floor Plan (2012).
- Fig. 7.4** Basement Plan (2012).
- Fig. 7.5** Section CC (2012).
- Fig. 7.6** Section BB (2012).
- Fig. 7.7** Section DD (2012).
- Fig. 7.8** Section EE (2012).
- Fig. 7.9** Section FF (2012).

---

All figures by author unless stated otherwise  
All figures not to scale unless stated otherwise

## 01 | Theoretical Departure

**THOUGHT /**





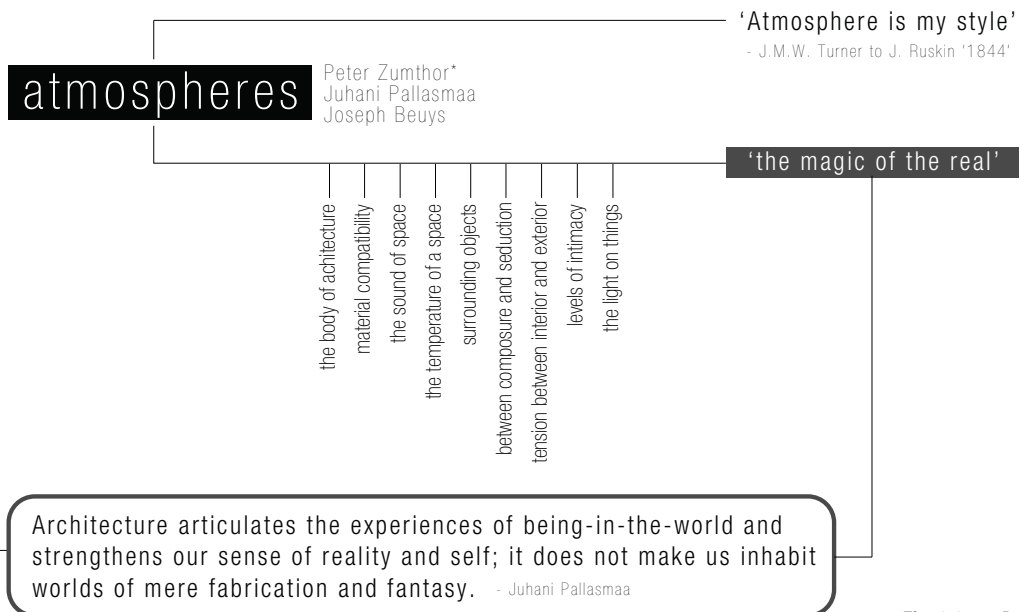


Fig. 1.1 *Parti diagram of theoretical departure*

## Atmospheres

The architecture of the 2009 Pritzker Prize Winner, Peter Zumthor, is one which is preoccupied with material, scale and the third dimension from a very early stage in the design process. From the beginning, the design process is focused on the architecture and the exploration also happens within this dimension.

Zumthor refers to this exploration in his book *Atmospheres: Architectural Environments - Surrounding Objects*, and here he discusses the nine points that he considers in his exploration of architecture. All of these points are concerned with the final resolution of the built form and therefore intensely focused on the material aspect of the space defining object.

Zumthor further explains that architecture is ultimately about coherence- the idea of things coming into their own, that all the parts present are vital to the composition and any more parts will destroy the whole (Zumthor, 2006:38).

Fig. 1.2 illustrates that the relationship between the hand and the object is the focus of the exploration. The extensions of the hand are explored until a seamless relationship is achieved between the extension and the wanted object.

The nine points which Zumthor (2006:37) considers in order to achieve a certain atmosphere in his buildings are:

- 1/ **The body of architecture**  
Each material has its own presence; this does not only refer to different types of material but also to the way its surfaces are treated.
- 2/ **Material compatibility**  
The way in which different materials can either be in harmony or in contention with one another. This is not only due to the volume of the material but also the way in which it is joined.
- 3/ **The sound of space**  
This idea does not refer to the sound of a space due to its programme but rather the sound which all the materials create in their new composition.
- 4/ **The temperature of space**  
Being similar to the sound of space, the temperature is perceived as a result of the reflection or absorption of materials in that space.
- 5/ **Surrounding objects**  
This idea refers to the harmony between the building and its surrounding objects.
- 6/ **Between composure and seduction**  
This focuses on the programme in relation to the articulation of materials in order to influence rather than direct the user.
- 7/ **Tension between interior and exterior**  
When architecture is built interior space is formed within existing exterior space. The treatment of the threshold between the two spaces is what is being referred to here.
- 8/ **Levels of intimacy**  
The proximity and distance between the human body and the built; the human interaction with different scales of the built.
- 9/ **The light on things**  
The way in which materials and non-materials are rendered by both natural and artificial light.

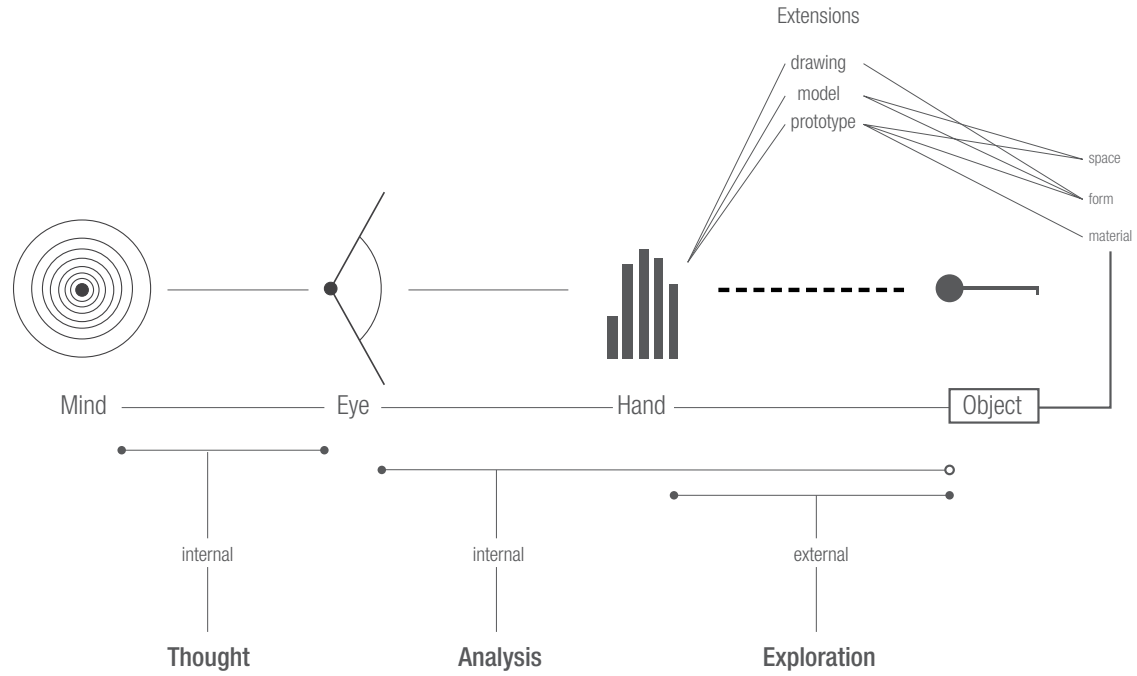


Fig. 1.2 Diagram illustrating the relationship between hand and object

## Normative Position

In the author's view architects are responsible for the joining of parts to create a whole.

However my feeling is that many architects are more concerned with making a whole that is merely kept together by the parts. The parts are no longer part of the whole, they have become the engineer's problem to keep the architect's beautiful 'whole' from resisting gravity.

A whole is made up of parts and parts are made up of smaller parts.

Take the idea of a closed room. You approach the door and open it. The way this door opens is an essential part of how you will experience the room (the whole). The door might swing forward by pushing it, or backwards by pulling it. The way the door swings again influences the way the handle needs to be designed. The door is a part of the room and the handle a part of the door. The door also has more than one swing, the swing away from the frame and the swing of the hinged connected side of the door. Does the hinge reveal light from the inside of the room? The hinge is a part of the door, but also a whole on its own.

**To me this is the thing of building that excites me: the joining of parts; the joining of wholes; the joining of materials.**

## Conclusion

Ludwig Mies van der Rohe had no academic training in architecture, yet he was a master builder. His father, a master mason and stonecutter, introduced him to the built environment. His architecture mostly consisted of steel structures and glass. He was a master at hiding details and distilling connections to plain simple lines. He was a Modernist.

Without his inherent understanding of materials and connections he would not have been able to produce the seamless architecture that he did. His buildings have become beautiful monuments but I am not sure whether they interest me on a detail level, at least not from photographs. His detail drawings may be complex and difficult to achieve but the experience of the architecture becomes sterile, in that it is mostly about space.

The celebration of the joinery has been hidden from the user and the complexity has been reserved only to the section-drawing literate.

In my mind the marriage of materials should be celebrated honestly. Without ornamentation to the outside or the inside to hide the construction.

Although I admire Mies' absolute understanding of materials and construction, I believe in a different construction, one which is celebrated, not hidden.

In my opinion the details of Carlo Scarpa are celebrated. He had a vast understanding of materials and connections. In my mind the single aspect that most influenced his work was his constant presence on site. He would solve the details on site with the people building it.

**Scarpa could not have been more intimate with the construction of the building, and that, I believe, is the secret to making great architecture.**

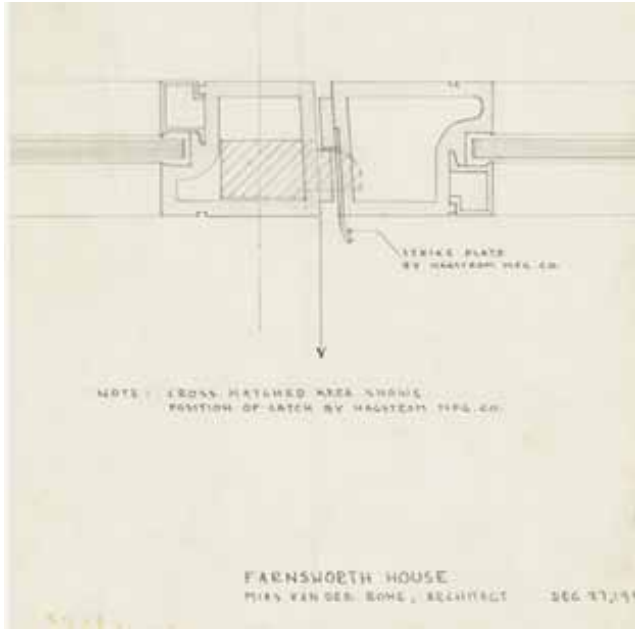


Fig. 1.3 Construction drawing of Mies van der Rohe

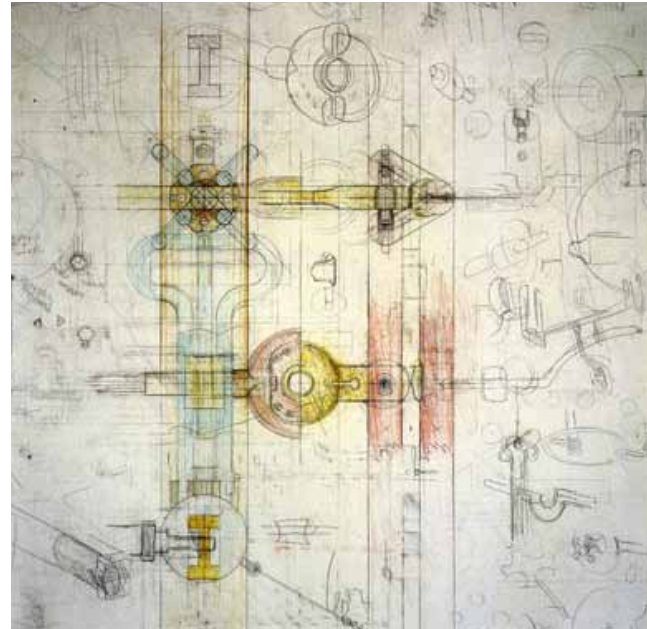


Fig. 1.4 Construction drawing of Carlo Scarpa

02 | Setting

03 | Intervention

04 | Precedent Studies

# ANALYSIS /



## SETTING /02

### Introduction

The current relationship between the public and the Union Buildings is one that is distilled down to the ocular experience, similar to that of a painting. In this sense the buildings become a two dimensional surface to the public and do not allow for tactile exploration. The buildings, conceived and built in a time when architecture was greatly explored in the tactile dimension, have fallen into a state similar to that of the exploration of current architecture.

The life of the buildings has been minimised to the unexpected romantic views it offers from the city, thus a pure ocular experience.

### Historical Landscape

The Union Buildings sit on Meintjieskop, a historical eminence on the north-eastern edge of the Pretoria city. In the 1890's the koppie also served as a shale quarry as building materials were needed for expansion to the east (Andrews,1989:16). The basements of the Union Buildings are partly placed in these old stone quarries and are therefore, throughout almost on solid rock.

The buildings were commissioned in 1909 by the State of South Africa to celebrate the New Union (the Union governed from 1910-1960). The original site proposed by the State was that on which the City Hall stands today, but the architect, Sir Herbert Baker, convince them to select the site on Meintjieskop. This choice of site was probably influenced by the painting of the famous artist, Thomas Baines, *Pretoria from Meintjieskop* painted in 1872 (Fig. 2.4: page 22). The idea the architect had was to design an acropolis for South Africa and rendered the site a natural place for such monumental architecture (Botha, 1989:1).

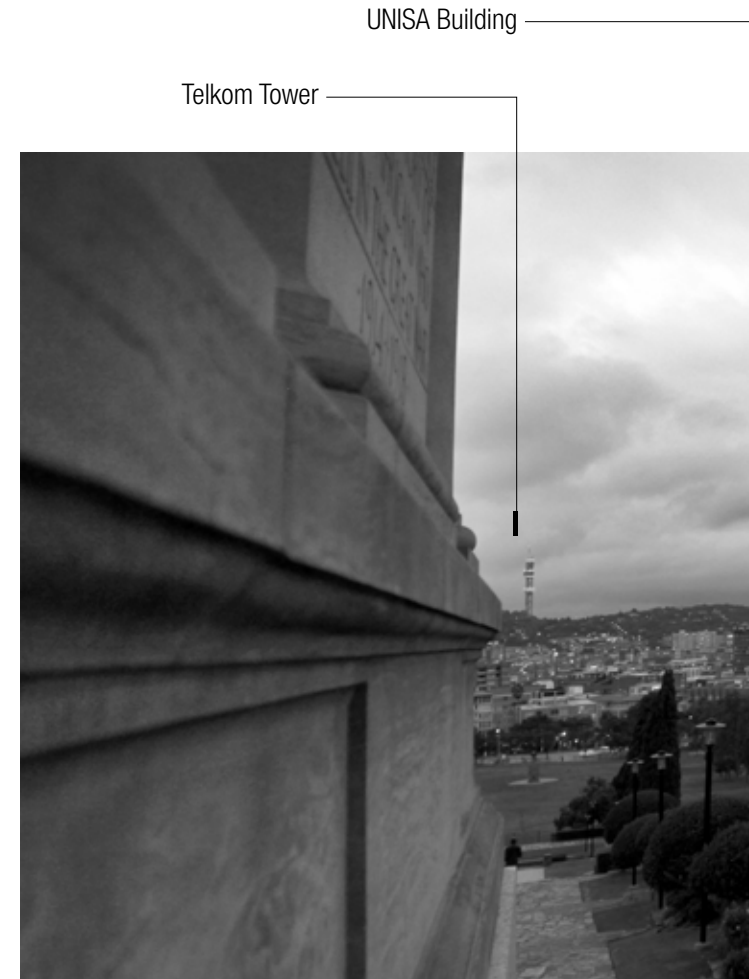




Fig. 2.1 *Panoramic view from Union Buildings*

## Romantic Landscape

The term romantic landscape refers to the almost picturesque views one has of the Union Buildings throughout the city of Pretoria. These views have a majestic and silent feel about them and one almost experiences the buildings as a painting.

The original idea was that the buildings would be framed when entering the city through the Fountains Valley (Unknown, 1910:6). The development around the Fountains Valley and Sunnyside did not take this view into account and today the buildings cannot be seen from this city portal. Although this initial view could not have been sustained in the build up of the city fabric, new unexpected views were formed. These unexpected views are mapped in Fig. 2.2 and represented in fig 2.3 on the opposite page.

This analysis could serve as a framework for the positioning of temporary pavilions in the future.



Fig. 2.2 Romantic views of the Union Buildings



a  
View from Struben Street



b  
View from Government Avenue



c  
View from Queen Wilhelmina Avenue



d  
View from Leyds Street



e

View from the Gautrain between Pretoria station and Hatfield station

Fig. 2.3 Photographs of romantic views

## Working Landscape

The term working landscape refers to a more intimate scale of the city where activity and change is visible. The first scale is focused around two anchor points in the city: Church Square and the Union Buildings.

The painting of Thomas Baines from Meintjeskop in 1872 (Fig. 2.4) shows the relation between the kop and Church Square as well as the prominence of the kop to the city. In my opinion the kop serves as witness to the development of Pretoria.

The idea of an acropolis for South Africa, which Sir Herbert Baker had in mind, is evident in the adjacent painting, with ample space between Meintjeskop and the city. The city has since overgrown the kop and the buildings find themselves in a completely different environment today. The surrounding urban fabric did not respond well to the buildings despite Sir Herbert Baker's efforts to ensure the buildings future.

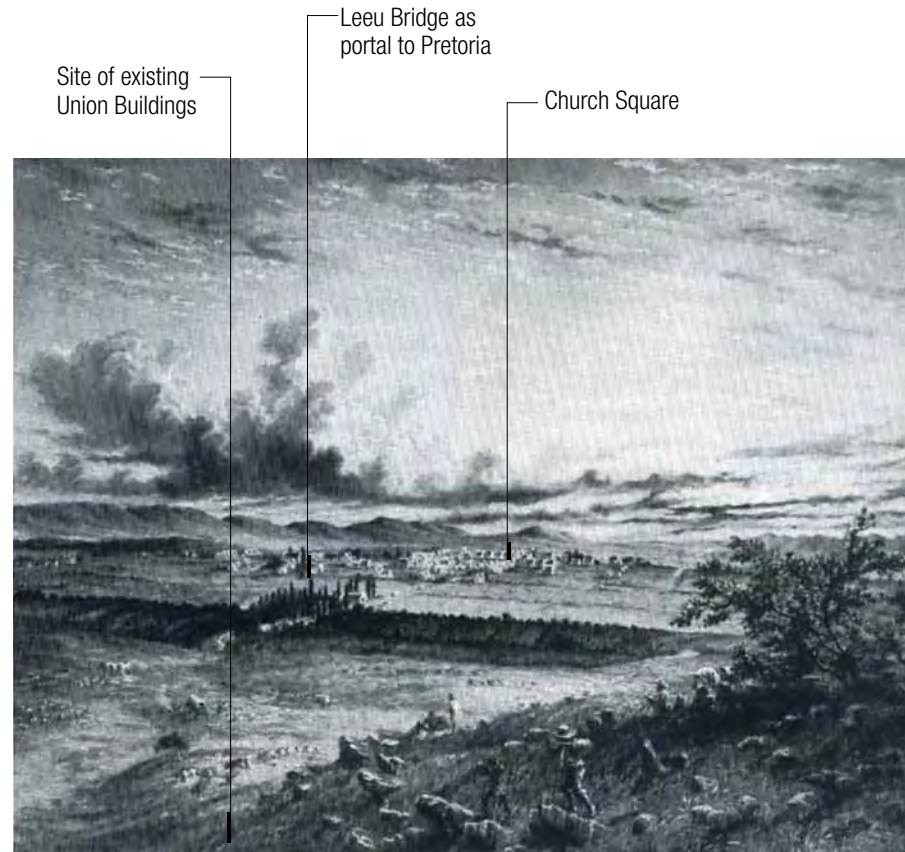


Fig. 2.4 Thomas Baines, *Pretoria from Meintjeskop*



Fig. 2.5 *View from meintjeskop*

An armature study (a study of urban space arranged on an axis between two key attractions) of Church Street between Church Square and the Union Buildings was conducted to investigate the relationship between the street and the road.

The study clearly shows the lack of urban spatial response in Church Street to the Union Buildings. The street does not attempt to introduce the buildings and the edge is simply treated with a fence. The north-south axis of the buildings is also not acknowledged and the entrance to the site is poorly defined. Twenty eight cross sections were taken on Church Street and a physical model was built in order to represent the findings.

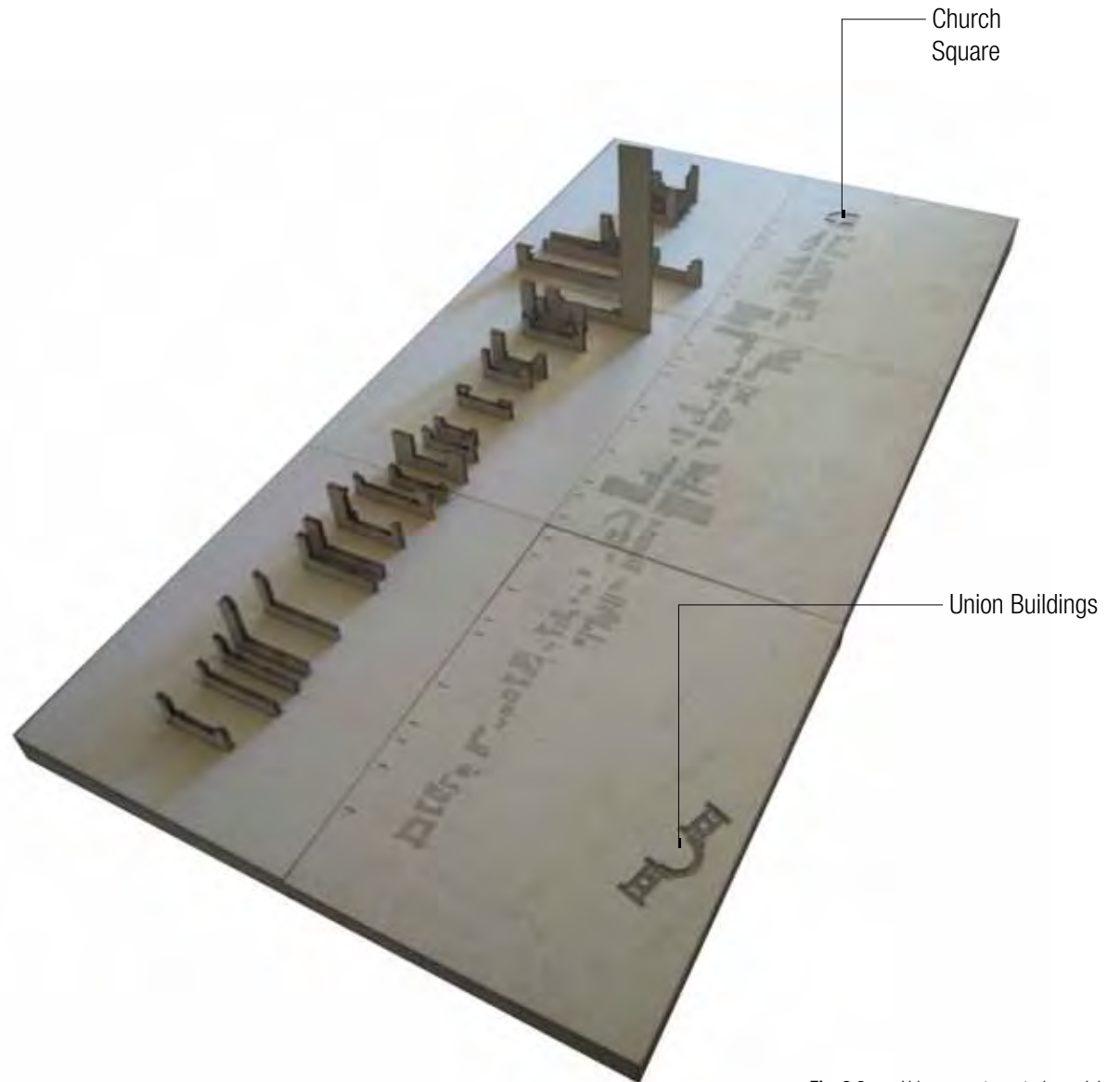


Fig. 2.6 Urban armature study model

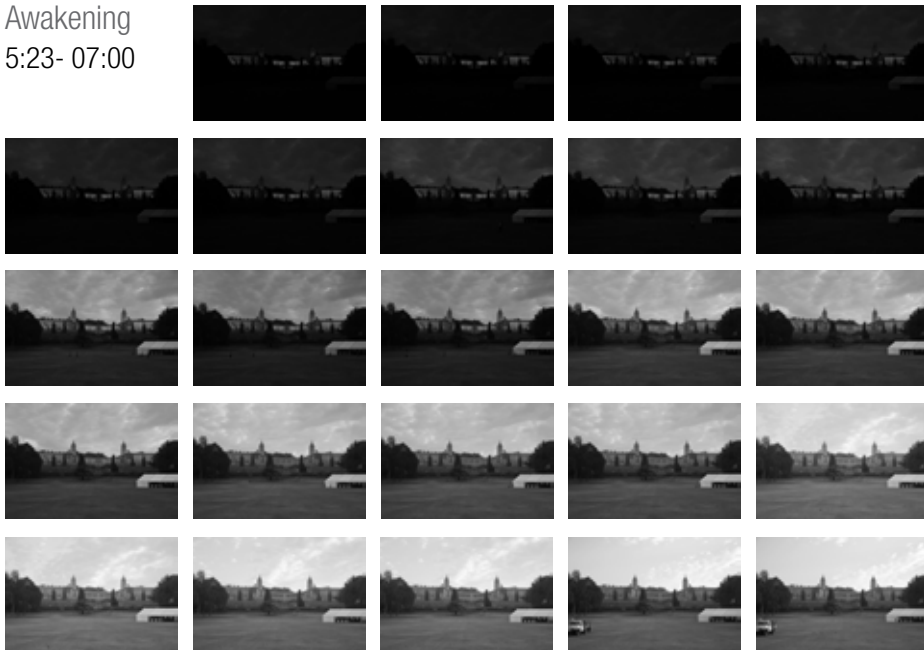
A further investigation concerning surface quality was executed by making pencil embossed recordings of the vertical boundaries within the armature study area. The embossed recordings were taken on each of the twenty eight sections at different heights of public boundaries. These recordings can now serve as a mnemonic device to frequent city users and also give others a sense of the condition or quality of the public edge/boundary. The findings of this exercise are illustrated in Fig 2.7.



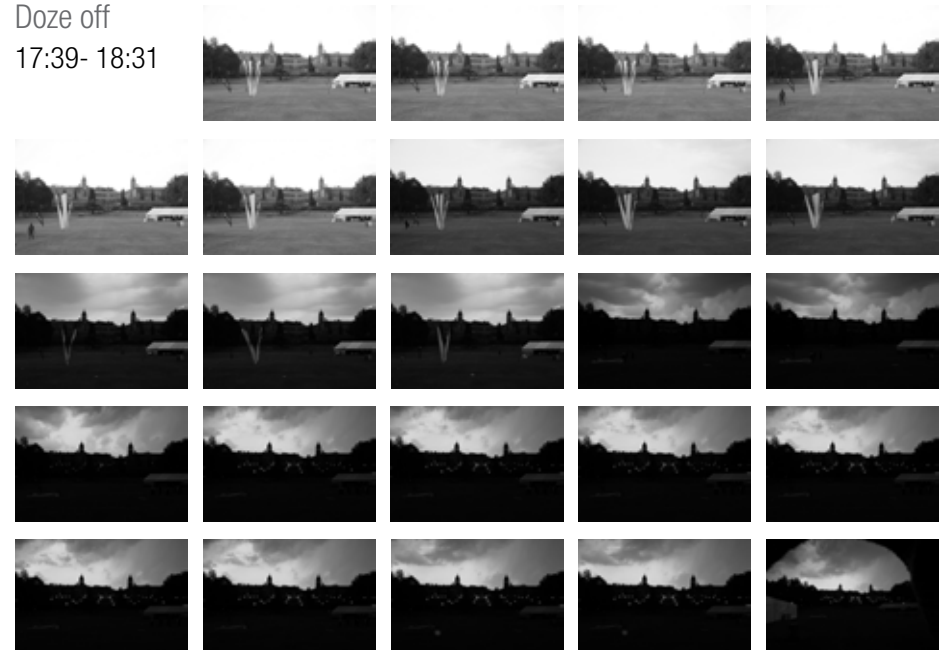
Fig. 2.7  
Church Street surface study

The second scale of the working landscape focuses on the site of the Union Buildings itself. An investigation was conducted as to how the buildings awoke and dozed off. The study made use of time lapse film as medium to record these two periods. The study created a greater awareness of the many role players engaging with the site at the two periods recorded. The events in both periods could be classified by their frequency of occurrence (i.e. whether they happened everyday, every week or once off).

Awakening  
5:23- 07:00



Doze off  
17:39- 18:31



**Fig. 2.8**  
*Video stills of Awakening and Doze off*



## Site Analysis

As explained earlier the site was used as a shale quarry in the 1890's to cater for the extension to the east of Pretoria. The Union Buildings were placed on site in such a way that the eastern and western blocks required minimal excavation and filling. The amphitheater was where the most filling happened because it was in the middle of the ravine. This has become problematic because of the water channels on the northern side of the buildings that are overgrown and under maintained. This causes the ground water to accumulate beneath the amphitheater as can be seen in the hydrology diagram in Fig. 2.9.

In Sir Herbert Baker's words: "Below the main buildings there would be abundant space on either side for future subsidiary buildings down to Church Street with an open park between" (Sir Herbert Baker, 1909). Regarding the future issue of land Sir Herbert Baker advised Public Works to purchase the land on the southern side of Church Street opposite where the axis of the buildings crosses Church Street (Sir Herbert Baker, 1909). Despite the attempt of the architect to ensure the urban-future of the buildings, the buildings now find themselves in an ill-responsive urban fabric.

A new intervention between Church Street and the Union Buildings could create a better urban connection with the buildings and also re-establish its public relations. Gordon Leith, who was one of Sir Herbert Baker's 'young men' stated the following in the Johannesburg Star in 1928: "In my opinion there is plenty of scope for extension on the lower terraces. Something could be done there which would in a sense contribute to the general effect. I think new buildings could be worked into the general scheme without destroying the vista up to the main building" (Leith, 1928).

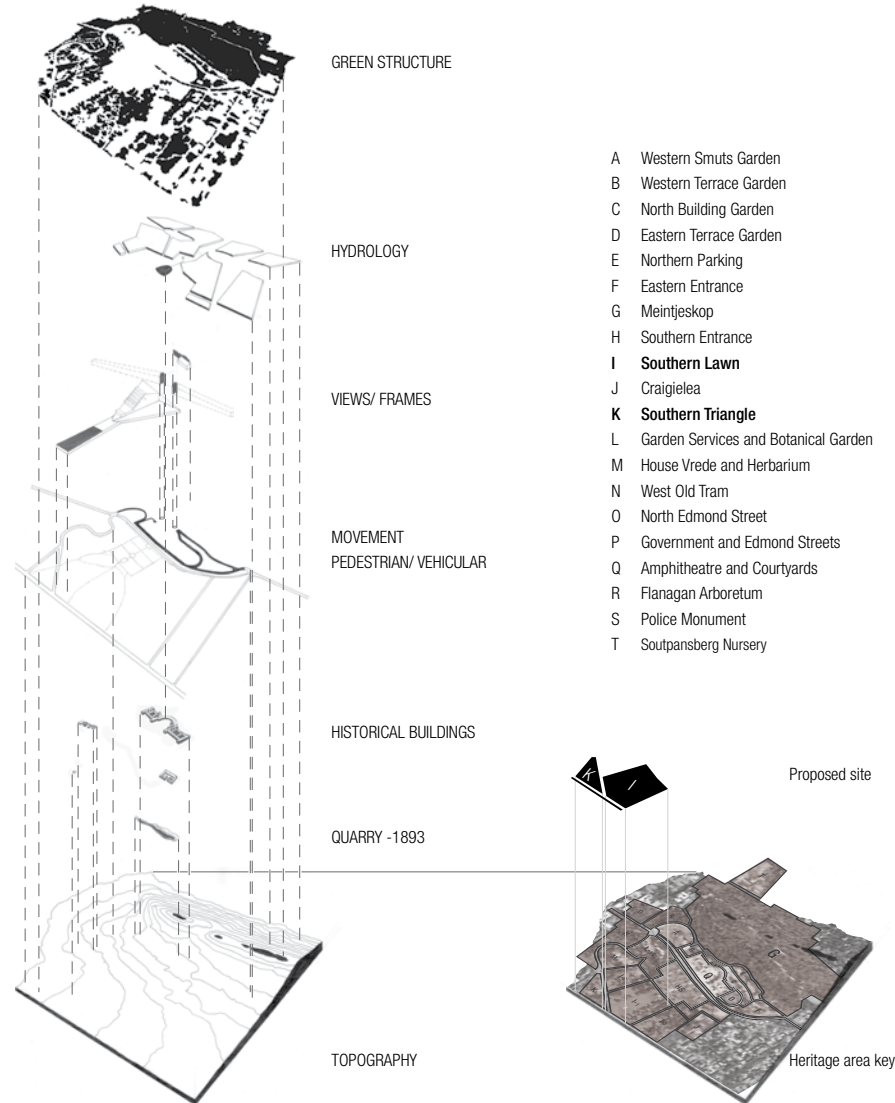


Fig. 2.9 Site Analysis Explosion Diagram



Fig. 2.10 Locality Plan

The following sketches were made on site and focused around the western edge of the building complex. This method of making quick vignettes was preferred to the conventional method of photography, to allow a more direct recording. These sketches helped in creating a deeper awareness of the sensitivity of the landscape.

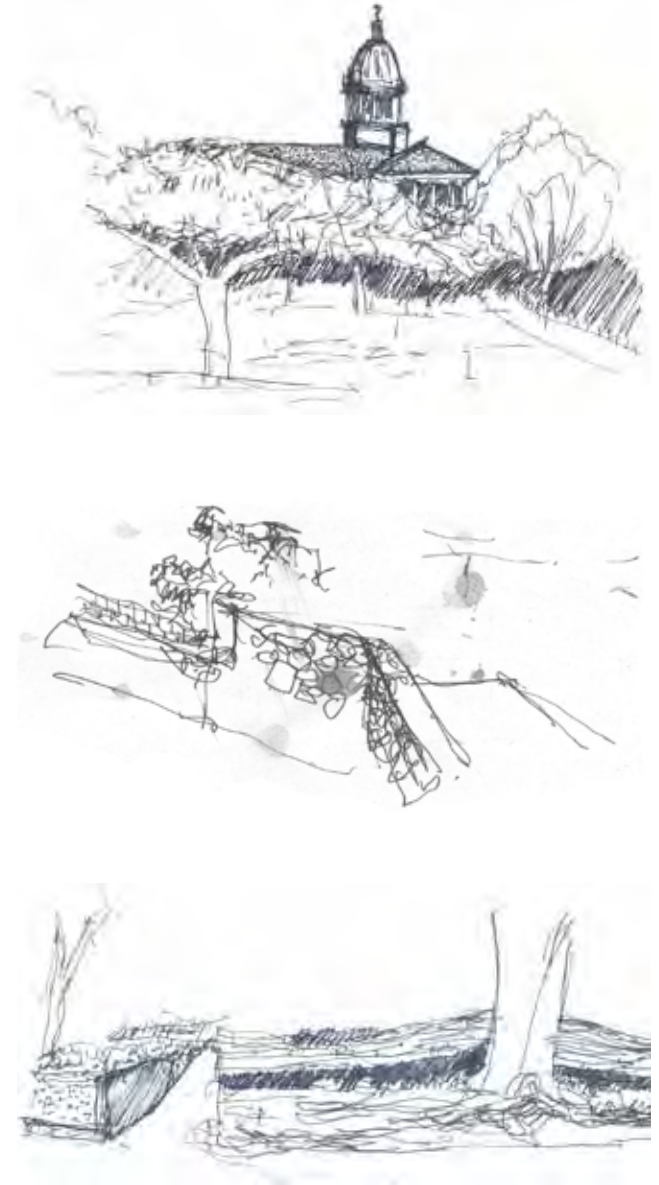


Fig. 2.11 Site Sketches



## INTERVENTION /03

### Introduction

The focus of the intervention is to reintroduce the Union Buildings to Pretoria. Pretoria in this sense has a dual meaning: Firstly it refers to the urban city fabric; and secondly it refers to the public. This reintroduction will take place within the centenary year of the buildings. The aim will be to re-establish the buildings' due public-prominence within the capital city and South Africa.

### The Site

The criteria leading to the selection of the site for the proposed intervention was both of historical and urban nature.

Sir Herbert Baker's idea of designing an 'Acropolis for South Africa' speaks of a monumental architecture found on the periphery of the city. The architect however was not naive to the fact that the city would grow. Sir Herbert Baker warned the Department of Public Works that the buildings would in future become very close to the centre of Pretoria (Sir Herbert Baker, 1909).

The idea is to stitch the site of the Union Buildings together with the city to form a better defined threshold between the two. Thus the selected site had to be on an edge between the city and the buildings. The Church Street (Stanza Bopape Street) edge of the site was identified as a non-responsive threshold to the buildings and was therefore chosen as the site for the intervention.

The site also sits between the park and the forest in terms of the building complex. This allows a new axis, one which escalates from a general impression to a personal discovery.

The selection of this threshold site allows the proposed architecture to explore spatial possibilities between the everyday of the city and the more sacred historical layer of the Union Buildings (see Fig. 3.1).

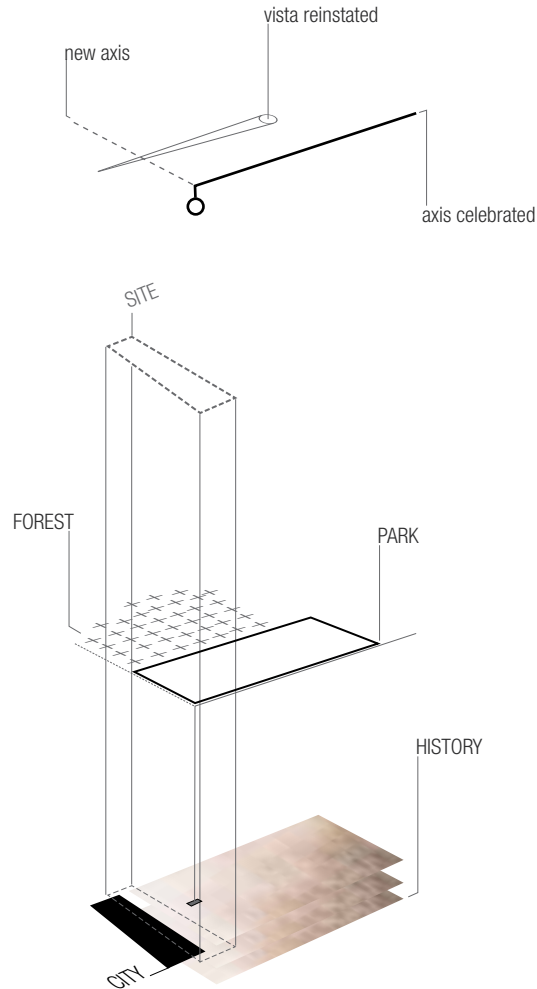


Fig. 3.1 Site concept diagram

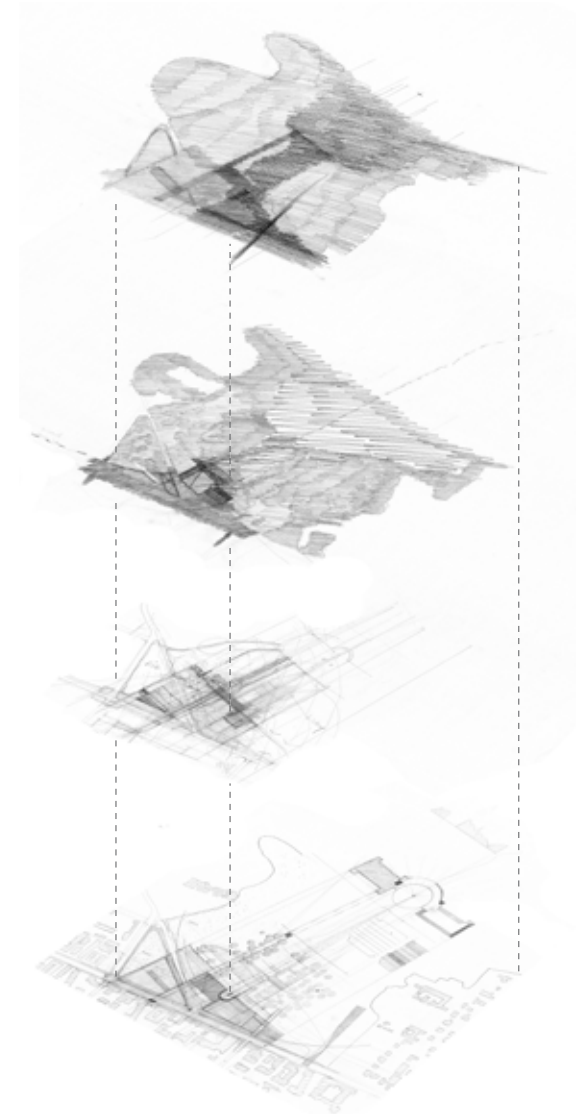


Fig. 3.2 Site development diagram

## Aims and Objectives

The new intervention will react on different scales to achieve the overall objective: The reintroduction of the Union Buildings to the city of Pretoria. The aim of each scale is discussed below.

### Urban scale /

To stitch the Union buildings together with the non-responsive surrounding city fabric, thus becoming the threshold between the city and the buildings.

### Landscape scale /

Allowing the user to discover the building complex on a personal level, thus becoming the threshold between the park and the forest.

### Spatial scale /

Investigating an architecture which celebrates and commemorates history but which also belongs to the zeitgeist of the present.

### Detail scale /

On a material level the dissertation aims at exposing the memory of time, thereby creating a stronger awareness of the dimension of time in architecture.

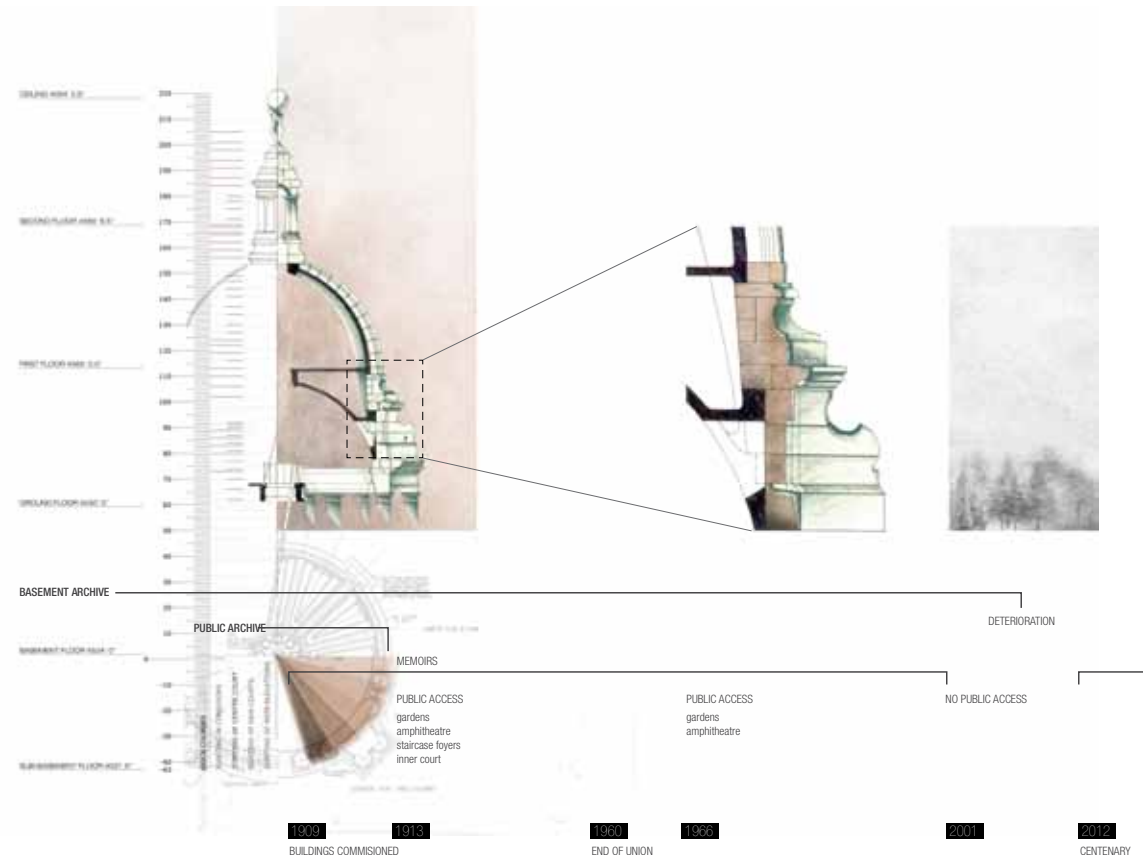


Fig. 3.3 Time-concept diagram

## The Programme

### Interpretative Archive

Although the architecture of the Union Buildings is of static and stereotomic nature, the symbolic value of the buildings has changed greatly throughout their existence. The new intervention will attempt to represent these different eras in history, allowing the user to achieve a greater understanding of and appreciation for the buildings.

The different time lines have been divided into five eras:

<b>Birth</b>	1909-1912
<b>Union</b>	1913-1960
<b>Oppression</b>	1961-1993
<b>Democracy</b>	1994-2000
<b>Power</b>	2001-2012

These time lines are captured in two separate spaces; a basement gallery of one hundred Sir Herbert Baker drawings from 1909-1912 and a second gallery focused around the events from 1913 to 2012.

The new intervention also consists of a memorial located at the General Louis Botha statue which was erected in 1946. The proposed memorial is focused around the idea of weathering and the impermanence of architecture. This space consists of a corridor which submerges into the landscape and exhibits the different types of stone used in the Union Buildings. The blocks of stone are left to deteriorate in order to acknowledge the effect of time on architecture and matter.

PROGRAMME



1909 1910

1913

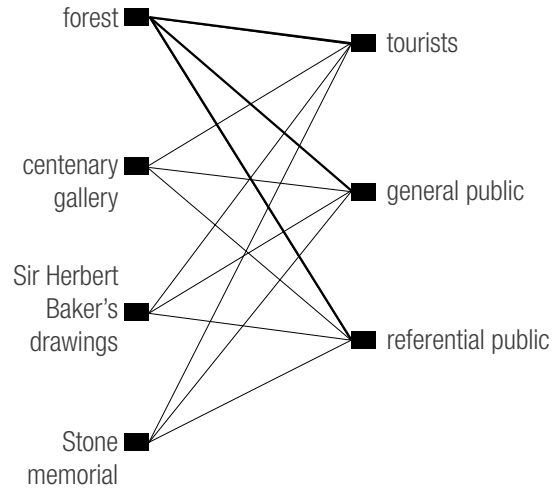
1960

SYMBOL OF  
PUBLIC ACCESS

**BIRTH**

**UNION**

-gardens  
-amphitheatre  
-staircase foyer  
-inner court



ROLE PLAYERS

1994

2001

2013

**OPPRESSION**

- gardens
- amphitheatre
- staircase foyer

**DEMOCRACY**

- gardens
- amphitheatre

**POWER**

- gardens

- gardens
- new intervention

Fig. 3.4 Programme diagram



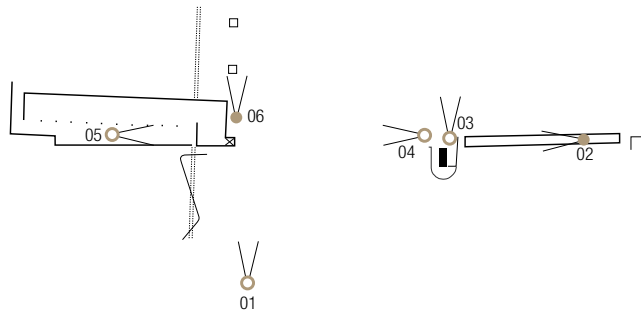
## The Discovery

The new intervention allows users different levels of participation. The idea is not to force the user from point 'A' to 'B', but to rather guide the user. This is achieved through the programme in relation to the articulation of materials in order to guide or seduce rather than direct the user.

The scheme's aim is not to try and compete with the Union Buildings in terms of prominence, but to cohere and introduce the buildings and their landscape.

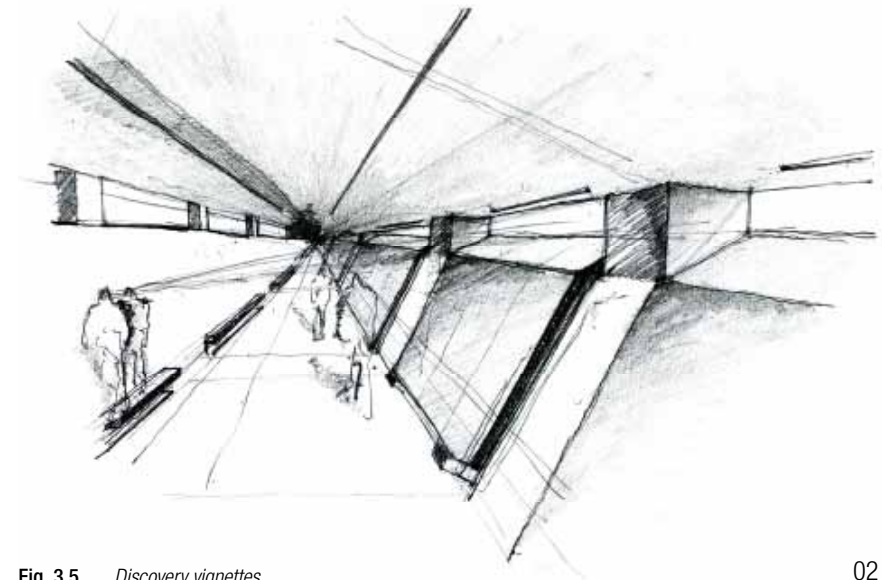


01



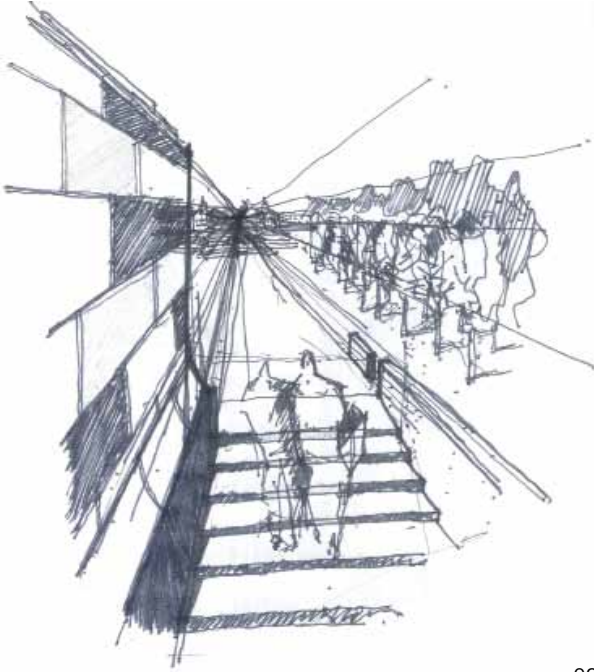
### Key plan

- exterior view
- interior view

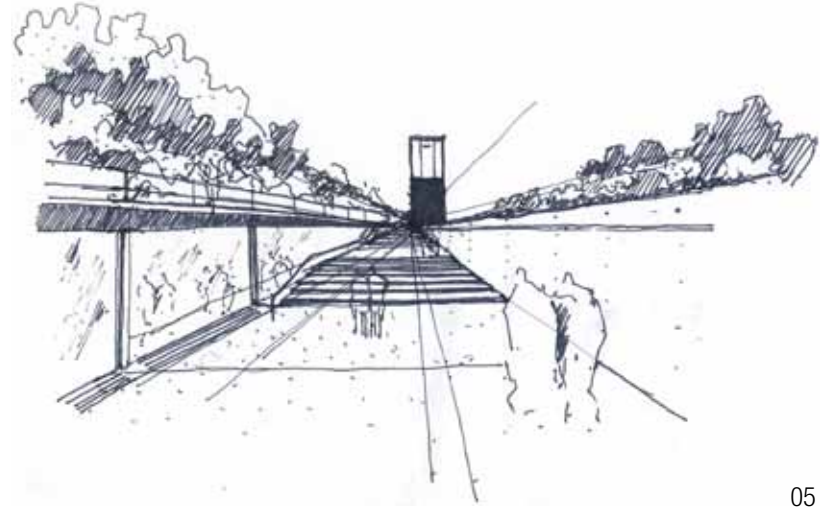


02

Fig. 3.5 Discovery vignettes



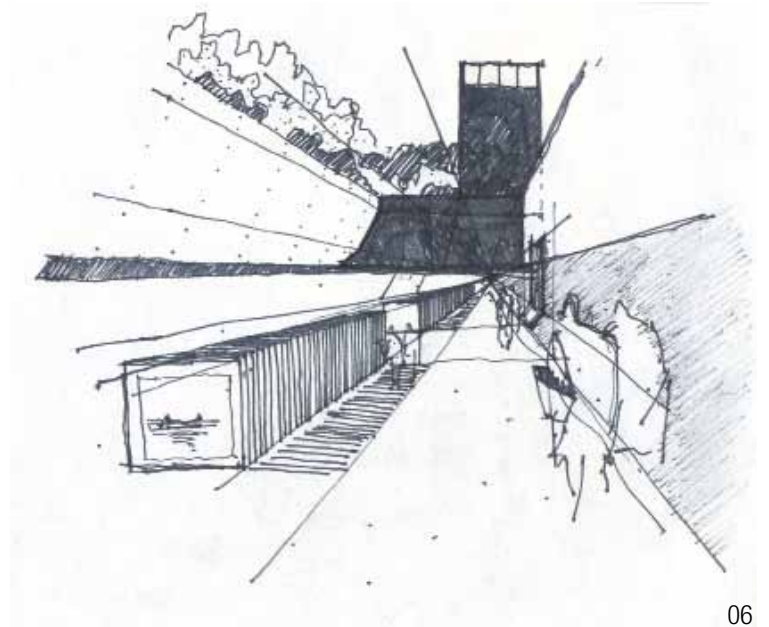
03



05



04



06

## PRECEDENT STUDIES /04

### Introduction

The objective of this chapter is to investigate and study mind sets toward the celebration and commemoration of certain periods or buildings through architectural intervention. The idea was to interpret and translate the thinking behind the precedents rather than to adopt specific design methodologies or typologies. In that sense it becomes part of the development of a normative position and philosophy on the making of an architecture that commemorates.

### The work of Carlo Scarpa

#### Attitude toward history

Carlo Scarpa was introduced to the phenomenon of memory and simultaneity at an early age. He was born in Venice in 1906 after which his family moved to Vicenza after his second birthday (Famous architects, 2012). After his mother's death in 1919 his family moved back to Venice. His ability as an architect to work within environments of different events and layers of time in the author's opinion relates to his childhood years.

Scarpa's architecture is one that is in harmony with tradition and history but at the same time introduces something of the present, a new layer. He simultaneously absorbed the existing memory and celebrated the new. His choice of materials was also in harmony with the existing layer and these materials was of haptic nature, containing its own kinetic narrative. Juhani Pallasmaa speaks of these haptic materials as devices which augment the temporal quality of a project.

Materials and surfaces have a language of their own... Stone speaks of its distant geological origins... wood speaks of its two existences and time scales; its first life as a growing tree and the second as a human artefact made by the caring hand of a carpenter... brick makes one think of earth and fire, gravity and the ageless traditions of construction (Pallasmaa, 2000:76).

"Instead of confronting history antagonistically, he developed an additive design method that overlaid existing architectural strata with an abstract design language" (Murphy, 1990:4). "Scarpa approached neither the site nor the drawing with a 'clean-slate' mentality, as seen with other Modern architects. The reveal and the joint became the means of both linking physical fragments and seaming together the different narratives" (Field, 2009:78). Scarpa never finished his formal training as an architect and started his career as an interior and industrial designer. This is probably why his approach to architecture was one of such intimate nature, as he was comfortable with materials and the connections between them (Famous architects, 2012).

Scarpa's work is one that submits to the zeitgeist of a place and its execution belongs somewhere between preservation and elimination. His architecture does not belong to the past nor does it reject the past, it is rather embedded in the past and at the same time speaks of a new layer. His architecture reveals and celebrates the fourth dimension, time.

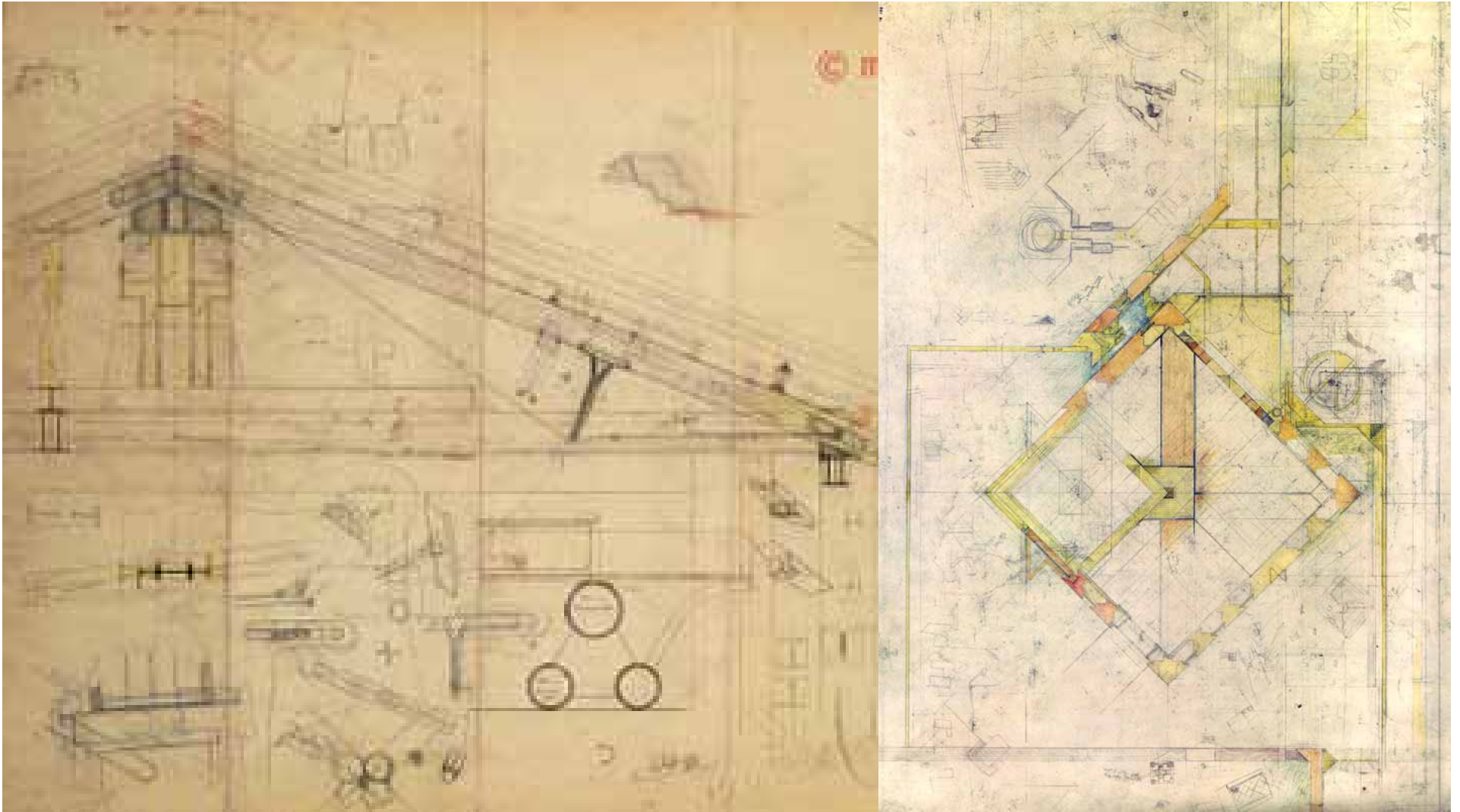
#### The drawing

The idea of drawing in architecture has changed since the classical times. The drawing was originally used as a submissive tool to create architecture. Today the drawing has become an entity on its own. This is even more evident in student architecture where the drawing plays an important role, serving as the final medium. This has had a negative effect on how architecture is conceived on an academic level because the drawing has the ability to be subjective.

I want to see things. I don't trust anything else. I place things in front of me on the paper so that I can see them. I want to see therefore I draw. I can see an image only if I draw it (Murphy, 1990:12).

In the work of Carlo Scarpa the drawing was always submissive to the properties of materials. The drawing was not regarded as an artefact on its own, it was merely a representation of the real.

Scarpa drew to build. Even the most superficial inspection of his drawings reveals an obsession, right from the start of an idea, with materials, the construction, the effects of light, textures, fixings and the three-dimensional assembly of objects (Murphy, 1990:12).



## The models of Peter Zumthor

### The model as design tool

Zumthor, uses the model not only as a tool for representation, but the model becomes central to the design process (Zumthor.tumblr, 2012). The model directly investigates three dimensional possibility where as the drawing is a further extension.

In this dissertation the model was used on different scales and for many purposes. Different materials were used to allow for exploration both in search of representation and replication of ideas.



Fig. 4.2 *Models by Zumthor*

## The Christmas cards of Thomas Heatherwick

### Tangible artefacts

Since 1994, The studio of Thomas Heatherwick has made their own Christmas cards for clients and collaborators (Dezeen, 2006).

Within the global internet culture of today, the idea of a tangible letter or card may seem obscure, but it's exactly within this context that it is even more appreciated. Similarly, this dissertation also aims at bringing people closer to the real on a phenomenological level.

The British High Commissioner, Lord Selborne, spoke of the Union Buildings: "The people who chose the site have chosen one of the finest sites in the world, and that people from all over the world will come to wonder at its beauty" (Botha, 1989:1).

While focusing on celebrating the centenary of the Union Buildings on a metropolitan scale, readings of the original intentions on an international scale have led to the idea of broadening the image of the buildings by sending postcards from the site.

These postcards will not be mere photographs of the buildings but will aim at conveying the tangible qualities of the site and the layering of history. The cards will be based on the notion of the embossings of Church Street illustrated in Fig. 2.7 on page 24. This idea again has to do with the recording of surface and memory.

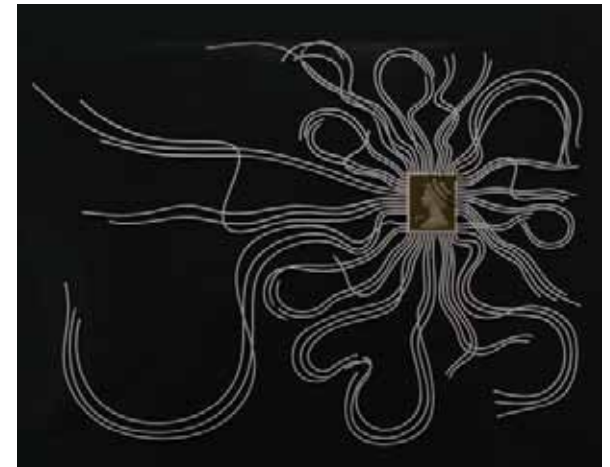
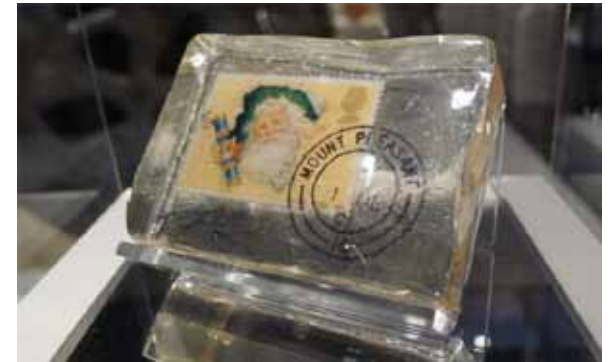
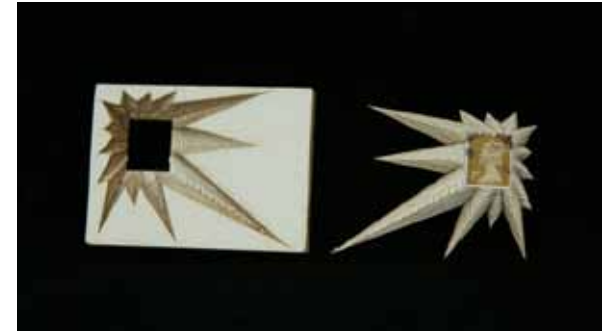


Fig. 4.3 Thomas Heatherwick's *Christmas cards*

## Rachel Whiteread

### Negative space and the anti-monument

Artist Rachel Whiteread works with the ordinary. Her work is concerned with making the ordinary visible in new ways. She works with negative space: beneath furniture, under staircases, within containers.

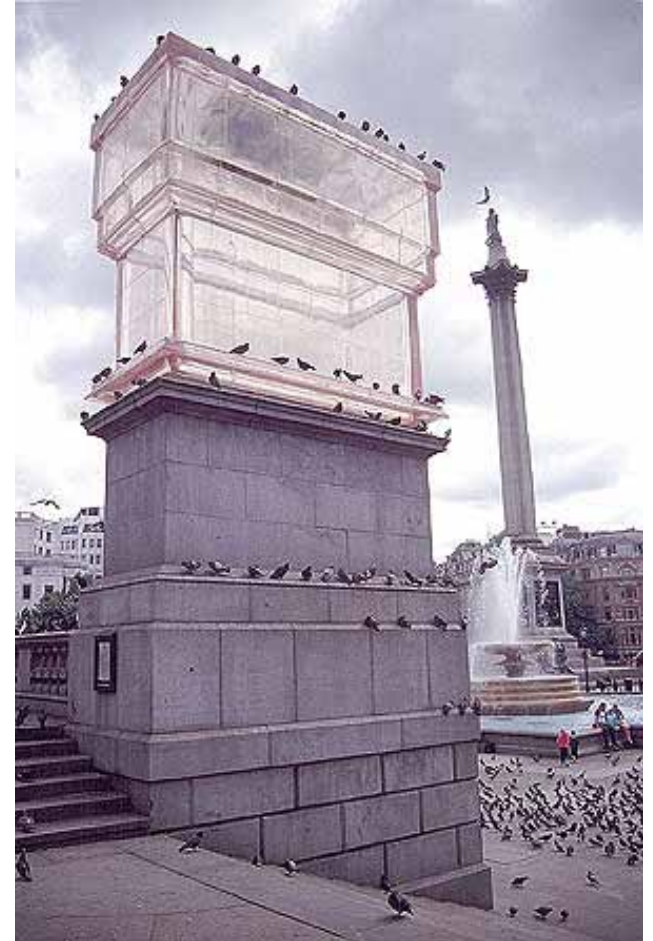
The changing symbolic value of the buildings was seen as the negative space that had to be made visible. The fact that public access has been denied to the buildings also strengthens this argument. The stereotomic nature of Whiteread's work has had an influence on the materiality and construction of the new intervention. Whiteread's anti-monuments are shown in Fig. 4.4 to 4.6.



Fig. 4.4 House, East London, 1993



**Fig. 4.5** Water Tower,  
*Soho, New York, 1998*



**Fig. 4.6** *Untitled Monument,*  
*Trafalgar Square, London, 2001*



## Mémorial des Martyrs de la déportation

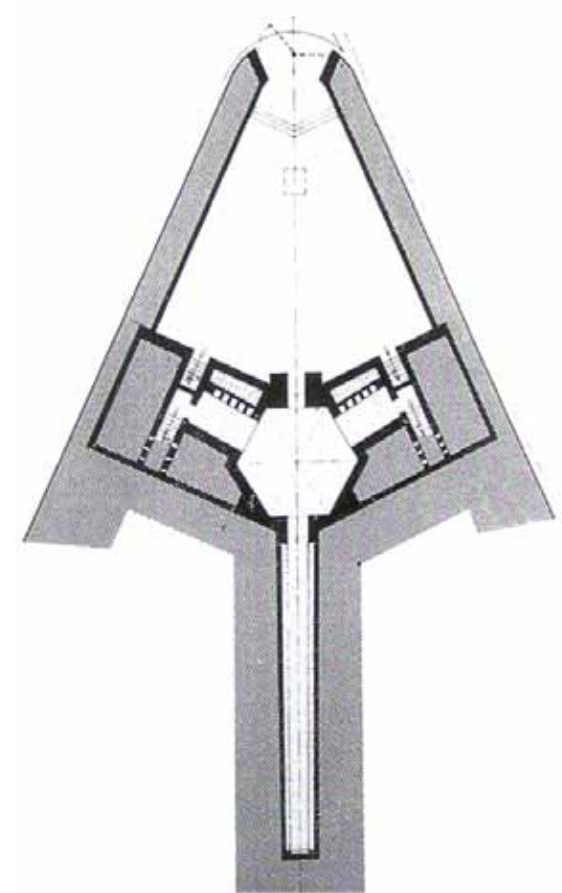
<b>Location</b>	Isle de la Cite, Paris, France
<b>Completion</b>	1962
<b>Architect</b>	Georges - Henri Pingusson

### Discovering the hidden

The memorial was built to commemorate the transportation of Jews from Paris to Germany during the Holocaust.

The memorial is located behind the renowned Notre Dame Cathedral in Paris. Despite its primary location it is not well known. The building is hidden at the end of the island and the entrance is understated. This creates a position that visitors have to make decisions when entering the building.

In the same way the new intervention located in front of the Union Buildings should not compete with the existing architecture, but allow for a new investigation, a discovery, a deeper understanding.





05 | Design Development

06 | Technical Resolution

07 | Conclusion

# EXPLORATION /

## DESIGN DEVELOPMENT /05

### Exploring through Drawing

Designers almost always start with a drawing of some kind. In this medium the first introduction takes place, the designer is for the first time exposed to his or her own thoughts.

### Tekton drawings

The drawings in Fig. 5.1 are focused around the idea of construction or the 'tekton'. These drawings were made both on site and at the drawing board. The aim of this exercise is to create an awareness of the final resolution in which architecture exists as early as possible.

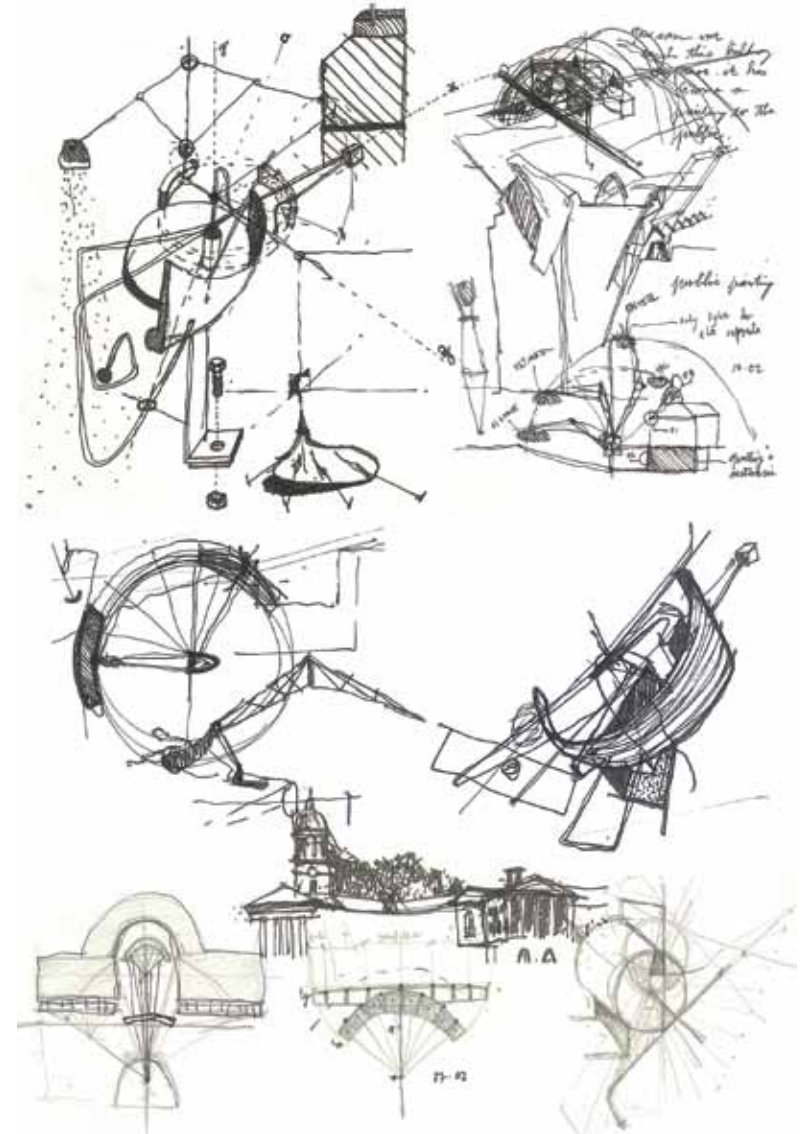


Fig. 5.1 Tekton exploration drawings

## Exploring through Material

Even though drawing can be seen as the first medium of exploration this is not, in the authors view, where the exploration should end. Architecture will, in its ultimate resolution, be constructed out of materials and space. Matter and space should be explored before final conclusions are made.

## Concept model

The concept of the scheme was explored from the earliest stages in the dimension of materials and representational models. The concept is focused around the idea of recording memory and then making this memory accessible and digestible.

The drawings in Fig. 5.2 were made to assist in building the concept model. The concept investigates the possibility of celebrating memory, physically and intangibly.

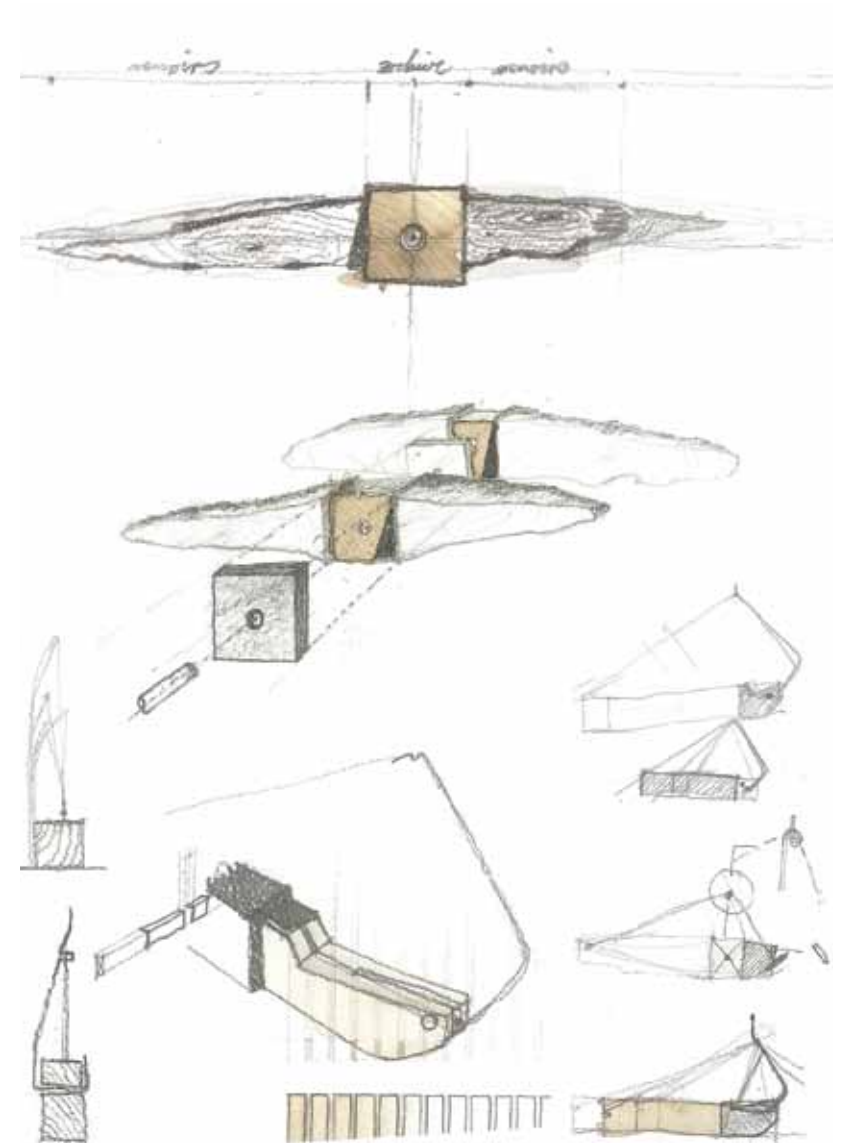


Fig. 5.2 Concept model drawings



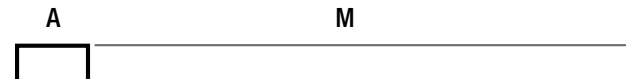
This model was constructed from fifty four-year old timber branding that was salvaged from a building site. The timber is embedded with memory that leads back to when the tree was still growing. This evidence testifies of the stripping of the material from the building.



The same pieces of timber were then planed to make them accessible to the hand and to represent the archive in which the memory is captured.

In the act of working with the material, the author immediately realised that the design explored on paper did not portray a true understanding of the material properties. The design was then altered as the process of construction continued. The form giving factors were not merely based on the scientific and pragmatic limitations of the materials under investigation, but the exploration also gave clues as to what the material wanted to become.

The exercise proved that exploring an idea in its final medium would lead to unforeseen and exciting possibilities, which would have been ignored otherwise.



**A I** memory archive

**M I** physical and intangible memory



**Fig. 5.3**  
*Concept model (February)*



**Fig. 5.4**  
*Painting of the Bank of England by Joseph Gandy, 1830*

### Recording lost surface

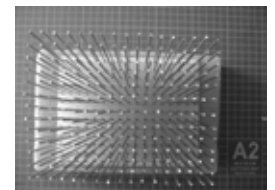
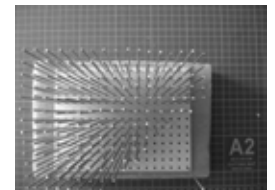
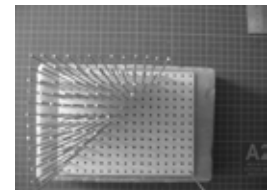
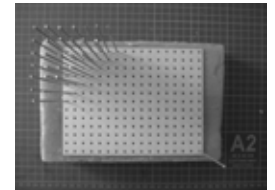
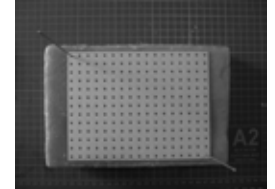
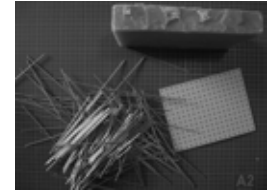
This painting of the Bank of England by Joseph Gandy was a representation of what the John Sloane building would have looked like if it was to reach the stage of ruination. The building never reached this stage as it was demolished to make way for a new building. Ironically, the man who instructed the demolition of the building was Sir Herbert Baker. Today the Union Buildings find itself heading towards a state which Sloane intended for the Bank of England.

The sandstone surfaces of the Union Buildings are in a state where nature has become the last craftsman. The buildings' surfaces are deteriorating as is the case with all sandstone buildings.

A surface recording device was constructed in order to take recordings of the sandstone weathered surface of the buildings. The process is shown in Fig. 5.5.



**Fig. 5.5**  
*Surface recording device*





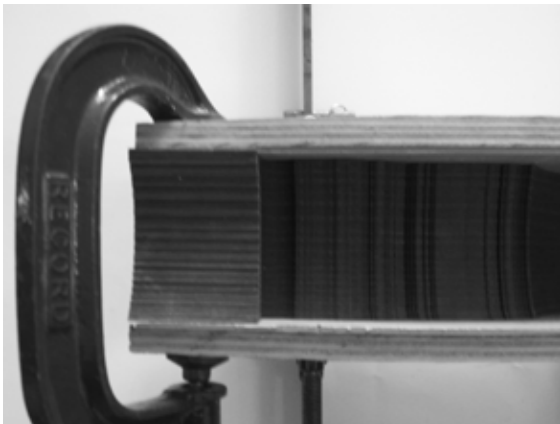
### Tower wax model

A detail model of the Union Building's tower was cast from wax to portray the vulnerability of the sandstone surface. Due to the nature of wax it is possible to imagine the surface deteriorating when handling the detail model.

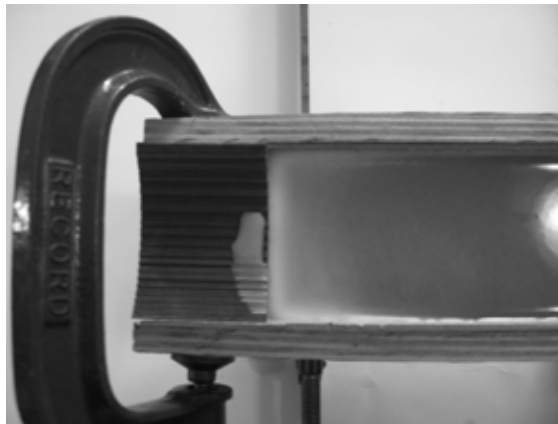


Fig. 5.6  
 Detail wax model

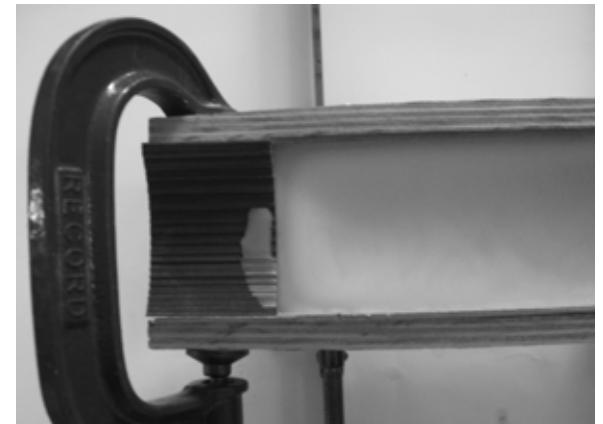
*void*



*liquid*



*solid*



### Exhibition stands for embossings

These stands were designed for the embossings taken in Church Street, shown in Fig. 2.7 on page 24. The idea was to allow the viewer to inspect the pieces without handling them. The height of the stands correspond to the height on which each recording was taken. The idea was that the pieces of paper would support themselves.

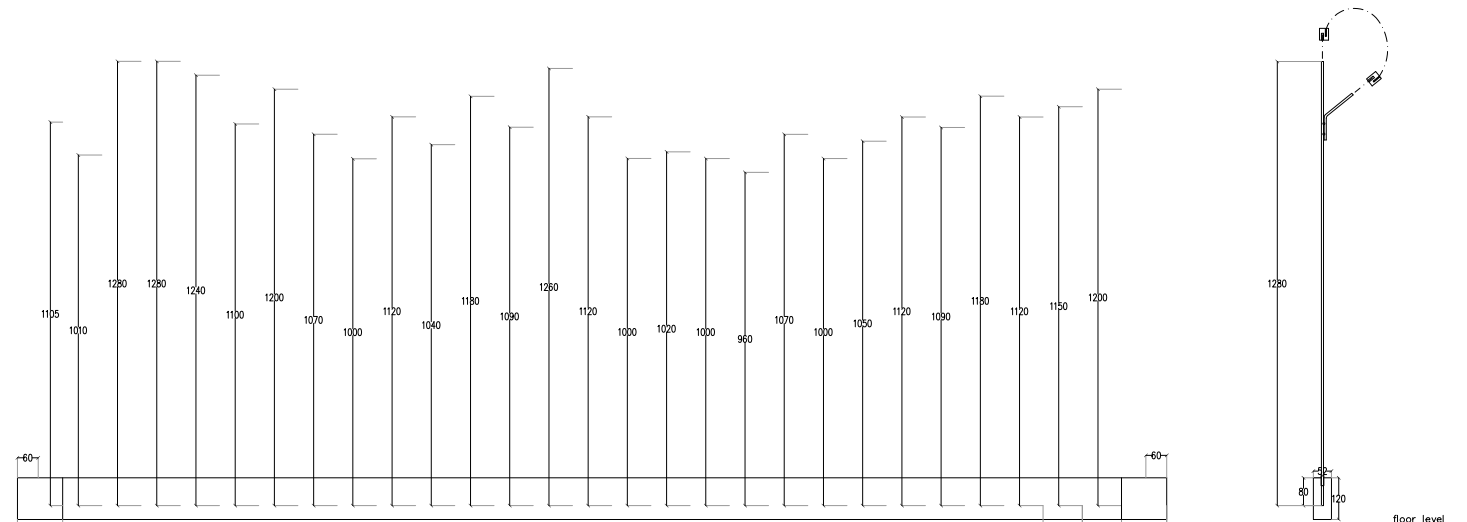
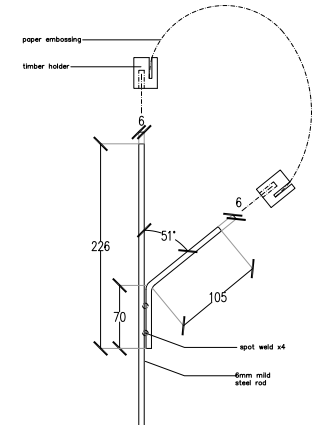
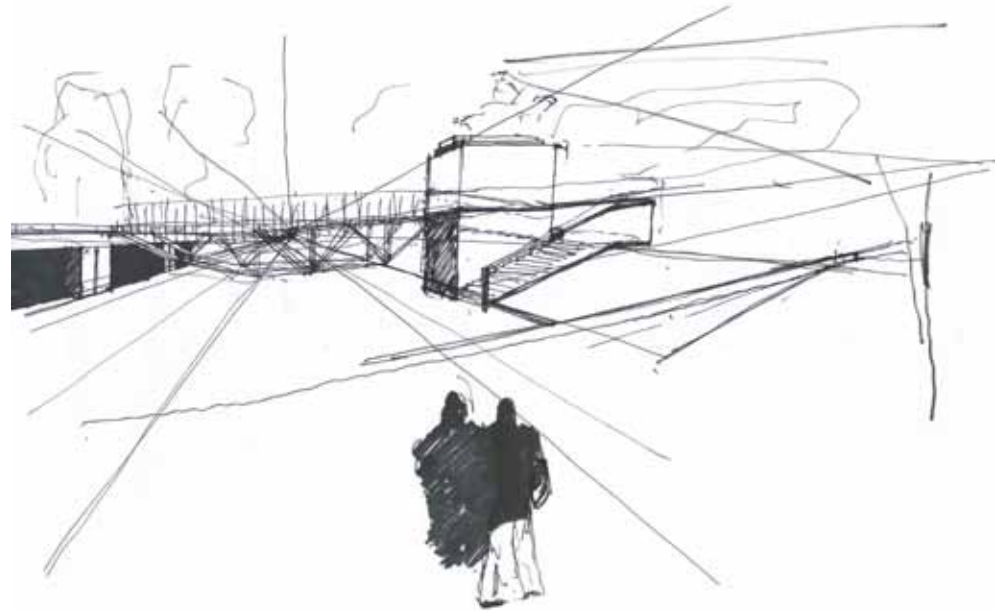
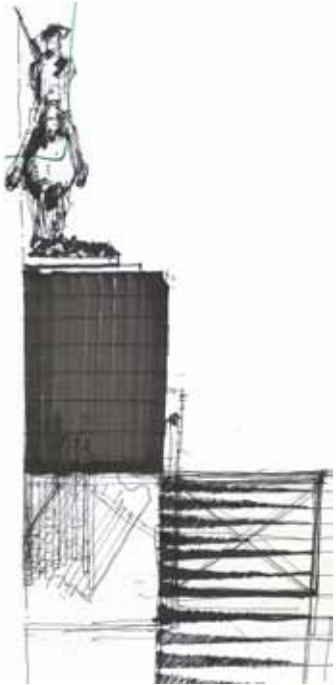


Fig. 5.7  
Embossing stands

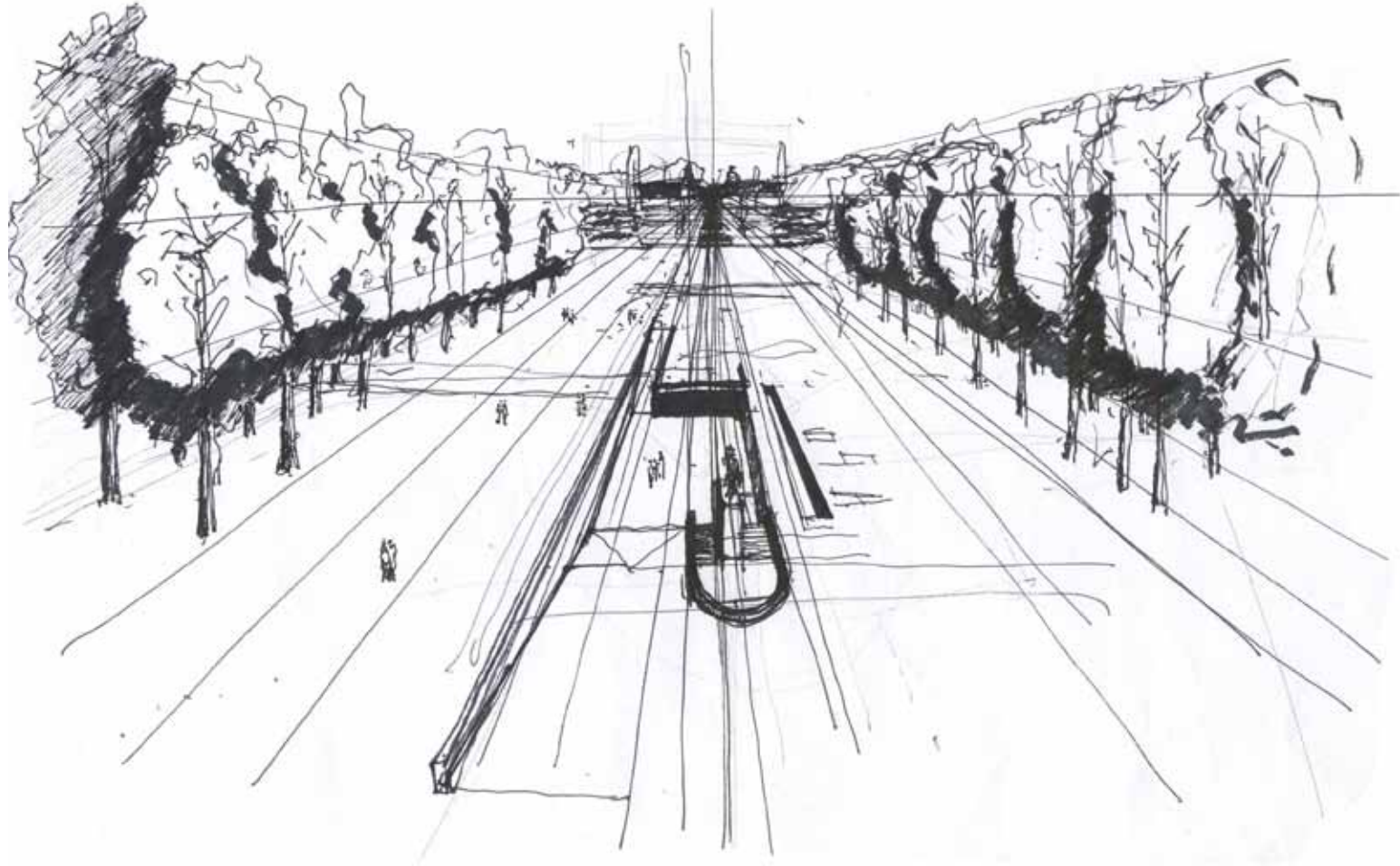
## Design Progression

### Preliminary drawings

These sketches were made in order to explore spatial possibilities on the selected site.



**Fig. 5.8**  
*Early conceptual work (March)*



## Urban intention

As discussed in chapter three, the idea was to create a better threshold between the city and the Union Buildings on an urban scale. Currently Church Street (Stanza Bopape Street) disperses to the east as it moves away from Church Square, thereby losing its human scale. By strengthening the threshold at the buildings the armature between the two points can be activated.

The connection towards the Art Museum should also be strengthened towards the south. This would create the possibility of connecting to Arcadia Street, which leads into the Hatfield precinct.

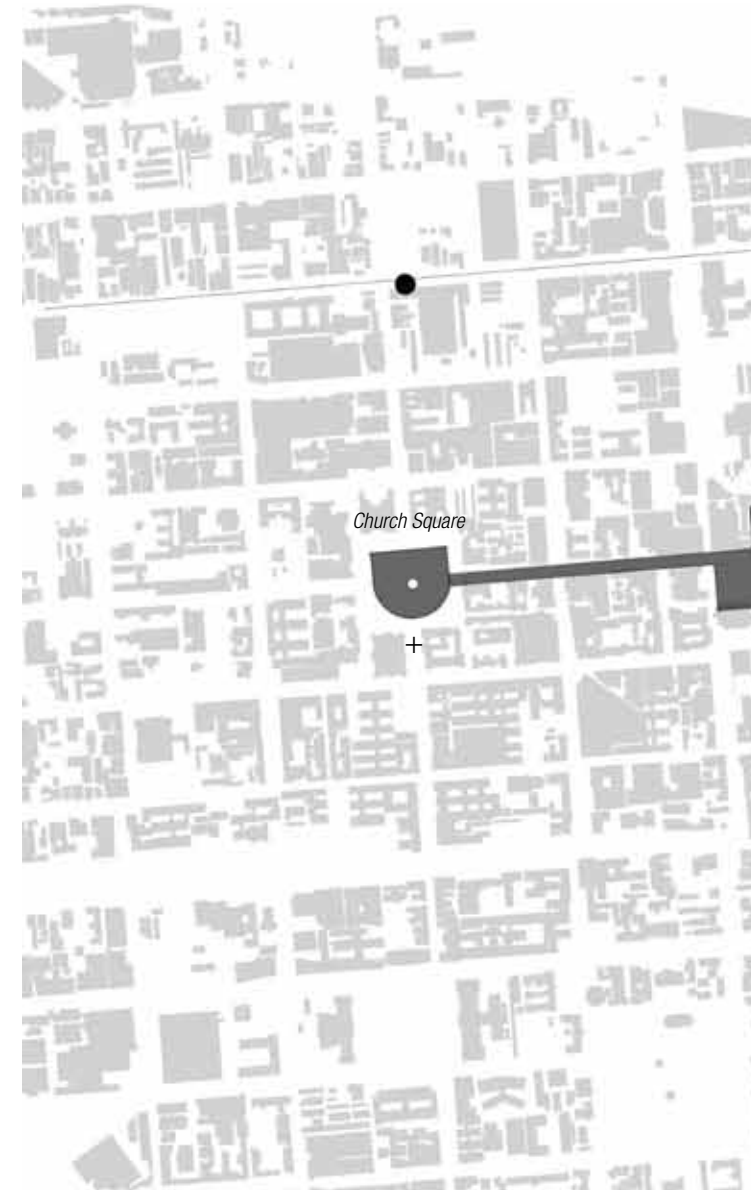


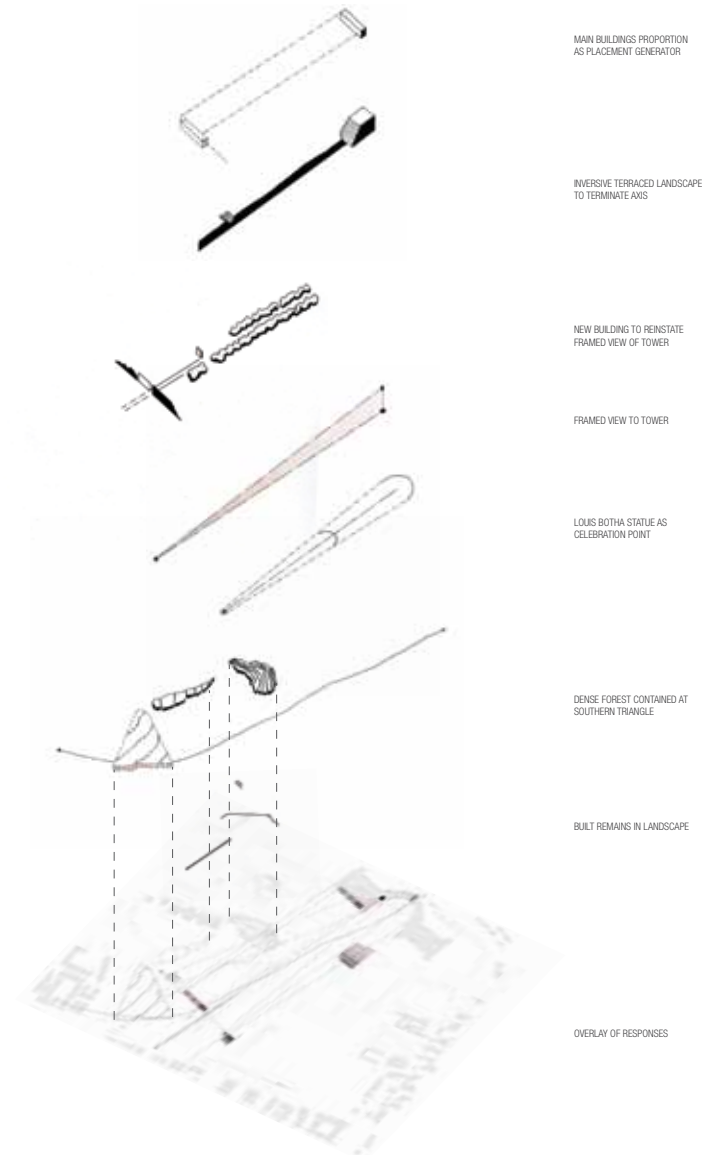


Fig. 5.9  
Urban intention diagram

## Site response

The general image of the Union Buildings is one that relates to ideas of the Renaissance namely: axis, symmetry, order, proportion and hierarchy. The first image one gets is standing in the park looking at the horizontal building on the kop, an image related to the romantic landscape.

The site however is full of hidden layers of time, and allows for exploration and discovery. The new intervention will aim at heightening these hidden layers to allow the user a deeper experience. The diagrams in Fig. 5.10 and 5.11 illustrate these hidden forces that gave rise to the form and route of the scheme. This will encourage users to investigate the landscape from new perspectives.



**Fig. 5.10**

*Site responsive explosion diagram*

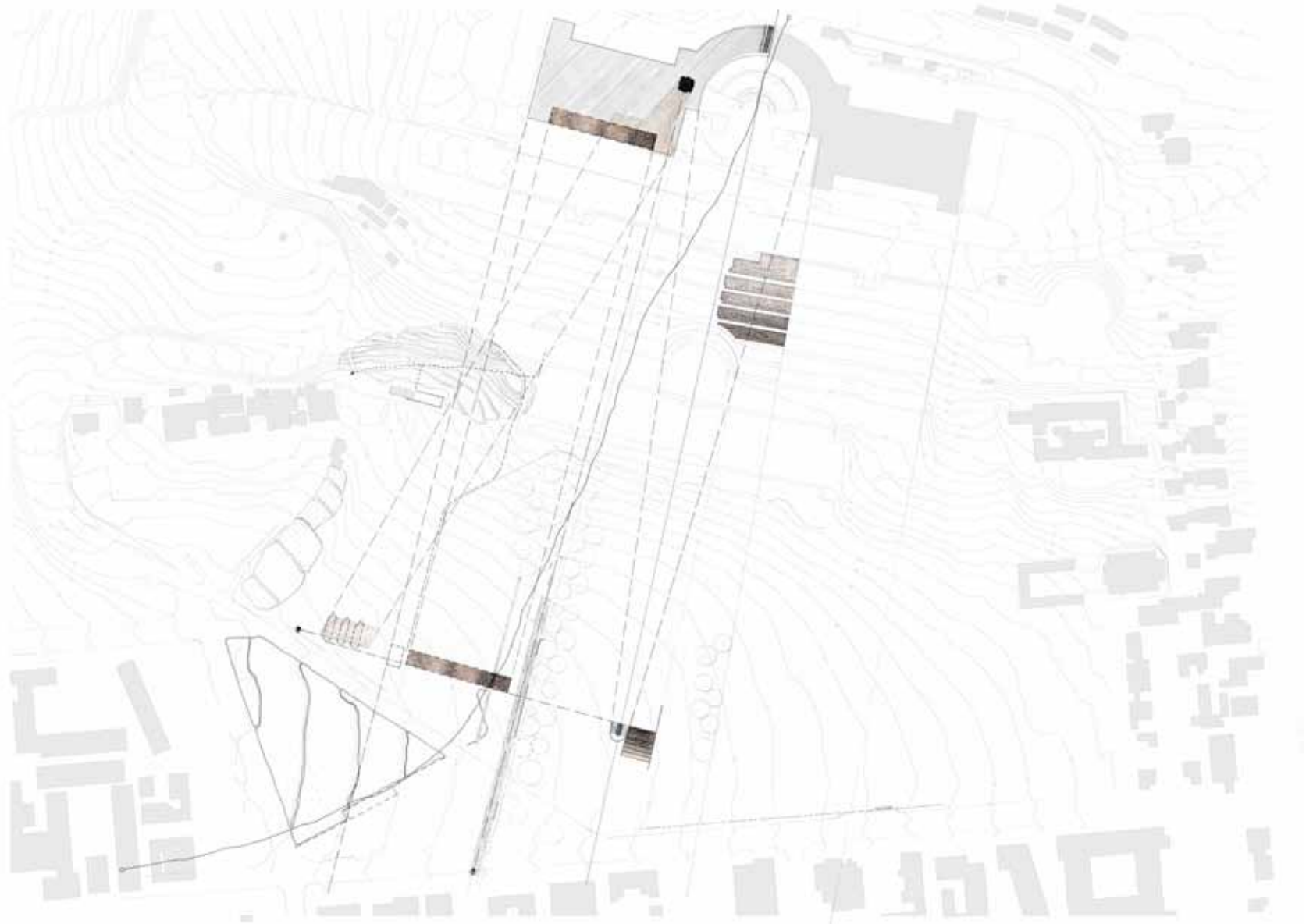


Fig. 5.11  
*Site responsive diagram*

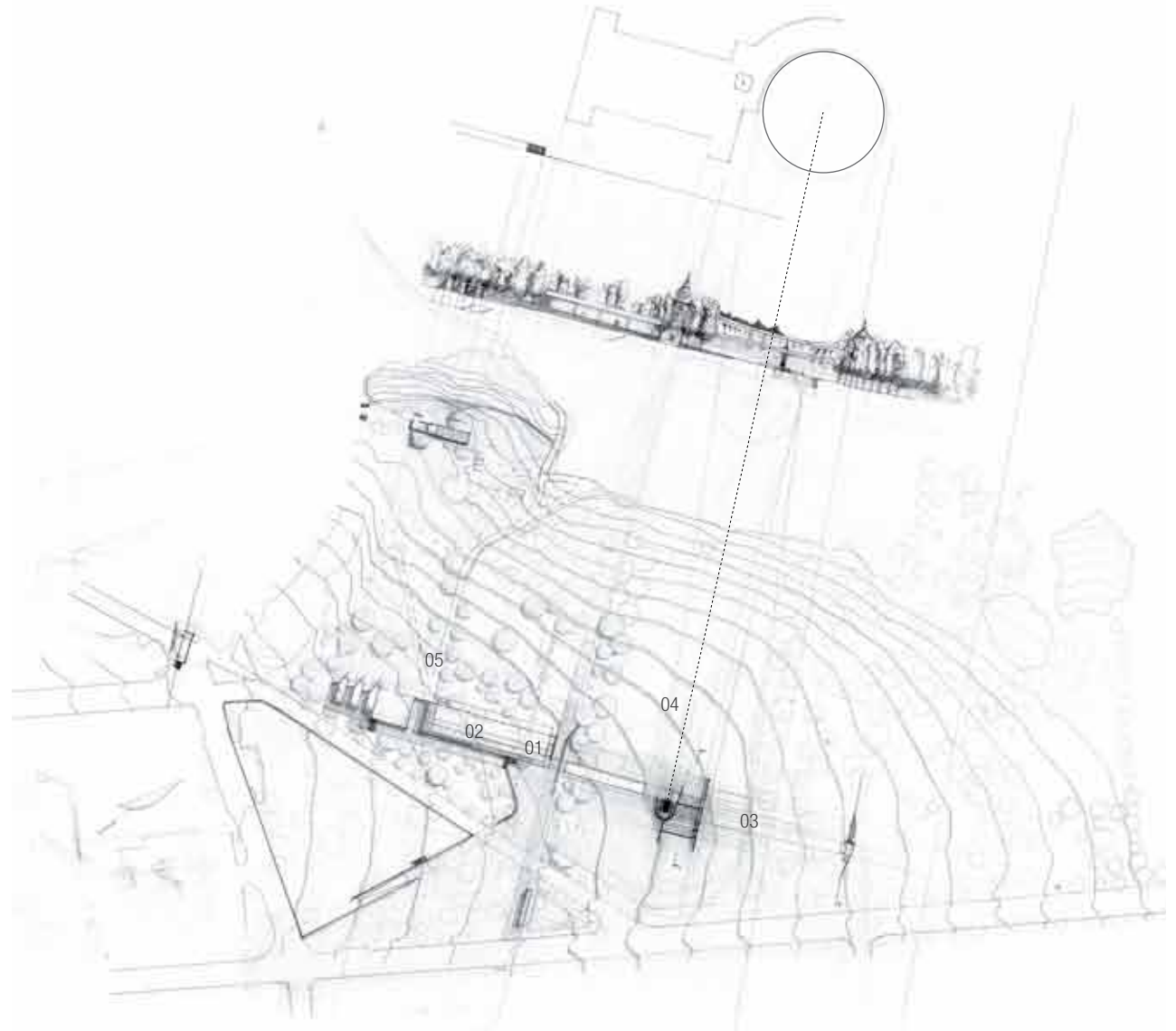


## Site plan development

The site plan developed from the hidden layers discussed in Fig. 5.10 on page 56. The statue of General Louis Botha was used as a nick point in the landscape from where the new intervention could be developed.

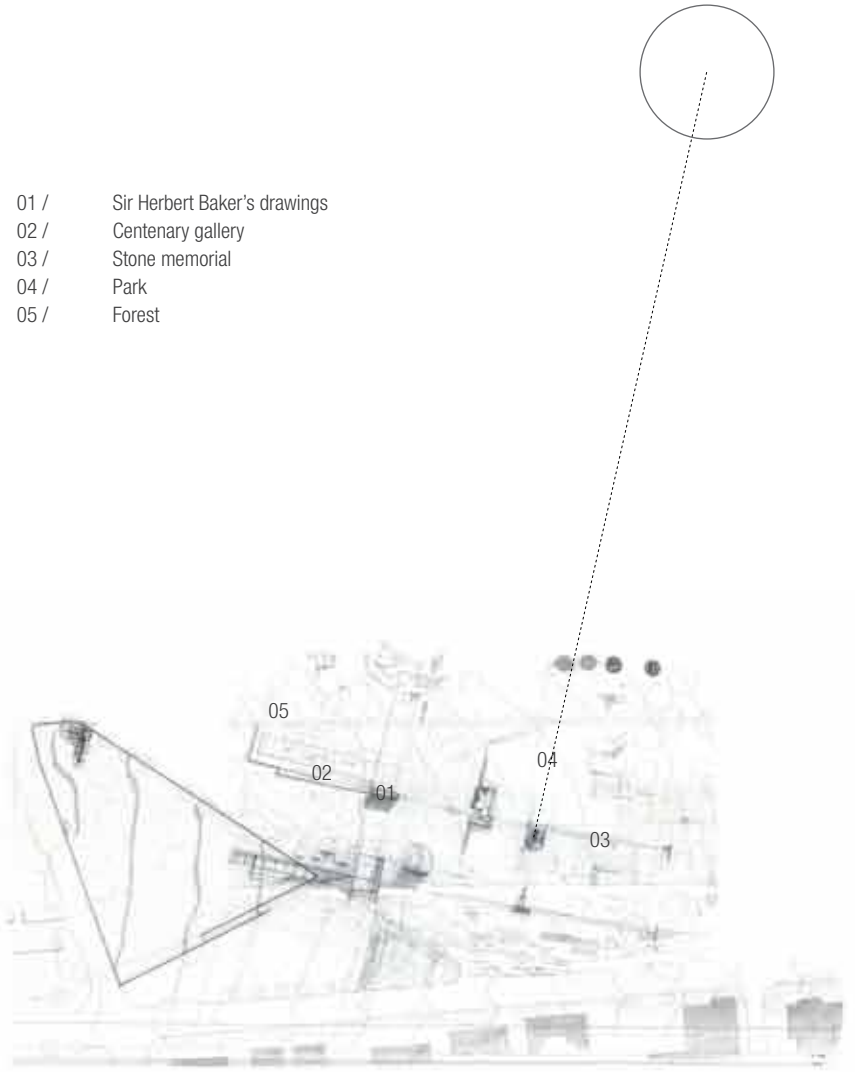
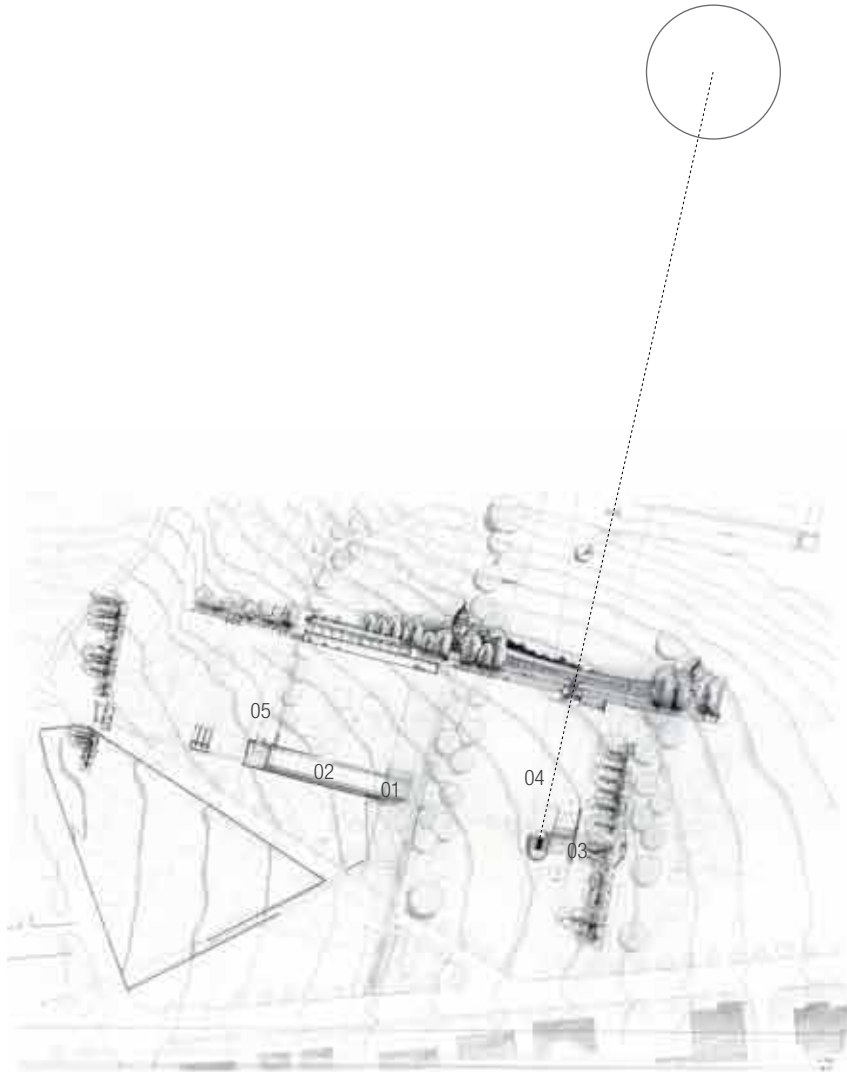
The existing north-south axis was celebrated by concluding it at the existing statue. A new axis was introduced from this celebrated point, which leads from the park into the new building and ultimately into the forest.

To ensure a non-obstructive horizon from the southern edge, it was decided to create the connection between the southern triangle and the site by making use of landscape architectural elements. The triangle is divided into two landscapes, the edge to the forest and the entrance to the site. The line dividing the two was determined by the historical ravine line. This space allows a user to be in the city while having a visual reference to the buildings.



**Fig. 5.12**

*Development of site plan (April)*



- 01 / Sir Herbert Baker's drawings
- 02 / Centenary gallery
- 03 / Stone memorial
- 04 / Park
- 05 / Forest

## Site plan development

A model of the site was built at 1:1000 to explain the relationship between the new intervention, the landscape and Church Street (Stanza Bopape Street).



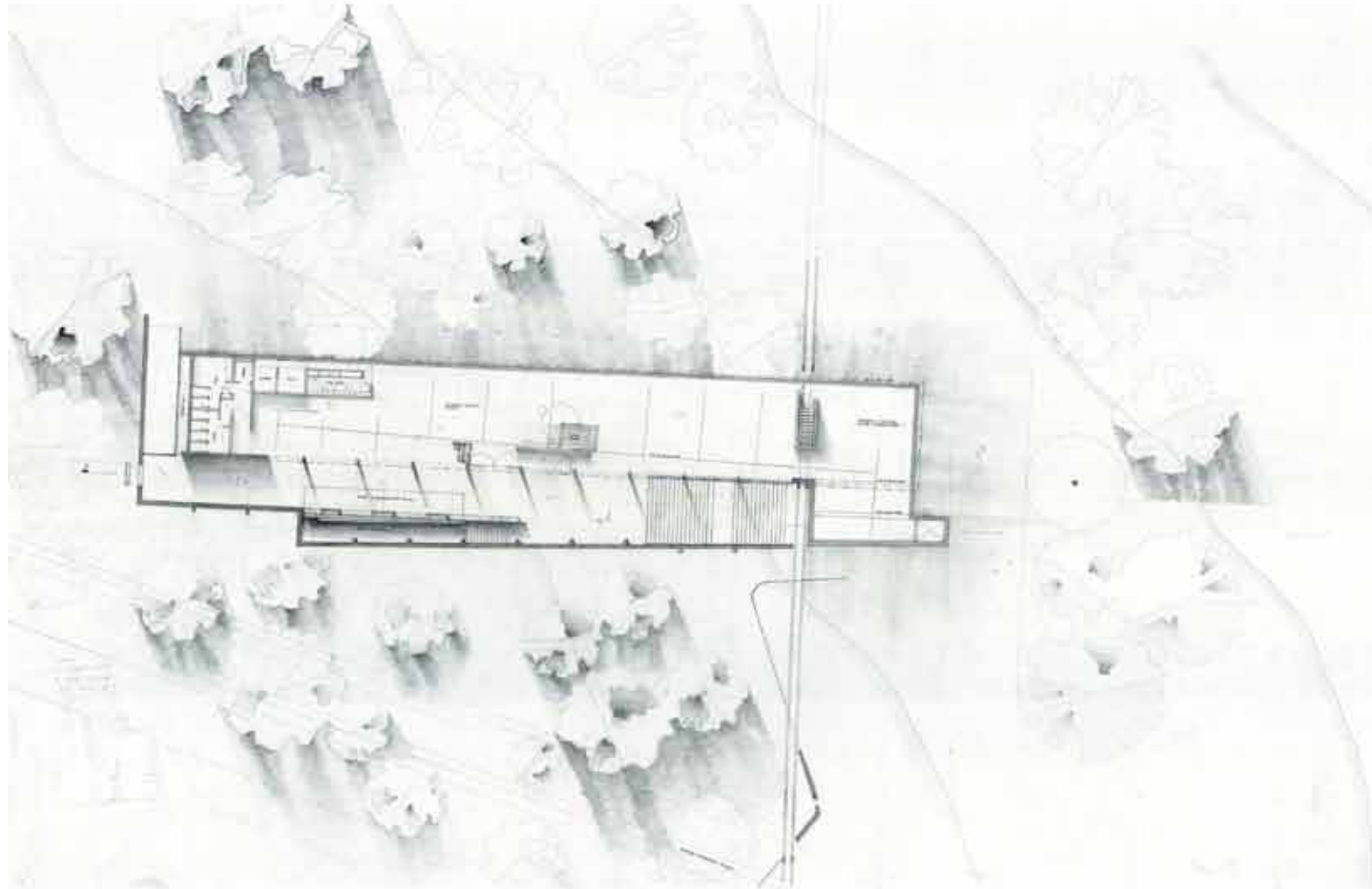
Fig. 5.13  
*Site model*

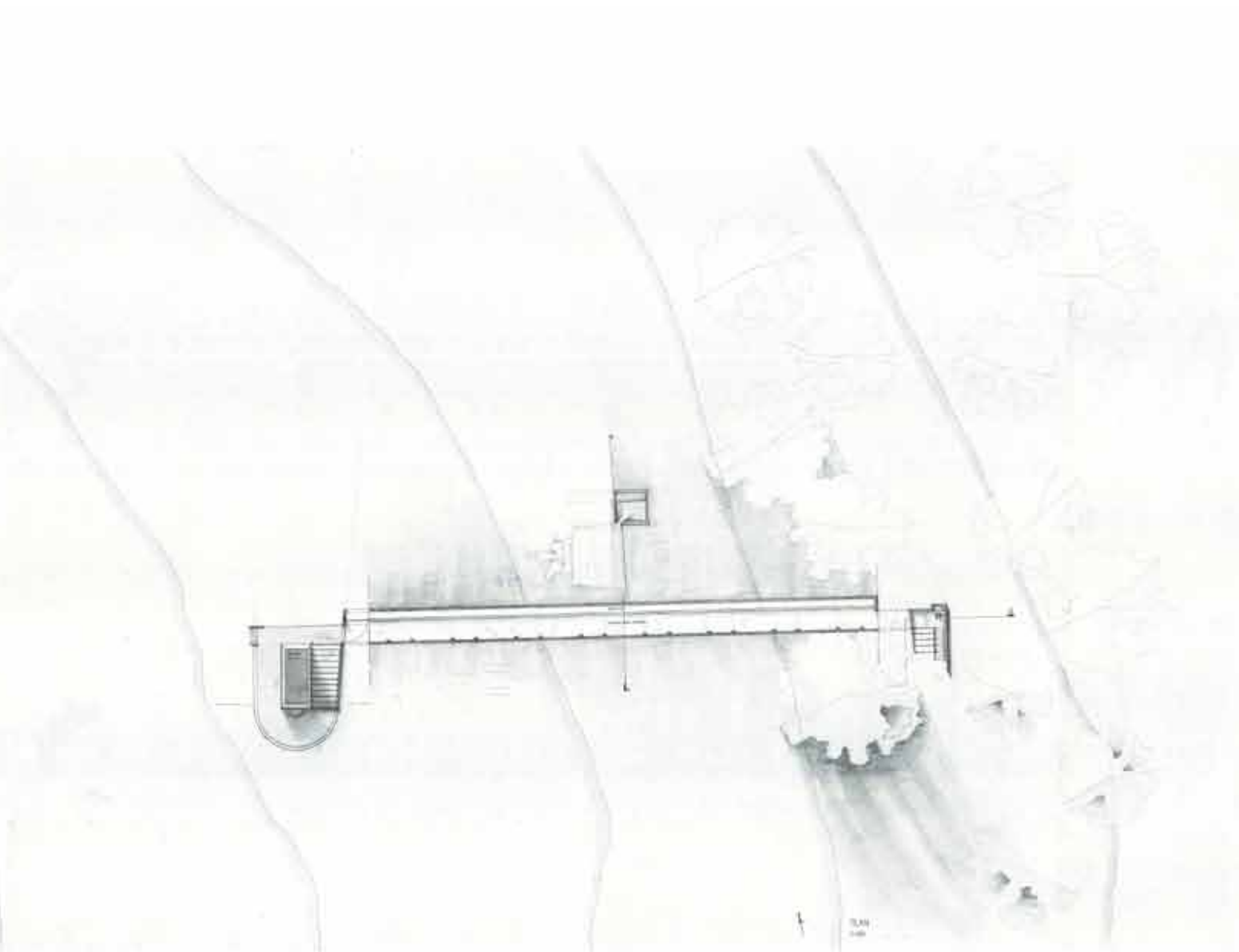
A mould was constructed from plywood and timber planks. The wax was then melted using a double boiler, and then cast in layers of 5 to 10mm. After the mould was stripped, the landscape was traced and carved with a small chisel. The Union Buildings and Church Street were added on using cardboard to serve as anchors to the model.



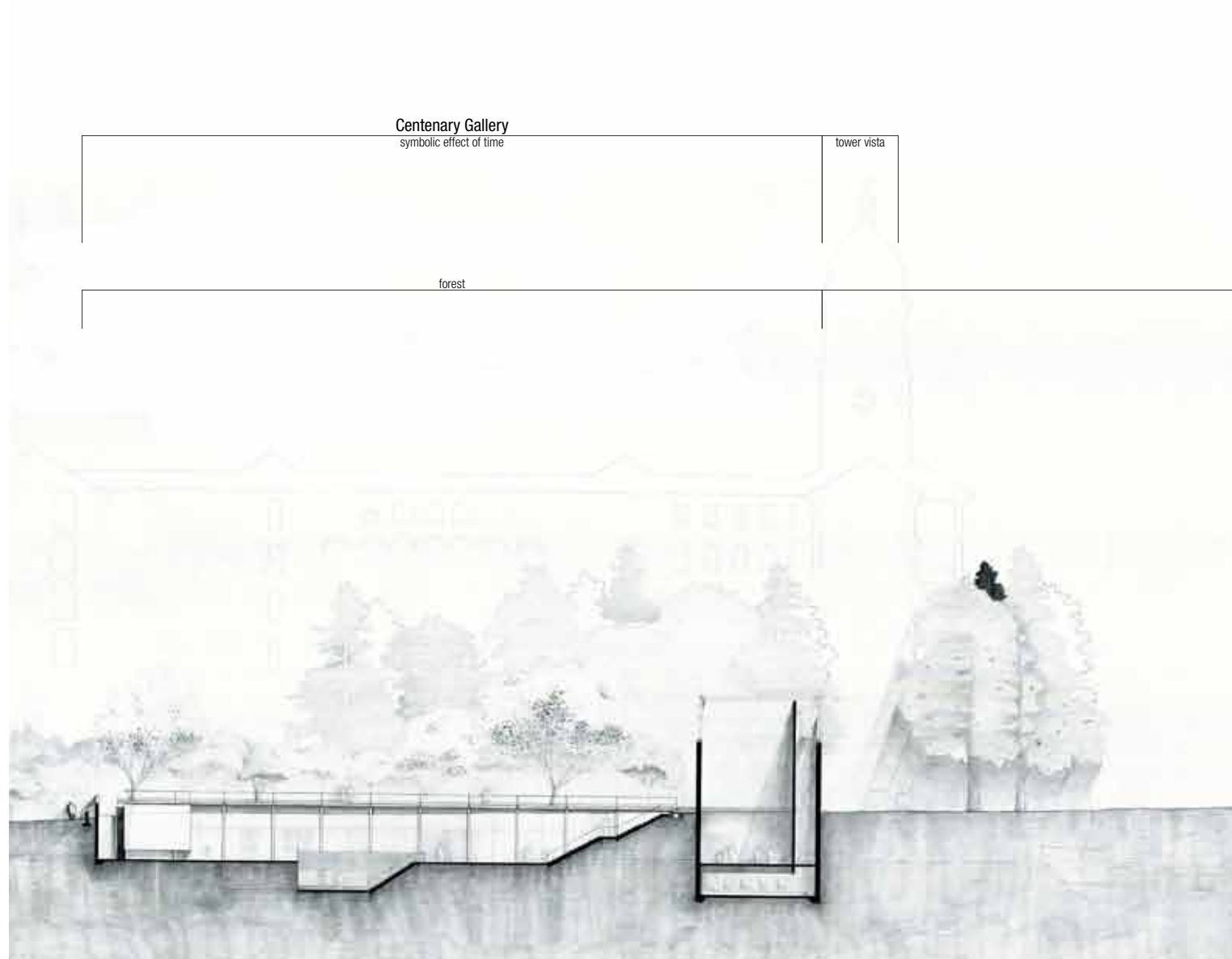
**Fig. 5.14**  
*Carving of site model*

Progress drawings





**Fig. 5.15**  
*Preliminary Plan (June)*



**Centenary Gallery**

symbolic effect of time

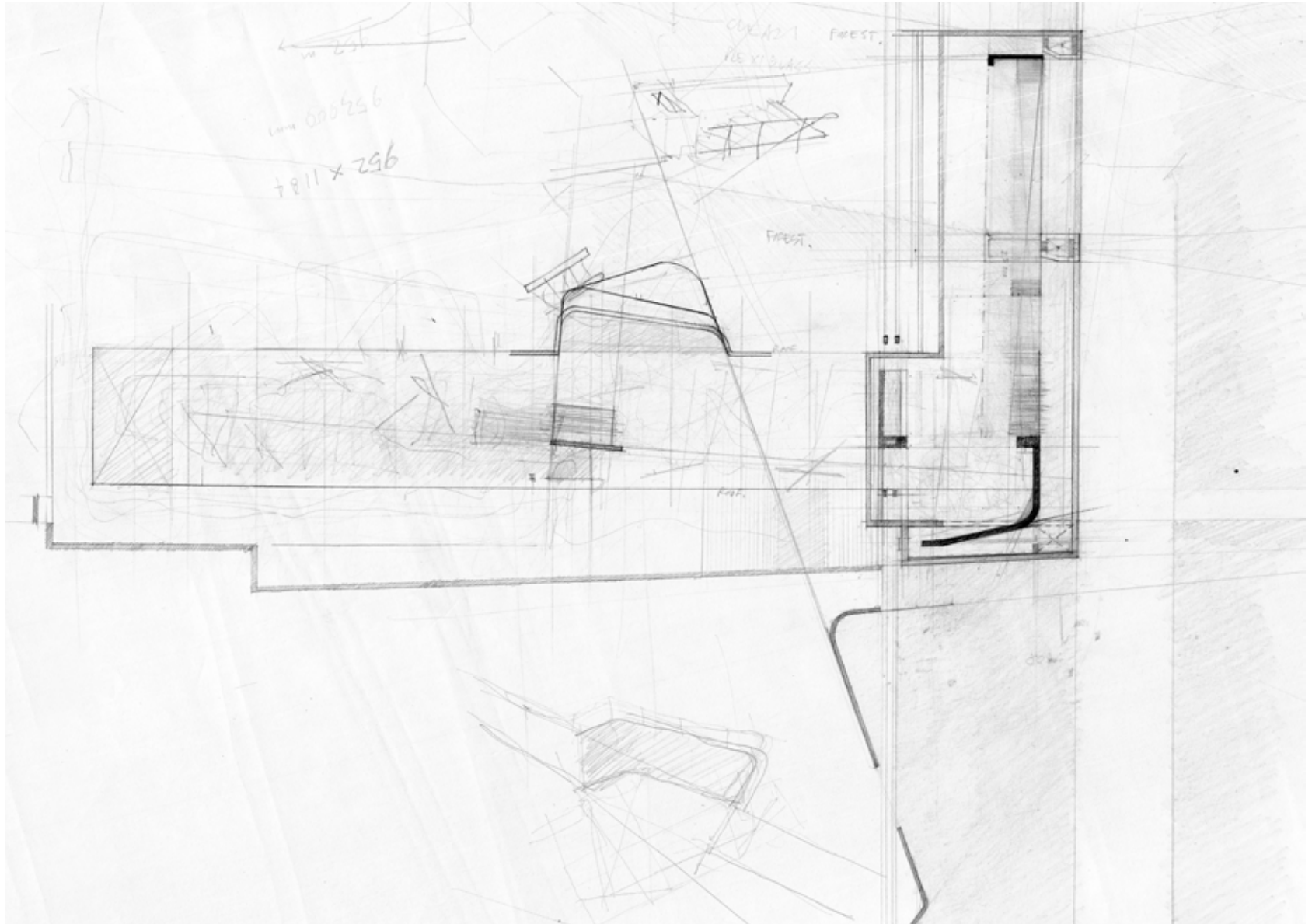
tower vista

forest

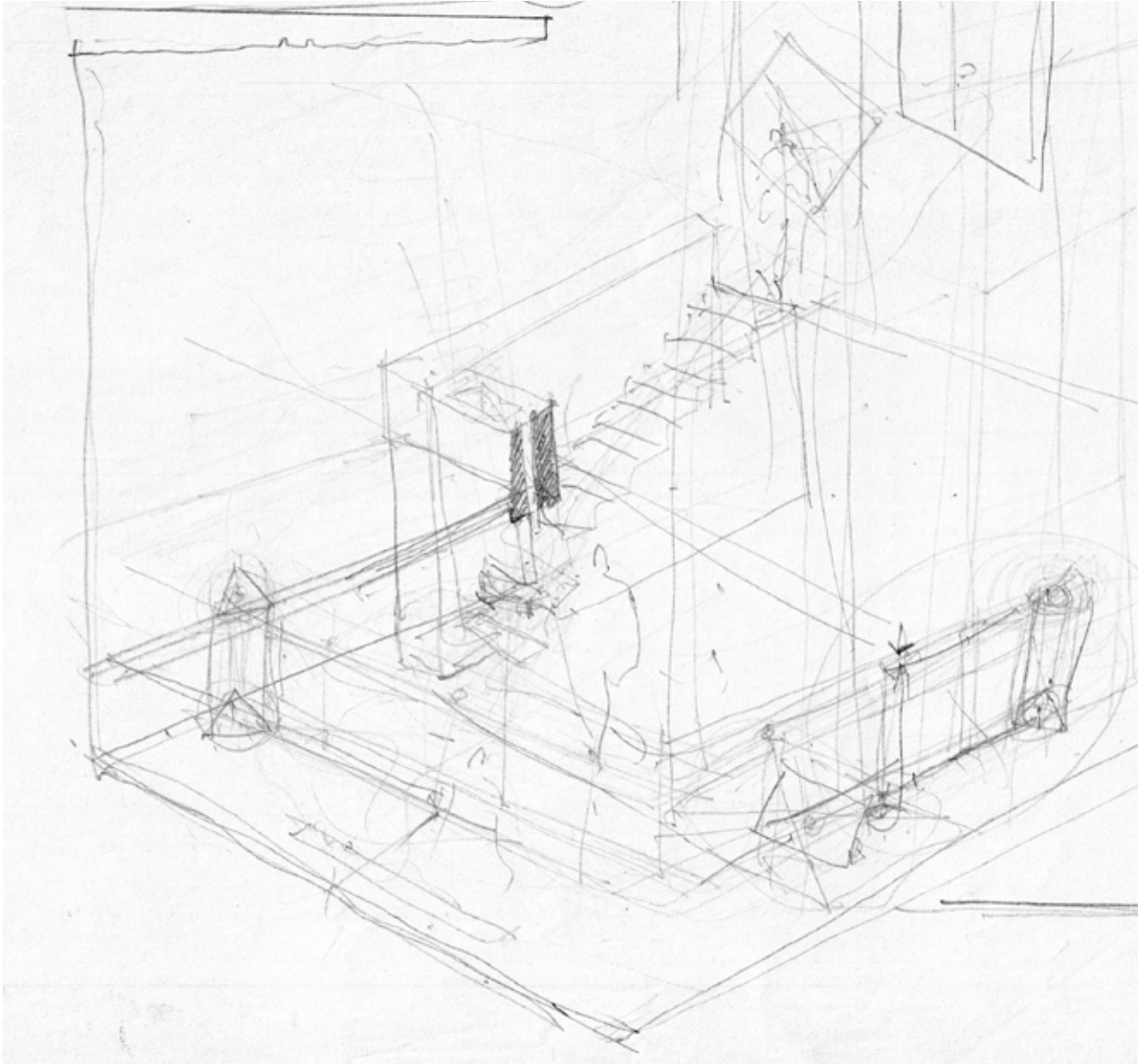


**Fig. 5.16**  
*Preliminary Section (June)*



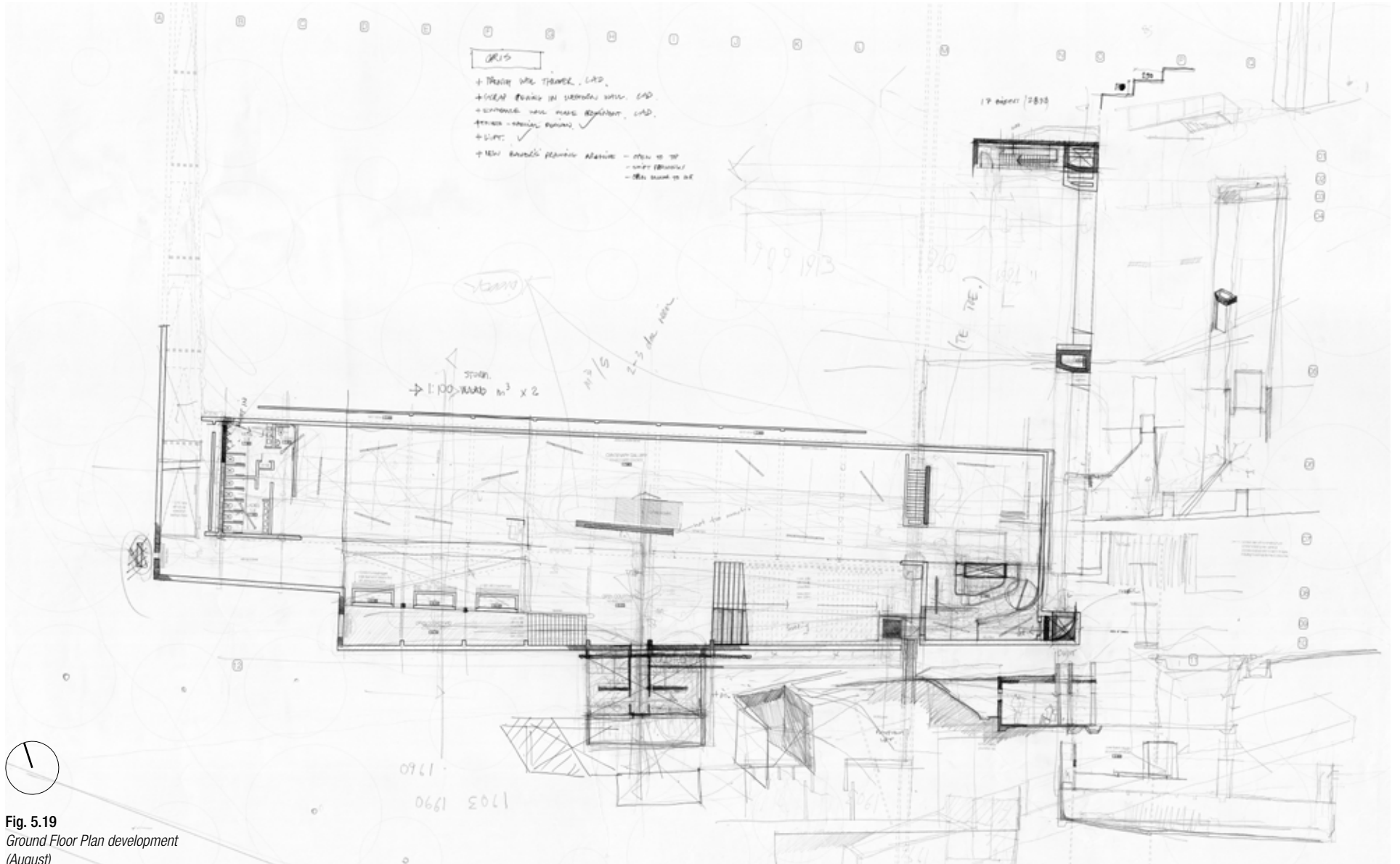


**Fig. 5.17**  
*Basement Plan development*  
*(July)*



The design process was a constant fluctuation between investigative and representative drawings. The investigative drawings challenged design ideas and the representative drawings were used to examine the implementation of these ideas.

**Fig. 5.18**  
*Basement Spatial exploration*  
(July)



**Fig. 5.19**  
Ground Floor Plan development  
(August)



## TECHNICAL RESOLUTION /06

### Introduction

Even though the aim of this dissertation is to explore architecture in its technical resolution as early as possible, a separate chapter is dedicated to the representation thereof. This chapter does not focus on contract documentation as found in practice, but rather aims at communicating the development of tectonic ideas.



**Fig. 6.1**  
*Conceptual drawing (May)*

## Tekton Approach

The concept for the tectonics is focused around the idea of the part to the whole. The part should be understood as a vital to the make-up of the whole, thus forming a collective.

Within this collective, the idea is not to create tension between stereotomic and tectonic parts, but rather to make visible the progression between these extremes. The concern is therefore on the threshold between these alternating elements. Each element has a certain weight which determines its position on this scale. This position however is not only determined by the material, but also by the fixing method used.

This concept is illustrated in Fig. 6.2 below.

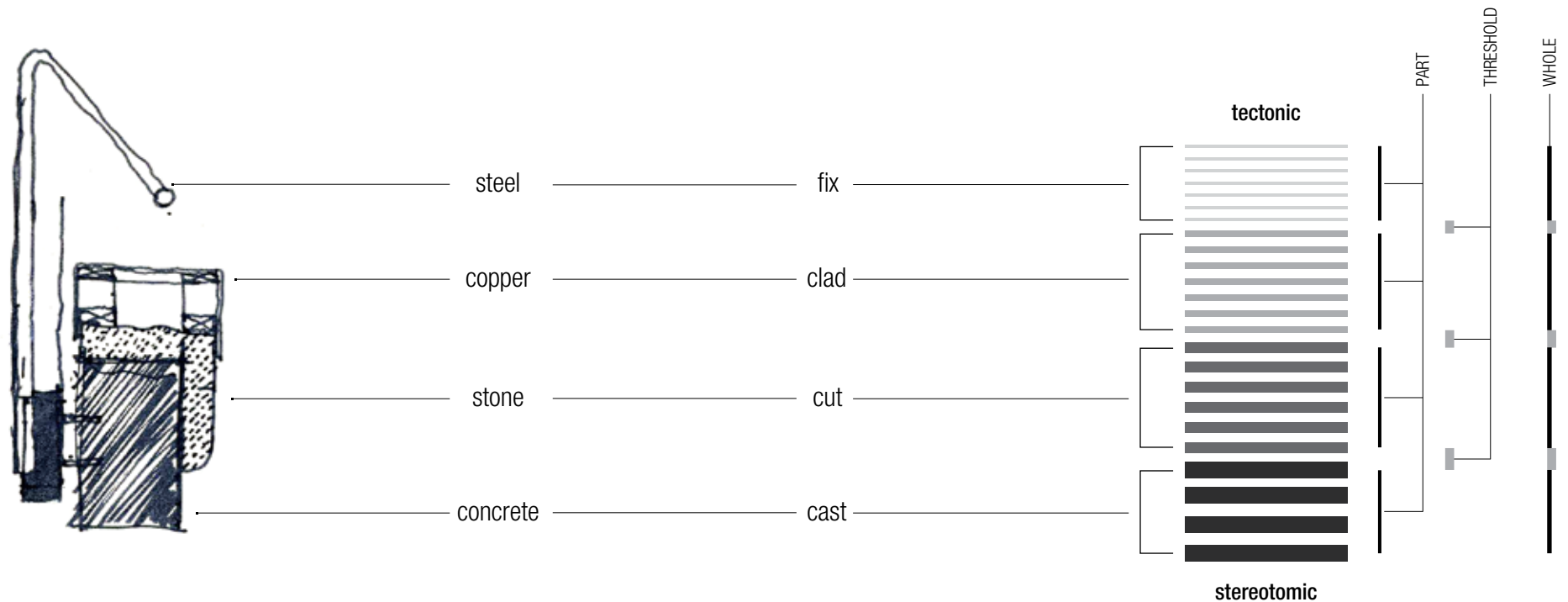


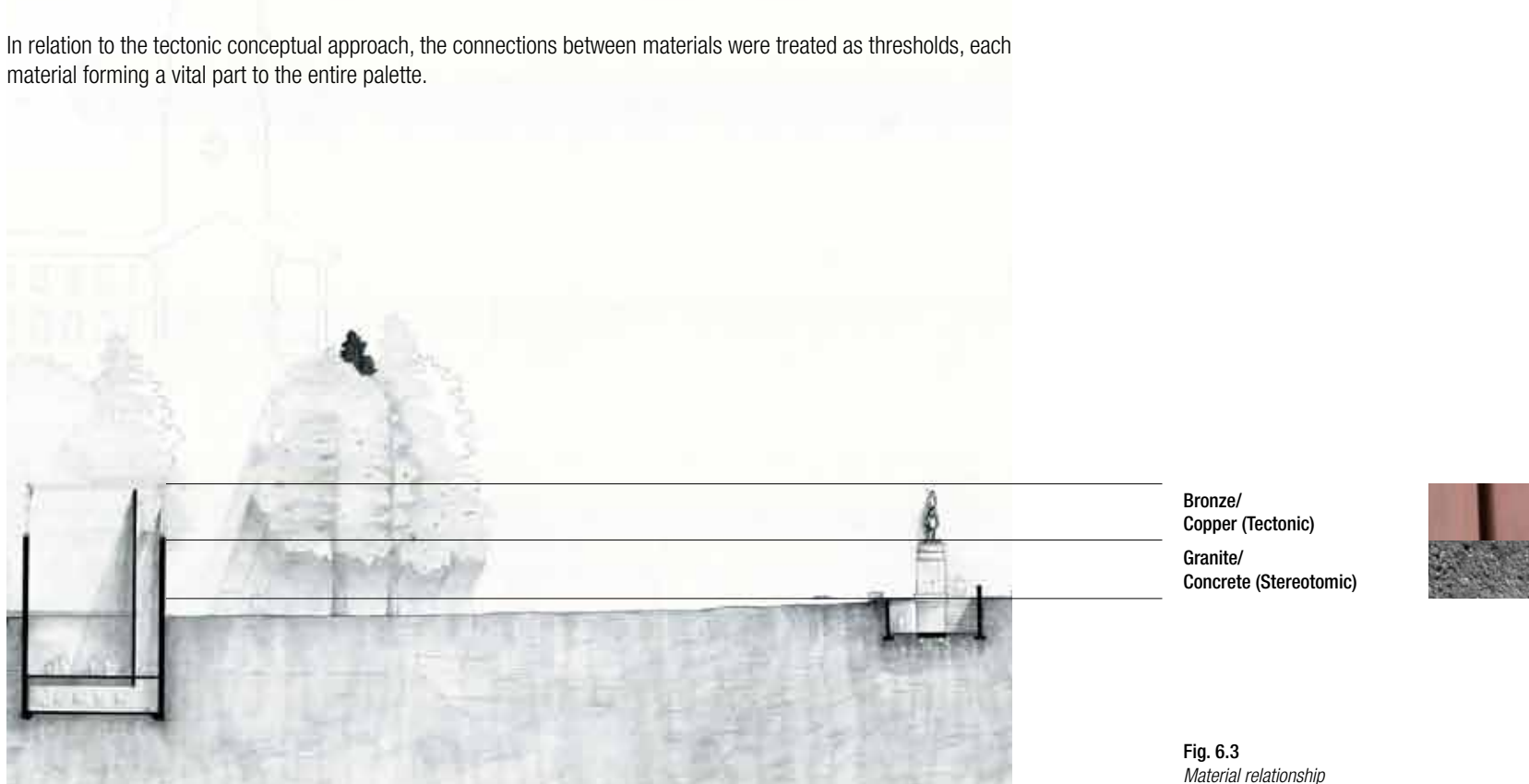
Fig. 6.2  
Tectonic Conceptual Diagram

## Material Strategy

On a material scale the focus of the scheme is to make visible the effect that time has on matter, therefore, rather than preserving, the aim is to celebrate. The material palette was selected based on the material's vulnerability over time. Copper was chosen because of the green patina formed during oxidation. Concrete was chosen as the most stereotomic material and because of its versatility in terms of finishing.

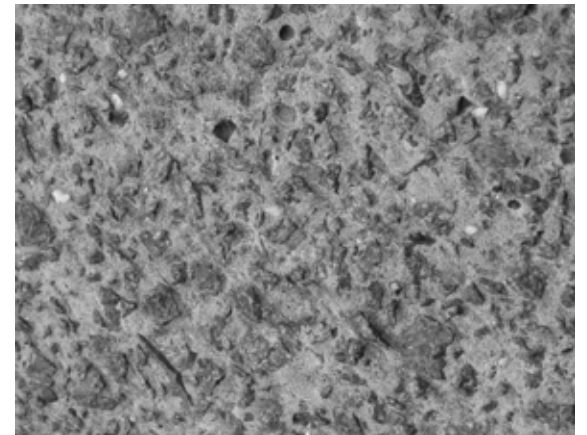
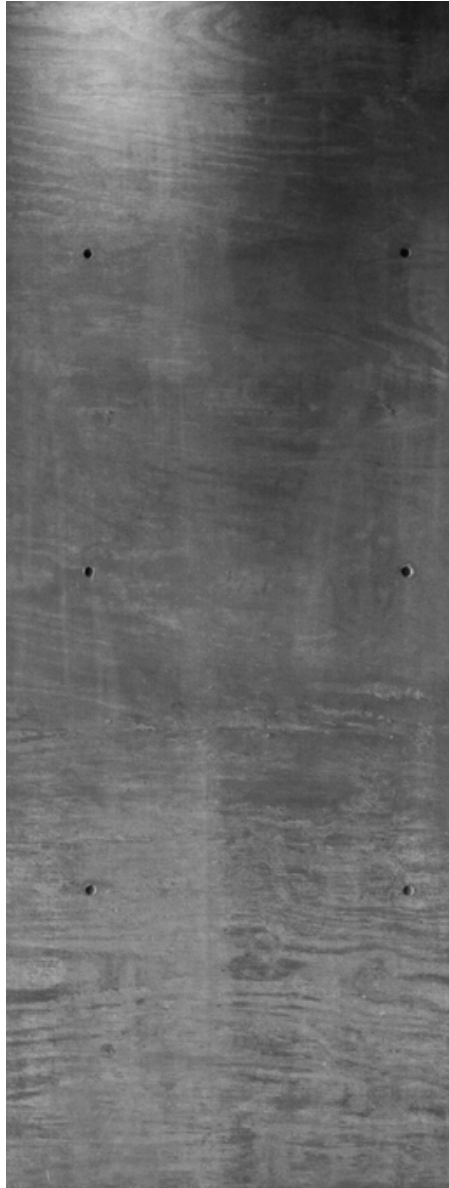
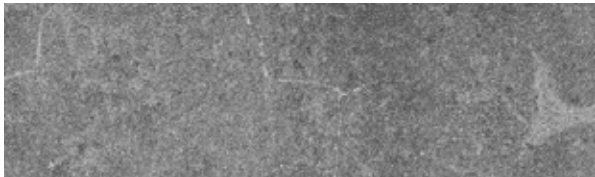
The new intervention sits in the landscape as a three dimensional antro-morphic sculpture, corresponding with the material use of the Louis Botha statue. The statue consists of a five metre high granite plinth and bronze statue. These heights were horizontally projected onto the tower of the new intervention, allowing these elements to related on a material level. This idea is illustrated in Fig. 6.3 below.

In relation to the tectonic conceptual approach, the connections between materials were treated as thresholds, each material forming a vital part to the entire palette.



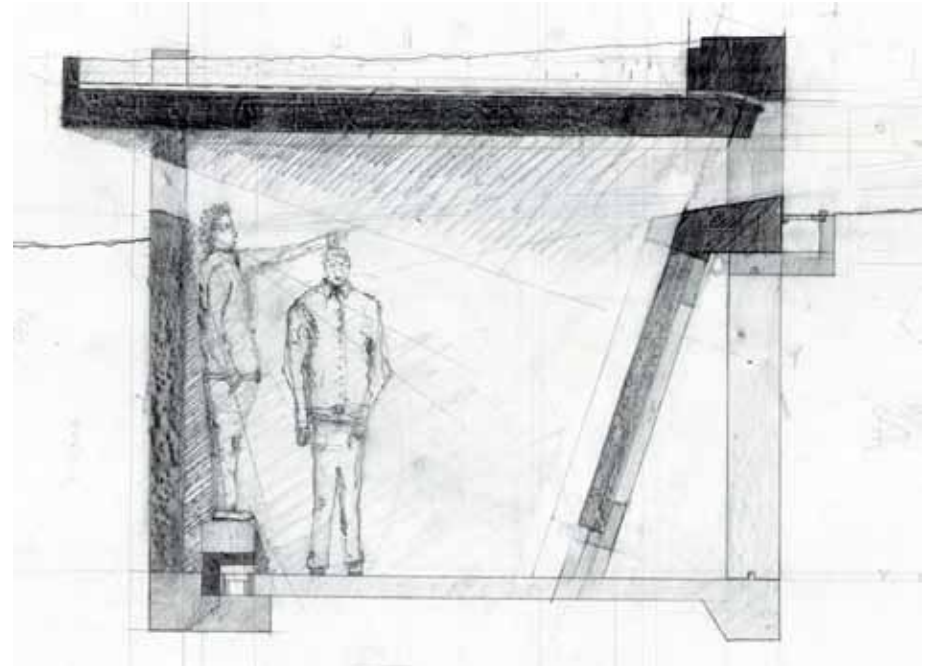
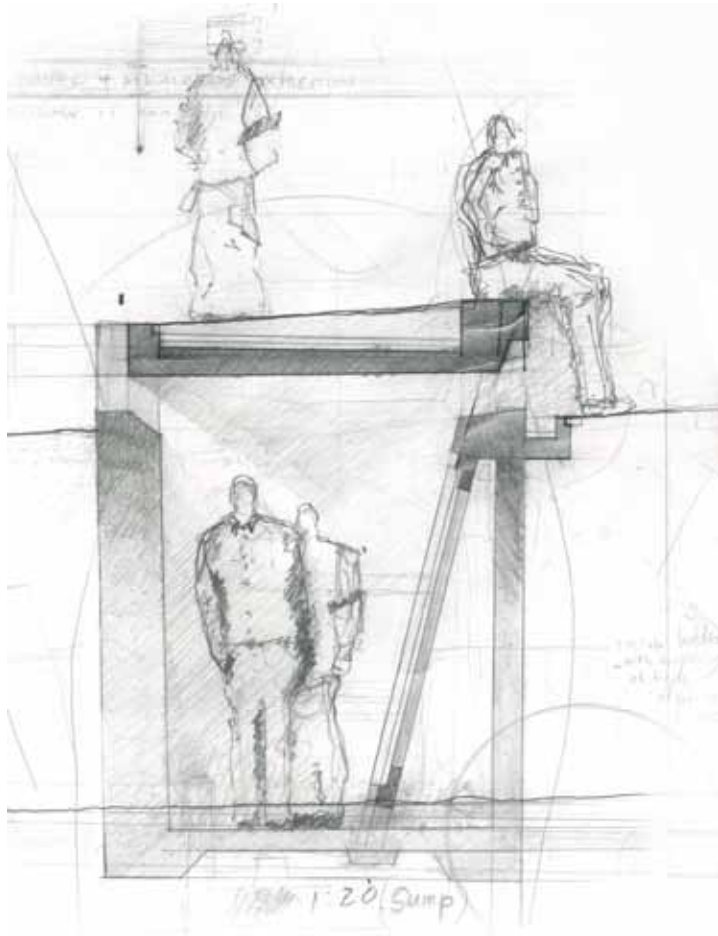
**Fig. 6.3**  
*Material relationship*

Fig. 6.4  
Material Palette

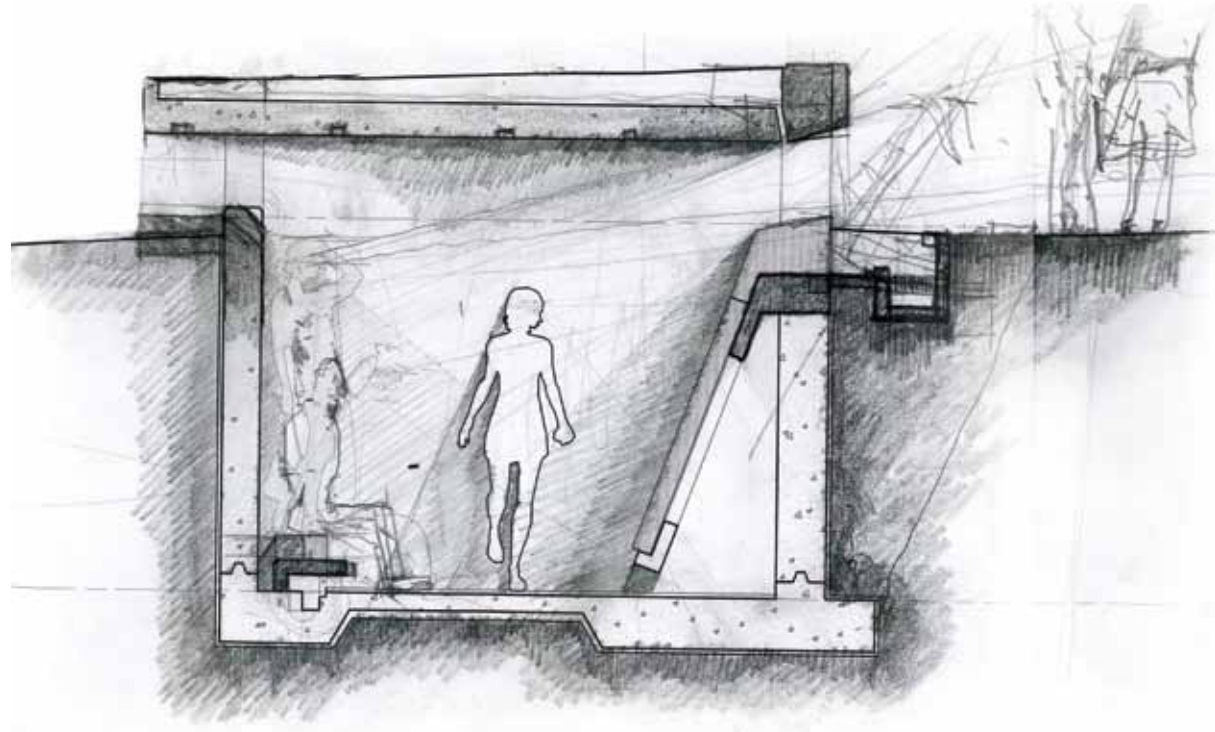




## Progress drawings



**Fig. 6.5**  
*Development of the stone memorial*  
*(July)*



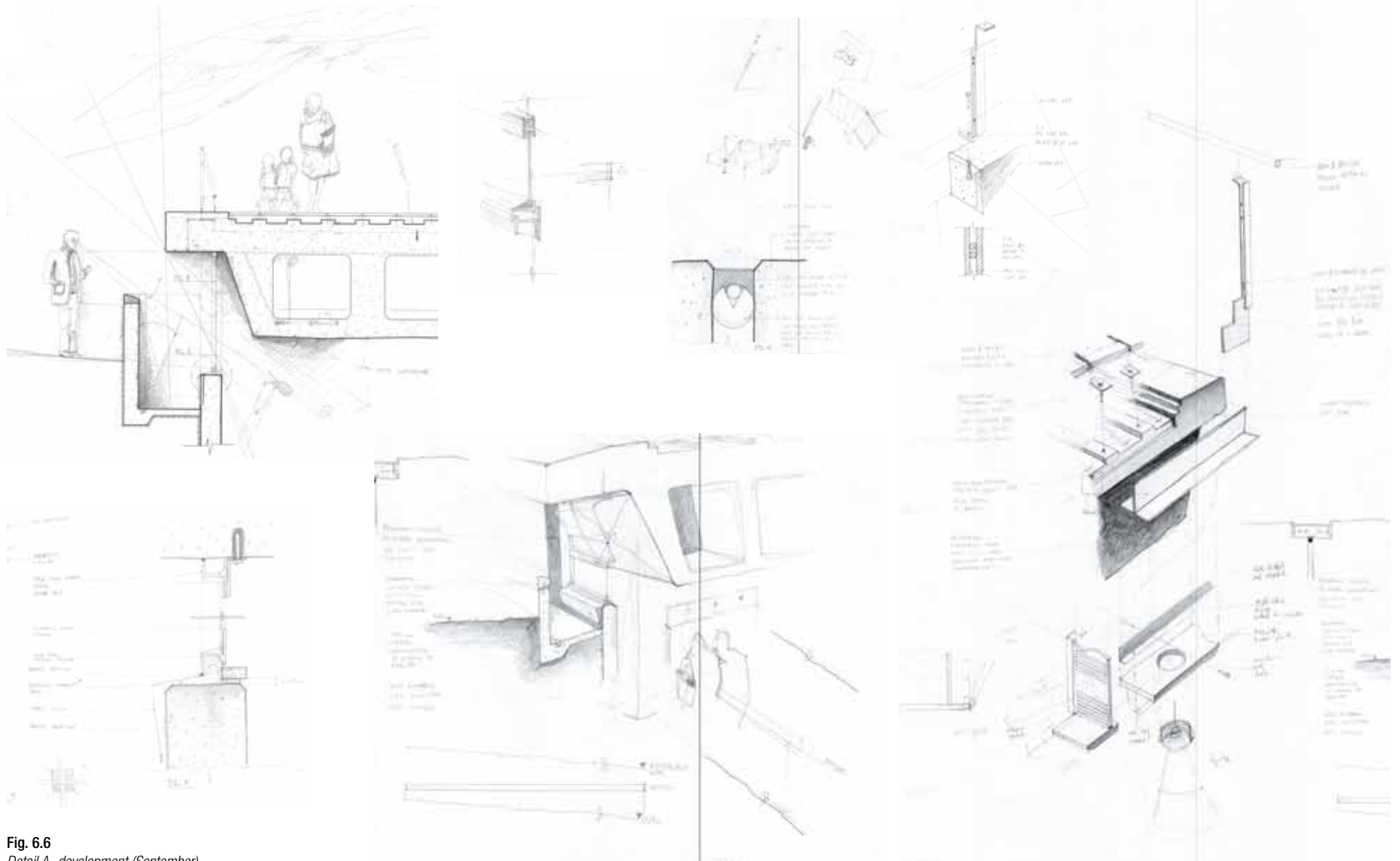
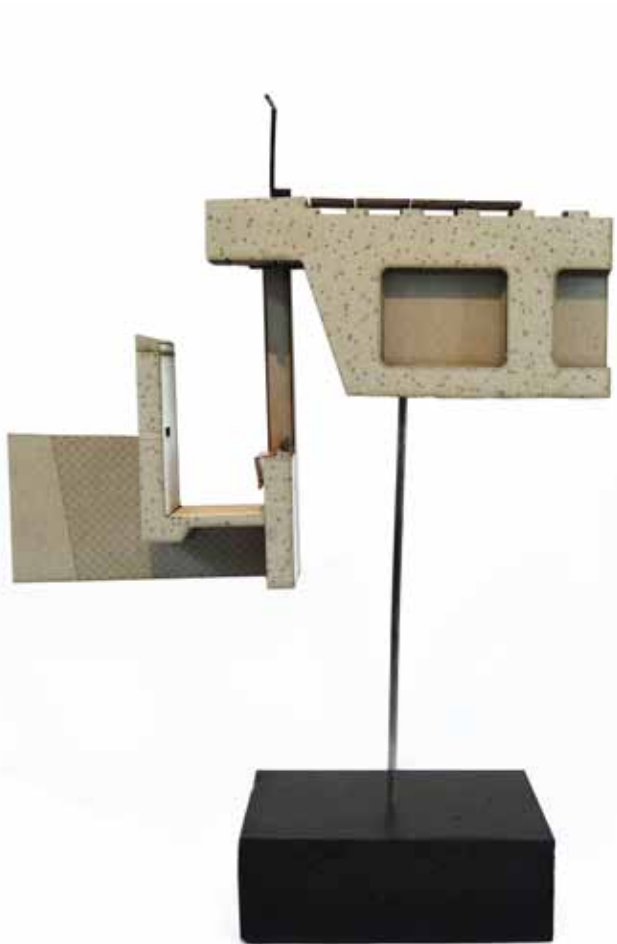


Fig. 6.6  
Detail A - development (September)



40mm diameter mild steel hollow circular section handrail welded to 2x 40x5 mild steel flatbar uprights

Concrete gutter system

Reinforced concrete roof with ABE 'dura proof' waterproofing admixture.

Custom mild steel T-beam, shop welded. Painted with black enamel paint to manufacturer's specification

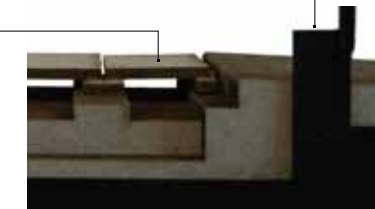
600x420x40 Precast concrete tiles, sandblasted to ensure glare and slip free finish to rest on steel spacers

Adjustable galvanised steel spacer fixed into concrete roof with structural 'dry-to-dry' epoxy

Sandstone coping fixed with steel dowels

Copper sheet cill weathering folded over waterproofing

HB LED strip lighting cast into concrete trench



**Fig. 6.7**  
*Detail A- representation model*  
*(October)*

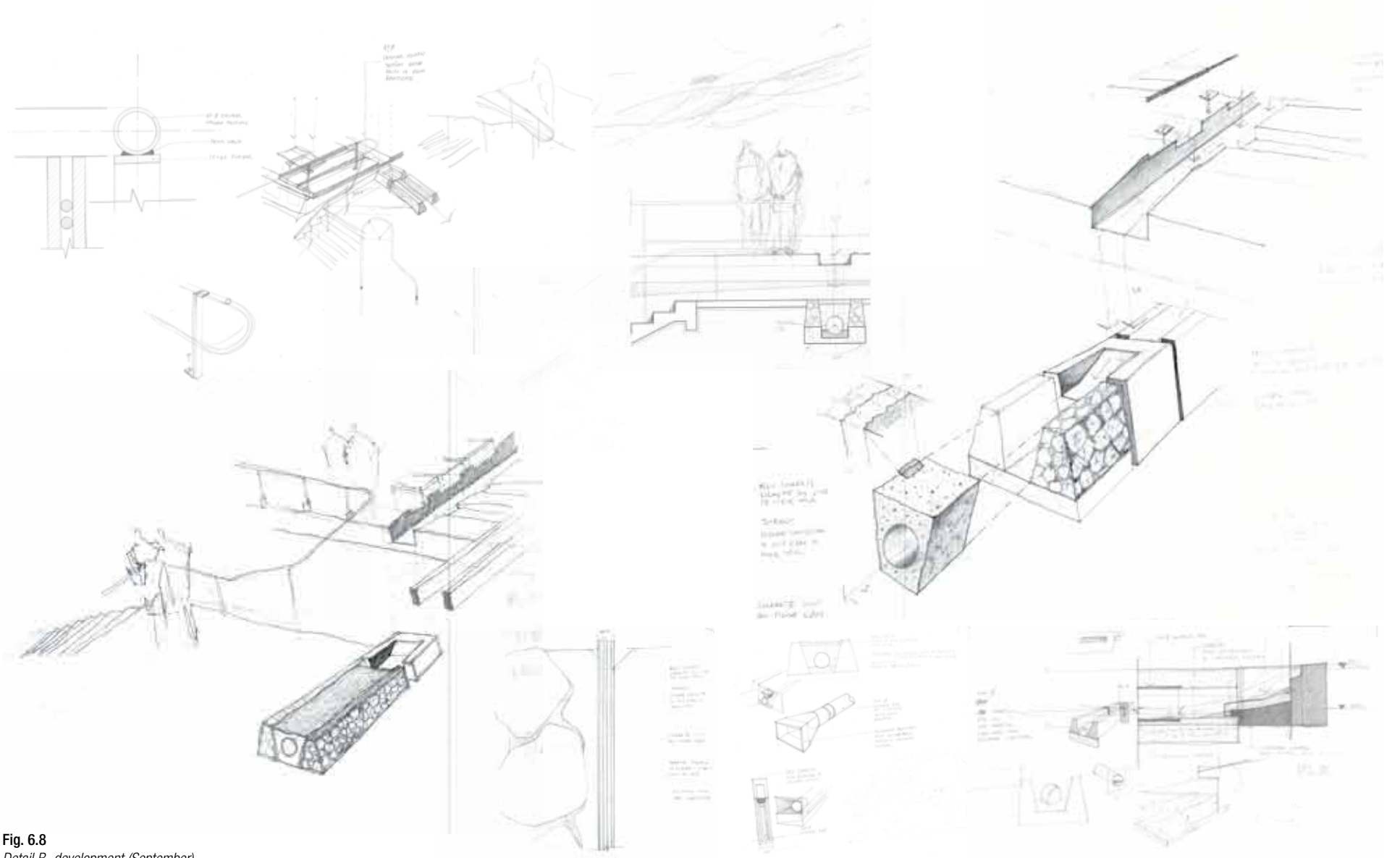


Fig. 6.8  
Detail B- development (September)



40mm diameter mild steel hollow circular section handrail welded to 2x 40x5 mild steel flatbar uprights

Concrete gutter

Existing stone trench

300 concrete storm water pipe

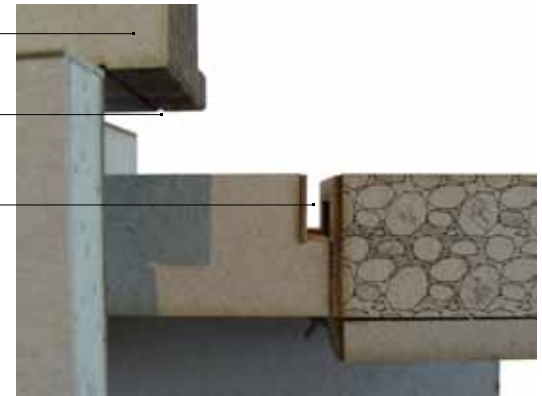
Existing trench foundation



Reinforced concrete roof slab with ABE 'dura.proof' waterproofing admixture

Concrete recessed drip line

Shadow line connection between new and existing materials



**Fig. 6.9**  
*Detail B- representation model*  
*(October)*





**Fig. 6.11**  
*Detail C- representation model*  
*(October)*



## CONCLUSION /07

### Representational Drawings

The drawings in this chapter were made to serve, as both design and technical drawings. They should be understood as tools of representation, communicating the collective intention of the scheme on an architectural scale.

These drawings/models and photos serve as concluding material for this dissertation and should be viewed as an attempt to represent this architectural scheme in its most final format possible.

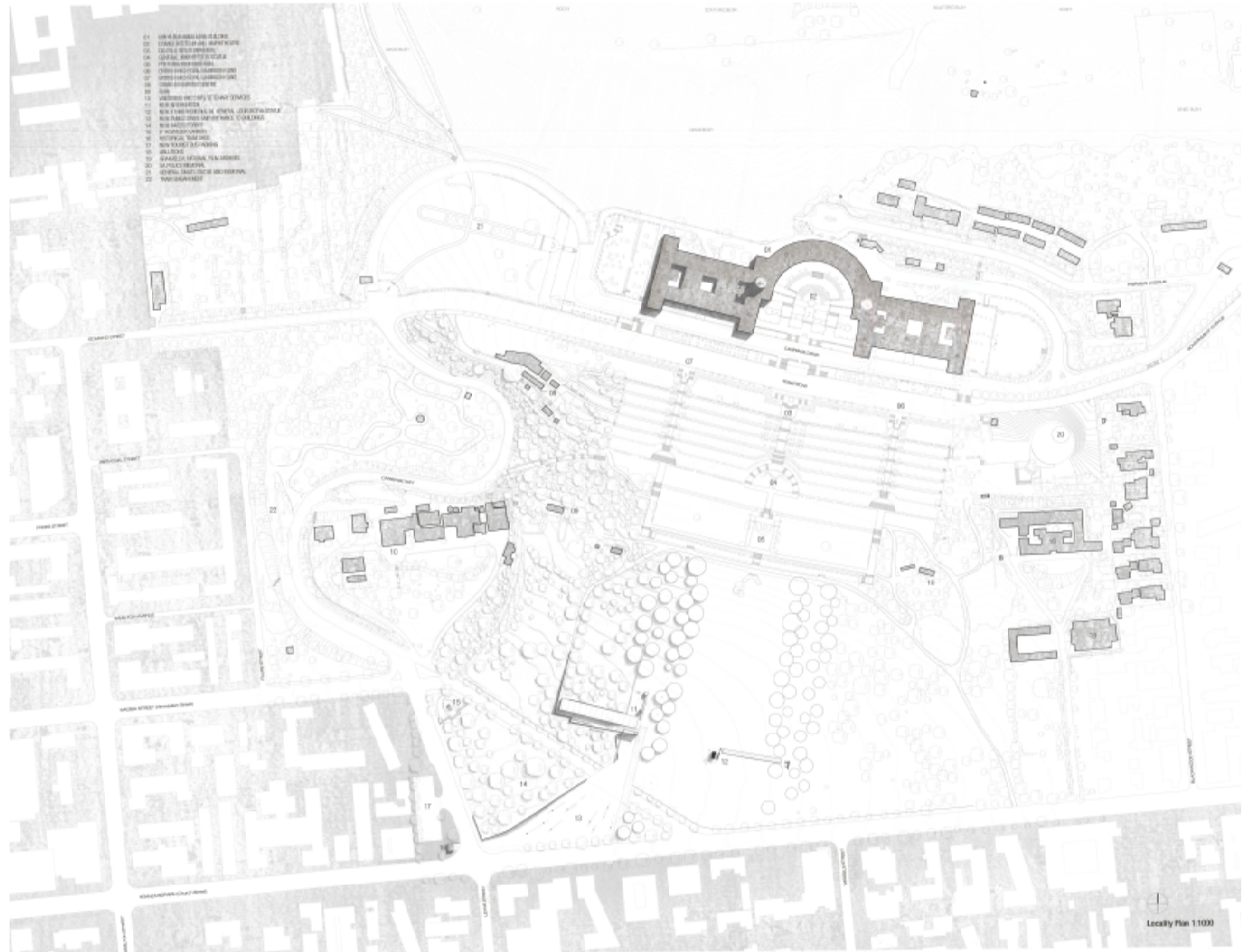
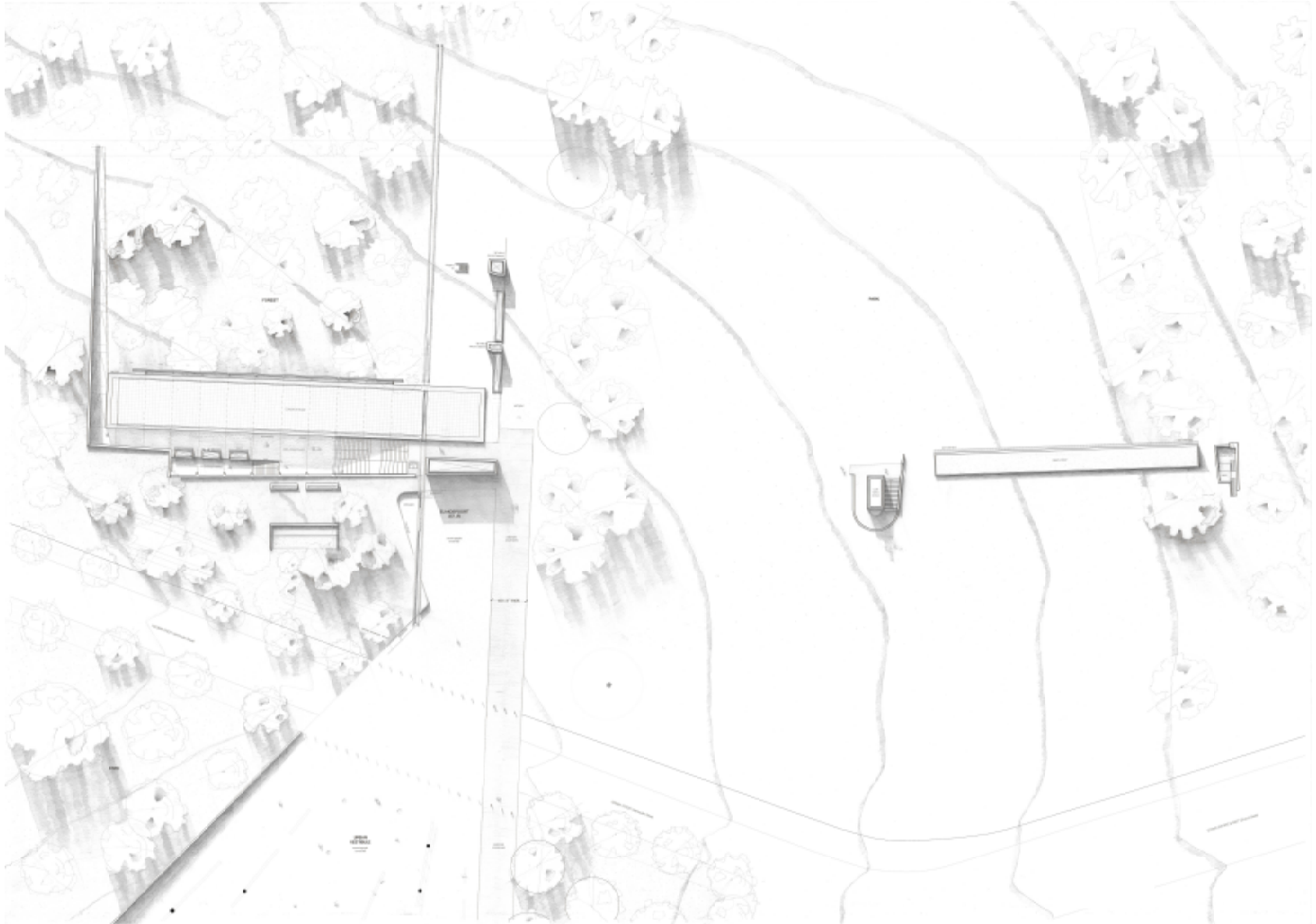
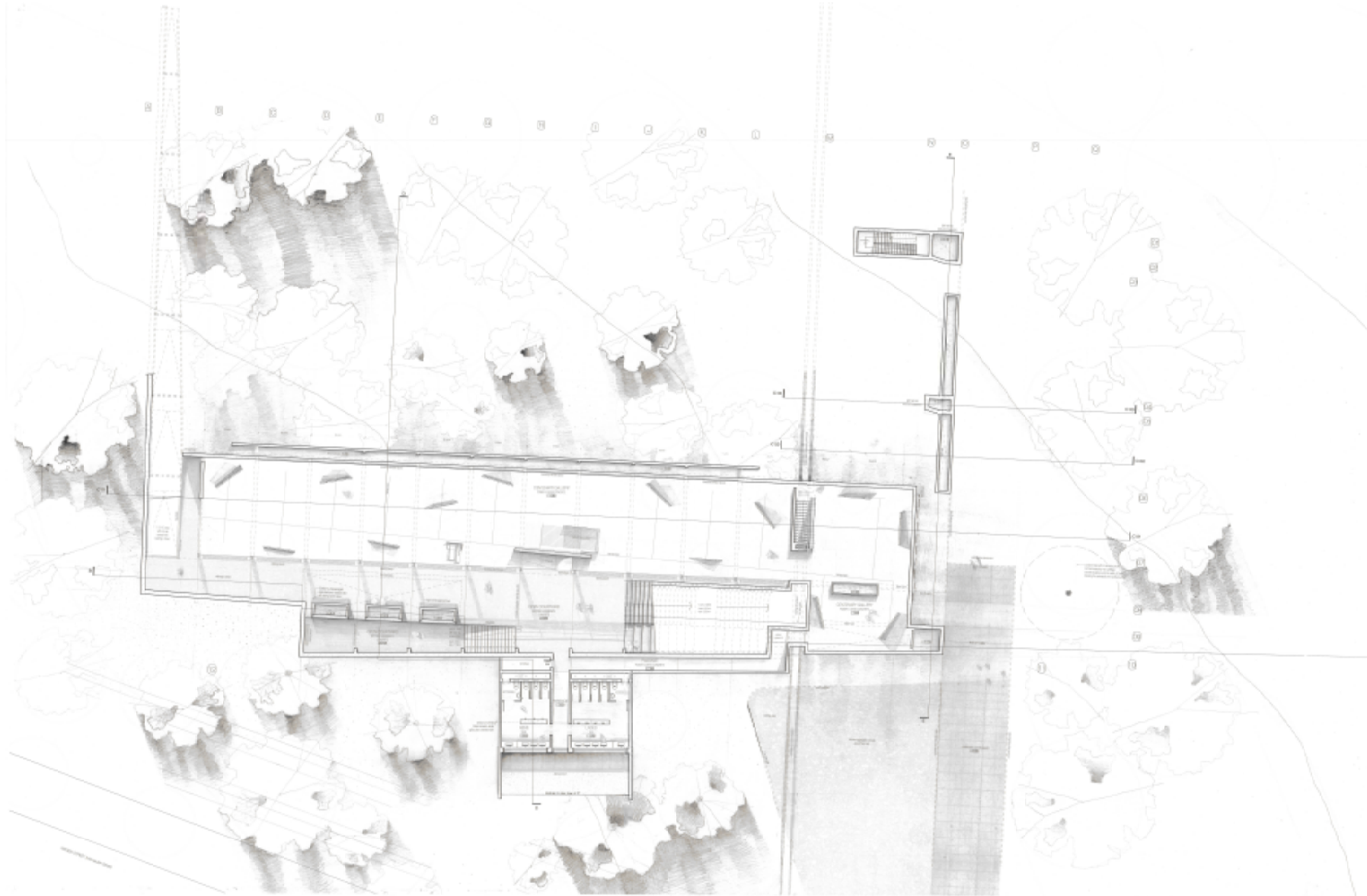
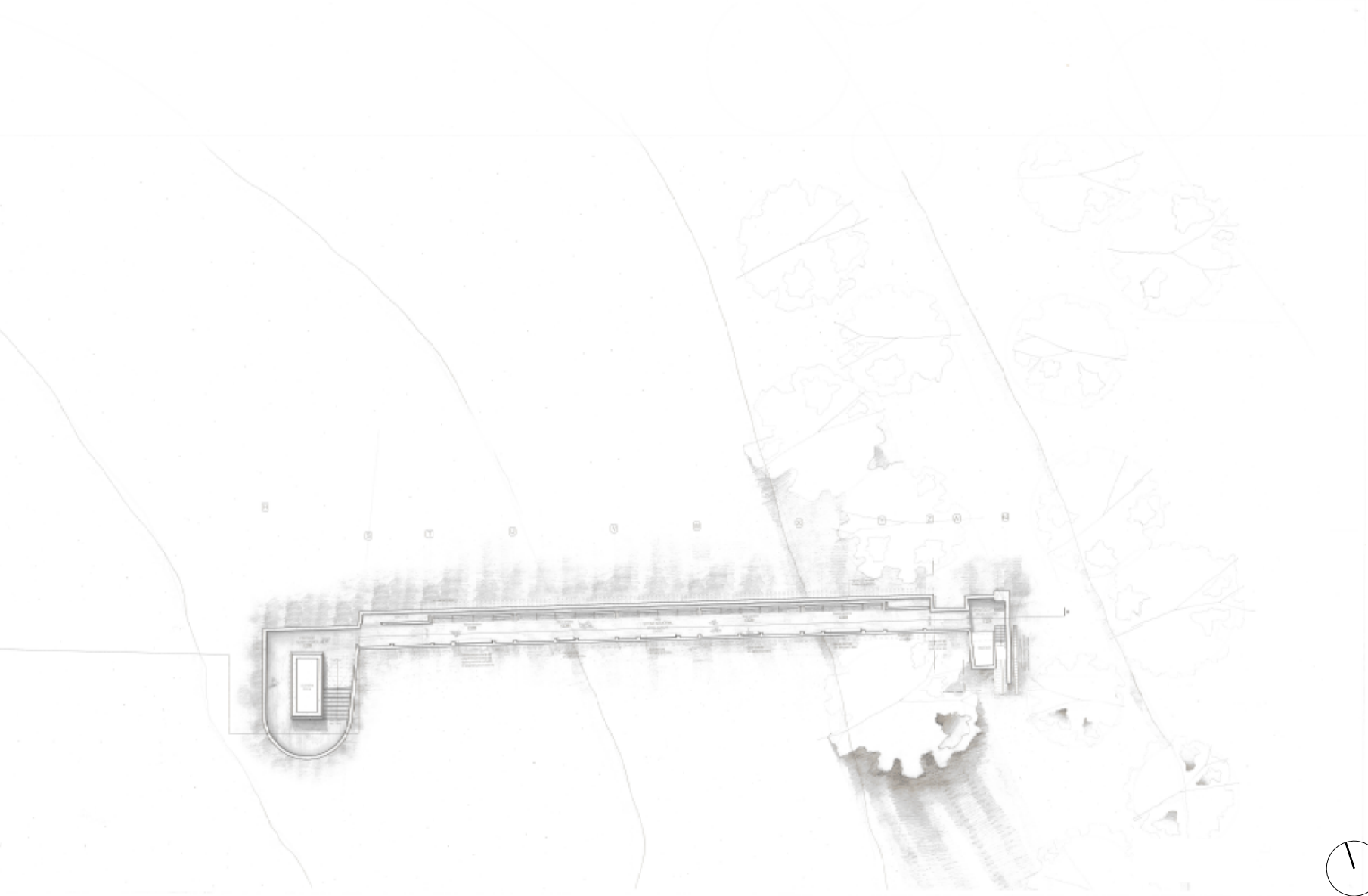


Fig. 7.1 Locality Plan

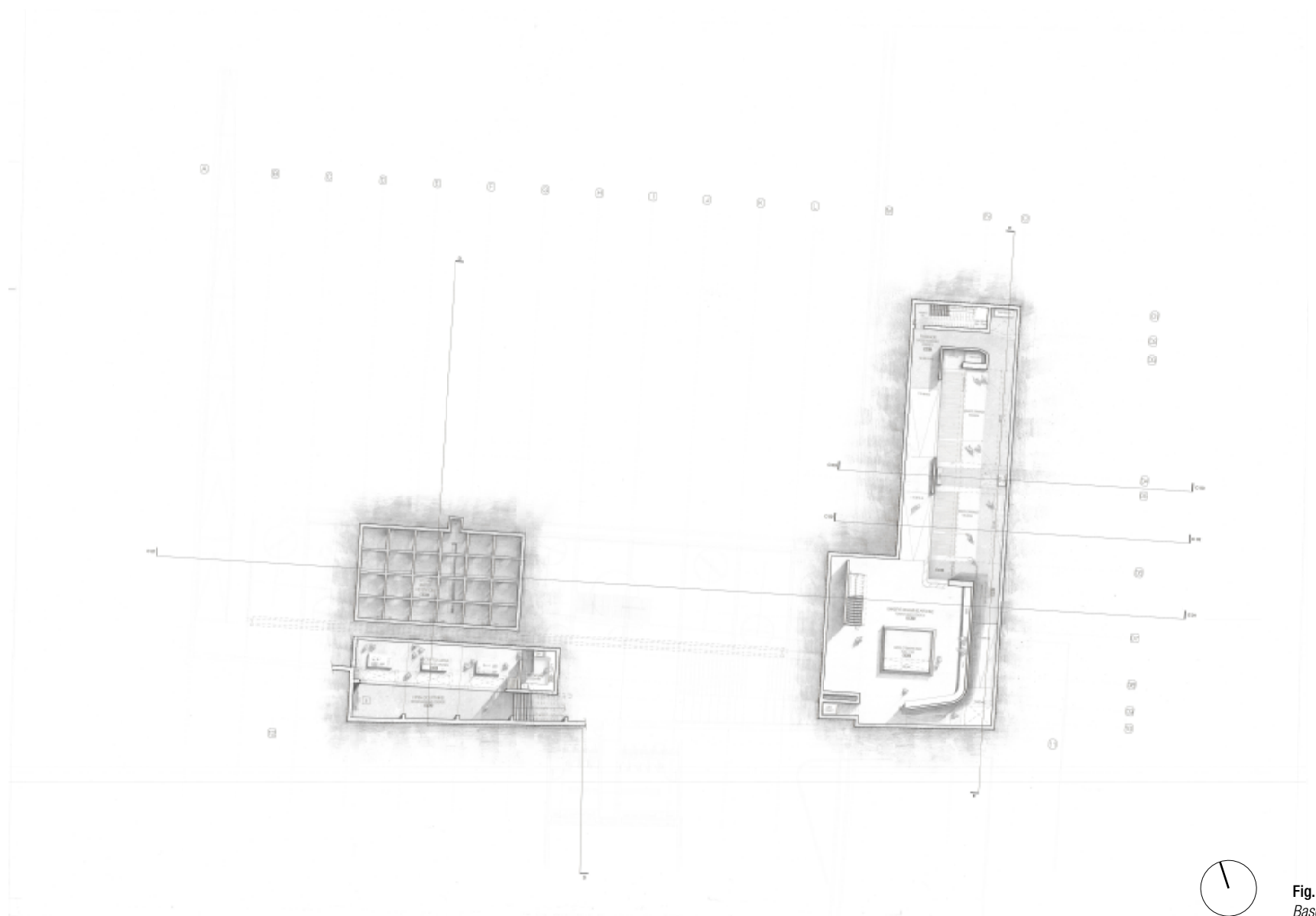


**Fig. 7.2**  
*Site Plan*





**Fig. 7.3**  
*Ground Floor Plan*



**Fig. 7.4**  
*Basement Plan*

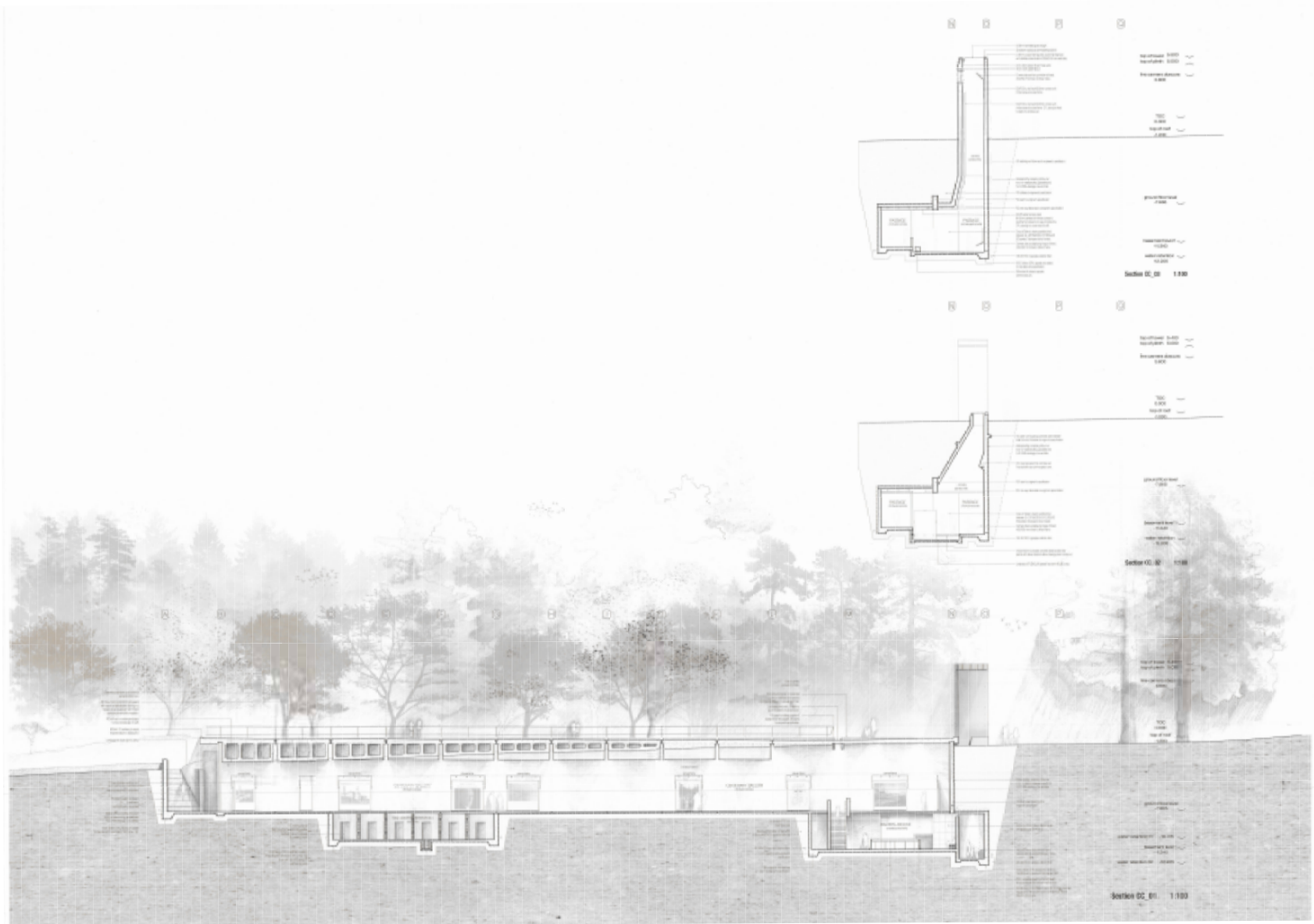
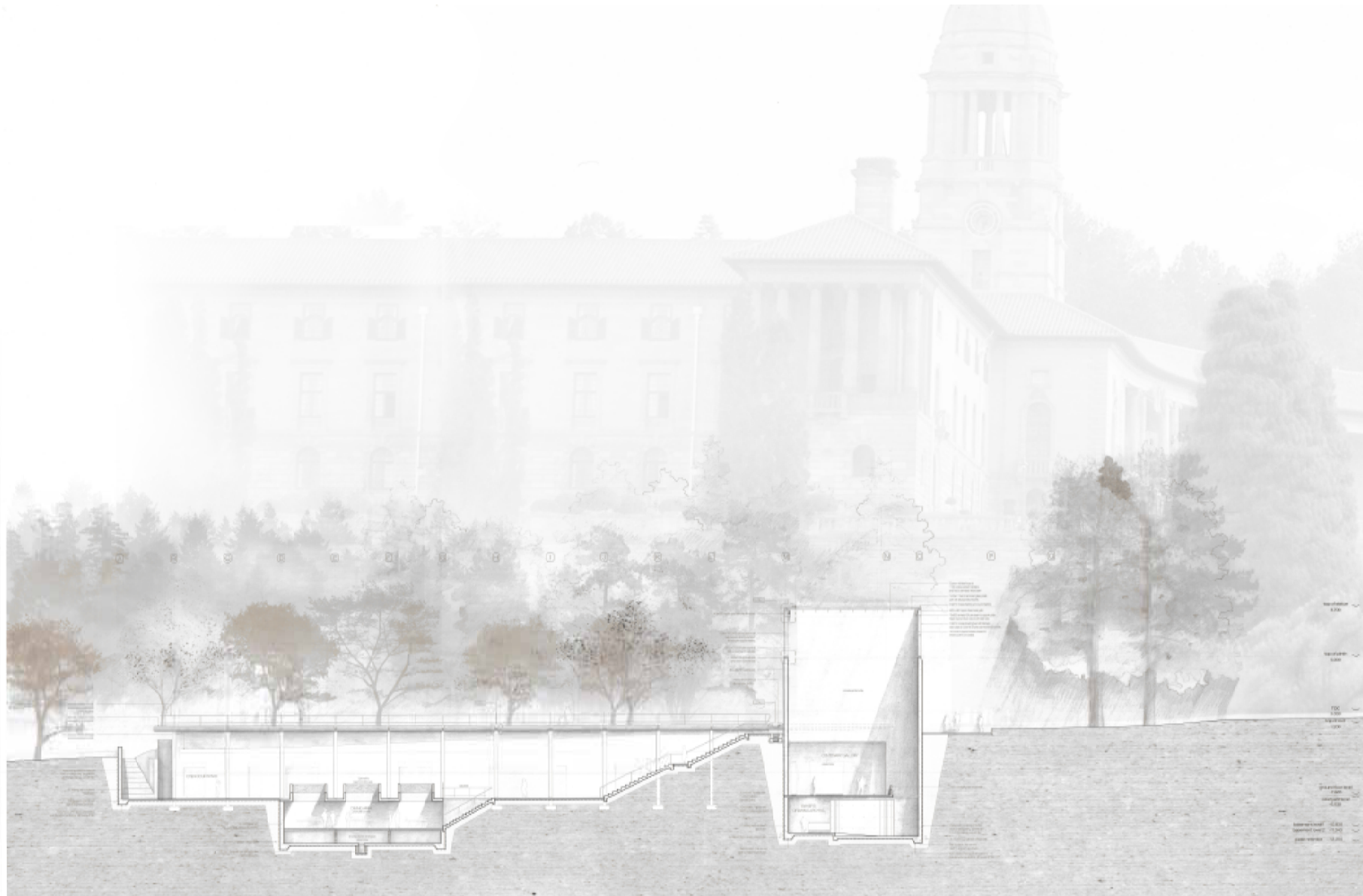


Fig. 7.5  
Section CC





**Fig. 7.6**  
*Section BB*





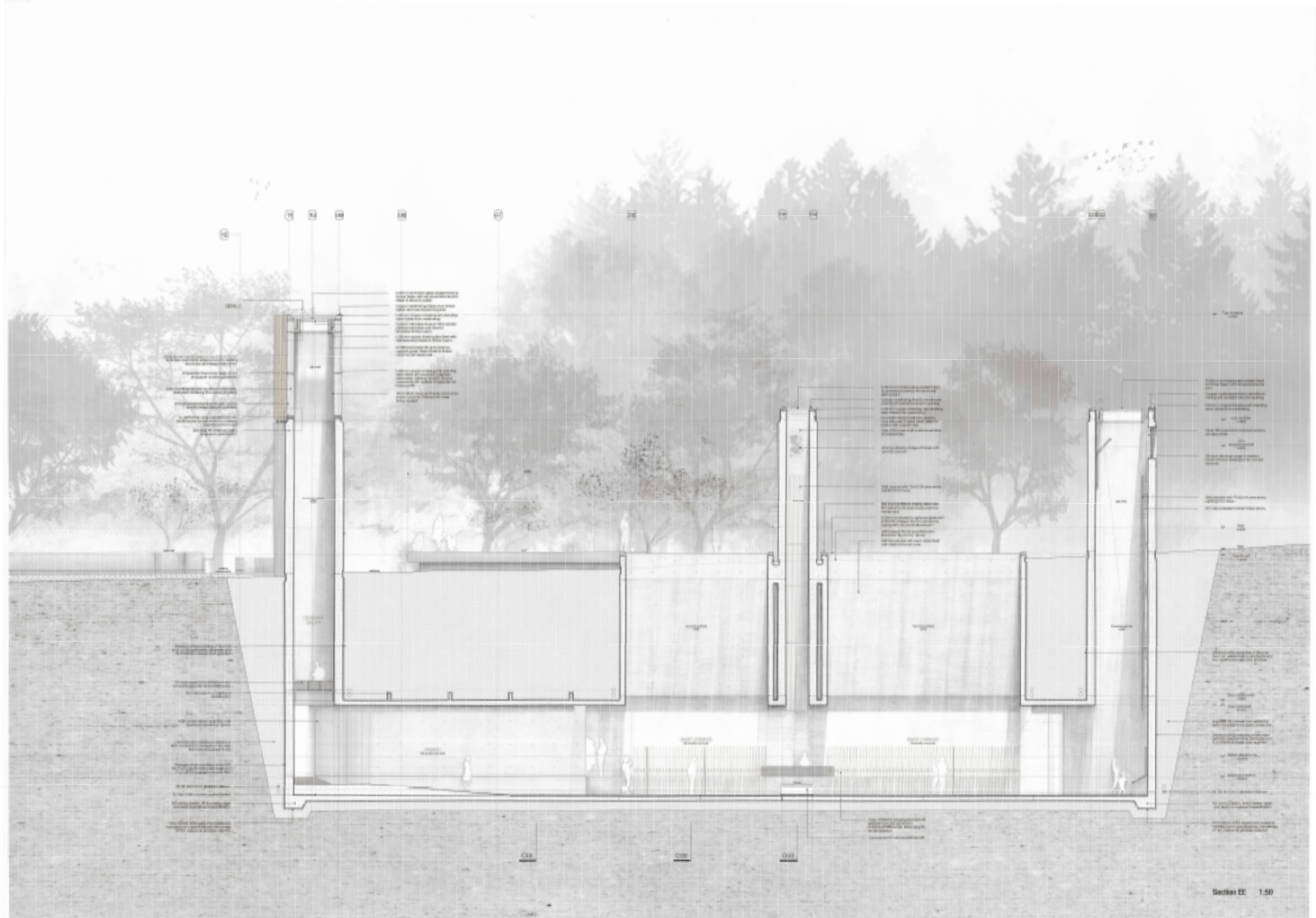


Fig. 7.8  
Section EE



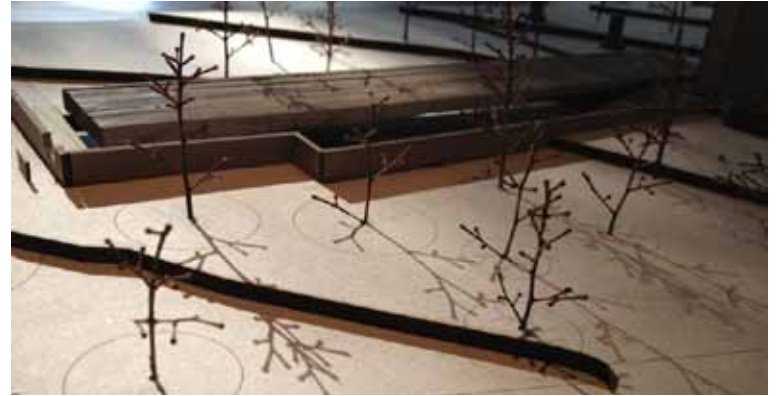
Fig. 7.9  
Section FF



*Site Model photos*

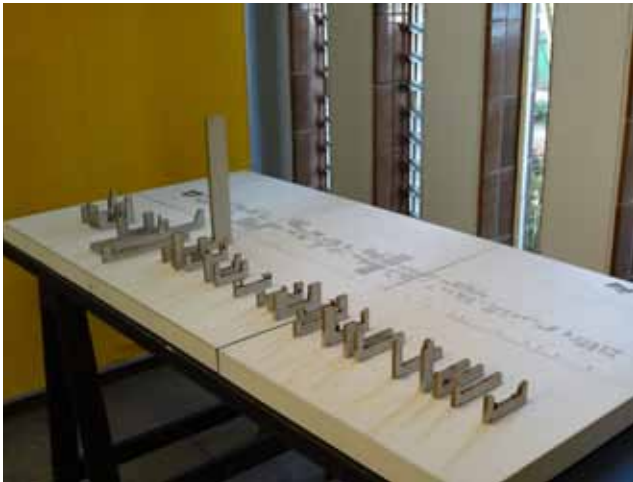




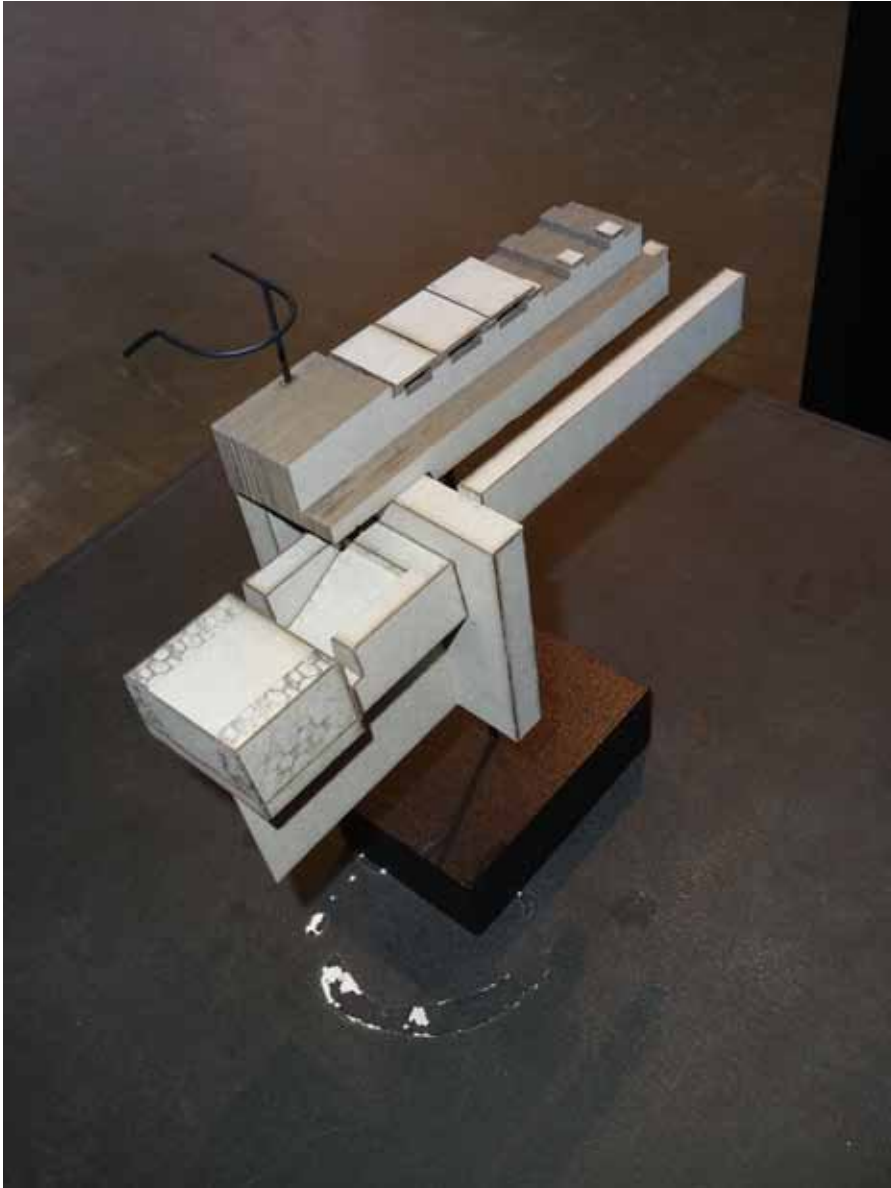








Photos of exam  
2012-11-15





## BIBLIOGRAPHY /

- Allison, P. (Ed.). 2006. David Adjaye Making Public Buildings: Specificity, Customization, Imbrication. London: Thames & Hudson.
- Bagnoli, B. A. 2006. Drawings: Carlo Scarpa. <http://prattinteriordesign.blogspot.com> [Accessed: 24 May 2011].
- Baker, H. 1909. Letter to General Louis Botha, 26 June (item 07673, Archive, Department of Architecture, University of Pretoria).
- Baker, H. 1909. Letter to Public Works Department, 25 September (item 07679, Archive, Department of Architecture, University of Pretoria).
- Botha, P.W. 1989. Die Uniegebou: Die Eerste 75 jaar. Pretoria: Staatsdrukker.
- Crippa, M.A. 1984. Carlo Scarpa: Il Pensiero Il Disegno I Progetti. Milano: Jaca Book.
- Dezeen. 2006. Thomas Heatherwick on his studio's Christmas cards. <http://www.dezeen.com/2012/06/13/movie-thomas-heatherwick-on-his-studios-christmas-cards/> [Accessed: 07 August 2012].
- EL Croquis Editorial. 2005. Enric Miralles: 1983- 2000. Madrid: El Croquis Editorial.
- Famous Architects. Carlo Scarpa. <http://architect.architecture.sk/carlo-scarpa-architect/carlo-scarpa-architect.php> [Accessed: 1 May 2012].
- Field, L. 2009. The Temporal Dimension of Architecture. Unpublished Master thesis. Cincinnati: University of Cincinnati,
- Frampton, K. 1995. Studies in Tectonic Culture: The Poetics of Construction in Nineteenth and Twentieth Century Architecture. Cambridge: MIT Press.
- Leith, G. 1928. Union Buildings: Architects' views on extension proposals. Johannesburg Star, 8 December.
- MoMA. 2011. The Collection. <http://www.moma.org> [Accessed: 3 May 2012].
- Mostafavi, M. and Leatherbarrow, D. 1997. On Weathering- The Life of Buildings in Time. Massachusetts: MIT Press.
- Murphy, R. 1990. Carlo Scarpa and the Castelvechio. London: Butterworth Architecture.
- Ots, E. 2011. Decoding Theoryspeak: An Illustrated Guide to Architectural Theory. New York: Routledge.

Pallasmaa, J. 1996. *The Eyes of the Skin: Architecture and the Senses*. London: Academy Editions.

Pallasmaa, J. 2000. *Hapticity and Time: Notes on Fragile Architecture*. London: John Wiley and Sons.

Pallasmaa, J. 2009. *The Thinking Hand: Existential and Embodied Wisdom in Architecture*. London: John Wiley and Sons.

Semper, G. 1989. *The Four Elements of Architecture*. Cambridge: Cambridge University Press.

Studio 216. 2011. Culture of craft - The Value of Design series. <http://www.archdaily.com/190098/video-culture-of-craft-aia-committee-on-design/> [Accessed: 9 December 2011].

Sudjic, D. & Chipperfield, D. 2010. *Form Matters*. London: Thames and Hudson.

Unknown. 1910. *The Union Buildings and their architect*. Pretoria: State of South Africa.

Zumthor, P. 2006. *Atmospheres: Architectural Environments - Surrounding Objects*. Basel: Birkhäuser.

Zumthor, P. 2006. *Thinking Architecture*. Basel: Birkhauser.

Zumthor.Tumblr. 2012. Peter Zumthor. <http://zumthor.tumblr.com/archive> [12 April 2012].