



## Article

# Optimizing Conduit Hydropower Potential by Determining Pareto-Optimal Trade-Off Curve

Marco van Dijk <sup>1,\*</sup>, Stefanus Johannes van Vuuren <sup>1</sup>, Giovanna Cavazzini <sup>2</sup>, Chantel Monica Niebuhr <sup>1</sup>  
and Alberto Santolin <sup>3</sup>

<sup>1</sup> Department of Civil Engineering, University of Pretoria, Lynnwood Road, Hatfield, Pretoria 0002, South Africa; fanie.van.vuuren51@gmail.com (S.J.v.V.); chantel.niebuhr@up.ac.za (C.M.N.)

<sup>2</sup> Department of Industrial Engineering, University of Padova, Via Venezia 1, 35131 Padova, Italy; giovanna.cavazzini@unipd.it

<sup>3</sup> 45 Engineering s.r.l., Corte delle Filande 16, 36075 Montecchio Maggiore, Italy; alberto.santolin@45-eng.com

\* Correspondence: marco.vandijk@up.ac.za

**Abstract:** In numerous locations of bulk water supply/distribution systems, energy is dissipated by pressure-reducing devices, whereas it could be recovered by means of turbines or pumps as turbines. These pipe systems, owned and operated by municipalities, water utilities, large water-consuming industries, and mines, could be used as a source of renewable sustainable energy. However, the exploitation of these systems presents several issues related to the complexity of the operational optimization of the hydropower generation facilities and to the potential negative impact on the reliability of the system itself. We have developed a novel procedure to optimize the energy generation in such a conduit system by assessing the interrelationship of storage volumes, demand patterns, operating cycles, and electricity tariff structures. The procedure is a multi-objective genetic algorithm designed to provide a solution to maximize electricity generation and thus revenue and to minimize the risk involved in supplying the demand. A Pareto-optimal trade-off curve is set up, indicating the potential benefit (revenue) versus the reliability index (supply security). The results indicate that a Pareto-optimal trade-off curve was generated from which a solution could be selected which would improve the weekly revenue by up to 7.5%, while still providing a reliable water supply system.

**Keywords:** conduit hydropower; energy recovery; genetic algorithm; optimized energy generation; pareto optimality; renewable energy



**Citation:** van Dijk, M.; van Vuuren, S.J.; Cavazzini, G.; Niebuhr, C.M.; Santolin, A. Optimizing Conduit Hydropower Potential by Determining Pareto-Optimal Trade-Off Curve. *Sustainability* **2022**, *14*, 7876. <https://doi.org/10.3390/su14137876>

Academic Editor:  
Enrique Rosales-Asensio

Received: 13 April 2022

Accepted: 22 June 2022

Published: 28 June 2022

**Publisher's Note:** MDPI stays neutral with regard to jurisdictional claims in published maps and institutional affiliations.



**Copyright:** © 2022 by the authors. Licensee MDPI, Basel, Switzerland. This article is an open access article distributed under the terms and conditions of the Creative Commons Attribution (CC BY) license (<https://creativecommons.org/licenses/by/4.0/>).

## 1. Introduction

The increasing demand for energy is primarily driven by population growth, industrial developments, the electrification of transport and heat and air conditioning, and growing demand for digitally connected devices. This demand needs to be met in order to support uninterrupted economic growth. However, the climate energy transition requires this to be undertaken in a sustainable way, by developing new low-carbon generating capacity or by implementing renewable energy technologies such as wind, solar, biomass, or hydropower (conventional and unconventional) technologies. Energy efficiency, the optimization of existing systems, and the pursuit of new approaches in energy generation are all receiving immense attention.

South Africa (SA) has unfortunately faced capacity constraints in recent years, resulting in electricity shortages and so called “load shedding”, which refers to an action undertaken to reduce the load and manage the electricity demand as the demand outstripped the supply. SA is a water-scarce country and therefore it is recognized that it does not have the greatest hydropower potential, especially when compared with other countries in Africa. Due to this water scarcity, large quantities of raw and potable water are conveyed through conduits over long distances and elevations. These water delivery systems have to be operated effectively to ensure a sustainable and reliable water supply. In cases

where conduit hydropower is added into the system, the operating of the system has to be carefully managed. Municipalities, water utilities, large water-consuming industries, and mines could consider the development of the opportunities which exist regarding small-scale hydropower installations in their water infrastructure. Most of these water supply/distribution systems could be equipped with energy recovery devices (ERDs), such as turbines or pumps-as-turbines, supplementing and reducing the requirements for conventional energy-dissipating devices such as pressure-reducing valves [1]. The generated hydroelectric energy may be used onsite, supplied to the national electricity grid, or fed into an isolated mini-grid.

Several studies have been published on energy recovery from the water supply and distribution networks, and Table 1 provides an overview of the literature, which is also well summarized in a review by Pérez-Sánchez et al. [2]. As can be seen in Table 1, these studies focus on various aspects of energy recovery; ranging from turbine selection; the optimization of efficiency; the development of new turbines; simulation and modeling of turbines up to the evaluation of environmental, economic and social benefits; as well as policies which govern their implementation.

According to Van Dijk et al. [3], there are basically six areas where energy can be generated in a bulk water supply and distribution system, as shown in Figure 1.

1. Dam releases, which feed into the bulk supply line/transfer scheme;
2. Inline conduit hydropower, where excess pressure is available along the pipeline route;
3. Break pressure tanks along the pipeline route;
4. Water-treatment works (raw water), where excess energy needs to be dissipated before entering the treatment facility;
5. Potable water at reservoirs (pressure-reducing valves (PRVs)), where excess energy is dissipated before entering the distribution/service reservoir;
6. Potable water at pressure-reducing stations (PRSs) in the supply network or at specific locations in the network.

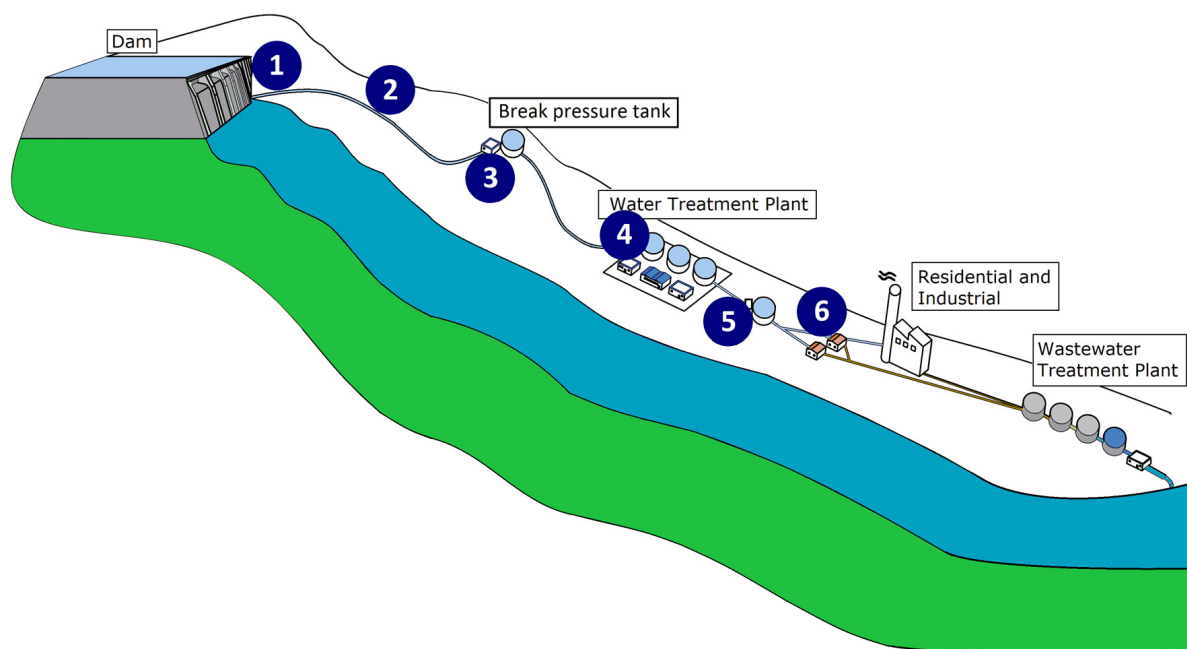

**Figure 1.** Locations with energy generation potential (adapted from [3]).

Many studies have demonstrated the economic and environmental benefits of energy recovery systems implemented in water supply and distribution systems [4–9]. Their analyses have shown that the benefits of selling energy and generating revenue and/or of reducing operational costs allowed the achievement of acceptable payback periods [4,10,11].

These benefits can be even more significant in countries such as South Africa, which has been facing high tariff hikes since 2008 (with some years having increases greater than 20%).

**Table 1.** Researched topics related to energy recovery from water supply and distribution networks (adapted from [2]).

Researched Topic	References
Reduction of leaks, decreasing the pressure in water supply systems and increasing the efficiency	[12–20]
Proposal to use adapted machines (PATs and tubular propeller) in water supply systems to reduce the pressure	[21–24]
Description and operation of a PAT with a review of available technologies	[25–30]
Performance and modeling of a PAT	[26,31–38]
Installation of energy recovery systems or devices in water supply networks	[1,4,9,11,15,17,39–51]
Implementation of simulations to determine the theoretical recovered energy in water supply and irrigation systems	[52–62]
Design of variable operating strategies to maximize the recovered energy	[12,14,40,63]
Economic cost of implementing recovery systems in water supply and irrigation networks	[10,12,25,64,65]
Environmental advantages	[22,66,67]
Policies and analyses to help development	[31,68–73]
Pilot plants built in water supply networks	[4,6–8,50,51]
Optimization to maximize recovered energy in water supply systems	[58,62,74–77]

In the literature it has been widely recognized that the problem of the introduction of an ERD in a pipe system has to be faced by applying optimization strategies with different purposes, for example, revenue maximization. However, each proposed optimization strategy is characterized by simplifications, affecting the accuracy of the results. For example, the real operating conditions of a water distribution network are only partially considered in the assumptions of mean demand value or modulation curves. Moreover, several studies did not model the real turbine behaviour, neglecting the influence of the system's operating conditions on the turbine efficiency and operating range.

These limits were clearly highlighted in a review by Pérez-Sánchez et al. [2], where the need to implement, as part of the optimization procedure, the real operating conditions for both the system and the energy recovery devices is identified as the key challenge in the development of optimization methods. Similar conclusions were also drawn by Delparque et al. [78], who indicated that simulation tools must be expanded to include the option to simulate a turbine as part of the water distribution model. According to Pérez-Sánchez et al. [2], different case studies have been evaluated using specific software (e.g., EPANET and WaterGEMS), which have been combined with optimization methodologies to maximize the recovered energy.

The challenges involved in optimizing water distribution systems in real operating conditions are mainly due to the nature of the variables (both real and discrete), as well as the size of the solution space. Moreover, depending on the optimization goals, the optimization variables are different, and a number of boundaries and constraints have to be considered [79]. For example, a major problem for water supply authorities is to select those components in a network that should be changed, increased, or replaced to ensure a sustainable service for consumers at the lowest cost. Water supply authorities also face other problems, such as the network design itself, network calibration, operation, and

reliability. Table 2 reports a non-exhaustive summary of the possible optimization fields with the related goals, variables, and constraints.

**Table 2.** Types of optimization for water supply/distribution systems (adapted [79]).

Optimization Type	Objective	Possible Variables	Main Constraints
Design	Minimize cost	Pipe layout; pipe diameters; pipe rehabilitation	Min level of service; available diameters; rehabilitation options; available budget; LCC
Operation	Minimize operational cost	Pump controls; reservoir levels; sources and capacity	Min level of service; number of pump switches; source capacity; pump capacity
Calibration	Minimize difference between model and observed values	Valve settings; pipe roughness, diameter; leakage; demands	System layout; available data
Level-of-service	Maximize level of service, e.g., pressure, water quality or reliability	All of the above	System configuration; budget
Monitoring system design	Minimize cost of monitoring system	Number and position of monitoring points	System configuration; budget
Conduit hydropower	Maximize energy generation potential	Turbine selection; reservoir levels; sources and capacity; operating scenarios	Acceptable operating risk levels; hydraulic operating range; pressure requirements; source capacity; turbine capacity; LCC

There are numerous recent studies which highlight the importance of the application of multi-objective optimization algorithms in the energy engineering field [80–85]. A multi-objective optimization is a reliable approach as in these types of problems, the intention is to obtain a collection of solutions which satisfy the objective functions to various degrees, with which a Pareto frontier can be formed, presenting the probable answers through the function zone [83].

## 2. The Optimization Problem in Water Distribution/Supply Networks

Water supply and distribution systems consist of a complex network of interconnected pipes, service reservoirs, and pumps, and nowadays also turbines, which deliver water from the treatment plants to the consumers. Frijns et al. [75] indicates that there is a significant potential for energy recovery through the use of micro-hydropower installations in water supply systems, but to exploit this potential and to balance this hydro energy with the optimal hydraulic performance and water supply service, multi-objective management tools are needed. First, the distribution of water through the supply and distribution system is governed by complex, non-linear, non-convex, and discontinuous hydraulic equations [86]. Adding to this complex network of components, the hydropower plant from which the maximum benefit needs to be extracted requires a methodical procedure to evaluate the interrelationship between storage volumes, supply/demand patterns, turbine selection, operational flexibility, and the reliability of supply. Finally, in the formulation of the optimization algorithm, natural or logical constraints need to be identified and considered.

The identification of these constraints is site-specific and, in some cases, requires:

- A dynamic analysis of the pipe system to determine safe operational ranges (maximum velocity; pressure);
- A hydraulic assessment of the pipe system (pressure and flow measurements from which the pipe roughness can be back calculated);
- Definition of the acceptable reservoir levels (which could be based on the proposed location of the hydropower plant in relation to other storage facilities); and

- Analyses of the water source to determine the historical supply characteristics and physical constraints.

Numerous optimization algorithms have been described in the power engineering literature. Most of these approaches are heuristic and rely on innovative search techniques drawn from biological and physical processes [87]. The proposed genetic algorithm (GA) used in this paper falls in the evolutionary algorithm class, where rules and logic are applied, resulting in the search space being reduced and allowing for the solution of challenging optimization problems.

GAs have been successfully applied as search techniques for numerous civil engineering problems, such as in structural design optimization, construction scheduling, transportation scheduling, water distribution network evaluation, pump scheduling, network calibration, hydrological runoff predictions, and resource utilization. A GA is a search technique inspired by Charles Darwin's theory of natural evolution and according to Michalewicz [88], this can basically be described as reflecting the process of natural selection where the fittest or strongest individuals are selected for reproduction to produce the offspring of the next generation.

GAs imitate nature's optimization technique of evolution, i.e., have biological processes at their inspiration, and are based on:

- Selection and thus survival and reproduction of the fittest members of the population;
- The maintenance of a population to have diverse members at all times;
- The inheritance of genetic information from parents i.e., combining fit solutions; and
- The occasional mutation of genes, resulting in incremental alteration of the present solution.

A GA evolves and finds optimal solutions by sampling from the total solution space where the best of these solutions are combined, using the genetic operators of crossover and mutation, to form new solutions. The identification of these best solutions is performed based on a set of objective functions. This process continues until some termination condition (convergence criteria and/or a number of maximum iterations) is fulfilled.

The present study was based on a real coded genetic algorithm (RCGA) in which the population was ranked based on their fitness values (for example, generated electricity, including penalty constraints) and the elitist status, i.e., the higher the fitness values the higher the probability of being selected for reproduction.

The RCGA was applied to an optimization problem with the goal of maximizing the net annual income from hydropower generation in a water supply system within acceptable reliability regimes of operation. It is clear that the problem requires a multi-objective optimization procedure, since both the maximization of the electricity generation (i.e., of the revenue) and the minimization of the risk of non-supply (i.e., the maximization of the system reliability) have to be searched.

To develop an optimization procedure, it is first necessary to define the object of the optimization and then to express the optimization goals in terms of mathematical objective functions.

In this paper the optimization object, conduit hydropower plants (CHPs) inserted in the water distribution/supply networks, were targeted. Figure 2 shows a general scheme of the targeted system, which is similar to that proposed by Cheng et al. [89].

The first goal of the optimization procedure was to maximize the generation output from a CHP over a defined operating period according to the typical historical supply and demand patterns. So, the first objective function  $F_j$  to maximize the revenue deriving from the generation of the  $j$ -th CHP was formulated as follows, in Equation (1):

$$F_j = \max \sum_{t=1}^T (\rho g H_{t,j} Q_{h,t,j} \eta_{t,j} C_{t,j}) \quad (1)$$

where:

- $T$  is the operating period (for example, one week of operation)

- $\rho$  is the water density ( $\text{kg}/\text{m}^3$ ) and  $g$  is the gravitational acceleration ( $\text{m}/\text{s}^2$ )
- $H_{t,j}$  is the average head of the  $j$ -th CHP within time period  $t$  (m)
- $Q_{h,t,j}$  is the average water discharge of the  $j$ -th CHP within time period  $t$  ( $\text{m}^3/\text{s}$ )
- $\eta_{t,j}$  is the average hydropower plant efficiency of the  $j$ -th CHP within time period  $t$  (%)
- $C_{t,j}$  is the energy tariff within time period  $t$  (unit cost/kW)

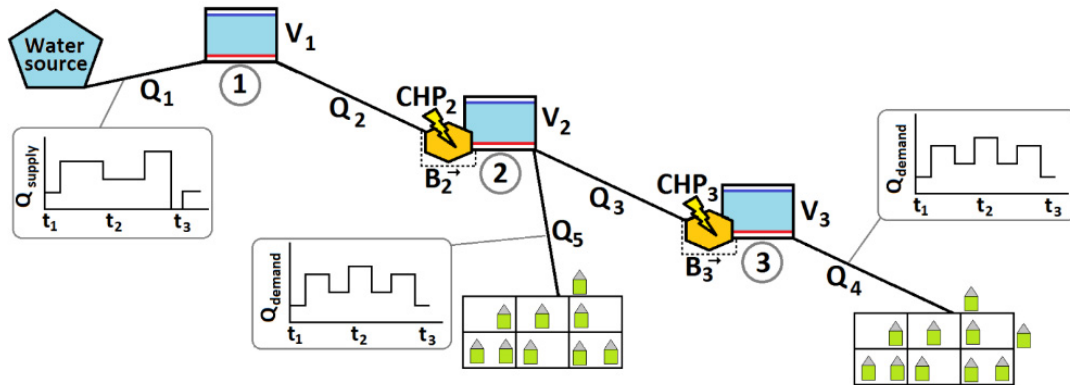

Figure 2. Layout of CHP series connected system.

This objective function aims to maximize the revenue that can be extracted from the water supply system by evaluating CHPs at specific locations.

This first objective function is subjected to the following constraints:

- Reservoir storage limits (Equation (2))

$$V_{t,j,min} \leq V_{t,j} \leq V_{t,j,max} \quad (2)$$

where  $V_{t,j}$  is the volume of the reservoir storage at the beginning of the period  $t$  ( $\text{m}^3$ ) and  $V_{t,j,min}$  and  $V_{t,j,max}$  are the minimum and maximum values allowed, respectively.

- Pipe system discharge limits (Equation (3))

$$Q_{t,j,min} \leq Q_{t,j} \leq Q_{t,j,max} \quad (3)$$

where  $Q_{t,j,min}$  and  $Q_{t,j,max}$  are the minimum and maximum values of the water discharge capacity of pipe system ( $\text{m}^3/\text{s}$ ).

- Hydropower station power generation limits (Equation (4))

$$N_{j,min} \leq \rho g H_{t,j} Q_{h,t,j} \eta_{t,j} \leq N_{j,max} \quad (4)$$

where  $N_{j,min}$  is the minimum hydropower power generation and  $N_{j,max}$  is the maximum installed capacity (kW).

- Hydropower station discharge limits (Equation (5))

$$Q_{h,t,j,min} + Q_{b,t,j,min} \leq Q_{t,j} \leq Q_{h,t,j,max} + Q_{b,t,j,max} \quad (5)$$

where  $Q_{h,t,j,min}$  and  $Q_{h,t,j,max}$  are the minimum and maximum water discharge capacity of the hydropower plant ( $\text{m}^3/\text{s}$ ), whereas  $Q_{b,t,j,min}$  and  $Q_{b,t,j,max}$  are the minimum and maximum water discharge capacity of the bypass ( $\text{m}^3/\text{s}$ ).

- Water balance equation (Equation (6))

$$V_{t+1,j} = V_{t,j} + (Q_{h,t,j} + Q_{b,t,j}) \Delta t \quad (6)$$

where  $\Delta t$  is the time step and  $V_{t+1,j}$  is the volume of the reservoir storage at the time  $t + 1$ .



These constraints are considered in the first objective function by penalizing the final score of those solutions violating one or more constraints utilizing penalties.

The subscript “ $j$ ” refers to each hydropower plant in the interconnected system.

The second goal of the optimization procedure is to minimize the risk of non-supply, i.e., the operating conditions which could compromise the integrity of the supply system. This can also be defined as maximizing the reliability of the supply system.

In general, bulk water supply systems are designed based on deterministic guidelines. Many of these systems have some redundancy since the system capacity was designed to supply the ultimate demand at the end of the design life. A conservative approach is usually adopted during the design phase due to the uncertainties of the pipe roughness decay parameter and future demands. Due to this conservative design approach, many bulk supply systems have excess capacity in the pipeline or excess storage available, which allows for flexibility in the operation of the water supply system aimed at favoring the energy recovery. However, despite this operational flexibility, the operating scenario imposed by the energy recovery technologies can give rise to hazardous events, negatively affecting the reliability of the system. In the optimization procedure, this reliability of the system stemming from a certain operation should be transposed into a mathematical objective function.

According to Chang and Van Zyl [90], various authors have analyzed the reliability of bulk water supply systems using frequency durations, Markov chains, and Monte Carlo approaches.

The first step is to identify the possible hazardous events by means of a risk analysis, the main phases of which were defined by Hokstad, et al. [91]:

- Define the scope/analysis objective;
- Provide a system description;
- Identify hazards and hazardous events; and
- Assess the risk (evaluating probabilities and consequences).

In this specific case, the objective of the analysis was to identify the risks related to the incorporation of the CHPs in a water supply system. Once identified, these risks have to be estimated, adopting one of the methods available in the literature. In this case, a coarse risk analysis (CRA) based on a risk matrix was utilized. This simplified analysis method was chosen since it was considered suitable for most water utilities.

The risk matrix allows one to score the hazardous events depending on their likelihood and on the severity of their consequences (Table 3). Depending on the combination of likelihood and severity, a risk score is assigned to each hazardous event. This score is based on where the risk acceptance criterion is defined and, in some cases, how certain risks above the acceptance criteria should be treated [91].

**Table 3.** Example of risk matrix [91].

Likelihood	Severity of Consequences				
	Insignificant	Minor	Moderate	Major	Catastrophic
Almost certain	5	6	7	8	9
Likely	4	5	6	7	8
Moderately likely	3	4	5	6	7
Unlikely	2	3	4	5	6
Rare	1	2	3	4	5

Note: A hazardous event with a low score (for example 1) would indicate the combination of likelihood and severity is low with higher scores indicating higher likelihood of occurring and/or increase in severity of consequences.

In this case, hazardous events refer to operational activities due to the CHP introduction in the system, whereas the main negative consequence is related to the non-delivery

of water. To properly score the risk, the average unavailability of supply was not considered sufficient and thus both the frequency and duration of interruptions were taken into account. Some examples of risk quantification extents are:

- Probability (fraction of time) that the supply cannot be met, due to a low reservoir level, for instance.
- Frequency of events resulting in failure to supply water due to, for instance, pipe bursts.
- Volume of water shortage due to demand exceeding supply and low reservoir levels.
- Time required after a failure such as a reservoir “run-dry” for re-filling of the pipeline or reservoir.
- Potential of dynamic pressures when operating above design capacity.

Each of these risks should be assessed, as well as the probability of the risks occurring against the impacts they have on the water utilities’ main responsibility i.e., the sustainable and reliable supply of water. A major challenge involved in performing risk analyses is the lack of relevant data, for example, the pipe burst frequency. Ideally, water utilities or municipalities should design their own databases and record system failures with causes and consequences in order to define failure probabilities.

Each probability of failure and its consequences is presented as a numerical value (scoring). According to this risk analysis, a mathematical formulation to score the risk  $R_i$  for the  $i$ -th hazardous event which could have an impact on the reliability of supply is defined as in Equation (7):

$$R_i = \sum_{t=1}^T (\alpha_{t,i} \beta_{t,i} P_{t,i} I_{t,i}) \quad (7)$$

where:

- $P_{t,i}$  is the risk probability [%]
- $I_{t,i}$  is the risk impact
- $\alpha_{t,i} = f(P_{t,i} I_{t,i})$  is a coefficient to incorporate variation in the operating risk at reservoirs (risk quantification), which ranges from 0 to 100. Indeed, the consequence of operating a reservoir at a certain water level is not static and is dependent on the time of day/demand pattern.
- $\beta_{t,i} = f(P_{t,i} I_{t,i})$  is a coefficient to incorporate variation in operating risk for the pipe system (risk quantification), which ranges from 0 to 100. Indeed, the consequence of operating the pipeline in a specific manner is not inert.

Thus, the second objective function of the optimization procedure was formulated in terms of a reliability index ( $RI$ ) expressed as a percentage, and it was defined as one minus the risk value, as shown in Equation (8):

$$RI = 100 - R_i \quad (8)$$

### 3. Multi-Objective Optimization Procedure

The optimization problem introduced in the previous section is multi-objective since two different goals are defined: to maximize the energy generation (Equation (1)) and to ensure the reliability of supply (Equation (8)).

To formulate this multi-objective problem in an optimization procedure, three approaches were available. The first approach converts the problem into a single-objective optimization problem. This is achieved using adjustments, such as a weighted sum of objectives, or an  $\varepsilon$ -constraint method. The weighted sum approach gives a certain weight to the different objectives and then incorporates all these weights to form a single-objective function that can be solved by means of single-objective optimization. This method has limitations because it is extremely difficult to qualify the weights assigned to each of the different objectives.

Another approach is termed “the constraint method”, in which just one objective function is chosen as the optimization goal, whereas the other objective functions are



treated as constraints with a limited range for their values. The optimal solution depends on the selection of the pre-defined constraint limits.

The third approach considers all the objectives simultaneously, setting up a Pareto frontier, representing the optimal trade-off curve between them.

In this study, as both objectives are to some extent contradictory, it is not possible to improve one objective without sacrificing the other [92]. In this study the third approach was implemented in the optimization procedure, summarized in a flow chart in Figure 3. The result of the optimization procedure is hence a Pareto-optimal trade-off curve between the generated income and the potential impact on the reliability of the system.

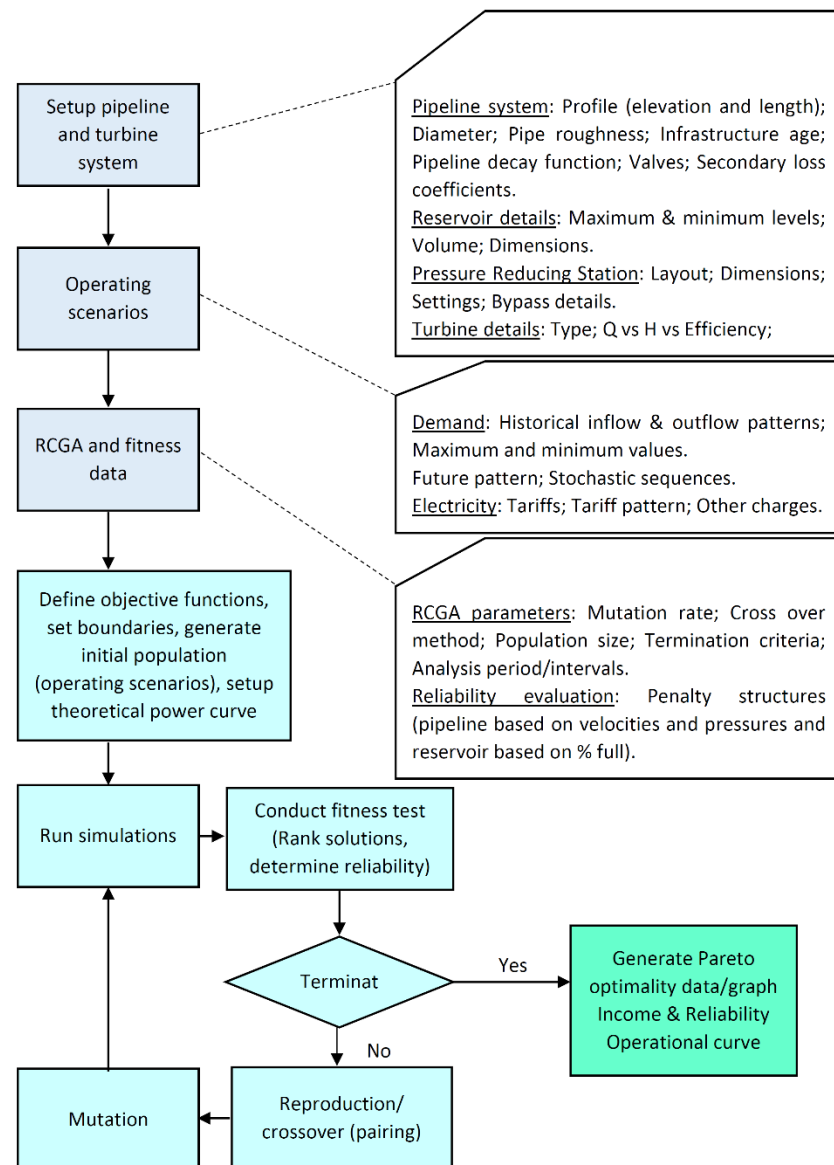

**Figure 3.** Flow chart of the conduit hydropower operational optimization model.

In the first phase of the optimization procedure (gray blocks in Figure 3), the pipeline system is modeled in the EPANET environment [93], considering the boundary conditions and the constraints of all the system components (pipes, pressure valves, reservoirs, turbine, etc.). The operating scenario is also defined by including demand profiles, future patterns, and electricity remuneration schemes.

Then, the main parameters of the optimization algorithm RCGA are set up and the optimization procedure starts with the generation of the initial population (light blue boxes in Figure 3). Each individual of the population represents a possible solution of the problem,

i.e., a possible combination of operating conditions of the pipeline system. With the flow changing, the system characteristics impact the available head for hydropower generation and therefore its performance. The fitness of the solution is determined by performing a simulation of the hydraulic behavior of the modeled pipe network and the values of the objective functions (Equations (1) and (8)) are determined by considering both the turbine production in the proposed operating conditions and the reliability of the corresponding system's operation.

To manage the interactions during the optimization procedure between the optimization algorithm RCGA, the system simulation software (EPANET), and the fitness evaluator, a conduit hydropower optimization tool (CHOT) was developed (Figure 4). The tool links the optimization procedure with EPANET and proper modules evaluating both the turbine performance in the pipe system and the reliability of the proposed system's operation.

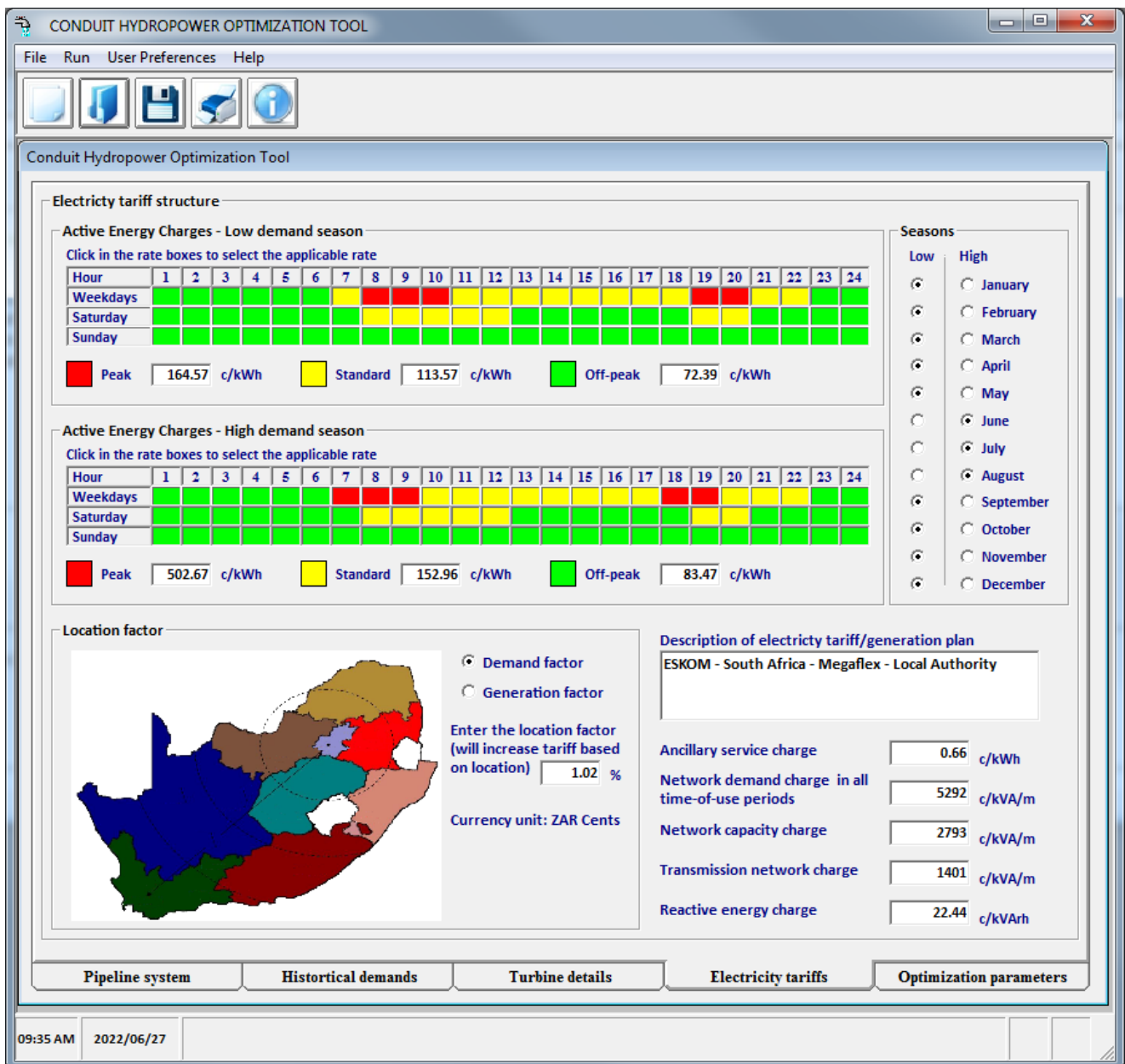
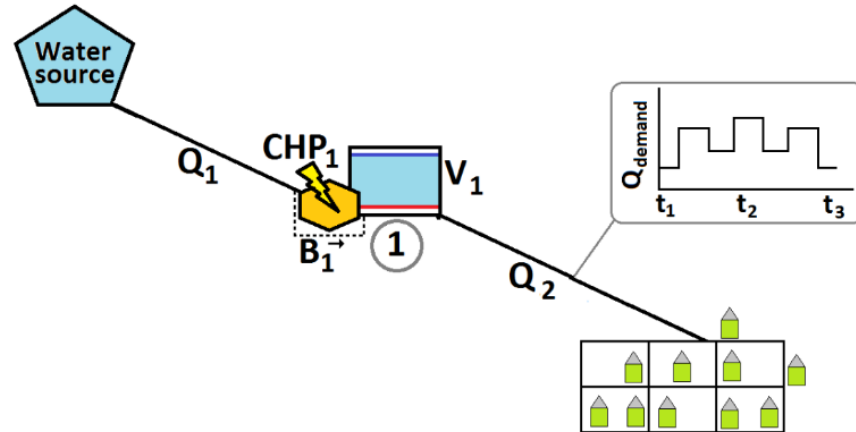

Figure 4. Example of definition of an electricity tariff structure used to determine revenue (Megaflex) for every time period.

#### 4. The Case Study

This multi-objective algorithm procedure, described in the two previous sections, was tested on a simplified pipeline system which contained a single potential installation for conduit hydropower generation (Figure 5).



**Figure 5.** Simplified pipeline system.

The scheme shown in Figure 5 depicts a simplified pipe system of 8 km in length, with pipe diameters of 400 mm, a static height difference between water source, and a full reservoir supply level of 100 m and a pipe roughness of 0.1 mm. A 95 kW Francis type turbine installation was selected with varying efficiencies based on the operating parameters. The electricity tariffs were based on South African Megaflex tariffs for local authorities in the low-demand season (Figure 4).

As regards the operating period, a full week of operation was considered and the CHP generation was evaluated with a time period of 15 min.

The boundaries were set, which included the reservoir storage limits, the pipe system discharge limits, the hydropower station power generation limits, the hydropower station discharge limits, and the minimum and maximum water discharge capacity of the bypass. A typical residential 15 min demand pattern with a morning and afternoon peak was assumed.

To evaluate the reliability of the operating scenarios, the potential hazardous events were identified and for each of these a risk rating scale was defined. For example, the risk score for the various reservoir levels was arbitrarily set at 20, 15, 10, 5, 2, and 0 for the cases where the reservoir volumes were below 10%, between 10% and 30%, between 30% and 50%, between 50% and 70%, between 70% and 85%, and above 85%, respectively. This implies that the risk was low if the reservoir level was above 85% for a specific time period and hence the corresponding reliability of supply would be high. A similar risk rating scale was set up for the velocity in the pipeline, in which low values were preferred to high values.

The system would also be penalized if the reservoir level was significantly different from the start of the week as this could influence the reliability or the generation potential for the next week. These penalties were used to define the reliability index (RI) presented above (Equation (8)).

With regards to the optimization algorithm, the following parameters were set: split at a randomly determined single crossover point, a mutation rate of 2%, iterations set to 100, and a population size of 100.

#### 5. Results and Discussion

The system was analyzed for three scenarios characterized by different values of the initial start reservoir level at the beginning of the week (60%, 70%, or 80% of the full supply level (FSL)).

Each scenario was analyzed 100 times, consisting of 100 solutions in the RCGA. The improvement in the optimization of Objective 1 (maximizing revenue) through each iterative step of the RCGA iterations is depicted in Figure 6. The best revenues that were achieved using the initial population for scenarios 1, 2, and 3 were ZAR 13,037 (EUR 745), ZAR 12,742 (EUR 728), and ZAR 12,849 (EUR 734), respectively. As indicated in Figure 6, the potential revenue that could be generated improved through the optimization process until reaching maximum values of ZAR 15,014 (EUR 858), ZAR 14,432 (EUR 825), and ZAR 14,679 (EUR 839) for Scenarios 1, 2, and 3 respectively. Although the maximum revenue was determined, these solutions did not necessarily have the required reliability index (RI) values.

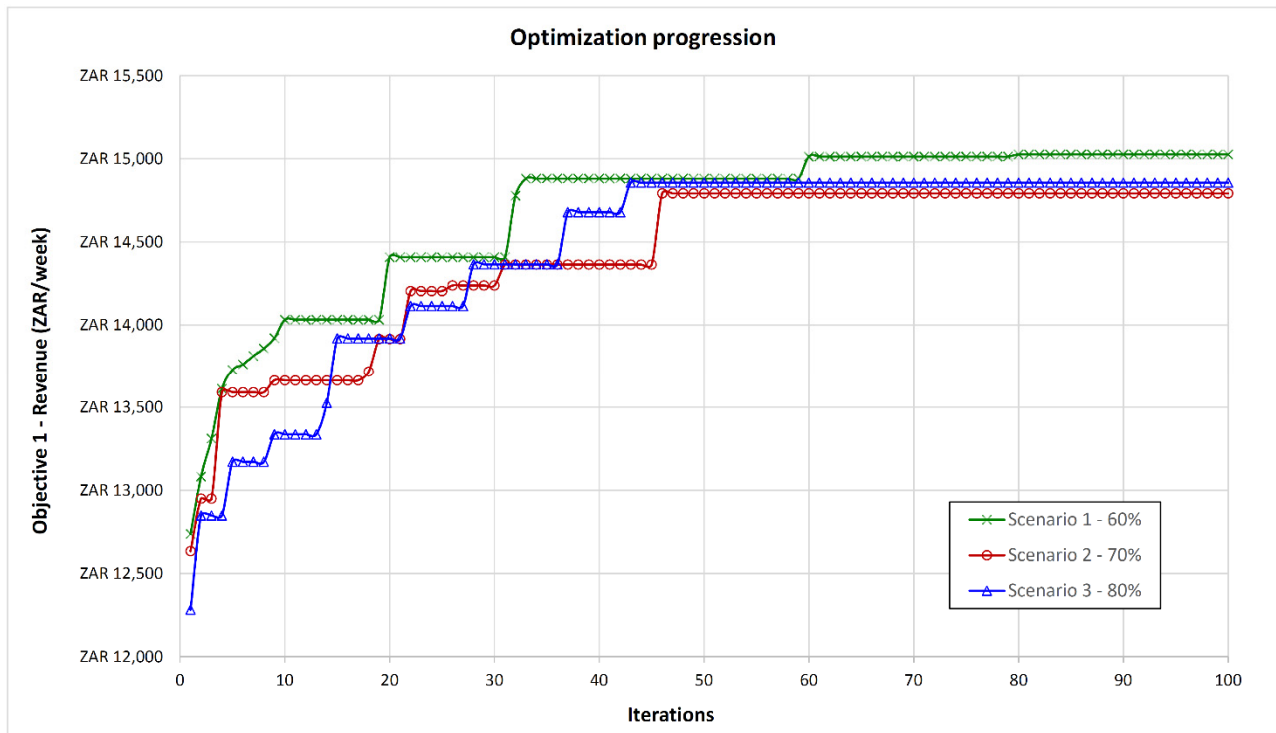

Figure 6. GA iterations (optimization of Objective 1—maximizing revenue).

Figure 7 shows the results of the three optimization procedures (scenarios) carried out with the CHOT tool. Each point in the graph represents a solution which obtained a certain value of revenue (objective function 1—Equation (1)) and reliability index (objective function 2—Equation (8)). For this simplified case study, the objective was to reach a minimum generating revenue of above ZAR 14,000 (EUR 800) and having a reliability index RI above 70% (dotted lines in Figure 7). The reason for setting the minimum generate revenue objective to ZAR 14,000 (EUR 800) was that this would be the minimum weekly revenue needed for the development of a feasible hydropower plant with a payback period of between 5 and 6 years in South Africa. The reason for setting the RI at 70% was to have a high probability that there would be sufficient storage volume available to provide for any emergency situation. Numerous viable solutions were found, as depicted in Figure 7, and a combination of generated revenue and RI can be selected from these. The solution provides the operational profile that would result in the determined revenue while ensuring a reliability of supply.

For each scenario, the CHOT also identified the resulting set of Pareto optimal fronts (lines in Figure 7), indicating the potential maximum revenue and the reliability of being able to supply the demand placed on the system.

The analyses showed that for a system which started at an initial reservoir level of only 60% of FSL, there were only a few solutions with a reliability index value above 70%, although these solutions did not generate a revenue above ZAR 14,000 (EUR 800). Starting

with an initially higher FSL resulted in the overall system having a higher reliability to supply the demand and not drawing down the water level in the reservoir too far.

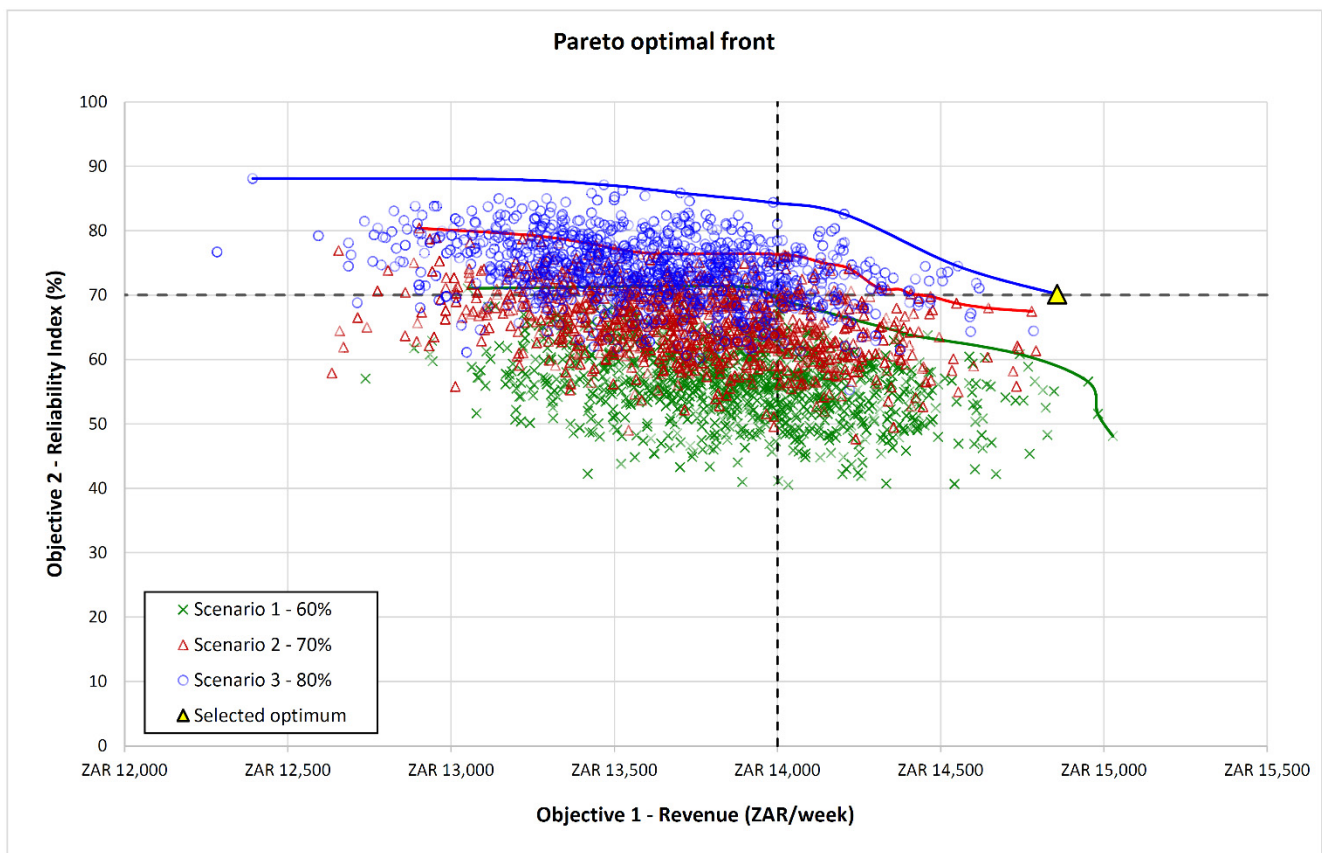

**Figure 7.** Pareto optimal front (for 3 different initial reservoir volumes, Scenarios 1, 2, and 3).

Looking at the more favorable scenarios (70% and 80% of FSL), the results of the multi-objective optimization clearly provided more than one option of operations and the final choice would depend on the operator's goals and needs.

As an example, if the objective was to generate the highest possible revenue during the week while still operating with an RI above 70% and the initial reservoir level was at 80% of the FSL, then the optimum was as indicated in Figure 7. The optimum in scenario 3 would generate ZAR 14,856 (EUR 849) and the RI was 70.1%.

The selected operating flow pattern scenario which would produce this optimum result is shown in Figure 8. The variation in water levels in the reservoir for this selected optimum can be seen, and although there was an instance where this dropped to below 70%, it recovered and by the end of the week it was almost at its starting level at the beginning of the week (80%), ending at 79.4%.

The inflow ( $Q_1$  in Figure 5) is strictly related to the CHP generation and it is clear that the resulting flow pattern is driven by the outflow from the reservoir ( $Q_2$  in Figure 5), which is typical for a residential network, due to the reservoir volume constraints (Figure 7). An interesting observation is that when the RI is set very low, the operating flow pattern started to mimic the tariff pattern, i.e., generating more power during the higher tariff periods. The reason for this is that the constraints the reservoir and pipe system placed on the system (incorporated in the RI) were low and thus the system had more flexibility to operate in a manner that generated more power and subsequently revenue.

The outflow, as depicted in Figure 8, was for a typical residential network and the inflow was the ERD controlling the operating flows, resulting in this specific flow pattern scenario producing this specific solution on the Pareto optimality curve. This further



demonstrates the capability of the optimization procedure in handling the constraints and the risks of a hazardous event affecting the system's reliability.

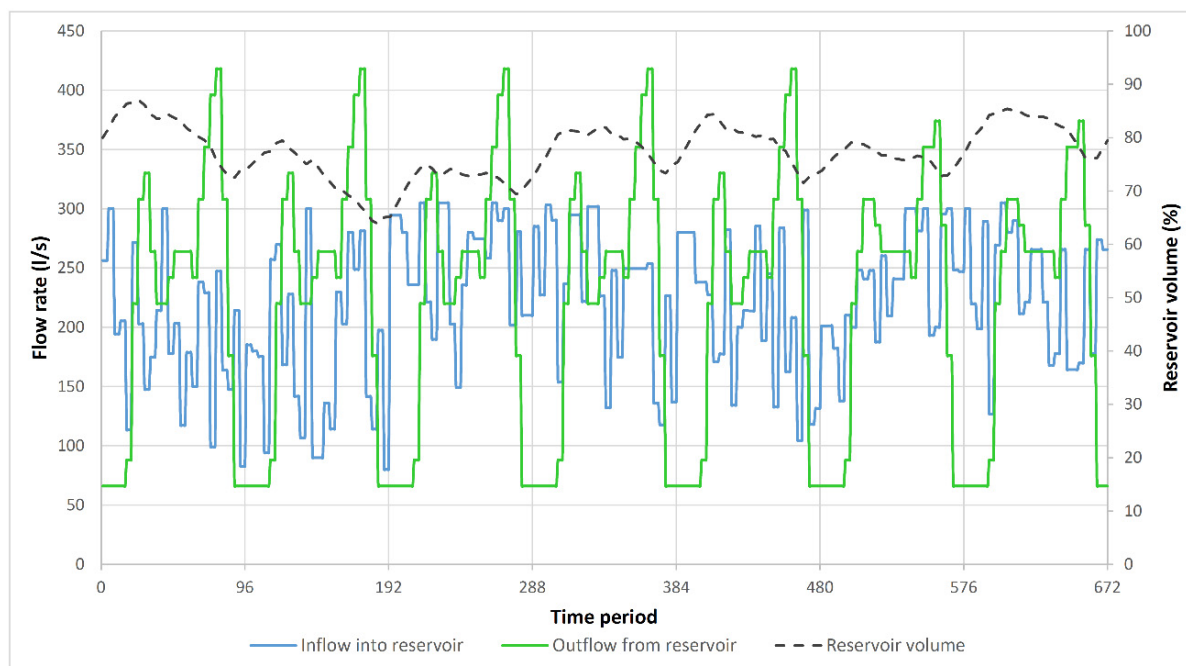

**Figure 8.** Flow and reservoir levels for the selected Pareto optimum.

The resulting power generation was linked to the flow pattern and the available pressure head at the site, as well as the turbine efficiency at this specific operating point. The flow patterns were changed to find a favorable flow pattern of supplying water to the reservoir which would meet the demand placed on the reservoir and generate the maximum revenue in a week. Although the system was analyzed every 15 min (simulation time step) to obtain a better accuracy in the change in water levels in the reservoir, the suggested changes in flow were only implemented on an hourly basis (i.e., flow was kept constant for at least 1 h). This is a theoretically-based analysis and could still be further smoothed, for instance, by only changing the flow every couple of hours, especially in cases where the storage is large. The generated power varied from 32.3 to 95.3 kW, with an average value of 75.1 kW (Figure 9). The analyses indicated that for the selected optimum solution, the average generation was 73.6, 78.3, and 79.0 kW during the off-peak, standard, and peak tariff periods, respectively. This indicates that the optimization process identified that the revenue was maximized when the generation was maximized during the high-value electricity tariff periods. The maximum generation occurred when flow was around 200 L/s, slightly less than the average flow of 220 L/s, which yielded the optimum output.

The generated revenue was linked to the generated power, but it also depended on the applicable time-of-use tariff for that analysis period, according to the selected remuneration scheme (South African Megaflex tariffs for local authorities in the low-demand season). This is clearly reflected in the wide revenue variation from ZAR 6.91 (EUR 0.39) to ZAR 41.12 (EUR 2.35) per minute period over the weekly operating period. This variation was due not only to the large variations in power generation (flow-, pressure head-, and efficiency-dependent) but also to the hourly tariff variation during the day/week.

In such a context, it is clear to see the relevance of simulating the real turbine behavior in the hydropower location, depending on the prevailing operating conditions. A constant efficiency value would have affected the accuracy of the power production and would have led to under- or overestimation of the resulting revenues.



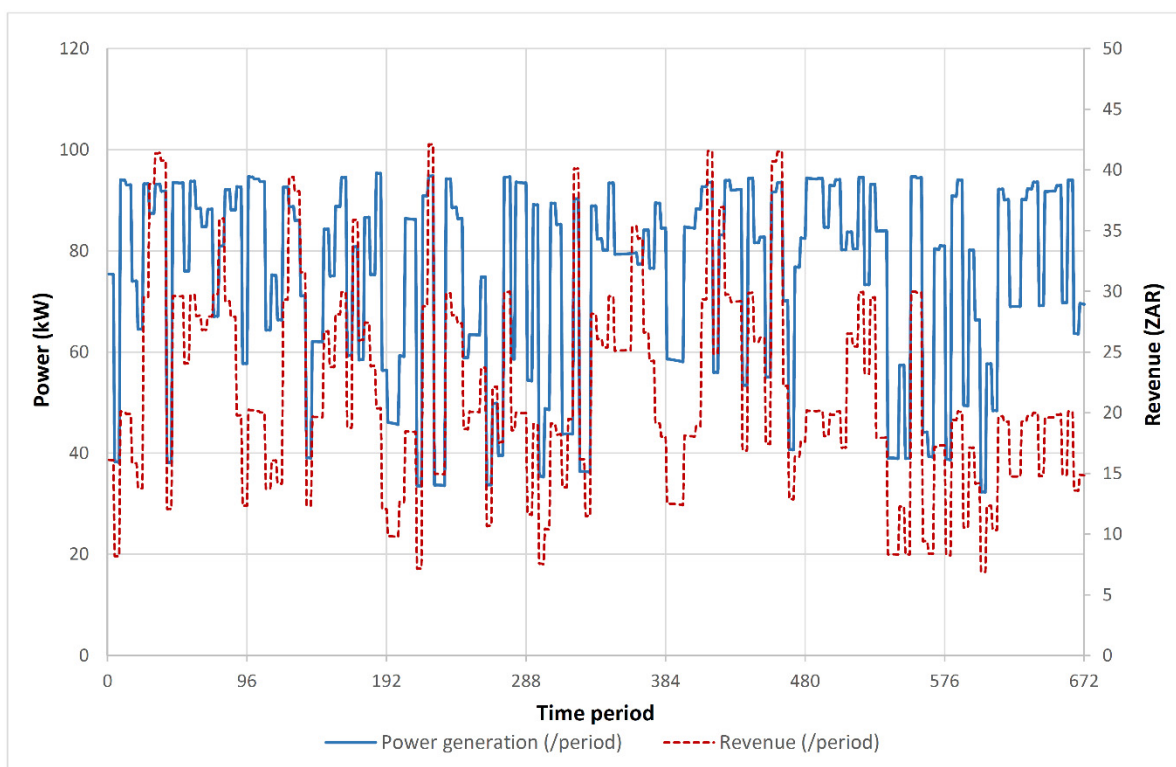

**Figure 9.** Power generation and revenue for the selected optimum (per 15 min period).

## 6. Conclusions

Globally, there is a trend towards improving energy efficiency in all sectors while at the same time increasing the use of renewable energies. This will be key in solving environmental, self-sufficiency, and cost issues, as well as meeting increasing energy demands [94].

Based on these ideals, a new optimization procedure was developed which can be applied to a water supply system to optimize income from the generation potential in the system, while still operating within predefined water supply reliability ranges.

Frijns et al. [75] highlighted the considerable potential for energy recovery through the use of ERD installations in water supply and distribution systems. To optimally develop this potential, as well as hydropower generation and the operation of the supply and distribution network within specific hydraulic performance ranges, multi-objective management tools are needed. Delplanque et al. [78] also indicated that simulation tools must be expanded to include the option to simulate a turbine as part of the water distribution model.

In this study the developed procedure was described and incorporated into a conduit hydropower optimization tool (CHOT), which has been shown to assist in the defining of the operational functioning of the system to meet the necessary objectives. Although the aim was to optimize an existing system, the tool can also assist in turbine selection by installing various options and re-optimizing the tool. The EPANET software engine used for the hydraulic analysis of the systems is a widely used, accepted, and well-tested analysis software. It is also used in various other hydraulic analysis software applications and in optimization simulations. This procedure provides designers with a tool to optimize the operational functioning of a system containing a number of CHPs. The Pareto optimal front provides a range of solutions and flow patterns, which could be implemented which would provide the maximum generation value without compromising the reliability of the system past a set criteria.

Based on the starting reservoir level and the anticipated water abstracted from the reservoir and its demand pattern, the operation of the system can be set. The developed

procedure takes into account turbine characteristics, changing turbine efficiency as the operating point changes, varying energy tariff structures, and reservoir levels.

The results indicated the potential revenue that could be generated improved through the optimization process until reaching maximum values of ZAR 15,014 (EUR 858), ZAR14 432 (EUR 825) and ZAR 14,679 (EUR 839) for Scenarios 1, 2, and 3, respectively. Comparing this with a more conventional operating pattern of higher flows during the day and lower flows during the evenings resulted in ZAR 13,947 (EUR 797), ZAR 14,108 (EUR 806) and ZAR 14,267 (EUR 815) for Scenarios 1, 2, and 3, respectively. This indicates that there is potential merit in operating the system in a flexible manner to maximize the revenue generation without compromising on the reliability of supply. The novelty in this research lies in the development of a multi-objective algorithm, used to obtain a Pareto-optimal trade-off curve between the generated income and the potential impact on system reliability. It was shown that the operational flexibility of the system could be utilized to generate maximum revenue, while still operating within acceptable and maintainable ranges.

Similarly to the research conducted by Frijns et al. [75], we found that through an integrated approach, the power generation of an ERD installed in a water supply system can be optimized, maximizing the energy generation and still ensuring the required reliable hydraulic performance of the system. This research has shown that a balance can be struck between the generation of hydroelectricity and the reliable operation of a water supply service. Further research can be conducted on applying this procedure to cascading conduit hydropower installations. Although the optimization of operating cascading water infrastructure has been researched for conventional reservoir storage or run-of-river installations [95–98], it has not been attempted for conduit hydropower installations.

**Author Contributions:** Conceptualization, M.v.D., S.J.v.V. and G.C.; methodology, M.v.D., S.J.v.V. and G.C.; software, M.v.D. and C.M.N.; validation, M.v.D. and C.M.N.; formal analysis, M.v.D. and A.S.; data curation, M.v.D., G.C., C.M.N. and A.S.; writing—original draft preparation, M.v.D. and C.M.N.; writing—review and editing, M.v.D., S.J.v.V., G.C., C.M.N. and A.S.; supervision, S.J.v.V. and G.C. All authors have read and agreed to the published version of the manuscript.

**Funding:** This research received no external funding.

**Institutional Review Board Statement:** Not applicable.

**Informed Consent Statement:** Not applicable.

**Acknowledgments:** The authors would like to acknowledge the Water Research Commission in South Africa who have funded numerous research projects from which this work emanates.

**Conflicts of Interest:** The authors declare no conflict of interest. The founding sponsors had no role in the design of the study, in the collection, analyses, or interpretation of data, in the writing of the manuscript, and in the decision to publish the results.

## Nomenclature

$C_t$	energy tariff at time period $t$ (unit cost/kW)
$F$	objective function (cost unit)
$g$	gravitational acceleration ( $m/s^2$ )
$H_t$	average head at time period $t$ (m)
$I_i$	impact factor (consequence)
$N_{max}$	maximum installed plant capacity (kW)
$N_{min}$	hydro power minimum power generation constraint (kW)
$P_i$	probability (%)
$R_i$	risk value for each component in the pipeline system which could have an impact on the reliability and needs to be assessed
$Q_t$	average water discharge in pipe system ( $m^3/s$ )
$Q_h$	average water discharge through turbine ( $m^3/s$ )
$Q_b$	average water discharge through bypass ( $m^3/s$ )

$Q_{t,max}$	maximum water discharge capacity of pipe system ( $m^3/s$ )
$Q_{t,min}$	minimum water discharge capacity of pipe system ( $m^3/s$ )
$Q_{h,t,max}$	maximum water discharge capacity of hydropower plant ( $m^3/s$ )
$Q_{h,t,min}$	minimum water discharge capacity of hydropower plant ( $m^3/s$ )
$Q_{b,t,max}$	maximum water discharge capacity of bypass ( $m^3/s$ )
$Q_{b,t,min}$	minimum water discharge capacity of bypass ( $m^3/s$ )
$T$	total period count for a week, $T = 672$ (15 min time steps)
$V_t$	volume of reservoir storage at the beginning of period $t$ ( $m^3$ )
$V_{t,max}$	maximum volume of reservoir storage ( $m^3$ )
$V_{t,min}$	minimum volume of reservoir storage ( $m^3$ )
$\alpha$	coefficient to incorporate variation in operational risk at reservoirs (risk quantification)
$\beta$	coefficient to incorporate variation in operational risk for pipe system (risk quantification)
$\Delta t$	time step (s)
$\rho$	density of water ( $kg/m^3$ )
$\eta_t$	hydropower plant efficiency at time period $t$ (%)

## References

- Sari, M.A.; Badruzzaman, M.; Cherchi, C.; Swindle, M.; Ajami, N.; Jacangelo, J.G. Recent Innovations and Trends in In-conduit Hydropower Technologies and Their Applications in Water Distribution Systems. *J. Environ. Manag.* **2018**, *228*, 416–428. [CrossRef] [PubMed]
- Pérez-Sánchez, M.; Sánchez-Romero, F.J.; Ramos, H.M.; López-Jiménez, P.A. Energy Recovery in Existing Water Networks: Towards Greater Sustainability. *Water* **2017**, *9*, 97. [CrossRef]
- Van Dijk, M.; Niebuhr, C.M.; Bekker, A.; Kurtz, A.A. Inline Pressure Wheel—Pico hydropower development. In Proceedings of the HYDRO—2020 IWRA Online Conference Addressing Groundwater Resilience under Climate Change, Online, 26–28 October 2020.
- Loots, I.; Van Dijk, M.; van Vuuren, S.J.; Bhagwan, J.N.; Kurtz, A. Conduit-hydropower potential in the City of Tshwane water distribution system: A discussion of potential applications, financial and other benefits. *J. South Afr. Inst. Civ. Eng.* **2014**, *56*, 2–13.
- White, J. Recovering energy from an existing conduit. *Int. Water Power Dam Constr.* **2011**, *63*, 18–20. Available online: <https://www.waterpowermagazine.com/features/featurerecovering-energy-from-an-existing-conduit/> (accessed on 12 April 2022).
- Lisk, B.; Greenberg, E.; Bloetscher, F. *Implementing Renewable Energy at Water Utilities—Case Studies*; Water Research Foundation: Denver, CO, USA, 2012.
- McNabola, A.; Coughlan, P.; Williams, A.P. Energy recovery in the water industry: An assessment of the potential of micro hydropower. *Water Environ. J.* **2014**, *28*, 294–304. [CrossRef]
- Van Vuuren, S.J.; Van Dijk, M.; Loots, I.; Barta, B.; Scharfetter, B.G. *Conduit Hydropower Development Guide*; WRC Report No TT597/14; Water Research Commission: Pretoria, South Africa, 2014.
- Southern Nevada Water Authority (SNWA). Sustainability in Action. 2010. Available online: [www.snwa.com/assets/pdf/reports-sustainability.pdf](http://www.snwa.com/assets/pdf/reports-sustainability.pdf) (accessed on 15 July 2021).
- Hennig, T.; Wang, W.; Feng, Y.; Ou, X.; He, D. Review of Yunnan’s hydropower development. Comparing small and large hydropower projects regarding their environmental implications and socio-economic consequences. *Renew. Sustain. Energy Rev.* **2013**, *27*, 585–595. [CrossRef]
- Van Vuuren, S.J.; Van Dijk, M.; Loots, I. *Conduit Hydropower Pilot Plants*; WRC Report No TT596/14; Water Research Commission: Pretoria, South Africa, 2014.
- Colombo, A.F.; Karney, B.W. Energy and Costs of Leaky Pipes: Toward Comprehensive Picture. *J. Water Resour. Plan. Manag.* **2002**, *128*, 441–450. [CrossRef]
- Ramos, H.; Borga, A. Pumps as turbines: An unconventional solution to energy production. *Urban Water* **1999**, *1*, 261–263. [CrossRef]
- Fecarotta, O.; Aricò, C.; Carravetta, A.; Martino, R.; Ramos, H.M. Hydropower Potential in Water Distribution Networks: Pressure Control by PATs. *Water Resour. Manag.* **2014**, *29*, 699–714. [CrossRef]
- Butera, I.; Balestra, R. Estimation of the hydropower potential of irrigation networks. *Renew. Sustain. Energy Rev.* **2015**, *48*, 140–151. [CrossRef]
- Fontana, N.; Giugni, M.; Portolano, D. Losses Reduction and Energy Production in Water-Distribution Networks. *J. Water Resour. Plan. Manag.* **2012**, *138*, 237–244. [CrossRef]
- Bonthuys, G.J.; Van Dijk, M.; Cavazzini, G. Energy Recovery and Leakage-Reduction Optimization of Water Distribution Systems Using Hydro Turbines. *J. Water Resour. Plan. Manag.* **2020**, *146*. [CrossRef]
- Parra, S.; Krause, S. Pressure Management by Combining Pressure Reducing Valves and Pumps as Turbines for Water Loss Reduction and Energy Recovery. *Int. J. Sustain. Dev. Plan.* **2017**, *12*, 89–97. [CrossRef]
- Patelis, M.; Kanakoudis, V.; Gonelas, K. Combining pressure management and energy recovery benefits in a water distribution system installing PATs. *J. Water Supply Res. Technol.—AQUA* **2017**, *66*, 520–527. [CrossRef]

20. Corcoran, L.; McNabola, A.; Coughlan, P. Optimization of Water Distribution Networks for Combined Hydropower Energy Recovery and Leakage Reduction. *J. Water Resour. Plan. Manag.* **2015**, *142*, 1–8. [[CrossRef](#)]
21. Caxaria, G.; Mesquita, D.; Ramos, H.M. Small Scale Hydropower: Generator Analysis and Optimization for Water Supply Systems. In Proceedings of the World Renewable Energy Congress, Linköping, Sweden, 8–13 May 2011; pp. 1386–1393.
22. Ramos, H.M.; Mello, M.; De, P.K. Clean power in water supply systems as a sustainable solution: From planning to practical implementation. *Water Sci. Technol. Water Supply-WSTWS* **2010**, *10*, 39–49. [[CrossRef](#)]
23. Jafari, R.; Khanjani, M.J.; Esmaelian, H.R. Pressure Management and Electric Power Production using Pumps as Turbines. *J. AWWA* **2015**, *107*, E351–E363. [[CrossRef](#)]
24. Lydon, T.; Coughlan, P.; McNabola, A. Pump-as-Turbine: Characterization as an Energy Recovery Device for the Water Distribution Network. *J. Hydraul. Eng.* **2015**, *143*, 04017020. [[CrossRef](#)]
25. Elbatran, A.H.; Yaakob, O.B.; Ahmed, Y.M.; Shabara, H.M. Operation, performance and economic analysis of low head micro-hydropower turbines for rural and remote areas: A review. *Renew. Sustain. Energy Rev.* **2015**, *43*, 40–50. [[CrossRef](#)]
26. Simão, M.; Ramos, H.M. Hydrodynamic and performance of low power turbines: Conception, modelling and experimental tests. *Int. J. Energy Environ.* **2010**, *1*, 431–444.
27. Razan, J.I.; Islam, R.S.; Hasan, R.; Hasan, S.; Islam, F. A Comprehensive Study of Micro-Hydropower Plant and Its Potential in Bangladesh. *Renew. Energy* **2012**, *2012*, 635396. [[CrossRef](#)]
28. Senior, J.A.; Muller, G.; Wiemann, P. The development of the rotary hydraulic pressure machine. In Proceedings of the 2007 32nd IAHR World Congress, Venice, Italy, 1–6 July 2007.
29. Senior, J.A.; Saenger, N.; Müller, G. New hydropower converters for very low-head differences. *J. Hydraul. Res.* **2010**, *48*, 703–714. [[CrossRef](#)]
30. Carravetta, A.; Del Giudice, G.; Oreste, F.; Ramos, H.M. PAT design strategy for energy recovery in water distribution networks by electrical regulation. *Energies* **2013**, *6*, 411–424. [[CrossRef](#)]
31. Arriaga, M. Pump as turbine—A pico-hydro alternative in Lao People's Democratic Republic. *Renew. Energy* **2010**, *35*, 1109–1115. [[CrossRef](#)]
32. Lima, G.M.; Luvizotto Junior, E.; Brentan, B.M. Selection and Location of Pumps as Turbines Substituting Pressure Reducing Valves. *Renew. Energy* **2017**, *109*, 392–405. [[CrossRef](#)]
33. Derakhshan, S.; Nourbakhsh, A. Experimental study of characteristic curves of centrifugal pumps working as turbines in different specific speeds. *Exp. Therm. Fluid Sci.* **2008**, *32*, 800–807. [[CrossRef](#)]
34. Nourbakhsh, A.; Jahangiri, G. Inexpensive small hydropower stations for small areas of developing countries. In Proceedings of the 1992 Conference on Advanced in Planning-Design and Management of Irrigation Systems as Related to Sustainable Land Use, Louvain, Belgium, 14–17 September 1992; pp. 313–319.
35. Fecarotta, O.; Carravetta, A.; Ramos, H.M.; Martino, R. An improved affinity model to enhance variable operating strategy for pumps used as turbines. *J. Hydraul. Res.* **2016**, *54*, 332–341. [[CrossRef](#)]
36. Ramos, H.M.; Dadfar, A.; Besharat, M.; Adeyeye, K. Inline Pumped Storage Hydropower towards Smart and Flexible Energy Recovery in Water Networks. *Water* **2020**, *12*, 2224. [[CrossRef](#)]
37. Creaco, E.; Galuppini, G.; Campisano, A.; Ciaponi, C.; Pezzinga, G. A Bi-Objective Approach for Optimizing the Installation of PATs in Systems of Transmission Mains. *Water* **2020**, *12*, 330. [[CrossRef](#)]
38. Pérez-Sánchez MSánchez-Romero, F.J.; Ramos, H.M.; López-Jiménez, P.A. Improved Planning of Energy Recovery in Water Systems Using a New Analytic Approach to PAT Performance Curves. *Water* **2020**, *12*, 468. [[CrossRef](#)]
39. Pérez García, J.; Cortés Marco, A.; Nevado Santos, S. Use of Centrifugal Pumps Operating as Turbines for Energy Recovery in Water Distribution Networks. Two Case Study. *AMR* **2010**, *107*, 87–92. [[CrossRef](#)]
40. Carravetta, A.; Fecarotta, O.; Del Giudice, G.; Ramos, H.M. Energy Recovery in Water Systems by PATs: A Comparisons among the Different Installation Schemes. *Procedia Eng.* **2014**, *70*, 275–284. [[CrossRef](#)]
41. Vilanova, M.R.; Balestieri, J.A. Hydropower recovery in water supply systems: Models and case study. *Energy Convers. Manag.* **2014**, *84*, 414–426. [[CrossRef](#)]
42. Shapes. *Energy Recovery in Existing Infrastructures with Small Hydropower Plants Multipurpose Schemes—Overview and Examples*; FP6 Project Shapes (work package 5-WP5) 2010; European Directorate for Transport and Energy: Brussels, Belgium, 2010.
43. Bonthuys, G.J.; Van Dijk, M.; Cavazzini, G. The Optimization of Energy Recovery Device Sizes and Locations in Municipal Water Distribution Systems during Extended-Period Simulation. *Water* **2020**, *12*, 2447. [[CrossRef](#)]
44. Bekker, A.; Van Dijk, M.; Bhagwan, J.N.; Niebuhr, C.M. Development of a framework to identify hydropower potential at pressure reducing stations in South African water supply and distribution systems. In Proceedings of the 2019 HYDRO Conference, Porto, Portugal, 14–16 October 2019.
45. Bekker, A.; Van Dijk, M.; Bhagwan, J.N.; Niebuhr, C.M. Development of a tool to identify hydropower potential at pressure reducing stations in South African water distribution systems. In Proceedings of the HYDRO 2020 Conference, Online, 26–28 October 2020.
46. Bekker, A.; Van Dijk, M.; Niebuhr, C.M.; Hansen, C.D. Framework Development for the Evaluation of Conduit Hydropower within Water Distribution Systems: A South African Case Study. *J. Clean. Prod.* **2020**, *283*, 1–15. [[CrossRef](#)]
47. Su, P.A.; Karney, B. Micro hydroelectric energy recovery in municipal water systems: A case study for Vancouver. *Urban Water J.* **2015**, *12*, 678–690. [[CrossRef](#)]



48. Venturini, M.; Stefano Alvisi, S.; Simani, S.; Manservigi, L. Energy Production by Means of Pumps as Turbines in Water Distribution Networks. *Energies* **2017**, *10*, 1666. [[CrossRef](#)]
49. Rodríguez-Pérez, A.M.; Pérez-Calañas, C.; Pulido-Calvo, I. Energy Recovery in Pressurized Hydraulic Networks. *Water Resour. Manag.* **2021**, *35*, 1977–1990. [[CrossRef](#)]
50. Choulot, A.; Denis, V.; Punys, P. Integration of Small Hydro Turbines into Existing Water Infrastructures. In *Hydropower—Practice and Application*; IntechOpen: London, UK. [[CrossRef](#)]
51. California Energy Commission (CEC). San Gabriel Valley Water Company “Plug-and-Play” In-Conduit Hydropower Development Project. Report no CEC-500-2021-032; 2021. Available online: <https://www.energy.ca.gov/sites/default/files/2021-05/CEC-500-2021-032.pdf> (accessed on 10 January 2022).
52. Asfar, A.; Jemaa, F.B.; Mariño, M.A. Optimization of Hydropower Plant Integration in Water Supply System. *J. Water Resour. Plan. Manag.* **1990**, *116*, 665–675.
53. Tarragó, E.F.; Ramos, H. Micro-Hydro Solutions in Alqueva Multipurpose Project (AMP) towards Water-Energy-Environmental Efficiency Improvements. Bachelor’s Thesis, Universidade de Lisboa, Lisboa, Portugal, 2015.
54. Corcoran, L.; Coughlan, P.; McNabola, A. Energy Recovery Potential Using Micro Hydropower in Water Supply Networks in The UK and Ireland. *Water Sci. Technol.-Water Supply* **2013**, *13*, 552–560. [[CrossRef](#)]
55. Novara, D.; Stanek, W.; Ramos, H. Energy Harvesting from Municipal Water Management Systems: From Storage and Distribution to Wastewater Treatment. Master’s Thesis, Universidade de Lisboa, Lisboa, Portugal, 2016.
56. Adhau, S.P.; Moharil, R.M.; Adhau, P.G. Mini-hydro power generation on existing irrigation projects: Case study of Indian sites. *Renew. Sustain. Energy Rev.* **2012**, *16*, 4785–4795. [[CrossRef](#)]
57. Sitzenfrei, R.; Von Leon, J. Long-time simulation of water distribution systems for the design of small hydropower systems. *Renew. Energy* **2014**, *72*, 182–187. [[CrossRef](#)]
58. Samora, I.; Franca, M.; Schleiss, A.; Ramos, H.M. Simulated Annealing in Optimization of Energy Production in a Water Supply Network. *Water Resour. Manag.* **2016**, *30*, 1533–1547. [[CrossRef](#)]
59. Samora, I.; Manso, P.; Franca, M.J.; Schleiss, A.J.; Ramos, H.M. Opportunity and Economic Feasibility of Inline Microhydropower Units in Water Supply Networks. *J. Water Resour. Plan. Manag.* **2016**, *142*, 04016052. [[CrossRef](#)]
60. Samora, I.; Manso, P.; Franca Mário Schleiss, A.; Ramos, H. Energy Recovery Using Micro-Hydropower Technology in Water Supply Systems: The Case Study of the City of Fribourg. *Water* **2016**, *8*, 344. [[CrossRef](#)]
61. Pérez-Sánchez, M.; Sánchez-Romero, F.; Ramos, H.; López-Jiménez, P. Modelling Irrigation Networks for the Quantification of Potential Energy Recovering: A Case Study. *Water* **2016**, *8*, 234. [[CrossRef](#)]
62. Cubides-Castro, E.D.; López-Aburto, C.S.; Iglesias-Rey, P.L.; Martínez-Solano, F.J.; Mora-Meliá, D.; Iglesias-Castelló, M. Methodology for Determining the Maximum Potentially Recoverable Energy in Water Distribution Networks. *Water* **2021**, *13*, 464. [[CrossRef](#)]
63. Carravetta, A.; Del Giudice, G.; Fecarotta, O.; Ramos, H. Pump as Turbine (PAT) Design in Water Distribution Network by System Effectiveness. *Water* **2013**, *5*, 1211–1225. [[CrossRef](#)]
64. Santolin, A.; Pavesi, G.; Cavazzini, G.; Ardizzon, G.; Perez-Diaz, J.I.; Van Dijk, M. Techno-economic feasibility analysis for energy production by variable speed Francis turbines in water distribution networks. In Proceedings of the 2017 HYDRO-Africa Conference, Marrakech, Morocco, 14–16 March 2017.
65. California Energy Commission (CEC). California’s In-Conduit Hydropower Implementation Guidebook—A Compendium of Resources, Best Practices, and Tools. Report no CEC-500-2020-030. Available online: [www.energy.ca.gov/sites/default/files/2021-05/CEC-500-2020-030.pdf](http://www.energy.ca.gov/sites/default/files/2021-05/CEC-500-2020-030.pdf) (accessed on 15 July 2021).
66. Kumar, D.; Katoch, S.S. Small hydropower development in western Himalayas: Strategy for faster implementation. *Renew. Energy* **2015**, *77*, 571–578. [[CrossRef](#)]
67. Tilmant, A.; Goor, Q.; Pinte, D. Agricultural-to-hydropower water transfers: Sharing water and benefits in hydropower-irrigation systems. *Hydrol. Earth Syst. Sci.* **2009**, *13*, 1091–1101. [[CrossRef](#)]
68. Alonso-Tristán, C.; González-Peña, D.; Díez-Mediavilla, M.; Rodríguez-Amigo, M.; García-Calderón, T. Small hydropower plants in Spain: A case study. *Renew. Sustain. Energy Rev.* **2011**, *15*, 2729–2735. [[CrossRef](#)]
69. Ohunakin, O.S.; Ojolo, S.J.; Ajayi, O.O. Small hydropower (SHP) development in Nigeria: An assessment. *Renew. Sustain. Energy Rev.* **2011**, *15*, 2006–2013. [[CrossRef](#)]
70. Vicente, S.; Bludszuweit, H. Flexible design of a pico-hydropower system for Laos communities. *Renew. Energy* **2012**, *44*, 406–413. [[CrossRef](#)]
71. Punys, P.; Dumbrasukas, A.; Kasiulis, E.; Vyciene, G.; Šilinis, L. Flow Regime Changes: From Impounding a Temperate Lowland River to Small Hydropower Operations. *Energies* **2015**, *8*, 7478–7501. [[CrossRef](#)]
72. Punys, P.; Dumbrasukas, A.; Kvaraciejus, A.; Vyciene, G. Tools for Small Hydropower Plant Resource Planning and Development: A Review of Technology and Applications. *Energies* **2011**, *4*, 1258–1277. [[CrossRef](#)]
73. Adeyeye, K.; Gallagher, J.; McNabola, A.; Ramos, H.M.; Coughlan, P. Socio-Technical Viability Framework for Micro Hydropower in Group Water-Energy Schemes. *Energies* **2021**, *14*, 4222. [[CrossRef](#)]
74. Van Dijk, M.; Van Vuuren, S.J.; Barta, B. Optimization of Energy Generation from Water Supply and Distribution Systems. In Proceedings of the 2012 HYDRO Conference, Bilbao, Spain, 29–31 October 2012.

75. Frijns, J.; Cabrera, E.; Carriço, N.; Covas, D.; Monteiro, A.J.; Ramos, H.M.; Bolognesi, A.; Bragalli, C.; Baki, S.; Makropoulos, C. Management Tools for Hydro Energy Interventions in Water Supply Systems. *Water Pract. Technol.* **2015**, *10*, 214–228. [CrossRef]
76. Itani, Y.; Soliman, M.R.; Kahil, M. Recovering energy by hydro-turbines application in water transmission pipelines: A case study west of Saudi Arabia. *Energy* **2020**, *211*, 118613. [CrossRef]
77. Pasha, M.F.K.; Weathers, M.; Smith, B. Water-Energy Storage Configuration for Generating Energy in Water Distribution Systems. In Proceedings of the ASCE World Environmental and Water Resources Congress, Henderson, NV, USA, 17–21 May 2020; Available online: <https://doi.org/10.1061/9780784482971.040> (accessed on 30 July 2017). [CrossRef]
78. Delplanque, J.; Cooperman, A.; Mann, S. Technical Assessment of In-Conduit Small Hydro Power Technologies. University of California, Davis. California Energy Commission. Publication number: CEC-500-2017-007-APL. 2014. Available online: [www.energy.ca.gov/2017publications/CEC-500-2017-007/CEC-500-2017-007-APL.pdf](http://www.energy.ca.gov/2017publications/CEC-500-2017-007/CEC-500-2017-007-APL.pdf) (accessed on 30 July 2017).
79. Van Dijk, M.; Van Vuuren, S.J.; Van Zyl, J.E. Optimising Water Distribution Systems using a weighted penalty in a Genetic Algorithm. *Water* **2008**, *3*, 5. [CrossRef]
80. Wu, C.; Fang, G.; Liao, T.; Huang, X.; Qu, B. Integrated Software Development and Case Studies for Optimal Operation of Cascade Reservoir within the Environmental Flow Constraints. *Sustainability* **2020**, *12*, 4064. [CrossRef]
81. Ahmadi, M.H.; Ahmadi, M.A.; Mellit, A.; Pourfayaz, F.; Feidt, M. Thermodynamic analysis and multi objective optimization of performance of solar dish Stirling engine by the centrality of entransy and entropy generation. *Int. J. Electr. Power Energy Syst.* **2016**, *78*, 88–95. [CrossRef]
82. Beiranvand, A.; Ehyaei, M.A.; Ahmadi, A.; Silvaria, J.L. Energy, exergy, and economic analyses and optimization of solar organic Rankine cycle with multi-objective particle swarm algorithm. *Renew. Energy Res. Appl.* **2020**, *2*, 9–23.
83. Ghazvini, M.; Pourkiaei, S.M.; Pourfayaz, F. Thermo-economic assessment and optimization of actual heat engine performance by implementation of NSGA II. *Renew. Energy Res. Appl.* **2020**, *1*, 235–245.
84. Hounnou, A.H.J.; Dubas, F.; Fifatin, F.; Chamagne, D.; Vianou, A. Multi-Objective Optimization of Run-of-River Small-Hydropower Plants Considering Both Investment Cost and Annual Energy Generation. *Int. J. Energy Power Eng.* **2019**, *13*, 17–21.
85. Dong, J.; Yang, P.; Nie, S. Day-Ahead Scheduling Model of the Distributed Small Hydro-Wind-Energy Storage Power System Based on Two-Stage Stochastic Robust Optimization. *Sustainability* **2019**, *11*, 2829. [CrossRef]
86. Keedwell, E.; Khu, S.-T. A hybrid genetic algorithm for the design of water distribution networks. *Eng. Appl. Artif. Intell.* **2005**, *18*, 461–472. [CrossRef]
87. Harpman, D.A. *Advanced Algorithms for Hydropower Optimization*; Technical Report S&T—2011-486; U.S. Department of the Interior, Technical Service Center, Bureau of Reclamation: Denver, CO, USA, 2012. Available online: [https://www.usbr.gov/research/projects/download\\_product.cfm?id=402](https://www.usbr.gov/research/projects/download_product.cfm?id=402) (accessed on 30 July 2017).
88. Michalewicz, Z. *Genetic Algorithms + Data Structures = Evolution Programs*, 2nd ed.; Springer: Berlin/Heidelberg, Germany, 1994.
89. Cheng, C.-T.; Wang, W.-C.; Xu, D.-M.; Chau, K.W. Optimizing hydropower reservoir operation using hybrid genetic algorithm and chaos. *Water Resour. Manag.* **2008**, *22*, 895–909. [CrossRef]
90. Chang, C.-C.; Van Zyl, J.E. Optimal reliability-based design of bulk water supply systems. *J. Water Resour. Plan. Manag.* **2014**, *140*, 1. [CrossRef]
91. Hokstad, P.; Røstum, J.; Sklet, S.; Rosén, L.; Pettersson, T.J.R.; Linde, A.; Sturm, S.; Beuken, R.; Kirchner, D.; Niewersch, C. *Methods for Risk Analysis of Drinking Water Systems from Source to Tap—Guidance Report on Risk Analysis*; Technau Report D 4.2.4; Technau: Marigny-le-Lozon, France, 2009.
92. Gonzalez Perea, R.; Ballesteros, R.; Ortega, J.F.; Moreno, M.A. Water and energy demand forecasting in large-scale water distribution networks for irrigation using open data and machine learning algorithms. *Comput. Electron. Agric.* **2021**, *188*, 106327. [CrossRef]
93. Rossman, L.A.; Woo, H.; Tryby, M.; Shang, F.; Janke, R.; Haxton, T. *EPANET 2.2 User Manual*; EPA/600/R-20/133; United States Environmental Protection Agency: Cincinnati, OH, USA, 2020.
94. Vieira, F.; Ramos, H.M. Optimization of operational planning for wind/hydro hybrid water supply systems. *Renew. Energy* **2009**, *34*, 928–936. [CrossRef]
95. Afshar, A.; Shafii, M.; Haddad, O.B. Optimizing multi-reservoir operation rules: An improved HBMO approach. *J. Hydroinformatics* **2011**, *13*, 121–139. [CrossRef]
96. Jamali, S.; Jamali, B. Cascade hydropower systems optimal operation: Implications for Iran’s Great Karun hydropower systems. *Appl. Water Sci.* **2019**, *9*, 66. [CrossRef]
97. Lin, N.M.; Tian, X.; Rutten, M.; Abraham, E.; Maestre, J.M.; Van de Giesen, N. Multi-Objective Model Predictive Control for Real-Time Operation of a Multi-Reservoir System. *Water* **2020**, *12*, 1898. [CrossRef]
98. Wu, J.; Liu, L.; Gao, J.; Wang, Q. Study on cascade hydropower alternative schemes based on multi-objective particle swarm optimization algorithm. Energy Reports. In Proceedings of the 6th International Conference on Power and Energy Systems Engineering (CPESE 2019), Okinawa, Japan, 20–23 September 2019; pp. 235–242. Available online: <https://www.sciencedirect.com/science/article/pii/S2352484719309412?via%3Dihub> (accessed on 30 July 2017).