

Chapter 3

Translating living heritage concepts into architectural form at the iron age ruins in Bronkhorstspuit

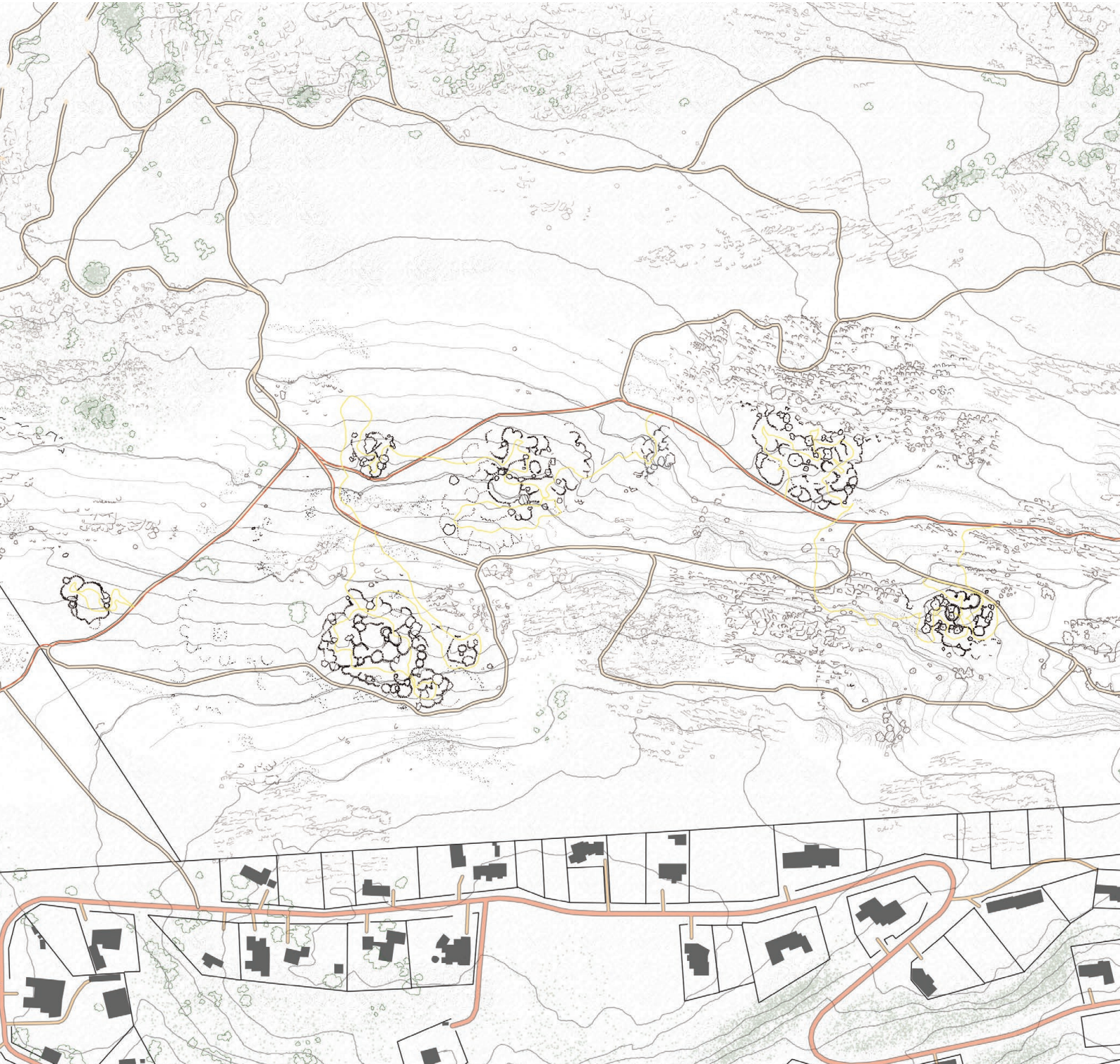

12. Introduction

This chapter describes the corporealisation of the previously determined conceptual plans by focusing on creating an informed architectural language and applying it in context. Positioned within global and local heritage paradigms, the project is fueled by a living heritage approach. The preceding chapter investigated various informants to generate a series of programmes that could achieve a living heritage response to the site and its imbedded cultural history and heritage value.

Herein, contextualisation will be explored through the delimitation of certain design tactics, the positioning of the plan concepts on site, and their acclimatisation to the site's conditions, both topographical and climatic. To achieve this, and the double purpose of unifying the architectural language of all five buildings, typical spatial details will be designed first. Each programme has unique components but can be abstracted to highlight common functional requirements. The spatial details will be informed by these requirements, designed for climate appropriateness, and used in combination to articulate each building. These details also serve as baseline components that can yield derivations which share conceptual and spatial intent but facilitate a unique variety of activities. Forming a lexicon, they are then used to translate the earlier plan concepts into detailed buildings with unified architectural intention.

The physical characteristics of the site will guide the manner in which the initial plan concepts need to be adjusted so that each suit the terrain and climatic factors of its position. Their morphological organisation needs to be iterated to accommodate supplementary programmes and services. Thereafter, the distanced interaction of each pavilion with the other and the users experience throughout the site must be explored. Finally, a description of each pavilion's design and programme is offered with the intention of communicating their genesis in the critiqued theory, their intention within the tangible and intangible context of the site and their resultant morphology.

13. Translating a living heritage concept into architectural intention

Jonathan Hill (2019) discusses coproduction as a reciprocal process of ruination in which people create a culture that is enacted upon the landscape yielding ruins in the long term upon which the process repeats. Ruins, while presenting with material and immaterial absence (Hill, 2019), offer a stage for speculation about future possibilities that can take place within their voids. The idea that ruination does not imply an endpoint, but rather a point for continuation, enforces a living heritage approach to ruins. Hartoonian (2012) discusses Alvar Aalto's notion of the tectonic landscape as a contemporary plane interrupted with markers of heterotopias. An instance of ruins offers a connection to a heterotopic past that can inform and drive ideation and architectural intent going forward. Ruins can be treated as the subject matter that is framed by programmes of heritage production in architecture that can facilitate it.

Certain limitations on form and technology need to be identified. Considering the ground condition, a minimally invasive approach is taken. Buildings are placed in association with the ruins, but for their preservation- buildings do not touch the ruins. Programme serves as the mediator between ruin and building and while ruins are included in the fabric of the heritage project, they are protected as well by the programmed buildings that frame them on the landscape. Where pertinent or poignant, excavation will be dealt with in a manner tantamount to archaeological practices. Instances where ground disturbance can occur include essential structure necessitated by spaces in close dialogue with the landscape or necessary services. Removed earth will be considered heritage material until it can be analysed to determine its value. Thereafter, such material can be reintegrated into the building fabric as bricks made in-situ. An opportunity for agency and authorship is offered in the analytical process and the production process of the building material. Material choices are markers of cultural interaction with the landscape. Other elements of stone and timber can bear their genesis in the landscape as well, and lend their characteristics to the buildings. Then, considering services, the remote nature of the buildings and a contemporary need for sustainable design reinforces the use of photovoltaic panels for electricity generation. Water access can be supplemented by rainwater harvesting and integrated water waste reduction systems can be used.

Considering this stance, the architecture of a living heritage project at a ruin site begins to address earlier issues of meaning, relevance, significance and interface. The significance of the heritage material can be promoted (in line with the South African policy on living heritage's goals (2009)) and used to drive development outwards (ICOMOS, 2011). A scheme like this could set a precedent for similar conservation schemes at other sites in South Africa enforcing a paradigm of iron age relevance and developments informed by their idiosyncratic meaning.

The following points sum up the translations of a living heritage concept into an architectural intention:

- The spaces should facilitate living heritage production in their flexibility and service access.
- The architectural language should highlight the interaction of culture with the landscape in its expression of materials made from the landscape.
- Technology should be suited to the site's sensitivity and environment.
- The buildings should, wherever possible, passively manage thermal comfort in an act of dialogue with the environment.
- The architecture should be precedential, inciting inspiration for the creation of such schemes elsewhere.

14. Layering informants onto architectural intention

Before further iteration of the plan concepts takes place, a need for an architectural language to contextualise, unify and define buildings arises. These details will be informed by the previous studies, further investigations into the characteristics of the site and common threads in functional needs of each building.

14.1. Responding to the landscape’s environmental characteristics

a) Creating thermal comfort

The iron age site within which this project has its footing, shapes not only the programme and plan concepts, but also the physical manifestation of the architecture. Situating the concepts on site and matching them to the environmental conditions will aid in creating a scheme that’s integrated with the landscape. An architecture that has thermal comfort, technical efficiency and terrain suitability requires a consideration of the climatic condition and the topography of the site. The Bronkhorstspuit region has hot summers with flash storms and shorter cooler winters with minimal rainfall (Weather Spark, 2021), very similar to the climate of Pretoria (Climate-data.org, 2021). The tables below compare the average high and low annual temperatures of Pretoria and Bronkhorstspuit, showing their similarity.

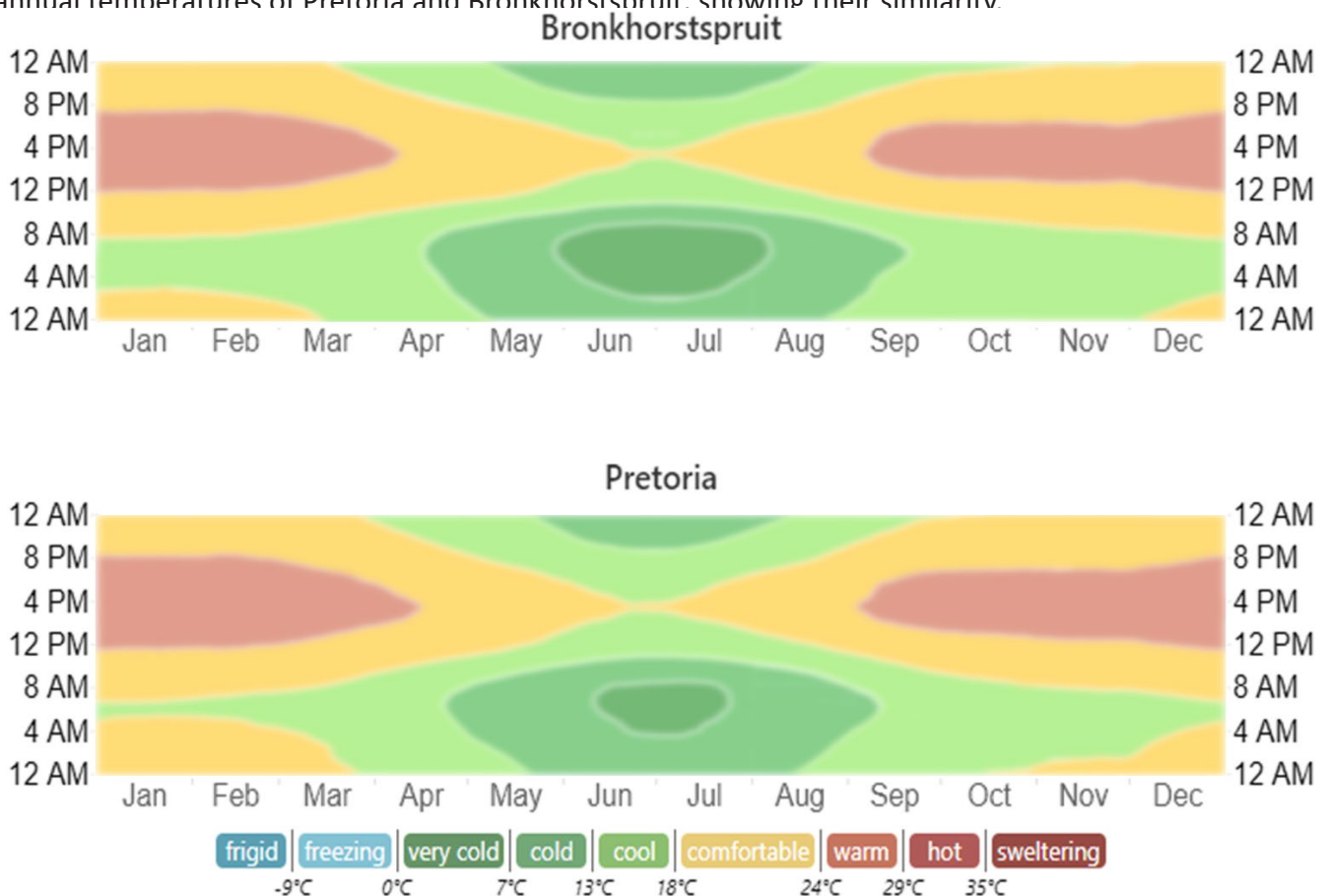

Figure 64: The table above compares the perceived comfort level of the ambient temperature of Pretoria and Bronkhorstspuit. Their similarity implies that climatic controls that suit conditions in Pretoria will be suitable in Bronkhorstspuit as well. The period from November to March require afternoon cooling strategies and the period from May to August require warming strategies to create thermal comfort (Data from Weather Spark, 2021).

	January	February	March	April	May	June	July	August	September	October	November	December
Avg. Temperature °C (°F)	20.7 °C (69.3) °F	20.7 °C (69.2) °F	19.4 °C (66.9) °F	18.6 °C (65.1) °F	13.7 °C (56.7) °F	11 °C (51.7) °F	10.7 °C (51.3) °F	14 °C (57.2) °F	17.7 °C (63.9) °F	19.4 °C (66.9) °F	19.8 °C (67.6) °F	20.6 °C (69) °F
Min. Temperature °C (°F)	15.7 °C (60.3) °F	15.6 °C (60) °F	14.2 °C (57.5) °F	11.2 °C (52.1) °F	7.4 °C (45.3) °F	4.4 °C (39.9) °F	3.8 °C (38.8) °F	6.6 °C (43.9) °F	10 °C (50.1) °F	12.6 °C (54.6) °F	13.9 °C (57.1) °F	15.4 °C (59.7) °F
Max. Temperature °C (°F)	26 °C (78.8) °F	26.1 °C (79) °F	25 °C (77) °F	22.5 °C (72.5) °F	20.6 °C (69.1) °F	18.3 °C (64.9) °F	18.3 °C (65) °F	21.8 °C (71.2) °F	25.4 °C (77.8) °F	26.5 °C (79.6) °F	26.8 °C (78.5) °F	26 °C (78.8) °F
Humidity(%)	67%	64%	63%	62%	52%	50%	44%	38%	36%	47%	58%	65%

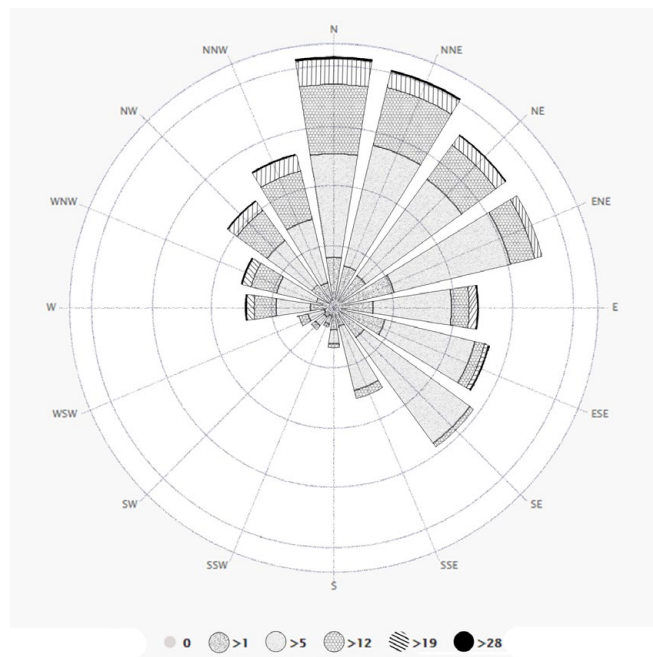
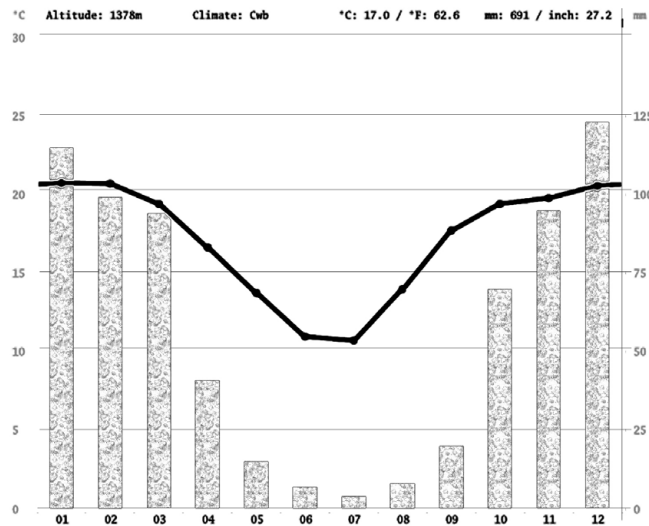

Figure 65: (top) A table summarising the monthly average temperature conditions of Bronkhorstspuit. The data depicts warm humid summers, and cold dry winters (Data from Climate-data.org, 2021).

Figure 66: (middle) This graph shows the correlation between seasonal temperature and rainfall, reinforcing the character of warm humid summers, and cold dry winters (Data from Climate-data.org, 2021).

Figure 67: (bottom) A wind rose diagram that shows a predominant yearly wind direction from the north and north east, with minimal south-western forces. This will facilitate buildings that face north with proper cross ventilation in summer (Data from Meteoblue.com, 2021).

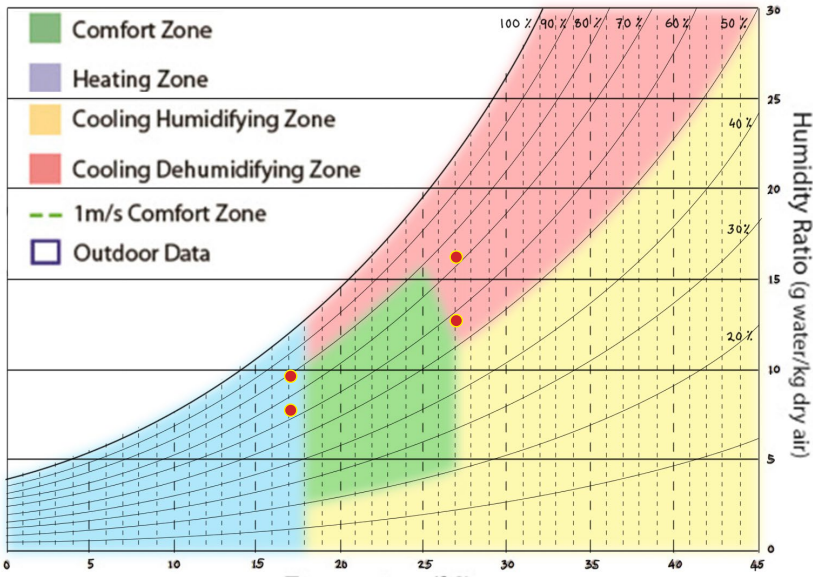

Figure 68: Bioclimatic psychrometric graph indicating the range of summer weather conditions in Bronkhorstspuit in comparison with the range of perceived thermal comfort. (Bioclimatic chart from Roshan, et al., 2017 based on Milne and Givoni, 1979)

Summer period: October to March according to figure 64

Temperature: 17-27 °C
Humidity: high 50-67%
Daylight: 8.8-9.8 hrs/day

Strategy: Ventilation removes hot and moist air (Holm, 1996).

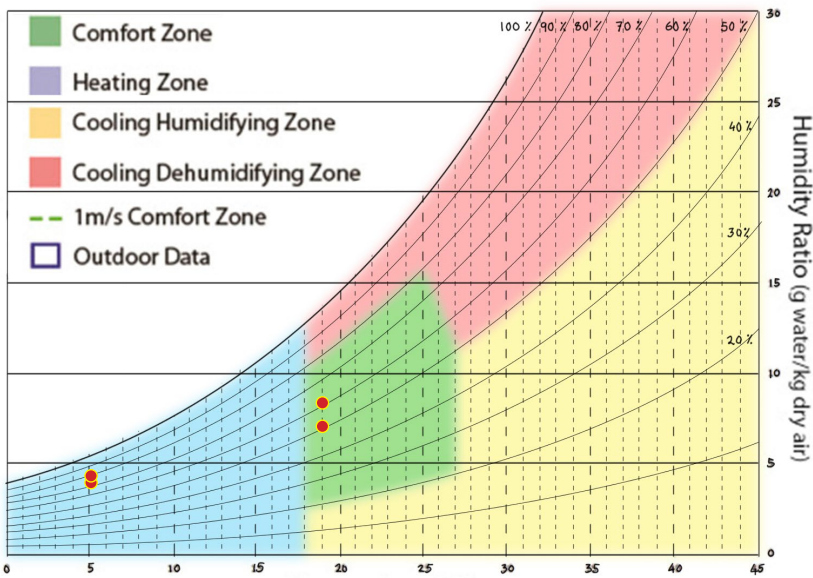

Figure 69: Bioclimatic psychrometric graph indicating the range of winter weather conditions in Bronkhorstspuit in comparison with the range of perceived thermal comfort. (Bioclimatic chart from Roshan, et al., 2017 based on Milne and Givoni, 1979)

Winter period: April to August according to figure 64

Temperature: low 5-19 °C
Humidity: low 38-52%
Daylight: 8.3-9.5

Strategy: Thermal mass elements with solar heat gain and insulated rooves (Holm, 1996).

These conditions necessitate cooling technologies and lower solar heat gain in summer. Where possible the buildings will be orientated facing north, with shorter elevations in the east and west, limiting harsh morning and afternoon heat (Holm, 1996), while still offering the opportunity to maximise interior daylight and take advantage of solar power. Shading on northern elevations (Holm, 1996:71) will be used to prevent excess interior solar heat gain in summer, with the benefit of solar heat gain in winter. Passive ventilation facilitated by smaller building widths (Holm, 1996:71). The role of a building skin with thermal mass, is in creating and maintaining cooler interiors to combat the harsh heat in the summer (Holm, 1996:30). In winter, thermal mass will aid in warming spaces up and the insulation will ensure maintenance of that heat. Importantly, the mechanisms used need to be adjustable. This implies the ability to close off ventilation and stop additional cooling during colder periods and rely on passive heating. This idea of adjustability will be explored further in the next section.

b) Sourcing water and electricity

Water catchment (when periodically available in summer months (Weather Spark, 2021)) can be used for irrigation and WC filling. However, there is not enough rainfall available year round for the buildings to be reliant on rainwater harvesting alone (Weather Spark, 2021). Water will have to be piped to the buildings from municipal connections, and rain water harvesting will supplement the overall water need and limit municipal reliance. The arrival pavilion can rely on its proximity to the suburbs for water and sewage connections. The heritage pavilion will have a boardwalk that leads from the arrival pavilion and along with it, bring water. This is similar to the research repository which will have a separate boardwalk connection in the east. The mediation node is further away from the ruin landscape and abuts the landowner's border, this allows for its source to be found in the northern municipal connections. Photovoltaic panels can be implemented in the buildings that require electricity and de-centralised septic tank systems can be used at ablution facilities to mitigate the need for large scale sewer line excavations. Once the resolved design plans are introduced later on, each building will be analysed according to its rainwater yield and solar-energy production based on the data provided in the tables below.

Precipitation / Rainfall	115	99	94	41	15	7	4	8	20	70	95	123
mm (in)	(4.5)	(3.9)	(3.7)	(1.6)	(0.6)	(0.3)	(0.2)	(0.3)	(0.8)	(2.8)	(3.7)	(4.8)
Humidity(%)	67%	64%	63%	62%	52%	50%	44%	38%	38%	47%	58%	65%
Rainy days (d)	11	9	8	5	2	1	1	1	2	7	10	12
avg. Sun hours (hours)	9.2	9.2	8.8	8.3	8.9	8.8	9.0	9.5	9.8	9.8	9.6	9.6

Average Monthly Rainfall

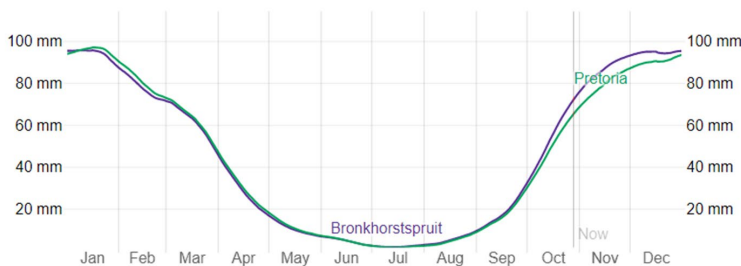

Average Daily Incident Shortwave Solar Energy

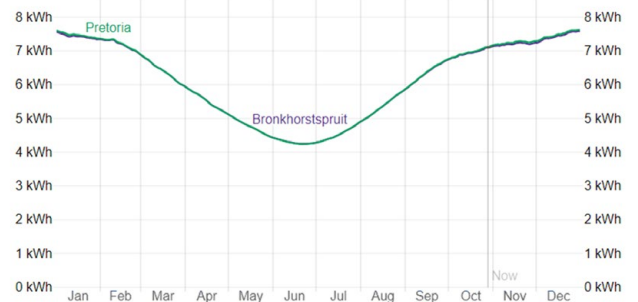

The average daily shortwave solar energy reaching the ground per square meter.

Rainfall	Jan	Feb	Mar	Apr	May	Jun	Jul	Aug	Sep	Oct	Nov	Dec
Bronkhorstspuit	95.8mm	78.1mm	63.3mm	28.9mm	10.0mm	5.1mm	1.9mm	5.2mm	16.7mm	56.0mm	86.8mm	95.1mm
Pretoria	97.1mm	80.9mm	64.4mm	30.5mm	10.8mm	5.1mm	1.8mm	4.7mm	15.7mm	51.1mm	79.4mm	90.6mm

Solar Energy (kWh)	Jan	Feb	Mar	Apr	May	Jun	Jul	Aug	Sep	Oct	Nov	Dec
Bronkhorstspuit	7.4	7.2	6.4	5.5	4.7	4.3	4.6	5.4	6.4	7.0	7.2	7.5
Pretoria	7.5	7.2	6.4	5.5	4.7	4.3	4.6	5.4	6.4	7.0	7.3	7.5

Figure 70: (top) A table summarising the monthly average rainfall and daylight quantities for use in calculating solar power and water catchment capacity (Data from Climate-data.org, 2021).

Figure 71: (bottom left) A graph showing the monthly average rainfall amounts in Bronkhorstspuit for use in calculating water catchment capacity (Data from Weather Spark, 2021).

Figure 72: (bottom right) A graph showing the average daily incident shortwave solar energy in Bronkhorstspuit for use in calculating solar power generation capacity (Data from Weather Spark, 2021).

c) Conditions for ground interference

The terrain varies between each site, where some are dappled with rocky outcrops, others are sparse and open. A micro-pile foundation system paired with decking necessitated by a desire for minimal ground disturbance, will be used and adjusted to suit each building's condition. Where rocks are in the way, a chemically bonded footing can stand in place of the pile. Suspended structures on pad footings will be used to create large areas of cover while minimising the need for many vertical support members. Where communion with the landscape is prioritised, raft foundations will be used in line with the sensitive excavation mentality described previously to create larger and more important spaces.

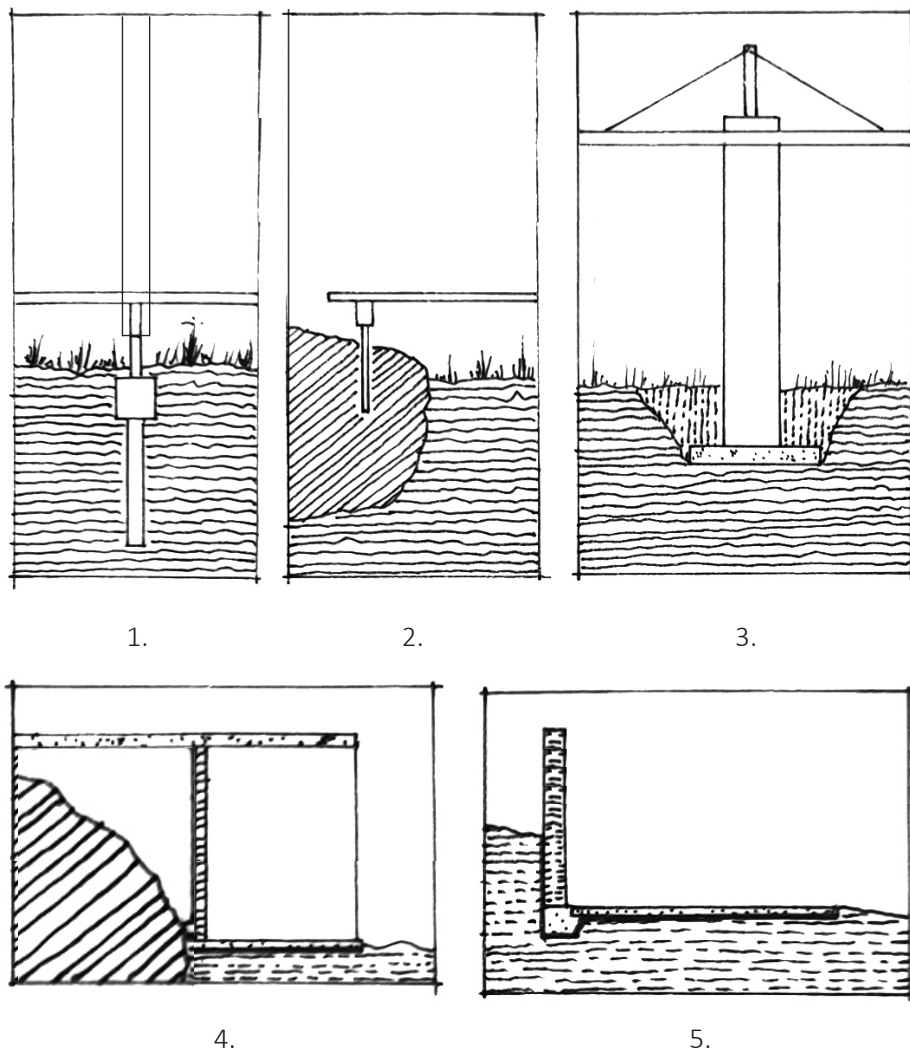

Figure 73: Diagrams showing the scale of ground disturbance used to create a hierarchy of sacredness. (1.) Micro-pile foundation (2.) Chemically bonded pin footings (3.) Pad footing (4.) Structural niches (5.) Raft foundations (Author, 2021).

14.2. Conceptualising and informing typical spatial details

The architectural language that will be used to realize each building in this project is informed not only by the living heritage programmes and physical features of the site, but by the experience of these layers as well. The experience of the living heritage process is understood from two perspectives- the practitioner and the observer (informed by van Vuuren's (2001) critique of the roles involved in commodified culture). These categories consider the general role of all involved groups and offer a lens with which to define typical architectural details. The experience of the culture, the landscape, and their interaction as a heritage site can be summed up into processes of production, observation, and transition. To follow, the conceptualisation of each spatial detail is described and thereafter, the technical design of each is defined.

- Production is about the activities within culture manifesting as tangible works. It requires enclosure to protect sacredness, imply introspection and facilitate ideation based on memory inherent in the notion of ruins. These spaces can be occupied by various practitioners depending on the programme it is used in. Practitioners can include artists, archaeologists and scholars.
- Observation maintains practitioner agency but offers the chance for engagement with tangible work by observers. A bifurcated enclosure with open niches implies a hybridisation of introspection and extrospection. The physical aspects of heritage extraction and production displayed within the backdrop of the landscape.
- Transitions stitch together the experience of practitioner and maker, between programmes and the landscape. Minimum enclosure is used, implying a landscape and wayfinding priority. Cases of internal transitions can make allowance for the attachment of programmed spaces.

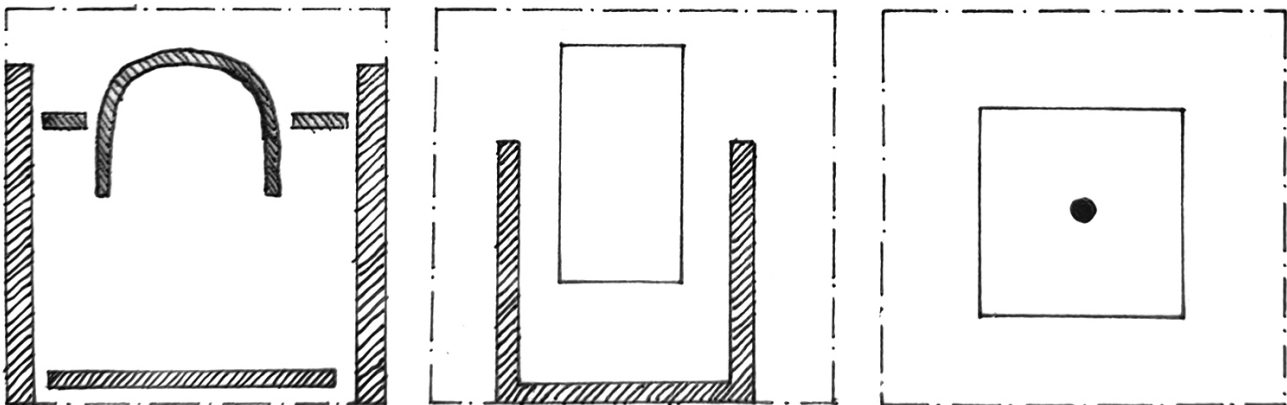

Figure 74: (left to right) Parti diagrams representing three levels of enclosure to accommodate common spatial details. Enclosed spaces for production type programmes, hybridised enclosure for observation type programmes, and minimal enclosure for transition type programmes (Author, 2021).

The architectural language of each typical detail considers all the aforementioned layers of informants and attempts to sum them up into a lexicon of usable parts for the consistent articulation of spaces at each building. Each is described according to its primary, secondary and tertiary structural components in the sections to follow. Thereafter these typical components are applied to the plan concepts, where in each case the programme creates the layout, the landscape drives morphology and the details drive resolution. A reminder of the programmes generated in chapter two is given below.

- Arrival pavilion
- Mediation node
- Heritage gallery
- Navigation platforms
- Research repository

a) Production

The production detail is a platform for discussions and for meetings, and a studio for creating and generating works. A light well creates interior daylighting without unnecessary solar heat gain and imitates the private exterior typology observed in the ruins (seen in figure 50 Chapter 2). Household courtyards and built-in niches were used for daily activities, in turn, contributing to the cultural fabric of the iron age society. The light well doubles as a heat stack- facilitating the escape of rising heat. When necessary, the building can be opened and the short width can allow air to move through the building (Holm, 1996). A large sliding door can move open to accommodate the transport of furniture, tools and artefacts as well as facilitate the aforementioned cross ventilation. Deeper northern facades, achieved with extended overhangs, ensure minimal heat gain in the warmer months. Thermal massing on the eastern and western sides can aid in maintaining a constant interior temperature through colder months as well. The intention is to create a building skin that can be adapted to changing exterior conditions and achieve internal thermal comfort regardless. In colder months, the spaces can be closed up and allowed to gain heat from solar heat gain, in warmer months, passive ventilation can get rid of warmer air.

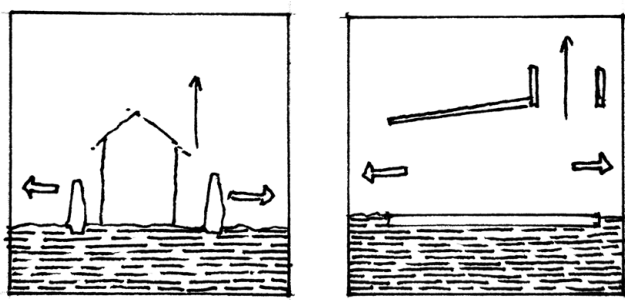

Figure 75: Diagrams comparing historical spatial units and their translation into new form, where visual access focuses on the horizontal plane with a skyward openness (Author, 2021).

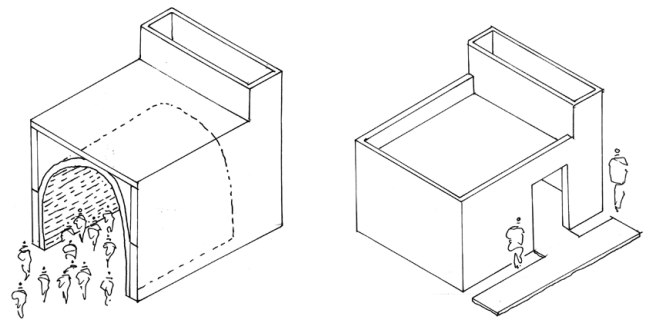

Figure 76: Diagrams showing potential derivations of the production spatial detail as social and research based spaces (Author, 2021).

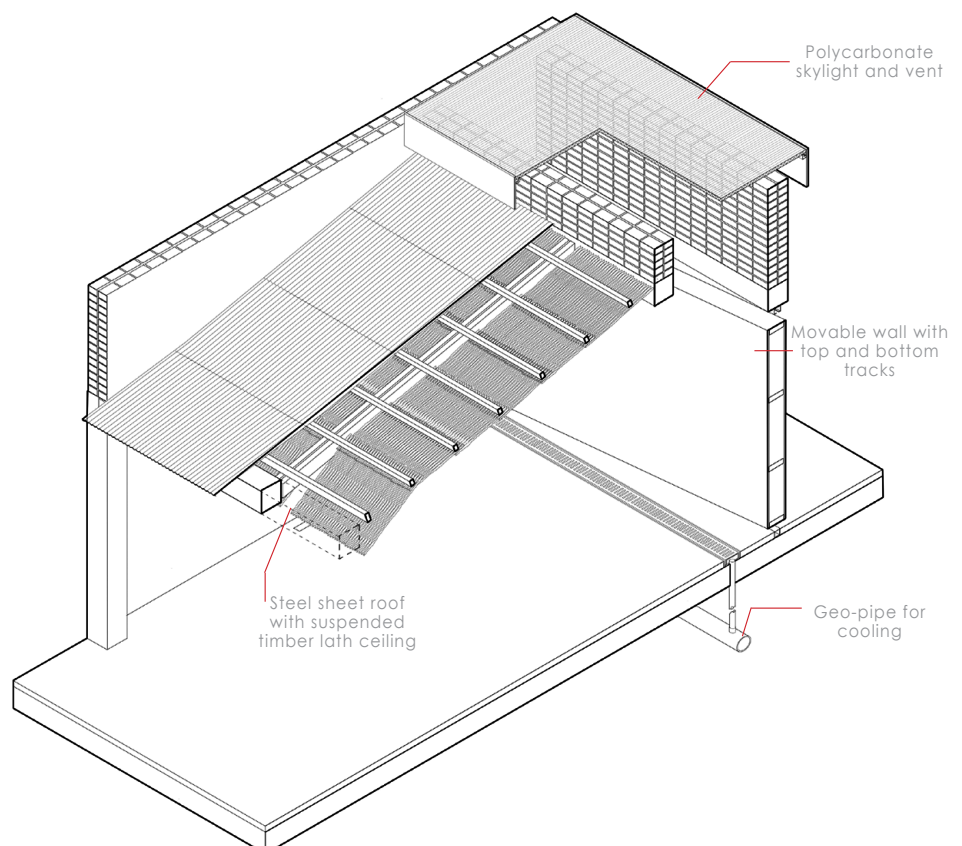

Figure 77: Axonometric section of the production detail indicating its materiality (Author, 2021).

b) Observation

The observation detail intends on creating spaces for observing the landscape and the works created within it. Displays can be filled with works of archaeological and contemporary origin. Earlier, the notion of reused and sensitively examined excavation material was described. In this detail, the ground material is to be converted into earthen bricks and used as roof tiles. The translucent roof sheeting allows daylight to fall through earthen tiles and create an interior experience crafted out of the terrain below. This imbeds the structure with social value through craftsmanship, but also highlights the need to treat any earth matter removed from the site with care and consideration. The roof sheet is separated from the tiles to allow space between the elements for ventilation and, the top of the tiles will be painted with a reflective paint to reduce excess heat absorption and transfer as well. The detail can accommodate passive ventilation to combat any further heat gain. Observing the cultural facets of the site in association with the landscape asks for an open typology, this necessitates raised enclosures as artefact storage that provides protection from the elements. The vertical supports are on pad foundations, but the remainder of the floor surface can be achieved with decking, simultaneously diverting any stray water away.

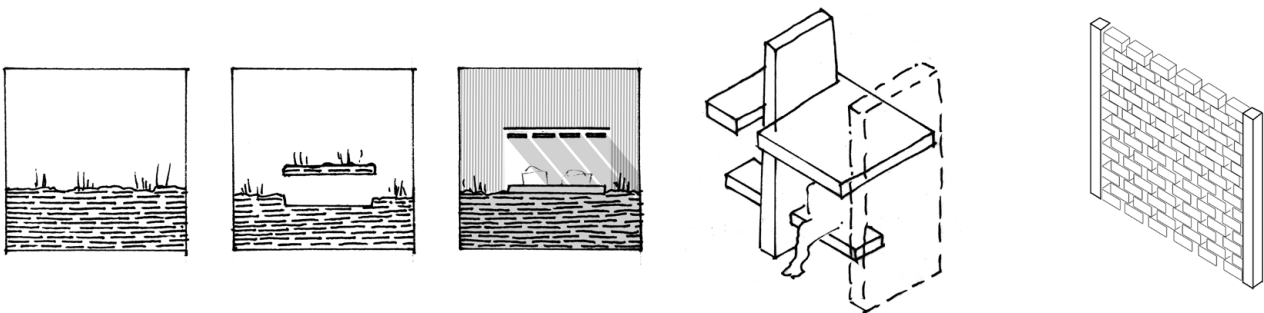

Figure 78: A sequence of diagrams showing the reuse of excavated earth matter as roof tiles that cast patterned light into the space below (Author, 2021).

Figure 79: Diagrams showing potential derivations of the observation spatial detail as a extrospective and introspective building skin (Author, 2021).

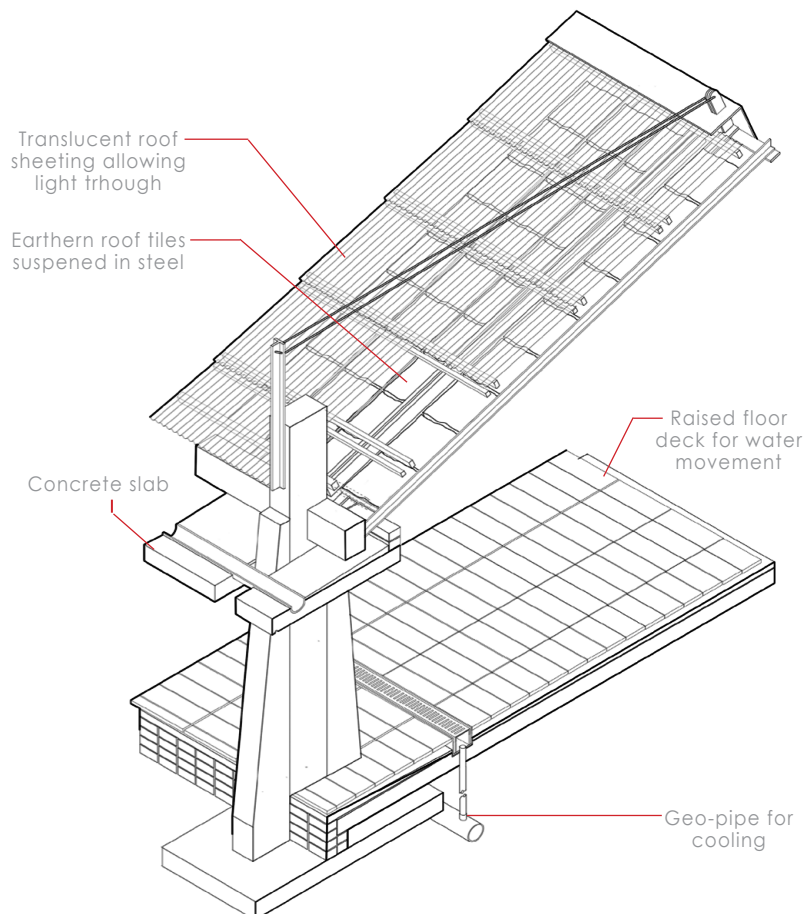

Figure 80: Axonometric section of the observation detail indicating its materiality (Author, 2021).

c) Transition

The transition detail intends on creating a unique shading device made of the landscape that can be used to shape spaces of movement. Predominantly used at the navigation platforms, it can also be used to articulate passages and walkways. The suspended timber lath shading device can be shaped to create spatial variation below. It speaks of the materials on the landscape and finds inspiration in the physical barriers suggested to have been on top of the stone walls before their ruination. These would not have been visual barriers, but physical, and in the context of this detail they are visual markers that shape wayfinding. The elements are allowed to pass through the detail in a translated way, sunlight is filtered and rain is dissipated. Underneath, decking is used to minimise ground disturbance. Decking can also serve in cases where services need to be transported over larger stretches of landscape, which would alternatively be imbedded in the ground.

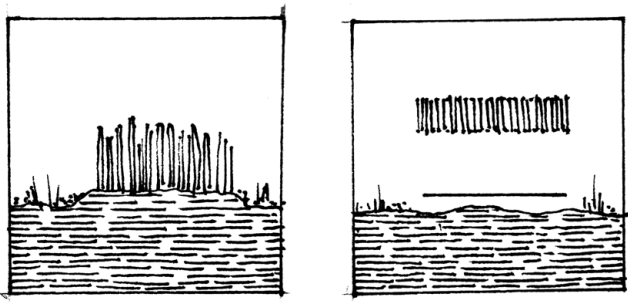

Figure 81: Diagrams showing the use of on-site materials to create heightened experiences of the landscape (Author, 2021).

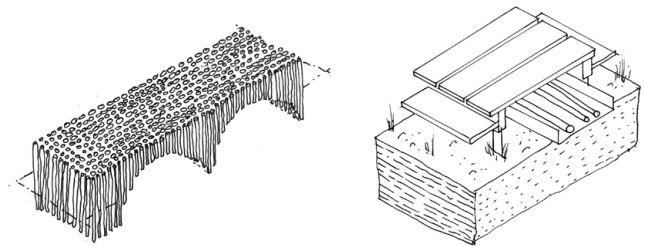

Figure 82: Diagrams showing potential derivations of the transition spatial detail as a hierarchical ceiling device and service delivery boardwalk (Author, 2021).

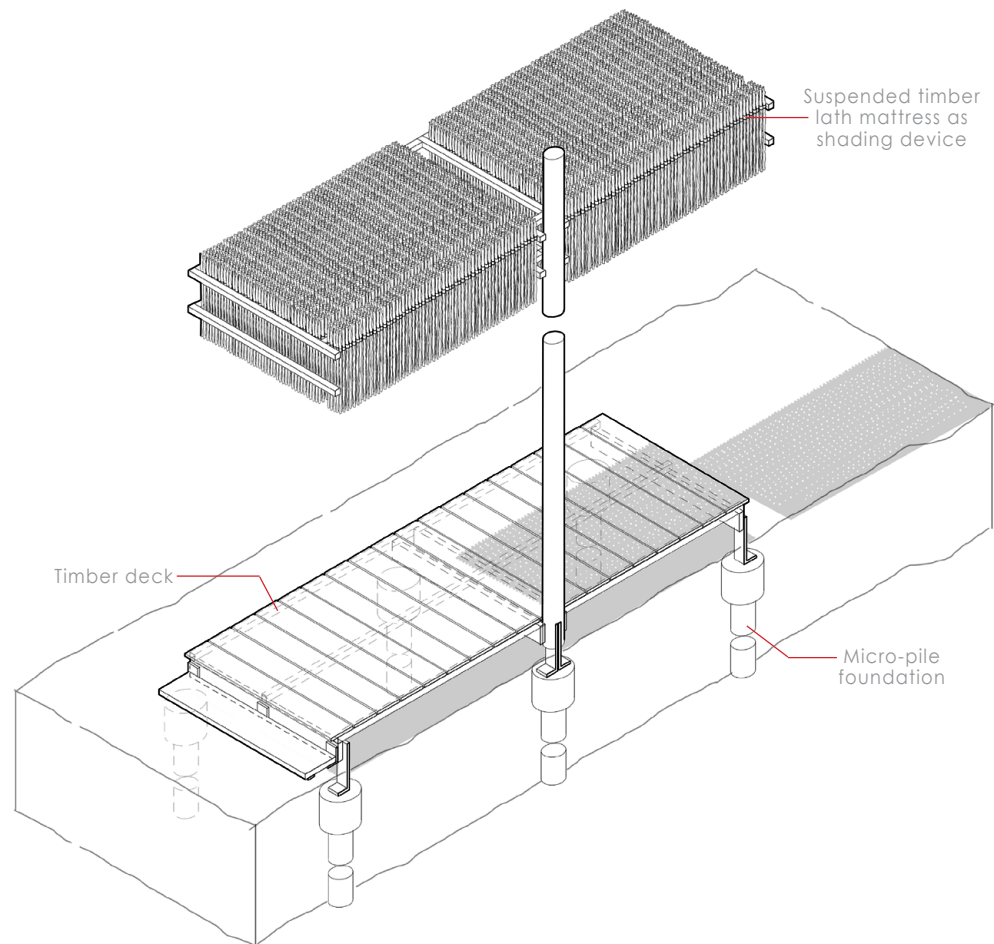

Figure 83: Axonometric section of the transition detail indicating its materiality (Author, 2021).

15. Informing the placement of the plan concepts

The above spatial details will serve as components that can be assembled to articulate each plan concept. Before the plan concepts can be appropriately designed, they need to be given physical sites. Their position will give each programme's plan an idiosyncratic situation to respond to. The following informants are kept in mind when determining placement;

- Each plan is placed in proximity to the entities they represent the relationship for. For example, the mediation node programme, which represents the relationship between current landowners and the heritage landscapes they own, will be positioned between the two entities- marking a symbolic mediated boundary.
- The positioning is also limited by a need to prevent unnecessary destruction to the ruins. Framing the ruins, the plans will not directly interfere with the ruins and rather facilitate a programmatic interaction with the ruins.
- On a practical scale, placement is also informed by ease of access to water and existing dirt roads. Terrain will also shape placement. Where rocky outcrops and trees exist, the plan will have to be adjusted to fit between, within and upon such features. Wind direction and northern solar exposure also guide orientation and inform design strategies.

The maps to follow depict the placement logic of each conceptual plan and indicate an overall arrangement of the programmes they facilitate in a framework around the ruins.

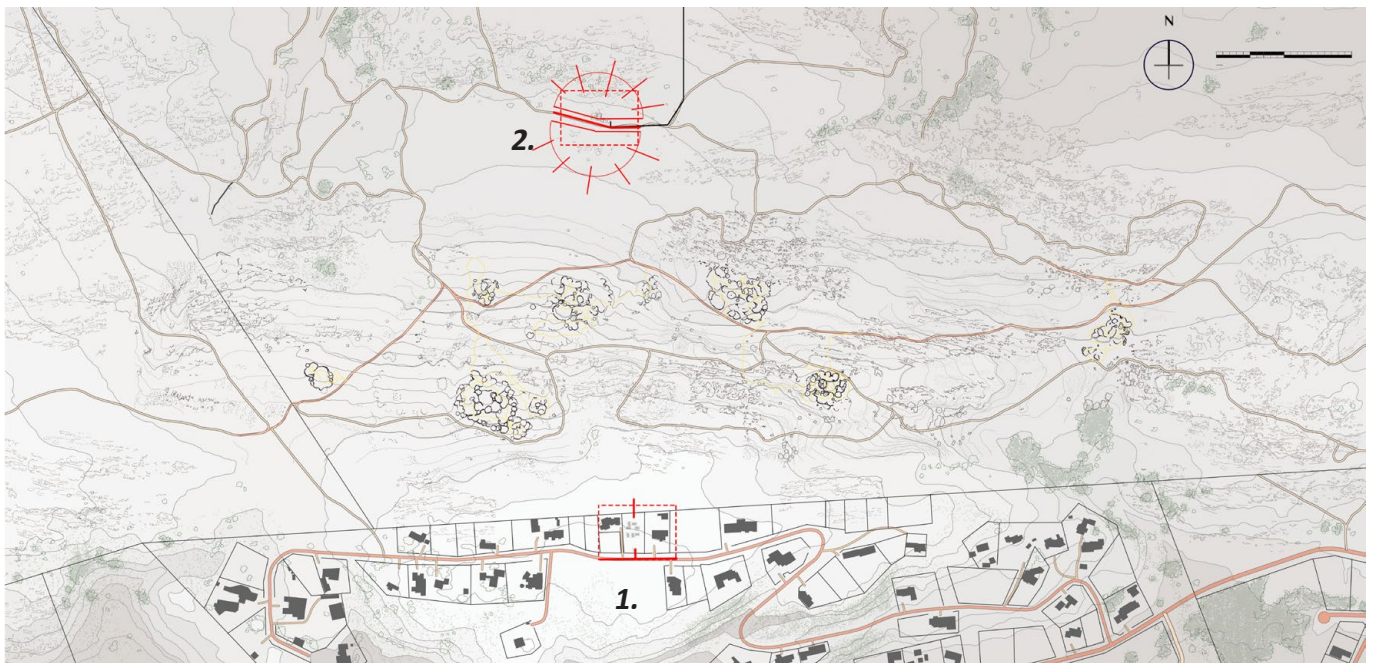

Figure 84: A site map indicating the placement of the arrival pavilion (1.) on an open plot of land within the suburbs to serve as a main access point to the site, and the placement of the mediation node (2.) on the northern boundary of the site abutting the landowner's property and the newly negotiated protected heritage landscape. Both have access to main roads and services and act as thresholds between contrasting conditions (Author, 2021).

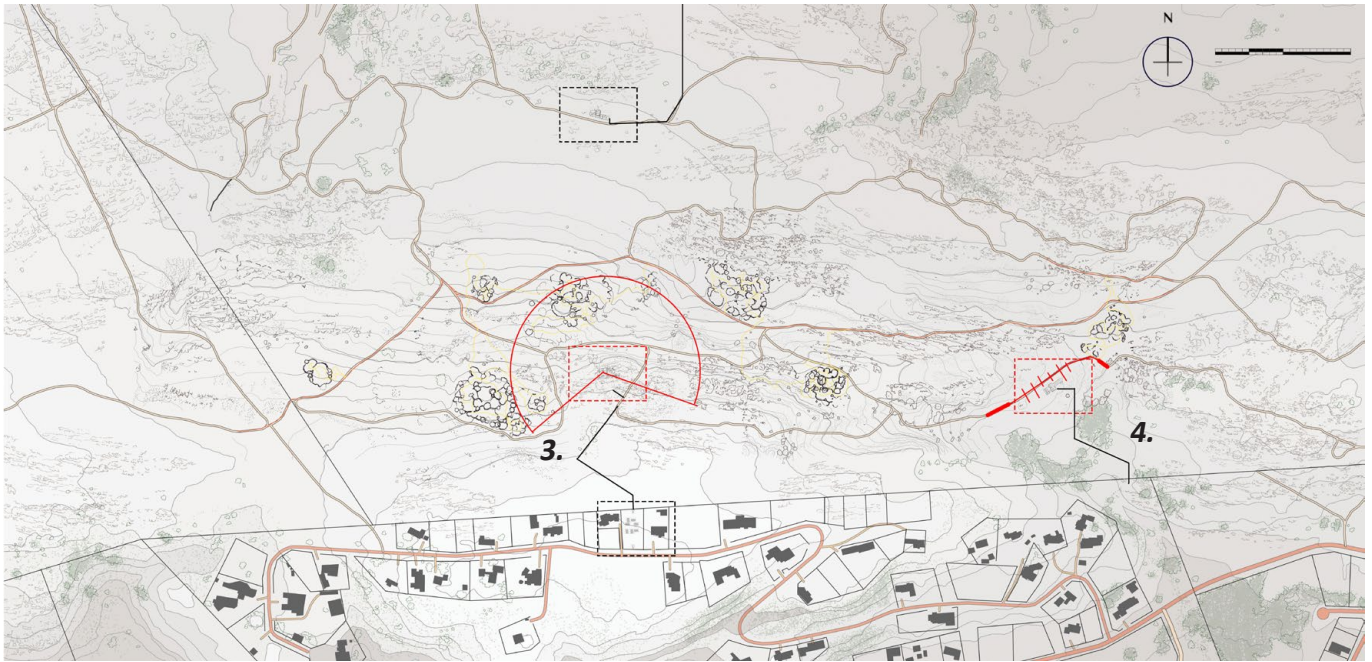

Figure 85: A site map indicating the placement of the heritage gallery (3.) on a central hill with vistas facing the surrounding ruins. It is close to an existing dirt road and can be reached via a boardwalk from the arrival pavilion that carries water with it as well. The research repository (4.) is placed to the east, adjacent to the main set of ruins and before the easternmost one with a dual boardwalk and service access path as well. It is attached to an existing dirt road for ease of transport to and from archaeological sites (Author, 2021).

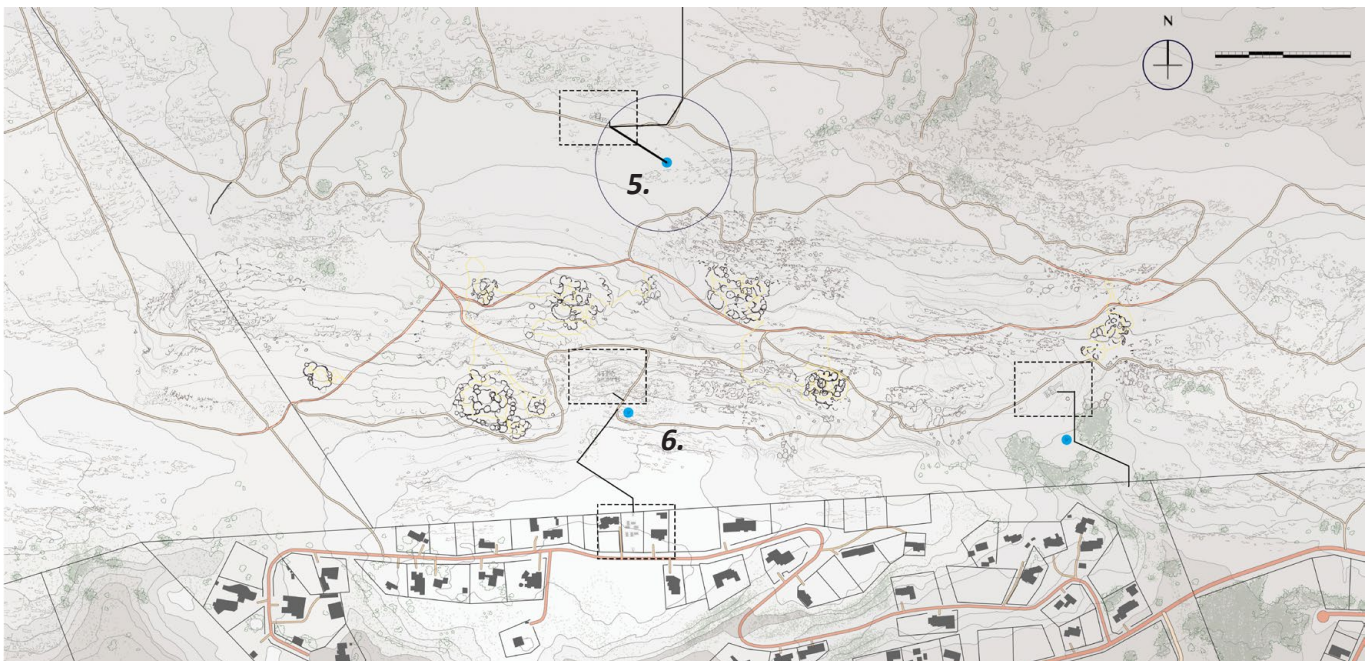

Figure 86: A site map indicating the placement of initial navigation platforms. The northern platform (5.) is placed amidst a rocky outcropping 100m away from the mediation node. The southern platform (6.) is placed at the intersection of an existing road and the boardwalk. Both extend the access of the initial buildings and offer a transition towards the other navigation platforms placed around the site (Author, 2021).

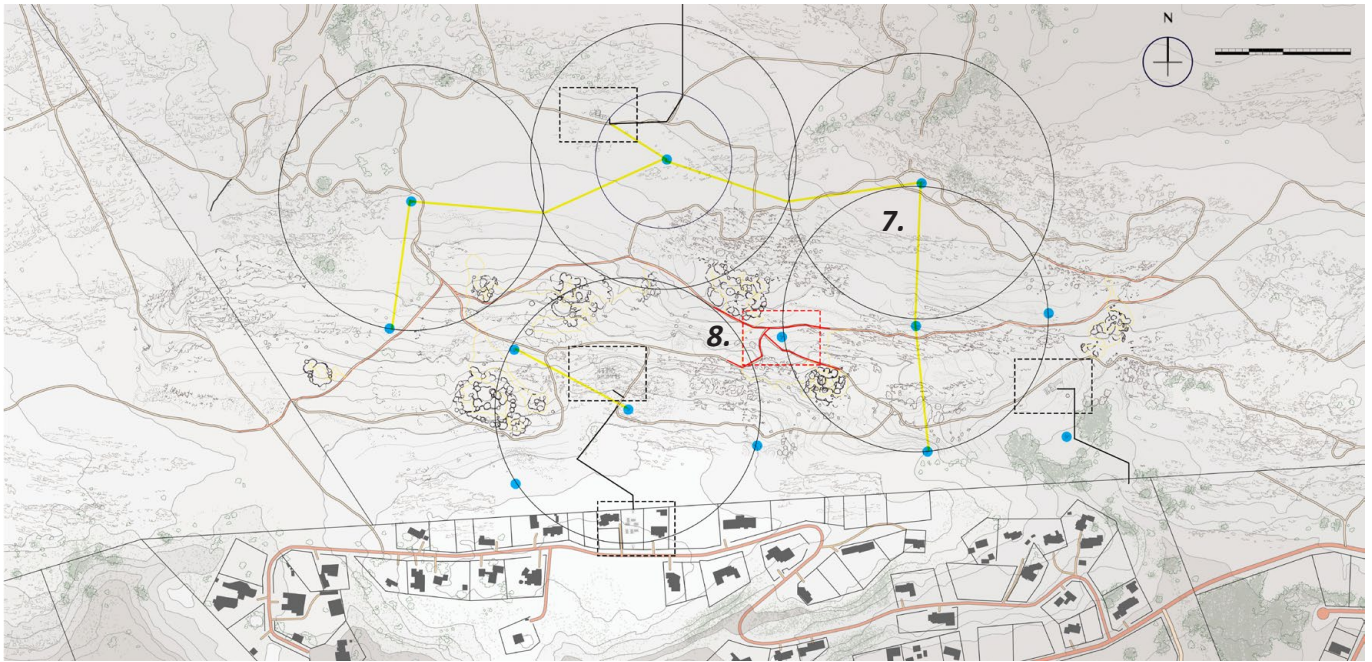

Figure 87: A site map indicating the placement of the remaining navigation platforms at the intersection of a 200m walking radius and existing dirt roads. These offer vistas and facilitate wayfinding between and around the ruins (Author, 2021).

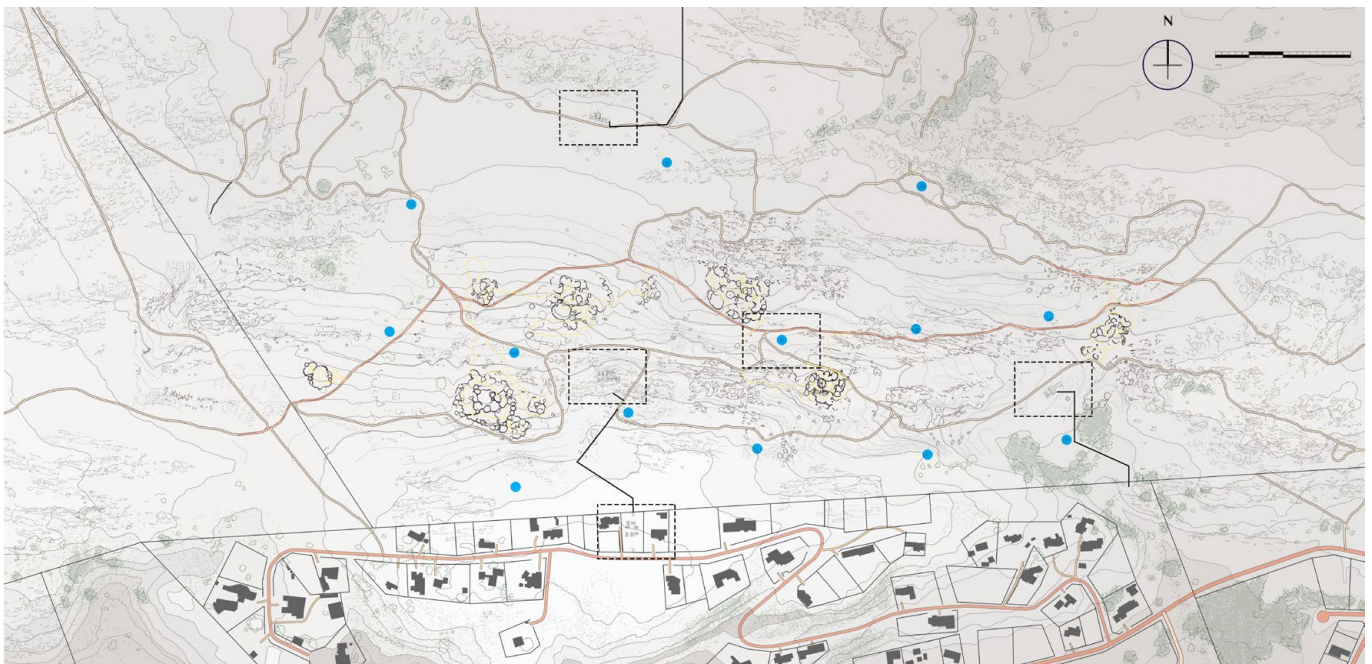

Figure 88: A site map indicating the five sites of building placement (Author, 2021).

While each building's separation allows the ruins to be framed within the overall programme, the architectural language employed requires consistency for the sake of architectural coherence. Arising from similar functional requirements at each building, this coherence can be achieved through designs of typical spatial details that can be adjusted and assembled according to the requirements of each building. The next section explores the physical parameters that guide the design of the spatial details, whereafter, they will be applied to the conceptual plans.

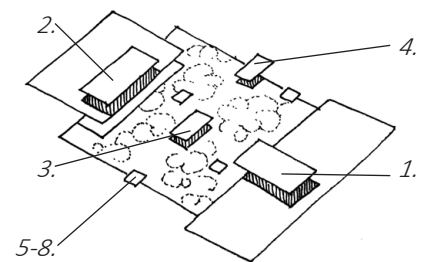
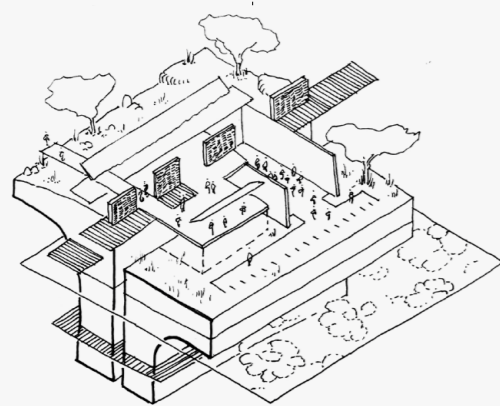
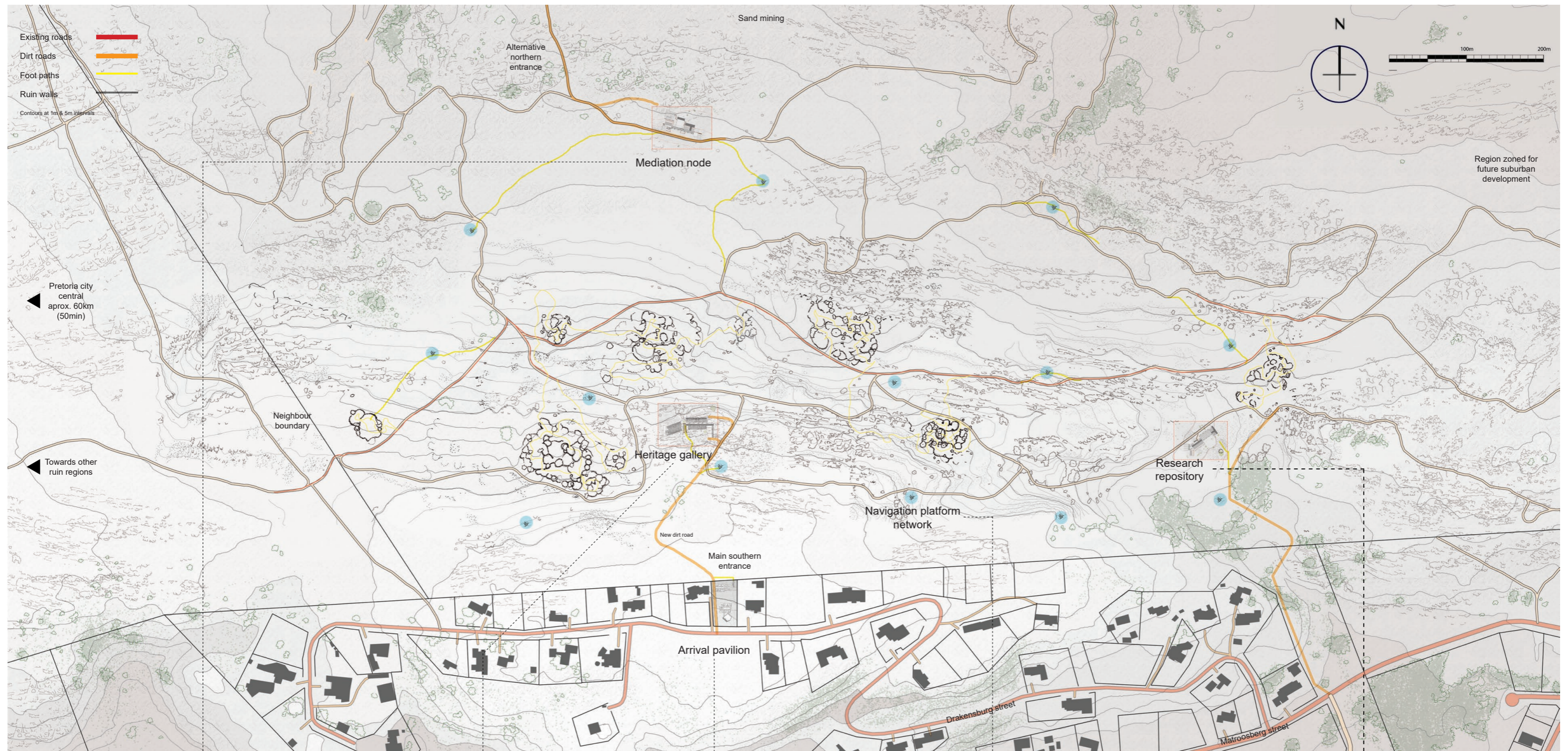
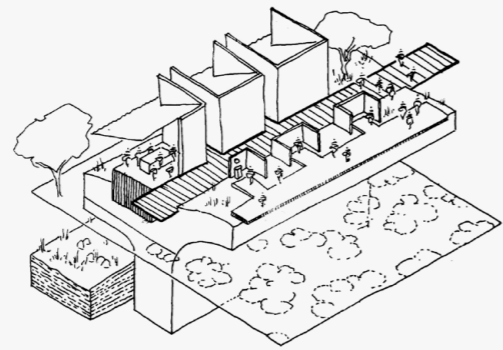

Figure 89: An abstract expression of the relationship between the five programmes (Author, 2021).



Mediation node



Heritage gallery

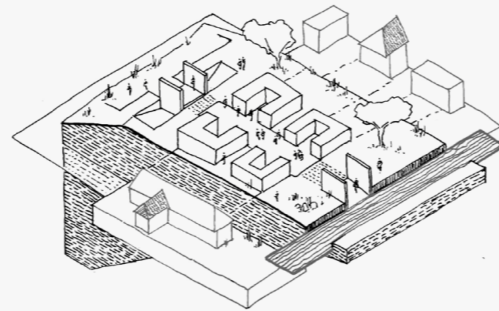

Arrival pavilion

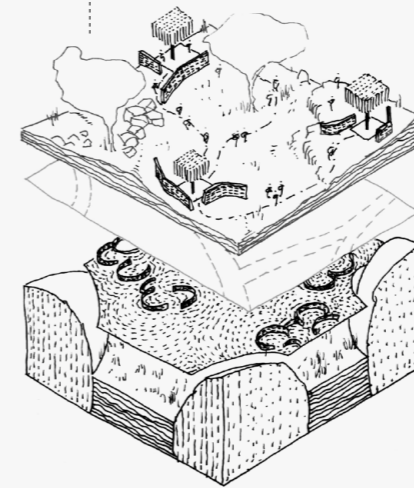

Navigation platform network

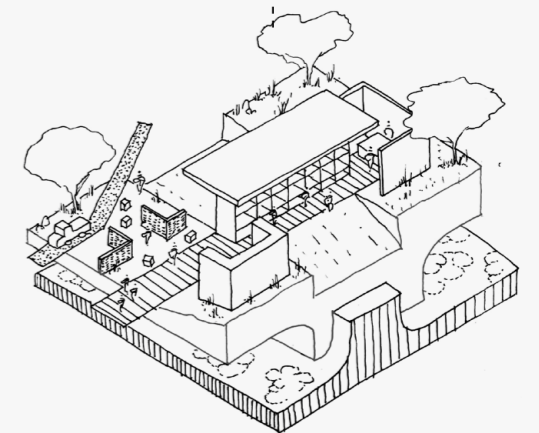

Research repository

16. Bringing architectural intention and plan concepts together

The following section serves to describe the designs of each building contained within this scheme's framework. Each building is described according to the following points:

- Its genesis in the programme generation experiment and development through each subsequent layer of design informants- in the form of a genealogy diagram.
- Its articulation through the combination of the typical spatial details described previously and acclimatisation to its specific site conditions- in the form of sequential spatial section diagrams.
- Its resultant morphology as the product of the overlap and synthesis of all the preceding informants- in the form of plan drawings in context.

Lastly, each building is given an SBAT rating (Sustainable building assessment tool) and analysed for its rain-water harvesting capacity and solar power generation capacity.

16.1. Arrival pavilion

The arrival pavilion is the general gate to the site and offers a threshold from the suburban context into the heritage context of the iron age ruin landscape. It bears morphological markers in position and scale to the adjacent sites, but relies on the typological language of the project to find its architectural form. Orientated on a north-south axis parallel with the site, longer east and west facing elevations arise. Unnecessary interior heat gain can be mitigated on these exposed elevations with shading devices and thermal massing. Daylight can be brought into interior spaces using the production typology and its light wells.

The arrival pavilion serves to introduce outsiders to the site and create an experience of transition. Furthermore, accommodation units are included here as a means of housing travelling visitors, practitioners part of the residency and special guests. Small units consisting of ablutions, a bedroom and a kitchenette are organised around courtyards to facilitate social interaction.

Positioned within the suburbs, the heritage sensitivity of this site is reduced. Therefore, the accommodation units are treated with continuous concrete foundations, rather than raised floors. Decking is used to guide movement between spaces, and dirt roads are used on the periphery to connect vehicular access to the existing roadways on the site. Niches throughout the plan create moments of pseudo-enclosure for refuge and extrospection.

The transition detail is used to guide movement from one spatial condition to the another. At the accommodation units the typologies come together at a smaller scale. The production detail serves as a light well rather than a heat stack and cooling is achieved through passive ventilation facilitated with a thinner building depth. Thermal massing and shading further contribute to thermal comfort.

Water catchment is accounted for at the accommodation units and photovoltaic panels account for energy loads. Passive ventilation aims to cool the spaces and thermal massing aims to stabilise the interior temperature year-round. This site benefits from its proximity to infrastructure and can therefore rely on the municipal sewer connection for sewage removal.

Arrival pavilion genealogy

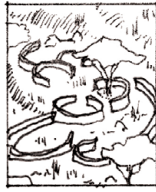
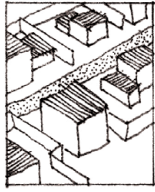

+

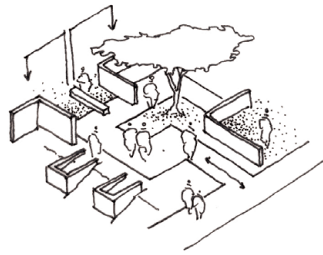

+

Programme as relationship

Textual study

Model translation



+



+



Lessons from site

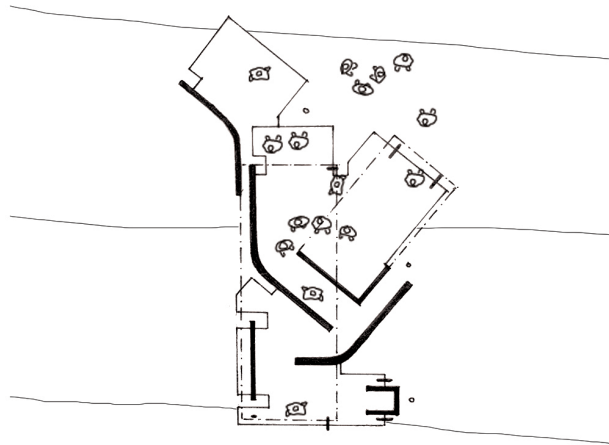
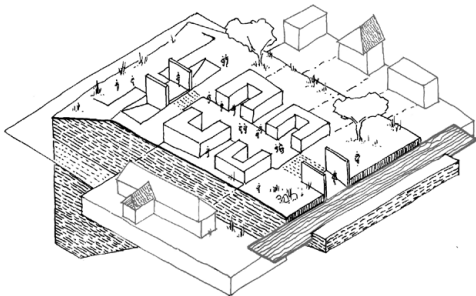

Consolidated programme concept

Plan as concept

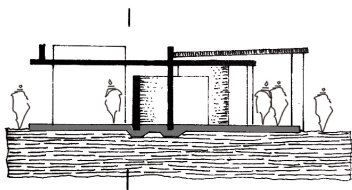

Section as concept

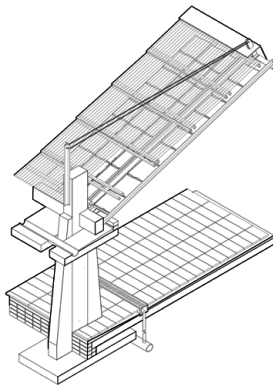

Design iteration

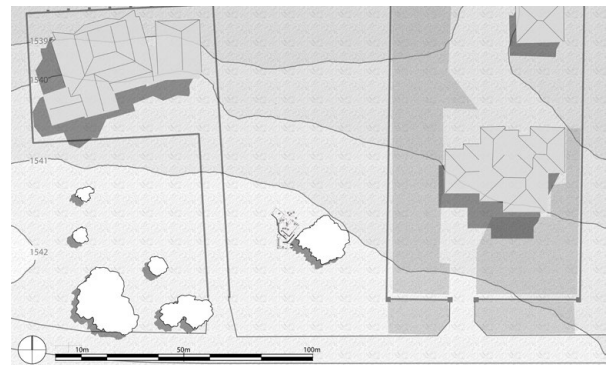

Site placement ▶ Plan resolution

Figure 91: The figures above combine to form a genealogy of the arrival pavilion, showing its development (Author, 2021).



Figure 92: Site plan of the arrival pavilion depicting thresholds and accommodation units. A service delivery road on the western side links to existing dirt roads on the site. As a threshold between the suburbs and ruin landscape, the various components are placed in relation to the geometry of the surroundings as a means of connecting the two entities (Author, 2021).

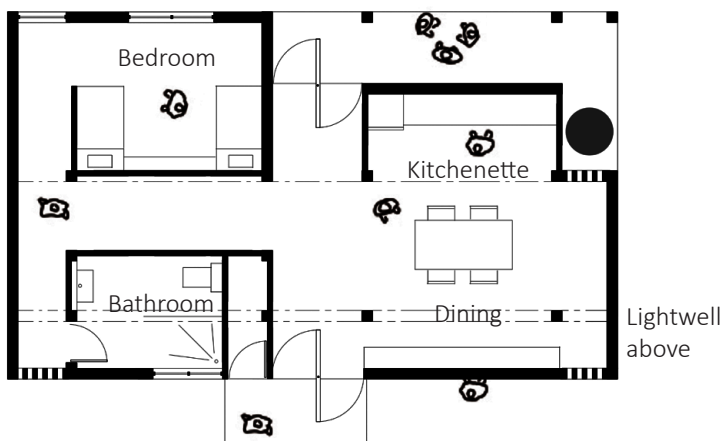

Figure 93: A plan of the basic accommodation unit, with a bedroom, bathroom and kitchenette (Author, 2021).

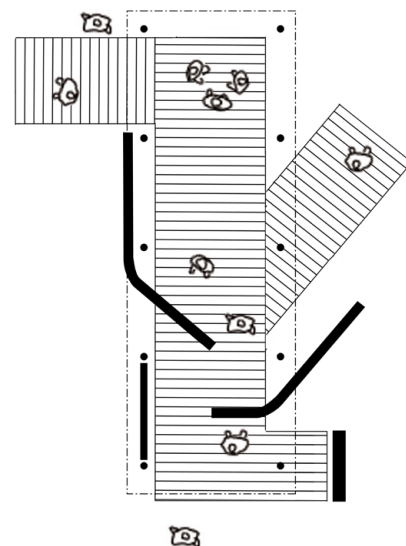

Figure 94: The initial threshold guides movement between walls with space for the display of information and images (Author, 2021).

16.2. Mediation node

The main axis of the building is a wall in line with an existing road and tilted to the east by 15° to ensure efficient daylighting and prevent excess solar heat gain. The wall has been perforated with programme to indicate shared use of the land. It may be approached from the northern landowner's side and the southern suburban which looks up at the ruins.

The mediation node serves as a stage for discussion between current landowners and the new heritage priority of this site. Agreements must be reached and terms of use determined. This building will serve as both precedent and meeting hall for this kind of discussion, with the hope that such a programme can occur throughout South Africa. Overtime, its use can be adapted to host events and cater for community gatherings.

The site slopes down slightly to the north with the gathering hall imbedded into the earth. This space sets the stage for cooperation going forth and has its founding in the meaningfulness of the landscape. It is therefore treated as part of the landscape with the adjacent structures sticking to the raised floor notion. The southern elevation of the building is lined with the observation detail in the form of a passage with vistas to direct focus towards the ruin landscape beyond. Along the observation detail, instances of the production typology are placed as offices, ablutions and storage, all with light wells for adequate daylighting.

Photovoltaic panels provide the energy needed for the programmes to function and a water connection can be taken from the northern municipal line to supplement harvested rain water.

Mediation node genealogy

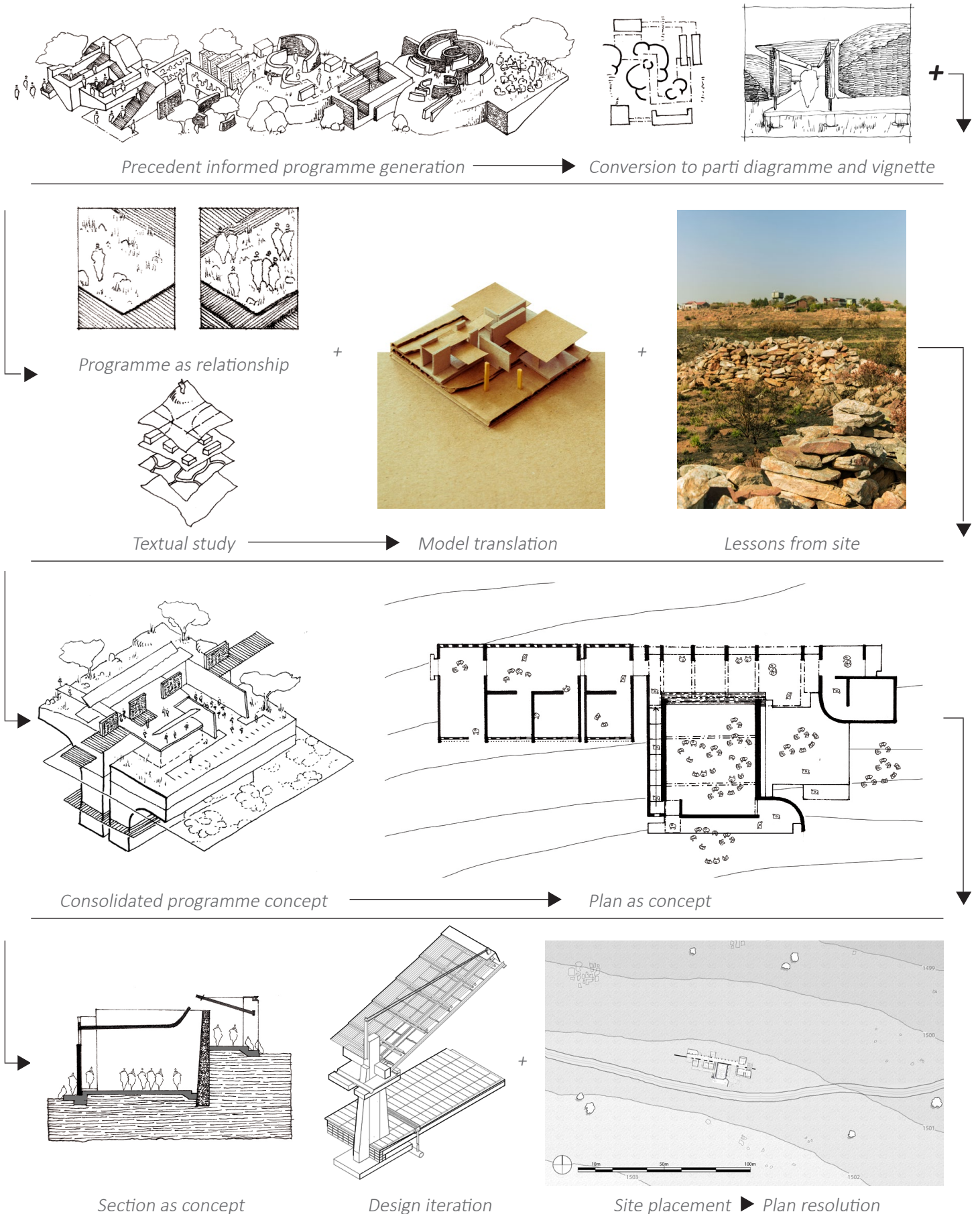

Figure 95: The figures above combine to form a genealogy of the mediation node, showing its development (Author, 2021).

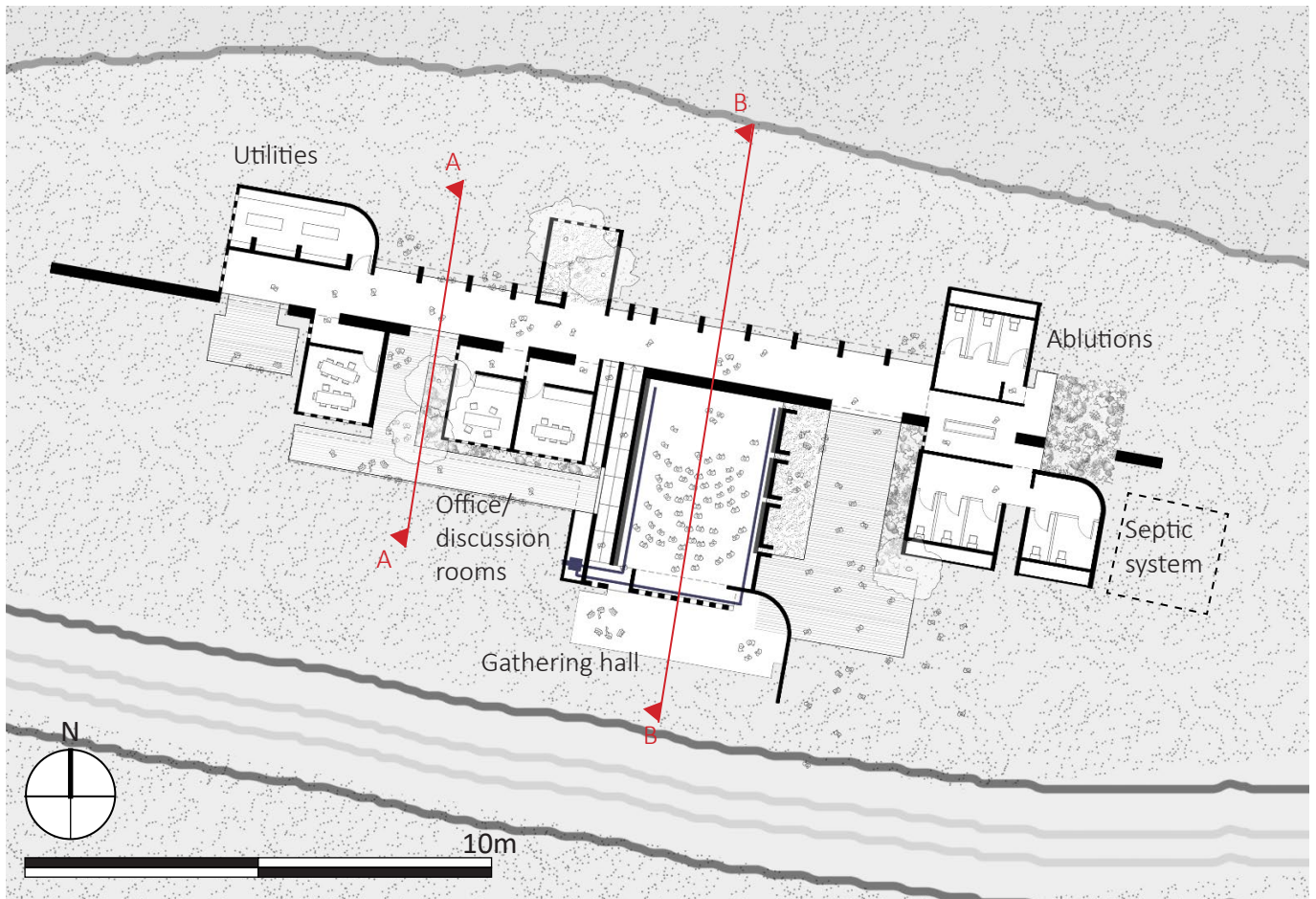

Figure 96: Initial plan drawing of the mediation node (Author, 2021).

Figure 97: Section through the gathering space that leads out to a view of the landscape. A space for lingering during mediation processes and discussions (Author, 2021).

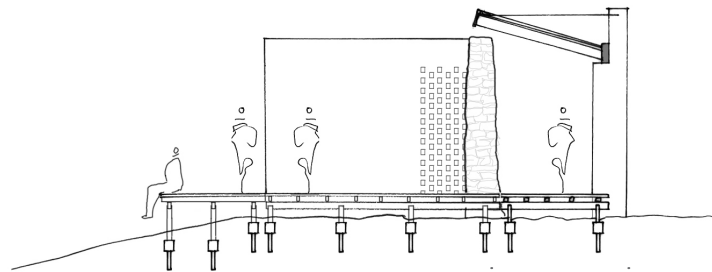
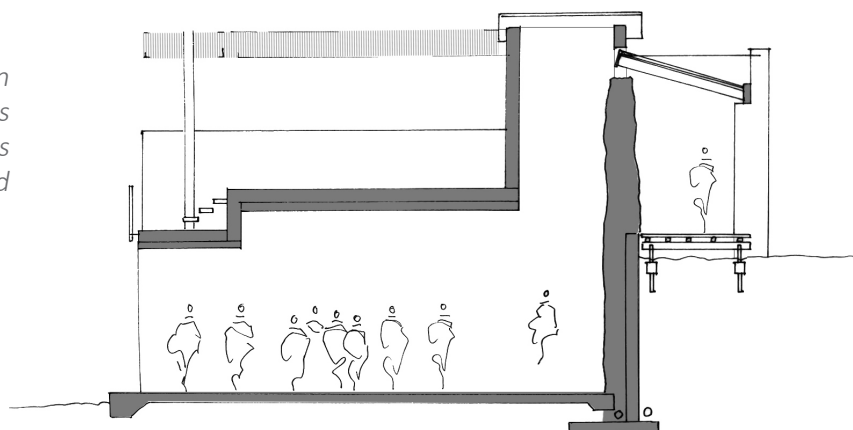

Figure 98: Section through the main hall where community discussions happen and the topic of land use is decided upon by the landowner and heritage practitioners (Author, 2021).









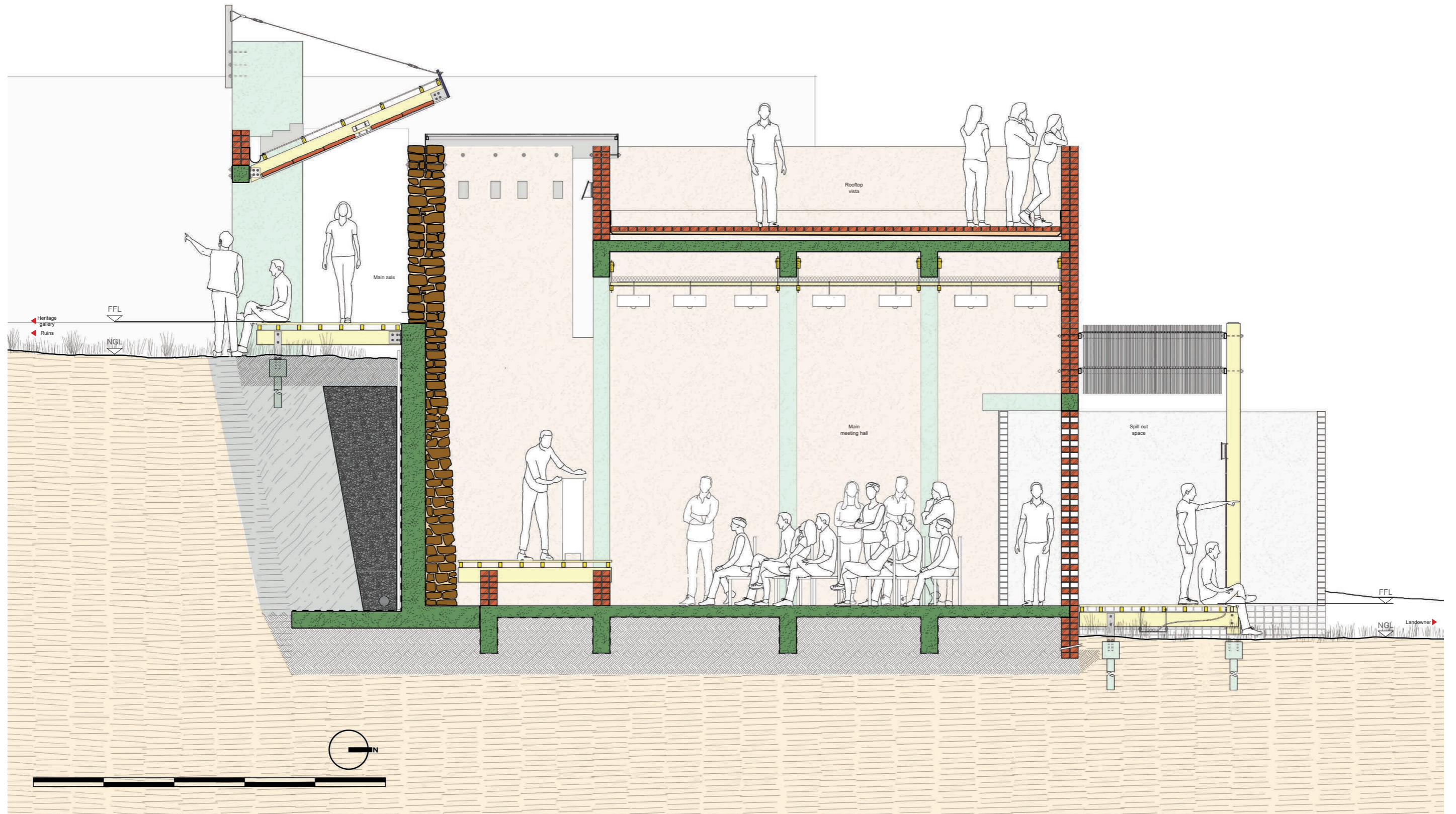

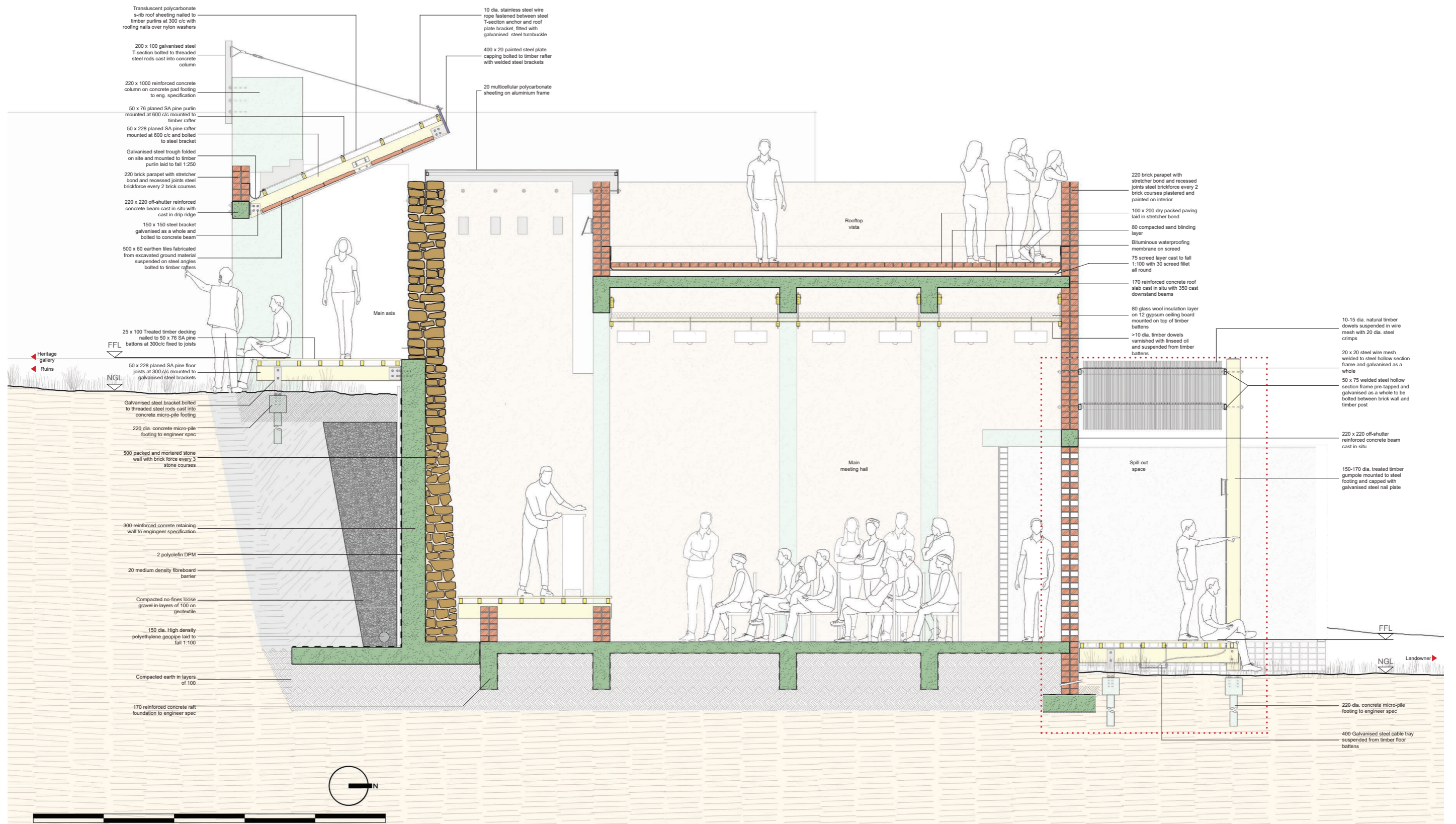

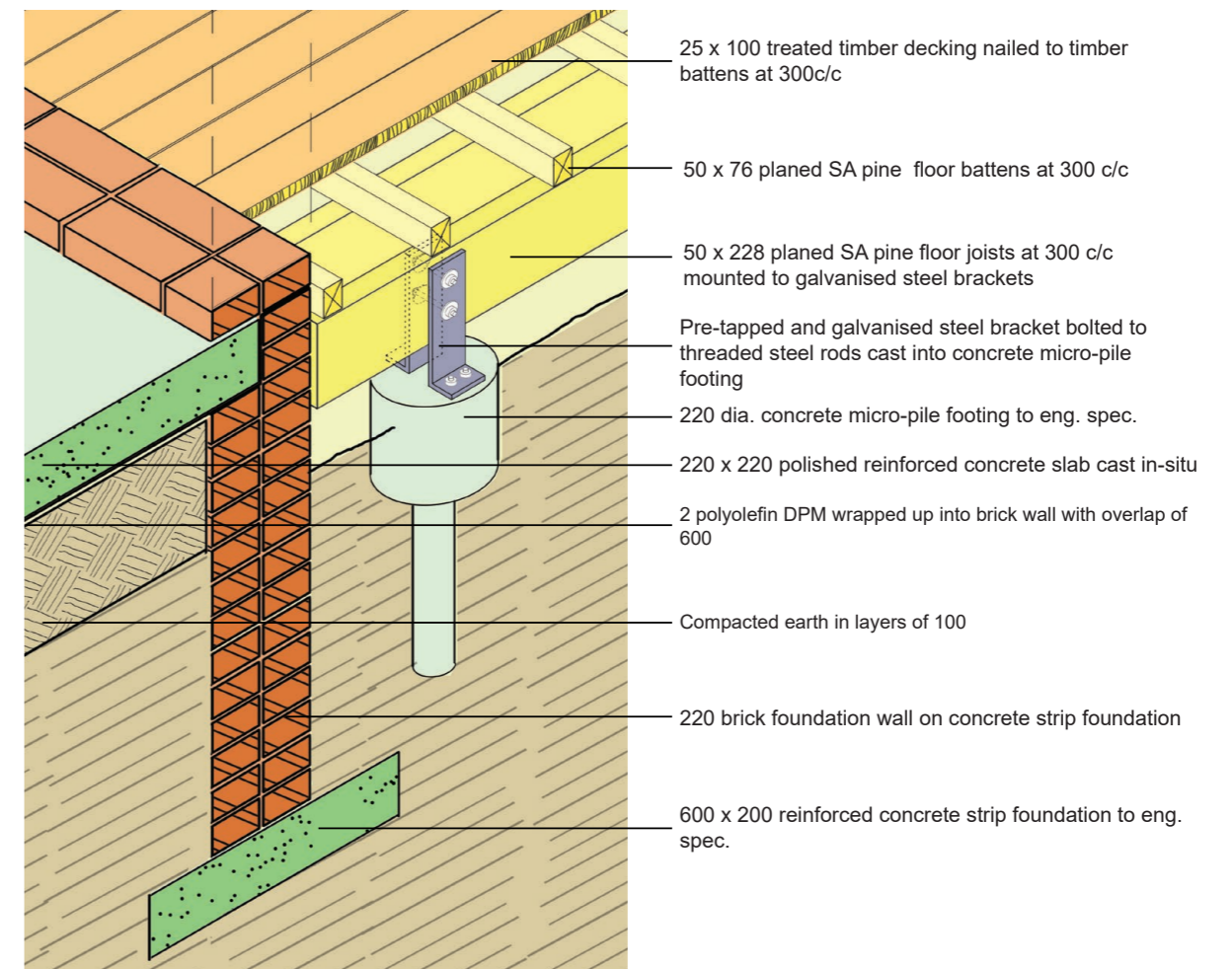
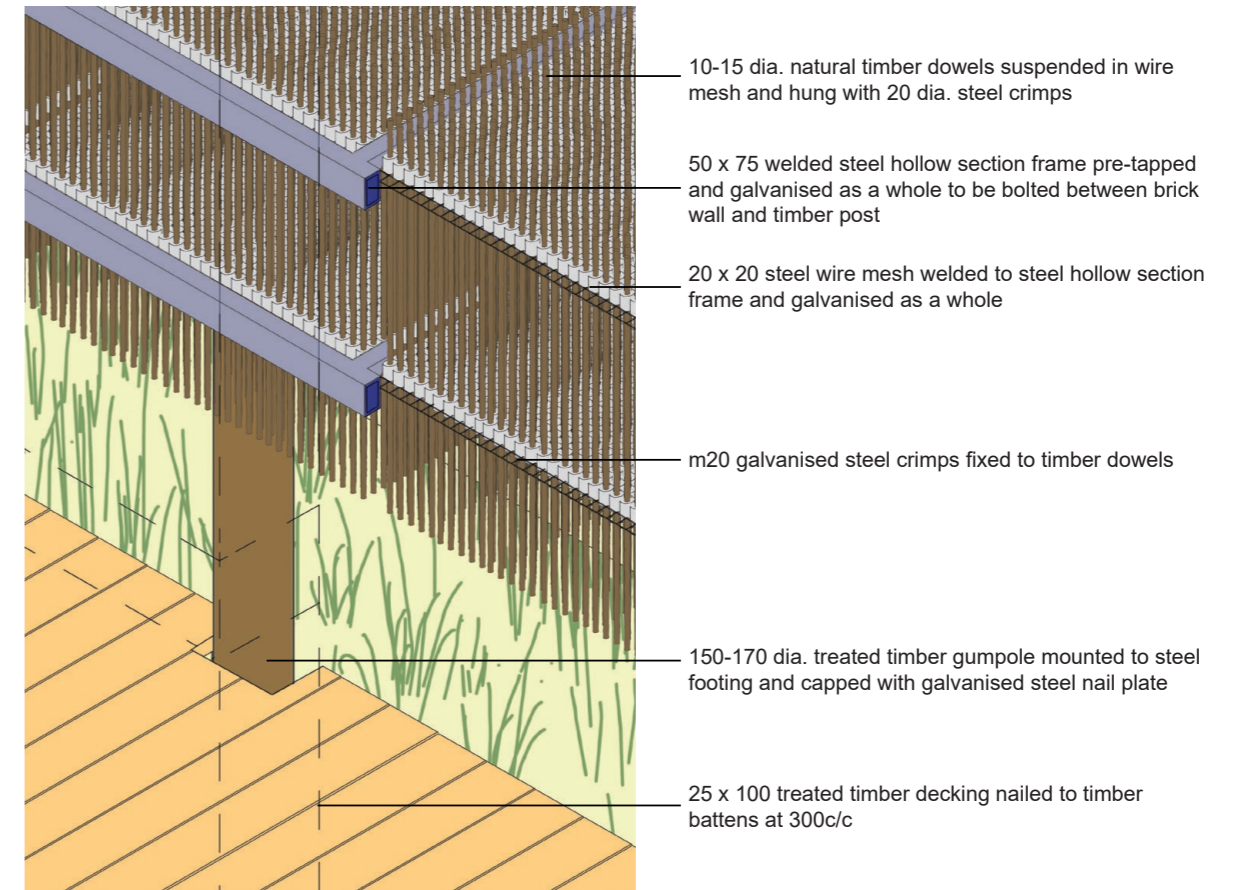
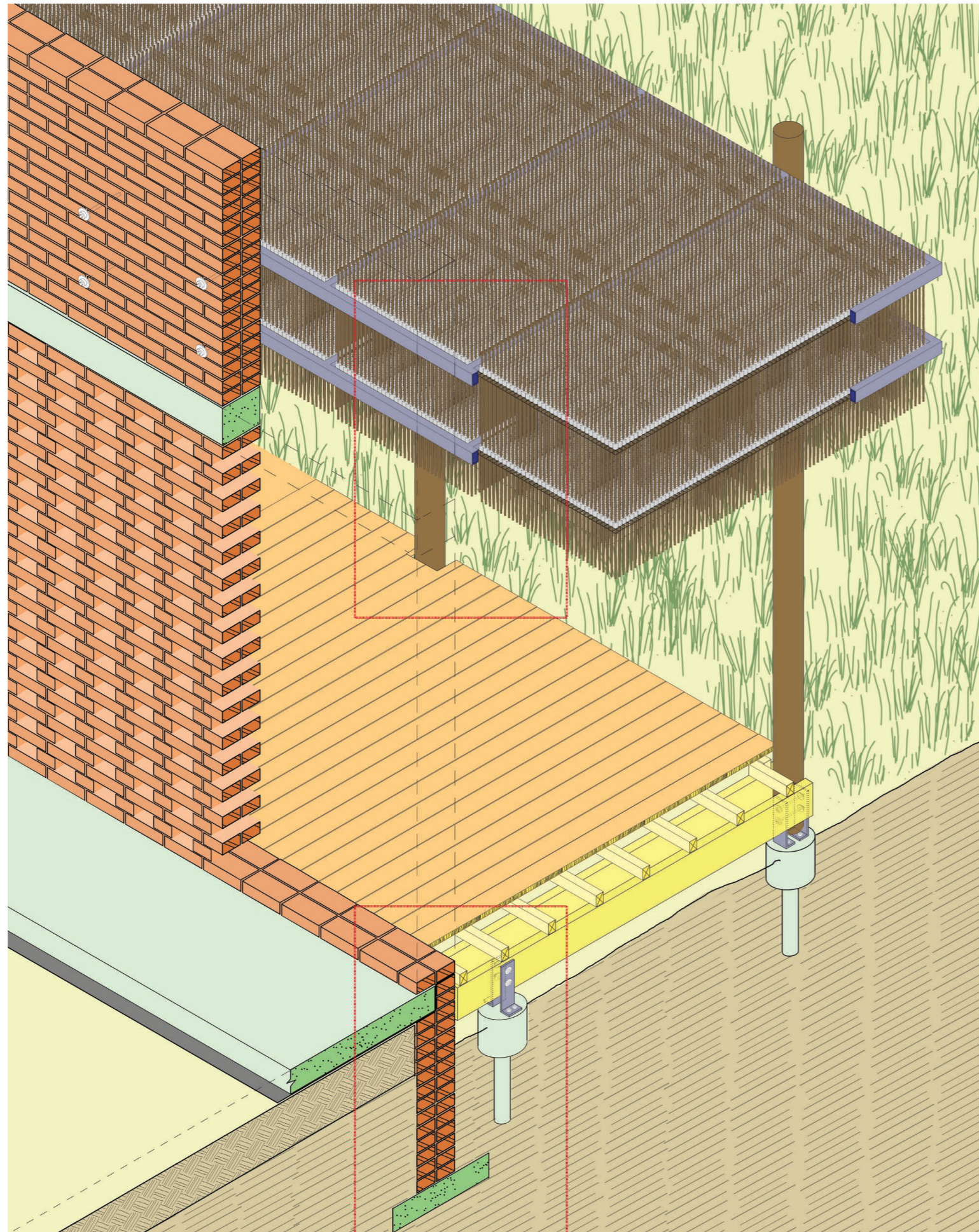

16.3. Heritage gallery

The building is situated on a slight clearing amidst a rocky area in a centralised proximity to the surrounding ruins. The orientation is bent to offer visual panoramas of the ruins from this high vantage point. Deep northern facades and overhangs prevent excess solar heat gain on the northern facing elevation. The western section relies more heavily on passive ventilation strategies to provide coolth during the harsh heat of dusk.

The heritage gallery will serve as a space for artefact creation, discussion and event planning. Where support functions act as mounds between which the main programme is strung. Here, significant members of the community can discuss the manner in which artefactual data is presented to the public. Contemporary artists can join a residency type programme with a focus on producing art within this field. The public is not exposed to the production process which is deemed private and belonging to the makers.

Studios can be shaped to accommodate multiple activities- allowing diverse artistic expressions. Individual display niches highlight the importance of works and offer space for information display- prioritising a read understanding of heritage.

The section reveals the manner in which the typical details are combined. These indicate spaces of production facing north, observation facing south and transition in the centre connecting the two. The walls either side of the central passage open to allow ease of curation between the production spaces and display spaces.

Warmer air generated in the productive spaces rises and escapes out of heat stacks, while cool air, created using a wetted mesh, falls and cools the spaces. Photovoltaic panels can be accommodated on the roof of production spaces at each building to provide electricity. Passive ventilation plays a minor role along with shading and thermal massing to create a cooler ambient condition in the building.

Heritage gallery genealogy

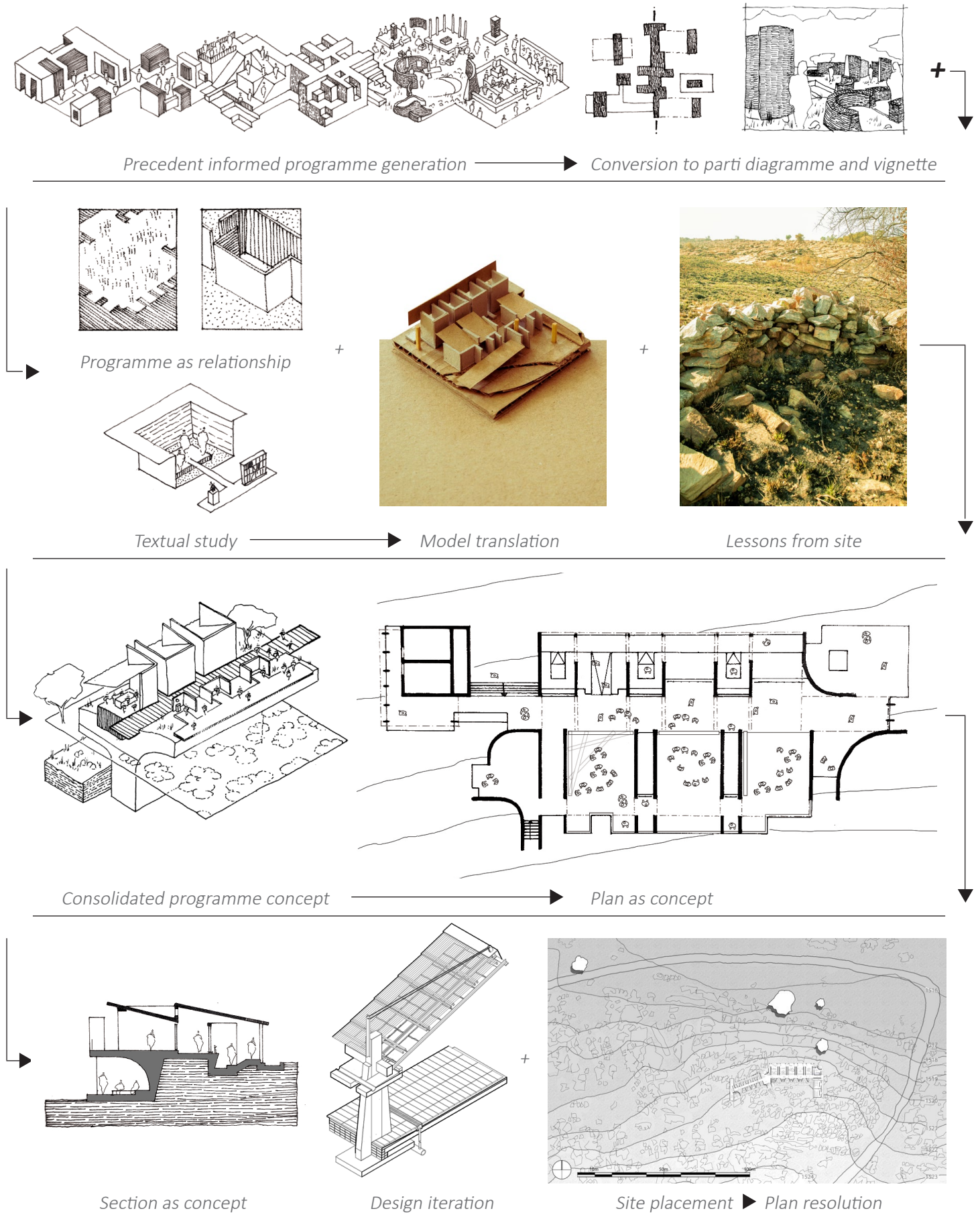

Figure 105: The figures above combine to form a genealogy of the heritage gallery, showing its development (Author, 2021).

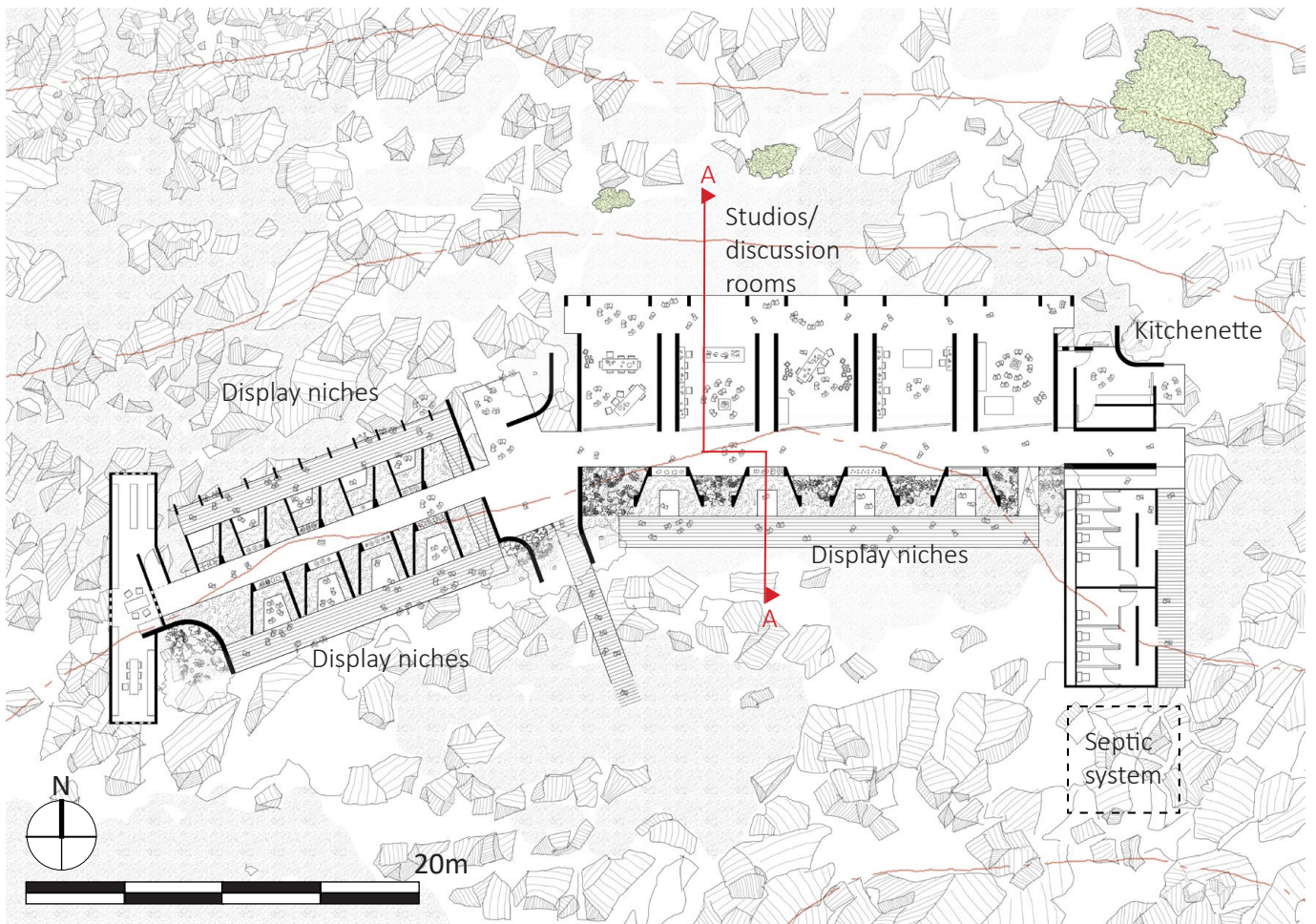

Figure 106: Initial plan drawing of the heritage gallery (Author, 2021).

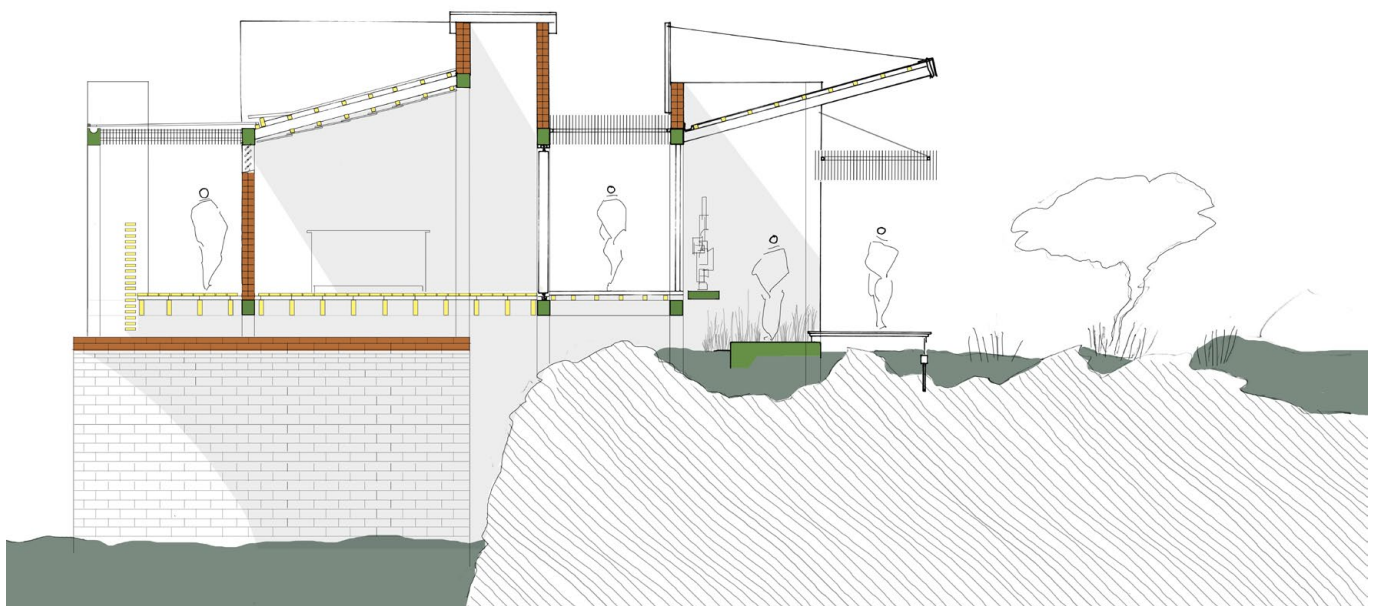
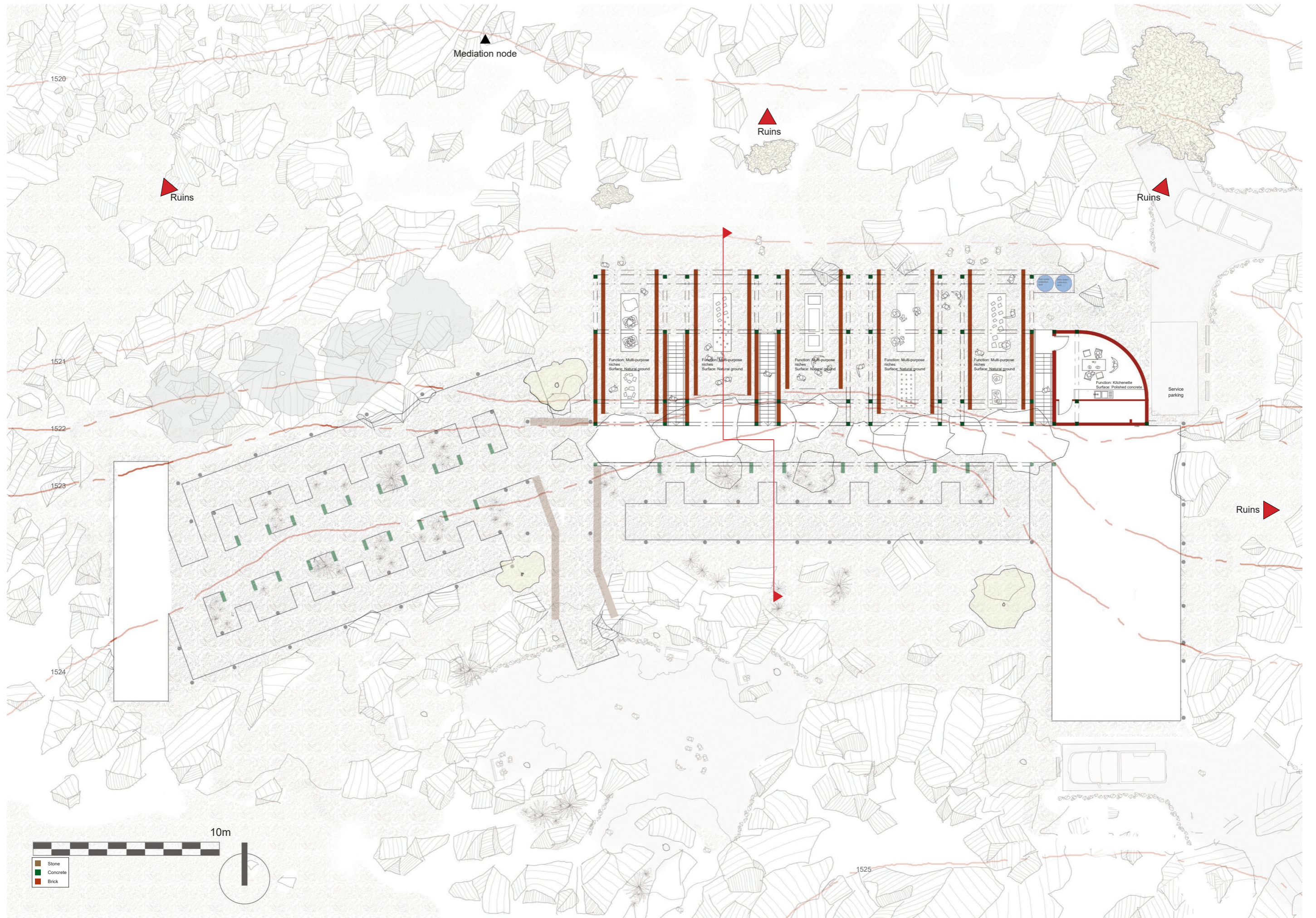
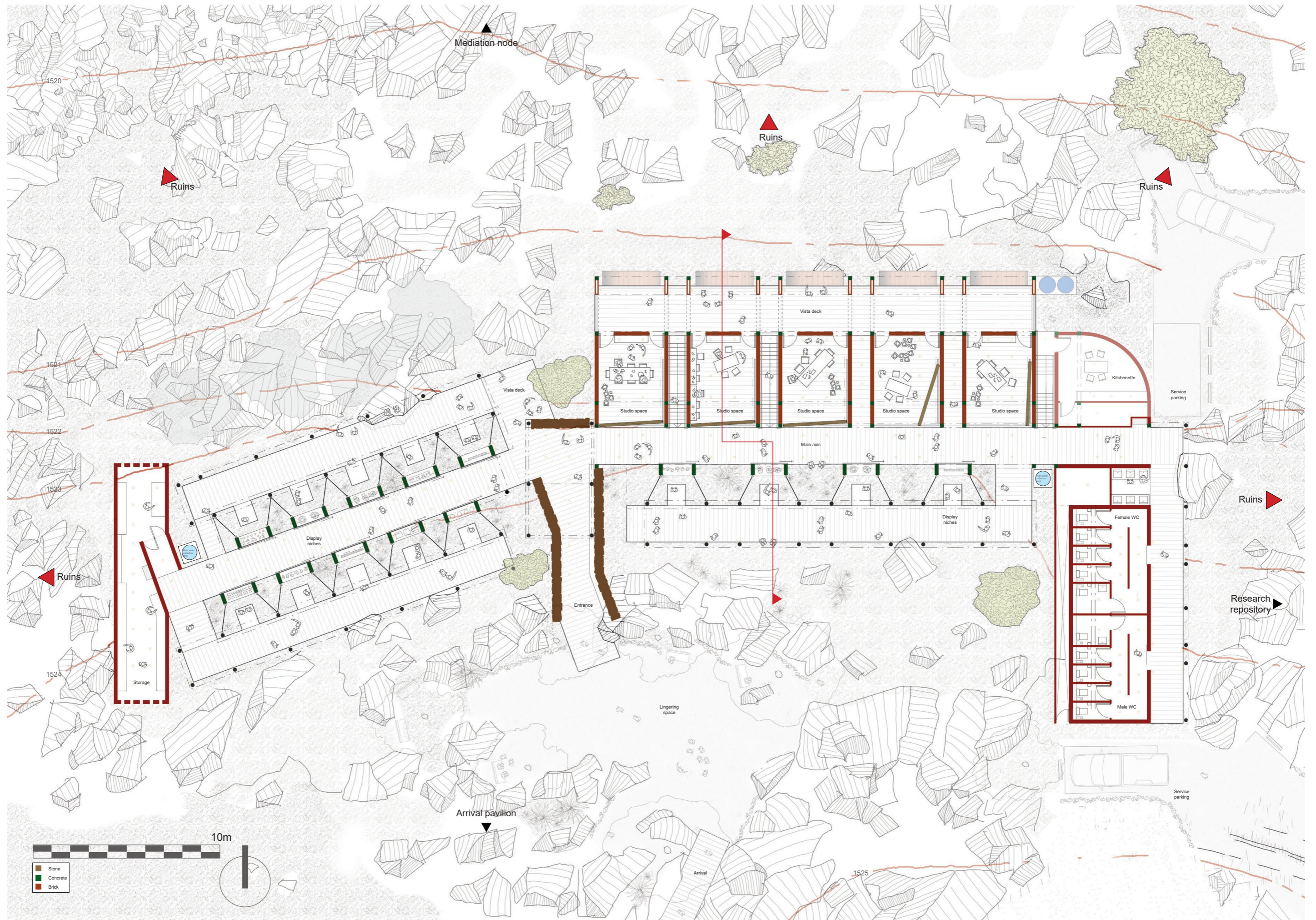
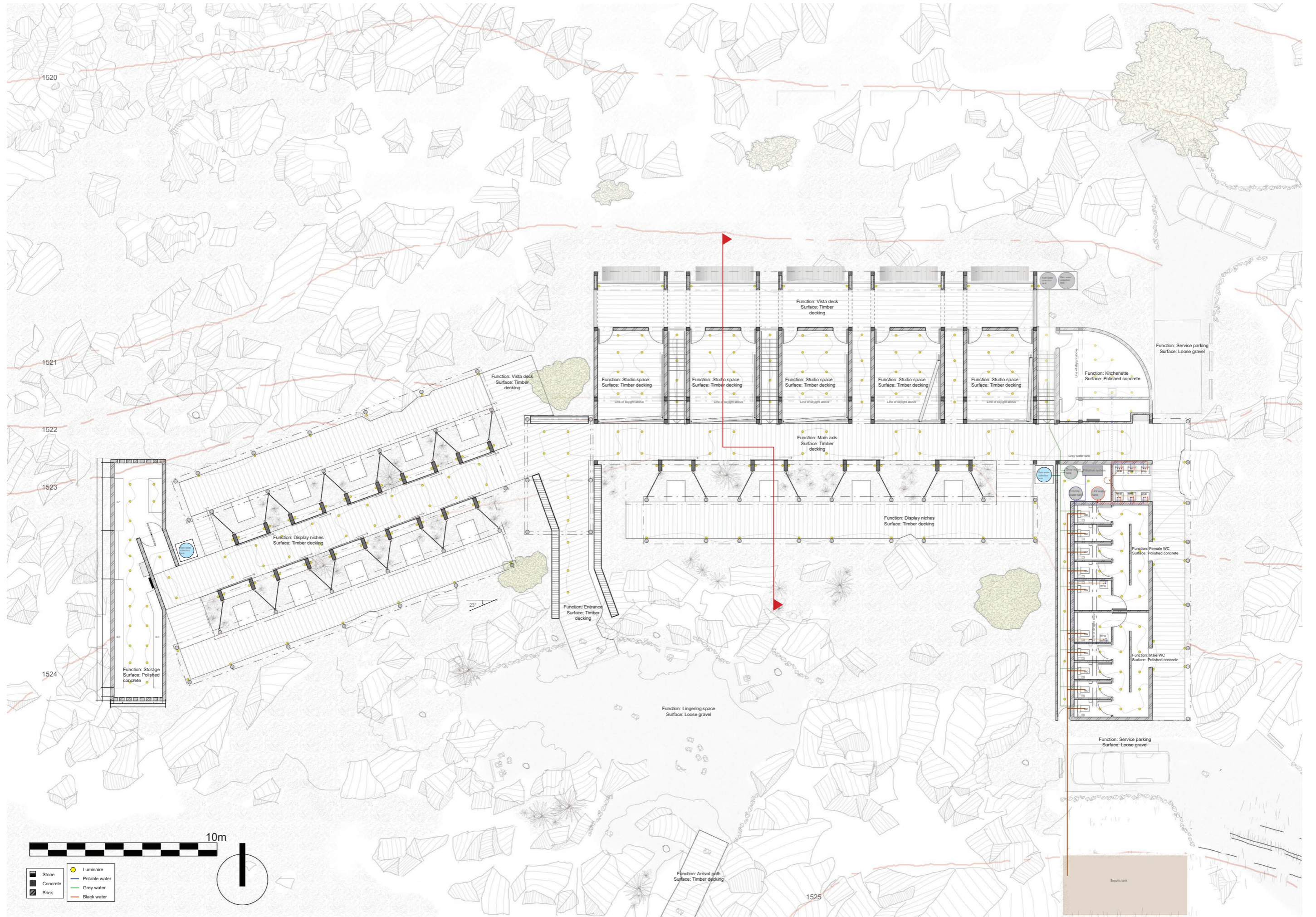
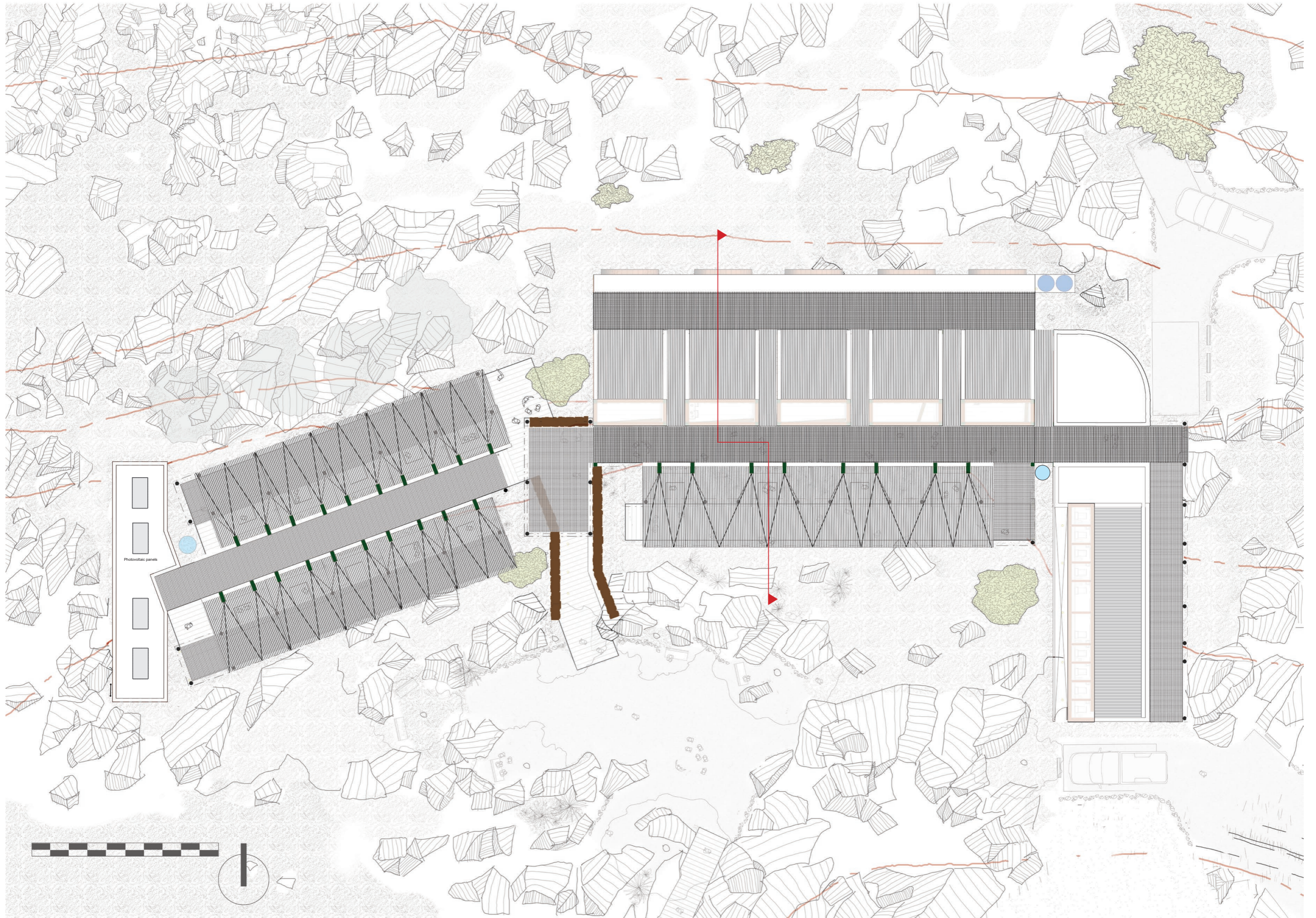

Figure 107: Section through the heritage gallery showing the split relationship between a more sacred production process in the studios on the left and the publicly accessible display niches on the right. This separation protects the authorship of the practitioners involved and offers agency to members of the Ndebele language group when deciding what aspects of their material culture pertaining to the site can be displayed to the public. Additional exhibition spaces sit in close communion with the landscape on the lower level. Large-scale installations can take place in these niches (Author, 2021).









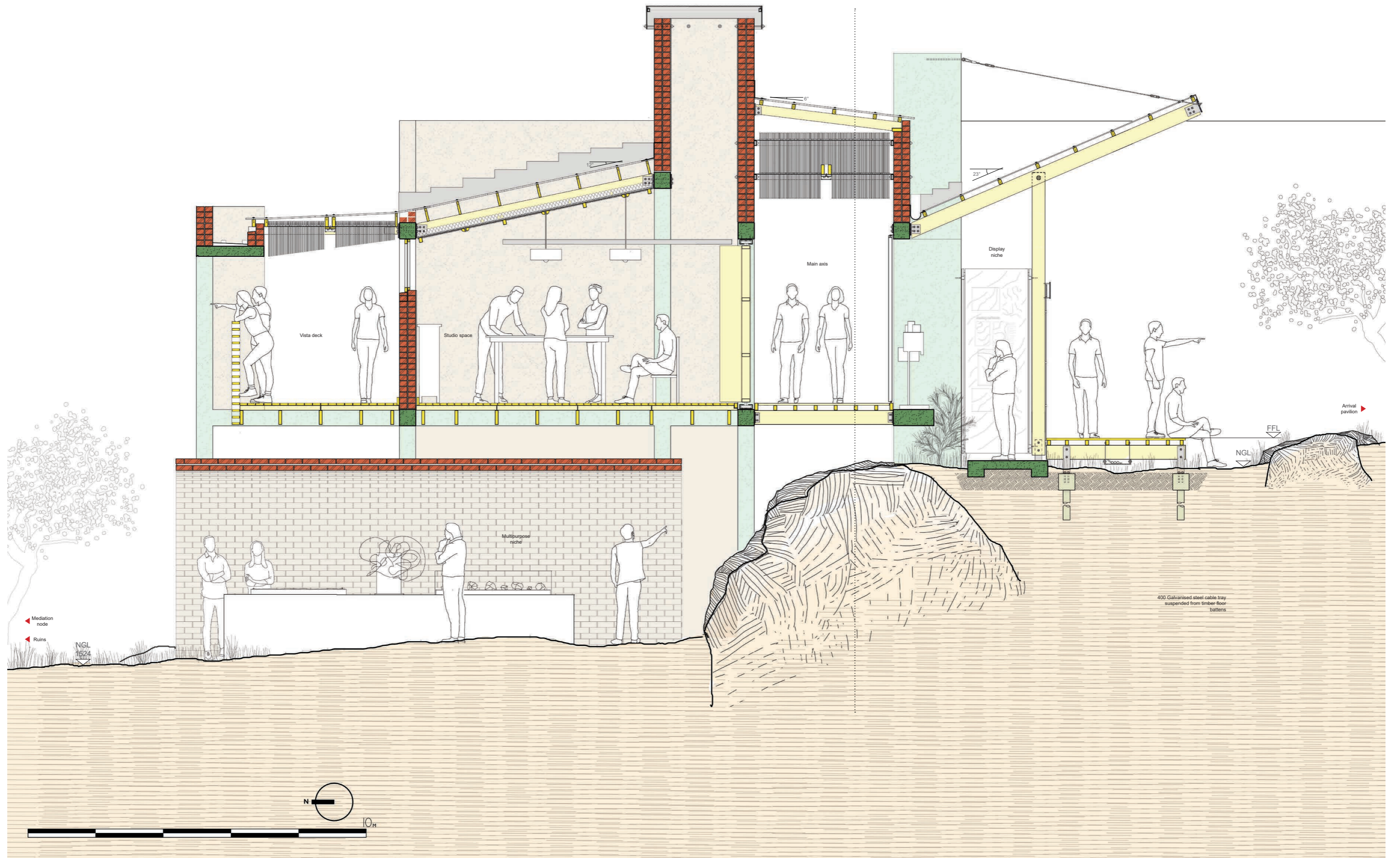

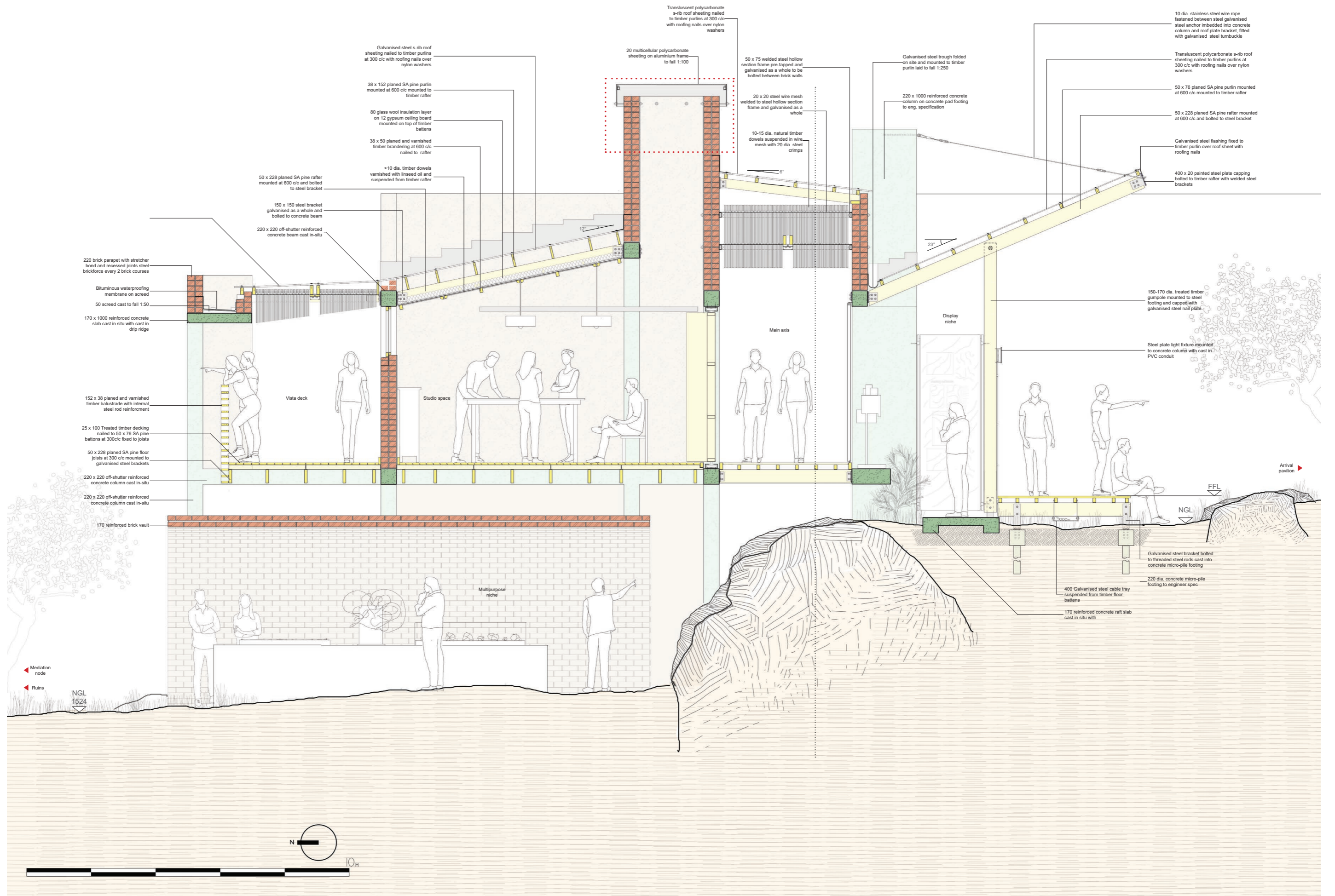

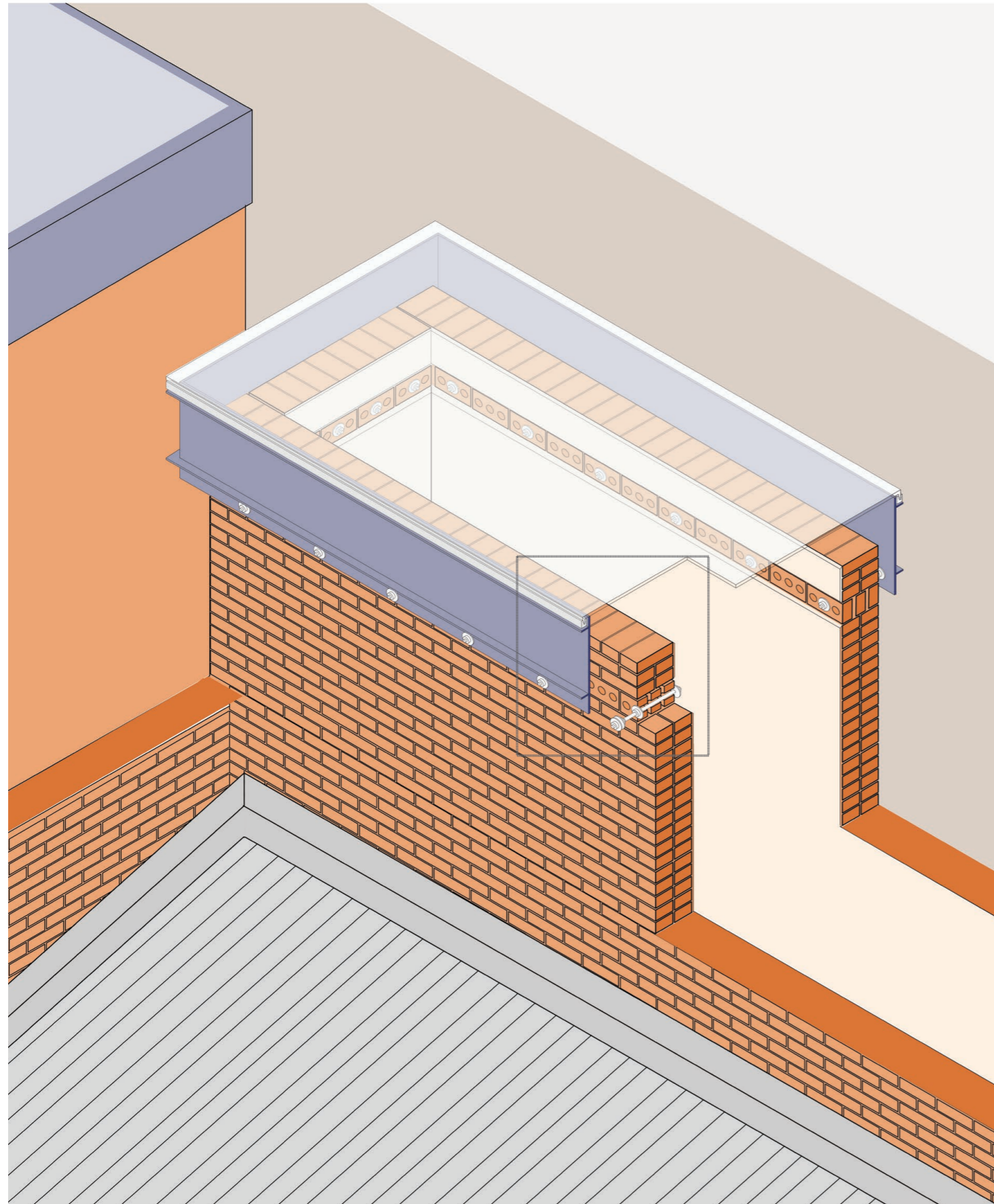

- 20 multicellular polycarbonate sheeting on aluminium frame to fall 1:100
- 50 aluminium sheeting mount screwed to steel plate over polyurethane expansion layer
- 20 painted cement and sand plaster over single brick parapet wall on inte
- 220 brick parapet with stretcher bond and recessed joints steel brickforce every 2 brick courses plastered on interior
- 4 x 600 steel plate skylight frame with 40 flanges welded on and galvanised as a whole mounted to brick parapet on threaded steel rods
- 110 brick on edge for one course
- m30 galvanised bolt on threaded steel rod over steel and nylon washers through brick frogs and on both sides of brick parapet tightened
- m40 steel washer over nylon washer
- m30 galvanised bolt on threaded steel rod through steel skylight frame tightened to fix plate in place

16.4. Navigation platforms

These platforms are positioned throughout the site to create a network of visually accessible wayfinding markers. Each instance has its own plan, where stone walls are used to direct movement towards the location of the nearest ruins. These are exterior structures and offer repose in the form of shade from the sun, but do not require further protection to the same extent as interior spaces.

Over time, the goal is that intuitive pathways will form on the landscape between these platforms and the other buildings on the site. Together, the ruins, landscape and contemporary living heritage programmes will be stitched together by the product of activity. Such pathways that develop over time negate the need for initial invasive stretches of long boardwalk.

The transition typology, both the timber lath mattress shading device and decking detail, is used to create minimally penetrative platforms with shade shaped by materials bearing the semblance of the landscape.

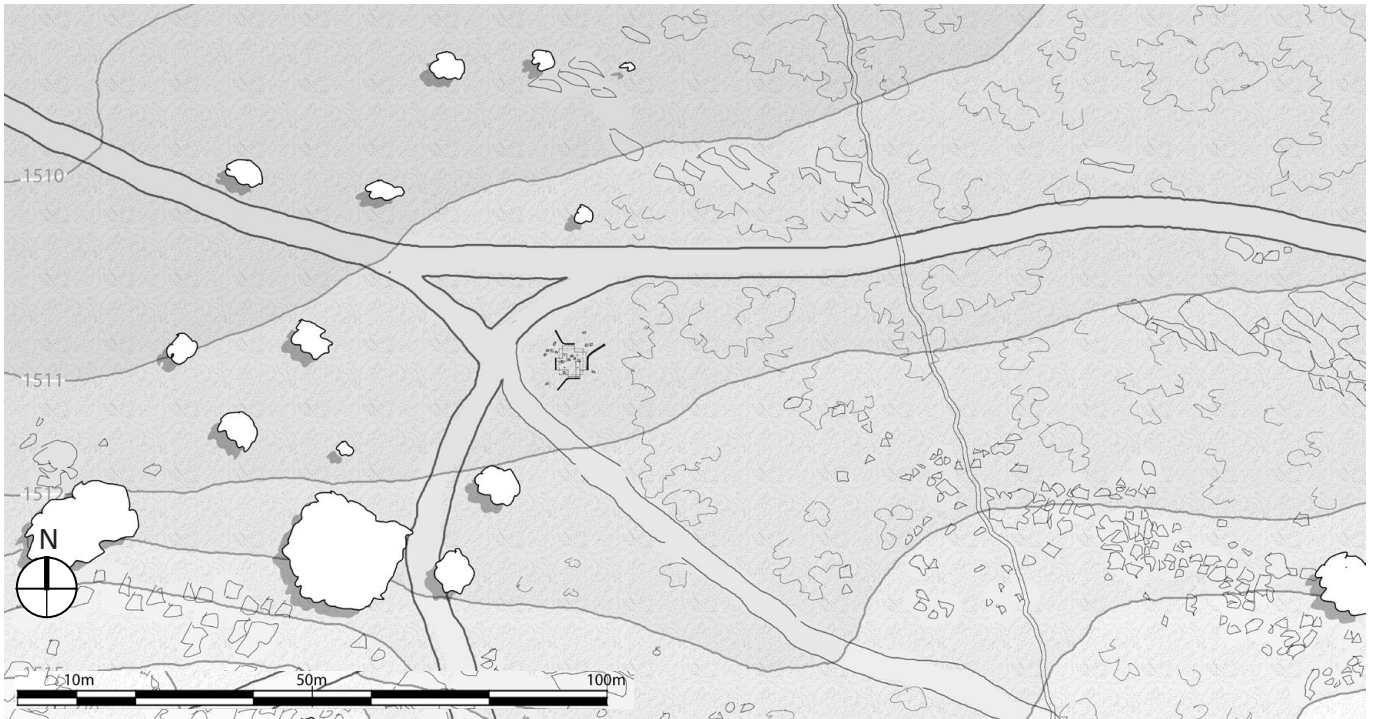

Figure 115: Plan drawing of a navigation platform. This one sits in a large network that extends visual accessibility across the site. Wayfinding is prioritised and new foot paths will form over time (Author, 2021).

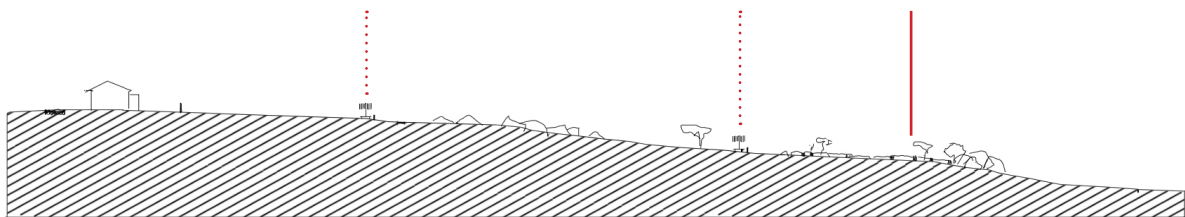

Figure 116: Landscape section diagram showing the scale of the navigation platforms in relation to the ruins and suburbs.

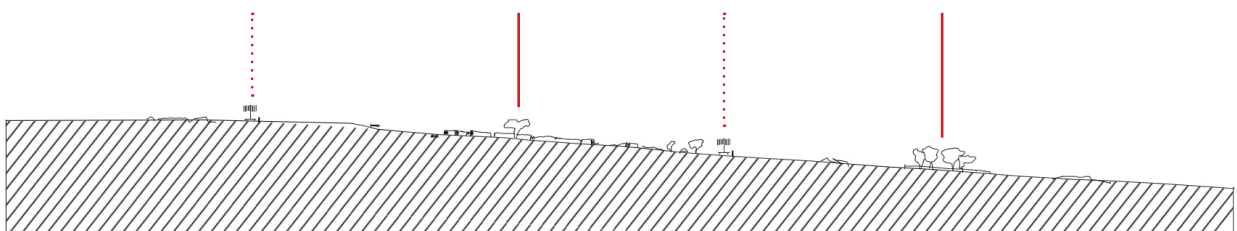
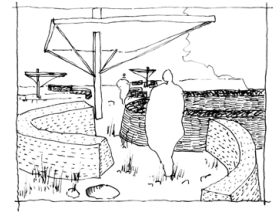
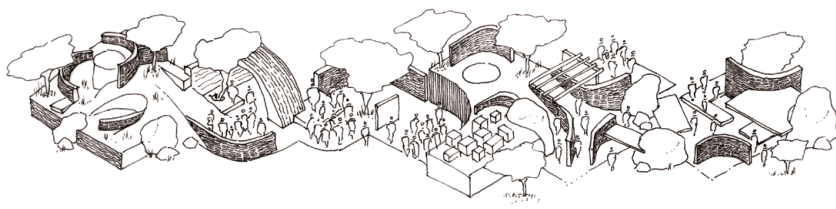

Figure 117: Landscape section diagram showing the navigation platforms as wayfinding devices to aid in ruin visualisation.

Navigation platforms genealogy



Precedent informed programme generation

Conversion to parti diagramme and vignette

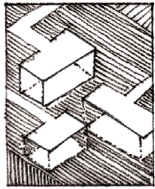

Programme as relationship

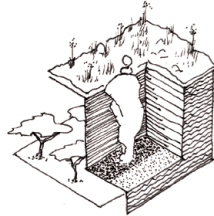
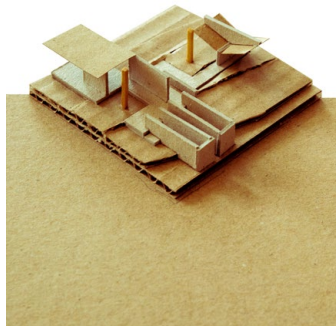

Textual study

Model translation

Lessons from site

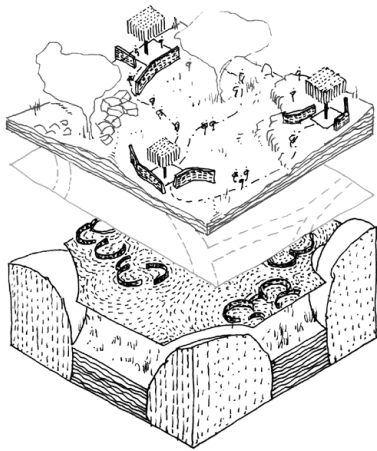

Consolidated programme concept

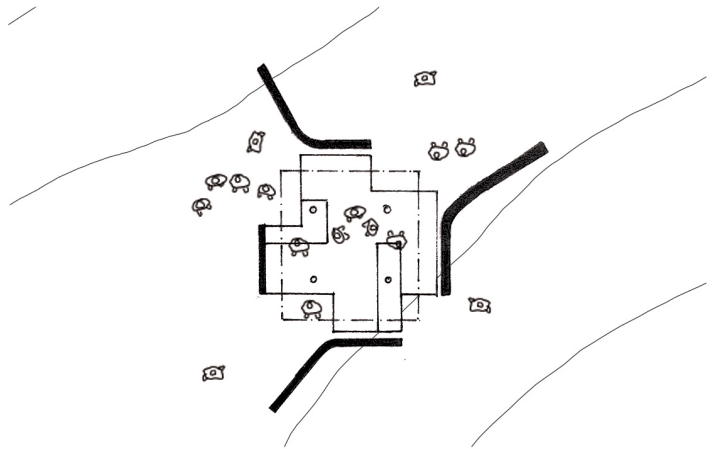

Plan as concept

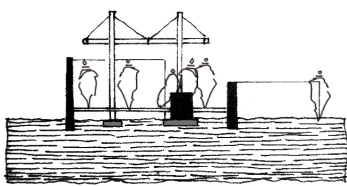

Section as concept

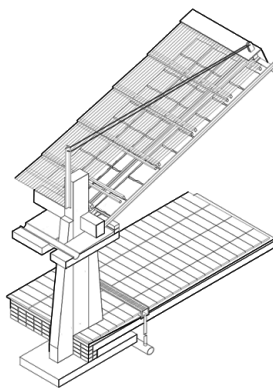

Design iteration

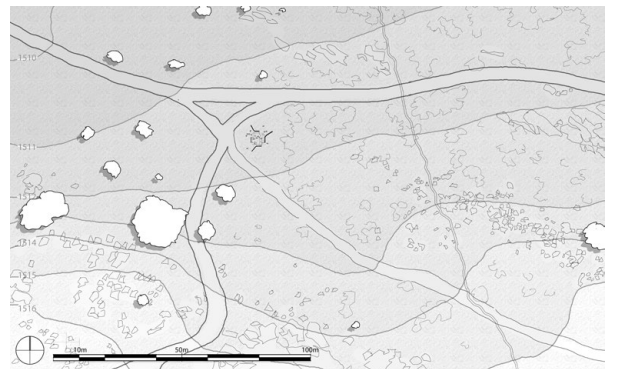

Site placement ▶ Plan resolution

Figure 118: The figures above combine to form a genealogy of the navigation platform, showing its development (Author, 2021).

16.5. Research repository

The research repository sits closer to the eastern periphery of the ruins with only the eastern most ruins beyond it. To imply a sense of procedural documentation, this position provides easy access to the first set of ruins to be documented, and then ease of access to the rest via an existing dirt road. Its orientation is parallel to the existing road, creating a challenge with harsh western solar heat gain. This is combatted with a bend in the plan that offers shade on the western elevation, and also with north-western trees and enclosures.

The repository intends on providing research and documentation facilities for the site, where ground material can be examined, artefacts can be documented and knowledge can be generated. Such a programme can also be a hub for similar satellite programmes at other ruin sites in the region. Universities and heritage boards can be involved in creating and disseminating this knowledge. Visitors and practitioners are offered a chance for empirical education regarding the physical composition of the site's heritage material, while also experiencing a more intangible aspect of it elsewhere on the site.

The plan is broken into two mounds of enclosed research spaces and discussion rooms with an archive in the middle. A courtyard serves as the drop-off area for excavated material that can be distributed throughout the building.

The observation detail is used in to create a semi-open-air space around the archive. The storage units contained underneath will be sealed to protect the material, while a lateral connection to the landscape is prioritised. Interior decking, while serving to minimise ground interference, also drives any stray water away. Light wells from the production detail are used to bring daylight into the research and discussion rooms.

Due to the heavy energy load of the equipment, a municipal electrical and water connection will be required. The equipment also necessitates careful temperature control; therefore, mechanical cooling will be used and the energy load will be supplemented with photovoltaic panels.

Research repository genealogy

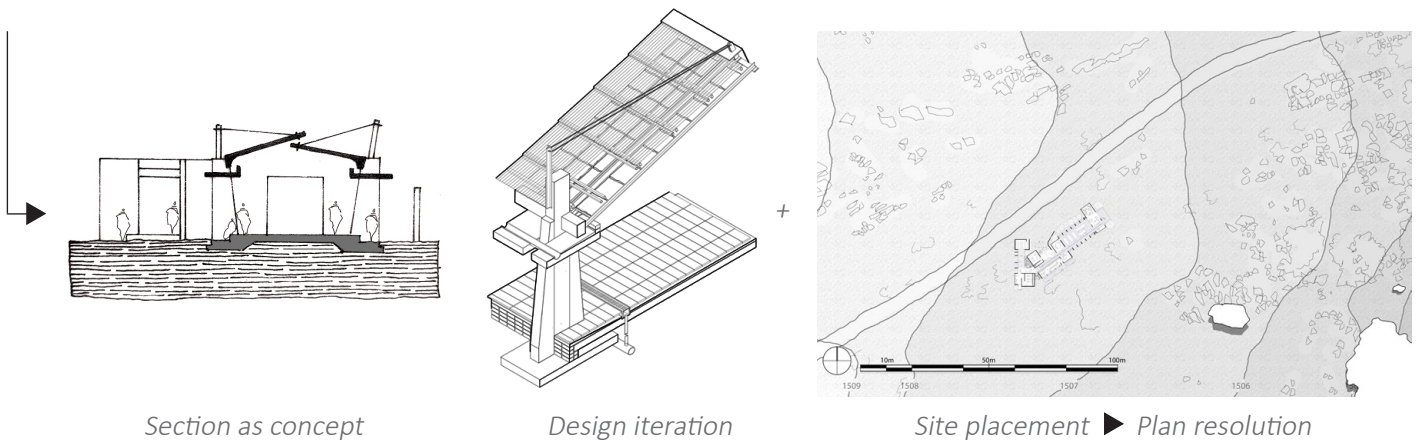
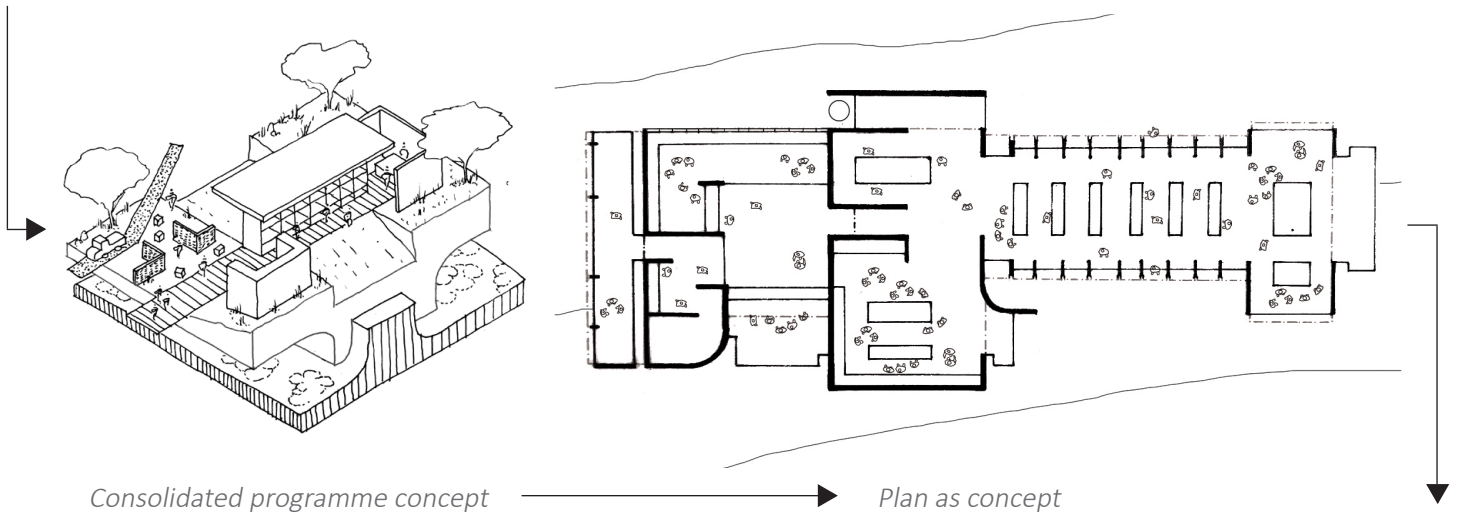
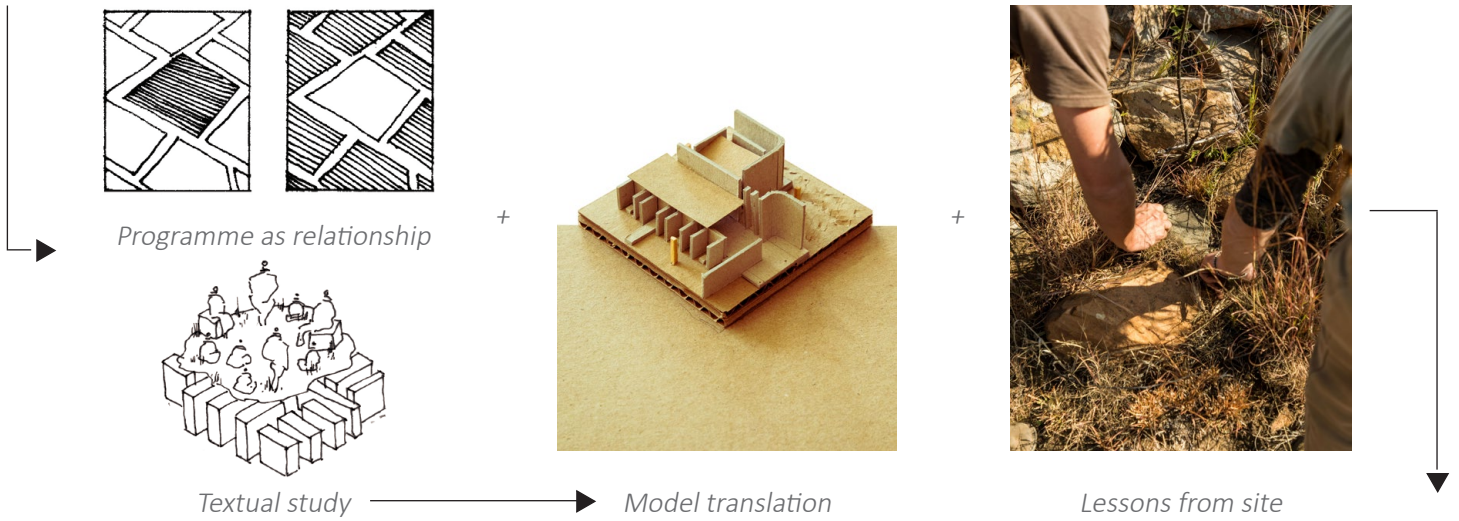
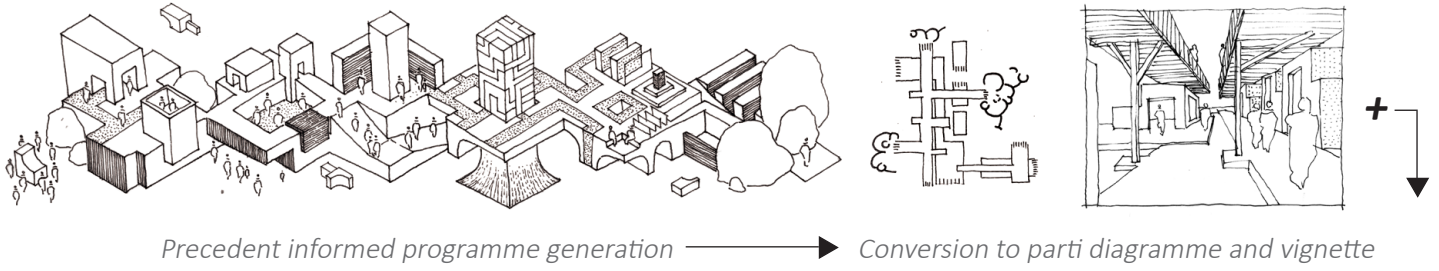

Figure 119: The figures above combine to form a genealogy of the research repository, showing its development (Author, 2021).

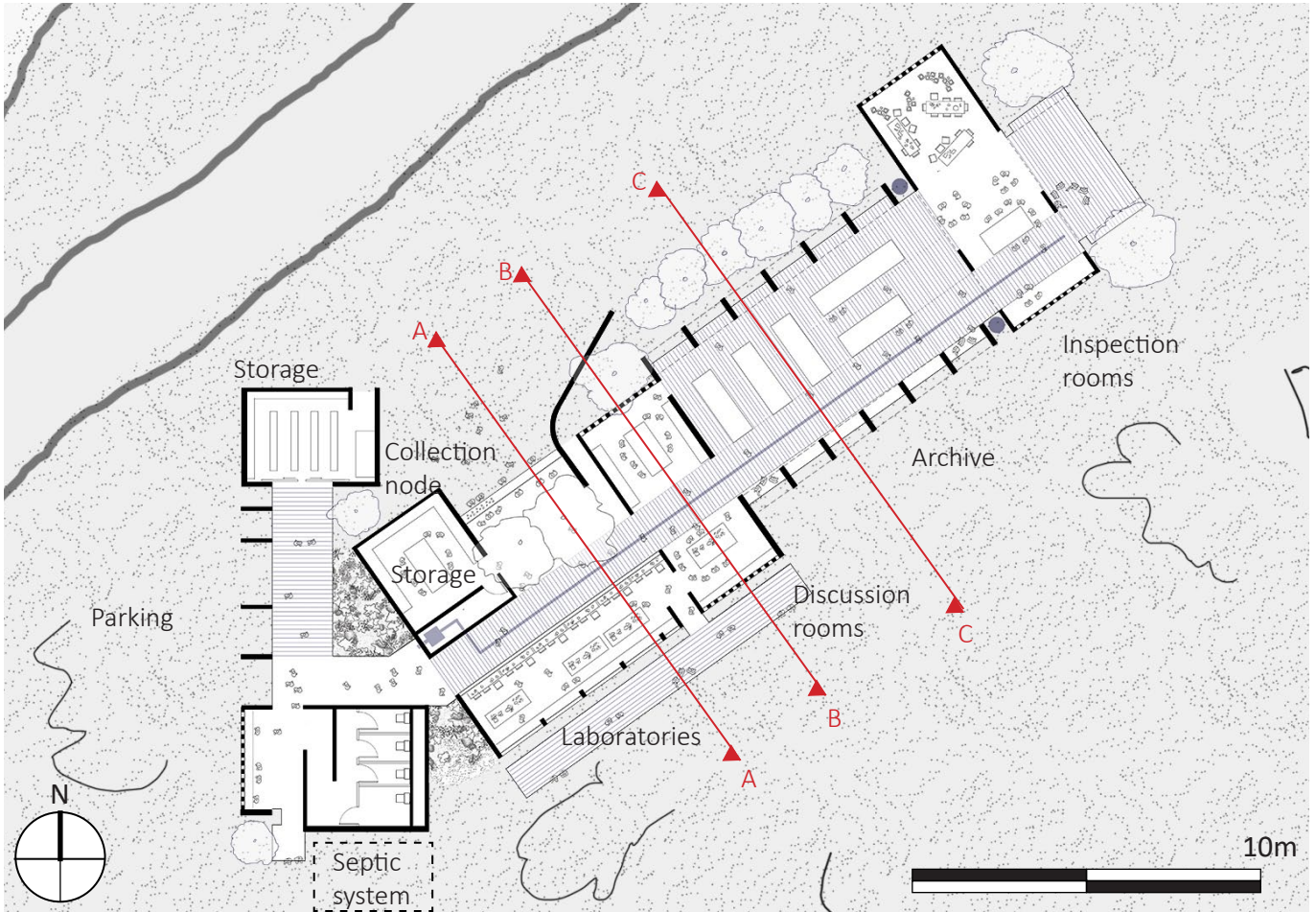

Figure 120: Initial plan drawing of the research repository (Author, 2021).

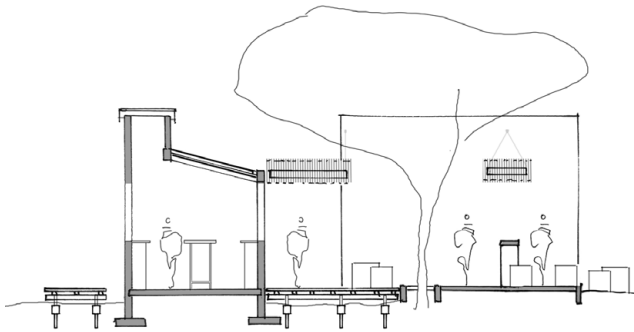

Figure 121: Section A-A as diagram through the collection where excavated heritage material is dropped off for analysis at the lab to the left (Author, 2021).

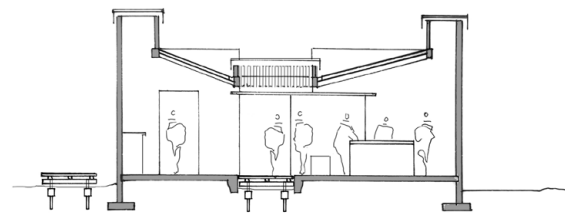

Figure 122: Section B-B as diagram through the discussion rooms where material can be analysed, debated and defined (Author, 2021).

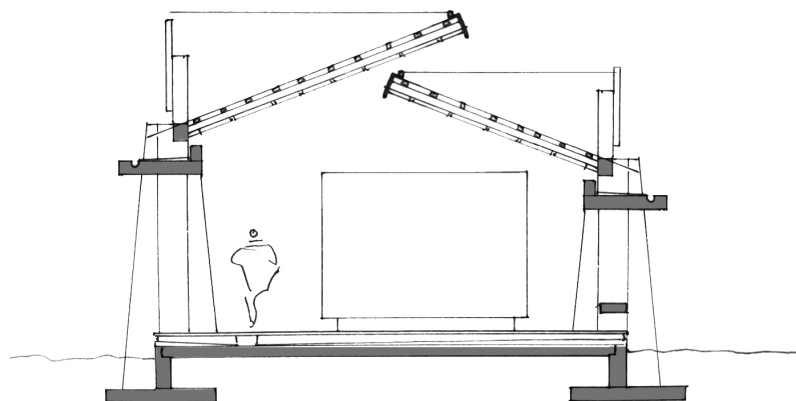
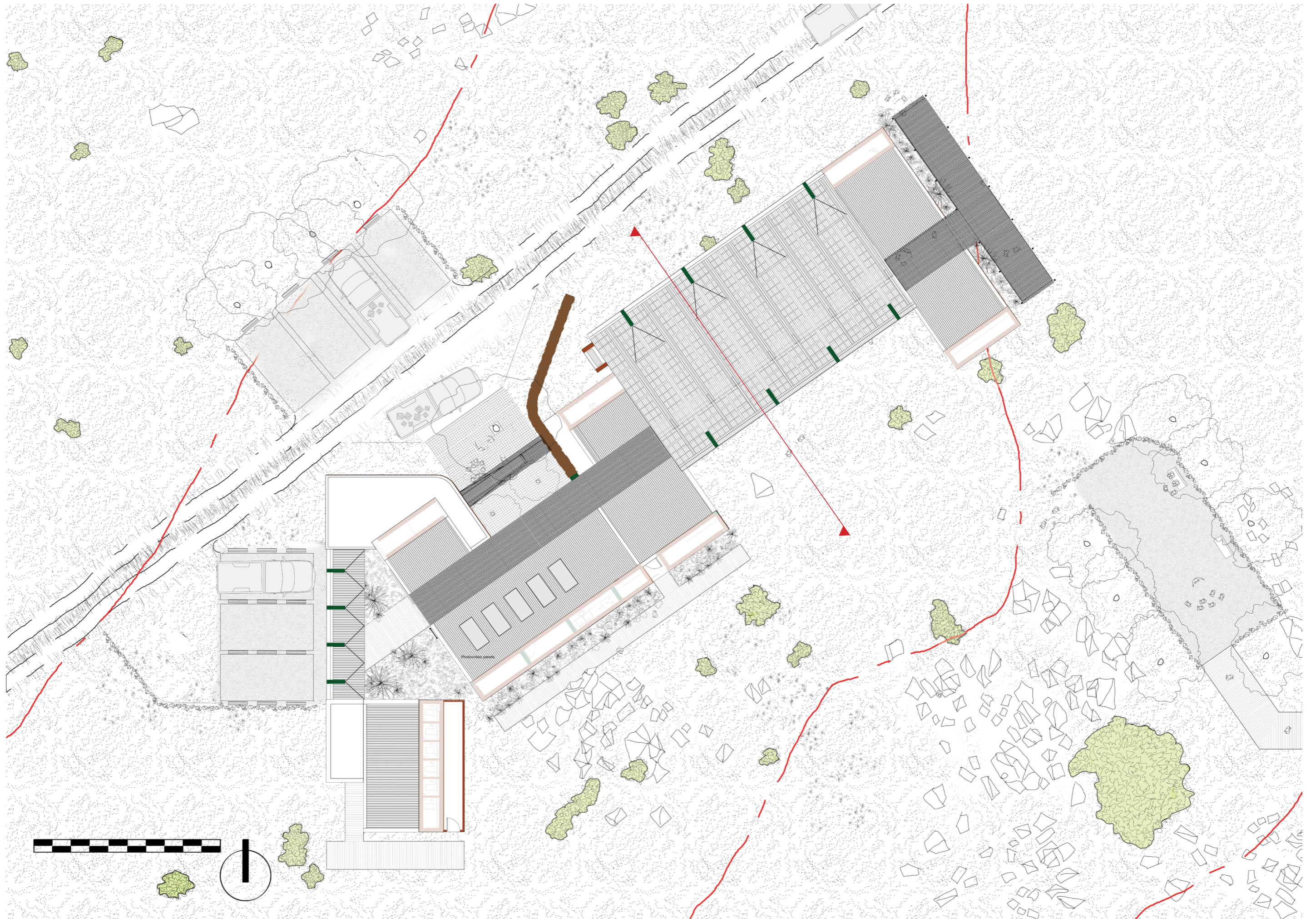
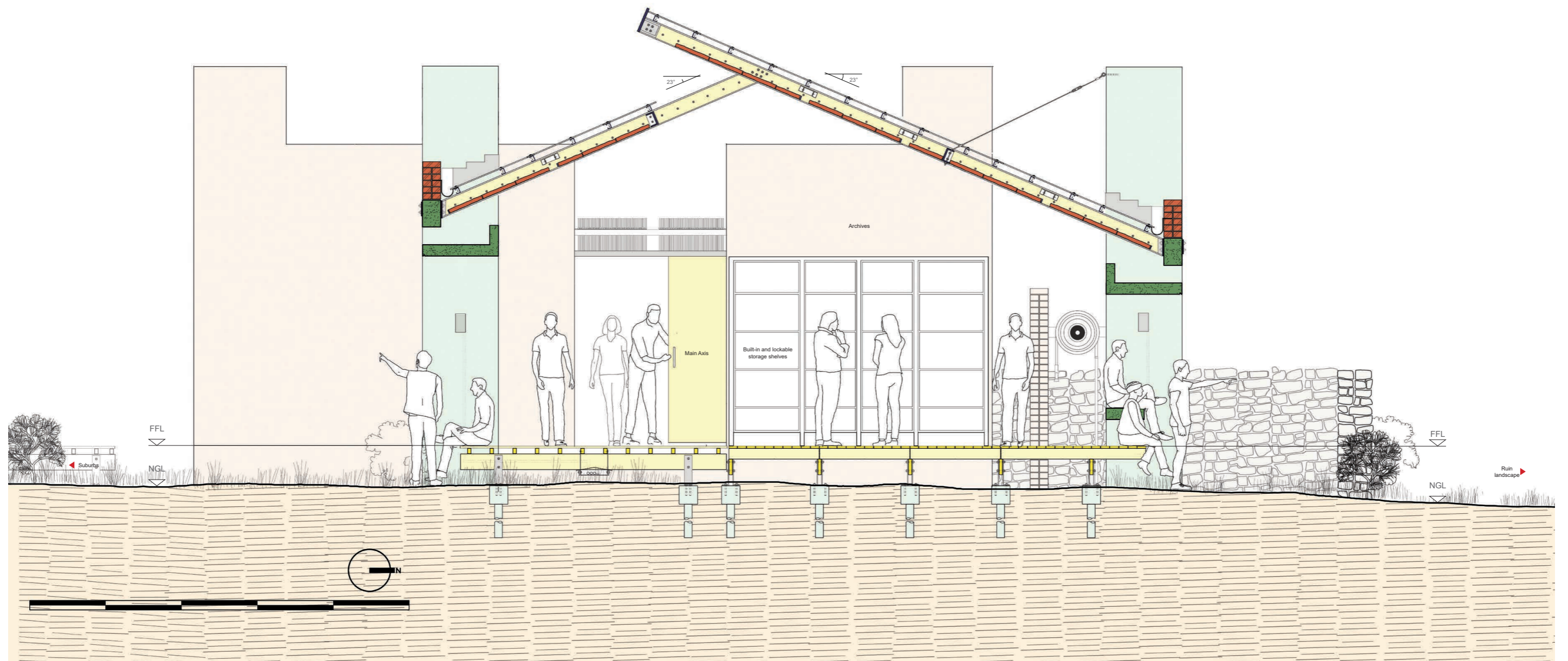

Figure 123: Section C-C as diagram through the archive showing the combined observation detail that ties the knowledge contained inside to the landscape outside (Author, 2021).









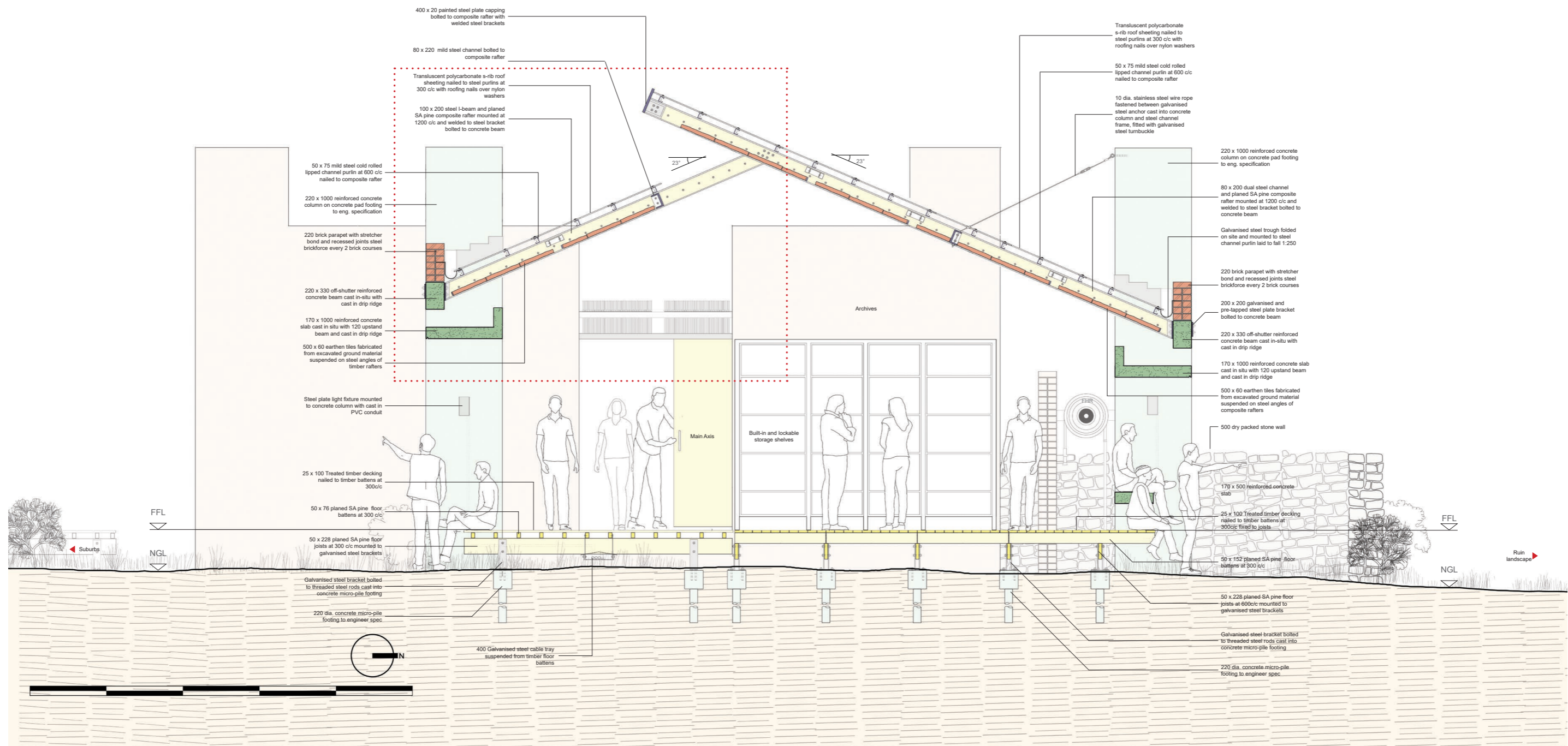

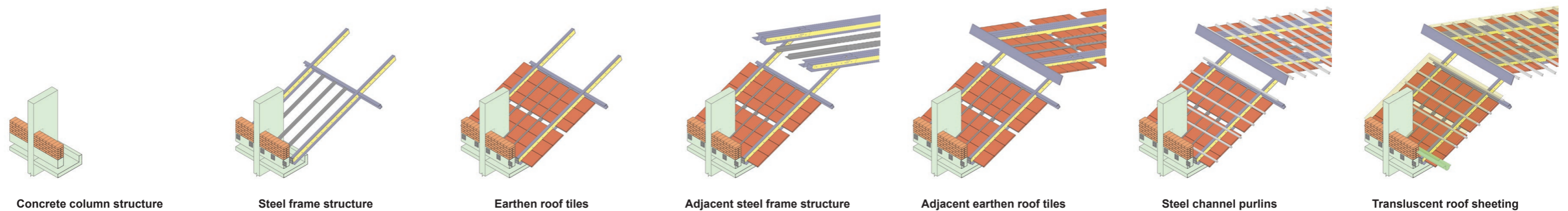
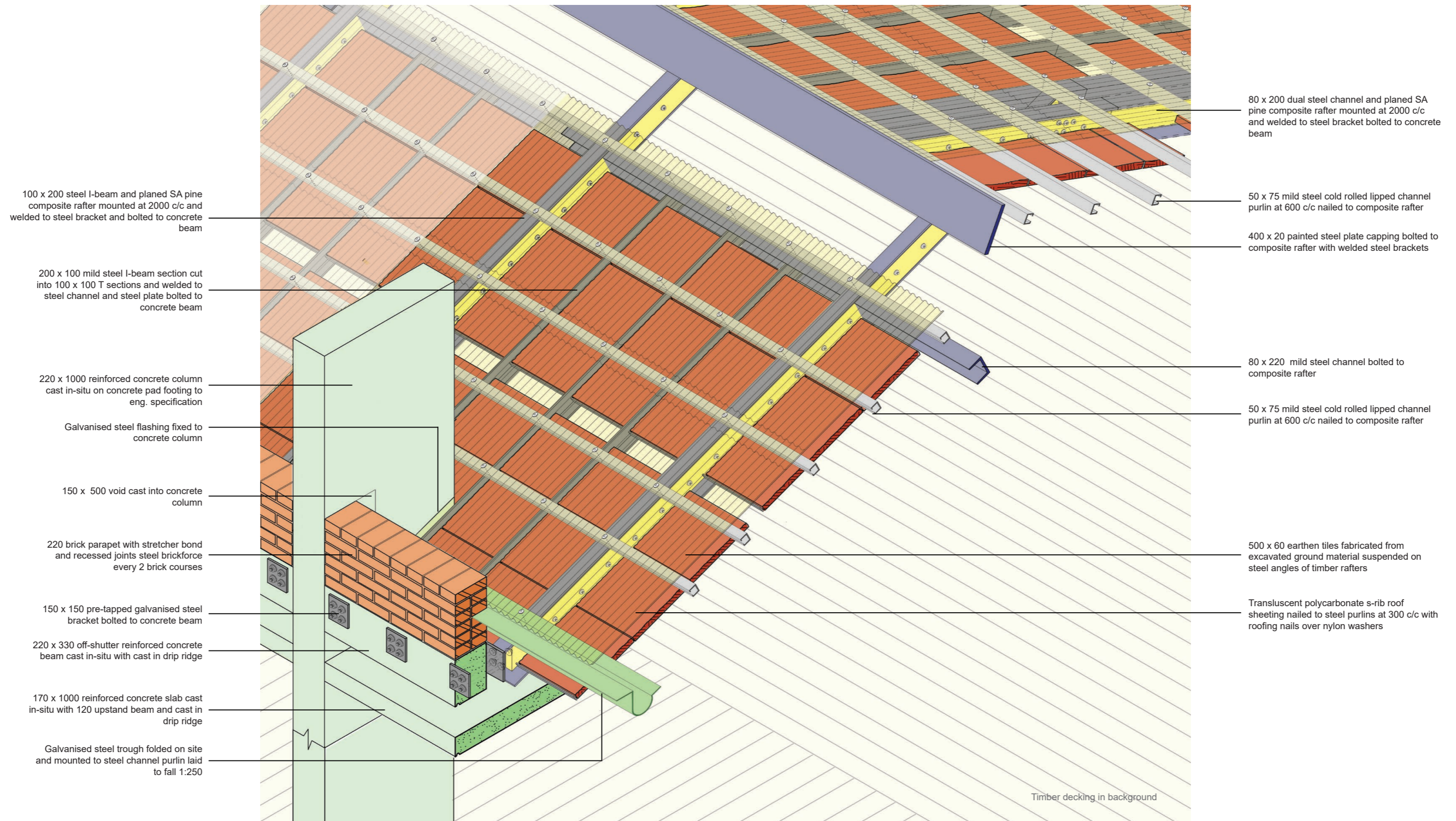

17. Sustainability analysis

This project achieves a Sustainable buildings assessment tool (SBAT) rating of 3.8. Unfortunately, the remote nature of the site makes certain criteria difficult to achieve. Various products and services are only available outside the recommended area, accessibility is limited due to the heritage sensitivity of the site and public transport systems do not link with this region. Potential improvements can be achieved through the attachment of public transport networks to the site. Furthermore, future developments that contain commercial, educational and health programmes in the area could increase the project’s score by improving general access to such services.

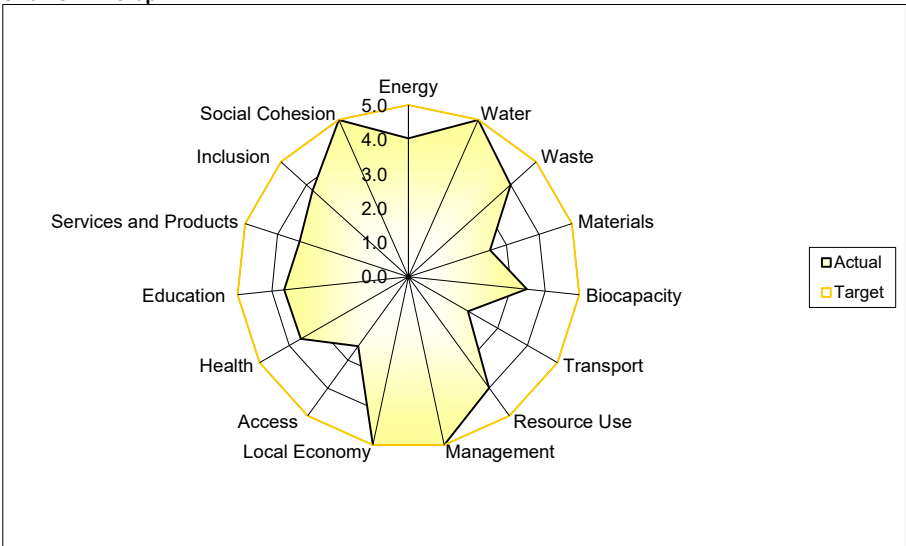

SB4 Environmental, Social and Economic Performance		Score
Environmental		3.8
Economic		3.7
Social		3.9
SBAT Rating		3.8

SB5 EF and HDI Factors		Score
EF Factor		3.3
HDI Factor		4.0

SB6 Targets		Percentage
Environmental		76
Economic		74
Social		77

Figure 130: A graph showing the ratings achieved by the project according to the Sustainable Building Assessment Tool (SBAT).

18. Conclusion

This chapter dealt with the translation of conceptual intention into architectural form. Consequently, the result of applying a living heritage framework upon an iron age ruin site is a series of buildings within a network upon the site. Both climatic responsivity and topographical adaptation were adjustments made to the initial concepts in order to ground them in a real setting. From an architectural theory point of view, a series of autonomous ideas was generated in an abstracted intangible context, and then layered upon a physical site to create a situated architecture. This network of programmes aims at framing the larger landscape between built form and programme and the site as a whole is incorporated into the heritage production process. Potential development that occurs in this region in the future could be shaped to support this programme and be informed by it. The landscape upon which this project sits will be protected by this living heritage programme. Hereafter, a reflection on the process and product of this project will be conducted in order to understand what improvements can be made for future schemes with similar themes. The influence this project will have on the author’s future as a candidate architect will also be examined.