

Revitalised Intersections, VOL. 1

By YP Mudaly

*Theoretical*

---

*Discourse*

02.

Based off the readings of precedent port cities and how they manifest along water bodies and infrastructure

PUERTO MADERO  
BUENOS AIRES



SAN FRANCISCO



ROTTERDAM



SHANGHAI



POINT HARBOUR  
DURBAN

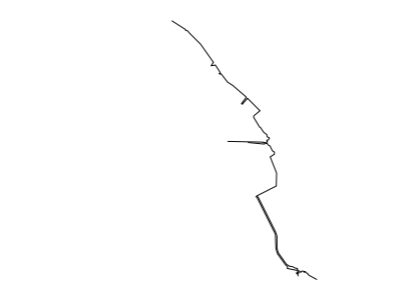
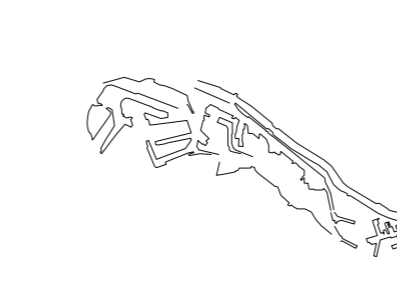
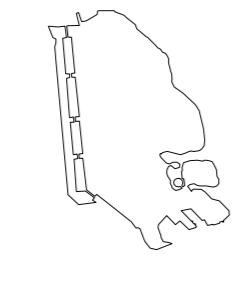

**2.2. The organisation of the water edge of harbours**

Port cities not only act as the economic centres for many water bordered cities but also act as important civic quarters for activity from the central points of the city. The importance of threshold and gathering along the water edge proves to be important and as precedent, 4 ports were analysed coherently with Point Harbour in Durban to determine significant differences.

The main junction point concentrated on within the essay is the intersection between the working harbour and the city (being the waterfront). This area rationalises circulation between sites and develops public quarters

in between operational space where edge conditions and linkages draw in synergies from surrounding areas. The rationalisation is created by defining routes and articulate promenades and precinct frameworks. According to readings from Dündar et al. (2014: 4) the waterfront is a more recognisable urban structure in a city framework which is able to expand or shrink whilst embracing specialised industrial landscapes from harbour centres. As shown in [fig. ix](#); compared to the other grand port-city layouts, Durban was identified as the least integrated upon research critique.

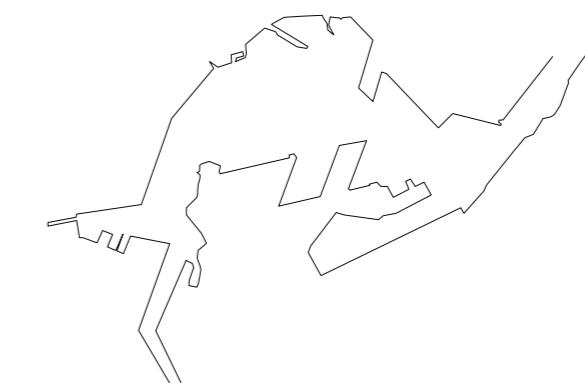

**2.1. Harbour space - Urban condition in need of transformation**

The dissertation identifies Point Waterfront as a significant and integral part of Durban's Waterfront revival and proposes a mixed use intervention which focuses on maintaining and enhancing the strong points in the Port of Durban. This design therefore narrates the spirit of the harbour with a modern interpretation of identity and spatial agency. Currently, there is no edge condition mediating the harbour mouth to the city land due to the harbour being a working port. Subsequently, the existing canal acts as a water edge by bringing in the ideal of the harbour into the city to create internal waterfronts

Due to the hinterland centralisation of programme and misalignment of urban planning, the port/harbour interface is identified as an outdated place; desolate/ abandoned or heavily industrialised in infrastructure and is now clearly severed from the cities they once used to live up. The argument for the dissertation is seen from a pragmatic and economic lens to merge historical and future aspirations of the site into a palimpsest of mixed-use neighbourhoods and connectivity.

Fig. ix. Port precedent typologies. (Mapbox 2021)

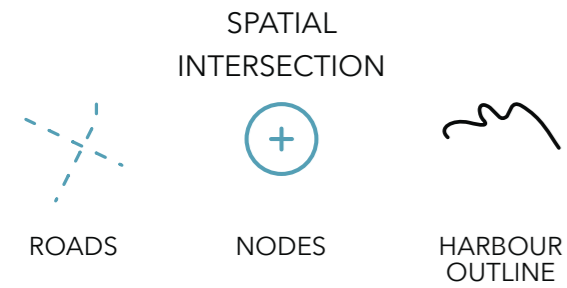

PUERTO MADERO  
BUENOS AIRES

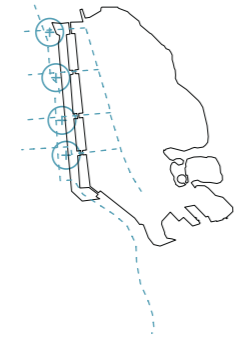

SAN FRANCISCO



ROTTERDAM

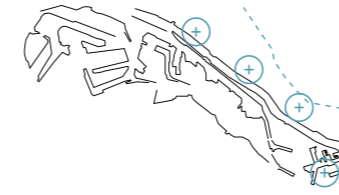

SHANGHAI

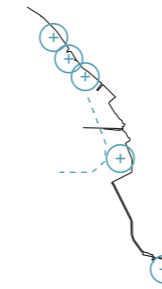

POINT HARBOUR  
DURBAN

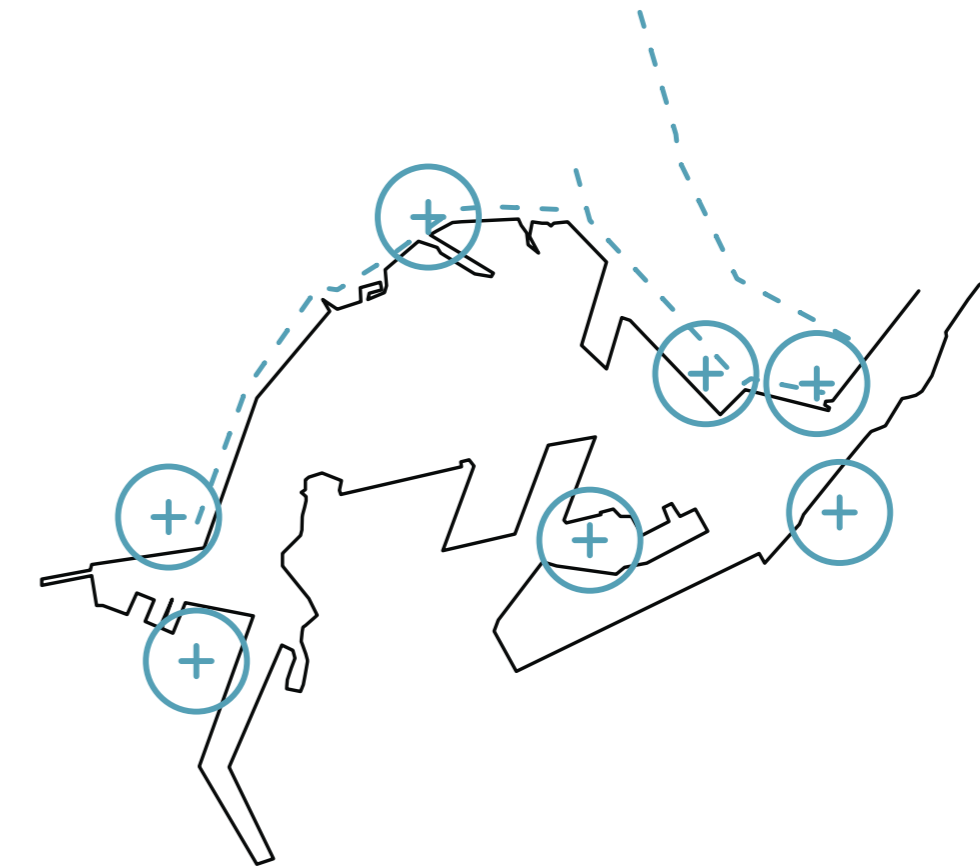

**2.3. Port City Mechanics**

Mechanics behind the workings of a port city were important spatially and for threshold and circulation. The spatial arrangement of port typologies such as wharf, pier or dock as shown in fig. 3 were explored along with factors of interface of port cities as shown in fig. 4. In the current epoch, we are in the 6th phase of development where there is a need to re-establish the port link to the city (Dündar et al. 2014).

From this analysis the curated urban framework was cultivated from the other appropriate arrangements of port-city typologies and merged the successful synergies from their context to create a normative position on how the port of Durban should be transformed. The water edge was the main informant and creating an internal harbour narrative was key.

Durban, as it currently exists, is on the fringe of a working harbour and the water edge is lost through industrialisation and privatisation of land through the boundary controlled by the TNPA (Transnet 2019).

Fig. x. Port interface diagram (Author 2021)



**EXAMPLE WHARF**  
DURBAN



**PIER**  
SAN FRANCISCO



**DOCK**  
PUERTO MADERO

**2.4. Location of port-cities according to water edge**



COMPLEX DIRECTLY  
ON THE SEA

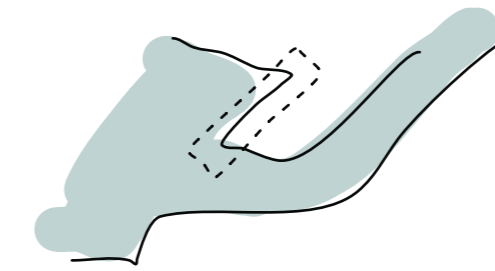

COMPLEX LOCATED INLAND  
AT A DISTANCE FROM  
NATURAL SEASHORE

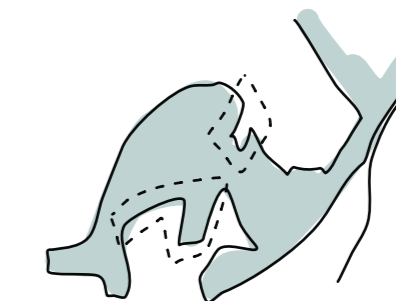

COMPLEX LOCATED ON  
THE SEA BUT DEVELOPED  
TOWARDS LAND

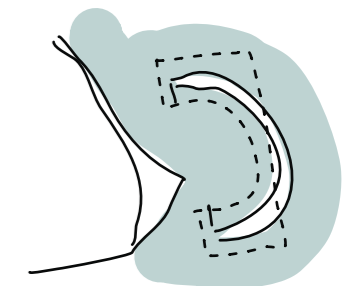

COMPLEX LOCATED  
ON PENINSULA

### 2.5. Architectural interface

Most modern ports are organised along a familiar base urban anchor, and this successful civic space encourages people to congregate along the water edge. The example of the Rotterdam river system exhibits this strategy, secreting from the harbour periphery into the city (Meurs 2012). The Port of Shanghai, on the other hand, creates a level mediation for a new ground typology which creates urban landscapes which mediates the language both employed by the city of Shanghai and the industrious landscape of the working port as seen in fig. 5. Durban on its boundary does not make use of urban port strategies as there is physical fencing off on

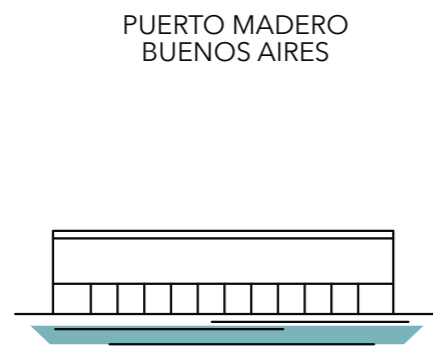

PUERTO MADERO  
BUENOS AIRES

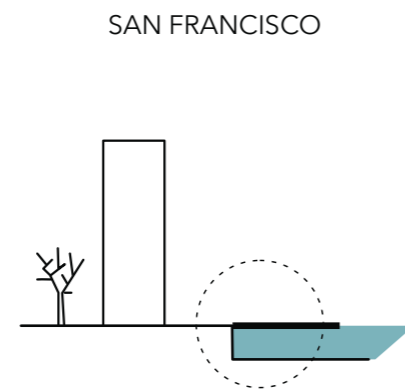

SAN FRANCISCO

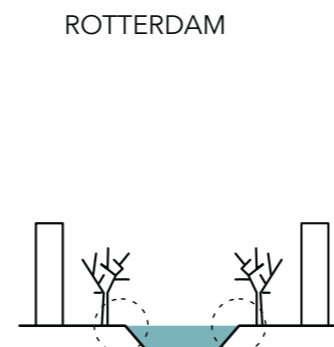

ROTTERDAM

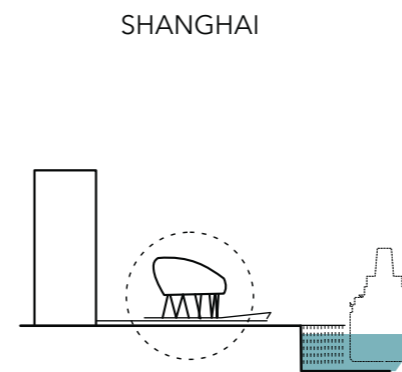

SHANGHAI

site as a result of the disassociation of contextual interfaces. This is a problem, which creates a rift between a potentially successful urban space and a derelict one.

Access holds users away from the site as the ownership and governance of the water edge is controlled by Transnet and as such

there is no relatable waterfront for Durban when compared to other privatised ports around the world. There needs to be a restructuring of the urban quadrants or an allowance for the CBD to spill into Transnet boundaries for a successful interface from built structures to water edge.

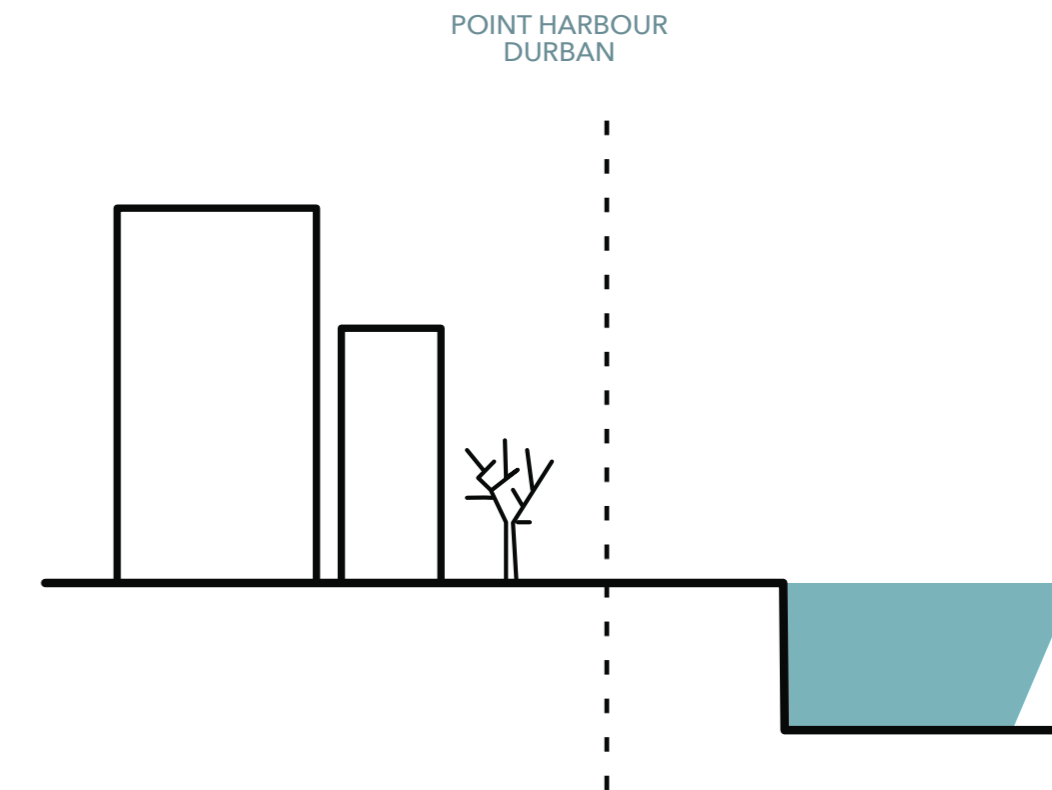

POINT HARBOUR  
DURBAN

Fig. xi. Architecture relation to water body (Author 2021)

### 2.6. Successful factors of a port city

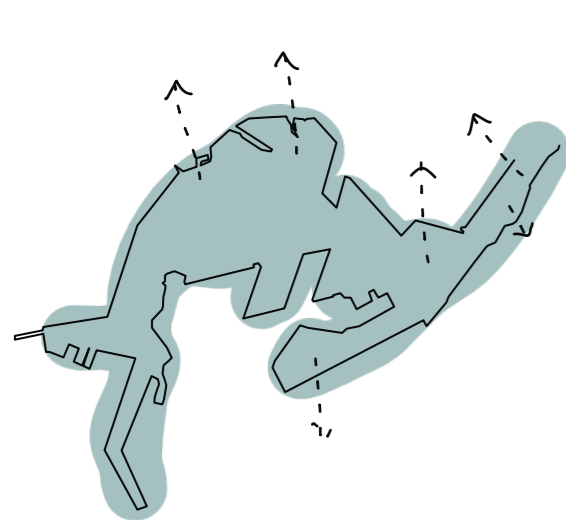

INTERFACE WITH WATER

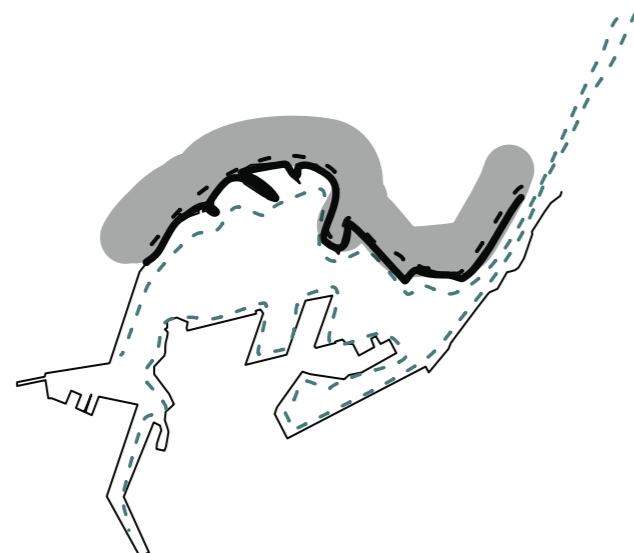

CONNECT CITY TO OUTER WORLD

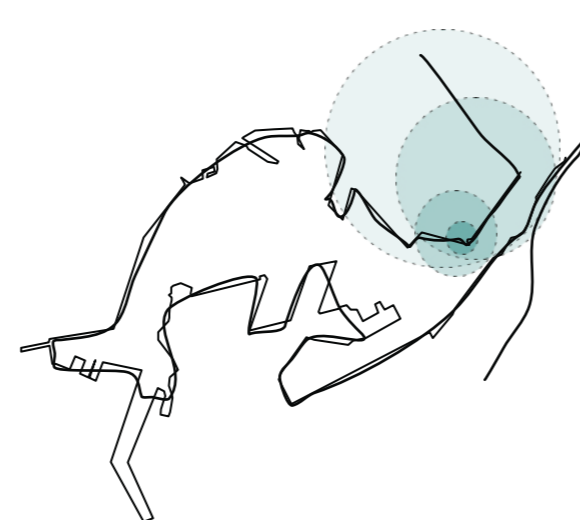

PRESENCE OF DEVELOPMENT

### 2.7. Conclusions made about Durban Harbour

The conclusions made about the Point Waterfront deduct that the assembly of poor infrastructure and lack of development that adds value to space suggest that it is not a good public urban realm. This is concluded due to the analysis of the urban quarters and proximities of anchors such as the canal to new development. There is was requirement for the dissertation to create a viable solution to poor investment from designers and urban interventions through developers.

One main issue apart from the water edge neglect was land parcel allocation for development. Land parcels are allocated to different investors and hence there is no

coherency between urban spaces in the Waterfront.

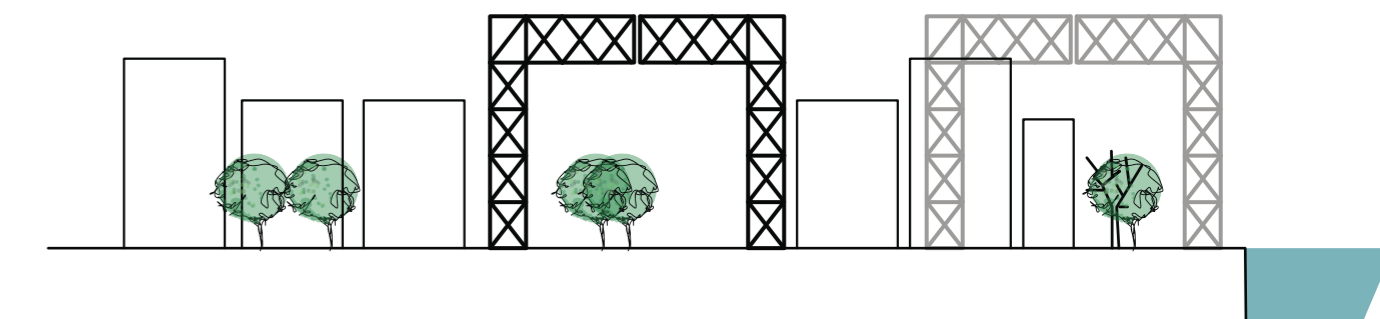

INFRASTRUCTURE AND SUPER STRUCTURE CONDITIONS



2.8. Access to controlled information

2.8.1. Interviews data

The objectives were:

i. To evaluate the efficiency of the port as well as the types of port operations occupied by each land sector and zone of the port in accordance with programme and use;

ii. To explore the necessity and the reasoning for the expansion of the port and the impact a long term phasing may have on the identity of Durban's port structure; and

iii. To collect and interpret opinions about whether the current port city typologies are comparatively better or worse to international port city typologies.

Data collected from all interviewees were consolidated into urban design and building principles which would guide the end design.

Two important quotes from Mrs Mridulekha Allopi (2021) - a representative of strategic planning for the city of eThekweni stated [sic]:

1. *"There is little connection where the port has not realised the understanding between public interface and the working port. The expansion realises this digression and hopes to solve it but apart from such there are no other linkages available. The promenade is the only link from the city towards the harbour. LAP and TNPA plans don't synergise."* (Allopi 2021)

2. *"The limitation is that the city does not do extensive research on planning and the private sector is left to clean up the area which is being developed leaving the rest to fencing off. Separating planning ideals and creating a more segregated planning ideal."* (Allopi 2021)

The following diagrams represent an amalgamation of urban and architectural strategies that, through the opinion of the interviewees, would reshape and improve the current Durban Point Waterfront and add a crucial port-city identity to the urban fabric.

Fig. xii. Interview results diagram (Author 2021)

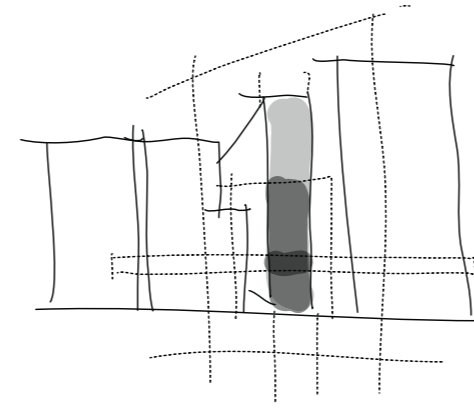

CONTROL BUILDING SCALE

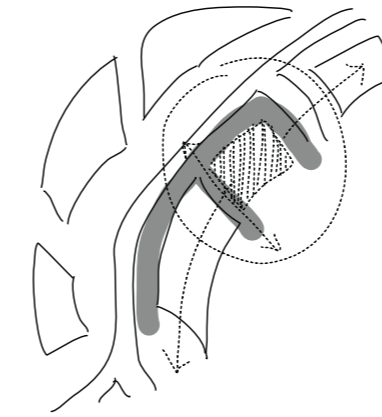

TRANSMISSION BETWEEN NEW & EXISTING

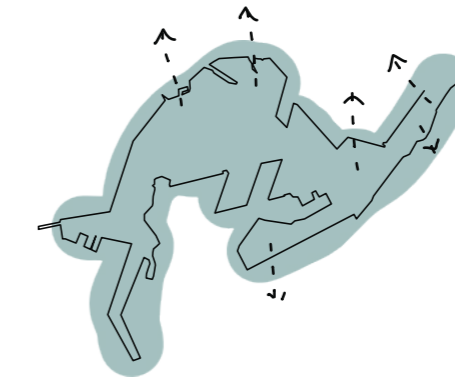

WATER EDGE CONDITION

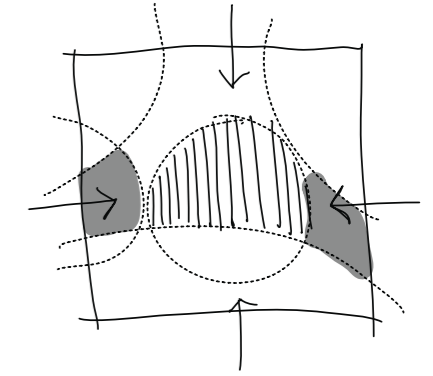

ATTRACT CIRCULATION

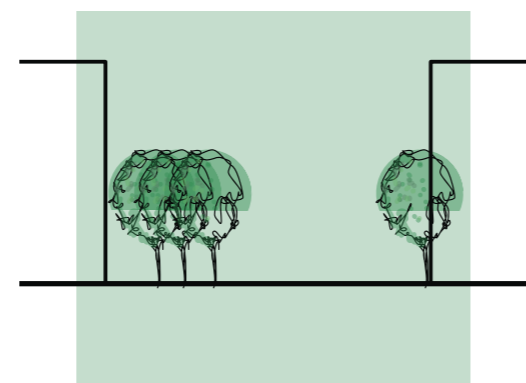

BIODIVERSITY

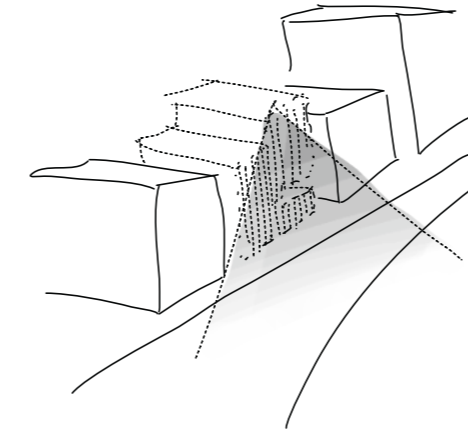

LIGHT UP AREA AT NIGHT

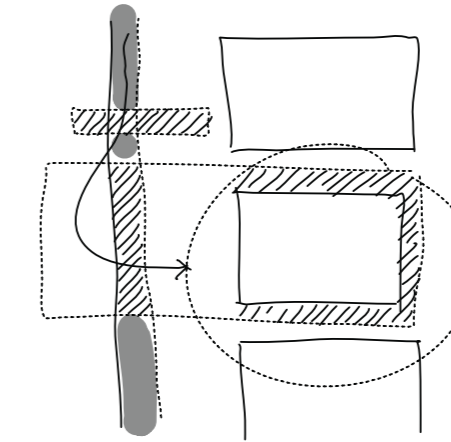

ISPS SECURE SITE

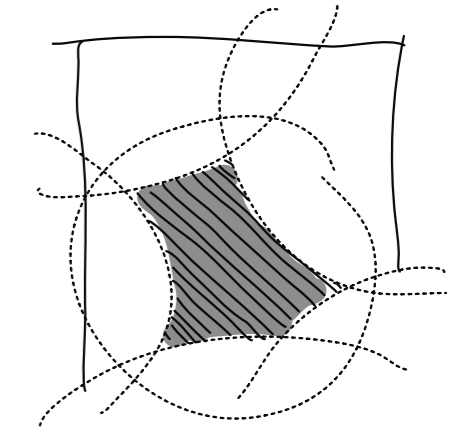

URBAN SPACE

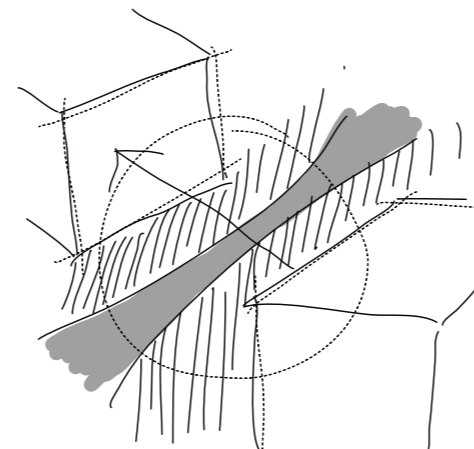

CONNECT CRUISE TERMINAL

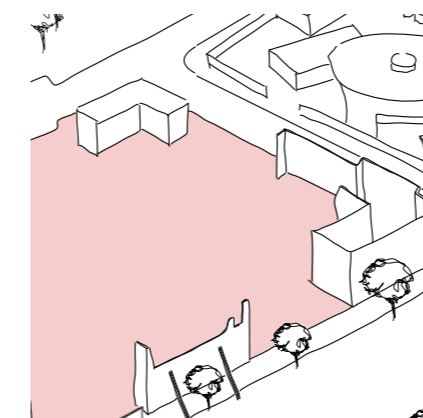

MATERIAL STRENGTH THROUGH RUINS

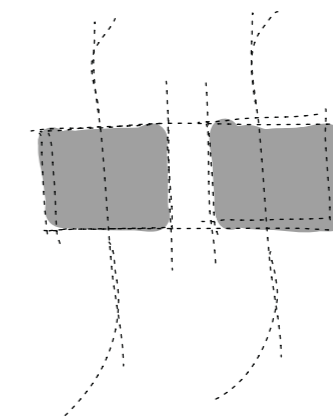

CONTINUITY OF SITE

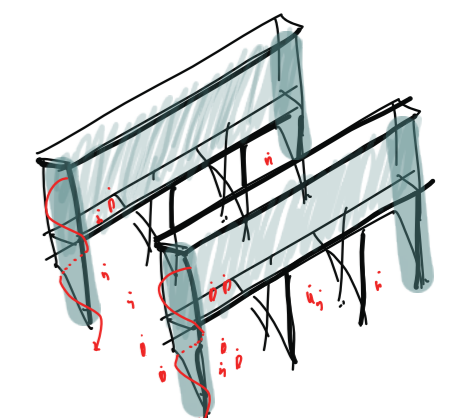

USE EXISTING INFRASTRUCTURE

*“Port Architecture also reflected the social interactions which were crucial for knitting together trading networks both within and beyond the city, while the configuration of internal building spaces reveals both implicit and explicit assumptions about the ordering of social relationships and the structuring of class-specific hierarchies more widely” (Lee 2012: 1).*