

NEONICOTINOIDS DECREASE SUCROSE RESPONSIVENESS OF HONEY BEES AT FIRST CONTACT

FABIEN J. DÉMARES^{*,1}, CHRISTIAN W.W. PIRK, SUSAN W. NICOLSON AND HANNELIE HUMAN

Affiliation: Social Insects Research Group, Department of Zoology & Entomology, University of Pretoria, Private Bag X20, Hatfield 0028, Pretoria, South Africa.

¹ Present address: *Emerging Pathogens Institute, Department of Entomology & Nematology, University of Florida, 2055 Mowry Road, Gainesville, Florida 32610, USA.*

*** Corresponding author (fabien.demares@ufl.edu)**

Supplementary Materials 1

Figure S1. Schematic outline of foragers' distribution for the experimental setup.

Table S1. PER rate values of the different exposures and neonicotinoids.

Table S2. Statistical analyses of survival and consumption parameters.

Supplementary Materials 2 (attached Excel File)

Tables S3. GEE/GLM Fit and Interaction + Estimated Marginal Means of main factors

Tables S4. EM Means of Interaction Feeding * Sucrose Concentrations.

Tables S5. EM Means of Interaction Test * Sucrose Concentrations.

Tables S6. EM Means of Interaction Feeding * Test.

Figure S1.

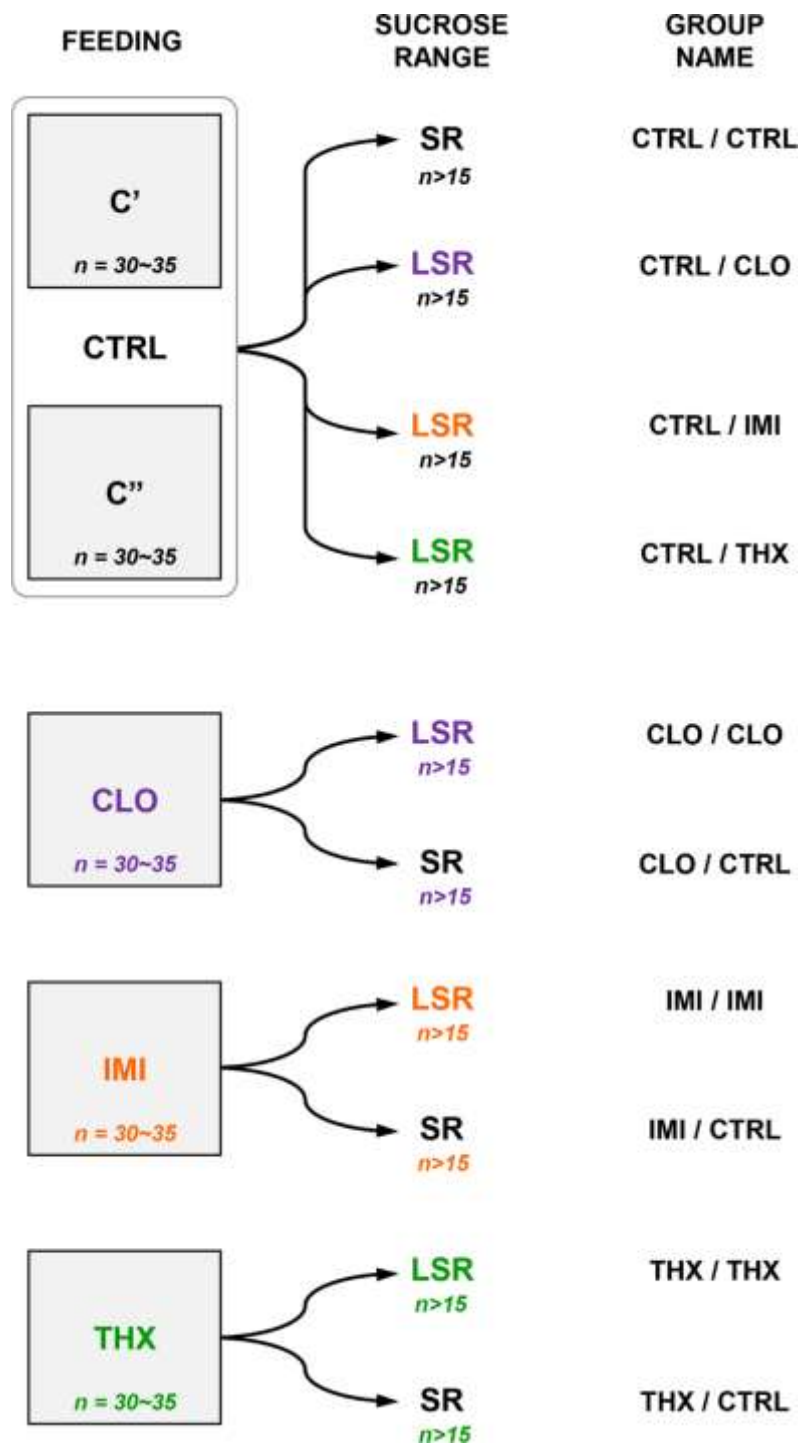

Figure S1. Schematic outline of foragers' distribution during feeding and sucrose test. For each colony, foragers were distributed between five cages and received either pure sucrose or spiked sucrose as feeding solution for 24 hours. The next day, foragers were divided into subgroups: control (CTRL) bees were divided into four and would be tested either for pure sucrose range (SR) or for spiked sucrose range (sSR) containing one of the three neonicotinoids (CLO, clothianidin; IMI, imidacloprid; THX thiamethoxam). Bees fed on spiked sucrose were divided into two and would be tested either for SR or for sSR with the neonicotinoid compound they have been exposed over the last 24 hours. Each group corresponds to a different type of neonicotinoid exposure: "CTRL/CTRL" unexposed control foragers; "X/CTRL" only exposed to pesticide in the food; "CTRL/X" only exposed to pesticide during sucrose test; "X/X" exposed in both food and sucrose test (X represents one of three aforementioned neonicotinoids).

Table S1. PER rate values of the different exposures and neonicotinoids.

Food	Test	n	Sucr. 0.03%	Sucr. 0.10%	Sucr. 0.30%	Sucr. 1.0%	Sucr. 3.0%	Sucr. 10%	Sucr. 30%
CTRL	CTRL	52	3.85%	9.62%	25.00%	44.23%	69.23%	82.69%	96.15%
CTRL	CLO	52	3.85%	1.92%	15.38%	25.00%	40.38%	61.54%	76.92%
CTRL	IMI	52	1.92%	3.85%	11.54%	15.38%	25.00%	53.85%	65.38%
CTRL	THX	49	8.16%	12.24%	6.12%	4.08%	20.41%	44.90%	55.10%
CLO	CTRL	52	3.85%	13.46%	23.08%	28.85%	42.31%	50.00%	71.15%
CLO	CLO	52	7.69%	11.54%	13.46%	17.31%	34.62%	44.23%	65.38%
IMI	CTRL	47	0.00%	12.77%	12.77%	31.91%	40.43%	55.32%	59.57%
IMI	IMI	50	4.00%	10.00%	12.00%	24.00%	22.00%	44.00%	52.00%
THX	CTRL	48	2.08%	10.42%	20.83%	31.25%	39.58%	52.08%	60.42%
THX	THX	46	4.35%	4.35%	10.87%	19.57%	39.13%	43.48%	65.22%

Table S2. Statistical analyses of survival and consumption parameters.**A) Test of Normality (Shapiro's Test)**

	Shapiro-Wilk Statistic	df	Sig.
Survival after 24h (%)	0.946	20	0.314
Consumption (µl/bee)	Water	17	0.283
	Sucrose	20	0.290
Dose ingested (ng/bee)	0.953	15	0.578
Percentage of LD₅₀	0.962	15	0.728

B) Test of Homoscedasticity (Levene's Test)

	Levene Statistic	df1	df2	Sig.
Survival after 24h (%)	2.432	3	16	0.103
Consumption (µl/bee)	Water	3	13	0.250
	Sucrose	3	16	0.183
Dose ingested (ng/bee)	2.069	2	12	0.169
Percentage of LD₅₀	3.659	2	12	0.057

Note for Tables S2 A & B:

In total, 20 cages were compared for survival and consumption, 5 for each treatment. Differences in df for water are due to 3 cages excluded from analysis because of drowned bee in water tubes, biasing the water consumption values (1 cage excluded in CTRL, 1 in CLO and 1 in IMI). For dose ingested and LD₅₀ analyses, we only looked at neonicotinoid-treated groups, CTRL was not included, resulting in 15 cages compared.

C) Analyses of variances of the different parameters (One-way ANOVA)

		Sum of Squares	df	Mean Square	F	Sig.	
Survival after 24h (%)	Between Groups	0.00135	3	0.00045	0.271	0.846	
	Within Groups	0.02670	16	0.00167			
	Total	0.02805	19				
Consumption (µl/bee)	Water	Between Groups	141.81961	3	47.27320	0.845	0.493
		Within Groups	727.28258	13	55.94481		
		Total	869.10219	16			
	Sucrose	Between Groups	298.50074	3	99.50025	2.582	0.090
		Within Groups	616.47456	16	38.52966		
		Total	914.97530	19			
Dose ingested (ng/bee)	Between Groups	0.00226	2	0.00113	7.929	0.006	
	Within Groups	0.00171	12	0.00014			
	Total	0.00397	14				
Percentage of LD₅₀	Between Groups	0.00002	2	0.00001	1.250	0.321	
	Within Groups	0.00012	12	0.00001			
	Total	0.00014	14				

D) Post-hoc tests on “Dose ingested” (Tukey HSD pairwise comparisons)

		Mean Difference	Std. Error	Sig.	95% Confidence Interval	
					Lower Bound	Upper Bound
CLO	IMI	-0.0084	0.00755	0.525	-0.0285	0.0117
	THX	-0.0292	0.00755	0.006	-0.0493	-0.0091
IMI	CLO	0.0084	0.00755	0.525	-0.0117	0.0285
	THX	-0.0208	0.00755	0.043	-0.0409	-0.0007
THX	CLO	-0.0292	0.00755	0.006	0.0091	0.0493
	IMI	-0.0208	0.00755	0.043	0.0007	0.0409