

# The **NZASM** Tourist Precinct

Tourism Interventions as Catalyst to re-Establish the Cultural Significance of  
Historic Railway Housing in Pretoria CBD

LAURIKA BRÜMMER



*Vir Wichard*

Submitted in partial fulfilment of the requirements  
for the degree Master of Interior Architecture  
(Professional) to the faculty of Engineering,  
Built Environment and Information Technology.

**By Laurika Brümmer**

Department of Architecture

University of Pretoria

2017

**Study Leader:** Catherine Karusseit

**Course coordinator:** Catherine Karusseit

In accordance with Regulation 4(e) of the General Regulations (G.57) for dissertations and theses, I declare that this dissertation, which I hereby submit for the degree of Masters of Interior Architecture (Professional) at the University of Pretoria, is my own work and has not previously been submitted by me for a degree at this or any other tertiary institution.

I further state that no part of my dissertation has already been, or is currently being, submitted for any such degree, diploma or other qualification.

I further declare that this thesis is substantially my own work. Where reference is made to the works of others, the extent to which that work has been used is indicated and fully acknowledged in the text and list of references.

Laurika Brümmer

## PROJECT SUMMARY

<b>Dissertation title:</b>	The NZASM Tourist Precinct: Tourism Interventions as Catalyst to re-Establish the Cultural Significance of Historic Railway Housing in Pretoria CBD
<b>Project description:</b>	A catalyst is required to acknowledge and celebrate the cultural significance of the historical residential structures located to the east of the Pretoria Train Station, in the NZASM heritage area.
<b>Programme:</b>	Tourist Precinct
<b>Site description:</b>	A residential area in Pretoria CBD where historic railway houses are in existence
<b>Site location:</b>	East of the Pretoria Train Station, in the South-East Quadrant of Pretoria CBD, South Africa
<b>Address:</b>	Tulleken Street and Rider Haggard Street
<b>GPS coordinates:</b>	25°45'29.2"S 28°11'31.5"E
<b>Research field:</b>	Heritage and Cultural Landscapes (HCL)
<b>Keywords:</b>	Interior architecture, NZASM, heritage alteration, adaptive reuse, regeneration strategy, resilience, heritage and cultural tourism
<b>Chosen client and users:</b>	The local community and tourists
<b>Interior architectural theoretical question:</b>	How can the introduction of tourism act as a catalyst to acknowledge and celebrate the cultural significance of the NZASM houses and the area?
<b>Interior architectural approach:</b>	Intervention as method of heritage alteration

## ABSTRACT

The number of single-family residences in the Nederlandsche Zuid-Afrikaansche Spoorweg-Maatschappij (NZASM) heritage area, to the east of the Pretoria Train Station, has decreased over recent years. Due to the pressures of the Tshwane Compaction and Densification Strategy (2005) and the addition of high rise apartment blocks positioned between the houses, the area's density is certain to increase further and the future of these heritage structures are in jeopardy. A fragmented urban environment has resulted, which is further emphasised by the discrepancy in scale and density of the built structures.

The few remaining houses have been altered in varying degrees to suit the needs of their occupants, with no regard to their heritage value in most cases. An approach to maintain the cultural and historical value of the area would be to introduce a new function which would attract diverse visitors in a bid to regenerate the area. As a catalyst to generate interest, tourist interventions are proposed in and around selected houses, with the intention of stitching the fragmented urban fabric from the interior outwards. The vision for the site is to create the NZASM Tourist Precinct, with different amenities and accommodation options for tourists.

### KEYWORDS:

Interior architecture, NZASM, heritage alteration, adaptive reuse, regeneration strategy, resilience, heritage and cultural tourism.

## OPSOMMING

Die getal huise in die Nederlandsche Zuid-Afrikaansche Spoorweg-Maatschappij (NZASM) erfenis-area, oos van die Pretoria treinstasie het verminder oor die afgelope paar jaar. As gevolg van die druk van die Tshwane Compaction and Densification Strategy (2005) en hoë woonstel-blokke wat onlangs tussen die huise gebou is, bestaan daar 'n sekerheid dat die area se digtheid verder gaan verhoog, wat die bestaan van die erfenishuise bedreig. Dit het 'n gefragmenteerde stedelike omgewing tot gevolg gehad, wat verder beklemtoon word deur die skaalverskil en digtheid van die bestaande strukture.

### KERNWOORDE:

Binne-argitektuur, NZASM, erfenisaanpassings, aanpasbare hergebruik, herlewingsstrategie, veerkragtigheid, erfenis en kulturele toerisme.

Die paar oorblywende huise het al verskeie veranderinge ondergaan om aan die behoeftes van hulle inwoners te voldoen, met geen inagneming van hul erfeniswaarde nie. 'n Voorstel om die kulturele en historiese waarde van die area te behou en versterk, en die area te vernuwe, sluit in om 'n nuwe funksie voor te stel wat 'n verskeidenheid besoekers sal trek. As 'n katalisator om belangstelling te wek, word toerisme-intervensies in en om geselekteerde huise voorgestel, met die doel om die gefragmenteerde stedelike materiaal van binne na buite te versterk. Die visie vir die area is om die NSASM toeriste-omgewing te skep, met verskillende geriewe en akkommodasie-opsies vir toeriste.



## TABLE OF CONTENTS

Declaration . . . . .	2.2.5 Route from Gautrain station to site .42	4.9 Programme 1: Emscher Village . . . . .72	5.3.11 The NZASM exhibition . . . . . 127
Project summary . . . . .	2.2.6 Programmatic layout . . . . . .44	4.10 Programme 2: Vilakazi Street Precinct . 73	5.3.12 The tourist information office . . . 131
Abstract . . . . .	2.2.7 Model tourist & community member . 46	4.11 Programme 3: Tardets-Sorholus . . . .74	5.3.13 Ceiling plan and lighting layout . 135
Opsomming . . . . .	2.2.8 Conclusion . . . . . . . . . . .47	4.12 Conclusion . . . . . . . . . . .75	5.3.14 Restaurant kitchen and bar . . . . 140
<b>CHAPTER 1: INTRODUCTION</b>	<b>CHAPTER 3: THEORY</b>	<b>CHAPTER 5: DESIGN AND TECHNICAL DEVELOPMENT</b>	<b>CHAPTER 6: CONCLUSION</b>
1.1 Introduction . . . . . 1	3.1 Introduction . . . . . . . . . . .51	5.1 Introduction . . . . . . . . . . .79	6.1 Recapitulation . . . . . . . . . . 151
1.2 Background . . . . . . . . . . . 1	<b>PART 1: HERITAGE</b>	<b>PART 1: DESIGN INFORMANTS</b>	6.1.1 Chapter Summaries . . . . . . . 151
1.3 Problem statement . . . . . . . . 2	3.1.1 Alteration . . . . . . . . . . .52	5.1.1 Context . . . . . . . . . . . .80	6.2 Conclusions . . . . . . . . . . . 151
1.4 Research questions . . . . . . . . 2	<b>PART 2: RESILIENCE</b>	5.1.2 Programme . . . . . . . . . . .83	6.3 Contributions . . . . . . . . . . 152
1.5 Aim/Objective . . . . . . . . . . . 2	3.2.1 Urban resilience and regeneration . .54	5.1.3 Theory. . . . . . . . . . . . .84	6.4 Recommendations . . . . . . . . 152
1.6 Significance of study . . . . . . . . 2	3.2.2 Community sustainability . . . . . .55	5.1.4 Case studies and precedents . . . .85	
1.7 Research method . . . . . . . . . . 3	<b>PART 3: HERITAGE AND CULTURAL TOURISM</b>	<b>PART 2: DESIGN DEVELOPMENT</b>	
1.8 Delineation and limitations . . . . . 4	3.3.1 Developing a place identity. . . . .56	5.2.1 Conceptual approach . . . . . .86	
1.9 Assumptions . . . . . . . . . . . 4	3.3.2 Sustainable tourism . . . . . . .56	5.2.2 Envisioned atmosphere . . . . . .87	
1.10 Overview of study . . . . . . . . . 4	3.3.3 Heritage and culture . . . . . . .57	5.2.3 Urban vision. . . . . . . . . . .88	
1.11 Conclusion . . . . . . . . . . . 4	3.3.4 The target market . . . . . . . .57	5.2.5 Materiality . . . . . . . . . . .95	
<b>CHAPTER 2: CONTEXT</b>	3.4. Regeneration strategy . . . . . .58	5.2.6 Pattern development. . . . . . .98	
<b>PART 1: CONTEXT ANALYSIS</b>	3.5 Conclusion . . . . . . . . . . .59	5.2.7 Development of plans . . . . . 100	
2.1.1 Context introduction . . . . . . . 9	<b>CHAPTER 4 : CASE STUDIES AND PRECEDENTS</b>	5.2.8 Conceptual models . . . . . . 102	
2.1.2 Historical development. . . . . .11	4.1 Introduction . . . . . . . . . . .63	<b>PART 3: TECHNICAL DEVELOPMENT</b>	
2.1.3 Similar housing typology. . . . . .12	4.2 The effects of tourism . . . . . . .63	5.3.1 Introduction. . . . . . . . . . .104	
2.1.4 Historical timeline . . . . . . . .14	4.3 Case study 1: The Bo-Kaap . . . . .64	5.3.2 Research questions . . . . . . 104	
2.1.5 General site analysis. . . . . . .16	4.4 Case study 2: Hoi An Ancient Town . .66	5.3.3 Outcome . . . . . . . . . . . 104	
2.1.6 15 and 17 Tulleken street . . . . .26	4.5 Measuring the effects of tourism. . . .68	5.3.4 Areas of resolution . . . . . . .104	
2.1.7 19 Tulleken street . . . . . . . .30	4.6 Heritage precedent 1: Hedmark . . . .69	5.3.5 Approach to technical resolution . 105	
2.1.8 21 and 23 Tulleken street . . . . .34	4.7 Heritage precedent 2: Neues Museum.70	5.3.6 Heritage alteration audit . . . . .105	
2.1.9 Statement of significance . . . . .36	4.8 Heritage precedent 3: Gehry House . .71	5.3.7 Final design. . . . . . . . . . .106	
<b>PART 2: PROGRAMME</b>		5.3.8 Entrance strategy . . . . . . . 116	
2.2.1 Tourism as catalyst . . . . . . .38		5.3.9 Youth hostel. . . . . . . . . . .116	
2.2.2 Tshwane Tourist Information Office.39		5.3.10 Tourist centre reception . . . . .124	
2.2.3 Site amenities. . . . . . . . . . .40			
2.2.4 Tourist attractions. . . . . . . . .40			
			<b>LIST OF REFERENCES . . . . . 154</b>
			<b>APPENDIX</b>
			A Informal community discussion . . . . . 156
			B Documentation and analysis:
			10 Rider Haggard Street . . . . . . 157
			25 Rider Haggard Street . . . . . . 158
			C Thermal calculations. . . . . . . . . 159
			D Final model . . . . . . . . . . . 160
			E Final examination . . . . . . . . . 161
			F Final posters . . . . . . . . . . . 162

## LIST OF FIGURES

<b>Figure 1.1 Chapter cover page: Conceptual collage of the site</b> (Author 2017). . . . .	1	<b>Figure 2.1.32: Map of movement and activity</b> (Author 2017) . . . . .	24	<b>Figure 2.1.51: Wooden fireplace in the dining room</b> (Author 2017) . . . . .	31
<b>Figure 2.1 Chapter Cover Page: Drawing of the site, viewed from a North-Western direction</b> (Author 2017) . . . . .	9	<b>Figure 2.1.33: Map of boundaries</b> (Author 2017) .25		<b>Figure 2.1.52: Pendant in the entrance foyer</b> (Author 2017) . . . . .	31
<b>Figure 2.1.1: The location of the site in Pretoria</b> (Author 2017) . . . . .	9	<b>Figure 2.1.34: Tulleken Street elevation</b> (Author 2017) . . . . .	26	<b>Figure 2.1.53: A brass lightswitch</b> ( Author 2017) 31	
<b>Figure 2.1.2: The location of the site in the South Eastern Quadrant of Pretoria CBD</b> (Author 2017) 9		<b>Figure 2.1.35: 15 and 17 Tulleken Street indicated on the site keyplan</b> (Author 2017) . . . . .	26	<b>Figure 2.1.54: The street-facing veranda</b> (Author 2017) . . . . .	31
<b>Figure 2.1.3: The site consisting of Tulleken, Rider Haggard &amp; Clara streets</b> (Author 2017). . . . .	9	<b>Figure 2.1.36: 15 and 17 Tulleken Street in 1990</b> (Le Roux 1990:160) . . . . .	26	<b>Figure 2.1.55: View of the passage from the entrance foyer</b> (Author 2017). . . . .	31
<b>Figure 2.1.4: Plan and elevation of Type B semi-detached cottage, NZASM drawing dated 12 June 1894</b> (de Jong 1990:56) . . . . .	11	<b>Figure 2.1.37: 15 and 17 Tulleken Street in 2009</b> (Google Earth 2017) . . . . .	26	<b>Figure 2.1.56: Plan and elevation of Type C semi-detached cottage, NZASM drawing</b> (de Jong 1988) . . . . .	31
<b>Figure 2.1.5: Plan and elevation of Type C semi-detached cottage, NZASM drawing</b> (de Jong 1988) . . . . .	11	<b>Figure 2.1.38: 15 and 17 Tulleken Street in 2017</b> (Author 2017) . . . . .	26	<b>Figure 2.1.57: Documentation and analysis of 19 Tulleken Street</b> (Author 2017) . . . . .	32
<b>Figure 2.1.6: Elevation of Type C semi-detached cottage, NZASM-hof Salvokop Village</b> (Dutch Footsteps 2016) . . . . .	11	<b>Figure 2.1.39: An arched doorway between the passage to the dining room</b> (Author 2017) . . . . .	27	<b>Figure 2.1.58: Mapping of precious heritage fabric and previously altered fabric</b> (Author 2017). . . . .	33
<b>Figure 2.1.7: Elevation of Type C semi-detached cottage, NZASM Volksrust Railways Precinct</b> (Dutch Footsteps 2016) . . . . .	11	<b>Figure 2.1.40: A pressed metal ceiling in the main bedroom</b> (Author 2017) . . . . .	27	<b>Figure 2.1.59: Tulleken Street elevation</b> (Author 2017) . . . . .	34
<b>Figure 2.1.8: The street facing façade of NZASM House</b> (ABLEWiki 2010) . . . . .	11	<b>Figure 2.1.41: The masonry fireplace in the dining room</b> (Author 2017). . . . .	27	<b>Figure 2.1.60: 21 and 23 Tulleken Street indicated on the site keyplan</b> (Author 2017) . . . . .	34
<b>Figure 2.1.9: Southern elevation</b> (ABLEWiki 2010) 11		<b>Figure 2.1.42: The transition between the vinyl tiles in the kitchen to the vinyl tiles on the enclosed back porch</b> (Author 2017). . . . .	27	<b>Figure 2.1.61: 21 Tulleken Street in 1990</b> (le Roux 1990:160) . . . . .	34
<b>Figure 2.1.10: Postcard in colour printed by Braune &amp; Levy, Johannesburg, no. 2122 depicting the Pretoria Train Station</b> (UP Repository 2017) 11		<b>Figure 2.1.43: Plan and elevation of Type B semi-detached cottage, NZASM drawing dated 12 June 1894</b> (de Jong 1990:56) . . . . .	27	<b>Figure 2.1.62: 21 Tulleken Street in 2009</b> (Google Earth 2017) . . . . .	34
<b>Figure 2.1.11: Mapping of houses similar to the residential typology on site</b> (all images Google Earth 2017) . . . . .	12	<b>Figure 2.1.44: Documentation and analysis of 15 and 17 Tulleken Street</b> (Author 2017). . . . .	28	<b>Figure 2.1.63: 21 Tulleken Street in 2017</b> (Author 2017) . . . . .	34
<b>Figure 2.1.12: A view of Pretoria from South of the railway station</b> (in the foreground), dating from late 1890's (Centenary Album 1953:87) . . . . .	14	<b>Figure 2.1.45: Mapping of precious heritage fabric and previously altered fabric</b> (Author 2017). . . . .	29	<b>Figure 2.1.64: Documentation and analysis of 21 and 23 Tulleken Street</b> (Author 2017). . . . .	35
<b>Figure 2.1.13: Compass sketch plan of Pretoria Transvaal in 1879</b> (Van der Waal Collection) . . . . .	14	<b>Figure 2.1.46: Tulleken Street elevation</b> (Author 2017) . . . . .	30	<b>Figure 2.1.65: Mapping of precious heritage fabric and previously altered fabric</b> (Author 2017) . . . . .	35
<b>Figure 2.1.14: The layout of Pretoria's plots in 1902</b> (Van der Waal Collection). . . . .	14	<b>Figure 2.1.47: 19 Tulleken Street indicated on the site keyplan</b> (Author 2017) . . . . .	30	<b>Figure 2.2.1: Exterior Western elevation of Old Nederlandsche Bank</b> (AbleWiki 2010) . . . . .	39
<b>Figure 2.1.15: The layout of Pretoria's plots, date unknown</b> (Van der Waal Collection, map provided by J. Swart, 2016) . . . . .	14	<b>Figure 2.1.48: 19 Tulleken Street in 1990</b> (Le Roux 1990:160) . . . . .	30	<b>Figure 2.2.2: Exterior directional signage</b> (AbleWiki 2010) . . . . .	39
<b>Figure 2.1.16: The layout of Pretoria's plots, 1979</b> (Van der Waal Collection 2016). . . . .	15	<b>Figure 2.1.49: 19 Tulleken Street in 2009</b> (Google Earth 2017) . . . . .	30	<b>Figure 2.2.3: Photos and analysis of the existing tourist information office</b> (Author 2017) . . . . .	39
<b>Figure 2.1.17: An aerial photograph of Paul Kruger Street, showing the city hall, the Transvaal Museum and Burgers Park in 1949</b> (UP Repository) . . . . .	15	<b>Figure 2.1.50: 19 Tulleken Street in 2017</b> (Author 2017) . . . . .	30	<b>Figure 2.2.4: Site amenities relevant to tourists</b> (Author 2017) . . . . .	41
<b>Figure 2.1.18: 21 Tulleken Street in 1990</b> (le Roux 1990:160). . . . .	15				
<b>Figure 2.1.19: 21 Tulleken Street in 2009</b> (Google Earth 2017). . . . .	15				
<b>Figure 2.1.20: Elevation of Tulleken Street</b> (Author 2017) . . . . .	16				
<b>Figure 2.1.21: Site plan labelling the existing functions</b> (Author 2017) . . . . .	16				
<b>Figure 2.1.22: Mapping of tenants/ owners residing in the houses</b> (Author 2017). . . . .	18				
<b>Figure 2.1.23: Mapping of amount of years that the residents have been living in specific houses</b> (Author 2017). . . . .	18				
<b>Figure 2.1.24: Mapping of the ages of residents</b> (Author 2017) . . . . .	19				
<b>Figure 2.1.25: Mapping of the race of residents</b> (Author 2017) . . . . .	19				
<b>Figure 2.1.26: Mapping of activities in the area</b> (Author 2017) . . . . .	19				
<b>Figure 2.1.27: Layout of existing social conditions in the area</b> (Author 2017). . . . .	21				
<b>Figure 2.1.28: Solar study generated through Revit 2017</b> (Author 2017). . . . .	21				
<b>Figure 2.1.29: A view of Tulleken street</b> (Author 2017) . . . . .	22				
<b>Figure 2.1.30: A view of Rider Haggard street</b> (Author 2017) . . . . .	22				
<b>Figure 2.1.31: Plan and section of the sidewalk</b> (Author 2017) . . . . .	22				



<b>Figure 2.2.5:</b> Tourist routes and activity (Author 2017) . . . . .	41	<b>Figure 4.13:</b> A historic house in Hoi An's main street (Author 2014) . . . . .	67	<b>Figure 4.34:</b> Map of amenities (ArchDaily 2014) 72		<b>key structures (Author 2017) . . . . .</b>	89
<b>Figure 2.2.6:</b> Route from Gautrain to site (Author 2017) . . . . .	43	<b>Figure 4.14:</b> The view down a pedestrian street (Author 2014) . . . . .	67	<b>Figure 4.35:</b> Interior view of information centre (ArchDaily 2014) . . . . .	72	<b>Figure 5.2.5:</b> Restaurant venue and public ablutions perspective (Author 2017) . . . . .	91
<b>Figure 2.2.7:</b> Visual mapping of route (Author 2017) . . . . .	43	<b>Figure 4.15:</b> Historic houses converted into clothing shops (Author 2014) . . . . .	67	<b>Figure 4.36:</b> Exterior view of temporary structures (ArchDaily 2014) . . . . .	72	<b>Figure 5.2.6:</b> Tuckshop and take-aways exterior perspective (Author 2017) . . . . .	91
<b>Figure 2.2.8:</b> Site key plan (Author 2017) . . . . .	44	<b>Figure 4.16:</b> A decorative brick (Author 2014) . . . . .	67	<b>Figure 4.37:</b> The view of the Mandela House in Vilikazi street (Gauteng 2017) . . . . .	73	<b>Figure 5.2.7:</b> Youth hostel exterior perspective (Author 2017) . . . . .	91
<b>Figure 2.2.9:</b> The profile of the model tourist (Author 2017) . . . . .	46	<b>Figure 4.17:</b> The effects of tourism evaluated for the Bo-Kaap (Author 2017) . . . . .	68	<b>Figure 4.38:</b> View of Vilakazi Street (Mapio) . . . . .	73	<b>Figure 5.2.8:</b> Degrees of privacy (Author 2017) 92	
<b>Figure 2.2.3:</b> Route from Gautrain to site (Author 2017) . . . . .	46	<b>Figure 4.18:</b> The effects of tourism evaluated for Hoi-An (Author 2017) . . . . .	68	<b>Figure 4.39:</b> Type C2 House plan, dated 1944 (Joburg 2008) . . . . .	73	<b>Figure 5.2.9:</b> Layout of the social strategy (Author 2017) . . . . .	92
<b>Figure 2.2.4:</b> Visual mapping of route (Author 2017) . . . . .	46	<b>Figure 4.19:</b> Exhibition area (Architecture Norway 2009) <b>Figure 4.20:</b> New concrete interior walkway (Divisare 2016) . . . . .	69	<b>Figure 4.40:</b> Exterior entrance view (ArchDaily 2016) . . . . .	74	<b>Figure 5.2.10:</b> Strategy for the trees on the site (Author 2017) . . . . .	94
<b>Figure 2.2.10:</b> The profile of the model community member (Author 2017) . . . . .	46	<b>Figure 4.21:</b> Interior walkway (Architecture Norway 2009) . . . . .	69	<b>Figure 4.41:</b> Main entrance (ArchDaily 2016) . . . . .	74	<b>Figure 5.2.11:</b> Palette A: Collage of existing material, form and colour (Author 2017) . . . . .	97
<b>Figure 3.1 Chapter cover page:</b> Conceptual drawing of theoretical overlaps (Author 2017) . . . . .	51	<b>Figure 4.22:</b> New windows (Architecture Norway 2009) . . . . .	69	<b>Figure 4.42:</b> Exhibition space (ArchDaily 2016) . . . . .	74	<b>Figure 5.2.12:</b> Palette B: Collage of new material, form and colour (Author 2017) . . . . .	97
<b>Figure 4.1 Chapter cover page:</b> Conceptual collage of Hoi An and the Bo-Kaap (Author 2017) . . . . .	63	<b>Figure 4.23:</b> Display of artefacts (CMU Architecture Scandinavia 2010) . . . . .	69	<b>Figure 4.43:</b> Interior views of the information centre with a new seat built into an existing opening (ArchDaily 2016) . . . . .	74	<b>Figure 5.2.13:</b> Pattern development (Author 2017) . . . . .	98
<b>Figure 4.2:</b> The Bo-Kaap marked on a map of Cape Town (Maps Company 2014) . . . . .	65	<b>Figure 4.24:</b> A view of the interior circulation space (Archdaily 2011) . . . . .	70	<b>Figure 5.1 Chapter cover page:</b> Conceptual collage of the old as opposed to the new (Author 2017) . . . . .	79	<b>Figure 5.2.14:</b> Collage of patterns found on the interior (Author 2017) . . . . .	98
<b>Figure 4.3:</b> The transition of space from public to private (Maps Company 2014) . . . . .	65	<b>Figure 4.25:</b> Views of the interior exhibition space (Kardorff) . . . . .	70	<b>Figure 5.1.3:</b> Wooden and masonry built-in fireplaces (Author 2017) . . . . .	80	<b>Figure 5.2.15:</b> A screen panel, not to scale (Author 2017) . . . . .	99
<b>Figure 4.4:</b> The Batavia Cafe in Rose Street (Author 2017) . . . . .	65	<b>Figure 4.26:</b> New concrete set against an original brick wall (Archdaily 2011) . . . . .	70	<b>Figure 5.1.1:</b> Stained glass windows in wooden frames (Author 2017) . . . . .	80	<b>Figure 5.2.16:</b> Exploded view of the restaurant venue, not to scale (Author 2017) . . . . .	99
<b>Figure 4.5:</b> View from the top of Wale Street (Author 2017) . . . . .	65	<b>Figure 4.27:</b> Views of the interior exhibition space (Archdaily 2011) . . . . .	70	<b>Figure 5.1.2:</b> Arched doorways and columns (Author 2017) . . . . .	80	<b>Figure 5.2.17:</b> Initial site plan, June 2017 (Author 2017) . . . . .	101
<b>Figure 4.6:</b> Biesmielah Restaurant (Author 2017) 65		<b>Figure 4.28:</b> Street facing exterior view (Archi-Travel 2015) . . . . .	71	<b>Figure 5.1.4:</b> Pitched sheet metal roofs (Author 2017) . . . . .	81	<b>Figure 5.2.18:</b> Initial floor plan, June 2017 (Author 2017) . . . . .	101
<b>Figure 4.7:</b> An alteration in Dorp Street (Author 2017) . . . . .	65	<b>Figure 4.29:</b> Kitchen interior (Archdaily 2010) . . . . .	71	<b>Figure 5.1.5:</b> Floor finishes (Author 2017) . . . . .	81	<b>Figures 5.2.19:</b> Conceptual development through models (Author 2017) . . . . .	102
<b>Figure 4.8:</b> The view of Chiappini Street (Author 2017) . . . . .	65	<b>Figure 4.30:</b> Horsefeathers Thirteen-VII, 1976, Robert Rauschenberg (Artsy 2017) . . . . .	71	<b>Figure 5.1.6:</b> The shape of a traditional house is simplified (Author 2017) . . . . .	81	<b>Figure 5.3.1:</b> Floor inlay, Castelvecchio (ArchiObjects 2014) . . . . .	105
<b>Figure 4.9:</b> Different sidewalk and road materials (Author 2017) . . . . .	65	<b>Figure 4.31:</b> Street facing hand-drawn elevation (Archdaily 2010) . . . . .	71	<b>Figure 5.1.7:</b> Tourist specific functional layout (Author 2017) . . . . .	83	<b>Figure 5.3.2:</b> Final site plan, . . . . .	106
<b>Figure 4.10:</b> Interior view of the Bo-Kaap Museum (Author 2017) . . . . .	65	<b>Figure 4.32:</b> Concept diagram (ArchDaily 2014) 72		<b>Figure 5.2.1:</b> Conceptual Sketches (Author 2017) 86		<b>Figure 5.3.3:</b> Youth hostel first floor plan, . . . . .	107
<b>Figure 4.11:</b> A tourist map of the ancient village of Hoi An (World Heritage Site 2010) . . . . .	67	<b>Figure 4.33:</b> Axonometric concept diagram (ArchDaily 2014) . . . . .	72	<b>Figure 5.2.2:</b> Envisioned atmosphere (Author 2017) . . . . .	86	<b>Figure 5.3.4:</b> Ground floor plans, . . . . .	107
<b>Figure 4.12:</b> Protection Plan, dating from 1998 (UNESCO) . . . . .	67			<b>Figure 5.2.3:</b> Urban vision for site (Author 2017) . . . . .	89	<b>Figure 5.3.5:</b> 15 -23 Tulleken Northern elevation	

<i>(East to West), not to scale (Author 2017)</i> . . . . .	108	<b>Figure 5.3.24:</b> <i>Fixing detail by Carlo Scarpa (Albertini and Bagnoli 1988:61)</i> . . . . .	120	<i>tive (Author 2017)</i> . . . . .	127	<b>Figure 5.3.63:</b> <i>Bar detail layout (Author 2017)</i>	140
<b>Figure 5.3.6:</b> <i>15 - 21 Tulleken Southern elevation (West to East), not to scale (Author 2017)</i> . . . . .	108	<b>Figure 5.3.25:</b> <i>Balustrade detail elevation (Author 2017)</i> . . . . .	120	<b>Figure 5.3.44:</b> <i>Exhibition detail layout plan, not to scale (Author 2017)</i> . . . . .	128	<b>Figure 5.3.64:</b> <i>Restaurant kitchen detail layout (Author 2017)</i> . . . . .	140
<b>Figure 5.3.7:</b> <i>Section A: East - West, not to scale (Author 2017)</i> . . . . .	109	<b>Figure 5.3.26:</b> <i>Balustrade detail section (Author 2017)</i> . . . . .	120	<b>Figure 5.3.45:</b> <i>Exploded axonometric view of an exhibition stand (Author 2017)</i> . . . . .	128	<b>Figure 5.3.65:</b> <i>Tuckshop detail layout, not to scale (Author 2017)</i> . . . . .	142
<b>Figure 5.3.8:</b> <i>Youth hostel detail 2, not to scale (Author 2017)</i> . . . . .	109	<b>Figure 5.3.27:</b> <i>Exploded axonometric balustrade view (Author 2017)</i> . . . . .	120	<b>Figure 5.3.46:</b> <i>Exhibition stand Section A, not to scale (Author 2017)</i> . . . . .	129	<b>Figure 5.3.66:</b> <i>Tuckshop section, not to scale (Author 2017)</i> . . . . .	142
<b>Figure 5.3.9:</b> <i>Youth hostel detail 3, not to scale (Author 2017)</i> . . . . .	109	<b>Figure 5.3.28:</b> <i>Youth hostel staircase and platform lift layout plan, not to scale (Author 2017)</i> . . . . .	121	<b>Figure 5.3.47:</b> <i>Exhibition stand Section B, not to scale (Author 2017)</i> . . . . .	129	<b>Figure 5.3.67:</b> <i>Roof construction detail, not to scale (Author 2017)</i> . . . . .	142
<b>Figure 5.3.10:</b> <i>Youth hostel gutter detail 4, not to scale (Author 2017)</i> . . . . .	109	<b>Figure 5.3.29:</b> <i>Exploded axonometric view of the staircase (Author 2017)</i> . . . . .	121	<b>Figure 5.3.48:</b> <i>Exhibition stand Detail Section 2, not to scale (Author 2017)</i> . . . . .	130	<b>Figure 5.3.68:</b> <i>Tuckshop and take-aways exterior perspective (Author 2017)</i> . . . . .	142
<b>Figure 5.3.11:</b> <i>Section C: Youth Hostel (North - South), not to scale (Author 2017)</i> . . . . .	111	<b>Figure 5.3.30:</b> <i>The RB 150 open platform lift (Author 2017)</i> . . . . .	121	<b>Figure 5.3.49:</b> <i>Exhibition stand Detail Section 3, not to scale (Author 2017)</i> . . . . .	130	<b>Figure 5.3.69 - 5.3.74:</b> <i>Furniture specifications (reference as indicated)</i> . . . . .	144
<b>Figure 5.3.12:</b> <i>Youth Hostel Detail 5, not to scale (Author 2017)</i> . . . . .	112	<b>Figure 5.3.31:</b> <i>Staircase detail, not to scale (Author 2017)</i> . . . . .	122	<b>Figure 5.3.50:</b> <i>New window opening Detail Section 4, not to scale (Author 2017)</i> . . . . .	130	<b>Figure 6.1 Chapter cover image:</b> <i>Initial hand drawn elevation overlaid with final elevation of Tulleken Street (Author 2017)</i> . . . . .	151
<b>Figure 5.3.13:</b> <i>Youth Hostel Detail 6, not to scale (Author 2017)</i> . . . . .	112	<b>Figure 5.3.32:</b> <i>Staircase elevation, not to scale (Author 2017)</i> . . . . .	122	<b>Figure 5.3.51:</b> <i>New window opening Section C, not to scale (Author 2017)</i> . . . . .	130	<b>Figure 6.2:</b> <i>NZASM branding concept (Author 2017)</i> . . . . .	152
<b>Figure 5.3.14:</b> <i>Youth Hostel Detail 7, not to scale (Author 2017)</i> . . . . .	112	<b>Figure 5.3.33:</b> <i>Youth hostel first floor interior perspective (Author 2017)</i> . . . . .	122	<b>Figure 5.3.52:</b> <i>Conceptual development of the information office (Author 2017)</i> . . . . .	131		
<b>Figure 5.3.15:</b> <i>Precinct approach exterior perspective (Author 2017)</i> . . . . .	112	<b>Figure 5.3.34:</b> <i>Conceptual development of the reception counter (Author 2017)</i> . . . . .	124	<b>Figure 5.3.53:</b> <i>Information office interior perspective (Author 2017)</i> . . . . .	131		
<b>Figure 5.3.16:</b> <i>Section D: Tourist information, restaurant, bar and ablutions (South - North), not to scale (Author 2017)</i> . . . . .	115	<b>Figure 5.3.35:</b> <i>Reception area interior perspective (Author 2017)</i> . . . . .	124	<b>Figure 5.3.54:</b> <i>Information office detail layout plan, not to scale (Author 2017)</i> . . . . .	132		
<b>Figure 5.3.17:</b> <i>View of the portal frames and walkway (Author 2017)</i> . . . . .	116	<b>Figure 5.3.36:</b> <i>Reception detail layout plan, not to scale (Author 2017)</i> . . . . .	125	<b>Figure 5.3.55:</b> <i>Exploded axonometric view of the self-help kiosk (Author 2017)</i> . . . . .	132		
<b>Figure 5.3.18:</b> <i>Progression in 3D development of the youth hostel's street facing facade (Author 2017)</i> . . . . .	116	<b>Figure 5.3.37:</b> <i>Reception counter Section A, not to scale (Author 2017)</i> . . . . .	125	<b>Figure 5.3.56:</b> <i>Self-help kiosk Section A, not to scale (Author 2017)</i> . . . . .	133		
<b>Figure 5.3.19:</b> <i>Youth hostel exterior perspective (Author 2017)</i> . . . . .	116	<b>Figure 5.3.38:</b> <i>Reception counter Section B, not to scale (Author 2017)</i> . . . . .	126	<b>Figure 5.3.57:</b> <i>Self-help kiosk Section B, not to scale (Author 2017)</i> . . . . .	133		
<b>Figure 5.3.20:</b> <i>Conceptual development of the staircase (Author 2017)</i> . . . . .	118	<b>Figure 5.3.39:</b> <i>Reception counter Section C, not to scale (Author 2017)</i> . . . . .	126	<b>Figure 5.3.58:</b> <i>Brochure display view (Author 2017)</i> . . . . .	134		
<b>Figure 5.3.21:</b> <i>Conceptual development of the balustrade (Author 2017)</i> . . . . .	119	<b>Figure 5.3.40:</b> <i>Reception counter Section D, not to scale (Author 2017)</i> . . . . .	126	<b>Figure 5.3.59:</b> <i>Brochure display Section C, not to scale (Author 2017)</i> . . . . .	134		
<b>Figure 5.3.22:</b> <i>Balustrade elevation, not to scale (Author 2017)</i> . . . . .	119	<b>Figure 5.3.41:</b> <i>Detail Section 1, not to scale (Author 2017)</i> . . . . .	126	<b>Figure 5.3.60:</b> <i>Brochure display Section D, not to scale (Author 2017)</i> . . . . .	134		
<b>Figure 5.3.23:</b> <i>Entrance bridge to the Querini Stampalia Foundation, Venice (Mimoa 2017)</i> . . . . .	120	<b>Figure 5.3.42:</b> <i>Conceptual development of the exhibition system (Author 2017)</i> . . . . .	127	<b>Figure 5.3.61:</b> <i>Brochure display Detail section 5, not to scale (Author 2017)</i> . . . . .	134		
		<b>Figure 5.3.43:</b> <i>Exhibition space interior perspective (Author 2017)</i> . . . . .	127	<b>Figure 5.3.62:</b> <i>Reflected ceiling plan and lighting layout, not to scale (Author 2017)</i> . . . . .	135		

## LIST OF DIAGRAMS

<b>Diagram 1.1:</b> Summary of research methodology (Author 2017) . . . . .	3
<b>Diagram 2.2.1:</b> The functional requirements of a tourist precinct (Author 2017) . . . . .	38
<b>Diagram 2.2.2:</b> The requirements of a tourist visiting for an hour and a day (Author 2017) . . . . .	38
<b>Diagram 3.1.1:</b> Brooker and Stone's strategies for alteration (2004:79) . . . . .	53
<b>Diagram 3.1.2:</b> The conservation processes as outlined in the Burra Charter (2013:6) . . . . .	53
<b>Diagram 3.1.3:</b> Scott's approaches to alteration (2008) . . . . .	53
<b>Diagram 3.1.4:</b> The combined strategy to heritage alteration (Author 2017) . . . . .	53
<b>Diagram 3.2.1:</b> Measurements of urban resilience (Suarez et al. 2016:3) . . . . .	55
<b>Diagram 3.2.2:</b> Community sustainability is compared to resilience (Lew et al. 2016:22) . . . . .	55
<b>Diagram 3.3.1:</b> The creation of a place's identity (Author 2017) . . . . .	56
<b>Diagram 3.3.2:</b> A summary of the meaning of sustainable tourism (Author 2017) . . . . .	56
<b>Diagram 3.3.3:</b> Tourism as the link (Author 2017)	
<b>Diagram 3.3.4:</b> The cultural and heritage tourist as viable target market (Ursache 2015:135) . . . . .	57
<b>Diagram 3.4.1:</b> The regeneration strategy (Author 2017) . . . . .	58
<b>Diagram 4.1:</b> Summary of case study conservation strategies (Author 2017) . . . . .	75
<b>Diagram 4.2:</b> Summary of heritage precedents (Author 2017) . . . . .	75
<b>Diagram 5.1.1:</b> Summary of form extracted from analysis in Figure 5.1.1 - 5.1.6 (Author 2017) . . . . .	82
<b>Diagram 5.1.2:</b> Summary of informants from the context study (Author 2017) . . . . .	82
<b>Diagram 5.1.3:</b> Functional requirements of a tourist precinct (Author 2017) . . . . .	83
<b>Diagram 5.1.4:</b> A combined strategy to heritage alteration (Author 2017) . . . . .	84

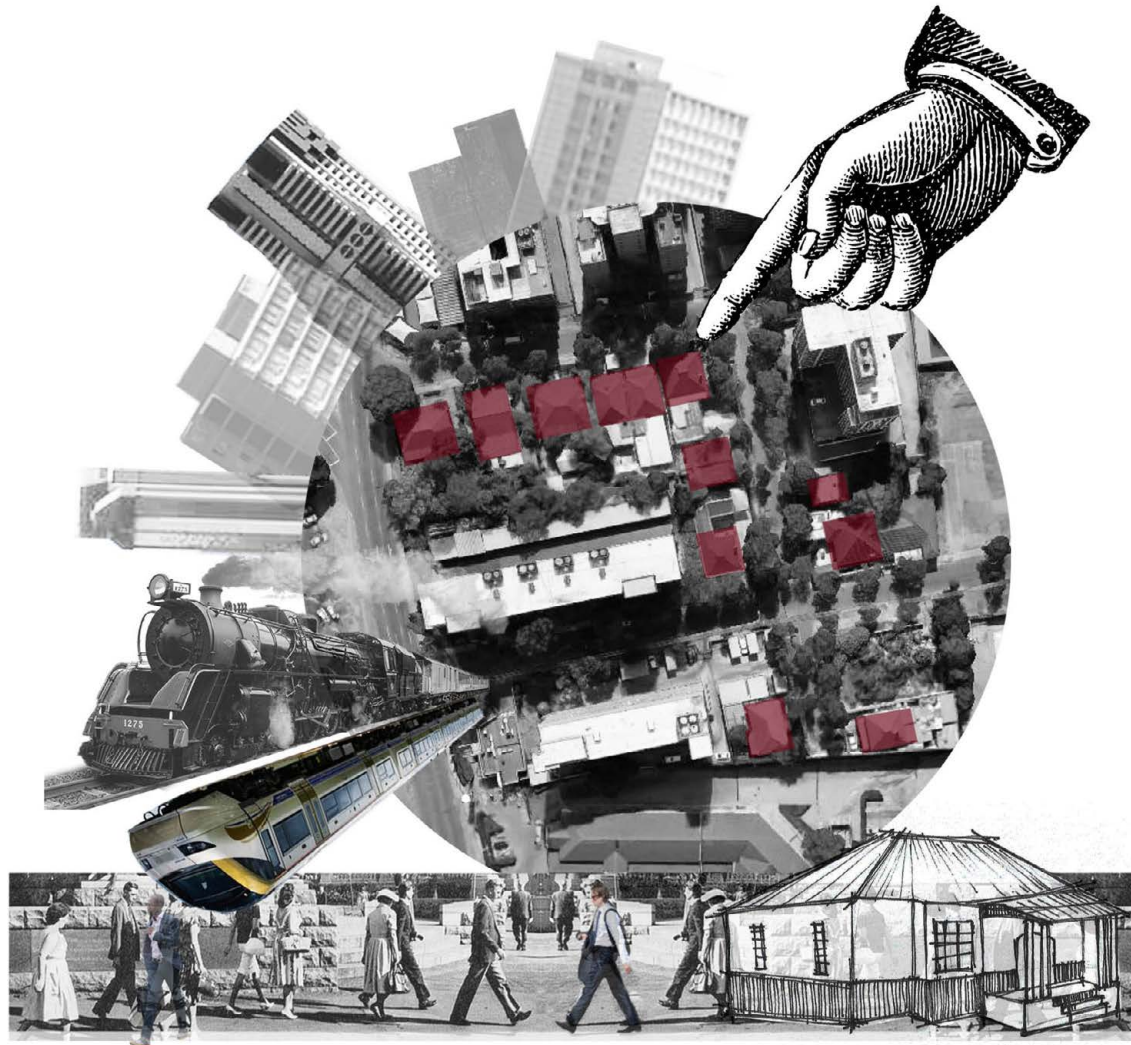
<b>Diagram 5.1.5:</b> The regeneration strategy (Author 2017) . . . . .	84
<b>Diagram 5.1.6:</b> Summary of case study conservation strategies (Author 2017) . . . . .	85
<b>Diagram 5.1.7:</b> Summary of heritage precedents (Author 2017) . . . . .	85
<b>Diagram 5.2.1:</b> The principles of shared private drives summarised (Author 2017) . . . . .	91
<b>Diagram 5.2.2:</b> Principles of the design of public space summarised (Author 2017) . . . . .	91
<b>Diagram 5.2.3:</b> Summary of the old/existing/original material (Author 2017) . . . . .	95
<b>Diagram 5.2.4:</b> Summary of the materiality of past additions (Author 2017) . . . . .	95
<b>Diagram 5.2.5:</b> Summary of the materiality of new additions (Author 2017) . . . . .	95
<b>Diagram 5.3.1:</b> Conceptual idea regarding the contents of the exhibition (Author 2017) . . . . .	127
<b>Diagram 5.3.2:</b> Kitchen process diagram (Author 2017) . . . . .	140

## LIST OF TABLES

<b>Table 2.2.1:</b> The programmatic layout of the tourism functions (Author 2017) . . . . .	44
<b>Table 5.3.1:</b> Ceiling legend (Author 2017) . . . . .	136
<b>Table 5.3.2:</b> Lighting legend (Author 2017). . . . .	136
<b>Table 5.3.3:</b> Lighting calculation for Area A: NZASM Exhibition (Author 2017) . . . . .	137
<b>Table 5.3.3:</b> Lighting calculation for Area A: NZASM Exhibition (Author 2017) . . . . .	138
<b>Table 5.3.5:</b> Lighting calculation for Area C: Tourist Information Office (Author 2017) . . . . .	139
<b>Table 5.3.6:</b> Green Star SA Interiors v1 Score Sheet (Author 2017) . . . . .	146



# CHAPTER 1: INTRODUCTION





## 1.1 INTRODUCTION

The number of single-family residences in the Nederlandsche Zuid-Afrikaansche Spoorweg-Maatschappij (NZASM) heritage area, to the east of the Pretoria Train Station, have decreased over recent years (refer to the historical timeline of the area in Section 2.1.4, in Chapter 2). Due to the pressures of the Tshwane Compaction and Densification Strategy (2005:1), its aim being to densify the structural composition of the metropolitan area as a whole, and the addition of high-rise apartment blocks positioned between the houses, the area's density is certain to increase further, and the future of these heritage structures are in jeopardy. A fragmented urban environment has resulted, which is further emphasised by the discrepancy in scale and density of the built structures.

The aim of this study is to provide a regeneration strategy for the site as a method of ensuring the continued existence of the structures. The strategy will result in a change in function of some of the dwellings and an approach to the alteration of the heritage fabric. The following chapter sets the scene for the design proposal, with the problem statement and research questions set out; the objectives, significance, delineations and limitations of the study explained; and the qualitative research methods described.

## 1.2 BACKGROUND

Most of the structures built around the beginning of the 20th century to the south of Church Square in Pretoria were related to the establishment of the Nederlandsche Zuid-Afrikaansche Spoorweg-Maatschappij (NZASM). The extensive railway yard and housing development provided for the railway personnel, gave infrastructure to the South and introduced a new architectural typology to Pretoria (de Jong 1990:53).

These NZASM houses were built in the area known today as Salvokop and stretch from the South to the East, up to the Apies River. A few standard typologies were used throughout the country, namely Type A – C, with the choice of design dictated by the occupant's rank, type of work and marital status (de Jong 1990:55).

The physical context of this study is the residential area in and around Tulleken, Rider Haggard and Clara streets in the Salvokop district. Only around ten of the original railway houses still remain. These have been altered in varying degrees to suit the needs of their occupants. Many of the residents have lived in their homes for up to half a century and form an important part of the living cultural significance of the area.

As observed by Schalk le Roux (1990:162), the future of the houses is unsure due to economic pressures. This statement is even more relevant in the present day. One of the aims of the Tshwane Compaction and Densification Strategy is to create compact and densified residential environments around transport and activity nodes (2005:7), of which the Pretoria Train Station and Gautrain station are examples. The natural conclusion would be to encourage the well-located site to become a high-density residential area, but the historic fabric and cultural value of the railway houses would be lost.

The community on site has developed since 1994 into a diverse mix of residents, in terms of age, nationality, language and culture. Not only does a strong sense of community exist between the residents of the houses, but a larger overarching sense of familiarity and acceptance exists between all the residents in the area. This successful co-habitation is something to preserve, build on and celebrate.

**Figure 1.1 Chapter cover page:** *Conceptual collage of the site (Author 2017)*

### 1.3 PROBLEM STATEMENT

A catalyst is required to acknowledge and celebrate the cultural significance of the historical residential structures located to the east of the Pretoria Train Station, in the NZASM heritage area. Tourism plug-ins are proposed as such a potential catalyst, with the choice of catalyst being informed by the site's prime location with relation to tourist attractions, public transport and the requirement for tourist information. The site also offers tourism opportunities as set out in the Tshwane Inner City Regeneration Programme (Department of Public Works 2015). The programme consists of an action plan to stimulate investments, job creation and growth in line with the Tshwane Vision 2055 (Department of Public Works 2015). The envisioned outcomes of the introduction of the catalyst are to support sustainable community development and resilience of the historic built structures and residential community.

### 1.4 RESEARCH QUESTIONS

Based on the aforementioned issues of densification, insensitive alteration of heritage fabric and regeneration requirement of the site, the following research questions were developed:

#### **Main research question:**

- How can the introduction of tourism act as a catalyst to acknowledge and celebrate the cultural significance of the NZASM houses and the area?

#### **Sub- research questions:**

- What design strategy can be generated from the historical significance of the NZASM houses? (Chapter 2)
- How can theories of resilience, sustainable community development and heritage tourism provide a regeneration strategy for the area? (Chapter 3)
- How can tourist activities be inserted into the historic fabric while still maintaining the cultural significance of the houses and the area? (Chapter 5).

### 1.5 AIM/OBJECTIVE

The aim of the study is to maintain the cultural and historical value of the NZASM heritage area through the regeneration of the area by means of the introduction of a tourist precinct. This is achieved through a proposed urban vision of a tourist precinct, with the design resolution of the adaptive reuse of certain historic dwellings. To this end, a specific approach, as identified from the research presented in Chapter 3, is taken to the heritage fabric. The overarching objective of the study is the stitching of the fragmented urban fabric from the interior outwards to form a cohesion between the community, houses and new tourist precinct.

### 1.6 SIGNIFICANCE OF STUDY

The study is significant in that the approach to the heritage fabric, and the assessment and articulation of cultural importance can be applied to similar heritage areas in South Africa. An outcome of the research is the formulation of design guidelines for ensuring the present-day relevance of historical domestic interiors, while minimising the deterioration of their historical and cultural value. The preservation of heritage is crucial, as historic city centres are the distinctive features of a city fostering identity and offering economic opportunities when carefully modernised (Spiekerman 2012:3). This study will aid in modernising a domestic section of Pretoria CBD.

Finally, the rigorous documentation and heritage assessment of the identified houses makes an archival contribution, which addresses the recommendations by Le Roux (1990:161) to analyse and document the specific site in terms of its architectural, cultural and urban features.



## 1.7 RESEARCH METHOD

A qualitative methodology is followed. More specifically, a multi-method approach with the focus on interpretation and meaning of the collected data in its context is used (Groat and Wang 2013:219). Diagram 1.1 provides a summary of the methodology.

The research methods include:

**Historical development:** The development of the area is tracked through historical maps and photos obtained from the University of Pretoria library's special collection, books on the history of Pretoria and consultation with experts in the field.

**Mapping:** The site and surrounding area is documented in terms of public amenities, transport and movement. A solar study is conducted for the site, specifically Tulleken, Rider Haggard and Clara Streets. The documentation of the site's physical qualities, for example boundaries, sidewalk conditions, and the route between the train station and site are also mapped.

**Informal discussions:** Data is collected from the community members living on site, through discussions during site visits. The topic of these discussions is focussed on historical and physical aspects of the respective resident's house, rather than personal details, thus by-passing any ethical issues.

**Documentation of the houses:** The houses are measured, drawn up and assessed from infor-

mation collected during site visits. The heritage features and physical condition of the houses are mapped, and alterations to the structures over time documented.

**Principles of the heritage charters:** The Burra Charter (ICOMOS 2013), an Australian charter that provides standards on conserving and managing places of cultural significance, is used as a guide to generate a statement of cultural significance for the area and the houses. This, in turn, serves as an informant in the generation of design guidelines for the project.

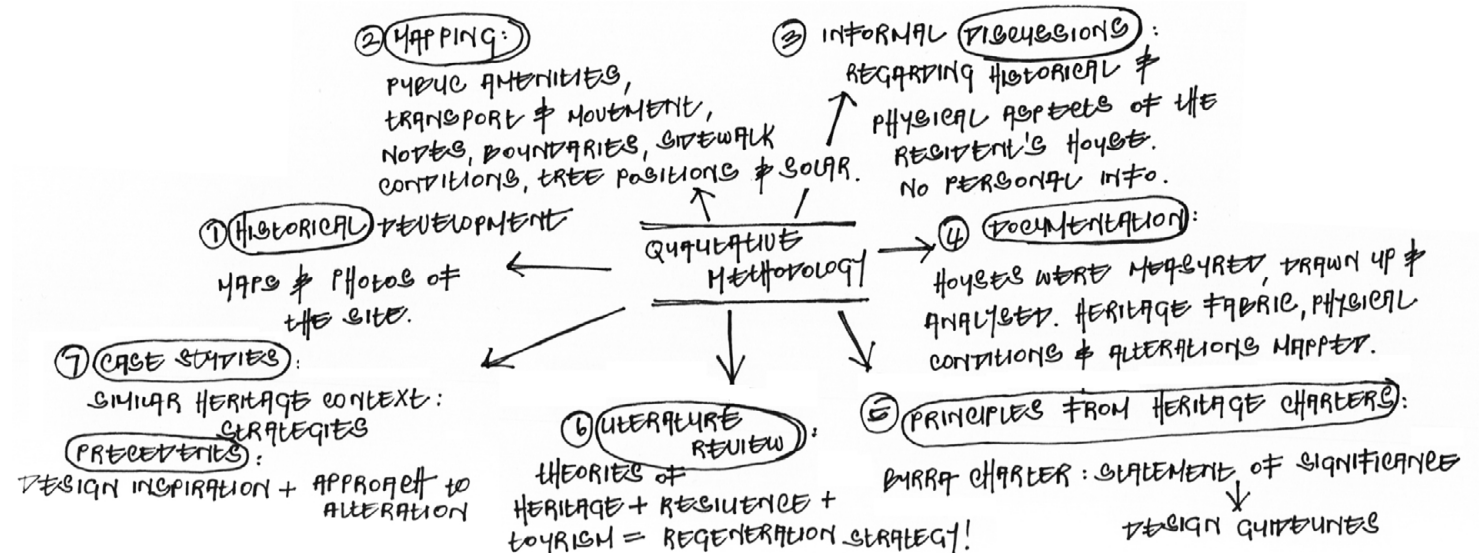
**Literature review:** A review of pertinent published works on theories of heritage, tourism and resilience is conducted in an endeavour to establish a sound theoretical underpinning to the problem and design proposal.

**Case studies and precedents:** Groat and Wang (2013:418) define a case study as an empirical enquiry that investigates a phenomenon or setting. Case studies that showcase similar heritage strategies are conducted to inform the design approach. The strategies used in the Bo-Kaap in Cape Town and the ancient town of Hoi An in

Vietnam are used as examples for this study.

As part of the case study approach, architects review precedent studies during the design process in an attempt to assess the knowledge gained by others, rather than to conduct research in the strict definition of the term (Groat and Wang 2013:68). International and local precedents in the fields of heritage tourism and alteration are studied and serve as design and technical informants for this study.

**Diagram 1.1:** Summary of research methodology (Author 2017)



## 1.8 DELINEATION AND LIMITATIONS

An urban vision of a tourist precinct in and around the NSAZM houses is proposed, with conceptual detail in terms of outdoor urban spaces. Strategically selected structures are resolved in technical detail, with the design focus and resolution of the study limited to the building interiors.

## 1.9 ASSUMPTIONS

Access was denied by the owners of 17, 21 and 23 Tulleken Street, with the result that certain assumptions have been made regarding these houses' interiors. These assumptions are justified through the documentation of houses in Tulleken and Rider Haggard Streets that have similar footprints and characteristics, and to which access was gained.

## 1.10 OVERVIEW OF STUDY

**Chapter 1** serves as an introduction to the study, the statement of the problem and research methods.

**Chapter 2** consists of a context study of the site, including mapping, documentation and analysis. A statement of cultural significance is developed through the guidelines from the heritage charters, as well as resulting design parameters.

**Chapter 3** establishes a theoretical base, by means of a literature review, including theories on heritage, tourism and resilience.

**Chapter 4** presents and analyses case studies and precedents as informants for the design approach.

**Chapter 5** illustrates the design concept, development and technical resolution.

**Chapter 6** concludes the study with an elaboration on the contribution of the design to the field of heritage and interior architecture, with further recommendations.

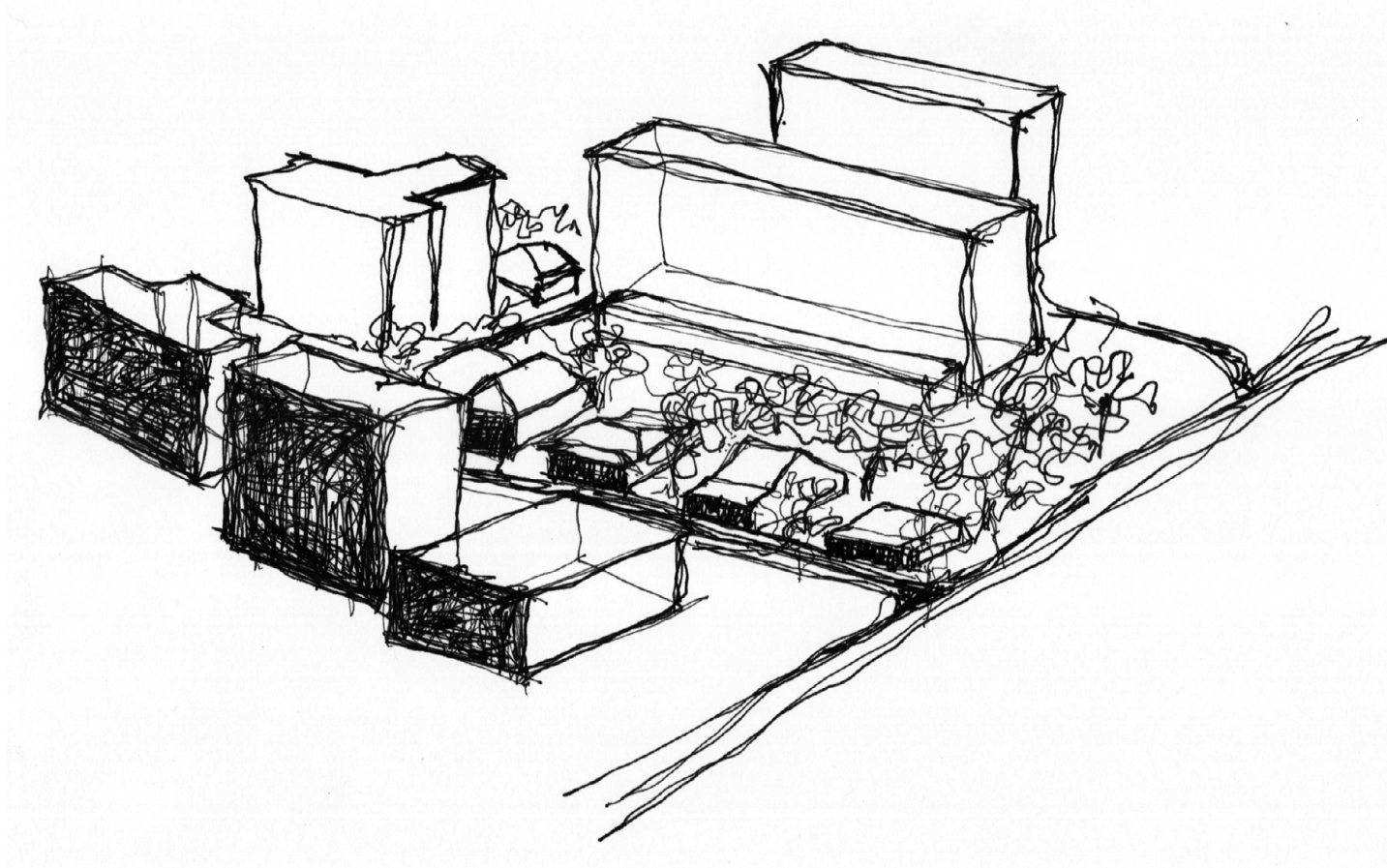
## 1.11 CONCLUSION

The focus of the study is on the holistic stitching of the urban fabric of the NZASM heritage area, rather than the design of small separate interior spaces. The area will be re-purposed from the 'inside out', with the interiors as the starting point. The intention is to lay the foundations for the development of sustainable tourism that can be managed by a resilient community.

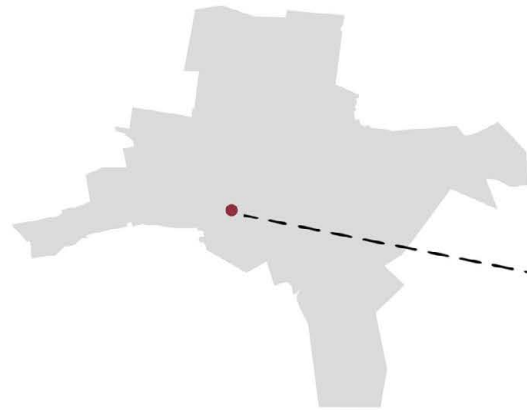




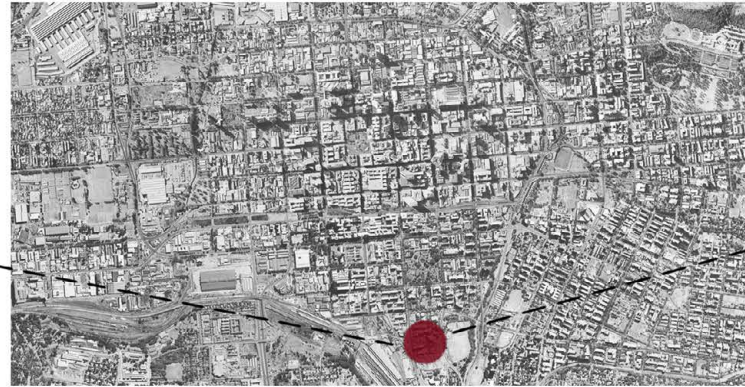
# CHAPTER 2: CONTEXT







2.1.1



2.1.2



2.1.3

# PART 1: CONTEXT ANALYSIS

## 2.1.1 CONTEXT INTRODUCTION

The context study makes use of multiple methods to investigate the physical and spatial attributes of the site.

The historical development of the area over time is explored; from its establishment as a residential area at the beginning of the 20th century to the present day. The site is analysed through information gathered from the community during informal discussions and an investigation into their movement patterns. The physical boundaries of the properties and the houses' relationship to the street, as well as the condition of the sidewalks in Tulleken and Rider Haggard Streets is assessed. The study is further supplemented with an investigation of the solar conditions within the area.

The analysis informs a general vision for the site, as well as the profile of the proposed model community member. The houses, where the main point of intervention is centred, are dealt with by means of an in-depth investigation of their heritage fabric, and their correlation to the Nederlandsche Zuid-Afrikaansche Spoorweg-Maatschappij (NZASM) housing types (see Figures 2.1.34 to 2.1.65). The section is concluded by a statement of significance.

Thereafter, the focus of this chapter turns to tourism, with the presentation of documentation on the existing tourist information office based at Church Square. The visual mapping of the pedestrian route from the train stations to the site,

with recommendations regarding its condition and accessibility, is also presented. The movement of tourists around the site, and to and from tourist attractions in and around the area, as well as the location of all amenities, is mapped. From this, the functional layout of a tourist precinct is proposed and a profile is created for the model tourist.

The chapter concludes with a set of design guidelines and objectives, including the identified opportunities and limitations drawn from the context study.

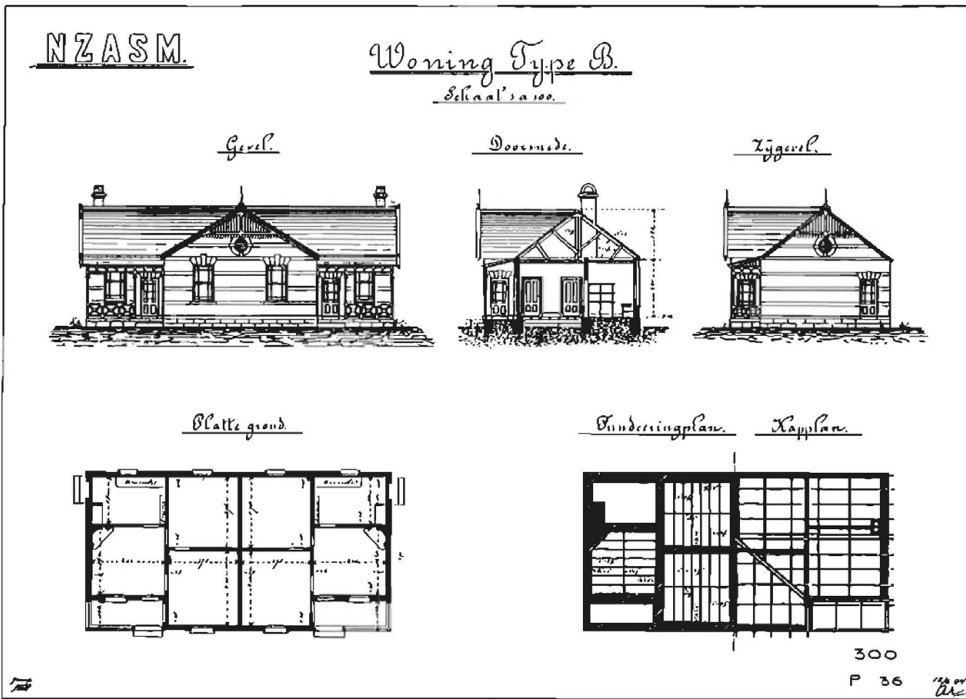
**Figure 2.1 Chapter Cover Page:** *Drawing of the site, viewed from a North-Western direction (Author 2017)*

**Figure 2.1.1:** *The location of the site in Pretoria (Author 2017)*

**Figure 2.1.2:** *The location of the site in the South Eastern Quadrant of Pretoria CBD (Author 2017)*

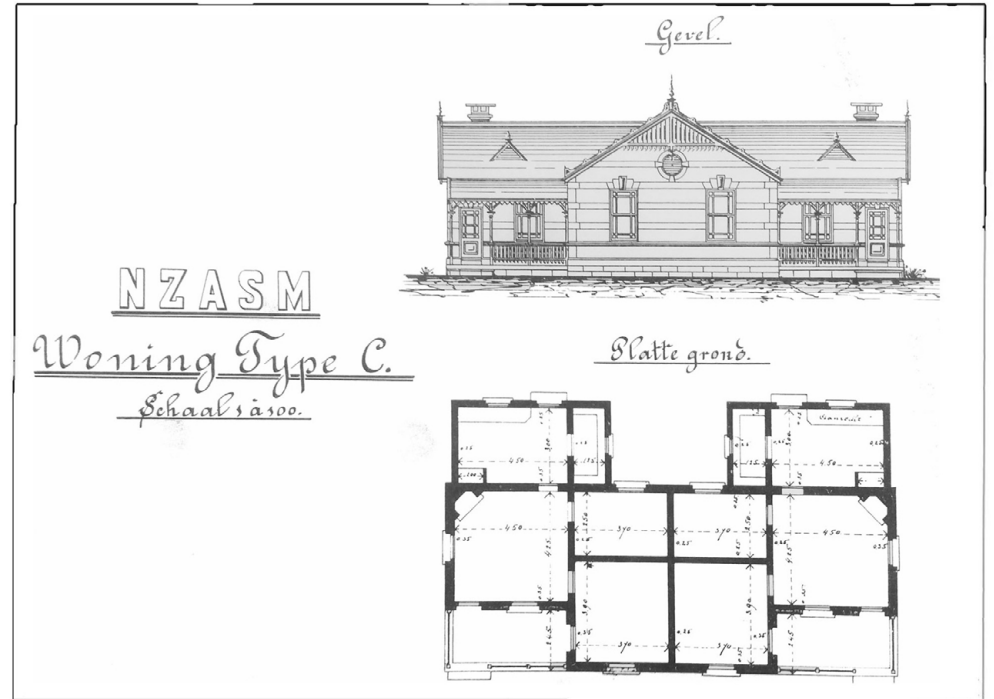
**Figure 2.1.3:** *The site consisting of Tulleken, Rider Haggard & Clara streets (Author 2017)*

2.1.4



2.1.6

2.1.5



2.1.7





2.1.8



2.1.9



2.1.10

## 2.1.2 HISTORICAL DEVELOPMENT OF THE AREA

Employee housing provided by the NZASM at the end of the nineteenth century can still be found in many areas of South Africa. The NZASM was a private Dutch enterprise founded in Amsterdam in 1887, tasked with establishing a Delgoa Bay line to Mozambique (De Jong 1990:53), which was crucial in the Paul Kruger Government's plan for economic development and autonomy (Bakker et al. 2014:143). By 1900, the NZASM was in control of most of South Africa's railway lines, and small housing settlements could be found around most of the train stations, for example in Pretoria Central, Volksrust, Waterval-Boven, Heidelberg and Komatiport. Towards the end of the nineteenth century, Paul Kruger's Government had recruited a host of skilled Dutch immigrants to drive infra-

structure development from Pretoria (Bakker et al. 2014:136). These Dutch architects' ideals and techniques gave shape to Pretoria's urban fabric. The Pretoria Train Station was established by the NZASM around 1892 (University of Pretoria 2012). Almost half of the white personnel employed by the NZASM were sent from Europe, where they were recruited and appointed by the company's Amsterdam head-office (De Jong 1990:53). The black NZASM personnel were recruited locally. During the Anglo-Boer War (1899-1902), the company's properties were confiscated by British authorities and most of the European personnel deported. In retaliation to this British interference, staff of the company, and the Boers, endeavoured to destroy and dismantle railway bridges, engines

and trucks that were now being used against them (Bakker et al. 2014:133). As a result, the NZASM was dissolved in 1908 (De Jong 1990:53).

Before its demise, the NZASM had constructed many houses for its employees. Standardised designs were developed by the company's construction department, or Dienst van Aanleg (De Jong 1990:54). In Pretoria, these houses were built to the south of the Pretoria Train Station, in the area now known as Salvokop. The railway management always sought higher ground to build their stations and housing compounds, determining the position of the NZASM establishment in relation to an existing town (Bakker et al. 2014:172). The planning dictated that property value would rise in the area between the railway and the town, leading to the

**Figure 2.1.4:** Plan and elevation of Type B semi-detached cottage, NZASM drawing dated 12 June 1894 (de Jong 1990:56)

**Figure 2.1.5:** Plan and elevation of Type C semi-detached cottage, NZASM drawing (de Jong 1988)

**Figure 2.1.6:** Elevation of Type C semi-detached cottage, NZASM-hof Salvokop Village (Dutch Footsteps 2016)

**Figure 2.1.7:** Elevation of Type C semi-detached cottage, NZASM Volksrust Railways Precinct (Dutch Footsteps 2016)

**Figure 2.1.8:** The street facing façade of NZASM House (ABLEWiki 2010)

**Figure 2.1.9:** Southern elevation (ABLEWiki 2010)

**Figure 2.1.10:** Postcard in colour printed by Braune & Levy, Johannesburg, no. 2122 depicting the Pretoria Train Station (UP Repository 2017)

decision to place staff housing on the other side of the railway tracks (Bakker et al. 2014:172). This also served as a social boundary, giving life to the stigma of living on the ‘wrong side of the tracks’.

Three main NZASM housing typologies were developed. Type A was a house resembling a barrack, with eight to twelve single rooms. This housing type was suitable for unmarried staff and accessible from a veranda on either side (De Jong 1990:55). Each room was equipped with a fireplace. Types B (see Figure 2.1.4) and C (see Figure 2.1.5) were semi-detached cottages or duet houses for married staff. Both types had a lounge, kitchen and two bedrooms, but the Type C houses were larger and had a pantry. None of the houses were without ornamentation. For example, coloured tiles in window arches and decorative ventilation louvres were a staple of their design (De Jong 1990:55). Types A – C were only available to white employees, while black staff, specifically in Pretoria, were housed in a long barrack located in a separate area (Bakker et al. 2014:173).

The houses to the east of the Pretoria Train Station loosely resemble the NZASM Types B and C in appearance, as well as in the organisation of layout and materials. Examples of materials are solid wooden plank floors, pressed copper ceilings, decorative ventilation bricks and built-in fireplaces.

De Jong (1985:13) states that many NZASM

employees, especially the higher-paid ones, lived outside of the Salvokop township in houses comparable to Melrose House. This statement is reinforced by Roger Fisher and Nicholas Clarke (2017), adding that the specific area likely became populated between 1910-1920 as railway officials bought land and built their own houses with the assistance of a NZASM fund. A well-known example of one of these houses is House van der Made, better known as NZASM House (see Figures 2.1.8 and 2.1.9). This house is located in Rissik Street and currently functions as a guest house. According to Sidney Mears (2017), an archaeologist and heritage consultant, the assumption can be made that the specific location of the residential area to the east of the Pretoria Train Station was determined by the location of the water supply to the Pretoria CBD. After the early 1890s water was fed along the streets in brick-lined furrows with slate covers and the seasonal Apies River (located close to the site) was canalised (Peres, Barker and Du Plessis 2015:2).

As graphically explained in the historical timeline (see Section 2.1.4 and Figures 2.1.12 to 2.1.19, in this chapter) the area where the studied NZASM houses are located originally developed from a farm owned by P. Mare to a low density residential area for railway officials established around 1910. Although an aerial photo from 1949 shows the area mainly populated by houses (see Figure

2.1.17), consolidated plots are visible on a map from 1979, indicating where the first apartment blocks were constructed (see Figure 2.1.16). The area’s density slowly rose over time and became culturally diverse after 1994. The demise of Salvokop and the area to the east of the Pretoria Train Station could hold relation to the perception that railway residences are low cost housing and located on an undesirable side of the railway tracks (Bakker et al. 2014:172). The nature of the urban fabric of the Pretoria CBD has also shifted in such a way that single family houses have no place in the dense city. The perception of these houses being ‘undesirable’ and the shift towards housing density has caused much of the memory of a time when being employed and housed by the railway was a desirable and prestigious position in South Africa.

### 2.1.3 SIMILAR HOUSING TYPOLOGY

Throughout Pretoria, many houses exist that are similar in typology to the houses to the east of the train station. The houses in Figure 2.1.11 have been identified as having a similar footprint when viewed in Google Earth (2017). They also have relatable features on the street-facing façade, for example:

- A symmetrical façade;
- A central veranda with cylindrical columns;
- Pitched sheet metal roofs; and
- A triangular roof cavity ventilation grille.

The specific typology, dating from around a hundred years ago, is also to be found in many South African towns. Especially in towns affiliated with the railways, where many type houses are still occupied and their original form visible under later additions (Bakker et al. 2014:133).

**Figure 2.1.11:** *Mapping of houses similar to the residential typology on site (all images Google Earth 2017)*

238 Flowers Street  
334 Flowers Street  
35 Margareta Street  
37 De Waal Street  
802 Church Street

**Capital Park**

326 Zeiler Street  
196 Blackwood Street

**Pretoria West**

184 4th Ave  
614 Reitz Street

**Salvokop**

16th Ave  
150 Melville Street

**Sunnyside**

6 Read Ave  
20 Read Ave  
137 Berea Street  
81 Gerhard Moerdyk Street  
92 Gerhard Moerdyk Street

**Pretoria Central - Berea North**

**Pretoria Central - Unisa Campus**

**Trevenna**

Google Earth

## 2.1.4 HISTORICAL TIMELINE OF THE AREA

The following timeline depicts the historic development of the residential area to the south of Church Square, related closely to the establishment of the Pretoria Train Station.



2.1.12

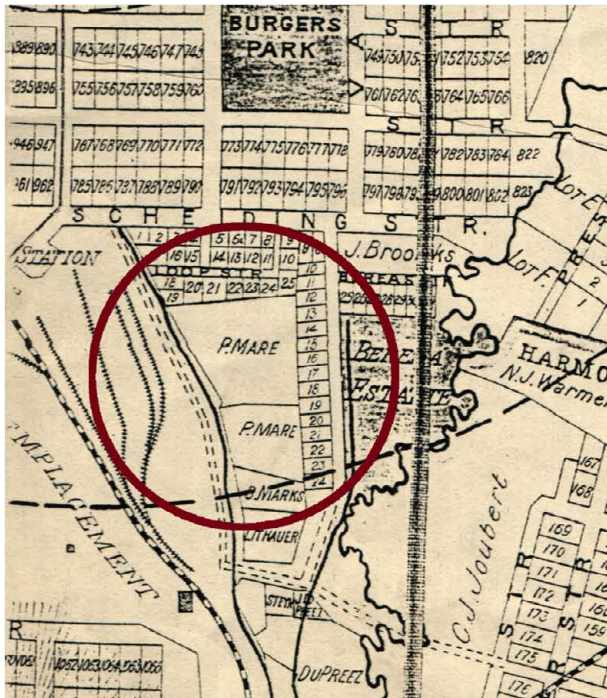
The area originated as a farm belonging to P. Mare. The train station is located to the west, established in 1892.

**Figure 2.1.12:** A view of Pretoria from South of the railway station (in the foreground), dating from late 1890's (Centenary Album 1953:87)

**Figure 2.1.13:** Compass sketch plan of Pretoria Transvaal in 1879 (Van der Waal Collection)

**Figure 2.1.14:** The layout of Pretoria's plots in 1902 (Van der Waal Collection).

**Figure 2.1.15:** The layout of Pretoria's plots, date unknown (Van der Waal Collection, map provided by J. Swart, 2016)



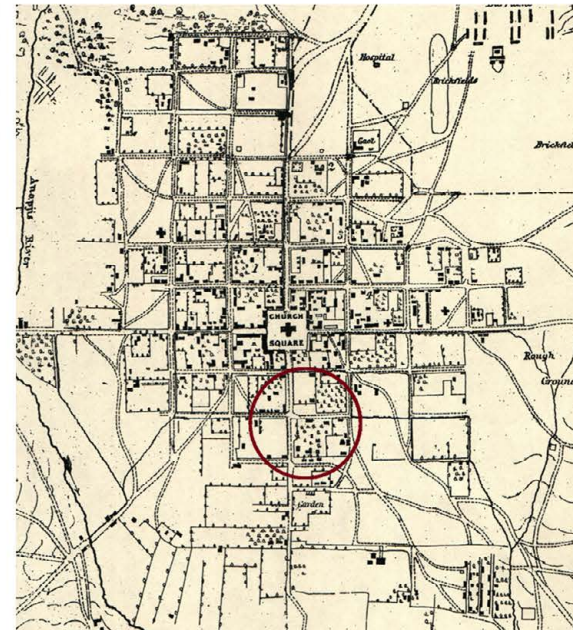
2.1.14

1879

1890

1902

The area to the south of Church Square is still undeveloped.



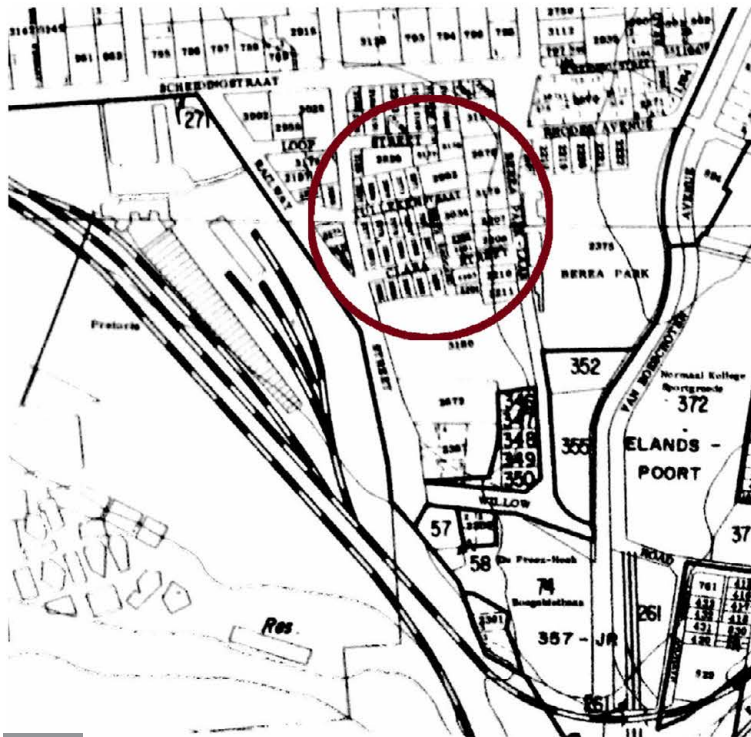
2.1.13

1900-1920: A residential area had been laid out to house employees of the NZASM.



2.1.15

Consolidated plots to accommodate high density apartment blocks are visible.



2.1.16

The remaining houses were still in a very good condition in 1990.



2.1.18

19  
49

19  
79

19  
90



The area is populated with single family residences.

2.1.17

The physical condition of the houses have deteriorated over time.



2.1.19

**Figure 2.1.16:** *The layout of Pretoria's plots, 1979 (Van der Waal Collection 2016)*

**Figure 2.1.17:** *An aerial photograph of Paul Kruger Street, showing the city hall, the Transvaal Museum and Burgers Park in 1949 (UP Repository)*

**Figure 2.1.18:** *21 Tulleken Street in 1990 (le Roux 1990:160).*

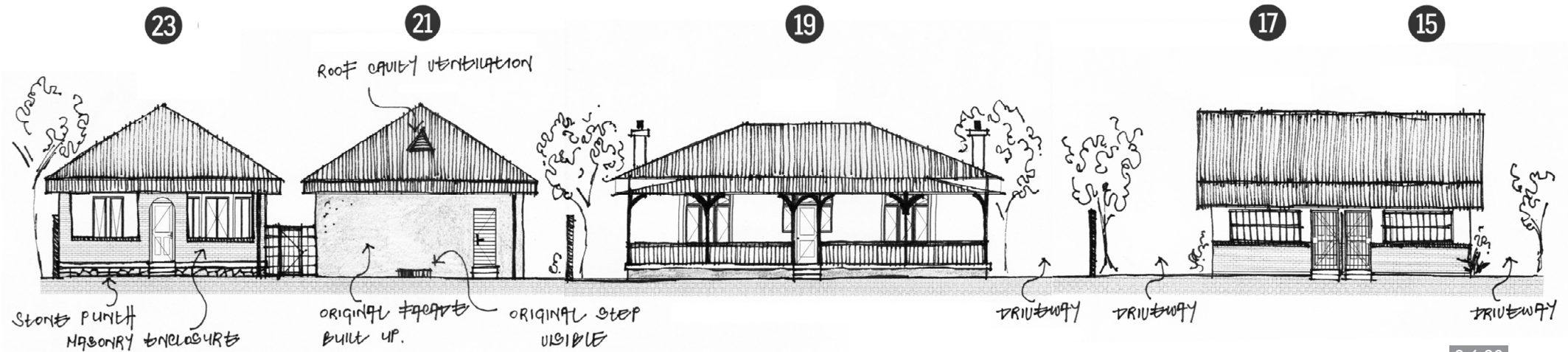
**Figure 2.1.19:** *21 Tulleken Street in 2009 (Google Earth 2017).*

## 2.1.5 GENERAL SITE ANALYSIS

### 2.1.5.1 MAPPING OF EXISTING FUNCTIONS

Through site visits, an understanding regarding the existing functionality of the site has been gained. The area is dense in residential users, with the combination of apartment blocks, private single-family houses and communes. Commercial functions have been established organically, as and when opportunities have arisen. For example, there is a tuckshop situated at 21 Tulleken Street, and the Malombo Lounge, at 24 Clara Street, is a jazz club that attracts many visitors over a weekend.

The area is dense, with large trees and a quiet residential atmosphere. The elevation of the street facing facades of 15, 17, 19, 21 and 23 Tulleken Street are hand drawn in Figure 2.1.20, and Figure 2.1.21 reflects the existing conditions on site, with the envisioned location of the main intervention circled on the site plan.



2.1.20

Figure 2.1.20: Elevation of Tulleken Street (Author 2017)

Figure 2.1.21: Site plan labelling the existing functions (Author 2017)



### 2.1.5.2 COMMUNITY ANALYSIS

Through informal discussions (refer to Appendix A) with the residents of the houses, insight has been gained into the community dynamic. For example, tenants, rather than the owners, reside in most of the houses in Tulleken Street (see Figure 2.1.22). Eleven, 15, 17 and 19 Tulleken Street belong to one owner who inherited the houses and lives outside of the city, while 21 and 23 Tulleken Street belong to an owner who has converted the two houses into communes to accommodate up to seven tenants per house.

The area is home to a few older white residents who have lived in their homes for up to 50 years, as well as younger black tenants who have moved in more recently (see Figures 2.1.23 to 2.1.25). A strong foreign component also exists, with residents from Zimbabwe and the Congo in the area. Thus, the area now is far more diverse than its original predominantly white rail worker inhabitant days.

Through investigating the activity and movement, it was found that an activity node exists around the tuckshop in front of 21 Tulleken Street. Most of the tuckshop's clients come from the apartment blocks across the street (see Figure 2.1.26).

During the week, the area becomes busy from 05:30 onwards, with residents leaving for work and returning in the evenings between 16:30 and 18:00. Most people make their way on foot to the

Gautrain station, the Pretoria Train Station, taxi's or busses close by.

Amidst the diversity in culture and age, a strong sense of community exists between the residents of the area. This is particularly noticeable in the familiarity between people passing each other on the street. This study aims to maintain this sense of community while also developing a tourist precinct.



- Tenants living in house
- Owners living in house

**Figure 2.1.22:** Mapping of tenants/ owners residing in the houses (Author 2017).



- Residents for the past:
- 0 - 10 years
  - 10 - 20 years
  - 20 - 30 years
  - 30 + years

**Figure 2.1.23:** Mapping of amount of years that the residents have been living in specific houses (Author 2017).





- Age of Residents:
- 20 - 40 years
  - 40 - 50 years
  - 50 - 60 years
  - 60 - 70 years
  - 70 + years

Figure 2.1.24: Mapping of the ages of residents (Author 2017)



- Race of Residents:
- White - Afrikaans Speaking - South African
  - White - English Speaking - South African
  - Black - English/ Other language - South African
  - Black - English/ Other language - Foreign National

Figure 2.1.25: Mapping of the race of residents (Author 2017)



- Other activities:
- Tuck Shop
  - Informal Trader
  - Jazz Cafe
  - Church

Figure 2.1.26: Mapping of activities in the area (Author 2017)

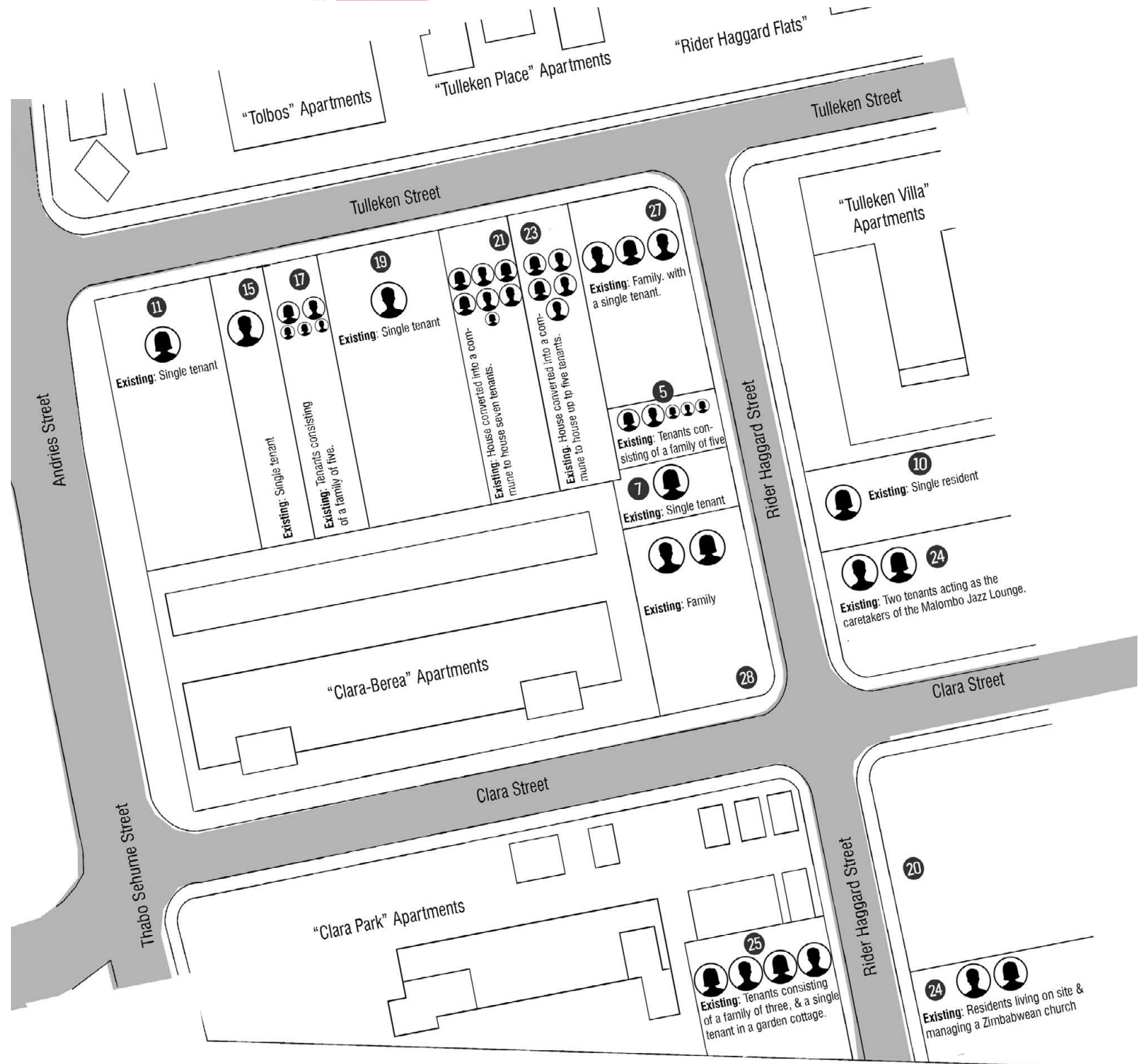
### 2.1.5.3 EXISTING SOCIAL CONDITIONS

Data gathered during site visits (refer to Appendix A for the informal discussion structure) indicate that many of the historic houses in Tulleken and Rider Haggard Streets are occupied with longstanding tenants, living on their own. This contrasts to the density of the adjacent apartment blocks.

As confirmed by some of the residents, an enduring familiarity and even friendship exists between the occupants of 11, 15 and 19 Tulleken Street, and 7, 10 and 25 Rider Haggard Street. This could be a result of the similarity in profile between these residents (refer back to Figures 2.1.22 to 2.1.26). Similarly, the occupants of 21, 23 and 27 Tulleken Street, as well as 5 and 24 Rider Haggard Street, and 24 and 26 Clara Street share stronger ties due to their African backgrounds, and have more of an affiliation with the apartment dwellers.

The cultural divide does not prevent the familiarity and neighbourly atmosphere that is present in the area, an aspect that will be advanced through the creation of an inclusive tourist precinct that promotes the interaction between locals, and locals and visitors. With the apartment blocks and houses directly facing the street, a visitor experiences the feeling of not being isolated, which contributes positively to the safety and vigilance of the community.

2.1.27



2.1.5.4 CLIMATE STUDY

Solar Study

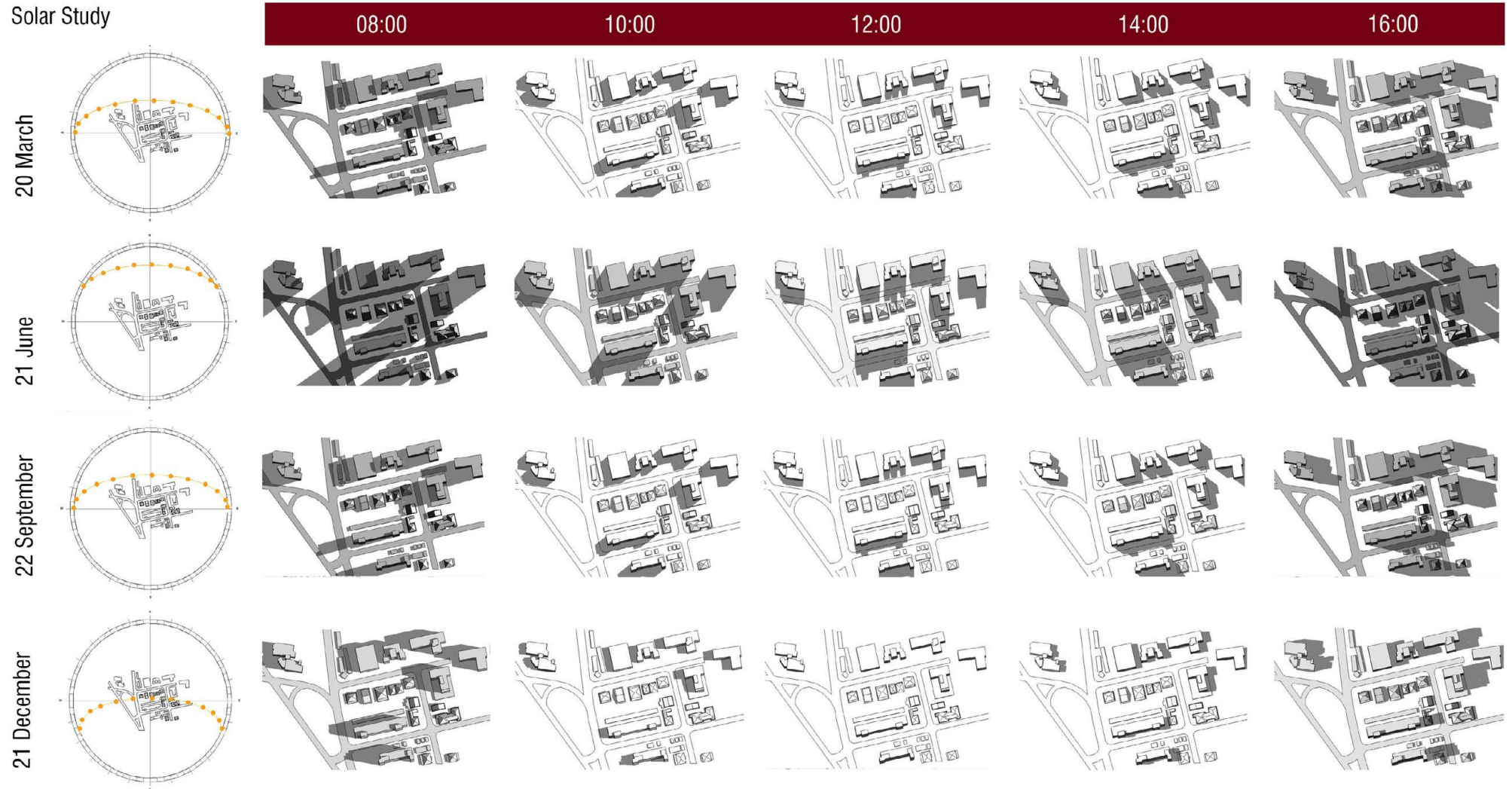


Figure 2.1.27: Layout of existing social conditions in the area (Author 2017).

Figure 2.1.28: Solar study generated through Revit 2017 (Author 2017).

2.1.28

#### 2.1.5.4 CLIMATE STUDY

The solar study of the block (see Figure 2.1.28) indicates that the high-rise apartment blocks cast shadows over some of the single-storey houses in the mornings and afternoons in winter. This has also been confirmed by a resident living in Rider Haggard Street.

Most of the residents interviewed also noted that their homes are very cold during winters, which could be a combined result of the dense trees in the area blocking out the sun and the small windows that many of the historic houses have.

All the houses in Tulleken Street are well orientated, facing north. The houses in Rider Haggard face east or west, resulting in less favourable conditions with harsh morning or afternoon sunlight.

As part of the proposed design intervention, some of the trees can be trimmed by a specialist to increase the amount of natural daylight reaching these single-storey houses. The trees form part of the cultural landscape and contribute to the character of the site, making specialised trimming the option preferred to removal. This is in line with the Green Star SA criteria regarding environmental sustainability.

**Figure 2.1.29:** A view of Tulleken street (Author 2017)

**Figure 2.1.30:** A view of Rider Haggard street (Author 2017)

**Figure 2.1.31:** Plan and section of the sidewalk (Author 2017)

#### 2.1.5.5 SIDEWALK ANALYSIS

During an analysis of the sidewalks (see Figures 2.1.29 to 2.1.31), it was found that the paved sidewalk has been damaged in numerous places. This damage has occurred largely due to the roots of trees planted in the adjacent soil bed lifting the blocks. The sidewalk requires an upgrade to ensure that it has an even surface throughout and that it becomes more accessible to disabled users. This is particularly important for the proposed tourist precinct, as more people will be using this sidewalk due to the pedestrian nature of the precinct.

Trees can be found every 10-15m (age unknown), hinting at possible formal landscaping done in the past.

2.1.29



#### 2.1.5.6 MOVEMENT AND ACTIVITY

The plan in Figure 2.1.32 analyses the movement and activity around the site. Tulleken and Rider Haggard Streets are mainly used by the residents leaving home and coming back from work. Both streets experience a lot of foot traffic. These streets also both end in a cul-de-sac. Clara Street becomes a thoroughfare between Thabo Sehume Street, with single directional lanes heading south, and Lilian Ngoyi Street, heading north. Parking on the road in Tulleken, Rider Haggard and/or Clara Streets is not permitted, with 'no parking' signs placed at regular intervals. There are, however, a few cars that park on the street for a short period of time during the day. Not many of the residents in the houses and apartment blocks seem to have or use private cars, but rather make use of the many public transport options close by. The width of the two-lane streets, including the yellow line markers, are around 7m.

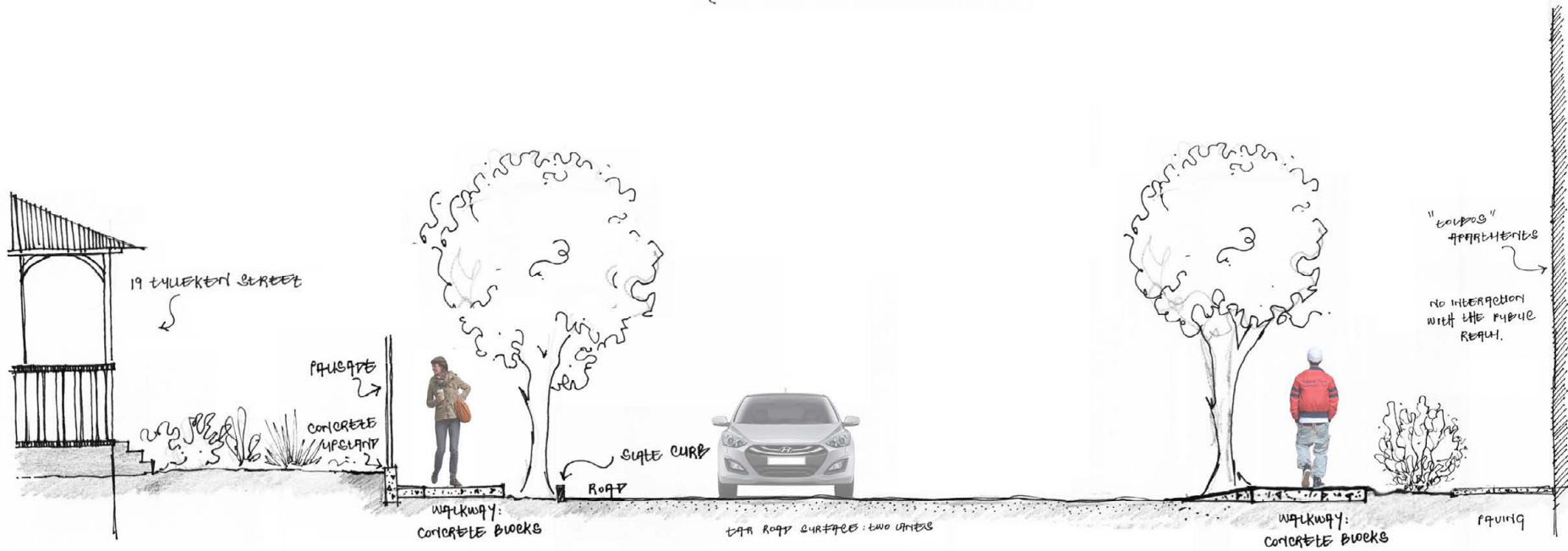
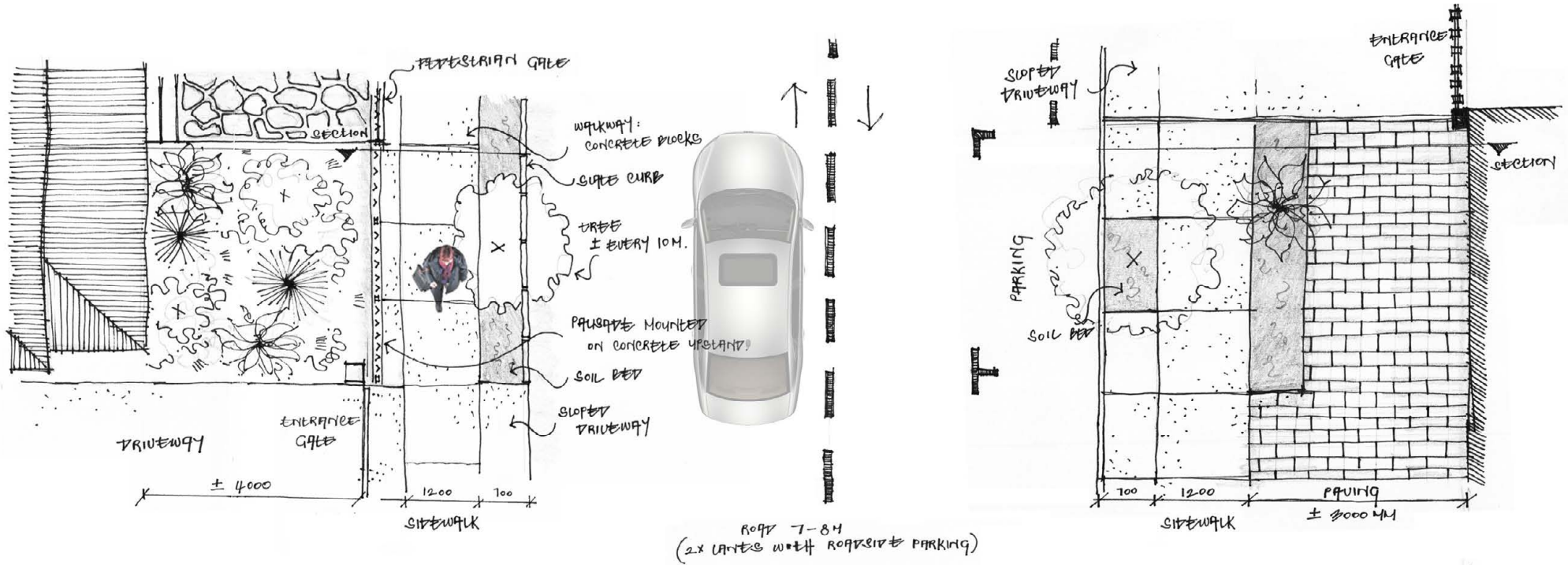
2.1.30



#### 2.1.5.7 BOUNDARIES AND ACCESS

An investigation into the boundaries on site indicates that security is an important aspect for all the residents. All the houses in Tulleken Street are surrounded by palisade fences, with additional barbed wire on top. Brick walls or prefab concrete walls are more common in Rider Haggard Street, except for Number 25, whose only boundary is a low vegetation hedge (see Figure 2.1.33).

A sidewalk of around 2.2m wide separates the boundaries of the properties from the street in Tulleken and Rider Haggard, and each house is set back from the paved sidewalk by between 2000 to 5000mm. Central pedestrian gates can usually be found leading to the centrally located entrances of the houses.



2.1.31

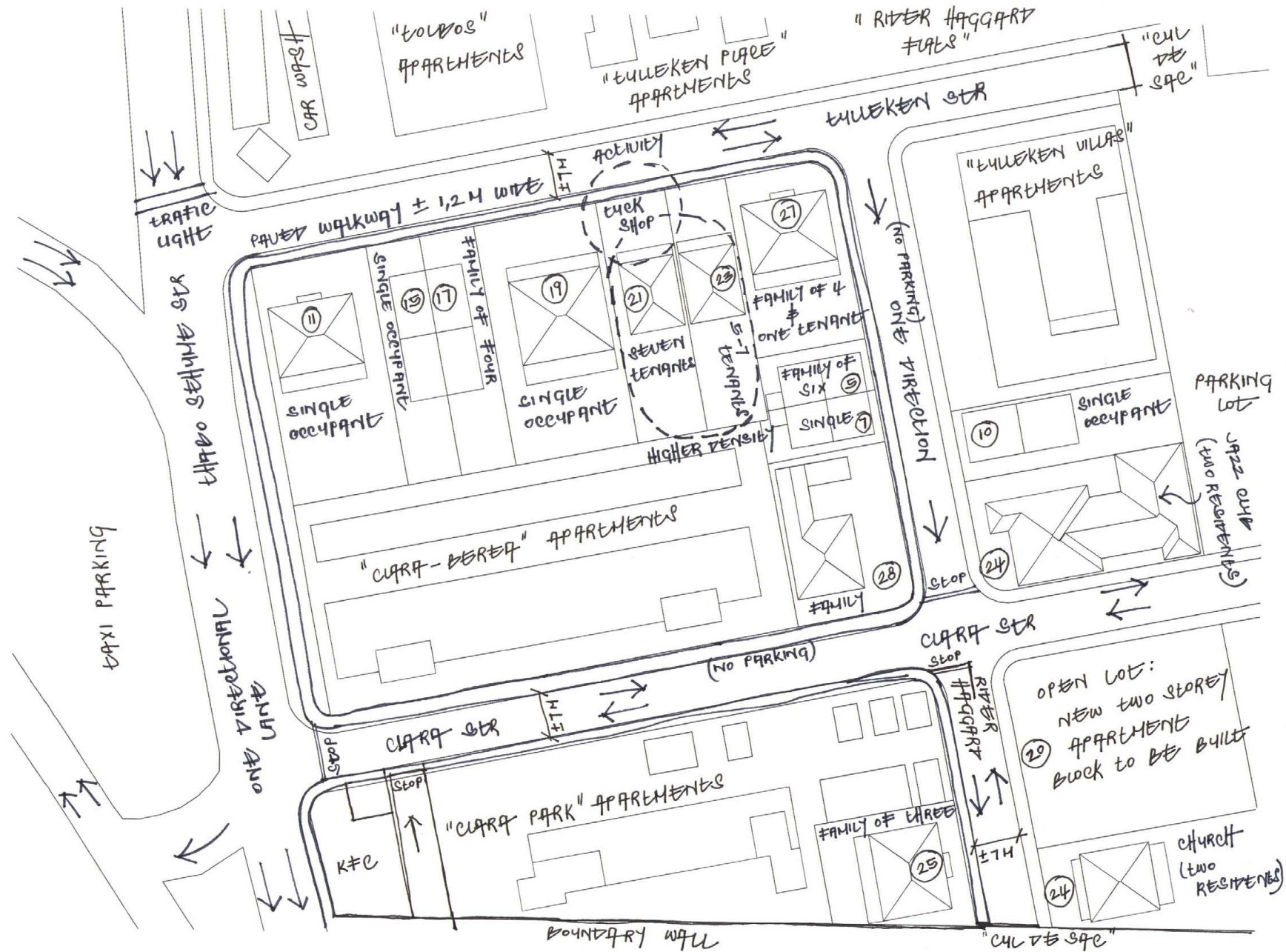


Figure 2.1.32: Map of movement and activity (Author 2017)

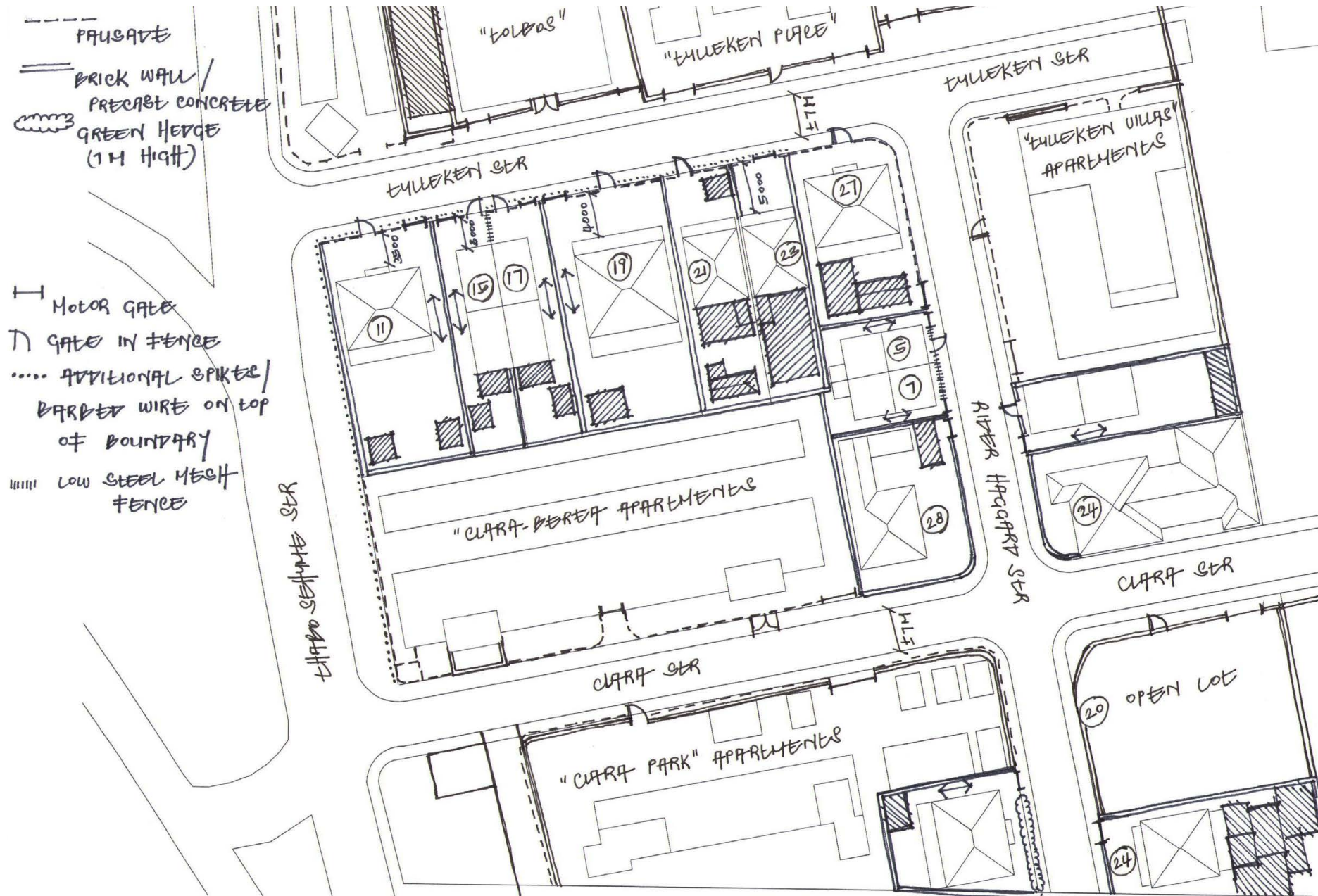


Figure 2.1.33: Map of boundaries (Author 2017)

2.1.6 DOCUMENTATION AND ANALYSIS: 15 AND 17 TULLEKEN STREET



Figure 2.1.34: Tulleken Street elevation (Author 2017)

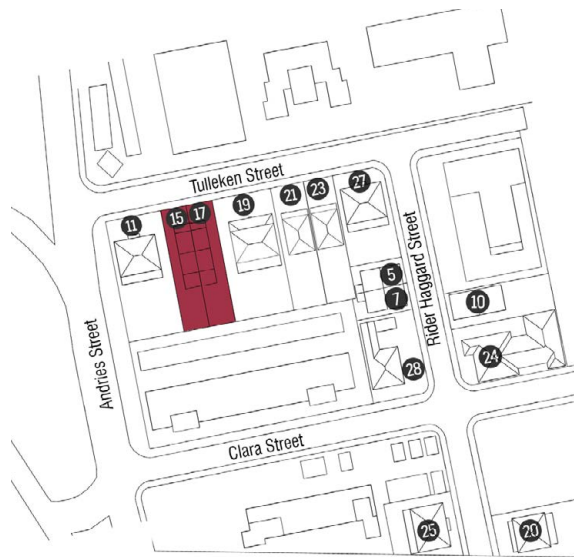


Figure 2.1.35: 15 and 17 Tulleken Street indicated on the site keyplan (Author 2017)

1990



Figure 2.1.36: 15 and 17 Tulleken Street in 1990 (Le Roux 1990:160)

2009



Figure 2.1.37: 15 and 17 Tulleken Street in 2009 (Google Earth 2017)

2017



Figure 2.1.38: 15 and 17 Tulleken Street in 2017 (Author 2017)





2.1.39



2.1.40



2.1.41



2.1.42

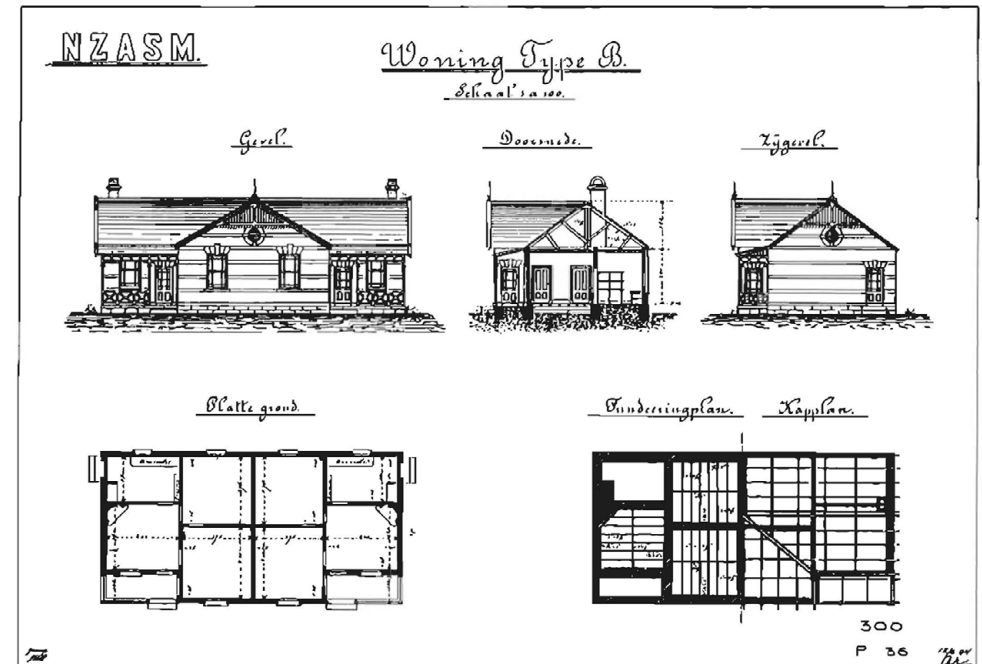
Figure 2.1.39: An arched doorway between the passage to the dining room (Author 2017)

Figure 2.1.40: A pressed metal ceiling in the main bedroom (Author 2017)

Figure 2.1.41: The masonry fireplace in the dining room (Author 2017)

Figure 2.1.42: The transition between the vinyl tiles in the kitchen to the vinyl tiles on the enclosed back porch (Author 2017)

## COMPARISON WITH NZASM HOUSING TYPE B



2.1.43

When comparing 15 Tulleken Street to NZASM Housing Type B, the following similarities can be found:

- The houses consist of a semi-detached cottage;
- The floor layouts, with relation to the size and placement of the rooms are the same;
- The houses are lifted on a plinth, and the edges of the slabs are visible;
- There are two fireplaces, one per house; and
- The pitched roofs consist of corrugated iron sheeting.

Figure 2.1.43: Plan and elevation of Type B semi-detached cottage, NZASM drawing dated 12 June 1894 (de Jong 1990:56)

The main heritage features of 15 Tulleken Street are:

- Pressed copper ceilings in the bedrooms, passage, dining room and kitchen;
- Solid wooden plank flooring in the bedrooms, passage and dining room;
- A corner masonry fireplace; and
- A decorative plaster ventilation brick in the kitchen.

Some interior finishes appear to date from an alteration around 1960, for example the vinyl tiles in the kitchen. Figures 2.1.34 to 2.1.43 present a visual breakdown of the aforementioned areas of comparison.

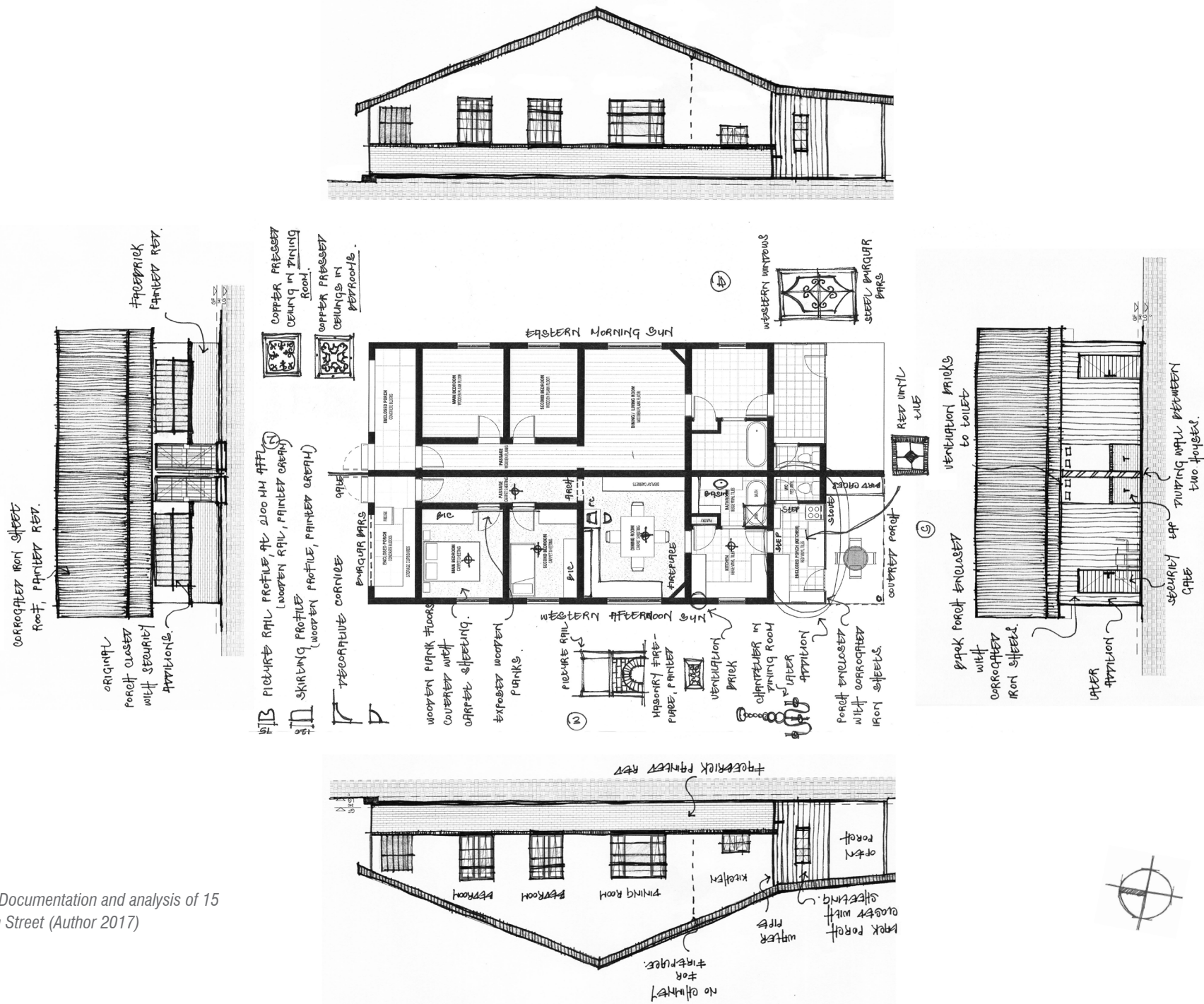
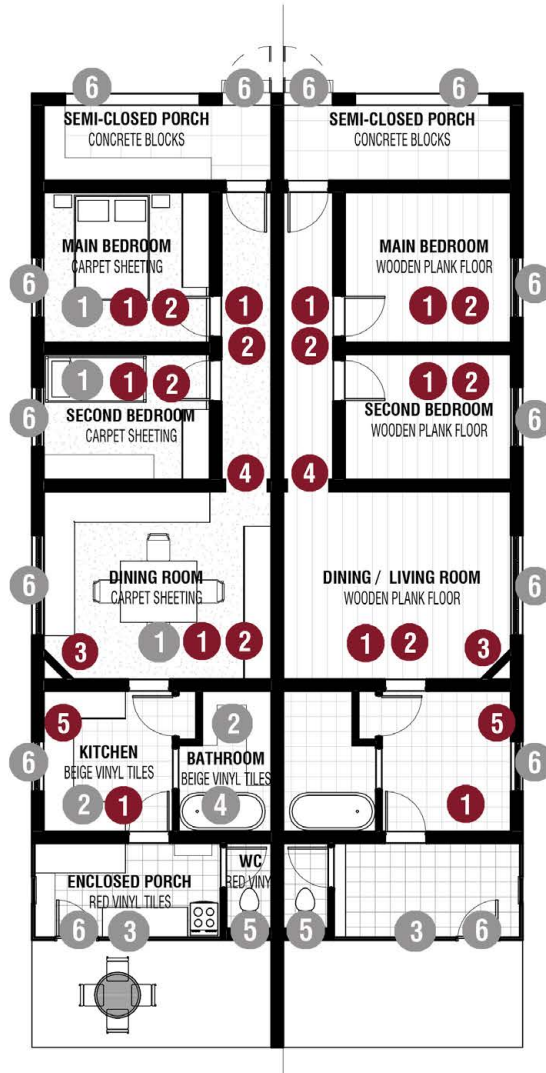


Figure 2.1.44: Documentation and analysis of 15 and 17 Tulleken Street (Author 2017)

- Previously altered fabric  
Proposed action: To be reinterpreted, stripped back and altered as necessary
- Precious heritage fabric  
Proposed action: Add-ons stripped back, original fabric restored and preserved.



- 1 Wooden plank floors had been painted and covered with carpet sheeting.
- 2 Original floor finish had been replaced with a vinyl tile.
- 3 The open back porch had been enclosed with corrugated iron sheeting.
- 4 The bath had been converted to include a shower.
- 5 The toilet had been added at a later stage.
- 6 Security additions had been made, for example burglar bars on the windows and security gates.
- 1 Original pressed copper ceiling at approximately 3000mm AFFL.
- 2 Original solid wooden plank flooring.
- 3 Original masonry fireplace. Paint addition to be stripped.
- 4 Arched doorway found in almost all the structures.
- 5 Original plaster ventilation brick built-in.
- 6 Most rooms fitted with a decorative cornice, picture rail and skirting.

Figure 2.1.45: Mapping of precious heritage fabric and previously altered fabric (Author 2017)

## 2.1.7 DOCUMENTATION AND ANALYSIS: 19 TULLEKEN STREET



Figure 2.1.46: Tulleken Street elevation (Author 2017)



Figure 2.1.47: 19 Tulleken Street indicated on the site keyplan (Author 2017)

1990



Figure 2.1.48: 19 Tulleken Street in 1990 (Le Roux 1990:160)

2009

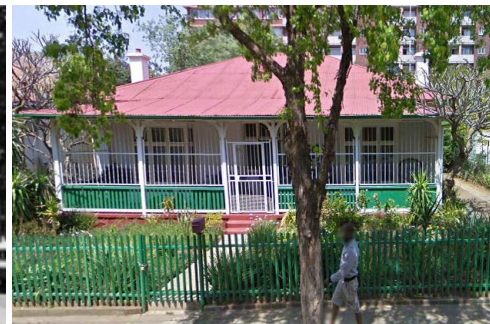


Figure 2.1.49: 19 Tulleken Street in 2009 (Google Earth 2017)

2017



Figure 2.1.50: 19 Tulleken Street in 2017 (Author 2017)



2.1.51



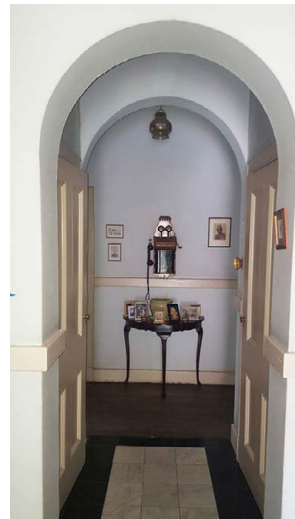
2.1.52



2.1.53



2.1.54



2.1.55

Figure 2.1.51: Wooden fireplace in the dining room (Author 2017)

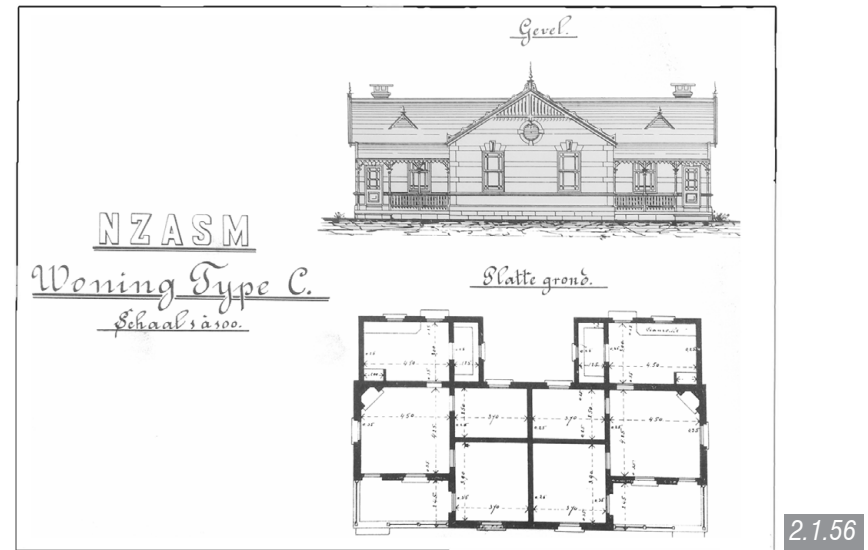
Figure 2.1.52: Pendant in the entrance foyer (Author 2017)

Figure 2.1.53: A brass lightswitch (Author 2017)

Figure 2.1.54: The street-facing veranda (Author 2017)

Figure 2.1.55: View of the passage from the entrance foyer (Author 2017)

## COMPARISON WITH NZASM HOUSING TYPE C



2.1.56

When comparing 19 Tulleken Street to NZASM Housing Type C, the following similarities can be found:

- The floor layout is similar for both houses with relation to the size and placement of the rooms;
- The veranda balustrade and wooden columns supporting the sloping roof are also similar in both cases;
- Both houses are lifted on a plinth, and the edge of the slab is visible;
- There are two fireplaces at opposite ends of the houses; and
- The pitched roof consists of corrugated iron sheeting.

The main heritage features of 19 Tulleken Street are:

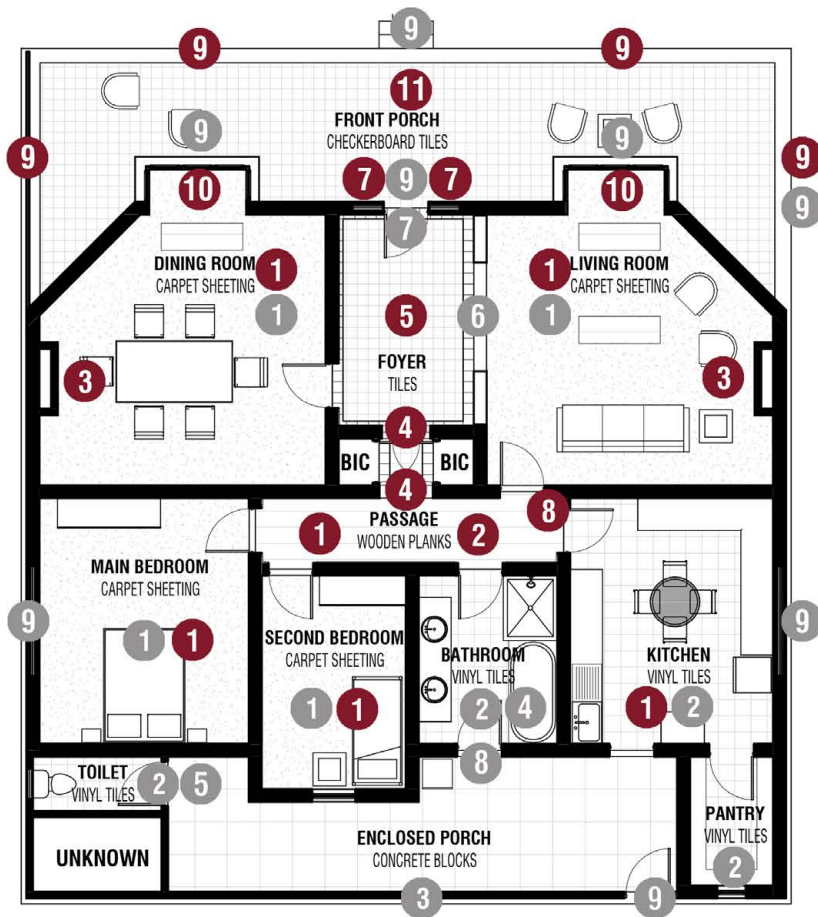
- The ornate veranda with decorative wooden columns and balustrade;
- Stained glass windows on the front door and interior bathroom door;
- Two wooden fireplaces with wooden inlays – metal and tile decoration;
- Solid wooden plank flooring in the passage;
- Tiles in the entrance lobby with the appearance of marble; and
- Original brass light switches (no longer functional).

Figure 2.1.56: Plan and elevation of Type C semi-detached cottage, NZASM drawing (de Jong 1988)

Some interior finishes appear to date from an alteration around 1960. For example, the vinyl tiles in the kitchen, bathroom and toilet, and the coloured sanitary fittings. Figures 2.1.7.1 to 2.1.7.13 provide visual representations of this comparison.



- Previously altered fabric  
Proposed action: To be reinterpreted, stripped back and altered as necessary
- Precious heritage fabric  
Proposed action: Add-ons stripped back, original fabric restored and preserved.



- 1 Wooden plank floors had been painted and covered with carpet sheeting.
- 2 Original floor finish had been replaced with a vinyl tile.
- 3 The open back porch had been enclosed with corrugated iron sheeting.
- 4 The bathroom had been altered to include a shower, bath and double basin.
- 5 The toilet had been added at a later stage.
- 6 An opening was created and finished with facebrick.
- 7 The original front door was replaced with a solid wooden door after a burglary
- 8 The pattern of the stained glass in the door appears to be a later addition.
- 9 Security additions had been made, for example burglar bars on the windows and security gates.
- 1 High ceiling at approximately 3000mm AFFL.
- 2 Original solid wooden plank flooring.
- 3 Original wooden fireplace with wooden inlays, metal and tile decoration
- 4 Arched doorway found in almost all the structures.
- 5 Original marble tiles.
- 6 Most rooms fitted with a decorative wooden cornice, picture rail, dado rail and skirting.
- 7 Original stained glass in wooden frame windows.
- 8 Original brass lightswitch (no longer functional).
- 9 An ornate veranda with decorative wooden columns and balustrade.
- 10 Original wooden bay windows with decorative trimmings.
- 11 Porcelain checkerboard floor tiles.



Figure 2.1.58: Mapping of precious heritage fabric and previously altered fabric (Author 2017)

## 2.1.8 DOCUMENTATION AND ANALYSIS: 21 AND 23 TULLEKEN STREET



Figure 2.1.59: Tulleken Street elevation (Author 2017)

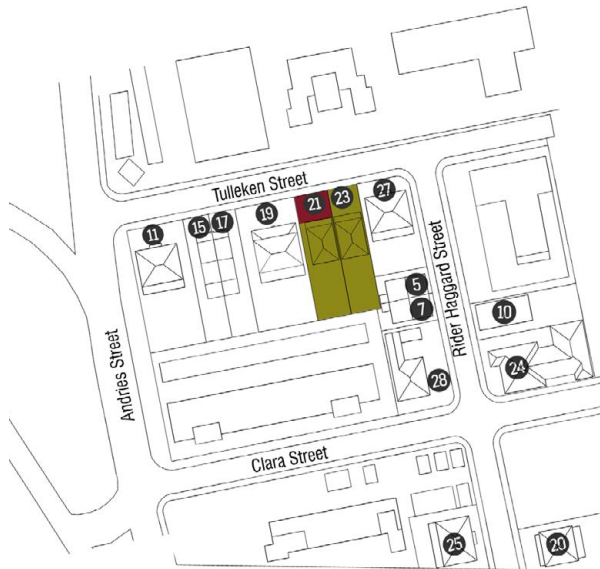


Figure 2.1.60: 21 and 23 Tulleken Street indicated on the site keyplan (Author 2017)



Figure 2.1.61: 21 Tulleken Street in 1990 (le Roux 1990:160)



Figure 2.1.62: 21 Tulleken Street in 2009 (Google Earth 2017)



Figure 2.1.63: 21 Tulleken Street in 2017 (Author 2017)



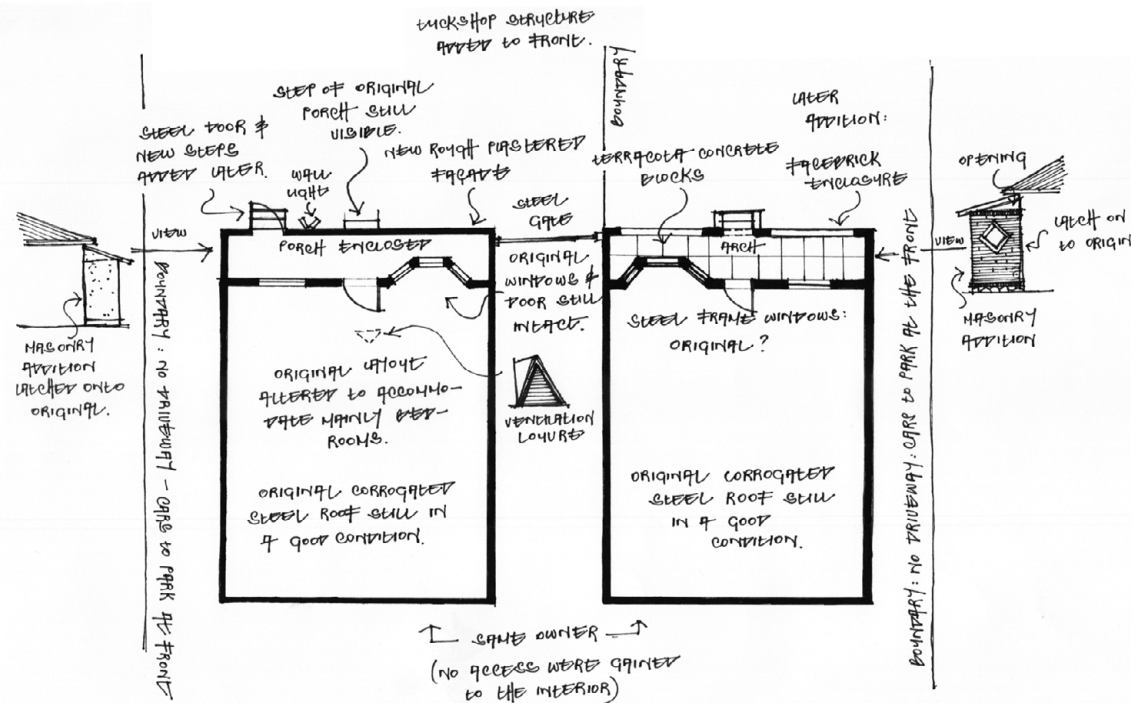
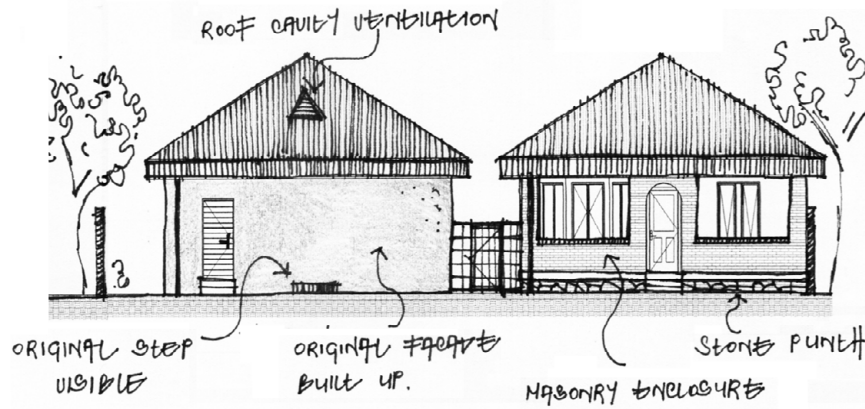
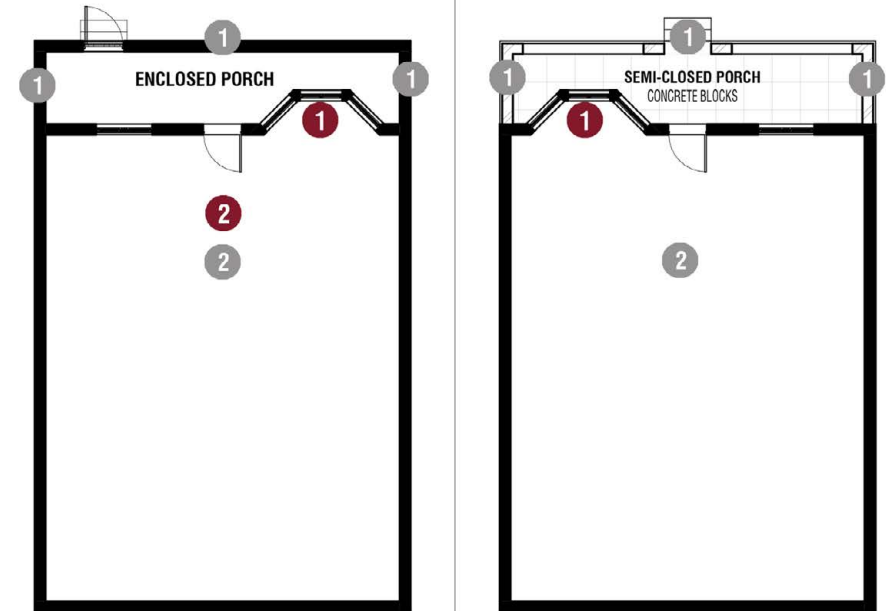


Figure 2.1.64: Documentation and analysis of 21 and 23 Tulleken Street (Author 2017)

- Previously altered fabric  
Proposed action: To be reinterpreted, stripped back and altered as necessary
- Precious heritage fabric  
Proposed action: Add-ons stripped back, original fabric restored and preserved.



- 1 The open front porch had been enclosed with a masonry leaf.
- 2 Original layout had been altered to accommodate more bedrooms.
- 1 Original bay window.
- 2 Corrugated steel roof with triangular roof cavity ventilation louvre.

Figure 2.1.65: Mapping of precious heritage fabric and previously altered fabric (Author 2017)

## 2.1.9 STATEMENT OF SIGNIFICANCE

The Burra Charter (ICOMOS 2013), an Australian charter that provides standards on conserving and managing places of cultural significance, states that cultural significance is determined by **aesthetic, historic, social or spiritual value for past, present and future generations**. The value is “embodied in the place itself, its fabric, setting, use, associations, meanings, records, related places and related objects” (ICOMOS 2013:2).

The proposed study site can be analysed according to this Charter’s standards:

- The houses possess an **aesthetic** that is characteristic of the early houses built in Pretoria, with European influences from NZASM’s housing typologies. This typology can be observed around the Pretoria Train Station, as well as in numerous other railway developments across the country, for example in Heidelberg and Volksrust (see Figure 2.1.7).
- The structures are **older than 60 years** and thus protected by the National Heritage Resources Act (Nr 25 of 1999). They hold historic value as a representation of Pretoria’s early plot layout and the residential development of a century ago. Heritage features are found in the built fabric, such as in the pressed metal ceilings, decorative ventilation

bricks and ornate built-in fireplaces. **These features are significant and should be preserved because they are true to the era from which they date, original to the structure and possess a certain rarity.** In places where extreme alterations and degradation have subtracted from the heritage value, the additional fabric should be stripped back and the original restored.

- The houses are **scientifically informative with regard to early 20th century building methods and materials**. Such materials include solid wood plank suspended floors; wooden cornices, skirtings, dado rails and picture rails; double brick interior walls; 3m high-pressed metal ceilings; natural stone tiles; originally no interior provision made for toilets; and no electrical wiring in the walls.
- **Social and spiritual significance lie in the community on site, who have displayed resilience in the face of a drastic change in the urban context.** Residents who have lived on site for up to 50 years are witness to the changing city and play a meaningful role in the cultural significance of the site, particularly in terms of the experience and knowledge they can contribute. The social value on site also lies in the peaceful **co-habitation**

that exists between the residents, who are diverse in age, culture and place of origin.

**The heritage approach to the structures on site will not be uniform throughout, but rather determined by each house’s condition and cultural significance.**

A combination of the following approaches is undertaken:

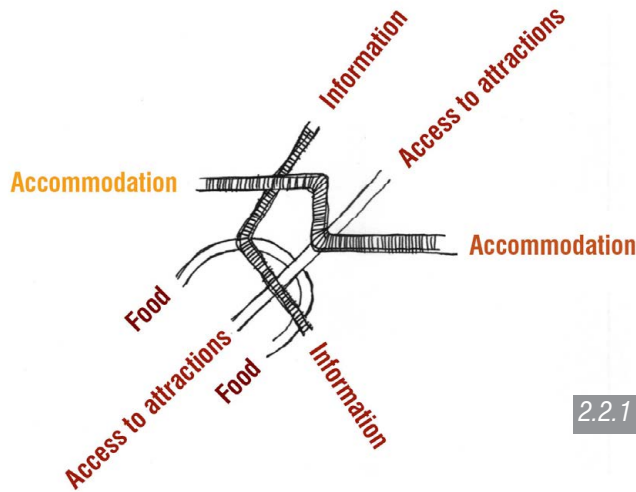
- The process of conservation, which implies caring for a place to ensure that its cultural significance, is maintained;
- The process of maintenance, meaning the continuous protective care of a place and its setting, is undertaken;
- The process of adaptation, such as changing the place to suit the existing use or a proposed use, is incorporated;
- The process of preservation, which means maintaining a place in its existing state and retarding deterioration, is adhered to; and
- The process of restoration, through returning a place to a known earlier state by removing accretions or by reassembling existing elements without the introduction of new material, is employed (ICOMOS 2013:2).

**Design guidelines that can be derived from the Statement of Significance are:**

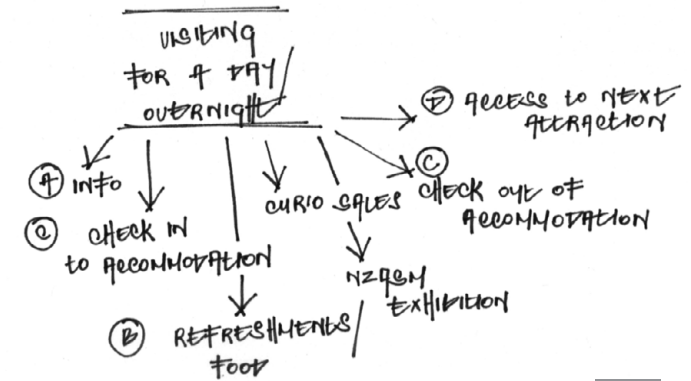
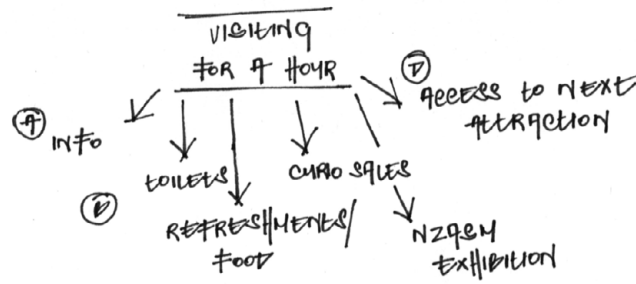
- The aesthetic and heritage features of the site should be conserved and maintained;
- Built fabric that does not contribute to the heritage value of the structure should be stripped away, where necessary, to expose and celebrate heritage features; and
- The structures are informative regarding Pretoria’s historical context and can play a role in the public realm of educating users.



# PART 2: PROGRAMME



2.2.1



2.2.2

## 2.2.1 TOURISM AS CATALYST

An approach to maintaining the cultural and historical value of the area is to introduce a new function which can attract diverse visitors in a bid to regenerate the area. As a catalyst to generate interest, tourism interventions are proposed in and around selected houses, with the intention of stitching the fragmented urban fabric from the interior outwards. The choice of tourism as a catalyst is informed by the site's prime location in relation to tourist attractions and public transport. This choice is further informed by the tourism

opportunities set out in the City of Tshwane 2055 Vision and the Tshwane Inner City Regeneration Programme (2015). The urban vision for the site is to create the NZASM tourist precinct, with different amenities and accommodation options for tourists. Diagram 2.2.1 represents the basic requirements of a tourist, which include access to information, accommodation, refreshments and food, and attractions. The outcome of the precinct is to meet the requirements of a tourist whether they are only visiting the site for an hour or a few days (see Diagram 2.2.2).

**Diagram 2.2.1:** The functional requirements of a tourist precinct (Author 2017)

**Diagram 2.2.2:** The requirements of a tourist visiting for an hour and a day (Author 2017)

## 2.2.2 CRITIQUE OF THE TSHWANE TOURIST INFORMATION OFFICE

The Tshwane Tourist Information Office, located in the Old Nederlandsche Bank in Church Square was analysed. The information office is currently the closest source of information for tourists arriving at the proposed site, consisting of a 1.8km/ 20min walk to Church Square (see Figure 2.2.5).

- **Business hours:** Monday - Friday 08:00 - 17:00, Closed Saturday - Sunday
- **Services offered:** Information, arranging tours through tour companies and partnering with other cities.
- **Info aids:** Brochure stands, 4 x cubicles for consultants. Plasma screens to be installed in July 2017.
- **Clients:** Mainly international visitors: families and couples.

- **Date of establishment:** 2000
- **Aim:** To grow and digitize the function, and assist more local tourists.
- **Managed by:** The Tshwane Tourism Association
- **Other information offices:** Wonderboom Airport

Figure 2.2.1: Exterior Western elevation of Old Nederlandsche Bank (AbleWiki 2010)

Figure 2.2.2: Exterior directional signage (AbleWiki 2010)

Figure 2.2.3: Photos and analysis of the existing tourist information office (Author 2017)



2.2.1



2.2.2

NATURAL DAYLIGHT + ARTIFICIAL LIGHTING = INSUFFICIENT.

EXISTING INTERIOR LEFT UNALTERED:  
NO CHANGES TO ACCOMMODATE NEW FUNCTION.

CONSULTANTS SITTING IN CLUSTED CUBICLES - LITTLE INTERACTION WITH PUBLIC ENTERING THE SPACE.

MAKERIQUELY OF NEW FUNCTION = UNINSPIRING, DOESN'T RELATE TO THE EXPERIENCE OF TOURISM.

NO CLEAR START & END TO EXPERIENCE: POOR BEDQUILITY, POOR LAYOUT.

2.2.3



### 2.2.3 SITE AMENITIES

Mapping the amenities relevant to tourists indicates that all requirements can be met within a five-minute walk from site (see Figure 2.2.4). The area is rich in restaurants and fast food cafes, with many public transport options in the vicinity.

### 2.2.4 TOURIST ATTRACTIONS

A study of the area indicated that tourists can easily visit attractions from the site as a starting point by taking a brief walk or making use of public transport. The Gautrain bus runs every day of the week from the train station, up to the Pretoria Zoo in the North, with easy access to Church Square and the Kruger House Museum (see Figure 2.2.5). Uber is recommended for the 10-minute drive to Freedom Park.

Melrose House, Burgers Park, the Ditsong Natural History Museum, the Ditsong Cultural History Museum and City Hall are also all reachable within a five- to 10-minute walk from the site in a northerly direction. Additionally, the Gautrain can be used to travel to the rest of Pretoria and Johannesburg, including the airport.

The route between the Gautrain station and the site is easy to undertake for a pedestrian, consisting of a 250m/four-minute walk. Recommendations have been made to ensure a safe and legible journey (see Figures 2.2.6 to 2.2.7).



-  **Site Location**
-  **Restaurants**  
The Station Lounge  
Relevance for Men  
Pfamoni Flame Grill Cafe  
Malombo Jazz Cafe
-  **Fast food / Take-aways**  
KFC  
Mc Donalds  
Debonairs  
Chesa Nyama  
Chicken Licken  
Nandos
-  **Music Venues**  
Malombo Jazz Cafe  
Red Right Hand Venue
-  **Hotel Accommodation**  
Belgrave Hotel  
StayEasy Pretoria  
Kia-Ora Lodge  
Manhattan Hotel
-  **Petrol Station**  
Engen  
Caltex
-  **Coffee Shops**  
Pltfm Cafe
-  **Kiosks / Informal Vendors**  
Cafe 79 Kiosk
-  **ATM**  
Standard Bank  
ABSA Bank  
FNB
-  **Public Transport**  
Pretoria Train  
Gautrain  
Metered Taxi's  
Minibus Taxi's  
Busses: Intercape, Translux
-  **Shops**  
Pick a Pay  
Pep Stores  
Mr Price  
Saverite Supermarket
-  **Tourist Attractions**  
Melrose House  
Freedom Park  
Herbert Baker Station

2.2.4

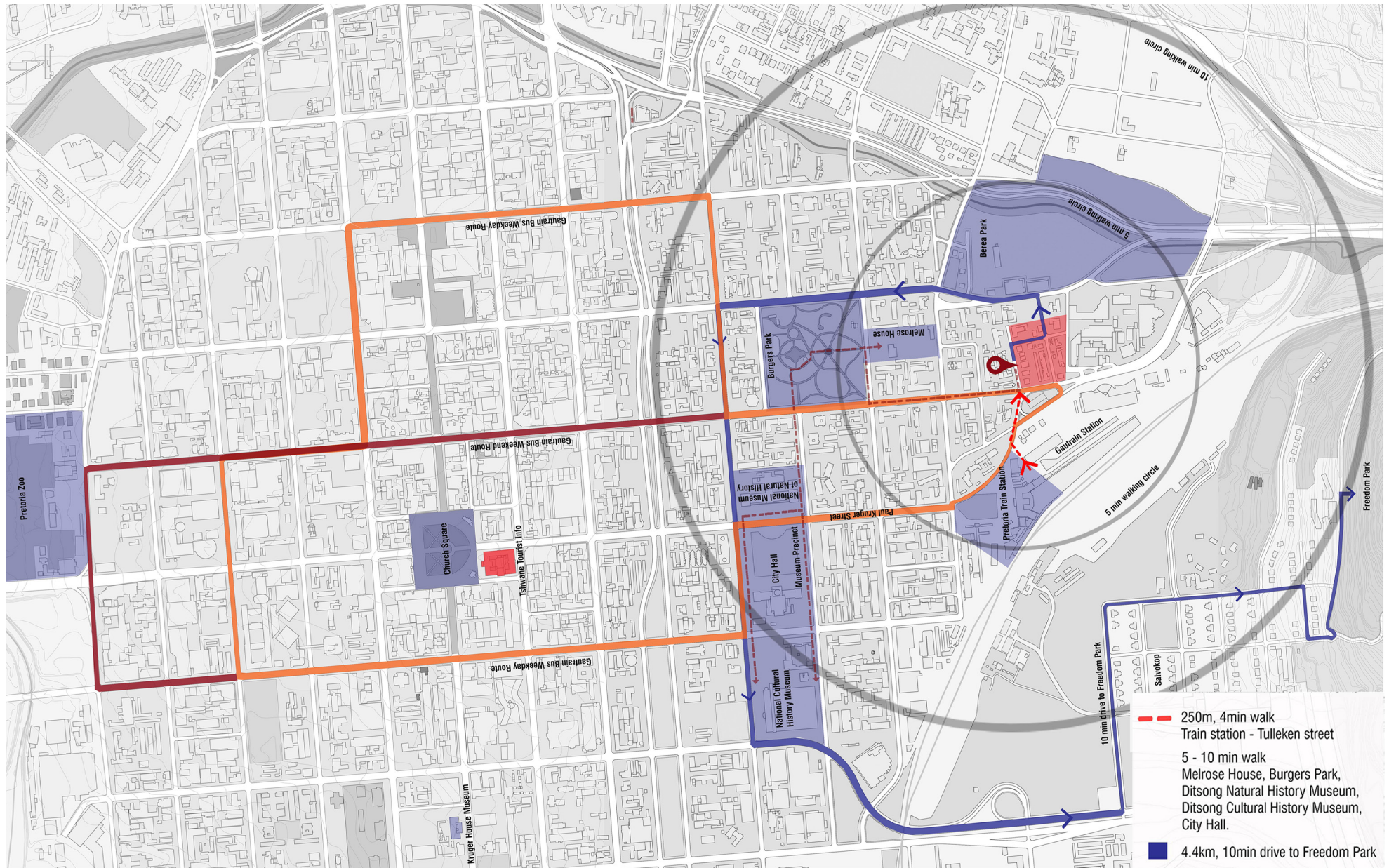


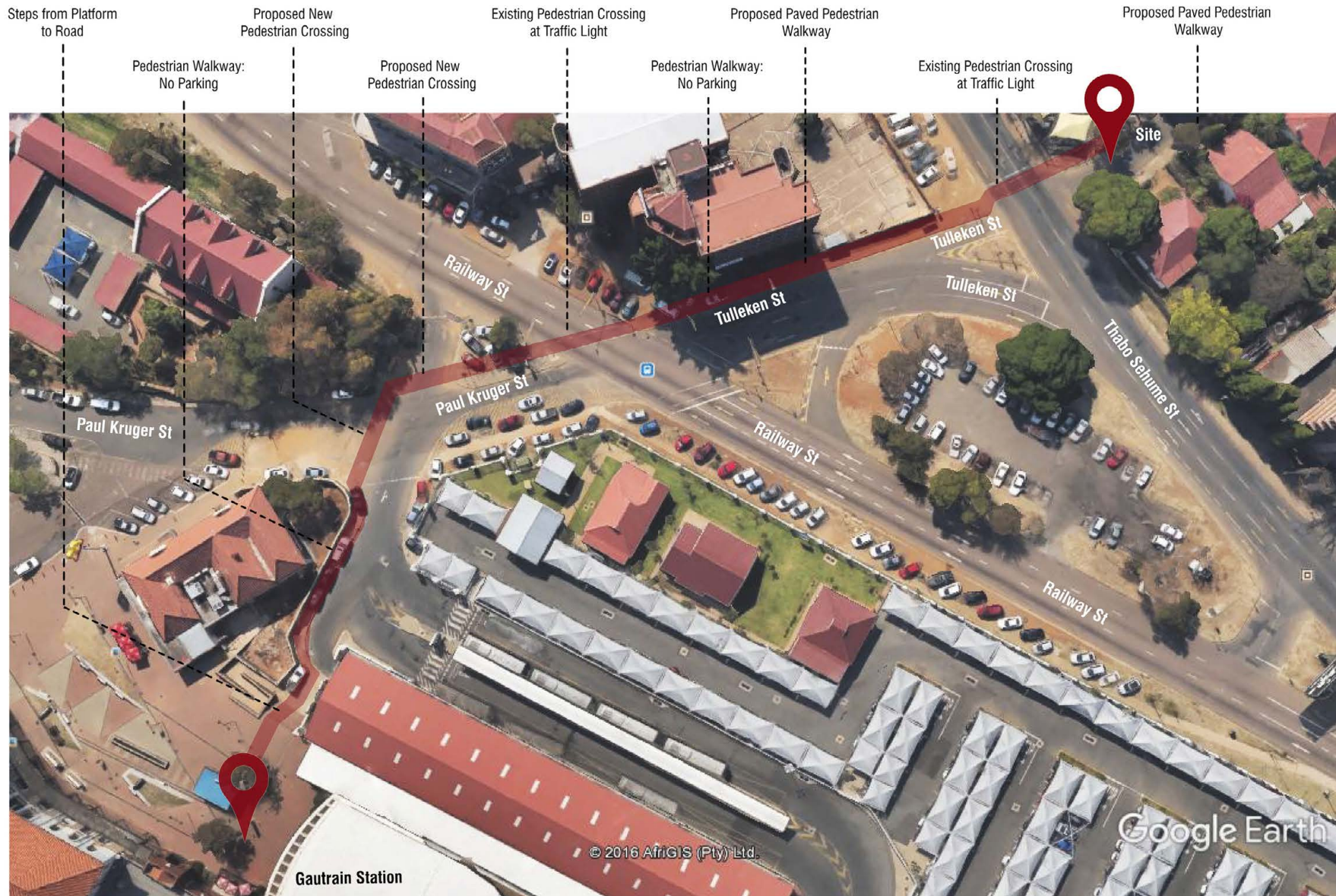
Figure 2.2.4: Site amenities relevant to tourists (Author 2017)

Figure 2.2.5: Tourist routes and activity (Author 2017)

2.2.5

- 250m, 4min walk  
Train station - Tulleken street
- 5 - 10 min walk  
Melrose House, Burgers Park,  
Ditsong Natural History Museum,  
Ditsong Cultural History Museum,  
City Hall.
- 4.4km, 10min drive to Freedom Park
- Gautrain Bus Route:  
P3 CBD: Mon -Fri:  
First Bus 06:12, Last Bus 21:12  
P5 Zoo: Sat -Sun:  
First Bus: 09:15, Last Bus: 18:15
- 1.8km, 8min drive, 20min walk  
to the Tshwane Tourist Info Office.

2.2.5 ROUTE FROM GAUTRAIN STATION TO SITE\_ 250m/ 4min walk

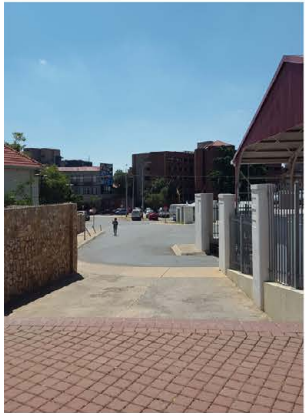
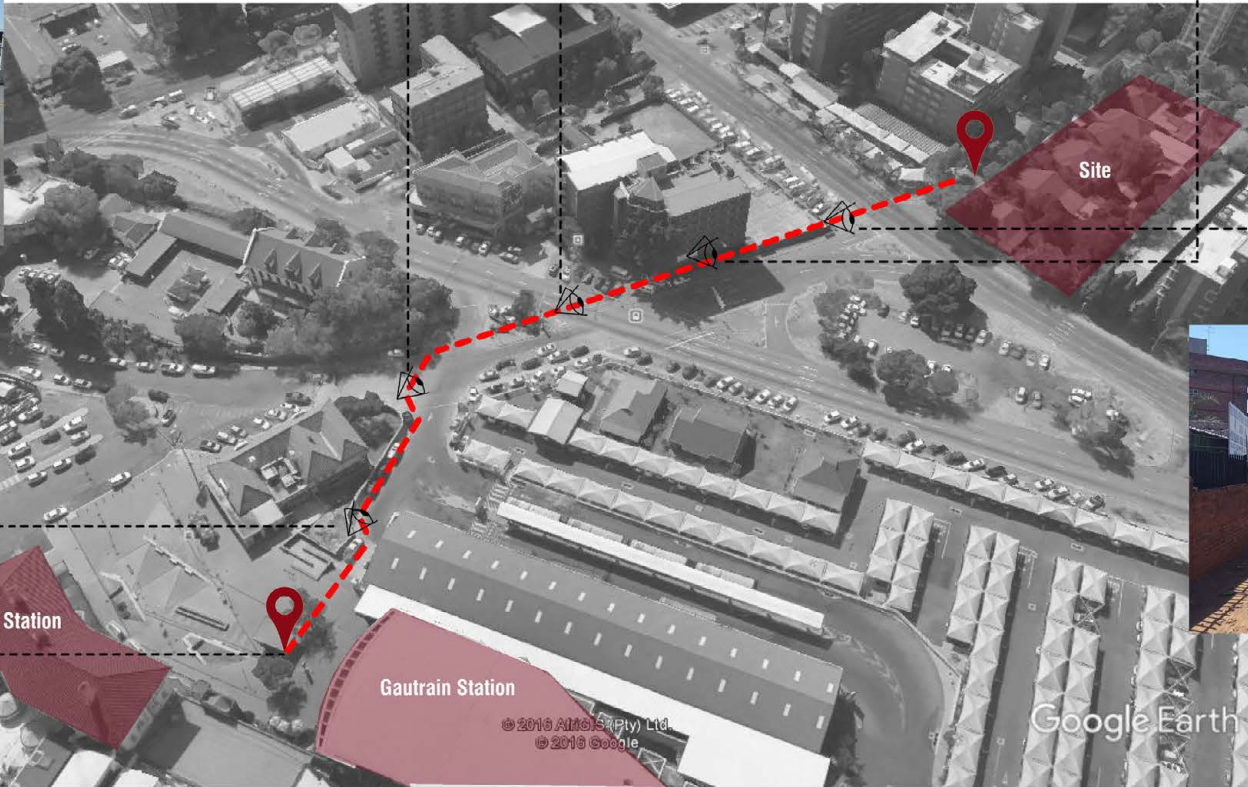


2.2.6

Google Earth







2.2.7

Google Earth

feet meters 100 400

Figure 2.2.6: Route from Gautrain to site (Author 2017)

Figure 2.2.7: Visual mapping of route (Author 2017)

## 2.2.6 PROGRAMMATIC LAYOUT OF THE NZASM TOURIST PRECINCT

For the creation of a fully functional tourist precinct the basic requirements of a tourist need to be addressed. These include access to information, accommodation, refreshments and food, and attractions. Figure 2.2.6.1 proposes the layout of a tourist precinct that could cater for all the needs of a tourist whether visiting the site for an hour or a few days. Information and access to attractions can be made available through the introduction of a tourist information centre, accommodation can be addressed with a youth hostel and Airbnb, and a new tuckshop, take-aways and restaurant can provide refreshments and food to visitors.

Figure 2.2.8: Site key plan (Author 2017)

Table 2.2.1: The programmatic layout of the tourism functions (Author 2017)



PROGRAMME	COLOUR	LOCATION	AMENITIES	FUNCTIONAL REQUIREMENT	NO. OF STAFF	NBR OCCUPANCY
<b>AirBnB Accommodation</b>		11 Tulleken Street	Amenities as per host	Bedding, ablutions, kitchen facilities	Host Cleaner x 1	
		25 Rider Haggard Street				
<b>Youth Hostel</b>		15 & 17 Tulleken Street	Single rooms (x 2)	Double bed and built-in cupboard	Host x 1 Cleaners x 4	<b>H2: Dormitory</b> 1 person/ 5m <sup>2</sup>  <b>Provision of sanitary fixtures</b> (SANS 10400): Population up to 20: <b>Male:</b> WC x 1, UR x 2, WHB x 2, SHR x 2 <b>Female:</b> WC x 3, WHB x 2, SHR x 2
			Dormitories (x 2)	Male: 2 x bunkbeds, lockable cupboard Female: 4 x single beds, lockable cupboard		
			Ablutions	Male/ Female: Toilets, basins, urinals, showers		
			Communal kitchen	Cooking utilities, scullery		
			Laundry	Washing machines, tumble dryers		
			Dining hall	Seating for approx. 15		
			Lounge/ Games room	Seating, TV's, pool table, foosball		
<b>Tourist Information Centre</b>		19 Tulleken Street	Information office	Consultant stations, information displays, storage	Consultants x 4	<b>F2: Small Shop (&lt; 250m<sup>2</sup>)</b> 1 person/ 10m <sup>2</sup>
			NZASM Museum	Reception/ information station, exhibition	Receptionist x 1	
			Curio sales	Point of sale, product display, storage	Cashier x 1	<b>Provision of sanitary fixtures</b> (SANS 10400): <b>Public &amp; Visitors:</b> WC x 1, WHB x 1 <b>Personel up to 15:</b> • Male: WC x 1, UR x 1, WHB x 1 • Female: WC x 2, WHB x 1
			Staff toilet	Unisex: Toilet and basin	Cleaner x 1	
			Restaurant	Reception, seating, kitchen, scullery, storage, refuse yard, deliveries	Manager x 1, hostess x 1, waiters x 10, chef & kitchen staff x 14	<b>A1: Entertainment &amp; Public Assembly</b> 1 person/ m <sup>2</sup>
<b>Tuck Shop &amp; Take-aways</b>		21 Tulleken Street	Lockable sales booth	Product display, beverage fridges, warmer cabinet, point of sale, circulation to kitchen & refuse yard	Cashier x 2	<b>Provision of sanitary fixtures</b> (SANS 10400): <b>Public &amp; Visitors:</b> • Male: WC x 1, WHB x 1 • Female: WC x 1, WHB x 1 <b>Personel up to 15:</b> • Male: WC x 1, UR x 1, WHB x 1 • Female: WC x 2, WHB x 1
			Seating area	Tables, benches, umbrellas, garbage bins		
<b>Public Toilets/ Staff facility</b>		At the back of 19 Tulleken Str	Male toilets	Toilets, basins, urinals	Cleaners x 3	<b>New building</b> to serve the Tourist Information Centre (including the restaurant), Tuckshop and public visitors, as well as all staff:  <b>Public &amp; Visitors:</b> • Unisex disabled toilet: WC x 1, WHB x 1 • Male: WC x 1, UR x 1, WHB x 1 • Female: WC x 2, WHB x 1 <b>Staff up to 30:</b> • Male: WC x 1, UR x 2, WHB x 2 • Female: WC x 3, WHB x 2
			Female toilets	Toilets, basins, baby changing station		
			Unisex disabled toilet	Toilet and basin		
			Staff facility	Ablutions: Toilets, basins, urinals, lockers Recreational area: Seating		

## 2.2.7 PROFILE OF THE MODEL TOURIST AND COMMUNITY MEMBER

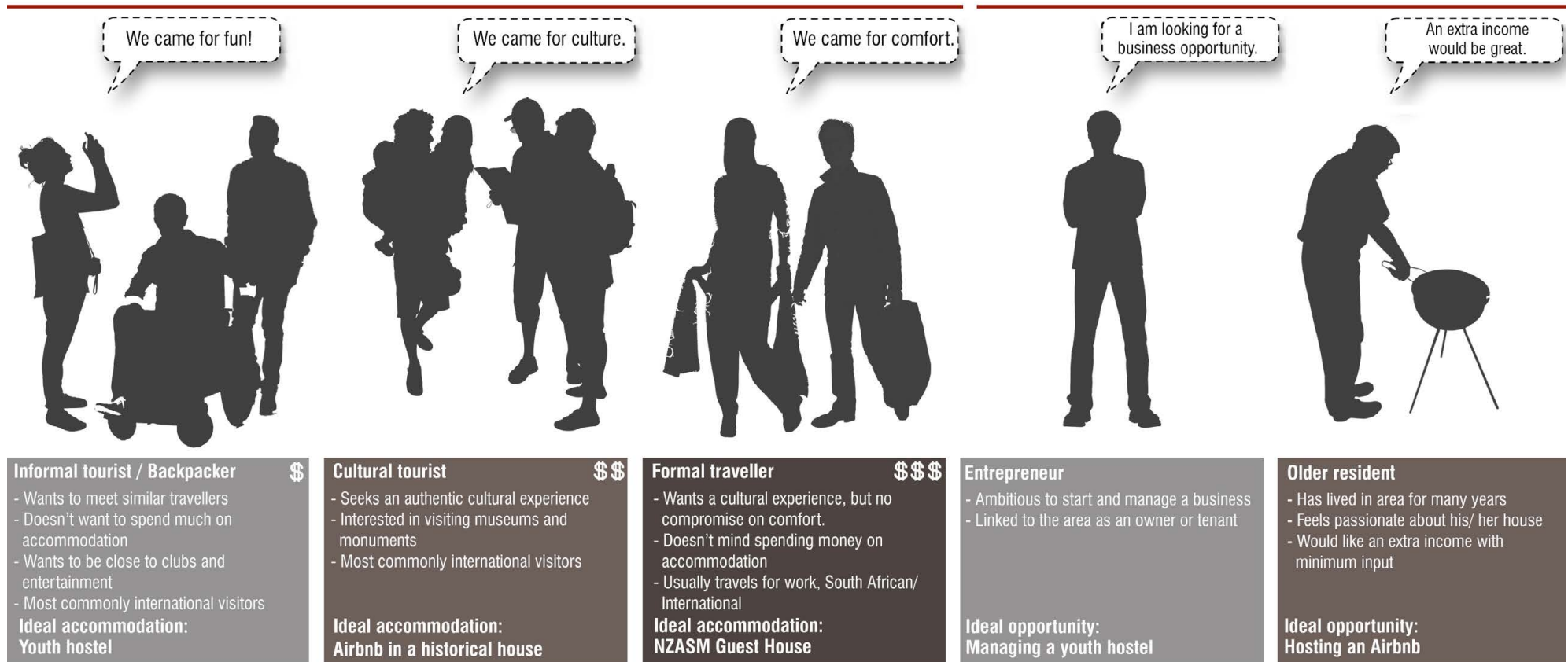


Figure 2.2.9: The profile of the model tourist (Author 2017)

Figure 2.2.10: The profile of the model community member (Author 2017)

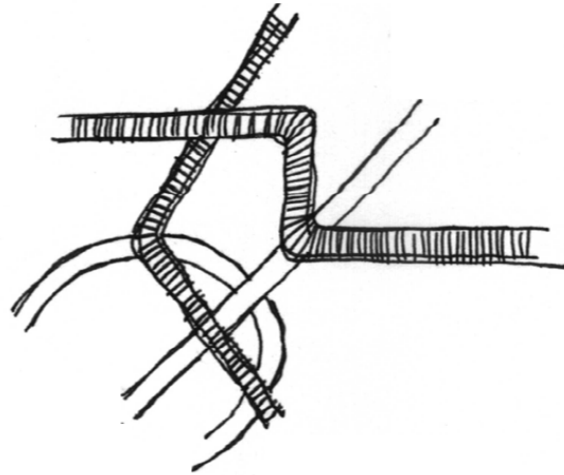
## 2.2.8 CONCLUSION

This chapter shows how the study area developed over time, and how the houses here have similar typologies to other NZASM railway house designs. Also present in this chapter is an analysis of the study area, with information on existing functions, the community, social and natural conditions. A heritage analysis of the relevant study houses is also presented, with guidelines for altering heritage fabric derived from a statement of significance.

From this information, a clearer understanding as to how and why a tourist precinct would benefit the area is given. Figures and discussions as to how this area lends itself to cater for tourists, and the kinds of tourists it might attract is also provided.



# CHAPTER 3: THEORY







### 3.1 INTRODUCTION

This chapter investigates theories on heritage, resilience and tourism in an endeavour to establish a regeneration strategy for the documented houses within their specific context. The aim is that the strategy generated can be applied to the study site, as well as to similar contexts of endangered dwellings in other locations. Through investigating current literature, it was found that theoretical overlaps exist. For example, the concepts of heritage and cultural tourism, and sustainable community development interlink (Ursache 2015:133).

Heritage as a theoretical topic forms part of this review, particularly with relation to the age and nature of the houses (refer back to Section 2.1.4 and Figures 2.1.12 to 2.1.19 in Chapter 2). An appropriate stance to the alteration of the heritage fabric is required when alteration is proposed. Resilience of the area, built fabric and resident community needs to be strengthened to ensure the continued existence of the heritage fabric, and to enable the successful integration of a new function, further

substantiating the importance of theories on resilience (Peres, Barker and Du Plessis 2015:2). Tourism is also investigated in this review as a choice of new function for the specific site and as a means of revitalising the area through the adaptive reuse of the structures.

Relevant literature was sourced from the University of Pretoria library and published articles. The outcome of the theory investigation is to inform the design approach to the introduction of tourist amenities by strengthening the resilience of the heritage fabric and the resident community. In the sections that follow, heritage, resilience and tourism are dealt with separately. Thereafter, connections are drawn and an overarching approach that incorporates all three aspects is outlined in the conclusion of the chapter.

**Figure 3.1 Chapter cover page:** *Conceptual drawing of theoretical overlaps (Author 2017)*

# PART 1: HERITAGE

Theories on altering historic fabric from Brooker and Stone (2004), the Burra Charter (ICOMOS 2013) and Scott (2008) are investigated. A literature review by Plevoets and Van Cleempoel (2011) on the subject of adaptive reuse as a strategy towards cultural heritage conservation informed this choice of theorists. Plevoets and Van Cleempoel (2011) discuss Brooker and Stone's approach (2004) as an example of where the original building is the most important and decisive factor in adaptive reuse, and Scott's (2008) approach as one that takes the historic theories of Ruskin and Viollet-le-Duc into account (Plevoets and Van Cleempoel 2011:8).

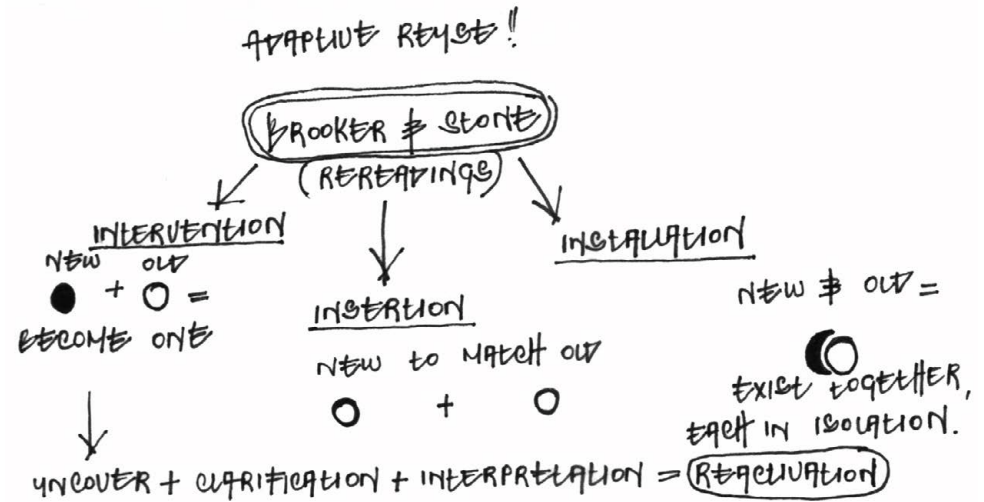
## 3.1.1 ALTERATION: LICENCE TO CHANGE

*When a place is lifeless or unreal, there is almost always a mastermind behind it. It is so filled with the will of its maker that there is no room for its own nature (Alexander 1979:36).*

Preserving the nature of the existing built fabric is the primary objective of the intended alteration. According to Brooker and Stone (2004:79), the original building and its relationship with the new is the most influential device in design. The authors introduce three strategies to alteration, namely intervention, insertion and installation, as depicted in Diagram 3.1.1 (Brooker and Stone

2004:79). Intervention can be defined as an alteration that is wholeheartedly accepted by the original building and where an intimate relationship is established, in which the old and new become one (Brooker and Stone 2004:79). Insertion is where an intense relationship is established between the old and the new, but where each exists independently; the new drawing inspiration from the qualities of the old (Brooker and Stone 2004:102). Installation is the act of adding the new within the context of the old, where both exist independently, simply touching on the concept of the other (Brooker and Stone 2004:127).

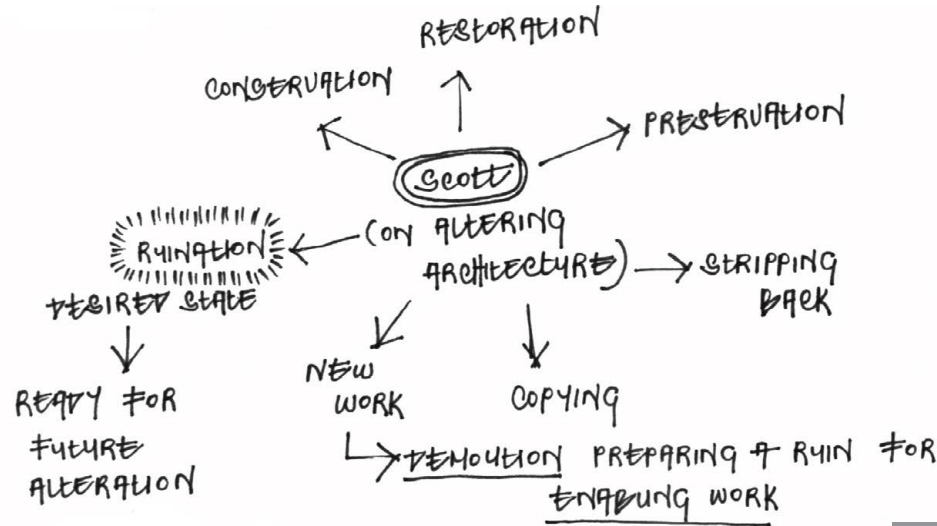
Intervention is undertaken as an adaptive reuse strategy to address the identified problem in this study, due to the envisioned level of integration between the host building and the new fabric. For this study, then, the aim is for the original to accept the new, leading to a singular design product where old and new are read as one (Brooker and Stone 2004:97). Brooker and Stone (2004:81) elaborate on the process of intervention as the building being regarded as a narrative; a story to be discovered and retold. Through a process of uncovering, clarification and interpretation a place will be revealed and reactivated. The analysis and reading of the structure can often be as destructive as it is constructive; as the designer will strip away, clarify and undo additions in order to reveal



3.1.1

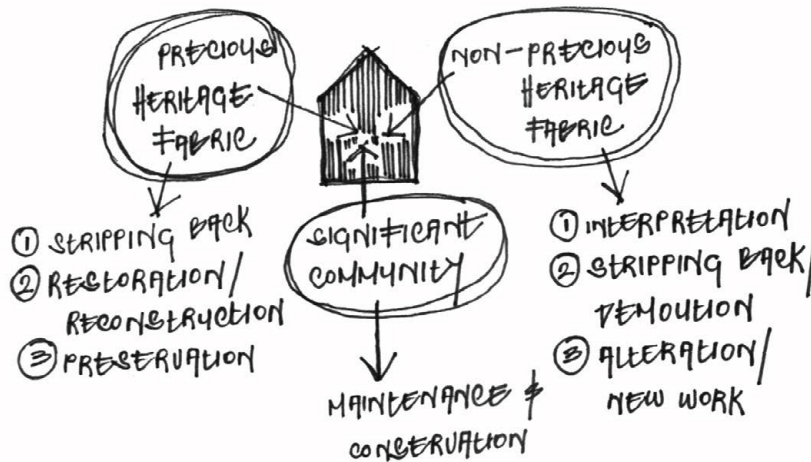


3.1.2



3.1.3

COMBINED STRATEGY



3.1.4

new and hidden meanings.

The Burra Charter (ICOMOS 2013:6), in turn, outlines different conservational processes (see Diagram 3.1.2) of which some move towards the original concept, while others have the freedom to be reinterpreted and move away from the original. For example, maintenance and preservation will always be aligned with the idea of the original fabric, while new work and adaptation can introduce a new concept, thereby re-invigorating the built fabric with a new and more relevant purpose. Scott's (2008) theory also deals with different approaches to the alteration of heritage fabric. Here, the desired state of alteration is ruination, where the ruin has been prepared for inevitable future alterations. Scott (2008:212) states that incompleteness is the only clear aim of alteration, as it creates an allusion to the ideal and allows the building to become an element of continuity. This idea of the 'perfect incomplete' can be linked directly to the resilience of a built structure being able to accommodate future alterations and functions. This idea is represented in Diagram 3.1.3.

Different approaches can be taken to dealing with different fabrics of the same structure, leading to a combined strategy in heritage alteration (see Diagram 3.1.4). A statement of significance, as defined by the Burra Charter (ICOMOS 2013:4), helps to identify between precious heritage fabric and non-precious heritage fabric. Precious

heritage fabric can be dealt with by stripping back past add-ons from the original, thereby restoring, reconstructing and preserving the original fabric. Non-precious heritage fabric can be handled in a less sensitive manner, with the objective of preparing it to accommodate a new function (ICOMOS 2013:4). In this case, the fabric can be re-interpreted, stripped back or demolished as necessary in preparation for the new, and then altered. The community residing in these heritage structures (whether precious or non-precious) forms part of the cultural landscape and their spiritual significance should be maintained and conserved through a process of participation (ICOMOS 2013:5).

Altogether, the Burra Charter (ICOMOS 2013) serves as a tool of identifying precious heritage fabric and establishing their significance, while Brooker and Stone (2004) provide the overall strategy for alteration and Scott (2008) identifies a clear outcome to heritage alteration. The story of the building is thus read, altered, reshaped, retold and often irretrievably changed through the process of alteration (Brooker and Stone 2004:83).

**Diagram 3.1.1:** Brooker and Stone's strategies for alteration (2004:79)

**Diagram 3.1.2:** The conservation processes as outlined in the Burra Charter (2013:6)

**Diagram 3.1.3:** Scott's approaches to alteration (2008)

**Diagram 3.1.4:** The combined strategy to heritage alteration (Author 2017)

# PART 2: RESILIENCE

## 3.2.1 URBAN RESILIENCE AND REGENERATION

Urban resilience can be defined as the capacity of a city to absorb or adapt to change brought about by slow pressures or rapid pulse disturbances (Peres et al. 2015:2). Cities can experience both 'positive resilience', brought about through healthy diversity (e.g. alternative roads to avoid traffic jams), or 'negative resilience', brought about through lock-in (e.g. politics stalling the provision of well-located affordable housing and amenities) (Peres et al. 2015:2).

A socio-ecological perspective to resilience, also known as 'evolutionary resilience', recognises that complex systems are in constant change, with no equilibrium state to which to return or from which to move forward following a disturbance (Suárez et al. 2016:2). The focus of such resilience is rather on the capacity of learning, and being innovative and flexible. The main idea of the perspective then consists of an acceptance of the permanent state of imbalance in which systems exist.

Frameworks have been developed to measure socio-ecological urban resilience. The social and economic dimensions are measured through data like household income, employment, health coverage, age and educational level (Suárez et al. 2016:2). The physical and infrastructure

dimensions refer to the resilience of houses and infrastructures, such as electricity, water and communication systems (Suárez et al. 2016:2). Overall urban resilience can be measured through diversity, modularity, tightness of feedbacks, social cohesion and innovation (Suárez et al. 2016:3). Such urban resilience is illustrated in Diagram 3.2.1.

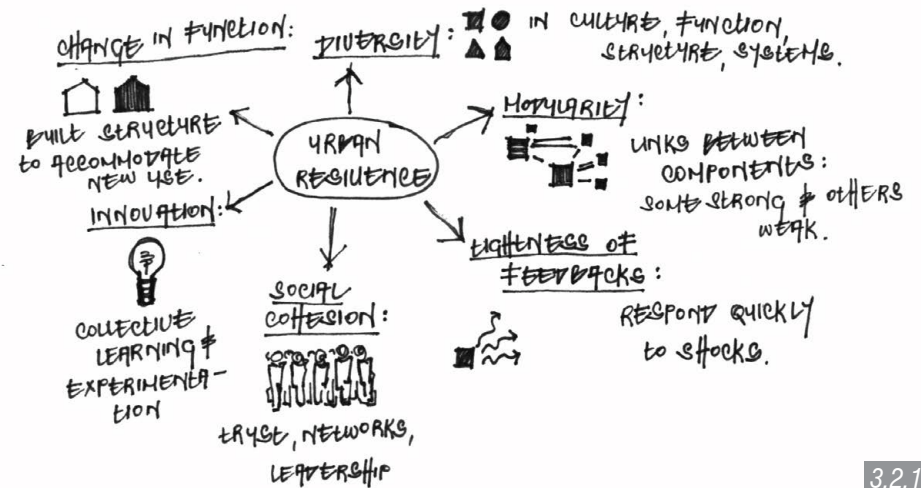
In the process of creating a thriving city, it may be necessary for a system to collapse and regenerate (Peres et al. 2015:2). According to Du Plessis (2013:38), the responsibility is placed on professionals hoping to be 'resilient and regenerative' to identify which aspects may need to collapse in order to provide room for new life to take root in a site's latent potential. This relates to the idea of stripping back built fabric to accommodate new functional requirements (refer back to Diagram 3.1.1).

Identifying heritage fabrics for conservation forms part of a site's potential and leads to the creation of a historic sense of place. The possibility of new work then strengthens the resilience and relationship between old and new, thereby informing the approach towards a regeneration strategy.

EVOLUTIONARY RESILIENCE: CONSTANT CHANGE, NO EQUILIBRIUM STATE



CHANGE  
BOUNCES BACK



3.2.1

### 3.2.2 COMMUNITY SUSTAINABILITY

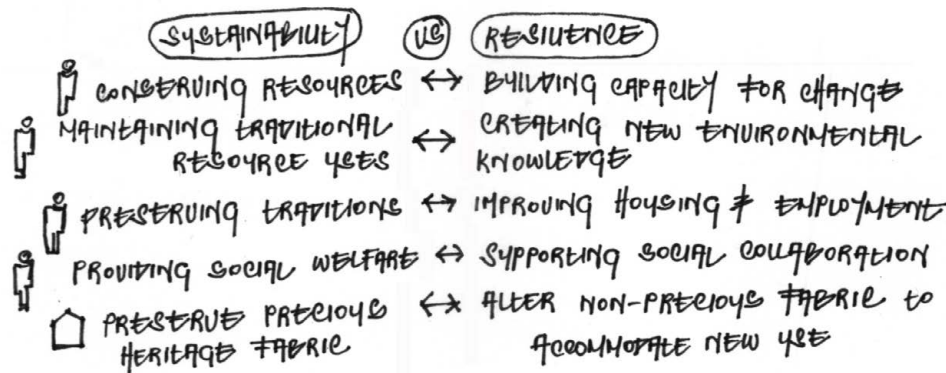
The ideal community is both sustainable and resilient, with the understanding that the two concepts exist in distinct conceptual paradigms (Lew et al. 2016:20). Sustainable development is best defined in terms of its core goals of protecting and maintaining natural and cultural resources for the future, as well as mitigating undesirable change (Lew et al. 2016:21). The most important similarity between sustainability and resilience is the goal of system survivability (Lew et al. 2016:22). This understanding has led to this study's presented research question about how to ensure the survival of the NZASM houses. According to Lew et al. (2016), the following questions can be asked of a resident community in relation to sustainability and resilience: a) Sustainability: What does the community want to conserve and how do they want to conserve it? and b) Resilience: What does the community want to change and how do they want to change it? Diagram 3.2.2 unpacks the difference in indicators for community sustainability and resilience.

able they are. Similarly, the better a community can adapt and change in areas that they want to see developed, the more resilient they are (Lew et al. 2016:24).

All existing communities already possess a certain degree of sustainability and resilience. The community in question has experienced organic changes in the diversity and culture of its residents, as well as in the use of the houses, where some have changed from residential to partly or fully commercial properties, while others have changed to fulfil public community-orientated functions. With these changes, however, the community has not endeavoured to preserve the precious heritage fabric over the past decades. The implementation of a strategy, such as that proposed in this study, aimed at educating the residents of the houses regarding heritage value and improving the sustainability of the heritage fabric on site is, therefore, clearly needed.

**Diagram 3.2.1:** Measurements of urban resilience (Suarez et al. 2016:3)

**Diagram 3.2.2:** Community sustainability is compared to resilience (Lew et al. 2016:22)



### 3.2.2

In broad terms, it can be stated that the better a community is able to conserve and sometimes recover that which they cherish, the more sustain-

# PART 3: HERITAGE AND CULTURAL TOURISM

## 3.3.1 DEVELOPING A PLACE IDENTITY

Tourism is an activity related to cultural and natural heritage, as well as to traditions and contemporary cultures. The continuous processes of communication, negotiation, resistance and adaptation are significant for those who identify with a particular culture (Ursache 2015:134). A sense of place can be created and evolved into a future identity for a site. Heritage is a key mechanism in the process of how people remember and interpret the past, how they use it to create their own sense of time and place and transform this sense into a place identity (Ennen and Van Maanen 2014:50). A place identity is the memory that remains with visitors long after they have left the attraction, and can be shaped by carefully designing the tourist experience.

The creation of an identity or local brand also lies with the resident community. Tourism can be influential in generating a sense of pride and a desire to develop resources (Ursache 2015:133). By drawing from the existing cultural, traditional, natural and heritage qualities of the site, an existing experience can become richer. In place-identity terms, public space should be designed as highly connected networks rather than a system of isolated enclave spaces (Butina-Watson and Bentley 2007:263). The part/whole relationship plays a

significant role in ensuring that the identity of an attraction jumps between scales and is rooted in every detail of the destination.

## 3.3.2 SUSTAINABLE TOURISM

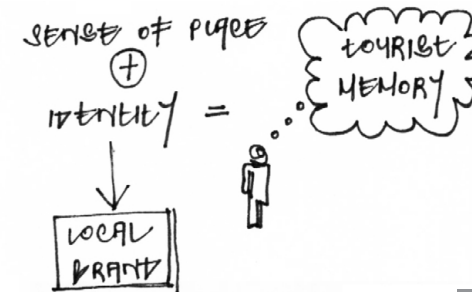
Sustainability has the potential to bring heritage preservation, tourism and economic development into a balanced relationship with each other (Ursache 2015:133). From a social-cultural point of view, tourism can be a force for stability in a community, as depicted in Diagram 3.3.1 (Ursache 2015:133). Tourism activities raise awareness about the social and cultural values of local residents, and through tourist appreciation of natural and cultural heritage the community is educated regarding the importance of preserving significant fabric (Ursache 2015:134). A community can be uplifted through tourism that creates job opportunities, and educated through inter-cultural exchanges with tourists (see Diagram 3.3.2). Such interactions can lead to the kind of tourism that can be sustained.

The management of heritage tourism comprises of a conservation goal with financial and public access constraints (Garrod and Fyall 2000:684). Financial support for maintenance is even more important in heritage settings, as old buildings are more prone to natural decay and negative user impacts. A balance is required between conservation

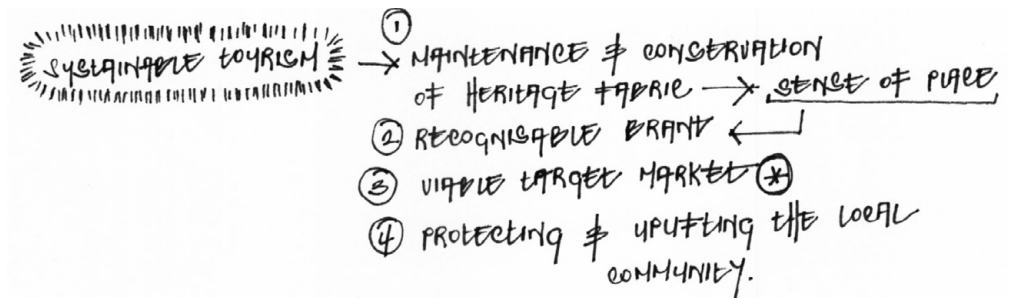
and contemporary use, the extent of public education and the relationship between the built heritage, and tourists and the local community (Garrod and Fyall 2000:702). According to Ursache (2015:13), a lack of urban master planning often causes a disconnection between the architectural style of new buildings and that of the originals. This disconnection can negatively affect the sense of place. A holistic approach must therefore be taken to ensure an identifiable tourist destination.

**Diagram 3.3.1:** The creation of a place's identity (Author 2017)

**Diagram 3.3.2:** A summary of the meaning of sustainable tourism (Author 2017)



3.3.1

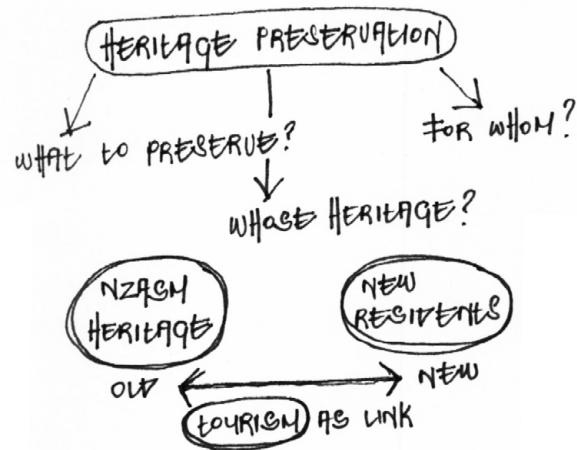


3.3.2

### 3.3.3 HERITAGE AND CULTURE

Heritage is defined as an individual or collective interpretation of elements of the past. In culturally and ethnically diverse communities, the following become pertinent questions: a) What should be preserved? b) Whose heritage should be preserved? and c) For whom should this heritage be preserved? (Ennen and Van Maanen 2014:45). Heritage is often a manifestation of the dominant group in an attempt to safeguard values, standards, identity and history of their own (Ennen and Van Maanen 2014:45). Community engagement is crucial to the development of a heritage attraction, and Garrod and Fyall (2000:703) state that if the present generation is not allowed access to heritage structures, such structures will cease to be a relevant part of their heritage, leading to a decrease in cultural richness and resources.

The community around Tulleken and Rider Haggard Streets is diverse and constantly changing, which means that the community currently on site will look different ten years from now. When selecting what to preserve, the future of the site must be kept in mind. The narrative of the Nederlandse Zuid-Afrikaansche Spoorweg-Maatschappij (NZASM) heritage is therefore extended in this study to include the culture and heritage of new residents, with tourism becoming the link between the past and the present (see Diagram 3.3.3).



3.3.3

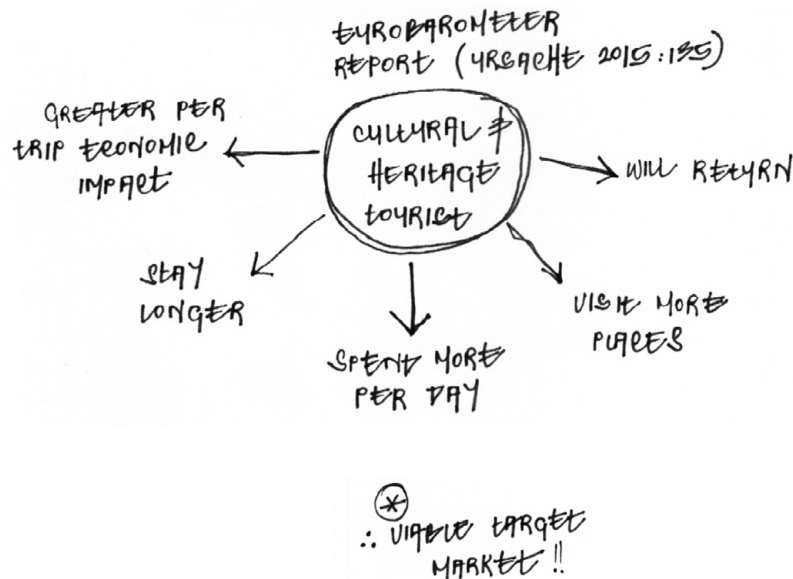
### 3.3.4 THE TARGET MARKET

The envisioned visitor to the NZASM tourist precinct will be interested in experiencing a culturally rich community in an authentic setting. According to the Eurobarometer report (see Diagram 3.3.4), which measures the preferences of European tourists, a quarter of respondents mentioned culture as one of their main reasons for travelling, and nearly half of the respondents said that natural, cultural and historical attractions would make them return to a destination (European Commission 2014:11). Furthermore, heritage visitors tend to stay longer, visit twice as many places, spend more per day and, by extension, have a meaningfully greater per trip economic impact on the destinations they visit (Ursache 2015:135). This could greatly benefit this study's community through increased economic opportunities.

It is evident that tourists seeking a cultural and heritage experience are the most viable target market in the development of sustainable tourism. Through the development of the heritage features embedded in the fabric of the specific site, and the inclusion of an appealing narrative, a successful tourist destination can be established.

Diagram 3.3.3: Tourism as the link (Author 2017)

Diagram 3.3.4: The cultural and heritage tourist as viable target market (Ursache 2015:135)



3.3.4

### 3.4. REGENERATION STRATEGY

A regeneration strategy is devised for the specific site, consisting of principles developed through the analysis of the structures and subsequent statement of significance in Chapter 2, the theory investigation in Chapter 3, and the case study and precedent analysis in Chapter 4. The strategy can be adapted to regenerate similar domestic heritage contexts by analysing the specific heritage fabric and the social conditions on site, and introducing a new appropriate function that would promote the area's resilience and sustainability.

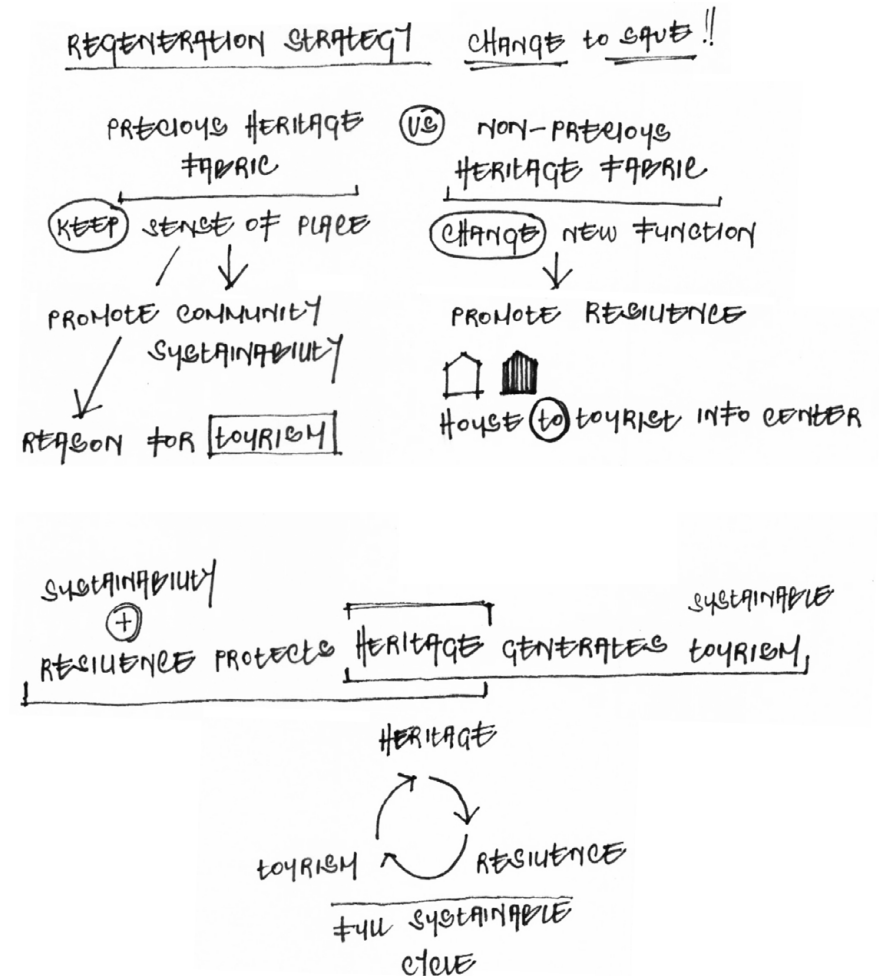
The first step in the strategy is the identification of heritage fabric. A statement of significance (please refer back to Section 2.1.15 in Chapter 2) generated through an analysis of the specific built structures has enabled the identification and separation of precious heritage fabric from non-precious heritage fabric at the site. Precious heritage fabric is identified as true to the era from which it dates, is original to the structure and possesses a certain rarity (ICOMOS 2013:2). Such fabric should be maintained and celebrated because it can aid in establishing a new sense of place or can even be used to stimulate the creation of a local brand, such as in the case of the Bo-Kaap (please refer to Section 4.3 in Chapter 4), as a living tourist destination. Keeping and maintaining what is precious in terms of heritage value and what is significant to the community also promotes the sustainability of resources for the future, and subsequently

creates the continued reason for why tourists may visit a destination.

In contrast, the identified non-precious fabric can be changed to accommodate a new function, thereby promoting the resilience of the built structures. Intervention is proposed as the approach to alteration at the study site, as this approach allows the new to become one with the old. Through a narrative process of uncovering, clarifying and interpreting, the place will be revealed and reactivated (Brooker and Stone 2004:81). When a drastic change in function is required to save residential structures through adaptive reuse, the need for stripping back or demolition is justified, as is the case with this site. Additionally, the introduction of tourism as a new function for the specific site is socially relevant for the community, through the creation of jobs and recreational amenities, and the celebration of what is deemed valuable.

A sustainable and resilient community will protect the heritage of the built environment and, in turn, generate a tourist attraction. A full sustainable cycle can be created through the continued maintenance of precious heritage fabric, a sustainable and resilient community, and heritage and cultural tourism, as illustrated in Diagram 3.4.1.

**Diagram 3.4.1:** *The regeneration strategy (Author 2017)*





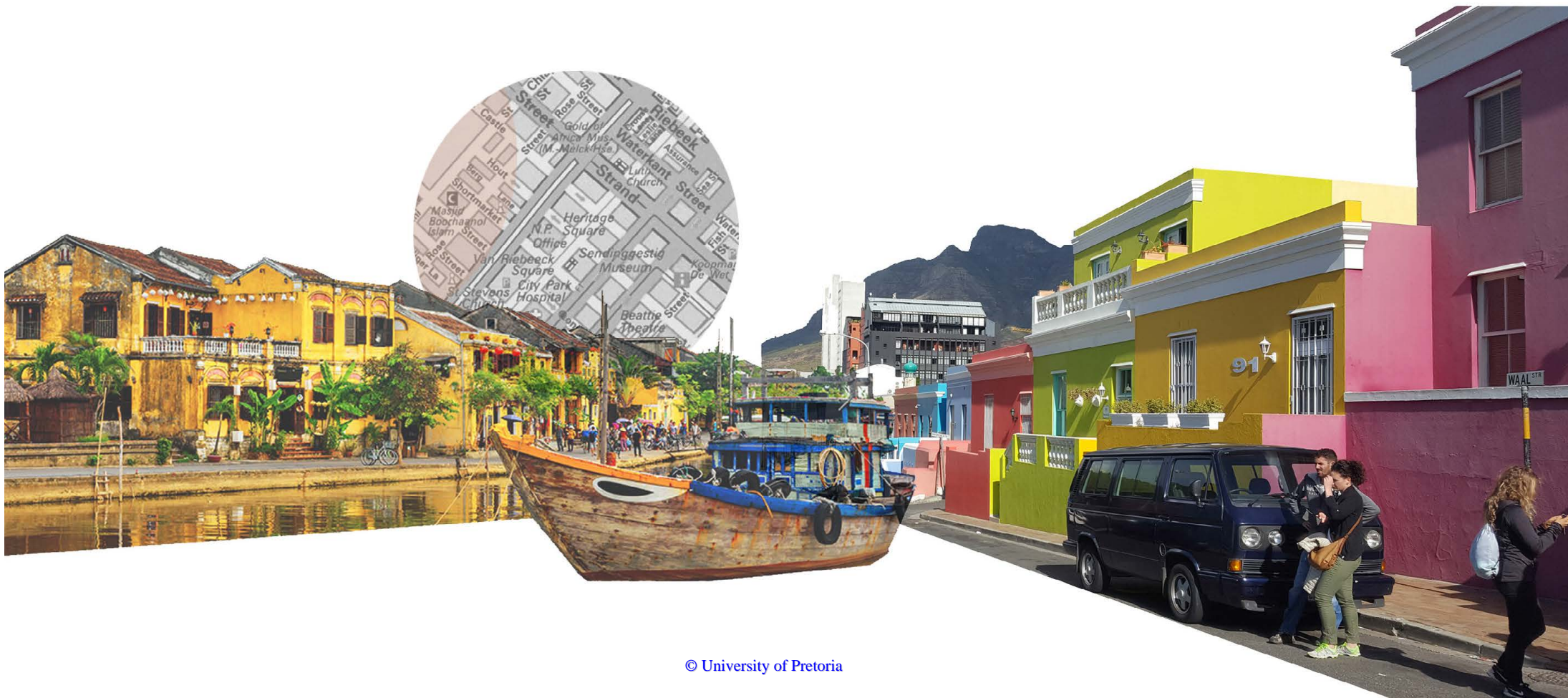
### 3.5 CONCLUSION

This chapter highlights that the theories of heritage, resilience and tourism can be linked, and that by promoting one of the three themes, the other two will also benefit as result. A resilient and sustainable community is the key to preserving precious heritage fabric, which in turn can promote heritage and cultural tourism.

The introduction of tourism can be considered a viable catalyst to regenerate the specific site. Tourism can also work to acknowledge and celebrate the cultural significance of the historical residential structures and community, while ensuring their continued existence.



# CHAPTER 4: CASE STUDIES AND PRECEDENTS





## 4.1 INTRODUCTION

The following section investigate case studies in similar settings that of the study site, so as to establish design guidelines. Groat and Wang (2002:418) define a case study as an empirical inquiry that investigates a phenomenon or setting in its real-life context.

The following are characteristics of a case study (Groat and Wang 2002:419):

- The focus is on single or multiple cases in their real-life contexts;
- It has the capacity to explain:
  1. Causal links; and
  2. The importance of theory development in the research design phase.
- It relies on multiple sources of evidence, with data converging in triangular fashion; and
- It has the power to generalise to theory.

Local and international precedents serve as design informants and inspiration for architectural studies. Joroff and Morse (1984:22) state that architects review precedents during the design phase as an assessment of knowledge gained by others, rather than research in the strict definition of the term. The same approach is taken to assess what has been done in the field of the proposed study, where two case studies, three heritage precedents and three tourism programme precedents are reviewed.

**The case studies are:**

- 4.3 The Bo-Kaap, Cape Town, South Africa; and
- 4.4 Hoi An Ancient Town, Vietnam.

These case studies have both been visited by the author.

The precedents are divided under the themes of heritage and tourism as programme.

**The heritage precedents are:**

- 4.6 Hedmark Museum/Storhamar Barn, Hamar, Norway;
- 4.7 Neues Museum, Berlin, Germany; and
- 4.8 Gehry House, Santa Monica, USA.

**The precedents with tourism as programme are:**

- 4.9 Visitor Centre Emscher Village, Oberhausen, Germany;
- 4.10 Vilakazi Street Precinct, Soweto, South Africa; and
- 4.11 Tourist House, Tardets-Sorholus, France.

**Figure 4.1 Chapter cover page:** *Conceptual collage of Hoi An and the Bo-Kaap (Author 2017)*

## 4.2 THE EFFECTS OF TOURISM

Ursache (2015:134) lists the positive and negative effects of tourism on the culture of an existing community. From this starting point, a measuring scale can be derived as an evaluation method for the case studies.

**The positive impact of tourism on culture includes:**

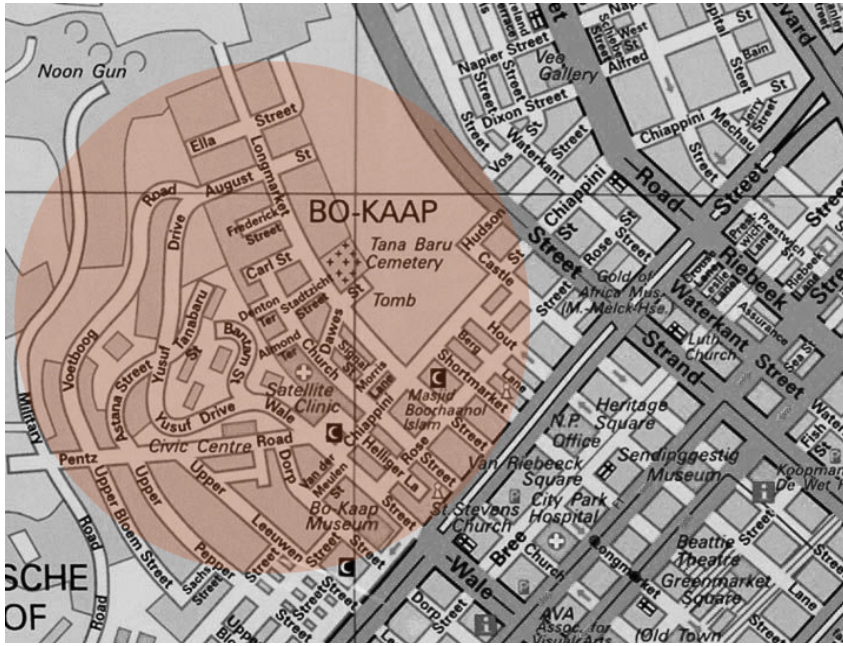
- The opportunity of capitalisation of the local goods, facilities and local **employment** opportunities;
- The revitalisation, renewal and preservation of **local culture**, traditions, customs, hand-crafts, art, identity and heritage;
- The improvement of the **living conditions** of residents;
- The diversification and improvement of **recreational facilities**;
- Greater recognition of the importance of **preserving historic buildings**;
- The support of **infrastructure development**;
- The creation of meaningful **inter-cultural exchanges** between residents and tourists.

**The negative impact of tourism on culture includes:**

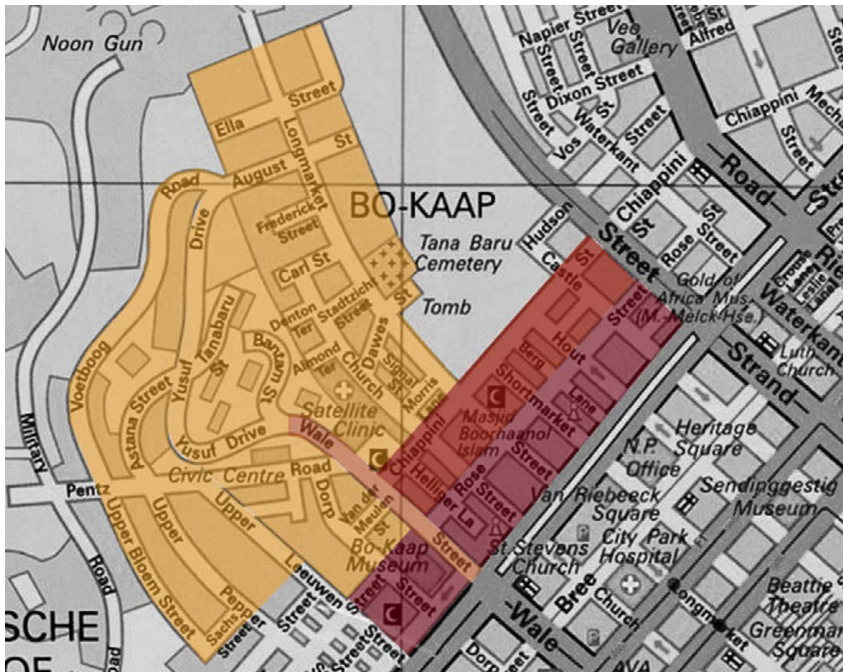
- Residents may abandon their traditional culture and values to become part of an attractive **“holiday culture”**.

- Residents may experience a **feeling of alienation** from the changes taking place in their neighbourhood.
- Residents may experience a loss of privacy and **degradation of original life quality**.
- **Loss of authenticity** may result from the fact that tourists cannot fully understand the local culture and traditions or do not have time to appreciate it.
- A **lack of architectural urban planning** while developing the tourism sector may result, which could affect the cultural appearance of the area. Excessive development can also generate hyper urbanisation.
- Tourism **affects urban systems**, causing possible overcrowding – especially in central areas.
- An increase may occur in **social problems** to which both tourists and residents may be exposed. For example, an increase in crime (such as pick-pockets, robbery, illegal business); drug trafficking and prostitution; disease (such as HIV/AIDS); and abuse of the human rights and exploitation of vulnerable groups. The social body can also be affected by servile behaviours, inferiority complexes, coercion, moral and cultural perversion, distortion of traditional practices, changes in traditional social structures and loss of value of the long-term attractiveness of the tourist area.

### 4.3 CASE STUDY 1: THE BO-KAAP, CAPE TOWN, SOUTH AFRICA



4.2



4.3

#### Transition of space

- Wale street: Traditional functions \_ Public
- Rose street: Contemporary commercial functions \_ Public
- Chiappini street: "Hollywood street" \_ Semi-public
- Residential streets: Semi-private to private

There are many versions of the story of the reason for the different colours used on the houses of the Bo-Kaap. The true version, according to the Cape Town Free Walking Tours tour guide, Daniel, is that the houses were painted in celebration after the political victory in 1994. This painting was done as a method of drawing attention to the neighbourhood, originally consisting of dwellings for house slaves, resembling white boxes. The houses are built up to the pedestrian walkway and have no backyard, for optimum use of living space. The façades are void of decoration and local, economic materials are used in their construction. The street materials are a mix of historic cobblestones laid by slaves as well as modern paving and tar.

The Bo-Kaap is well located next to the CBD (see Figure 4.2). As a result, property value has increased and the original community is slowly being bought out and replaced by businesses. This occurrence has led to a loss of authenticity, with the original community slowly shrinking. The street closest to the CBD, Rose Street, has become mostly commercial, with contemporary shops promoting local design (for example Mevrou & Co.), restaurants and coffee shops (for example Deluxe Coffeeworks and Batavia Cafe,

see Figure 4.3.4) and guest houses lining the street. Wale Street (see Figure 4.5), which runs perpendicular to Rose, is more traditional, with the Bo-Kaap Museum, Atlas Trading Spice shop, Biesmiellah Restaurant (see Figure 4.6), cooking classes offered in one of the houses and a craft shop. The next street running parallel to Rose Street is Chiappini Street, otherwise known as 'Hollywood Street'. Chiappini Street (see Figure 4.8) is the most photographed street in Cape Town, and is often used in films and commercials, due to the colours of its houses being generally well-maintained. Moving up the hill, the area becomes completely residential and a sense of privacy exists that is not present in the lower streets of the Bo-Kaap.

One can describe this transition from public to private as staggered (see Figure 4.3). A tourist immediately knows where he/she is welcome and where they have overstepped the boundary into the private residential area. With two tours per day, every day of the year, a buy-in from the community is required to realise a successful tourist attraction in a residential area.

The Bo-Kaap Museum (see Figure 4.10) is realised in a typical historic house that has been adapted into a museum. This museum presents the history of the area through information panels, a video and objects exhibited in glass cases. To

the back of the house lies an underutilised spill-out area, and the small museum can be experienced in 20 minutes or less. The house has been fitted with a new glass entrance door that also serves as an information panel installed behind the original wooden front door. The entrance foyer of the house is used for ticket sales, as well as a pause/ waiting space. The four rooms, two on each side of the foyer, serve as exhibition spaces, with LED cable lights overhead. Circulation in the museum is problematic with visitors having to cross the foyer and crossing paths with the visitors waiting to buy tickets.

**The relevance of this case study to this study's design question is in its:**

- Successful transition from public to private;
- Successful insertion of contemporary functions into historic structures;
- Colour as strategy to generate interest.

**Conservation strategy:**

The street-facing façades of the houses are protected by law from any structural alterations. There are, however, street-facing alterations taking place in Dorp Street, which can be seen in Figure 4.7. Colour changes and the addition of security fixtures are permitted.

The houses in the NZASM Tourist Precinct are not specifically protected or listed, apart from being older than 60 years and being protected by the National Heritage Resources Act (Nr. 25 of 1999) (Republic of South Africa 1999). The proposed alteration of the properties will require approval from the South African Heritage Resources Agency (SAHRA) to become a tourist precinct, and thereafter a management plan can be put into place on guidelines for altering heritage, specifically for the owners and tenants of the heritage structures. This is done in order to ensure that a cohesive precinct is maintained.

Figure 4.2: The Bo-Kaap marked on a map of Cape Town (Maps Company 2014)

Figure 4.3: The transition of space from public to private (Maps Company 2014)

Figure 4.4: The Batavia Cafe in Rose Street (Author 2017)

Figure 4.5: View from the top of Wale Street (Author 2017)

Figure 4.6: Biesmiellah Restaurant (Author 2017)

Figure 4.7: An alteration in Dorp Street (Author 2017)

Figure 4.8: The view of Chiappini Street (Author 2017)

Figure 4.9: Different sidewalk and road materials (Author 2017)

Figure 4.10: Interior view of the Bo-Kaap Museum (Author 2017)



4.10



4.4



4.6



4.8



4.5



4.7



4.9

#### 4.4 CASE STUDY 2: HOI AN ANCIENT TOWN, VIETNAM

Hoi An Ancient Town is a well-preserved example of a small-scale trading port, active from the 15th to the 19th century, in Vietnam. Its decline at the end of the 19th century ensured that it has preserved its traditional urban tissue to a remarkable degree.

The town consists of a well-preserved precinct of 1,107 timber frame buildings, with masonry or wooden walls (see Figure 4.13). The roofs are tiled and the wooden components are carved with decorative traditional motifs. The buildings are arranged side-by-side in tight, unbroken rows along narrow pedestrian streets (see Figure 4.14). There is also a wooden Japanese bridge, with a pagoda on it, dating from the 18th century, as well as an open market and a ferry quay (UNESCO 1999).

Today, most of the buildings in the original complex have commercial functions. For example, many of the buildings have been converted into restaurants or clothing and leather shops, with religious buildings, such as pagodas, in-between (see Figure 4.15).

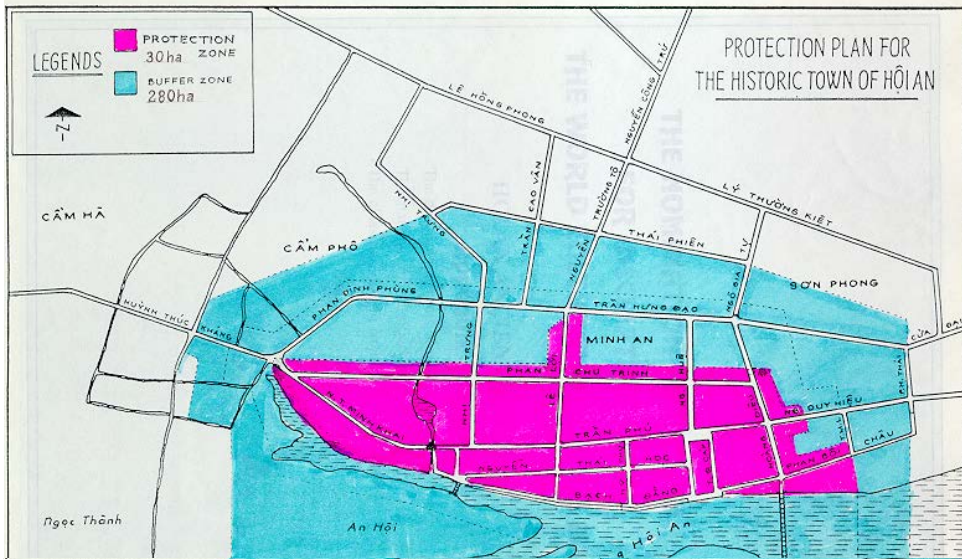
The original wooden structures require repair at intervals, thus many buildings with basic structures from the 17th and 18th centuries were restored in the 19th century using traditional methods of repair. UNESCO states that there is currently no pressure to replace older buildings with new ones in modern materials (UNESCO 1999).

Hoi An Ancient Town was classified as a National Cultural Heritage Site in 1985 and, subsequently, as a Special National Cultural Heritage Site under the Cultural Heritage Law of 2001, amended in 2009 (UNESCO 1999). The entire town is state-owned. Long-term management aims to promote improvement in the living conditions for local residents. As tourism increases, a strategy to manage it within the parameters of the site will be required.

The original street plan, which developed as the town became a port, remains. It comprises a grid of streets with one axis parallel to the river and the other axis of streets and alleys set at right angles to it (see Figure 4.11). Typically, the original commercial buildings front the streets for convenient customer access, while the backs of the buildings open to the river, allowing for easy loading of goods from boats (UNESCO 1999).



4.11



4.12



The relevance of this case study to this study's design question is in its:

- Use of culture and tradition as the biggest drivers in creating a successful tourist attraction;
- Approach to inserting contemporary functions into historic structures as superficial, with no lasting changes made to the space. This is positive for the protection of the structure; and
- Measures taken to protect precious heritage fabric against possible damage by high quantities of tourists using the space.

**Conservation strategy:**

All properties are state-owned, with maintenance and conservation of the historic structures being managed by the state. The maintenance timelines could lead to the daily wear-and-tear not being addressed frequently enough. The buildings in the NZASM Tourist Precinct will remain privately owned, with conservation and maintenance guidelines put into place. This will form part of the management of the site.

**Figure 4.11:** A tourist map of the ancient village of Hoi An (World Heritage Site 2010)

**Figure 4.12:** Protection Plan, dating from 1998 (UNESCO)

**Figure 4.13:** A historic house in Hoi An's main street (Author 2014)

**Figure 4.14:** The view down a pedestrian street (Author 2014)

**Figure 4.15:** Historic houses converted into clothing shops (Author 2014)

**Figure 4.16:** A decorative brick (Author 2014)



4.13



4.14



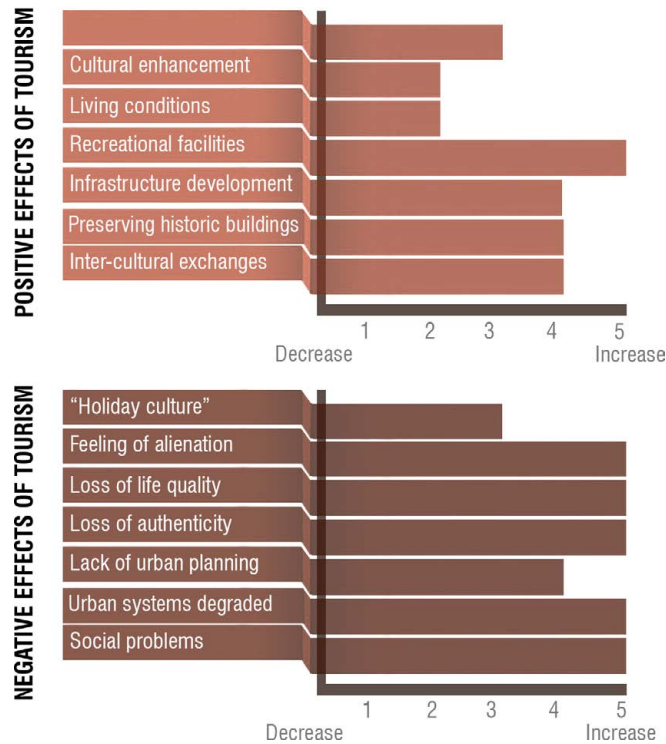
4.15



4.16

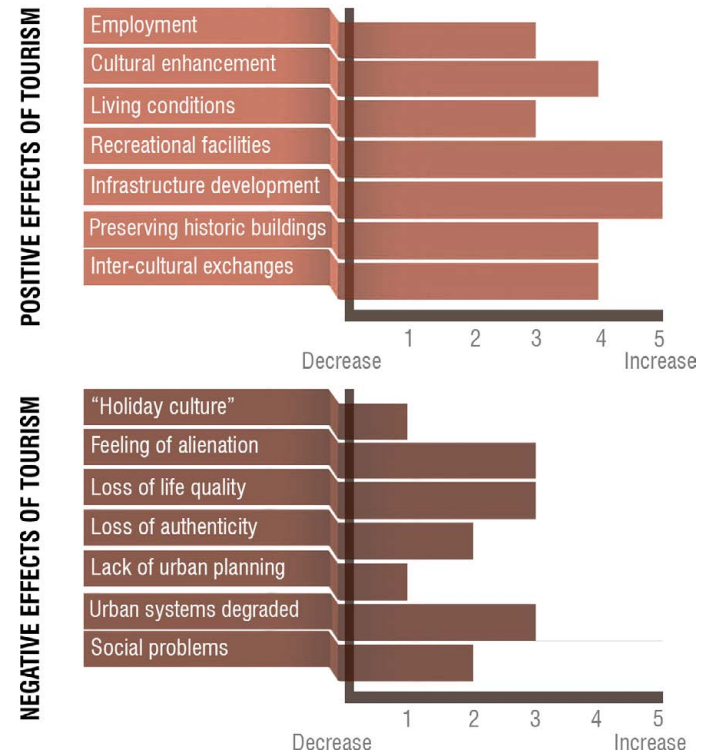
#### 4.5 MEASURING THE EFFECTS OF TOURISM IN THE BO-KAAP AND HOI AN ANCIENTTOWN

The positive and the negative effects of tourism on the culture of the existing Bo-Kaap and Hoi-An communities are evaluated through a measuring scale derived from criteria by Ursache (2015:134) (refer to 4.2).



**Figure 4.17:** *The effects of tourism evaluated for the Bo-Kaap (Author 2017)*

The most prominent positive effects of tourism in the Bo-Kaap is the increased preservation of historic buildings through attention drawn to it by the community, as well as the creation of additional recreational facilities for tourists and locals (see Figure 4.5.1). Some of the negative effects include the loss of life quality and authenticity by the original community leading to social problems.



**Figure 4.18:** *The effects of tourism evaluated for Hoi-An (Author 2017)*

The most prominent positive effects of tourism on Hoi-An is the creation of additional recreational facilities for both tourists and locals, as well as the development of infrastructure around the historic town centre (see Figure 4.5.2). The most prominent negative effects are a possible feeling of alienation by the original community leading to a loss of their life quality; and the degradation of historic structure through the excessive use of tourists.

## 4.6 HERITAGE PRECEDENT 1: HEDMARK MUSEUM/ STORHAMAR BARN, HAMAR, NORWAY

Architect: Sverre Fehn

Project year: 1979

### Approach to alteration:

Sverre Fehn's interventional design of the Hedmark Museum, also referred to as the Storhamar Barn, in Hamar, Norway in 1979 is similar in approach to the work of Carlo Scarpa who allowed his design to be led by discoveries on site (Scott 2008:211). For the Hedmark Museum intervention, the historic fabric of a barn was altered to house a museum exhibition. Elevated views were created with a new concrete ramp that becomes the entrance to the building and hovers over the existing structure (see Figure 4.20). Through these elevated views, one can gain a bird's eye perspective on the archaeological site. The decay of materials over time and the archaeological dig is exposed (see Figure 4.21), and the artefacts discovered placed on exhibition, as presented in Figure 4.23 (CMU Architecture Scandinavia 2010). Each artefact and its story was carefully studied before creating unique display cases.

Fehn used four new materials in the intervention, namely off-shutter concrete, clear glass, laminated wood and black powder coated steel (see Figures 4.19 and 4.23). The choice of new materials succeeds in giving the alteration longevity and permanence, and although the new compliments the old, a contrast in textures is visible. The structure

is flooded with natural light, placing the building and materials on display together with the archaeological artefacts. The alteration contributes to the "ruin" or the concept of "perfect incompleteness" as outlined by Scott (2008:213), allowing for future interventions.

### The relevance of this heritage precedent to this study's research question is in its:

- Insertion of a new function into heritage fabric; and
- Creation of a museum exhibition space.

Figure 4.19: Exhibition area (Architecture Norway 2009)

Figure 4.20: New concrete interior walkway (Divisare 2016)

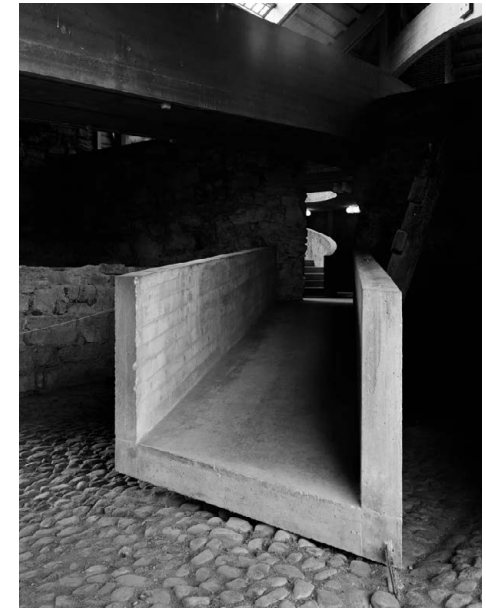
Figure 4.21: Interior walkway (Architecture Norway 2009)

Figure 4.22: New windows (Architecture Norway 2009)

Figure 4.23: Display of artefacts (CMU Architecture Scandinavia 2010)



4.19



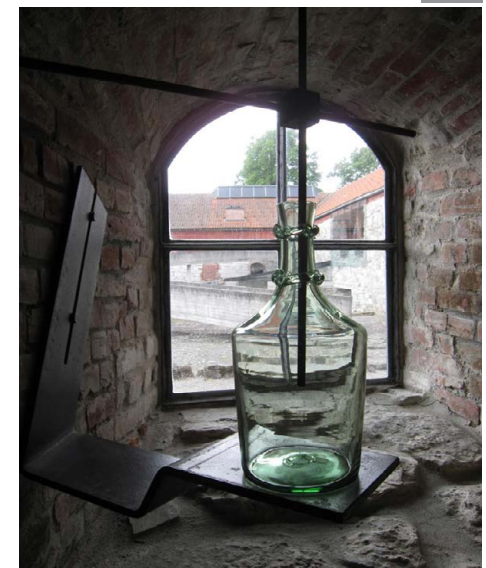
4.20



4.21



4.22



4.23

## 4.7 HERITAGE PRECEDENT 2: NEUES MUSEUM, BERLIN, GERMANY

**Architect:** David Chipperfield Architects in collaboration with Julian Harrap

**Project year:** 1997 - 2009

### **Approach to alteration:**

The Neues Museum in Berlin is an example of heritage alteration with the objective of introducing a contemporary function. The detached parts of the building were united to create a continuous structure that incorporates nearly all the available damaged fabric, while also allowing a series of contemporary elements to be added, as can be seen in Figures 4.24 and 4.25 (David Chipperfield Architects n.d.). The spatiality and materiality of the original structure is emphasised, and the new reflects the lost without imitation (see Figure 4.26).

The architect(s) states that the guidelines from the Venice Charter were followed, thereby respecting the historical structure in its different states of preservation (David Chipperfield Architects n.d.). The Venice Charter, dating from 1964, consists of guidelines for conserving and restoring monuments and heritage sites (ICOMOS 1965). A multidisciplinary interactional approach was undertaken between repairing, conserving, restoring and recreating the components of this now museum. The new main staircase repeats the formal idea of the original staircase, but is implemented as an interpretation, rather than a

replica. The incompleteness of its decorative pattern helps to create a holistic understanding of the historic and contemporary structure, as well as its original and current purpose (David Chipperfield Architects n.d.). The new material palette is simple and modest, complimenting the old, with the main materials being white concrete and sandblasted glass.

### **The relevance of this heritage precedent to this study's research question is in its:**

- Adaptive reuse and restoration of a historic ruin; and
- Creation of a museum exhibition space.

### **Critique:**

The user's navigation through the exhibition might be difficult due to the uniformity of materiality of the spaces. When addressing the visitor's movement in the NZASM Tourist Precinct, care will be taken to design legible spaces for easy accessibility. The differentiation and interface between old and new materiality will also be used to improve legibility.

**Figure 4.24:** A view of the interior circulation space (Archdaily 2011)

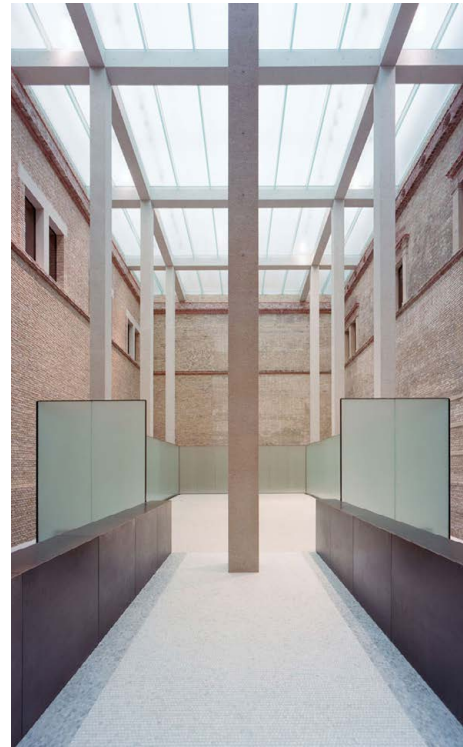
**Figure 4.25:** Views of the interior exhibition space (Kardorff)

**Figure 4.26:** New concrete set against an original brick wall (Archdaily 2011)

**Figure 4.27:** Views of the interior exhibition space (Archdaily 2011)



4.24



4.25



4.26



4.27

## 4.8 HERITAGE PRECEDENT 3: GEHRY HOUSE, SANTA MONICA, CALIFORNIA, USA

**Architect:** Frank O. Gehry

**Project year:** 1978 -1979,

**Further alterations:** 1991

### **Approach to alteration:**

The approach to alteration of a historical house is also analysed as precedent to relate directly to the domestic setting in which the study is rooted. The approach selected is that of Frank O. Gehry's alteration of his own house in 1978 in Santa Monica, California. A Dutch colonial house originating from 1920 was altered to become a contemporary residence for him and his family (see Figures 4.28, 4.29 and 4.31). His approach to alteration consisted of wrapping the old fabric in the new in complete contrast, to create a 'house-within-a-house' (Architect Magazine 2012). Gehry refers to it as "...a balance of fragment and whole, raw and refined, new and old...." (Archdaily 2010). The new fabric embodies an industrial aesthetic, and experimentation took place with known materials, namely chain link fencing and plywood. The integration of materials was inspired by the artist Robert Rauschenberg's collages (see Figure 4.30). The interior was stripped in places to expose structure, and repaired with both old and new fabric.

Critics classify the house as an early work of Deconstructivism (Architect Magazine 2012). The house appears to be permanently under construc-

tion, or the 'perfect incomplete', as per Scott's (2008:212) aforementioned concept of ruination. Gehry states: "...a structure in process is always more poetic than a finished work" (Architect Magazine 2012).

### **Relevance to my research question:**

- Alteration of an existing Dutch colonial house originating from 1920 to become a contemporary residence. The precedent presents an approach to the alteration of a heritage structure similar in design to the NZASM houses.

### **Critique:**

The only relationship between old and new is the extreme contrast. The alterations undertaken in the NZASM Tourist Precinct will attempt to find a middle way in approach between a contrast and copy.

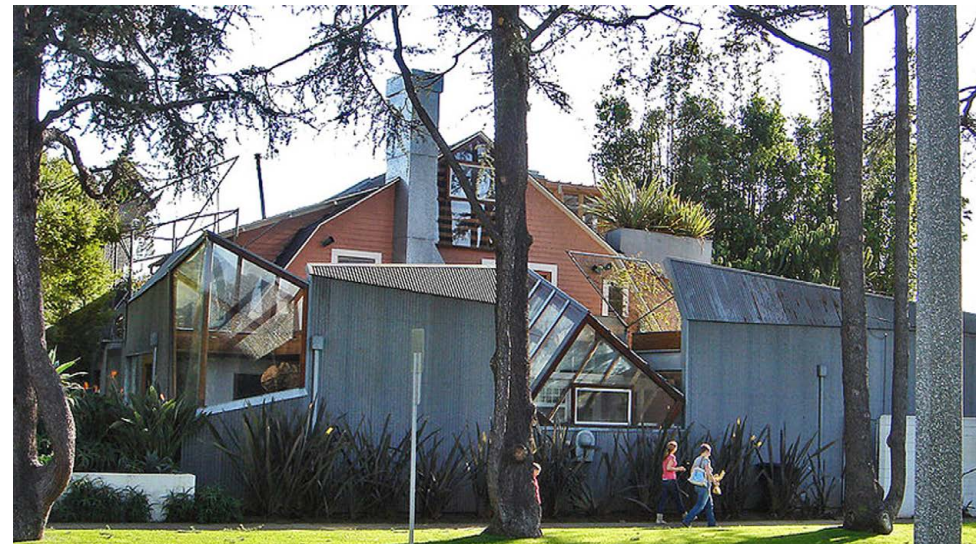
The form is difficult to understand, and not very legible to the public. This is not a problem as long as the structure functions as a private residence. In the case of the NZASM tourist precinct the site's function will be altered from domestic to include public functions, making legibility of form very important for public accessibility.

**Figure 4.28:** Street facing exterior view (Architravel 2015)

**Figure 4.29:** Kitchen interior (Archdaily 2010)

**Figure 4.30:** Horsefeathers Thirteen-VII, 1976, Robert Rauschenberg (Artsy 2017)

**Figure 4.31:** Street facing hand-drawn elevation (Archdaily 2010)



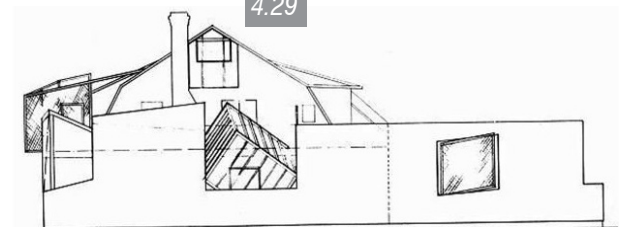
4.28



4.29



4.30



4.31

## 4.9 TOURISM AS PROGRAMME PRECEDENT 1: VISITOR CENTRE EMSCHER VILLAGE, OBERHAUSEN, GERMANY

Architect: Ooze Architects

Area: 1263 sqm

Project year: 2014

### Programmatic explanation:

The temporary visitors centre has been created from reclaimed containers housing different functions (see Diagram 4.32). The focus is on creating a route through a village, and on the in-between spaces, sheltered by a roof or in the open air. Different activities and social spaces are plugged in along the route, as can be seen in Figure 4.33 (Archdaily 2014).

The journey through this village and the sequence of activities go from renting a bike; encountering an information office (see Figure 4.35), cafés, shops, and a cinema; and ending in an artist village with art production and education (see Figure 4.34) (Archdaily 2014).

The path is defined by different material qualities (see Figure 4.36). For example, the route uses pallets, pebbles and grass. The textile roof structure creates sheltered spaces and offers a spatial chromatic experience (Archdaily 2014).

### The relevance of this tourism as programme to this study's research question is in its:

- Function as a tourist village, with plug-in

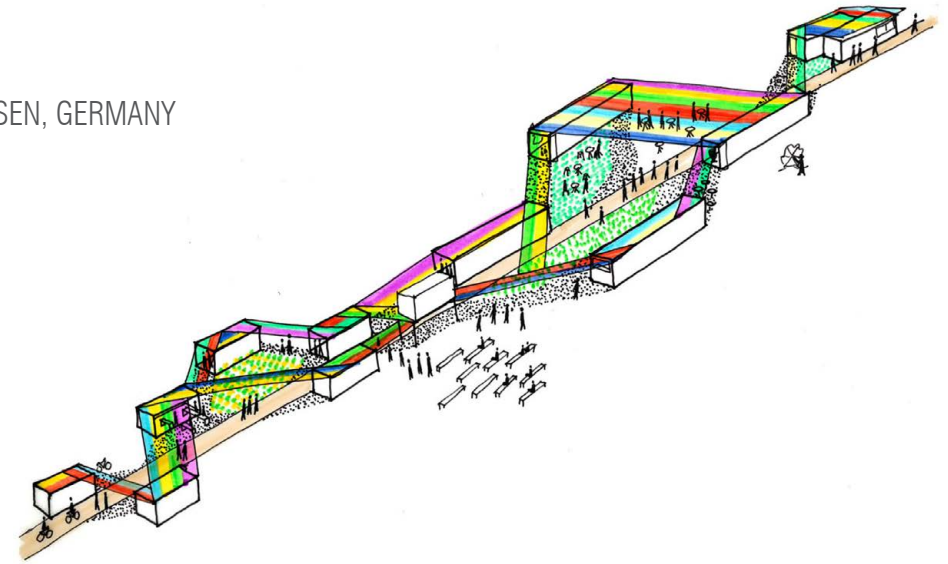
functions, for example information office, cafés, shops, and a cinema.

### Successful implementation:

- Legible visual language through a single binding element;
- Clear directional movement; and
- Economical use of temporary materials.

### Critique:

- Limited space and height in containers;
- Uniform use of material in information centre creates bland appearance.



4.33

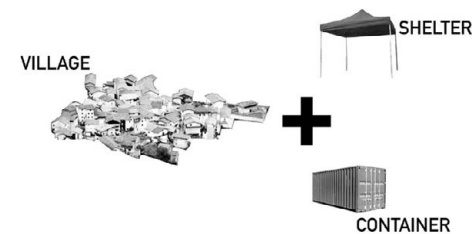
Figure 4.32: Concept diagram (ArchDaily 2014)

Figure 4.33: Axonometric concept diagram (ArchDaily 2014)

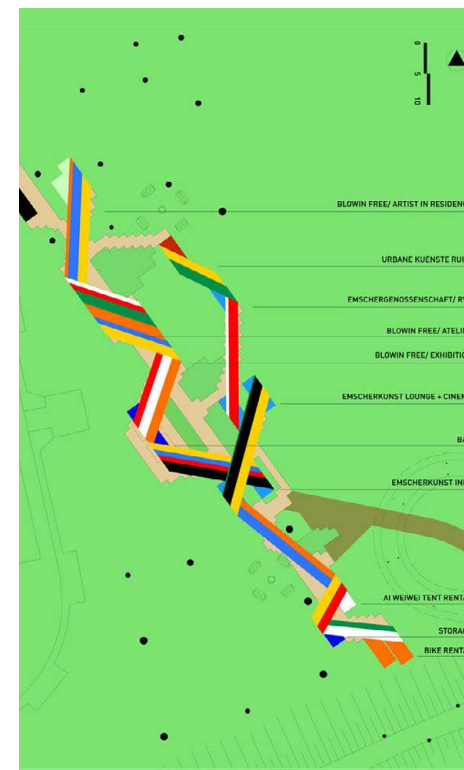
Figure 4.34: Map of amenities (ArchDaily 2014)

Figure 4.35: Interior view of information centre (ArchDaily 2014)

Figure 4.36: Exterior view of temporary structures (ArchDaily 2014)



4.32



4.34



4.35



4.36

#### 4.10 TOURISM AS PROGRAMME PRECEDENT 2: VILAKAZI STREET PRECINCT, SOWETO, SOUTH AFRICA



4.37



4.38

##### Programmatic explanation:

Vilakazi Street is the only street to have housed two Nobel Prize winners in the world. It is home to the Mandela House museum (see Figure 4.37), as well as the house where Archbishop Desmond Tutu once lived. The street is a popular precinct for local and international visitors, complete with restaurants, interactive public artworks and a variety of curio stalls (see Figure 4.38). The street has been renovated to become a tourist-friendly area, with a pedestrian walkway, benches and trees (Brand South Africa 2010).

The Vilakazi Street precinct is about a kilometre long, in the shape of a triangle. At number 8115 one can find the street's main attraction – the Mandela House Museum. The simple three-bedroomed home (see Figure 4.39) has been restored to what it looked like in 1946, when Nelson Mandela first moved in (Brand South Africa 2010). There are also numerous other Soweto tours accessible from Vilakazi Street, including attractions like the Hector Pieterse Museum, Apartheid Museum and the Orlando Towers.

##### The relevance of this tourism as programme to this study's research question is in its:

- Function as a tourist precinct with various attractions; and
- Insertion of new function into heritage fabric, for example the Mandela House museum.

##### Successful implementation:

- Attention is drawn to the area through the use of colour and art, which has allowed the street to develop a new identity.
- The streetscape is activated as a recreational zone.
- Attractions and amenities are linked through the use of visual elements and paths.
- Dedicated parking zones ensure a mainly pedestrian street.

Figure 4.37: The view of the Mandela House in Vilakazi street (Gauteng 2017)

Figure 4.38: View of Vilakazi Street (Mapio)

Figure 4.39: Type C2 House plan, dated 1944 (Joburg 2008)



4.39

## 4.11 TOURISM AS PROGRAMME PRECEDENT 3: TOURIST HOUSE, TARDETS-SORHOLUS, FRANCE

Architect: V2S architectes

Area: 400 sqm

Project year: 2015

### Programmatic explanation:

As a method of developing tourism, a significant historical house in the middle of the village square has been transformed into a tourist centre for the Soule Valley (see Figures 4.40 and 4.41). Like all the houses in the centre, one façade opens up to the square and the other into a garden.

Open plan interior spaces (see Figures 4.42 to 4.43) have been created to make the most of the light from both the street side and the garden side. A large display unit runs along the entire length of the house. Storage is incorporated underneath. The unit becomes the reception desk, as well as a partition to a closed-off private area for staff. The heritage of the house is celebrated by exposing all the existing beams and joists. Lighting and ventilation systems are also on show and painted in the same colour as the walls (Archdaily 2016).

### The relevance of this tourism as programme to this study's research question is in its:

- Inclusion of a tourist information centre and exhibition space; and
- Insertion of new function into heritage fabric.

### Successful implementation:

- Contrast in textures between old and new;
- Opening internal spaces to allow flow of light and viewpoints; and
- Linking spaces with the use of one main material.

### Critique:

- The temporary stance was taken to the interior furniture and elements, and the link to the heritage fabric is not clear;
- Design features, for example the suspended recreational net, and pink and blue coloured lights are not timeless; and
- Minimal alteration of the street-facing façade makes the centre difficult to recognise.

Figure 4.40: Exterior entrance view (ArchDaily 2016).

Figure 4.41: Main entrance (ArchDaily 2016).

Figure 4.42: Exhibition space (ArchDaily 2016).

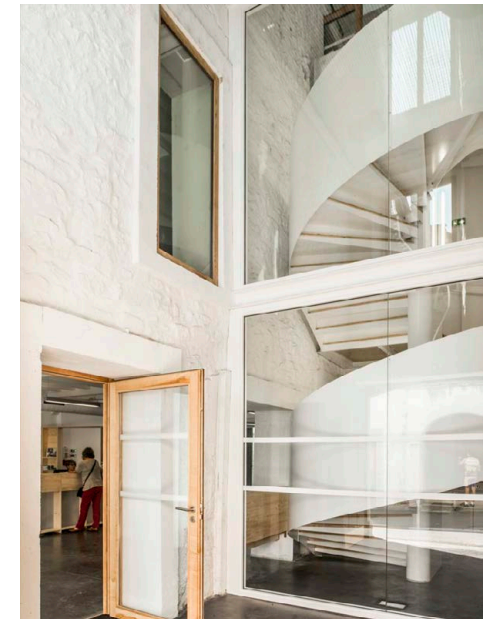
Figure 4.43: Interior views of the information centre with a new seat built into an existing opening (ArchDaily 2016).



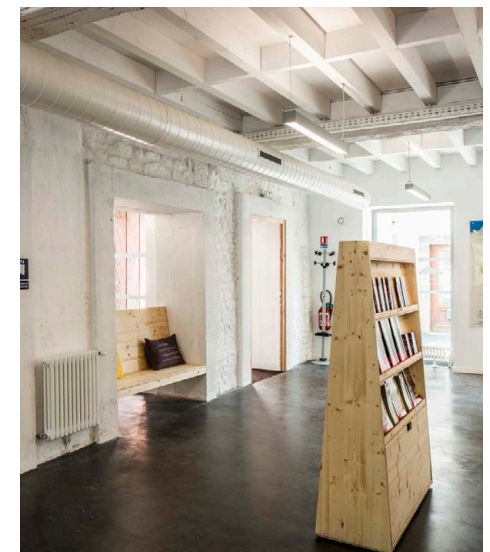
4.40



4.42



4.41



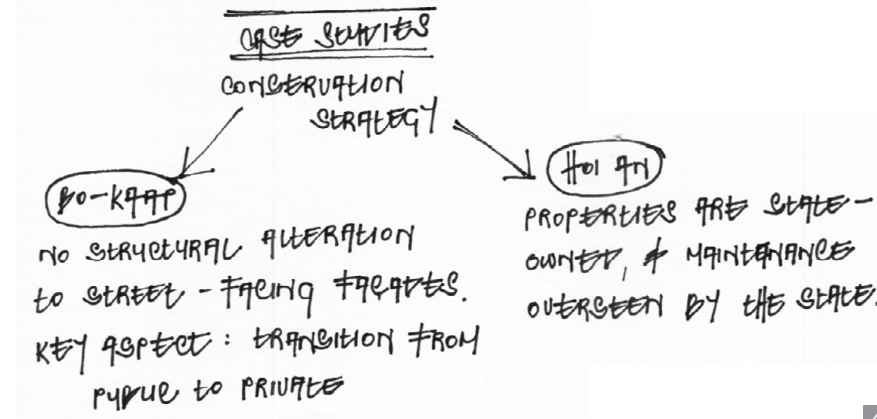
4.43



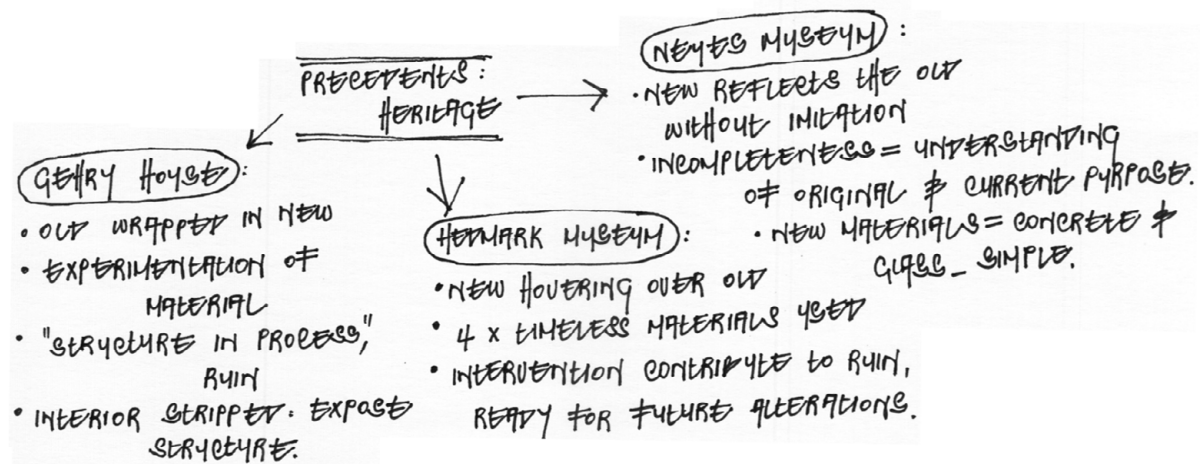
## 4.12 CONCLUSION

The investigation of case studies and precedents presented in this chapter assists in providing guidelines for how conservation and alteration is dealt with in other historical interventions. Through the review of the case studies it was found that a general conservation strategy serves to protect the heritage fabric in both the Bo-Kaap and Hôi An (refer back to Figures 4.17 and 4.18, as well as Diagram 4.1 here). These state-driven strategies do not, however, address the requirement of the occupants on a day-to-day or detailed level. When working with heritage fabric, the condition and value of each case should be assessed and a site-specific strategy should be put into place, with the collaboration of the resident community.

The heritage precedents presented in this chapter show approaches to alteration employed by different interventionists (see Diagram 4.2). The strategies followed by Fehn and Chipperfield are sensitive towards the host building and allow their decisions regarding the new be informed by the old. Gehry's alteration of his own house is, in contrast, a bold narrative consisting of the experimentation of materials and construction. Tourism as programme is a successful means of uplifting an area and community. Using elements from these examples in the proposed NZASM project will assist in ensuring this intervention's success.



4.1



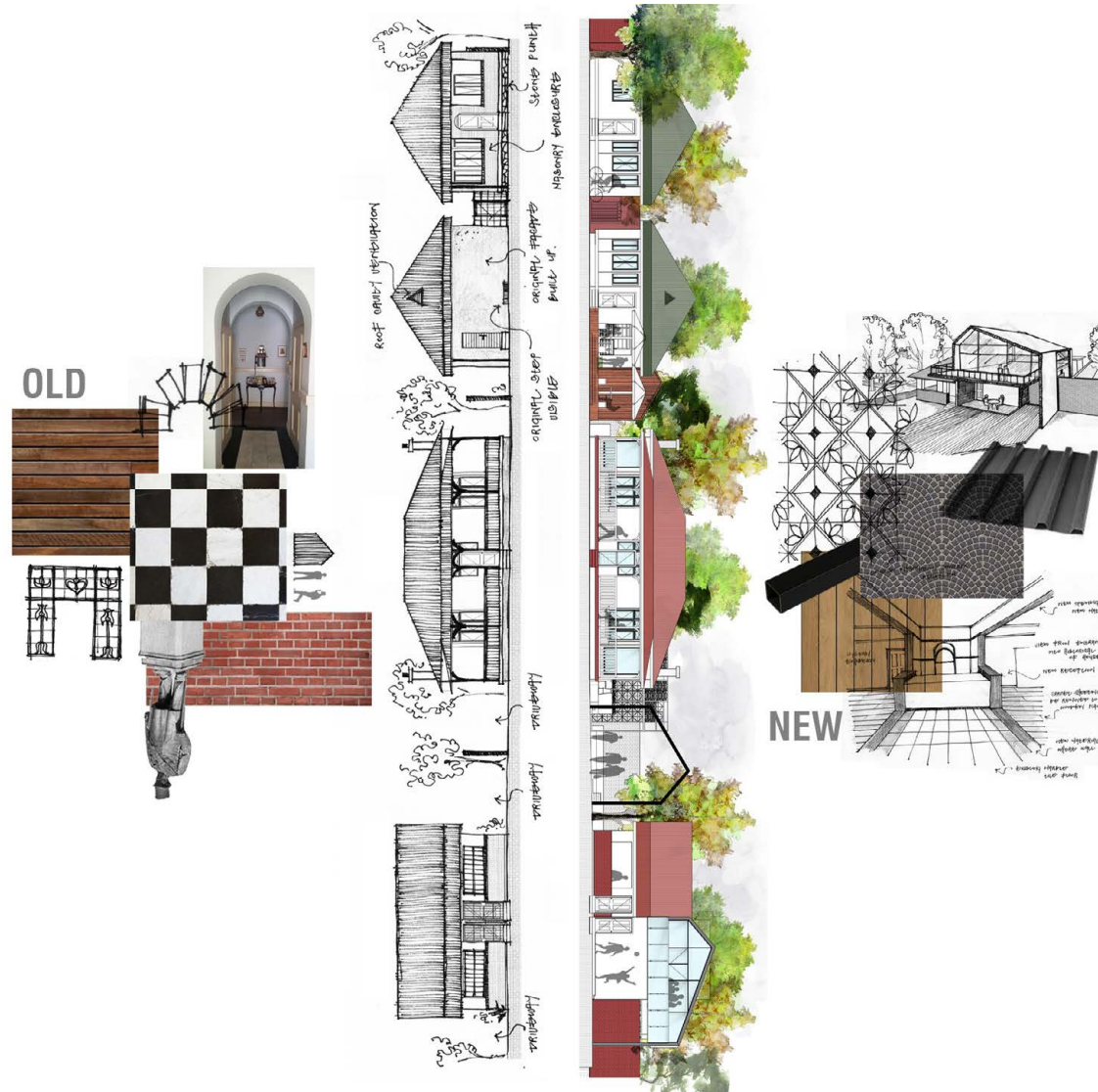
4.2

**Diagram 4.1:** Summary of case study conservation strategies (Author 2017)

**Diagram 4.2:** Summary of heritage precedents (Author 2017)



# CHAPTER 5: DESIGN AND TECHNICAL DEVELOPMENT





## 5.1 INTRODUCTION

After concluding the context study, theory investigation and analysis of case studies and precedents, guidelines were generated to inform the design. These guidelines are discussed in detail in this chapter. Chapter 5 is structured in three parts: Part 1 consists of a summary of the key design informants. Part 2 is concerned with the conceptual approach and design development, namely the urban vision for the site, the strategy for the social and natural landscape and the material palette consisting of new and existing finishes. The existing architectural detail and ornamentation which are abstracted to create new design motifs is also discussed here, as is the final design. Part 2 ends with an illustration of the initial plans and models.

Technical development and resolution are dealt with in Part 3. The main technical problem and sub-problems are identified. Thereafter, a technical approach based on Chapters 2 to 4 and technical precedents are outlined. A system of criteria for testing and iteration of the technical resolution is explained.

**Detail resolution in Part 3 addresses the following design interventions:**

- Architectural additions to a youth hostel;
- Accessible entrance to the youth hostel and tourist centre;
- Interior intervention in 19 Tulleken Street consisting of a tourist information and exhibition centre; and
- Addition of a tuckshop to 21 Tulleken Street.

**Figure 5.1 Chapter cover page:** *Conceptual collage of the old as opposed to the new (Author 2017)*

# PART 1: DESIGN INFORMANTS

## 5.1.1. CONTEXT AS INFORMANT

Through the documentation and analysis of 15 and 17 Tulleken Street, 19 Tulleken Street, 21 and 23 Tulleken Street (please refer back to Sections 2.1.6 to 2.1.8 in Chapter 2), precious heritage fabric has been identified. The criteria include fabric that is true to the era from which it dates, original to the structure and possess a certain rarity. Elements such as the floor finishes, columns and arches, fireplaces, windows and roofs were analysed in terms of form and pattern. These were then abstracted and reinterpreted to create design motifs for the design intervention.

An interplay between organic shapes and patterns found in the floral motifs in the stained-glass windows (see Figure 5.1.1) and arches (see Figure 5.1.2), exist together, with regular grids and angular shapes found in the roofs (see Figure 5.1.4) and floor finishes (see Figure 5.1.5). A rounded arch shape is common in most of the houses in the doorways, as well as in the decorative pattern on fireplaces (see Figure 5.1.3). Diagrams 5.1.1 and 5.1.2 provide visual summaries of these kinds of design informants.

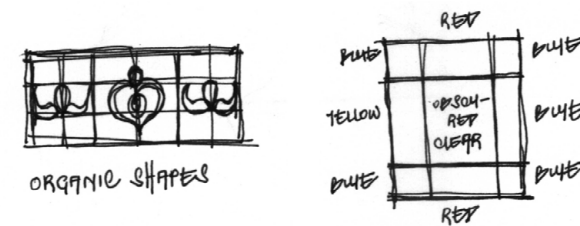


Figure 5.1.1: Stained glass windows in wooden frames (Author 2017)

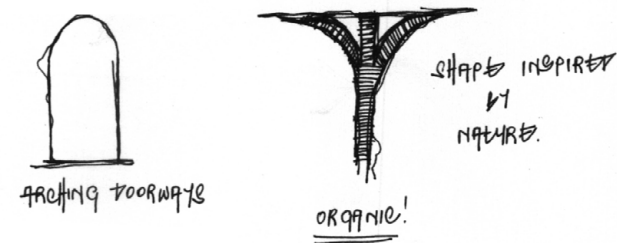


Figure 5.1.2: Arched doorways and columns (Author 2017)

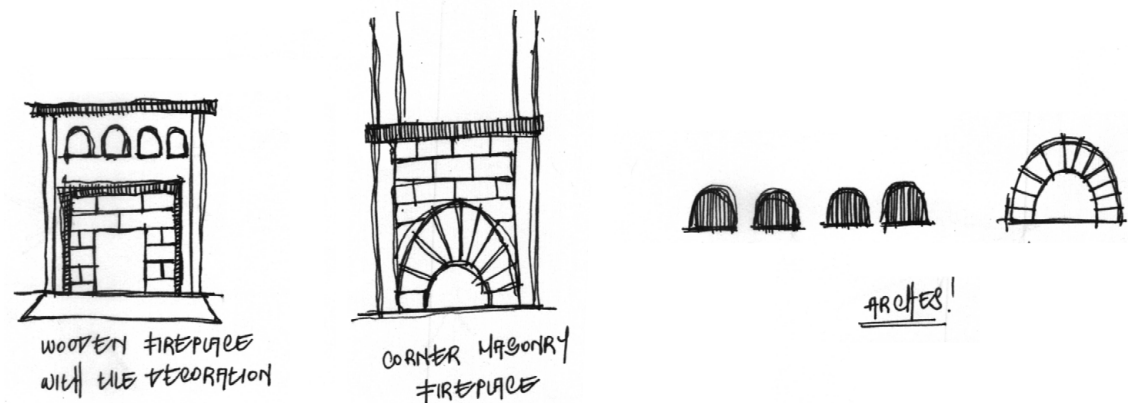


Figure 5.1.3: Wooden and masonry built-in fireplaces (Author 2017)



Figure 5.1.4: Pitched sheet metal roofs (Author 2017)

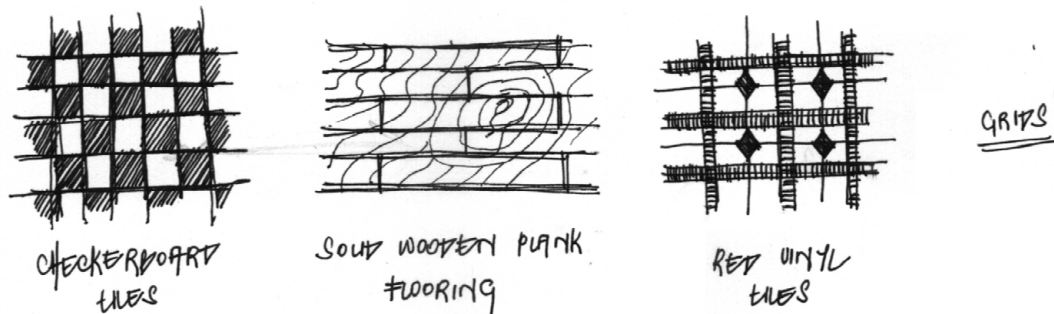


Figure 5.1.5: Floor finishes (Author 2017)

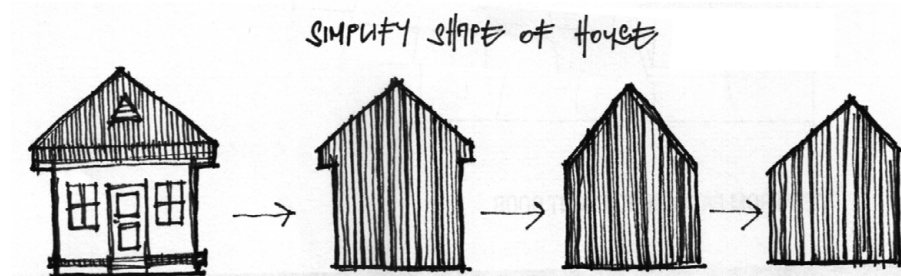


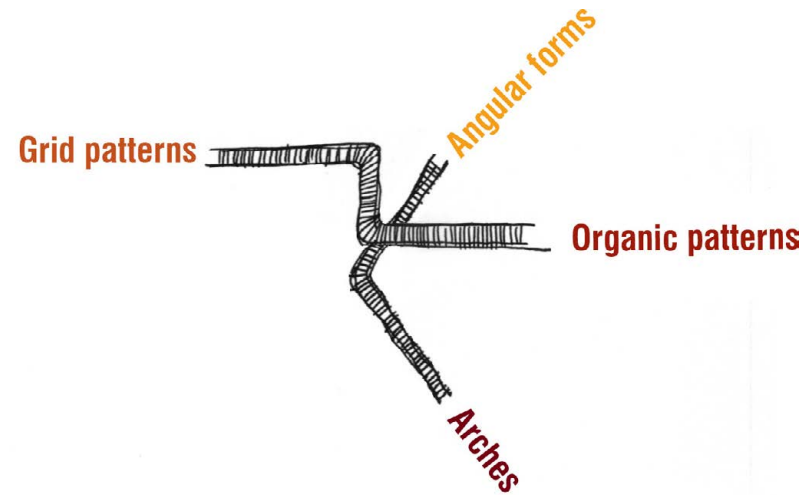
Figure 5.1.6: The shape of a traditional house is simplified (Author 2017)

**The main heritage features are:**

- An ornate veranda with decorative wooden columns and balustrade;
- Stained glass in wooden frame windows;
- A wooden fireplace with wooden inlays, metal and tile decoration/a corner masonry fireplace;
- Solid wooden plank flooring;
- Marble or other natural stone tiles;
- Original brass light switches that are no longer functional;
- Pressed metal ceilings;
- A decorative plaster ventilation brick; and
- A steel triangular roof cavity ventilation louvre.

**Design guidelines as derived from the Statement of Significance (please refer back to Section 2.1.15 in Chapter 2) are as follows:**

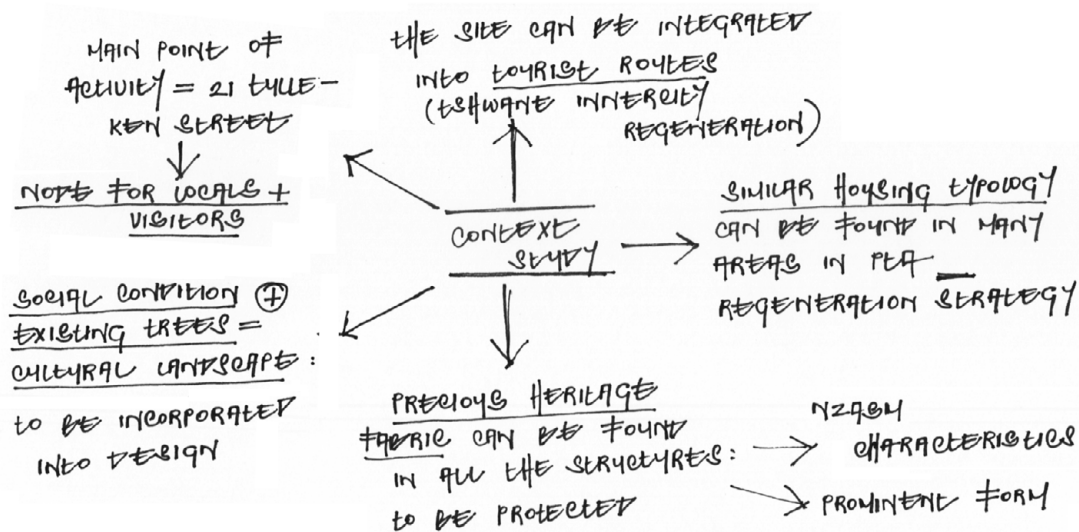
- The aesthetic and heritage features of the site should be conserved and maintained. Restoration and preservation to take place as required;
- Built fabric that does not contribute to the heritage value of the structure should be stripped away where necessary so as to expose and celebrate heritage features;
- The structures are informative regarding Pretoria's historical context and can play the role in the public realm of educating users; and
- The cultural landscape, consisting of the social conditions and trees, should be conserved and maintained.



5.1.1

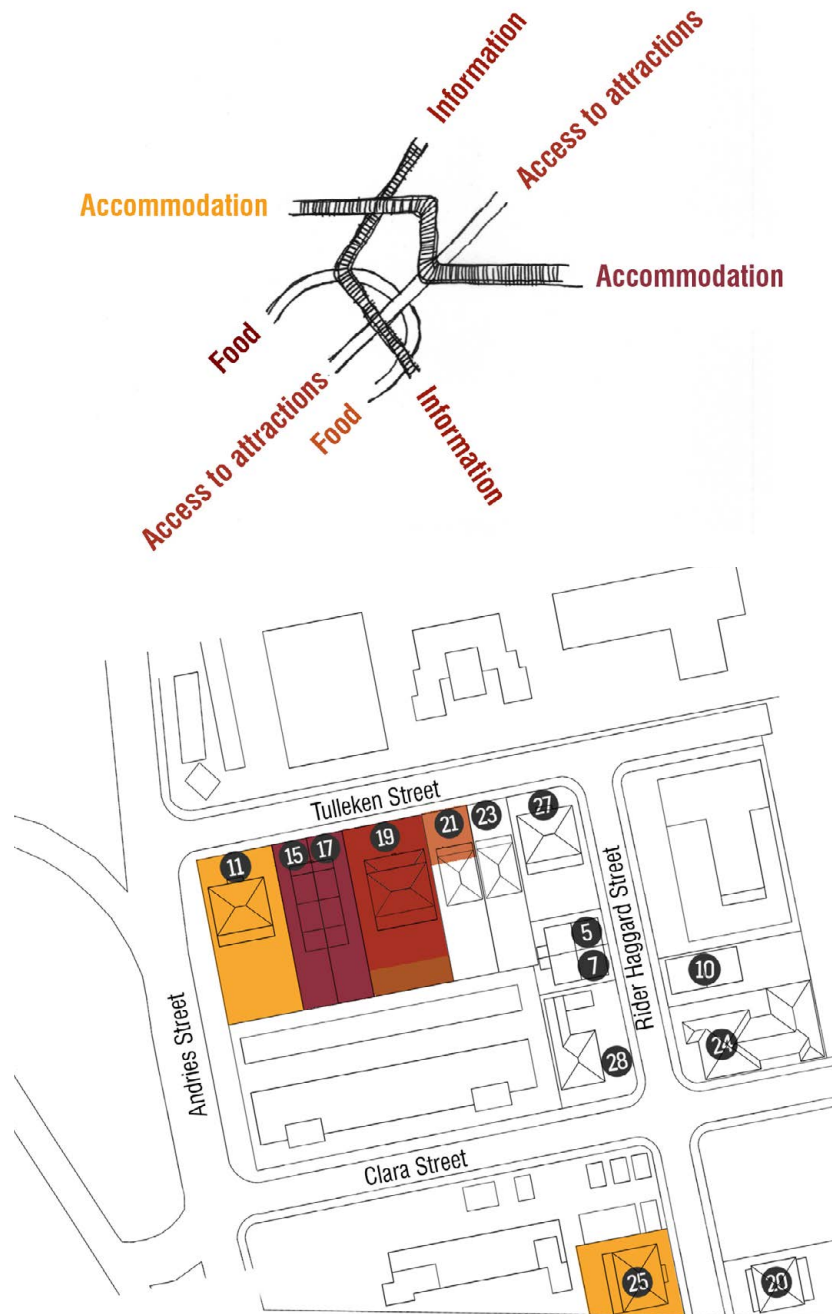
**Diagram 5.1.1:** Summary of form extracted from analysis in Figure 5.1.1 - 5.1.6 (Author 2017)

**Diagram 5.1.2:** Summary of informants from the context study (Author 2017)



5.1.2





5.1.3

### 5.1.2 PROGRAMME AS INFORMANT

Tourism as function has been given relevance through an analysis of the proximity of public transport and tourist attractions, and a critical analysis of the closest tourist information office at Church Square (please refer back to Section 2.2.2 in Chapter 2). Tourists will visit the area for a variety of reasons. Some may come as day visitors and for the heritage experience; others for the restaurants and/or events; while still others may come to stay for a short period, be it overnight or for several nights.

The main functional requirements of a tourist precinct are the availability of information, food and beverages, accommodation and access to the next attraction (see Diagram 5.1.3).

According to these requirements, specific houses have been identified for adaptive reuse and will function as a youth hostel, tourist centre, information office, NZASM exhibition space, curio shop and restaurant respectively. A tuckshop with take-aways and several Airbnb's will also form part of the tourist precinct (see Figure 5.1.7). These functions are supplemented with a variety of outdoor nodes and recreational spaces for tourists and the community.

- Tourist specific functional layout:
- 11 Tulleken Street: Airbnb
  - 15 & 17 Tulleken Street: Youth Hostel
  - 19 Tulleken Street: Tourist Information Centre
  - 21 Tulleken Street: Tuckshop
  - 25 Rider Haggard Street: Airbnb

5.1.7

**Diagram 5.1.3:** Functional requirements of a tourist precinct (Author 2017)

**Figure 5.1.7:** Tourist specific functional layout (Author 2017)

### 5.1.3 THEORY AS INFORMANT

To implement tourism as an adaptive reuse of a series of NZASM houses, a sensitive approach to heritage fabric is required. Different approaches can be taken to different fabric of the same structure, leading to a combined strategy to heritage alteration (see Diagram 5.1.4). A statement of significance (please refer back to Section 2.1.19 in Chapter 2), as defined by the Burra Charter (ICOMOS 2013:4), helps to identify between precious heritage fabric and non-precious heritage fabric. Precious heritage fabric can be dealt with by stripping back negative past additions, restoring, reconstructing and preserving the original fabric. Non-precious heritage fabric can be dealt with in a less sensitive manner, with the objective of preparing it to accommodate a new function. Such fabric can be interpreted, stripped back or demolished as necessary in preparation for its new function, and altered as required.

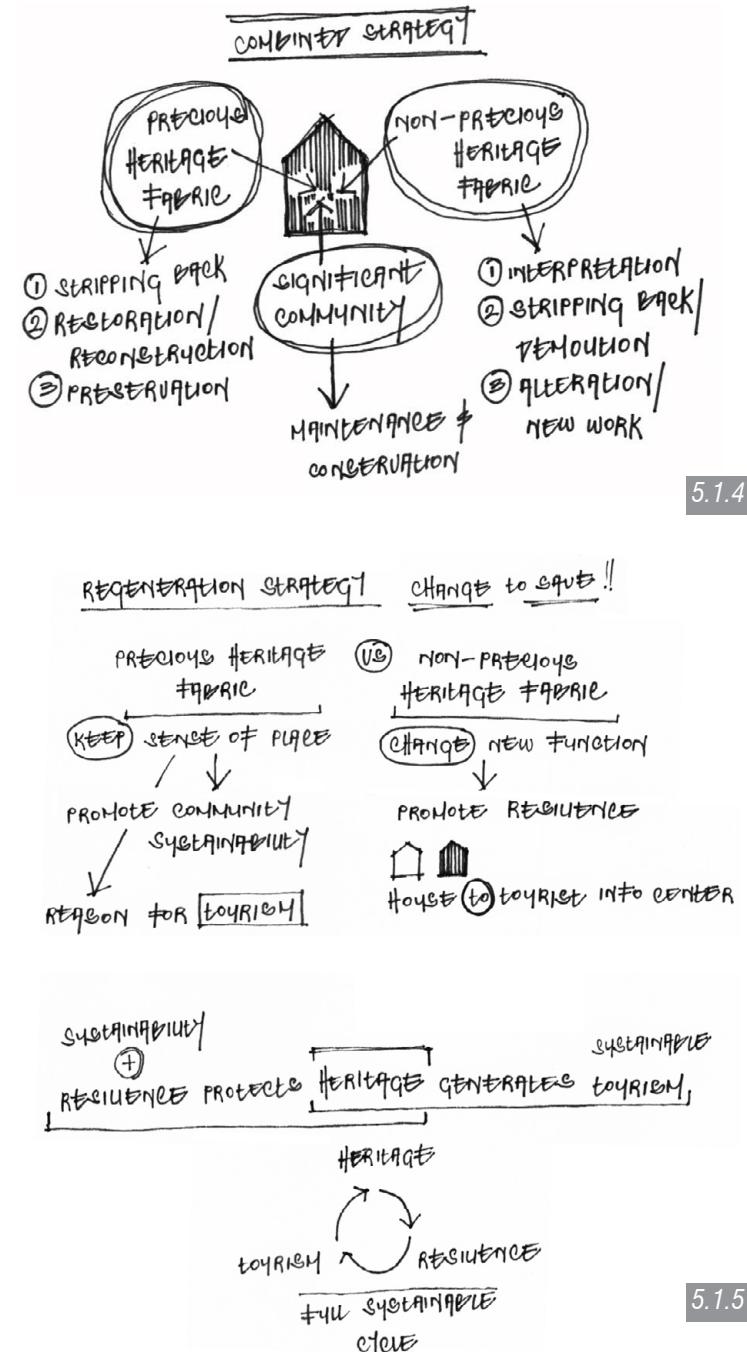
The local community that forms part of the cultural landscape should be involved and integrated into the proposed development. Educating the community regarding the heritage structures in which they reside will increase the protection and sustainability of heritage fabric, and aid in developing a local brand with many job opportunities created through

tourism. The narrative of the NZASM heritage will be extended to include the culture and heritage of new residents, with tourism being the link between the past and present.

A regeneration strategy (see Diagram 5.1.5) is created through the separate approach to precious heritage fabric and non-precious heritage fabric. In other words, the former's authenticity and value creates a sense of place and involvement by the local community, which in turn attracts tourists to the site. The latter can be altered to accommodate a new function, thereby improving the resilience of the site and supporting the sustainability of the precious heritage fabric. A sustainable cycle is thus created whereby precious heritage fabric is preserved and celebrated to draw in tourists, and non-precious heritage fabric is altered to accommodate the functional requirements of a tourist precinct, while simultaneously uplifting the local community.

**Diagram 5.1.4:** A combined strategy to heritage alteration (Author 2017)

**Diagram 5.1.5:** The regeneration strategy (Author 2017)



### 5.1.4 CASE STUDIES AND PRECEDENTS AS INFORMANTS

The following design informants have been established through the case studies:

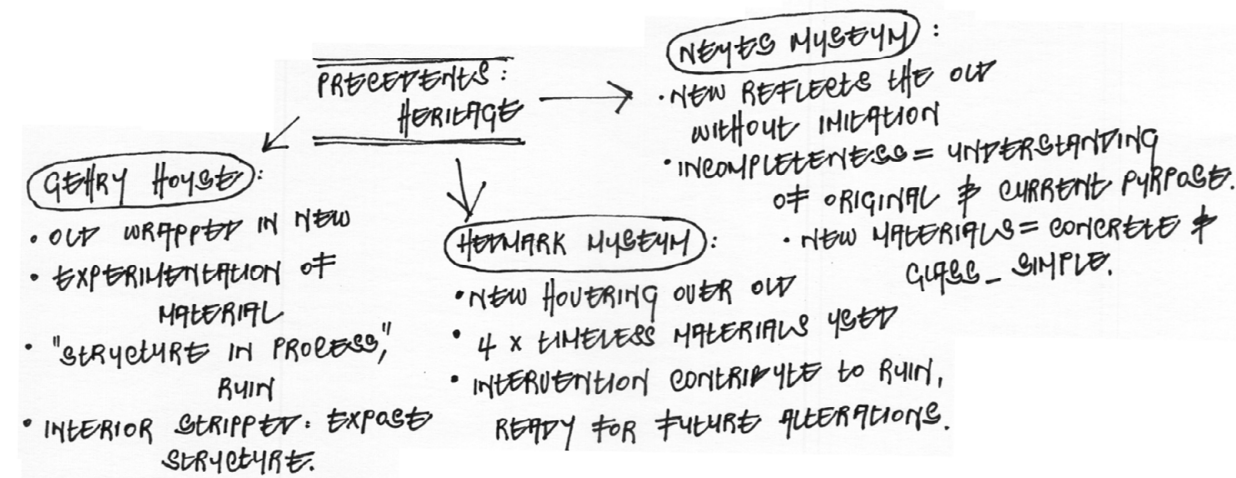
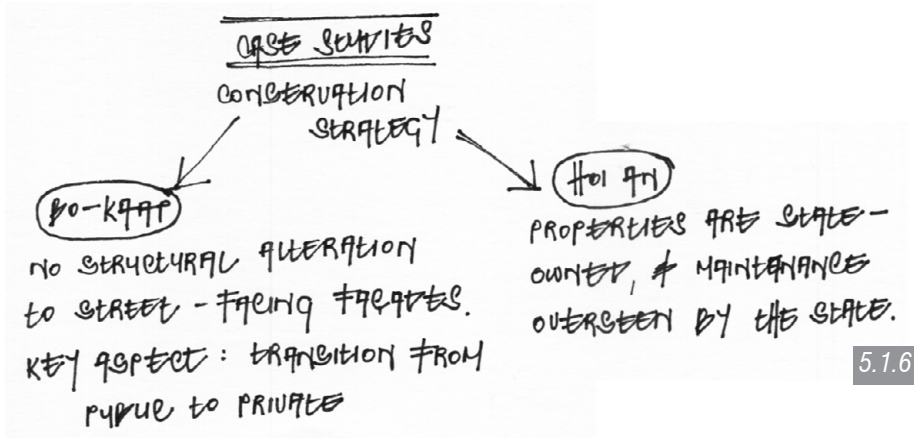
- Although a general conservation strategy can be implemented to protect a group of heritage structures, individual analysis should still be carried out regarding each structure's fabric so as to ensure maximum record and protection.
- The organisation of new functions should inform a visitor of the private or public nature of spaces.

- A sense of ownership needs to be established within the local community to ensure the sustainable management of the new function.
- The creation of employment through this development should be aimed at the local community, who should also have the first opportunity to create their own businesses.

The following informants have been generated through an analysis of the heritage precedents:

- The materiality of the intervention complements the existing fabric;
- The old and new come together to form a unity, but are still recognisable from each other;
- A palette of a maximum of four new materials ensures a simple, timeless intervention, for example steel, concrete, wood and glass; and
- The intervention needs to be incomplete in essence so as to accommodate future alterations and function changes.

Diagram 5.1.6: Summary of case study conservation strategies (Author 2017)  
Diagram 5.1.7: Summary of heritage precedents (Author 2017)



# PART 2: DESIGN DEVELOPMENT

## 5.2.1 CONCEPTUAL APPROACH

An inside out approach is followed. That is, design decisions are made through the 'eyes' of the interior. Precious heritage elements found bedded in the interior fabric are analysed, abstracted, interpreted and synthesised into the interior and exterior alteration. The outcome is to bind the built structures of the tourist precinct together through a single design language.

This single language gives life to the concept of heritage for all, with the intention of bringing heritage fabric into the public realm and community. Valuable heritage hidden within private domestic structures should be shared with the rest of the community and celebrated. Moreover, such heritage serves as an educational tool to the general public and tourists. The façades of the structures will conceptually unfold to facilitate a meeting between interior and exterior, thereby drawing visitors into the structures and nodes.

Existing and new nodes of activity have been identified as pertaining to the interior and exterior of the NZASM houses. These nodes will become pockets where interaction between locals and tourists can take place. For example, the seating deck of the tuckshop will bring different people into contact. A three-dimensional experience is designed around the existing cultural and built

landscape, activating the high boundaries of the site. Infill elements will be used as a place-making device. The physical form of the elements is derived from the silhouette of the houses. The new structures are designed to communicate a lightness and establish a visually recognisable link to bind the newly-created precinct.

Figure 5.2.1 provides sketches at to these various aspects:

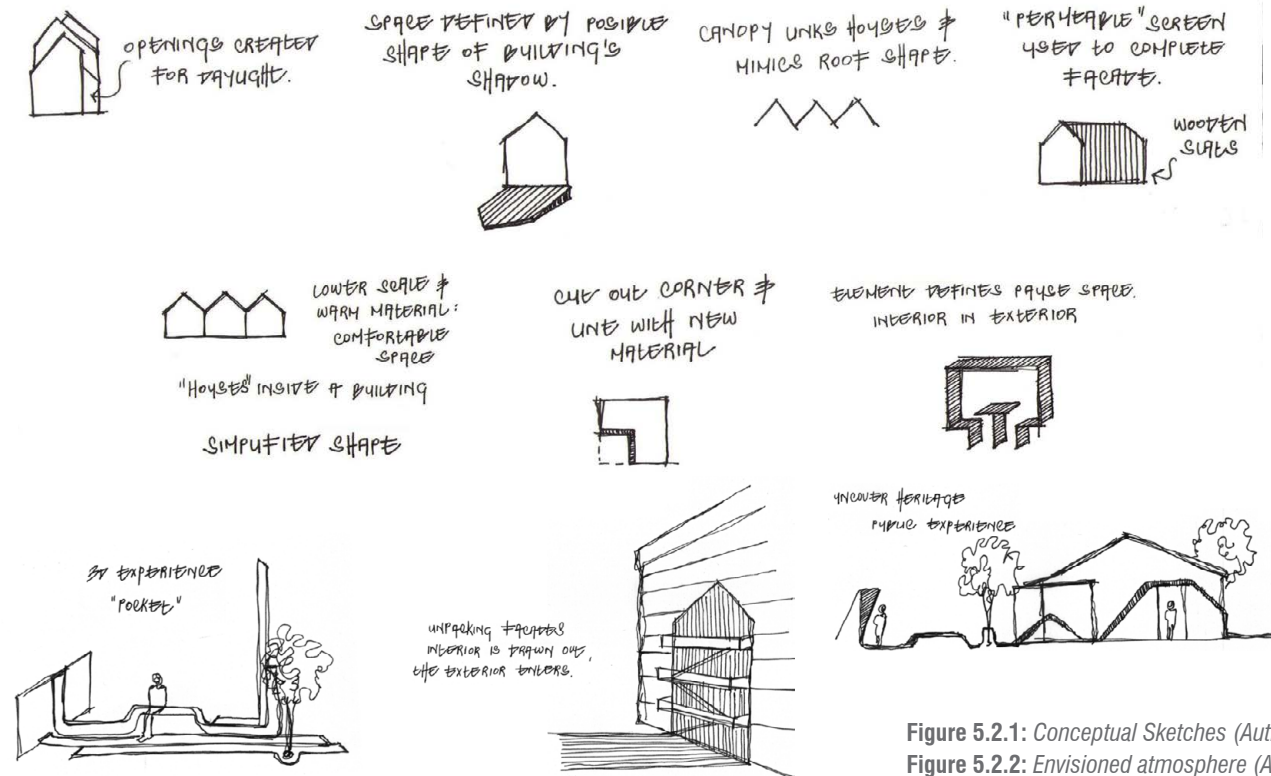


Figure 5.2.1: Conceptual Sketches (Author 2017)  
Figure 5.2.2: Envisioned atmosphere (Author 2017)

- A Inside-out approach:** Interior architecture as inspiration for the architecture and urban design. Design decisions are rooted in an analysis of heritage.
- B Heritage for all:** Precious heritage fabric in private residences is exposed to be accessible in the public realm.
- C Pockets of life:** Existing social, structural and natural conditions is taken into account for the creation of a three-dimensional experience of space.

## 5.2.2 ENVISIONED ATMOSPHERE

The study area's past is rooted in the Paul Kruger Government's drive to establish a railway line to Delgoa Bay in Mozambique at the end of the 19th century (De Jong 1990:53). The establishment of the railway station in Pretoria by the NZASM led to the development of the direct area with housing for railway workers. Shortly afterwards, during the Anglo-Boer War (1899-1902), the company's

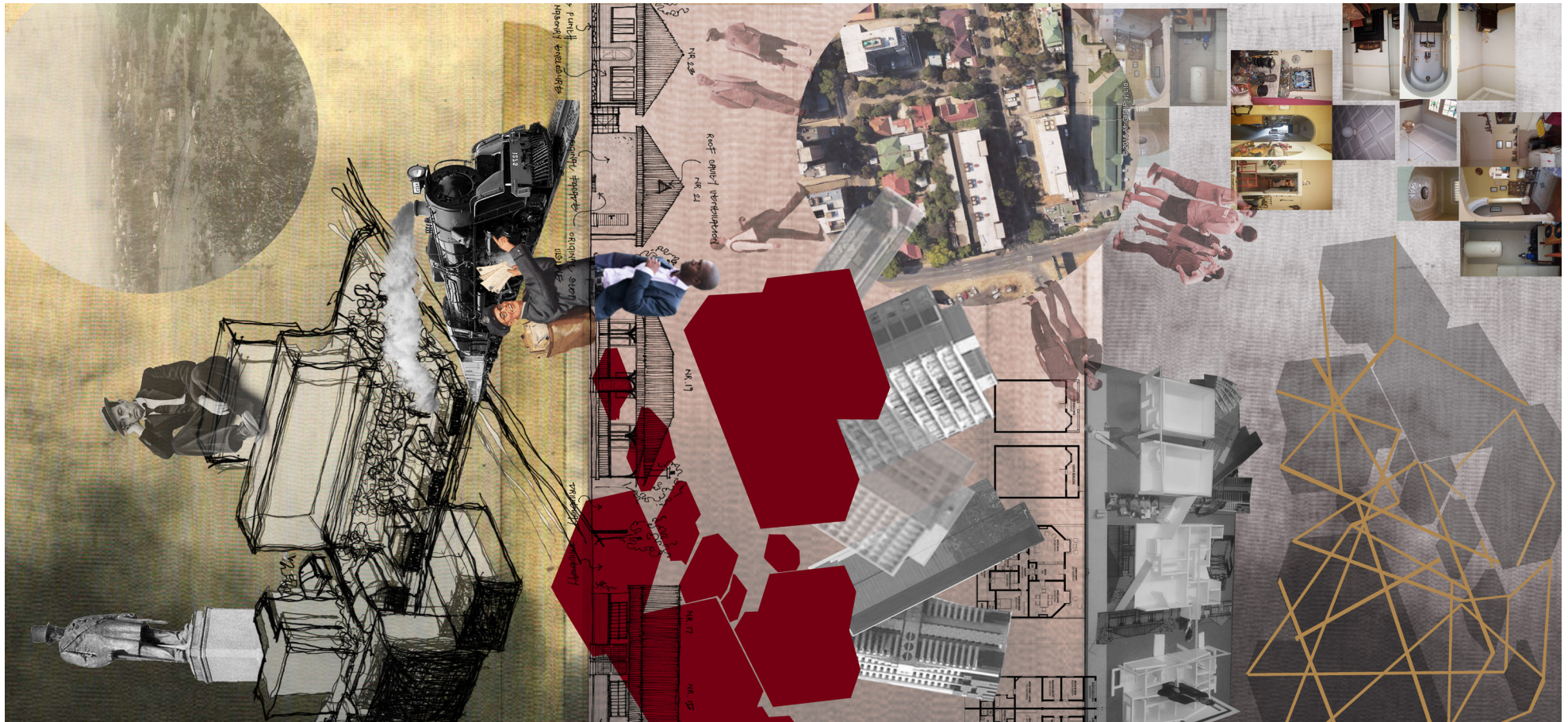
properties were confiscated by British authorities and most of the European personnel for whom the housing was provided were deported (De Jong 1990:53). From then, the area has changed, becoming more diverse over time.

The present conditions on site speak of this diversity in the built structures as well as in the inhabitants. The area has a diverse range of ages

and is culturally rich. There are white Afrikaans speaking people, who have lived in their homes for up to fifty years; local black people; and even people who come from other parts of Africa living in the area. The neighbourly sense of co-habitation serves as an example of a functional multi-cultural South African community.

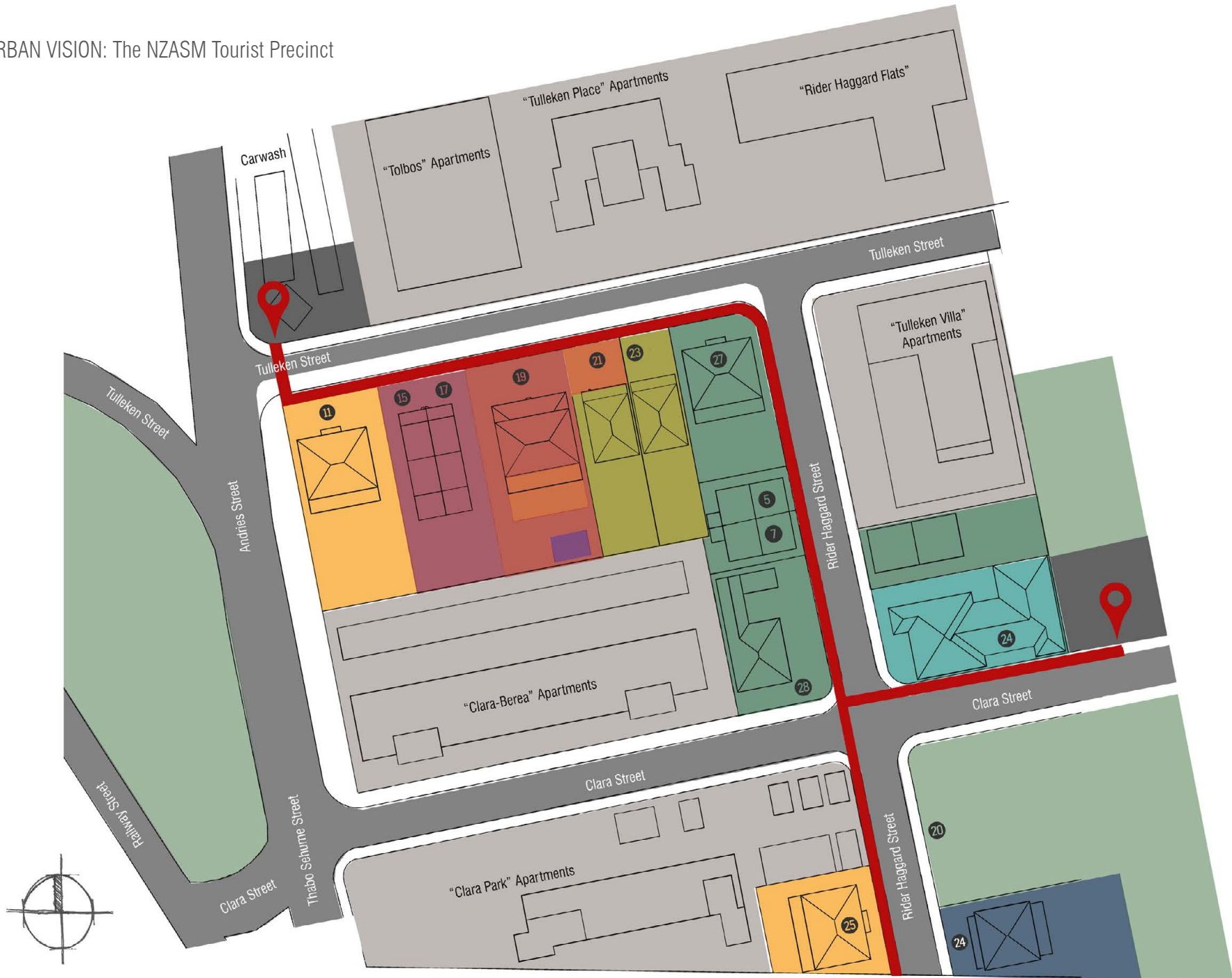
The future of the site lies in the strengthening

of the existing social conditions, combined with the preservation and maintenance of significant heritage fabric, and the subsequent alteration of non-precious heritage fabric through adaptive reuse. Tourism, as the catalyst, will regenerate the heritage fabric, while simultaneously celebrating the cultural diversity of the site and uplifting the local community, as can be seen in Figure 5.2.2.



5.2.2

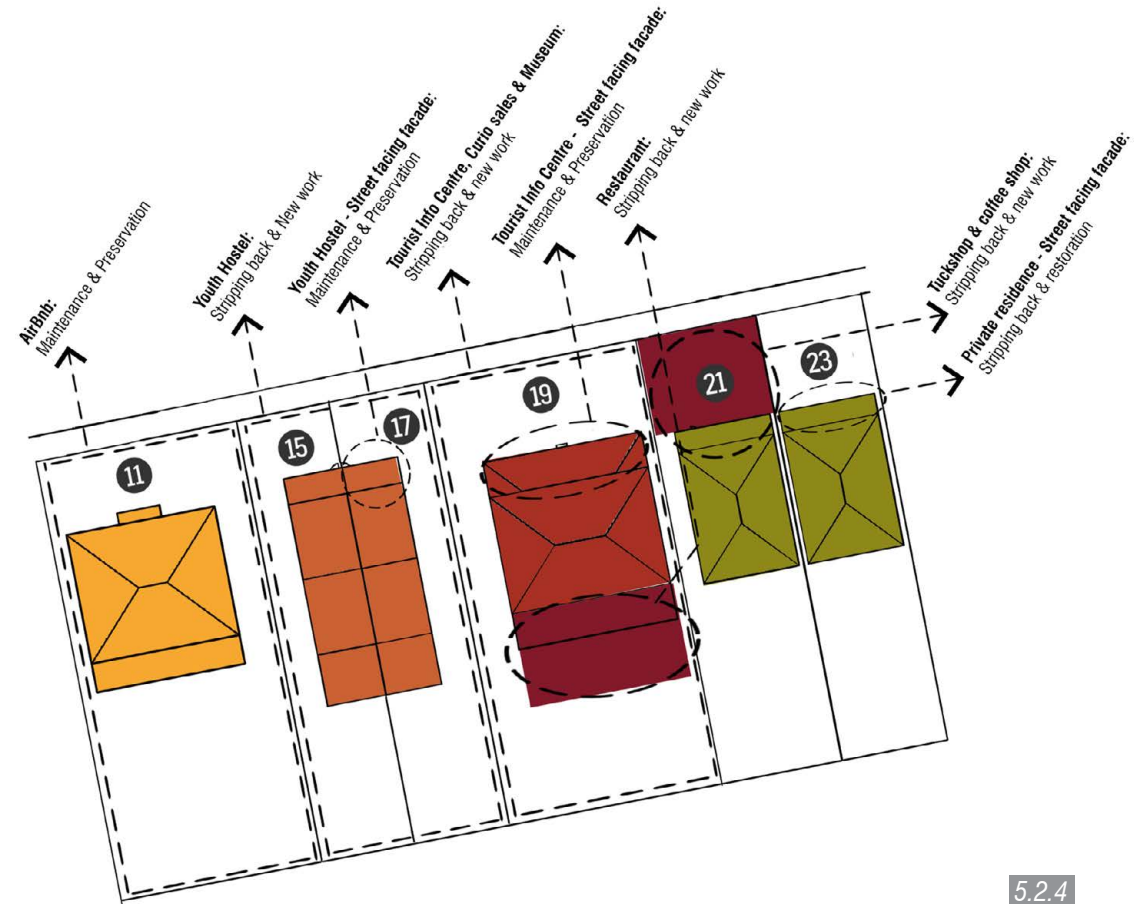
### 5.2.3 URBAN VISION: The NZASM Tourist Precinct



COLOUR KEY:

- Existing: Apartment Blocks  
Proposed: To remain
- Existing: Residential,  
Proposed: Residential with an AirBnB function
- Existing: Tuckshop  
Proposed: Formalized tuck shop & take-aways. Restaurant at the back of 19 Tulleken
- Existing: Residential,  
Proposed: Tourist centre, with an information office, NZASM exhibition & curio sales
- Existing: Residential,  
Proposed: Youth hostel
- Existing: Single garage,  
Proposed: Public toilets & staff facility
- Existing: Communes (max 7 tenants per house),  
Proposed: Function to remain, street facing facades to be altered.
- Existing: Private residences,  
Proposed\_ Phase 2: Possible community orientated future alterations, for example a clinic
- Existing: Malombo Lounge  
Proposed\_ Phase 2: Possible future upgrade
- Existing: Zimbabwean church  
Proposed: To remain
- Existing: Open lot/ parking  
Proposed: To remain and serve the precinct
- Existing: Carwash/ parking  
Proposed: To be developed into a drop-off/ collection point for the precinct
- Existing: Pedestrian walkway,  
Proposed: Walkway to be upgraded to be inclusive, with integrated street furniture & signage

APPROACH TO HERITAGE ALTERATION:



5.2.4

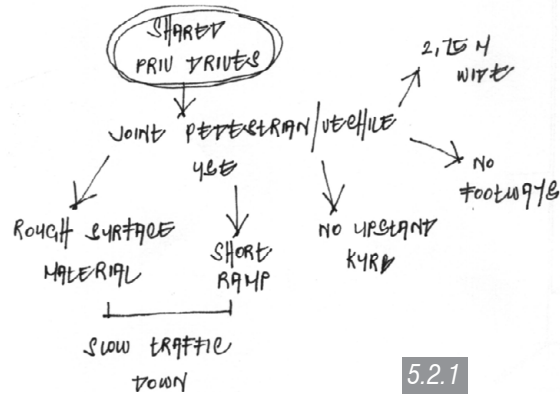
Figure 5.2.3: Urban vision for site (Author 2017)

Figure 5.2.4: Approach to heritage alteration of key structures (Author 2017)

DESIGN FOR THE VEHICLE (4-7)

↳ METRIC HANDBOOK PLANNING &

DESIGN DATA, D. ADLER, 1999, ARCHITECTURAL PRESS: OXFORD



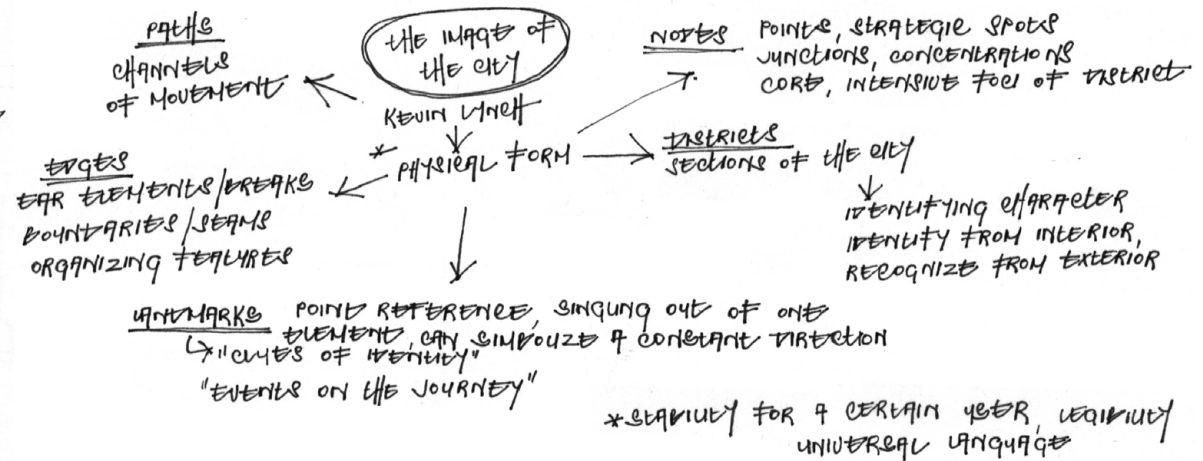
5.2.1

The vision for the site entails the creation of an inclusive tourist precinct (see Figure 5.2.3). The development will affect the local community positively through the creation of job opportunities, the improvement of local infrastructure and the increase of recreational facilities. Tourists will visit the precinct to experience a culturally diverse community in an urban post-colonial South African setting.

Tulleken Street is currently a one-directional east-bound street. Due to the area's proximity to public transport, most residents do not own cars, which contributes to the street's quiet, pedestrian nature. The street will be converted to a shared private drive (De Klerk 2017; Tutt and Adler 1999:4-7) for both vehicular and pedestrian use (see Diagram 5.2.1). The double lane street will be changed to a

single lane, 2,75m wide, and a new rough surface material is to be used (such as cobbles to slow down traffic). The pedestrian walkway is to be paved to ensure an even surface, thereby rendering it inclusive, with visual landmarks at specific points to lead a visitor through the precinct.

The point of arrival is located on the corner of Tulleken and Andries Streets, which has a clear visual connection to the train station. A section of the existing carwash on the northern corner is to be appropriated for a parking lot and drop-off/pick-up zone. On entering the site, the tourist's movement will be dictated by the pedestrian walkway, with additional signage and landmarks acting as visual anchors making use of principles from Kevin Lynch (1960:501), and summarised in Diagram 5.2.2.



5.2.2

The functional requirements are addressed as follows:

**Access to attractions:** All tours and transport can be arranged from the new tourist information office located in 19 Tulleken Street. Tourists can walk from there to the train station, use the pick-up point at the western end of Tulleken Street, or move down Rider Haggard Street, turning left in Clara Street towards the south-eastern pick-up point. The latter is recommended for a richer experience of the precinct and an opportunity to experience the local jazz lounge, Malombo. Daily walking tours will depart from the public square in front of the tourist centre.

**Information:** As noted previously, a tourist centre is located in 19 Tulleken Street. The centre consists of an information office, the NZASM ex-

hibition and a curio shop selling curios produced by the community. The information office has a dedicated consultant to assist travellers, while provision in this proposal is also made for self-exploration of attractions, entailing a kiosk with touch screens and brochure stands. The materiality and heritage features bedded in the interior fabric of the information office, as well as the NZASM exhibition area are conceptualised in this proposal as design references to the original character of the historic dwellings. The NZASM exhibition tells the story of the rise and fall of railway housing in South Africa, with the intention to inspire tourists to go on the NZASM tour through Pretoria, which can be booked through the information office.



**Food and refreshments** (see Figure 5.2.5): The southern half of 19 Tulleken Street is to be adapted to house a restaurant. A range of African cuisine, representative of local, as well as the prevalent nationalities in the community, is served. The menu inspired by the local urban takeaways, such as Nando's and the Moyo restaurant chains. The seating arrangement consists of a variety of indoor seating, as well as uncovered seating on a new timber deck and group seating in a covered external area.

The latter can also serve as a separate venue, rentable for functions. A boma creates the opportunity for outdoor cooking, and can be used for cooking demonstrations and classes or other community events. A buffet and bar is situated against the northern façade of the public and staff

ablutions, from which food can be served from the boma.

The movement and energy existing around 21 and 23 Tulleken Street, with its increased density in younger residents and the popularity of the informal tuckshop, currently housed in a masonry hut along the palisade fence, creates the opportunity for the formalisation of the tuckshop through the alteration of the porch and front room of 21 Tulleken and the addition of a seating deck (refer to Figure 5.2.6).

This area is a likely node for informal interaction between locals and tourists. The tuckshop will also sell take-aways prepared in the restaurant's kitchen in 19 Tulleken Street, with a service link created between the two houses.

**Accommodation** (see Figure 5.2.7): The precinct has different offerings for potential tourist accommodation, with inspiration drawn from the existing NZASM House that functions as a guesthouse (refer to Figure 2.1.8 and 2.1.9). Two well-preserved houses, 11 Tulleken Street and 25 Rider Haggard Street, have been identified as opportunities for Airbnb accommodation in an authentic historic post-colonial setting, with the target market being visitors seeking a cultural experience with ease of access to other historic monuments and museums. The semi-attached cottages of 15 and 17 Tulleken Street are to be combined in the creation of a youth hostel. An addition of a first storey is made to the northern façade of 15 Tulleken Street, allowing for a games room and small bar on the first floor. The new structure becomes a visual

landmark when moving towards the site from the train station.

The private residences along Rider Haggard Street will remain as they are, with the possibility of accommodating future community-orientated interventions, such as the introduction of a clinic or a crèche. In this way, tourism as catalyst is introduced, with the aim of facilitating organic change in the future.



5.2.5



5.2.6



5.2.7

**Diagram 5.2.1:** *The principles of shared private drives summarised (Author 2017)*

**Diagram 5.2.2:** *Principles of the design of public space summarised (Author 2017)*

**Figure 5.2.5:** *Restaurant venue and public ablutions perspective (Author 2017)*

**Figure 5.2.6:** *Tuckshop and take-aways exterior perspective (Author 2017)*

**Figure 5.2.7:** *Youth hostel exterior perspective (Author 2017)*

## 5.2.4 VISION FOR THE CULTURAL LANDSCAPE

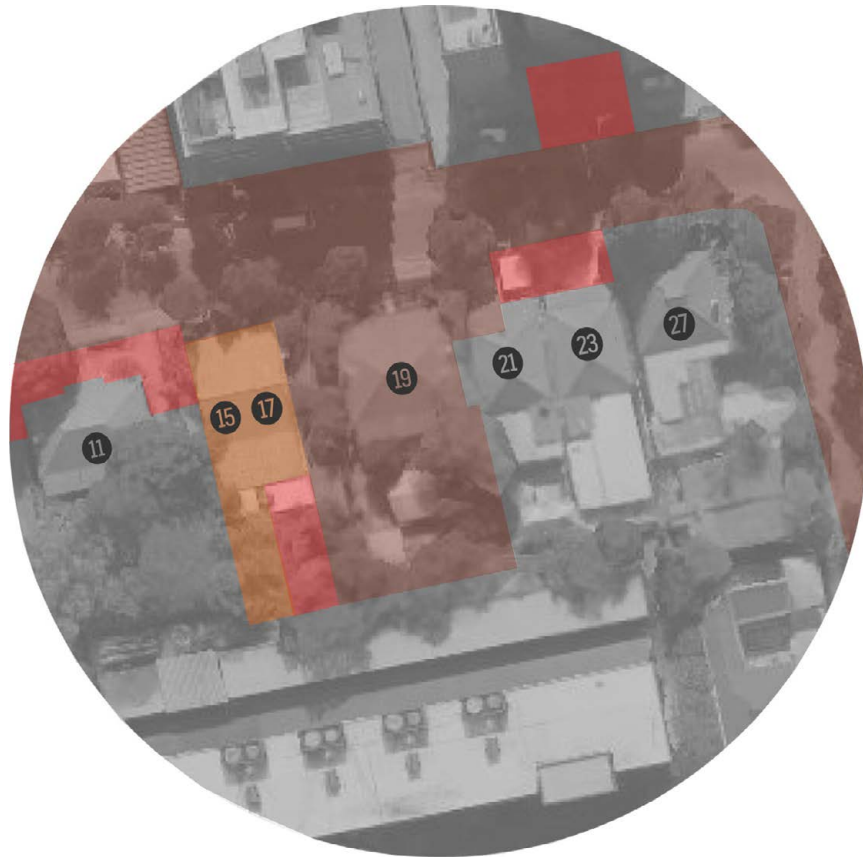
### Degrees of privacy:

The design proposal extends the public realm of the site by opening up 19 Tulleken Street. The transition from public to semi-public, semi-private to private is subtle, with public amenities grouped for legibility and sensitive private areas protected with physical boundaries, ranging from changes in floor materials to screening devices and mason-

ry walls, depending on the requirements of the private area (see Figure 5.2.8). The organisation of functions in the Bo-Kaap is used as inspiration (please refer back to Section 4.3 in Chapter 4).

**Figure 5.2.8:** *Degrees of privacy (Author 2017)*

**Figure 5.2.9:** *Layout of the social strategy (Author 2017)*



● Public ● Semi-public ● Semi-private ● Private

5.2.8

### Social landscape:

Through informal discussions with residents (please refer back to Section 2.1.5.2 in Chapter 2), it has been confirmed that the majority of residents are tenants in Tulleken and Rider Haggard Streets. Numbers 11, 15, 17 and 19 Tulleken Street all belong to one owner who inherited the houses and lives outside of the city, while 21 and 23 Tulleken Street belong to an owner who has converted, with complete disregard for the heritage fabric, the two houses into communes to accommodate up to seven residents per house.

In line with the design proposal, 15 and 17 Tulleken Street is combined to become a youth hostel, while 19 Tulleken Street is altered to house a tourist centre. The tenants residing in these properties will be relocated once their rental agreements end. A section of the street-facing façade of 21 Tulleken Street will be altered to integrate the tuckshop into the existing fabric, with the result that one tenant will not be able to renew his/her rental contract once it has ended. The tenants in 11 Tulleken Street and 25 Rider Haggard Street, respectively, are given the opportunity to gain an additional income by hosting AirBnB accommodation in the second bedrooms of their homes. All the other private residences will remain as they are.

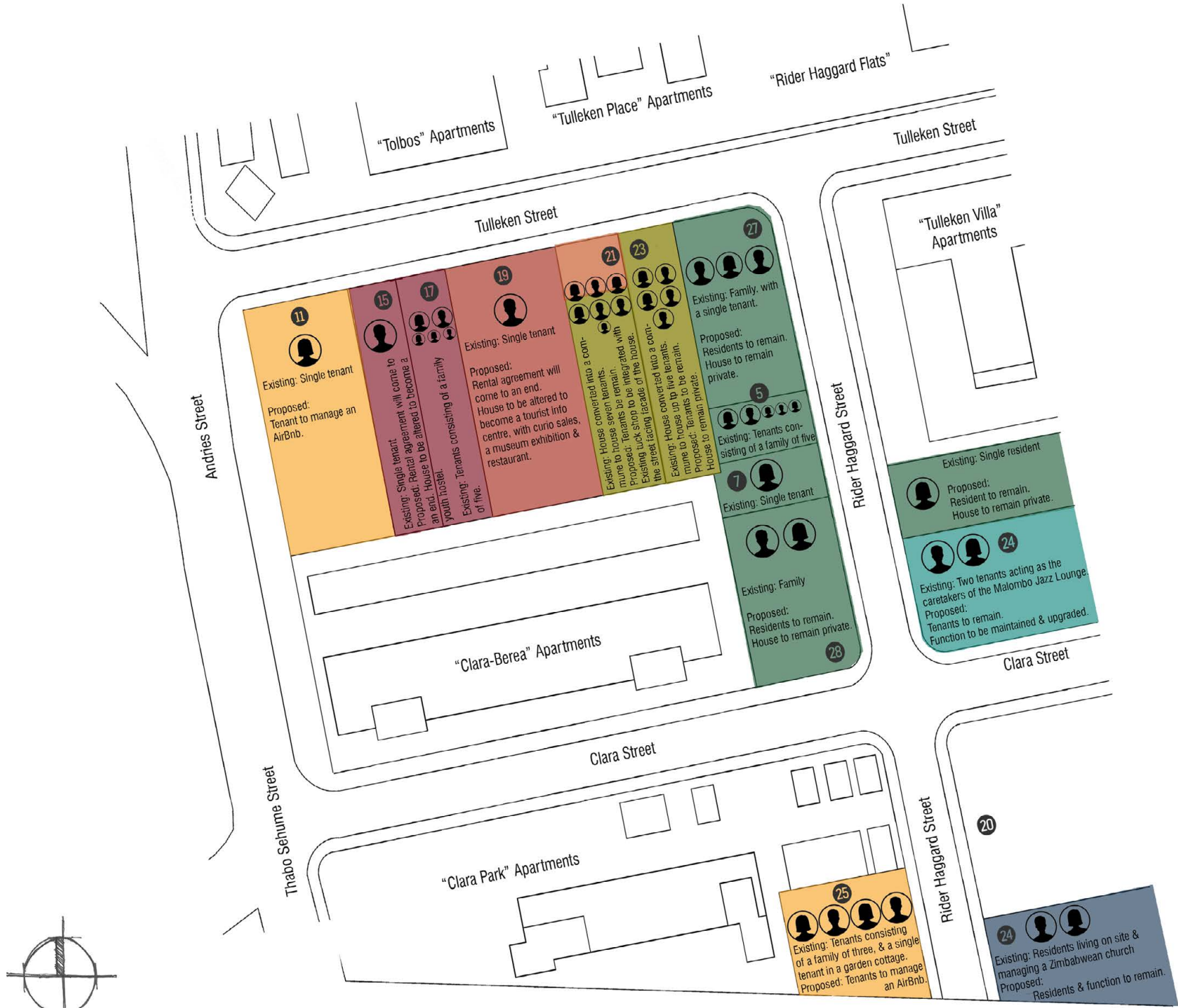
The existing social conditions are significant and should be preserved as far as possible. The design intervention is dually aimed at creating a

destination for tourists and uplifting the community on site, though the creation of jobs and recreational facilities (see Figure 5.2.9).





### Natural landscape:

A strategy is devised for the existing trees on the site, and are in line with Green Star SA criteria. What appears to be the same species of tree line the sides of Tulleken, Rider Haggard and Clara Streets. Their positions vary between 10-15m intervals. This is a possible result of formal landscaping back when the area was established, and leads to the conclusion that the trees in the public realm are older than 60 years. The trees situated around the houses and in backyards are of a variety of species, and the degree of maintenance of the gardens depends on the resident. Formal landscaped gardens are not present in the area.

The existing trees contribute to the cultural significance and character of the site (see Figure 5.2.10). The trees aid in climate control and should be protected due to their age. The trees lining the road are the most significant as they form part of the area layout and provide a rhythm to the movement along the street. The proposed treatment of these trees consists of trimming the branches to improve legibility and visual access to the precinct. Some trees around 15, 17 and 19 Tulleken Street will need to be uprooted to allow for clear views of and for the tourist centre and youth hostel; these trees can, however, be transplanted to elsewhere in the precinct.

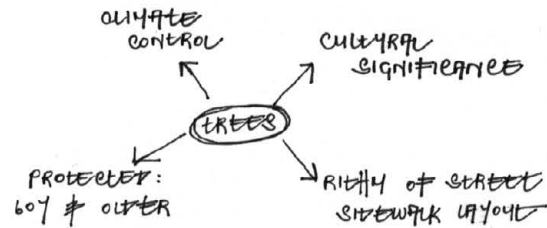


5.2.9

-  **Tree A:**  
Planted on sidewalk - to remain & be preserved
-  **Tree B:**  
Planted in private erf - to remain & be preserved
-  **Tree C:**  
Planted on sidewalk/ private erf - to be removed
-  **Lawn/ Landscaping**



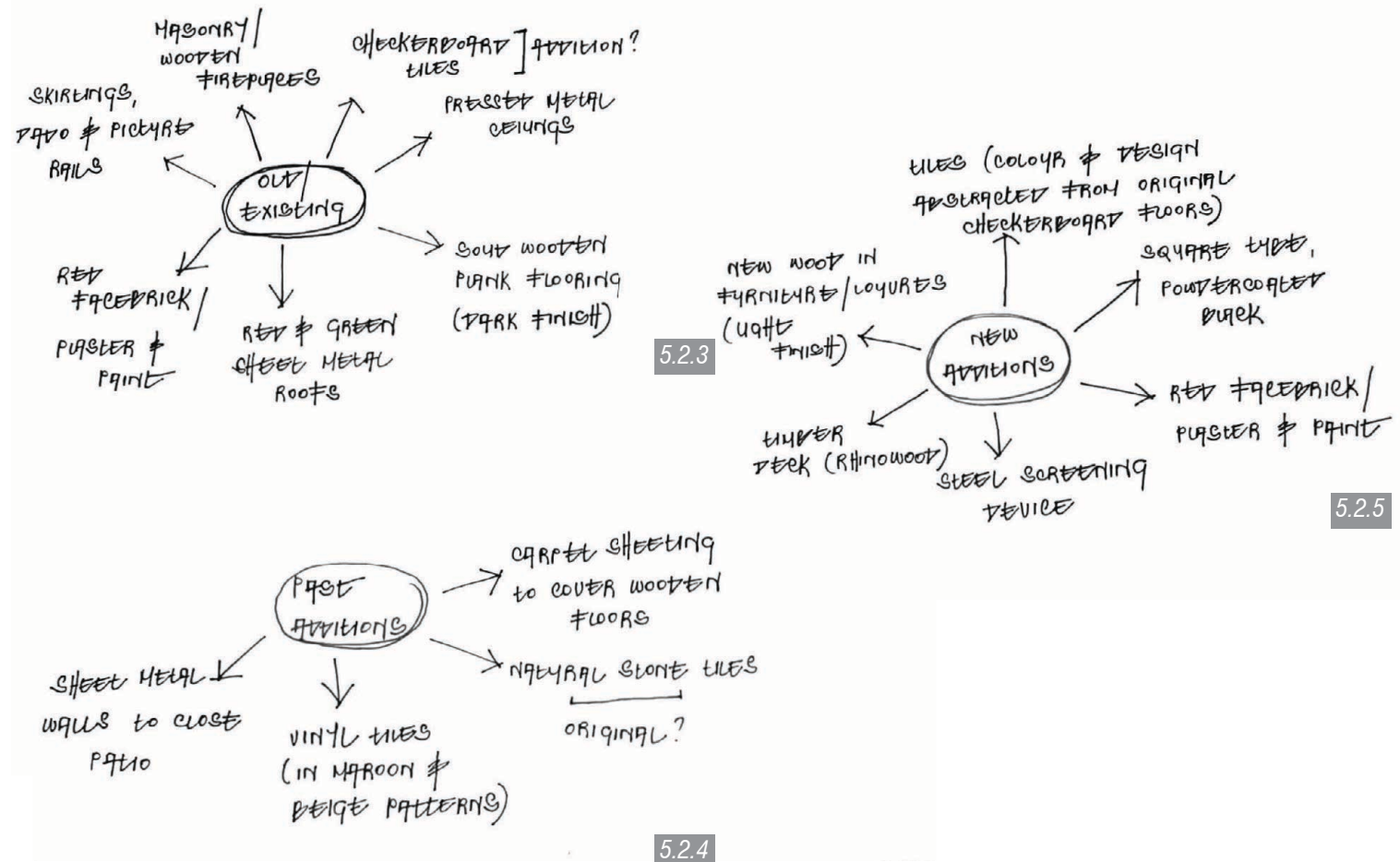
**Tree A:** To be trimmed by specialist



**Figure 5.2.10:** Strategy for the trees on the site  
(Author 2017)

## 5.2.5 MATERIALITY

The materiality of the existing fabric of the houses is analysed (see Figure 5.2.3 and 5.2.4) to inspire the palate for the intervention (see Figure 5.2.5). The characteristics and materiality of existing finishes like the hardwood plank flooring, and checkerboard and vinyl tiles are explored and reinterpreted. The patterns abstracted from the analysis of the houses are reused in new floor finish layouts and built-in elements. The concept of simplicity in the materiality of the intervention is inspired by the work of Sverre Fehn and David Chipperfield Architects (Chapter 4), with the new complimenting the old and becoming a single entity (relating back to the theory of Brooker and Stone in Chapter 3).



**Diagram 5.2.3:** Summary of the old/existing/original material (Author 2017)

**Diagram 5.2.4:** Summary of the materiality of past additions (Author 2017)

**Diagram 5.2.5:** Summary of the materiality of new additions (Author 2017)

PALETTE A: EXISTING MATERIAL, FORM AND COLOUR



## PALETTE B: NEW MATERIAL, FORM AND COLOUR



**Figure 5.2.11:** Palette A: Collage of existing material, form and colour (Author 2017)

**Figure 5.2.12:** Palette B: Collage of new material, form and colour (Author 2017)

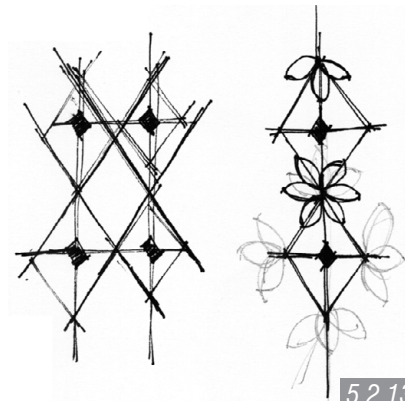
## 5.2.6 PATTERN DEVELOPMENT

Due to the sensitive interaction between public and private spaces, the need developed to separate spaces with a semi-private element, leading to the design of a screening device that can be used in multiple locations on site. The main use of this screening device is as the infill panels of the external covering over the restaurant venue at the back of the tourist centre (see Figure 5.2.16). It is further implemented to separate the patio deck at the back of the youth hostel from the public circulation space and as barrier between the spill-out deck of the youth hostel's dormitories and the laundry area. The pattern of the screen (see Figure 5.2.13) is abstracted from an analysis of the flower motifs in the existing stained-glass windows in 19 Tulleken Street (refer back to Figure 2.1.57) and 10 Rider Haggard Street (see Appendix B).

The pattern also appears in the geometric patterns on the vinyl tiles in 15 Tulleken Street (refer back to Figure 2.1.44) and 25 Rider Haggard Street (see Appendix B). A collage of these found patterns is seen in Figure 5.2.14.

Figure 5.2.13: Pattern development (Author 2017)

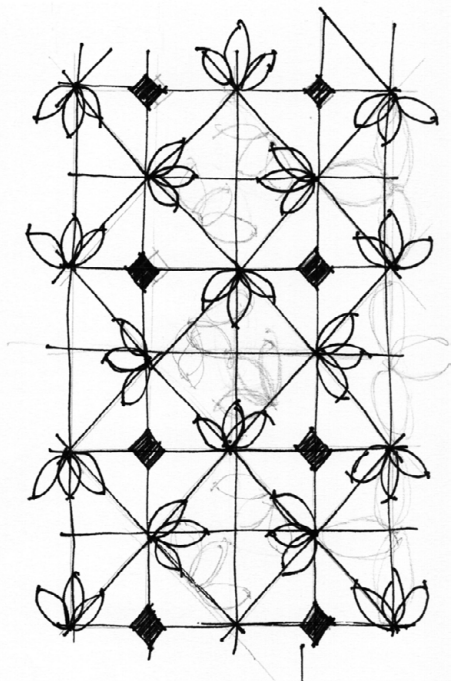
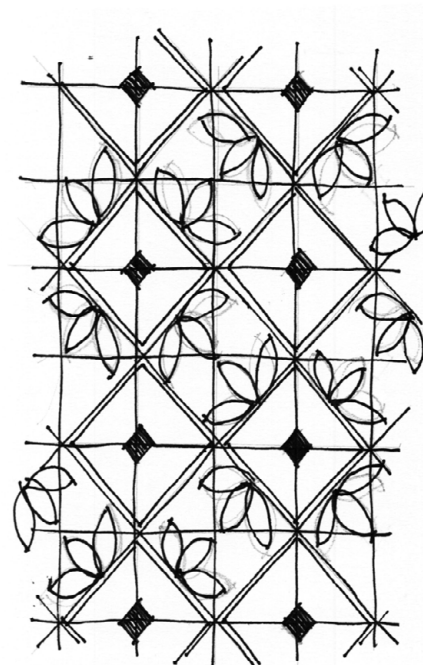
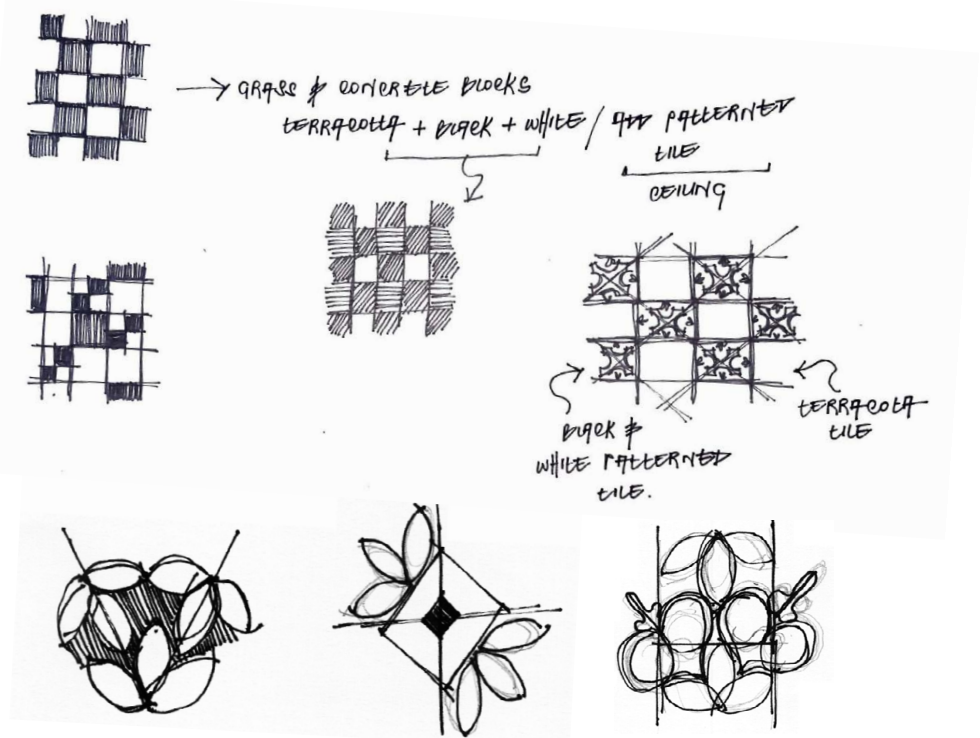
Figure 5.2.14: Collage of patterns found on the interior (Author 2017)



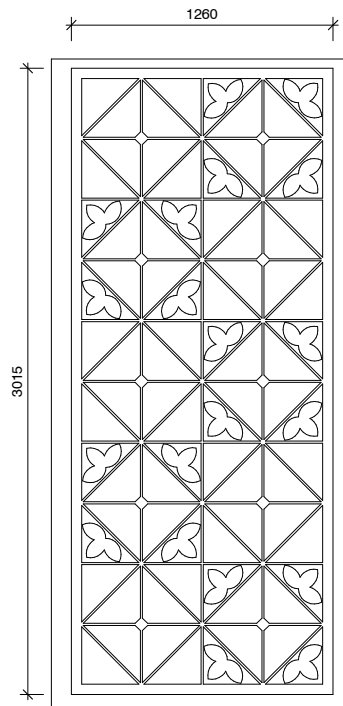
5.2.13



5.2.14

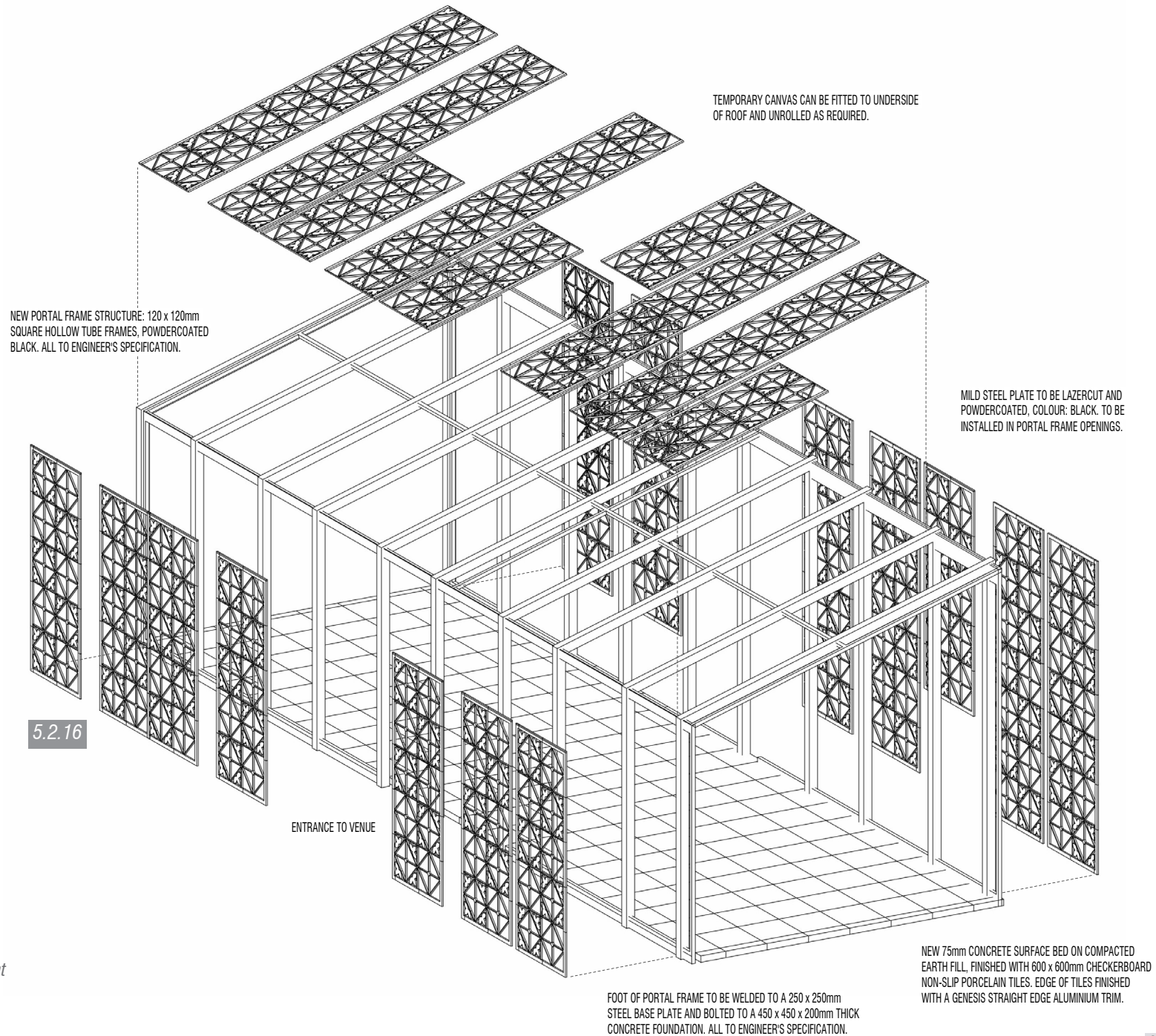






5.2.15

Figure 5.2.15: A screen panel, not to scale  
(Author 2017)



NEW PORTAL FRAME STRUCTURE: 120 x 120mm SQUARE HOLLOW TUBE FRAMES, POWDERCOATED BLACK. ALL TO ENGINEER'S SPECIFICATION.

TEMPORARY CANVAS CAN BE FITTED TO UNDERSIDE OF ROOF AND UNROLLED AS REQUIRED.

MILD STEEL PLATE TO BE LASERCUT AND POWDERCOATED, COLOUR: BLACK. TO BE INSTALLED IN PORTAL FRAME OPENINGS.

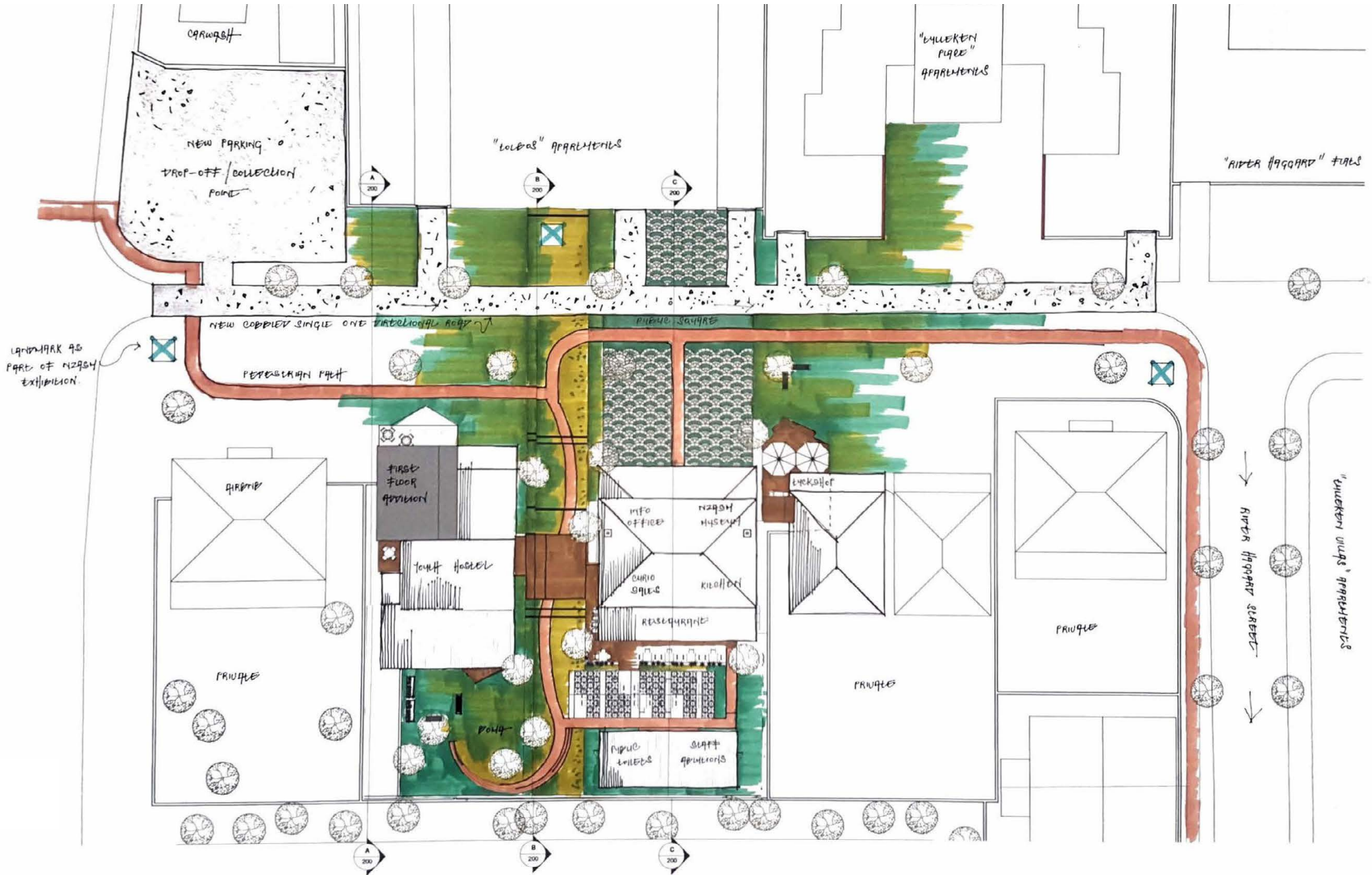
ENTRANCE TO VENUE

5.2.16

FOOT OF PORTAL FRAME TO BE WELDED TO A 250 x 250mm STEEL BASE PLATE AND BOLTED TO A 450 x 450 x 200mm THICK CONCRETE FOUNDATION. ALL TO ENGINEER'S SPECIFICATION.

NEW 75mm CONCRETE SURFACE BED ON COMPACTED EARTH FILL, FINISHED WITH 600 x 600mm CHECKERBOARD NON-SLIP PORCELAIN TILES. EDGE OF TILES FINISHED WITH A GENESIS STRAIGHT EDGE ALUMINIUM TRIM.

5.2.7 DEVELOPMENT OF A SITE PLAN AND FLOOR PLANS



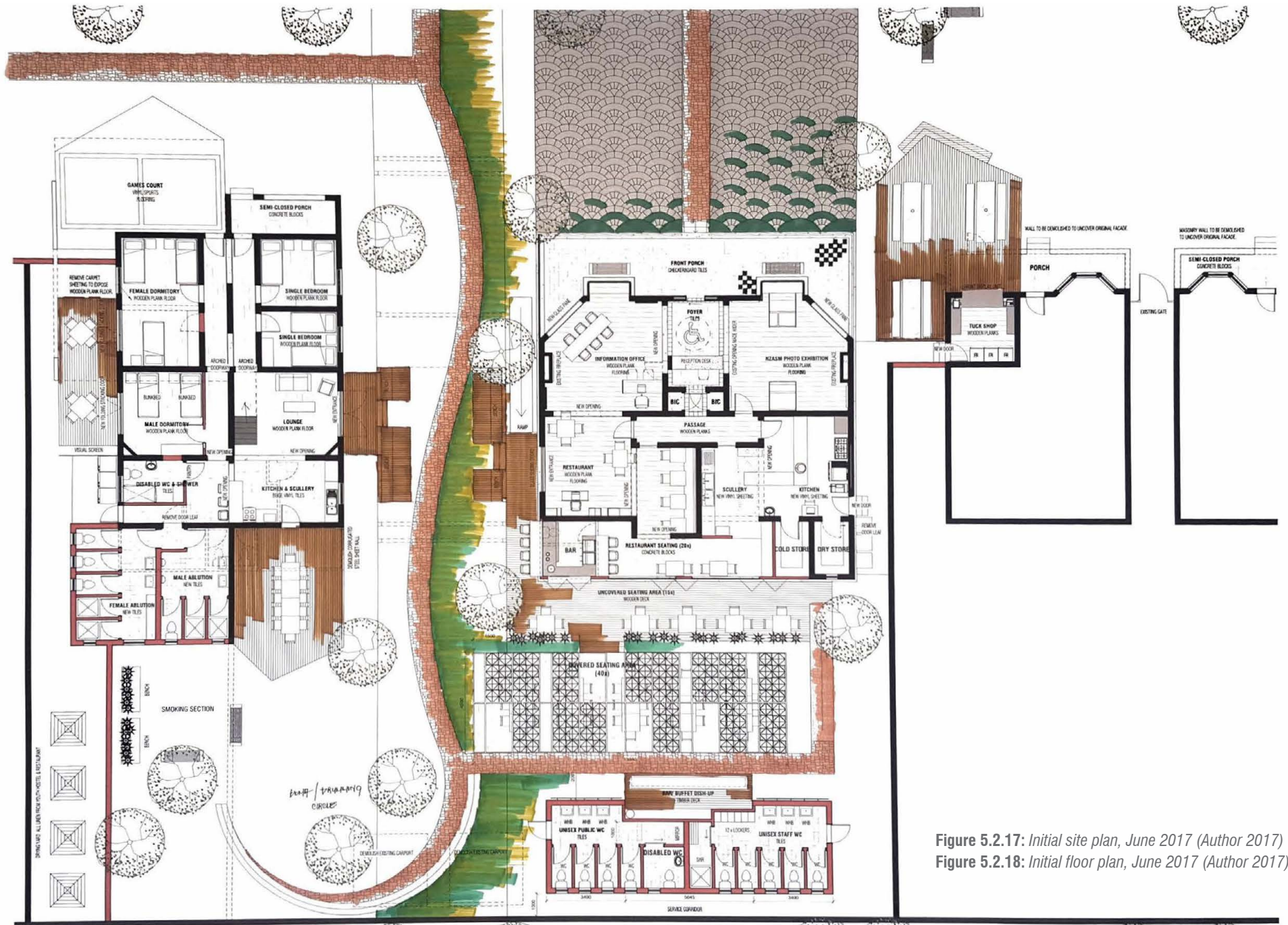
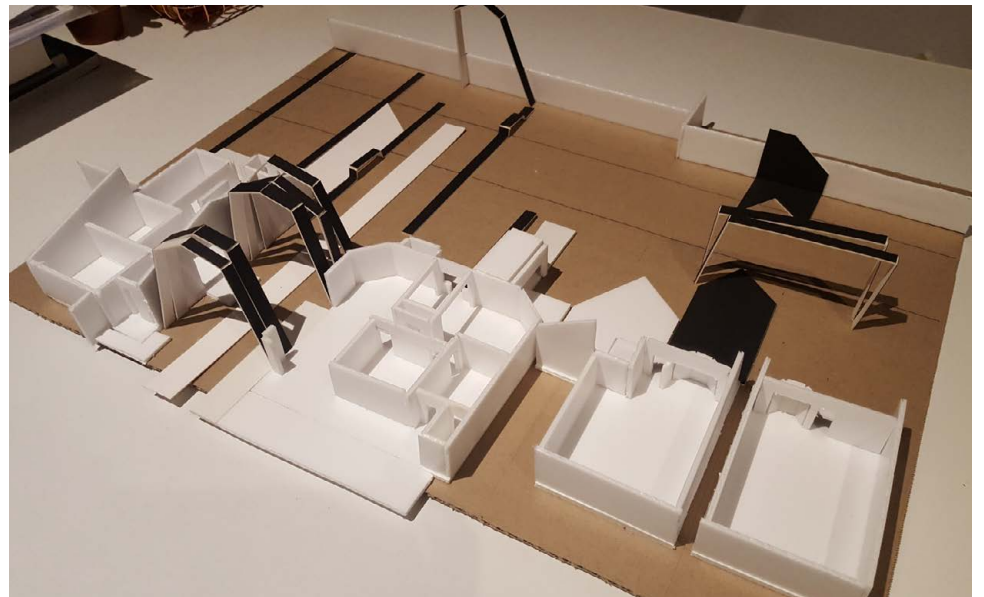
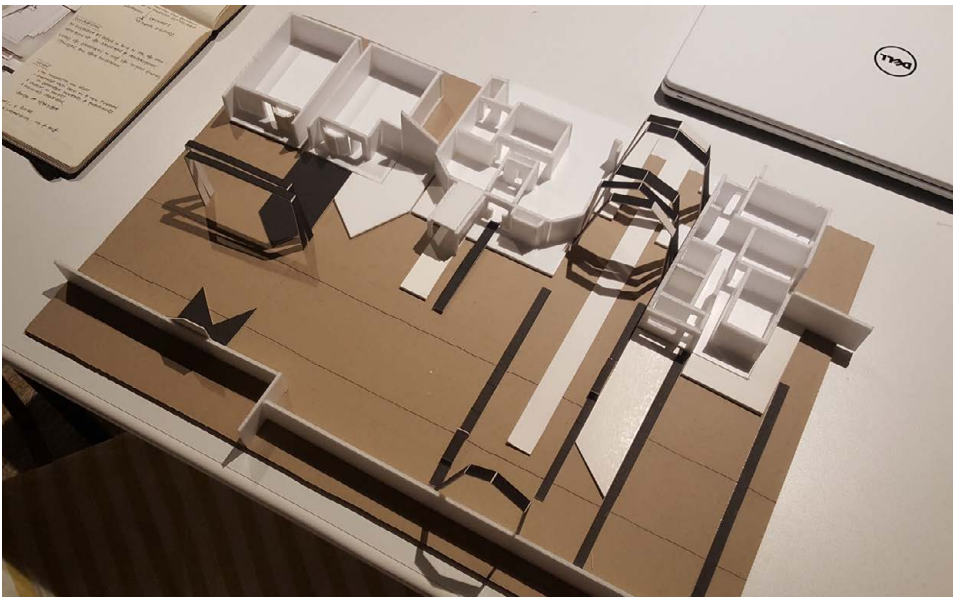


Figure 5.2.17: Initial site plan, June 2017 (Author 2017)  
Figure 5.2.18: Initial floor plan, June 2017 (Author 2017)

### 5.2.8 CONCEPTUAL MODELS

Figures 5.2.19: Conceptual development through models (Author 2017)





# PART 3: TECHNICAL DEVELOPMENT

## 5.3.1 INTRODUCTION

The alteration of heritage fabric is required for a successful change in function. Through the design proposal, the domestic function of the historic residences, consisting of 15, 17, 19 and 21 Tulleken Street, have been altered so as to house a tourist centre, youth hostel and tuckshop, respectively. The technical resolution of the various interventions is informed by the approach to the alteration of heritage fabric (established through context, theory, case studies and precedent investigations in Chapter 4) and informs a strategy for the addition of new fabric, with the aim of a successful change in function from a residential site to a tourist precinct.

Guidelines to celebrate the memory of demolished heritage fabric, and connecting old and new fabric, have been established through an investigation of the interventional work of Carlo Scarpa and Sverre Fehn, the Burra Charter, and subsequent statement of significance and theory on heritage alteration. These guidelines are used to test and iterate the proposed interventions, for full technical resolution.

## 5.3.2 RESEARCH QUESTIONS

### Main technical question:

- How can the approach to heritage fabric (as presented in Chapters 2 to 4) establish a strategy for the addition of new fabric, with the aim of realising a successful change in function?

### Sub questions:

- Where heritage fabric is demolished in preparation for new fabric, how will the memory of the old be celebrated?
- What approach will be undertaken to connect old and new fabric?
- In a simplified material palate, can a universal joining detail be established for new interior and exterior design elements?

## 5.3.3 OUTCOME

Certain interior and architectural interventions have been selected for technical resolution due to their complexity in materiality and joining, with the outcome being the detail resolution of the additions in their entirety. Materiality and form iterations offer a re-interpretation of the existing, with the aim of establishing a fresh palette that introduces new materials with a clear link to the old. Such iterations make reference to the aforementioned works of Sverre Fehn and David Chipperfield Architects in Chapter 4.

The old and new materials exist as one, without a loss of identity through an interventional approach (Brooker and Stone 2004:79). This is achieved through the joining of new materials to existing fabric while taking into account the characteristics of each material, as well as how the respective materials age.

The methodology consists of developing guidelines to celebrate the memory of demolished heritage fabric and connecting old and new fabric, against which the proposed alterations can be tested and iterated. These guidelines have been established through an investigation of interventional precedents; the Burra Charter, and its subsequent statement of significance; and theory on heritage alteration (as presented in Chapters 2

to 4). Additionally, the environmental sustainability is tested against Green Star SA criteria (refer to 5.3.16), and social sustainability against the theoretical concept of resilience.

## 5.3.4 AREAS OF RESOLUTION

### Main architectural intervention for technical resolution:

5.3.9 The First-Floor Addition to the Youth Hostel

### Main interior interventions for technical resolution in the tourist centre:

5.3.10 The Reception Area

5.3.11 The NZASM Exhibition

5.3.12 The Tourist Information Office

5.3.14 The Restaurant Kitchen and Bar

### Architectural interventions to be resolved as objects:

5.3.15 The Tuckshop Addition to 21 Tulleken Street

### 5.3.5 APPROACH TO TECHNICAL RESOLUTION

Three possible approaches can be taken to the alteration of heritage fabric: the copy, the complimentary and the contrast. Guidelines for the three approaches have been established through the study of Carlo Scarpa's interventional work (Brümmer 2016). The outcome of all the approaches is for the old and new to become one without a loss of identity.

**The copy:** The copy consists of reusing the existing concept to mimic old fabric. The imitation can be of the type of material, form, pattern, proportioning system, surface texture, technology, construction technique and/or joining method of the existing. Fred Scott (2008:135) refers to this copy or 'mimicry' as "...both reverential and light-hearted, or more solemn, but should be the outcome of learning, of structured knowledge of what is to be copied".

**The contrast:** The contrast consists of choosing new material to create a juxtaposition with the old. The contrast can be the type of material, form, pattern, proportioning system, surface texture, technology, construction technique and/or joining method with the existing. William Morris (1878) refers to this as "...a building in which the many changes, though harsh and visible enough, were, by their very contrast, interesting and instructive and could by no possibility mislead".

**The complimentary:** The complimentary approach lies between the contrast and the copy, and is a reinterpretation of the existing fabric. New fabric is chosen that will work functionally with the old, while complimenting it in the type of material, form, pattern, proportioning system, surface texture, technology, construction technique and/or joining method.

Carlo Scarpa's treatment of the Castelvecchio Museum's ground floor is an example of a complimentary intervention (see Figure 5.3.1). The new floor consisting of concrete is subdivided by a stone fascia grid, curbed in Prun stone and pulled back from the wall, articulating the existing corner (Albertini and Bagnoli 1988:218). Concrete and stone are complimentary materials when related to the existing stone walls of the museum.



Figure 5.3.1: Floor inlay, Castelvecchio (ArchiObjects 2014)

### 5.3.6 HERITAGE ALTERATION AUDIT

#### Criteria for new material

- Does the new material respect the character of the old?
- Is the new material a copy, in contrast to, or does it compliment the old?
- Can the new material be added without causing degradation to the old, for example through corrosion?
- How will the new material age when compared to the old?
- Can the addition of new material be reversed for future alterations?
- Does the choice of new material meet the functional requirements?
- Does the choice of new material contribute to the resilience of the precinct and community?
- How will the new material be joined to the old? Is the fixing temporary or permanent and what is the impact on the old?

### 5.3.7 FINAL DESIGN: PLANS, ELEVATIONS, SECTIONS AND DETAILS



THE NZASM TOURIST PRECINCT SITE PLAN

Figure 5.3.2: Final site plan, not to scale (Author 2017)



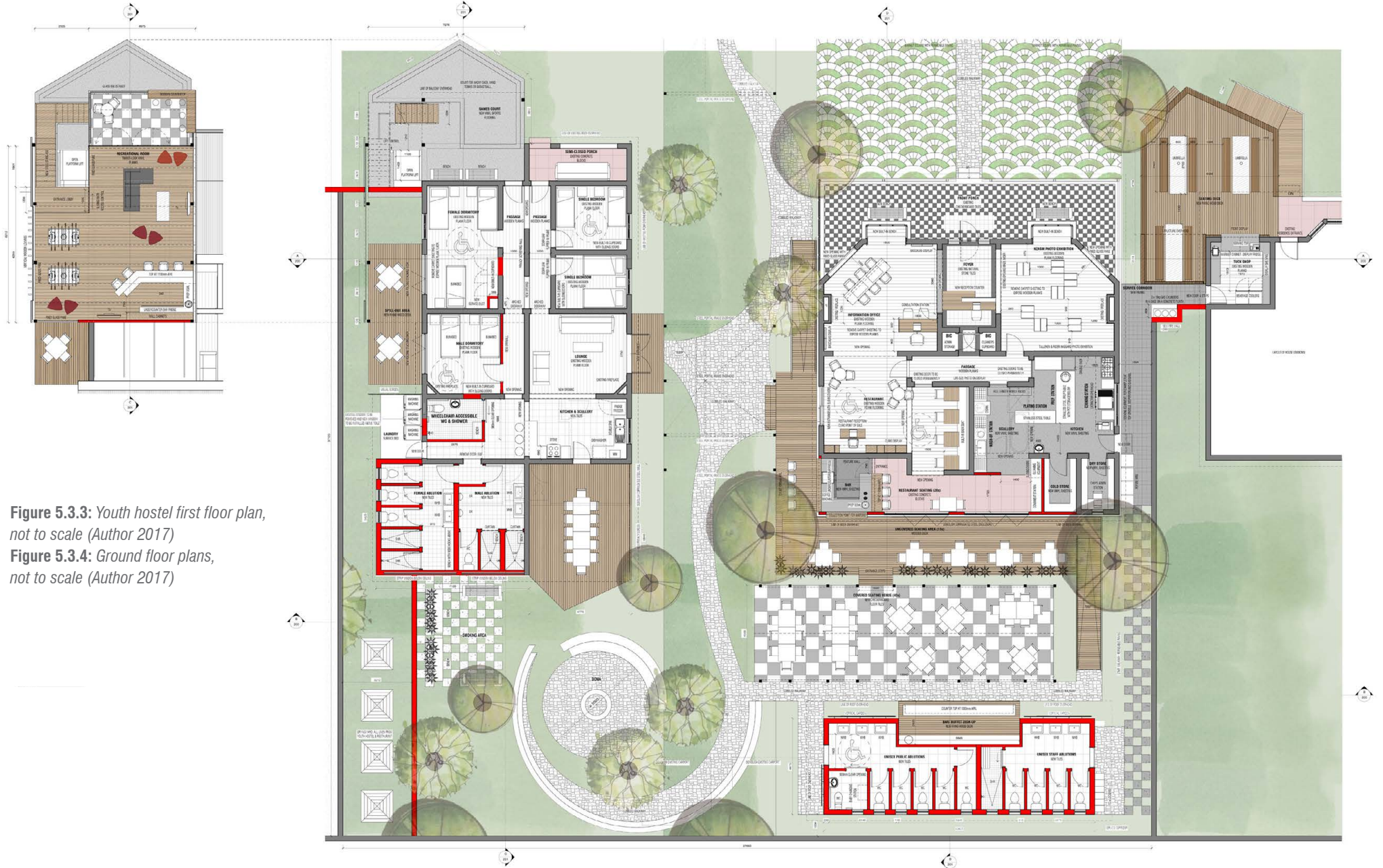


Figure 5.3.3: Youth hostel first floor plan, not to scale (Author 2017)

Figure 5.3.4: Ground floor plans, not to scale (Author 2017)

YOUTH HOSTEL, TOURIST CENTRE AND TUCKSHOP FLOOR PLAN



15 - 23 TULLEKEN NORTHERN ELEVATION

**Figure 5.3.5:** 15-23 Tulleken Northern elevation (East to West), not to scale (Author 2017)  
**Figure 5.3.6:** 15-21 Tulleken Southern elevation (West to East), not to scale (Author 2017)



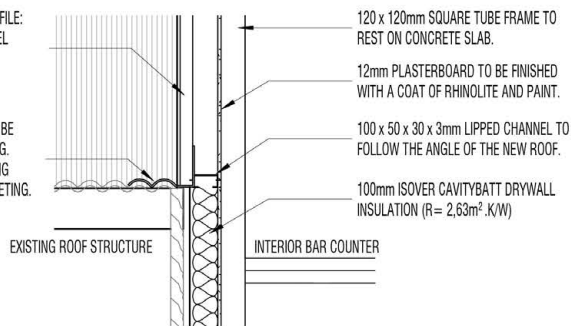
15 - 21 TULLEKEN SOUTHERN ELEVATION



SECTION A: EAST - WEST

CHROMADEK Z200 SHEET METAL ROOFING, PROFILE: BROWNBUILT, COLOUR: DARK DOLPHIN ON STEEL PURLINS 1200mm C/C. TO BE INSTALLED TO MANUFACTURER'S SPECIFICATIONS.

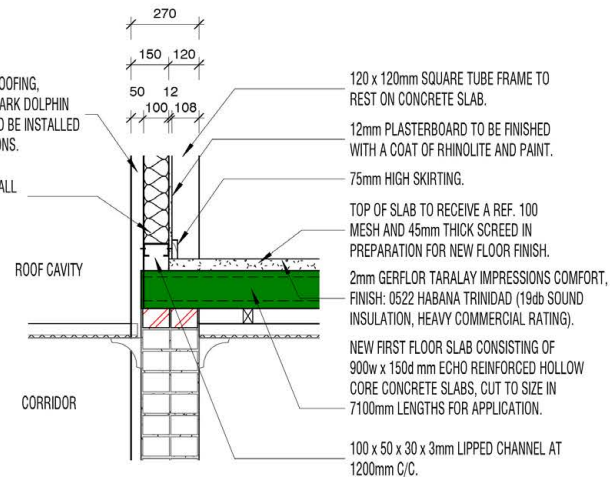
CONNECTION BETWEEN OLD AND NEW ROOF TO BE WATERPROOFED WITH A 0.6mm SHEET FLASHING. FLASHING TO BE POSITIONED ON TOP OF EXISTING SHEETS AND TO RUN IN UNDERNEATH NEW SHEETING.



YOUTH HOSTEL ROOF CONSTRUCTION DETAIL 2

CHROMADEK Z200 SHEET METAL ROOFING, PROFILE: BROWNBUILT, COLOUR: DARK DOLPHIN ON STEEL PURLINS 1200mm C/C. TO BE INSTALLED TO MANUFACTURER'S SPECIFICATIONS.

100mm ISOVER CAVITYBATT DRYWALL INSULATION (R= 2,63m<sup>2</sup>. K/W)



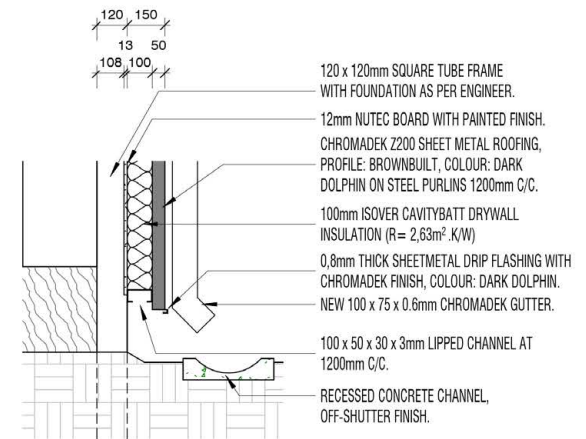
YOUTH HOSTEL ROOF CONSTRUCTION DETAIL 3

Figure 5.3.7: Section A: East - West, not to scale (Author 2017)

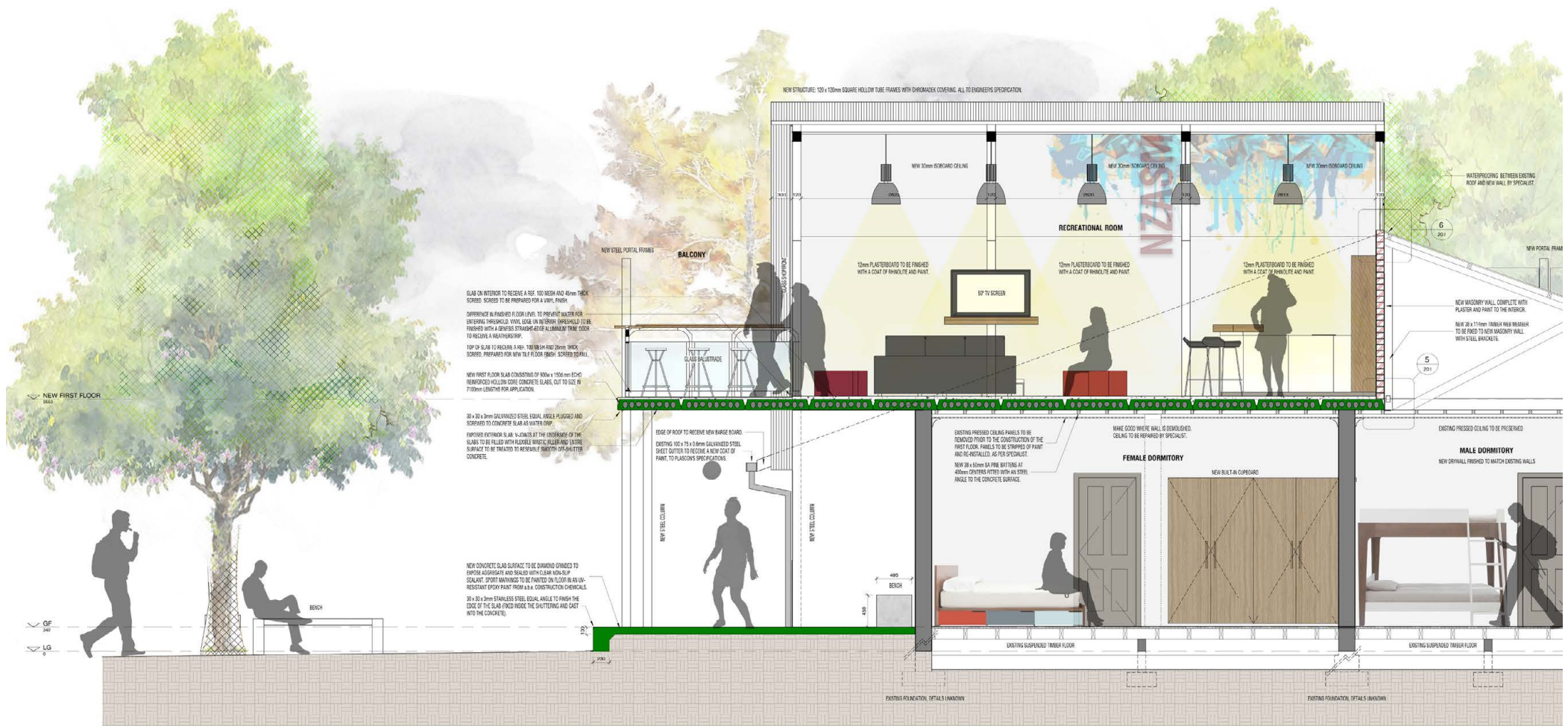
Figure 5.3.8: Youth hostel detail 2, not to scale (Author 2017)

Figure 5.3.9: Youth hostel detail 3, not to scale (Author 2017)

Figure 5.3.10: Youth hostel gutter detail 4, not to scale (Author 2017)



YOUTH HOSTEL GUTTER CONSTRUCTION DETAIL 4



SECTION C: YOUTH HOSTEL (NORTH - SOUTH)

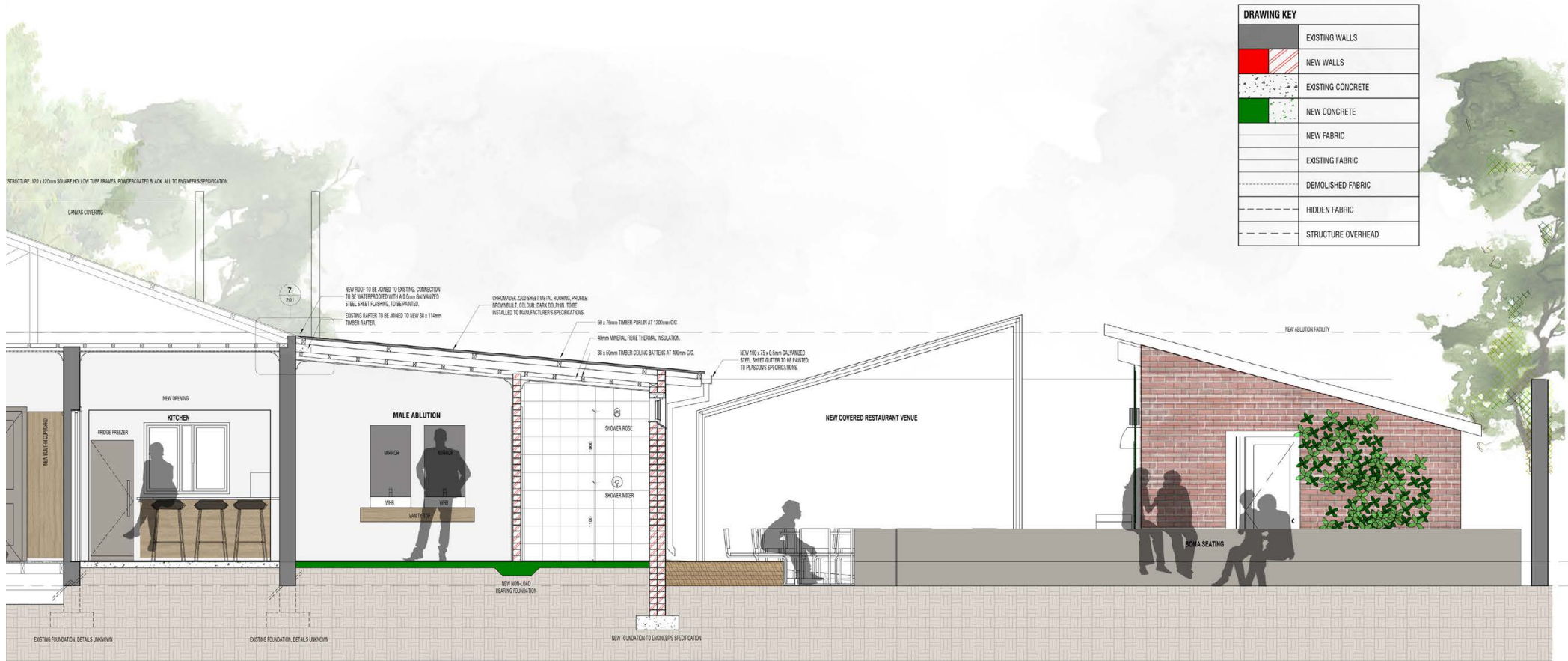
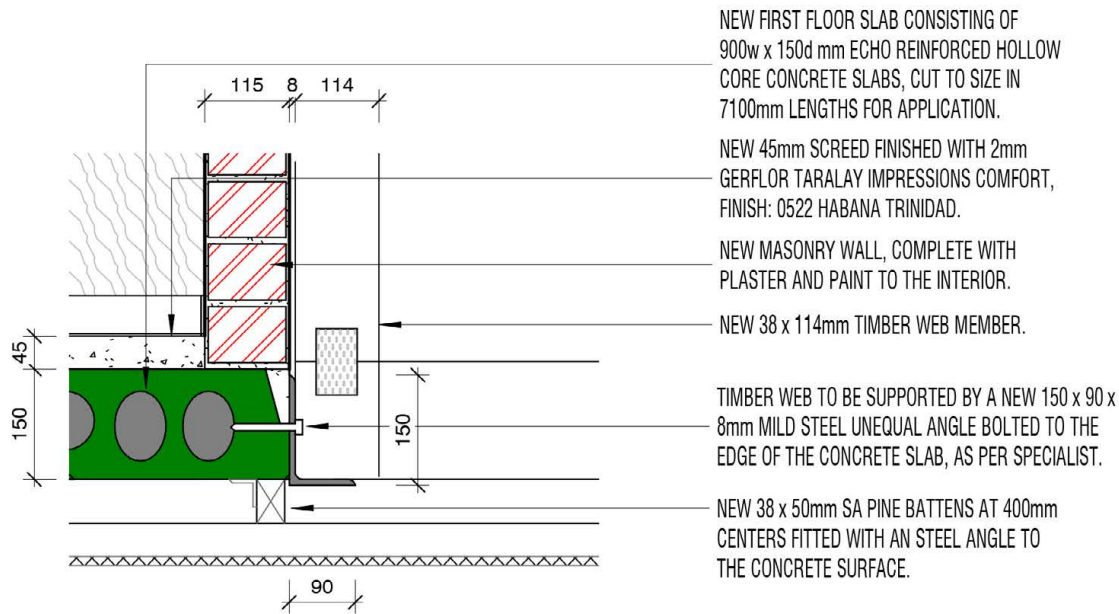
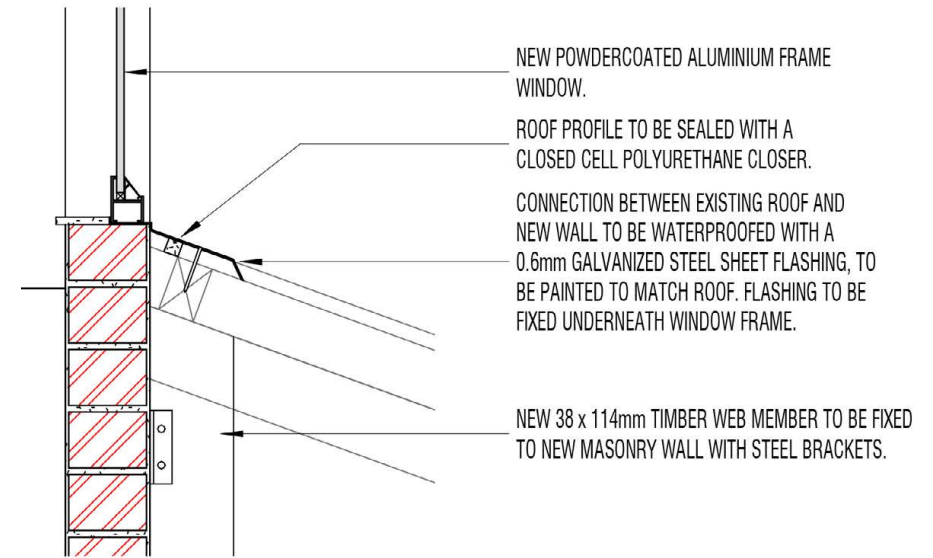


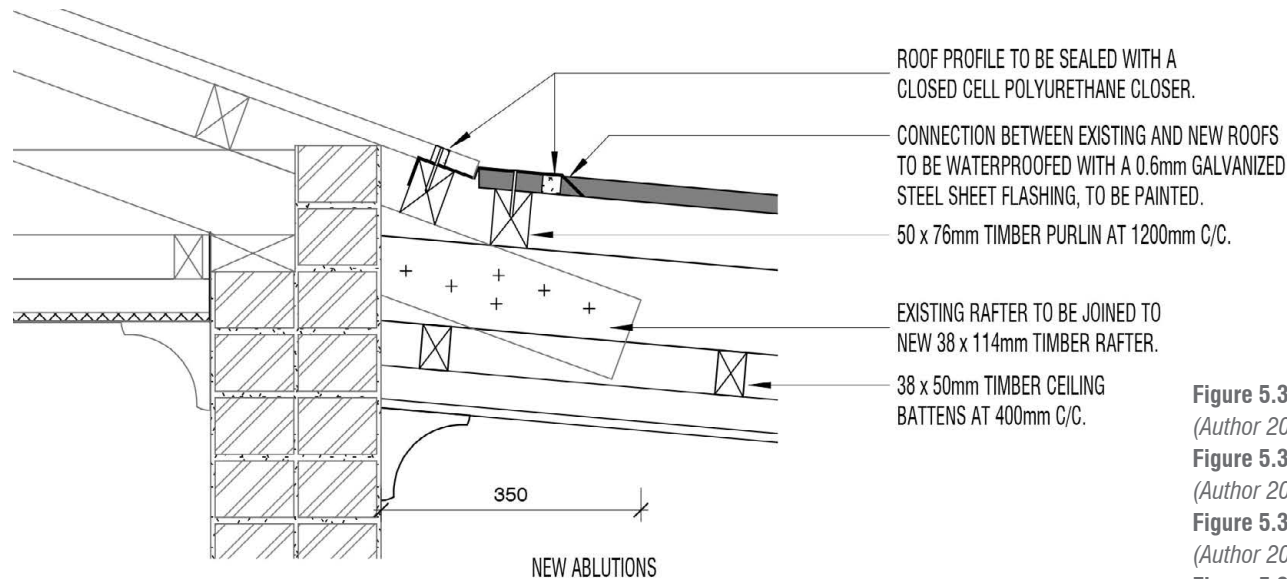
Figure 5.3.11: Section C: Youth Hostel (North - South), not to scale (Author 2017)



YOUTH HOSTEL ROOF CONSTRUCTION DETAIL 5



YOUTH HOSTEL ROOF CONSTRUCTION DETAIL 6



YOUTH HOSTEL ROOF CONSTRUCTION DETAIL 7

Figure 5.3.12: Youth Hostel Detail 5, not to scale (Author 2017)

Figure 5.3.13: Youth Hostel Detail 6, not to scale (Author 2017)

Figure 5.3.14: Youth Hostel Detail 7, not to scale (Author 2017)

Figure 5.3.15: Precinct approach exterior perspective (Author 2017)





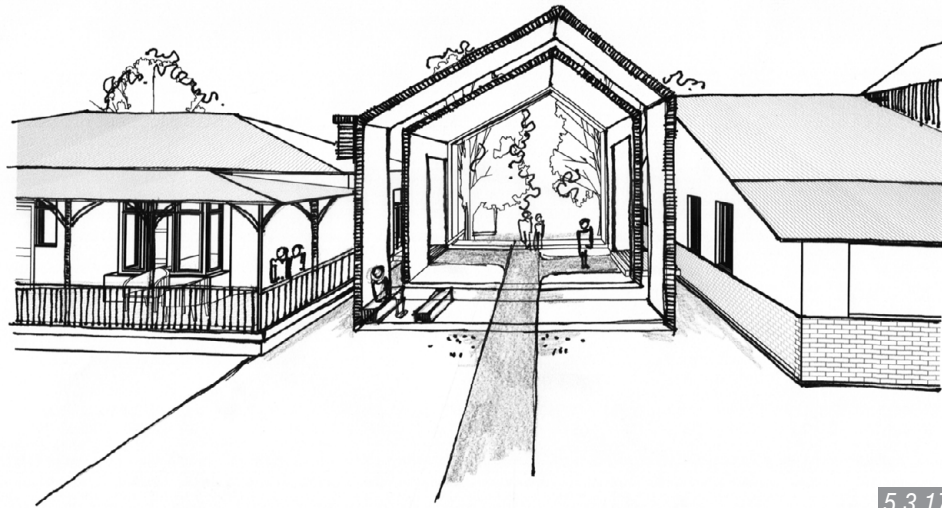
SECTION D: TOURIST INFORMATION, RESTAURANT, BAR AND ABLUTIONS (SOUTH - NORTH)





Figure 5.3.16: Section D: Tourist information, restaurant, bar and ablutions (South - North), not to scale (Author 2017)

### 5.3.8 ENTRANCE STRATEGY



5.3.17

With the objective of attracting visitors and locals to the newly created nodes and “back yard” space of the precinct a circulation spine is created between the youth hostel in 15 and 17 Tulleken Street and the tourist centre in 19 Tulleken Street (see Figure 5.3.4). Visual landmarks are used to lead users through the space, in this instance portal frames that accentuate the walkway spine (see Figure 5.3.17). The form of the portal framing devices is inspired by the simplified shape of a traditional house (refer back to Figure 5.1.6), and by covering some sections between the portal frames, shaded pause areas are created along the walkway. Access is gained to the new main entrance of the youth hostel and the restaurant in 19 Tulleken Street located on their side facades,

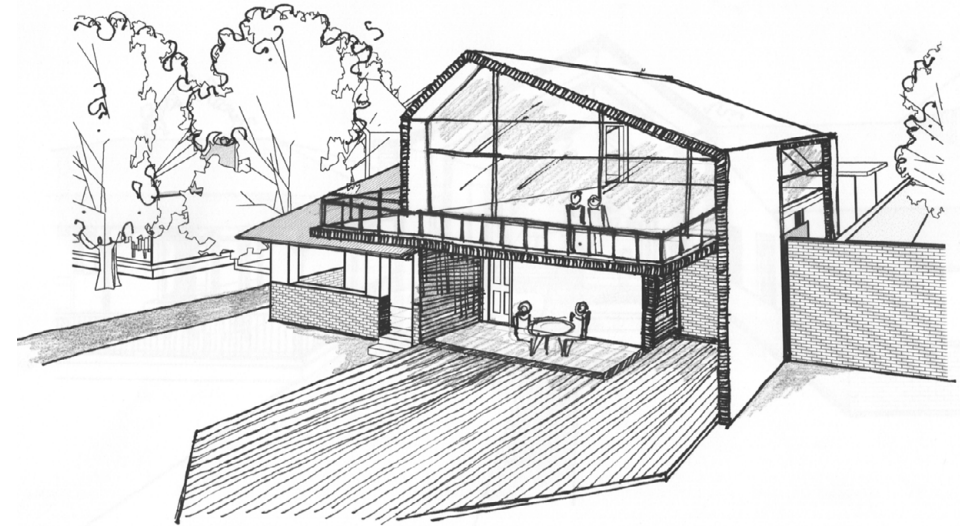
with the end destination possibilities being the back garden, boma or public ablutions.

**Figure 5.3.17:** View of the portal frames and walkway (Author 2017)

**Figure 5.3.18:** Progression in 3D development of the youth hostel's street facing facade (Author 2017)

**Figure 5.3.19:** Youth hostel exterior perspective (Author 2017)

### 5.3.9 YOUTH HOSTEL: DESIGN AND RESOLUTION



5.3.18



5.3.19

For the creation of the youth hostel as a tourist accommodation option, the interior spaces of 15 and 17 Tulleken Street were combined. When entering the precinct from the train station, the youth hostel's close proximity makes it an ideal visual landmark (refer to Figure 5.3.2), inspiring the first-floor structural addition.

The residential houses' heritage fabric was assessed and it was found that the identical mirrored facades of the two houses consisted of little precious heritage fabric (refer back to Figure 2.1.45). This informed the decision to strip back the façade and a part of the roof of 15 Tulleken Street to introduce a structural change, while preserving 17

Tulleken Street, not only as heritage façade, but also as memory of what 15 Tulleken Street looked like before the alteration.

The youth hostel's main entrance is located on its eastern side, with the restaurant reception in the adjacent 19 Tulleken Street doubling up as the youth hostel check-in. The hostel consists of double rooms, and a female and male dormitory with spill-out decks on the western side, as well as communal areas consisting of a first-floor recreational space, outdoor sports deck on the street facing façade, a kitchen, laundry, and a breakfast patio and new ablution facility on the southern side (see Figure 5.3.4).

The first floor is accessible by means of a staircase and platform lift (see Figures 5.3.17 to 5.3.30). The design of the staircase balustrade and balcony balustrade (see Figures 5.3.20 to 5.3.27) were inspired by the decorative form of the veranda columns of 19 Tulleken Street. The first-floor space is equipped with a bar, lounge, games area, and balcony, with the outcome of providing a recreational space for both visitors and locals (see Figure 5.3.33). The visual curiosity sparked by seeing the first floor being used will generate interest and interaction.

To provide favourable thermal conditions on the first floor, the Chromadek roof structure is insulated with 100mm Isover insulation and an

Isoboard ceiling (refer to Appendix C for calculations). The glass pane facing West is shaded with vertical wooden louvres, and cross ventilation is achieved through window louvres in the northern and southern glass sections.

Due to the sensitive nature of the heritage structure, precast reinforced concrete slabs were chosen as the floor of the first-floor addition (see Figure 5.3.11), also ensuring that there are no acoustic concerns from the bedrooms below. A wood-look vinyl floor finish with acoustic properties, from the Gerflor Taralay Impressions Comfort range will assist with sound reverberation in the first-floor area.

STAIRCASE APPROACH:

THE COMPONENT

WOOD & STEEL COMBINATION

SCREENING DEVICE  
(HIDE PLATFORM  
LIFT)

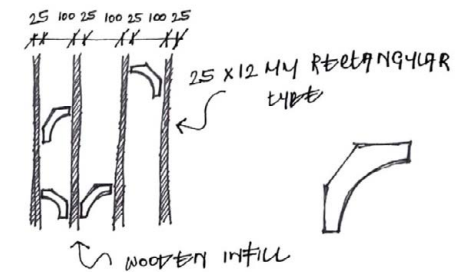
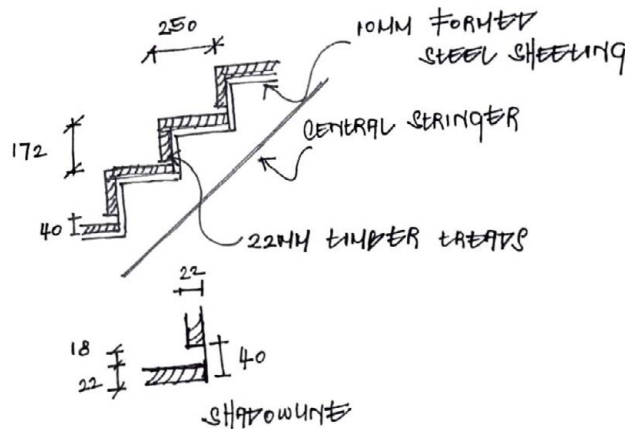
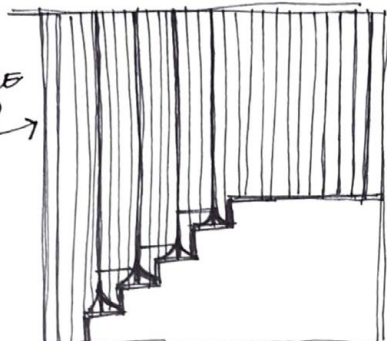
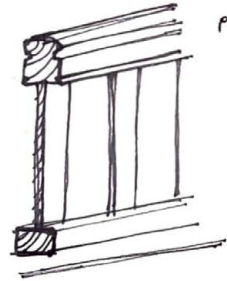
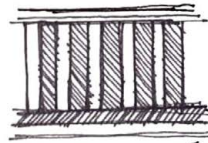
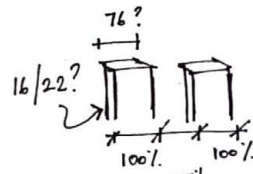


Figure 5.3.20: Conceptual development of the staircase (Author 2017)

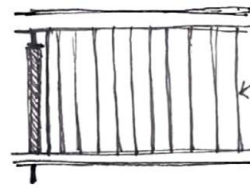
BALUSTRADE ON 19 TULLEKEN STR:



PAINTED WOODEN  
BALUSTRADE



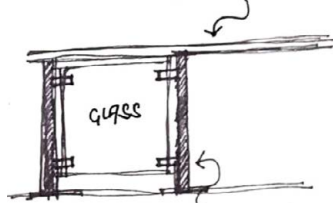
GAP  
CONCRETE  
PUNDT



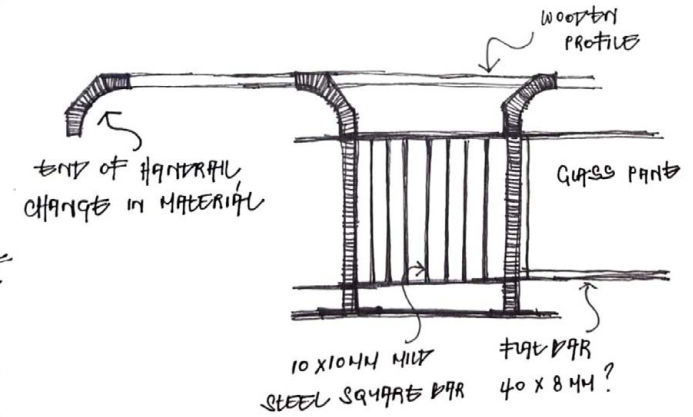
50  
WOODEN  
HANDRAIL  
40

25 X 25 MM SQUARE  
TYPE SLATS.

WOODEN TOPRAIL



GLASS  
RECTANGULAR  
TUBING

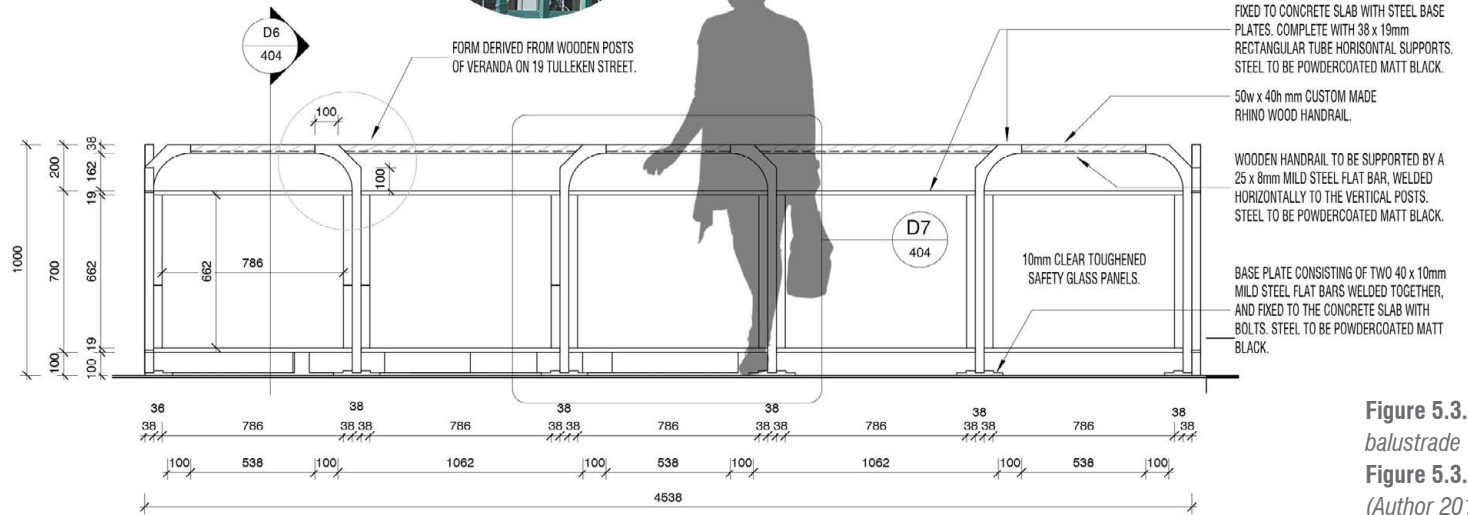


WOODEN  
POSTS  
END OF HANDRAIL  
CHANGE IN MATERIAL

10 X 10 MM MILD  
STEEL SQUARE POST  
40 X 8 MM?



FORM DERIVED FROM WOODEN POSTS  
OF VERANDA ON 19 TULLEKEN STREET.



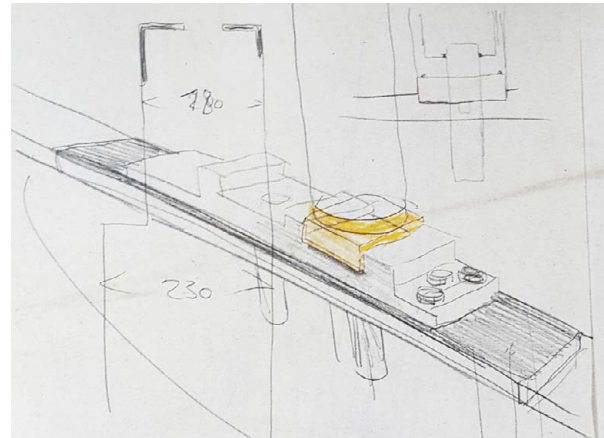
BALUSTRADE ELEVATION

Figure 5.3.21: Conceptual development of the balustrade (Author 2017)

Figure 5.3.22: Balustrade elevation, not to scale (Author 2017)



5.3.23



5.3.24

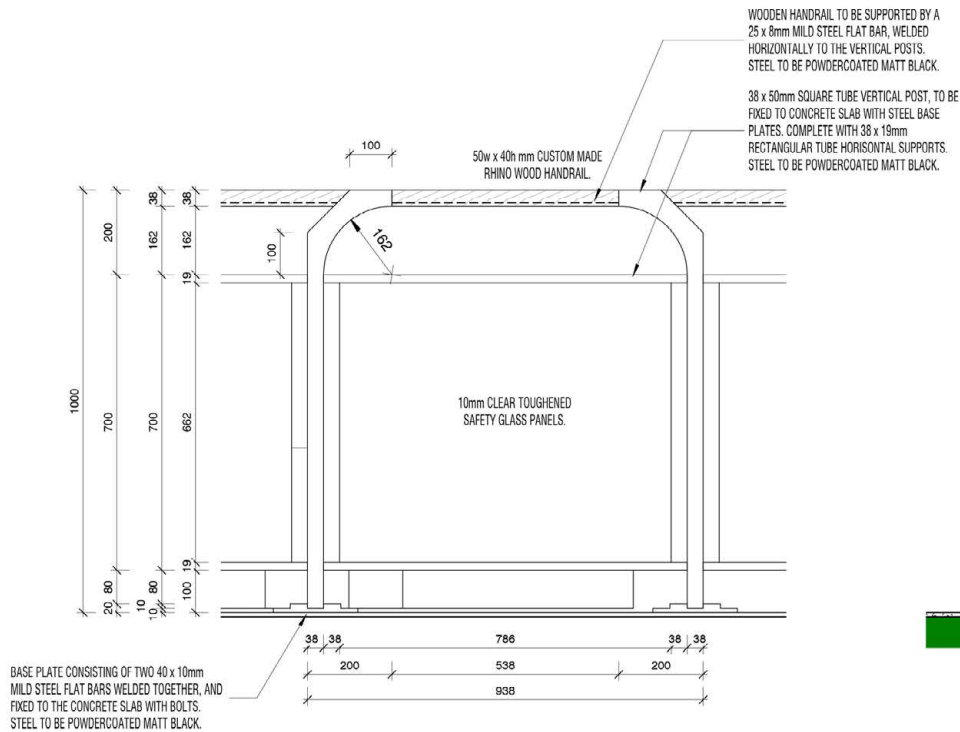
**Figure 5.3.23:** Entrance bridge to the Querini Stampalia Foundation, Venice (Mimoa 2017)

**Figure 5.3.24:** Fixing detail by Carlo Scarpa (Albertini and Bagnoli 1988:61)

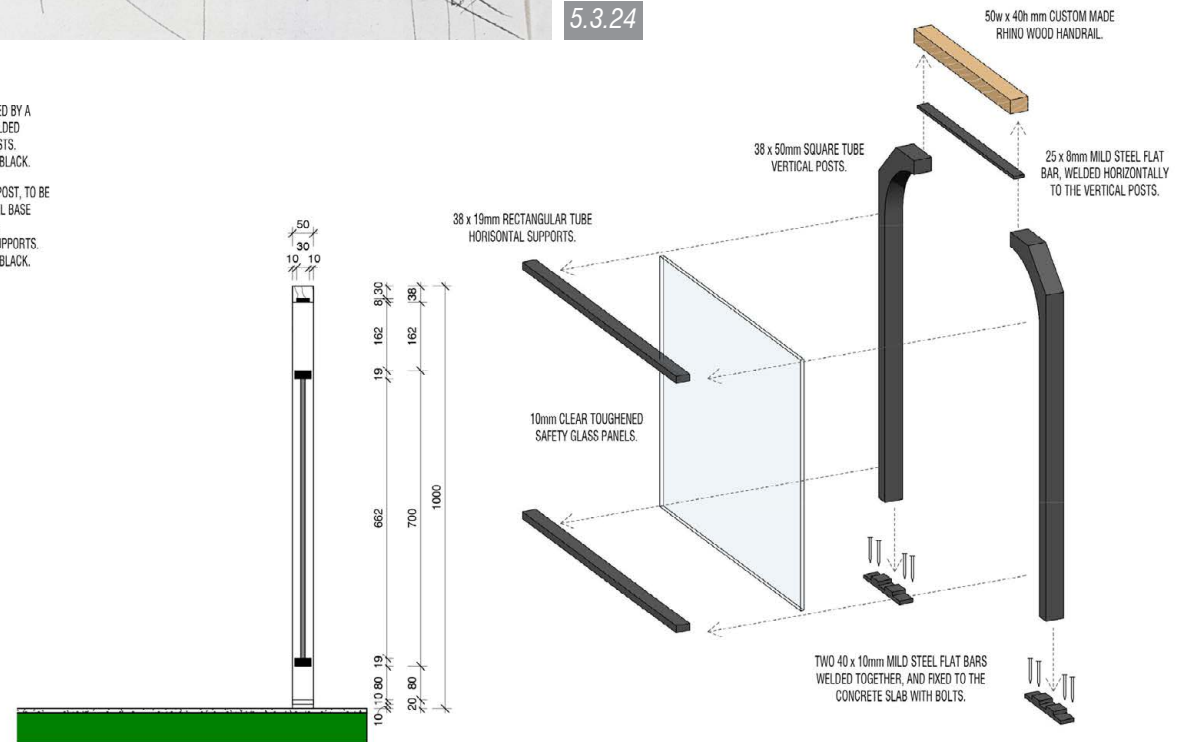
**Figure 5.3.25:** Balustrade detail elevation (Author 2017)

**Figure 5.3.26:** Balustrade detail section (Author 2017)

**Figure 5.3.27:** Exploded axonometric balustrade view (Author 2017)

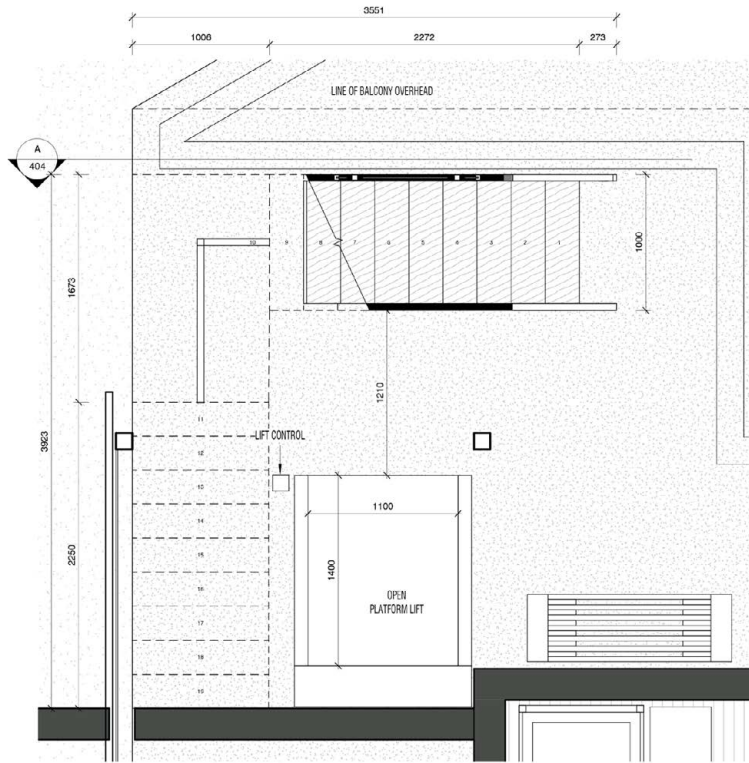


BALUSTRADE DETAIL ELEVATION

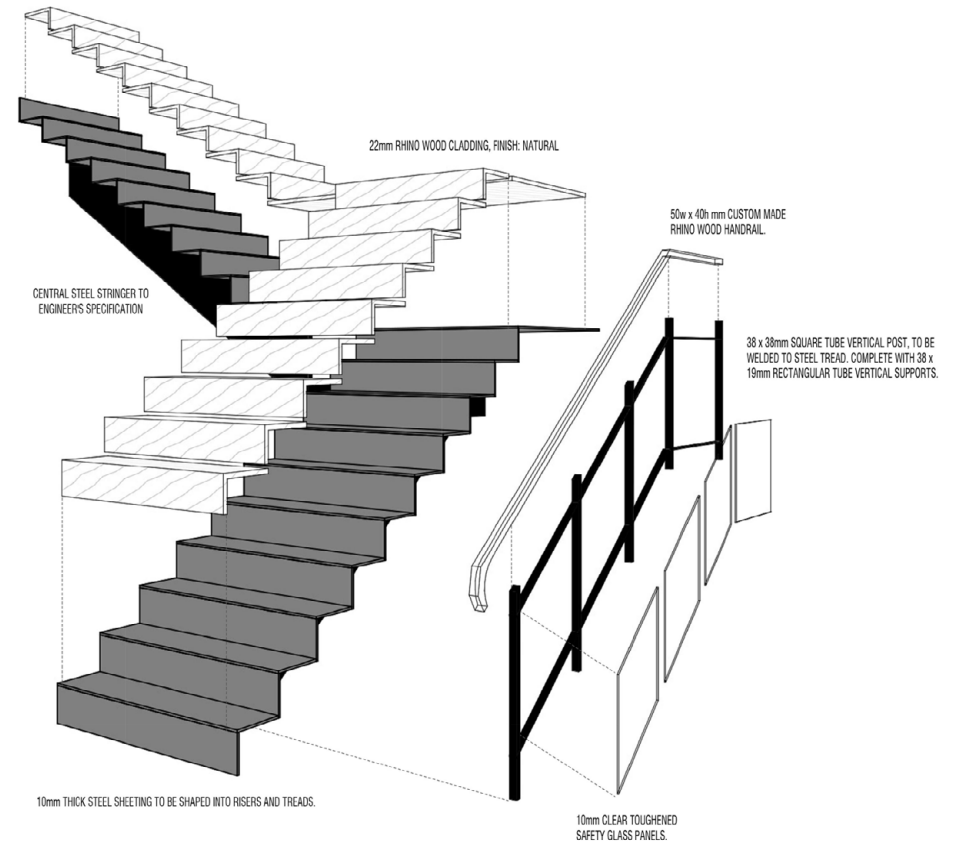


BALUSTRADE DETAIL SECTION

EXPLODED AXONOMETRIC BALUSTRADE VIEW



YOUTH HOSTEL STAIRCASE AND PLATFORM LIFT LAYOUT PLAN



EXPLODED AXONOMETRIC VIEW OF THE STAIRCASE

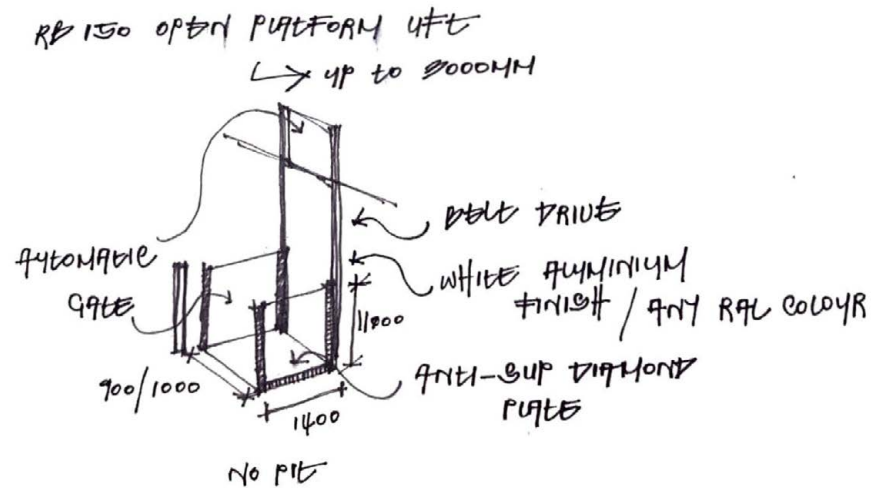
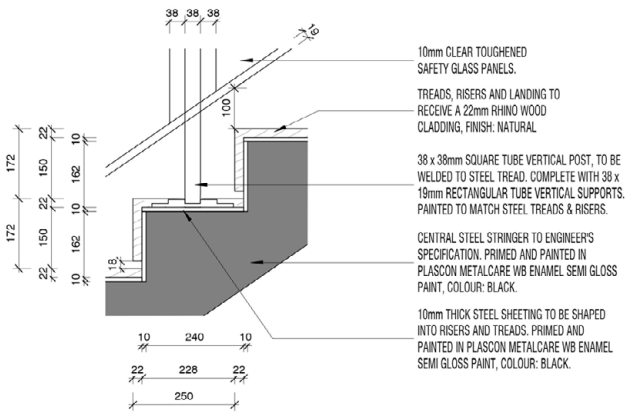


Figure 5.3.28: Youth hostel staircase and platform lift layout plan, not to scale (Author 2017)

Figure 5.3.29: Exploded axonometric view of the staircase (Author 2017)

Figure 5.3.30: The RB 150 open platform lift (Author 2017)

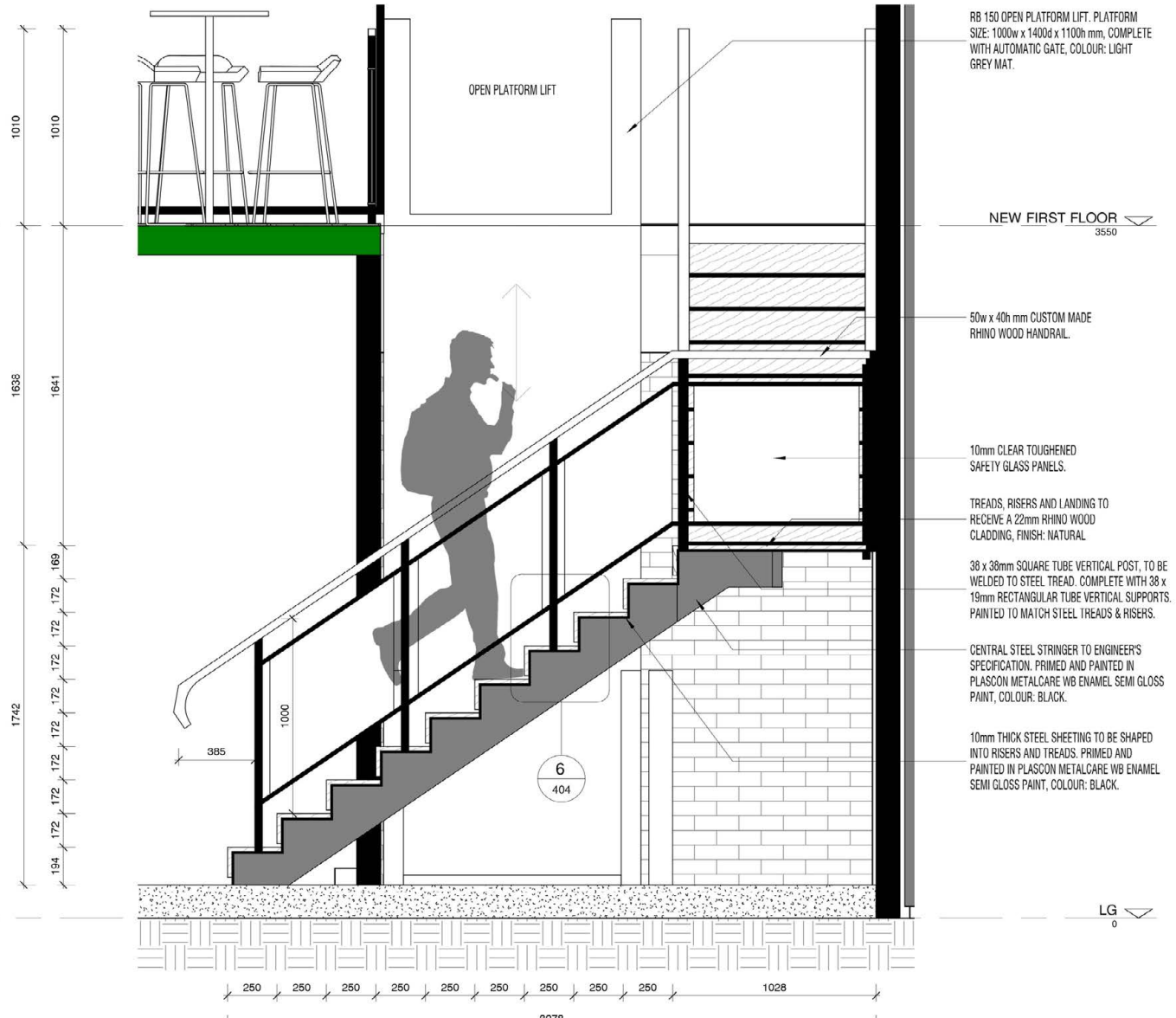


DETAIL 6

Figure 5.3.31: Staircase detail, not to scale (Author 2017)

Figure 5.3.32: Staircase elevation, not to scale (Author 2017)

Figure 5.3.33: Youth hostel first floor interior perspective (Author 2017)



STAIRCASE ELEVATION A





### 5.3.10 TOURIST CENTRE RECEPTION: DESIGN AND RESOLUTION

For the creation of the tourist centre in 19 Tulleken Street, the existing heritage façade and main entrance are preserved. The preservation is substantiated by the precious heritage fabric located at the front and core of the house (refer back to Figure 2.1.58). To enable the flow of movement, new openings are created in the existing walls leading to the NZASM exhibition located to the East of the reception, and the tourist information office located to the West (refer to Figure 5.3.4). The size of these openings is determined by the proportions of the existing window openings in the exhibition and information office.

The existing wooden front door was a later addition to the house, and is replaced with a hinged glass door installed in relation to the stained-glass windows (see Figure 5.3.38).

The reception area is fitted with a reception counter, the design drawing inspiration from the existing floor materials. Grooves are cut into the counter's 12mm white DuPont Corian facing panel, that mimics the layout pattern of the natural stone floor tiles. The horizontal top is constructed from 44mm solid white oak wood, a contemporary reinterpretation of the solid timber floor planks in the adjoining spaces.

Even though 19 Tulleken Street does not have any original pressed metal ceilings, the concept is repeated above the counter as a visual link to the pressed ceilings in the youth hostel. The new panels are suspended above the counter, with backlit LED strip lights, and left unpainted as an contemporary interpretation.



5.3.34

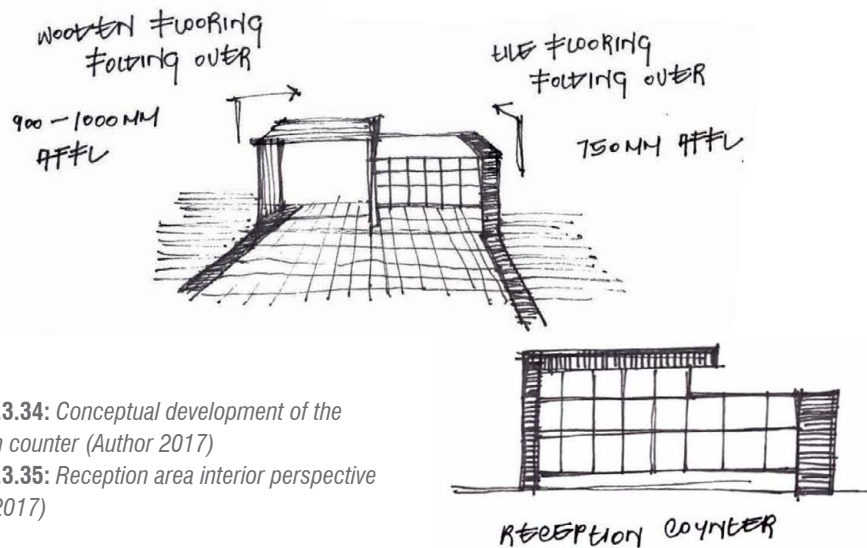
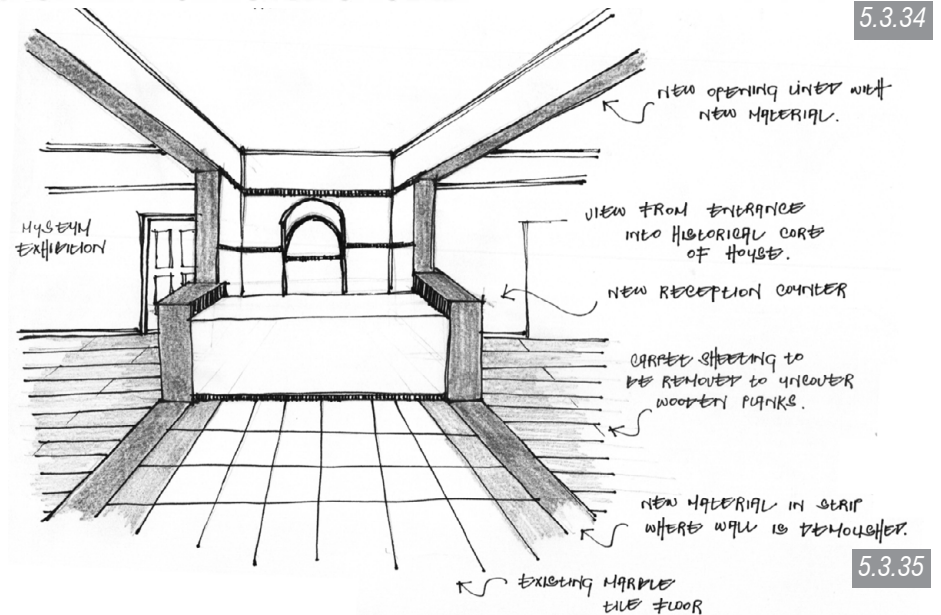
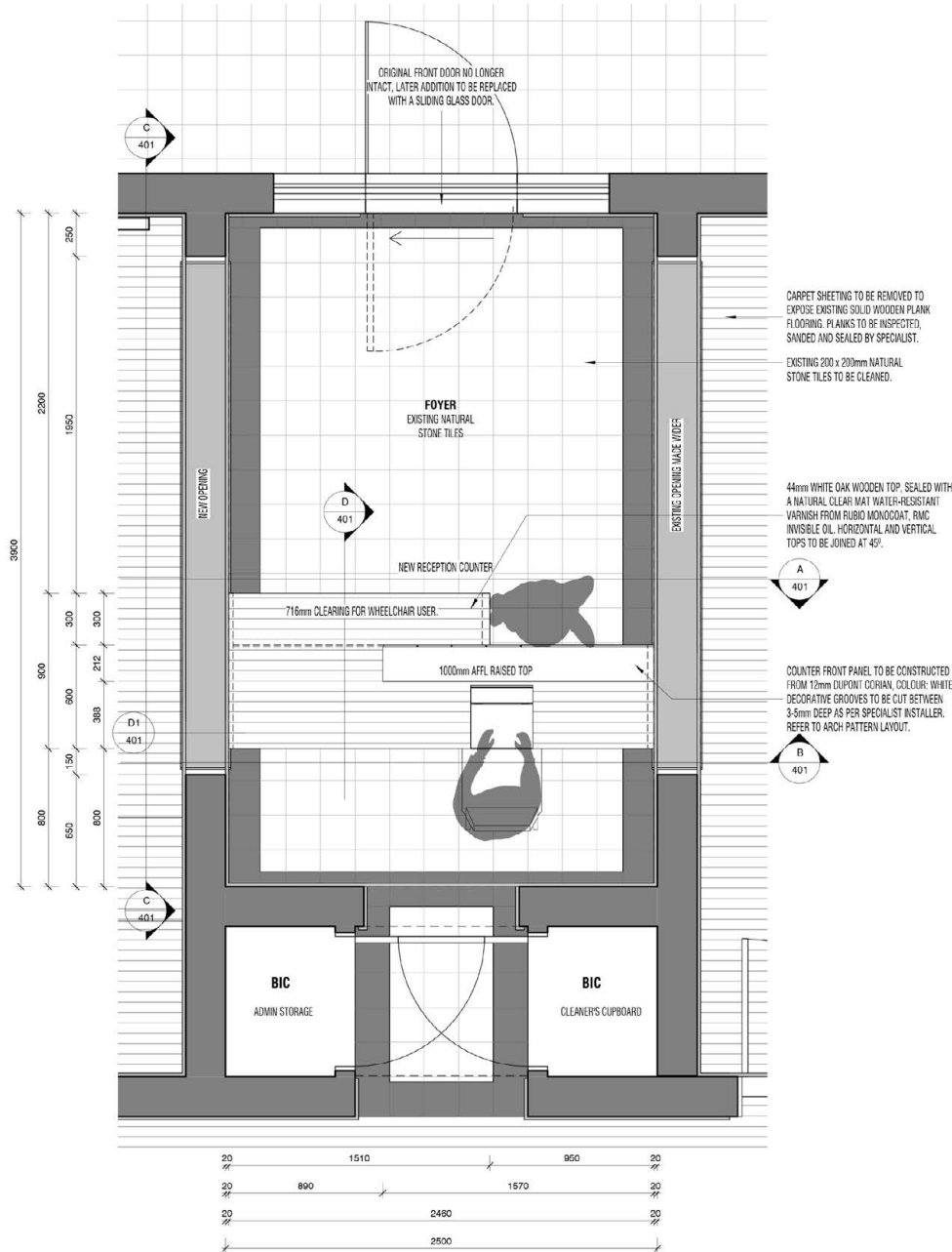


Figure 5.3.34: Conceptual development of the reception counter (Author 2017)

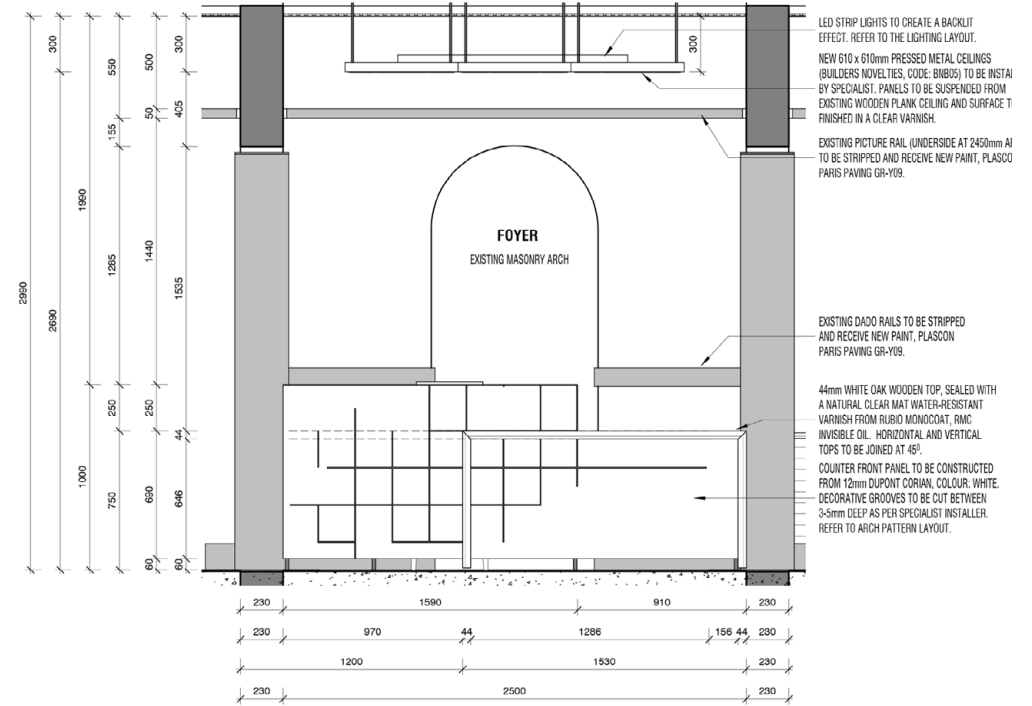
Figure 5.3.35: Reception area interior perspective (Author 2017)



5.3.35



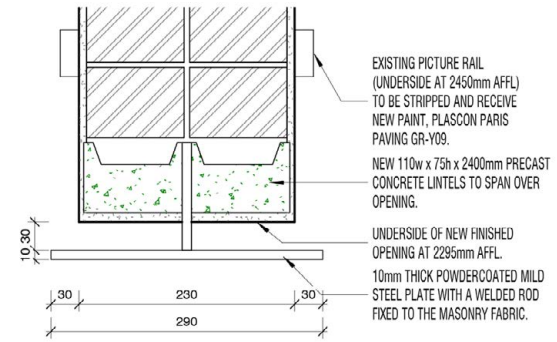
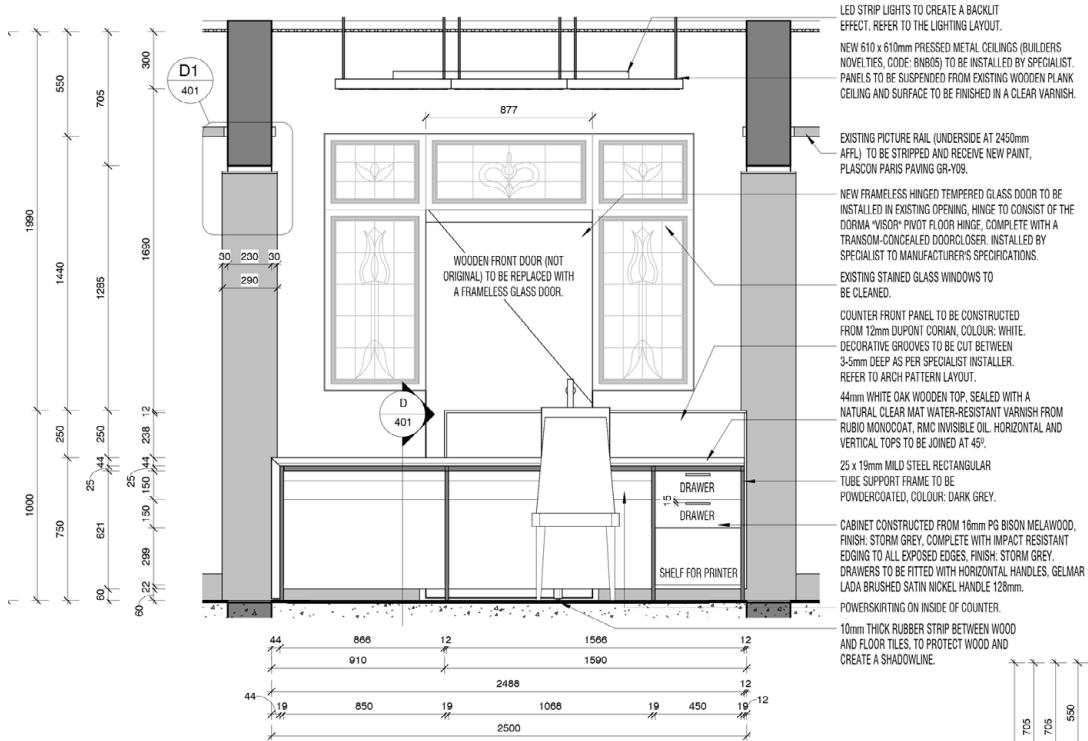
RECEPTION DETAIL LAYOUT PLAN



RECEPTION COUNTER SECTION A

Figure 5.3.36: Reception detail layout plan, not to scale (Author 2017)

Figure 5.3.37: Reception counter Section A, not to scale (Author 2017)



DETAIL SECTION 1

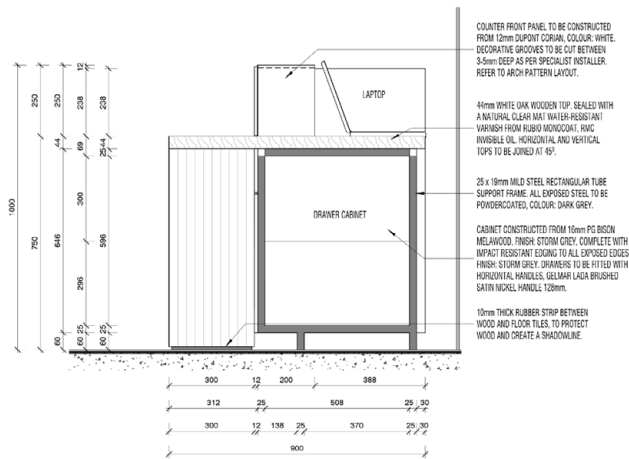
RECEPTION COUNTER SECTION B

Figure 5.3.38: Reception counter Section B, not to scale (Author 2017)

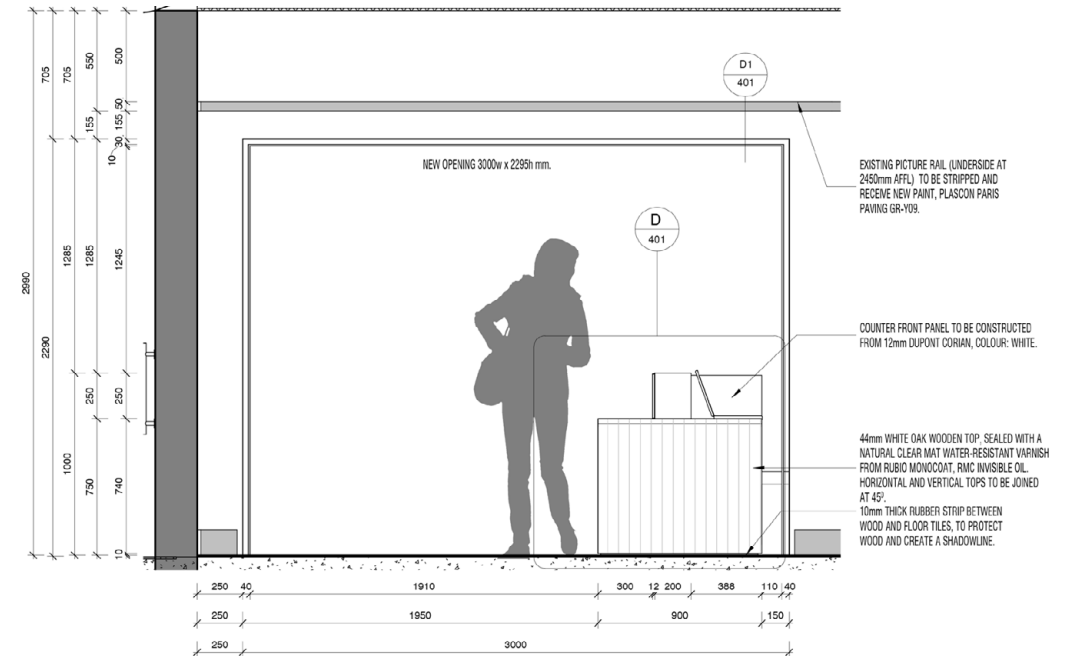
Figure 5.3.39: Reception counter Section C, not to scale (Author 2017)

Figure 5.3.40: Reception counter Section D, not to scale (Author 2017)

Figure 5.3.41: Detail Section 1, not to scale (Author 2017)



RECEPTION COUNTER SECTION D



RECEPTION COUNTER SECTION C

### 5.3.11 THE NZASM EXHIBITION: DESIGN AND RESOLUTION

The exhibition, located in the tourist centre in 19 Tulleken Street tells the story of the establishment of the NZASM, the railway workers and their houses, specifically relatable to the houses in Tulleken Street. The exhibition system aims to be simple in design and materiality, to prevent interfering with the view of the room itself, where features like the wooden fireplace, wooden plank flooring, skirtings, dado rails and picture rails form part of the exhibition and create a sense of the historic.

Models of the NZASM houses are displayed on a clear Plexiglas surface, with information and images printed on canvas and presented in a suspended frame. A new bulkhead with reinforced hangers accommodates the suspended installation

of the information panels and a new dedicated lighting layout.

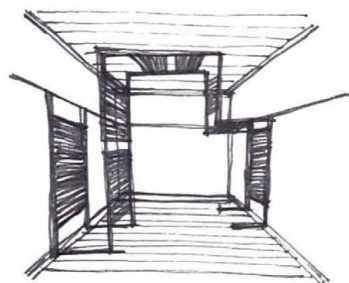
In order to allow more natural light to enter the space and facilitate a visual link with the public realm, a new opening is created and fitted with a fixed glass pane window in an aluminium frame (see Figure 5.3.51). The dimensions of the opening take the position of the skirting, picture rail (2450mm AFFL to underside), brick courses and the proportioning of the existing window box (1800mm wide) in the room into account for the height and width (1800w x 1955h mm). The same concept is mirrored in the tourist office.



Figure 5.3.42: Conceptual development of the exhibition system (Author 2017)

Figure 5.3.43: Exhibition space interior perspective (Author 2017)

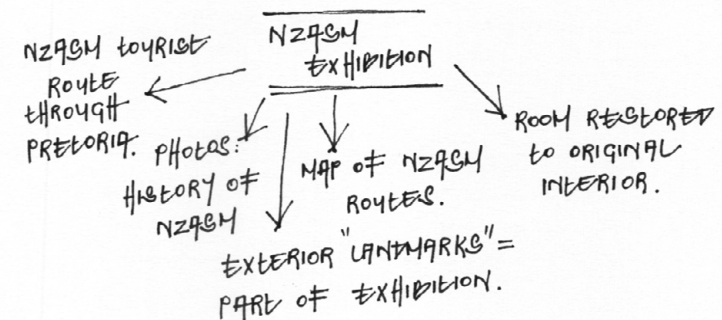
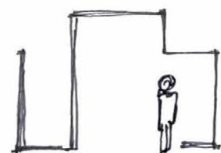
Diagram 5.3.1: Conceptual idea regarding the contents of the exhibition (Author 2017)

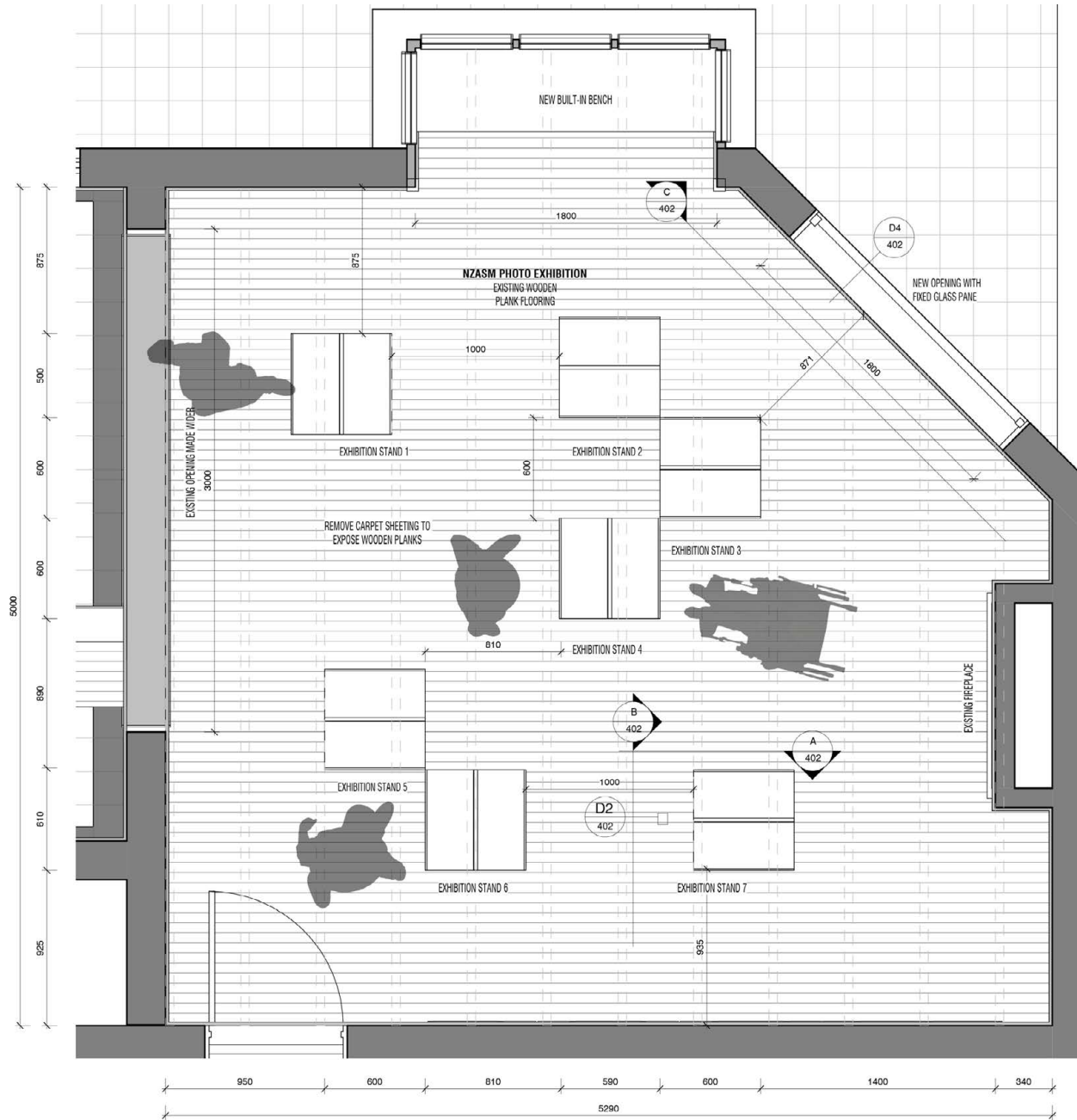


MAIN FEATURES OF SPACE:

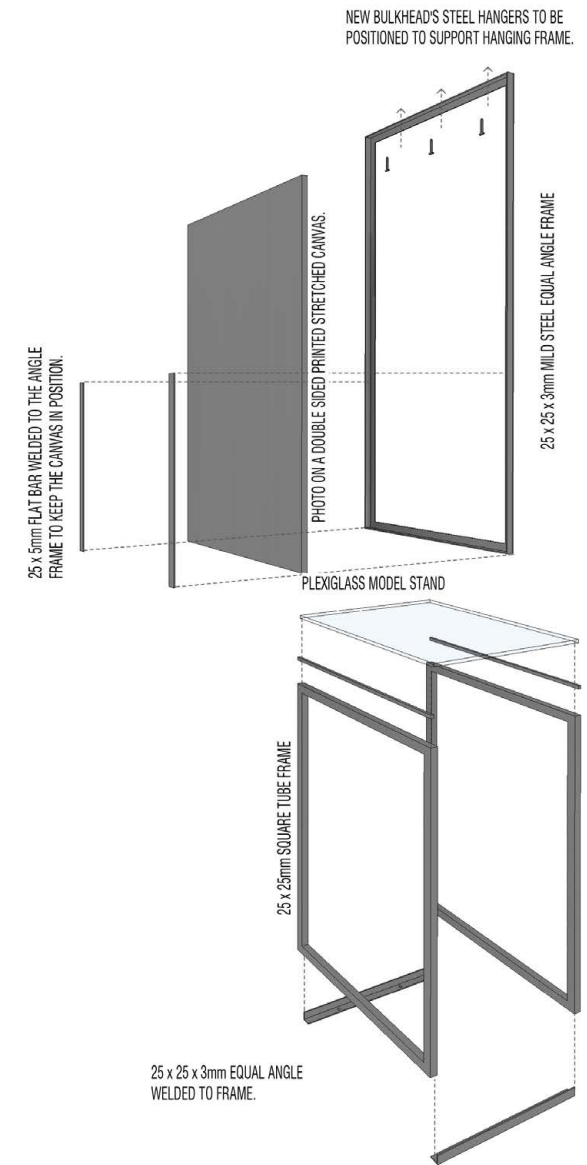
- x WOODEN FLOOR PLANKS
- x PAINTED WOODEN CEILING
- x PICTURE RAIL
- x SKIRTING
- x CORNICE

FRAMEWORK TO HOUSE PHOTO EXHIBITION.





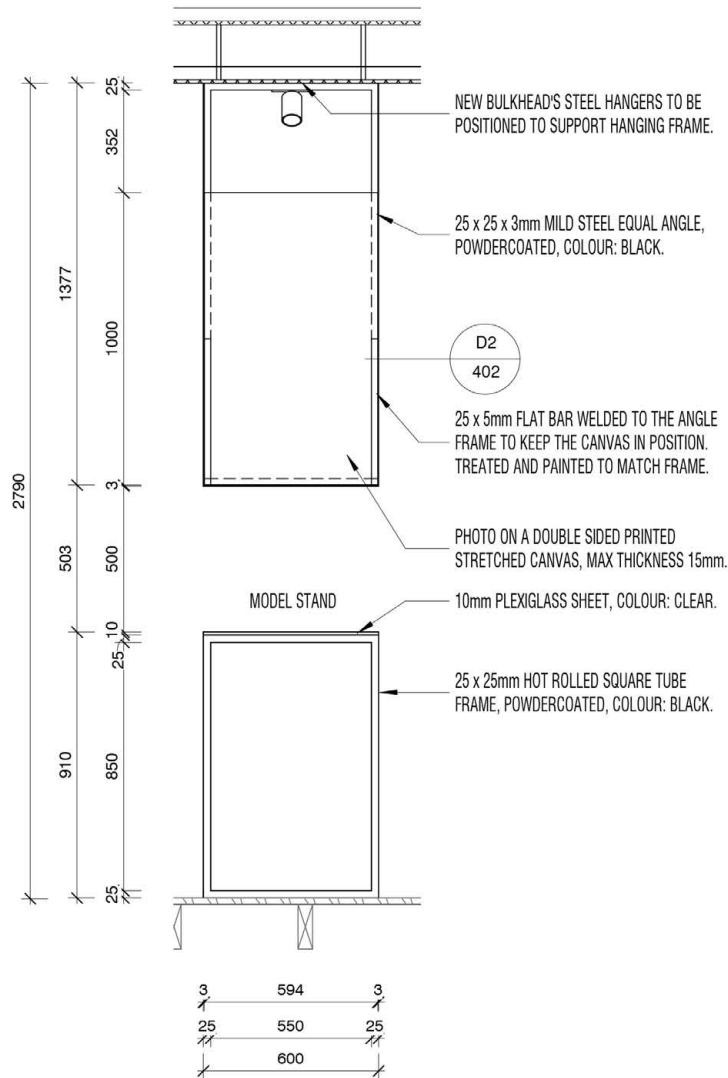
EXHIBITION DETAIL LAYOUT PLAN



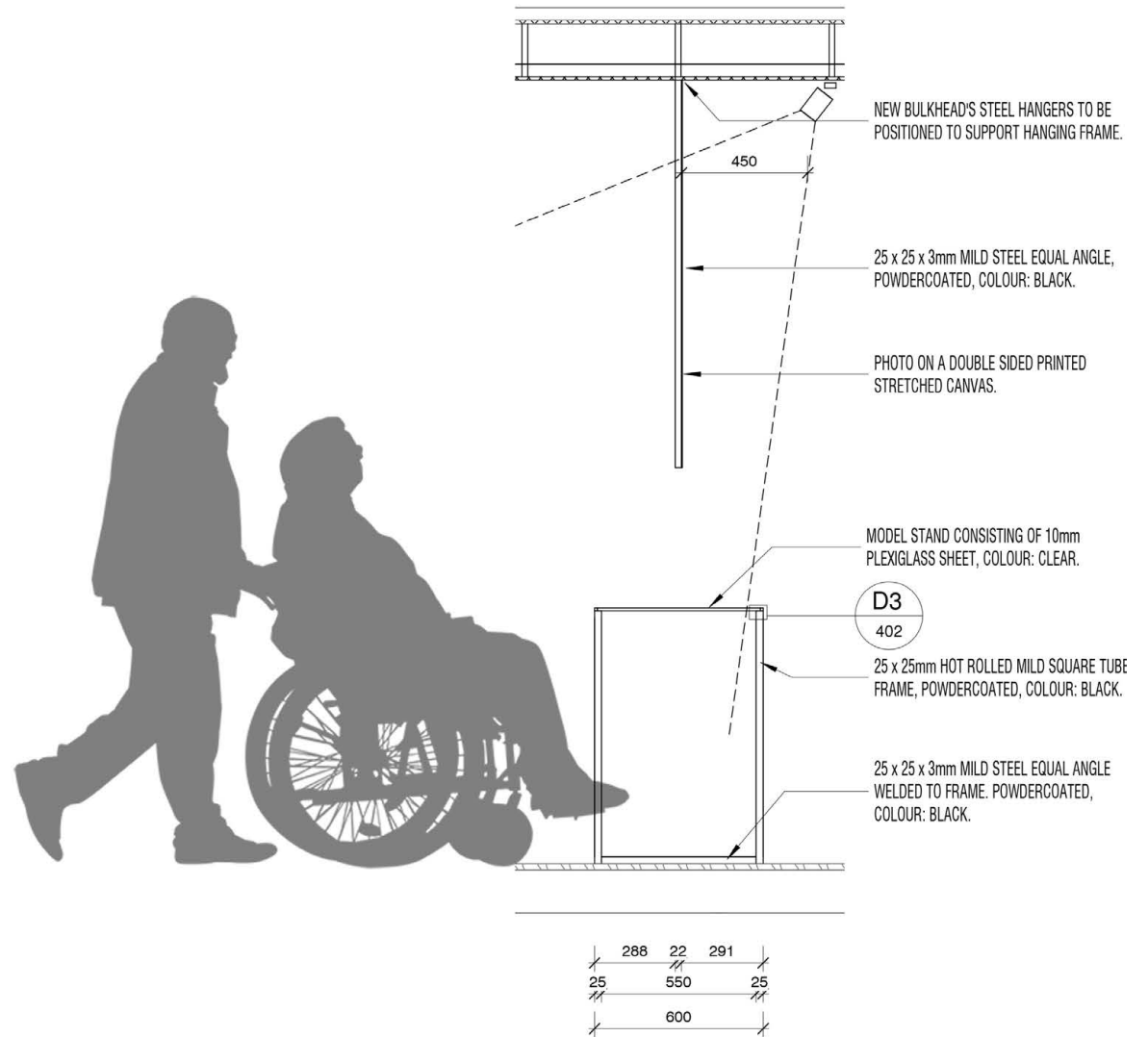
EXPLODED AXONOMETRIC OF AN EXHIBITION STAND

Figure 5.3.44: Exhibition detail layout plan, not to scale (Author 2017)

Figure 5.3.45: Exploded axonometric view of an exhibition stand (Author 2017)



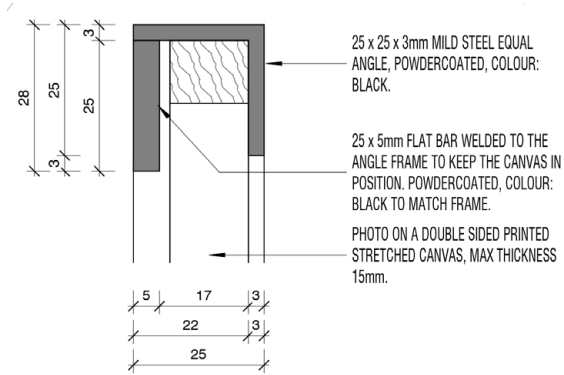
EXHIBITION STAND SECTION A



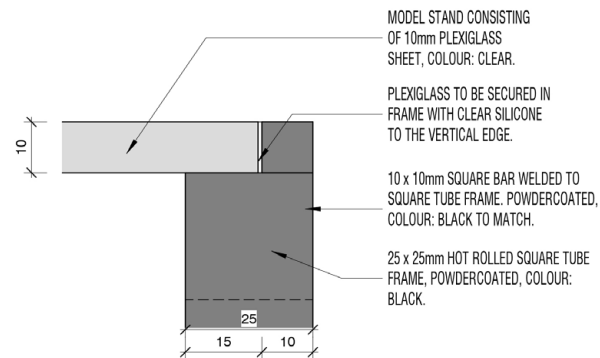
EXHIBITION STAND SECTION B

Figure 5.3.46: Exhibition stand Section A, not to scale (Author 2017)

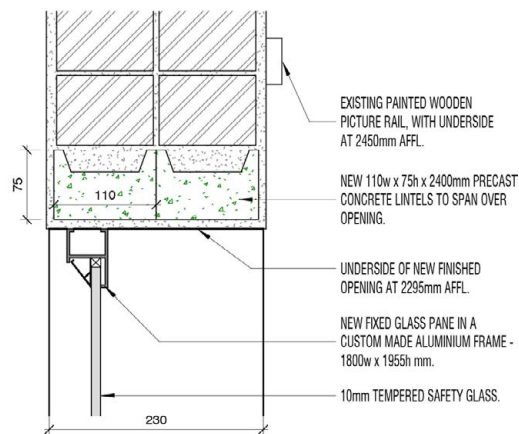
Figure 5.3.47: Exhibition stand Section B, not to scale (Author 2017)



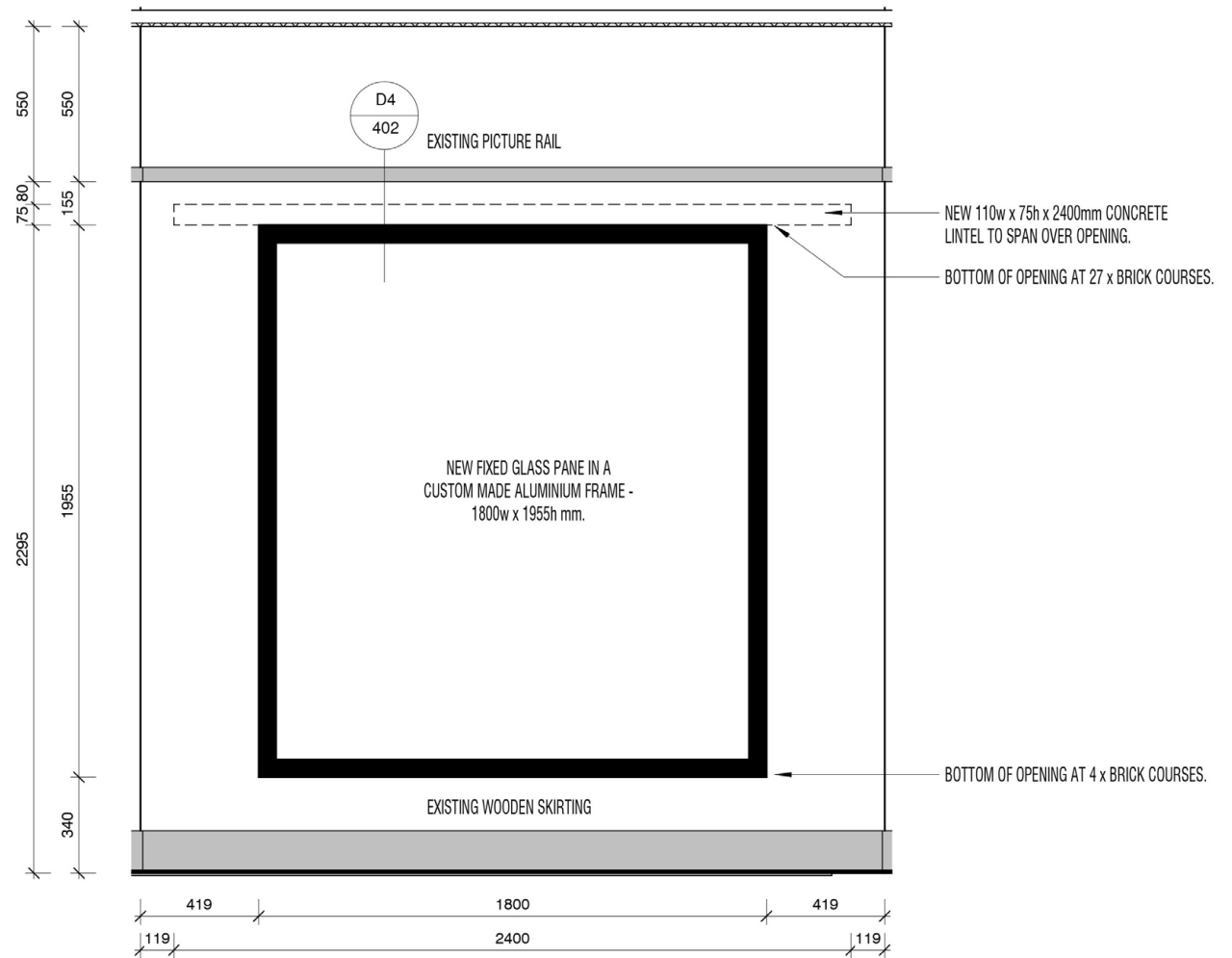
EXHIBITION STAND DETAIL SECTION 2



EXHIBITION STAND DETAIL SECTION 3



NEW WINDOW OPENING DETAIL SECTION 4



NEW WINDOW OPENING SECTION C

Figure 5.3.48: Exhibition stand Detail Section 2, not to scale (Author 2017)

Figure 5.3.49: Exhibition stand Detail Section 3, not to scale (Author 2017)

Figure 5.3.50: New window opening Detail Section 4, not to scale (Author 2017)

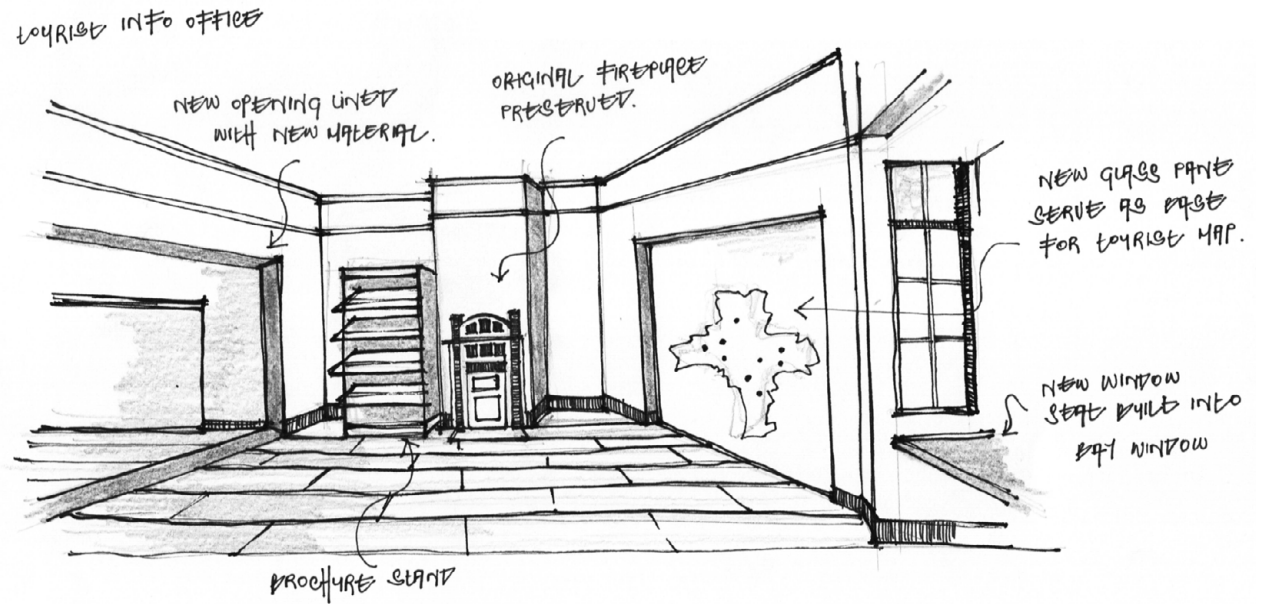
Figure 5.3.51: New window opening Section C, not to scale (Author 2017)



### 5.3.12 THE TOURIST INFORMATION OFFICE: DESIGN AND RESOLUTION

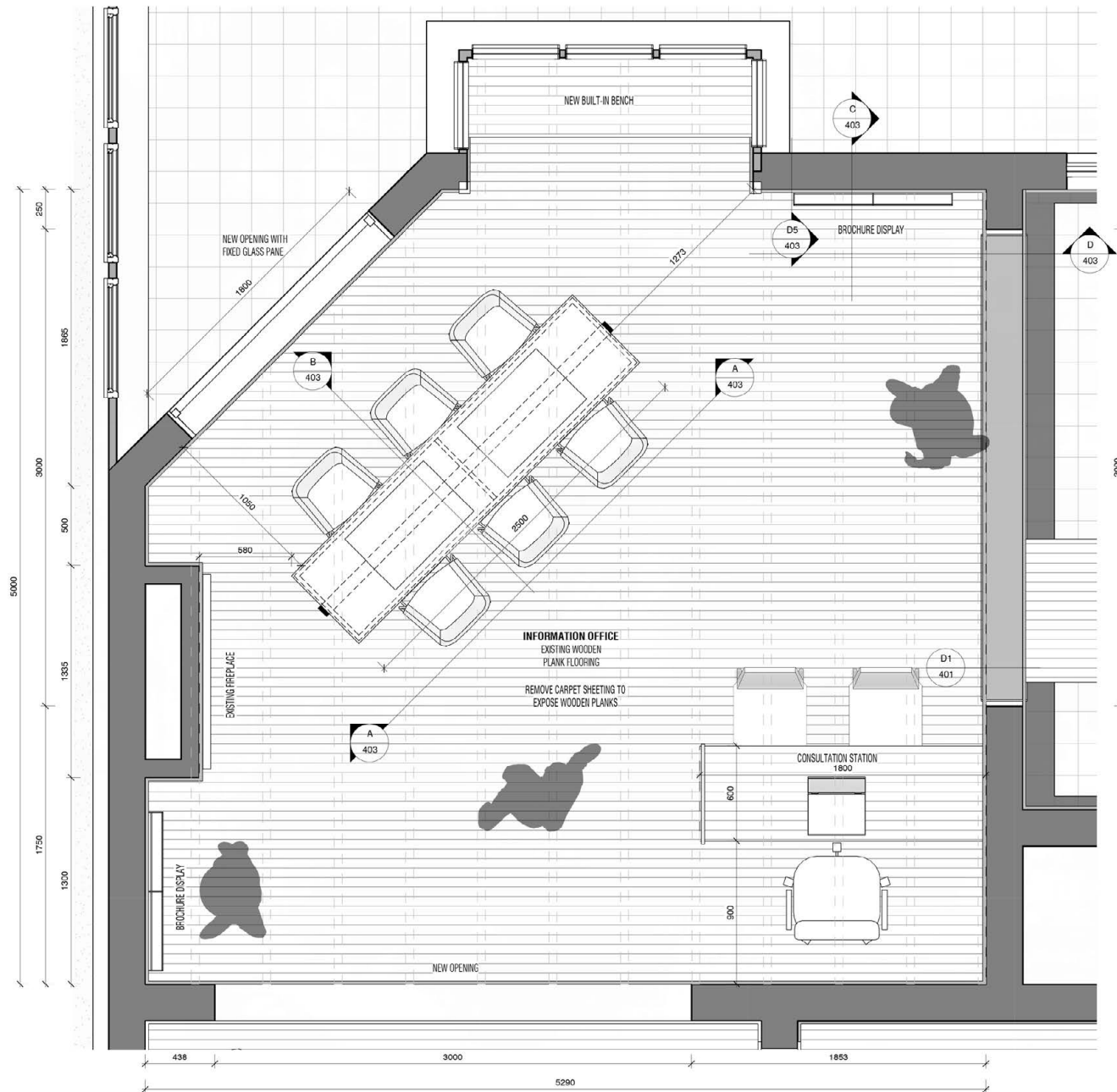
The information office, located in the tourist centre in 19 Tulleken Street is aimed at assisting visitors with information regarding attractions in the precinct and larger Tshwane, and arranging access to the attractions. The office is equipped with a dedicated consultation station, as well as a self-help kiosk. The structure of the kiosk consists of a rectangular steel frame, from which electrical power is carried down from the ceiling to the touch screen monitors installed in a white 12mm DuPont Corian top (see Figures 5.3.55 – 5.3.57).

Two wall mount brochure stands are designed to conceptually make use of the existing picture rail, while blending in with a base of Supawood painted to match the wall (see Figures 5.3.58 to 5.3.61). A visitor would move from the tourist information office to the restaurant reception and curio display.

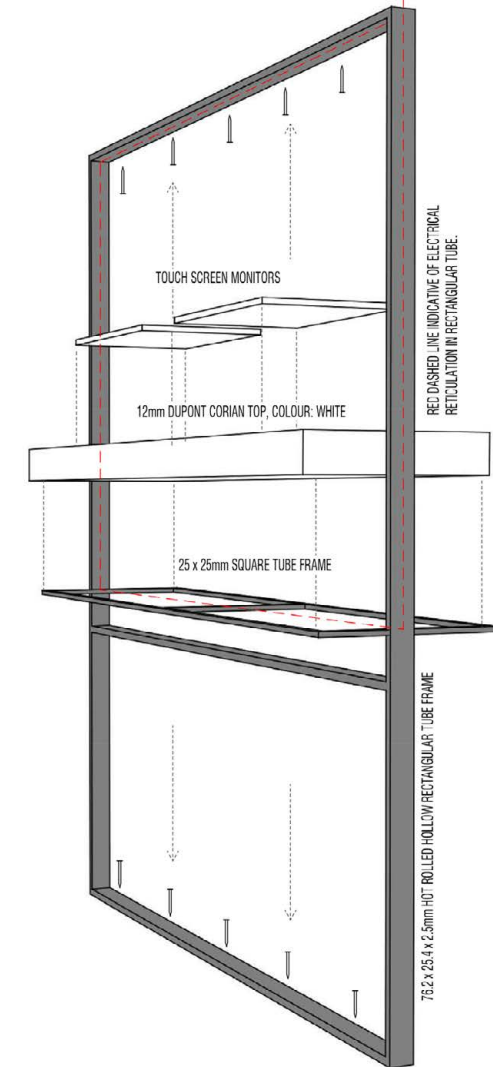


**Figure 5.3.52:** Conceptual development of the information office (Author 2017)

**Figure 5.3.53:** Information office interior perspective (Author 2017)



INFORMATION OFFICE DETAIL LAYOUT PLAN

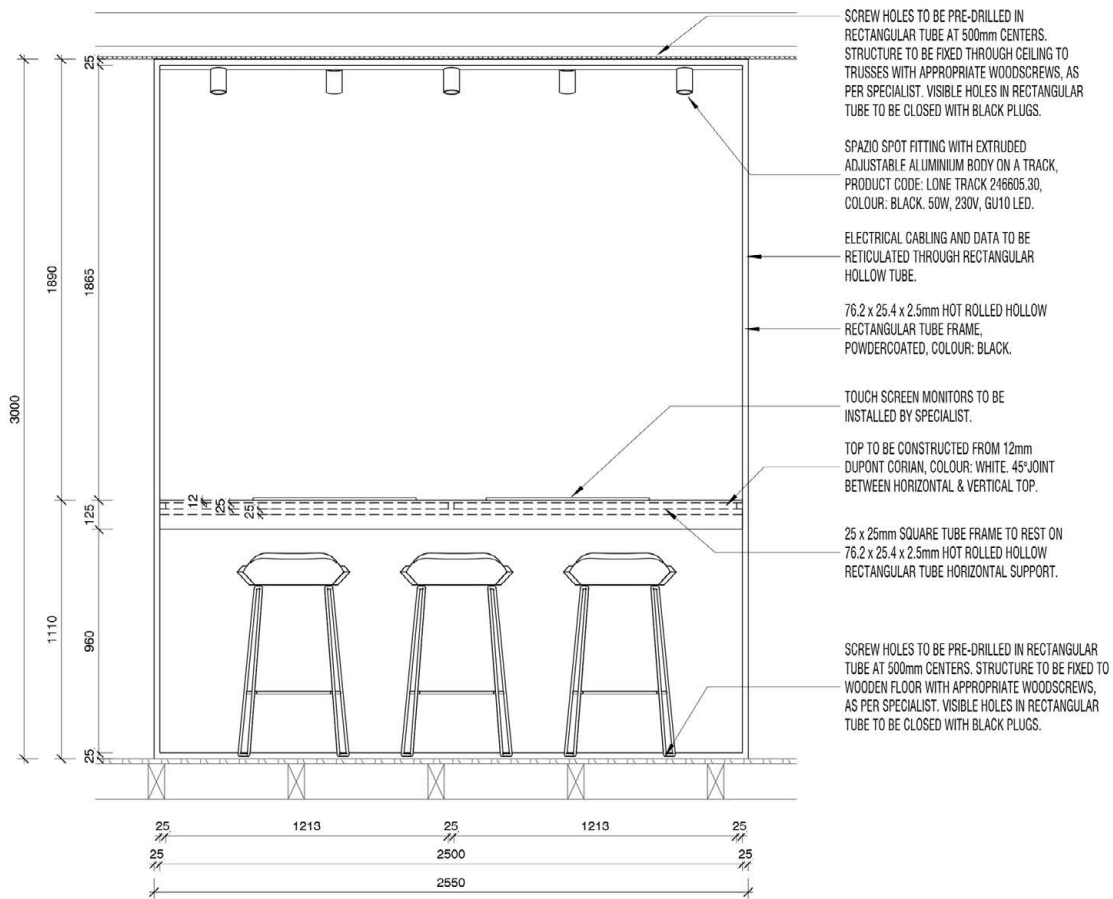


STRUCTURE TO BE FIXED TO WOODEN FLOOR WITH APPROPRIATE WOODSCREWS THROUGH PRE-DRILLED HOLES.

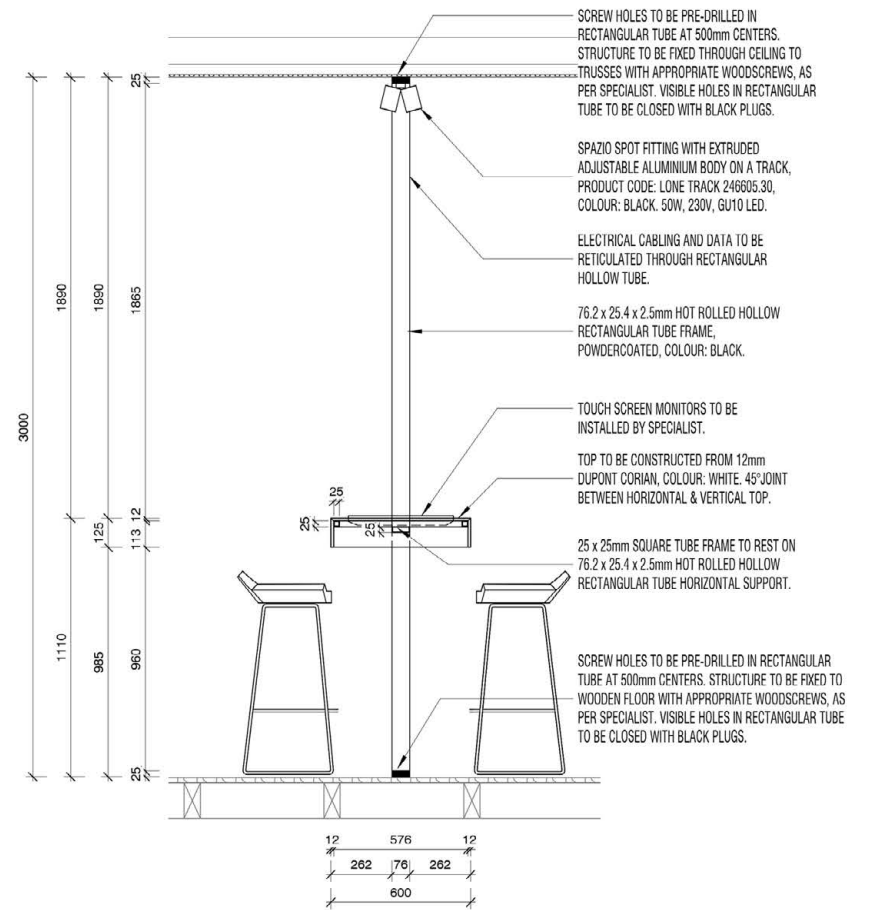
EXPLODED AXONOMETRIC OF SELF-HELP KIOSK

Figure 5.3.54: Information office detail layout plan, not to scale (Author 2017)

Figure 5.3.55: Exploded axonometric view of the self-help kiosk (Author 2017)



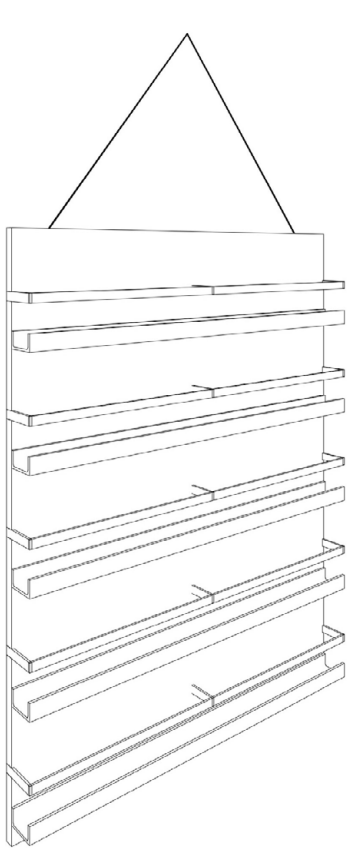
SELF-HELP KIOSK SECTION A



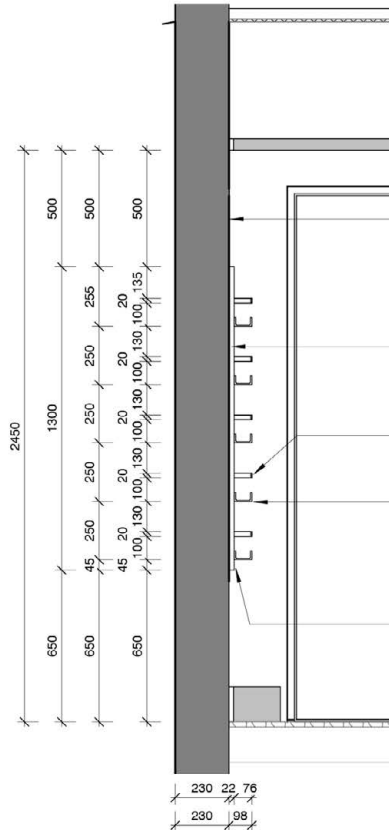
SELF-HELP KIOSK SECTION B

Figure 5.3.56: Self-help kiosk Section A, not to scale (Author 2017)

Figure 5.3.57: Self-help kiosk Section B, not to scale (Author 2017)



BROCHURE DISPLAY VIEW



STEEL CABLE TO BE FIXED TO THE EXISTING PICTURE RAIL TO CREATE THE ILLUSION THAT THE BOARD IS SUSPENDED FROM THE RAIL.

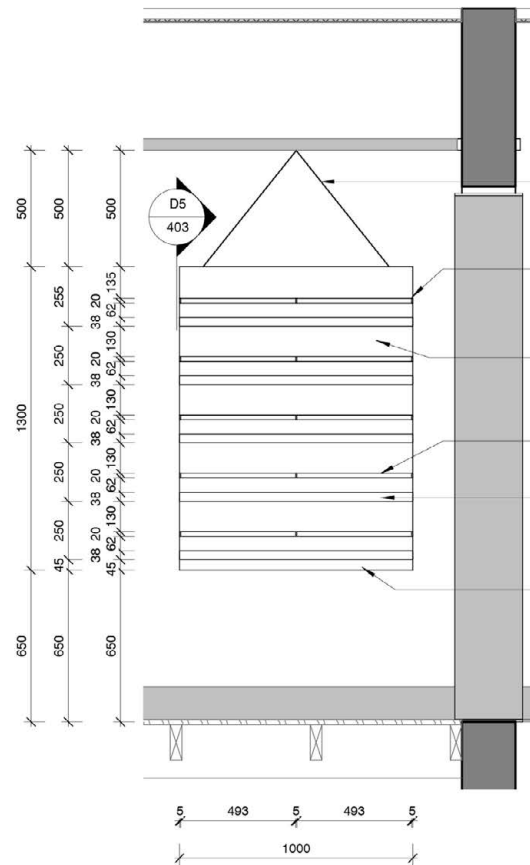
SUPAWOOD TO BE FITTED TO EXISTING MASONRY WALL WITH COUNTERSUNK SCREWS. OPENINGS TO BE FINISHED WITH WOODFILLER PRIOR TO PAINTWORK.

20 x 5mm FLATBAR TO BE POWDERCOATED OFF SITE, COLOUR: BLACK.

76 x 38mm TAPER FLANGE STEEL CHANNEL TO BE POWDERCOATED OFF SITE, COLOUR: BLACK.

22mm PG BISON SUPAWOOD TO BE PAINTED TO MATCH THE WALL, PLASCON OFF SHORE GR-Y03.

BROCHURE DISPLAY SECTION C



STEEL CABLE TO BE FIXED TO THE EXISTING PICTURE RAIL TO CREATE THE ILLUSION THAT THE BOARD IS SUSPENDED FROM THE RAIL.

20 x 5mm OPENING TO BE CUT IN SIDE OF SUPAWOOD TO ACCOMMODATE FLATBAR. TO BE FIXED WITH ADHESIVE AS PER SPECIALIST.

SUPAWOOD TO BE FITTED TO EXISTING MASONRY WALL WITH COUNTERSUNK SCREWS. OPENINGS TO BE FINISHED WITH WOODFILLER PRIOR TO PAINTWORK.

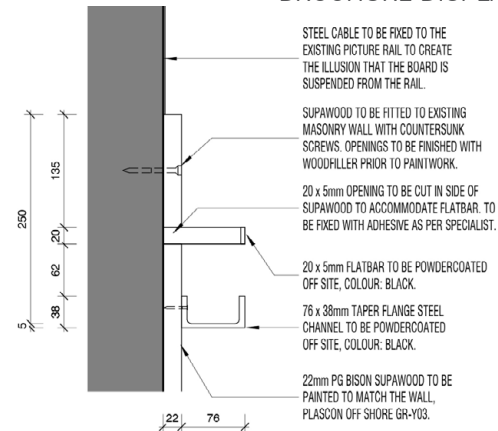
20 x 5mm FLATBAR TO BE POWDERCOATED OFF SITE, COLOUR: BLACK.

76 x 38mm TAPER FLANGE STEEL CHANNEL TO BE POWDERCOATED OFF SITE, COLOUR: BLACK.

22mm PG BISON SUPAWOOD TO BE PAINTED TO MATCH THE WALL, PLASCON OFF SHORE GR-Y03.

BROCHURE DISPLAY SECTION D

BROCHURE DISPLAY DETAIL 5



STEEL CABLE TO BE FIXED TO THE EXISTING PICTURE RAIL TO CREATE THE ILLUSION THAT THE BOARD IS SUSPENDED FROM THE RAIL.

SUPAWOOD TO BE FITTED TO EXISTING MASONRY WALL WITH COUNTERSUNK SCREWS. OPENINGS TO BE FINISHED WITH WOODFILLER PRIOR TO PAINTWORK.

20 x 5mm OPENING TO BE CUT IN SIDE OF SUPAWOOD TO ACCOMMODATE FLATBAR. TO BE FIXED WITH ADHESIVE AS PER SPECIALIST.

20 x 5mm FLATBAR TO BE POWDERCOATED OFF SITE, COLOUR: BLACK.

76 x 38mm TAPER FLANGE STEEL CHANNEL TO BE POWDERCOATED OFF SITE, COLOUR: BLACK.

22mm PG BISON SUPAWOOD TO BE PAINTED TO MATCH THE WALL, PLASCON OFF SHORE GR-Y03.

Figure 5.3.58: Brochure display view (Author 2017)

Figure 5.3.59: Brochure display Section C, not to scale (Author 2017)

Figure 5.3.60: Brochure display Section D, not to scale (Author 2017)

Figure 5.3.61: Brochure display Detail section 5, not to scale (Author 2017)

### 5.3.13 RECEPTION, NZASM EXHIBITION AND TOURIST INFORMATION OFFICE CEILING PLAN AND LIGHTING LAYOUT

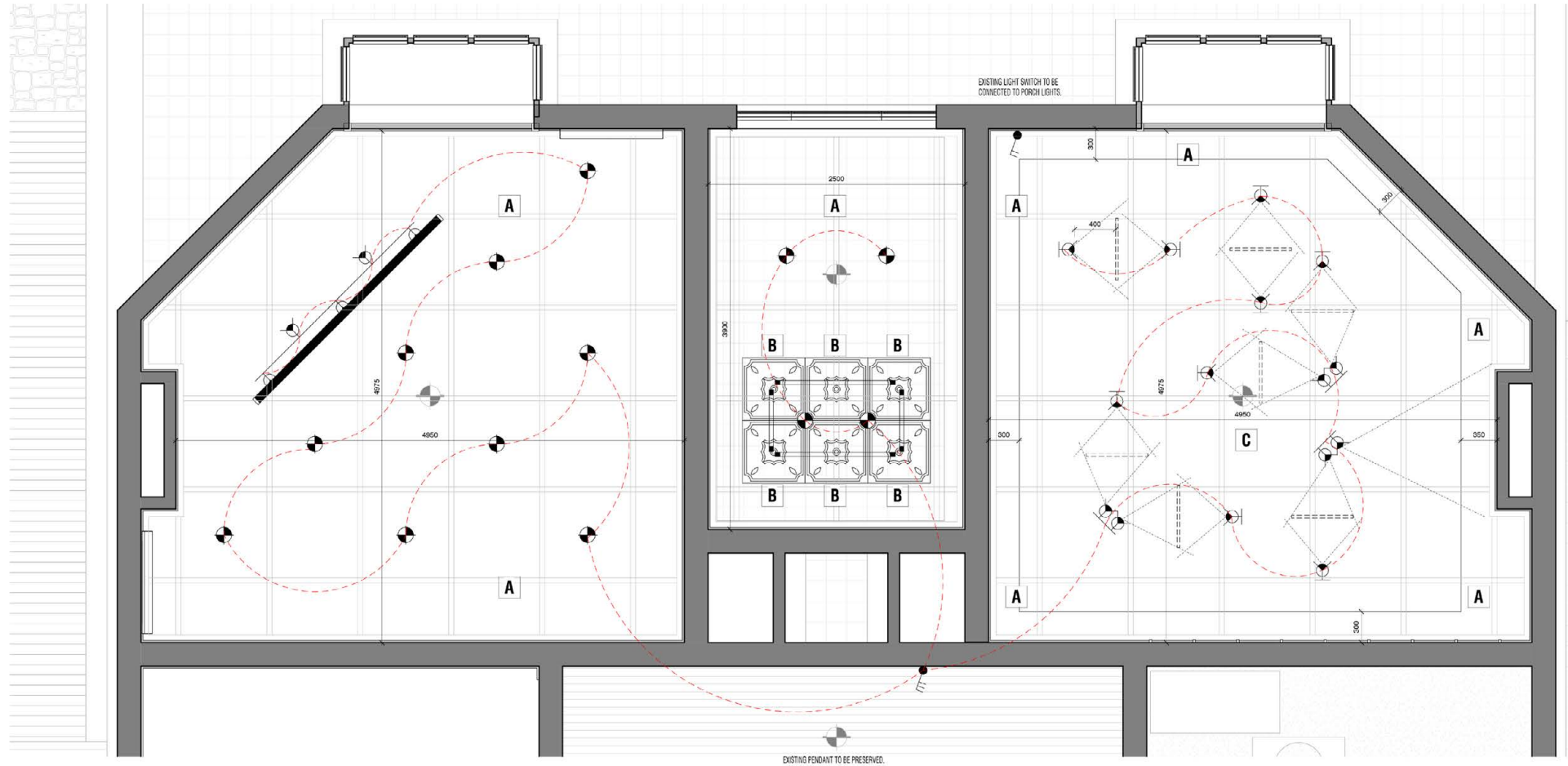


Figure 5.3.62: Reflected ceiling plan and lighting layout, not to scale (Author 2017)

CEILING LEGEND	
<b>A</b>	EXISTING PLASTERBOARD CEILING WITH EXPOSED GRID TO BE PROTECTED DURING CONSTRUCTION, CLEANED, PREPARED AND PAINTED IN PLASCON DOUBLE VELVET PAINT, COLOUR: BRILLIANT WHITE. PAINTWORK TO PLASCON SPECIFICATIONS. EXISTING CORNICE TO BE PRESERVED AND PAINTED.
<b>B</b>	NEW 610 x 610mm PRESSED METAL CEILINGS (BUILDERS NOVELTIES, CODE: BNB05) TO BE INSTALLED BY SPECIALIST. PANELS TO BE SUSPENDED FROM EXISTING WOODEN PLANK CEILING AND SURFACE TO BE FINISHED IN A CLEAR VARNISH.
<b>C</b>	BULKHEAD: NEW PATENT SUSPENDED CEILING GRID SYSTEM BY SPECIALISTS FOR 9,5mm GYPSUM CEILING BOARDS WITH RHINOLITE SKIM PLASTER AND PAINT FINISH (PAINTED IN PLASCON DOUBLE VELVET PAINT, COLOUR: BRILLIANT WHITE. PAINTWORK TO PLASCON SPECIFICATIONS). UNDERSIDE OF BULKHEAD: 2790mm AFFL.  HANGERS TO BE REINFORCED TO ACCOMMODATE THE WEIGHT OF THE SUSPENDED EXHIBITION SYSTEM.

5.3.1

Table 5.3.1: Ceiling legend (Author 2017)

Table 5.3.2: Lighting legend (Author 2017)

ELECTRICAL LEGEND		
		EXISTING GLASS PENDANT TO BE REMOVED. OPENING TO BE CLOSED TO A SMOOTH SURFACE AND PAINTED TO MATCH EXISTING.  EXCEPTION: PENDANT IN THE CORRIDOR TO BE PRESERVED.
		NEW CEILING DOWNLIGHT: PHAROX LED 120 DIA. DOWNLIGHT DIMMABLE 230V, 6500K, 10W, 670 LUMEN, 35 000 HOURS. ALUMINIUM POWDERCOATED WHITE, TILTABLE HOUSING.  <a href="http://www.pharox.co.za/prod/premium-range/commercial-lighting/item/40-pharox-led-4-downlight.html">http://www.pharox.co.za/prod/premium-range/commercial-lighting/item/40-pharox-led-4-downlight.html</a>
		STRIP LIGHT: RADIANT PRODUCT CODE: LED 137: LED TUBE 9W 600mm 4500K 720LUMEN LED 138: LED TUBE 18W 1200mm 4500K 1400LUMEN (POWERED FROM ONE SIDE). LIGHTS TO BE INSTALLED ON TOP OF SUSPENDED CEILING TO CREATE A DIFFUSED BACKLIT EFFECT.  <a href="https://www.radiant.co.za/Prod_pics/_530/LED134.jpg">https://www.radiant.co.za/Prod_pics/_530/LED134.jpg</a>
		SPAZIO SPOT FITTING WITH EXTRUDED ADJUSTABLE ALUMINIUM BODY, PRODUCT CODE: LONE SQUARE 246611.30, COLOUR: BLACK. 50W, 230V, GU10 LED.    <a href="http://shop.spazio.co.za/product/1365/lone-square/">http://shop.spazio.co.za/product/1365/lone-square/</a>
		SPAZIO SPOT FITTING WITH EXTRUDED ADJUSTABLE ALUMINIUM BODY, PRODUCT CODE: LONE SQUARE 2 LIGHT 246612.30, COLOUR: BLACK. 2 x 50W, 230V, GU10 LED.    <a href="http://shop.spazio.co.za/product/1366/lone-square-2-light/">http://shop.spazio.co.za/product/1366/lone-square-2-light/</a>
		SPAZIO SPOT FITTING WITH EXTRUDED ADJUSTABLE ALUMINIUM BODY ON A TRACK, PRODUCT CODE: LONE TRACK 246605.30, COLOUR: BLACK. 50W, 230V, GU10 LED.    <a href="http://shop.spazio.co.za/product/1231/lone-track/">http://shop.spazio.co.za/product/1231/lone-track/</a>
SPOTLIGHT LAMP		PHAROX 300 GU-10 DOWNLIGHTER NON-DIMMABLE 230V, 4000K (NEUTRAL WHITE) GU10 BASE, 5.5W, 300 LUMEN, 35 000 HOURS. FROSTED LENS.  <a href="http://www.pharox.co.za/prod/premium-range/consumer-lighting.raw?task=download&amp;fid=40">http://www.pharox.co.za/prod/premium-range/consumer-lighting.raw?task=download&amp;fid=40</a>

5.3.2

Average illumination = Total Luminous Flux (LF) x Utilisation Factor (UF) x Maintenance Factor (MF) / Average Working Plane (Awp)

<b>Area A: NZASM Exhibition</b>		<b>Lux required: Museums &amp; art galleries: General = 200, Displays = As per specialist (Table 1, p.26, SANS 10114-1:2005)</b>			
<b>1. Total Luminous Flux</b>	<b>No. of Luminaires</b>	<b>No. of Lamps</b>	<b>Lumens per lamp</b>	<b>Total (No of Luminaires x No of Lamps x Lumens/lamp)</b>	
Spotlight	15	15	300	15 x 15 x 300 = <b>67 500 LM</b>	
<b>2. Utilisation Factor (UF)</b>	<b>0,34 (from table)</b>				
<b>Room Index</b>	<b>Room length</b>	<b>Room width</b>	<b>Height (Working plane)</b>	<b>Total ((L x W) / (L + W) x H)</b>	
	4,975m	4,95m	2,79m	(4,975 x 4,95) / (4,975 + 4,95) x 2,79 = 24,63 / 26,44 = <b>0,93</b>	
<b>3. Maintenance Factor (MF)</b>	<b>Lamp Lumen (LLMF)</b>	<b>Lamp Survival Factor (LSF)</b>	<b>Luminaire (LMF)</b>	<b>Room Surface (RSMF)</b>	<b>Total (LLMF x LSF x LMF x RSMF)</b>
Spotlights	0,7 (6000 hours)	1	0,9 (Normal 1 year)	0,91 (Normal 1 year)	0,7 x 1 x 0,9 x 0,91 = <b>0,5733</b>
<b>4. Average Working Plane (Awp)</b>	<b>Working plane length</b>	<b>Working plane width</b>	<b>Total (L x W)</b>		
	4,975m	4,95m	4,975 x 4,95 = <b>24,63m<sup>2</sup></b>		

$$\begin{aligned}
 \text{Average illumination} &= \text{LF} \times \text{UF} \times \text{MF} / \text{Awp} \\
 &= (67\,500 \times 0,34 \times 0,5733) / 24,63 \\
 &= 534,2 \text{ lx}
 \end{aligned}$$

The average illumination of the exhibition is more than the value for general areas described in SANS 10114-1:2005. The spotlights are however specifically placed to illuminate the photo display and model of each exhibition stand.

**Table 5.3.3:** Lighting calculation for Area A: NZASM Exhibition (Author 2017)

Average illumination = Total Luminous Flux (LF) x Utilisation Factor (UF) x Maintenance Factor (MF) / Average Working Plane (Awp)

<b>Area B: Tourist Centre Reception</b>				<b>Lux required: Office: Reception Desk = 300</b> (Table 1, p.27, SANS 10114-1:2005)	
<b>1. Total Luminous Flux</b>	<b>No. of Luminaires</b>	<b>No. of Lamps</b>	<b>Lumens per lamp</b>	<b>Total (No of Luminaires x No of Lamps x Lumens/lamp)</b>	
Downlights	4	4	670	4 x 4 x 670 = 10 720 LM	
600mm Strip Light	2	2	720	2 x 2 x 720 = 2 880 LM	
1200mm Strip Light	2	2	1400	2 x 2 x 1400 = 5 600 LM	
				10 720 + 2 880 + 5 600 = <b>19 200 LM</b>	
<b>2. Utilisation Factor (UF)</b>	<b>0,31</b> (from table)				
<b>Room Index</b>	<b>Room length</b>	<b>Room width</b>	<b>Height (Working plane)</b>	<b>Total ((L x W) / (L + W) x H)</b>	
	3,9m	2,5m	3m	(3,9 x 2,5) / (3,9 + 2,5) x 3 = 9,75 / 19,2 = <b>0,508</b>	
<b>3. Maintenance Factor (MF)</b>	<b>Lamp Lumen (LLMF)</b>	<b>Lamp Survival Factor (LSF)</b>	<b>Luminaire (LMF)</b>	<b>Room Surface (RSMF)</b>	<b>Total (LLMF x LSF x LMF x RSMF)</b>
Downlights	0,7 (6000 hours)	1	0,9 (Normal 1 year)	0,91 (Normal 1 year)	0,7 x 1 x 0,9 x 0,91 = 0,5733
Strip lights	0,7 (6000 hours)	1	0,9 (Normal 1 year)	0,84 (Normal 1 year)	0,7 x 1 x 0,9 x 0,84 = 0,5292
					Total (Average) = <b>0,5513</b>
<b>4. Average Working Plane (Awp)</b>	<b>Working plane length</b>	<b>Working plane width</b>	<b>Total (L x W)</b>		
	3,9m	2,5m	3,9 x 2,5 = <b>9,75m<sup>2</sup></b>		

$$\begin{aligned}
 \text{Average illumination} &= \text{LF} \times \text{UF} \times \text{MF} / \text{Awp} \\
 &= (19\,200 \times 0,31 \times 0,5513) / 9,75 \\
 &= 336,55 \text{ lx}
 \end{aligned}$$

The average illumination of 336,55lx is sufficient for a reception, including the task lighting required on the desk surface, in line with SANS 10114-1:2005.

**Table 5.3.3: Lighting calculation for Area A:**  
 NZASM Exhibition (Author 2017)



Average illumination = Total Luminous Flux (LF) x Utilisation Factor (UF) x Maintenance Factor (MF) / Average Working Plane (Awp)

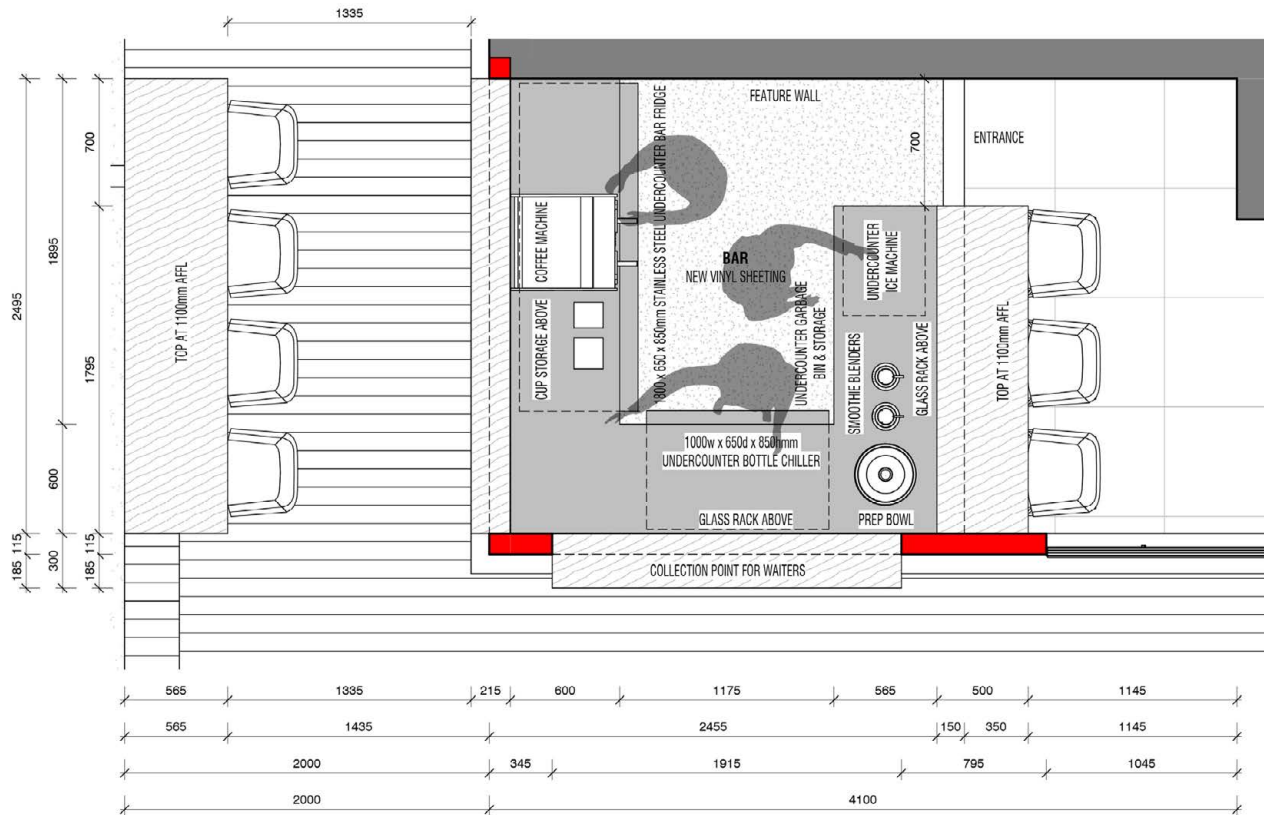
<b>Area C: Tourist Information Office</b>					<b>Lux required: Office: General office = 500</b> (Table 1, p.27, SANS 10114-1:2005)	
<b>1. Total Luminous Flux</b>	<b>No. of Luminaires</b>	<b>No. of Lamps</b>	<b>Lumens per lamp</b>	<b>Total (No of Luminaires x No of Lamps x Lumens/lamp)</b>		
Downlights	9	9	670	9 x 9 x 670 = 54 270 LM		
Spotlights	5	5	300	5 x 5 x 300 = 7 500 LM		
				54 270 + 7 500 = <b>61 770 LM</b>		
<b>2. Utilisation Factor (UF)</b>	<b>0,33</b> (from table)					
<b>Room Index</b>	<b>Room length</b>	<b>Room width</b>	<b>Height (Working plane)</b>	<b>Total ((L x W) / (L + W) x H)</b>		
	4,975m	4,95m	3m	(4,975 x 4,95) / (4,975 + 4,95) x 3 = 24,63 / 29,78 = <b>0,827</b>		
<b>3. Maintenance Factor (MF)</b>	<b>Lamp Lumen (LLMF)</b>	<b>Lamp Survival Factor (LSF)</b>	<b>Luminaire (LMF)</b>	<b>Room Surface (RSMF)</b>	<b>Total (LLMF x LSF x LMF x RSMF)</b>	
Downlights/ Spotlights	0,7 (6000 hours)	1	0,9 (Normal 1 year)	0,91 (Normal 1 year)	0,7 x 1 x 0,9 x 0,91 = <b>0,5733</b>	
<b>4. Average Working Plane (Awp)</b>	<b>Working plane length</b>	<b>Working plane width</b>	<b>Total (L x W)</b>			
	4,975m	4,95m	4,975 x 4,95 = <b>24,63m<sup>2</sup></b>			

$$\begin{aligned}
 \text{Average illumination} &= \text{LF} \times \text{UF} \times \text{MF} / \text{Awp} \\
 &= (61\,770 \times 0,33 \times 0,5733) / 24,63 \\
 &= 474,47 \text{ lx}
 \end{aligned}$$

The average illumination of 474,47lx is close to the required 500lx for general offices, in line with SANS 10114-1:2005. Due to a certain portion of the room functioning as a corridor between the tourist centre reception and restaurant reception, the required illumination can be lowered.

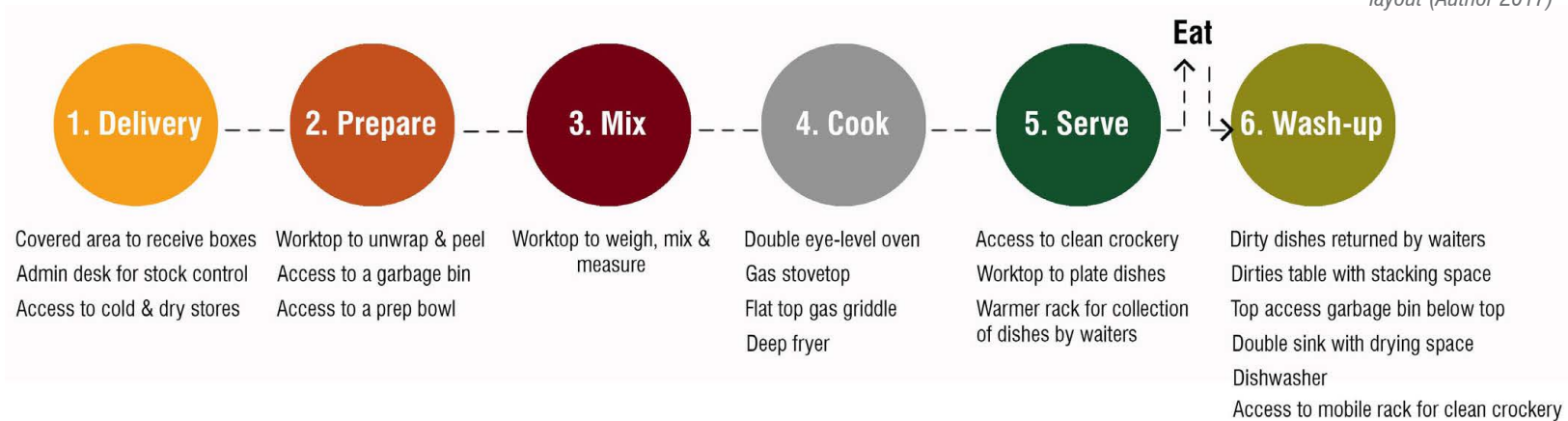
*Table 5.3.5: Lighting calculation for Area C: Tourist Information Office (Author 2017)*

### 5.3.14 RESTAURANT KITCHEN AND BAR



BAR DETAIL LAYOUT

Figure 5.3.63: Bar detail layout (Author 2017)  
Diagram 5.3.2: Kitchen process diagram (Author 2017)  
Figure 5.3.64: Restaurant kitchen detail layout (Author 2017)





RESTAURANT KITCHEN DETAIL LAYOUT

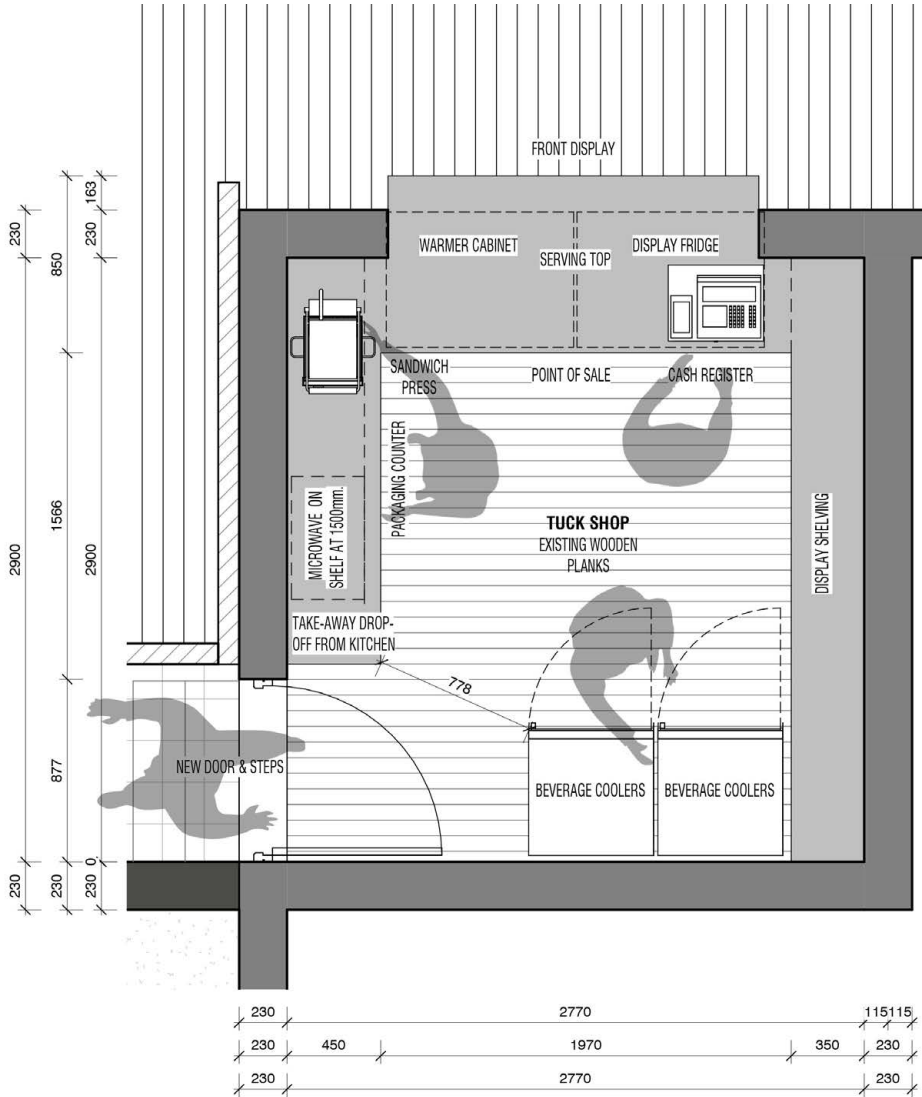
### 5.3.15 TUCKSHOP AND TAKE-AWAYS

Figure 5.3.65: Tuckshop detail layout, not to scale (Author 2017)

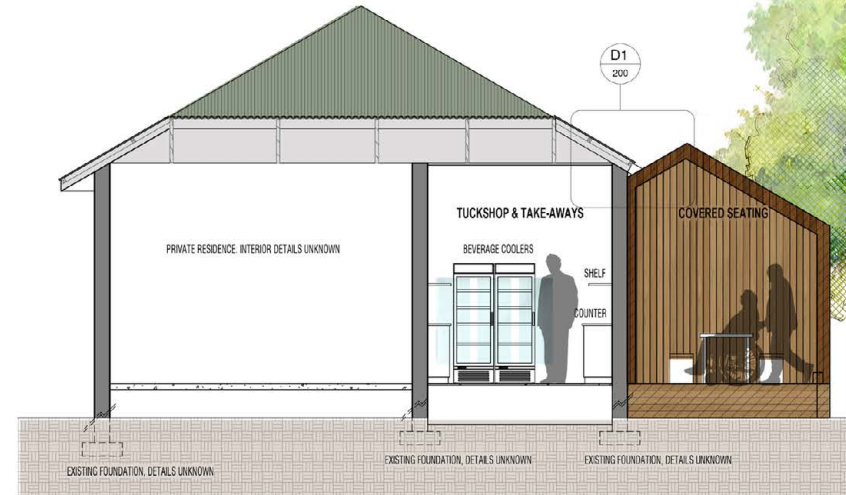
Figure 5.3.66: Tuckshop section, not to scale (Author 2017)

Figure 5.3.67: Roof construction detail, not to scale (Author 2017)

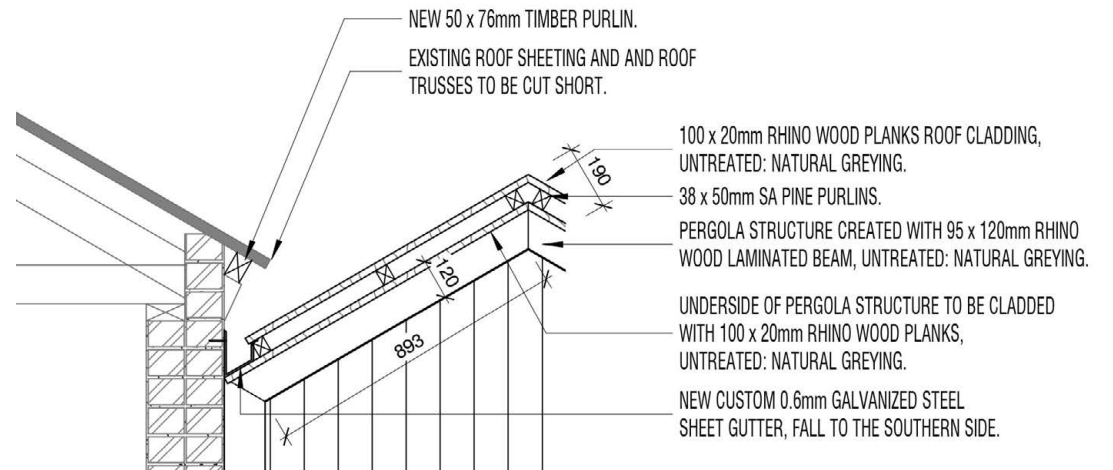
Figure 5.3.68: Tuckshop and take-aways exterior perspective (Author 2017)



TUCKSHOP DETAIL LAYOUT



TUCKSHOP SECTION



ROOF CONSTRUCTION DETAIL



### 5.3.16 FURNITURE SELECTION

#### LANDSCAPE FURNITURE



**Material:** Concrete bench with a timber slat seat  
**Dimensions:** 1500(length) x 495(depth) x 450(height)mm  
**Supplier:** Float Design  
**Reference:** <http://www.floatdesign.co.za/>  
**Position:** Landscape/ Tuckshop deck

#### TUCKSHOP DECK FURNITURE



**Name:** Ikon table  
**Material:** Concrete top with a powdercoated steel base  
**Colour:** Dark Grey  
**Dimensions:** 2700(length) x 800(depth) x 750(height)mm  
**Supplier:** Float Design  
**Reference:** <http://www.floatdesign.co.za/>

#### YOUTH HOSTEL FIRST FLOOR FURNITURE



**Name:** Mimic soft seating  
**Material:** Upholstered seat with a metal frame  
**Colour:** Charcoal and feature yellow  
**Dimensions:** 710(width) x 710(depth) x 420(seat height)mm per "block"  
**Supplier:** Cecil Nurse  
**Reference:** <http://www.cecilnurse.co.za/category/25/heading/>



**Name:** Kensho Poufs  
**Material:** Upholstered poufs  
**Colour:** Two-tone shades  
**Supplier:** Cecil Nurse  
**Reference:** <http://www.cecilnurse.co.za/category/25/heading/406>

#### RESTAURANT FURNITURE



**Name:** PW018 Chair  
**Material:** Polypropylene and timber chair  
**Colour:** White  
**Dimensions:** 430(width) x 450(seat height) x 750(height)mm  
**Supplier:** Chair Crazy  
**Reference:** <http://www.chaircrazy.co.za/p/533e7f9c2c2bf43d849f7938?category=Chairs>



**Name:** GTZ-208S - Square Table  
**Material:** MDF top and beach wood legs  
**Colour:** White  
**Dimensions:** 700/800(width) x 700/800(depth) x 730(height)mm  
**Supplier:** Chair Crazy  
**Reference:** <http://www.chaircrazy.co.za/p/57c410dcf1c8272c5d61daec?category=Tables>



**Name:** Air Barstool H75  
**Material:** Polypropylene reinforced with glass fibre  
**Colour:** Dark Grey  
**Dimensions:** 450(width) x 530(depth) x 750(height)mm  
**Supplier:** Sit SA  
**Reference:** <http://www.sit-sa.co.za/product/air-bar-stool-h75/>  
**Position:** Restaurant and youth hostel first floor

Figure 5.3.69 - 5.3.74: Furniture specifications (reference as indicated)

### 5.3.17 GREEN STAR RATING

The Green Star Interiors tool (V1) is used to rate the environmental sustainability of the project (see Table 5.3.1).

- **Int-Man: Management Category:** The author is a Green Star SA accredited professional. A detailed management plan for owners and tenants will be put in place, with maintenance guidelines specific to heritage fabric. The waste generated through demolition, for example bricks and metal roof sheets have heritage value and can be reused. An understanding of heritage fabric will serve as a public learning resource.
- **Int-IEQ: Indoor Environmental Quality Category:** Provision is made for additional openable window sections and natural cross-ventilation in the interior spaces. Thermal comfort is taken into account through specialized trimming of the trees in the natural landscape. Refer to the explanation of the thermal and acoustic treatment of the youth hostel's first floor in 5.3.9. Natural daylight to the interior spaces is supplemented with additional openings where possible. New openings in existing walls were created to assist with movement and ergonomics.
- **Int-Ene: Energy Category:** The different commercial functions in the precinct will all be sub-metered to regulate energy consumption.
- **Int-Tra: Transport Category:** The site for the tourist precinct was selected due to its advantages in public and alternative transport, with a resulting high rating achieved in the category.
- **Int-Wat: Water Category:** Although it has not been implemented yet in the precinct, grey-water can be used to irrigate the landscape and flush the toilet. Sub-metering is installed to regulate the water consumption of owners and tenants.
- **Int-Mat: Materials Category:** The restaurant's service yard makes provision for the sorting of waste. Most of the existing interior floor materials are used as is, with minimal treatment. An environmentally friendly, low VOC paint is used for the interior walls. New flooring and joinery materials with a recycled content are given preference.
- **Int-Eco: Land Use and Ecology Category:** The reuse of existing structures minimised the need for demolition and use of new land.
- **Int-Emi: Emissions Category:** The lighting of the new functions is designed to blend in with the residential character of the precinct.

While currently still in development phase, the Socio-Economic and Sustainable Precinct tools would also be applicable to the specific project.

In the Socio-Economic category points can be earned for employment creation, community benefit and empowerment (GBCSA 2017).

The Sustainable Precinct Tool assesses the environmental performance of precincts or neighbourhoods and awards points for community resilience (GBCSA 2017).



### Score Sheet Green Star SA - Interiors v1

Credit	Credit Name	Aim of Credit	Points Available	Points Awarded
<b>Management Category</b>				
Int-Man-1	Green Star SA Accredited Professional	To encourage and recognise the engagement of professionals who can assist the project team with the integration of Green Star SA aims and processes throughout all stages of a fitout's design and construction phases.	1	1
Int-Man-2	Commissioning & Tuning	To recognise effective commissioning and tuning processes during a project's design and construction phase that ensure all services and installations can operate to their optimal design potential.	2	2
Int-Man-3	Occupant Users' Guide	To encourage and recognise the provision of information to fitout owners and users that helps them understand a project's systems, environmental attributes, and maintenance requirements.	1	1
Int-Man-4	Environmental Management	To encourage and recognise the adoption of a formal environmental management system in line with established guidelines during construction.	1,5	1
Int-Man-5	Construction Waste Management	To recognise and encourage management practises that minimise the amount of demolition and construction waste going to disposal.	2	2
Int-Man-6	Work space efficiency	To recognise the design of workspaces that provide spatial efficiency and improve productivity and occupant performance.	2	1
Int-Man-7	Green Lease	To recognise and encourage collaboration between the building owner and tenants in order to manage and operate the building along environmentally sustainable principles whilst realising mutual benefit.	2	2
Int-Man-8	Learning Resources	To encourage and recognise sustainability initiatives implemented in the development as learning resources for building users and visitors	1	1
<b>Management credits</b>			<b>12,5</b>	<b>11</b>
<b>Indoor Environmental Quality Category</b>				
Int-IEQ-1	Quality of Internal Air	To encourage and recognise projects that provide high quality air to occupants.	4	3
Int-IEQ-2	Thermal Comfort	To encourage and recognise fitouts that achieve a high level of thermal comfort.	2	2
Int-IEQ-3	Lighting Comfort	To encourage, recognise and reward well-lit spaces that provide appropriate levels of lighting comfort to occupants.	3	2
Int-IEQ-4	Visual Comfort	To recognise the delivery of well daylight spaces that provide high levels of visual comfort and views to fit-out occupants.	3	2
Int-IEQ-5	Acoustic Quality	To encourage and recognise buildings that are designed to provide appropriate acoustic qualities to enable the functionality of the space.	2	2
Int-IEQ-6	Reduced Exposure to Air Pollutants	To recognise projects that safeguard occupant health through the reduction in internal air pollutant levels.	5	4
Int-IEQ-7	Mould Prevention	To encourage and recognise the design of services that eliminates the risk of mould growth and its associated detrimental impact on occupant health.	0,5	0,5
Int-IEQ-8	Ergonomics	To recognise the choice of equipment and design of spaces that promotes wellbeing, efficiency and effectiveness	2	2
Int-IEQ-9	Indoor Plants	To encourage and recognise the installation of indoor plants that improve indoor environment quality and also provides occupants with a connection to nature.	1,5	0,5
<b>Indoor Environmental Quality credits</b>			<b>23</b>	<b>18</b>
<b>Energy Category</b>				
Int-Ene-1	Greenhouse Gas Emissions	To encourage and recognise projects that minimise the greenhouse gas emissions associated with tenant fit outs.	12	6
Int-Ene-2	Electrical Sub-metering	To encourage and recognise the installation of electrical energy sub-metering to facilitate on-going management of electrical energy consumption.	2	2
<b>Energy credits</b>			<b>14</b>	<b>8</b>

<b>Transport Category</b>				
Int-Tra-1	Commuting Mass Transport	To encourage and recognise developments that select a site near public transport and facilitate the use of mass transport.	1	1
Int-Tra-2	Local connectivity	To encourage and recognise projects that are located within walking distance of high quality amenities such as shops and parks, thus reducing private vehicle use and the associated negative environmental impacts.	1	1
Int-Tra-3	Alternative Transport	To encourage and recognise projects that promote and facilitate the use of alternative modes of transport over the use of private cars.	2	2
<b>Transport credits</b>			<b>4</b>	<b>4</b>
<b>Water Category</b>				
Int-Wat-1	Potable Water	To recognise projects that minimise potable water consumption	6	2
Int-Wat-2	Water Sub-metering	To encourage and recognise the installation of sub-metering to facilitate on-going management of water consumption	2	2
<b>Water credits</b>			<b>8</b>	<b>4</b>
<b>Materials Category</b>				
Int-Mat-1	Operational Waste Management	To encourage and recognise developments which include space and an operational waste management plan that facilitates the recovery of resources used within the developments to reduce waste going to disposal.	2	1
Int-Mat-2	Furniture	To recognise the selection of fit-out furniture that has a reduced environmental impact when compared to available alternatives.	8	6
Int-Mat-3	Assemblies	To recognise the selection of fit-out assemblies that have a reduced environmental impact when compared to available alternatives.	8	5
Int-Mat-4	Flooring	To recognise the selection of flooring that has a reduced environmental impact when compared to available alternatives.	6	5
Int-Mat-5	Wall coverings	To recognise the selection of wall coverings that have a reduced environmental impact when compared to available alternatives.	3	3
Int-Mat-6	Local Sourcing	To encourage and recognise the environmental advantages gained, in the form of reduced transportation emissions, by using materials and products that are sourced within close proximity to the site.	2	1
Int-Mat-7	Sundries Materials Sourcing	To recognise the selection of fitout finishes that have a reduced environmental impact when compared to available alternatives through responsible manufacturing, product stewardship and resource efficient design.	1	1
<b>Materials credits</b>			<b>30</b>	<b>22</b>
<b>Land Use and Ecology Category</b>				
Int-Eco-1	Site selection	To recognise and reward a tenant for selecting their space in a building that reduces their environmental impact due to the building's base building design attributes.	4	4
<b>Land use and Ecology credits</b>			<b>4</b>	<b>4</b>
<b>Emissions Category</b>				
Int-Emi-1	Impacts from refrigerants and insulants	To encourage and recognise the avoidance of substances that contribute to the deterioration and long-term alteration of the Earth's atmosphere.	3	2
Int-Emi-2	Light Pollution	To encourage and recognise developments that minimise light pollution into the night sky.	1,5	1
<b>Emissions credits</b>			<b>4,5</b>	<b>3</b>
<b>Innovation Category</b>				
Int-Inn-1	Innovative Strategies & Technologies	To encourage and recognise pioneering initiatives in sustainable design, process or advocacy.		0
Int-Inn-2	Exceeding Green Star SA Benchmarks	To encourage and recognise projects that achieve environmental benefits in excess of the current Green Star SA benchmarks.		0
Int-Inn-3	Environmental Design Initiatives	To encourage and recognise sustainable building initiatives that are currently outside of the scope of this Green Star SA rating tool but which have a substantial or significant environmental benefit.		0
<b>Innovation credits</b>			<b>10</b>	<b>0</b>

<b>TOTAL POINTS AVAILABLE</b>	<b>100</b>	<b>74</b>
-------------------------------	------------	-----------

Table 5.3.6: Green Star SA Interiors v1 Score Sheet (Author 2017)



### 5.3.17 CONCLUSION

Chapter 5 took the project from informants, through concept and design development to technical resolution, and testing. The approach to heritage fabric (as established in Chapter 2) proved to be one of the key factors of the design, with all design and technical decisions informed by it. A successful change in function is achieved, contributing to the resilience and sustainability of the historic built structures and the community.



# CHAPTER 6: CONCLUSION





## 6.1 RECAPITULATION

The dissertation's starting point was the documentation and analysis of heritage fabric embedded in the interior of the identified Nederlandsche Zuid-Afrikaansche Spoorweg-Maatschappij (NZASM) domestic structures in the Pretoria CBD, according to the recommendations made by Schalk Le Roux in 1990. Possible regeneration strategies were investigated as a method of securing these heritage fabrics' continued existence. It was found that the introduction of tourism could be implemented as the catalyst to regenerate the specific site, and to acknowledge and celebrate the cultural significance of the historical residential structures and community. Through design development led by informants from theory, case studies and precedents, the study proposed and presented design changes towards adapting the residential site to a tourist precinct through adaptive reuse.

**Figure 6.1 Chapter cover image:** *Initial hand drawn elevation overlaid with final elevation of Tulleken Street (Author 2017)*

### 6.1.1 CHAPTER SUMMARIES

Chapter 1 presented an overview of the study, its purpose, and research questions.

Chapter 2, which analysed the physical and social context of the study site. Through documentation and analysis of the area and historic houses, a statement of significance was generated, and tourism was identified as a possible catalyst for regeneration.

Chapter 3 investigated theories on heritage alteration, resilience and tourism. A regeneration strategy was developed, outlining the idea that a resilient and sustainable community is key to preserving precious heritage fabric, which in turn can promote heritage and cultural tourism. The strategy substantiated tourism as a regeneration catalyst.

Chapter 4 analysed case studies and precedents specifically relatable to heritage alteration and tourism as programme. Through a review of these case studies and precedents, it was established that an umbrella approach is not appropriate to conserve heritage fabric, but rather that a personalised strategy is required. This personalised strategy should take the particulars of each case into account in collaboration with the occupants residing in the heritage structure.

Chapter 5 developed the design from concept to technical resolution. Design informants were summarised from Chapters 2 to 4, which assisted in formalising the conceptual approach, envisioned atmosphere, urban and cultural vision for the site and the proposed materiality realised through iterations of the existing materials.

## 6.2 CONCLUSIONS

The specifics of the chosen site informed the details of the study. Through detailed analysis of heritage fabric found in the interior it is possible to repurpose the urban context from the "inside out", with decisions for the architectural and urban interventions informed by reinterpretations of the interior. In this way precious fabric hidden in private residential interiors can be made accessible in the public realm, as a celebration of the site's historic past and present cultural diversity.

The alteration of heritage fabric is required for a successful change in function from a residential site to a tourist precinct. The celebration of the memory of demolished heritage fabric, and the connection between old and new fabric are key to the technical resolution of the intervention. The three identified approaches to the addition of new

### 6.3 CONTRIBUTIONS

fabric (please refer back to Section 5.3.5, in Chapter 5) were tested during the various historical alterations, namely: the copy, the complimentary and the contrast. It was found, however, that for a successful contemporary intervention, neither of the three approaches can exist alone, but require supplementary elements from one another.

In many areas of Pretoria, as well as throughout the rest of South Africa, similar houses dating from the start of the 20th century exist; many in a state of degradation. Through analysis and a statement of significance, the appropriate catalyst, such as that proposed in this study, can be offered as a potential regeneration strategy, ensuring the resilience of not only the historical structures but also the community residing in these structures.

The study is significant in that the approach to heritage fabric, and the assessment and articulation of cultural importance found within can be applied to similar heritage pockets in South Africa. The process followed serves as an example for ensuring the present-day relevance of historical domestic interiors, while minimising the deterioration of their historical and cultural value.

The position in the continuum of interior architectural thinking is in the approach to alteration. This is a topic which has gained relevance in recent years through the theories of Brooker and Stone (2004), and Scott (2008), and which includes the relationship and connection between old and new fabric.

The documentation and heritage assessment of the identified houses also make an archival contribution, as they address the recommendations set forth by Le Roux (1990:161), who suggested that researchers analyse and document the specific site in terms of its architectural, cultural and urban features. The analysis led to a strategy for dealing with heritage fabric in domestic houses. This can, subsequently, lead to the preservation and strengthening of the NZASM heritage in South Africa.

### 6.4 RECOMMENDATIONS FOR FURTHER RESEARCH

Specific to the NZASM Tourist Precinct, a management plan can be developed to assist the owners and tenants of the heritage structures with the conservation and maintenance of their houses. Each house will have a custom management plan addressing the needs of the specific precious heritage fabric contained in the structure.

More generally, the regeneration strategy developed (please refer back to Section 3.4, in Chapter 3) can be tested in similar heritage contexts in other parts of South Africa, with the proposed new functionality adjusted according to the specific site details and requirements. Such details will become evident through a context and heritage analysis of the new study areas.

**Figure 6.2:** *NZASM branding concept*  
(Author 2017)



NZASM

## LIST OF REFERENCES

- Albertini, B. and Bagnoli, A. 1988. *Carlo Scarpa: Architecture in Details*. 1st MIT Press Edition. Cambridge: MIT Press.
- Alexander, C. 1979. *The Timeless Way of Building*. New York: Oxford University Press.
- ArchDaily. 2010. *Gehry Residence/Frank Gehry*. [Online]. Available at <<http://www.archdaily.com/67321/gehry-residence-frank-gehry>> [Accessed 19 April 2017].
- ArchDaily. 2014. *Visitor Center Emscher Village/Ooze Architects*. [Online]. Available at <<http://www.archdaily.com/470106/visitor-center-emscher-village-ooze-architects/>> [Accessed 19 April 2017].
- ArchDaily. 2016. *Spotlight: Sverre Fehn*. [Online]. Available at: <<http://www.archdaily.com/793286/spotlight-sverre-fehn>> [Accessed 28 Apr 2017].
- ArchDaily. 2016. *Tourist House in Tardets*. [Online]. Available at: <<http://www.archdaily.com/780301/tourist-house-in-tardets-v2s-architectes/>> [Accessed 19 April 2017].
- Architect Magazine. 2012. *2012 AIA Honor Awards*. [Online]. Available at: <[http://www.architectmagazine.com/design/frank-gehrys-house\\_o](http://www.architectmagazine.com/design/frank-gehrys-house_o)> [Accessed 12 June 2017].
- Architecture Norway. 2009. *Hedmark Museum, Hamar*. 1967-2005. [Online]. Available at: <<http://architecturenorway.no/stories/photo-stories/binet-hamar-09/>> [Accessed 28 April 2017].
- Bakker, K. A., Clarke, N. J. and Fisher, R. C. 2014. *Eclectic ZA Wilhelmiens: A Shared Dutch Built Heritage in South Africa*. Pretoria: Visual Books.
- Borden, I. and Ray, K. R. 2006. *The Dissertation: An Architecture Student's Handbook*. Second Edition. Oxford: Elsevier.
- Brand South Africa. 2010. *Stopping in Vilakazi Street, Soweto*. [Online]. Available at: <<https://www.brandsouthafrica.com/tourism-south-africa/travel/cultural/vilakazi>> [Accessed 19 April 2017].
- Brooker, G. and Stone, S. 2004. *Re-readings*. London: Riba Enterprises.
- Brümmer, L. 2016. 'RFP730, Quarter 4'. Unpublished Honours (Blnt Hons). Pretoria: University of Pretoria.
- Butina-Watson, G. and Bentley, I. 2007. *Identity by Design*. London: Routledge.
- Clarke, N. J. and Fisher, R. C. 2016. *NZASM Footsteps Along the Tracks: The Identified Extant Built Residue of the Nederlandsche Zuid-Afrikaansche Spoorweg-Maatschappij (1887-1902)*. Pretoria: Visual Books.
- CMU Architecture Scandinavia. 2010. *Hedmark Museum*. [Online]. Available at: <<https://scandinavia2010.wordpress.com/2010/07/14/hedmark-museum/>> [Accessed 28 April 2017].
- David Chipperfield Architects. 2017. n.d. *Neues Museum*. [Online]. Available at: <[https://davidchipperfield.com/project/neues\\_museum](https://davidchipperfield.com/project/neues_museum)> [Accessed 16 June 2017].
- de Jong, R. C. 1985. 'Herinneringe aan die NZASM in en om Pretoria'. *Pretoriana* 91: 8–20.
- de Jong, R. C. 1990. 'Roofs for Railwaymen: A Treatise on Housing Accommodation for Employees of the Netherlands South African Railway Company (NZASM), 1887-1899'. *South African Journal of Cultural History* 4(2): 53–62. [Online]. Available at: <http://journals.co.za/docserver/fulltext/culture/4/2/640.pdf?expires=1508160527&id=id&accname=guest&checksum=F075E382533ADF74073C65BD286A1661>
- de Jong, R. C., van der Waal, G. M. and Heydenrych, D. H. 1988. *NZASM 100: 1887-1899, the Buildings, Steam Engines and Structures of the Netherlands South African Railway Company*. Pretoria: C. Van Rensburg Publications on behalf of the Human Sciences Research Council.
- de Klerk, M. 2017. Professional Consultation. [Conversation]. With: Marianne de Klerk Architects and Urban Designers, 223 Bronkhorst Street, Pretoria. 17 May 2017. 14:00.
- Department of Public Works. 2015. *Tshwane Inner City Regeneration*. [Online]. Available at: <https://www.tshwanetourism.com/newsletter/images/58/presentation.pdf> [Accessed 25 February 2017].
- du Plessis, C. 2013. 'Resilient and Regenerative – The Yin and Yang of a New Development Paradigm'. *Earthworks*, 13: 35–38.
- Ennen, E. and van Maanen, E. 2014. Communicating Heritage as an Instrument in Place Marketing. In J. Kaminski, A. M. Benson and Arnold, D. (eds.), *Contemporary Issues in Cultural Heritage Tourism*, pp.45–55. Oxon: Routledge.
- European Commission. 2014. *Flash Eurobarometer Report: Preferences of Europeans Towards Tourism*. [Online]. Available at: <[http://ec.europa.eu/public\\_opinion/flash/fl\\_392\\_en.pdf](http://ec.europa.eu/public_opinion/flash/fl_392_en.pdf)> [Accessed 7 October 2017].



- Garrod, B. and Fyall, A. 2000. 'Managing Heritage Tourism'. *Annals of Tourism Research* 27(3): 682–708. DOI: 10.1016/S0160-7383(99)00094-8
- Groat, L. N. and Wang, D. 2013. *Architectural Research Methods*. Second Edition. New Jersey: John Wiley & Sons.
- Hollis, E. 2009. *The Secret Lives of Buildings*. London: Portobello Books.
- ICOMOS. 1965. *International Charter for the Conservation and Restoration of Monuments and Sites (The Venice Charter 1964)*. Australia: ICOMOS.
- ICOMOS. 2013. *The Burra Charter: The Australia ICOMOS Charter for Places of Cultural Significance*. Australia: ICOMOS.
- Joroff, M. and Morse, S. 1984. A Proposed Framework for the Emerging Field of Architectural Research. In J. Snyder (ed.) *Architectural Research*, pp. 15–28. New York: Van Nostrand Reinhold.
- le Roux, S. 1990. *Plekke en Geboue van Pretoria*. Volume 1. Pretoria: Pretoria Argitektuurvereniging.
- Lew, A. A., Ng, P. T., Ni, C. and Wu, T. 2016. 'Community Sustainability and Resilience: Similarities, Differences and Indicators'. *Tourism Geographies* 18(1): 18–27. DOI: 10.1080/14616688.2015.1122664
- Lew, A. A. 2014. 'Research Frontiers: Scale, Change and Resilience in Community Tourism Planning'. *Tourism Geographies* 16(1): 14–22. DOI: 10.1080/14616688.2013.864325
- Lynch, K. 1960. *The Image of the City*. Cambridge: Harvard University Press.
- Mears, S. 2017. Personal Interview. [Conversation]. Colbyn, Pretoria. 10 March 2017. 13:00.
- Morris, W. 1878. *The Manifesto of the Society for the Protection of Ancient Buildings*. [Online]. Available at: <https://www.spab.org.uk/what-is-spab-/the-manifesto/> Accessed 15 October 2017.
- Peres, E. M. 2016. 'The Translation of Ecological Resilience Theory into Urban Systems'. Unpublished Doctoral Dissertation. Pretoria: University of Pretoria.
- Peres, E., Barker, A. and du Plessis, C. 2015. 'Architecture for Life: Exploring Regenerative and Resilience Thinking'. *Architecture South Africa* [Online] 71: 40–45. Available at: [https://repository.up.ac.za/dspace/bitstream/handle/2263/45206/Peres\\_Architecture\\_2015.pdf?sequence=1](https://repository.up.ac.za/dspace/bitstream/handle/2263/45206/Peres_Architecture_2015.pdf?sequence=1) [Accessed 10 April 2017].
- Plevoets, B. and van Cleempoel, K. 2011. *Adaptive Reuse as a Strategy towards Conservation of Cultural Heritage: A Literature Review*. Belgium: PHL University College & Hasselt University.
- Republic of South Africa. 1999. *No 25 of 1999: National Heritage Act*. Pretoria: Government of South Africa.
- Scott, F. 2008. *On Altering Architecture*. London: Routledge.
- South Africa. 2005. The Metropolitan Planning Section, City Planning Division & Department of Urban and Regional Planning. *Tshwane Compaction and Densification Strategy*. Pretoria: University of Pretoria.
- Spiekermann, M. 2010. *The Sustainability of Urban Heritage Preservation: The Case of Aleppo*. Inter-American Development Bank Discussion Paper No. IDB-DP-125. Available at: <http://idbdocs.iadb.org/wsdocs/getdocument.aspx?docnum=35335580> [Accessed 13 October 2017].
- Suárez, M., Gómez-Baggethun, E., Benayas, J. and Tilbury, D. 2016. 'Toward an Urban Resilience Index: A Case Study in 50 Spanish Cities'. *Sustainability* 8(774): 1–19. DOI: 10.3390/su8080774
- Tutt, P. and Adler, D. 1990. *Metric Handbook Planning and Design Data*. Oxford: Architectural Press.
- UNESCO. 1999. *Hoi An Ancient Town*. [Online]. Available at: <http://whc.unesco.org/en/list/948/> [Accessed 25 April 2017].
- University of Pretoria. 2012. *Pretoria Station, Paul Kruger Street, Pretoria City Centre, Tshwane*. [Online]. Available at: [http://able.wiki.up.ac.za/index.php/Pretoria\\_Station,\\_Paul\\_Kruger\\_Street,\\_Pretoria\\_City\\_Centre,\\_Tshwane](http://able.wiki.up.ac.za/index.php/Pretoria_Station,_Paul_Kruger_Street,_Pretoria_City_Centre,_Tshwane) [Accessed 22 March 2017].
- University of Pretoria. 2013. *NZASM Guest House, 62 Rissik Street, Sunnyside, Tshwane*. [Online]. Available at: [http://able.wiki.up.ac.za/index.php/NZASM\\_Guest\\_House,\\_62\\_Rissik\\_Street,\\_Sunnyside,\\_Tshwane](http://able.wiki.up.ac.za/index.php/NZASM_Guest_House,_62_Rissik_Street,_Sunnyside,_Tshwane) [Accessed 22 March 2017].
- Ursache, M. 2015. 'Tourism – A Significant Driver Shaping a Destinations Heritage'. *Procedia – Social and Behavioral Sciences* 188: 130–137. DOI: 10.1016/j.sbspro.2015.03.348

## APPENDIX A\_ INFORMAL COMMUNITY DISCUSSION STRUCTURE

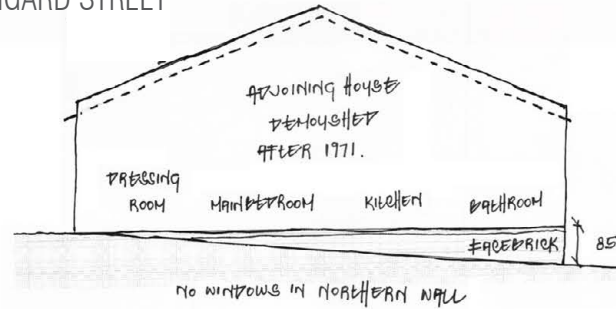
### Questions relating to the house:

1. How long have you been living in your house?
2. Do you know when your house was built?
3. Do you own the house?
4. How many permanent occupants live in your house?
5. Have you made any changes to your house?
  - Structure: Interior/ exterior
  - Finishes: Interior/ exterior
6. Do you know anything about the history of the area and your house?
7. Who lived in the house before you?
8. Are the electricity and plumbing fully functional?
9. Is the temperature in the house comfortable, for example not too cold in the winter?
10. Is there any damage to the structure that you are aware, for example water leaks?
11. If you could change anything about the structure, what would it be?
12. What do you like best about living in your house?

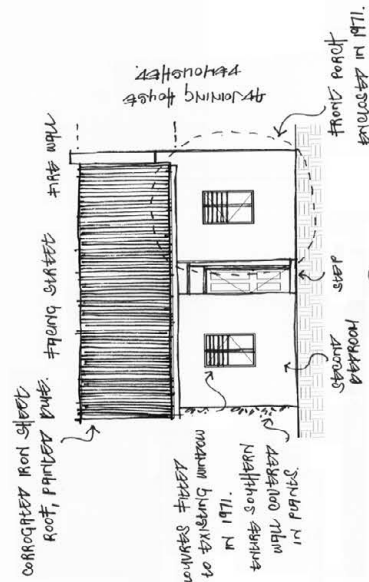
### Questions relating to the area:

1. Please describe your experience of living in the area, for example peaceful, noisy etc.
2. Are the following functions close by:
  - Grocery shops
  - Clinics
  - Schools
3. Do you know the residents of the other houses?
4. Are you aware of any plans for development of the area?
5. What is your experience of Berea Park?
6. Do you make use of the trains nearby? Or other public transport?
7. Is there a good sense of community amongst the residents of the area?
8. Are there many visitors to the area?
9. Is it safe to walk around the streets in the day, and during the night?
10. What type of activities take place:
  - During the day (Mon – Fri)
  - At night
  - On a Saturday
  - On a Sunday
11. Have you ever visited the jazz club, Malombo on the corner of Rider Haggard & Clara?
12. What do you like best about living in the area?

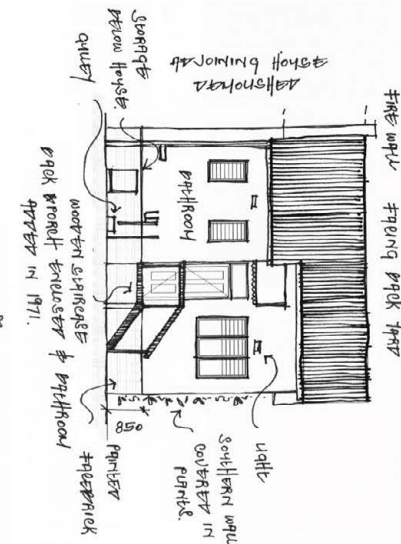
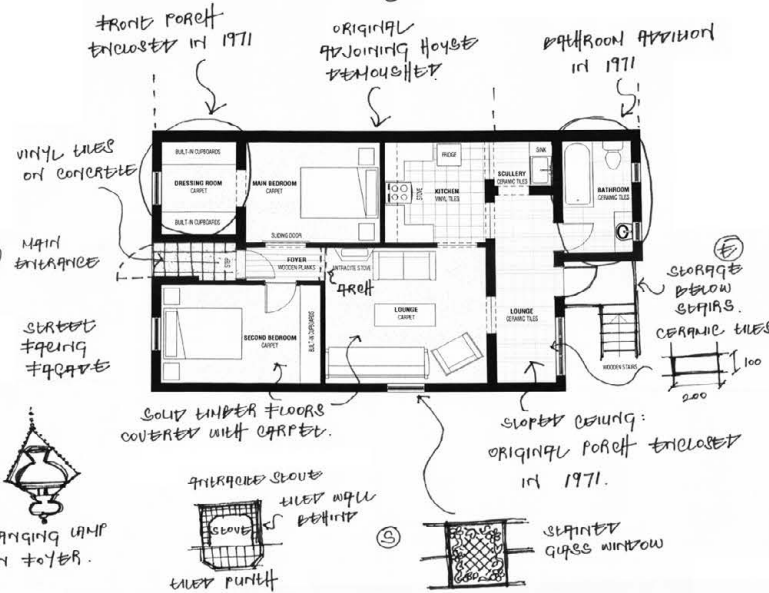
APPENDIX B DOCUMENTATION AND ANALYSIS: 10 RIDER HAGGARD STREET



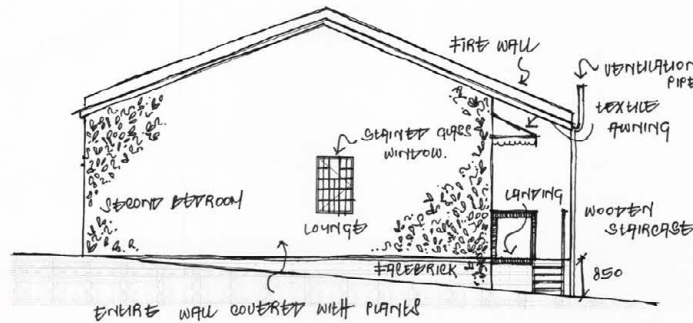
Northern Elevation



Western Elevation



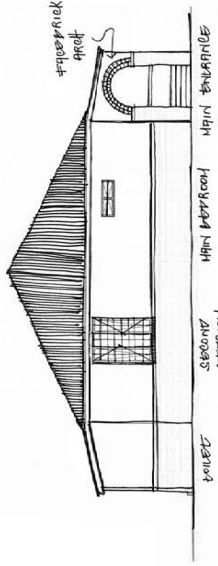
Eastern Elevation



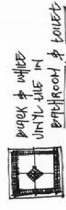
Southern Elevation



# DOCUMENTATION AND ANALYSIS: 25 RIDER HAGGARD STREET



Northern Elevation



WOOD & WHITE  
UNTIL LATE IN  
BRICKWORK, & SOLIDS

KEY & GOLD  
UNTIL LATE IN  
BRICK

2 1/2" RAIL PROFILE, 4" x 1" 100MM METAL  
(WOODEN RAIL, PAINTED GREEN)  
  
SHIRING PROFILE  
(WOODEN SHIRING, PAINTED GREEN)  
  
ROBBER RAIL PROFILE, 4" x 2 1/2" 100MM METAL  
(WOODEN RAIL, PAINTED IN THE FEATURE  
COLOR OF THE ROOF)

VENTILATION BRICK



UNIL MISLAKELY 4" x 4" 100MM  
SPACE WHERE THE WOODEN RAIL  
WOULD BE.

WOODEN  
PAPER ART

MAJORITY FINISHES  
CHIPPED IN WHITE &  
PAINTED IN CREAM  
COLOR.

PAINTED CEILING  
IN DINING ROOM.

WOODEN  
WOODEN

WOODEN  
WOODEN

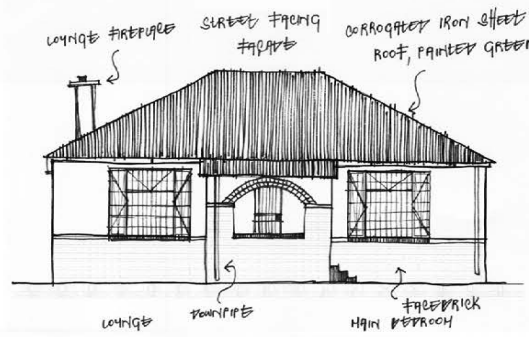
WOODEN  
WOODEN

WOODEN  
WOODEN

WOODEN  
WOODEN

WOODEN  
WOODEN

WOODEN  
WOODEN



Eastern Elevation

LOUVER  
DOWNPIPE  
MAIN ENTRANCE  
FACEBRICK ROOF

LOUVER  
FACEBRICK ROOF, PAINTED GREEN.  
CORROSIVE IRON SHEET

LOUVER  
FACEBRICK ROOF

WOODEN  
WOODEN

WOODEN  
WOODEN

WOODEN  
WOODEN

WOODEN  
WOODEN

WOODEN  
WOODEN

WOODEN  
WOODEN

WOODEN  
WOODEN

WOODEN  
WOODEN

WOODEN  
WOODEN

WOODEN  
WOODEN

WOODEN  
WOODEN

WOODEN  
WOODEN

WOODEN  
WOODEN

WOODEN  
WOODEN

WOODEN  
WOODEN

WOODEN  
WOODEN

WOODEN  
WOODEN

WOODEN  
WOODEN

WOODEN  
WOODEN

WOODEN  
WOODEN

WOODEN  
WOODEN

WOODEN  
WOODEN

WOODEN  
WOODEN

WOODEN  
WOODEN

WOODEN  
WOODEN

WOODEN  
WOODEN

WOODEN  
WOODEN

WOODEN  
WOODEN

WOODEN  
WOODEN

WOODEN  
WOODEN

WOODEN  
WOODEN

WOODEN  
WOODEN

WOODEN  
WOODEN

WOODEN  
WOODEN

WOODEN  
WOODEN

WOODEN  
WOODEN

WOODEN  
WOODEN

WOODEN  
WOODEN

WOODEN  
WOODEN

WOODEN  
WOODEN

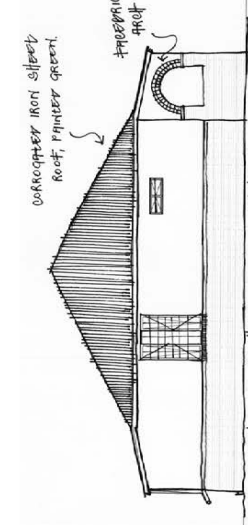
WOODEN  
WOODEN

WOODEN  
WOODEN

WOODEN  
WOODEN

WOODEN  
WOODEN

WOODEN  
WOODEN



Southern Elevation

WOODEN  
WOODEN

WOODEN  
WOODEN

WOODEN  
WOODEN

WOODEN  
WOODEN

WOODEN  
WOODEN

WOODEN  
WOODEN

WOODEN  
WOODEN

WOODEN  
WOODEN

WOODEN  
WOODEN

WOODEN  
WOODEN

WOODEN  
WOODEN

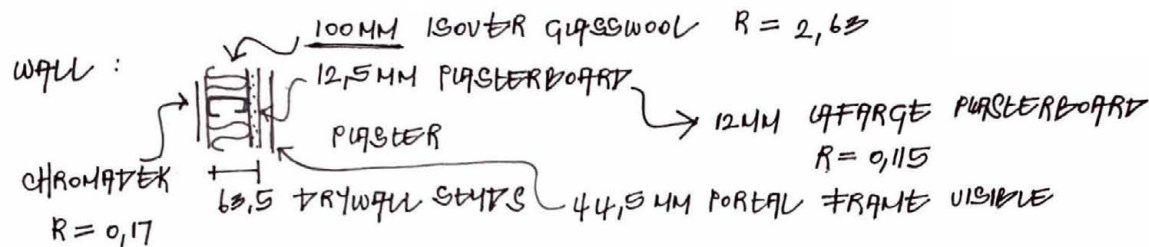


## APPENDIX C\_ THERMAL CALCULATIONS FOR THE YOUTH HOSTEL

$R = \text{THERMAL RESISTANCE} : m^2 K/W$

$$R_{\text{TOTAL}} = R_{\text{si}} + R_{\text{MATERIALS}} + R_{\text{equity}} + R_{\text{so}}$$

$\downarrow$  INSIDE SURFACE                       $\downarrow$  OUTSIDE SURFACE



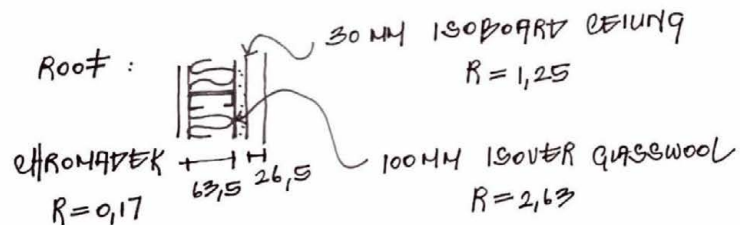
$$R_{\text{total}} = 0,17 + 2,63 + 0,115$$

$$= 2,915 m^2 K/W$$

$$U\text{-VALUE} = \frac{1}{R}$$

$$= \frac{1}{2,915}$$

$$= \underline{0,34} \text{ W/m}^2 K$$



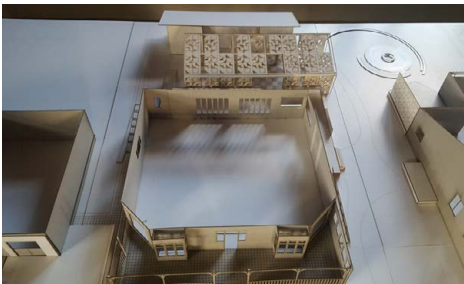
$$R_{\text{total}} = 0,17 + 2,63 + 1,25$$

$$= 4,05 m^2 K/W$$

$$U\text{-VALUE} = \frac{1}{4,05}$$

$$= \underline{0,25} \text{ W/m}^2 K$$

APPENDIX D\_ FINAL MODEL



APPENDIX E\_ FINAL EXAMINATION



# APPENDIX F\_FINAL POSTERS

## The NZASM Tourist Precinct

Tourism interventions as catalyst to re-establish the cultural significance of historic railway housing in Pretoria CBD



LUUKKA BOMMER 04022020, MARCH 2017

Research Field: Heritage and Cultural Landscapes (HCL)  
Programme: Thesis Project  
Site location: Tulliken Street and Tulliken Street, east of the Pretoria Train Station, in the South-East Suburb of Pretoria 000, South Africa

### CHAPTER 1: STUDY PROPOSAL

**PROBLEM STATEMENT**  
A catalyst to re-establish and enhance the cultural significance of the historic residential structures located to the east of the Pretoria Train Station, in the NZASM heritage area. The study aims to re-establish a viable residential fabric, and the required support infrastructure, within a public-private partnership model. The study also aims to re-establish a viable residential fabric, and the required support infrastructure, within a public-private partnership model. The study also aims to re-establish a viable residential fabric, and the required support infrastructure, within a public-private partnership model.

**Main Research Question**  
How can the introduction of structures act as a catalyst to re-establish and enhance the cultural significance of the NZASM housing and the area?  
**Sub-research questions**  
How can the introduction of structures act as a catalyst to re-establish and enhance the cultural significance of the NZASM housing and the area?  
How can the introduction of structures act as a catalyst to re-establish and enhance the cultural significance of the NZASM housing and the area?

**KEY OBJECTIVES**  
The aim of this study is to establish the cultural significance of the NZASM housing and the area by means of the introduction of a residential fabric. The study also aims to re-establish a viable residential fabric, and the required support infrastructure, within a public-private partnership model. The study also aims to re-establish a viable residential fabric, and the required support infrastructure, within a public-private partnership model.

**SIGNIFICANCE OF STUDY**  
The study is significant in that it re-establishes the heritage fabric and the environment and atmosphere of cultural significance can be applied to other heritage areas in South Africa. The study also aims to re-establish a viable residential fabric, and the required support infrastructure, within a public-private partnership model. The study also aims to re-establish a viable residential fabric, and the required support infrastructure, within a public-private partnership model.

**CONTRIBUTION TO HERITAGE ARCHITECTURE**  
The study contributes to the field of heritage architecture by re-establishing the heritage fabric and the environment and atmosphere of cultural significance can be applied to other heritage areas in South Africa. The study also aims to re-establish a viable residential fabric, and the required support infrastructure, within a public-private partnership model. The study also aims to re-establish a viable residential fabric, and the required support infrastructure, within a public-private partnership model.

**RESEARCH METHODOLOGY**  
The study uses a combination of qualitative and quantitative research methods. The study also aims to re-establish a viable residential fabric, and the required support infrastructure, within a public-private partnership model. The study also aims to re-establish a viable residential fabric, and the required support infrastructure, within a public-private partnership model.

**DEFINITIONS AND LIMITATIONS**  
The study is limited to the area of the NZASM housing and the area. The study also aims to re-establish a viable residential fabric, and the required support infrastructure, within a public-private partnership model. The study also aims to re-establish a viable residential fabric, and the required support infrastructure, within a public-private partnership model.

**ASSUMPTIONS**  
The study assumes that the introduction of structures will re-establish the heritage fabric and the environment and atmosphere of cultural significance can be applied to other heritage areas in South Africa. The study also aims to re-establish a viable residential fabric, and the required support infrastructure, within a public-private partnership model. The study also aims to re-establish a viable residential fabric, and the required support infrastructure, within a public-private partnership model.

## CHAPTER 2: CONTEXT STUDY

Analysis of existing historical context



**HISTORICAL DEVELOPMENT OF THE AREA**  
The area of the study is situated in the southeast suburb of Pretoria, east of the Pretoria Train Station. The area was developed in the early 20th century as a residential area for the railway workers. The area was developed in the early 20th century as a residential area for the railway workers. The area was developed in the early 20th century as a residential area for the railway workers.

**MAP OF TYPOLOGIES**  
The map shows the different types of housing typologies in the area. The map shows the different types of housing typologies in the area. The map shows the different types of housing typologies in the area.

**SIMILAR NZASM HOUSING TYPOLOGY IN PRETORIA**

The images show different housing typologies in Pretoria, including single houses, duplexes, and townhouses. The images show different housing typologies in Pretoria, including single houses, duplexes, and townhouses. The images show different housing typologies in Pretoria, including single houses, duplexes, and townhouses.



## CHAPTER 2: CONTEXT STUDY

Timeline

**HISTORICAL DEVELOPMENT OF SITE**  
The study area is situated in the southeast suburb of Pretoria, east of the Pretoria Train Station. The area was developed in the early 20th century as a residential area for the railway workers. The area was developed in the early 20th century as a residential area for the railway workers. The area was developed in the early 20th century as a residential area for the railway workers.

**Timeline**  
1879: The area is developed as a residential area for the railway workers.  
1890: The area is developed as a residential area for the railway workers.  
1902: The area is developed as a residential area for the railway workers.  
1919: The area is developed as a residential area for the railway workers.  
1949: The area is developed as a residential area for the railway workers.  
1979: The area is developed as a residential area for the railway workers.  
1990: The area is developed as a residential area for the railway workers.

## CHAPTER 2: CONTEXT STUDY

Analysis of existing: Functions, boundaries and movement

**15 - 23 TULLEKEN STREET ELEVATION (EAST TO WEST)**

**SITE PLAN: EXISTING FUNCTIONS**

**MAPPING OF BOUNDARIES**

**MAPPING OF EXISTING USE AND MOVEMENT**



### CHAPTER 2: CONTEXT STUDY

#### Analysis of existing: Sidewalk and solar

**PLAN OF TULLEKEN STREET SIDEWALK**

**SECTION THROUGH TULLEKEN STREET SIDEWALK**

**SOLAR STUDY**

	08:00	10:00	12:00	14:00	16:00
20 March					
21 June					
22 September					
21 December					

*Severe shadows cast on the houses to the north*

The solar study was conducted using the 'Sun' application on a mobile phone. The results are presented in a series of diagrams showing the sun's position and the shadows cast by the buildings and trees. The diagrams are arranged in a grid, with the date and time for each study indicated. The diagrams show that the shadows cast by the buildings and trees are most severe during the winter months (June and September) and are most pronounced during the middle of the day (12:00). The diagrams also show that the shadows cast by the trees are most severe during the summer months (March and December) and are most pronounced during the middle of the day (12:00).

### CHAPTER 2: CONTEXT STUDY

#### Documentation & Analysis: 15 & 17 Tulleken Street

**SITE KEYPLAN**

**NORTHERN ELEVATION**

**SOUTHERN ELEVATION**

**WESTERN ELEVATION**

**EASTERN ELEVATION**

**FLOOR PLAN**

**COMPARISON WITH NZASM HOUSING TYPE B**

**When comparing 15 and 17 Tulleken Street to NZASM Housing Type B:**

- Similarities:
  - Two-storey structure
  - Front porch
  - Side porch
  - Roof structure
  - Window placements
  - Door placements
- Differences:
  - Roof structure
  - Window placements
  - Door placements
  - Material choices
  - Color choices
  - Landscaping
  - Site context

**When comparing 15 and 17 Tulleken Street to NZASM Housing Type C:**

- Similarities:
  - Two-storey structure
  - Front porch
  - Side porch
  - Roof structure
  - Window placements
  - Door placements
- Differences:
  - Roof structure
  - Window placements
  - Door placements
  - Material choices
  - Color choices
  - Landscaping
  - Site context

Some house features appear to differ from an observation around 1980. To match the style of the building, the roof structure, window, and door placements were adjusted.

### CHAPTER 2: CONTEXT STUDY

#### Documentation & Analysis: 19 Tulleken Street

**SITE KEYPLAN**

**NORTHERN ELEVATION**

**SOUTHERN ELEVATION**

**FLOOR PLAN**

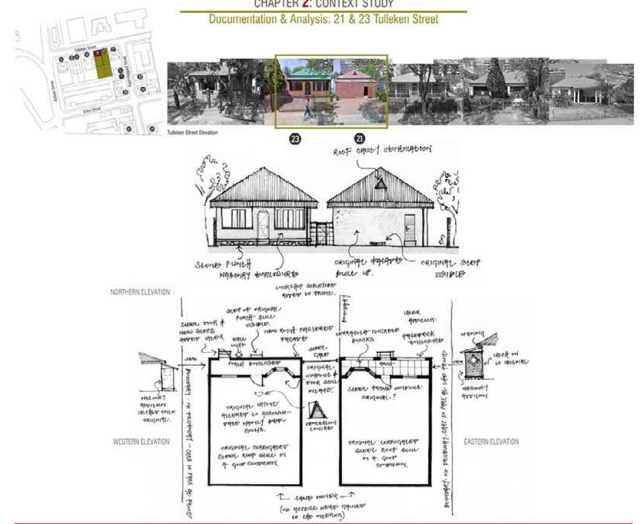
**COMPARISON WITH NZASM HOUSING TYPE C**

**When comparing 19 Tulleken Street to NZASM Housing Type C:**

- Similarities:
  - Two-storey structure
  - Front porch
  - Side porch
  - Roof structure
  - Window placements
  - Door placements
- Differences:
  - Roof structure
  - Window placements
  - Door placements
  - Material choices
  - Color choices
  - Landscaping
  - Site context

Some house features appear to differ from an observation around 1980. To match the style of the building, the roof structure, window, and door placements were adjusted.

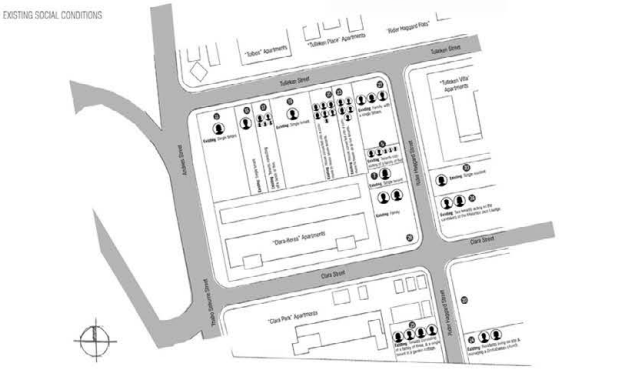
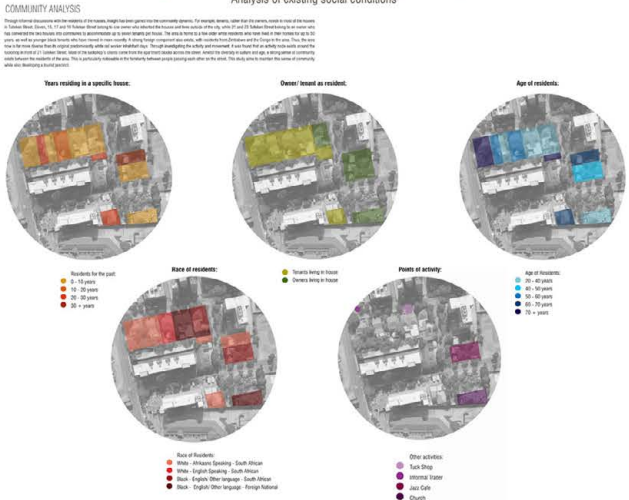
CHAPTER 2: CONTEXT STUDY  
Documentation & Analysis: 21 & 23 Tulleken Street



OVERALL HERITAGE FINDINGS

13 & 17 Tulleken Street	19 Tulleken Street	21 & 23 Tulleken Street
<ul style="list-style-type: none"> <li>1. Original brick facade has been replaced with light-colored plaster.</li> <li>2. Original floor has been replaced with a concrete slab.</li> <li>3. The original brickwork has been removed and replaced with concrete.</li> <li>4. The brick has been completely replaced with a new one.</li> <li>5. The brick has been replaced with a new one.</li> <li>6. The brick has been replaced with a new one.</li> <li>7. The brick has been replaced with a new one.</li> <li>8. The brick has been replaced with a new one.</li> <li>9. The brick has been replaced with a new one.</li> <li>10. The brick has been replaced with a new one.</li> </ul>	<ul style="list-style-type: none"> <li>1. Original brick facade has been replaced with light-colored plaster.</li> <li>2. Original floor has been replaced with a concrete slab.</li> <li>3. The original brickwork has been removed and replaced with concrete.</li> <li>4. The brick has been completely replaced with a new one.</li> <li>5. The brick has been replaced with a new one.</li> <li>6. The brick has been replaced with a new one.</li> <li>7. The brick has been replaced with a new one.</li> <li>8. The brick has been replaced with a new one.</li> <li>9. The brick has been replaced with a new one.</li> <li>10. The brick has been replaced with a new one.</li> </ul>	<ul style="list-style-type: none"> <li>1. High quality of architectural finishes.</li> <li>2. Original architectural style.</li> <li>3. Original architectural style.</li> <li>4. Original architectural style.</li> <li>5. Original architectural style.</li> <li>6. Original architectural style.</li> <li>7. Original architectural style.</li> <li>8. Original architectural style.</li> <li>9. Original architectural style.</li> <li>10. Original architectural style.</li> </ul>

CHAPTER 2: CONTEXT STUDY  
Analysis of existing social conditions



CHAPTER 2: CONTEXT STUDY  
Analysis of existing; Statement of Significance

The proposed site can be analysed according to the Charter's standards:

**Heritage**

The structures are older than 60 years and thus protected by the National Heritage Act (No. 25 of 1996). They hold historic value as a representation of Pretoria's early built form and the residential development of a century ago. Heritage buildings are found in the built fabric, such as the present retail trading, domestic residential blocks and small built-in structures. These buildings are significant and should be preserved because they are part of the built fabric which they state, evidence to the structure and process in a building. The additional topic should be preserved and the original material.

**Scientific**

The structures are scientifically informative with regard to early 20th century building methods and materials. Each individual includes well-wooded plastered floors, wooden ceilings, walls, tiles and other details. Double brick masonry walls, high-pressure metal ceiling, natural stone floor, original or later provision made for tiles, and no structural wiring in the walls.

**Scope & Extent**

Social and spatial significance lie in the community on site, who have developed a sense of place and a sense of change in the urban context. Residents who have lived on site for up to 50 years are witness to the changing city and play a meaningful role in the cultural significance of the site, particularly in terms of the experience and knowledge they can contribute. The social value on site also lies in the potential for buildings that connect the residents, who are diverse in age, culture and place of origin.

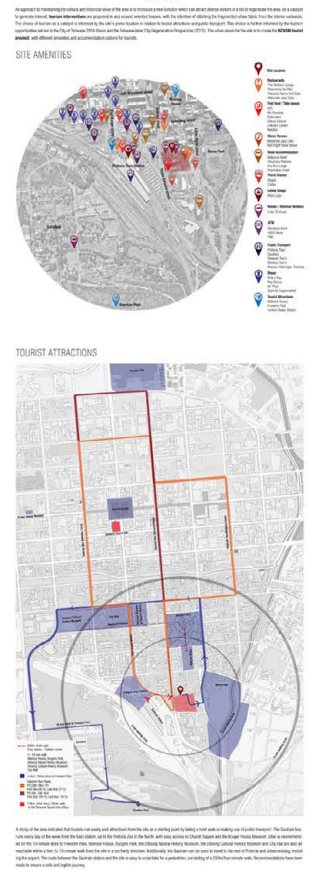
The heritage approach to the structures on site will not be uniform throughout, but determined by each house's condition and cultural significance. A combination of the following approaches is considered:

- The process of conservation, which implies using for a place to ensure that its cultural significance is maintained.
- The process of maintenance, ensuring the continuous protection care of a place and its setting is maintained.
- The process of adaptation, such as changing the place to suit the existing use or a present use, is incorporated.
- The process of preservation, which means maintaining a place in its existing state and retaining its appearance, is applied to it.
- The process of restoration, through returning a place to a known earlier state by removing alterations or by reconstituting missing elements without the introduction of new material, is employed (ICOMOS 2013).

**Design guidelines that can be derived from the Statement of Significance are:**

- The heritage and historic features of the site should be preserved and maintained.
- Buildings that do not contribute to the heritage value of the site should be removed or replaced where necessary to restore and conserve heritage features; and
- The structures are informative regarding Pretoria's historical context and can play a role in the public realm of the site.

CHAPTER 2: PROGRAMME  
Tourism



CHAPTER 2: PROGRAMME

Tourism

CITY OF TSHWANE 2055 VISION (2013)

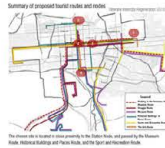
**Summary of key elements that influence, determine and constrain** (Source: Vision 2055 2013:12)

**Role of government** - Government has a role to play in the City of Tshwane as well as to strengthen. The City of Tshwane can improve the programme speed of urban activities to ensure that the city is a vibrant, economically growing, socially just, and environmentally sustainable city.

**Urban form** - The City of Tshwane will be a vibrant, economically growing, socially just, and environmentally sustainable city. The City of Tshwane will be a vibrant, economically growing, socially just, and environmentally sustainable city.

**Urban form** - The City of Tshwane will be a vibrant, economically growing, socially just, and environmentally sustainable city. The City of Tshwane will be a vibrant, economically growing, socially just, and environmentally sustainable city.

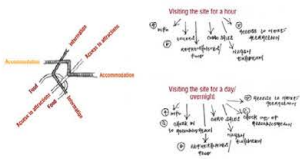
TSHWANE INNERCITY REGENERATION (2015)



THE TSHWANE TOURIST INFORMATION CRITIQUE



FUNCTIONAL REQUIREMENTS OF A TOURIST PRECINCT



ROUTE FROM GAUTRAIN STATION TO SITE



PROGRAMMATIC LAYOUT OF THE NZAMA TOURIST PRECINCT



Zone	Area	Area (m²)	Use	Notes
Zone 1	...	...	...	...
Zone 2	...	...	...	...
Zone 3	...	...	...	...
Zone 4	...	...	...	...
Zone 5	...	...	...	...
Zone 6	...	...	...	...
Zone 7	...	...	...	...
Zone 8	...	...	...	...
Zone 9	...	...	...	...
Zone 10	...	...	...	...
Zone 11	...	...	...	...
Zone 12	...	...	...	...
Zone 13	...	...	...	...
Zone 14	...	...	...	...
Zone 15	...	...	...	...
Zone 16	...	...	...	...
Zone 17	...	...	...	...
Zone 18	...	...	...	...
Zone 19	...	...	...	...
Zone 20	...	...	...	...
Zone 21	...	...	...	...
Zone 22	...	...	...	...
Zone 23	...	...	...	...
Zone 24	...	...	...	...
Zone 25	...	...	...	...
Zone 26	...	...	...	...
Zone 27	...	...	...	...
Zone 28	...	...	...	...
Zone 29	...	...	...	...
Zone 30	...	...	...	...
Zone 31	...	...	...	...
Zone 32	...	...	...	...
Zone 33	...	...	...	...
Zone 34	...	...	...	...
Zone 35	...	...	...	...
Zone 36	...	...	...	...
Zone 37	...	...	...	...
Zone 38	...	...	...	...
Zone 39	...	...	...	...
Zone 40	...	...	...	...
Zone 41	...	...	...	...
Zone 42	...	...	...	...
Zone 43	...	...	...	...
Zone 44	...	...	...	...
Zone 45	...	...	...	...
Zone 46	...	...	...	...
Zone 47	...	...	...	...
Zone 48	...	...	...	...
Zone 49	...	...	...	...
Zone 50	...	...	...	...

CHAPTER 2: PROGRAMME

Model Users

PROFILE OF THE MODEL COMMUNITY MEMBER

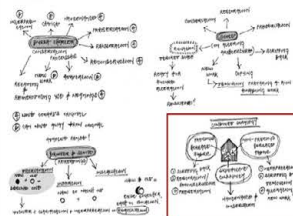


PROFILE OF THE MODEL TOURIST



CHAPTER 3: THEORY

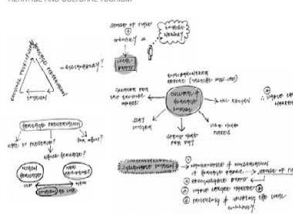
HERITAGE



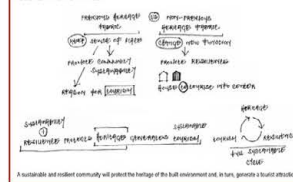
URBAN RESILIENCE



HERITAGE AND CULTURAL TOURISM

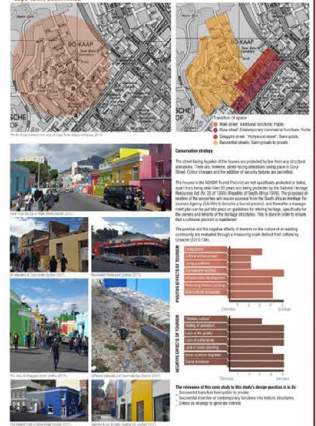


REGENERATION STRATEGY

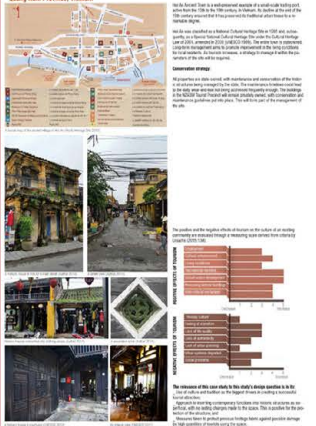


CHAPTER 4: CASE STUDIES & PRECEDENTS

CASE STUDY 1: The Bo-Kaap Cape Town, South Africa



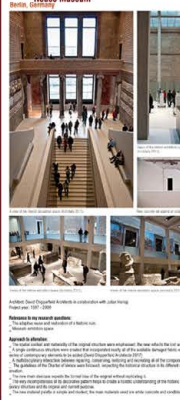
CASE STUDY 2: Ndi An Ancient Town Guang Zhou, Vietnam



PRECEDENT 1: HERITAGE: Hermitage Museum/ Stoharmer Barn



PRECEDENT 2: HERITAGE: Neues Museum



PRECEDENT 3: HERITAGE: Gallery House



**PRECEDENT 1: PROGRAMME: Visitor Centre Emscher Village**  
Dormaster, Germany

**PRECEDENT 2: PROGRAMME: Vilaça Street Precinct**  
Douro, Portugal

**PRECEDENT 3: PROGRAMME: Tourist House**  
Tombura, South Africa

### CHAPTER 5: DESIGN DEVELOPMENT

#### Design Informants

**CONTEXT AS INFORMANT**

**PRECIOUS HERITAGE FABRIC AS INFORMANT**

**SUMMARY OF FORM**

**PROGRAMME AS INFORMANT**

**THEORY AS INFORMANT**

**REGENERATION STRATEGY**

**CASE STUDIES AND PRECEDENTS AS INFORMANTS**

### CHAPTER 5: DESIGN DEVELOPMENT

#### Concept

**ABSTRACTION OF THE SHAPE OF A HOUSE**

**CONCEPTUAL APPROACH**

**A Inside-out approach:** Interior architecture as inspiration for the architecture and urban design. Design decisions are rooted in an analysis of heritage.

**B Heritage for all:** Precious heritage fabric in private residences is exposed to be accessible in the public realm.

**C Pockets of life:** Existing social, structural and natural conditions is taken into account for the creation of a three-dimensional experience of space.

### CHAPTER 5: DESIGN DEVELOPMENT

#### Vision for the urban landscape

**URBAN VISION: THE NZASM TOURIST PRECINCT**

**FUNCTIONAL KEY**

**LANDSCAPE KEY**

**SHARED PRIVATE DRIVES**

**TREE SHADYPANCE**

**GUIDELINES FOR THE DESIGN OF PUBLIC SPACE**

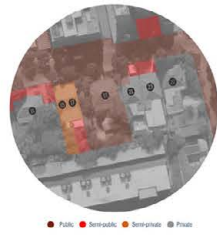
*Handwritten notes on public space design guidelines.*

CHAPTER 5: DESIGN DEVELOPMENT  
Vision for the cultural landscape

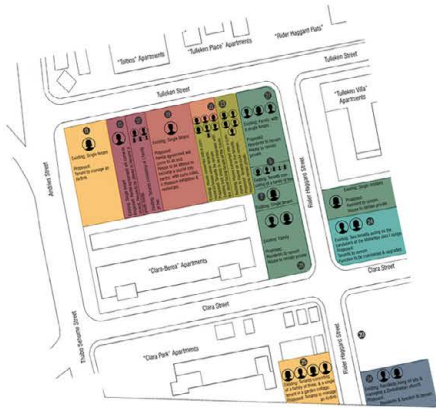
INDIVIDUAL APPROACH TO HERITAGE ALTERATION



DEGREES OF PRIVACY



SOCIAL VISION



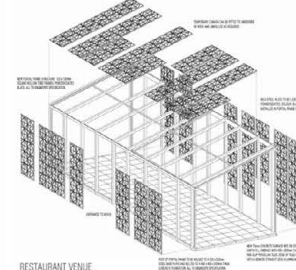
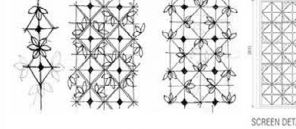
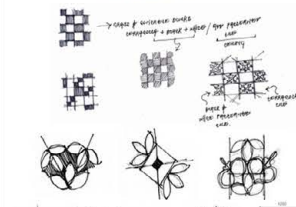
CHAPTER 5: DESIGN DEVELOPMENT  
Materiality



EXISTING MATERIALITY  
PROPOSED MATERIALITY



CHAPTER 5: DESIGN DEVELOPMENT  
Pattern Development



CHAPTER 5: TECHNICAL DEVELOPMENT  
Theoretical Approach

**Main Technical Question:**  
How can the approach to heritage fabric be presented in Chapter 2 to establish a strategy for the addition of new fabric, with the aim of achieving a meaningful change in character?

**Sub questions:**  
How 'heritage fabric' is described in preparation for new fabric, how will the form of the old be addressed?  
What approach will be undertaken to control old and new fabric?  
In an open-ended public, and a shared public space, what is the role of the architect in the design process?

**APPROACH TO TECHNICAL RESOLUTION:**  
These possible approaches can be taken to the alteration of heritage fabric: the way, the complementary and the control. Guidelines for these approaches have been considered through the theoretical approach of this chapter in preparation for Chapter 6 (December 2016). The outcomes of all the approaches for the old and new to become one without a loss of identity.

**The way:** The way consists of viewing the existing structure in terms of fabric. The inclusion of the type of material, form, pattern, proportion, scale, surface texture, technology, construction, material and its proportion with the existing. Within these 100% refers to the old, a building in which the many changes, through hands and cables enough, work, by their very nature, interesting and instructive and leading to a possible change.

**The control:** The control consists of creating new material to create a juxtaposition with the old. The control can be the type of material, form, pattern, proportion, scale, surface texture, technology, construction, material and its proportion with the existing. Within these 100% refers to the old, a building in which the many changes, through hands and cables enough, work, by their very nature, interesting and instructive and leading to a possible change.

**The complementary:** The complementary approach lies between the control and the old, and is a combination of the existing fabric. New fabric is chosen that will work hand-in-glove with the old, while complementing it in the type of material, form, pattern, proportion, scale, surface texture, technology, construction, material and its proportion.

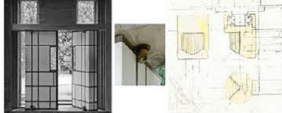
**FLOOR PLAN AT THE CASTLEVECHOU MUSEUM, VERDUN**  
Gavin Roper's treatment of the Castlevechou Museum's ground floor is an example of a complementary intervention. The new floor consists of a concrete slab finished with a stone-effect grout. Columns are stone and brick. The floor is made of different materials, creating a rich and varied texture. The floor is made of different materials, creating a rich and varied texture. The floor is made of different materials, creating a rich and varied texture.



ENTRANCE BRIDGE TO THE GUERRA STAMPAAL FOUNDATION, VENICE



CHAIRPL, LOOK MISS TO THE BRONZ CENTER, S. VITO DI ALTEVULTE



**HERITAGE ALTERATION AUDIT**  
**Guidelines for new material:**  
- Does the new material respect the character of the old?  
- Is the new material a copy, a contrast to, or does it complement the old?  
- Can the new material be used in a way that respects the old?  
- How will the new material age when compared to the old?  
- Can the addition of new material be reversed for the old?  
- Does the choice of new material meet the historical requirements?  
- Does the choice of new material comply with the wishes of the project and community?  
- How will the new material be joined to the old? Is the joining temporary or permanent and what is the impact on the old?

CHAPTER 5: TECHNICAL DEVELOPMENT  
Furniture Specification

LANDSCAPE FURNITURE



RESTAURANT FURNITURE



YOUTH HOSTEL FIRST FLOOR FURNITURE



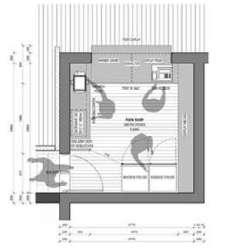
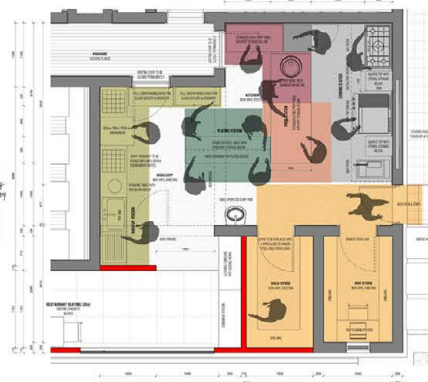
TUCKSHOP FURNITURE



CHAPTER 5: DESIGN DEVELOPMENT  
Restaurant kitchen, tuckshop and take-aways, and bar layout



Handwritten notes in Afrikaans and English detailing design considerations and specifications for the kitchen and bar areas.



CHAPTER 6: CONCLUSION

RECAPITULATION

The researcher's journey was the documentation and analysis of change that unfolded in the streets of the tourist precinct. The researcher's journey was the documentation and analysis of change that unfolded in the streets of the tourist precinct. The researcher's journey was the documentation and analysis of change that unfolded in the streets of the tourist precinct.

CHAPTER SUMMARIES

Chapter 1 presented an overview of the study, its objectives, and research questions. Chapter 2 explored the physical and social context of the study site. Through documentation and analysis of the area and historic context, a definition of significance was provided and a research framework was proposed. Chapter 3 developed theories for heritage education, including an interpretive strategy. A research strategy was developed, including the idea that a resident and sustainable community is a key to a successful heritage project. Chapter 4 presented an analysis of the study site, including an analysis of the study site, including an analysis of the study site. Chapter 5 presented an analysis of the study site, including an analysis of the study site. Chapter 6 presented an analysis of the study site, including an analysis of the study site.

CONCLUSIONS

The researcher's journey was the documentation and analysis of change that unfolded in the streets of the tourist precinct. The researcher's journey was the documentation and analysis of change that unfolded in the streets of the tourist precinct. The researcher's journey was the documentation and analysis of change that unfolded in the streets of the tourist precinct.

CONTRIBUTIONS

The researcher's journey was the documentation and analysis of change that unfolded in the streets of the tourist precinct. The researcher's journey was the documentation and analysis of change that unfolded in the streets of the tourist precinct. The researcher's journey was the documentation and analysis of change that unfolded in the streets of the tourist precinct.

RECOMMENDATIONS FOR FURTHER RESEARCH

The researcher's journey was the documentation and analysis of change that unfolded in the streets of the tourist precinct. The researcher's journey was the documentation and analysis of change that unfolded in the streets of the tourist precinct. The researcher's journey was the documentation and analysis of change that unfolded in the streets of the tourist precinct.









## THANK YOU

My study leader, Catherine

My husband, Wichard

My parents, Zanie and parents-in-law

Antonette, Leandra and Mark

Neo Dimensions Architects

