

The Purification Works

Architecture as a restitutor of Industrial heritage and Ecology



Submitted in fulfillment of part of the requirements for the degree in Magister in Architecture
(Professional) at the Department of Architecture in the Faculty of Engineering, Built Environment and
Information Technology

University of Pretoria
2017

Study Leader: Prof. Piet Vosloo
Course Coordinator: Dr Arthur Barker

Author: Jan-Paul du Plessis
16064845

Abstract

This dissertation aims to propose an appropriate architectural intervention within a site that requires both ecological restitution and the commemoration of industrial heritage. The Johannesburg Gasworks site serves as a clear example of how the Industrial Revolution and subsequent industrial technologies have both damaged the natural environment and left blighted legacies within ever developing urban conditions.

The project aims to uphold the general significance of Industrial heritage as proposed by charters such as the Nizhny Tagil charter prepared by The International Council for the Commemoration of Industrial Heritage as well as the unique heritage significance of the Gasworks site. An appropriate theoretical framework and precedents are explored that reconcile the two seemingly opposing requirements of post-industrial sites - that of commemoration and ecological restitution. In post-industrial sites scarred by water, soil and air pollution, as well as dangerous or inaccessible places, maintaining an appreciation of heritage whilst employing the various rehabilitative actions required need to be balanced to ensure both.

The project undertaken forms part of four schemes proposed for the site that aim to maintain the iconic identity of the Johannesburg Gasworks by proposing ecologically sensitive industries. These industries and interventions within the site aim to bring about urban resilience, site specific environmental rehabilitation as well as integration with the surrounding urban context. The proposed project for the site draws its program from global ecological issues as well as site specific heritage factors. The aim of scripting a new layer of intervention onto the Gas Works site is to make a legible reading between the site's history and its ecologically resilient future legacy.

Project Summary

Site description: The Johannesburg Gasworks also known as Egoli Gas

Site location: Corner of Barry Hertzog Street and Annet Road
Cottesloe, Johannesburg
26°11'23.34" S 28°01'15.10" E

Programme: Aquaculture & Fish feed production facility

Research Field: Heritage and Cultural Landscapes

Keywords: Aquaculture, Post-industrial, Site remediation

Special thanks

First and foremost, the living Christ for making me alive.

My mother and father for continuous support

John Mayer, King's Kaleidoscope, Skurwe abrahams rusks and the entire Egoli Gas Works team

Index

Preface

Title Page.....	i
Abstract.....	ii
Special thanks.....	iii
List of Figures.....	iv

Chapter 1 - Introduction

Page no

1.1 Introduction.....	1
1.2 General issues.....	2
1.3 Urban issues.....	3
1.4 Architectural issues.....	4
1.5 Research questions.....	5
1.6 Research methods.....	6

Chapter 2 - The Site, The Johannesburg Gas Works

2.1 Site location.....	9
2.2 Site morphology.....	11
2.3 History of the Gas Works.....	13
2.3.1 Inception and early days.....	14
2.3.2 Years of growth and eventual shutdown.....	16
2.3.3 The Gas Works and cooking.....	17
2.4 Gas production from coal.....	19
2.5 Present day zoning.....	27
2.6 Present day condition of industrial core.....	29
2.7 Unpacking the immediate site (the identification of order and place).....	32
2.7.1 Identifying zones and place.....	32
2.7.2 Broken coherence.....	33
2.7.3 The spatial logic of industry.....	34
2.8 Understanding the urban condition.....	35
2.8 Responding to the urban condition.....	39

Chapter 3 - Appropriate theoretical framework

3.1 Introduction.....	43
3.2 TICCIH.....	45
3.3 The Japanese Wabi-Sabi aesthetic.....	46
3.4 Reconstruction and commemoration.....	47
3.5 Genius Loci “the spirit of a place”	48
3.6 The site as palimpsest.....	49

Chapter 4 - Precedents

4.1 Crissy Field, San Francisco Bay.....	53
4.2 Landscape Park Duisburg-Nord, Duisburg, Germany.....	55
4.3 Turbine hotel, Knysna, South Africa.....	56
4.4 Westergasfabriek, Amsterdam, the Netherlands.....	56
4.5 Parc de la Cour du Maroc, Paris.....	57
4.6 Fresh kills park, New York.....	57
4.7 The plant, Chicago.....	58
4.8 Conclusion.....	58

Chapter 5 - Programme

5.1 Identifying the appropriate programme.....	61
5.1.1 Heritage and legacy.....	61
5.1.2 The restitution of industry with ecology on the Gas Works site.....	61
5.1.3 The presence of water.....	62
5.1.4 Promoting sustainable urbanism.....	63
5.1.5 Connection with established networks.....	63
5.1.6 The Gas Works and cooking.....	64
5.1.7 Conclusion.....	65
5.2 Magmeal - an Innovative solution as precedent.....	68
5.3 Programme areas schedule.....	71
5.4 Programme allocation.....	73

Chapter 6 - Conceptual development

6.1 Conceptual intention 1: The extension of industry.....	77
6.2 Conceptual intention 2: Responding to the grid.....	79
6.3 Conceptual intention 3: movement along the grid.....	80
6.4 Conceptual intention 4: Water-based recreation.....	81
6.5 Conceptual intention 5: Cohesion through geometric order.....	82
6.6 Conceptual intention 6: Overlaid geometry.....	83
6.7 Synthesis of conceptual intentions.....	84
6.8 Place-specific conceptual approaches.....	85
6.9 The layering of intervention.....	87

Chapter 7 - Design development

7.1 Intervention layer one - remedial action.....	91
7.2 Intervention layer two - commemorate demolished structures.....	97
7.2.1 The purification plants.....	99
7.2.2 Appropriate commemoration.....	101
7.3 Intervention layer three - formal heritage responses.....	105
7.3.1 Overall intervention area.....	107
7.4 Intervention layer four - programmatic responses.....	109
7.4.1 No 3 gas tank.....	111
7.5 Design explorations.....	113
7.5.1 Design iteration 1.....	115
7.5.2 Design iteration 2.....	117
7.5.3.1 Design iteration 3, building 1.....	119
7.5.3.2 Design iteration 3, building 2.....	121
7.5.4 Design iteration 4. elevations.....	123
7.6 Facade analysis as design informant.....	125
7.7 Iteration five design drivers and resolution.....	127

Chapter 8 - Technical resolution

8.1 Technological heritage analysis of the Gas Works	
8.1.1 Material palette.....	141
8.1.2 Construction techniques and details.....	143
8.1.3 Translating elements from heritage into design.....	145
8.2 Climatic analysis.....	147
8.3.1 Structural system building 1.....	149
8.3.2 Structural system building 2.....	151
8.4.1 Passive ventilation building 1.....	153
8.4.2 Passive ventilation building 2.....	155
8.4.3 Geothermal piping and ventilation strategy.....	157
8.5 Construction detailing.....	159
8.6 Daylighting iterations.....	165
8.7 Rainwater harvesting calculations.....	167

List of figures

- figure 1. Site location. Image by Author (2017)
- figure 2. Ecological condition. Image by Author (2017)
- figure 3. Industrial condition. Image by Author (2017)
- figure 4. Post-industrial condition. Image by Author (2017)
- figure 5. Original Plan of Gas Works, 1929. Tsica heritage consultants archives (2017), edited by author
- figure 6. View of Gas Works from Annett road looking east, 1929. Tsica heritage consultants archive (2017)
- figure 7. Holmden's street map of Johannesburg and suburbs. City of Johannesburg map office (1929) edited by author
- figure 8. Gas storage tank of President street Gas Works. Tsica heritage consultants archives (2017)
- figure 9. Purifiers at President Street Gas Works. Tsica heritage consultants archives (2017)
- figure 10. No 1&2 gas tanks of new Cottlesloe site. Tsica heritage consultants archives (2017)
- figure 11. Photograph of Purification plant, 1929. In: Lauferts le Roux, M. & Mavunganidze, J. 2015. The Johannesburg Gas Works. 1st ed. Johannesburg: Fourthwall.
- figure 12. Aerial photograph of Gas Works site, 1960. In: Lauferts le Roux, M. & Mavunganidze, J. 2015. The Johannesburg Gas Works. 1st ed. Johannesburg: Fourthwall.
- figure 13. Mr Therm, the mascot for Egoli Gas. In: Lauferts le Roux, M. & Mavunganidze, J. 2015. The Johannesburg Gas Works. 1st ed. Johannesburg: Fourthwall.
- figure 14. The liquid Ammonia collection area. In: Lauferts le Roux, M. & Mavunganidze, J. 2015. The Johannesburg Gas Works. 1st ed. Johannesburg: Fourthwall.
- figure 15. A cookery demonstration at the showroom of the Gas Works. In: Lauferts le Roux, M. & Mavunganidze, J. 2015. The Johannesburg Gas Works. 1st ed. Johannesburg: Fourthwall.
- figure 16. Gas stove cooking. istock. 2017. Signature. <http://media.istockphoto.com/photos/man-tossing-fresh-vegetables-in-saucepan-picture-id477000030?k=6&m=477000030&s=612x612&w=0&h=fGHsh7hks-WrBefp5ruuNTNEtpsDf2BfhJlQFCdWYXU=> (Accessed 12 October 2017)
- figure 17. longitudinal section through Retort House 1. Tsica heritage consultants archives (2017)
- figure 18. Retort House 1 with condensers in foreground. Tsica heritage consultants archives (2017)
- figure 19. Plan of structures involved in process and direction of energy flow. Image by Author (2017)
- figure 20. condensers (item 9) in their current state. Photograph by Author (2017)
- figure 21. Livesey and rotary multifilm Washers (item 11) with purifier (item 14 on plan) shown in background. Tsica heritage consultants archives (2017)
- figure 22. Plan of structures involved in process and direction of energy flow. Image by Author (2017)
- figure 23. View towards Retort No.1 & 2. Tsica heritage consultants archives (2017)
- figure 24. View of the No 1,2 and 3 gas storage tanks. Tsica heritage consultants archives (2017)
- figure 25. View towards easternmost purification plant. Tsica heritage consultants archives (2017)
- figure 26. View on tar distillation plant_1950. In: Lauferts le Roux, M. & Mavunganidze, J. 2015. The Johannesburg Gas Works. 1st ed. Johannesburg: Fourthwall.
- figure 27. Pollution distribution diagram. Image by Author (2017)

figure 28. Aerial of the Gas Works site from the 1950s. Tsica heritage consultants archives (2017) edited by author

figure 29. Aerial of the Gas Works site. Tsica heritage consultants archives (2017) edited by author

figure 30. Identifying zones and place. Image by Author (2017)

figure 31. Zones of industry, sequence of industry and demolished structures. Image by Author (2017)

figure 32. Demolished structures and their role within the sequence of the industrial process. Image by Author (2017)

figure 33. The linear sequence of the original coal to gas process. Image by Author (2017)

figure 34 View towards Retort 1 through No 1&2 gas tanks. Tsica heritage consultants archives (2017)

figure 35. The urban condition in contrast. Image by Author (2017)

figure 36. Gas Works urban vision plan. Image by Johannesburg Gas Works group (2017)

figure 37. Noteworthy heritage aspects of the Gas Works site. Image by Author (2017)

figure 38. Wabi-Sabi application on the Gas Works site. Image by Author (2017)

figure 39. Noteworthy aspects of demolished structures. Image by Author (2017)

figure 40. Genius Loci of the Gas Works site. Image by Author (2017)

figure 41. The layering of the Gas Works site and reading the intervention area as the location of overlap. Image by Author (2017)

figure 42. Reading a site as a palimpsest. Image by Author (2017)

figure 43. Layers of intervention at Crissy Field. Sketch by Author (2017)

figure 44. Crissy Field. Airport2Park. 2014. Crissy Field. <http://airport2park.org/portfolio-item/crissy-field/> (Accessed 12 October 2017)

figure 45. Park Duisburg Nord, Latz+Partner. Mellado, J.A.C. [Sa]. <https://za.pinterest.com/pin/347832771193086641/> (Accessed 27 July 2017)

figure 46. layers of intervention at duisburg-Nord. Image by Author (2017)

figure 47. Turbine hotel in Knysna, South Africa. Baker. 2012. <http://www.stayreview.com/turbine-hotel-in-knysna-south-africa/> (Accessed 16 October 2017)

figure 48. Cultuurpark Westergasfabriek. Gustafson, Porter + Bowman. 2017. <http://www.gp-b.com/cultuur-park-westergasfabriek> (Accessed 16 October 2017)

figure 49. Parc de la cour du maroc. Kopinski, J. [Sa]. Les Jardins d'Eole Parc de la Cour du Maroc. <https://za.pinterest.com/pin/159314905545751490/> (Accessed 27 July 2017)

figure 50. Fresh kills park. Ecowatch. 2017. New York Transforms World's Largest Landfill Into City's Biggest Solar Array. <https://www.ecowatch.com/new-york-transforms-worlds-largest-landfill-into-citys-biggest-solar-a-1881830086.html> (Accessed 16 October 2017)

figure 51. Garden and mural. Plant Chicago. 2014. <https://www.flickr.com/photos/plantchicago/14400906158/> (Accessed 28 September 2017)

figure 52. The Gas Works site in relation to the nearby campus and public restaurants. Image by Author (2017)

figure 53. Program designation showing core, sub- and supporting functions. Image by Author (2017)

figure 54. Areas schedule. Image by Author (2017)

figure 55. Area function allocation. Image by Author (2017)

figure 56. Layout of programme on intervention area. Image by Author (2017)

figure 57. The link between Industry and Ecology. Image by Author (2017)

figure 58. Building 1 as extension of heritage narrative. Image by Author (2017)

figure 59. Building 1 as conceptualized mass on site. Image by Author (2017)

figure 60. Responding to the grid as conceptual response. Image by Author (2017)

figure 61. Movement along the grid as conceptual response. Image by Author (2017)

figure 62. Water-based recreation and conceptual response. Image by Author (2017)

figure 63. Cohesion through geometric as conceptual response. Image by Author (2017)

figure 64. Overlaid geometry as conceptual response. Image by Author (2017)

figure 65. Synthesis of conceptual intentions. Image by Author (2017)

figure 66. The intervention zones. Image by Author (2017)

figure 67. The intervention area. Image by Author (2017)

figure 68. The layers of intervention. Image by Author (2017)

figure 69. Erosion and pollution location and intensity. Image by Author (2017)

figure 70. Hole 1 edge condition. Photograph by Author (2017)

figure 71. Tar pollution within soil. Tsica heritage consultants archives (2017)

figure 72. Sketch illustrating soil displacement at tank 1's construction, the present condition of hole 1 and the future conditions. (author, 2017)

figure 73. Hole 1 and 2 sketch. Image by Author (2017)

figure 74. Photograph of hole 1 edge. Photograph by Author (2017)

figure 75. Diagram of pollution on site. Image by Author (2017)

figure 76. Section through hole 2 indicating pollution and remedial actions. Image by Author (2017)

figure 77. Pre-industrial, mid-industrial and proposed post-industrial conditions. Image by Author (2017)

figure 78. Possible interventions within gas tank holes. Image by Author (2017)

figure 79. Demolished structures and their location. Image by Author (2017)

figure 80. Sketch indicating position of five purification plants. Image by Author (2017)

figure 81. Dry purification plant_1929. Tsica heritage consultants archives (2017)

figure 82. Construction drawings for purification plant. Tsica heritage consultants archives (2017)

figure 83. Column stubs. Photograph by Author (2017)

figure 84. Purification box inside plant. Tsica heritage consultants archives (2017)

figure 85. Gas plant_Cottesloe_1950_dry purification plant. Tsica heritage consultants archives (2017)

figure 86. Formal heritage responses. Image by Author (2017)

figure 87. Identifying order. Image by Author (2017)

figure 88. Design explorations as response. Image by Author (2017)

figure 89. Programmatic responses. Image by Author (2017)

figure 90. Model exploration 1: Rebuilt topography as means of commemoration and reflection. Image by Author (2017)

figure 91. Model exploration 2: Interplay between rectilinear and circular form. Image by Author (2017)

figure 92. Model exploration 3: Structure, scale, placement and the nature of the stair. Image by Author (2017)

figure 93. Design iteration one with re-appropriated Gas tank no.3. Image by Author (2017)

figure 94. Design iteration 2. Image by Author (2017)

figure 95. Design iteration four, elevations. Image by Author (2017)

figure 96. Facade analysis of Building 1 and Retort no. 2. Image by Author (2017)

figure 97. Facade analysis of building 2 and Retort no. 1. Image by Author (2017)

figure 98. Design drivers. Image by Author (2017)

figure 99. Scheme plan (Author, 2017)

figure 100. Building 1 first floor plan (Author, 2017)

figure 101. Building 1 ground floor plan (Author, 2017)

figure 102. Building 2 square level plan (Author, 2017)

figure 103. Building 2 service level plan (Author, 2017)

figure 104. Building 2 park level plan (Author, 2017)

figure 105. Southwestern elevation (Author, 2017)

figure 106. Northeastern elevation (Author, 2017)

figure 107. Building 2 Southeastern elevation. scale 1:200 (Author, 2017)

figure 108. Building 1 cross section (Author, 2017)

figure 109. Building 2 Longitudinal section (Author, 2017)

figure 110. Northwestern elevation. scale 1:200 (Author, 2017)

figure 111. Close-up photograph of Livesey scrubber. Photograph by Johannesburg Gas Works group (2017)

figure 112. Steel structure in Retort 2 interior. Photograph by Johannesburg Gas Works group (2017)

figure 113. Livesey washer deconstructed envelope and piping exposed. Photograph by Johannesburg Gas Works group (2017)

figure 114. Western entrance to Retort No. 1. Photograph by Johannesburg Gas Works group (2017)

figure 115. CWG plant eastern elevation with structure expressed in facade. Photograph by Johannesburg Gas Works group (2017)

figure 116. Retort no. 1 western facade with brick-clad cross bracing expressed. Photograph by Johannesburg Gas Works group (2017)

figure 117. Opening detail of Retort no. 2 northern facade. Photograph by Johannesburg Gas Works group (2017)

figure 118. Steel structure of Retort No. 1. In: Lauferts le Roux, M. & Mavunganidze, J. 2015. The Johannesburg Gas Works. 1st ed. Johannesburg: Fourthwall.

figure 119. South-eastern facade of Retort No. 1. Tsica heritage consultants archives (2017)

figure 120. 3D digram illustrating facade detailing of Retort no. 1 & 2. Image by Author (2017)

figure 121. Steel and concrete junctions of Retort No. 1. In: Lauferts le Roux, M. & Mavunganidze, J. 2015. The Johannesburg Gas Works. 1st ed. Johannesburg: Fourthwall.

figure 122. Concrete detailing around openings and strucural expression. Photograph by Johannesburg Gas Works group (2017)

figure 123. Chimney towers, the relationship between openings and structure. Photograph by Johannesburg Gas Works group (2017)

figure 124. Brick eave detailing. Photograph by Johannesburg Gas Works group (2017)

figure 125. Chimney flues of Retort 1. Photograph by Johannesburg Gas Works group (2017)

figure 126. Construction elements of Gas Works site deconstructed. Image by Author (2017)

figure 127. Wind direction distribution of Johannesburg showing 12 months overlaid. Windfinder. 2017. https://www.windfinder.com/windstatistics/Johannesburg_or_tambo_airport (Accessed 26 September 2017) edited by Author

figure 128. Summer solstice shadow paths. Image by Author (2017)

figure 129. Winter solstice shadow paths. Image by Author (2017)

figure 130. Climatic analysis with September solstice shadow paths. Image by Author (2017)

figure 131. Structural system of Building 1. Image by Author (2017)

figure 132. Reference plan for Building 1. Image by Author (2017)

figure 133. Structural system of Building 2. Image by Author (2017)

figure 134. Reference plan for building 2. Image by Author (2017)

figure 135. Trombe wall detail at scale 1 to 50. Sketch by Author (2017)

figure 136. North-eastern elevation showing continuity between Trombe wall and external stair in elevation at scales 1 to 200 and 1 to 100. Sketch by Author (2017)

figure 137. Building 2 cross-section showing passive ventilation strategy at scale 1 to 100. Sketch by Author (2017)

figure 138. South-eastern elevation of building 2 showing Trombe wall sytem as implemented in the facade Sketch by Author (2017)

figure 139. Trombe wall detail at scale 1 to 50 showing possibilities of implementation at either level. Sketch by Author (2017)

figure 140. The implementation of geothermal earth-tubes (Author, 2017)

figure 141. The implementation of Corobrik external angle 45 brick into building facade. Image by Author (2017)

figure 142. Recessed brickwork as a means of solar control. Image by Author (2017)

figure 143. Recessed brickwork and the effect on building 1's facade. Image by Author (2017)

figure 144. Building 2 detail section through southern facade (author, 2017)

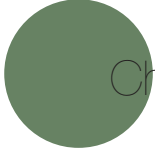
figure 145. Building 1 baseline over/under-lit study (Sefaira, 2017 and edited by author)

figure 146. Building 2 baseline over/under-lit study (Sefaira, 2017 and edited by author)

figure 147. Rainwater harvesting strategy. Image by Author (2017)

List of tables

table 1. Rainwater collection. Table by Author (2017)



Chapter 1





1.1 Introduction

Industry and Ecology have mostly had a mutually exclusive relationship for the last 250 years. The development of the steam engine in 1769 served as the trigger for industrialization (Krinke, 2001) and the mechanization of production processes whilst the perception of unobstructed progress was propelled by a willful ignorance of the legacy left on the natural environment. Although planet Earth and its resident ecology has since revealed its own limits on resource provision and pollution tolerance, the decades of unawareness on this issue have caused the “inexhaustible earth” mindset to gain tremendous momentum - a momentum proving difficult to halt and reverse. The need for this reversal is made prevalent by witnessing the legacy of Industrialization whether it is acidified streams, airborne toxins or soil pollution. Of course, industrialization has made major advances possible for society in terms of goods production and many other sectors and therefore it is not suggested that industrialization is inherently bad but rather that a certain callousness towards ecological matters have necessitated steering industry in a more sustainable direction.

However, by the term “Industrialization” much broader associations must be drawn than the extraction and processing of raw natural materials for the mechanized production of products. In fact, since the pre-industrial society was an agricultural society, it follows that the rapid growth in technology has led to the industrialization of agricultural and food systems as well (Millstone, et al., 2003). Although the advantages of mechanizing the agricultural and food systems have appealed to the human desire for convenience, efficiency and replicable standards, these very advantages often necessitate the monopoliza-

tion of the agricultural and food industries.

This separation between the producer and the consumer has never been farther although there has been a recent shift to bridge this divide as people realize the insensitive and domineering approach towards ecology (Crawford, 2012). The legacy also entails physical remains in our built environments that serve as a plethora of earlier built interventions around which, through which and in which design practitioners must work. Polluted natural resources such as water bodies and soil are also tangible remnants that require various remedial actions. Whether the legacy of industrialization is “tangible”, referring to artifacts and blighted landscapes in our cities or “intangible” referring to consumerist mindsets, the relationship between industry and ecology has traditionally been at odds and in need of restitution.



1.2 Background

The general issue addressed in this dissertation is the relationship between ecology and the legacy of industry. More specifically, it deals with the necessary restitution on a site where the processing of raw materials into a product has left a damaging legacy on the indigenous ecology. This issue can be witnessed in the old Johannesburg Gas Works site in Cottesloe, Johannesburg. The Gas Works epitomizes dominion over the natural environment and the persuasion that the Earth is limitlessly resilient in handling pollution brought about by industry. Since gas production at the plant had started in 1928, the Gas Work's impact on the natural environment has been pervasive and it's shutdown in 1988 is partly owing to concerns regarding its ecological impact that includes severe tar pollution within the soil (International, 2006).

The shutdown of the Gas Works was also owing to the inherent brevity and contingency of any particular industry. This dissertation investigates and understands ecology in reaches that extend to global issues and not merely to the immediate ecological issues of this site. On a global scale, the issue that pertains to industry and ecology that will be localized to this site is the manner in which the industrialized agriculture and food industry has put enormous pressure on ecology (especially oceanic fish stocks) to supply the demand of the world's growing population.

In terms of water demand, Africa uses more than 80% of its freshwater supply for agricultural purposes, more than the Americas and Asia (Agriculture, 2017). Furthermore, 2016 has been South Africa's driest year ever recorded and the country is yet to recover (Live, 2016). The urbanization rate and population growth rate of 2% per year of Johannesburg (City of Johannesburg 2016) as well as the depletion of freshwater and ecological resources places the pressure on industry in South Africa and the world to progress in a manner that illustrates the possibilities of a restituted mutually beneficial relationship between industry and ecology.

The placement of the Johannesburg Gas Works may seem arbitrary considering its dense urban surroundings, but in the 1920s the site was chosen for its favourable topography that would render the site invisible from the affluent neighbourhoods of Parktown and Westcliff but visible from the poorer neighbourhoods of Cottesloe and Vrededorp (Lauferts le Roux & Mavunganidze, 2015). The Gasworks ceased gas production in 1988 and because of the rapid growth of Johannesburg to the North, this 14 hectare site sits isolated within the dense urban fabric surrounding it. Since the site is privately owned and hazardous to the public it is completely shut off from its surroundings.

Considering the large open space that the site currently occupies as well as its potential in terms of biodiversity (stemming from its location within the Braamfontein Spruit basin), the Gas Works site has tremendous potential to serve as an open green space within a dense urban environment where open spaces are typically fragmented, privatized or dangerous. However, its scale and location also make it a prime development opportunity and thus there is a tension regarding the site's next stage of development.

The pressure on the Gas Works site to be developed stems from its location within the future regional node of Milpark as part of a East-West business corridor. The potential of the site as a recreational open space stems from its location between Wits University, the University of Johannesburg and John Orr Technical school. Therefore, the urban issue deals with the pressure to meet the demand of development as well as open ecological space in such a way that the Johannesburg Gas Works site serves as a catalytic precedent in showcasing the harmony between these two necessities that are typically at odds in Johannesburg. If this can be done in a way that celebrates the unique heritage of this particular site, the people of Johannesburg can take recognition of the unique industrial inception of their city.

“Architecture is the instrument for manipulating our perception of the world in this way. It is by means of architecture that an architect mediates between the person and their surroundings...” (Unwin, 2015:108-109). Every work of architecture communicates its attitude towards its natural environment and this is especially the case in the Johannesburg Gas Works. Since the Gas Works employed advanced technology for its day, the architecture is a proud authoritative showcasing of its identity as a pioneer of industry in South Africa.

The proud showcasing of progress and industry makes the architecture Futurist in its inception and rhetoric. The rhetoric of futurism in architecture is to illustrate a vision - a vision of a modernized, industrial future where the innovation of man has conquered his environment. This, of course has been found to be unsustainable. Inevitably, the vision of smoke-filled skies as depicted in Art-Deco futurist reliefs are no longer a desirable vision for the future (Lauferts le Roux & Mavunganidze, 2015). The mono-functional purpose of the Gas Works and the redundancy of the coal to gas process has given the buildings on site the inevitable destiny of becoming historical artifacts.

The architectural issue is thus two-fold. Firstly, these artifacts and remnants of the industrial Revolution in South Africa have to be understood for their heritage significance and appropriately commemorated and secondly, the architecture must communicate a more resilient and responsible industry in line with the illustration of a future vision.

The architectural issue has become a new “futurism” - the new vision for the future. A future vision informed by a much more wholesome view of the planet we build on and the sustainability of mankind's residence here.

1.5Research Questions

The question that the research will aim to answer is: Can architecture, through both its programmatic and spatial realization, sustain and illustrate the restituted relationship between ecology and industry? The sub-question to this will be: Can this be done in such a way that the architecture becomes didactic - forming a connection in the mind of the public between the heritage of industry and the new industry? Can new architectural interventions assist in binding spaces disrupted by demolition to restore order and meaning to post-industrial places?

The question more specific to this dissertation is site specific. The most ecologically sensitive location on the Gas Works site are the holes where the first two gas tanks were located. These holes symbolize the damaging legacy of industry on the ecology of the site and it therefore has the potential to narrate a restored relationship as a powerful statement of restitution. Can architecture and appropriate programmes make this restitution possible within the location where the holes are located? The sub-question to this is: can this be done in such a way that the industrial heritage of the site as well as the ecological history of the site is overlaid as a palimpsest through which memory of damage and industry is displayed?

1.4.1 ASSUMPTIONS

The scheme will work with two basic assumptions-architectural and operational. The architectural assumption will be that the gas storage tanks on site can be re appropriated and are no longer vital for storing gas. Also, it is assumed that the gas distribution pipeline can be moved to a different location on the site and that the only buildings worth keeping based on a heritage assessment are the two red brick retort buildings, the coal bunkers, Carburetted Water Gas plants and the foundations of the three tanks. The operational assumption is that Egoli Gas can move offices to another location on the site and that the company has made the site available for development.

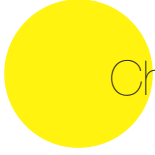
1.4.2 RESEARCH METHODOLOGY

The research will be conducted through visits to the site and documenting the condition of the footprints of the No.1 and No.2 gas tanks. Theory will be sourced that pertains to the ecological restoration of post-industrial landscapes. This will be sourced by desktop research and literature regarding post-industrial natural spaces. Appropriate theories will be sourced that pertain to industrial heritage, restoration and commemoration in architecture and the recall of memory of place in new architectural or landscape interventions. Design research will then subsequently involve architectural model explorations on the site to represent the conclusions found in the theory.

1.4.3 DELIMITATIONS & LIMITATIONS

This architectural proposal is delimited to a specific zone within the entire Egoli Gas site. Similar issues in other locations on the site are not addressed since the project in this dissertation is one of four architectural proposals and one landscape architecture proposal that specifically deals with the remediation of a large portion of the site. The chosen site has the potential to communicate the relationship between ecology and the heritage of industry most clearly. Although the scheme incorporates the gas distribution plant as a museum, other buildings of significant heritage value are not addressed since they fall within the territory of other proposals.

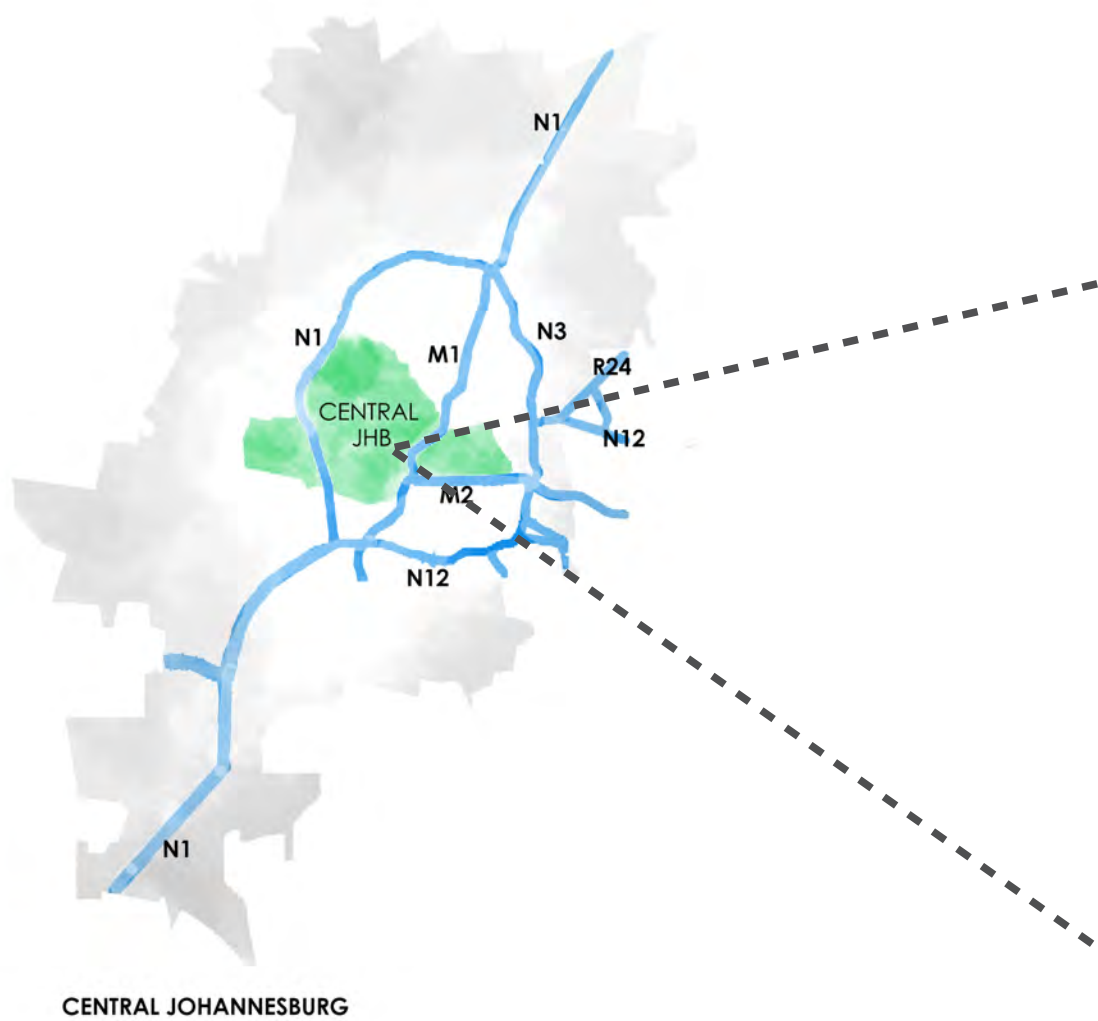
Other limitations within this scheme deal with the rehabilitation of the natural environment. Since the site of intervention is affected by tar pollution there are certain areas in which architectural interventions are not possible or where the interventions will be strictly guided by the remediative processes of tar pollution.

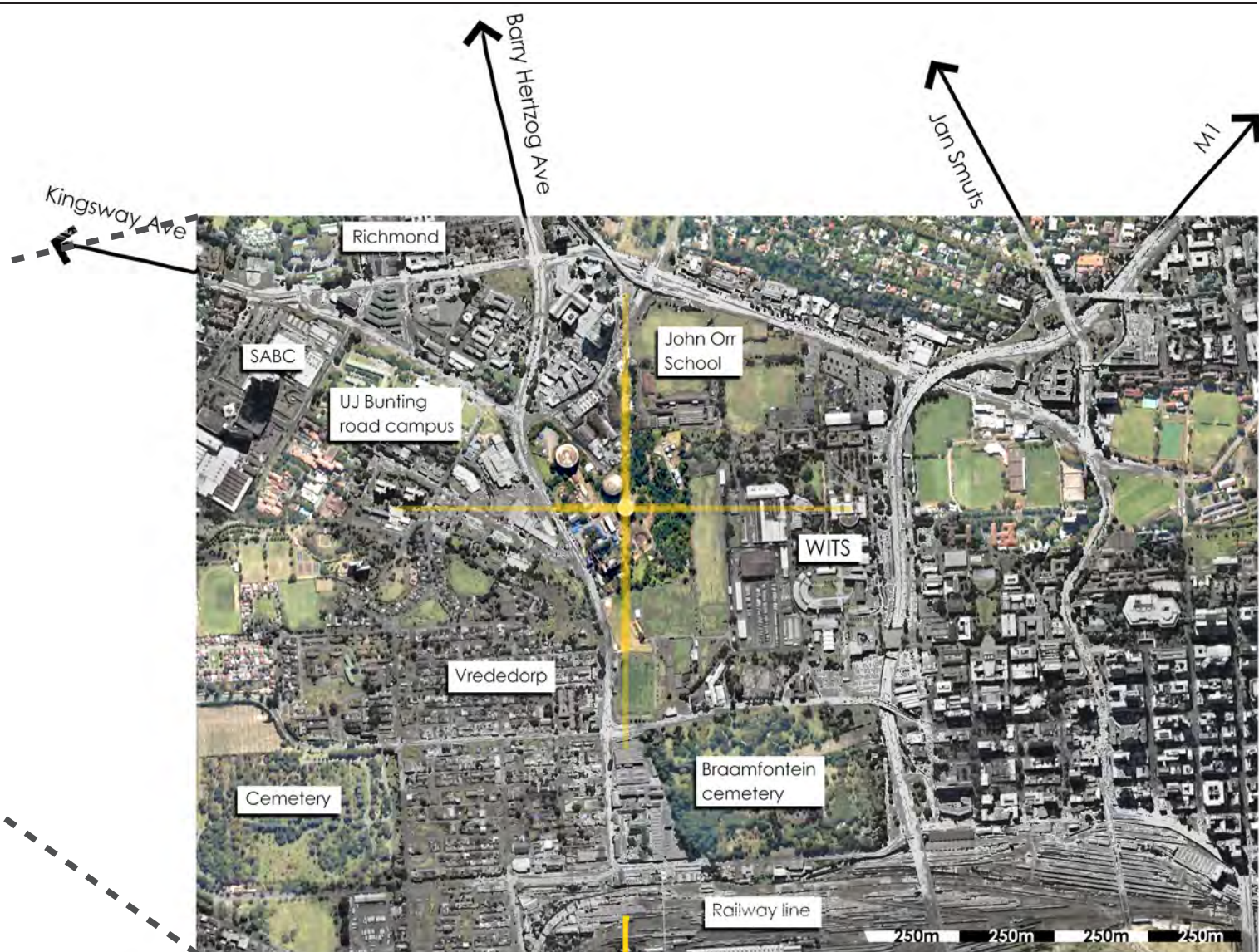


Chapter 2

The Site: The Johannesburg Gas Works

2.1 Site Location





Bottom left: **Figure 2** Ecological condition (Author, 2017)

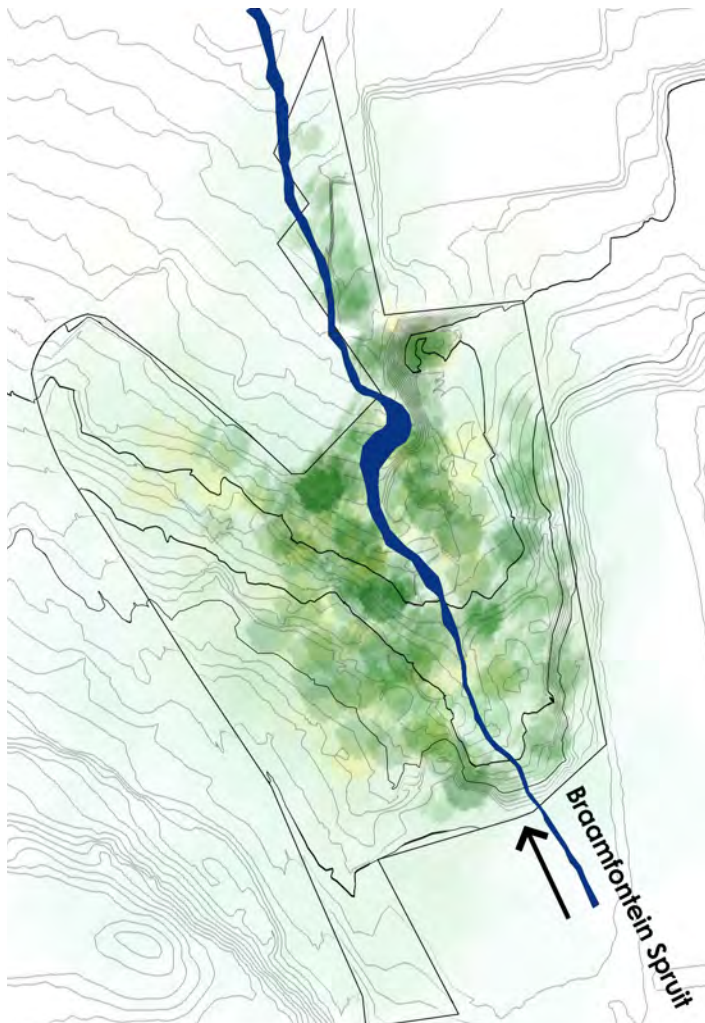
Bottom right: **Figure 3** Industrial condition (Author, 2017)

Far Right: **Figure 4** Post-industrial condition (Author 2017)

2.2 Site Morphology

Ecological Condition (Prior to 1926)

Site features: The site's topography forms a basin-like valley within which the Braamfontein Spruit flows northward, from its source near the Braamfontein cemetery and joining other tributaries further North.



Industrial Condition (1928-1988)

Site features: The site's topography was found to be favourable for the coal to gas plant since the slope could facilitate the flow of runoff fluids and gas towards the gas storage tanks at the site's lowest point. The Braamfontein Spruit is channeled in an underground stormwater pipe to protect it's water from pollution.



Current Post-Industrial Condition

(1992-present)



2.3 The History of the Gas Works

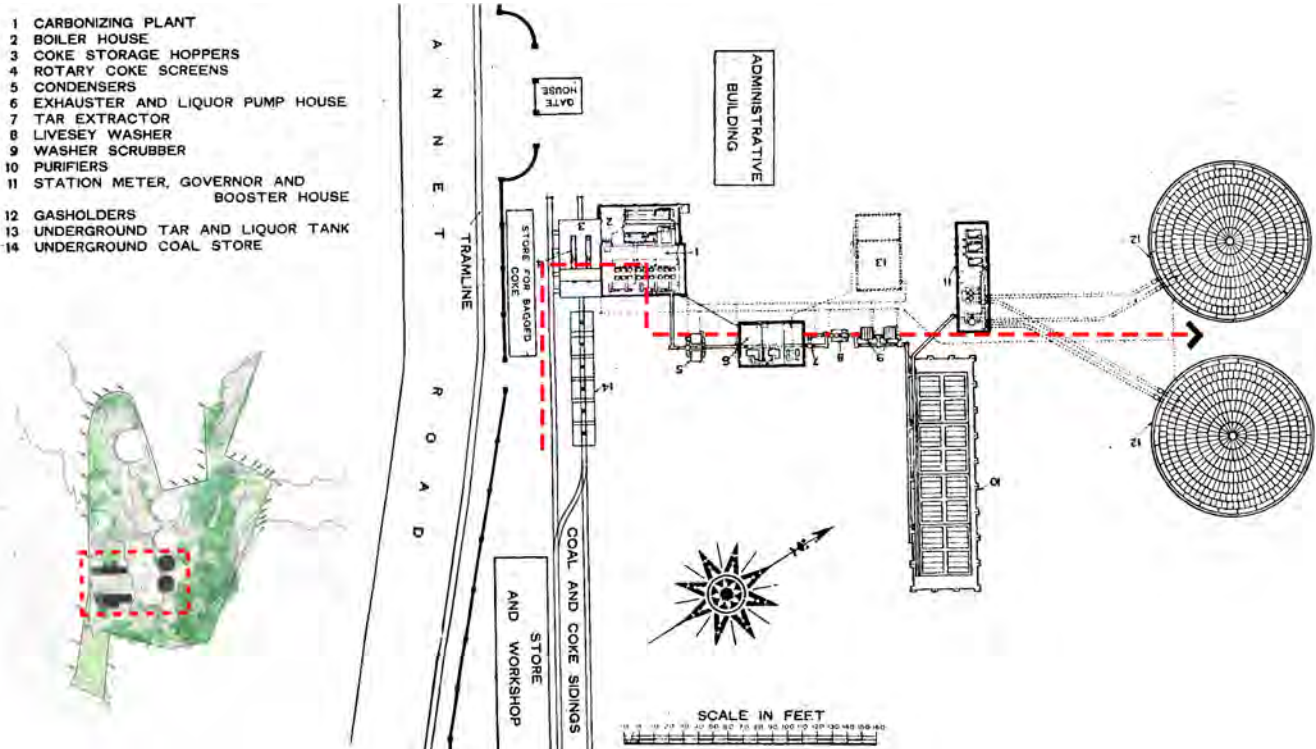


Figure 5 Original Plan of Gas Works, 1929 (Tsica archive, 2017) edited by author

Figure 6 View of Gas Works from Annett road looking East, 1929 (Tsica archive, 2017)





Figure 7 Holmden's street map of Johannesburg and suburbs (Map office, 1929) edited by author

2.3.1 Inception and early days

In the late 19th century for the then mining camp of Johannesburg, gas was initially supplied to meet the insatiable demand for power (Lauferts le Roux & Mavunganidze, 2016). In 1888 President Paul Kruger signed a concession leading to the construction of the first Gas Works site in President Street in 1892, four years after the first plant in South Africa at the Cape Town Gas Works. The need for expansion led to the search for a more suitable site and by 1928 the Gas Works moved to a site in Cottesloe. The site was a favourable choice due its topography since it could firstly assist in the gravity flow of gas and run-off fluids and secondly, render the largest structures on site relatively invisible from the richer neighbourhoods to the North. As can be seen in Figure 7, the site is situated about 3km from the then city

centre which was a location far enough that the Gas Works could be relatively inconspicuous, but close enough to supply gas to its immediate surroundings. The original role of the Gas Works was to supply gas for street lamps, although it's distribution network has since grown to supply thousands of households with gas for cooking as well as industries who require gas as energy source. The Gas Works took advantage of the site's slope and as can be seen in Figure 5, the production of gas from coal followed a linear sequence from the coal drop-off point to the South-West downslope towards the No.1 & 2 gas storage tanks to the North-East. The Gasworks grew tremendously in its supply, from producing 3,9 million m³ in 1928 to a peak of 48 million m³ in 1948. After the early days of the Gas Works, this supply reached a peak until gas production started to decline in the period following the 1960s.

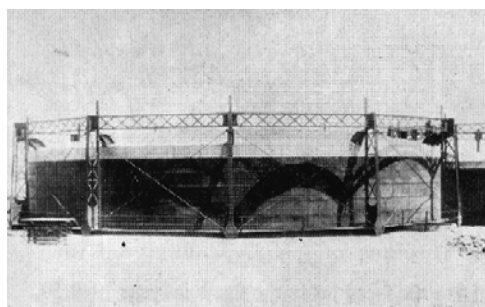


Figure 8 Gas storage tank at President street Gas Works (Tsica archive, 2017)



Figure 9 Purifiers at President street Gas Works (Tsica archive, 2017)

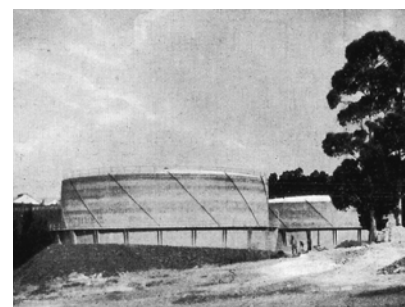


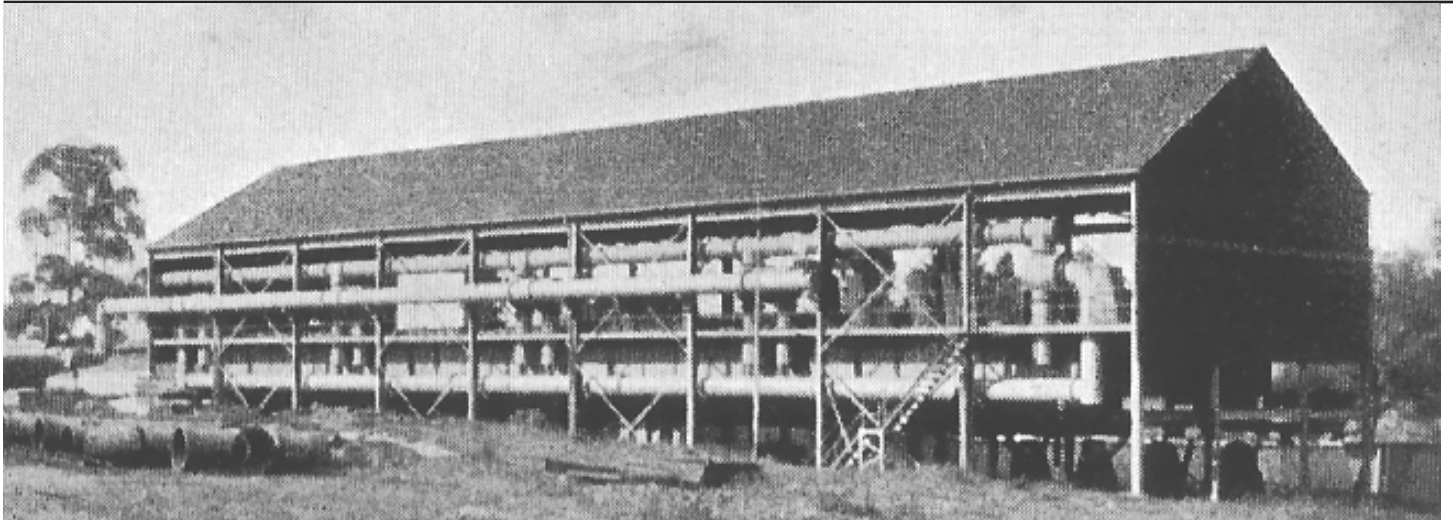
Figure 10 No.1 & 2 gas tanks at new Cottesloe site (Tsica archive, 2017)

Below: **Figure 11** Photograph of Purification plant, 1929 (Lauferts le Roux & Mavunganidze, 2016)

Bottom: **Figure 12** Aerial photograph of Gas Works site, 1960 (Lauferts le Roux & Mavunganidze, 2016)

Right: **Figure 13** Mr Therm, the mascot for Egoli Gas (Lauferts le Roux & Mavunganidze, 2016)

Far Right: **Figure 14** The liquid Ammonia collection area (Lauferts le Roux & Mavunganidze, 2016)





Meet Mr. Therm



2.3.2 Years of growth & eventual shutdown

The Johannesburg Gas Works was designed with expansion in mind and in the 1940s and 1950s the company built three more gas storage tanks to make its twelve-fold growth in supply since 1928 possible. Many more structures were built, including retort no 2 (which together with retort no. 1 form the two most iconic buildings on the site) as well as four more purification plants similar to the one shown in Figure 11.

In this period of growth, the Gas Works maintained a good public image through clever marketing by using a mascot (Figure 13) in all of its advertising material. The public could access the site to collect free liquid ammonia since ammonia was one of the by-products of the gas-making process and could be used as fertilizer. It seems that in spite of this interactive relationship with the public, concerns grew surrounding the pollution caused by the Gas Works. Yellow gas plumes could be seen billowing from the retort building chimneys occasionally and concerns also revolved around the condition of the Braamfontein Spruit, running underneath the tar distillation area within a stormwater drain. Although the concerns regarding the water pollution were unfounded (Tsica Heritage consultants, 2011:12) the end of gas production drew near for the Gas Works as natural gas began to be supplied from Mozambique via Sasol Secunda. The reasons for this transition was that the demand for gas had grown and secondly, the gas being supplied by Sasol was said to be of a higher quality.

Thirdly, the technology that was used on site was outdated by this time and it made more economic sense to buy gas from Sasol than to produce on site. In so doing, the existing distribution network could still be used to distribute gas to the city rather than produce on site. In the late 1980s the Gas Works was only producing 5% of the gas needed by consumers and in 1988, the decision was made to decommission the Gas Works as a gas producer.

The city leased its asset to a private company to run its operations but by 1992 the lease was terminated and the Gas Works officially shut down in July 1992. In 1993 the demolition of various structures on site commenced as the city sought to open space for other purposes. Perhaps the intention was that these new open areas could be leased out, similar to the two other existing leases on site. In 2003 the Gas Works site was sold to a company of which Egoli Gas owns 5% and it has since become profitable as gas pipes in Johannesburg are being re-laid to provide more households with natural gas. The current brand identity of Egoli Gas has actually placed the heritage buildings in a more stark contrast to the company's operations. Only the distribution plant and three remaining gas tanks are used currently but since the company can shift its location to another smaller location, the fate of the site and these structures in their post-industrial state remains to be seen.



2.3.3 The Gas Works and cooking

A little known aspect of the Gas Works heritage is its connection with cooking. The marketing mentioned above was aimed at popularizing gas as a preferred energy source for cooking and to market this to the public, the Gas Works had its own showroom containing various American and British gas stoves on sale. The showroom with stoves are still on display to this day and was used for decades for cooking demonstrations (Figure 15)

The Gas Works even compiled and sold a cook book containing recipes for meals that were ideally prepared on gas appliances. This was one of the few ways that the Gas Works maintained an interactive relationship with the public.



Left: **Figure 15** A cookery demonstration at the showroom at the Gas Works (Lauferts le Roux & Mavunganidze, 2016)

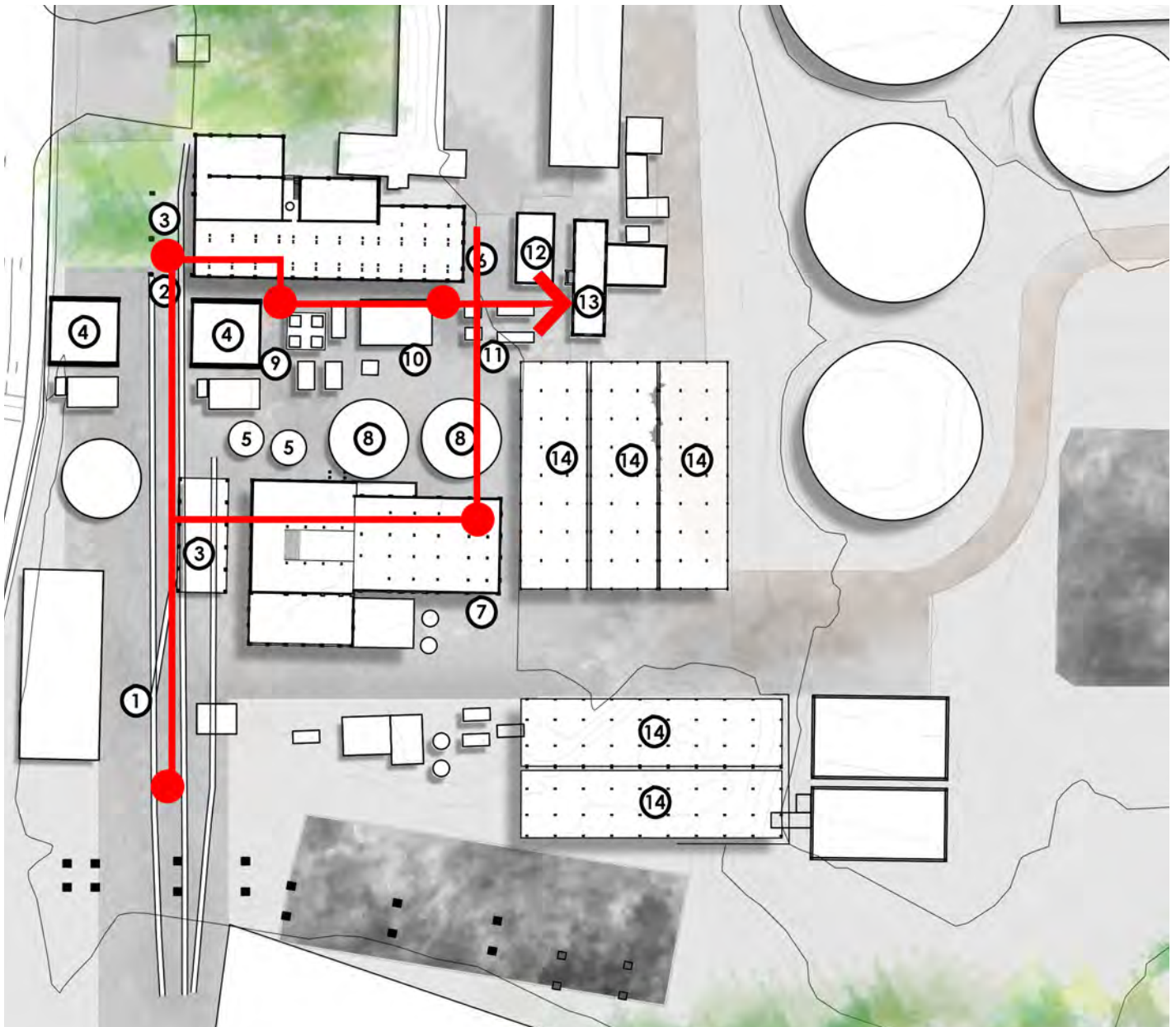
Bottom: **Figure 16** Gas stove cooking (iStock, 2017)

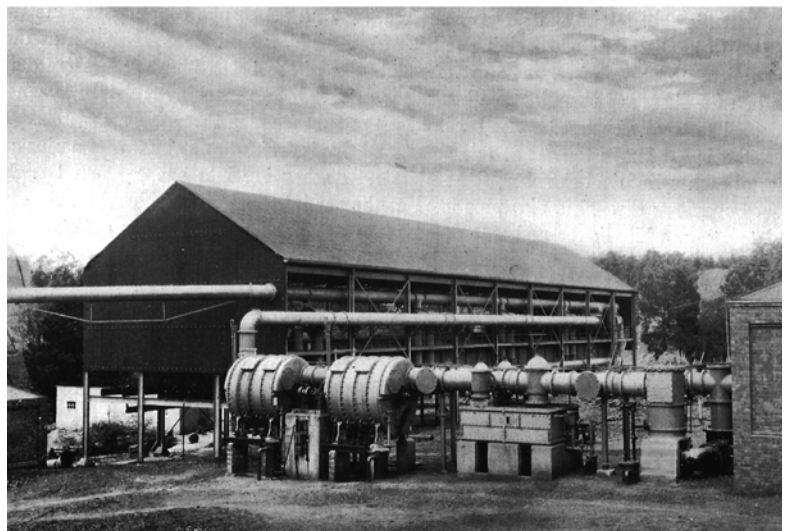
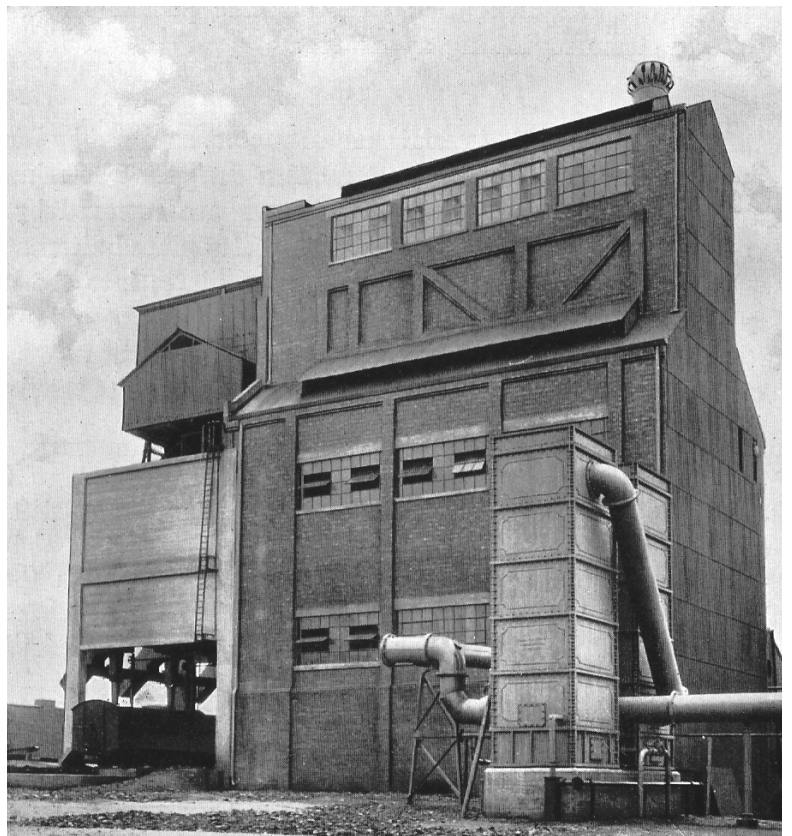
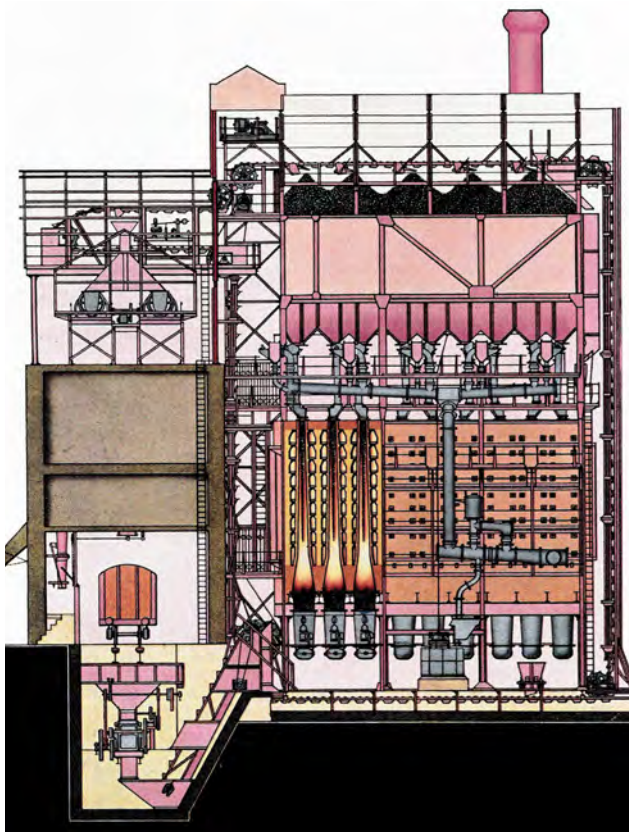
2.4 Gas production from coal

The process begins with coal being delivered by rail after which it is elevated by means of a conveyor system to the coal bunkers at the top of the Retort. As it gravitates down inside the Retort, it is heated until it breaks down chemically into a foul gas, tar and coke. The foul gas is partially cooled with water sprays, which causes the tar vapours to condense. The condensed water and tar then flow together towards the tar and liquor well. Upon leaving the Retort the gas passes through condensers, which cools it down to room temperature. During this cooling, condensate known as gas liquor separates and also flows towards the tar and liquor well.

The gas then passes through the exhausters which provides the necessary pressure differential to drive the gas towards the Gas Holders. On the delivery side of the exhausters the gas passes through an electrostatic detarrer that draws the remaining tar out of the gas by means of an electric charge of 30 000 volt.

The gas then passes through a series of washers, firstly the Livesey washers, then the rotary multi film washers. Here, a counter-current of water is brought into contact with the gas. Being soluble in water, the ammonia, present in the gas as an impurity, is removed.





Top Left: **Figure 17** Longitudinal section through Retort House 1 (Tsica archive, 2017)

Top Right: **Figure 18** Retort House 1 with condensers in foreground (Tsica archive, 2017)

Far Left: **Figure 19** Plan of structures involved in process and direction of energy flow (Author, 2017)

Left: **Figure 20** Condensers (item 9) in their current state (Photograph by author, 2017)

Right: **Figure 21** Livesey and rotary multifilm Washers (item 11) with purifier (item 14 on plan) shown in back ground (Tsica archive, 2017).

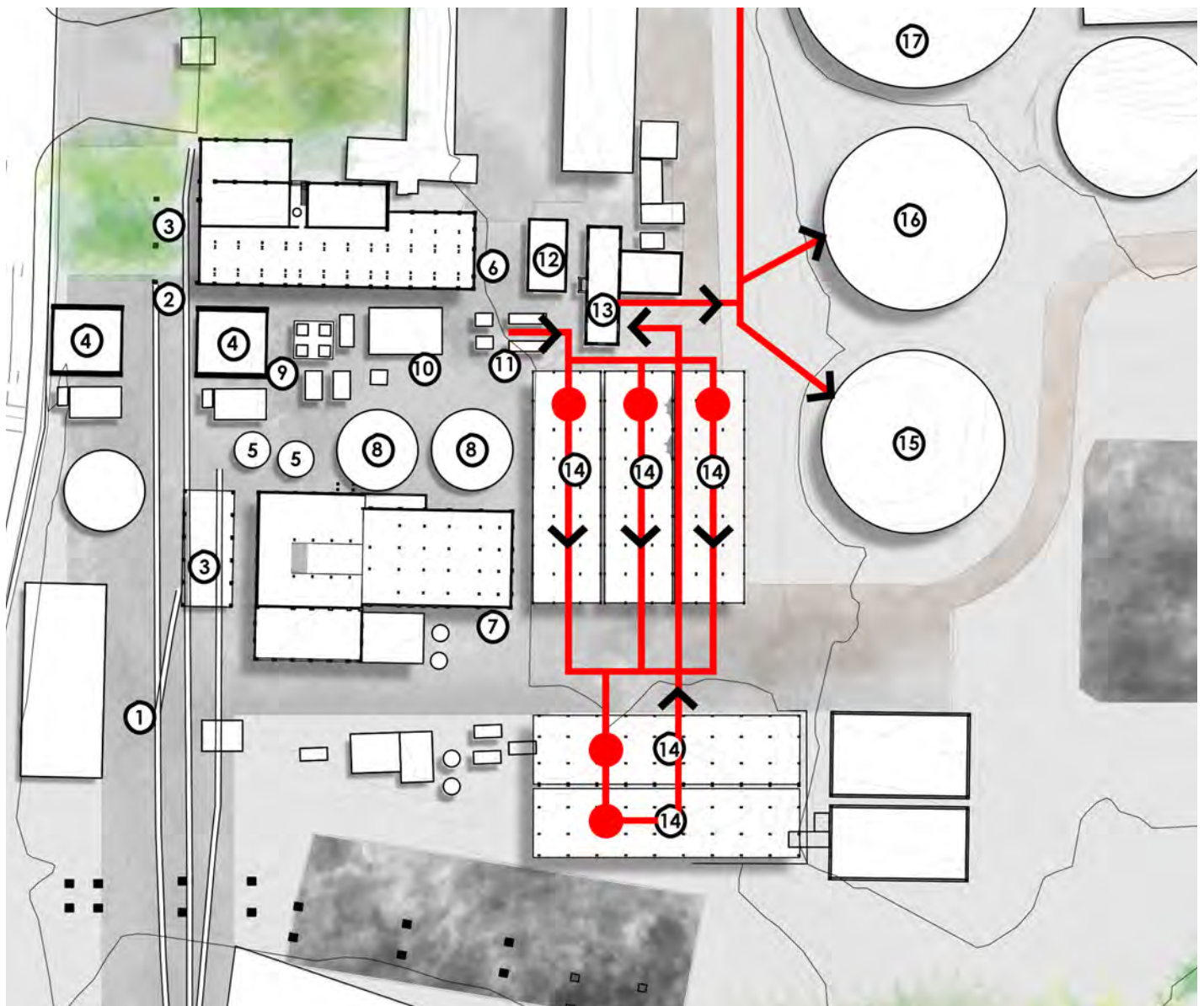
Plan legend of relevant structures

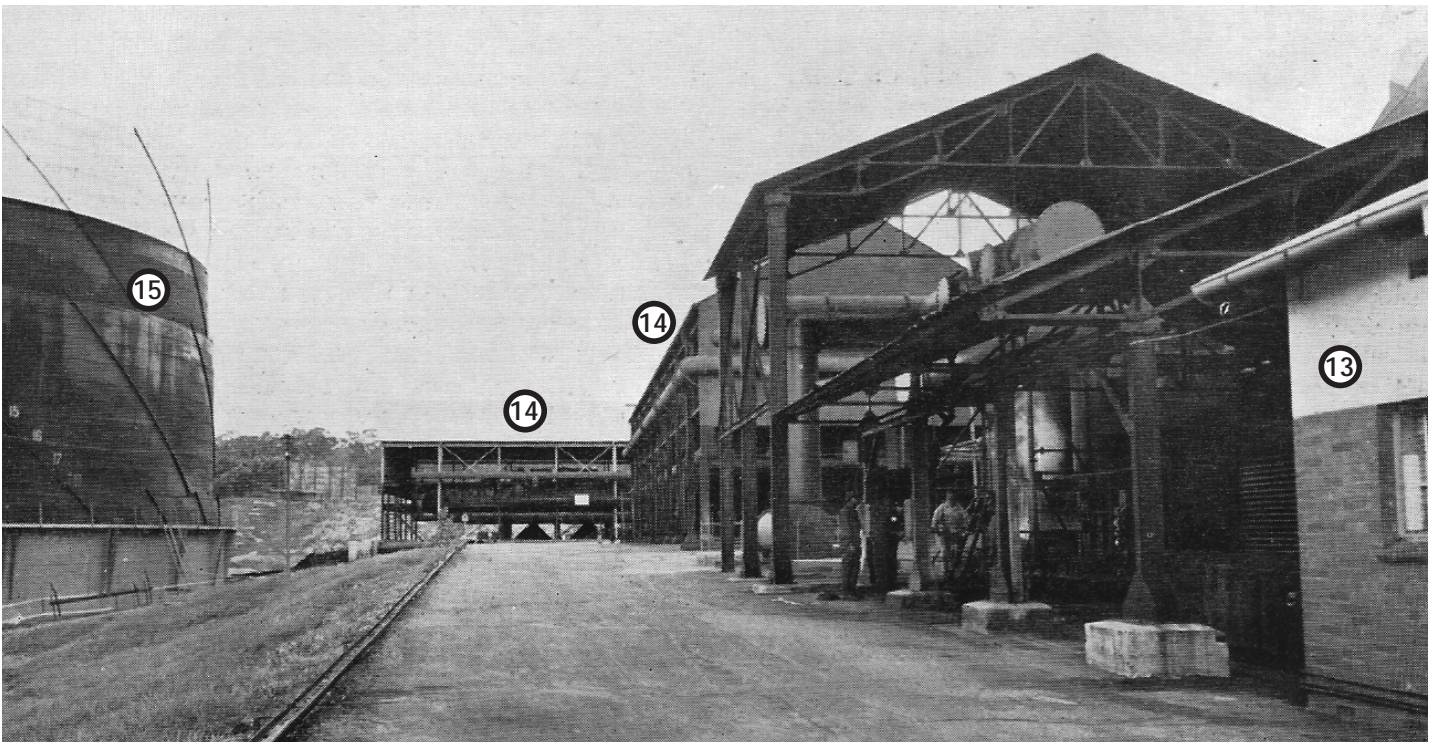
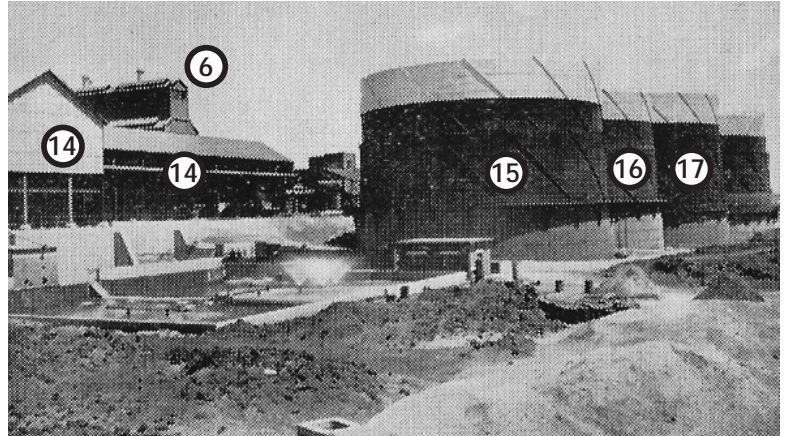
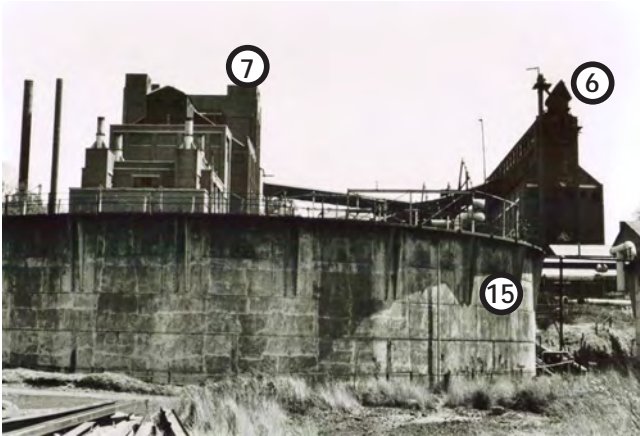
- 1) Railway line
- 2) Coal drop-off point
- 3)Coke bunker and coal bunker above
- 6) Retort House 1
- 9) Condensers
- 10) Exhausters and detarrer
- 11) Livesey and Multifilm Washers
- 14) Purification plants

After ammonia has been removed by the washers and has flowed as ammonia-laden water to the tar and liquor well, the only remaining major impurity in the gas is hydrogen sulphide. This was removed in the form of solid sulphur by mixing the gas with a small amount of air and passing it over an iron oxide catalyst supported on a suitable porous medium, such as wood shavings.

This process was facilitated within the Purification plants. After this the gas passes to the distribution plant or also known as the governor and meter house.

In here, gas flow is then measured by means of a station meter for accounting and record purposes and stored in the gas tanks. From the gas tanks the gas can follow two different paths. The first is via a governor to reduce the pressure to a value suitable for direct supply through a customer's meter into the customer's premises. The second is via the boosters into the high-pressure system, which carries the gas to strategic points throughout the city, where district governors allow the gas to flow at a lower pressure into the low-pressure distribution system.





Plan legend of relevant structures

- 11) Livesey and multifilm washers
- 13) Distribution plant
(meter and governor house)
- 14) Purification plants
- 15) Gas storage tank 1
- 16) Gas storage tank 2
- 17) Gas storage tank 3

Far Left: **Figure 22** Plan of structures involved in process and direction of energy flow (Author, 2017)

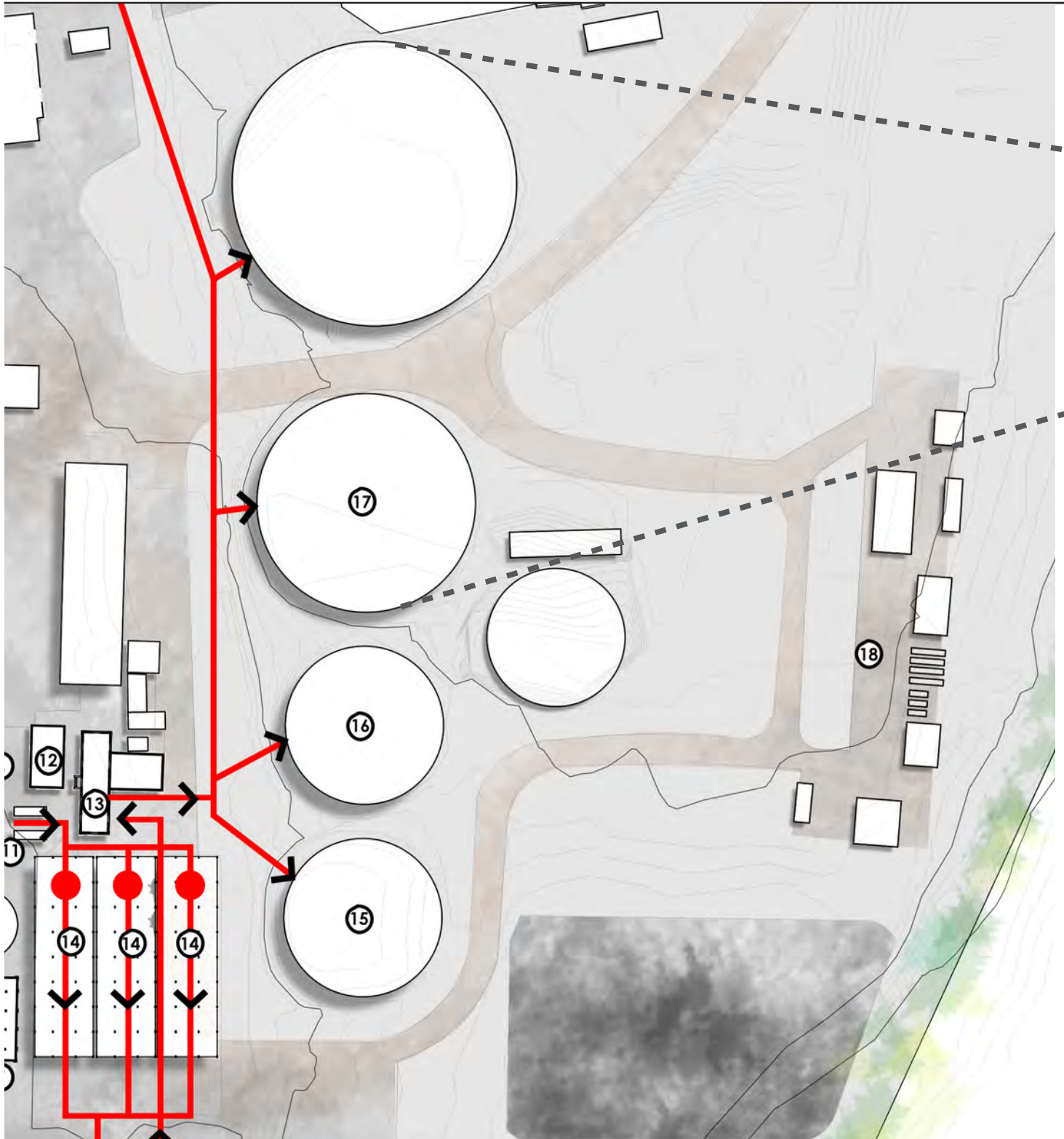
Top Left: **Figure 23** View towards Retort No 1 & 2 (Tsica archive, 2017)

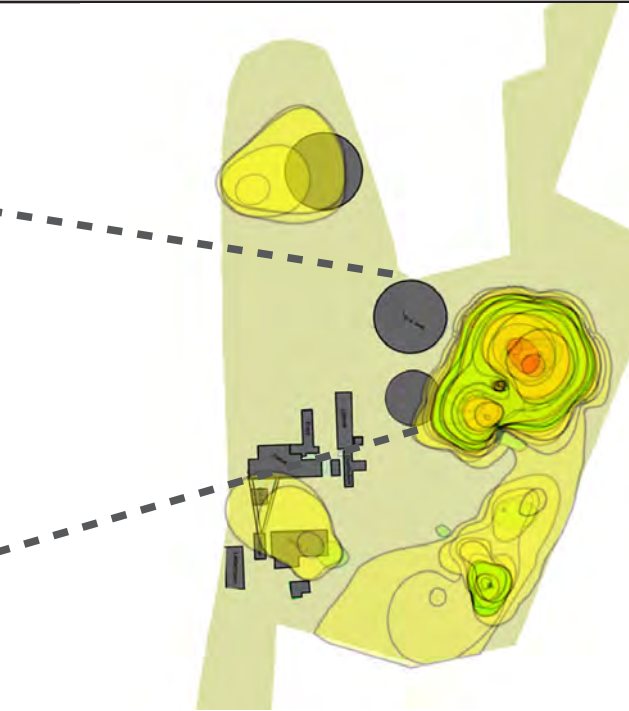
Top Right: **Figure 24** View of the No 1,2 and 3 gas storage tanks (Tsica archive, 2017)

Above: **Figure 25** View towards easternmost purification plants (Tsica archive, 2017)

Legend of relevant structures

- 11) Livesey and multifilm washers
- 13) Distribution plant (meter and governor house)
- 14) Purification plants
- 15) Gas storage tank 1
- 16) Gas storage tank 2
- 17) Gas storage tank 3
- 18) Tar distillation plant



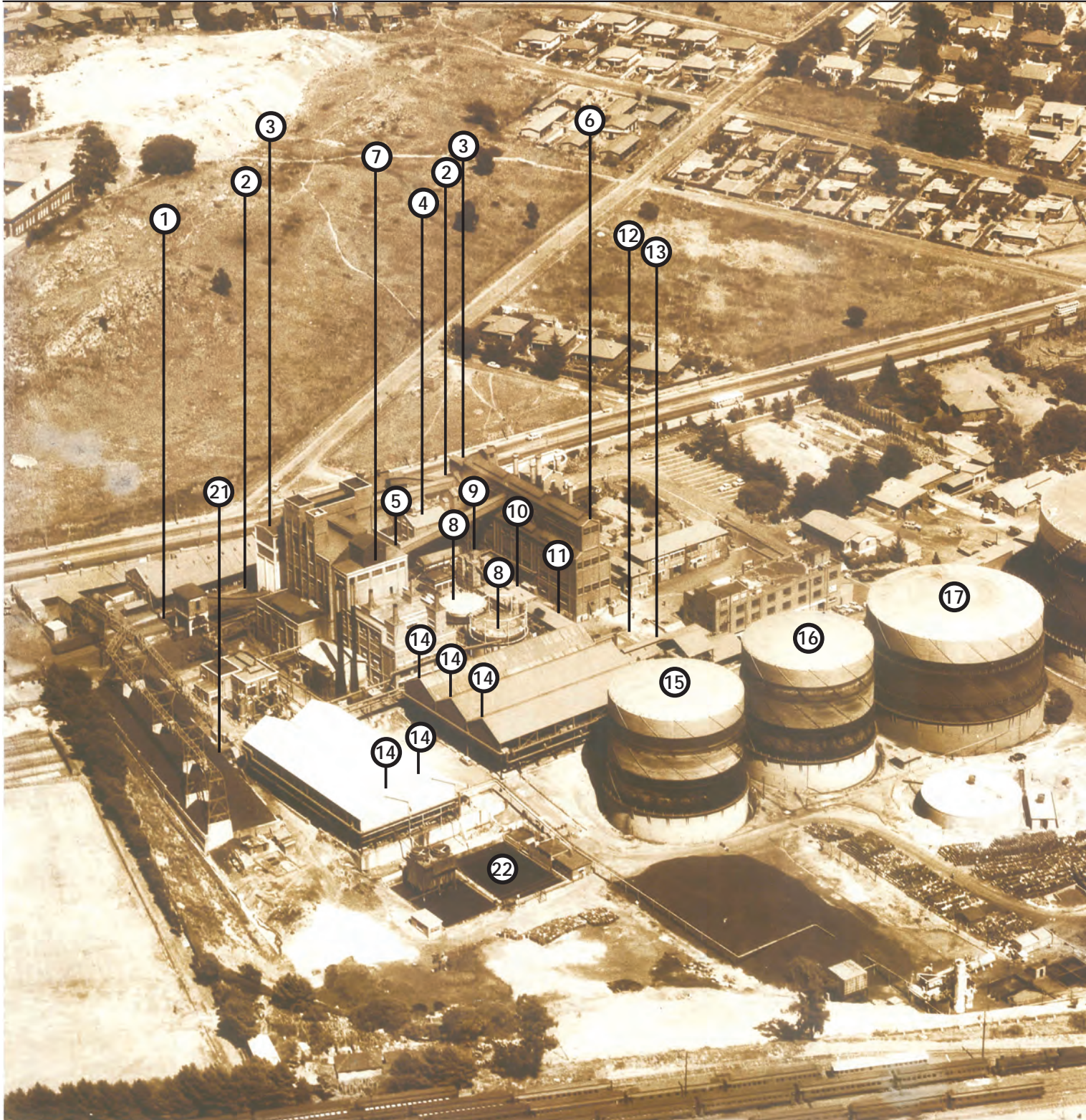


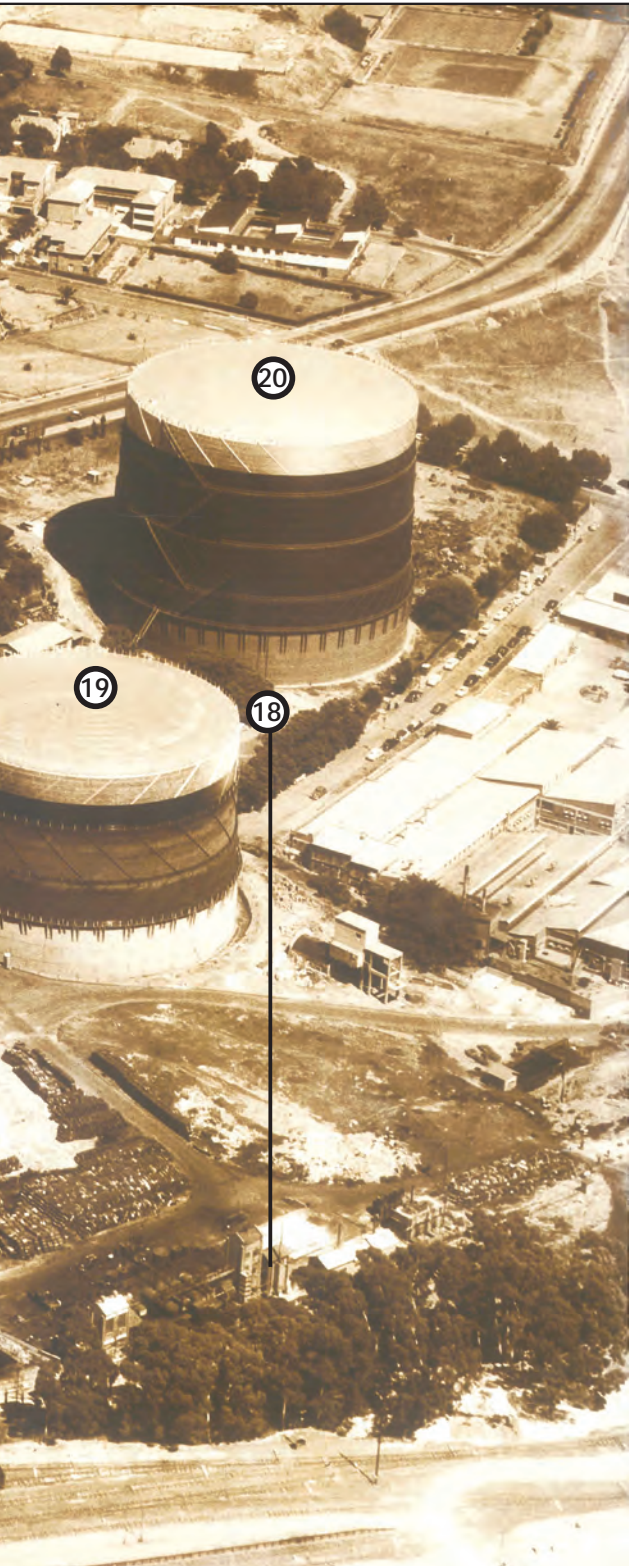
The Distillation plant

Since tar was one of the main by-products of this method of producing gas, it was required to build two tar distillation plants on the Eastern boundary of the site capable of handling 30 tons per day. The area of the site where tar was distilled has become severely polluted as a result of the soil's exposure to tar. The tar distillation plant has since been demolished but the layers of coke, tar, creosote and other hazardous materials are left as legacy and this area requires the most drastic remedial intervention of all the site.



Figure 28 Aerial of the gasworks site from the 1950's (Tsica archives, 2017) edited by author





Industrial structures

- 1) Railway line (demolished)
- 2) Coal drop-off point
- 3) Coke bunker and coal bunker above
- 4) Carburetted Water Gas plants
- 5) Small circular tanks (purpose unknown) (demolished)
- 6) Retort No. 1
- 7) Retort No. 2
- 8) Medium gas tanks (purpose unknown) (demolished)
- 9) Condensers
- 10) Exhausters and detarrer
- 11) Livesey and Multifilm Washers
- 12) Distribution plant additional building
- 13) Distribution plant (governor and meter house)
- 14) Purification plant (All five demolished)
- 15) Gas tank No.1 (demolished)
- 16) Gas tank No. 2 (demolished)
- 17) Gas tank No. 3 (operational)
- 18) Tar distillation plant (buildings demolished)
- 19) Gas tank No. 4 (operational)
- 20) Gas tank No. 5 (operational)
- 21) Weigh bridge
- 22) Cooling ponds (overgrown)

Figure 29 Aerial of the gasworks site (Tsica archives, 2017) edited by author

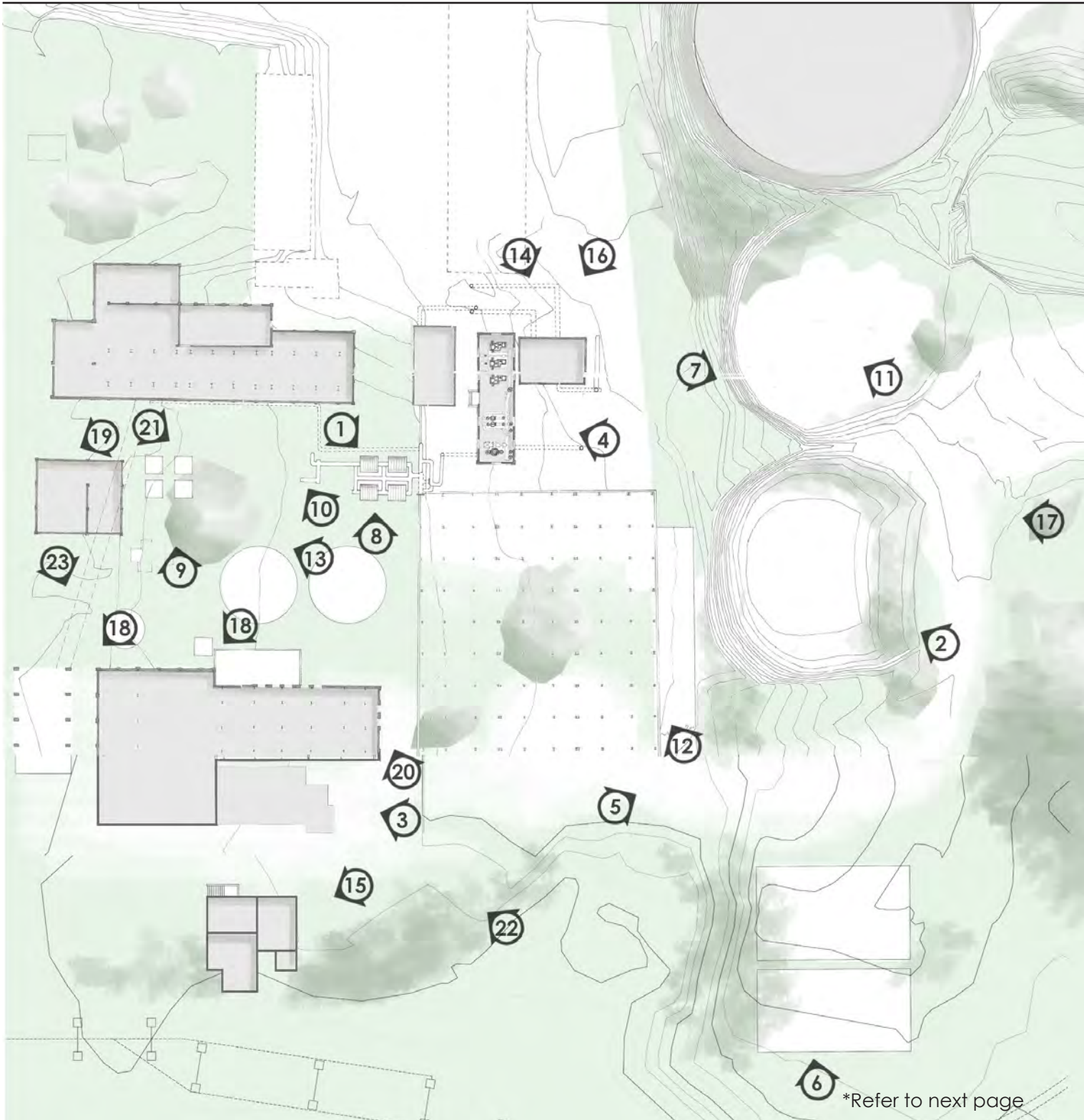
2.5 Present day zoning





At present there are three distinguishable landscapes observable on site of which the industrial core will be the particular site of investigation. From an early stage in the site research, it was decided that all four architectural interventions proposed for the Gas Works site will be located within the industrial core. The industrial core contains the most valuable heritage buildings on the site since it contained the essential industrial components for the production of gas. The auxiliary functions to the north were among others, the site managers house the labourers canteen. Although the reasons for focusing the schemes within the core are elaborated on in the urban vision description, this decision focused the site research to this particular zone

2.6 Present day condition of industrial core





1



2



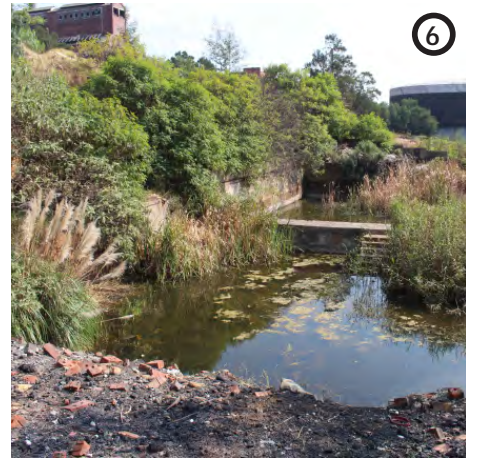
3



4



5



6



7



8



9



10



11



12



2.7 Unpacking the immediate site (the identification of order and place)

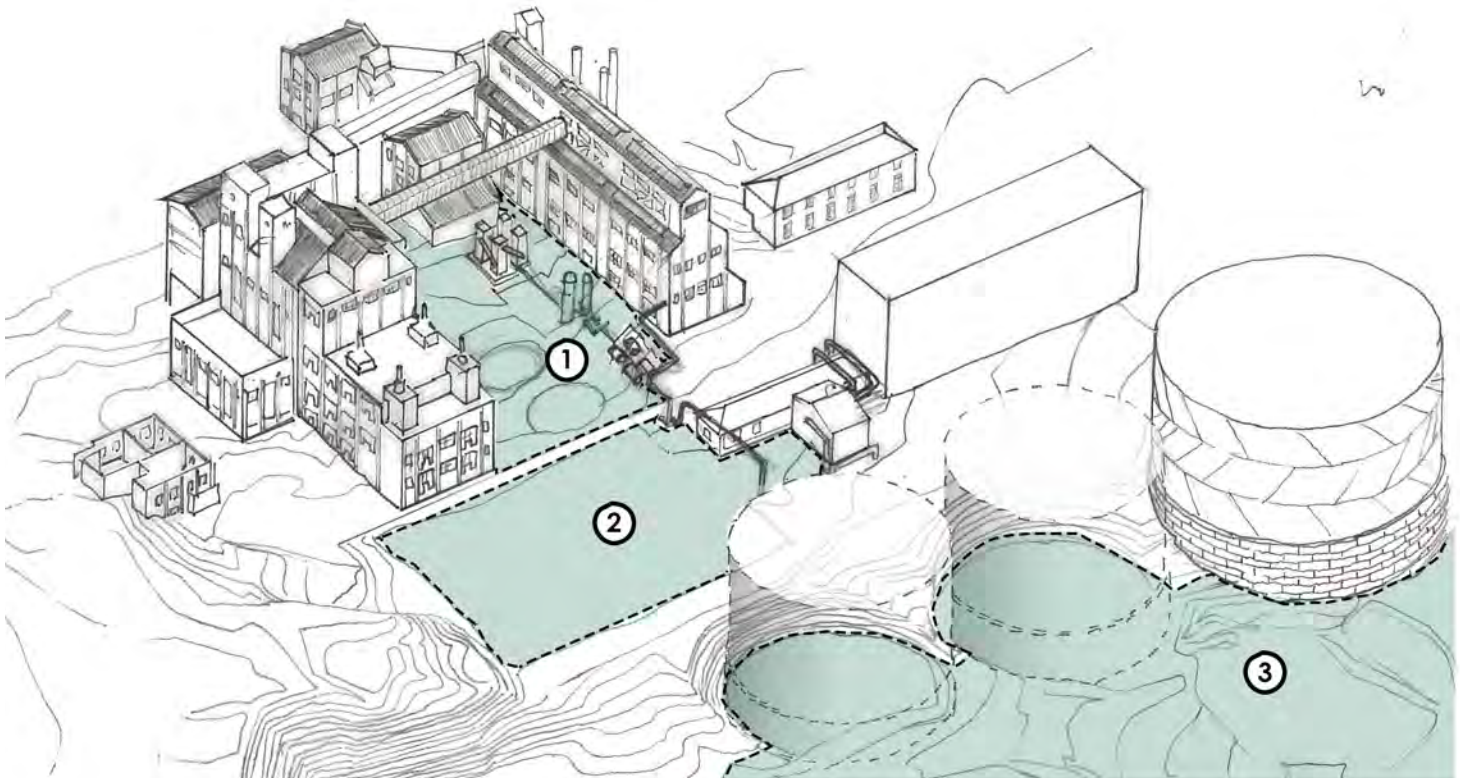


Figure 30 Identifying zones and place (Author, 2017)

2.7.1 Identifying zones and place

Within the central zone of the site or the “nucleus” of industrial activity, the topography has been altered to create three zones. These zones can be identified by their roles in the production of gas from coal and are:

- 1) Production from raw materials,
- 2) Purification from impurities and distribution and
- 3) Reception and storage.

It is important to note that understanding each zone or place within the Gas Works site depends upon understanding it in relation to other zones. This is especially the case in zone three, where the large circular holes and severe soil pollution can only be understood as the result of the activities occurring up-slope in zones one and two. Maintaining an understanding of the nature of these zones should guide any new architectural or landscape interventions if the uniqueness of place is to be maintained.

Figure 31 Zones of industry, sequence of industry and demolished structures. (Author,2017)

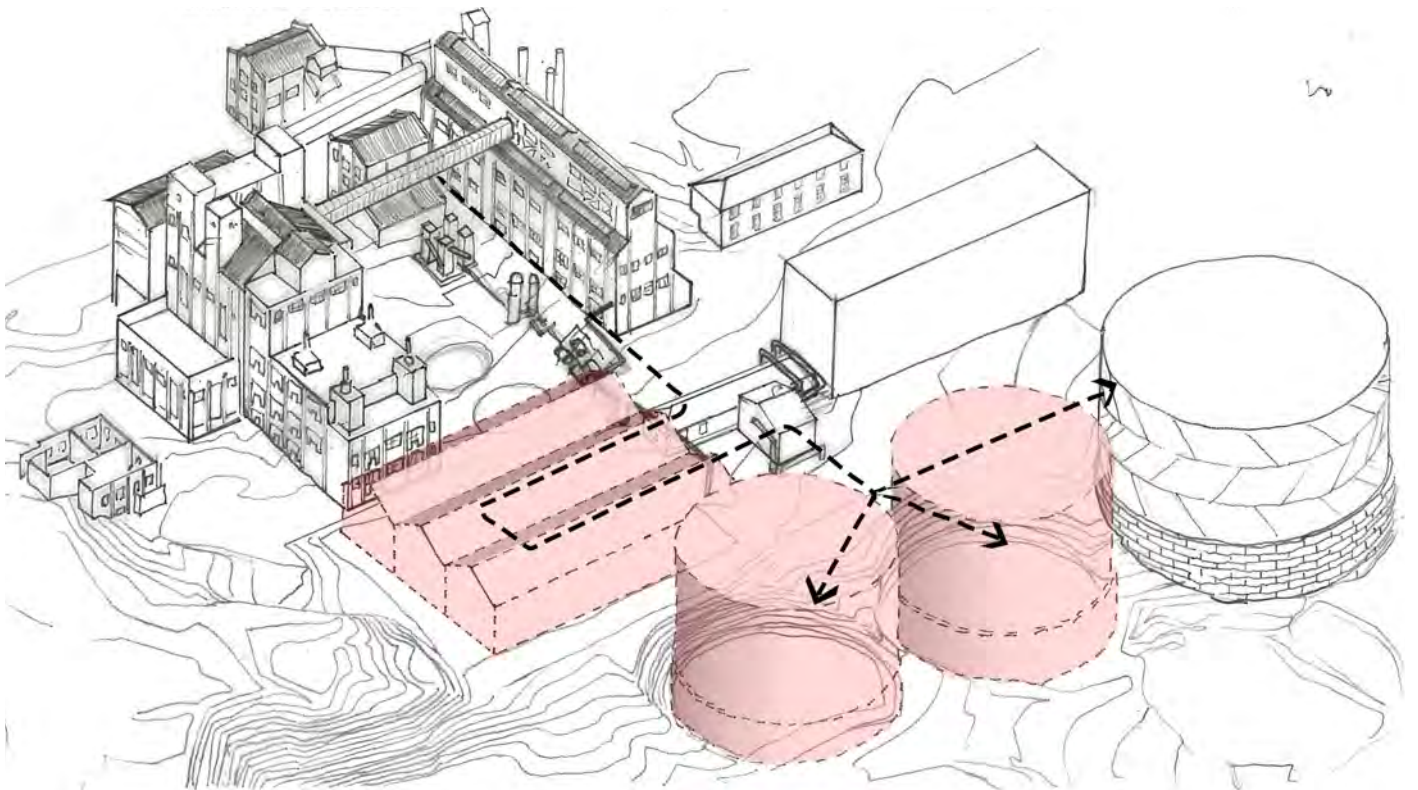
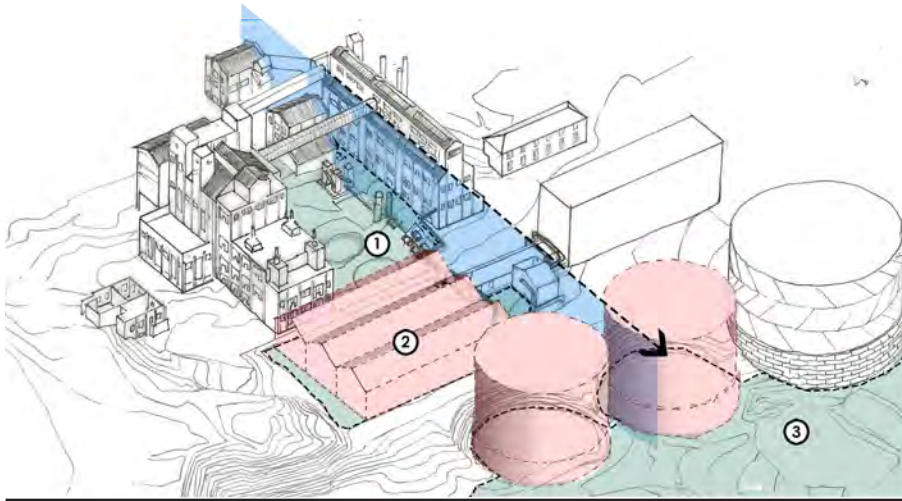


Figure 32 Demolished structures and their role within the sequence of the industrial process (Author, 2017)

2.7.2 Broken coherence

The five structures shown highlighted above, the three purification plants and the No 1 and 2 gas tanks, are the five significant structures of which there are still legible remains. Their presence signifies the last two steps of the coal to gas process. All that remains of the purification plants are the foundations and stub columns that protrude from the ground. The uniqueness of the Johannesburg Gas Works site as an industrial artifact is that it has the quality of a living museum, where the process of gas production follows a legible, linear sequence towards the North-East. Therefore, remaining conscious of the presence of these structures will ensure that the heritage and story behind the gasworks will remain legible on the site.

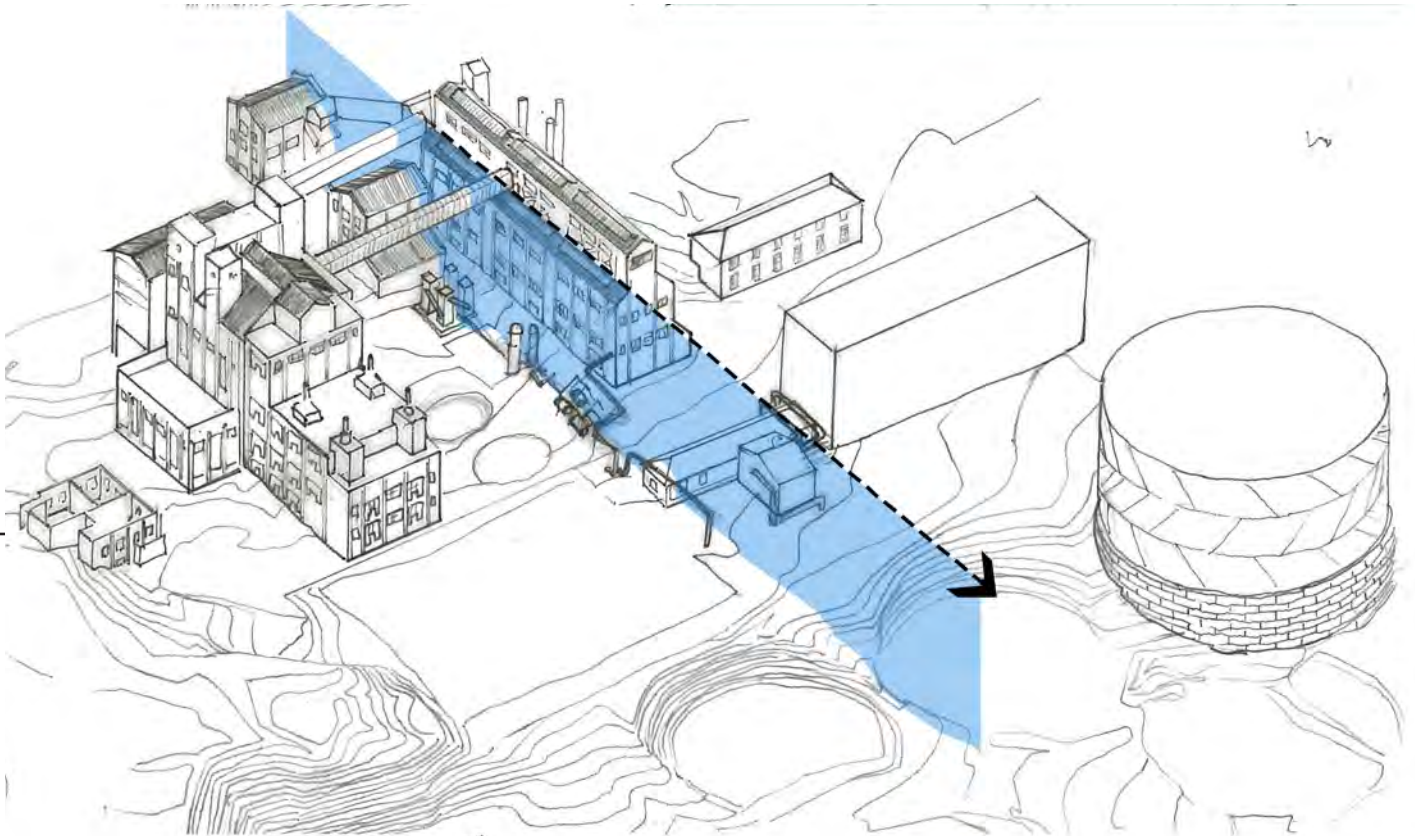


Figure 33 The linear sequence of the original coal to gas process (Author , 2017)

Figure 34 View towards Retort 1 through No 1&2 gas tanks (Tsica archives, 2017)

2.7.3 The Spatial logic of Industry

The blue line across the terrain illustrated in Figure 33 indicates the location of Retort No 1, the condensers, the exhausters and detarrer, the Livesey and Multifilm Washers, the distribution plant and the first two gas tanks. This linear arrangement was the original layout in 1928 whilst retort No 2 and the three other gas storage tanks were built from the 1950s onward. Therefore, this line of movement entails the most informative experience with regard to the Gas Works heritage.

The sequence followed the fall of the topography in order to assist in the flow of industrial fluids and gas. In that sense, the industrial process has a close relationship to the landscape since it arranges and stretches itself according to the site. Since gas tanks No 1&2 were the final destination of the gas produced, the line ends in between the two tanks and this was also a line of movement for staff working on the site as can be seen in Figure 34.



Figure 35 The urban context in contrast (Author, 2017)

2.8 Understanding the urban condition



Reading the story of the Gasworks as an isolated entity is important in as much that it contributes to our understanding of its uniqueness. However, the uniqueness and heritage value is put under pressure when one understands the context in which the Gasworks finds itself today, almost 90 years after its inception. One can easily surmise an initial identity and value from the aforementioned historical account as follows: The Gasworks was a major contributor to industry in the mining camps; it was intended to be inconspicuous in its urban environment; the public was engaged through its fertilizer provision and cooking demonstrations and it is the only remaining example of a coal to gas plant in South Africa.

The threat of insensitive development lies in the demand and tempo of development of its current context. Initially intended to be on the outskirts of the city, the Gasworks has become surrounded by a dense and rapidly growing Braamfontein. The site has the University of the Witwatersrand to the East and the Bunting Road campus of the University of Johannesburg to the West and together with the John Orr Secondary school and the collection of restaurants and artisan shops in the 44 Stanley compound to the North, the 14 hectare site is surrounded with daily, buzzing activity. One can see why this site would be best developed as a dense urban development, however there are two lenses through which the contextual influences and demands can be seen, each lens suggesting a different approach. After these two issues have been understood, it will be apparent why an understanding of appropriate theories on developing post-industrial sites in urban areas is necessary. Since this section of the dissertation deals with the contention regarding developing post-industrial sites and the seemingly opposing demands of

development and heritage conservation, the site will be viewed through two lenses: context as a threatening informant to heritage and context as a protective informant of heritage.

Context as threatening informant to heritage

The Johannesburg Spatial Development Framework (SDF) is a well-intentioned document of Johannesburg's future development, however when the Egoli Gasworks site is considered in relation to the Johannesburg SDF, it is evident why dense development of the Gasworks site would seem appropriate. The site is located a mere 500 meters south of the Empire-Perth arterial, which is a significant route within the Corridors of Freedom strategy that seeks to "reap the full benefits of transit investments" (City of Johannesburg 2016:57) by increasing the urban intensity (job, residential and built density) along this route. Spatial inequality in Johannesburg or the vast distances between residential areas and job opportunities is addressed in the Johannesburg SDF : "providing housing for low-income households that is well located regarding public transport, hard and soft services and jobs, is imperative" (City of Johannesburg 2016:45).

The motivation behind proposing a dense, mixed use development for a site so close to both the Johannesburg Metro station 1km to the South and significant road connections to the North, certainly could solve some of the various problems that Johannesburg currently faces such as "urban sprawl and limiting densities; high levels of spatial inequality and a mismatch between jobs and housing" (City of Johannesburg 2016:49) Johannesburg's population is still growing at a rate of about 2% per annum, albeit that the rate is decelerating.

The city model that is supported by the SDF to address the sustainability of a growing Johannesburg is the polycentric city which is defined as "clustering of population and jobs with polycentricity at two scales: compact polycentricity in a limited hyper-core

(transformation areas), and metropolitan polycentricity with compact and mixed use satellite 'cores...' (City of Johannesburg 2016:66) In a practical sense this would increase residential density near the city and transit nodes and also bring job density to high density residential areas such as Soweto.

When one considers that the size of the Johannesburg Gas Works site is the same as 18 inner city blocks, it is evident why the provision of housing along with mixed use buildings would seem to outweigh any ecological or heritage concerns. Other demands that stem from differing points of departure will challenge the needs laid out in this paragraph - that being the need for ecological green space in dense urban fabrics and the significance of the heritage of the Gas Works. Can density be reconciled with these two demands? In cases where heritage structures are significant insofar as their facades can be retained, residential density can easily be accomplished without compromising their value.

But in a site such as the Johannesburg Gas Works where industrial artifacts, the interior spaces of the two large red-brick Retort buildings as well as spaces of narrative that are essential to understanding the story behind the site's industrial period inhibit dense retrofitting; are these demands then mutually exclusive or is mid-way compromise of all three demands (public space, heritage and density) possible?

Context as protective informant to heritage

The rapid expansion and high urbanization rate of Johannesburg have placed such developmental pressures on open spaces that the city has inherited a fragmented open space system that fails to provide the benefits and potentials of a Metropolitan Open Space System (MOSS) (Strategic Environmental Focus, 2002:2). In order to be a successful MOSS that contributes to biodiversity, ecological systems and the recreational needs of citizens (all of which affect quality of life) the city of Johannesburg needs its ecological open space to be 33% of the city's 164 458 Ha area. Currently it is a mere 18% (Strategic Environmental Focus 2002:37).

The site has a specific environmental value, being located in a basin that facilitates the flow of the Braamfontein Spruit although it is currently channeled below the ground surface in a storm-water channel. Being of such value the site should be appreciated for the environmental services that it can provide. Fortunately, this value is also mentioned in the Johannesburg SDF. These ecosystem services are provisioning services, regulating services, cultural services and supporting services. In the case of the Gas Works site, the most crucial benefits that can be unlocked lie in the cultural services that can be provided by it as an open green space. Cultural services can be defined as follows "cultural services are the benefits people obtain from ecosystems such as reflection, recreation, inspiration, and aesthetic enjoyment, and include cultural diversity and educational values" (City of Johannesburg 2016:61). When one considers the large concentration in population surrounding the site from two tertiary educational institutions and one secondary educational institution, the potential for using the site with such rich heritage for

educational purposes as mentioned under cultural services is immense. Not only this, but the potential of integration and mingling of students, working professionals and the public is not as easily realized in a less prime site. Furthermore, the site's specific post-industrial condition supports the transformation of the site into a park typology since soil pollution caused by tar distillation on site necessitates remedial actions such as phytoremediation and soil capping. The site's soil would have to be fully ameliorated before dense development could even be considered.

On a larger scale, it is important to consider the effects of climate change on African cities. As the sub-region is warming, the following issues are important for all African cities to avoid: "unguided urbanization, degradation of freshwater resources, lowered levels of food security and failure of climate change adaptation strategies..." (City of Johannesburg 2016:34). Considering the pervasive drought that South Africa is still recovering from in 2017 as well as the danger pertaining to freshwater resources and food security in densely populated cities, exploring the potential of the Gasworks site to be innovative in terms of water and food security can inform the nature of any intervention on the Gasworks site.

When the site is also seen within the family of open green spaces in Johannesburg, with the Peter Roos Park 2,2 km to the East and the Kingston Forest Park 1,8km to the West, the site's potential as an essential contributor to the JMOSS can be seen. Maintaining the site or rather significant portions of it as open green space also poses no threat to reading and appreciating the rich industrial heritage since privatization and land development could be controlled more vigorously.

2.9 Responding to the urban condition

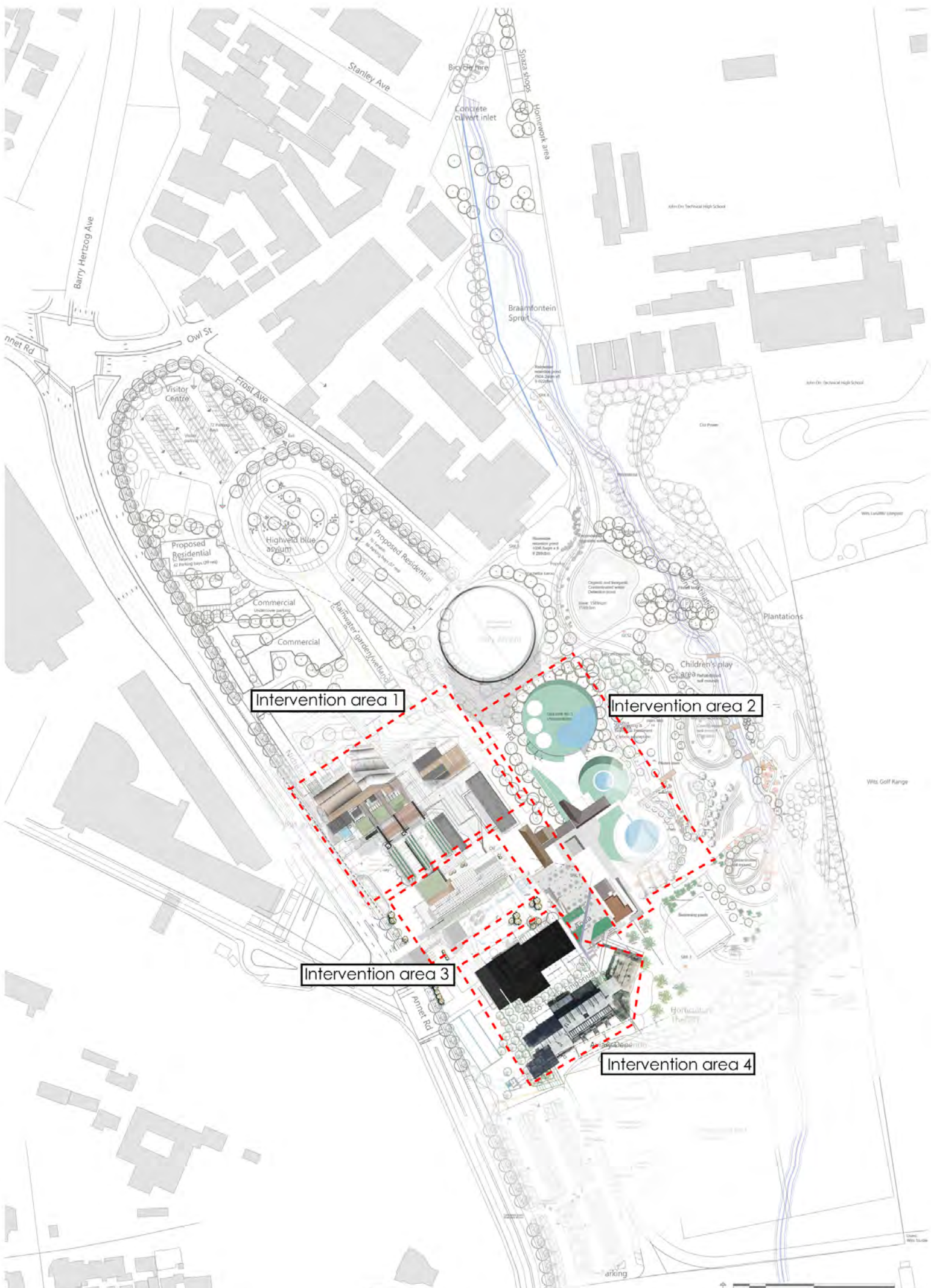
Restitution Park - An Urban Vision

For the Gasworks site, an urban vision or precinct plan was required that could balance the various demands on the site whilst prioritizing the industrial legacy of the Gasworks. The urban vision stemmed from addressing various relationships that were in need of restitution. It was essential to re-establish the relationships between the public and the site (via accessibility); the heritage of industry to the public (via educational heritage commemoration), ecology to industry (via ecologically sensitive buildings of production) as well as the city to the site (via appropriate responses to the urban and cultural setting of the city).

Spatially, this urban vision can be implemented by proposing a dense mixed-use development for about a quarter of the site's area to the North-West. This development will include residential, commercial as well as a business incubator focused on entrepreneurial start-up businesses. The motivation for this is to steer away from large corporate identities on the site but rather to establish the site-informed notion of innovation and technology that could easily partner with the two adjacent universities. For the most sensitive heritage zone within the site, the two red brick retort buildings and their immediate surrounds, a nucleus of buildings that showcases ecologically sensitive industries is proposed, together establishing a central public heritage square as the foyer to the site. These proposed activities are textile, aquaculture and aromatic plant industries that contribute their public components to the central square. Towards the east a public park that highlights the remedial actions involved in tar polluted soil is proposed and occupies half of the total site area. By establishing these three precincts within the site the three priorities that address the site's potential

is represented- ecology, the heritage of industry and the city. In order to implement the conceptual aims of restitution, the presence of water as well as recreational exploratory routes (such as cycle trails and sky bridges) are juxtaposed over the pragmatic circulation requirements of the site. With regard to formulating a heritage approach to the site's various heritage buildings, an analysis was done on the significance of each building on site with the help of Monika Lauferts Le Roux, author of *the Johannesburg Gas Works*.

It was found that apart from the two red-brick retort buildings and the three gas tanks, buildings could be altered or removed to the discretion of the design team. The heritage assessment concluded that the Gas Works showcased and still showcases the innovative process of producing gas from coal. This was a major point of pride for the 1920s South Africa and the Gasworks has been the provider of an essential service from 1928, although the means towards that service has left the site itself damaged. Therefore the heritage fabric should be handled with respect and the architecture proposed for the heritage square should seek to respond to the heritage fabric. In order to preserve the clear narrative of the site's history, alterations to the large retort buildings will be minimal and interior focused. The industrial artefacts standing in various locations on the site will be preserved and form part of the objects within the square and park. This dissertation gradually adjusts its focus towards a specific intervention within the heritage square and in addressing this particular site, an understanding is necessary of its unique condition. After understanding its condition, the appropriate theories will come to the fore in how to approach such a site.

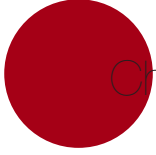


Intervention area 1

Intervention area 2

Intervention area 3

Intervention area 4



Chapter 3

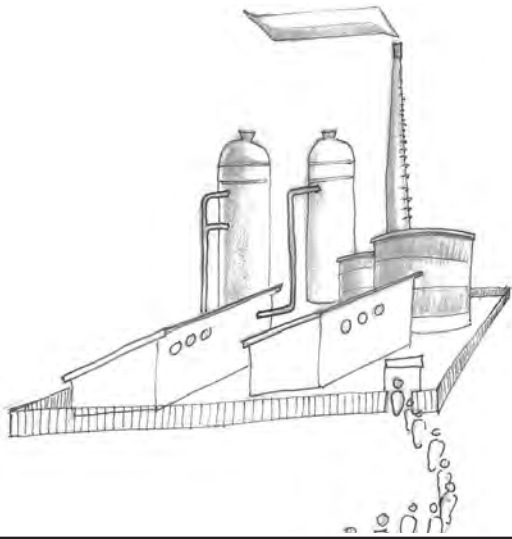
Appropriate theoretical framework

Introduction

Post-Industrial landscapes are unique heritage assets that speak volumes of the time in which they were initiated. Since many of these sites globally have been decommissioned, they have since undergone deterioration or, more dramatically, demolition. Often, the extent to which any intervention can be done on these sites depend upon the extent that remedial action of the natural resources is required. However, remedial action and more extensive intervention such as re-purposing of existing structures can be done in a way that negates the uniqueness of the terrain. These sites, and the Johannesburg Gas Works site were unique indeed. These sites of manufacture that were once alive with noises, smells, fumes and labour are now frozen in time and often possess the ephemera of austerity and mystery. Therefore particular theoretical stances have to be explored that recognize this intangible uniqueness. Two theories that deal with the intangible aspects of the site cover the aesthetic behind austere artifacts and the inherent "personality" that these sites seem to possess. The theory that the site can be read as a series of sequential layers will grapple with the existence of post-industrial sites as base layers upon which new interventions are to be scripted as new layers that create a purposeful juxtaposition with the existing base layer. And lastly, as a theoretical reference, appropriate charters and approaches to the commemoration and reconstruction of structures will be discussed in order to arrive at a clear point of departure for any new intervention at the Johannesburg Gas Works site.

The theoretical approaches that are to be discussed in this chapter are as follows:

- 1) The International Council for the Commemoration of Industrial Heritage (TICCIH) guide to industrial heritage conservation as well as the Nizhny Tagil charter for Industrial heritage.
- 2) Japanese Wabi-Sabi aesthetic.
- 3) Reconstruction and commemoration.
- 4) the "Genius Loci" of place.
- 5) Reading the site as a palimpsest.

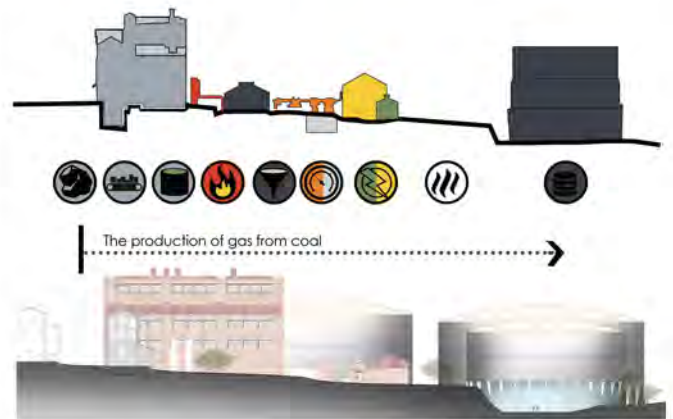


TICCIH

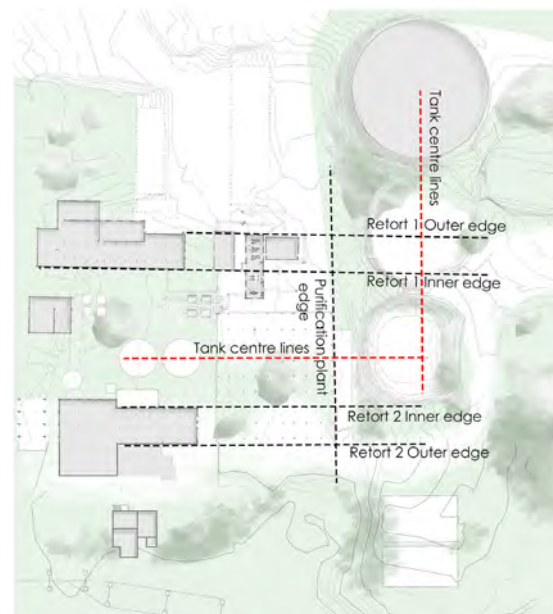
The TICCIH has put together a useful guide in approaching industrial heritage in their book *Industrial Heritage Re-tooled* as well as the Nizhny Tagil charter for industrial heritage. The Nizhny Tagil charter summarizes the value of industrial heritage firstly as “evidence of activities which had and continue to have profound historical consequences” and the global significance of this evidence; secondly as something of social importance and how it provides a sense of identity to a community; thirdly, that the value is intrinsic to the site itself and lastly, value lies in the rarity attributed to pioneering or innovative technologies of the era (ICOMOS 2003). The charter also states under its guidelines on conservation and maintenance that a thorough understanding of the various processes on site should guide the nature of any conservation work or interventions. The charter discourages exact reconstruction and views it as an exceptional intervention which is only appropriate if it benefits “the integrity of the whole site, or in the case of the destruction of a major site by violence.” (ICOMOS 2003). The charter also encourages the education of industrial heritage in educational institutions. This didactic potential could also be realized much more with in-situ visits.

Unique elements:

1) Relationship between process and the landscape.

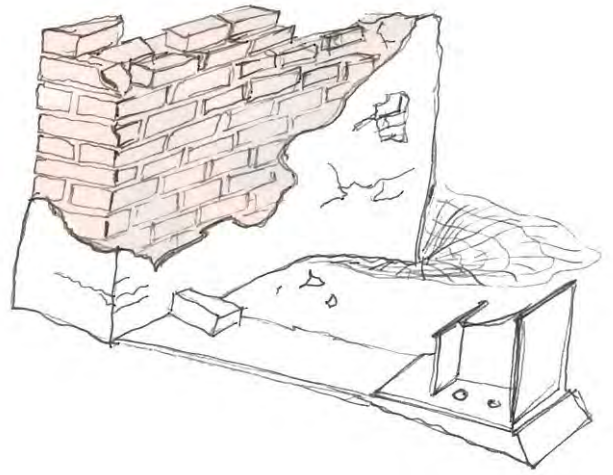


2) Spatial ordering system



Below left: **Figure 37** Noteworthy heritage aspects of the Gasworks site (Author, 2017)

Below right: **Figure 38** Wabi-Sabi application on the Gasworks site (Author, 2017)

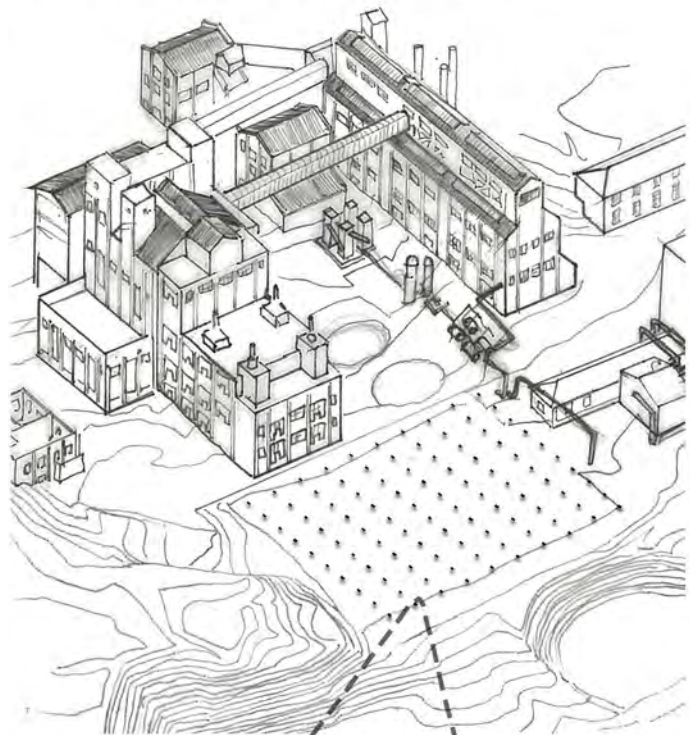


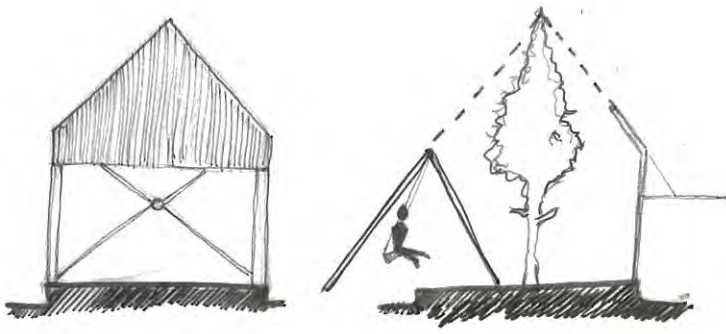
Wabi-Sabi aesthetic

Masaaki Okada in his article in *Industrial Heritage Re-tooled* titled *Industrial ruins* speaks of two explanations behind the appreciation of the aesthetics of ruin. He derives an understanding of this appreciation from the 18th century English Picturesque gardens in which the superficial value of the placement of ruins within these gardens spoke of a connection between the garden landscape and nature since natural processes caused the current state of decay of the ruin (Okada 2014:153). They possess the elegance of ephemera, recalling the notion of the passage of time and decay. He also mentions the Japanese concept of “Wabi-Sabi” which speaks of the tranquillity and higher beauty seen in the austere, incomplete or the absence of apparent beauty. The appreciation of the post-industrial landscape was brought to the surface in the essay by Robert Smithson in 1967 *A Tour of the Monuments of Passaic, New Jersey* although the first industrial to park typology had occurred in the 1860s in the Parc des Buttes-Chaumont by J.C. Alphand (MOMA 2008:25)

Industrial remnants:

The foundations of the purification plants.





Reconstruction and commemoration

In a recent article by Professor Piet Vosloo from the University of Pretoria on the conservation of the Tswaing salt works in Gauteng, the words of J Hunt are quoted to strengthen the importance of capturing a site's identity and telling its story to the public, whether the strategies employed are conservation, restoration, alteration or re-use, "If the designer draws out, reaffirms the meaning of a site – whether that theme or narrative is ideological or geomorphological, general or site-specific – he celebrates a site's identity." (Hunt cited in Vosloo 2015:47), and in quoting Treib, "Humans imbue landscape with memory using several vehicles... The most direct action maintains the historical form of the land: preservation...a second means of commemoration retains the noteworthy elements of the original landscape, ... perhaps a building typology..." (Treib cited in Vosloo 2015:47)

In agreement with the Nizhny Tagil charter, Scott emphasizes that any demolished work should not be reconstructed without a thorough interrogation and he maintains that the purpose of alteration is that of translation, "to translate a building into the present, in so doing making it suit a modern way of life". (Scott cited in Vosloo 2015:44)

In approaching the commemoration of demolished industrial buildings, a strategy would have to be informed by a thorough questioning of the original structure and the altered form after translation into appropriate materials, function and scale have been applied. How would the translated form pay homage to the earlier form, yet be distinguishable as a new creation? A further understanding on the subtleties of commemoration is required

Industrial remnants:

Demolished buildings and their building typologies

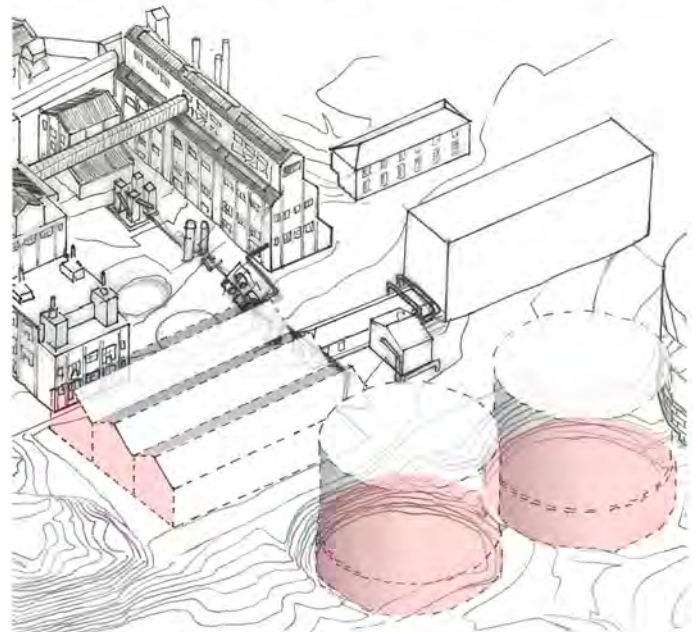
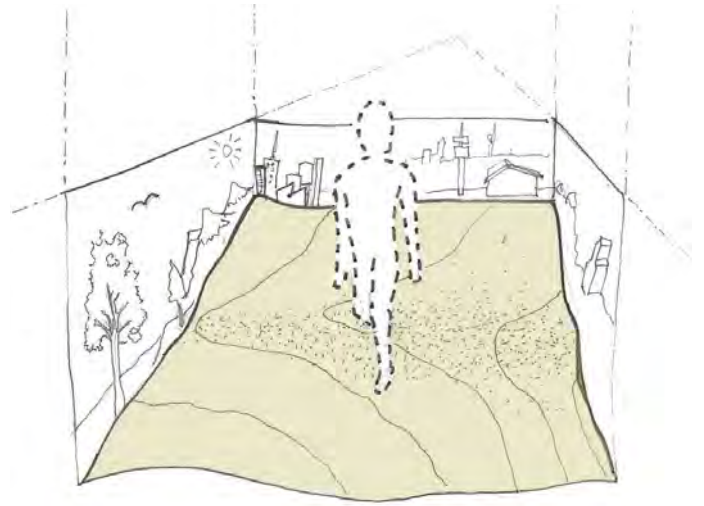


Figure 39 Noteworthy aspects of demolished structures. (Author, 2017)



Genius Loci “The Spirit of a place”

This notion, written about by Christian Norberg-Schulz in his book *Genius Loci: towards a phenomenology in architecture* speaks about the unique character and identity related to a particular place that is so intangible that the metaphysical notion of a “spirit” belonging to that place is put forward in this theory. In a more realistic sense, it can be acknowledged that each place possesses a set of attributes that determines its uniqueness. Alexander Pope said “consult the Genius of the Place in all” and this can be done by identifying and maintaining the components of a place’s identity to guide any architectural intervention (cited in Garnham, 1985). Garnham suggests that these major components of identity are: physical features and appearance, observable activities and functions and lastly, meanings or symbols (Garnham 1985). Maintaining these components is essential since, according to Garnham, “the essential bond between person and place can be broken” if this “Genius” is not guiding new interventions (Garnham 1985:7)



Figure 40 Genius Loci of the Gasworks site. (Author, 2017)

The qualities unique to the Gasworks site that can be identified as it's “genius” are among others:

- 1) Rusted steel industrial artifacts in stark contrast to intrusive vegetation
- 2) Steel and brick construction and the expression of structure
- 3) Austerity brought about by recognizing the absence of demolished structures through their varied remnants
- 4) Abandoned machinery

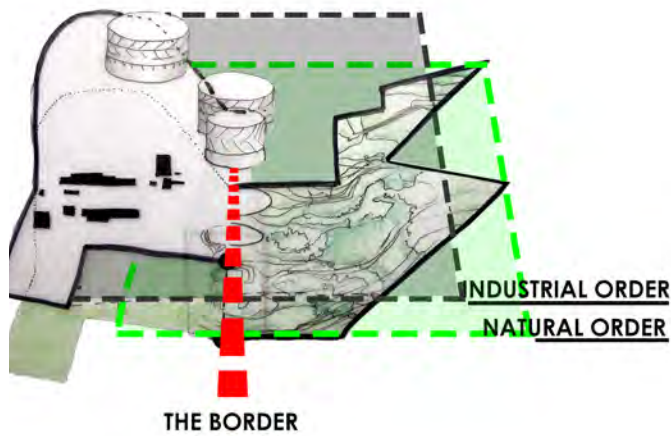


Figure 41 The layering of the Gasworks site and reading the intervention area the location of the overlap (Author,2017)

The site as palimpsest

The word palimpsest means “writing material (such as a parchment or tablet) used one or more times after earlier writing has been erased” (Merriam-Webster 2017) This metaphor is used in architecture to describe the sequential layers of intervention as they have left markings on a site or building.

Thinking of the site as a palimpsest allows designers to utilize the site's layers of history to reveal aspects of the site, or even to add a new layer of self-conscious fiction. Using principles of collage and juxtaposition, history is seen not as linear phenomena, but as layers or discrepancies between a past event (history) and present recall (memory) (Krinke 2001:128)

The potential of reading a site or a work of architecture in its relationship to another layer is made possible in this approach and maintaining a discernible difference between layers is essential to the legibility of these layers and making unscripted imagination possible in the mind of the user. Since the brief of the intervention is the restitution of ecology with industry, a new ecologically sensitive industry is proposed for the site on the location where the gas making process has caused the most damage.

The remnants on the particular intervention area on the Gasworks site serve as a base layer on which to respond. The means by which a demolished building's layer is recognised (it's traces) should be informed by the particular identity or phenomenon of the remnant. Commemorating industrial heritage in this way can “give(s) us the chance to reflect on the use, or rather abuse, of our resources”, (Tempel 2014:142) This speaks about place specific meaning, interpretation and response.

Maintaining a palimpsest of an earlier structure can be done in subtle ways such as recognising a form in paving patterns or material finishes in buildings.

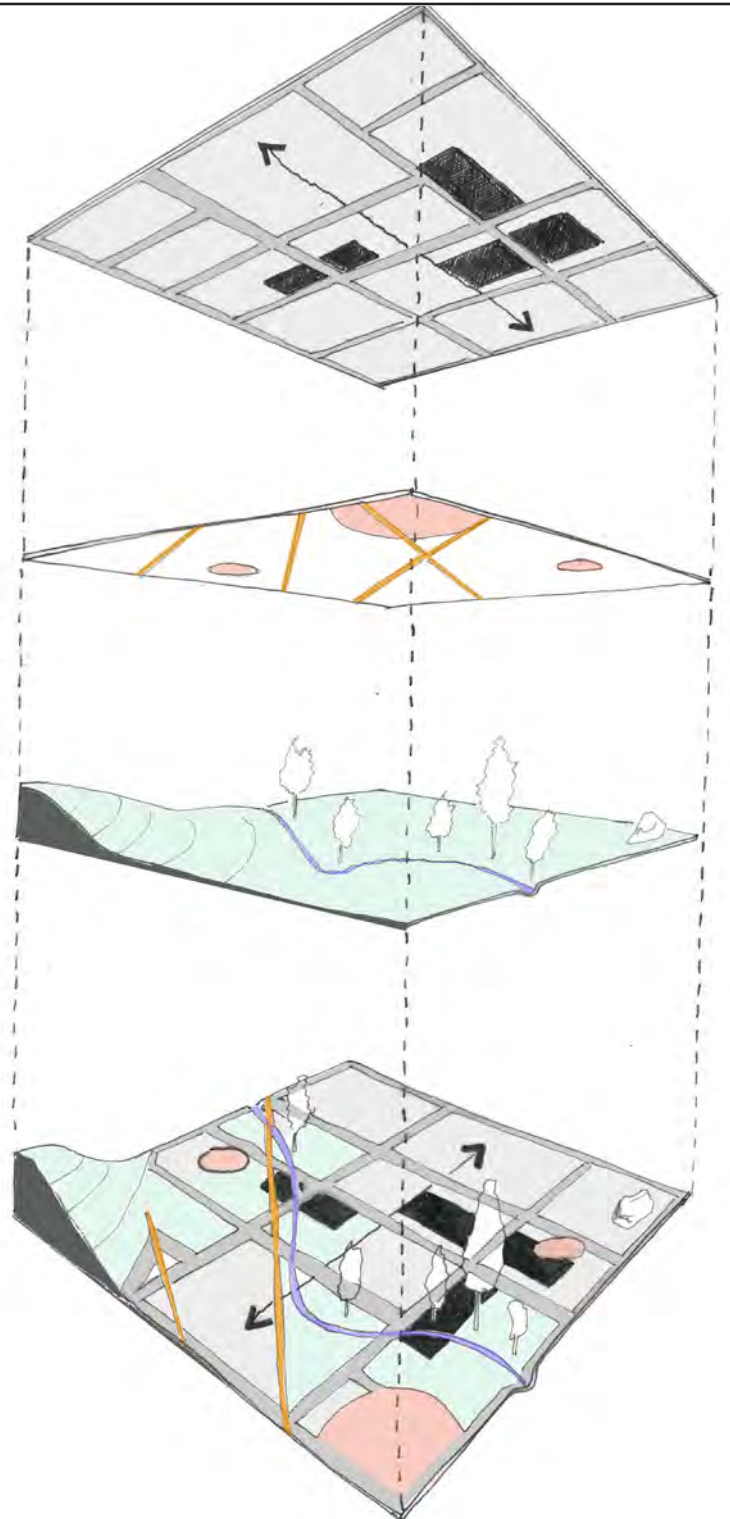
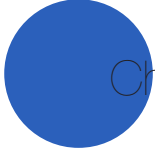
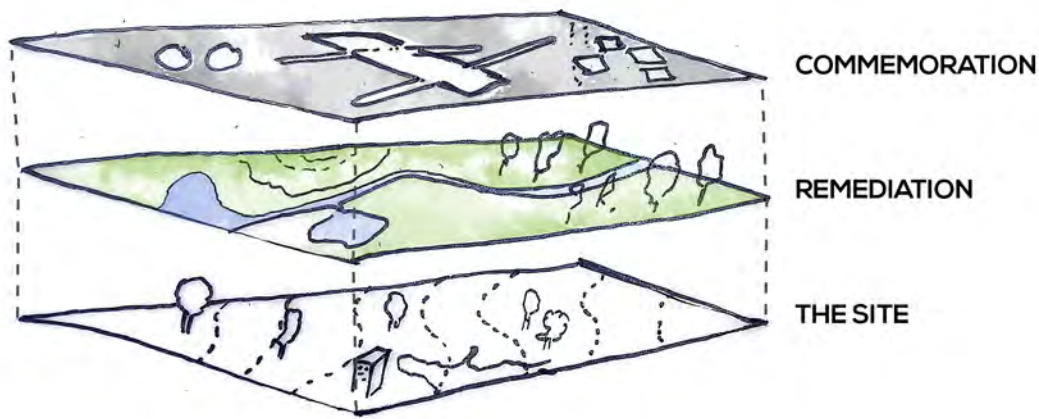


Figure 42 Reading a site as a palimpsest (Author, 2017)



Chapter 4

Precedents



4.1 Crissy field. San Francisco Bay

Approaching the commemoration of post-industrial sites on damaged ecologies by seeing the site as a palimpsest, entails challenging the notion of “restoration”. In his article in *Manufactured Sites*, Rieder accurately illustrates this challenge in his case study on Crissy Field in the San Francisco Bay. The United States Army created the Crissy Fields Air Force base by draining and filling tidal salt marshes along the coast up until 1915. After the base was decommissioned in 1994 the site was handed over to the National Parks Service (NPS). The Natural resource division of the NPS sought to restore the salt marshes whilst the cultural resource division of the NPS sought to restore the cultural heritage that was the World War 1 air field. Since both divisions had as reference a definition of restoration that entailed restoring a site or property to its condition prior to disturbance, the issue that these two conditions had never co-existed in the same period of time became apparent. Restoring the marsh would mean no airfield and restoring the airfield would mean no marsh.

The landscape architecture firm, Hargreaves Associates, addressed this issue by restoring the airfield to its exact position and scale but as a land form. Thus the functioning of the airfield is denied but the form commemorated. With regard to the restoration of the marsh, the opposite approach was taken where the functioning of the marsh was restored but the original form not. In order to ensure that the marsh was fully functioning, the scientists on the project team specified that 8 hectare was the minimum area required to ensure the functioning and health of the marsh. Although the size of the marsh was a quantifiable necessity, there was much

debate regarding the implementation of clearly man-made means to ensure the functional of the “natural” marsh. It was determined that a concrete culvert could assist the marsh in terms of its natural functioning whilst “natural” soil embankments could erode and later threaten the natural functioning of the marsh.

This raised an interesting question regarding conservation and the restoration of that which is “natural”. Are the superficial aesthetic aspects of the environment worth preserving or is it the invisible functioning and services? (Rieder 2001:206-207)

Left:

Figure 43 Layers of intervention at Crissy Field (Author, 2017)

Below: **Figure 44** Crissy Field. Airport2Park. 2014. Crissy Field. <http://airport2park.org/portfolio-item/crissy-field/>





4.2 Landscape Park Duisburg-Nord, Duisburg, Germany

The park at Duisburg-Nord is one of many projects undertaken in the Ruhr district of Germany with the aim to ecologically renew this post-industrial district strewn with the facilities of various industries. Landscape architect Peter Latz undertook the challenge to systematically transform the post-industrial steel manufacturing plant into a park in a way that resonates with the theories mentioned above.

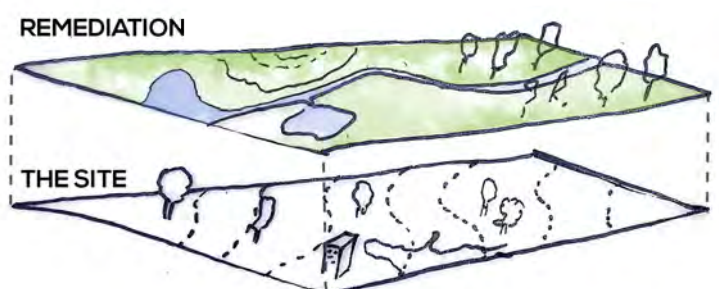
The site as palimpsest. Latz sought to connect the matrix of the buildings and landscapes on site by conceiving them as layers “that are recombined through the lens of park design” (Krinke 2001:136) Achieving the theme of layering also meant appreciating the current qualities of decay of the industrial buildings and landscapes and juxtaposing over that a new layer of landscape interventions. These connections between layers were made by linking elements “either symbolically by gardens or substantially by ramps, stairs and terraces” (Latz 2001:153) Maintaining the integrity of the “Wabi-Sabi” aesthetic as described by Okada is uncompromised at the Duisburg park.

The layering of experience and imagination manifests spatially as well in terms of differing circulation routes and experience at different heights on the site. At the highest level, the park consists of suspended walkways offering a completely different experience than the experience one has at the lowest level - the deep set water park. The layering of the interventions within the park is thus not only historic but also physical.

Reflection and the reversal of meaning.

One of the means through which the juxtaposed layers of experience and history are bound together is that there are relationships between the new and old meanings associated with elements. For instance, heavily polluted soils are not removed from the site but are rather exhibited in their remediated states. Toxic materials and soils are buried deep within ore bunkers, sealed and planted over with roof gardens.

The old Emscher river was a large open waste-water ditch running through the site towards the Rhine river. Latz decided to remodel this river as a channel carrying purified water collected as rainwater off buildings and pavement. These are but two instances in which an intervention in formerly polluting entities were used as strategies that allowed the visitor to view both with new eyes. Thus, remedial action and the commemoration of heritage can be seen as one exercise.



Left: **Figure 45** Park Duisburg Nord, Latz+Partner (Mellado [Sa])
 Bottom left: **Figure 46** Layers of intervention at Duisburg-Nord (Author, 2017)
 Bottom: **Figure 47** Turbine hotel in Knysna, South Africa (Baker, 2012)
 Bottom right: **Figure 48** Cultuurpark Westergasfabriek (Gustafson, Porter + Bowman, 2017)

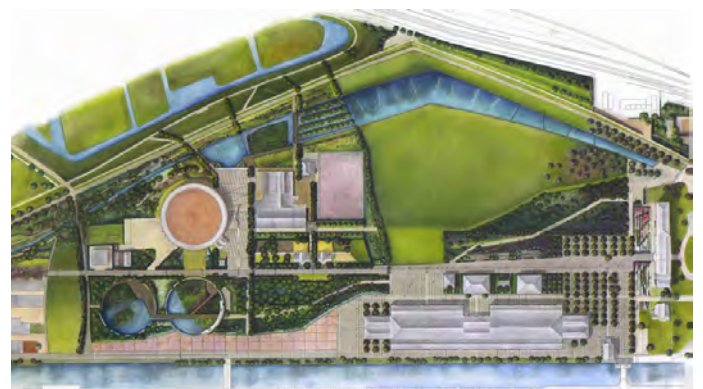
4.3 Turbine hotel, Knysna, South Africa

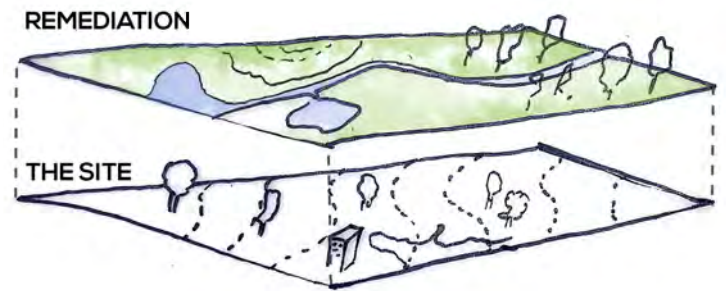
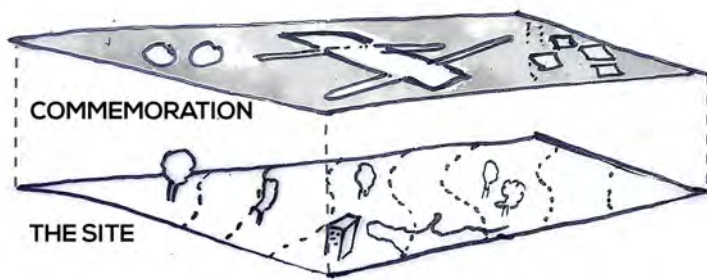
The Thesen Island was a timber mill production unit with a few industrial buildings on it nested in a large wetland area. The site was re-appropriated with the idea of conservation and preservation, it not only hosts a bird sanctuary but human-made canals that criss-cross the development and are home to some rare and endangered species such as the Knysna Seahorse. The Turbine Hotel is one of the conversions of the old mill power station and is especially unique in that much of the first power generation turbines, and fittings have integrated into the hotel design. The main restaurant is especially interesting as you have direct access to two levels to explore the turbines while you enjoy your meal. Some tables are situated just metres away from the old turbine units and create an enjoyable atmosphere. (Baker,2012)



4.4 Westergasfabriek, Amsterdam, the Netherlands

In 1885, the Imperial Continental Gas Association commissioned the construction of the Western Gas Factory near the waterways, railways and roads of Amsterdam. The factory ceased production of gas in 1967 and the site was left in a heavily polluted state. In 1992, the buildings were used temporarily for creative and cultural activities and since then entrepreneurs and artists have flocked to the site. The site was so suitable for the hosting of cultural events that it was later designated as a cultural zone. The site also contains a park and the historic buildings are used by creative entrepreneurs as work space and also for hosting events, musical performances, markets and festivals (Westergasfabriek, 2016)





4.5 Parc de la Cour du Maroc, Paris

This project entails the creation of an urban park from a 4 hectare site containing abandoned warehouses and railway tracks. The landscape architect Georges Descombes utilized the long parallel bands left as traces of the railroad to delineate activities. The new programs are communicated through changes in the ground plane, the planting palette and paths whilst the former function of the site is honoured in the rational and functional layout created by the tracks (MOMA 2008:138). This precedent indicates how the spatial ordering of an industrial process can inform the spatial ordering of a new intervention as a means of commemoration.

4.6 Fresh kills park, New York

The City of New York established the Fresh Kills Landfill in 1948; by 1955 it was the largest landfill in the world. In 1996, a state law was passed requiring that the landfill cease accepting waste after 2001. New York City conducted an International Design Competition in 2001 to foster the development of a master plan; to generate ideas and innovative park designs and respond to the natural and constructed history of the site. Fresh Kills Park, when finished over the next 30 years, will be almost three times the size of Central Park; transforming the landfill into a productive, beautiful cultural destination, making the park a symbol of renewal and an expression of how society can restore balance to its landscape. It will provide a wide range of recreational opportunities, ecological restoration and cultural and educational programming that will emphasize environmental sustainability (New York City Department of Parks and Recreation, 2017).



Figure 49 Parc de la Cour du Maroc (Kopinski [Sa])



Figure 50 Fresh kills park (Ecowatch, 2017)

4.7 The Plant, Chicago

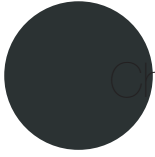
The refurbishment of this 87-year old meat packing factory in Chicago, Illinois entails the introduction of various interlinked systems of production to form a Net-Zero Energy system. This project, partially funded by the city's Department of Commerce and Economic Opportunity, will entail the creation of an urban farm that will grow fresh produce, farm fish, brew beer, produce kombucha and produce electricity from an anaerobic biomass digester that handles about 27 tons of organic waste per day. A noteworthy aspect of this endeavour is the interconnectedness of systems and the role that the Tilapia farm plays within this system. The fish enrich the water with nitrates and ammonia that in turn get circulated to the plant's water system where the water gets purified before being returned into the aquaponic system. (Vinnitskaya, 2012)



Figure 51 Garden and mural (Plant Chicago, 2014)

4.8 Conclusion

The precedents served as points of reference to guide any intervention planned for the Gas Works site. These projects illustrated that commemoration and remediation can be done as a single intervention upon a site. Whether through formal interventions that entailed the adaptation of existing structures (such as the Turbine Hotel) or through landscape interventions (such as the Landscape park or Crissy Field, these projects maintained the Genius Loci of their sites whilst re-establishing them as contributors to the public realm either through recreational activities or new innovative functions.



Chapter 5



Programme



5.1 Identifying the appropriate programme

5.1.1 Heritage and Legacy

As a means to commemorate the heritage of the Gasworks and its identity as a pioneer in industry, it is fitting to propose an industry that seeks to continue and strengthen the genius loci of the site - albeit in a more ecologically sensitive direction. By proposing an ecologically sensitive industry, the site could become a place of learning, where comparisons can be drawn between old methods and new and lessons learned through that comparison.

As part of an urban vision containing four proposals, the commonality between schemes was determined to be that of production. The production of sustainable goods and foods in such a way that the heritage of the site is strengthened.



5.1.2 Restituting industry with ecology on the Gas Works site

It is imperative that the programme of the proposal assists in the remediation of the site itself. A means through which industry can be restituted with ecology is that industry itself becomes the restorer of its own damaging history. The Gas Works site bears testimony to damage brought about by industry, thus in the pursuit of identifying an adequate industry, the remediation of tar polluted soil had to be a consequence of the new industrial activity.

One of the means of this remedial action is the continuous introduction of compost and mineral rich soils into the site and therefore industries were considered which could have compost as an output of its processes.



5.1.3 The presence of water

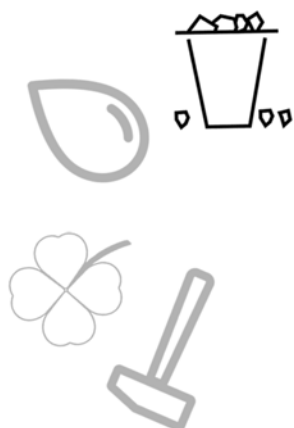
When one understands the morphology of the site before and after the introduction of industry (see Figure 2 on page 11), it is apparent that the surface water, more specifically the tributary to the Braamfontein Spruit, is one of the many ways in which the site was stripped of its ecological richness and potential by underground channelling. Since the re-introduction of water in the form of an exposed waterway is undertaken by a landscape architectural proposal for the same site dealing with purification methods and water circulation beyond the scope of this particular scheme, this project focuses on the potential of water for its meaning and practical implementation.

The associations made with water such as life, purity and ecological richness offer a powerful statement of purification in a scheme that seeks to remediate the legacy of polluting substances such as gas and tar. Since the particular intervention area served as the storage and purification of gas, it is appropriate that the proposal offers similar functions (purification and storage) of this life giving substance. After the importance of the presence of water within the scheme was established, the pursuit for an appropriate programme was focused on industries that were water dependant. In so doing, a meaningful connection between the landscape and the industry could be established in that both were dependant upon the same substance.



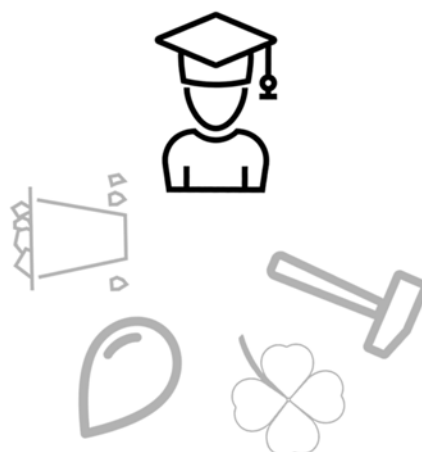
5.1.4 Promoting sustainable urbanism

In Lehman's book on sustainable urbanism, four of the fifteen principles were informative with regard to formulating the program of the scheme. Promoting these principles would also align the scheme with the vision proposed in the Johannesburg SDF for a sustainable future city. These four principles are local food and short supply chains; sustainable transport; landscape, gardens and urban biodiversity and lastly a zero-waste city (Lehmann 2012: 169). Therefore, the programme was expected to gather a waste material from a close proximity to the site and produce a product that would otherwise have been transported from a far location. The waste material identified was organic waste from the collection of restaurants and institutions in close proximity to the site. Campus restaurants of Wits University as well as the University of Johannesburg's catering school opposite the Gas Works site offered great potential for waste collection.



5.1.5 Connection with established networks

As part of the urban vision for the Gas Works site, the isolation of the site from its surrounding urban context had to be addressed by linking programs on the site with established networks in the city. With university and secondary school students being the largest demographic of the immediate surrounding area, it was established that the program required a public component such as a restaurant and recreational area that would assist in drawing students to the site. This restaurant would have to fill a gap within the network of campus restaurants in terms of their dietary provision and this gap was found to be a fresh, affordable source of protein.



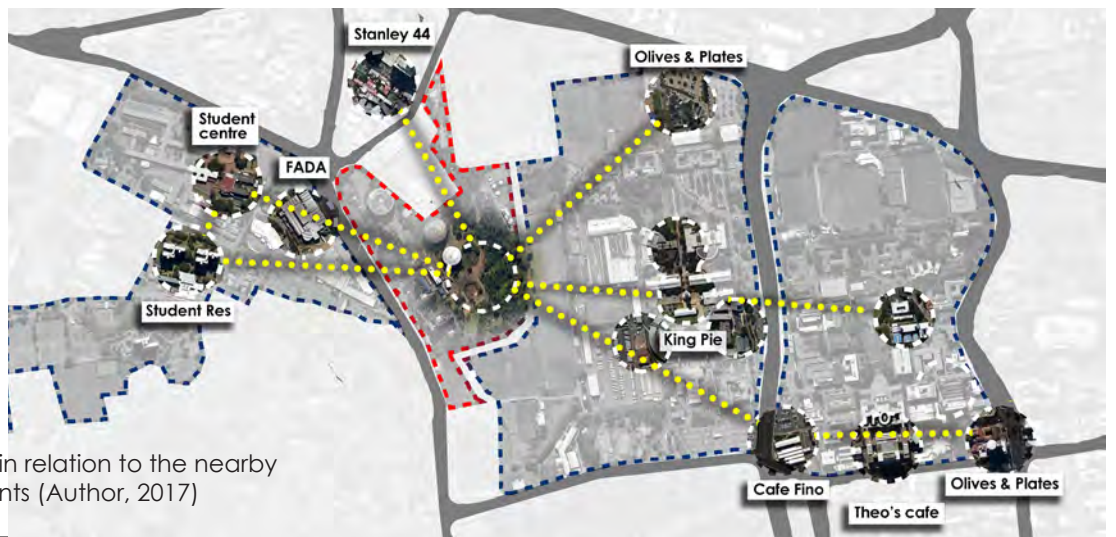


Figure 52 The Gas Works site in relation to the nearby campus and public restaurants (Author, 2017)

5.1.6 The Gas Works and cooking

As mentioned on page 17, a little known aspect of the Johannesburg Gasworks site is its connection with cooking. The Gasworks sought to promote the use of gas for cooking by offering cooking demonstrations on a collection of gas stoves in their showroom. This unique connection to the public collapsed when the Gasworks was decommissioned and is therefore one of the few intangible (unbuilt) aspects of the Gasworks heritage under threat. In the pursuit of a commemoration strategy that captures more than merely the built legacy of the Gasworks, it was decided that the connection with the restaurant network (see Figure 52) can be extended to include the actual processing of the raw product into the edible dish. Therefore, cooking and food preparation was found to be a credible means by which to draw the public and revive a dormant facet of the Gasworks identity.



5.1.7 Conclusion

In summary, the industry proposed for the intervention had to be a productive industry that produces compost, makes much of water, transforms waste, connects with the established network of campus restaurants and offers a product that enables cooking opportunities. Aquaculture satisfies part of these requirements if incorporated into other sub-systems. The incorporation of aquaculture also grapples with the global ecological issue of oceanic fish stocks and the local issue of sustainable food security.

One of the largest ecological issues today is the sustainable harvesting of oceanic fish stocks. Of the oceanic fish stocks surrounding Africa, 80-95% are exploited at or beyond their maximum sustainable yield. In 2015, of the 148 million tonnes of fish captured from the ocean and aquaculture facilities, 15 million tonnes were processed as fish feed and fish oil. (WWF South Africa 2014)

Increased restrictions from environmental pressure groups, have given traditional fisheries very few ways to increase their supply and therefore, intensive aquaculture facilities must meet the growing demand that oceanic fish stocks can no longer sustainably provide. In addition to this, aquaculture facilities should be exploring alternatives to using oceanic fish for fish-feed. Inland aquaculture farming can reduce the carbon footprint involved in transporting fish products to users.

As mentioned in the Johannesburg SDF, water scarcity is a problem all urban centres in Africa have to solve. The recent drought in South Africa has emphasized how food security in this country is contingent on fresh water sources. Bovine farming requires up to 15000 litres of water per kilogram beef supplied (Water Footprint Network, 2017)

As freshwater is being depleted, the need for a sustainable agricultural industry to assist and perhaps incrementally replace the bovine industry is evident. Food security in urban sectors should be addressed by having local food providers in close proximity to urban centres since large supply chains from farm to plate also contribute to carbon emissions from transport vehicles as well as energy usage in maintaining a cold chain in the transport of meat.

Local intensive food suppliers should not have their provision contingent upon water resources. Aquaculture proves very water efficient since breeding tanks can circulate the same water body and only needs additional water to recompense evaporation losses

Site-specific restitution

The site's location offers tremendous educational possibilities for the surrounding school and universities. Showcasing an ecologically sensitive industry was prioritized.

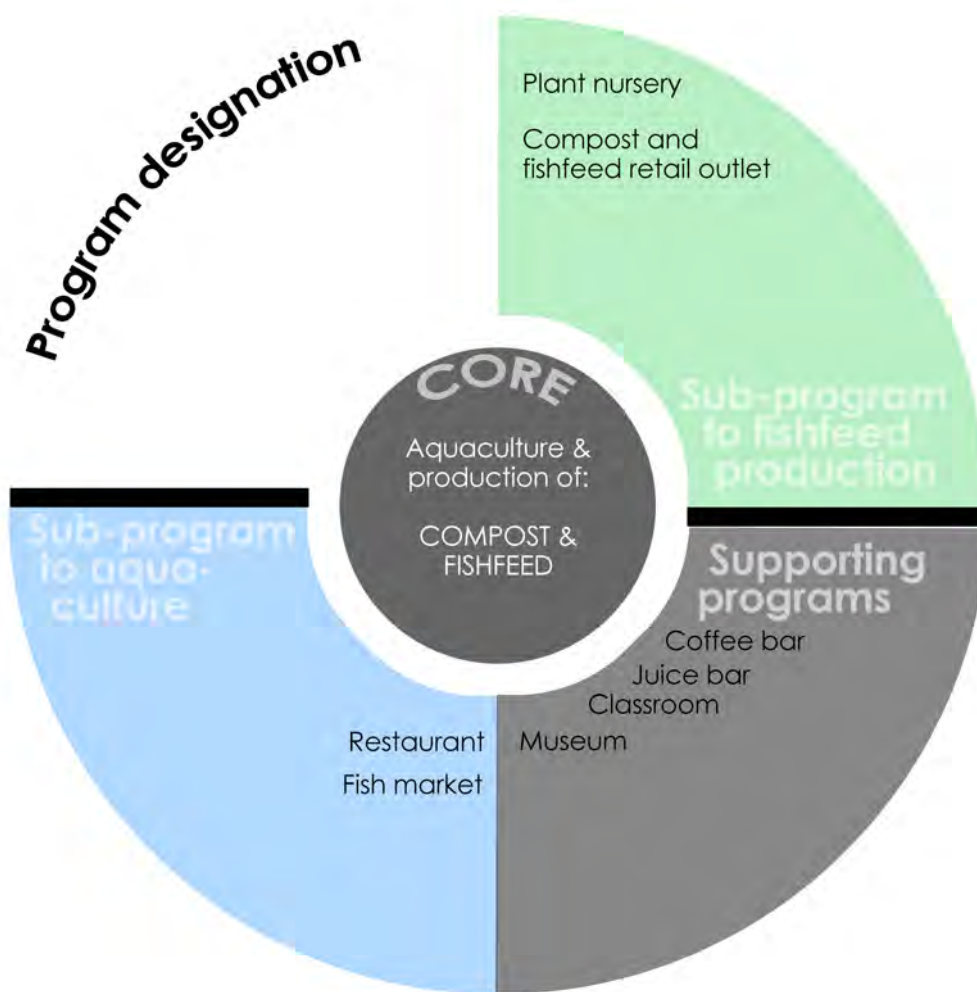
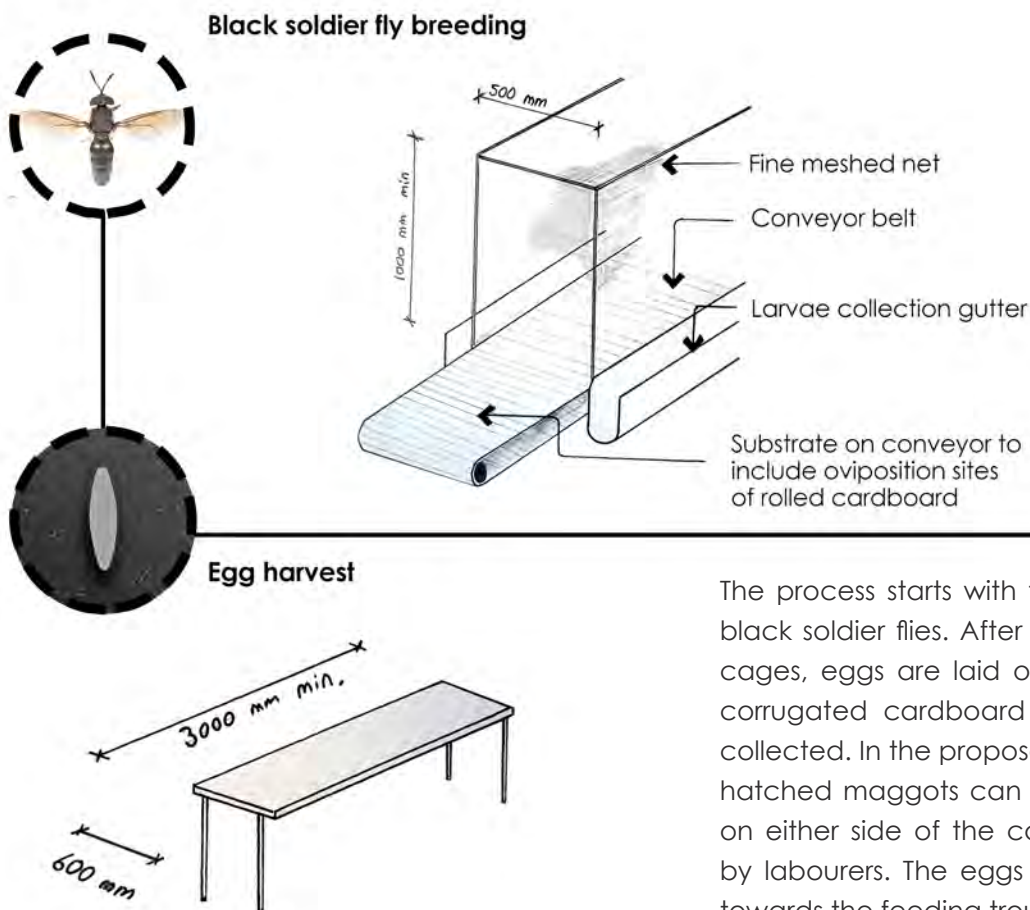


Figure 53 Program designation showing core, sub- and supporting functions (Author, 2017)

5.2

Magmeal - an innovative solution as precedent.

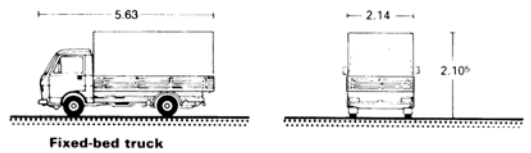
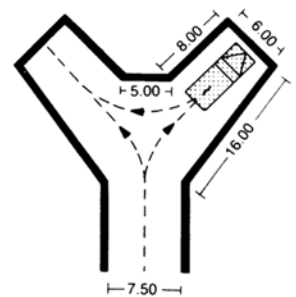
In light of the global and local issue pertaining to food security and fish feed mentioned above, a South African company, AgriProtein has launched a product called Magmeal which produces fish feed from maggots bred from black soldier fly eggs. Although finer details of the exact process is understandably confidential, the principles and their implementation in the intervention area was explored to discover to what extent this core industry could relate to and activate other functions.



The process starts with the intensive breeding of black soldier flies. After breeding in tall breeding cages, eggs are laid on rough surfaces (usually corrugated cardboard rolls can be used) and collected. In the proposal sketched above, newly hatched maggots can scurry towards the gutter on either side of the cages for easier collection by labourers. The eggs are then taken in crates towards the feeding troughs.

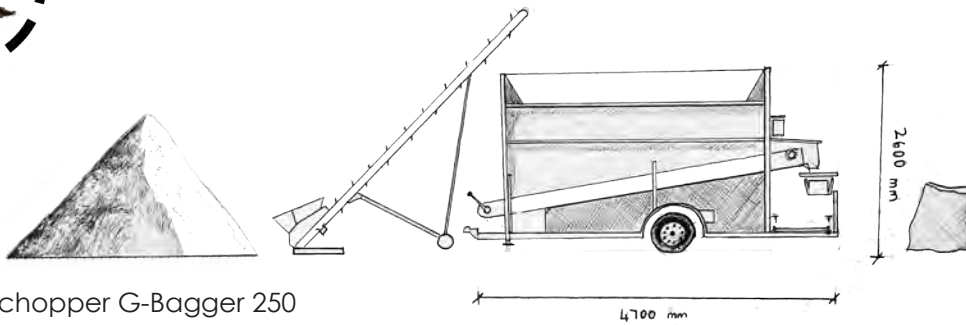
Waste collection

Organic waste, collected from the surrounding restaurants, is delivered via a fixed-bed truck at a waste collection area. This area would have to have sufficient space to facilitate the arrival and departure of the truck. Waste from elsewhere on site such as plant waste from the textile factory and plant based waste from the aromatic plant industry would also supplement the waste collected from elsewhere. A space for sorting the waste and only maintaining consumable waste would be required.



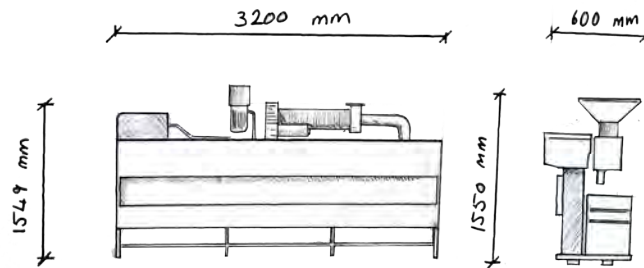


Compost processing



Rotochopper G-Bagger 250

Sorting the compost into bags will enable convenient transport into the park on smaller vehicles and will enable the product to be sold to the public. Similar to cooking, the Gasworks heritage has a unique connection to fertilizer since liquid Ammonia used to be provided freely to any citizen for use in their gardens. The Rotochopper G-bagger 250 was identified as a suitable machine because of its transportability and its relatively small scale.



Davron DTI-464 Tunnel drying oven

Topper TKS - 36D



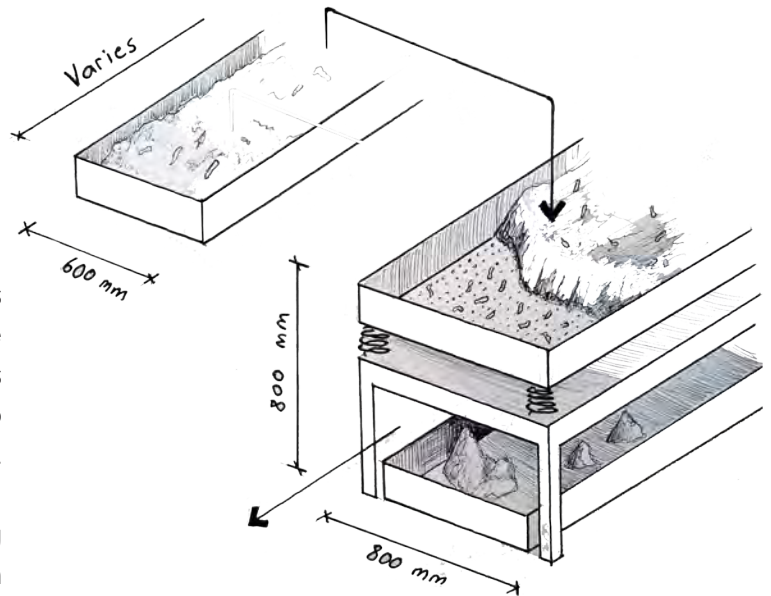
Fishfeed production

Processing the live maggots into fish feed required two stages - baking and grinding. After the maggots have been baked until crispy, a grinder similar to an industrial coffee bean grinder is used to grind them into a powder. Grinding and bagging are both done by the same machine. The powder is then packaged and can be sold at a retail outlet or can be used in the aquaculture facility as a fish feed.

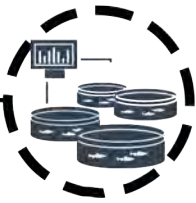
Compost production



In a feeding trough, newly hatched maggots feed on the heaps of organic waste and over the course of 72 hours grow to their full size. As maggots devour the waste, the waste is broken down into maggot fecal matter and a nutrient rich compost. In this scheme, the separation of maggot and compost is realized by incorporating a vibrating table with a sieve. Compost is collected from below and live, full grown maggots too large to fall through the sieve get moved toward the fish feed production area.

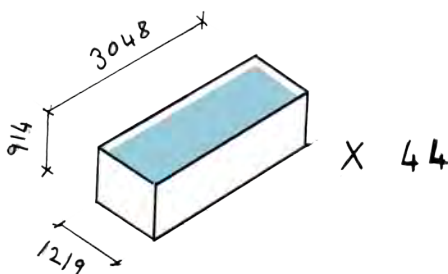


Feed bed + vibrating feed bed



Aquaculture

Tilapia is a warm water fish breed that requires temperatures of between 20 to 21°C for breeding fish and between 18 and 30°C for fingerlings. Before harvesting (for dish preparation) Tilapia would have to be allowed 10-12 months to grow in temperatures of about 28°C. Therefore the calculations for the number of Tilapia tanks required, would have to take into account that there would have to be one year's worth of Tilapia ready for continual harvest.



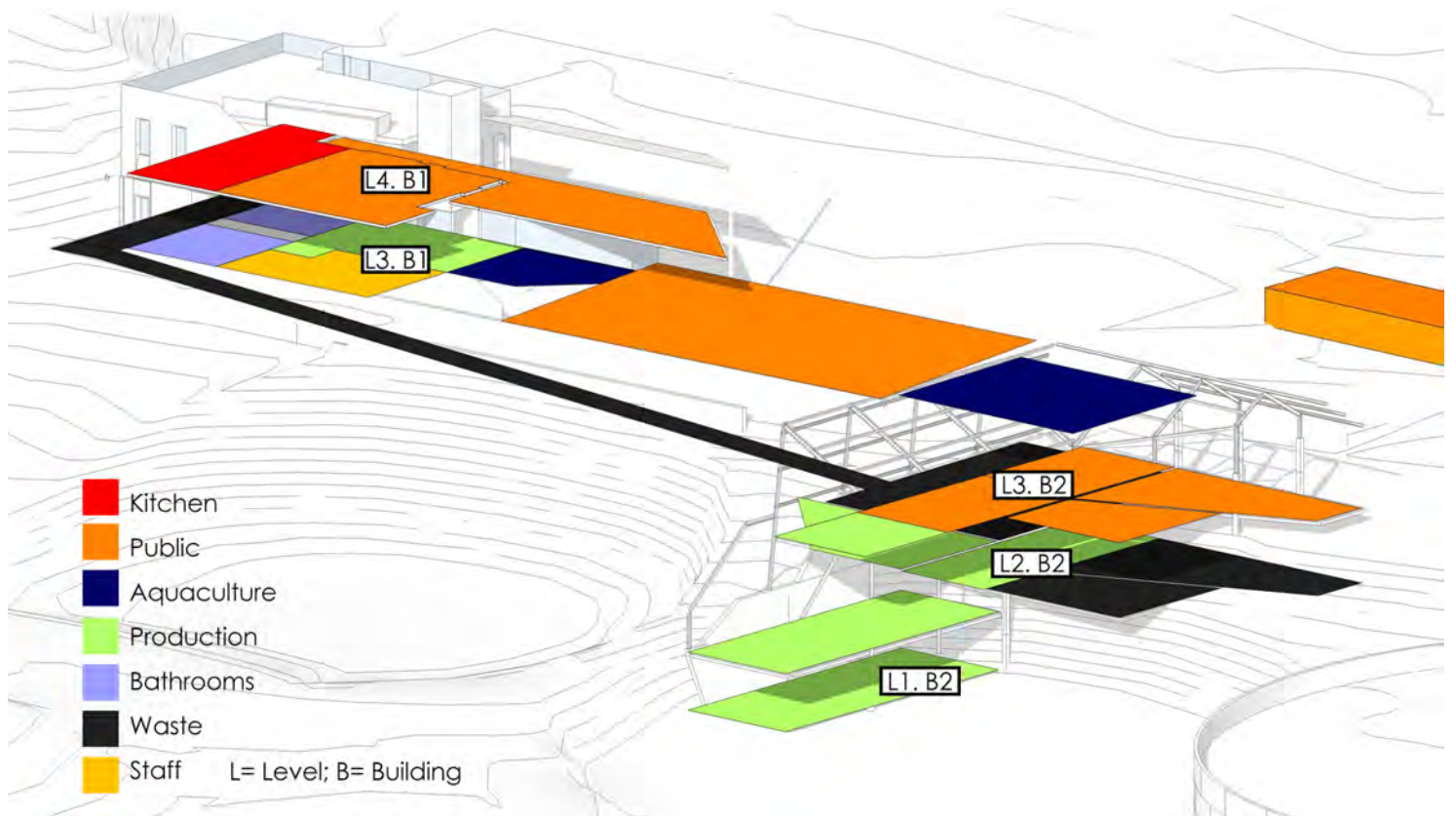
*If the restaurant can seat 66 people seated daily
 = 33 Tilapia prepared per day
 = 167 Tilapia per week @ 800g per fish
 = 134kg/week
 = 6724 Tons/year

Full grown Tilapia have a yield of 45kg/m³ therefore
 6724 Tons @ 45kg/m³
 =149m³ of Tilapia filled water excluding fingerling tanks.

For space efficiency, the FBT rectangular tank by Hydro Composites or similar is considered. Dimensions are 3048x914x1219mm. Therefore, if one tank has a volume of 3.4 m³, 44 tanks measuring 1,2x3m in plan would be required. Tanks need not be separated and larger built tanks of the same volume can also be used.

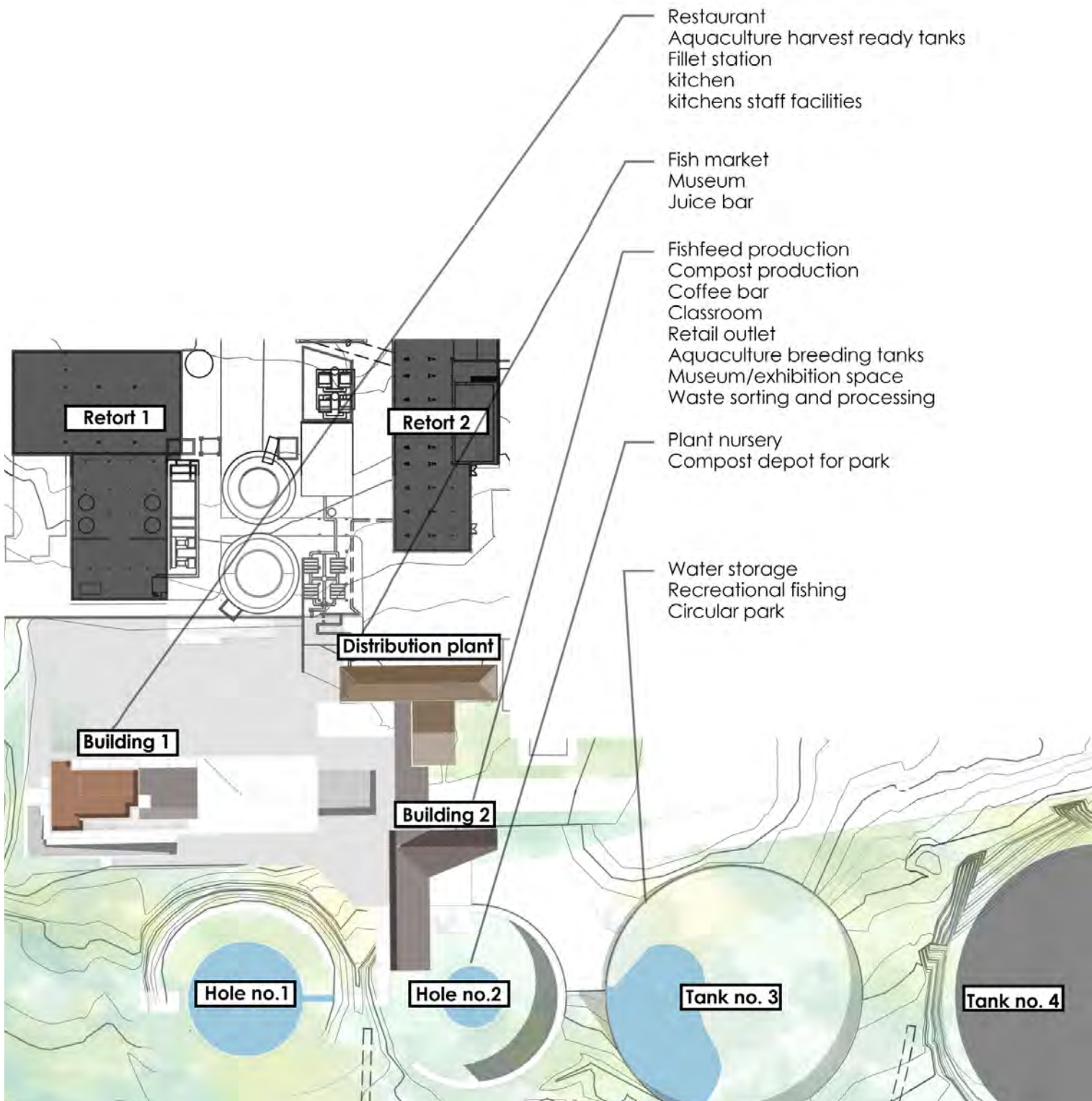
5.3 Programme areas schedule

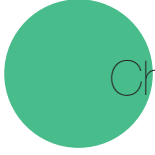
	Private	Observable private	Public
Distribution Plant			
		Area	
		106mm ²	
		48mm ²	
		84mm ²	
Building 1			
Square level		82mm ²	
		59mm ²	
		27mm ²	
		6mm ²	
		5mm ²	
		12mm ²	
		17mm ²	
		7mm ²	
		12mm ²	
Top level		150mm ²	
		30mm ²	
		58mm ²	
		6mm ²	
		8mm ²	
Building 2			
Park level		65mm ²	
		360mm ²	
Mid level		260mm ²	
		41mm ²	
		24mm ²	
		55mm ²	
		93mm ²	
		14mm ²	
Square level		57mm ²	
		56mm ²	
		43mm ²	
		75mm ²	
		26mm ²	



In order to effectively activate the public space between the three buildings involved in the intervention, it was decided that each building should contribute to the public realm on its square level. Therefore, after each required space was analyzed in terms of its size, its placement was determined by the contribution it could make to the public realm. Since waste sorting and maggot breeding give off offensive odours, it was clear that these spaces would have to be separated from the public realm by possibly being partially submerged.

5.4 Programme allocation





Chapter 6

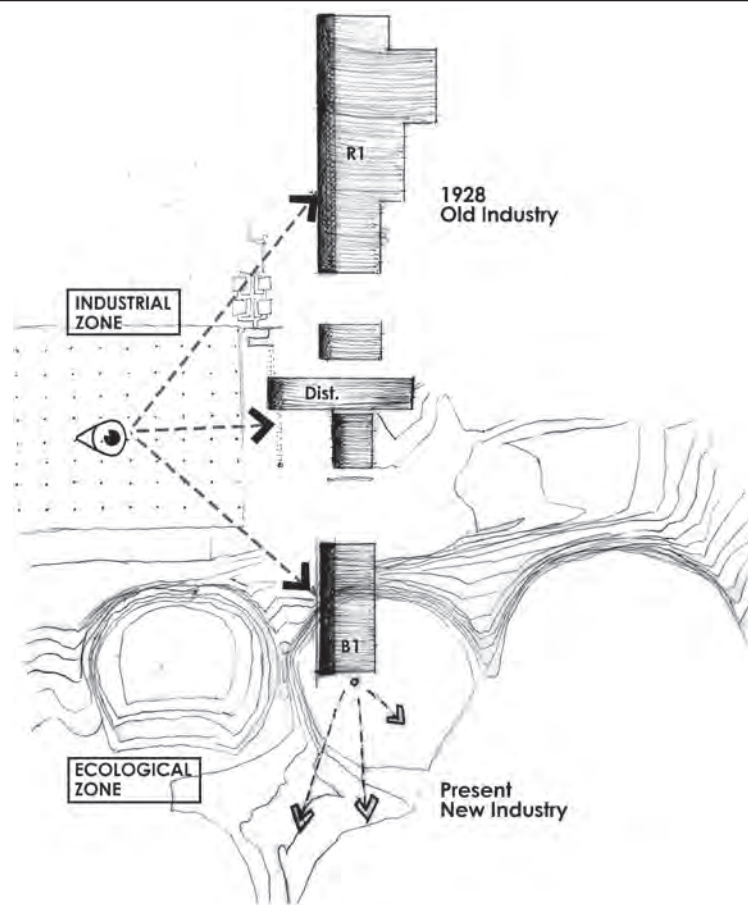
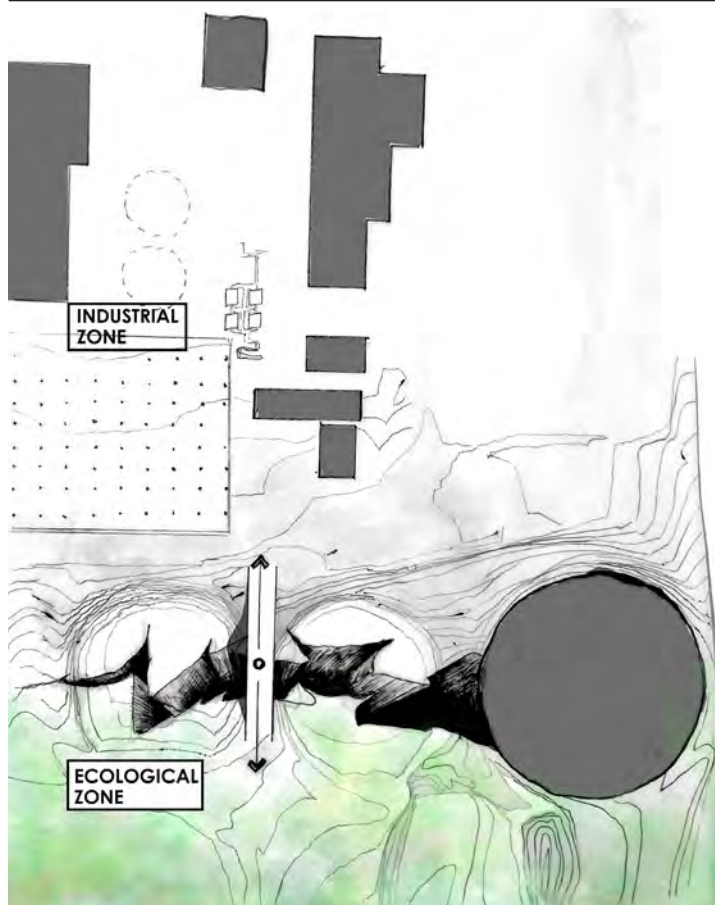
Conceptual Development

Left: Figure 57 The link between Industry and Ecology (Author, 2017)

Right: Figure 58 Building 1 as extension of heritage narrative (Author, 2017)

Bottom: Figure 59 Building 1 as conceptualized mass on site (Author, 2017)

6.1 Conceptual intention 1: Extension of Industry



The intervention area lies in a transition zone between two distinct areas: the industrial “core” to the south west and open green space to the north-east. Tanks No 1&2 and their demolition have caused this transition zone to be a buffer space, a wasted space, where both industrial activity and ecological take-over have been repelled. To address this disconnection, two conceptual approaches are taken. Firstly a literal connection is proposed between these two landscapes and secondly the placement of a built intervention in hole No 2 will seek to showcase the new industry in order to extend the linear narrative of retort No 1 and other buildings and artifacts. This placement will also enable the proposed industry to contribute to the park and extend remedial action into the site where the earlier industrial activity has caused pollution and damage.

6.2 Conceptual intention 2: Responding to the grid

From an early stage in the conceptual development stage, it was apparent that the architectural intervention would entail two buildings. The first entity (referred to in this dissertation as building 2) as discussed in 6.1, communicates an extension of industry as part of a narrative of heritage and Building 1 found its conceptual inception as a response to the purification plant grid. To form a legible association between the existing ruins (column grid) and the new intervention, Building 1 was envisioned as an extension of this grid.

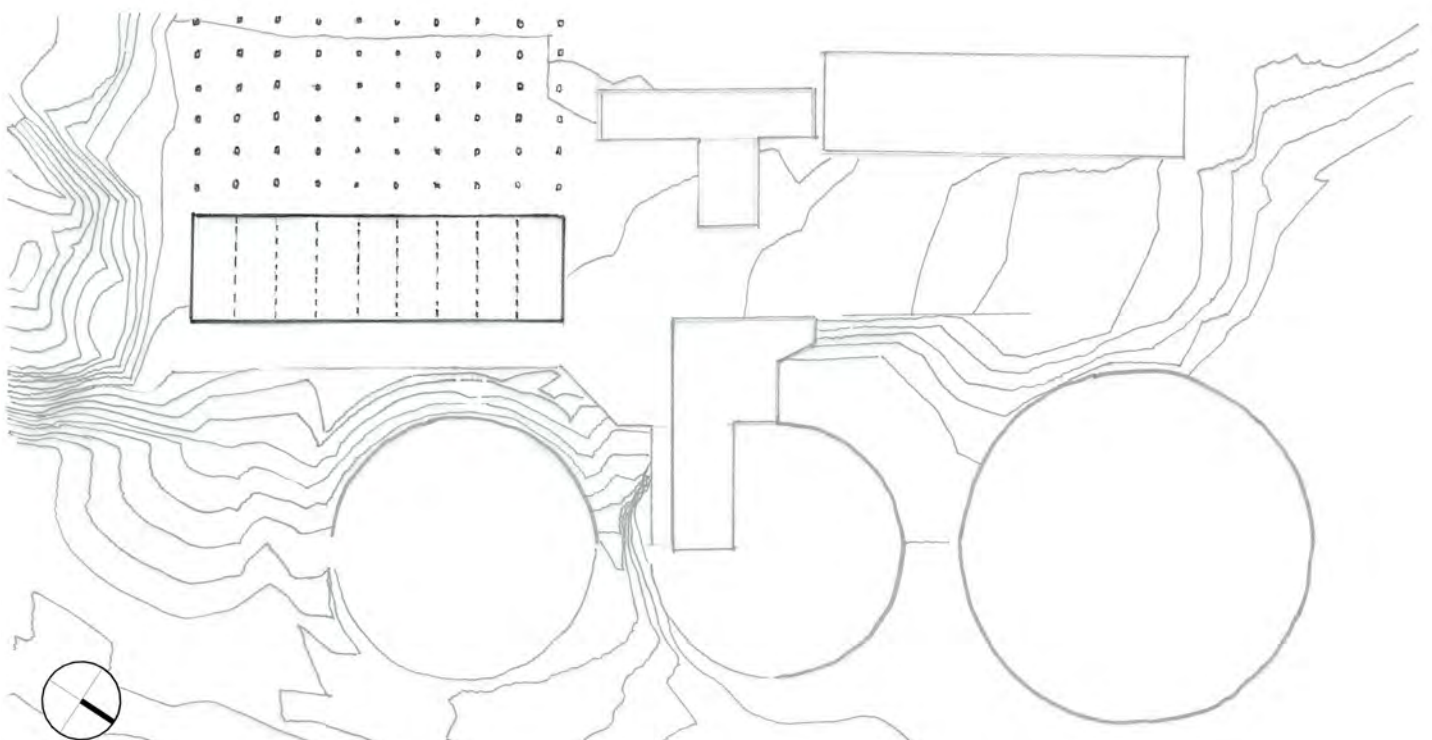


Figure 60 Responding to the grid as conceptual response (Author, 2017)

6.3 Conceptual intention 3: Movement along the grid

Another conceptual influence for the design of Building 1 was the potential of the approach towards the building to be a didactic experience where the user would reflect on the grid whilst being drawn into the building. This line of movement was envisioned as an ascension that would be facilitated by the building and culminate in a large vista over the landscape. In so doing, the building's circulation and views could be closely tied to both its immediate heritage fabric and the park.

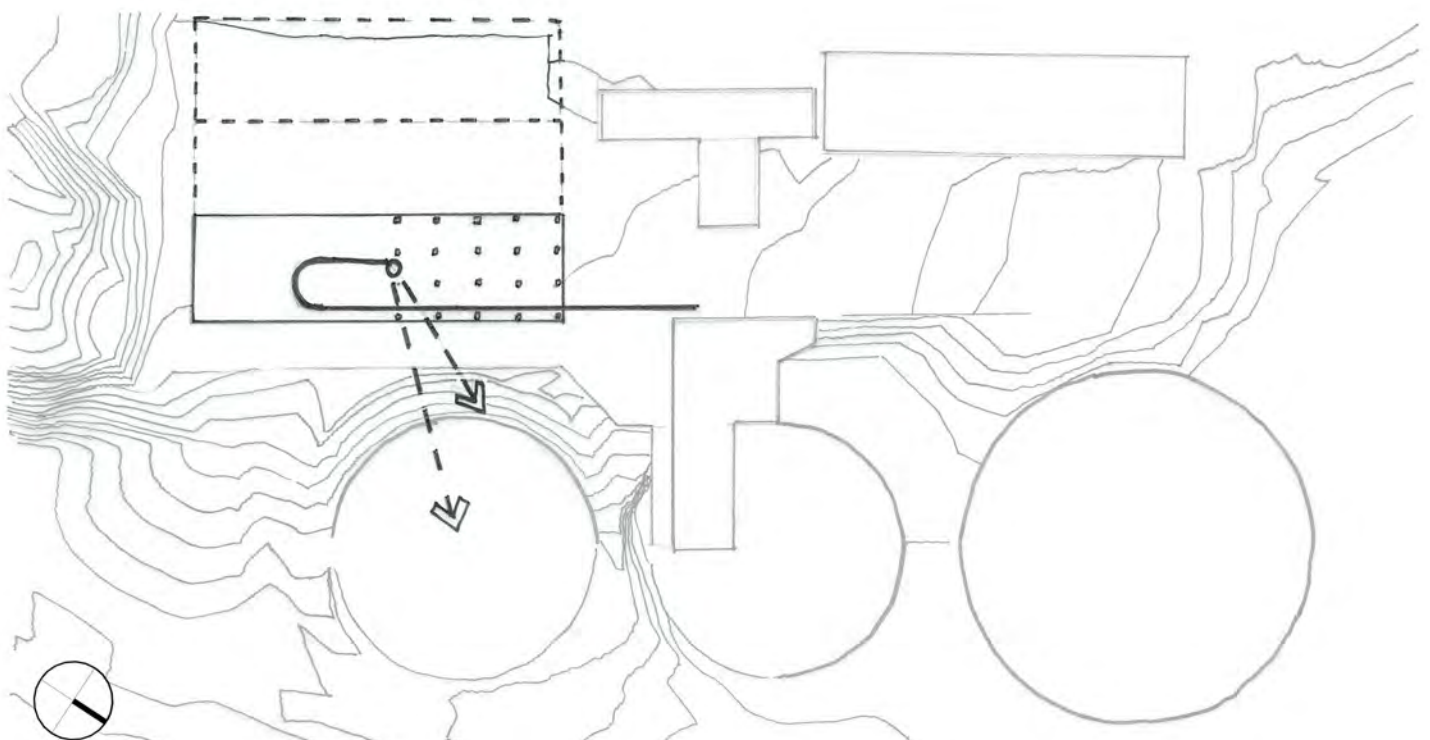


Figure 61 Movement along the grid as conceptual response (Author, 2017)

6.4 Conceptual intention 4: Water-based recreation

Through Latz' intervention at Duisburg-Nord recreational activities were proven to be effective ways to script new associations with heritage fabric in the minds of users. The northernmost half of the Purification plant footprint was conceptualized as a foyer space to the entire scheme that ties together aspects of heritage, recreation and aquaculture. This aim would be realized in the implementation of a recreational water park that forms a recreational association with water other than mere functional or aesthetic purposes.

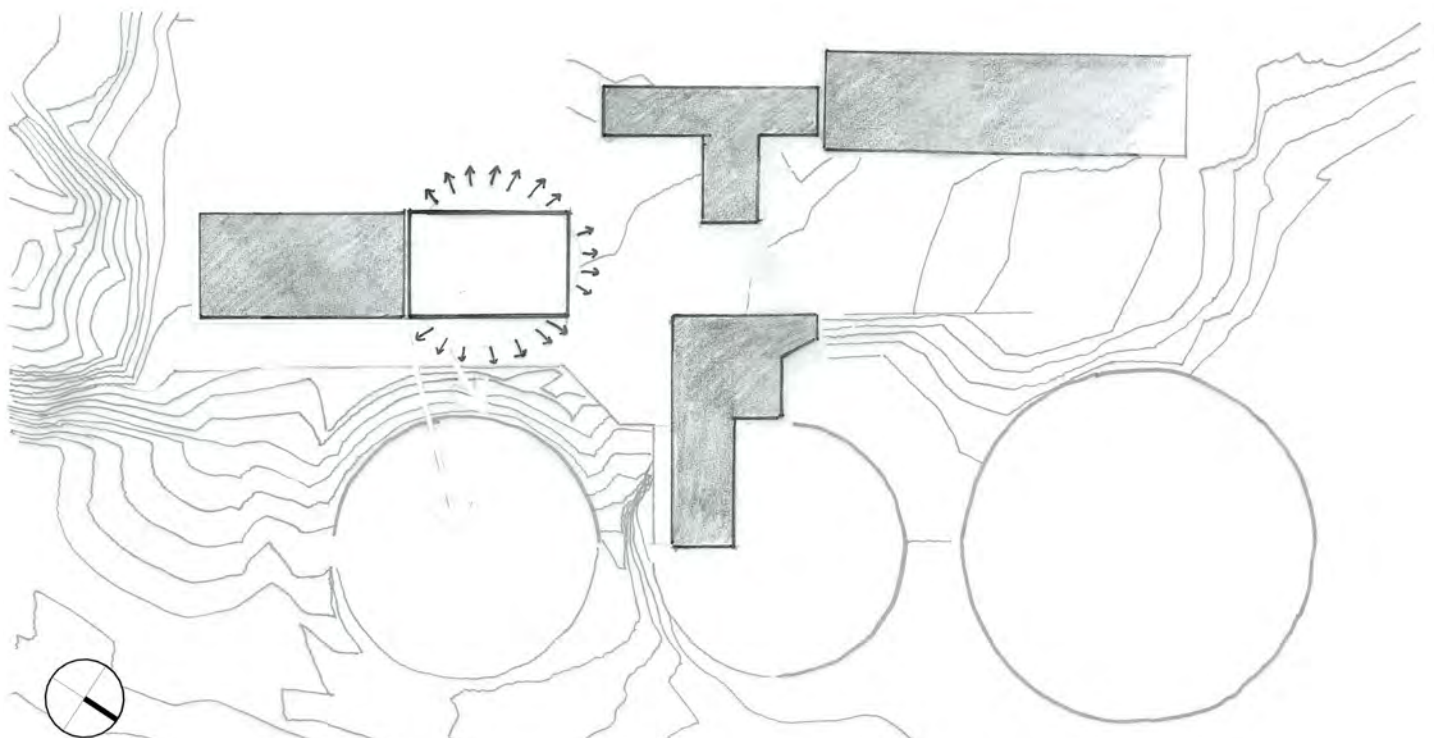


Figure 62 Water-based recreation as conceptual response (Author, 2017)

6.5 Conceptual intention 5: Cohesion through geometric order

One of the unique attributes of the Gas Works is the manner in which the ensemble of buildings formed cohesive spaces in between them that were ordered according to their purpose within the sequence of the coal to gas process. In order to tie into this ensemble in a legible way, it was prioritized that the intervention should be ordered according to the geometric cues offered by the existing structures. In so doing, experiencing the site would mean relating new architectural interventions to existing structures and thus drawing more attention to their significance.

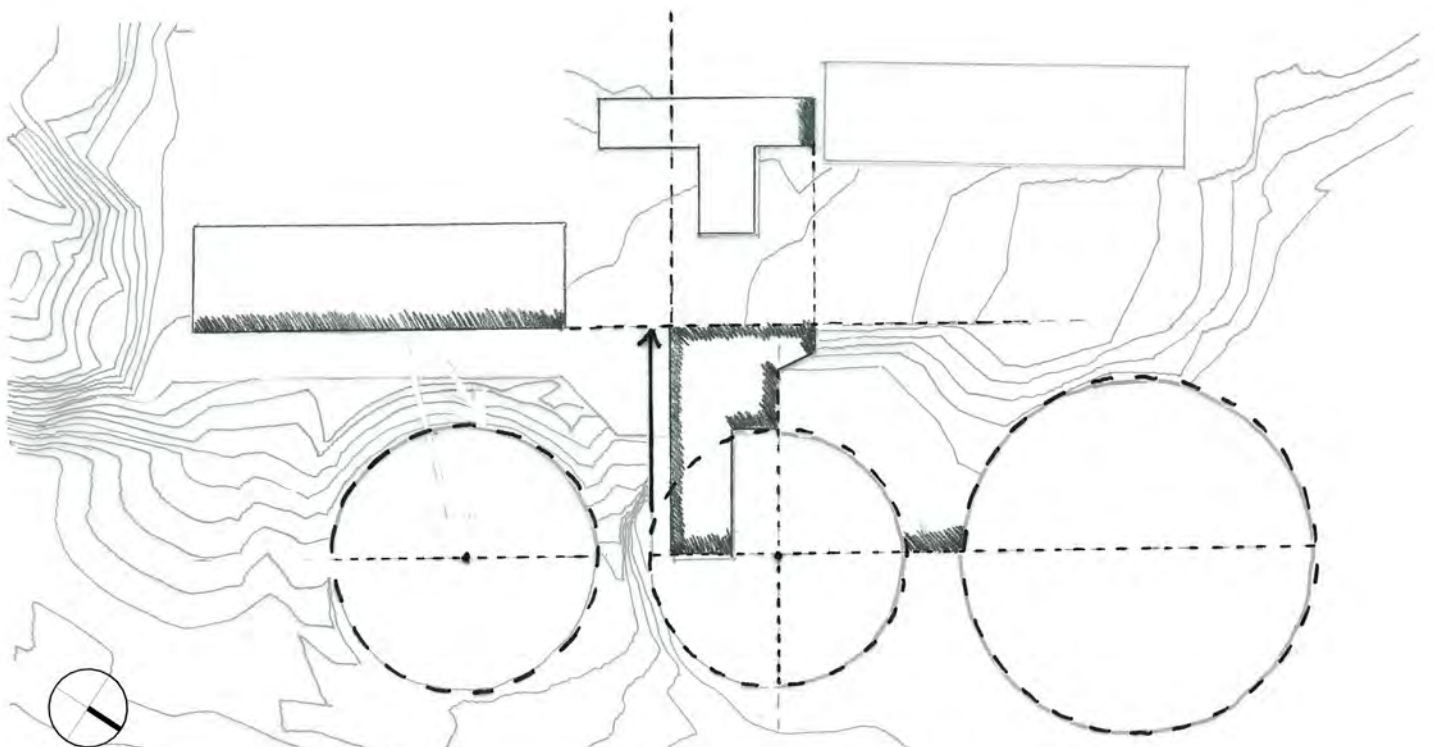


Figure 63 Cohesion through geometric order as conceptual response (Author, 2017)

6.7 Synthesis of conceptual intentions

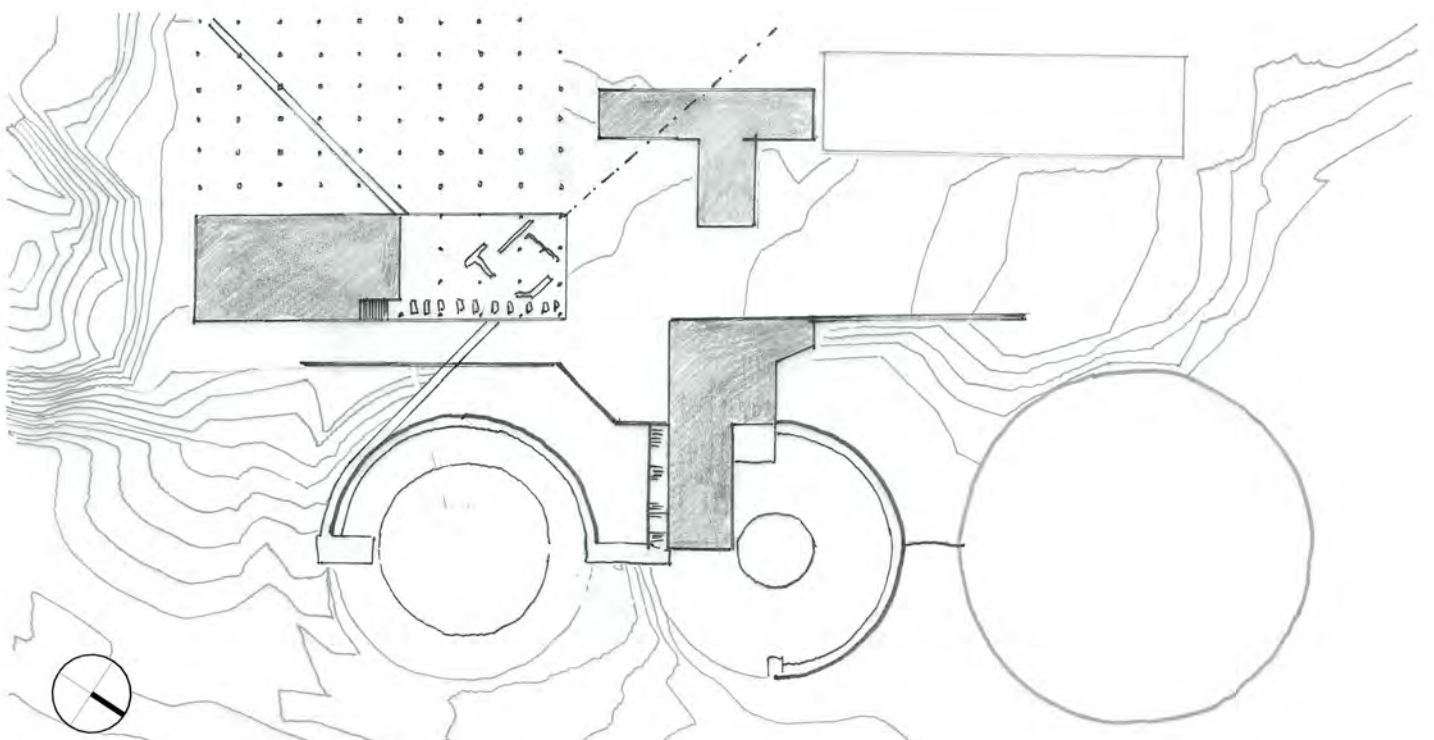


Figure 65 Synthesis of conceptual intentions (Author, 2017)

6.8 Place-specific conceptual approaches

In the pursuit of translating the theoretical stances mentioned before into design intentions, the distinct places within the chosen intervention area were investigated. The intention is to investigate how formal outcomes can come from applying theories on palimpsest, the aesthetic of austerity, Genius Loci as well as appropriate heritage approaches. Since these places and the threats and possibilities they offer vary greatly, it was decided to approach the site as a series of layers of intervention as this would also tie into the theoretical stance of reading the site as a palimpsest.

The plateau on which the purification plants stood offer numerous rusted steel and concrete foundations on which to respond, whilst the holes from the No 1&2 gas tanks present threats of soil erosion and soil pollution. Therefore, the two issues grappled with in these two instances are commemoration and environmental remediation.

The No 3 gas tank offers the challenge of appropriate re-purposing strategies. The investigation into zone 2 (see Figure 67) seeks to identify how place specific heritage considerations can guide placement of new structures within the entire intervention area. Therefore, the investigation into the first zone will aim to resolve coherence with both heritage fabric and other architectural proposals that form part of the Gas Works site proposal.

Above: **Figure 66** The intervention zones (Author, 2017)

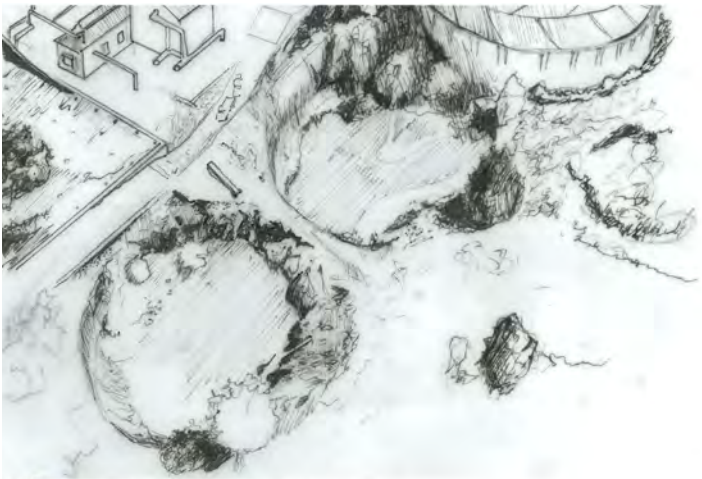
Right: **Figure 67** The intervention area (Author, 2017)



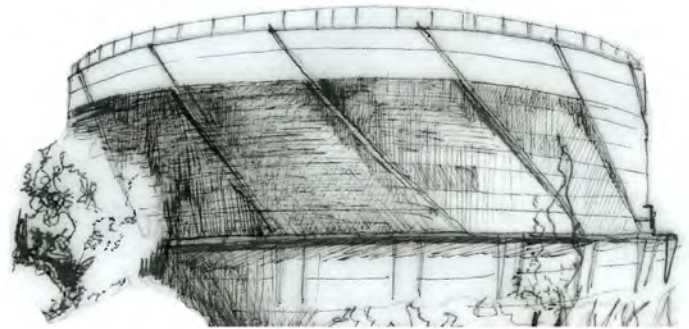
① Order within the intervention area



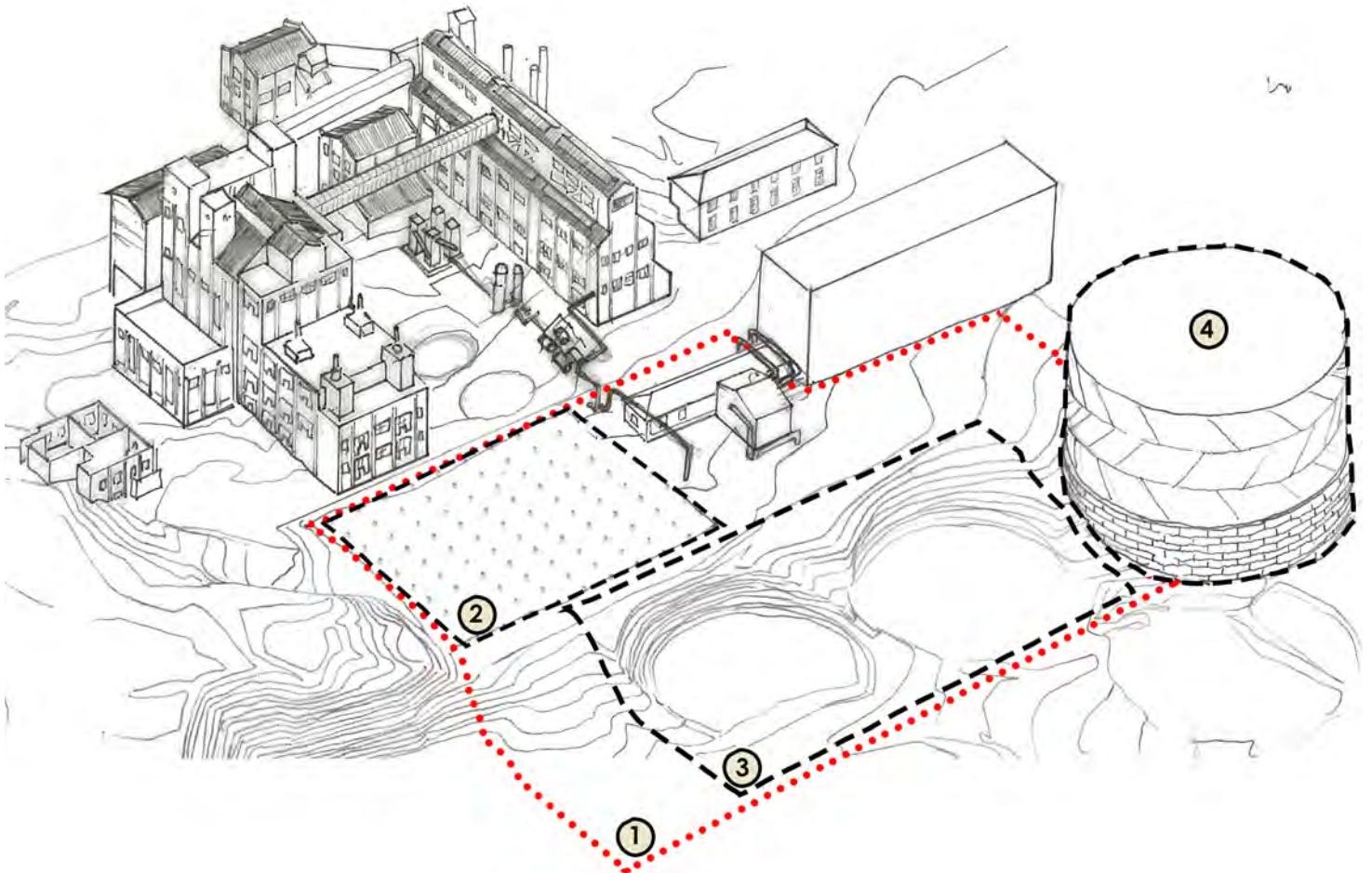
② The purification plant plaza



③ Nr 1 & 2 gas tank holes



④ Gas tank Nr 3



Site intervention as a palimpsest

Employing the theory that a site can be read as a series of layers written upon one another not only means that the Gasworks site can be read in its various layers of history and transformations but also that any new intervention can be applied in a series of layers. This is a necessary approach in the intervention area since there are various issues/opportunities that need to be addressed and which seem unrelated at first glance. The conceptual development of the intervention thus addresses all the aspects that the restitution of ecology and the heritage of industry require.

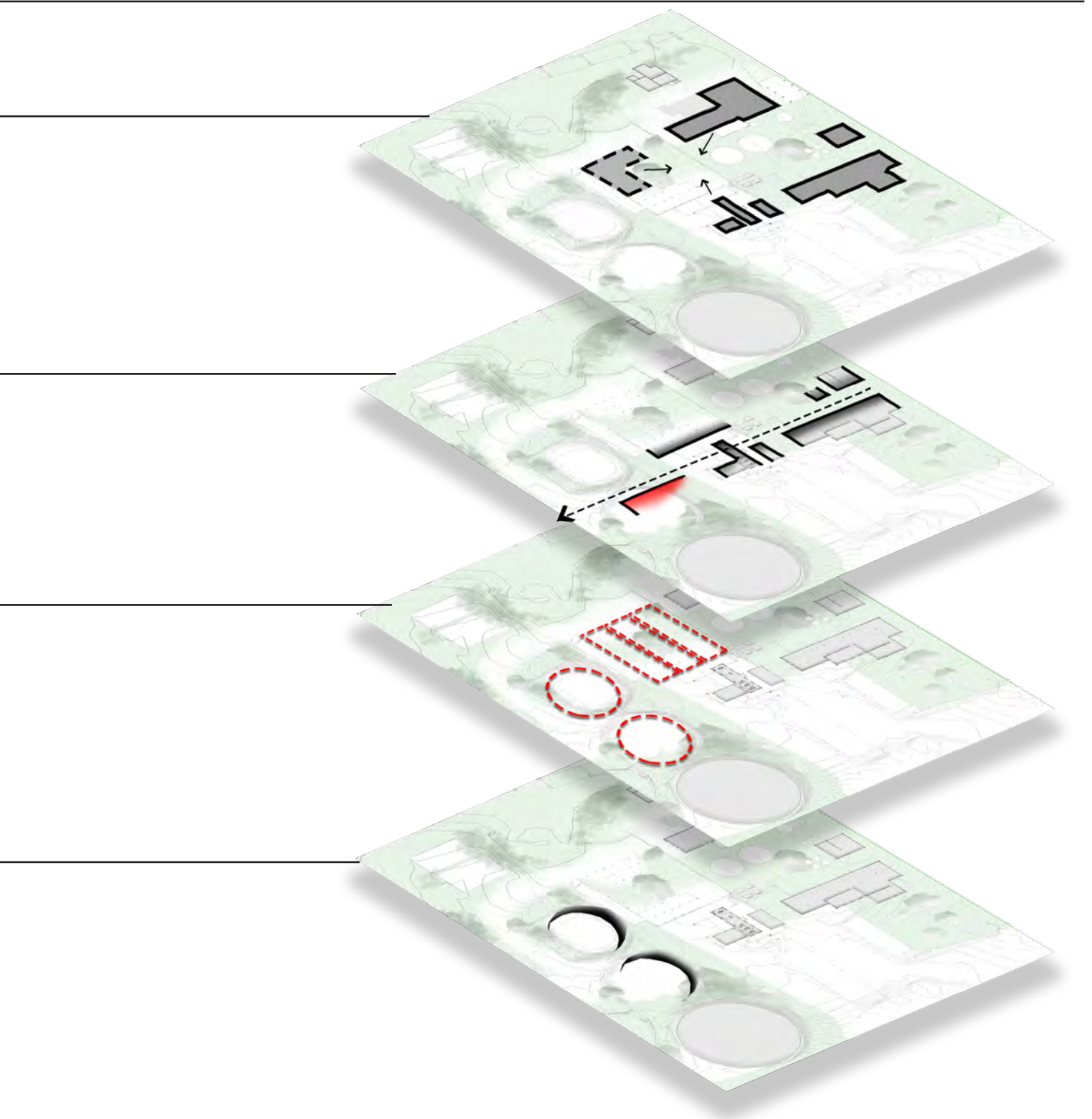
The first two layers of intervention would need to respond to the current condition in terms of soil pollution and industrial remnants. After soil stabilization and the appropriate acknowledgment of demolished structures have been planned, the third layer would entail formal heritage responses that would dictate the placement of one building. This building would signify the progression of industry towards more ecologically sustainable means. The fourth layer builds upon the commemoration strategies of the second layer by activating the public spaces that are currently undefined. Activating and defining these spaces would seek to restore the broken coherence of the site (refer to Figure 32 on page 29). Illustrating a co-dependence between two buildings would strengthen the Genius Loci of the site where an ensemble of buildings forms the whole and therefore from the onset the possibility was there that two buildings might be required.

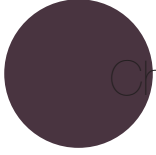
4) Restore broken coherence

3) Formal heritage responses

2) Commemorate demolished structures

1) Employ remedial actions for erosion
and soil pollution





Chapter 7



Design Development



7.1 Intervention layer one - remedial action

The first layer of intervention upon the site entails the remediation of the physical terrain as a “base” layer. However, this intervention also serves as an opportunity for the next layer of intervention (formal heritage responses) to respond to and build on.

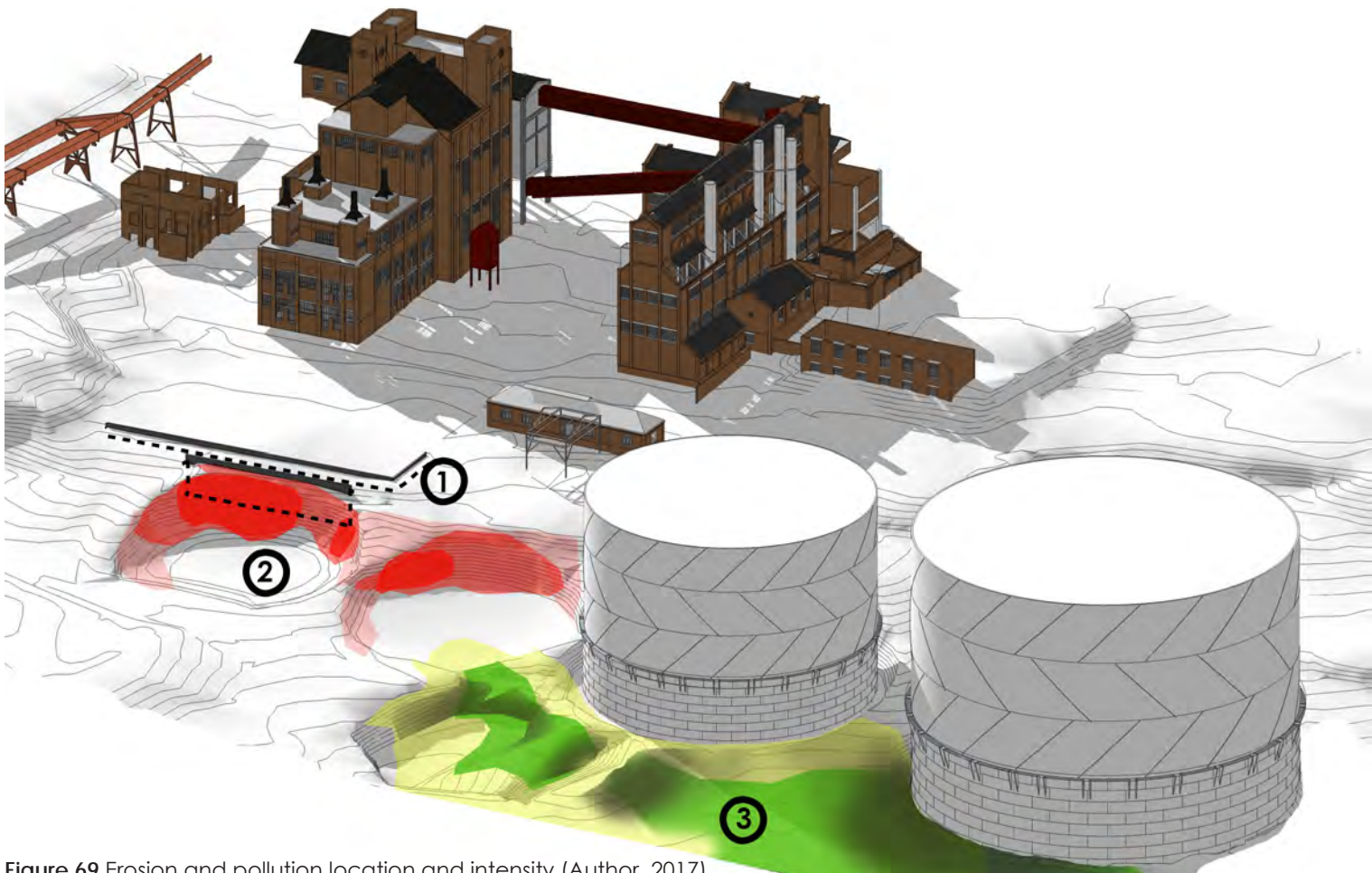


Figure 69 Erosion and pollution location and intensity (Author, 2017)

Place-based design interventions & opportunities

1) Existing structures

The purification plant required vehicular access and thus a road was constructed between gas tank No 1 and the purification plant. After demolitions in the 1990s, there are currently two walls remaining in this area - the foundation walls of the plant itself as well as the retaining wall used for supporting the road. As mentioned in the conceptual development chapter this wall is deep enough to be used to support newly built interventions, especially interventions that require excavation

2) Erosion - appropriate remedial intervention

The diagram on the left illustrates the degree of instability of the hole's edges. Since the heritage value of these holes lie in their formal recognition of the gas tanks and not the soil itself (since the soil is backfilled soil and not virgin soil) it was decided to stabilize the edges with semi-circular retaining walls that support ramps that connect the park landscape to the heritage square.

3) Pollution

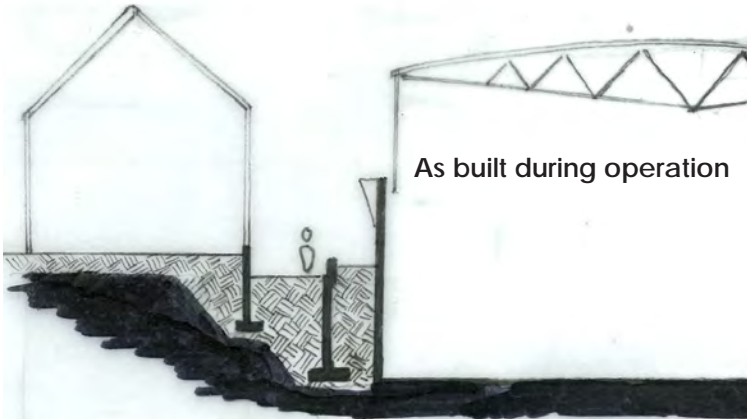
The yellow and green areas shown in Figure 69 highlight the location and intensity of tar pollution in the soil. It was decided to excavate to a depth of 1 meter below the pollution layer within the envelope of hole no 2 and to cap the polluted soil outside the envelope of hole no 2 with topsoil. By doing this, not only is the threat of contamination removed but the envelope of the demolished tank is more clearly celebrated.



Figure 70 Hole 1 edge condition. Photograph by Author (2017)

Figure 71 Tar pollution within soil. (Tsica archive, 2017)



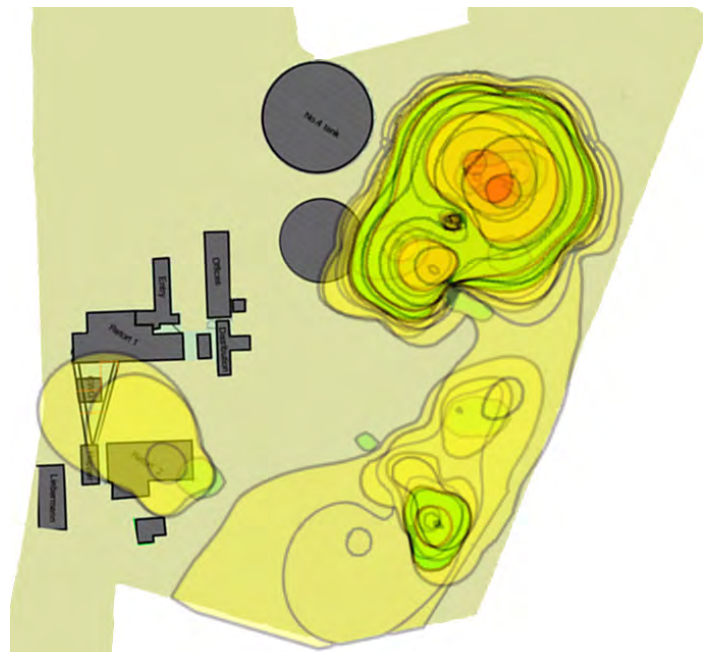
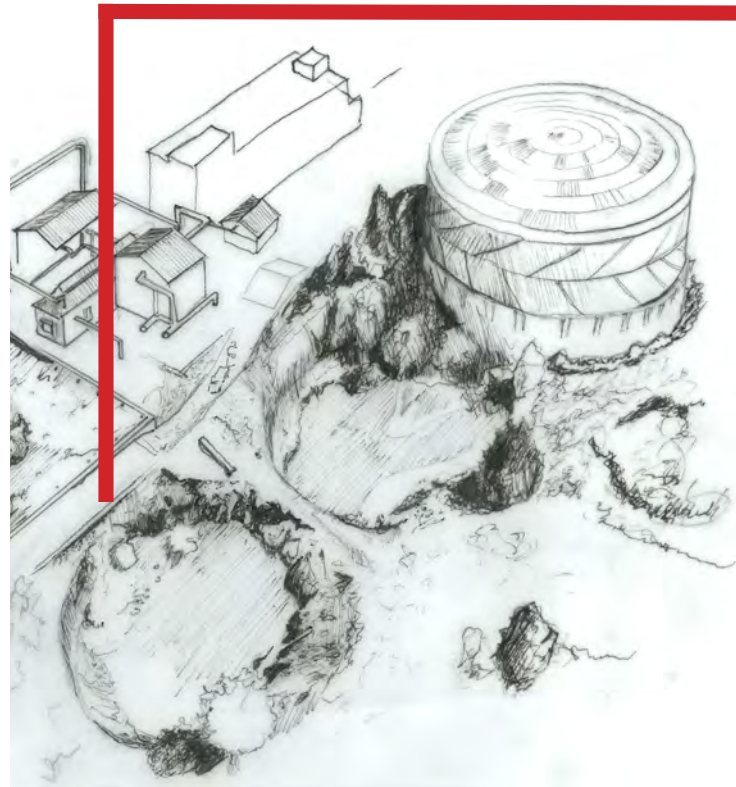


➤ The No 1 & 2 gas tank holes

Before conceptual design drawings can be made of possible interventions within the two holes, the condition of these two holes has to be understood. As can be seen in Figure 75, soil pollution affects hole No. 2 and therefore the remedial measures illustrated in Figure 76 are deemed adequate. Areas affected by pollution should either be covered by topsoil or excavated to a depth below the polluted soil layers. Although hole 1 is not polluted, its edge condition and rubble mounds from dumping have also made stabilization of the soil and earth-moving necessary.

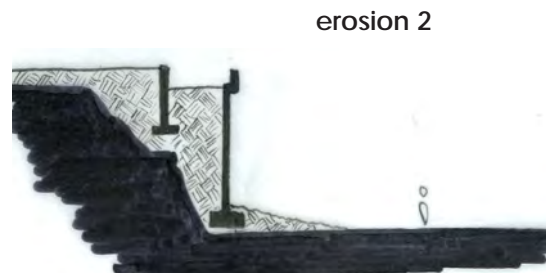
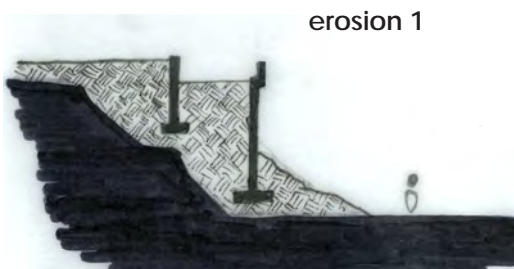
It is assumed that the wall seen in Figure 74 would have been built to a depth that would ensure its stability. Therefore, the soil seen in Figure 74 could not be virgin soil but rather infill dumped in between tank No 1 and the retaining wall. Although this face, left undisturbed, would have satisfied the theory behind the austerity aesthetic, it is inevitable that the soil would continue to erode away from the wall. In order to stabilize it, a new retaining wall is required that could also serve the purpose of commemorating the presence of the tank.

This exercise would be similar in approach to the Crisy Field example where commemoration and environmental remediation of the marsh were seen as one design exercise.



Top: **Figure 72** Sketch illustrating soil displacement as tank 1's construction, the present condition of hole 1 and the future conditions. (Author, 2017)

Above left **Figure 73** Hole 1 and 2 sketch (Author, 2017)



Above right: **Figure 74** Photograph of hole 1 edge (Author, 2017)

Bottom left: **Figure 75** Diagram of pollution on site (Author, 2017)

Bottom right: **Figure 76** Section through hole 2 indicating pollution and remedial actions (Author, 2017)



Hole 2 longitudinal section indicating pollution depth and position



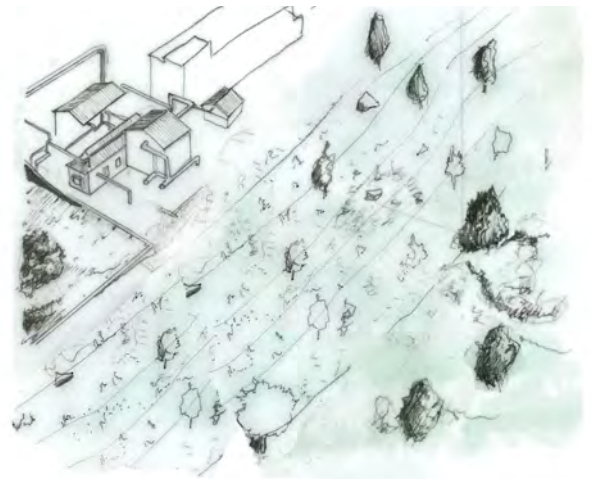
Remedial action 1:
Excavation to 1 meter depth



Remedial action 2:
Addition of clean topsoil.

Right: **Figure 77** Pre-industrial, mid-industrial and proposes post industrial conditions. (Author, 2017)

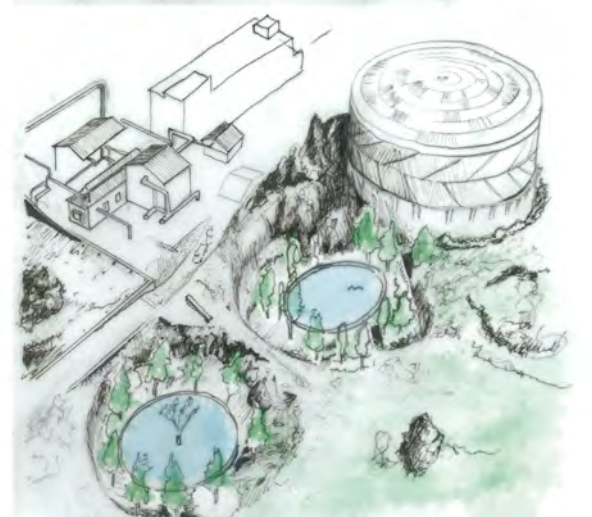
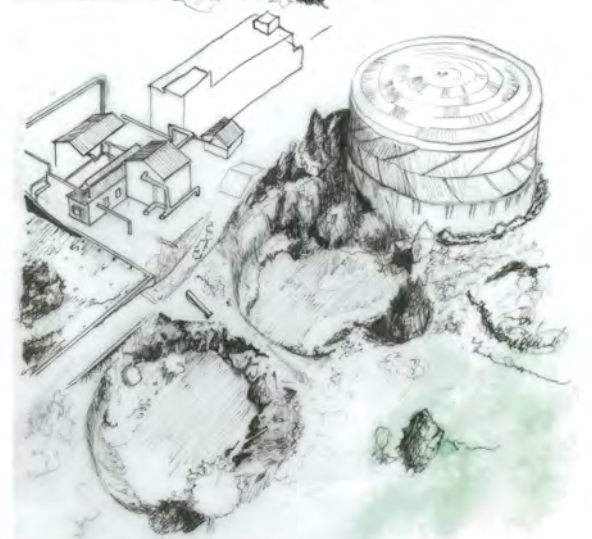
Opposite: **Figure 78** Possible interventions within gas tank holes (Author, 2017)

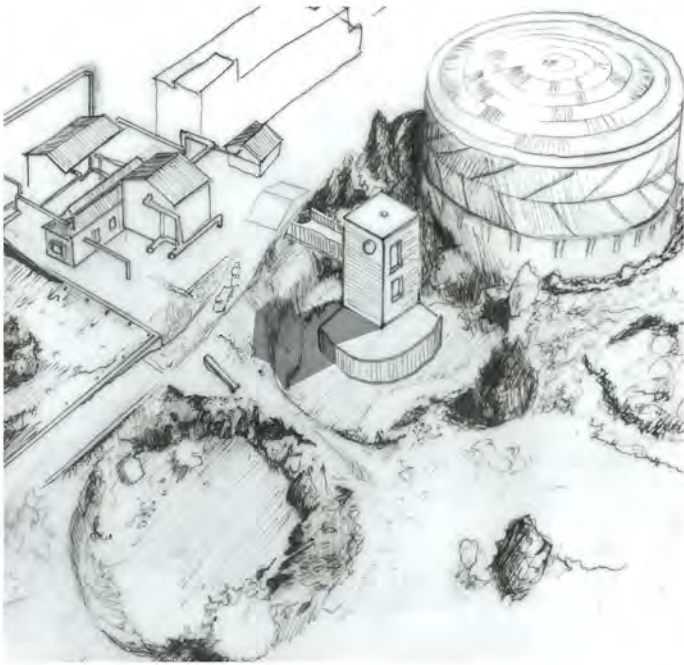


➤ The No 1 & 2 gas tank holes : Understanding place specific meaning

When using the relationship between the legacy of industry and ecology as a lens, it is quite clear why the location on which the gas tanks stood has so much meaning. As a legacy, industry has left soil pollution in certain areas, topographic disturbance and erosion. Even today, the holes have collected huge mounds of trash and rubble, probably too large or inconvenient to remove. This particular site has thus become the embodiment of the indifferent and destructive attitude that humans and, more particularly, industries have towards the natural environment.

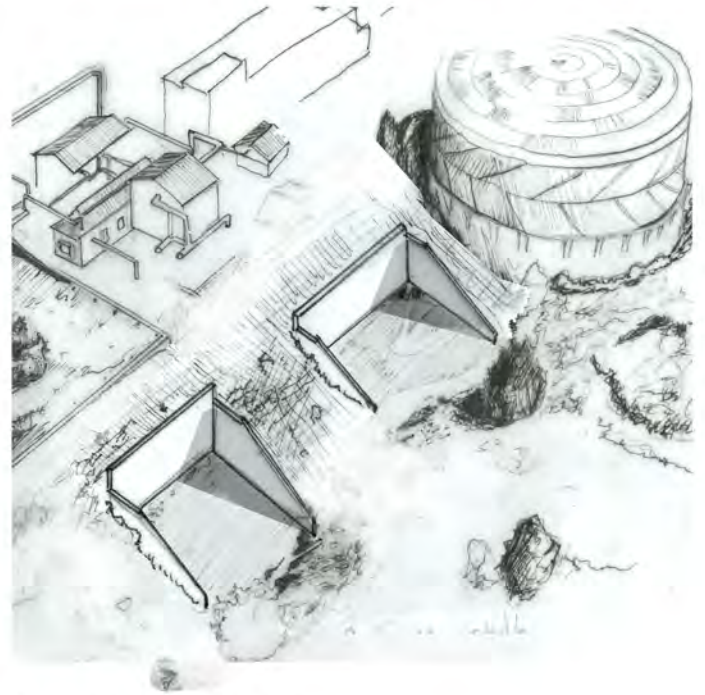
In this dissertation that aims to communicate the restitution between ecology and industrial heritage, it was decided to reverse many of the associations made with this particular site. These holes, associated with ecological death, dirt and destruction, should epitomize healing in a way that reflects back on history. This contrast, reflecting on the old industry through spatial considerations whilst housing a new industry that heals the “wounds” caused by the old industry, could be a powerful device in communicating restitution. Large circular structures usually impart a sense of impenetrability, autonomy and indifference within their surroundings. This indifference needs to be reversed by forming new associations with these holes. Associations that speak of purification- the purification of water and soil as well the welcoming gesture of accessibility instead of impenetrability.





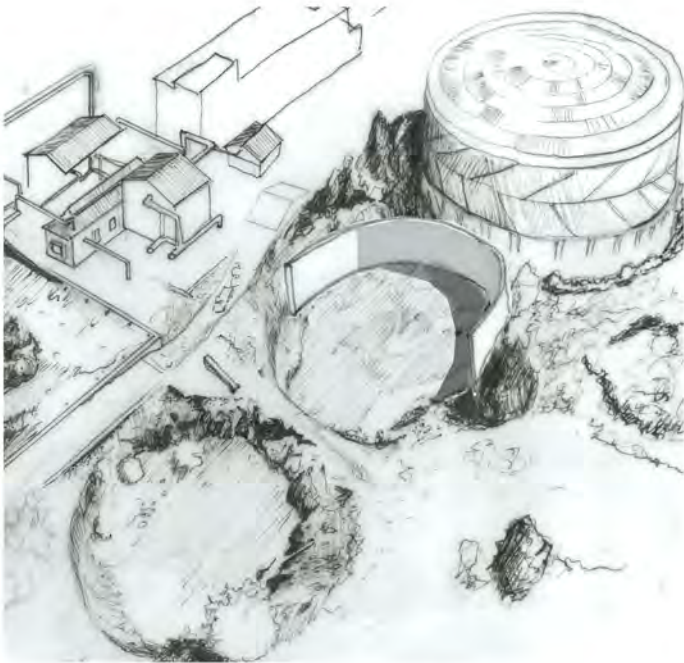
Building within the holes

As a starting point, it was considered what the consequences would be of building in the holes. It was found that the scheme would not contribute to the plaza to the south-west and that the intrusive nature of the gas tanks should rather be negated by maintaining the holes as open spaces that contribute to the park's landscape.



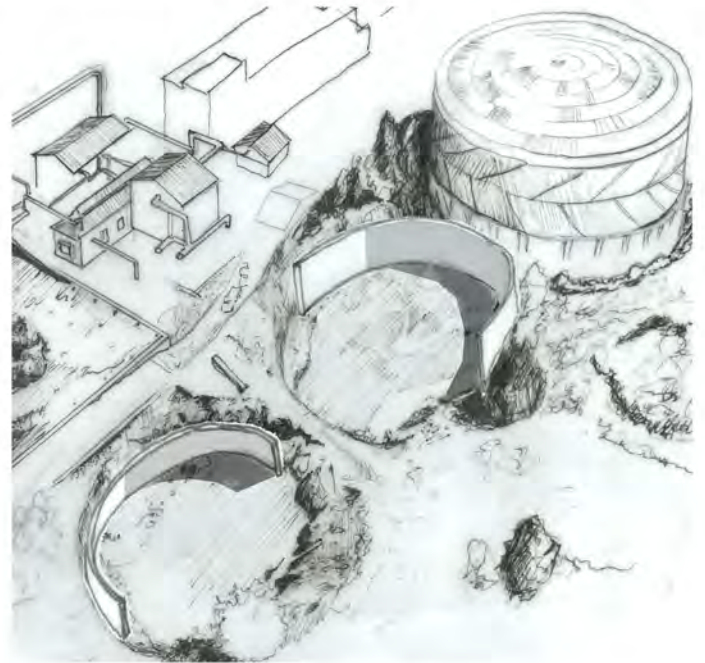
Pragmatic stabilization

If there were no regard for the structures that existed on the site beforehand, soil stabilization could easily be accomplished by providing the necessary retaining walls. This, however, goes strongly against the theory and priority of maintaining the site's history as a palimpsest that should be read in any new intervention.



Building on tank Nr.2's foundations

Utilizing the foundations of gas tank Nr 2 to facilitate the necessary remedial actions in a way that responds to the Nr 3 gas tank next to it was found to be an appropriate way to respond. Here, hole 1 is left untouched to create a progression from an undisturbed hole to a hole stabilized by intervention to the large existing structure. As explained in the previous page however, hole Nr.1 also required extensive soil stabilization and earth-moving.



Building on both tank's foundations.

This iteration aims to maintain the progression from hole 1 towards hole 3 whilst building upon the foundations in hole 1 as well by altering the scale of the retaining walls as well as the orientation of the walls. In doing so, memory of each tank is retained and water ponds can be introduced that will remain unpolluted and serve both the functions of the scheme but also serve the park landscape.

7.2

Intervention layer two- commemorate demolished structures

The second layer entails appropriate built interventions that commemorate the purification plants. The strategies regarding the No 1 & 2 gas tanks are primarily seen as remedial interventions on the topography and has therefore been addressed in Chapter 7.1

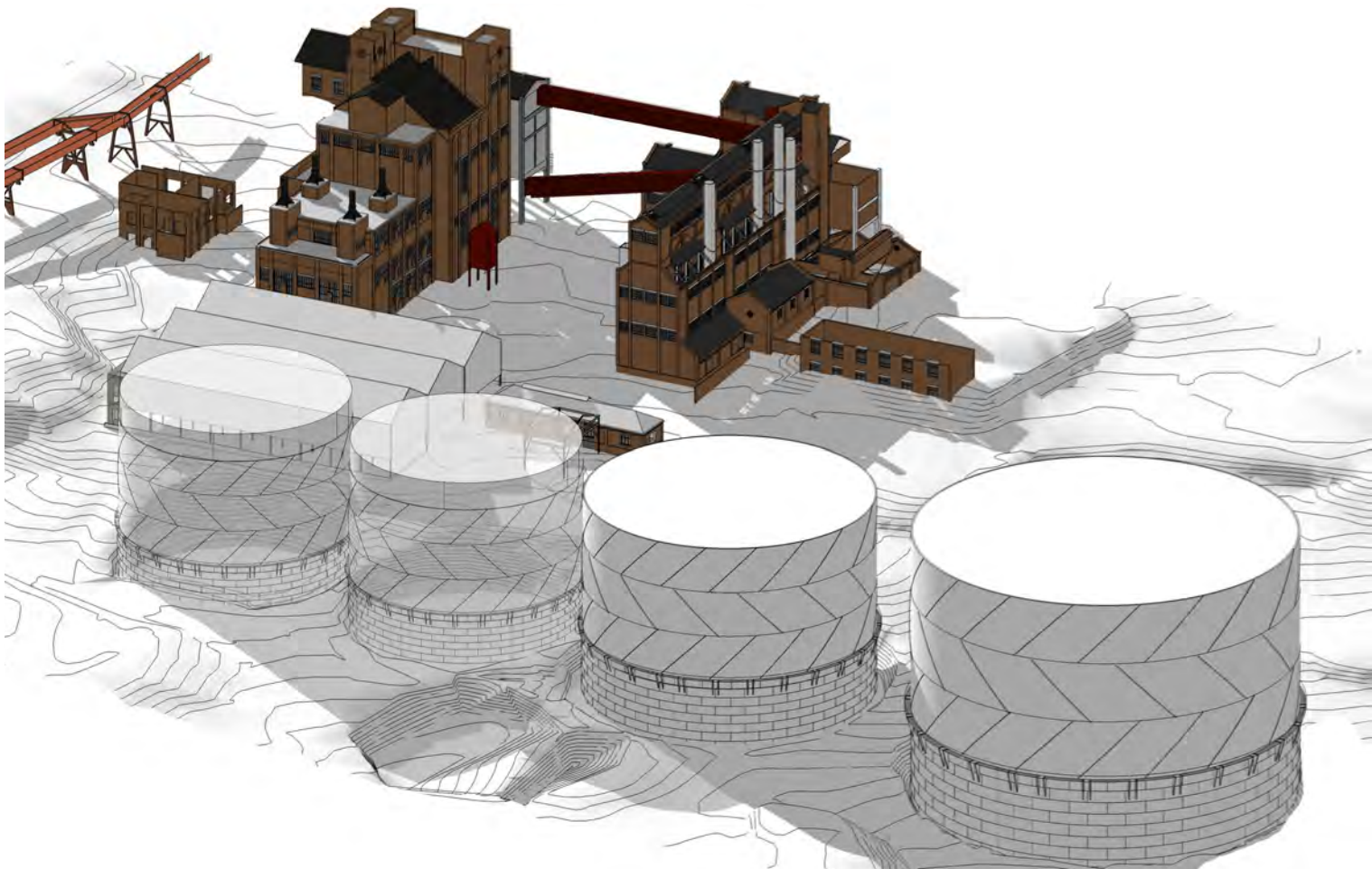


Figure 79 Demolished structures and their location (Author, 2017)

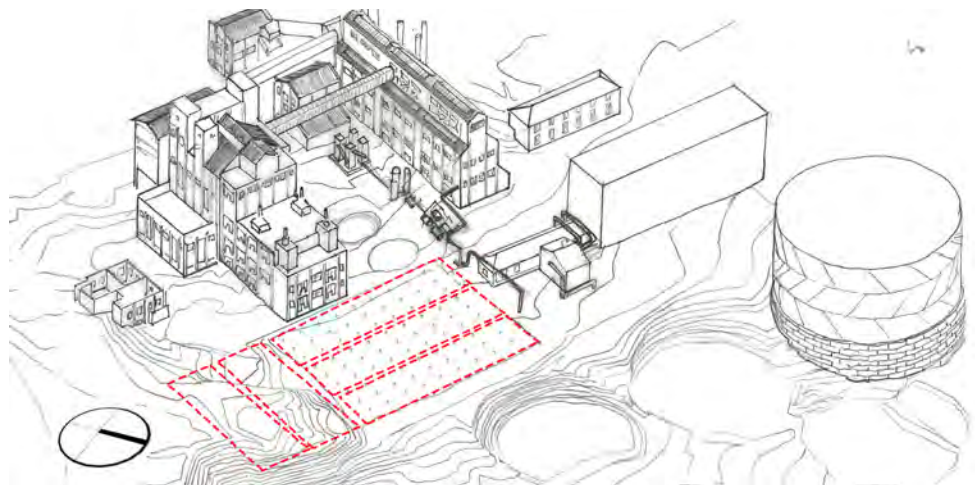


Figure 80 Sketch indicating position of five purification plants (Author, 2017)

7.2.1) The Purification Plants

Function - As mentioned before on page 19, the function of the 5 purification plants was to remove the last remaining impurity in the gas, hydrogen sulphide. This was removed in the form of solid Sulphur by mixing the gas with a small amount of air and passing it over an iron oxide catalyst supported on a suitable porous medium, such as wood shavings. This was achieved by suspending four purification boxes (one of which can be seen in Figure 84) and passing the gas through the catalyst. After an extended period of time and repeated use, the catalyst would become so hard that it would have to be removed from the boxes with a pick-Axe

Construction - The design and construction of the plant is a result of the requirements of the process of purifying gas. Since the gas would be passed over the catalyst from above before being distributed towards the distribution plant, the boxes were constructed to be suspended above the ground surface, leaving a 3,5 meter clearing below it. The floor surface was 5,7 meters off the ground, allowing shavings and catalyst to be introduced from above into the boxes (see typical cross section in Figure 82). The gas outlet would have to remain level on its way to the distribution plant and to achieve this required height, the entire structure rose 13,8 meters above the ground, supported by 304x150mm steel I sections spaced at 5,3 meters apart through the length of the structure. To achieve a width of 13 meters, the shed was conceived as a series of portal frames and the entire structure was clad in corrugated iron sheeting. For lateral stability, cross-bracing was used at every second column bay as can be seen in Figure 81.

Notable features - The portal frame profile of the shed-like structure and the structural system with its large iconic cross bracing expressed on the facade

Present day condition - After demolitions in the 1990s the only remains are seen in Figure 83 where corrosion of the steel I sections of the northern-most plant have caused the concrete footings cast around the sections to spall. The foundations of the two plants in front of Retort No 2 have been covered in rubble that can be removed whilst the easternmost two plants have been completely covered in meters of soil for reasons unknown.

Statement of historic significance - The purification plants were not only uniquely suited to their individual function within the gas production process, but were also shaped by their position within the entire ensemble of gas production. The site's topography and the surrounding buildings dictated the levels of the gas inputs and outputs that had to be accommodated by this structure, leading to its unique suspended design and significant height. It served as the last stage before gas could be used and therefore within the entire industrial sequence, the plants have to remain legible in order to the Gasworks narrative of gas production to remain legible.

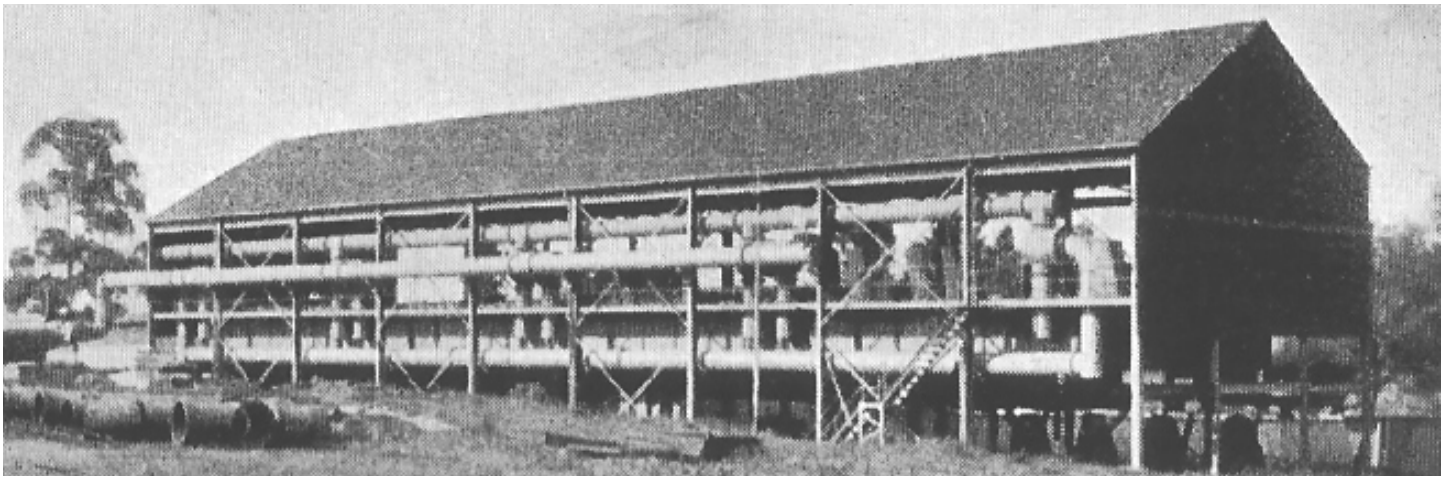


Figure 81 Dry purification plant_1929 (Tsica archives, 2017)

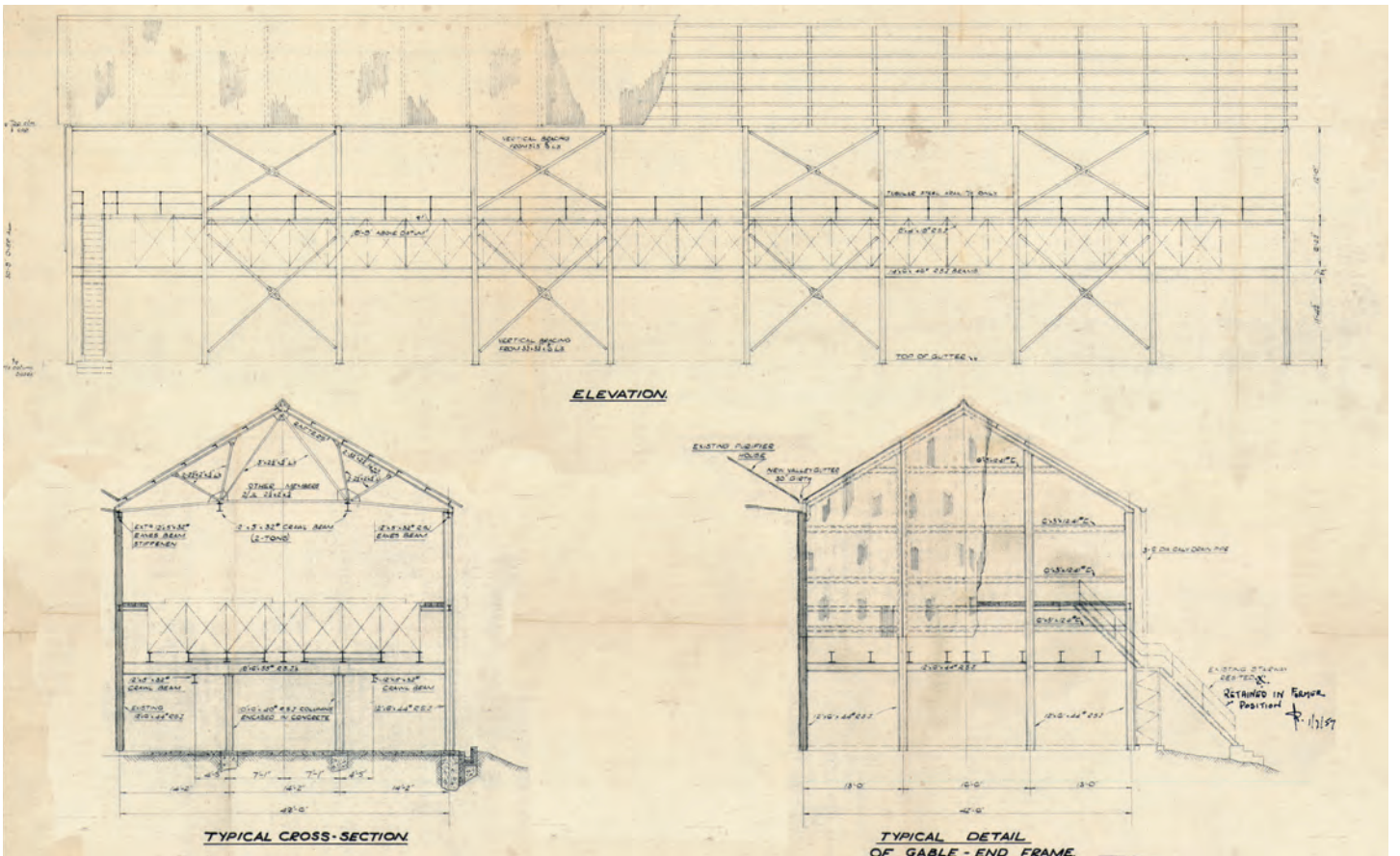


Figure 82 Construction drawings for purification plant (Tsica archives, 2017)



Figure 83 Column stubs (Photograph by Author, 2017)



Figure 84 Purification box inside plant (Tsica archives, 2017)

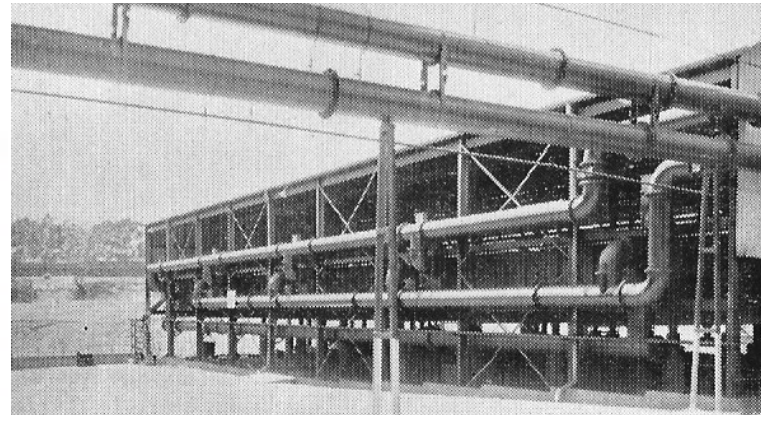
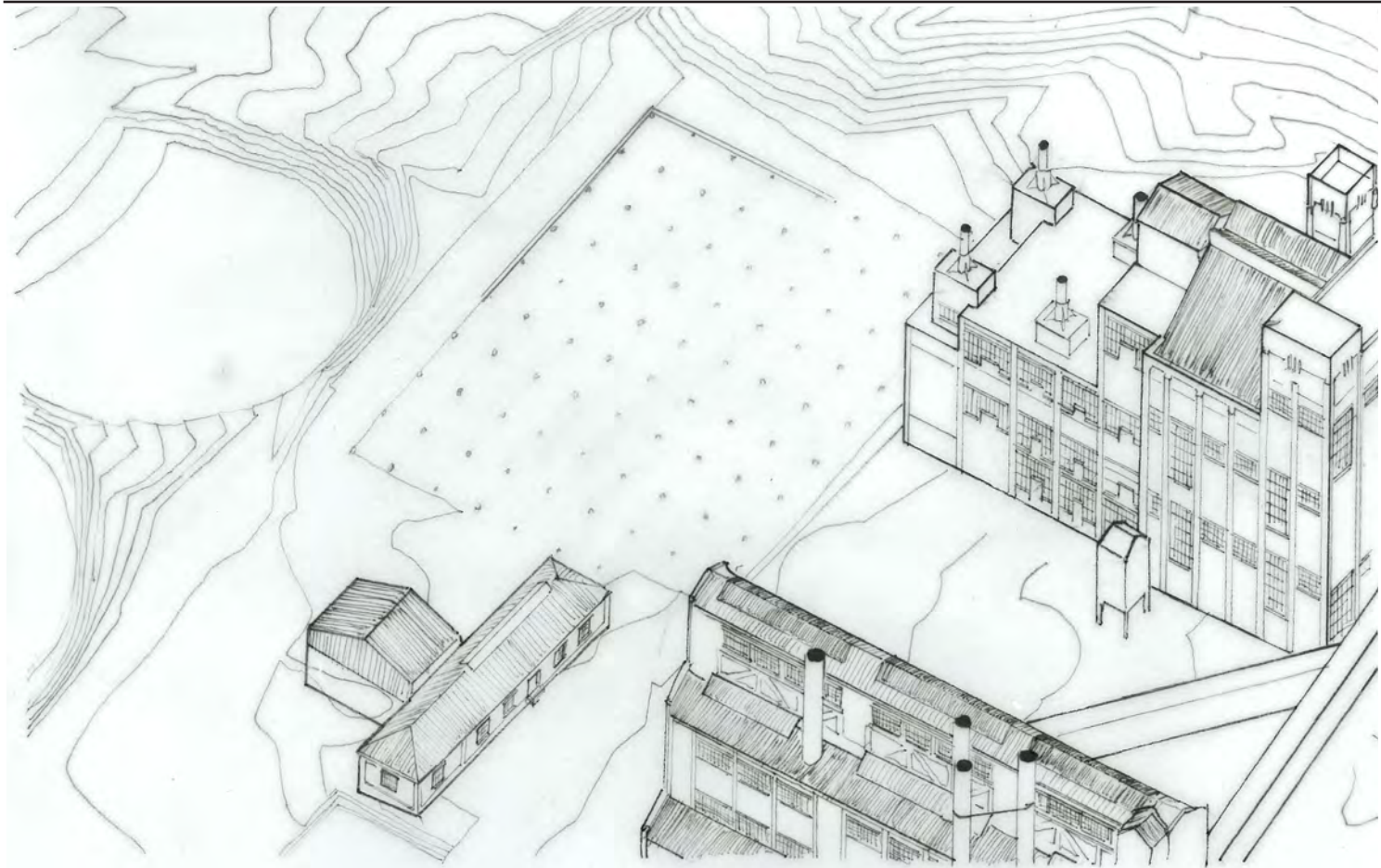
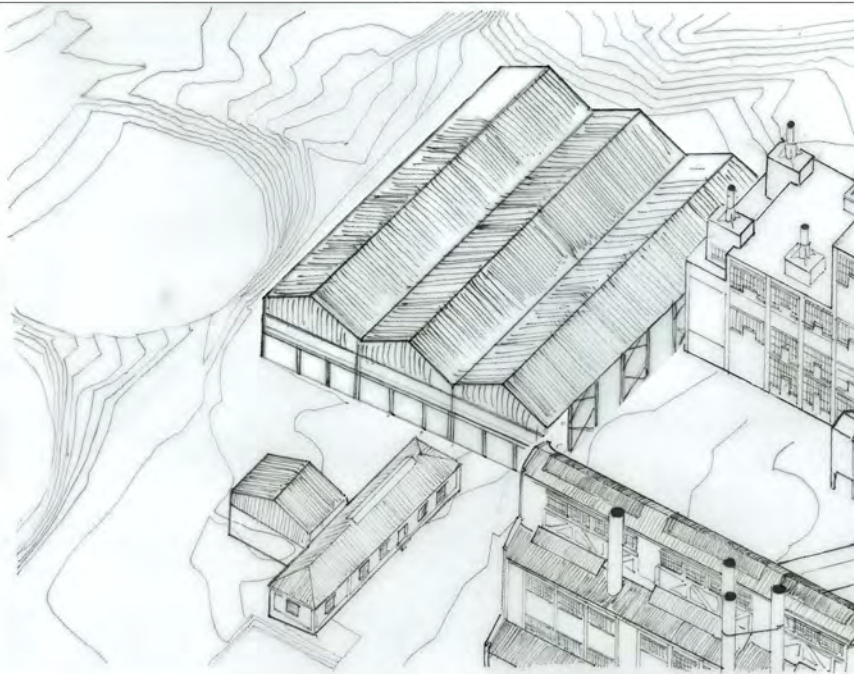


Figure 85 Gas plant_Cottesloe_ 1950_dry purification plant (Tsica archives, 2017)

7.2.2) Appropriate Commemoration



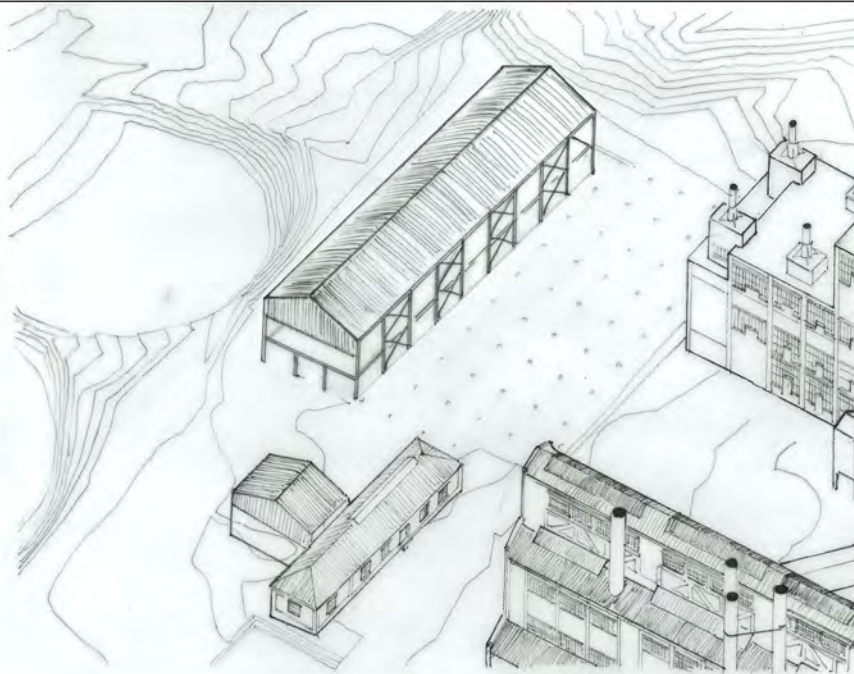
As mentioned in the chapter on theoretical approaches, total reconstruction is not considered an adequate way of commemorating a demolished structure, but rather that buildings should be translated into their current contexts. An adequate way would be to identify features that should endure this translation into the present age and maintain some memory of those features as a palimpsest. These could then be read in conjunction with contemporary design interventions. However, in the pursuit of an adequate design response the idea of reconstruction served as a starting point towards more deconstructed interpretations in a process of diagrammatic sketch designs.



Total reconstruction

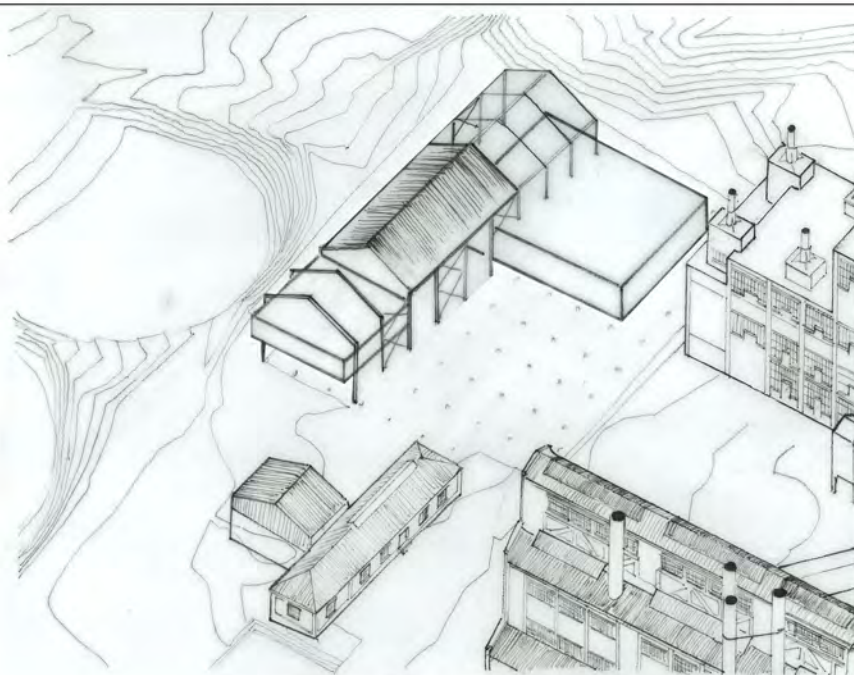
The reconstruction of all three plants were found to be an inadequate response for the following reasons:

- 1) Contradiction to theory and adequate "translation"
- 2) Scale too vast to accommodate the functions of the project's programme
- 3) The disruption of significant public space.



Reconstruction of one

With the first design iteration it was found that the reconstruction of even only one of the purification plants would be inappropriate due to its scale. Commemorating the shed profile in an alternative way than rebuilding the 14m high structure was found to be an avenue worth exploring.



Structure vs form

Iteration two entailed rebuilding the structure as it was originally, but forming masses that define open, closed, public and private spaces that have an interplay with the structural frame. This iteration proved to employ no interrogation of the actual frame itself but still entailed reconstruction.

Maintaining three profiles

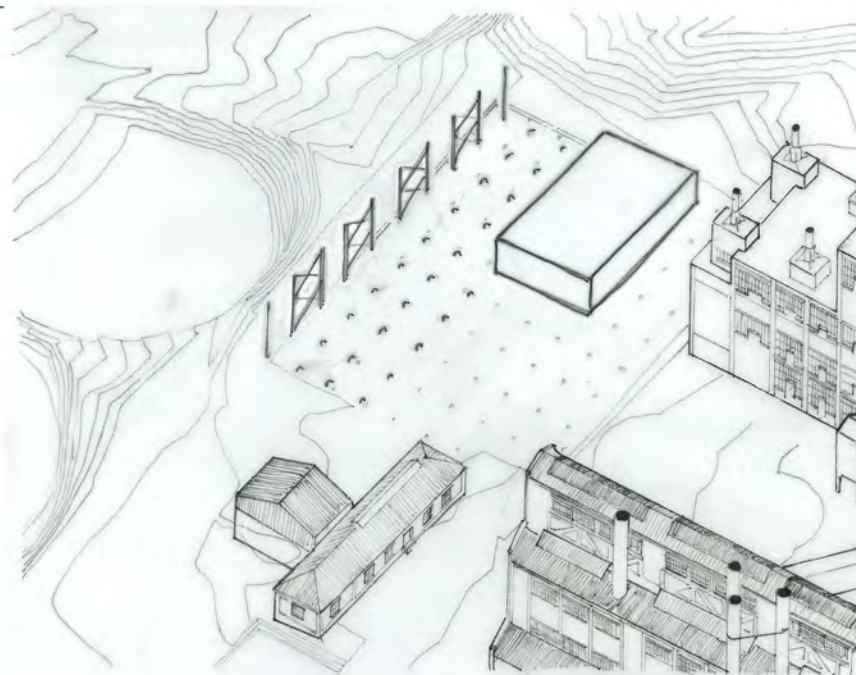
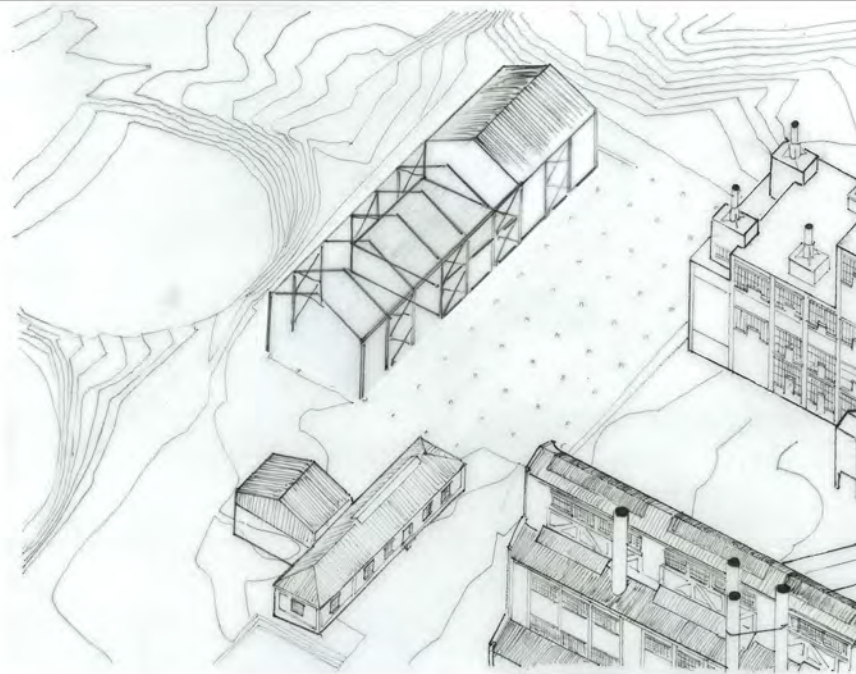
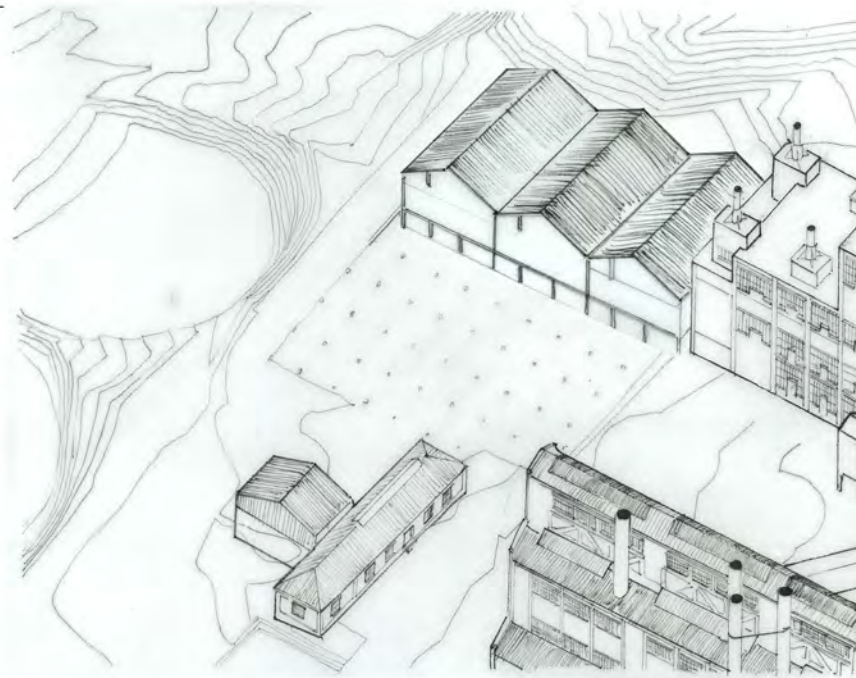
This design exploration was found to not contribute to or define the public space it sits in as well as it could. Also, with an outdoor market space planned by a different scheme to the right of Retort 2, this layout posed some obstacles to a continuous public space.

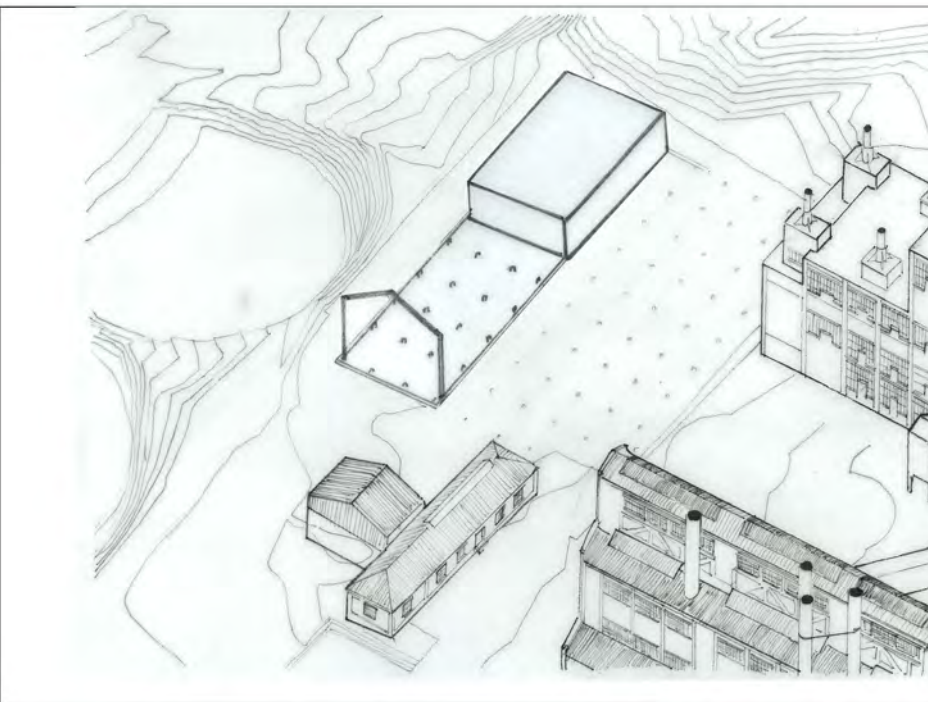
Building along the frame

With this iteration it was attempted to resolve the commemoration of the full length of the original footprint whilst maintaining the westernmost space as open and public. This was done by rebuilding the frame and constructing spaces that become more enclosed and private as it moved along the length of the footprint. Rebuilding all the frames was found to restrict freedom in the design process and therefore ended with this iteration.

Separate mass and footprint

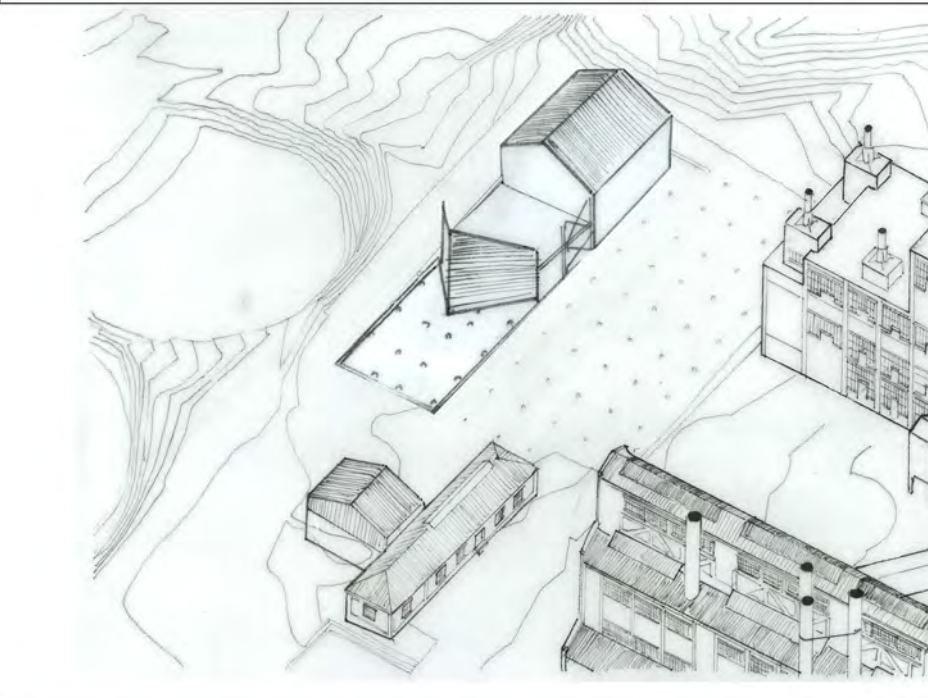
Iteration five entailed maintaining the footprint of plant no 5 as an open space with a new mass adjacent to it. Although this layout offered great potential in terms of public space, it didn't read as a destination at the end of the significant viewpoint and approach line and posed a disconnection with building no 2 proposed within hole no. 2





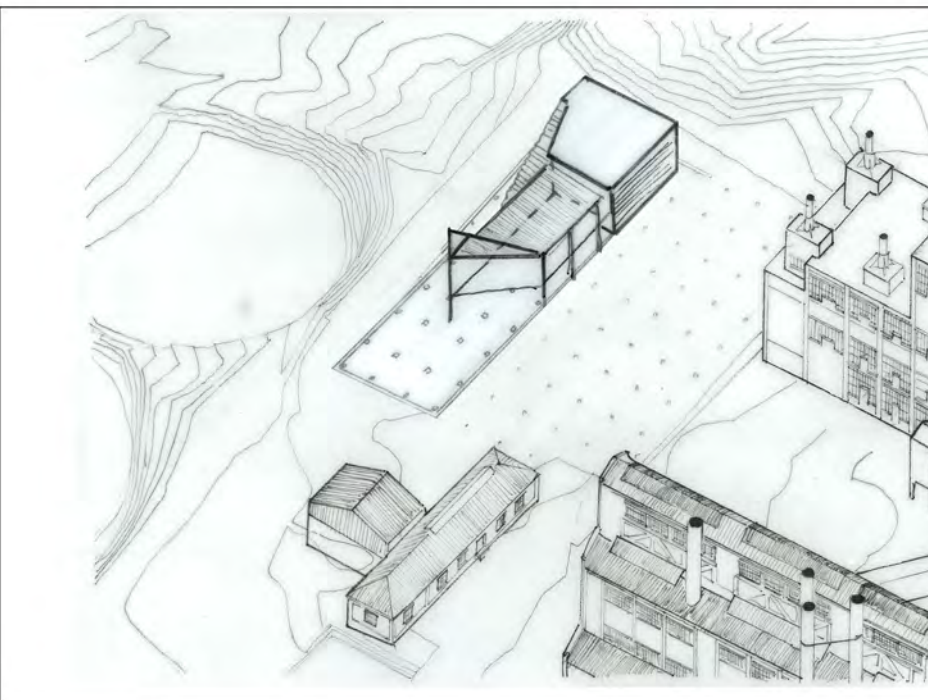
The shed profile as folly

Iteration six entailed the separation of open and closed space along the building footprint and saw the shed profile as an element that needn't have any connection with the building, but that it could be a mere folly. This seemed an inappropriate disconnection between commemoration and contemporary construction since the profile would remain an object isolated from a functional design resolution.



Breaking the orthogonal grid

Iteration six explored the idea of merely maintaining the appearance of the shed profile as one approaches the scheme, whilst not building on the actual foundations. This would be adequate since a clear distinction between the past condition and present condition could be made through changes in geometry, whilst still making reference to earlier form.



"Climbing" along the footprint.-

Iteration seven offered more recreational and public opportunities in the design by viewing the building mass as an entity that grows and leads to a accessible vantage point at the top. The front end of the plant footprint was envisioned here also as a water park where the stub columns could be translated into contemporary use as holes in the water surface. The shed profile could be maintained by utilizing half of the portal frame shape as support for a more tectonic structure.-

7.3

Intervention layer three - formal heritage responses

The third layer entails the built interventions in their formal qualities such as placement, materiality and scale.

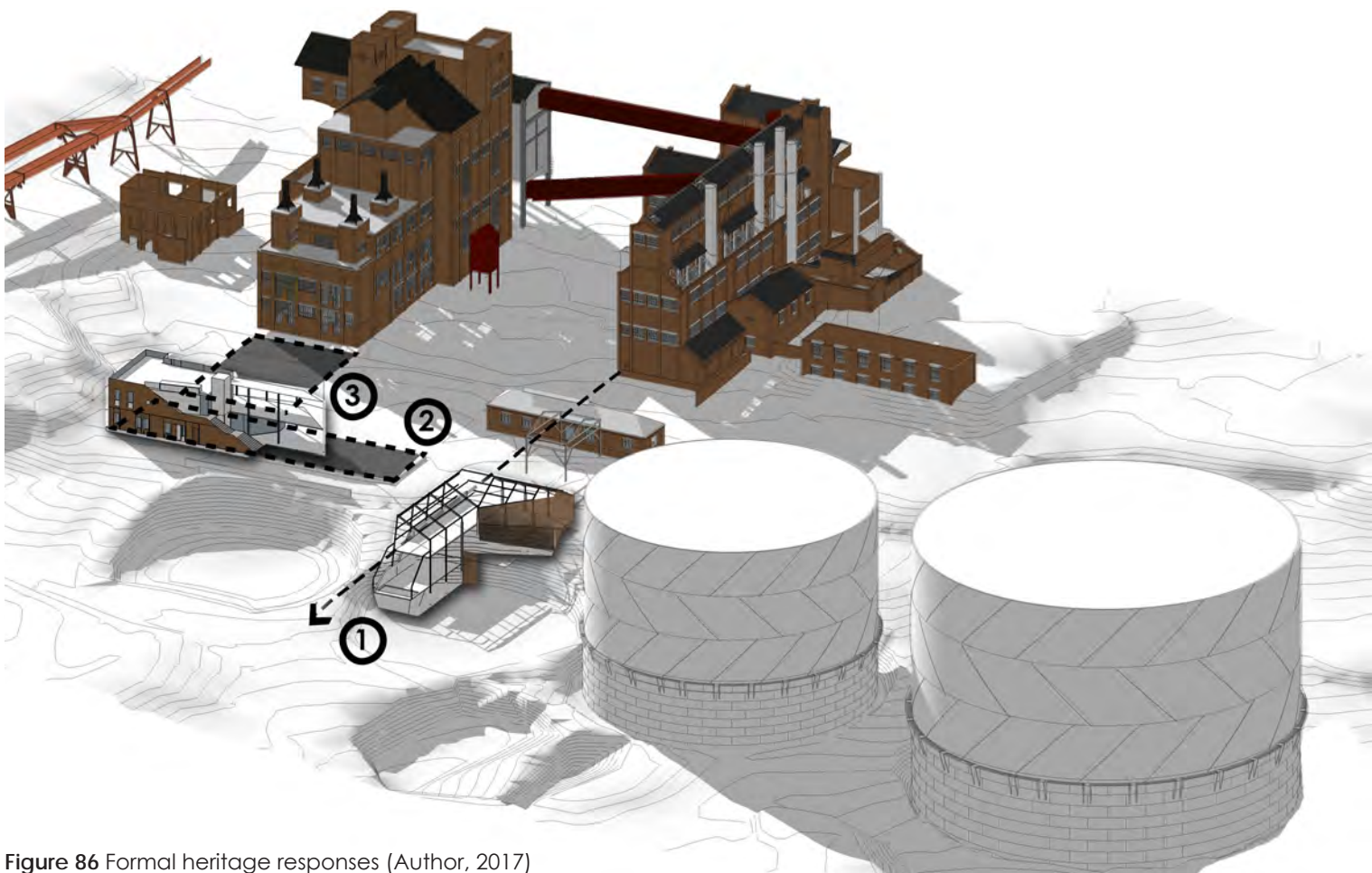


Figure 86 Formal heritage responses (Author, 2017)

Place-based design interventions & opportunities

1) Extension of industrial heritage narrative

In a formal sense, building no 2 derives its placement, roof and verticality to its alignment with Retort No. 1. Its construction detailing will also stem from Retort 1 as will be explored in the next chapter.

2) Place-making between new and old structures.

Framing and activating spaces seek to restore coherence between old and new built fabric and thus create well defined public spaces in between.

3) Respond to Retort No. 2

Formally, building no 1 derives its horizontality, materiality and construction from its location in front of Retort No 2's North-Eastern facade.

Below:

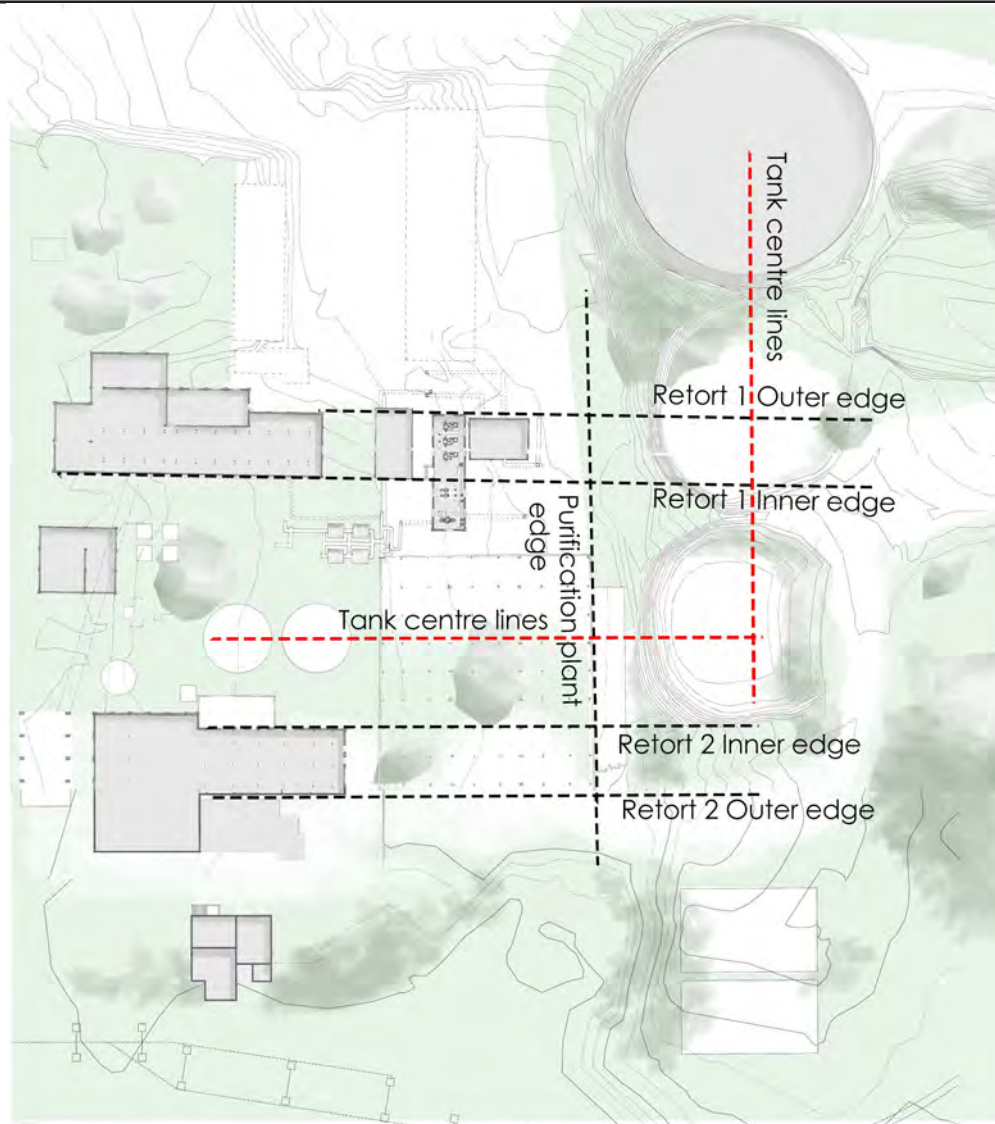
Figure 87 Identifying order (Author, 2017)

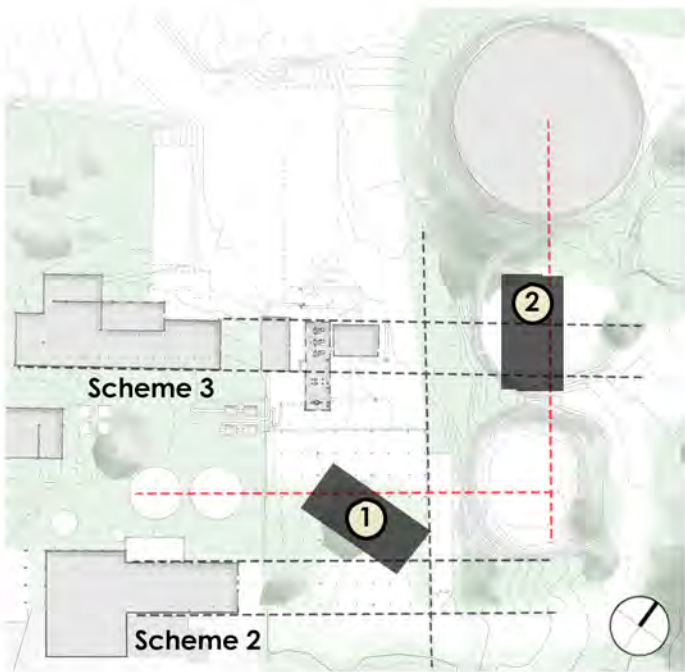
Right: Figure 88 Design explorations as response (Author, 2017)

7.3.1) Overall intervention area

The built fabric on the intervention area within the Johannesburg Gas Works site was laid out according to the process of producing gas from coal in a manner that utilized the topography. This ordering system, legible on the site, provides a set of guides that any new architectural intervention could pay respect to. The diagram on the right identifies these guides and the diagrams on the right note possible responses to these guides and the effects thereof.

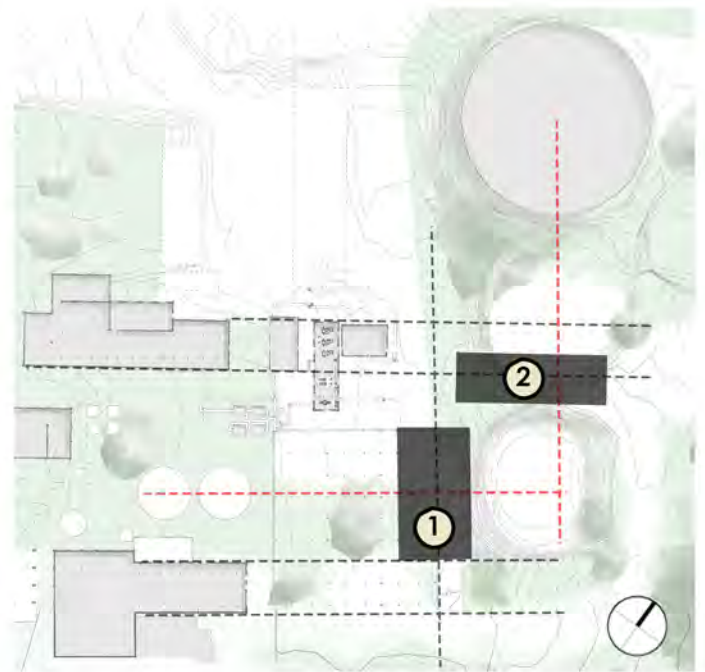
It was decided early on in the design process to design the scheme as two entities, each entity fulfilling its own distinct role. The first entity, responding to a linear alignment of significant industrial heritage to the south-west would represent a new industry and extend that linear alignment towards the park. The second entity would facilitate the public's experience of this industry and form part of an open plaza proposed by this scheme as well as two other schemes.





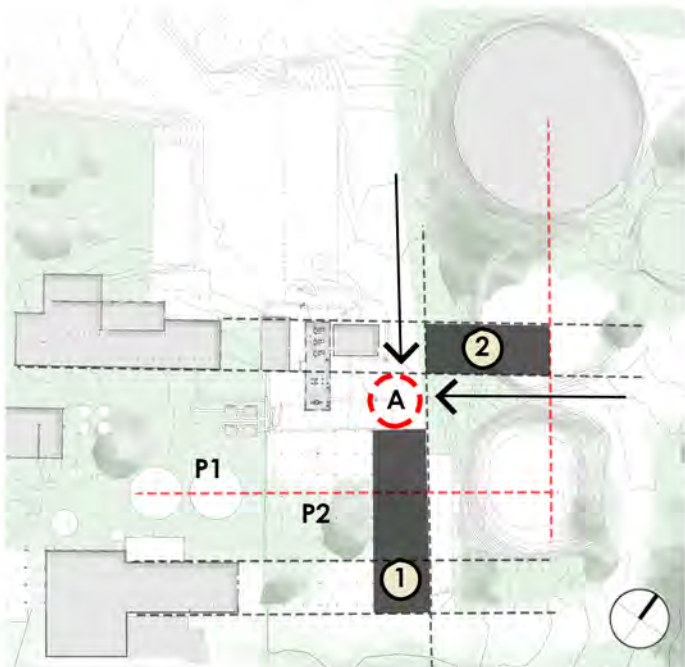
Non-alignment (north-orientation)

Building 1's placement within the purification plant plaza closes possible open space between scheme 1 and 2. This orientation would serve as an intentional disruption and would communicate a disregard of heritage fabric. Building 2's location within hole no. 2 would negate any possibility of interaction with the public realm to the west.



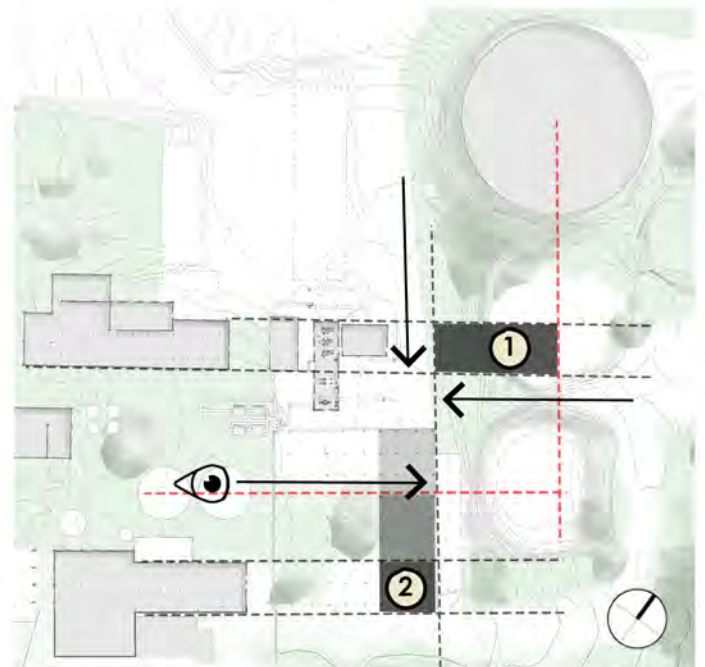
Alignment with structures as priority

Placing structures directly upon alignment axes has 2 undesired consequences. Building 2's location would block linear access between the park to the east and the plaza to the west. Building 1's location purposefully negates the grid upon which it is built and its distance from scheme 1&2 could make a cohesive plaza between these three schemes less successful.



Alignment and reconstruction

Rebuilding the entire footprint of the easternmost purification plant was feared to create a separation between plaza 2 (P2) to the west and the arrival space (A) from the park and the north. A visual connection from Plaza 1 towards the park to the East would also be blocked. Building 2 aligns itself to Retort No. 1's inner edge and opens the possibility of access from the park. Aligning building 1 with retort 2 would negate the rectangular footprints of the plants.



Alignment, alternate reconstruction and openness

This iteration of the layout to the left still utilizes the full footprint of the easternmost purification plant but the footprint becomes a building to the south and contributes to an open recreational area to the north whilst keeping space open to the west in order to design a coherent plaza between the three schemes. The difference in programs between the two buildings allows this distance as long as landscape binds them together as one intervention

7.4 Intervention layer four - programmatic responses

The fourth layer responds to the programme as well as public components. It defines the nature of spaces created between built interventions and seeks to create more definition of public space through programme.

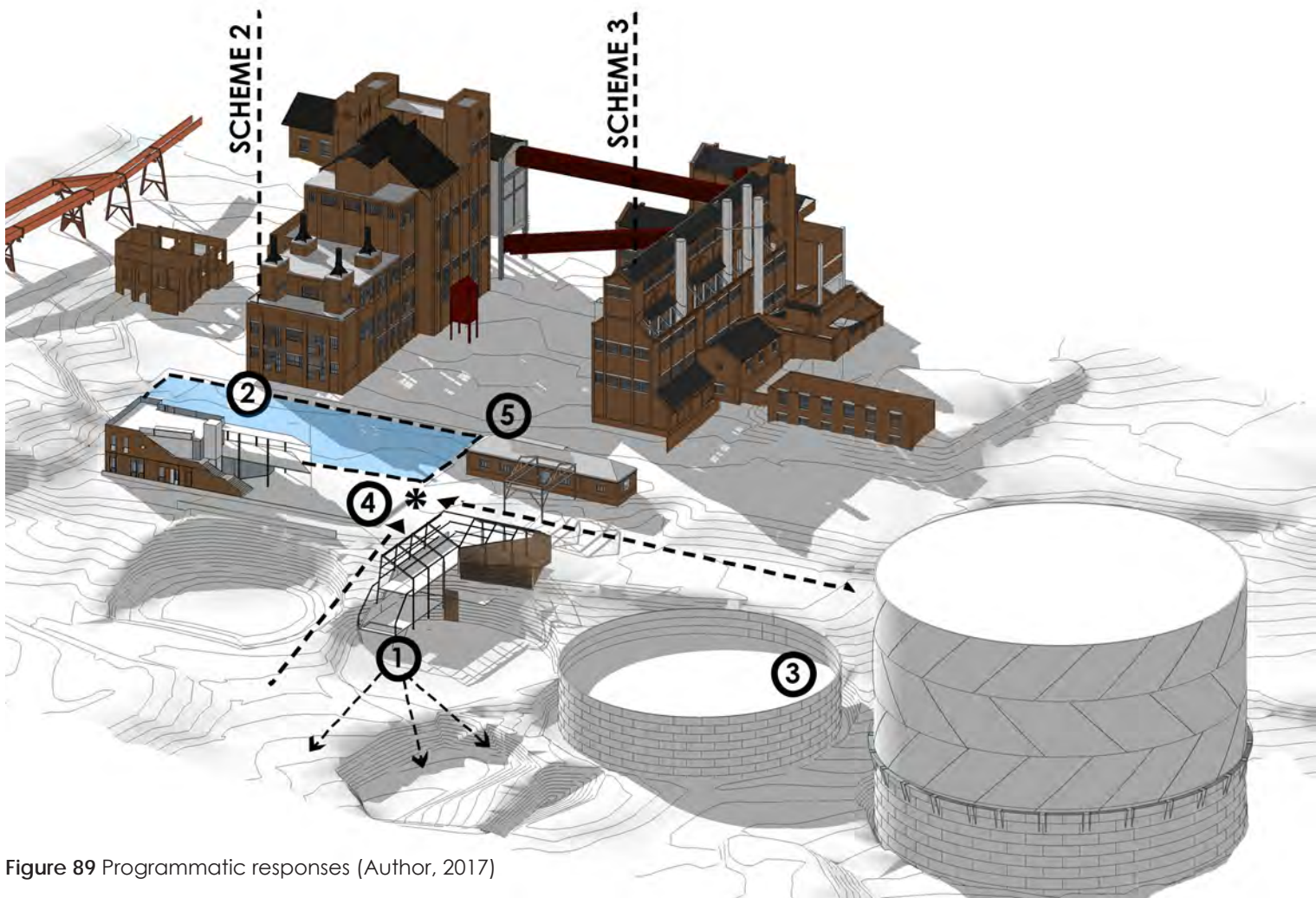


Figure 89 Programmatic responses (Author, 2017)

Place-based design interventions & opportunities

1) Active environmental remedial action

By introducing the production of fish feed for aquaculture in building No 2 which has compost as a by-product, the terrain could continually benefit from successive soil purification. Therefore, its placement within the linear heritage sequence makes it the communicator of industrial progress that is read as the next chapter within industrial heritage.

2) The definition and activation of public space

A priority in terms of public space creation was the creation of an outdoor fish market area that would be in close proximity to the market area of scheme 2's textile market (see illustration).

3) An industrial giant's surrender to ecology

By removing the steel casing of gas tank No 3, the foundation basin can be filled by excavated soil following the construction of all four schemes and be made accessible to the public. Since compost is produced in close proximity, an outdoor nursery component to the scheme as well as open air rainwater storage will transform this industrial icon into a valuable contribution to the park landscape with noteworthy vistas of the park and the rest of the site.

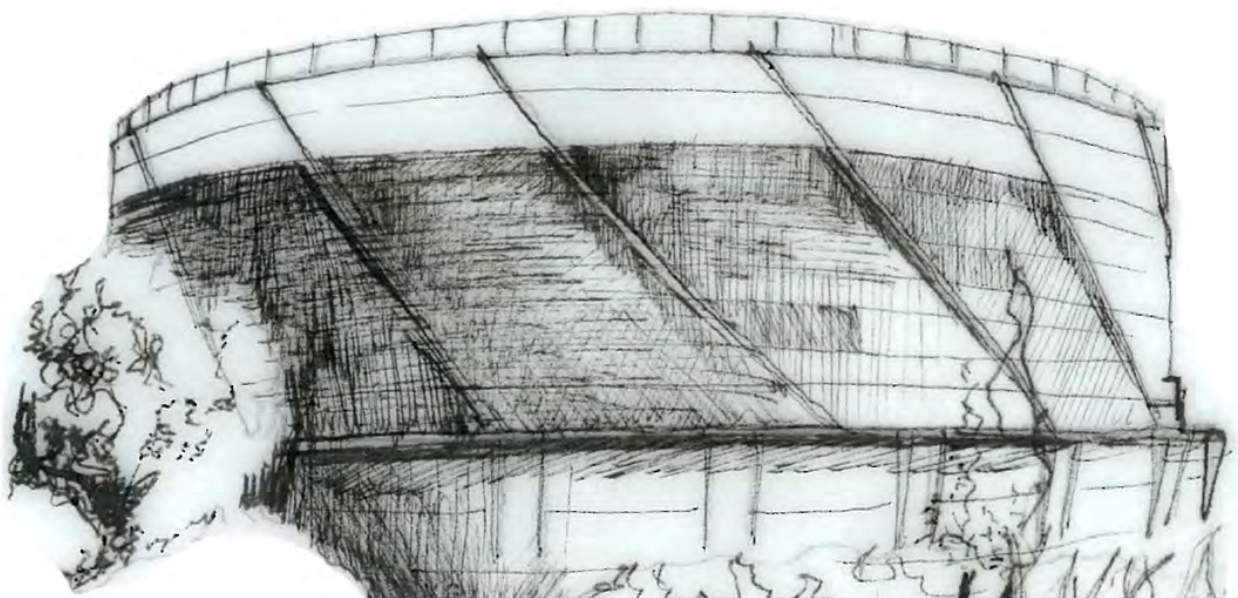
4) Recreation and the presence of water

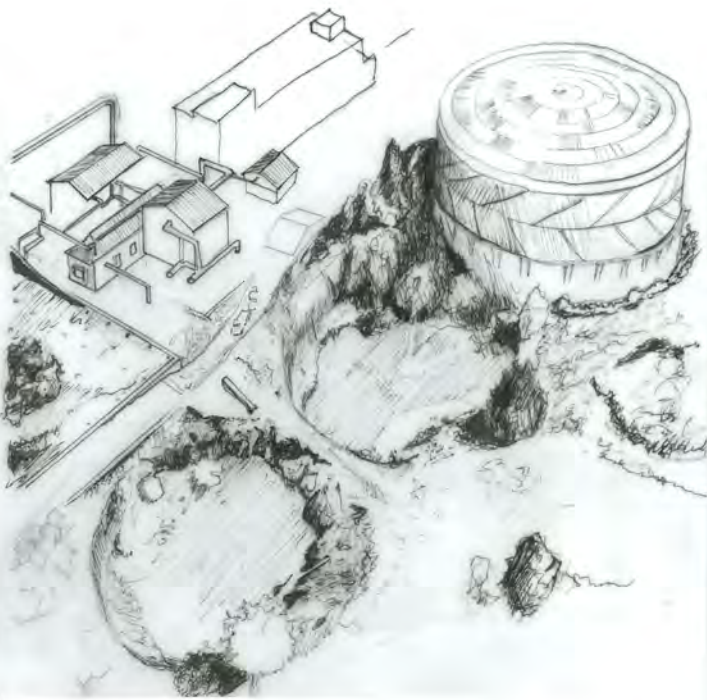
Re-used piping taken from the basement of the distribution plant are here transformed into water-spewing features within the water park. The water park follows the envelope of the purification plant and holes within the water surface occur where columns used to be located prior to demolition. The goal is to have the water park in close proximity to aquaculture breeding tanks so that this intentional proximity can meet any user when the scheme is entered from either the park or from the north-west.

5) The distribution plant

The distribution plant will accommodate a fish market and museum in its interior.

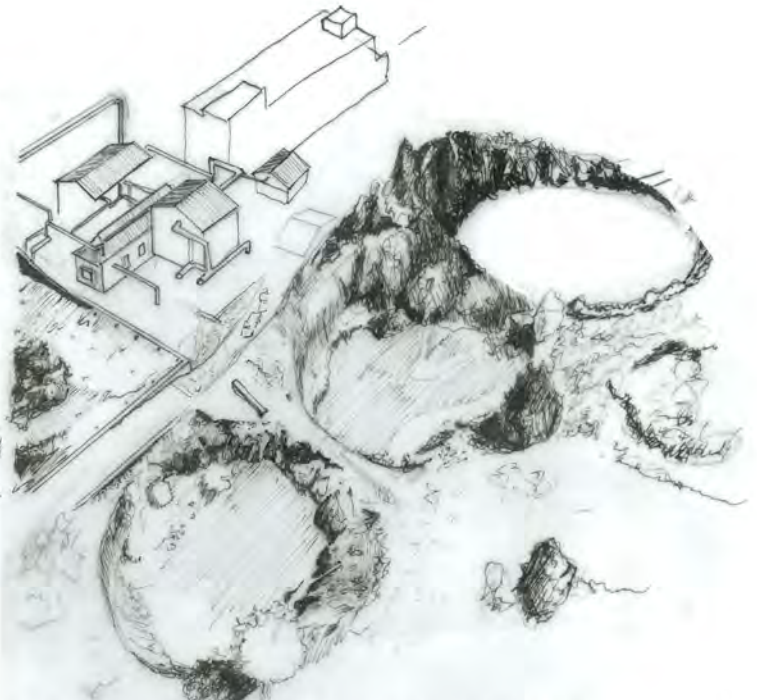
7.4.1) No 3 Gas tank





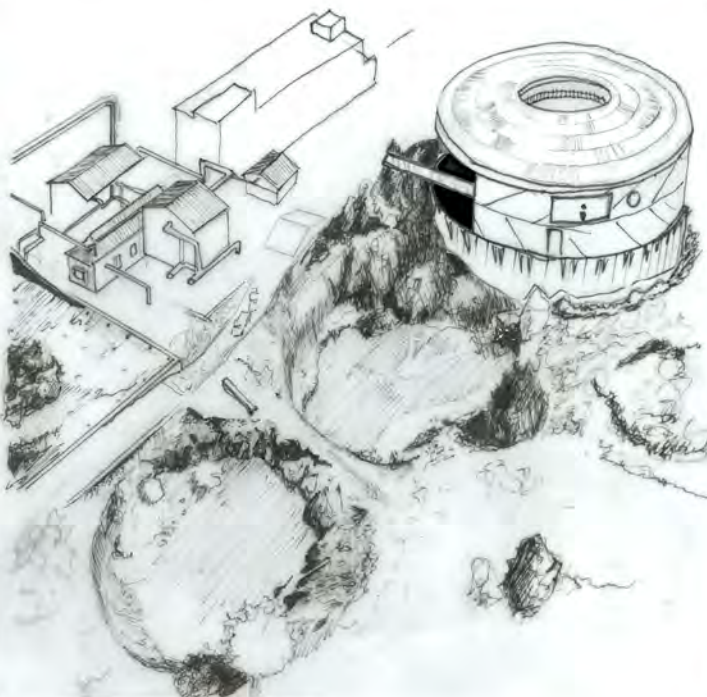
Leave as is

Since the tank needn't be used by Egoli gas anymore, the structure can be utilized for its vast scale and stability. There is a potency in reading the tank as part of the scheme since the scheme would then include newly built architecture as well as a repurposed structure as part of the same scheme.



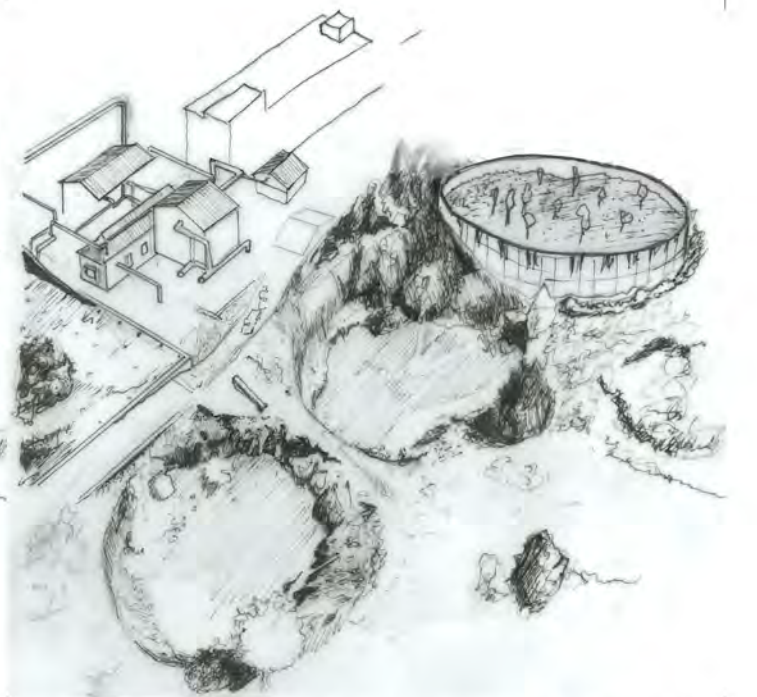
Remove entire structure completely

If the entire structure (foundation and steel cylinders) is removed, the same problem of soil stabilization would be caused that is being resolved in the other two holes. The existing circular foundation still serves its purpose as retaining wall and therefore the structure should not be removed completely.



Utilize interior space

After a thorough investigation it was found that the base of the interior should be about 3m below the surrounding ground level. This coupled with the construction method of the envelope (steel sheets welded to diagonal steel sections) made repurposing less effective than any new build. The placement of functions within this structure was also found to be too far from any coherent public space such as the plaza.



Utilize foundation as park/program extension

The most appropriate solution was found to be keeping the retaining wall but removing the steel cylinder above it. The foundation can be used as a basin for polluted soil, demolition debris from site alterations and the raised surface could be used as an extension of the park landscape and an open-air plant nursery. This would be a powerful statement of how industrial heritage fabric can be used for ecological functions.

7.5 Design explorations

As seen in Figure 90 the design iterations started with a strategy for the comparison between the undisturbed pre-industrial ecological condition and the post-industrial condition: this was realized through the construction of green roof construction over hole no. 1 that would simulate the topography as it was before disturbance. This surface could then serve as an extension of the park. It was abandoned for its non-natural means, its forced approach and also for the quality and scale of the space below the surface.

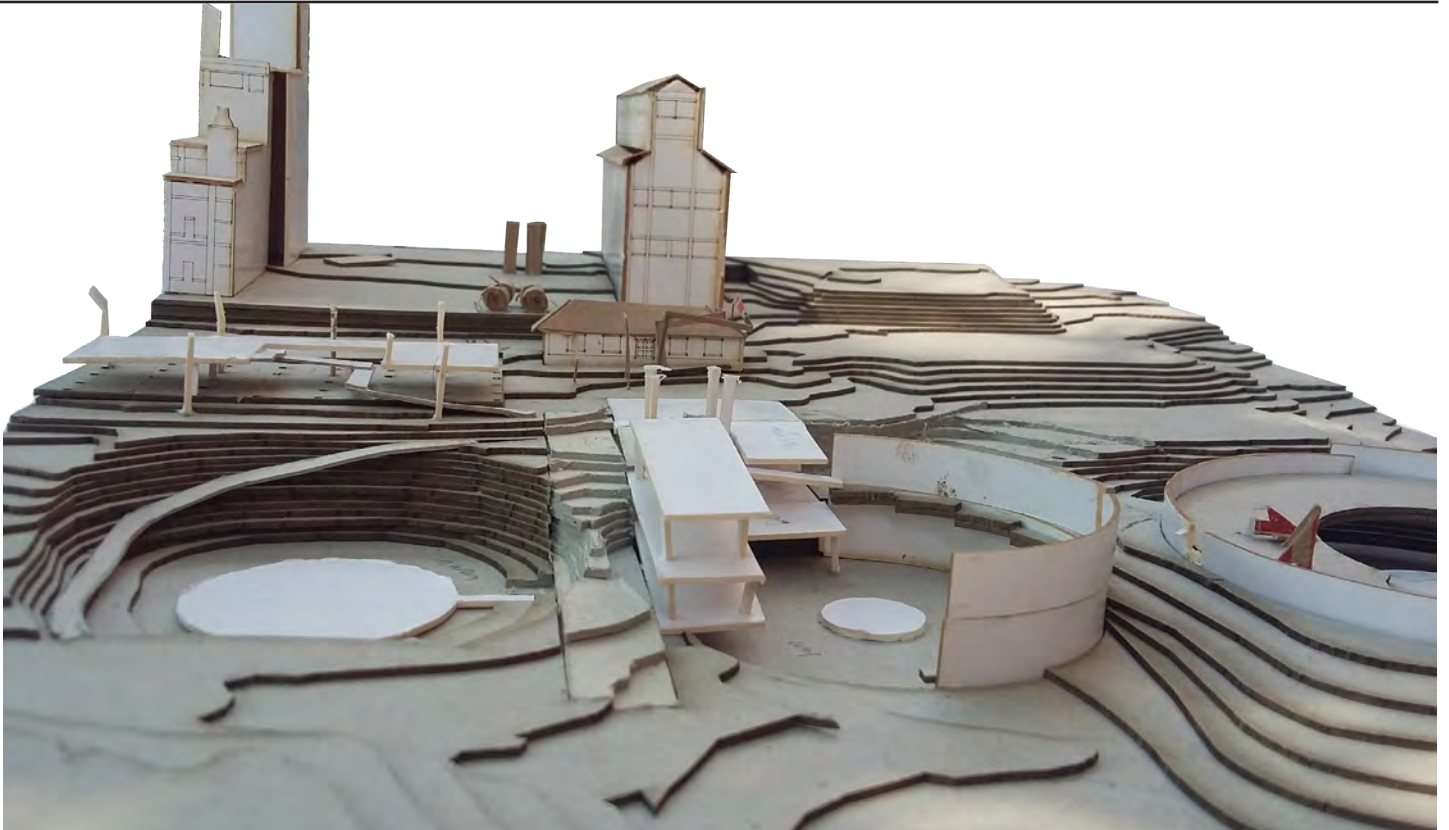
The scheme also entailed a spatial progression and hierarchy that followed an axis starting at hole 1 and reaching a climax at a re-appropriated gas tank Nr3. The tank would be utilized to its full extent, with private functions hidden within the above-ground foundation and more public spaces within the tank's higher levels, overlooking the park. As mentioned in chapter 6, it was found that re-appropriation of this structure poses various construction challenges and would isolate important spaces from any contribution to a public plaza to the south-west.



In Figure 91, a more formal response was sought for the restitution of ecology and industry. In this iteration, rectilinear forms derived from the heritage fabric would interact with circular forms to create space. The binding element would be similar tower-like circulation spaces in each hole. This design proposed a linear stair connecting the park to the heritage square. This iteration was found to overly formal, with no consideration for industrial remnants on site or adequate remedial actions for soil pollution.

Left: **Figure 90** Model exploration 1: Rebuilt topography as means of commemoration and reflection
Opposite bottom: **Figure 91** Model exploration 2: Interplay between rectilinear and circular form
Below: **Figure 92** Model exploration 3: Structure, scale, placement and the nature of the stair.

➤ Two entities with two natures and the connection between park and square



7.5.1) Design iteration 1

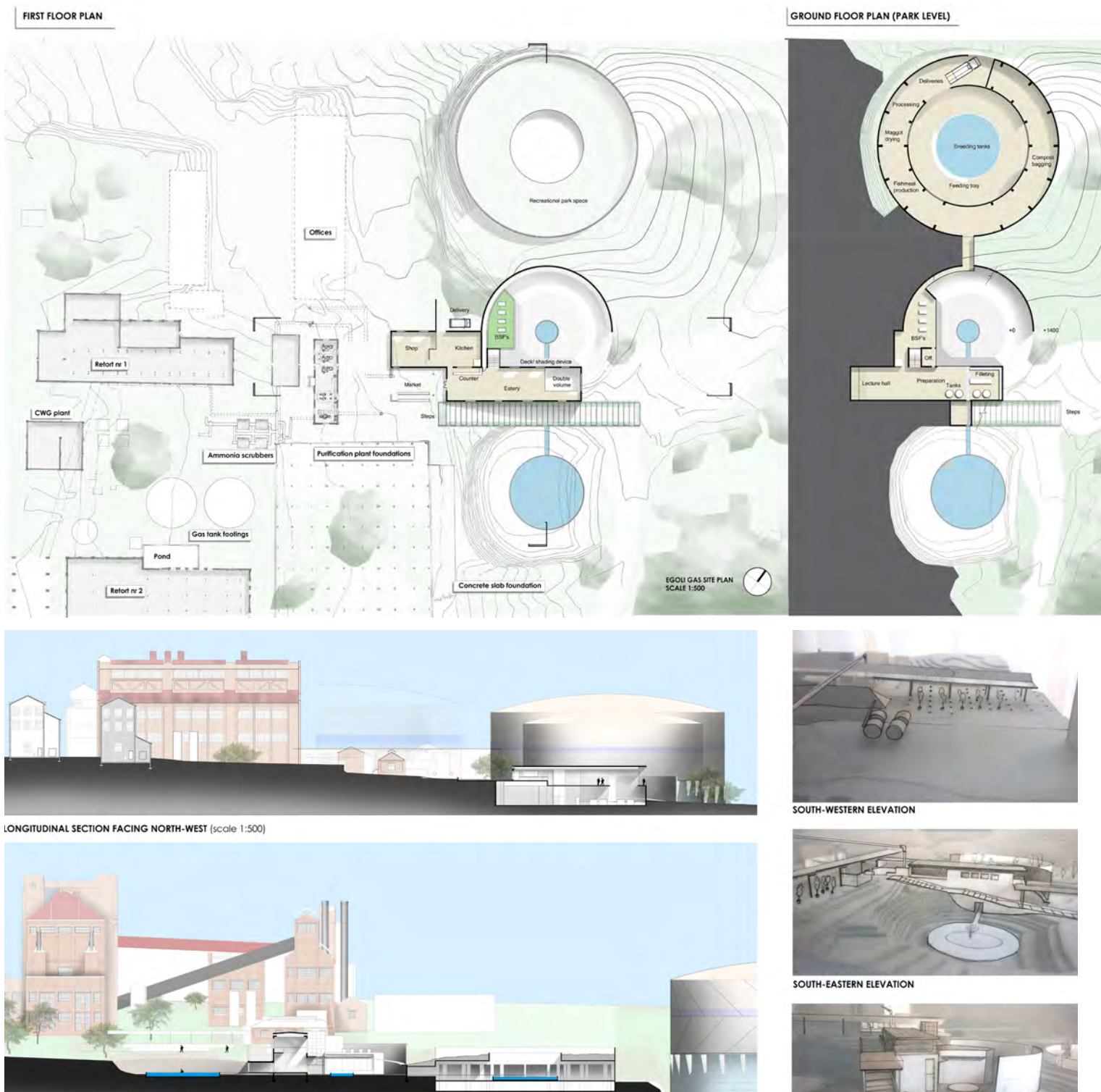


Figure 93 Design iteration one with re-appropriated gas tank no.3 (Author, 2017)

Design iteration 1 entailed the construction of a new building within hole no. 2 and re-appropriating gas tank no. 3 for more intensive industrial purposes. In this design, hole Nr1 and the purification plant plaza are left as they are as places of interest that can be visited. After further development, it was found that re-appropriation was unfeasible since the internal ground level of the tank would be about three meters below the soil. The foundation walls of the gas tanks are 11,5 meters high (Lauferts le Roux & Mavunganidze 2016:40) yet a site inspection revealed that only about 8 meters are above ground. After this design iteration it was also found that the scheme should make a much more meaningful contribution to the plaza to the south-west.

7.5.2) Design iteration 2

Reconstruction of the purification plant structure

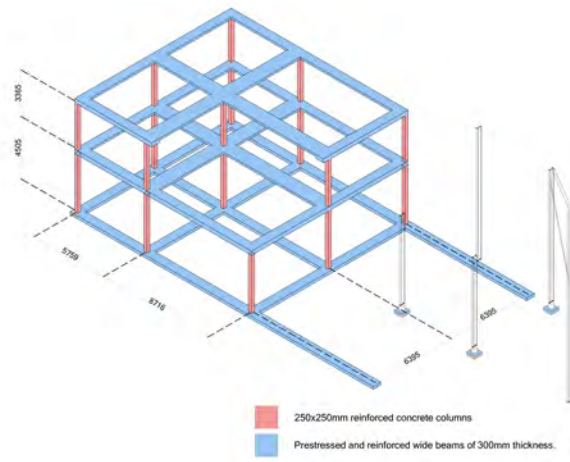
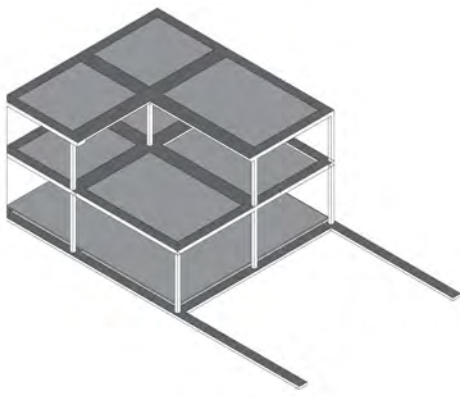
This design iteration entailed the reconstruction of the purification plant structure within which new spaces and forms could be accommodated. The design intention was that there would be a legible difference between new form and reconstructed heritage form.

Concluding the matter of reconstruction

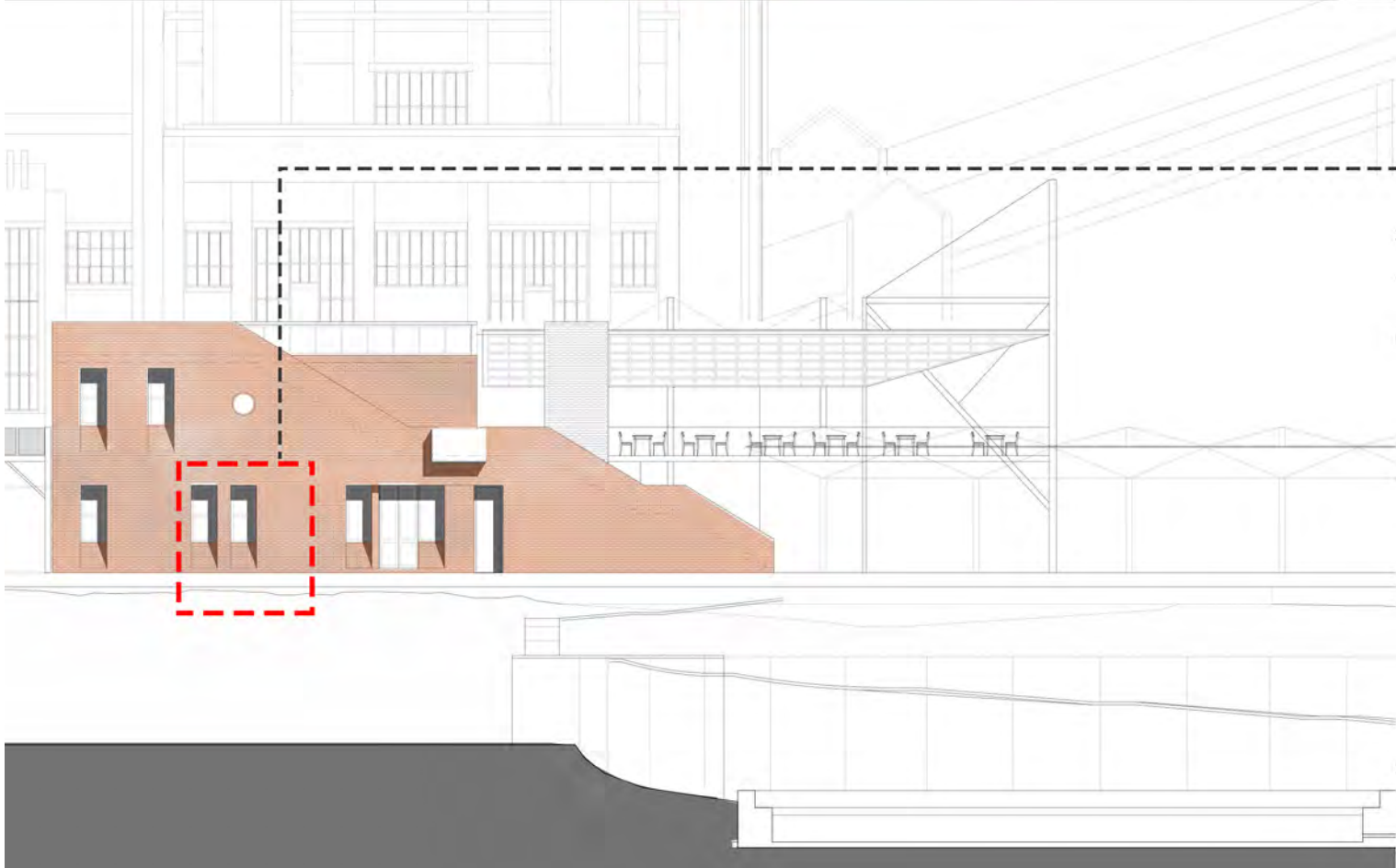
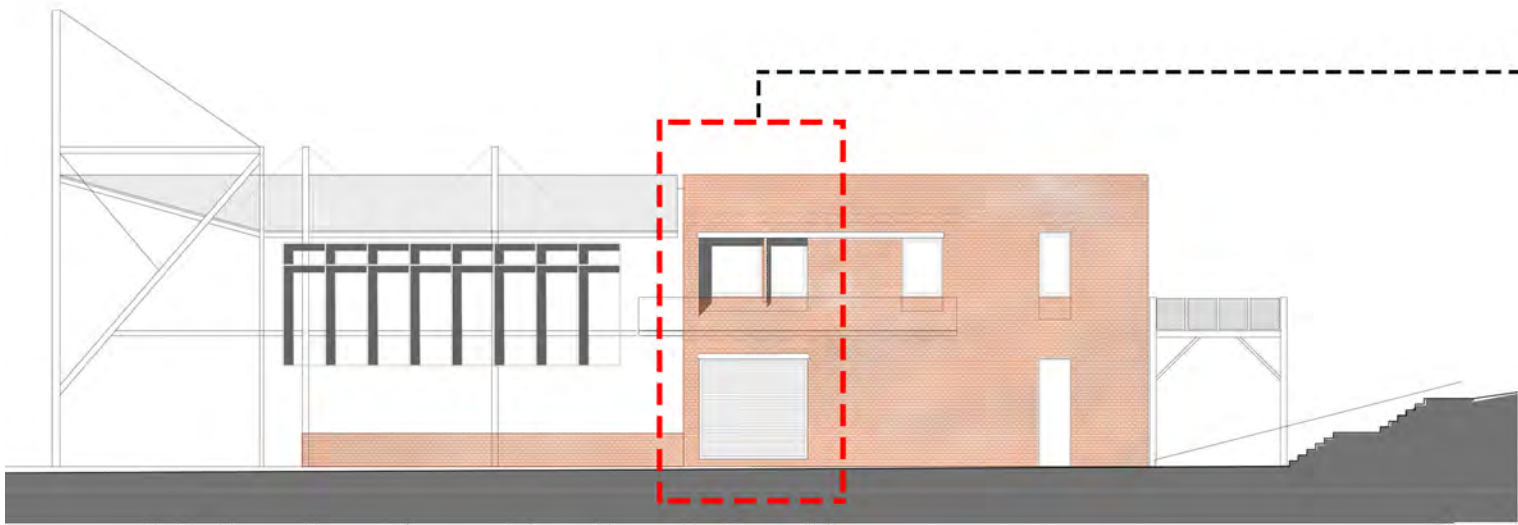
This iteration did not however contain any interrogation of the appropriateness of reconstruction. As discussed earlier, the purification plants' structure provided the required height for the flow of purified gas towards the distribution plant. Therefore, its form was derived from practical considerations and thus the reconstruction of the building for vastly different purposes would be an ill-considered formal exercise that does not communicate the uniqueness of the new intervention. Therefore, after this iteration, the building form broke free from any direct reference. Making reference to the original portal frame of the Purification plant however remained a design challenge.



Figure 94 Design iteration 2 (Author, 2017)



7.5.3.1) Design iteration 3. Building 1



① Southwestern elevation openings

The openings facing Retort No. 2 derive their widths from the openings in Retort No. 2's front facade. In this iteration, the facade did not express the structure, which was a concrete column and beam grid set back from the building edge.

② Northeastern facade

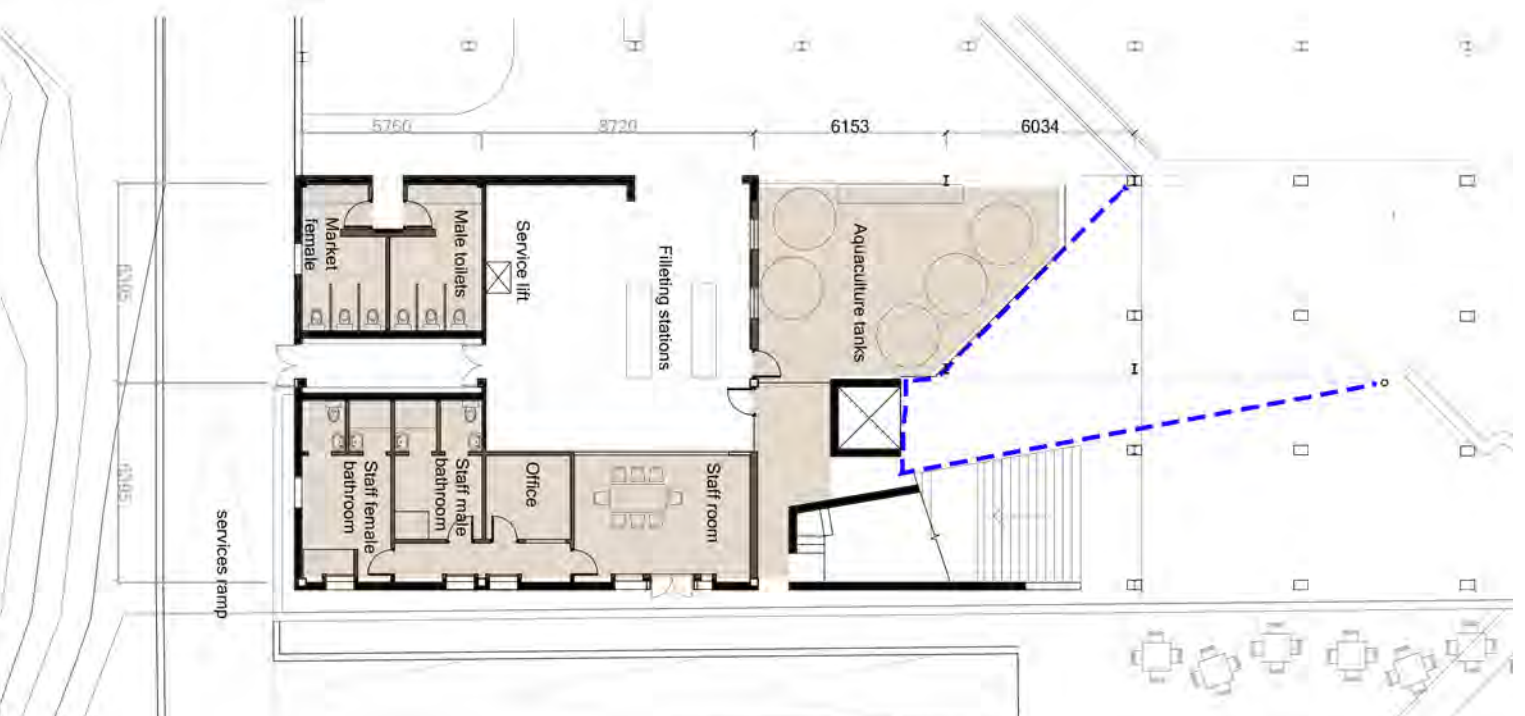
The northeastern facade is designed to be read in conjunction with the front elevation of Retort 1 beyond. Although the same materiality would associate these two elevations, the difference in form is meant to represent the different nature of the "new" industry. Therefore, the rectangular rigidity of usual brick construction is challenged and a more inviting form is proposed that makes access to the top and a vantage point over the entire landscape possible.

③ Openings details

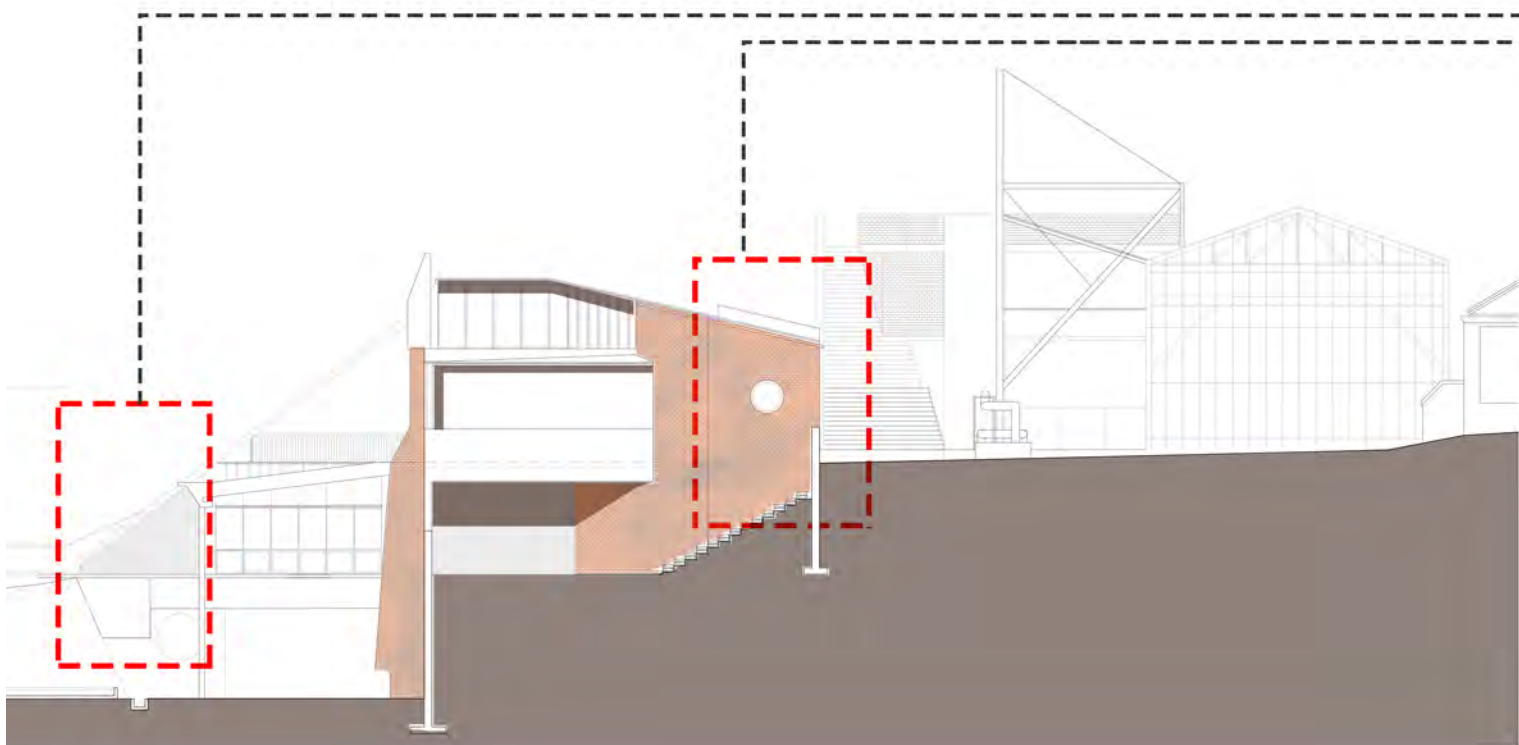
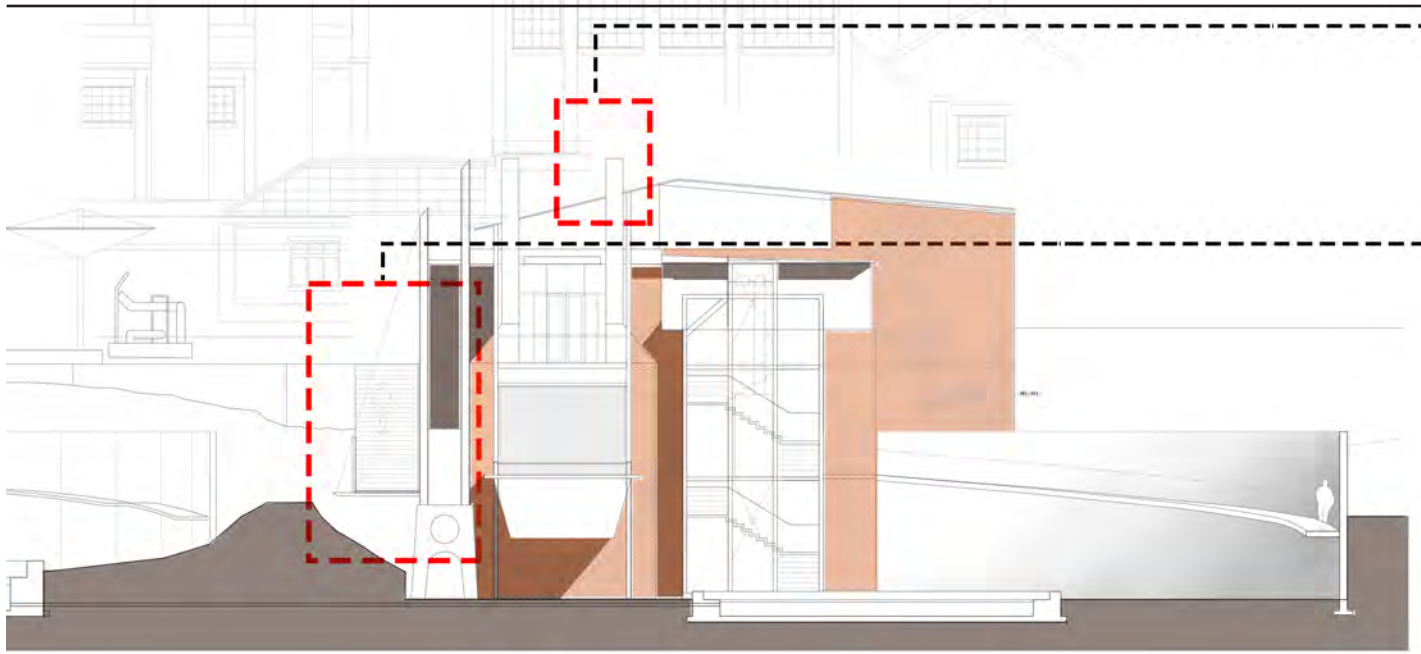
The openings in the northeastern elevation maintain solar control by their depth rather than overhangs. This also expresses the brickwork and its use more clearly. The narrower widths were found to be most appropriate for openings within a non-rectilinear facade.

④ Angles in plan

The angles seen in the stair form and breeding tank room (see below) are meant to draw the public from the plaza towards the building by creating a visual focal point on the circulation and access points.



7.5.3.2) Design iteration 3. Building 2



① Solar stacks

The implementation of solar assisted stacks meant that the service floor could be ventilated more effectively since the floor is submerged and used for handling waste. This also meant that the genius loci of the site could be maintained by the introduction of this industrial aesthetic.

② the Stair

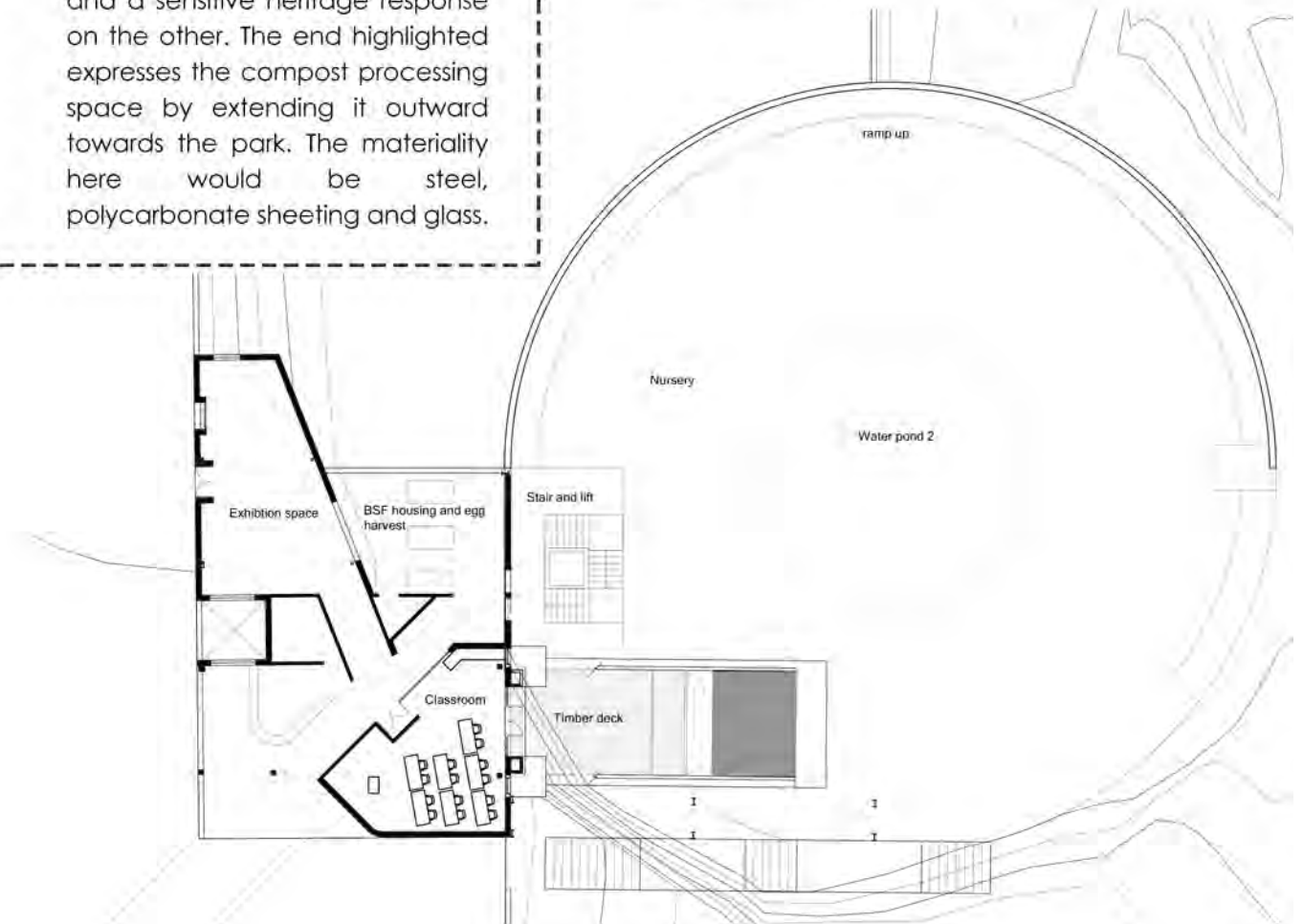
Designing the outdoor public stair in such a way that touched the ground lightly was realized in this iteration through a separate structure against building No. 2. This iteration made it clear however that the stair should be part of the building, allowing visitors to see more of the internal processes.

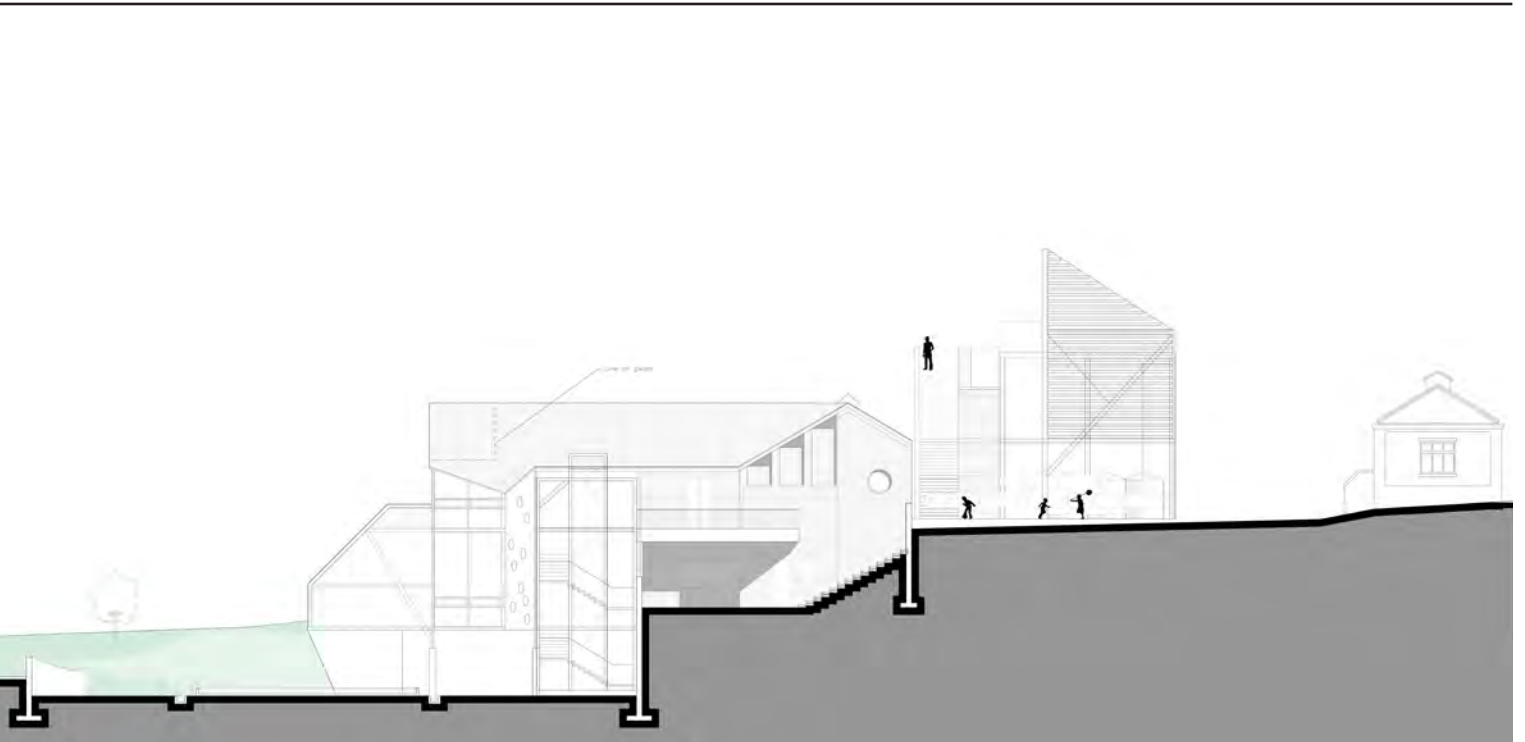
③ Ecological industry

Buildings no. 2 was conceived as one edge condition becoming another - ecological industry serving the park on the one end and a sensitive heritage response on the other. The end highlighted expresses the compost processing space by extending it outward towards the park. The materiality here would be steel, polycarbonate sheeting and glass.

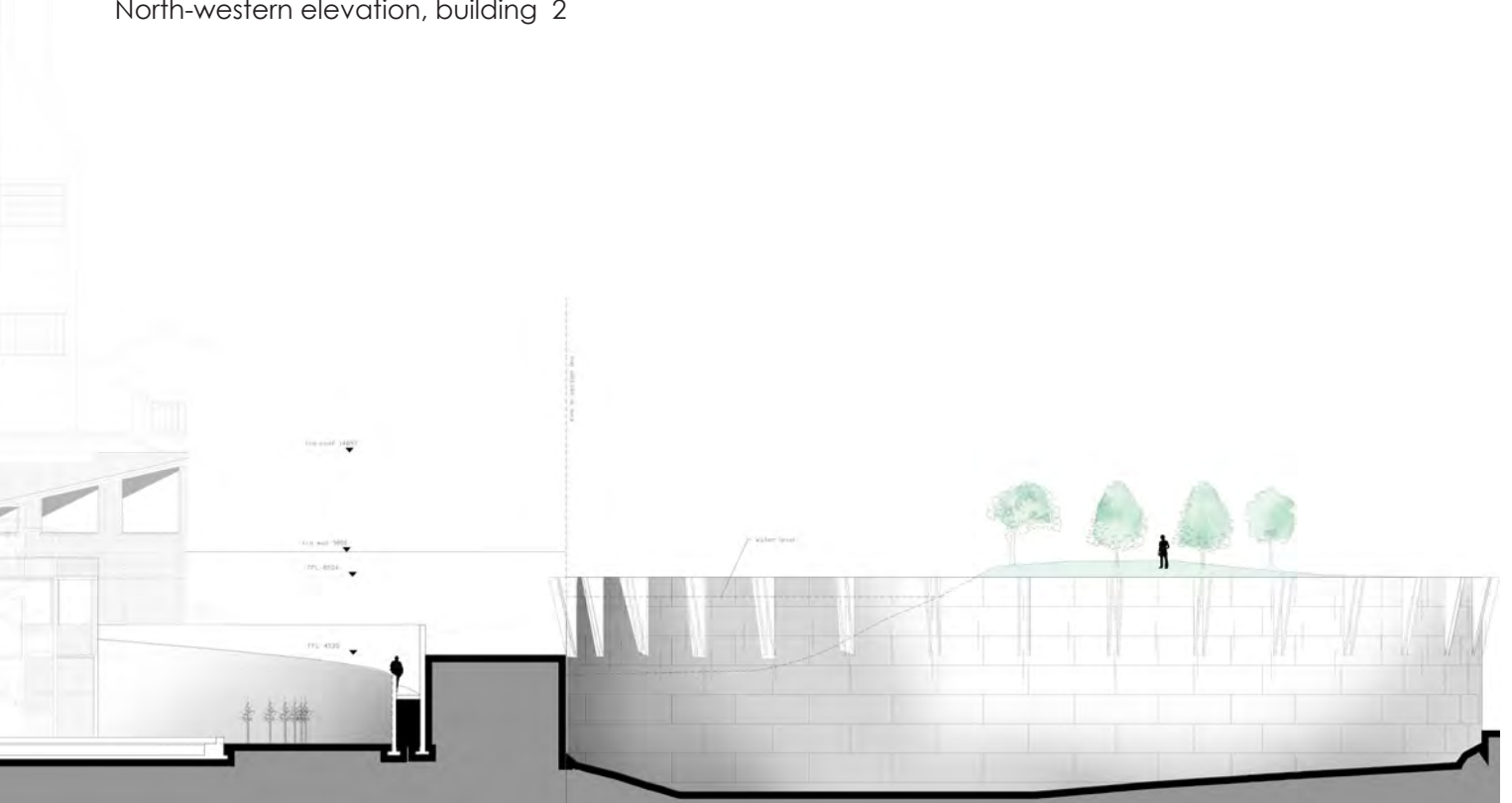
④ Industrial heritage

The back end of building No. 2 responds to the heritage building adjacent (distribution plant) through its scale, materiality and roof although the following iteration achieved this more successfully.





North-western elevation, building 2



7.6

Facade analysis as design informants

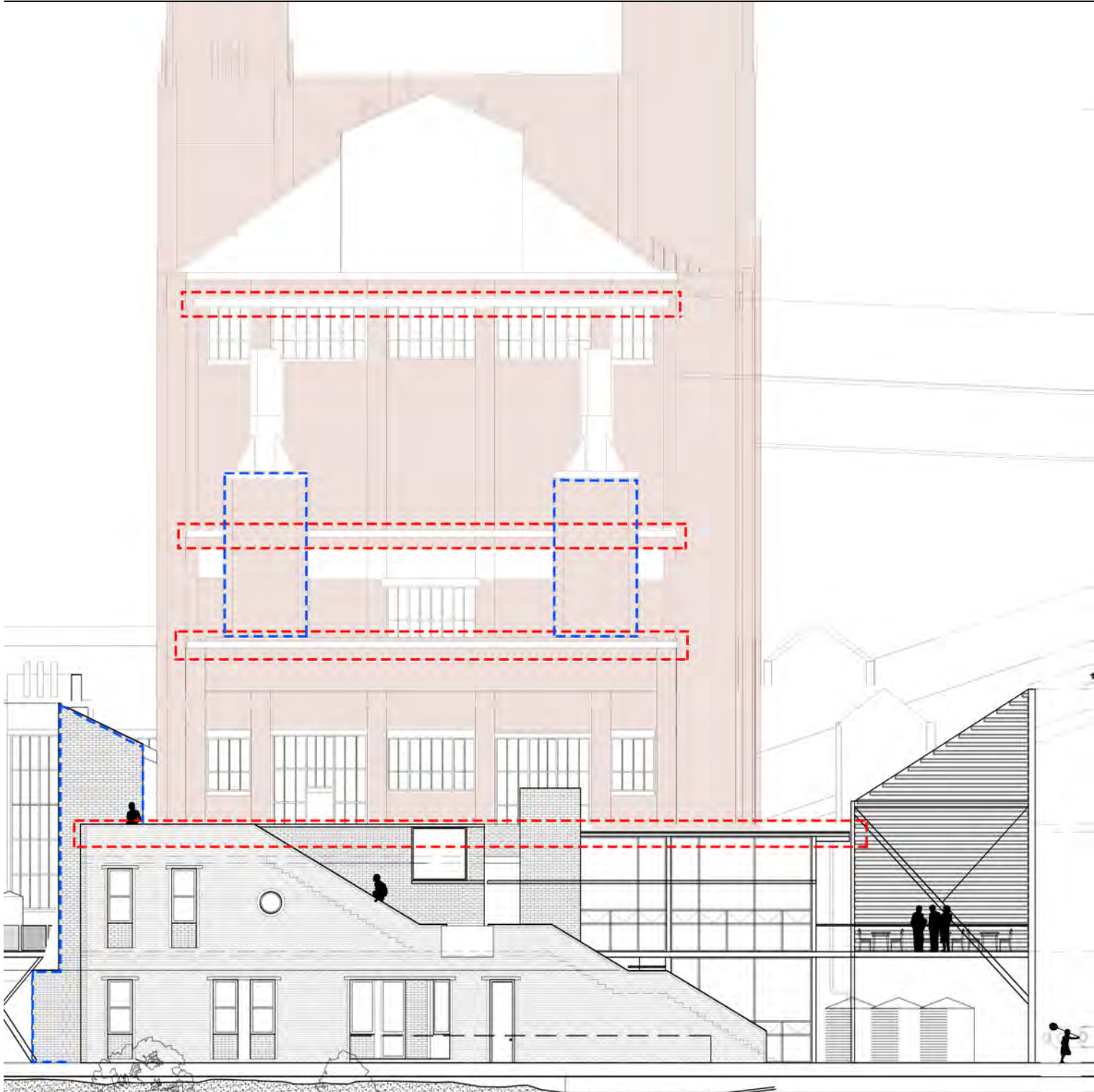


Figure 96 Facade analysis of building 1 (Iteration 5) and Retort no. 2 (Author, 2017)

Design decisions related to the form of Building 1 and Building 2 were derived from their positions in front of the Retort buildings. For Building 1 the relatable feature was chosen to be horizontality in the facade whilst Building 2 derived its slanted steel roof from Retort 1 behind it. Employing a slanted tower-like element at the back of Building one not only related it to the towers of Retort 2 and the external stair of the building but assisted in passive ventilation strategies that will be explored in the following chapter.

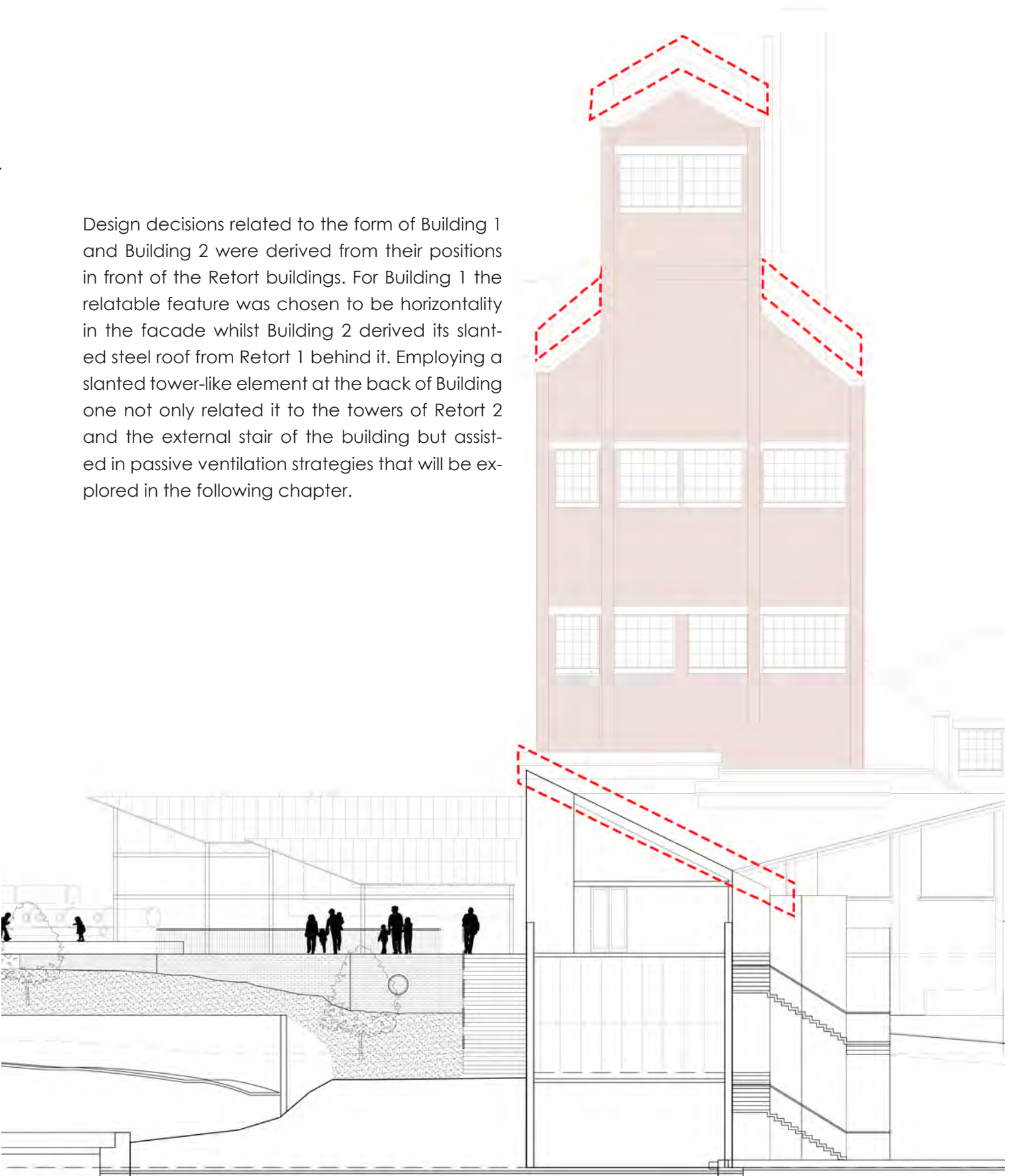
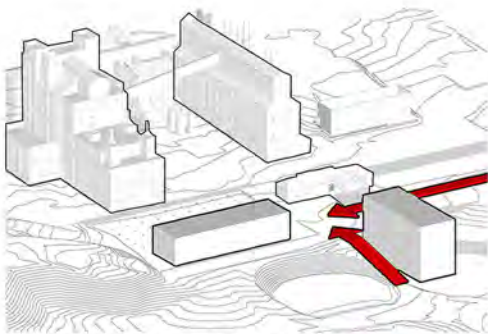
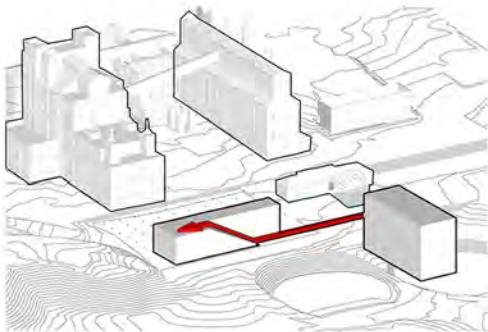


Figure 97 Facade analysis of building 2 (Iteration 5) and Retort no. 1 (Author, 2017)

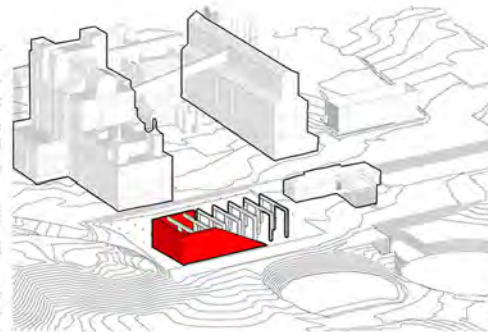
7.7 Iteration five design drivers and resolution



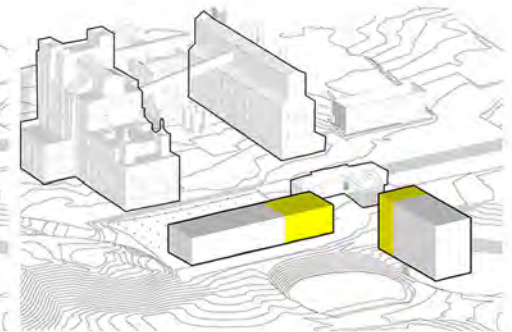
Pedestrian access from the park



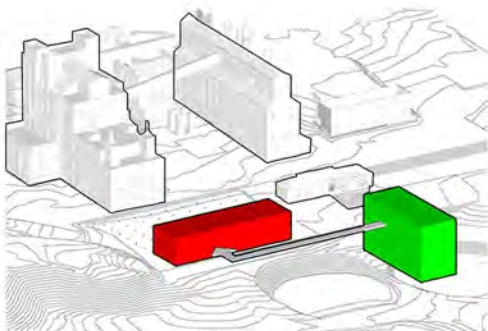
Building one's response to movement



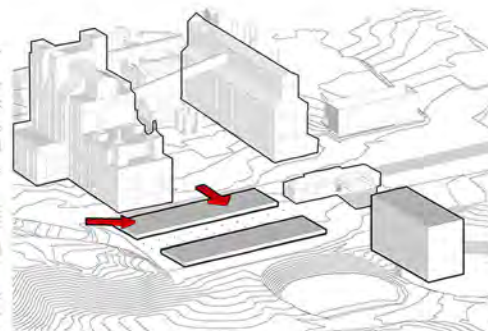
Tectonic response to movement



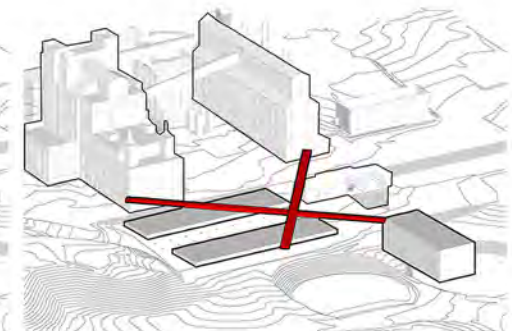
Allocation of private and public



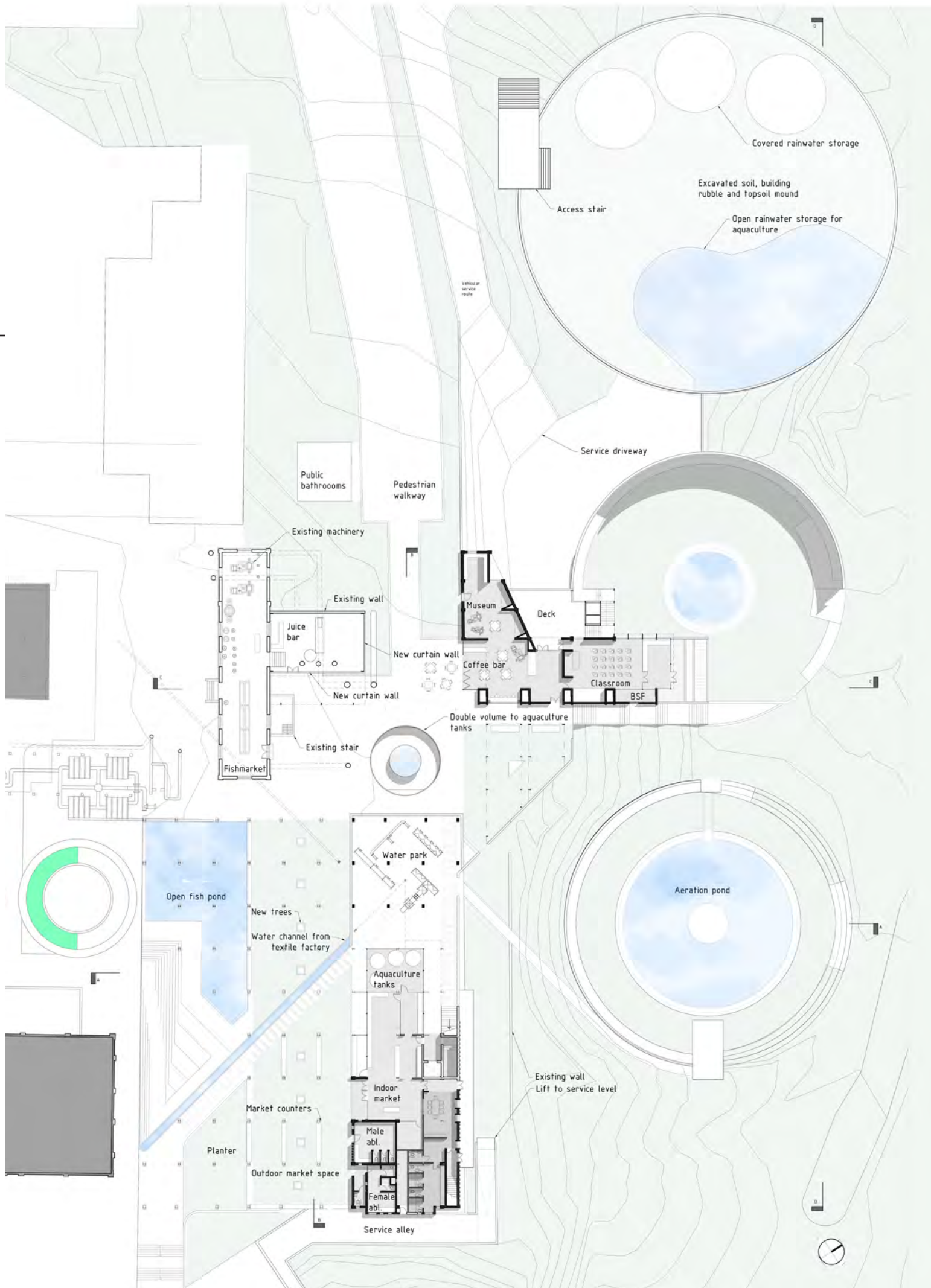
Allocation of the "giver" and "receiver" as two co-dependant entities.



The allocation of different zones



Juxtaposition of perpendicular geometry



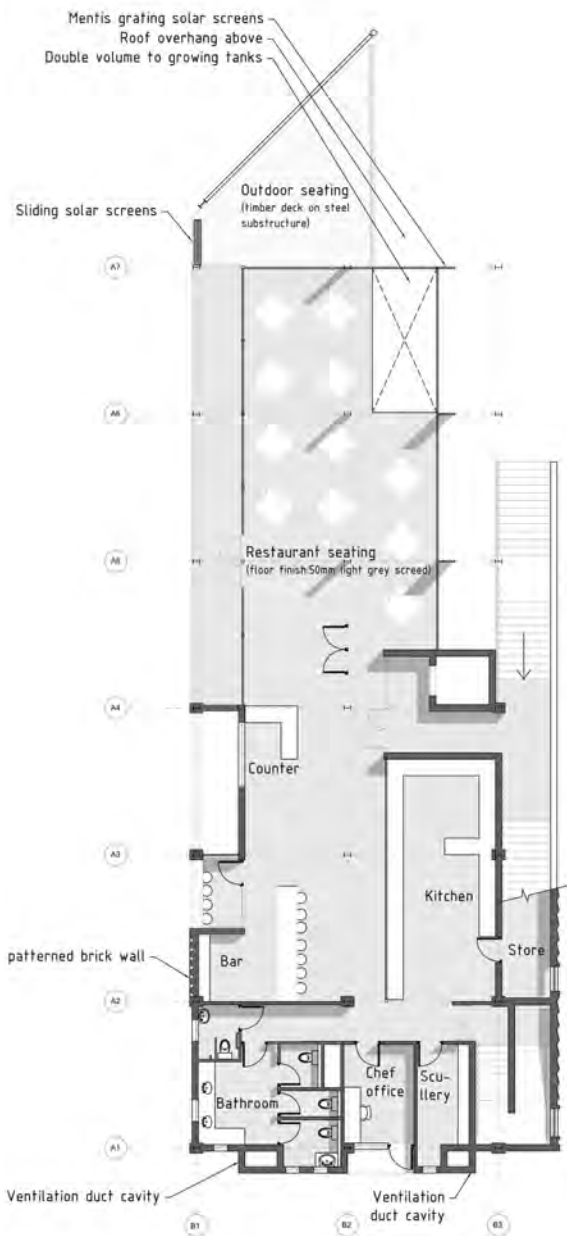


Figure 100 Building 1 first floor plan (Author, 2017)

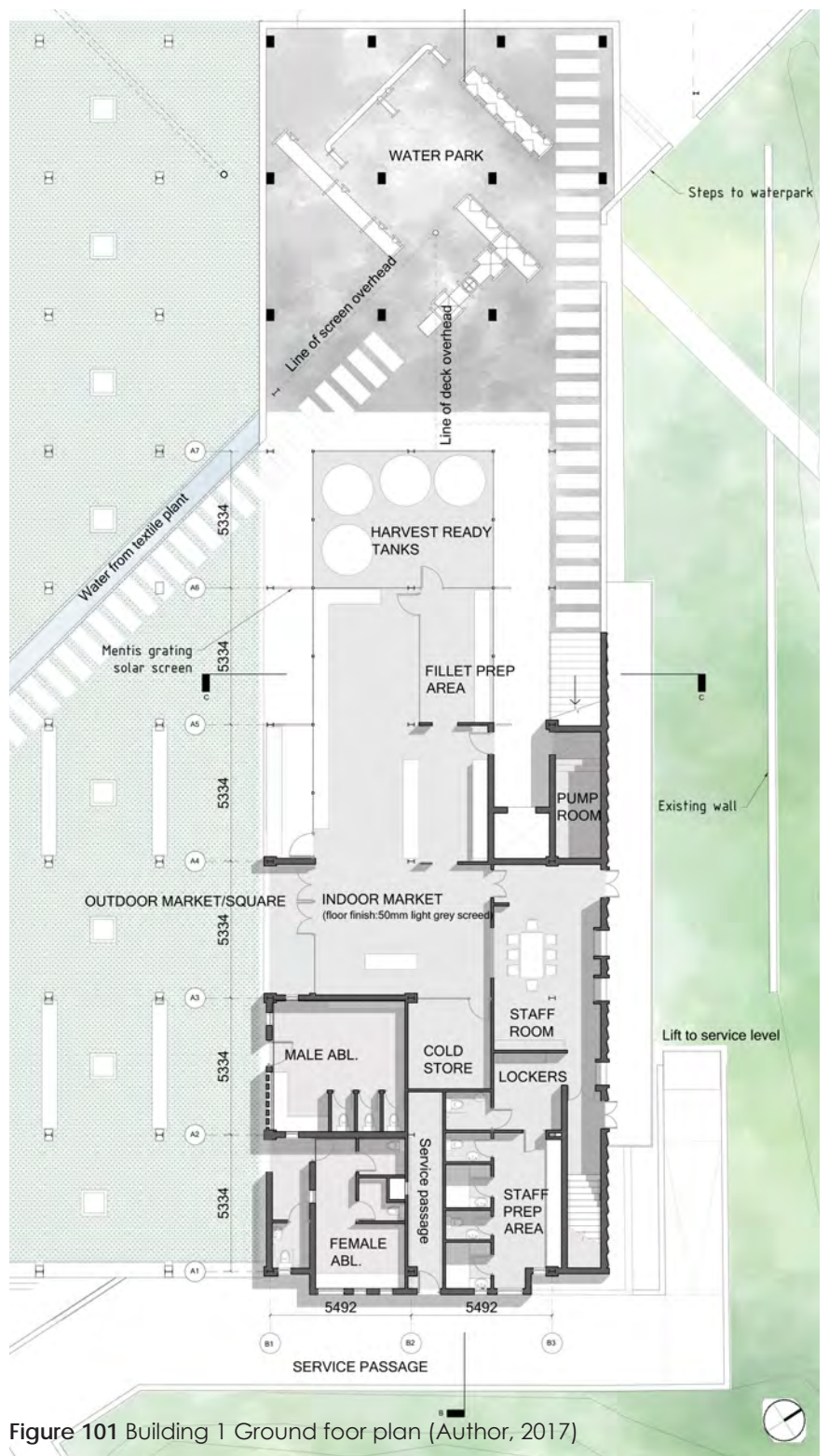


Figure 101 Building 1 Ground floor plan (Author, 2017)

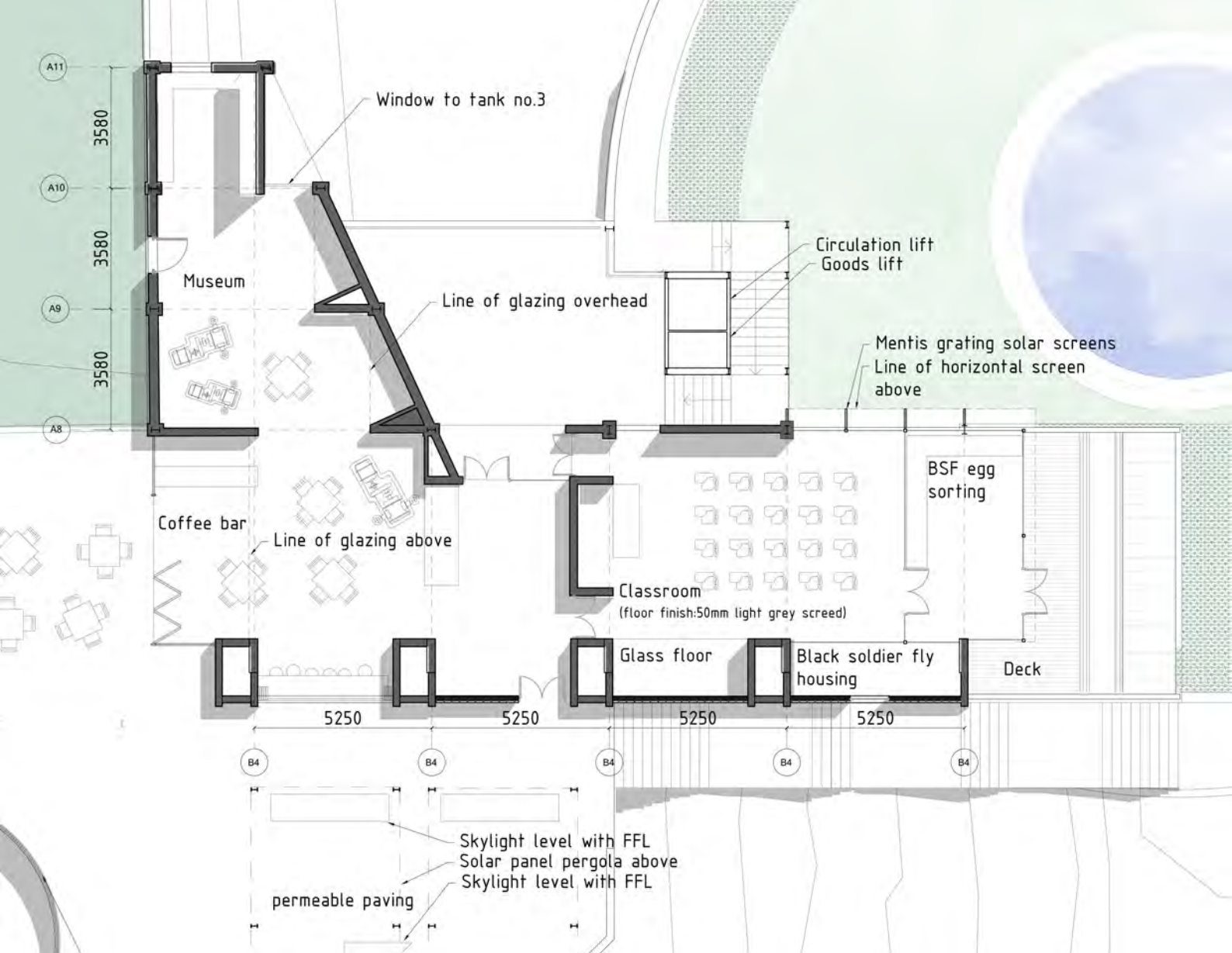


Figure 102 Building 2 square level plan (Author, 2017)

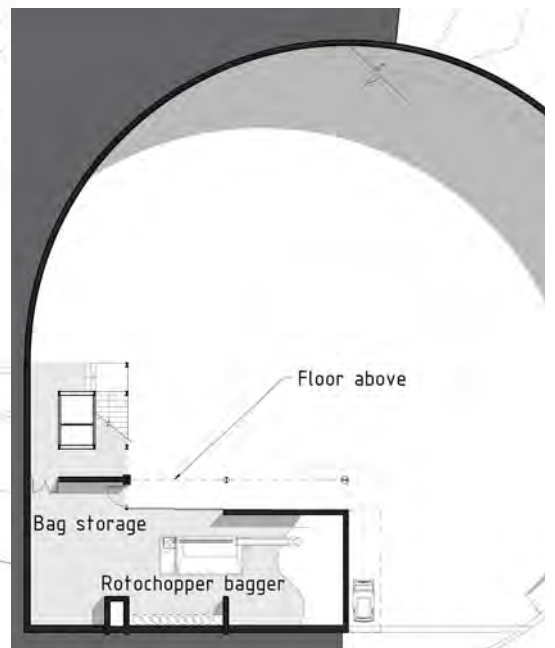
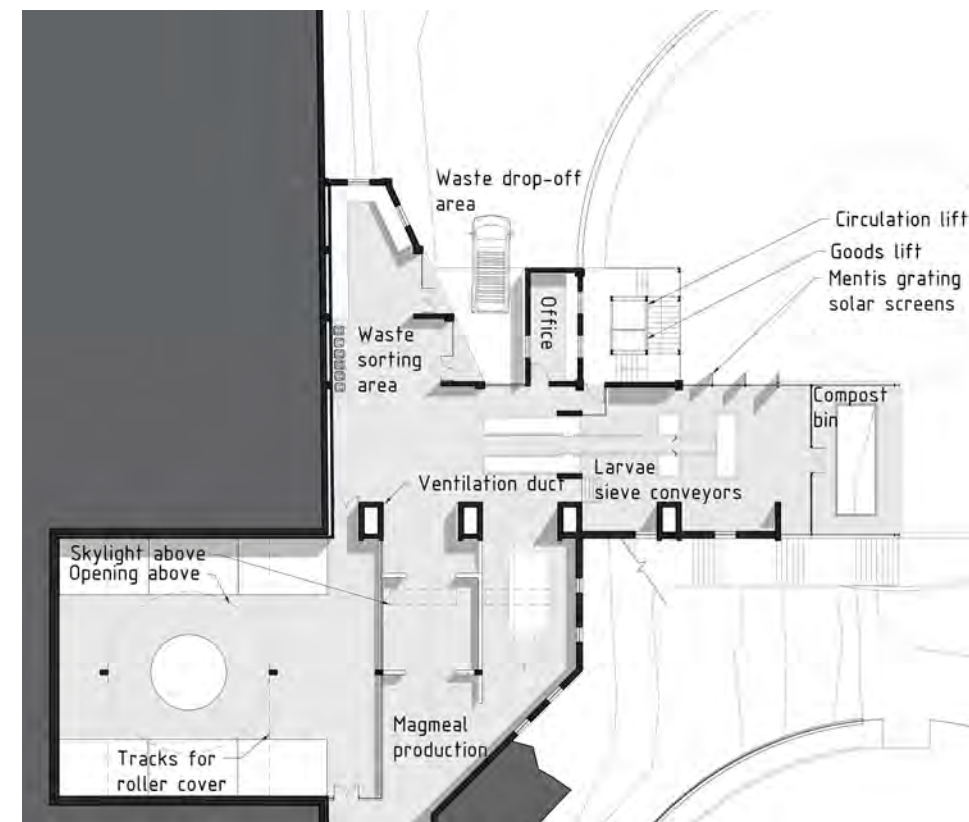


Figure 103 Building 2 service level plan (Author, 2017)

Figure 104 Building 2 park level plan (Author, 2017)



Figure 105 Southwestern elevation (Author, 2017)

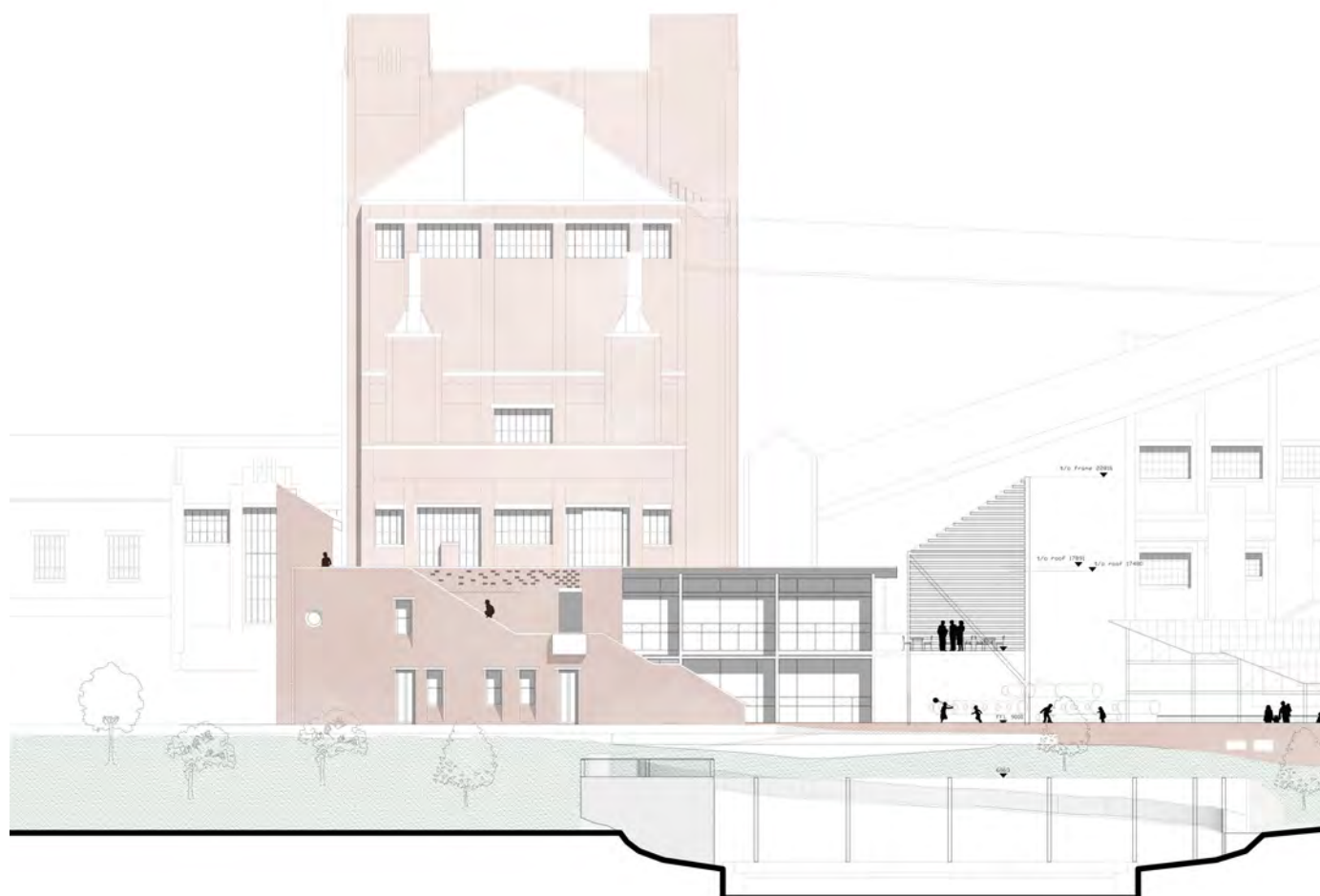
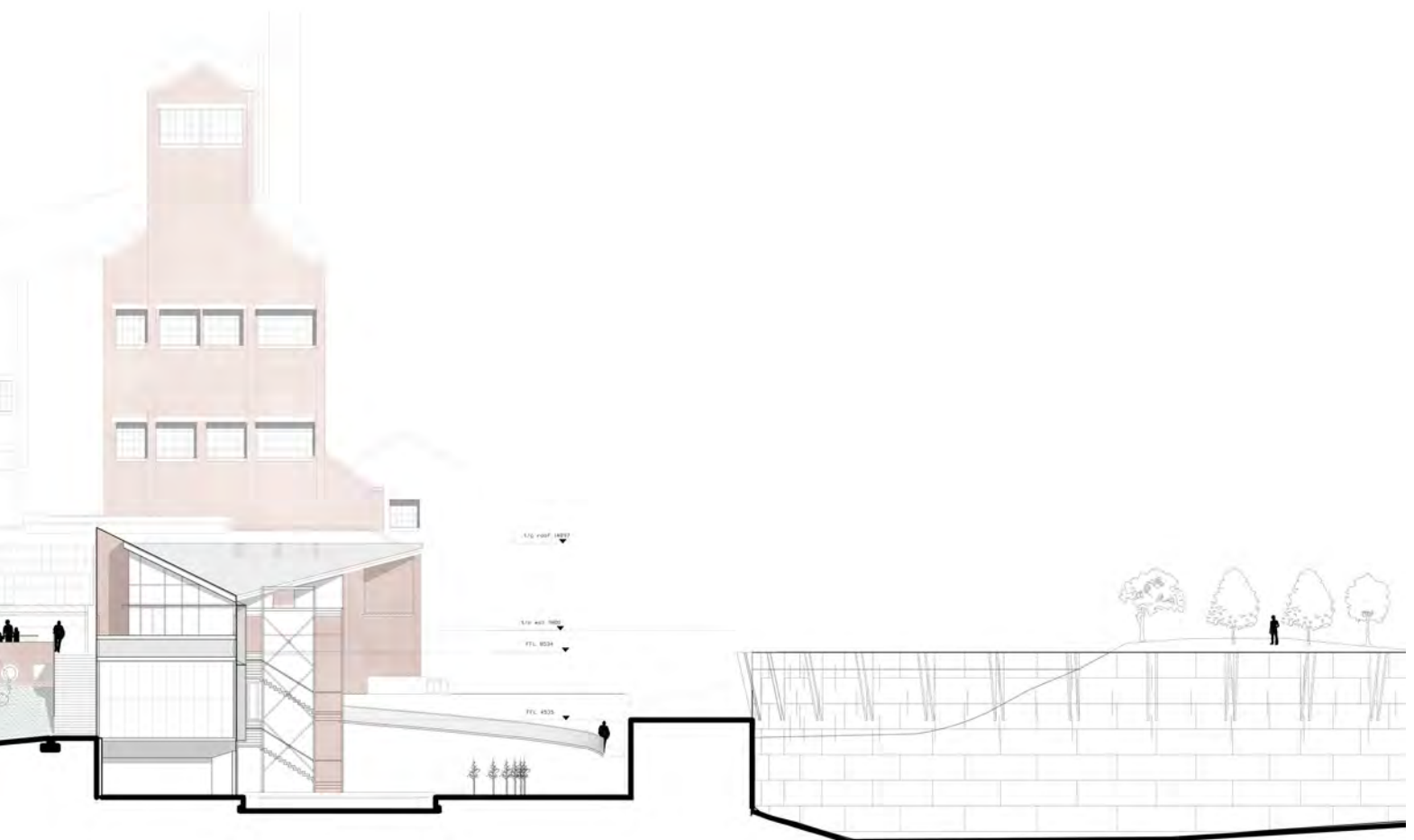


Figure 106 Northeastern elevation (Author, 2017)



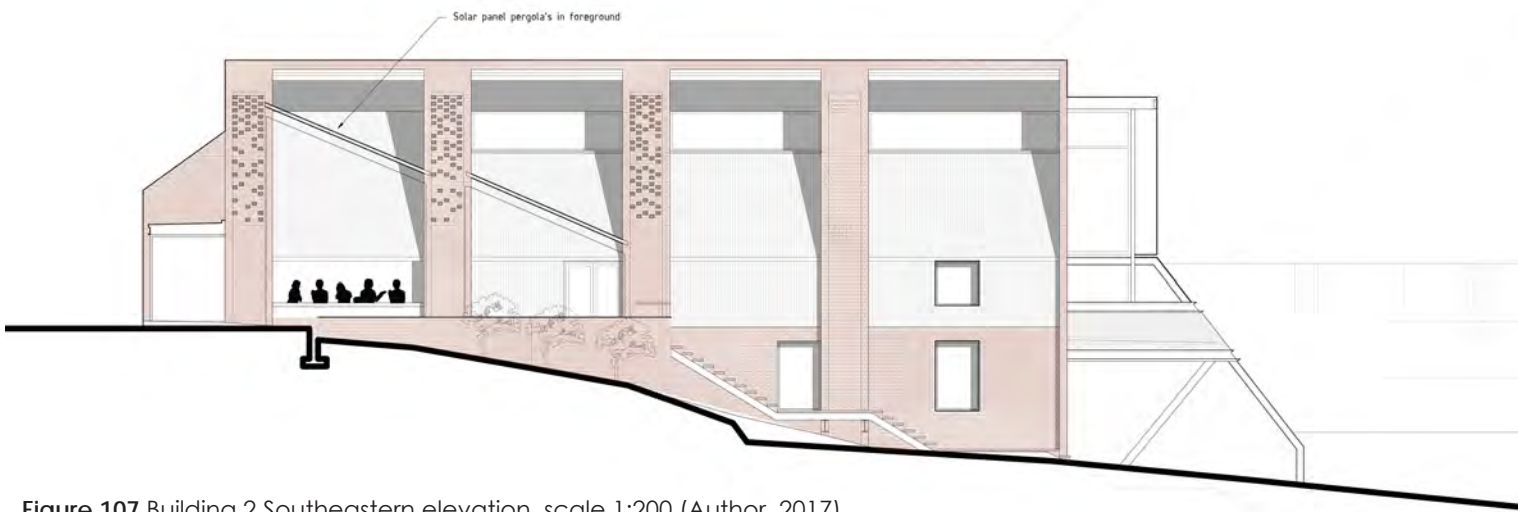


Figure 107 Building 2 Southeastern elevation. scale 1:200 (Author, 2017)

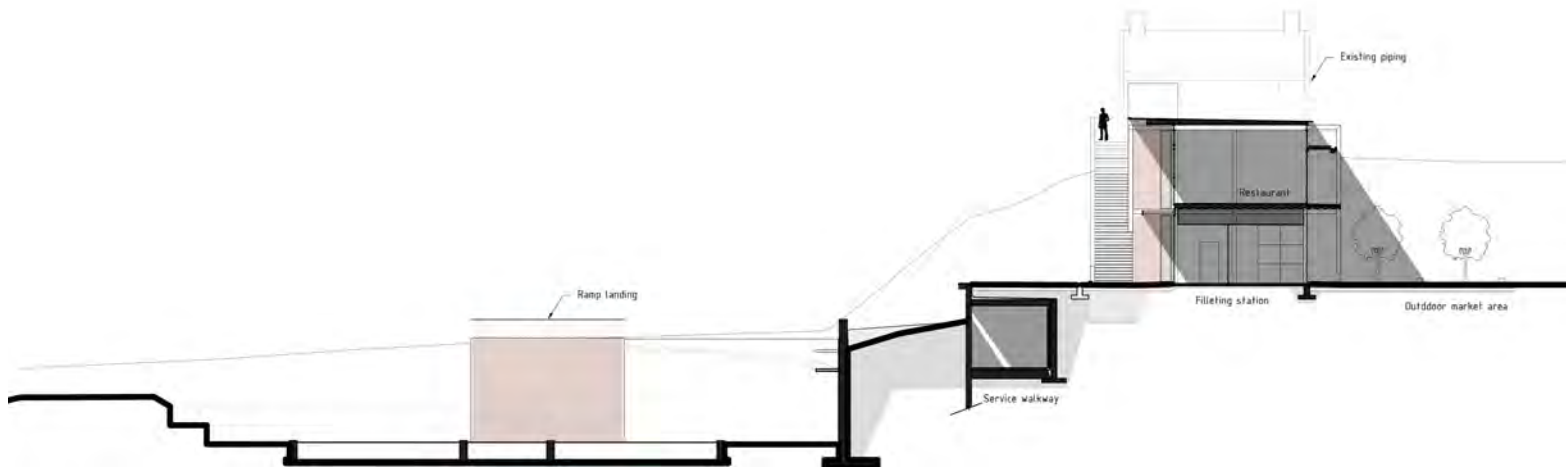


Figure 108 Building 1 cross section (Author, 2017)

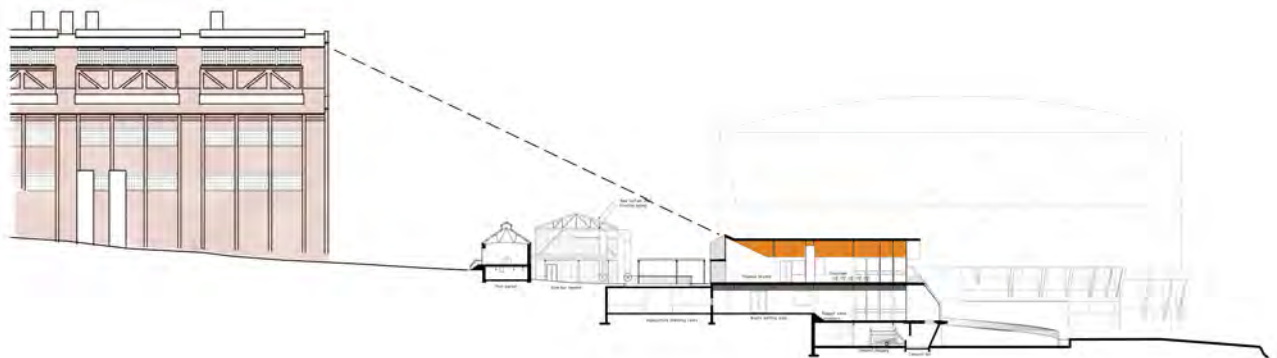


Figure 109 Building 2 Longitudinal section (Author, 2017)



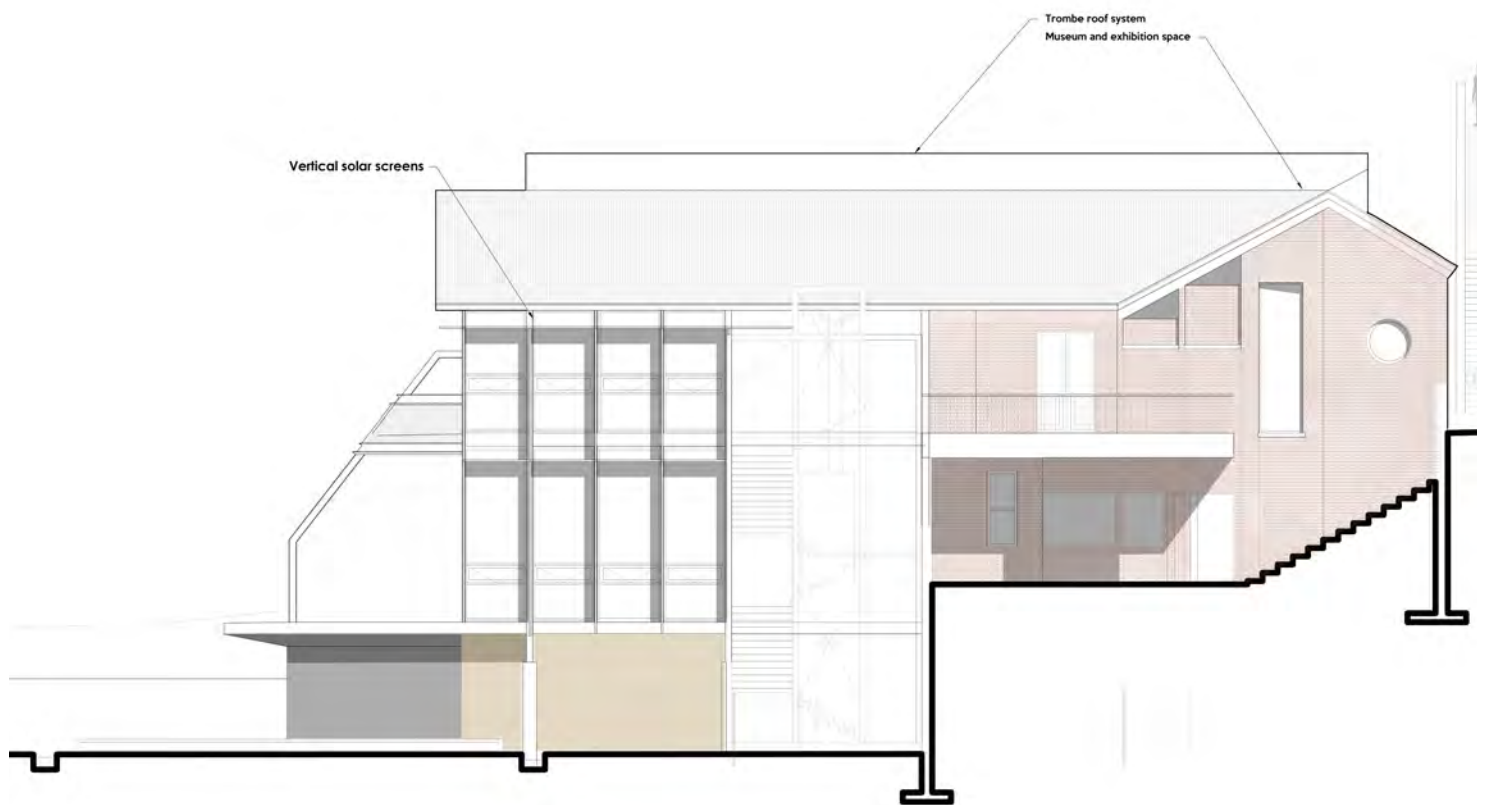
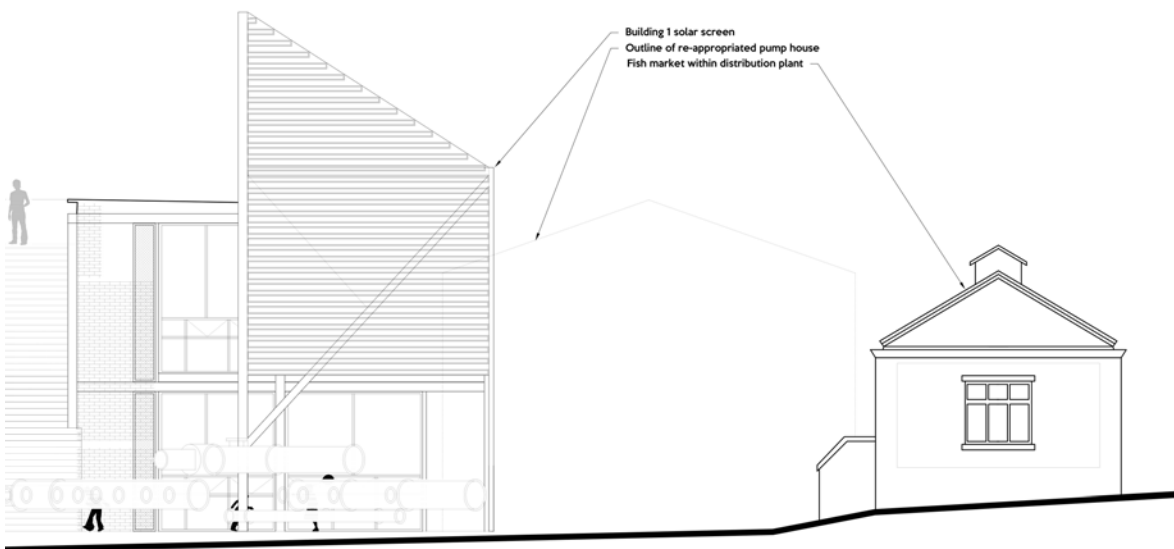
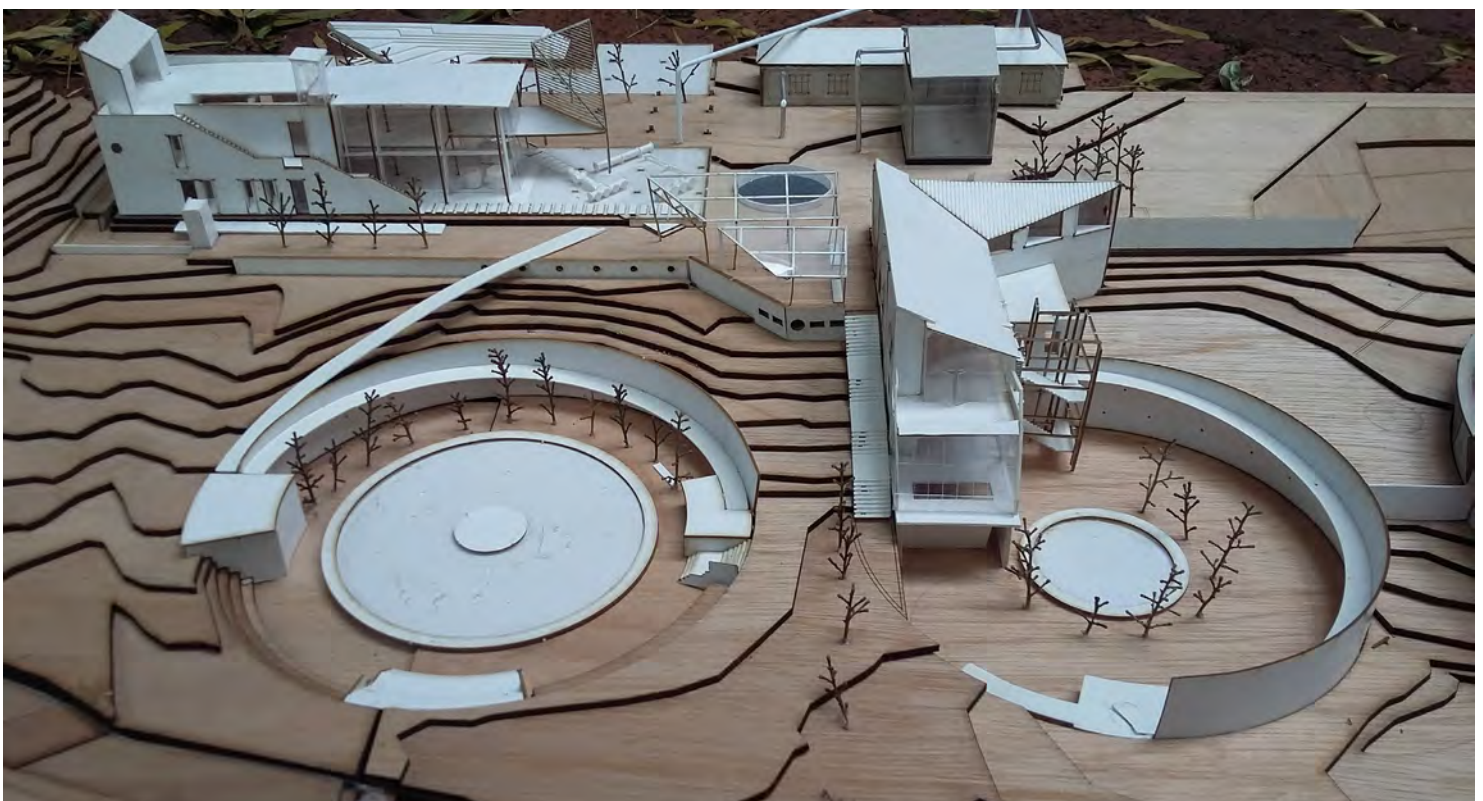
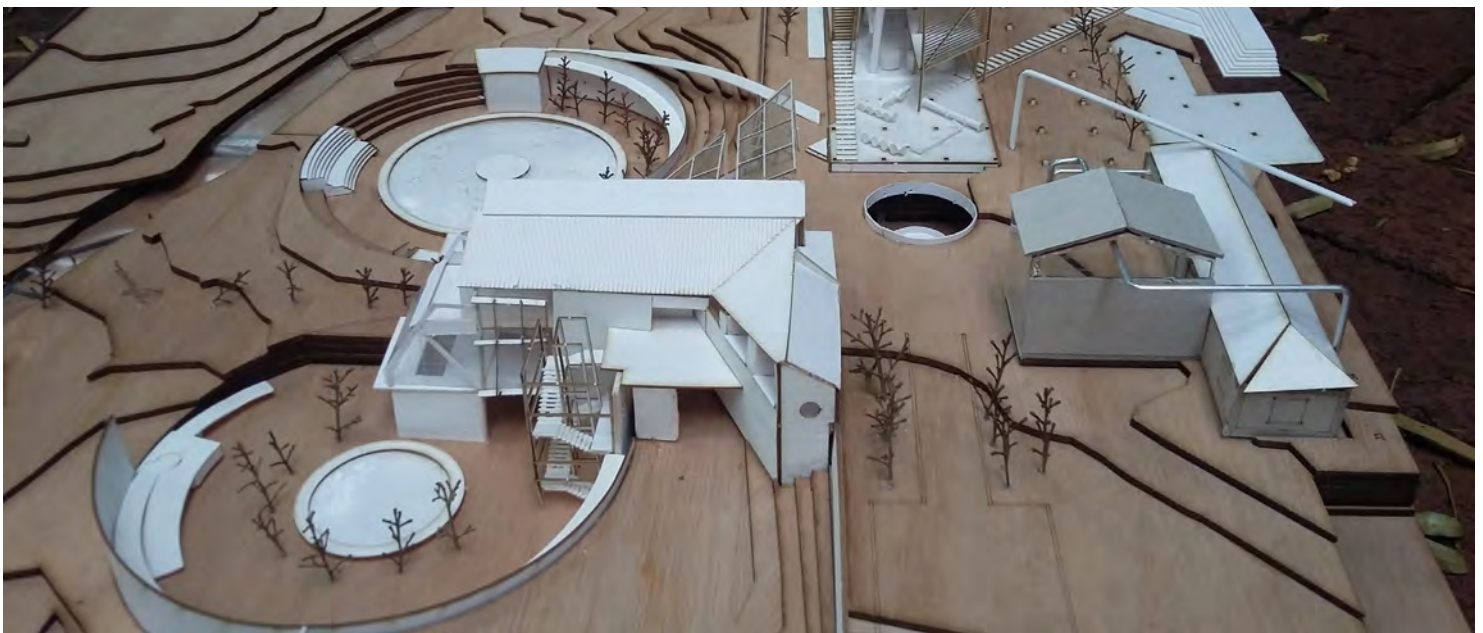
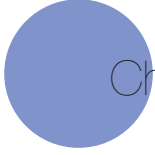


Figure 110 Northwestern elevation. scale 1:200 (Author, 2017)









Chapter 8

Detail technical resolution

Figure 111 Closeup photograph of Livesey scrubber

Figure 112 Steel structure in Retort 2 interior

Figure 113 Livesey washer deconstructed envelope and piping exposed

Figure 114 Western entrance to Retort No 1

8.1.1 Material palette of the Gas Works

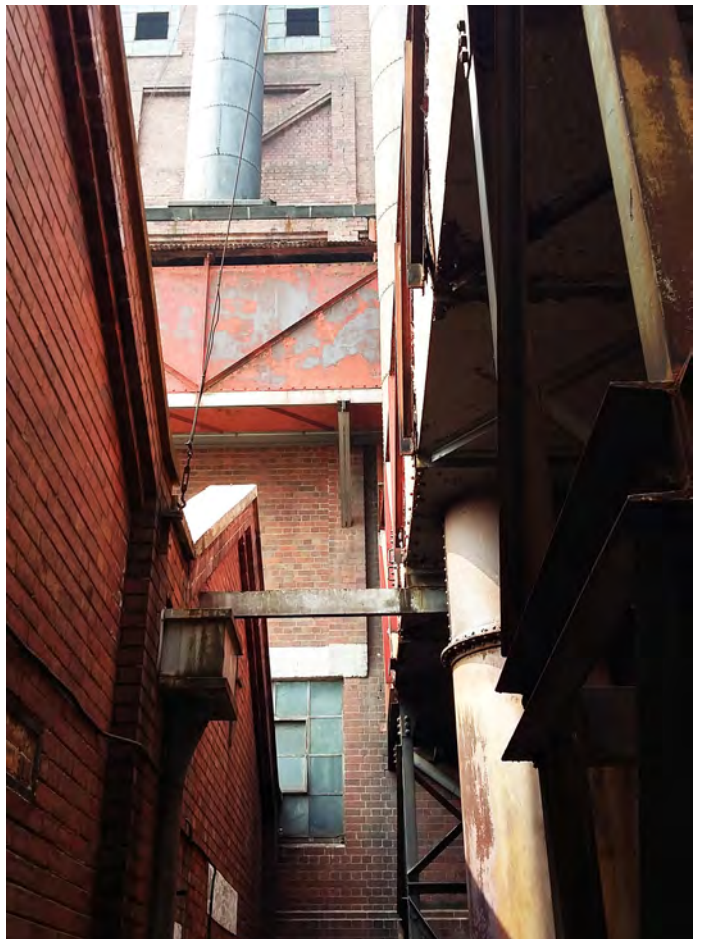


Figure 115 . CWG plant Eastern elevation with structure expressed in facade
Figure 116 Retort 1 western facade with brick-clad cross bracing expressed
Figure 117 Opening detail of Retort No 2 northern facade



8.1.2 Construction techniques and details

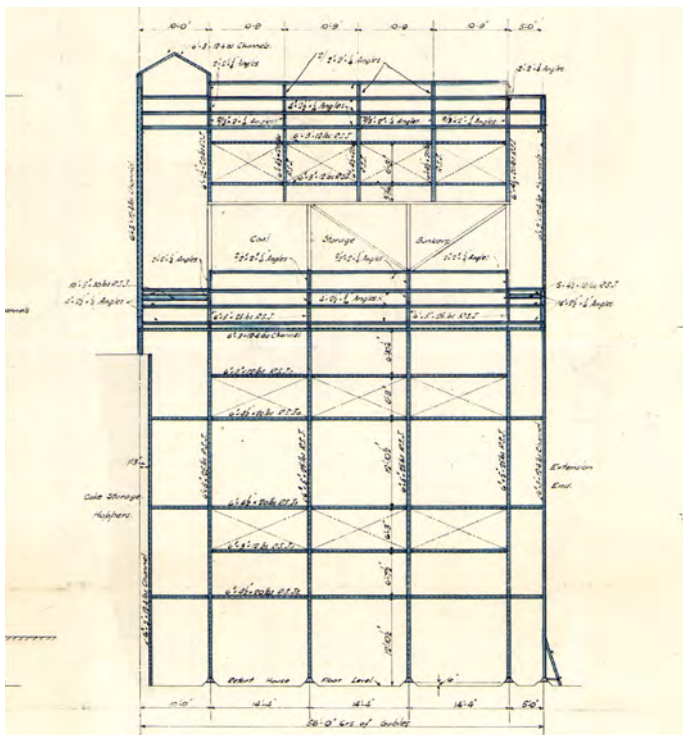


Figure 118 Steel structure of Retort No. 1



Figure 119 South-eastern facade of Retort No. 1

Before deciding on a technological concept to resolve the construction methods employed, a thorough understanding of the construction technology used on the Gasworks site is necessary. In a scheme that seeks to respond to heritage, the materiality, scale and construction need to be resolved in such a way that the uniqueness, the Genius Loci of the site is maintained whilst still standing apart as a response or a "translation" into contemporary architecture.

The most iconic buildings on the Gasworks site, the no. 1 and 2 retorts, offer a helpful understanding of how construction was used to embody the requirements of the coal to gas process. Since the process of coal burning and gas extraction required great height, steel construction was used to make the frame or skeleton of both retort buildings. Brick was used merely as an infill or envelope around the frame and it was done in such a way that the structural frame expressed itself in the facade - albeit more in the case in Retort No. 1.

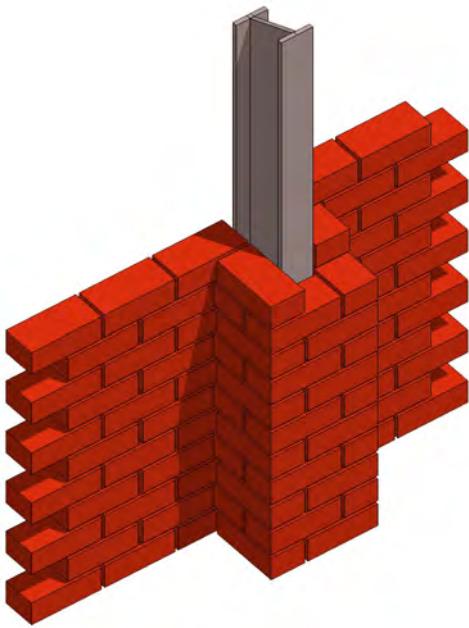


Figure 120 3D diagram illustrating facade detailing of Retort no. 1 & 2.

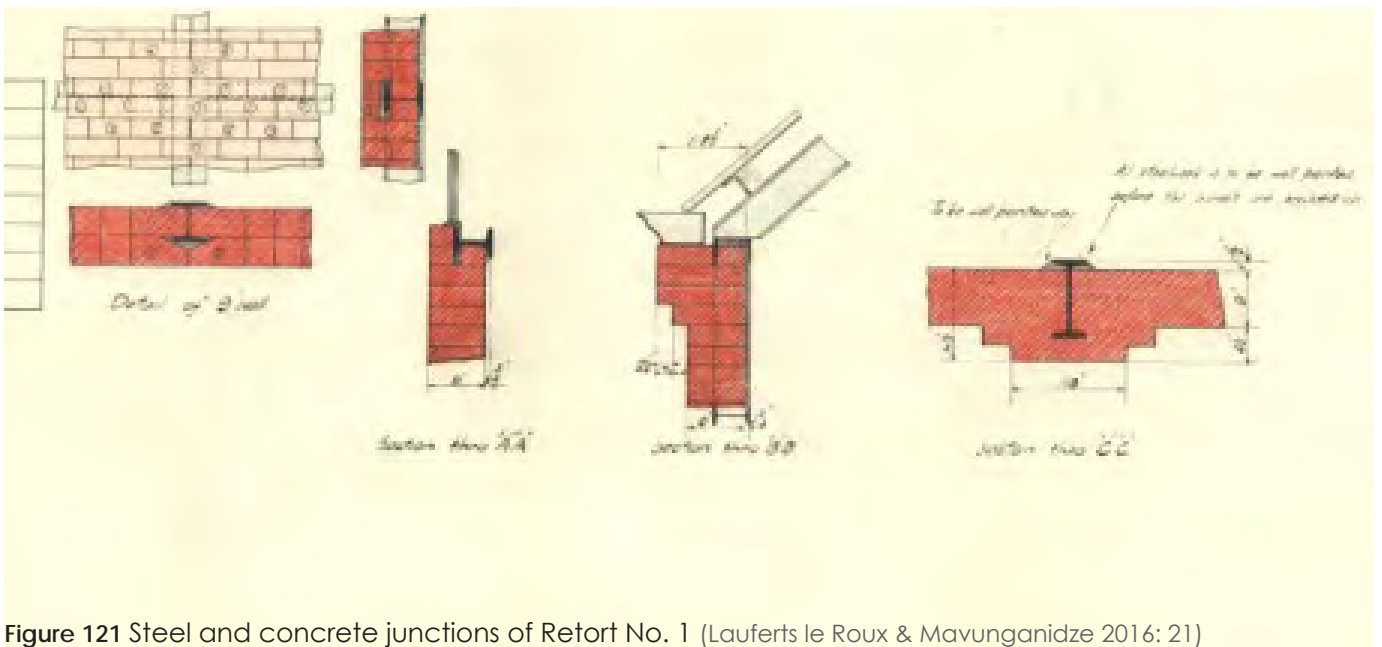


Figure 121 Steel and concrete junctions of Retort No. 1 (Lauferts le Roux & Mavunganidze 2016: 21)

8.1.3 Translating heritage elements into design



Figure 122 Concrete detailing around openings and structural expression (Photograph by Author, 2017)



Figure 123 Chimney towers, the relationship between openings and structure (Photograph by Author, 2017)



Figure 124 Brick eave detailing (Photograph by Author, 2017)



Figure 125 Chimney flues of Retort 1 (Photograph by Author, 2017)

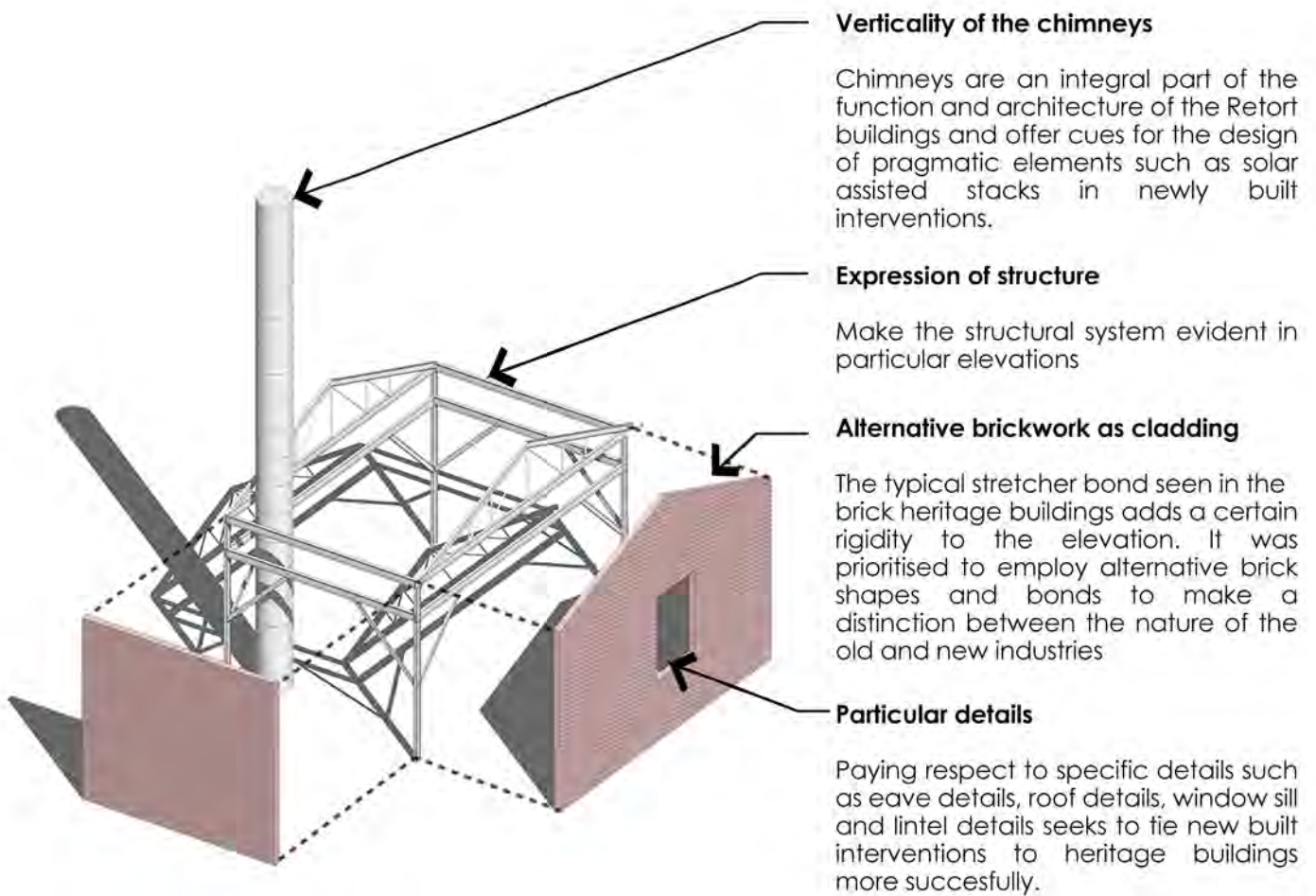
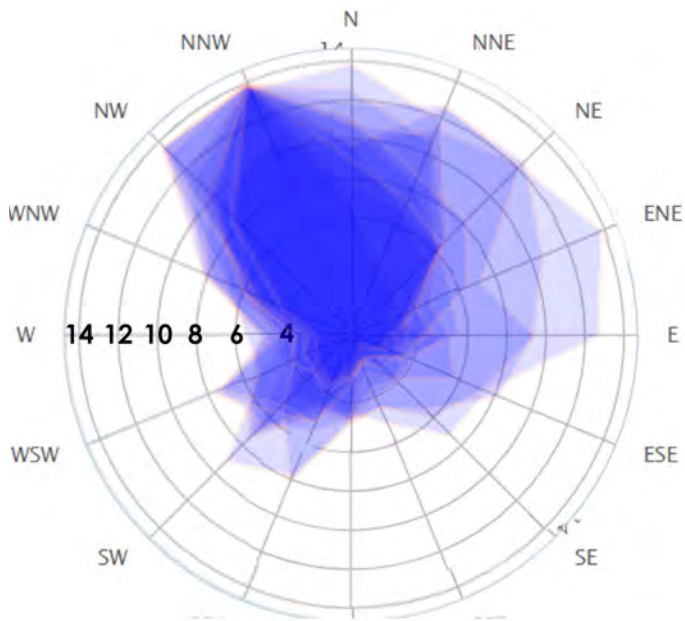


Figure 126 Construction elements of Gas Works site deconstructed (Author, 2017)

Below:

Figure 127 Wind direction distribution of Johannesburg showing 12 month overlaid. Image sourced from

8.2 Climatic analysis



Conclusions

Following the climatic analysis of the site it was found that in the detail technical resolution stage of design development north-northwestern wind would have to be controlled since a significant access route and recreational open space (water park) was aligned according to this direction.

Johannesburg is located within the cold interior climatic zone of South Africa (SANS10 400-XA:2011). This, coupled with the fact that building No. 2 (northernmost on Figure 130) has a large excavated services floor, the main passive strategy employed for both buildings was passive ventilation through Trombe assisted stacks and geothermal piping.



Figure 128 Summer solstice shadow paths

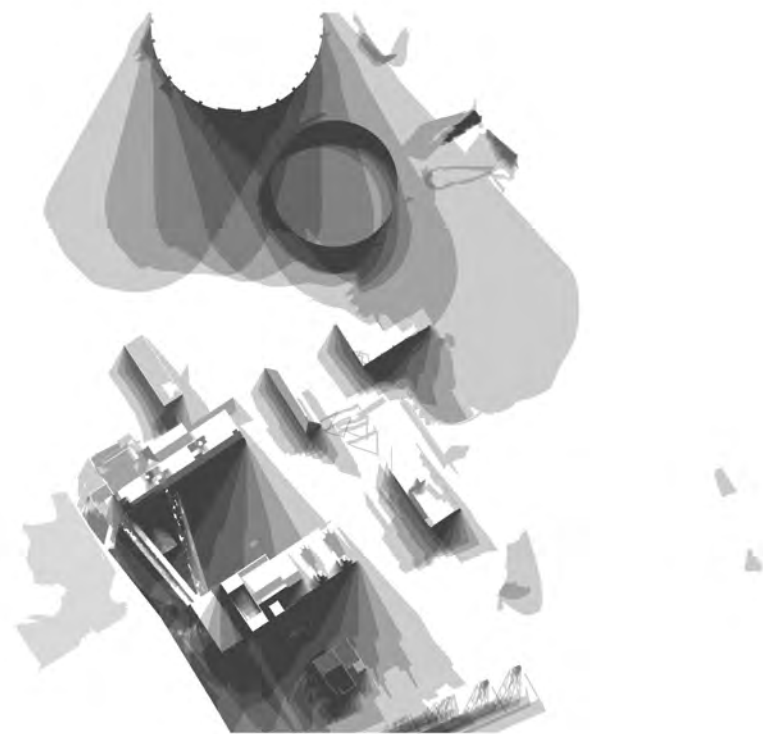
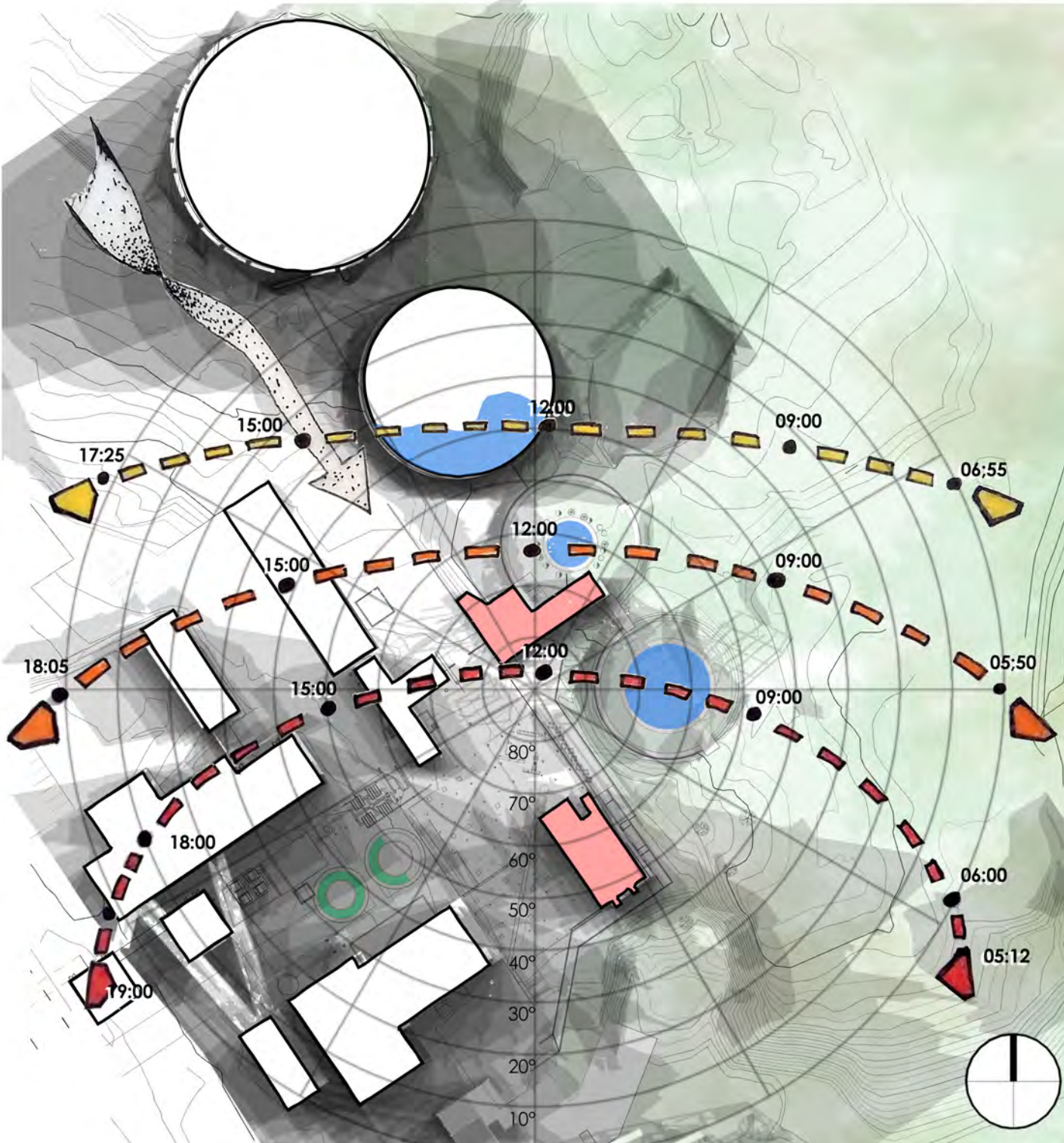


Figure 129 Winter solstice shadow paths

Below: Figure 130 Climatic analysis with September solstice shadow paths



Right: **Figure 131** Structural system of Building 1 (Author, 2017)
 Below: **Figure 132** Reference plan for building 1 (Author, 2017)

8.3.1 Structural system Building 1

Structural system

For Building 1, it was decided that the structural system should follow the same spacing as the purification plant ruins, which are spaced 5,3m apart longitudinally. Structural steel is employed for the primary and secondary structure and brick as skin in order to employ the same construction method as used in the Retort buildings.

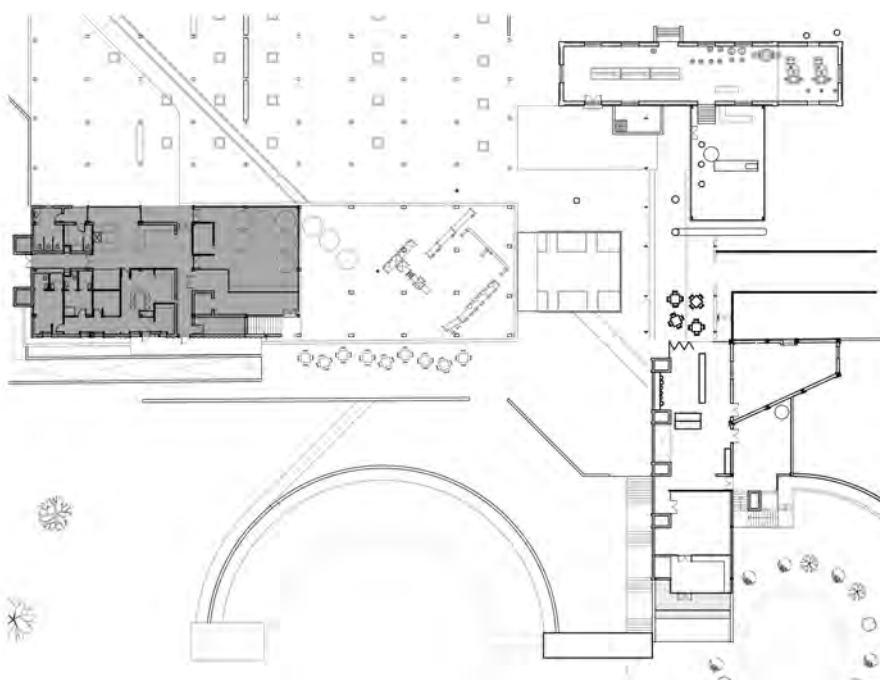
Permanent shuttering floor

Bond-dek permanent shuttering is used in the construction of the first floor and roof slabs. This is an economical options since this product can span 3m unsupported under wet concrete (saving on props) and it eliminates the need for reinforcing.

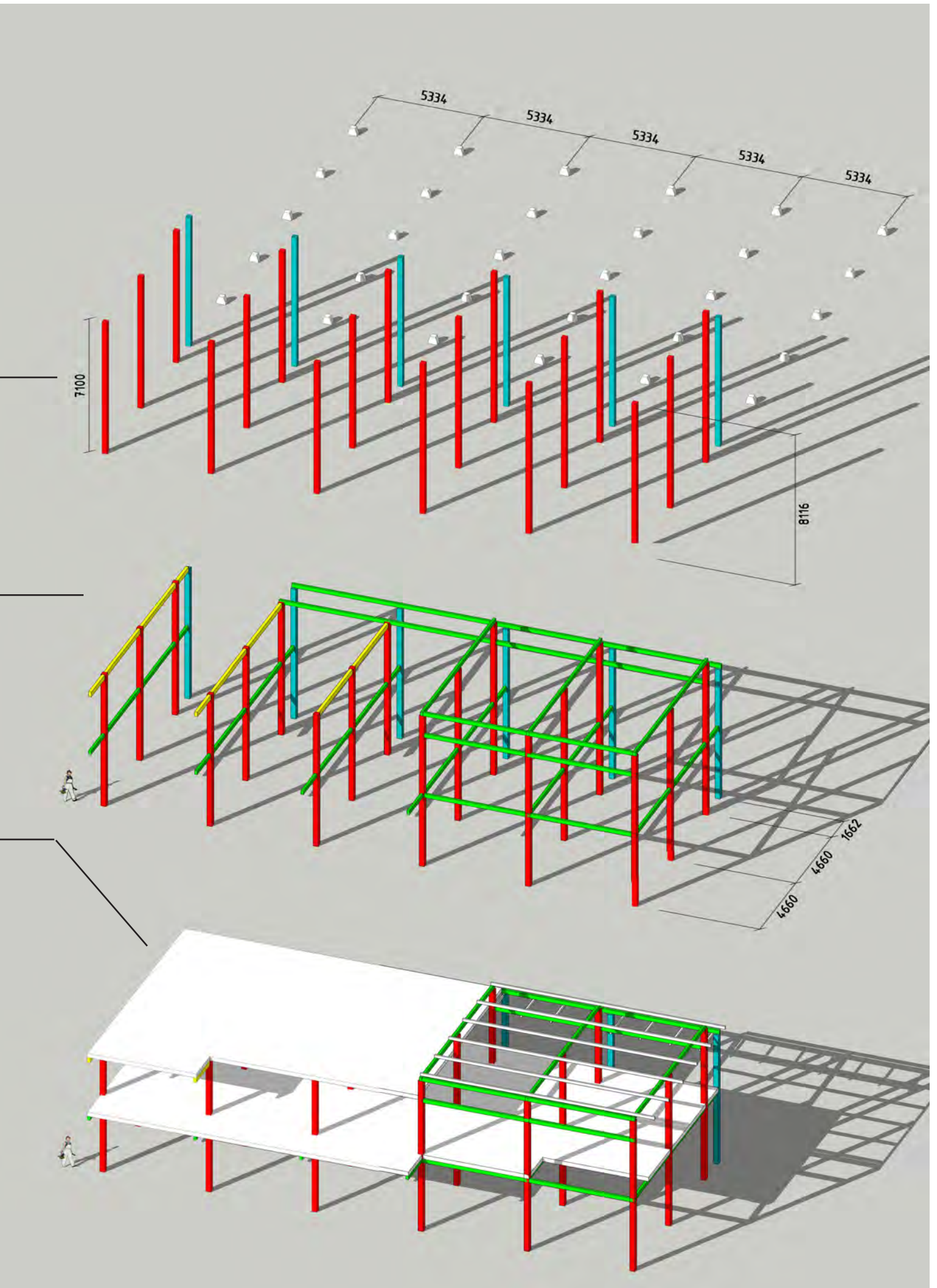
Primary structure

Secondary structure

Floors and Roofs



- 254x254 steel H-columns
- 203x203 steel H-columns
- 203x133 steel I-sections
- 254x146 steel I-sections



Right: **Figure 133** Structural system of Building 2(Author, 2017)

Below: **Figure 134** Reference plan for building 2(Author, 2017)

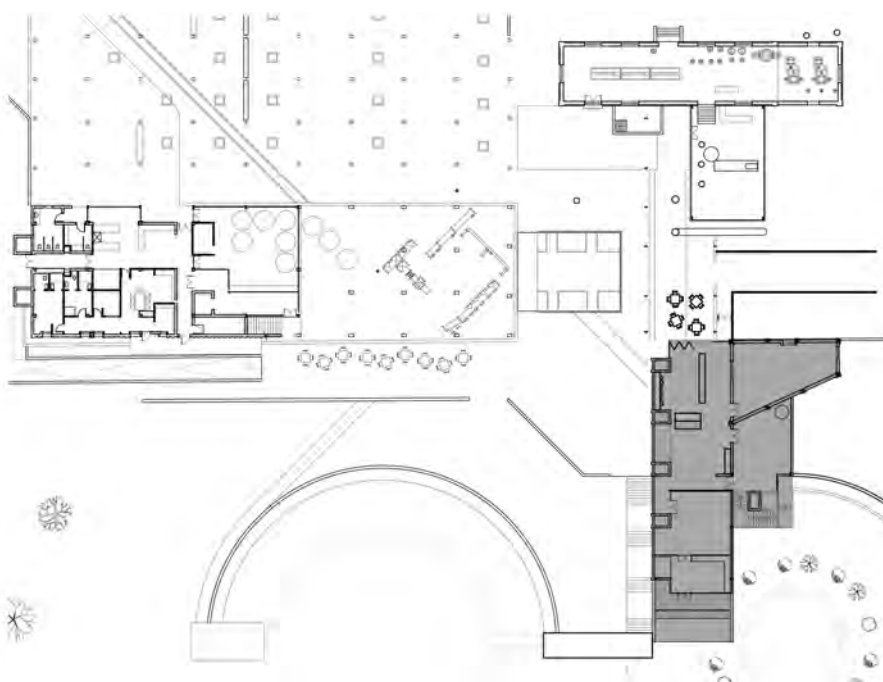
8.3.2 Structural system Building 2

Structural system

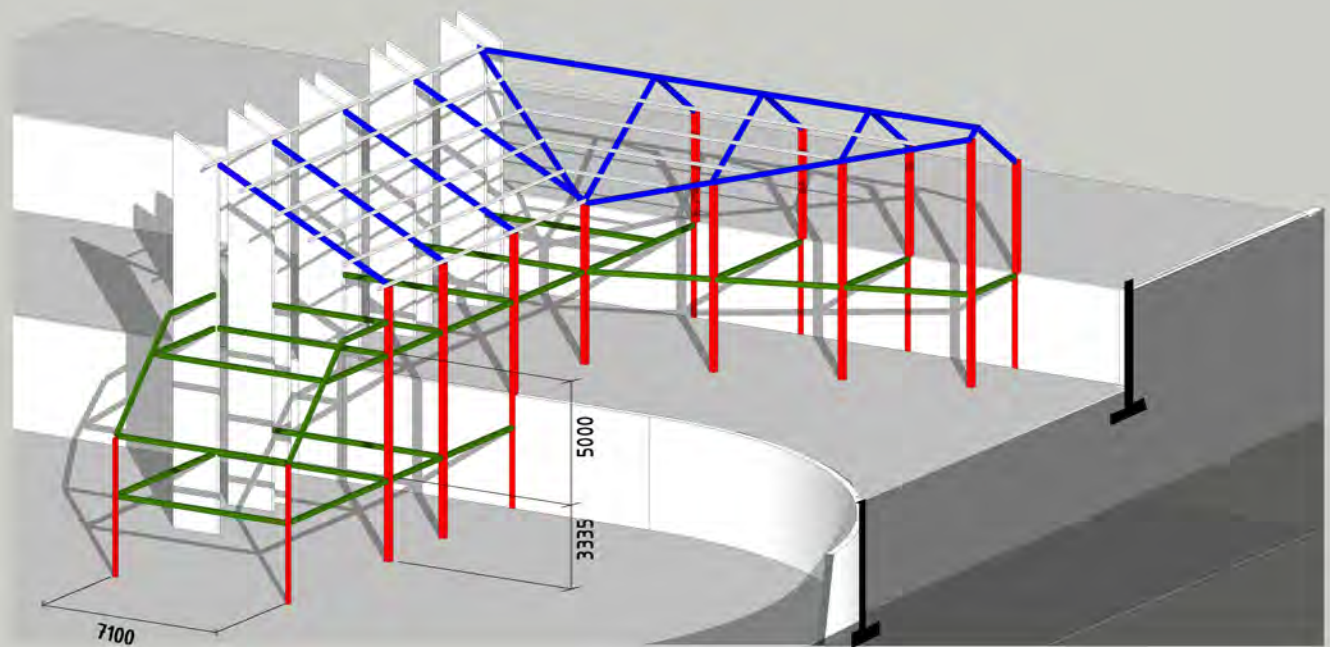
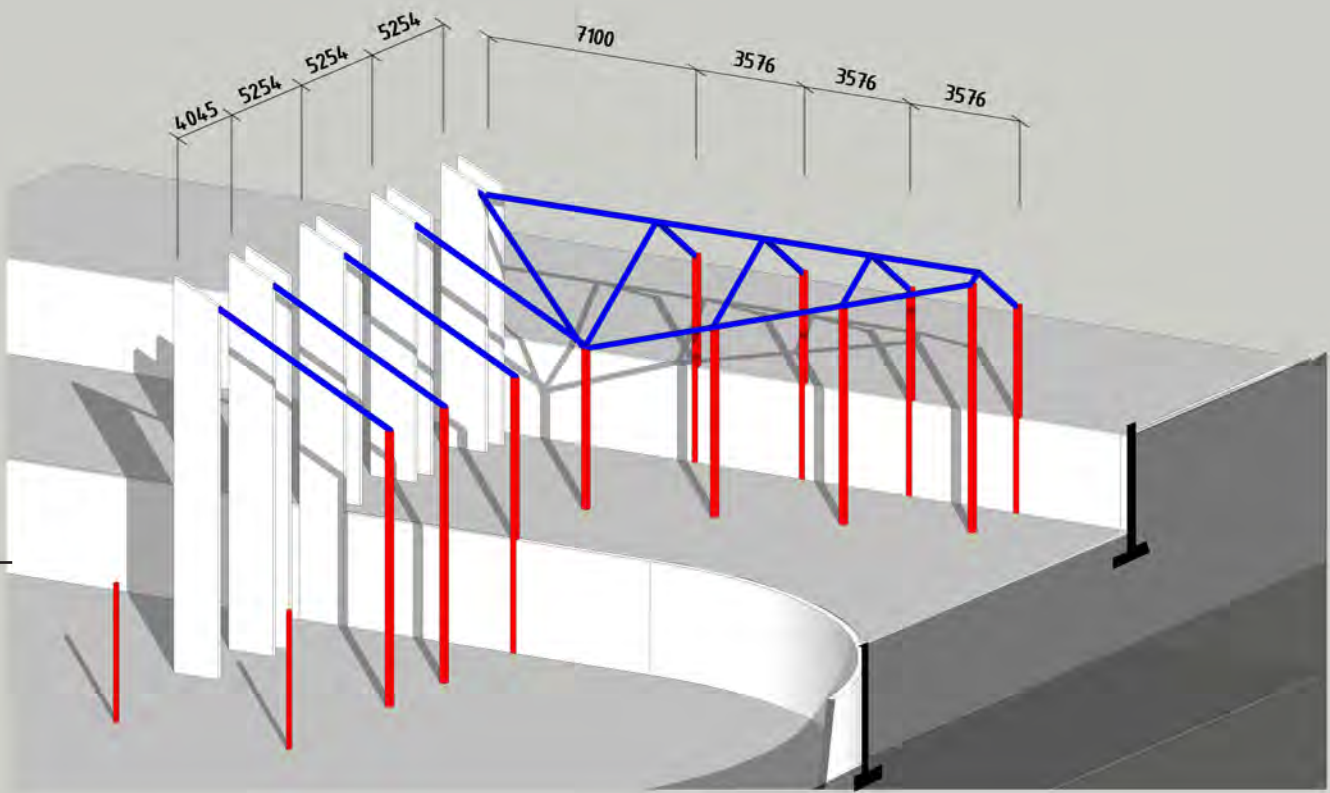
Building 2's structural system is a series of portal frames supported in some instances by 2000x200mm concrete columns, which form part of the passive ventilation strategy explained later. Steel construction also enables the building to be lifted from the ground where the building overlaps with the gas tank hole within which it partially sits. The building also makes use of permanent shuttering for reasons mentioned in Building 1's explanation.

Primary structure

Secondary structure



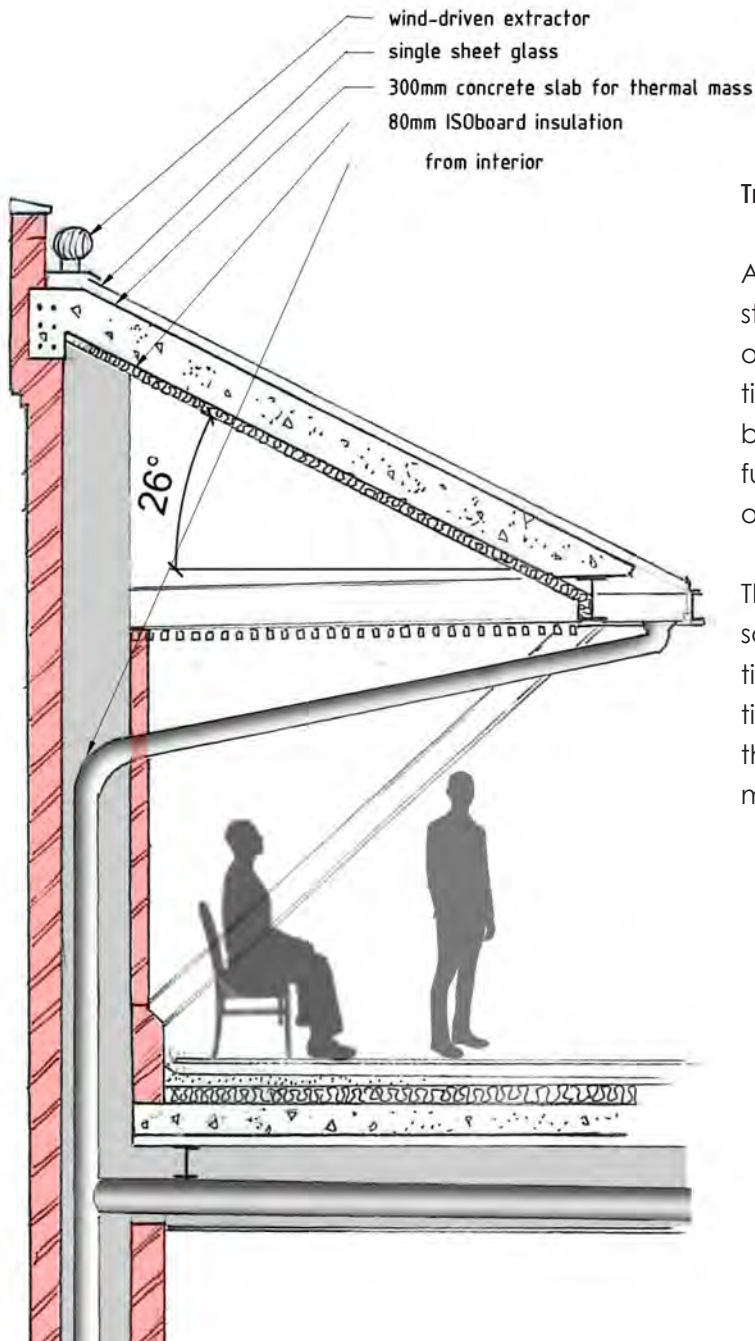
- 254x254 steel H-columns
- 203x133 steel I-sections
- 203x133 steel I-sections
- 2000x200 Reinforced concrete



Below: **Figure 135** Trombe wall detail at scale 1 to 50.

Right: **Figure 136** North-eastern elevation showing continuity between Trombe wall and external stair in elevation at scales 1 to 200 and 1 to 100

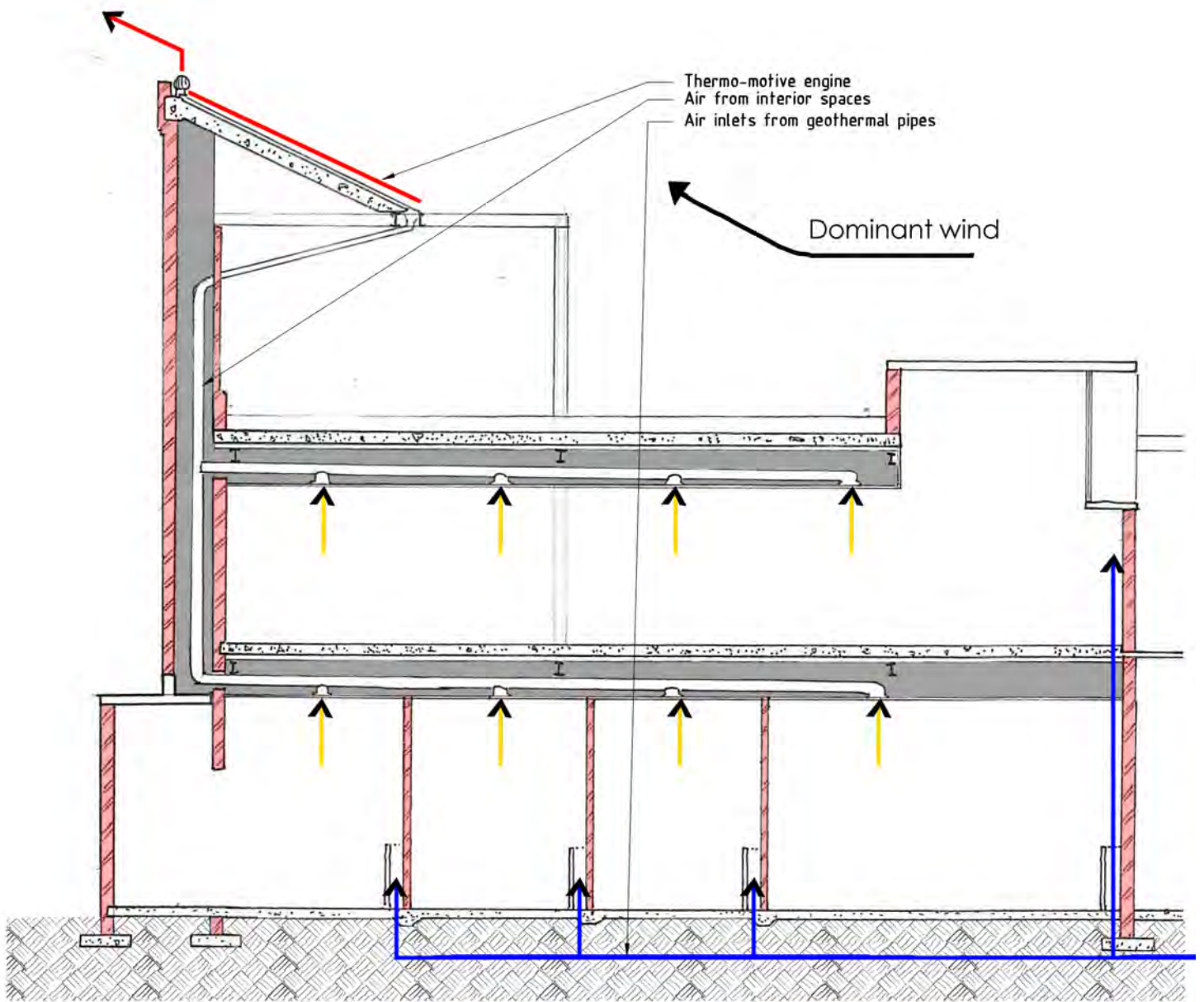
8.4.1 Passive ventilation Building 1



Trombe assisted stack

As can be seen in Figure 136, the Trombe assisted stack fulfills the practical role of drawing stale air out of the building and the aesthetic purpose of continuing and ending the diagonal geometry initiated by the stair. This aesthetic aim is especially successful when employed at a sufficient height to form an overhang for a bench as can be seen in Figure 135

The Trombe wall is slanted to an angle of 26° since solar radiation would be optimized if the system is tilted to the same angle as the latitude of the location of the building. Geothermal pipes installed under the building will supply the interior space with air at a moderate temperature.

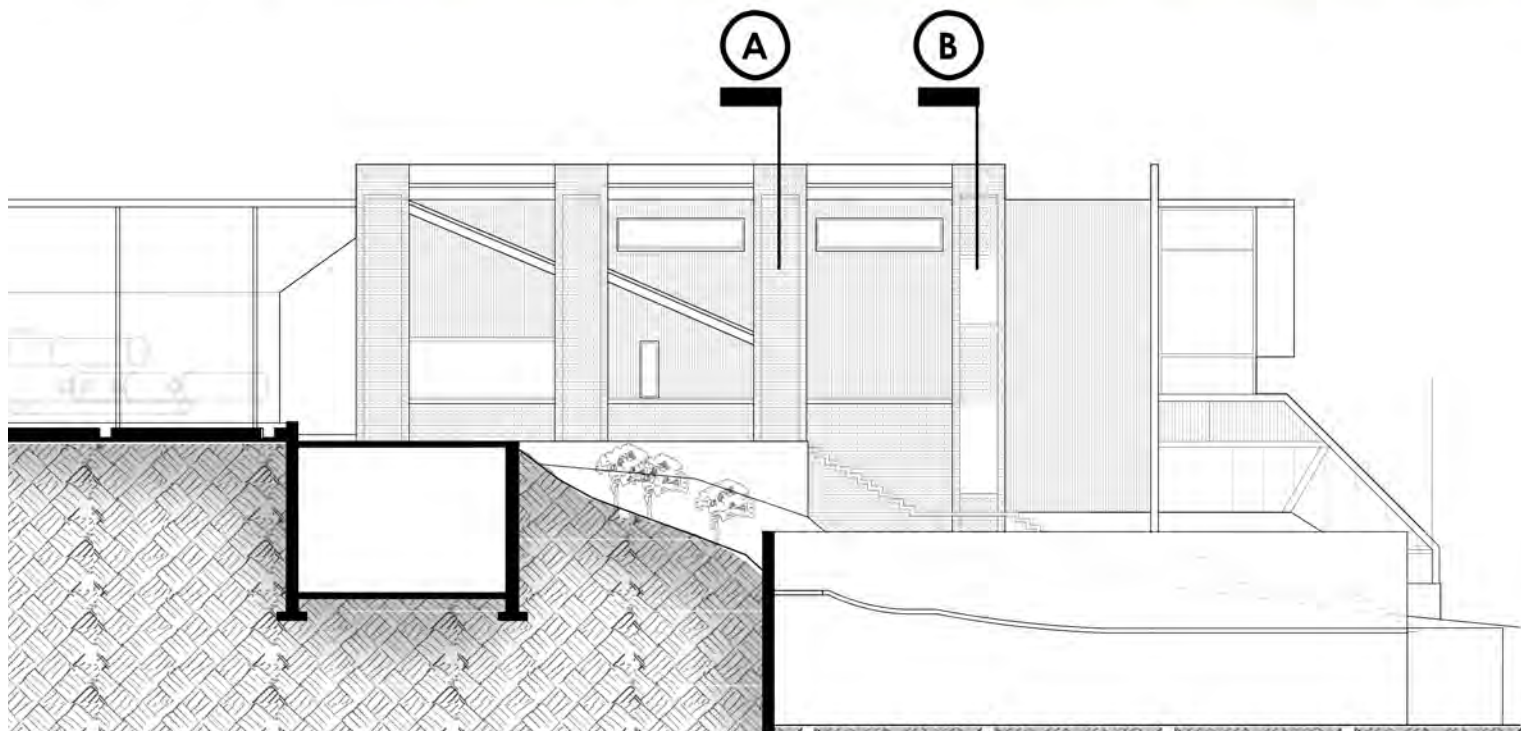
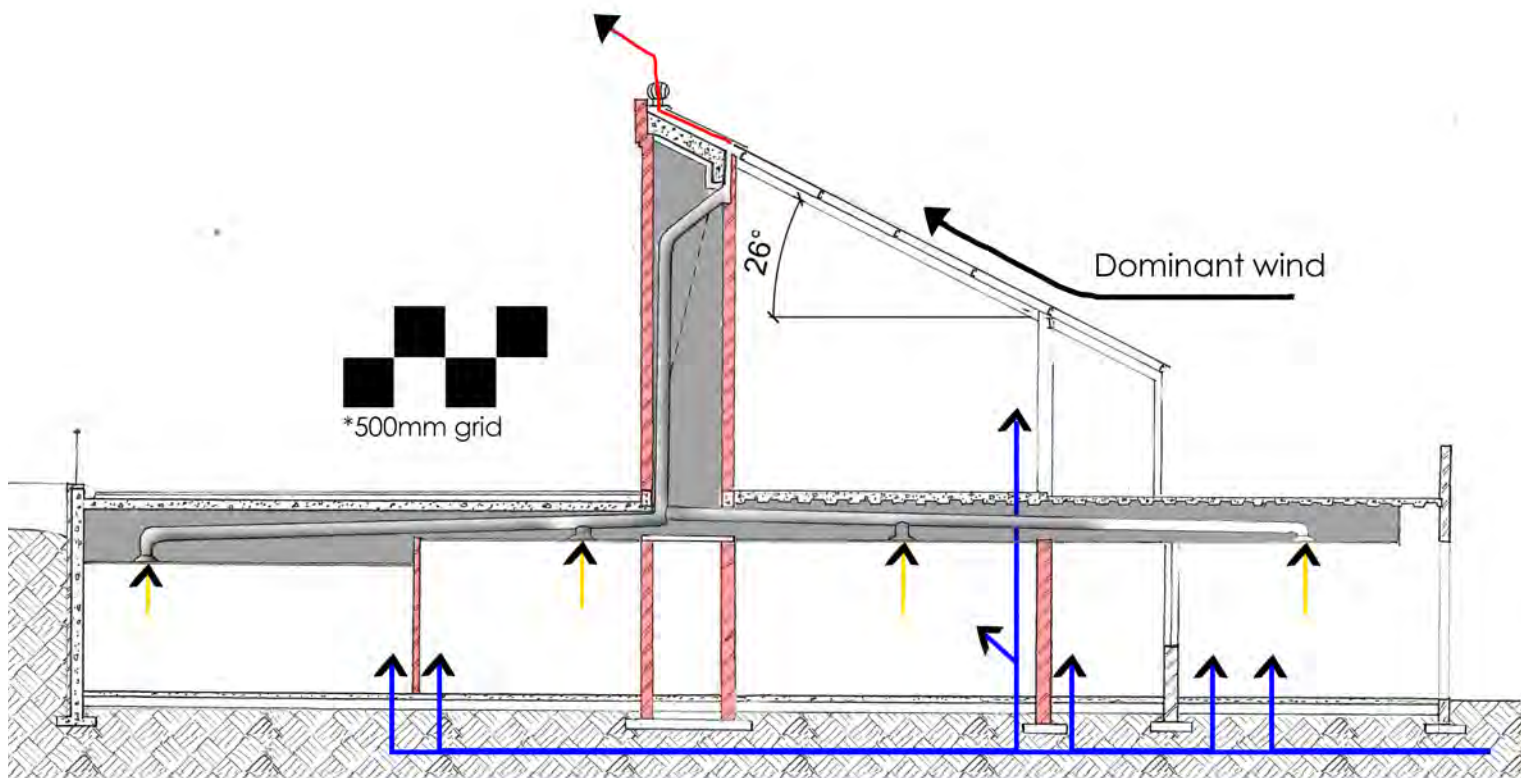


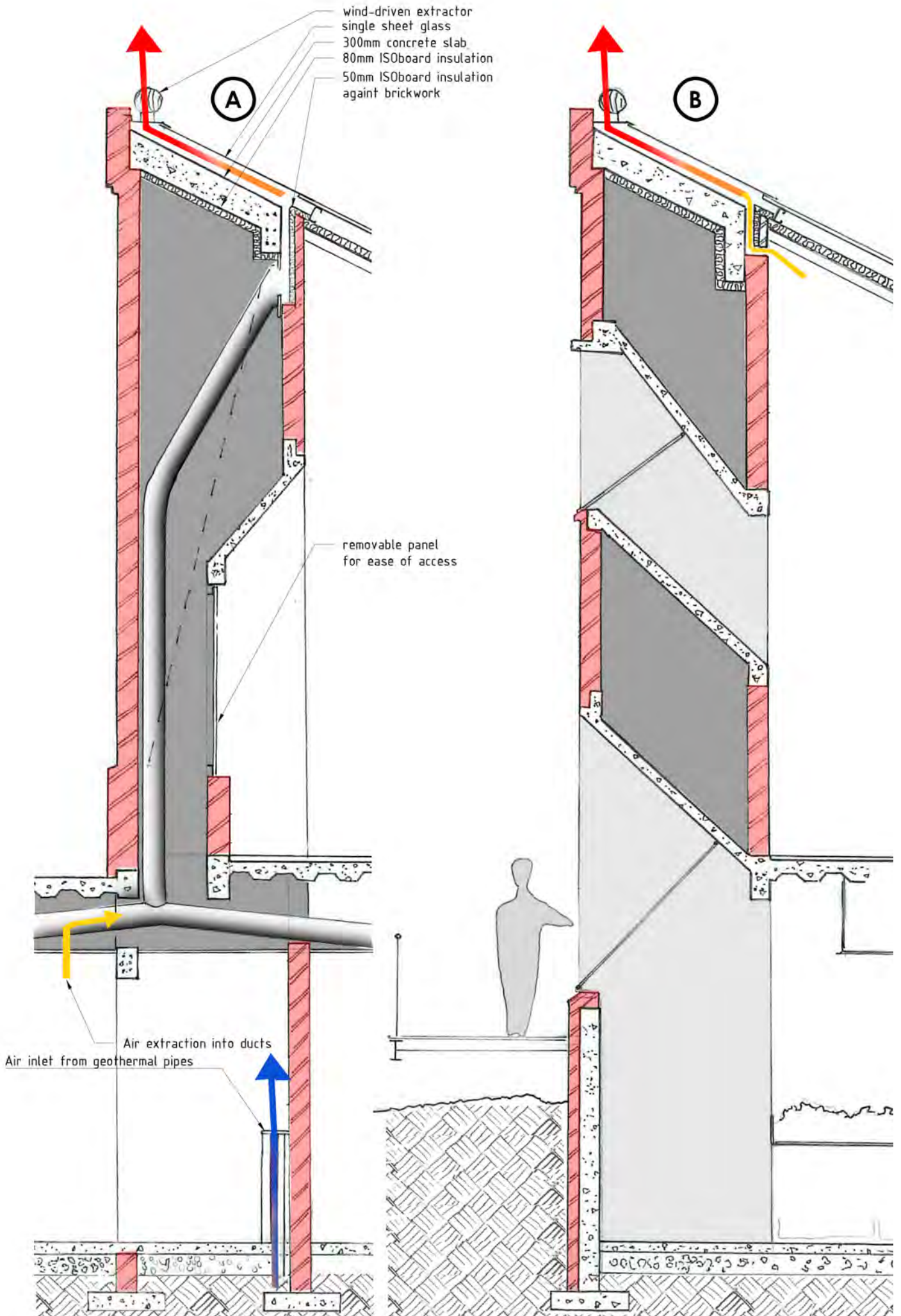
Below: **Figure 137** Building 2 cross section showing passive ventilation strategy at scale 1 to 100

Bottom: **Figure 138** South-eastern elevation of building 2 showing Trombe wall system as implemented in the facade

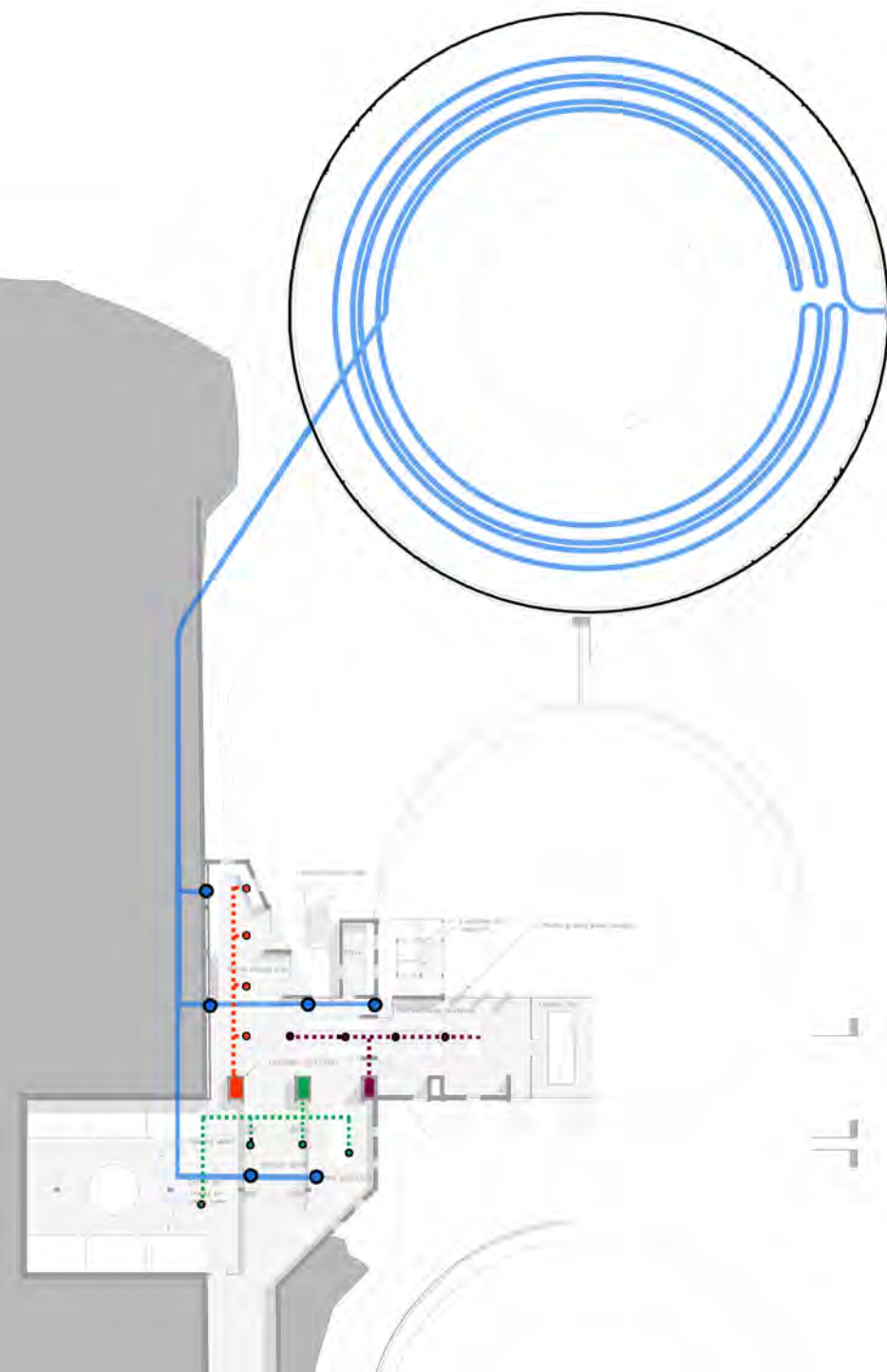
Right: **Figure 139** Trombe wall detail at scale 1 to 50 showing possibilities of implementation at either level.

8.4.2 Passive ventilation Building 2





8.4.3 Geothermal pipes and ventilation strategy



The implementation of geothermal earth tubes and Trombe assisted stack ventilation

Volume to ventilated: 1250 cubic meters
 air change rate required: 15 air changes/hour (industrial)

Precedent study:

volume to be ventilated: 600 cubic meters
 air change rate required: 8 air changes/hour
 length of pipe installed: 180m

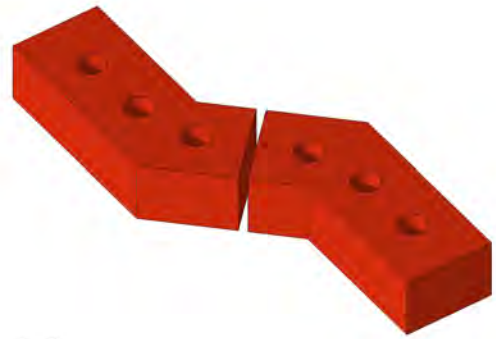
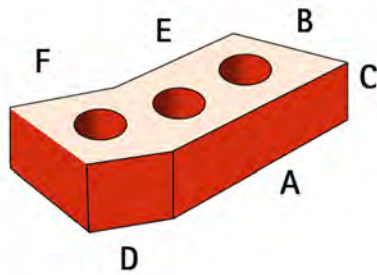
For this scheme it is proposed that there be installed 500 meters of geothermal earthtubes to assist with the ventilation of the submerged service level. Typically, the installation of the amount of pipes below ground require severe excavations over large surface areas. For a site as sensitive as the Gas Works it was decided to lay the pipes within the earth mound proposed for gas tank no. 3.

Service level plan. Scale 1:200

(showing geopipes path and overhead ventilation ducts connected to Trombe assisted solar stack)

Figure 140 The implementation of geothermal earth-tubes (Author, 2017)

- A 222mm
- B 106mm
- C 73mm
- D 106mm
- E 178mm
- F 57mm

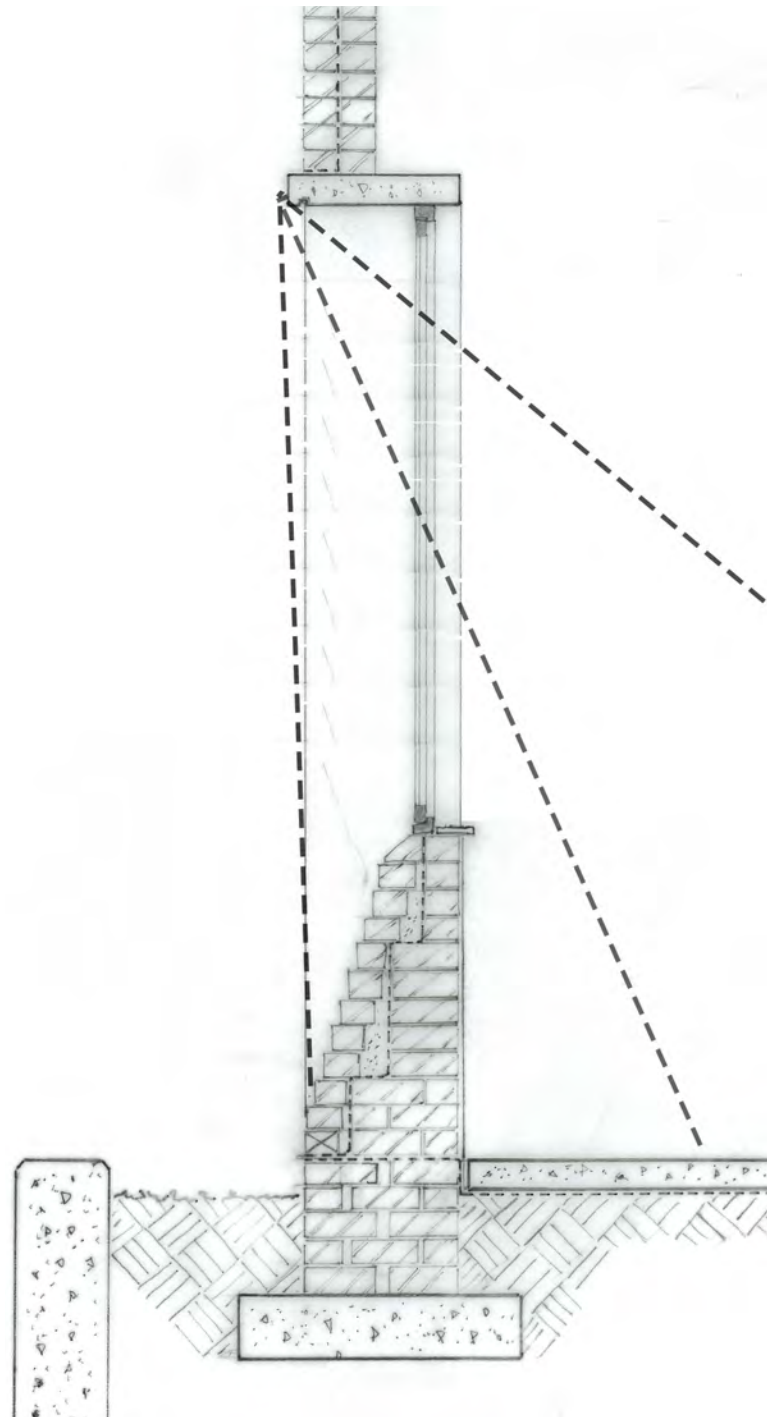


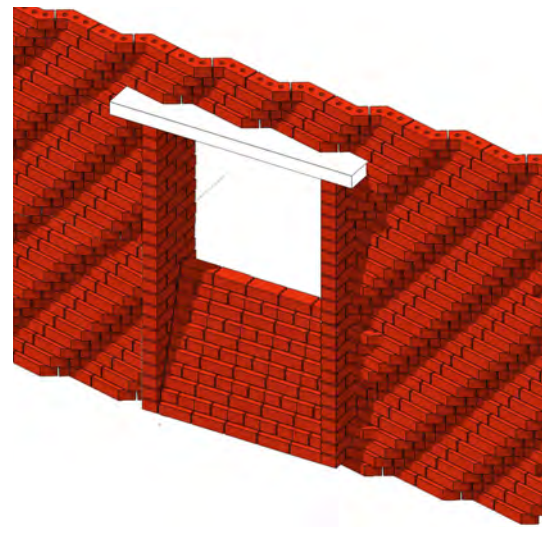
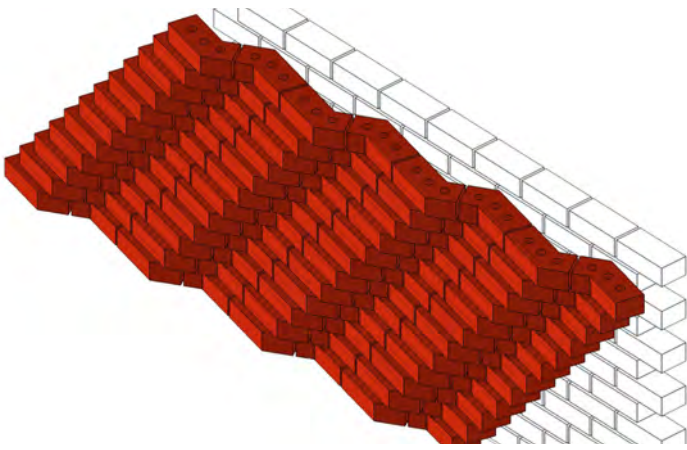
8.5 Construction detailing

Utilizing brick in new ways

As mentioned on the previous page, using brick in a new way creates a distinction between the rigidity of the large scale brick facades constructed in stretch-bond and the new building. By using the external angle 45 brick on the north-eastern facade, not only can the front facade be read in conjunction with the front facade of Retort No. 2, but the diagonal protrusions created by repeating the brick will create different variations of shadow patterns on Building 1's facade throughout the day.

Although the existing brickwork on site is typically employed as a thin skin wrapped around the building structure, the facade of building 1 aims to realize more of the potential of the material than being a mere envelope. By creating more depth in the facade, the brickwork is also used as a means of solar control.

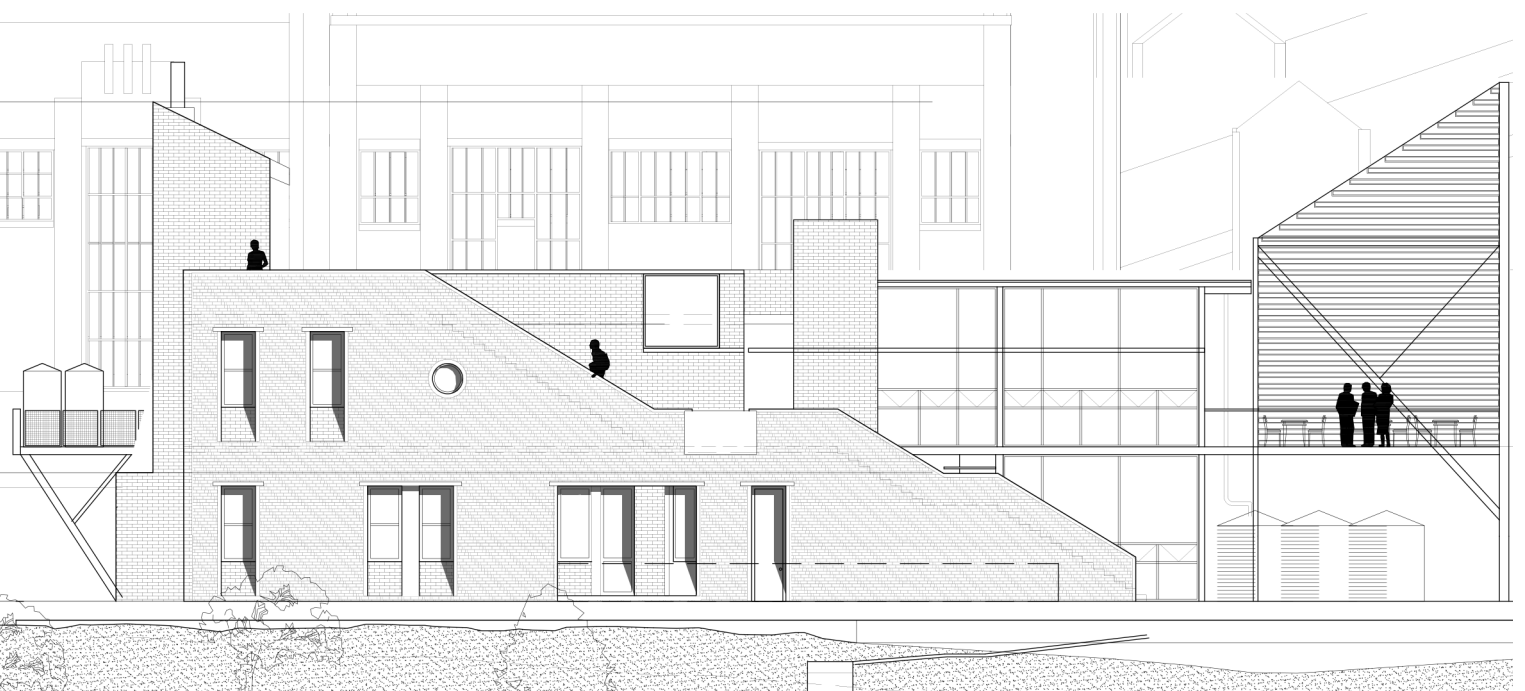




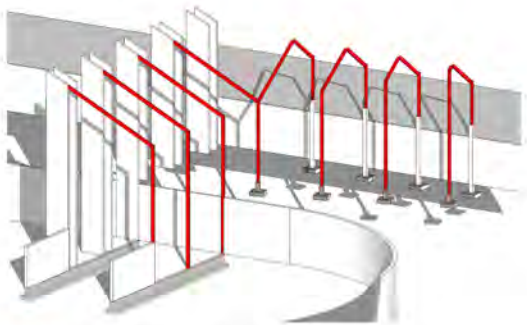
Top: **Figure 141** The implementation of Corobrik external angle 45 brick into building facade (Author, 2017)

Left: **Figure 142** Recessed brickwork as a means of solar control (Author, 2017)

Right: **Figure 143** Recessed brickwork and the effect on building 1's facade (Author, 2017)

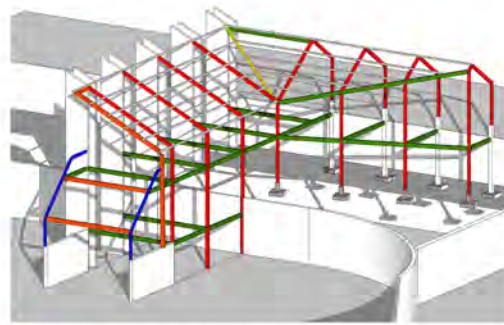


PRIMARY STRUCTURE



- 254x146x37 steel I section frames
- Reinforced concrete

SECONDARY STRUCTURE



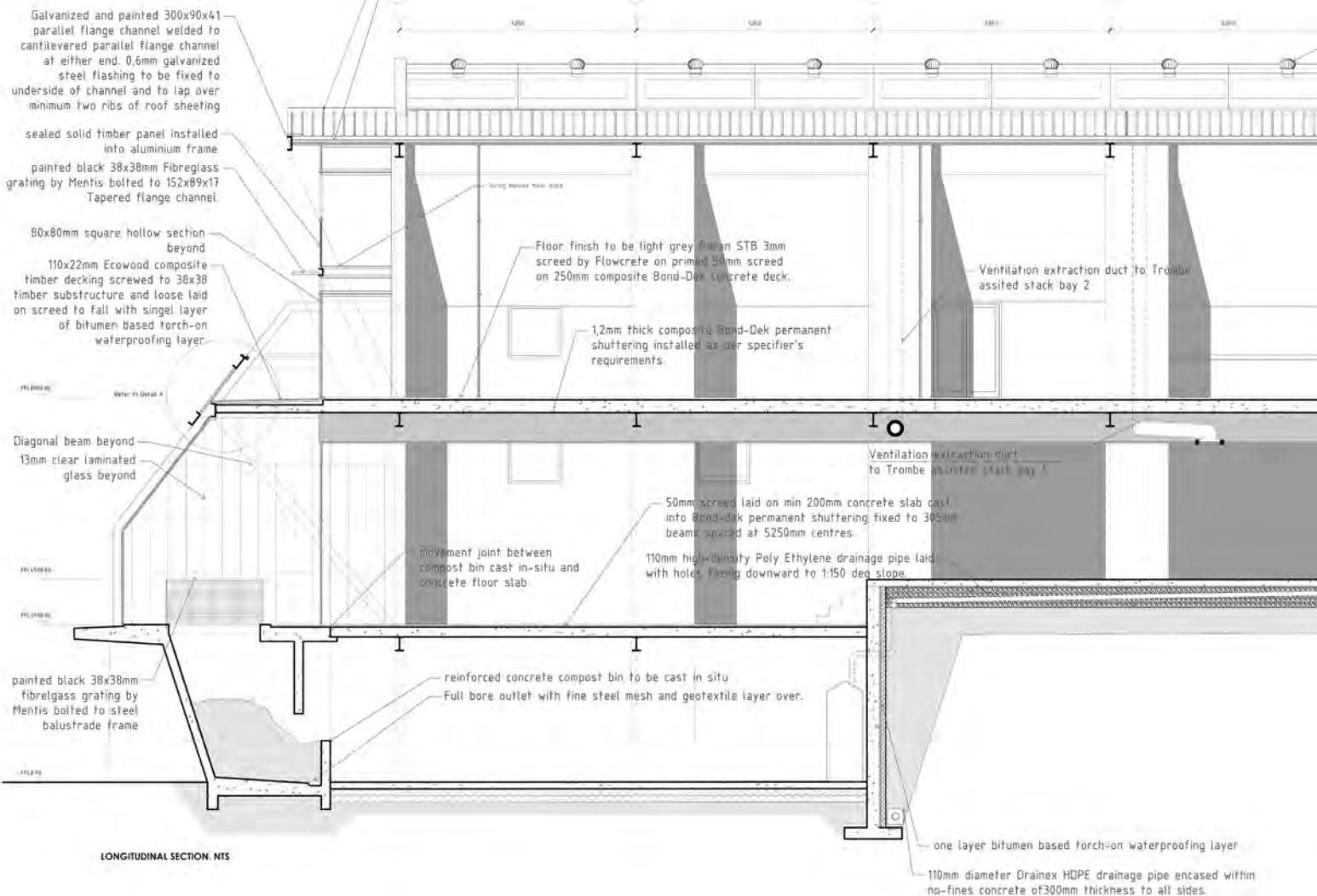
- 300x90x41 parallel flange channels
- 305x165x40 steel I-sections
- back to back 300x90x41 parallel flange channels
- 200x146 steel I section



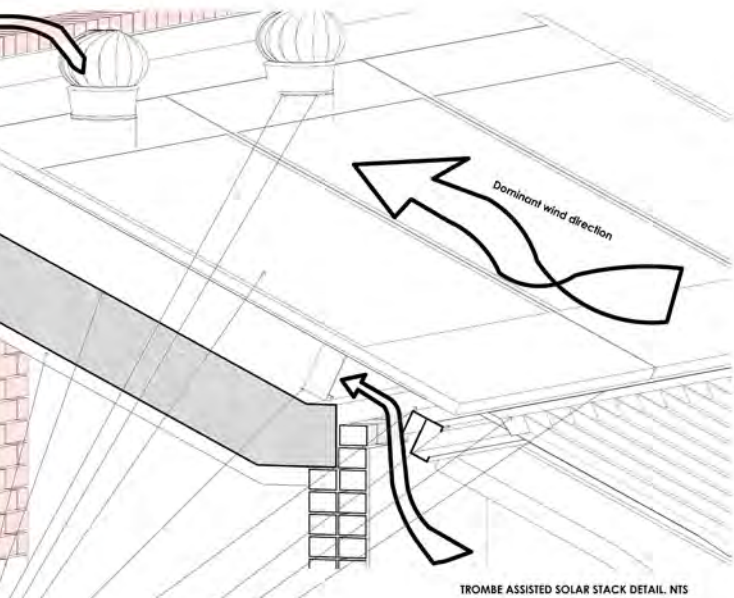
- 80mm ISOboard insulation glued to underside of concrete slab
- 300mm reinforced concrete slab
- Stainless steel flashing to lap over glass frame
- Whirly bird
- 13mm laminated single clear glass
- 200x50 mild steel angle bolted to concrete slab
- Aluminium counter flashing fixed to side of lipped channel and from above. To be fixed through serrated closer
- 150x75mm lipped channel
- Serrated closer
- Sitotone seal

Roof sheeting to be concealed fix klip-lok 700 o.5mm thick light industrial Z450 spelter galvanized steel sheeting and accessories by Brownbuilt fixed to 150x75mm cold formed lipped channels at 1750mm centres.

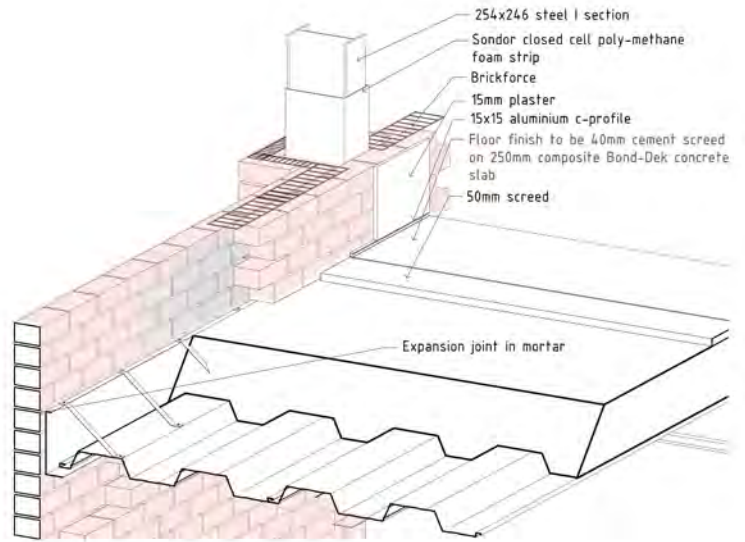
Insulation to be 80mm ISOboard installation panels installed in between lipped channels underneath vapour barrier.



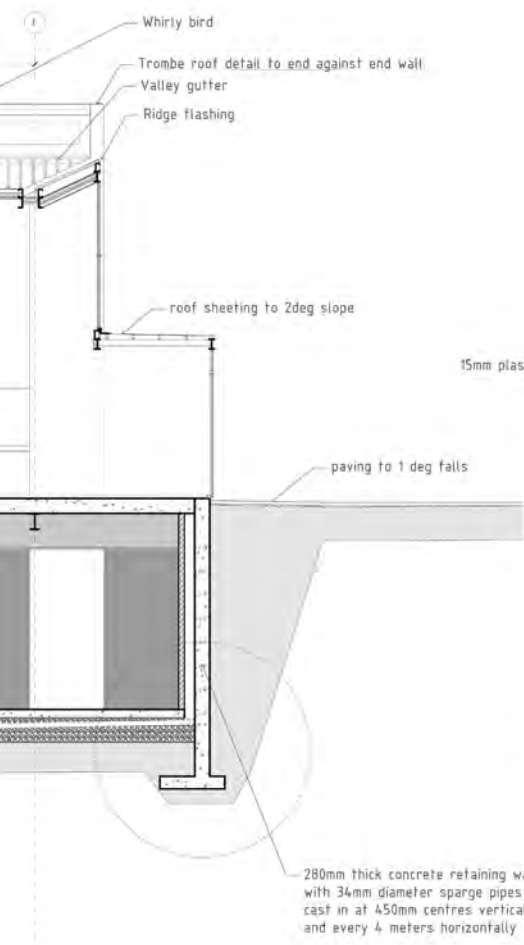
LONGITUDINAL SECTION: NTS



TROMBE ASSISTED SOLAR STACK DETAIL. NTS

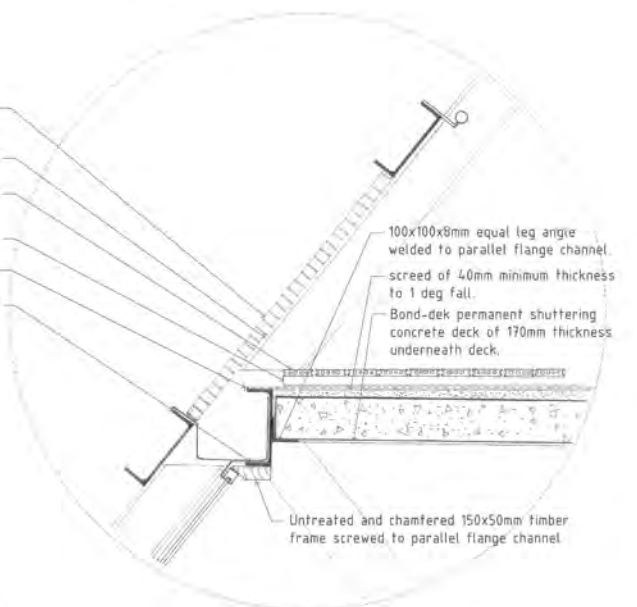


WALL TO FLOOR CONNECTION OF MUSEUM. NTS



280mm thick concrete retaining wall with 34mm diameter sparge pipes cast in at 450mm centres vertically and every 4 meters horizontally

- 38x38mm Fibreglass grating to Dark Grey colour by Mentis bolted at top and bottom end to parallel flange channels at 1000mm centres.
- black painted 203x133x25mm steel I section beyond
- 220x22mm composite timber decking by Ecowood installed with Ecoclips screwed to 38x38mm timber batten substructure as per suppliers specification.
- 38mm timber batten substructure laid onto waterproofing membrane
- 1 layer torch-on bitumen based waterproofing
- 100x300mm parallel flange channel

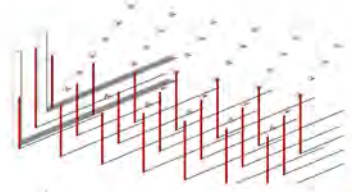


DETAIL A. NTS

- 32mm dia. polyethylene sparge pipes cast into reinforced concrete retaining wall at 450mm centres.
- 15mm plaster. 10mm mitred joint to be left above chamfered screed
- Floor finish to be 3mm Epoxy Self-Leveling on primer on min. 50mm screen on 250mm composite Bond-Dek concrete deck. Epoxy mixture to be raked after pouring using a 6mm notched trowel and spread evenly at a thickness of 3mm. Mixture to be de-aerated and leveled with a spiked roller for 20 minutes after application.

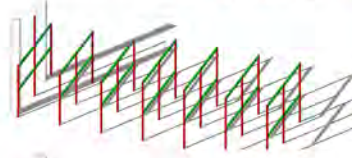
- concrete floor slab of minimum 150mm thickness.
- 250micron polyolefin damp proof membrane
- polycover by Fibretex geotextile layer
- no fines concrete laid on soil to 1:150 fall of minimum 300mm thickness below drainage pipe.
- 110mm high-density Poly Ethylene drainage pipe laid with holes facing downward to 1:150 deg slope.

RETAINING WALL DETAIL. SCALE 1:10



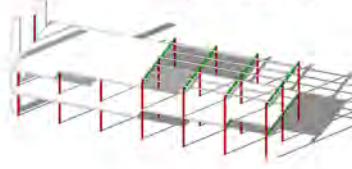
PRIMARY STRUCTURE

■ 254x146x37 steel I section frames



SECONDARY STRUCTURE

■ 305x165x40 steel I-sections



FLOOR AND TERTIARY STRUCTURE

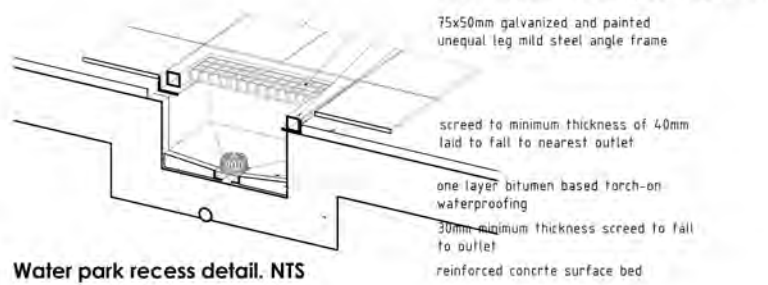
Floor: Bond-Dek composite concrete deck
Purlins: 150x75mm lipped channels

Galvanized and painted serrated flashing fixed with sheetmetal screw to roof sheeting and OSB board
150x75mm cold formed lipped channel
Dark grey painted 200x200x8mm continuous equal leg angle welded to portal frame at overlaps.
25mm OSB board fixed with countersunk screw to 200x200mm steel angle and 80x60mm mild steel angle
80x60mm mild steel angle welded to 254x146 steel I section



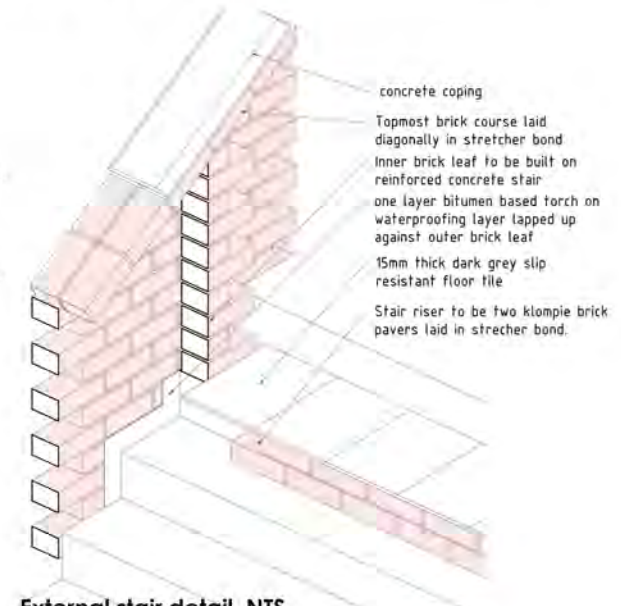
Roof detail Northern facade. NTS

Vapour barrier installed underneath roof sheeting
38x38mm fibreglass grating to Dark Grey colour by Mentis and aluminium frame bolted at top and bottom end to steel I sections.



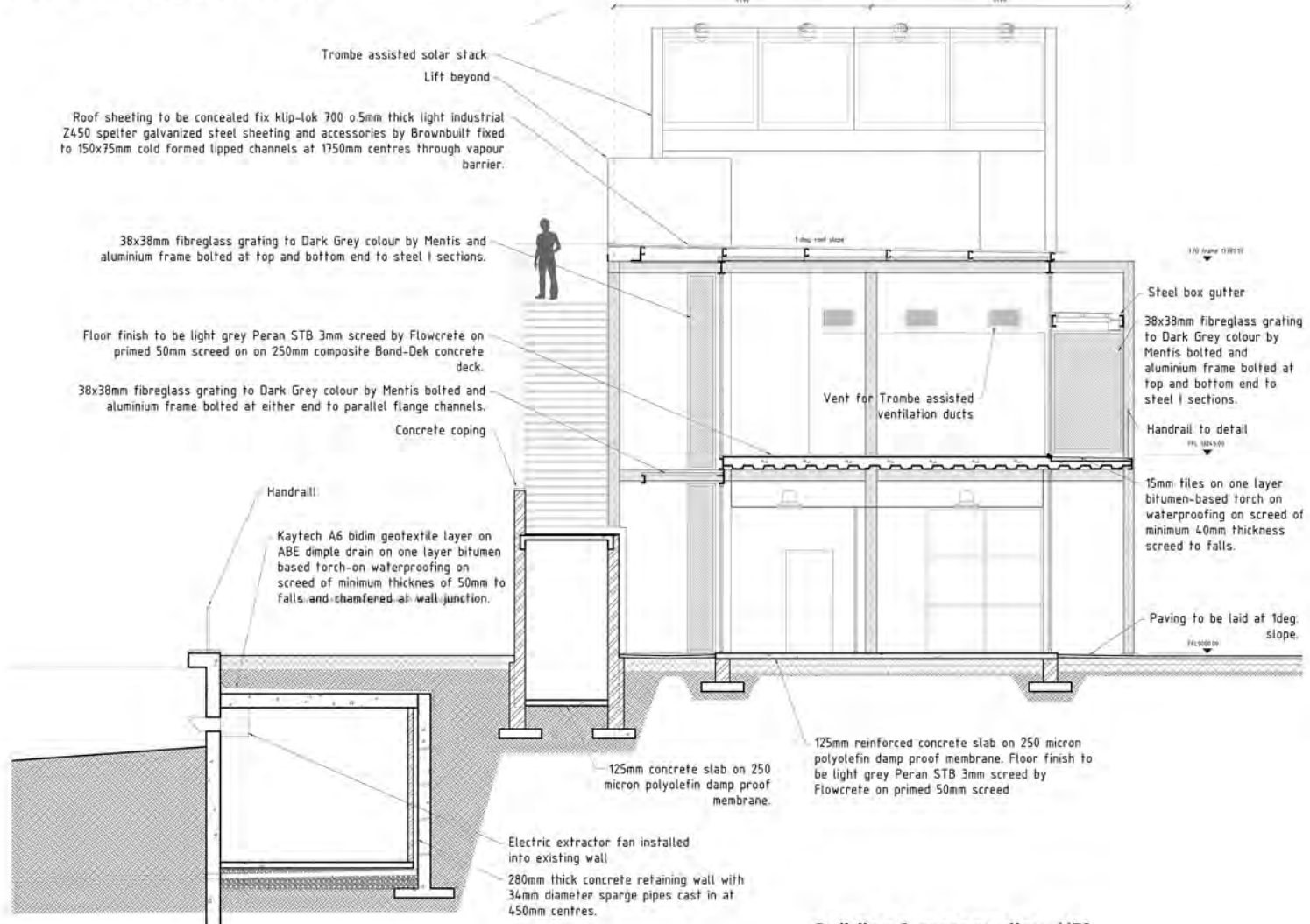
Water park recess detail. NTS

15mm thick dark grey slip resistant floor tile
38x38mm fibreglass grating to Dark Grey colour by Mentis loose laid on mild steel angle
50x50x3mm stainless steel square hollow section
75x50mm galvanized and painted unequal leg mild steel angle frame
screed to minimum thickness of 40mm laid to fall to nearest outlet
one layer bitumen based torch-on waterproofing
30mm minimum thickness screed to fall to outlet
reinforced concrete surface bed



External stair detail. NTS

concrete coping
Topmost brick course laid diagonally in stretcher bond
Inner brick leaf to be built on reinforced concrete stair
one layer bitumen based torch on waterproofing layer lapped up against outer brick leaf
15mm thick dark grey slip resistant floor tile
Stair riser to be two klompie brick pavers laid in stretcher bond.



Building 1 cross section. NTS

Trombe assisted solar stack
Lift beyond

Roof sheeting to be concealed fix klip-lok 700 o.5mm thick light industrial Z450 spelter galvanized steel sheeting and accessories by Brownbuilt fixed to 150x75mm cold formed lipped channels at 1750mm centres through vapour barrier.

38x38mm fibreglass grating to Dark Grey colour by Mentis and aluminium frame bolted at top and bottom end to steel I sections.

Floor finish to be light grey Peran STB 3mm screed by Flowcrete on primed 50mm screed on on 250mm composite Bond-Dek concrete deck.

38x38mm fibreglass grating to Dark Grey colour by Mentis bolted and aluminium frame bolted at either end to parallel flange channels.

Concrete coping

Handrall

Kaytech A6 bidim geotextile layer on ABE dimple drain on one layer bitumen based torch-on waterproofing on screed of minimum thickness of 50mm to falls and chamfered at wall junction.

125mm concrete slab on 250 micron polyolefin damp proof membrane.

Electric extractor fan installed into existing wall
280mm thick concrete retaining wall with 34mm diameter sparge pipes cast in at 450mm centres.

1:10 roof slope

1:10 (max) (1:10) 10

Steel box gutter

38x38mm fibreglass grating to Dark Grey colour by Mentis bolted and aluminium frame bolted at top and bottom end to steel I sections.

Handrall to detail
FRL 102x50

15mm tiles on one layer bitumen-based torch on waterproofing on screed of minimum 40mm thickness screed to falls.

Paving to be laid at 1deg slope.
FRL 1000 00

125mm reinforced concrete slab on 250 micron polyolefin damp proof membrane. Floor finish to be light grey Peran STB 3mm screed by Flowcrete on primed 50mm screed

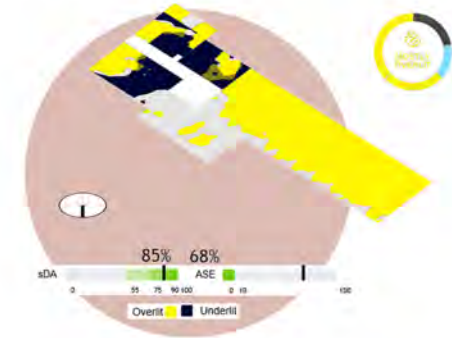
8.6 Daylighting iterations

Building 1 Southwestern Elevation prior to iterations

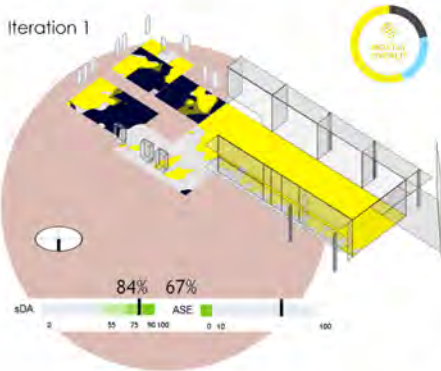


Overlit/ Underlit areas study

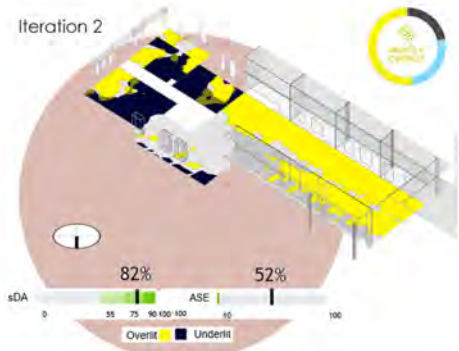
Baseline test on Building 1 ground floor



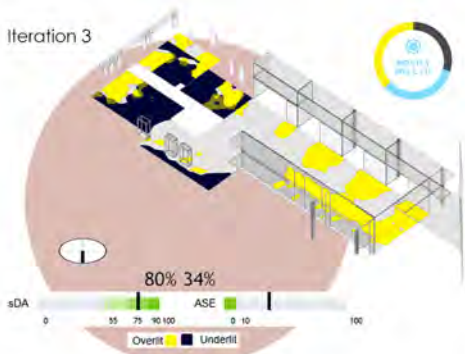
Iteration 1



Iteration 2



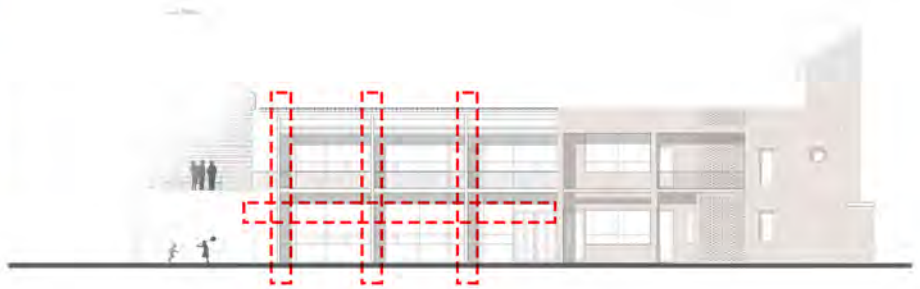
Iteration 3



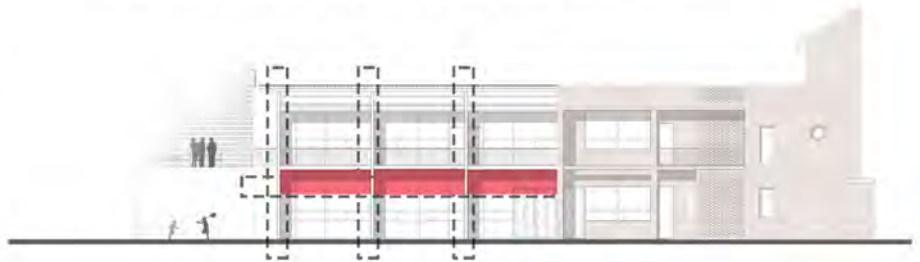
Findings

After a daylight analysis of building one was conducted, it was found that the steel and glass construction at the northern end of the building dealt poorly with overlighting in the ground floor aquaculture and first floor restaurant area. With almost the entire restaurant area being overlit, it was clear that numerous iterations would have to improve the situation.

Iteration one entailed the introduction of vertical and horizontal louvres on the Western facade between the structure and the skin of the building.



Iteration two entailed the implementation of solid infill panels in between the first floor slab and the horizontal louvres proposed in iteration 1.

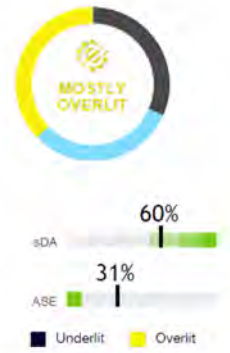
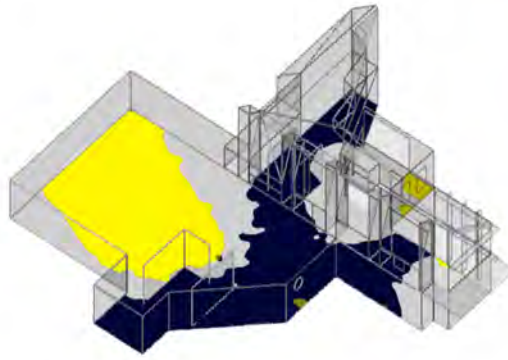
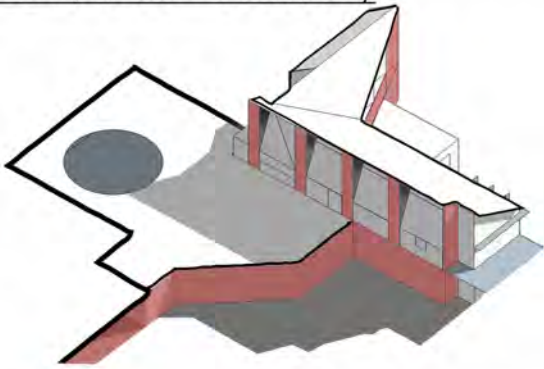


Iteration three entailed installing three vertical shading screens that each filled half a bay in the western facade. These screens could either be part of the skin or as separate entities part of the structure.

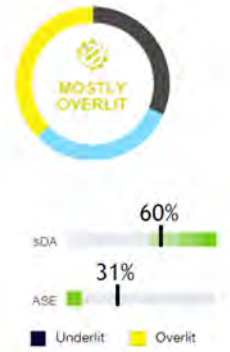
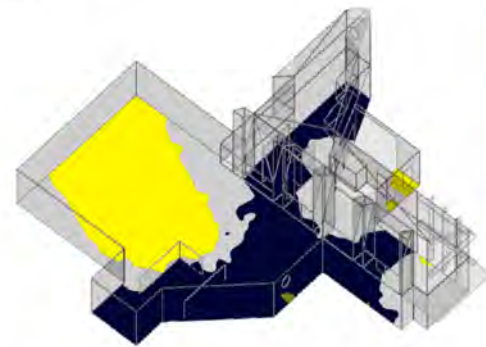


Figure 145 Building 1 baseline over/under-lit study (Sefaira, 2017 and edited by author)

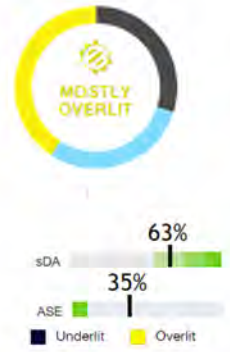
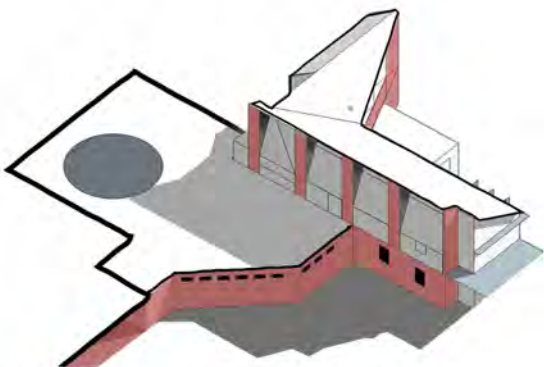
Building 2 Basement level prior to iterations
 Overlit/ Underlit areas study



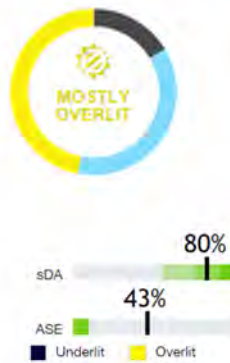
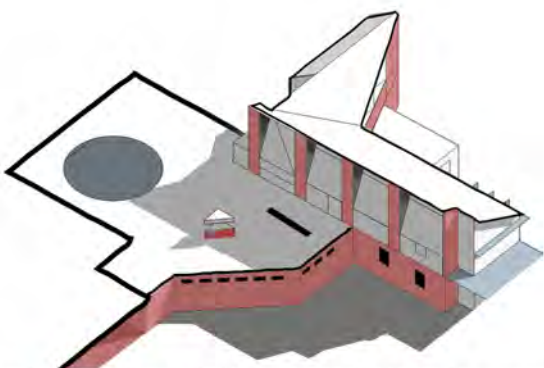
After a baseline test was conducted it was found that the basement service level was underlit. Therefore, a series of iterations sought to improve the daylighting of this floor



Iteration 1 - lower all internal non-load bearing walls



Iteration 2 - The addition of windows in the retaining wall



Iteration 3 - The addition of windows in the waste delivery area and longer linear skylights in the lookout point.

- Underlit (Less than 300lux for more than 50% of occupied hours)
- Overlit (Over 1000lux of direct light for more than 250 occupied hours per year)

Figure 146 Building 2 baseline over/under-lit study (Sefaira, 2017 and edited by author)

8.7 Rainwater harvesting calculations

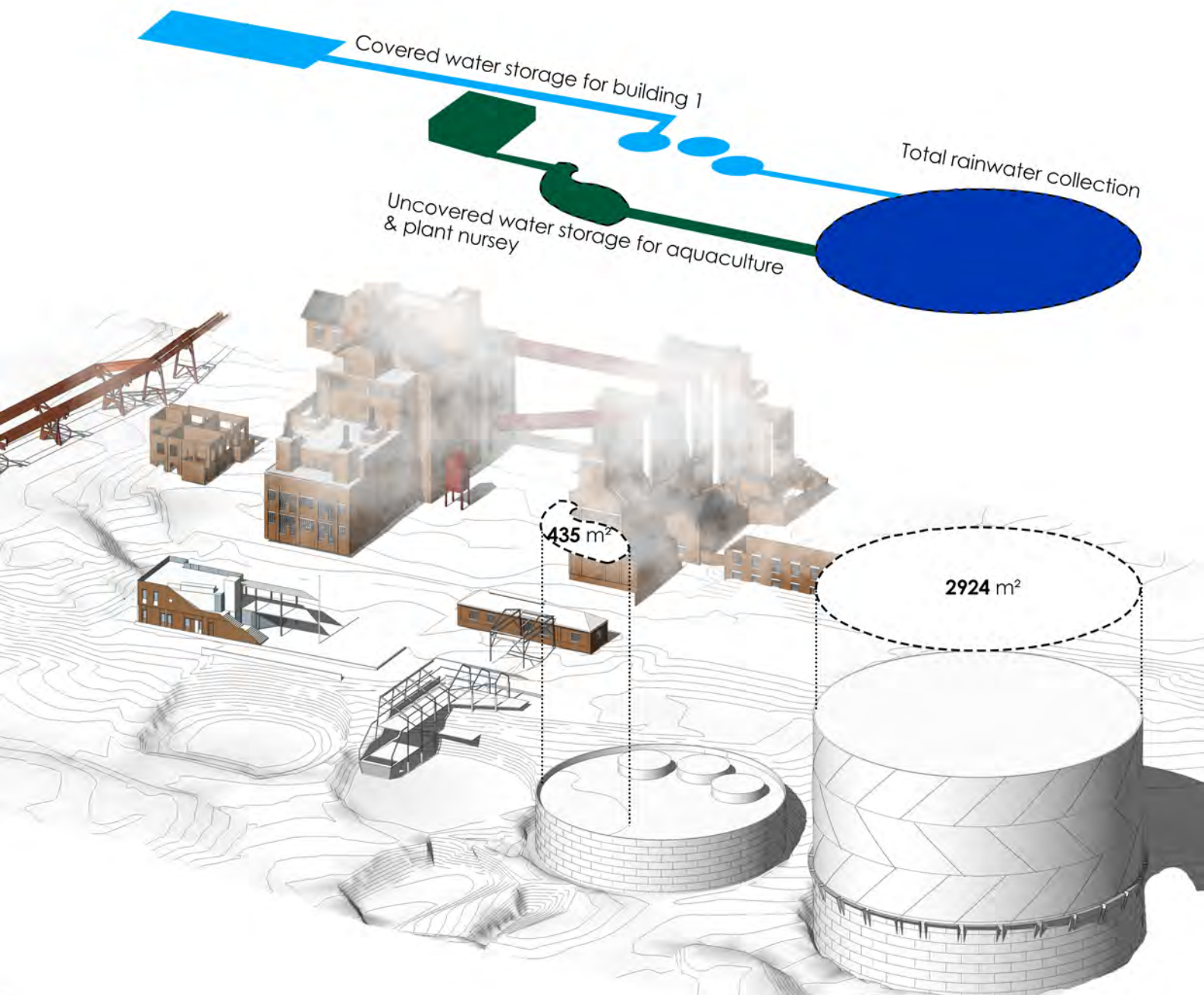


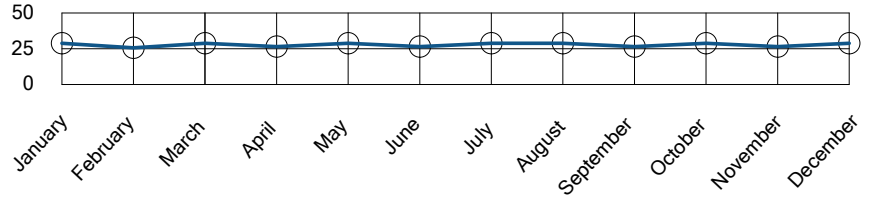
Figure 147 Rainwater harvesting strategy (Author,2017)

Table 1. Rainwater collection

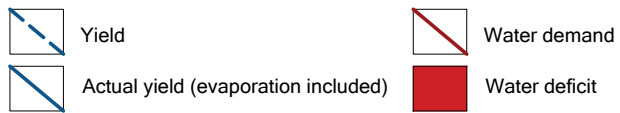
WATER DEMAND FOR APPLIANCES

Appliance	Quantity	flow rate l/minute	liter/use	Usage/day	liter/day	liter/week
public toilet	4	-	4	64	256	1536
staff toilet	2	-	4	10	40	240
Urinal	1	-	1	180	180	1080
handwash basin	6	12	1	100	100	600
shower	2	6	24	3	72	432
Dishwasher	1	-	180	1	180	1080
Kitchen basin	2	12	-	16	192	1152
TOTAL					1020	6120

WATER DEMAND (m³)

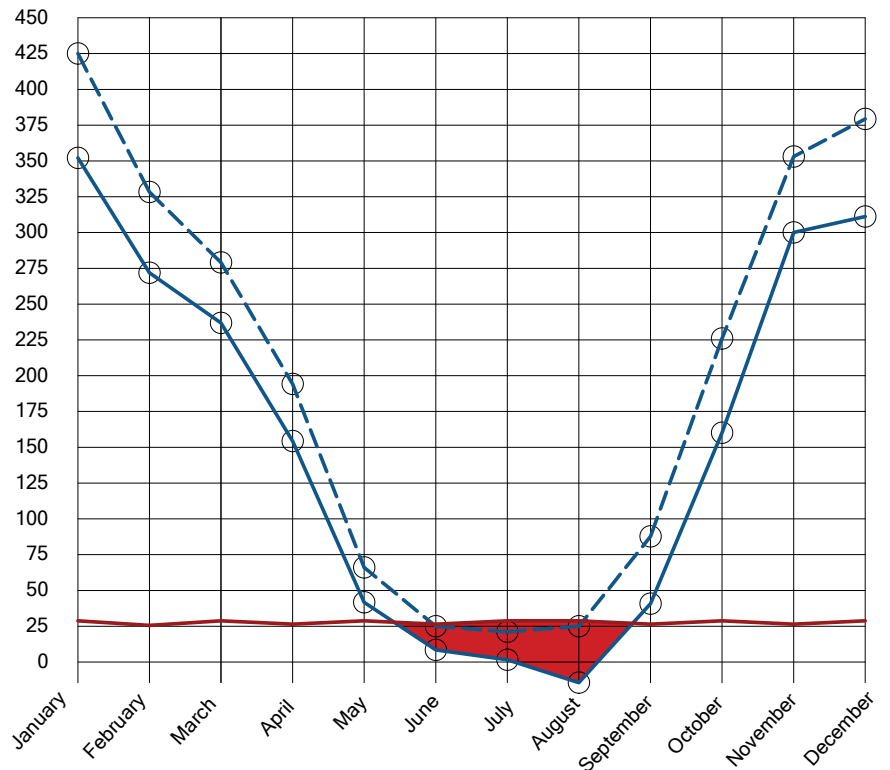


RAINWATER YIELD AND DEFICIT CALCULATION



SURFACE	Area (m²)	Runoff Coeff.
Roof	2924	0,9
Pond	434,8	1
	3358,8	0,91

MONTH	Ave. rainfall (mm)	Yield (m³)
Jan	139	426,23
Feb	108	331,17
March	91	279,04
April	62	190,12
May	21	64,39
June	9	27,60
July	7	21,46
Aug	8	24,53
Sept	28	85,86
Oct	74	226,91
Nov	118	361,84
Dec	125	383,30
		2422,46



Storage volume required= 40m³ x 3 months = 120m³. Therefore, the dam proposed in the foundation of Gas tank 3 with an area of 434 m² and average depth of 1,5 m will suffice.

Bibliography

- Agriculture, G. 2017. *Agriculture at a crossroads*. <http://www.globalagriculture.org/report-topics/water.html> (Accessed 26 April 2017)
- Baker, M. *Turbine hotel in Knysna, South Africa*. <http://www.stayreview.com/turbine-hotel-in-knysna-south-africa/> (Accessed 20 May 2017)
- City of Johannesburg. Department of Development Planning. 2016. *Spatial Development Framework 2040*. www.sapra.org.za/docs/Johannesburg%20Spatial%20Development%20Framework%202040.pdf (Accessed 27 July 2017).
- Crawford, M. 2012. Everyday Agriculture. In: T. Haas, ed. *Sustainable Urbanism and Beyond: Rethinking cities for the future*. New York: Rizzoli International Publications, p. 169.
- Garnham, HL. 1985. *Maintaining the Spirit of Place*. Mesa: PDA Publishers Corporation.
- ICOMOS, 2003. *The Nizhny Tagil Charter for the Industrial Heritage*. <https://www.icomos.org/18thapril/2006/nizhny-tagil-charter-e.pdf> (Accessed 23 September 2017)
- Georem International. 2006. *Soil Vapor Survey and Soil Sampling*, Pinegowrie: GeoRem International.
- Krinke, R. 2001. Overview: design practice and manufactured sites. In: N. Kirkwood, ed. *Manufactured Sites : Rethinking the Post-Industrial Landscape*. London: Spon Press, pp. 125-129.
- Latz, P. 2001. Landscape Park Duisburg-Nord: the metamorphosis of an industrial site, in *Manufactured Sites : Rethinking the Post-Industrial Landscape*. London: Spon Press: p 153.
- Lauferts le Roux, M. & Mavunganidze, J. 2015. *The Johannesburg Gas Works*. 1st ed. Johannesburg: Fourthwall.
- Times Live. 2016. *SA drought not broken after driest year in history*. <http://www.timeslive.co.za/local/2016/09/08/SA-drought-not-broken-after-driest-year-in-history1b> (Accessed 26 April 2017)
- Merriam-Webster. 2017. *Palimpsest*. <https://www.merriam-webster.com/dictionary/palimpsest> (Accessed 27 July 2017).
- Millstone, E., Lang & Tim, 2003. *The Atlas of Food*. 1st ed. London: Earthscan.
- Okada, M. 2014. Industrial ruins, in J Douet Ed. *Industrial Heritage Re-tooled: the TICCIH Guide to Industrial Heritage Conservation*. Walnut creek: Left Coast Press, pp. 149-154.
- Reed, P. 2008. Beyond Before and After, in *Groundswell: constructing the contemporary landscape*. 3rd ed. New York: The Museum of Modern Art
- Strategic Environmental Focus, 2002. *Joburg Metropolitan Open Space System*. Pretoria: Strategic Environmental Focus.

- Rieder, K. 2001. Crissy Field: tidal marsh restoration and form, in: N. Kirkwood, ed. *Manufactured Sites : Rethinking the Post-Industrial Landscape*. London: Spon Press: 206-207
- Tempel, N. 2014. Post-Industrial landscapes in J Douet Ed. *Industrial Heritage Re-tooled: the TICCIH Guide to Industrial Heritage Conservation*. Editor J Douet. Walnut creek: Left Coast Press, p 142
- Unwin, S., 2015. *Twenty-five buildings every architect should understand*. 2nd ed. New York: Routledge.
- Vinnitskaya, I. 2012. *The Plant: An Old Chicago Factory is Converted into a No-Waste Food Factory*. <http://www.archdaily.com/231844/the-plant-an-old-chicago-factory-is-converted-into-a-no-waste-food-factory> (Accessed 22 August 2017)
- Vosloo, P. 2015. Commemorating industrial ruins - the case for the Tswaing salt works. *South African Journal of Art History* 30(2):32-51
- Water Footprint Network. 2017. *Water footprint of crop and animal products: a comparison*. <http://waterfootprint.org/en/water-footprint/product-water-footprint/water-footprint-crop-and-animal-products/> (Accessed 27 July 2017).
- Westergasfabriek. 2017. *History: from old energy to new energy*. <http://www.westergasfabriek.nl/en/about/history/> (Accessed 20 May 2017)
- WWF South Africa. 2014. *WWF-SA Climate Solver: Magmeal*. <https://www.youtube.com/watch?v=B-WX0Eds5z1w> (Accessed 27 July 2017)