

## THERMO-ELECTRIC ENERGY STORAGE USING CO<sub>2</sub> TRANSCRITICAL CYCLES AND GROUND HEAT STORAGE

F. Ayachi<sup>a</sup>, N. Tauveron<sup>a,\*</sup>, T. Tartièrè<sup>b</sup>, S. Colasson<sup>a</sup> and D. Nguyen<sup>c</sup>

\*Author for correspondence: [nicolas.tauveron@cea.fr](mailto:nicolas.tauveron@cea.fr)

<sup>a</sup> CEA, LITEN – DTBH/SBRT/LS2T, 17 rue des Martyrs Grenoble, 38054, France.

<sup>b</sup> Enertime, 1 rue du Moulin des Bruyères Courbevoie, 92400, France.

<sup>c</sup> BRGM Languedoc-Roussillon, 1039 rue de Pinville, 34000 Montpellier, France.

### ABSTRACT

Multi-megawatt thermo-electric energy storage based on thermodynamic cycles is a promising alternative to PSH (Pumped-Storage Hydroelectricity) and CAES (Compressed Air Energy Storage) systems. The size and cost of the heat storage are the main drawbacks of this technology but using the ground as a heat reservoir could be an interesting and cheap solution. In that context, the aim of this work is i) to assess the performance of a massive electricity storage concept based on CO<sub>2</sub> transcritical cycles and ground heat exchangers, and ii) to carry out the preliminary design of the whole system. This later includes a heat pump transcritical cycle as the charging process and a transcritical Rankine cycle of 1 – 10 MWe as the discharging process.

A steady-state thermodynamic model is realized and several options, including regenerative or multi-stage cycles, are investigated. In addition, a one-dimensional design model of the geothermal heat exchanger network is used to optimize the number of wells for the ground heat storage.

The results show the strong dependency between the charging and discharging cycles, and how the use of regenerative heat exchangers and a two-phase expander (in the charging cycle) could increase the system efficiency and lower the investment cost.

### INTRODUCTION

Organic Rankine Cycles (ORC) have been used in a wide range of applications, including geothermal, biomass or solar power plants, waste heat recovery from industrial processes or combustion engines, ocean thermal energy conversion... and a wide range of power outputs from a few kW to tens of MW. The possibility to use ORC to produce electricity from heat that has been previously stored as a large-scale electricity storage technology remains more confidential but has been the subjects of recent studies [1].

As it is well-known, the massive integration of intermittent renewable energy production generates new challenges for the supervision and regulation of electric grids. The use of flexible but carbon-intensive technologies such as gas turbines has been the main solution in order to ensure the balance between demand and supply, maintaining grid frequency and power quality. However, large-scale electricity storage is a promising alternative with a much lower environmental impact. In addition, it would enable a decentralized access to electricity and lower

the dependency on fossil fuels. If storage is still expensive today, it could become increasingly viable as the price of carbon rises.

Several technologies exist or are under development for large-scale energy storage. Pumped Hydro Storage (PHS) is the most common one, accounting for more than 99% of the worldwide bulk storage capacity, representing around 140 GW over 380 locations [2]. When there is an excess of power supply, water is pumped to an upper reservoir, from where it can be discharged to drive a turbine when power demand is high. Reported roundtrip efficiencies are typically between 70% and 85%. Despite having a long lifetime and being the most cost-effective energy storage technology, these systems have a low energy density and require the construction of large reservoirs, leading to a high environmental impact. In addition, the most suitable locations have already been used in developed countries. Other possibilities would be to include pre-existing dams or the ocean, as in the 30 MW Yanbaru project in Japan [3].

In a Compressed-Air Energy Storage (CAES) system, ambient air is compressed and stored underground. Reported roundtrip efficiencies are around 50%. The capital cost of CAES power plants is competitive with PHS and their power output can reach hundreds of MW. In contrast to PHS, only 2 CAES power plants exist in the world: a 290 MW plant in Huntorf, Germany (1978) [4], and a 110 MW plant in McIntosh, USA (1991) [5]. A much higher efficiency of up to 70% could be achieved by storing the heat of compression before the pressurized air is sent to the cavity [6-7]. This Advanced Adiabatic CAES (AA-CAES) technology is still under development. As for PHS, CAES systems require very specific sites and cannot be installed everywhere.

Thermo-electric energy storage (TEES) is a promising alternative to existing technologies that would allow widespread and large-scale electricity storage. It has a high energy density and is independent from geological or geographical constraints, contrary to PHS or CAES. During periods of excess electricity generation, a vapor compression heat pump consumes electricity and transfers heat between a low-temperature heat source and a higher temperature heat sink. The temperature difference between the heat sink and the heat source can be maintained for several hours, until a power cycle is used to discharge the system and generate electricity during peak consumption hours.

Mercangöz [1] gave references of thermo-electric energy storage studies as old as 1924 and described the general concept of this technology, based on two-way conversion of electricity to and from heat. He stated that the main challenges of TEES are to

closely match the heat source and heat sink with the working fluid, and to find an optimum between roundtrip efficiency and capital cost. He analyzed a TEES system with transcritical CO<sub>2</sub>, hot water and ice as storage materials. The ABB Corporate Research Center [8-9] described a way to store electricity using two hot water tanks, ice storage and transcritical CO<sub>2</sub> cycles. For similar systems, Morandin [10-12] defined a design methodology based on pinch analysis and calculated a 60% maximum roundtrip efficiency for a base case scenario with turbomachinery efficiencies given by manufacturers.

Sensible heat storage with hot water tanks is often considered, since water has high thermal capacity, is very cheap and environmental-friendly. Latent heat storages based on phase change materials (PCMs) have also been widely investigated. The heat sink of the system can be either the ambient or ice. This second option ensures a constant low-pressure for the process that is favorable to turbomachines. A mixture of salt and water can be used to adjust the heat sink temperature between 0°C and -21.2°C (corresponding to the eutectic point with 23.3% of NaCl in the mixture) [10].

Different working fluids can be considered for the thermodynamic cycles. Desrues [13] presented a TEES process based on Argon in forward and backward closed Brayton cycles. Henchoz [13] analyzed the combination of solar thermal energy with TEES based on Ammonia cycles. Kim [14] reviewed current TEES systems and showed that using transcritical CO<sub>2</sub> cycles instead of Argon Brayton cycles leads to a higher roundtrip efficiency even if the required temperature difference between the heat storages is much smaller. He also proposed an isothermal energy storage system based on transcritical CO<sub>2</sub> cycles and liquid piston compressors/expanders.

Carbon dioxide is a natural refrigerant with many advantages. It is a low-cost fluid that is non-toxic, non-flammable, chemically stable, and readily available. In addition, the high fluid density of supercritical CO<sub>2</sub> leads to very compact systems. Many studies have been published to evaluate the potential of supercritical CO<sub>2</sub> as working fluid in power cycles and heat pumps [15-16]. Cayer carried out an analysis [17] and optimization [18] of transcritical CO<sub>2</sub> cycle with a low-temperature heat source. More recently, the use of CO<sub>2</sub> for multi-megawatt power cycles has reached a commercial step with the American company Echogen [19].

The purpose of this article is to introduce a new type of electro-thermal energy storage process for large scale electric applications, based on transcritical CO<sub>2</sub> cycles and ground heat storage. The association of such cycles and ground storage constitutes the originality of the project. The conceptual design of such TEES system is addressed here only from a thermodynamic point of view and economic analysis are left for future works.

## PROBLEM DEFINITION

The investigated electro-thermal energy storage system is a massive storage concept that includes:

i- a hot reservoir made of a set of ground heat exchangers in a low diffusivity rock;

ii- a cold reservoir using either ice ( $T_{\text{cold}} \leq 0^\circ\text{C}$ ) or a phase-change material ( $T_{\text{cold}} > 0^\circ\text{C}$ );

iii- two thermodynamic cycles as a charging process and a discharging process both using carbon dioxide as a working fluid

The basic overviews of these two processes are given respectively by Fig. 1 and Fig. 2. All the components of each process are considered as open systems in steady state. The system parameters including the component efficiencies are reported in Table 1. The thermodynamic model is implemented in the Engineering Equation Solver (EES) software [20].

During the off-hours, the charging process consists of a transcritical heat pump cycle characterized by 6 main steps: the working fluid leaves the cold reservoir heat exchanger as a saturated vapour at  $T_1 = T_{\text{cold}} - \Delta T_{\text{min}}$  and is internally superheated (1 → 2) through a regenerator, before being adiabatically compressed (2 → 3) with a mechanical compressor with isentropic efficiency  $\eta_{\text{s,c}}$ . At the compressor outlet, the fluid at  $T_3 = (T_{\text{hot}})_{\text{max}} + \Delta T_{\text{min}}$  and supercritical high pressure  $P_3 = \text{HP}$  is first cooled through the hot reservoir exchangers (3 → 4) releasing heat to the ground, then subcooled through the regenerator (4 → 5) releasing heat to the first flow. The fluid at a liquid state passes into an expansion valve (5 → 6) to reach the subcritical low pressure and is finally evaporated through the cold reservoir exchanger (6 → 1).

A detailed model has been developed and is extensively described in a previous paper [21].

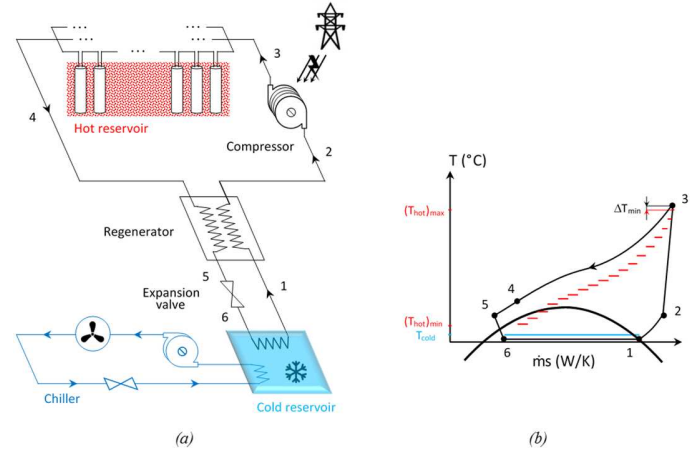

**Figure 1** Charging process: a) process layout, b) (T, ṁs) diagram.

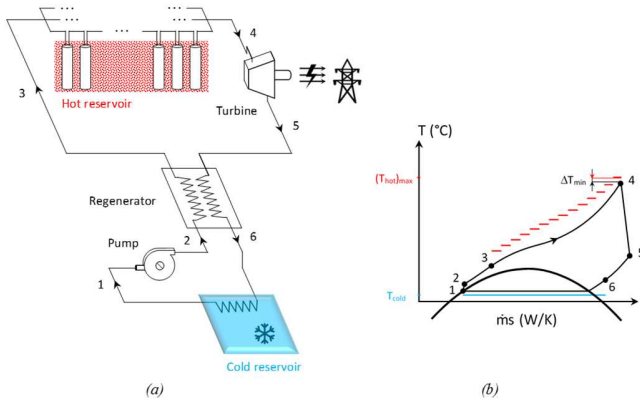

**Figure 2** Discharging process: a) process layout, b) (T, ṁs) diagram.

The energy balance of the charging cycle is [21]:

$$\dot{W}_c + \dot{Q}_{hot} + \dot{Q}_{cold} = 0 \quad (1)$$

During the peak-hours, the discharging process consists of a transcritical Rankine cycle characterized by 6 main steps: the working fluid leaves the cold reservoir heat exchanger as a saturated liquid at  $T_1' = T_{cold} + \Delta T_{min}$  and is adiabatically compressed ( $1 \rightarrow 2$ ) in a feed pump with isentropic efficiency  $\eta_{s,p}$ . At the outlet of the pump, the fluid at a supercritical high pressure  $P_2'$  is first preheated through the regenerator ( $2 \rightarrow 3$ ), then heated further through the hot reservoir exchanger ( $3 \rightarrow 4$ ) destocking heat from the ground. At the entrance of the turbine, the fluid at a defined temperature  $T_4' = (T_{hot})_{max} - \Delta T_{min}$  is adiabatically expanded ( $4 \rightarrow 5$ ) to the subcritical low pressure delivering a mechanical work with isentropic efficiency  $\eta_{s,t}$ . Finally, the fluid is cooled in the regenerator ( $5 \rightarrow 6$ ) before being condensed through the cold reservoir exchanger ( $6 \rightarrow 1$ ).

The energy balance of the discharging cycle is [21]:

$$\dot{W}_p' + \dot{Q}_{hot}' + \dot{W}_t' + \dot{Q}_{cold}' = 0 \quad (2)$$

By specifying the net power output of the discharging cycle  $\dot{W}_{el}' = \eta_g \dot{W}_t'$  and by assuming similar charging and discharging times,  $\dot{Q}_{hot}' \cong -\dot{Q}_{hot}$ . This gives the mass flow rates  $\dot{m}$  and  $\dot{m}'$  and then the net power input of the charging cycle  $\dot{W}_{el} = \dot{W}_c / \eta_m$ .

Furthermore, by adding equ. 1 and 2 and since  $\dot{Q}_{hot}' = -\dot{Q}_{hot}$ :

$$\dot{W}_c + \dot{Q}_{cold} + \dot{W}_p' + \dot{W}_t' + \dot{Q}_{cold}' = 0 \quad (3)$$

Equation 3 shows that there is an asymmetry between the two processes that can be expressed as an additional need of cooling:

$$\delta \dot{Q}_{cold} = \dot{Q}_{cold} + \dot{Q}_{cold}' = -(\dot{W}_c + \dot{W}_p' + \dot{W}_t') < 0 \quad (4)$$

This additional need of cooling can be provided by an auxiliary CO<sub>2</sub> chiller that processes independently and simultaneously with the charging cycle (Fig. 1a). The electrical consumption of the chiller  $\dot{W}_{el}''(W)$  as expressed by equation 5 is calculated using a simple-stage chiller model with condensing temperature at 20°C.

$$\dot{W}_{el}'' = \frac{-\delta \dot{Q}_{cold}}{COP} \quad (5)$$

On the other hand, the low diffusivity of the ground ensures the heterogeneity of the temperature therein (Figs. 1b and 2b), which seems to be favorable to maintain the cycles uniform at their nominal conditions over a long period of time. Assuming similar charging and discharging times, the overall efficiency of the whole system can be defined as:

$$\eta_{sys} = \frac{\dot{W}_{el}'}{\dot{W}_{el}' + \dot{W}_{el}''} \quad (6)$$

It is worth noting that the system performance as expressed above also relies on the stabilization of the ground temperature at the start of each process i.e.  $T_{hot} = (T_{hot})_{min}$  at the start of the charging process and  $T_{hot} = (T_{hot})_{max}$  at the start of the discharging process. This implies the achievement of a certain control during the shutdown sequence of each process in order to set and stabilize the ground temperature at the convenient value for the start of each following process.

Thereby, this steady-state analysis could be useful as a first approach for the assessment of the system performance especially at nominal conditions. This could be sufficient as comparative tool for the selection of the system design (non-regenerative, regenerative, single-stage, multi-stage) before coupling dynamically the charging and discharging processes to the ground properties.

Table 1. System constant settings

Charging cycle	
Compressor isentropic efficiency $\eta_{s,c}$	0,85
Motor efficiency $\eta_m$	0,98
$(T_4)_{min}$	30°C
Regenerator pinch	5K
Discharging cycle	
Net power output $\dot{W}_{el}'$	1 – 10 MWeI
Pump isentropic efficiency $\eta_{s,p}$	0,80
Turbine isentropic efficiency $\eta_{s,t}$	0,90
Generator efficiency $\eta_g$	0,98
Regenerator pinch	5K

As a preliminary work, pressure losses in the thermodynamic cycles are neglected. Simulation of the ground heat storage system will enable to estimate the head losses in that component and adjust the cycle parameters (see section “Modelling of the Hot Storage Ground Heat Exchangers”).

**RESULTS: ARCHITECTURE DISCUSSION**

Based on the previous modelling, it is possible to carry out a parameter analysis of the system. Figure 3 shows the efficiency of the system with respect to the temperature of the heat storages and architecture. It is possible to reach roundtrip efficiencies up to more than 50% with high storage temperatures and  $\Delta T_{min}=1K$ , on condition that regenerator is used in heat-pump and ORC cycles. Detailed results can be found in [21]. In particular a very interesting configuration can be found in Figure 4. The value of  $\Delta T_{min}$  is discussed in another section of the paper (see section "Modeling of the Hot Storage Ground Heat Exchangers").

Figure 4, Figure 5 and Figure 6 show the interest of having an architecture with a two-stage turbine configuration of the ORC system. The parametric results allow the comparisons between non-regenerated and regenerated configurations. Up to 7% can be gained. Figure 6 shows the interest of having an architecture with a two-phase turbine configuration in the heat-pump system instead of the valve. A value of 75% of isentropic turbine efficiency has been chosen as an achievable goal. The parametric results allow the comparisons between non-regenerated and regenerated configurations. Up to 6% can be gained. Combination of two-stage turbine configuration of the ORC system and a two-phase turbine configuration in the heat-pump system with regeneration if each cycle is studied in Figure 7. A maximum value of 65% in efficiency could be gained with such a system.

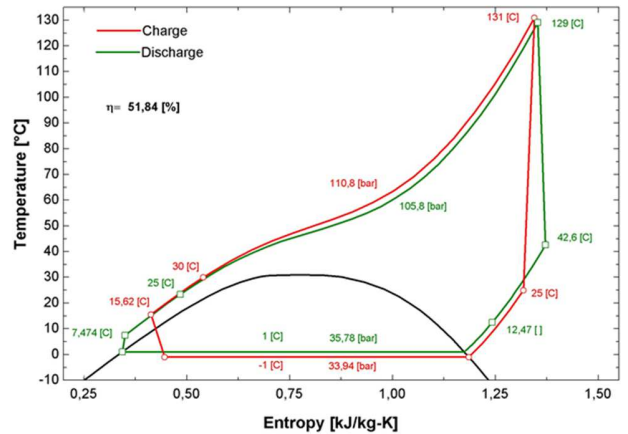

**Figure 4** T-S diagram for hot storage at 130°C and cold storage at 0°C ( $\Delta T_{min} = 1K$ ).

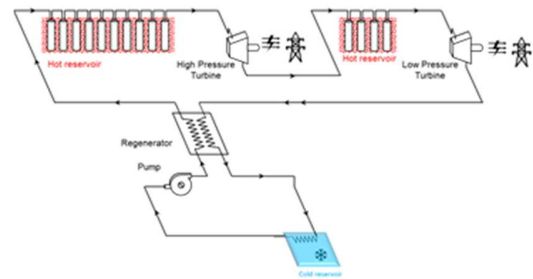

**Figure 5** Discharging process with a two-stage ORC turbine system: process layout

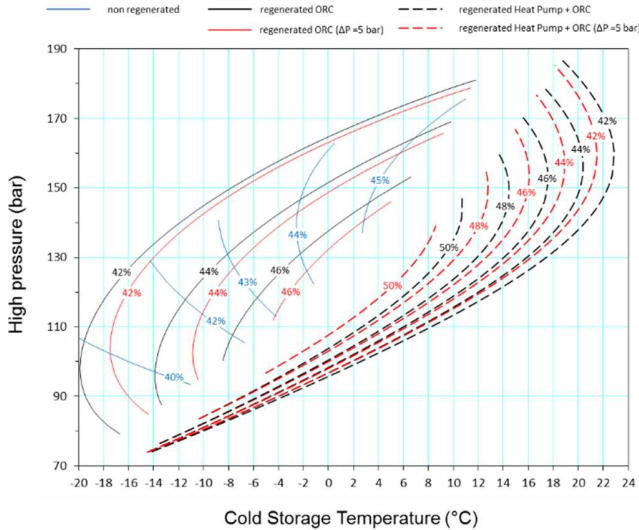

**Figure 3** Efficiency of the storage system with respect to the design storage temperature and pressure

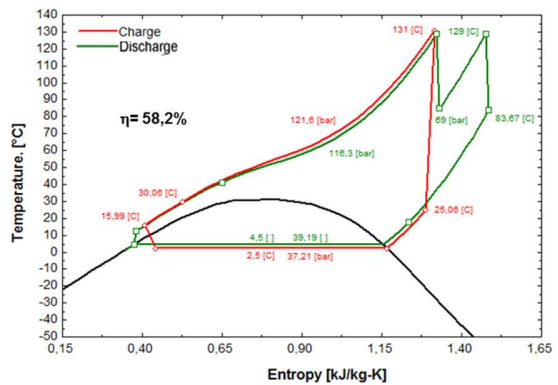

**Figure 6** Discharging process with a two-stage ORC turbine system: (T, s) diagram.

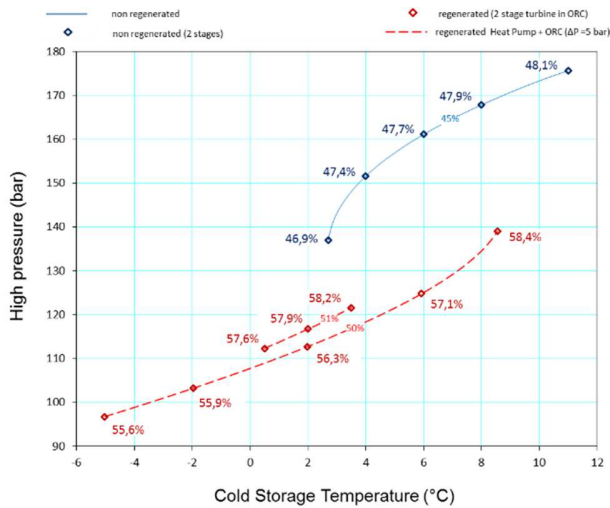

**Figure 7** Efficiency of the storage system with respect to the design storage temperature and pressure (two-stage turbine ORC system)

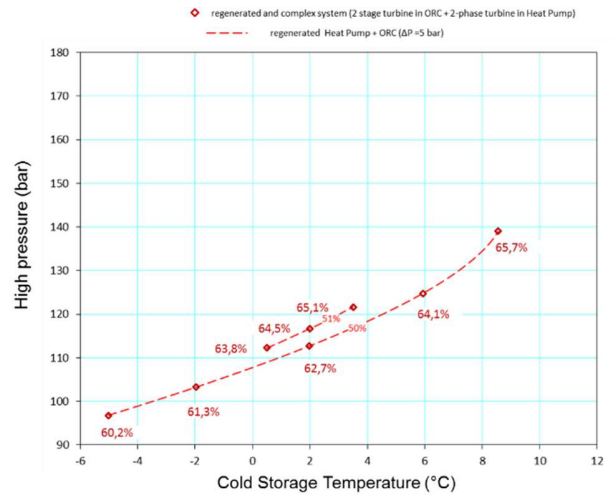

**Figure 9** Efficiency of the storage system with respect to the design storage temperature and pressure (two-stage turbine system and two-phase turbine system)

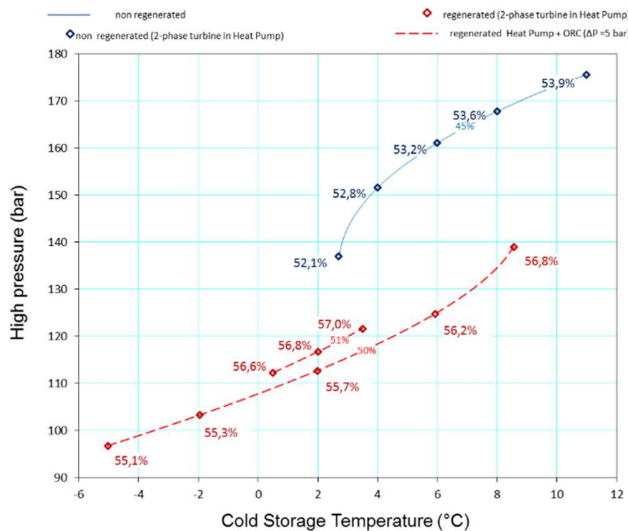

**Figure 8** Efficiency of the storage system with respect to the design storage temperature and pressure (two-phase turbine system)

## MODELING OF THE HOT STORAGE GROUND HEAT EXCHANGERS

The hot storage is made of vertical ground heat exchangers as shown in Figs. 1 and 2. All columns have the same geometry and are expected to be drilled in a serial-parallel arrangement.

It is worth noting that the quasi-limit case ( $\Delta T_{\min} = 1\text{K}$ ), analyzed in the previous section, could be constrained on one hand by the exchange area and then the number of drillings and columns to implement and on the other hand by the pressure drop that it generates. Thus, it is particularly important to consider these constraints in the thermodynamic study of the system, which would need to process to a preliminary design of the hot reservoir heat exchanger according to the “pinch setting”  $\Delta T_{\min}$ .

In this regard, the one-dimensional modeling is a simple and fast tool requiring low computing resources. This makes easy the coupling of the hot reservoir heat exchanger model to the thermodynamic model of the storage system. While it provides limited accuracy, the one-dimensional model of the heat exchanger could be useful to determine the suitable pinch setting and particularly helpful to indicate how optimizing the geometric configuration of the unitary column. The heat exchanger design would be conveniently refined thereafter by using advanced tools such as the CFD simulation.

### Model description

Fig. 8 gives the conceptual arrangement of the 1D discretization applied to a series of ground heat exchanger. The fluid at supercritical pressure is injected at the bottom of each column through a central tube and then flows up to an annular exit, transferring heat to the surrounding rock. As a preliminary simple modeling, we assume that there is no variation of wall temperature with depth in each of the ground heat exchangers. The central injection tube and the annular exit are assumed to be adiabatic as they will be coated with a thin insulation. The column characteristics are reported elsewhere [21].

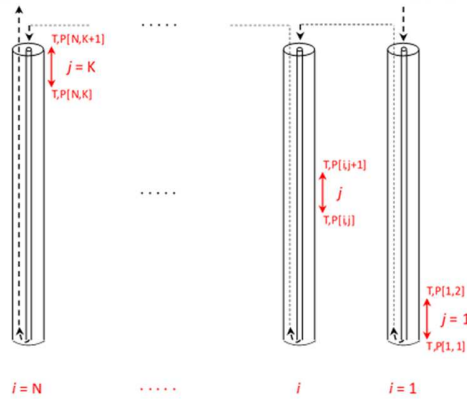

**Figure 10** 1D discretization of the ground heat exchanger network

The preliminary design of the heat exchanger is performed through EES on the basis of the nominal conditions of the discharging process. This preliminary design could also be valid for the charging process when adapting the initial ground temperature  $(T_{hot})_{min}$  (Fig.1b).

For a given  $\Delta T_{min}$ , the boundary conditions of the hot reservoir heat exchanger correspond to:  $\{T[1,1] = T_3', T[N,K+1] = T_4', T_{hot}[N] = (T_{hot})_{max}, T_{hot}[1] \geq (T_3' + \Delta T_{min})\}$ . For a given power output, the overall mass flow rate  $\dot{m}'$  (kg/s) and then the overall heat flux  $\dot{Q}_{hot}' = -\dot{Q}_{hot}$  (W) are distributed according to the number of series:

$$\dot{Q}_{hot}' = \dot{Q}_{series}' \times \frac{Nb_{columns}}{N}, \quad \dot{m}' = \dot{m}_{series}' \times \frac{Nb_{columns}}{N} \quad (7)$$

On the other hand, the heat flux transferred through one series

$$\text{verify the discretization concept: } \dot{Q}_{series}' = \sum_{i=1}^N \sum_{j=1}^K \dot{Q}[i,j] \quad (8)$$

$$\text{Where } \dot{Q}[i,j] = \frac{A}{K} U[i,j] \text{LMTD}[i,j] \quad (9)$$

$$= \dot{m}_{series}' (h[i,j+1] - h[i,j])$$

For each elementary segment, the log mean temperature difference is given by:

$$\text{LMTD}[i,j] = \frac{\Delta T[i,j] - \Delta T[i,j+1]}{\ln\left(\frac{\Delta T[i,j]}{\Delta T[i,j+1]}\right)} \quad (10)$$

$$\text{with } \Delta T[i,j] = T[i,j] - T_{hot}[i] \quad (11)$$

The model includes the calculation of both the regular pressure losses occurred within the central nozzle and the annular and the singular pressure losses due to the elbows, the sudden narrowing at the top of the column and the sudden enlargement at the bottom of the column:

$$\begin{cases} P[i+1,1] = P[i,K+1] - (P_{nozzle}[i+1] + \sum \Delta P_{sing}[i+1]) \\ P[i,j+1] = P[i,j] - \Delta P_{annular}[i,j] \end{cases} \quad (12)$$

By assuming a column wall temperature equal to the surrounding rock temperature ( $T_w[i,j] = T_{hot}[i]$ ), the elementary heat transfer coefficients  $U[i,j]$  are computed using the local Nusselt number correlation recommended by Jackson [22] for forced convection along a vertical turbulent flow of supercritical  $\text{CO}_2$ .

#### Discussion: $\Delta T_{min}$ impact

Coupling the thermodynamic model described in section 2 and hot storage heat exchanger model described in subsection 4.1 gives the results illustrated in Figs. 9a and 9b, with reference to a hot storage temperature of  $130^\circ\text{C}$  and 1 MW of discharging net power output. The cold storage temperature  $T_{cold}$  and the operating pressures are chosen to maximize the overall efficiency of the system. The figures show that the number of columns, the overall pressure drop ( $P_3' - P_4'$ ) and the system efficiency  $\eta_{sys}$  are all sensitive to the pinch setting ( $\Delta T_{min}$ ). By analyzing the (2 series / MWe) case, a  $\Delta T_{min}$  value between 5 and 8 K could be a good compromise between these three variants. Nevertheless, the overall pressure drop remains significant and contributes to the degradation of the system efficiency. On the other hand, the addition of series of columns to (4 series / MWe) allows to further reduce the pressure drop and then to increase the system efficiency. However, it is obvious that this is at the expense of the number of drilling and columns. Here, the choice should be challenged by an economic criterion that typically depends on the targeted power output. Furthermore, the review and the optimization of the geometric configuration of the unitary column might also be decisive.

By considering the hot reservoir heat exchanger constraints, the basic system would finally lead to moderate efficiencies at nominal conditions (around 45% for  $\Delta T_{min}=5\text{K}$ ). Therefore, it could be interesting to investigate others system designs such as a multi-stage discharging process, as exposed before.

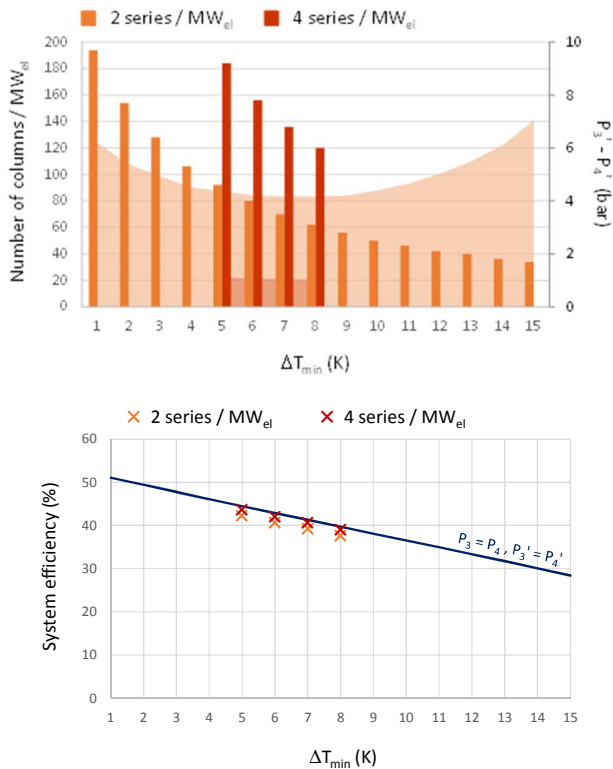

**Figure 11**  $\Delta T_{\min}$  impact on: a) the number of columns and the pressure drop, b) the system efficiency.

## CONCLUSION

The aim of this work is to assess the performance of a massive electricity storage involving CO<sub>2</sub> transcritical cycles and using the ground as a heat reservoir. The parametric study of the charging and discharging processes has shown roundtrip efficiencies up to more than 50% given by high storage temperatures and  $\Delta T_{\min} = 1$  K with a regenerative systems and 65% with more complex expansion processes.

In parallel, a one-dimensional model of the multicolumn heat exchanger was performed and coupled to the thermodynamic model of the whole system. This coupling has indicated that the number of columns, the overall pressure drop and the system efficiency are all sensitive to the pinch setting ( $\Delta T_{\min}$ ). The results have also shown that a  $\Delta T_{\min}$  value between 5 and 8 K could be a good compromise between these three variants. In this regard, the basic system would finally lead to moderate efficiencies at nominal conditions (around 45% for  $\Delta T_{\min} = 5$  K). Further work through the SELECO2 project will include turbomachinery and heat storage designs in order to have a more detailed overview of the system and of the dependency between the charging and the discharging processes which can represent large off-design conditions. Furthermore transient simulations of the complete charging/discharging cycle will be performed and confirm (or not) the efficiency value and the general interest of the device.

## ACKNOWLEDGEMENT

The authors acknowledge the support of the French Agence Nationale de la Recherche (ANR), under grant ANR-13-SEED-0004 (project SELECO2).

## REFERENCES

- [1] ENEA Consulting, Le Stockage d'Énergie. 2012.
- [2] Fujihara T, Imano H, Oshima K. Development of Pump Turbine for Seawater Pumped-Storage Power plant. Hitachi Review 1998 ; 47 (5): 199-202.
- [3] Crotagino F, Mohmeyer K-U, and Scharf R. Huntorf CAES: More than 20 Years of Successful Operation. Proc of SMRI Spring Meeting, Orlando, Florida, USA, 15-18 April 2001.
- [4] PowerSouth Energy Cooperative, CAES McIntosh Alabama.
- [5] Chris Bullough, Christoph Gatzen, Christoph Jakiel, Martin Koller, Andreas Nowi, Stefan Zunft, Advanced adiabatic compressed air energy storage for the integration of wind energy, in: Proceedings of the European Wind Energy Conference, London UK, 2004.
- [6] Grazzini G, Milazzo A. Thermodynamic analysis of CAES/TES systems for renewable energy plants. Renewable Energy 2008;32:1998-2006.
- [7] Mercangöz M, Hemrle J, Kaufmann L, Z'Graggen A, Ohler C. Electrothermal energy storage with transcritical CO<sub>2</sub> cycles. Energy 2012; 45: 407–415.
- [8] Desrues T, Ruer J, Marty P, Fourmigué JF. A thermal energy storage process for large scale electric applications. Applied Thermal Engineering 2010;30(5):425-32
- [9] Mercangöz M, Hemrle J, Kaufmann L. Thermoelectric energy storage system having two thermal baths and method for storing thermoelectric energy. Patent EP2241737
- [10] Ohler C, Mercangöz M. Thermoelectric energy storage system and method for storing thermoelectric energy. Patent EP2182179.
- [11] Henchoz S, Buchter F, Favrat D, Morandin M, Mercangöz M. Thermoeconomic analysis of a solar enhanced energy storage concept based on thermodynamic cycles. Energy 2012;45(1):358e65.
- [12] Kim YM, Shin DG, Lee SY, Favrat D. Isothermal transcritical CO<sub>2</sub> cycles with TES (thermal energy storage) for electricity storage. Energy 2013; 49: 484–501.
- [13] Morandin M, Maréchal F, Mercangöz M, Buchter F. Conceptual design of a thermo-electrical energy storage system based on heat integration of thermodynamic cycles. Energy 2012;45:375-396.
- [14] Morandin M, Mercangöz M, Hemrle J, Maréchal F, Favrat D. Thermoeconomic design optimization of a thermo-electric energy storage system based on transcritical CO<sub>2</sub> cycles. Energy 2013; 58: 571–587.
- [15] Kim YM, Kim CG, Favrat D. Transcritical or supercritical CO<sub>2</sub> cycles using both low- and high-temperature heat sources. Energy 2012; 43: 402–415.
- [16] Li M, Wang J, Li S, Xurong Wang, He W, Dai Y. Thermo-economic analysis and comparison of a CO<sub>2</sub>

- transcritical power cycle and an organic Rankine cycle. *Geothermics* 2014; 50: 101–111.
- [17] Cayer E, Galanis N, Désilets M, Nesreddine H, Roy P. Analysis of a carbon dioxide transcritical power cycle using a low temperature source. *Applied Energy* 2009;86:1055–63.
- [18] Cayer E, Galanis N, Nesreddine H. Parametric study and optimization of a transcritical power cycle using a low temperature source. *Applied Energy* 2010;87:1349-1357
- [19] Held T., Initial Test Results of a Megawatt-class Supercritical CO<sub>2</sub> heat engine. The 4th International Symposium – Supercritical CO<sub>2</sub> Power Cycles; 2014 Sept 9-10; Pittsburgh, USA.
- [20] S.A. Klein, Engineering Equation Solver. F-Chart Software, Middleton, WI, 2010.
- [21] Ayachi F., Tartièrè T., Tauveron N., Colasson S., Nguyen D., Investigation of a massive electricity storage system by means of a geothermal heat transfer process involving CO<sub>2</sub> transcritical cycles, ASME-ORC Conference, 2015.
- [22] Jackson, J. D., Hall, W. B., Fewster, J., Watson, A., Watts, M. J., 1975, Heat transfer to supercritical fluids, U.K.A.E.A. A.E.R.E.-R. 8158, Design Report 34.