

ANALYSIS AND OPTIMIZATION OF A VERTICAL AXIS WIND TURBINE SAVONIUS-TYPE PANEL USING CFD TECHNIQUES

J. Vilarroig, S. Chiva*, R. Martínez and J. Segarra**

*Author for correspondence

** Heliotec.SL

Department of Mechanical and Construction Engineering

Universitat Jaume I,

Castellón de la Plana, Av. de Vicent sos Baynat s/n 12071,

Spain,

E-mail: schiva@uji.es

ABSTRACT

The aim of this study is to analyze and optimize a vertical axis Savonius-type wind turbine using Computational Fluid Dynamics (CFD). The study is developed in two parts. In the first part of the study, an analysis of the main design parameters is made using semi-empirical models. The second part of the study is focused on the CFD simulations using Ansys CFX. First of all, steady state simulations have been made in order to ensure a reliable model to predict the Savonius behavior. After steady state, transient state simulations have been calculated to obtain not only the Coefficient of Power (C_p) curves but also the setting time at different wind speeds and using different materials. The transient state simulations have been implemented using a subroutine that calculates the torque produced by the turbine in each time step. Finally, Using the steady state simulations it has been possible to study the interaction of 4 Savonius situated in a row for different angular positions of each turbine.

INTRODUCTION

The Savonius wind turbine is a vertical axis turbine developed in the sixties. Its popularity has been increasing since the last decade due to its simple construction with low cost, it operates at low angular velocities which reduces the noise and the variety of rotor configurations that it can present. The Savonius wind turbine can be considered both as a drag-driven and lift-driven wind turbine. Since the drag effect is stronger than the lift, these turbines present higher efficiency than turbines that are only drag-driven and (which usually present efficiency values of 18-20%) This means that if an optimal configuration is selected, the efficiency can reach values of 28-30% [1].

One of their main weaknesses is its low power generation. since these turbines are usually compact the energy delivered is generally below 1 kW. That is why sometimes more than one Savonius is required to reach de desirable power. Although the energy obtained cannot be compared with the turbines currently used in wind farms (three-bladed airscrew) it is suitable for certain applications in which low energy at low cost is required i.e. isolated places where energy for electric valves or small engines is required.

This particular study was based on a prototype that can be seen in Figure 1. It was necessary to determine if the geometry was close enough to the optimal or if it was necessary to do some changes in order to obtain a target power of 100W per Savonius (that is 400W from the panel). The panel was formed by 4 double staged Savonius with 2 semicircular buckets in each turbine. The values of the different geometrical parameters of the Savonius turbine can be observed in Figure 2.

NOMENCLATURE

A	[m ²]	Swept area of the rotor
C_p	[-]	Power coefficient
C_q	[-]	Torque coefficient
D	[m]	Rotor diameter
d	[m]	Bucket diameter
e	[m]	Gap width
a	[m]	Shaft diameter
H	[m]	Bucket high
U	[m/s]	Wind speed
M	[N·m]	Mechanical axial torque
P	[W]	Power delivered by the rotor
N	[rpm]	Rotational speed
I	[kg·m ²]	Inertia

Special characters

α	[-]	Aspect Ratio
β	[-]	Overlap
λ	[-]	Tip Speed Ratio
ω	[rad/s]	Angular Velocity

STUDY OF MAIN DESIGN PARAMETERS

Since the Savonius wind turbine has become very popular in the last decades, all the possible design parameters have been largely studied. Due to the disparity of these studies, it is difficult to make comparisons of the obtained results. That is why many of these optimal parameters and ratios for the geometry have been reviewed in some studies [2,3]. These studies emphasize the importance of certain parameters and ratios which are: aspect ratio, overlap, number of buckets, rotor stages and influence of some elements like end plates or shaft. The values considered as optimum, were compared with those provided by the prototype in order to ensure that the geometry design will provide the maximum efficiency.



Figure 1 Prototype used for the study

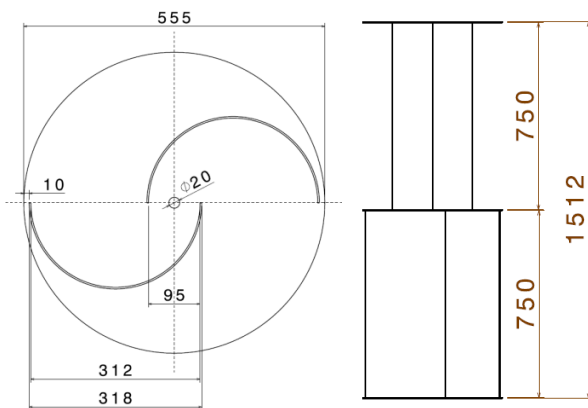

Figure 2 Geometrical parameters of one single Savonius turbine

Aspect ratio

The aspect ratio is the adimensional parameter that relates the turbine height H with its diameter, D as follows:

$$\alpha = \frac{H}{D} \quad (1)$$

As proposed by [2], high aspect ratio values have low losses and thus, provide higher power coefficients. It also mention that values about 2.0 usually present good results. On the other hand, studies made by [4] suggest that in order to improve the efficiency this value should be round 4.0. Since the prototype gives a aspect ratio value of 2.81 was considered acceptable.

Overlap

The overlap ratio is the relation between the gap width, e , and the bucket diameter, d . It is represented as:

$$\beta = \frac{e}{d} \quad (2)$$

This is probably the most studied and most controversial parameter. The studies made by [1] suggest that the best overlap values are round 0.1 while studies from [5] conclude that this values should be between 0.2 and 0.3. For the present study, the values from [3] (overlap between 0.22 and 0.3) have

been considered to be the most adequate. Since the prototype presented an overlap value of 0.29, it was concluded that the distance between the buckets was also adequate.

Number of buckets

According to [1], the addition of blades helps the rotor to reduce the oscillations of the dynamic and the static moment. When the number of blades in the rotor increases, the range of values where the rotor moment is low decreases. However, the best power coefficient is reached with two buckets because of the "cascade effect" produced when the air deflected by one bucket increases the performance of the following bucket as explained in [1,6]

Number of stages

The addition of stages is made to reduce the rotor's vibrations that decrease the rotor's durability. Moreover, the addition of stages increases the moment in some angular positions where the static torque is negative or very small. When adding stages the probability of some stage to be in a favorable position to the extraction of momentum from air flow increases and this stage helps the others in a worse position. Therefore there is a reduction on the moment fluctuations, although the maximum torque given is lower than the maximum given by a single rotor as was concluded by [1,4]

End Plates and Shaft

The plates situated at top and bottom of the turbine, prevent the escape of the air from the concave side of the blades. This has a positive effect on the C_p obtained. However, very high diameters or large thickness could increase the rotor inertia and decrease the efficiency of the Savonius. That is why a negligible thickness compared with the Savonius height and a diameter equivalent to 1.1 times the rotor diameter is recommended. [2,6,7].

In the study made by [3] using dynamic calculation, is it demonstrated that the effect of the shaft is negligible and does not affect the C_p either positively or negatively.

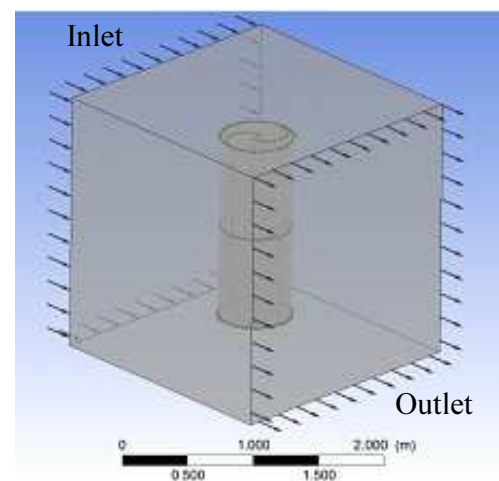

Figure 3 3D model and boundary conditions used for the steady state simulations

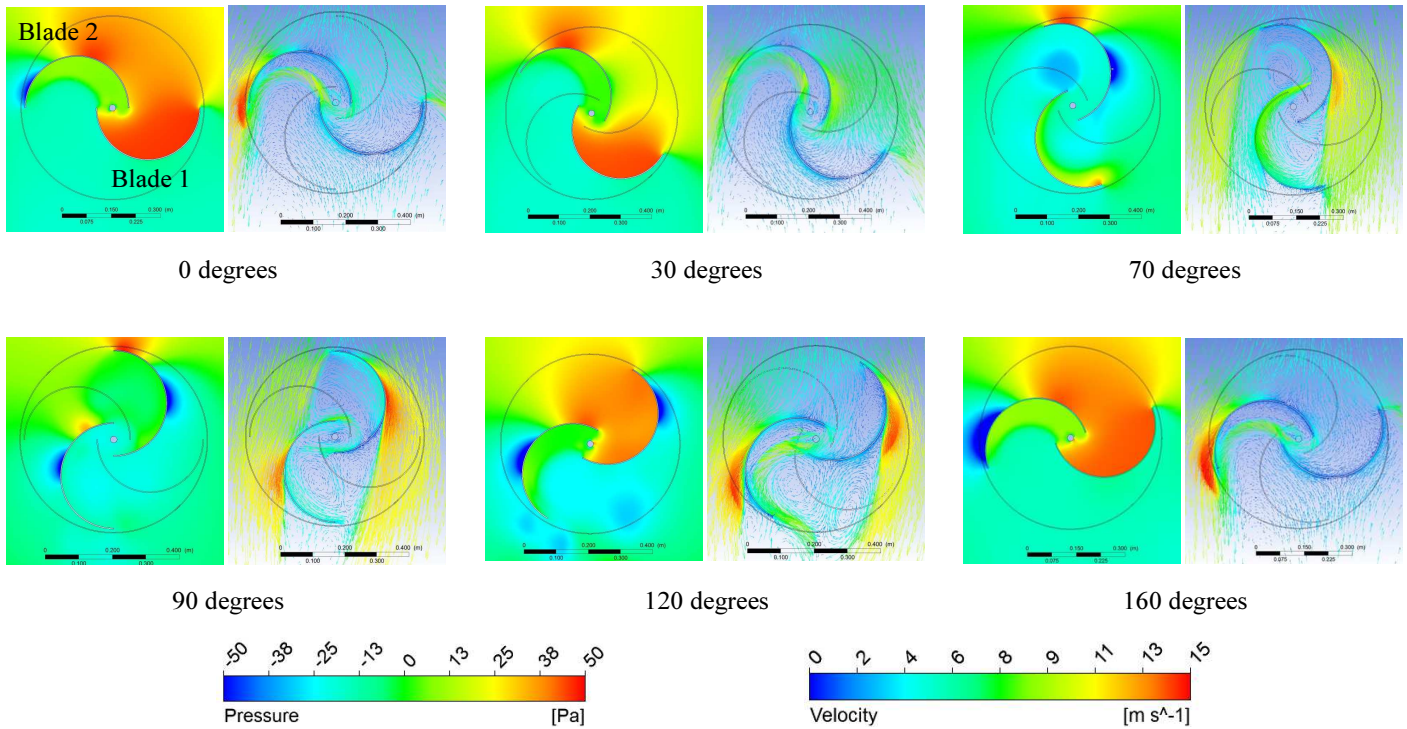

Figure 4 Pressure (left) and Velocity (right) distributions in a 180° turn of a single stage Savonius. Steady state simulations.

STEADY STATE SIMULATIONS

The steady state simulations were calculated using a 3D model situated inside the volume that can be seen in Figure 3. This volume was 2100 mm high, 2000 mm long and 2000 mm wide to minimize on the effects of the fluid domain walls on the flow around the set up. The model was meshed using an inflation layer round the blades (first layer thickness of 0.05mm), and a 3-10 mm sizing inside the rotor domain; the static domain had a maximum sizing of 100mm. The global number of nodes was 2900000. An $y^+ < 2$ was obtained over the blades surfaces.

This meshing model was validated using the experimental wind tunnel data from "Run 35" of Blackwell [1] which studied the same Savonius in steady state (with no rotation) at different rotor positions and with 7 m/s airflow. The results obtained with CFD showed a good agreement (the simulation slightly overestimates) with the experimental data (see Figure 5), so the meshing model was considered acceptable for the study.

The boundary conditions used were simple and are shown in Figure 3. The inlet condition was a 7 m/s airflow while the condition at the outlet was set as atmospheric pressure (0 Pa). All the other boundaries were considered as walls. The simulation was calculated using the Shear Stress Transport turbulence model (SST) in order to consider small eddies and boundary layer separation. Three different simulations at 3 different positions were made. Since the model was double staged, while the upper Savonius had a position of 0, 30 and 70 degrees, the bottom Savonius presented positions of 90, 120 and 160 degrees respectively. This way, the torque for a

complete turn of a single stage Savonius could be obtained and the torque for the double staged can be calculated as a sum of the upper and bottom Savonius torques.

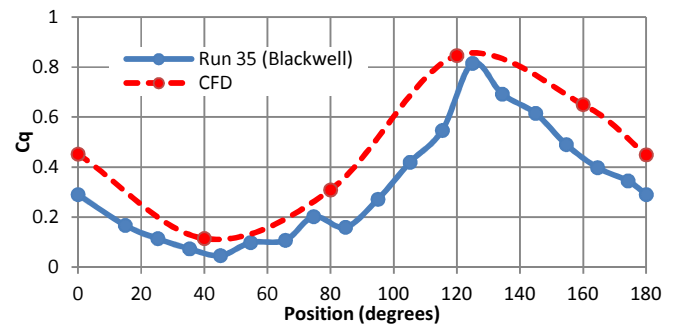

Figure 5 Comparison between experimental data (Run 35 Blackwell) and CFD simulations

The pressure and velocity distributions were calculated in each position Figure 4. This enabled the calculation of the torque produced not only by each blade (1 or 2) but also by each side of the blade, that is, the concave side and the convex side as is showed in Figure 6. In the distributions showed in Figure 4, two positions must be empathise: the 90 degrees position (minimum torque delivered) and the 120 degrees position (maximum torque delivered).

This is the position that gives the lowest torque. the two blades are completely aligned so the air could not hit any of the two concave sides, so no torque can be produced. However, in the two convex sides, separation of boundary layer can be appreciated. This generates a low pressure area and a force that

is perpendicular to the convex side of each blade. Although this is a small force, it is enough to generate a torque in the rotation direction and avoid the total torque to be in the opposite direction of the rotation direction.

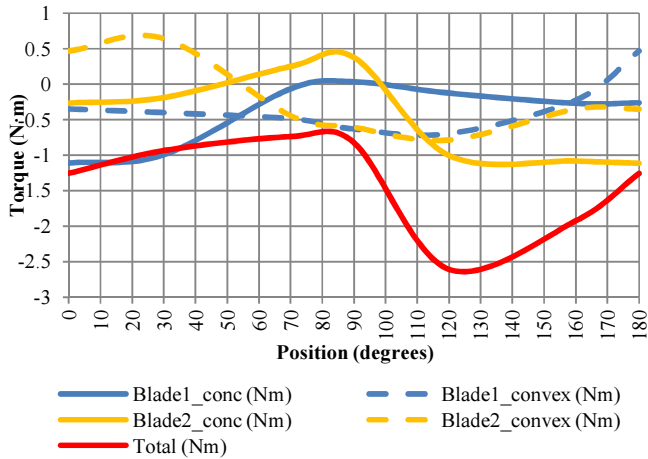

Figure 6 Torque obtained from the steady state simulations for each blade (1 and 2) and each part (convex and concave) for a single staged Savonius (750 mm high)

Contrary to what occurs at 90 degrees position, at 120 degrees the Savonius gave the maximum torque. This is due to the combination of the effects of both lifting and drag effect. The torque given by the concave side of the blade 2 is maximum because this side is faced to the wind so the air is accumulated in this side. The convex sides of blades 1 and 2 reach the maximum torque due to the boundary layer separation that produces a low pressure area and a force that generates a torque in the direction of rotation. Finally, the torque in the concave side of blade 1 increases due to the airflow that goes through the central gap. This airflow hits this side generating a torque in the direction of movement.

TRANSIENT STATE SIMULATIONS

Because of the excessive calculation needed on the transient state simulations when using the 3D model simulated in steady state, a new 2D model had to be created to accelerate the data collection and obtain a complete analysis of the Savonius from steady state to the final angular velocity setting. The 2D model was based on the 3D model, so the same geometry and meshing methodology was used (see Figure 7). In the boundary conditions it was necessary to introduce the condition of symmetry as done in other studies like [7] but the inlet and outlet condition as well as the interphase characteristics were maintained Figure 8.

In order to calculate the setting time and C_p , it was necessary to implement a subroutine to obtain the rotation of the Savonius by itself, just using the condition of the speed at the inlet and calculating the summation of the torques in each blade and in each time step following the equation:

$$I \cdot \dot{\omega} = \sum M \quad (3)$$

With an initial value of omega and the inertia value previously introduced in the boundary conditions the subroutine obtained the summation of the torques from Ansys results and calculated new value of omega. This value was given again to Ansys and it calculated the torque and the omega value in the next timestep. This way it was possible to obtain the variation of the torque and the angular velocity in each time step.

As occurred with the steady state simulations, the transient state simulations were just capable to predict the setting time and CP for a single stage Savonius but not for the double staged. However, the geometry of the turbine, the model that had to be used to calculate the simulations and the aerodynamic behaviour were clear and validated with steady state simulations. Since the purpose of transient simulations was to determine what material was the most appropriate to build the Savonius, the transient simulations were useful in order to make comparisons between the two different materials that wanted to be tested (aluminum and poliester reinforced with fiber glass). The only difference between the simulations using one material and the other was the inertia of the turbine. As the selection of the electrical engine was not the aim of the study, the resistant torque used in the simulations was only determined by the bearings friction. So the setting time curves represent the rotational speed of the rotor when there is not any alternator connected to the shaft.

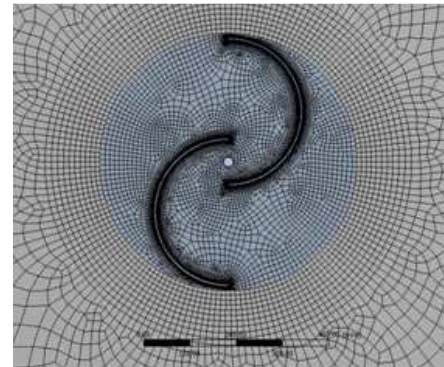

Figure 7 Meshing used for the 2D transient state simulations

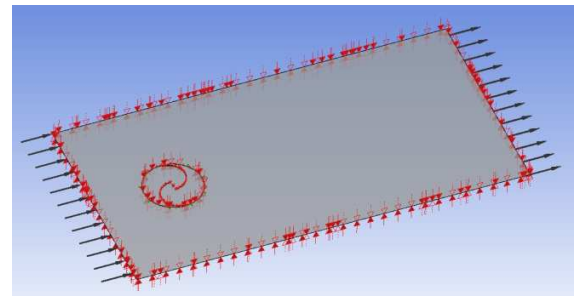

Figure 8 Entire model for the 2D transient state simulations

SIMULATIONS OF THE 4 SAVONIUS PANEL

Since the Savonius were not going to work as an isolated turbine but they were in a row configuration, it was necessary to determine whether some interaction (positive or negative) appeared when the wind flow passed through the Savonius turbines. Although this configuration was capable to produce more energy (400W instead of 100W) it has a great weakness; in order to obtain the maximum power, the panel must be oriented to the wind direction, so the Savonius losses its main advantage of not needing to be orientated to the airflow.

Moreover with this new configuration also new design parameters have to be studied i.e. how did the airflow direction affect to the turbines when it not be perfectly orientated with the panel, the distance between the turbines or the effect of the torque when the turbines were at specific angular positions. Since the analysis of 4 turbine CFD model in order to study their interaction required of great amount of computational resources, for this study only the last two parameters has been studied. Moreover, this study was made using transient state simulations and a 2D model similar to the model used for the transient state simulations.

To cover up as many possibilities as possible 9 different steady state simulations were made for 3 different Savonius separation (10, 100 and 300 mm) and for 3 different angular positions (0, 90 and 120 degrees). The separation was referred to the distances between each Savonius endplate. In the prototype design, this separation was 10 mm and was increased to 100 and 300 mm to study the effect on the Savonius torque. In the angular positions criteria, all the Savonius were in the same position. These 3 different positions were chosen because they represent the maximum torque position (120 degrees), the minimum torque position (90 degrees) and the maximum area exposed to the wind direction (0 degrees).

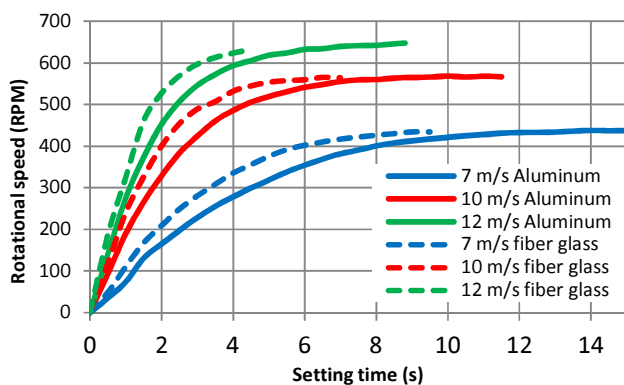

Figure 9 Setting time for aluminium (a) and fibber glass Savonius (b)

RESULTS

Transient state results

The first parameter that was analyzed in the transient state simulations was the setting time. As was expected, the results show that the setting time for low speed wind flow were faster

than those for higher speed wind flow and the rotational speed reached was also lower as can be seen in Figure 9,

Comparing the curves of the aluminum Savonius Figure 8a with the fiber glass curves Figure 8b it is observed that when using the fiber glass Savonius, the setting time is reduced and all the setting times in all cases (7, 10 and 12 m/s) were lower than the setting times for the aluminum Savonius.

This can be attributed to the different inertia values. As the inertia value is reduced, the turbine present quicker reaction to wind speed changes. Likewise, if the acceleration is higher, the rotor can reach the steady state rotation sooner and this way can take better profit from short gusts of air.

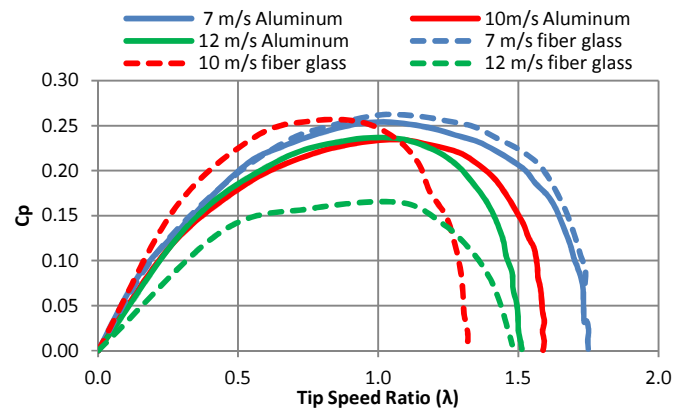

Figure 10 C_p Values for aluminium and fibber glass Savonius

However, as can be seen on Figure 10, the C_p values for the aluminum Savonius presented better values than those for the fiber glass. Since the improvement obtained with the C_p values for the aluminum Savonius were significant compared with its slower response due to the inertia, it was considered the aluminum Savonius as the most adequate material to build the 4 Savonius panel plant. Moreover, knowing the value of λ that maximizes the C_p , it is possible to obtain the angular velocity from eq. 3 for which the Savonius operates at its maximum efficiency.

$$\omega = \frac{\lambda \cdot U}{R} \quad (4)$$

The estimated angular velocities that maximized the C_p at 7, 10 and 12 m/s for the aluminum Savonius were 132, 189 and 227 RPM respectively. This was an important parameter in order to obtain an alternator and a reduction gear box that could provide these range of angular velocities.

Results of the 4 Savonius panel simulations

In the 0° position case, when the Savonius are close to each other accumulate all the coming air and that generates a huge low pressure area in the center of the four Savonius that decreases the torque delivered. When the Savonius are separated, there is less accumulation of coming air and the Savonius do not affect to each other (see Figure 11).

In the 90° position case, the air speed between the Savonius increases when the separation is small. This increases the effect of the boundary layer separation and the force due to this effect

(that benefits the Savonius rotation) increases. However when the Savonius are more separated, the forces due to the boundary layer separation effect decreases and the torque delivered is lower.

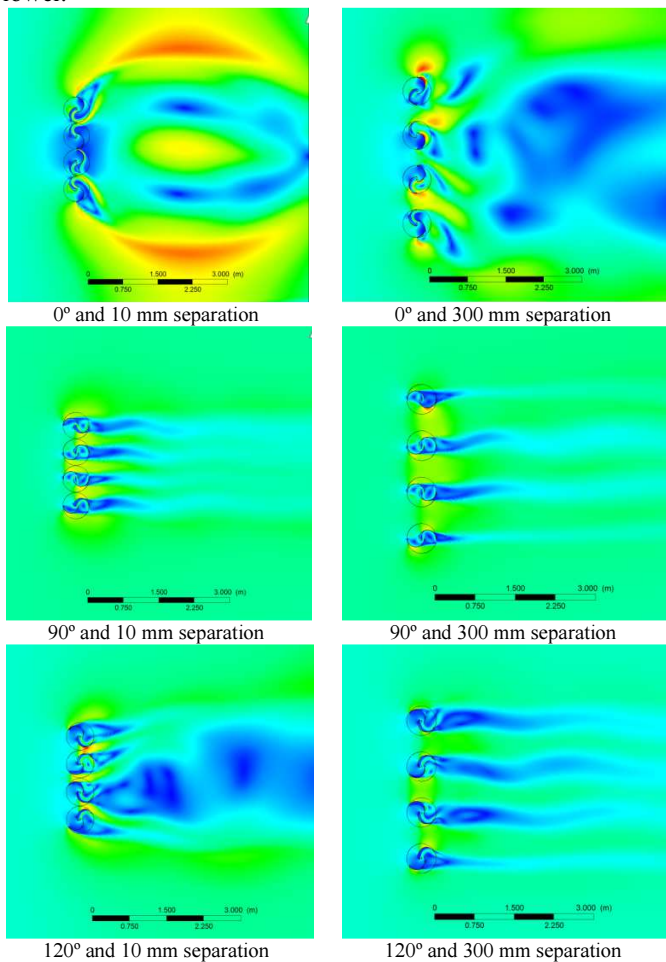

Figure 11 Results of the 4 Savonius panel simulations

In the 120° position case, the explanation is not as clear as in the other cases. At 120 degrees position the torque delivered by the rotor is originated by the boundary layer separation effect but also by the wind drag force over the blades, so in each separation 0, 100 and 300 mm, depending on the importance of each effect (drag force or boundary layer separation) the torque delivered will change. In general, a small separation between the Savonius increases the accumulation of air and the drag force. Moreover, as have been explained in the 90° position case, a small separation of the Savonius increases the boundary layer separation effect. So it seems that the closer the Savonius are the higher torque they deliver. However, when they are close to each other the pressure and speed distribution of one Savonius, can easily affect the next Savonius and in this case it is difficult to determinate what is going to happen.

CONCLUSIONS

In the present research, a complete study for the analysis and optimization of a Savonius wind turbine energy system has

been done. The main conclusions obtained, can be summarized as follows:

- A review of the main design parameters to design a Savonius wind turbine has been made. All these parameters have been compared with the prototype proposed and it has been checked that they are very close to the optimal.
- The 3D CFD model has been validated using experimental data from other studies that used wind tunnel and it has been possible to develop a 2D transient state model to analyse the setting time and the power coefficient. This model has predict that the best construction material for the Savonius is aluminium due to its better power coefficients.
- The interaction between the 4 Savonius in the row configuration has been studied. It has been very complex to find a trend for the power coefficient of the Savonius when varying its separation or its angular position. However, it has been observed that both angular position and separation between the Savonius, affect to the torque obtained and thus to the power coefficient.

As the computer resources were limited, it has been not possible to produce more refined models. In further studies a 3D models should be use to study the transient state simulations and obtain the complete torque curve and power coefficients for the two staged Savonius instead of an estimation from 2D models. This 3D model could also be used to analyse the 4 row Savonius configuration. The variation of the power coefficients as well as the aerodynamic behaviour for different wind orientations could be analysed using this model in future studies.

REFERENCES

- [1] Blackwell, Ben F., Sheldahl, Robert E. and Feltz, Louis V. 1977. Wind Tunnel Performance Data for Two- and Three-Bucket Savonius Rotors. *United States Energy Research and Development Administration*,. 1977.
- [2] Akwa, J.V., Vielmo H.A., Petry A.P., A review on the performance of Savonius wind turbines, *Renewable and Sustainable Energy Reviews* , Vol. 16, 2012, pp. 3054-3064
- [3] Menet J.L., Bourabaa N., Increase in the Savonius rotors efficiency via a parametric investigation, *European Wind Energy*.
- [4] Menet J.-L. A Double-Step Savonius Rotor for Local Production of Electricity: a Design Study. *Renewable Energy*, 2004, Vol. 29, pp. 1843-1862.
- [5] Alexander A.J. and Holowia B.P., 1978. Wind Tunnel Tests on a Savonius Rotor. *Journal of Industrial Aerodynamics*. 1978, Vol. 3, pp. 343-345.
- [6] Saha, UK., Thotla S, Maity D. Optimum design configuration of Savonius rotor through wind tunnel experiments. *J Wind Eng Ind Aerod*, Vol. 96, 2008, pp. 1359–75.
- [7] Kacprzak, K., Liskiewicz, G., & Sobczak, K., Numerical investigation of conventional and modified Savonius wind turbines. *Renewable energy*, 2013, Vol. 60, pp. 578-585.
- [8] Tartuferi, M., D'Alessandro, V., Montelpare, S., & Ricci, R., Enhancement of Savonius wind rotor aerodynamic performance: a computational study of new blade shapes and curtain systems. *Energy*, 2015, Vol.79, pp. 371-384.