

PRESSURE DROP IN THE TRANSITIONAL FLOW REGIME INSIDE SMOOTH TUBES WITH TWISTED TAPE INSERTS

Abolarin S.M. and Meyer J.P.*

*Author for correspondence

Department of Mechanical and Aeronautical Engineering,
University of Pretoria,
Pretoria, 0002,
South Africa,
E-mail: josua.meyer@up.ac.za

ABSTRACT

The reduction in energy consumption and improvement of productivity in industries, particularly in industrial heat exchangers, has become a concern worldwide. One of the readily available methods of achieving this is by operating heat exchangers in the transitional flow regime. This regime encourages the use of small pump size as compared to the turbulent flow regime; thus encouraging energy efficiency by the reduction of associated energy consumption. This paper presents the results of an empirical investigation of fully developed diabatic friction factors of flow in a smooth circular heat exchanger equipped with twisted tape insert with a twist ratio of 5. This experiment was conducted using water as the working fluid over a range of Reynolds numbers of 500 to 10 000 spanning the laminar, transitional and turbulent flow regimes and Prandtl numbers of 3.9 to 6.7 with a square-edge inlet. The results were also validated with correlations of previous studies on smooth tubes. The diabatic friction factor results with heat flux of 2 kW/m^2 are presented in this paper. The commencement of transition was observed at a Reynolds number of 2 700 and ended at a Reynolds number of 3 187 for the smooth tube. The transition range during the enhanced tube experimentation started at a Reynolds number of 750 and ended at 2 082. The commencement of transitional flow regime was earlier with twisted tape insert compared with ordinary smooth tube. The early transition of this enhanced tube indicates that heat exchangers can now be designed and operated at relatively low pressure thus encouraging energy management.

INTRODUCTION

Heat exchangers with improved performance and low energy consumption are now desired in this present age. These requirements are necessary as both the domestic and industrial sectors are now facing difficult energy challenges with respect to availability and access. One of the methods of achieving this improvement both in design and operations of heat exchangers is by operating these devices in the transitional flow regime.

Heat exchangers over the years are found in many engineering applications and research studies. Some of these include domestic services [1], process and chemical reactors [2], fossil fuel power plants and concentrated solar power plant station [3], food processing [4] to mention a few.

Enhancing the overall performance of these heat exchangers and operating them at relatively low cost is vital to achieving industrial goals where these devices have found greater application. One of the enhancement techniques is the insertion of twisted tapes into the heat exchangers, although this is accompanied with increased pressure drop [2]. However, operating in transition flow regime helps achieve better performance and reduced pressured drop as compared with turbulent flow regime. This reduced pressure drop translates to reduced energy consumption and related costs.

There are three flow regimes in fluid mechanics and heat transfer engineering. These are laminar, transitional and turbulent flow regimes. The transitional flow regime occurs in between laminar and turbulent flow regimes. Research investigation of this regime has been neglected because of reasons such as limited or incomplete understanding [5], unreliable prediction [6] and inherent uncertainty and instability [7].

However, in the past two decades, both computational and empirical investigations are now placing emphasis on research investigations in the transitional flow regime. This is because the pressure drop in this regime is lower than that of the turbulent flow regime. Of particular interest to this paper are the previous studies by Ghajar and his co-workers from Oklahoma State University [8-11] and the research work of Meyer and his students from the University of Pretoria [1, 12-14]. However, many of these studies are carried out using smooth tubes.

These researchers have identified various factors responsible for the commencement of transitional flow regime in smooth circular tubes. Some of these influencers include varying tube diameters [1] and three different inlet configurations [8, 10, 11, 15, 16]. These inlet sections are classified as re-entrant, square-edge and bellmouth. Each of these inlets influence the occurrence of the critical Reynolds numbers from laminar to turbulent.

The work of Meyer and Olivier [1] shows that transition started for the square-edge inlet at a Reynolds number of 2 600. However, the boundary condition considered in the study was constant wall temperature. The influence of tube diameters on the critical Reynolds number was published in the work of Olivier and Meyer [14], Meyer, et al. [17]. The study

considered two smooth circular tubes under constant wall temperature boundary condition with inner diameters of 15.88 mm and 19.02 mm. Transition was reported to have started at a Reynolds number of 7 000 and 12 000 for the 15.88 mm and 19.02 mm respectively.

On the use of twisted tape inserts as a passive enhancement technique in heat exchangers, some studies have been done including development of correlations in the laminar [18-21] and turbulent flow regimes [22]. The first authors to investigate thermohydraulic enhancement in laminar flow, Hong and Bergles [19] recommended tests in the transitional flow regime for the development of composite correlations for all the flow regimes. On the transitional flow regimes, previous studies have only stated arbitrary region of transition with the use of twisted tape inserts without specifics [23, 24]. However, to the best of the knowledge of the authors of this paper, no detailed research work has been carried out on the influence of inlet section on the transitional flow regime in heat exchangers with twisted tape inserts, hence the purpose of this study.

The focus of this paper is to present new results of the influence of square-edge inlet configuration on the occurrence of transition of adiabatic and diabatic friction factors in smooth tubes with water as working fluid in a horizontal smooth circular copper tube.

The criteria used in this paper for the identification of the critical Reynolds number in heat exchangers with twisted tape insert is similar to that of the smooth tube. The first criterion is the pressure drop fluctuations observed as compared with laminar and turbulent flow regime. These fluctuations were repeated in all the heat fluxes considered and even in adiabatic conditions with different tape geometries. The second criterion is curve fitting.

NOMENCLATURE

D	[mm]	Diameter of the test section
L	[m]	Length of the test section
\dot{m}	[kg/s]	Mass flow rate
p	[kPa]	Pressure drop
T	[°C]	Temperature
U	[m/s]	Velocity
x	[m]	Distance from tube inlet

Greek symbol		
ρ	[kg/m ³]	Density of the working fluid
μ	[kg/m.s]	Dynamic viscosity

Dimensionless variable

f	[-]	Friction factor
Re	[-]	Reynolds number

Special characters

Δ	[-]	Change
----------	-----	--------

Subscripts

b	Bulk
e	Exit
f	Fluid
h	Heating
i	Inlet
m	Mean or average

EXPERIMENTAL SETUP

The test section consisted of a single 5 m heat exchanger tube of copper material with an inner diameter of 19 mm and wall thickness of 1.5 mm. The twisted tape was manufactured from copper plate of 1 mm thick. The width and pitch of the twisted tape were 18 mm and 90 mm respectively. The heated length of the test section was considered for only fully developed region. This means that, the laminar and transition heated length was 2.45 m and for the turbulent was 4.8 m. The schematic diagram of the test loop is presented in Figure 1.

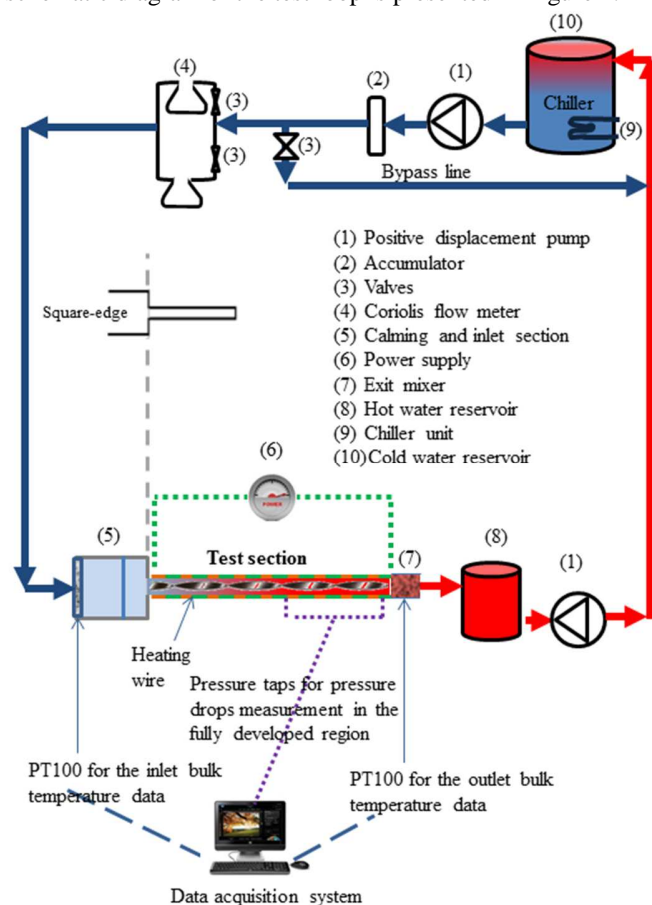

Figure 1 Schematic diagram of the friction factor experimental setup with twisted tape insert

Water was used as the working fluid, over a wide range of Prandtl numbers of 3.9 to 6.7 and Reynolds numbers of 500 to 11 200. The inlet temperature of the working fluid was maintained at an average of 20°C. The working fluid was circulated with two positive displacement pumps, one with a maximum volume flow rate of 1 344 l/h, which was used to pump the working fluid into the test section from a 1 000 l cold reservoir equipped with a 15 kW chiller unit and the other pump with a maximum volume flow rate of 270 l/h which was used to circulate the fluid from the exit of the test section to a chiller. A 1 l standard valve accumulator with a maximum volume flow rate of 14 000 l/h equipped with bladders containing air was installed to assist in the reduction of

pulsation associated with the electronically controlled positive displacement pump and to ensure constant pressure process.

Two coriolis flow meters were installed in parallel before the test section. One coriolis flow meter has a maximum volume flow rate of 108 ℓ/h ; this was used during measurement at low mass flow rate. The other coriolis flow meter has a maximum volume flow rate of 2 180 ℓ/h ; this was used during the high mass flow rate measurement. The working fluid flows through one of these flow meters at a time depending on the mass flow rate being considered.

Leaving the coriolis flow meter, the working fluid flows to the calming section and square-edge inlet section and then entered the test section. The water leaves the test section back into the 1 000 ℓ cold water reservoirs.

The diabatic friction factor was achieved by heating two electrically insulated wires with a wire diameter of 0.81 mm connected in parallel and coiled round the outer surface of the smooth copper tube.

The inlet and exit temperatures of the working fluids were measured with an aid of two PT100 probes installed. The inlet PT100 was installed at the mixing well of the calming section, the exit PT100 was installed at the exit mixing well after the test section. Each of these PT100s was calibrated with a thermobath before proceeding with the actual experiment and data collection. The tube was thereafter insulated with armafex insulating material. The overall thickness of insulation used was 0.144 m. With this insulation thickness, the heat loss during the experimentation was less than 1%.

On the test section was installed three pressure taps. This was achieved by drilling a hole of 1.6 mm through three 4.6 mm tubes soldered on the test section in the upward direction. The diameter of each of these holes drilled on the test section was ensured to be less than 10% of the inner diameter of the test tube. This decision was made to ensure that flow obstructions leading to eddy forming that will affect the values pressure drops at the taps within the test tube do not occur. The first pressure tap was placed at about 100 mm from the entrance of the test section, the second tap was located at about 2 350 mm from the first tap and the third pressure tap was installed at a distance of 2 450 mm from the second tap. The purpose of the first two taps was for the measurement of the pressure drops in the developing region, while the fully developed flow pressure drops were measured from the second and third pressure taps. Only the adiabatic and diabatic friction factors for the fully developed results are presented in this paper. The pressure drop between these two pressure taps were measured with the aid of pressure transducer equipped with a diaphragm of 1.4 kPa diaphragm.

A comprehensive uncertainty analysis was carried out on the all the variables considered during the experimentation and data reduction as the square root of the sum of the square of the bias and the precision. The bias was taken as the instrumentation uncertainty provided by manufacturers, while the precision was calculated according to the suggestions of Dunn [25]. The precision was calculated for each of the instrumentation from a sample data containing 400 data points as the product of standard deviation of the points and student's variable at 95% confidence level. The uncertainties of the

minimum and maximum Reynolds numbers are 0.46% and 0.26%; and the uncertainties of the diabatic friction factors corresponding to the minimum and maximum Reynolds numbers are 60% and 1.5% respectively.

DATA REDUCTION

The Reynolds number in the heat exchanger was obtained from the specified mass flow rate measured from the flow meter, the inner diameter of the heat exchanger, the dynamic viscosity calculated at the bulk temperature of the working fluid and the cross sectional area of the test section. The Reynolds number is expressed as

$$Re = \frac{\dot{m}_f D_i}{\mu_f A_c} \quad (1)$$

The properties of the working fluid were calculated using the average (bulk) temperatures from the inlet and outlet PT100 probes as shown in Eqn. (2). A linear variation in the temperature of the working fluid from inlet to outlet was obtained when these diabatic measurements were conducted. This is in line with previous studies [7]. This bulk temperature was calculated using

$$T_b = T_i + \left[\frac{T_e - T_i}{L_h} \right] * x \quad (2)$$

The properties of the working fluid calculated are the density, the dynamic viscosity, the specific heat capacity and the thermal conductivity. These properties were calculated according the mathematical expressions published by Popiel and Wojtkowiak [26].

Then the friction factors, which is a function of the inner diameter of the test section, the pressure drops, the length of the pressure drop, the density of the working fluid and the square of the velocity of flow were then calculated using the Darcy-Welsbach equation

$$f = \frac{2D_i \Delta p}{\rho L_{\Delta p} U_m^2} \quad (3)$$

VALIDATION WITH PREVIOUS STUDIES

The results of the present experimental data were compared with some available correlations in the laminar and turbulent flow regimes.

The diabatic friction factors, the laminar result of this present study were compared with the correlations of Ghajar and Madon [8] and Test [27]. The turbulent results were compared with equations of Blasius [7] and Allen and Eckert [28].

The validation results of the non-isothermal friction factors for the fully developed region with square-edge inlet configuration in smooth tube are presented in Figure 2. This fully developed length was 2.45 m from the end of the test section. This presents the pressure drops between the second and the third pressure taps. The range of Reynolds number considered was from 1 300 to 11 200. The Prandtl number also

varied from 4.56 to 6.66 as a result of the application of heat and increase in the difference between the inlet and the exit temperatures of the working fluid.

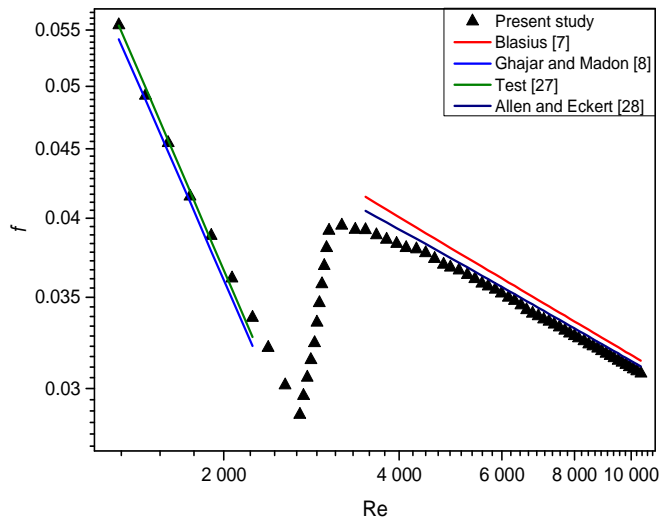

Figure 2 Diabatic friction factors for smooth circular tube with square-edge inlet in the fully developed region at the heat flux of 2 kW/m^2

In the laminar flow region, the diabatic results were compared with the correlations of Ghajar and Madon [8] and Test [27]. The minimum and maximum absolute deviations obtained between the present experimental data and these two correlations are 0.07% and 4.7% respectively.

Transition commenced at the Reynolds number of 2 700 and progressed the Reynolds number of 3 187 was reached, signifying the beginning of turbulence.

The diabatic friction factor data in the turbulent flow regime is compared with the correlation of Blasius [7] and Allen and Eckert [28]. The results show that the present data are in excellent agreement with these correlations.

RESULTS

The results of the diabatic friction factors of the tube with twisted tape insert at the heat flux of 2 kW/m^2 are shown in Figure 3. This result is also compared with the friction factor correlations of Manglik and Bergles [29] developed under constant wall temperature boundary condition.

Although the absence of discontinuity as compared with smooth tubes of the transition from laminar to turbulent in the diabatic friction factors of heat exchangers equipped with twisted tape insert is evident in Figure 3, the two criteria used in this paper provide the distinction between the laminar, transitional and turbulent flow regimes. The first criterion was the fluctuations in the 400 pressure drop data over a period of 20 s. The peak-to-peak amplitude or the change of the magnitude of the difference of the pressure drop patterns over the period of the 20 s in the transitional flow regime is higher compared to that of laminar and turbulent flow regimes. The second criterion is linear curve fitting at different Reynolds

numbers. The curve of the present data as shown in Figure 3 on a log-log scale is a polynomial of order 5 with adjustable R-Square value of 0.99993.

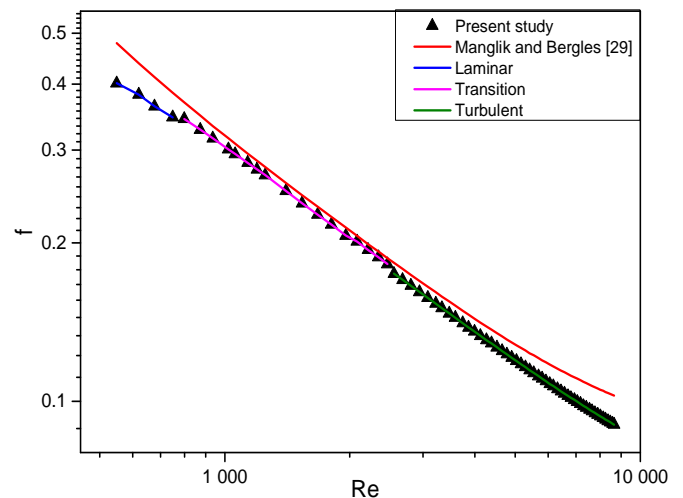

Figure 3 Diabatic friction factors for circular tube with twisted tape inserts and square-edge inlet in the fully developed region at the heat flux of 2 kW/m^2

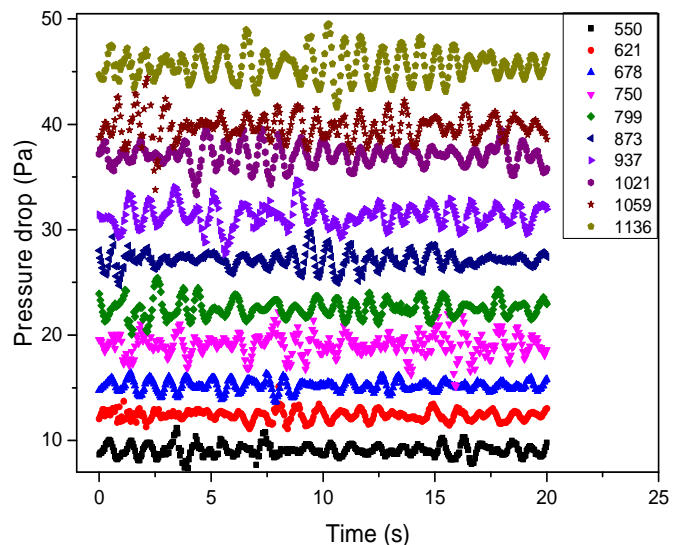

Figure 4 Pressure drops of the diabatic friction factors for circular tube with twisted tape inserts and square-edge inlet in the fully developed laminar and transitional flow regimes at the heat flux of 2 kW/m^2

Linear curve fit carried out on the diabatic friction factor shows the three different flow regimes. The results show that the laminar, transitional and turbulent flow regimes do not have the same gradient even though the adjusted R-Square values were very close to unity.

The laminar flow regime was fitted with four data points with slope and adjusted R-Square of -0.4872 and 0.99284 respectively. The pressure drops measured against time as

shown in Figure 4, for the laminar regime from the Reynolds number of 550 to 678 are relatively steady.

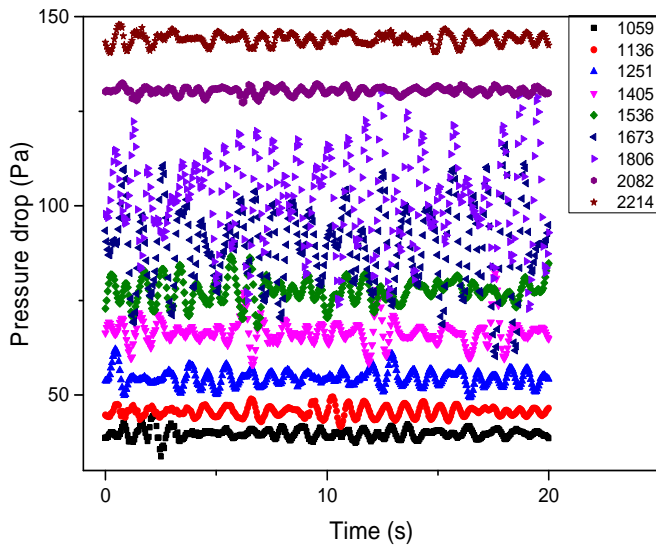

Figure 5 Pressure drops of the diabatic friction factors for circular tube with twisted tape inserts and square-edge inlet in the fully developed transitional and turbulent flow regimes at the heat flux of 2 kW/m^2

The transitional flow regime contains 14 data points. The slope and adjusted R-Square of this regime are -0.569 and 0.99958 respectively. The fluctuation of the pressure drop in an unsteady manner started at the Reynolds number of 750 as shown in Figure 4 and continued up to a Reynolds number of 2 082, as presented in Figure 5, where the steadiness of the pressure drops with time continues.

The pressure fluctuations inside the heat exchanger tube with twisted tape insert presented in the Figure 4 and Figure 5 signify the region of transition from the laminar to turbulent flow regime. In the transitional flow regime, this peak-to-peak pattern in the amplitude of the pressure drop against time is more noticeable compared to the laminar and turbulent flow regimes. This is also similar to the pressure drop characteristics in smooth heat exchanger tubes in the transitional flow regime.

In the turbulent flow regime, 53 data points were recorded. The gradient and adjusted R-Square of the linear curve used in this regime are -0.554 and 0.999 respectively. In Figure 5, the turbulent flow regime shows the steadiness of pressure drops with time continued as the Reynolds numbers increased and were not scattered as observed in the transitional flow regime.

CONCLUSION

In this paper, an experimental investigation of the influence of square-edge inlet section on the commencement of critical Reynolds numbers inside a smooth tube with twisted tape insert from laminar to turbulent was carried out and presented. The study provided new set of data for the diabatic friction factors with water as working fluid. Two criteria of pressure drop fluctuation and linear curve fitting have been used to distinguish the three flow regimes.

The possibility of the present data in the transitional flow regime indicate that, heat exchangers found in different applications today can now be enhanced with twisted tape inserts and be operated in this regime efficiently. The pressure drops in this flow regime are lower compared with that of the turbulent flow regime. This reduction translates to lower energy consumption of pumps being used to transport the working fluid through the heat exchanger and also the associated energy costs. This shows an effective way of reducing pressure drop in heat exchangers. Designing and operating heat exchangers in the transitional flow regime will help in the advancement of energy management.

ACKNOWLEDGEMENT

The authors appreciate the sponsorship received from the following institutions and organizations throughout the period of the experimentation. These institutions are National Research Foundation (NRF), University of Pretoria's IRT on Energy, the Solar Hub between Stellenbosch University and University of Pretoria supported by the Department of Science and Technology, the TESP programme of Eskom, NAC, EEDSH Hub of the University of Pretoria and the CSIR.

REFERENCES

- [1] J. P. Meyer and J. A. Olivier, "Heat transfer and pressure drop characteristics of smooth horizontal tubes in the transitional flow regime," *Heat Transfer Engineering*, vol. 35, pp. 1246-1253, 2014/10/13 2014.
- [2] S. Liu and M. Sakr, "A comprehensive review on passive heat transfer enhancements in pipe exchangers," *Renewable and Sustainable Energy Reviews*, vol. 19, pp. 64-81, 2013.
- [3] Z. Zhang, D. Ma, X. Fang, and X. Gao, "Experimental and numerical heat transfer in a helically baffled heat exchanger combined with one three-dimensional finned tube," *Chemical Engineering and Processing: Process Intensification*, vol. 47, pp. 1738-1743, 2008.
- [4] S. Rozzi, R. Massini, G. Paciello, G. Pagliarini, S. Rainieri, and A. Trifir, "Heat treatment of fluid foods in a shell and tube heat exchanger: Comparison between smooth and helically corrugated wall tubes," *Journal of Food Engineering*, vol. 79, pp. 249-254, 2007.
- [5] N. T. Obot, E. B. Esen, and T. J. Rabas, "The role of transition in determining friction and heat transfer in smooth and rough passages," *International Journal of Heat and Mass Transfer*, vol. 33, pp. 2133-2143, 1990.
- [6] Ashrae, *Fluid flow, ASHRAE Handbook - Fundamentals, American Society of Heating, Refrigerating and Air-Conditioning Engineers, Inc., Atlanta* vol. 30329, 2009.
- [7] A. Y. Cengel, *Heat & mass transfer: Fundamentals & applications, chapter 8: Internal forced convection*, 3rd Edn ed.: McGraw-Hill, 2006.
- [8] A. J. Ghajar and K. F. Madon, "Pressure drop measurements in the transition region for a circular tube with three different inlet configurations," *Experimental Thermal and Fluid Science*, vol. 5, pp. 129-135, 1992.

- [9] A. J. Ghajar and L. M. Tam, "Flow regime map for a horizontal pipe with uniform wall heat flux and three inlet configurations," *Experimental Thermal and Fluid Science*, vol. 10, pp. 287-297, 1995.
- [10] H. K. Tam, L. M. Tam, and A. J. Ghajar, "Effect of inlet geometries and heating on the entrance and fully-developed friction factors in the laminar and transition regions of a horizontal tube," *Experimental Thermal and Fluid Science*, vol. 44, pp. 680-696, 2013.
- [11] L. M. Tam and A. J. Ghajar, "Effect of inlet geometry and heating on the fully developed friction factor in the transition region of a horizontal tube," *Experimental thermal and fluid science*, vol. 15, pp. 52-64, 1997.
- [12] J. Dirker, J. P. Meyer, and D. V. Garach, "Inlet flow effects in micro-channels in the laminar and transitional regimes on single-phase heat transfer coefficients and friction factors," *International Journal of Heat and Mass Transfer*, vol. 77, pp. 612-626, 10// 2014.
- [13] J. P. Meyer, T. J. McKrell, and K. Grote, "The influence of multi-walled carbon nanotubes on single-phase heat transfer and pressure drop characteristics in the transitional flow regime of smooth tubes," *International Journal of Heat and Mass Transfer*, vol. 58, pp. 597-609, 2013.
- [14] J. A. Olivier and J. P. Meyer, "Single-phase heat transfer and pressure drop of the cooling of water inside smooth tubes for transitional flow with different inlet geometries (RP-1280)," *HVAC and R Research*, vol. 16, pp. 471-496, 2010.
- [15] A. J. Ghajar and L. M. Tam, "Laminar-transition-turbulent forced and mixed convective heat transfer correlations for pipe flows with different inlet configurations," presented at the Winter Annual Meeting of the American Society of Mechanical Engineers, 1991.
- [16] L.-M. Tam and A. J. Ghajar, "The unusual behavior of local heat transfer coefficient in a circular tube with a bell-mouth inlet," vol. 16, pp. 187-194, 1998.
- [17] J. P. Meyer, L. Liebenberg, and J. A. Olivier, "Measurement and evaluation of single-phase heat transfer and pressure drop inside enhanced tubes for transition flow," *ASHRAE (American Society of Heating, Refrigerating and Air-Conditioning Engineers, Report nr: 1280-RP)*, , p. 204, 2008.
- [18] K. Wongcharee and S. Eiamsa-ard, "Friction and heat transfer characteristics of laminar swirl flow through the round tubes inserted with alternate clockwise and counter-clockwise twisted-tapes," *International Communications in Heat and Mass Transfer*, vol. 38, pp. 348-352, 2011.
- [19] S. W. Hong and A. E. Bergles, "Augmentation of laminar flow heat transfer in tubes by means of twisted-tape inserts," *Journal of Heat Transfer*, vol. 98, pp. 251-256, 1976.
- [20] A. W. Date, "Prediction of fully-developed flow containing a twisted-tape," *International journal of heat and mass transfer*, vol. 17, pp. 845-859, 1974.
- [21] A. W. Date and U. N. Gaitonde, "Development of correlations for predicting characteristics of laminar flow in a tube fitted with regularly spaced twisted-tape elements," *Experimental Thermal and Fluid Science*, vol. 3, pp. 373-382, 1990.
- [22] P. Murugesan, K. Mayilsamy, S. Suresh, and P. S. S. Srinivasan, "Heat transfer and pressure drop characteristics in a circular tube fitted with and without V-cut twisted tape insert," *International Communications in Heat and Mass Transfer*, vol. 38, pp. 329-334, 2011.
- [23] R. M. Manglik and A. E. Bergles, "Heat transfer enhancement and pressure drop in viscous liquid flows in isothermal tubes with twisted-tape inserts," *Wärme- und Stoffübertragung*, vol. 27, pp. 249-257, 1992.
- [24] R. M. Manglik and A. E. Bergles, "Heat transfer and pressure drop correlations for twisted-tape inserts in isothermal tubes: Part I—laminar flows," *Journal of Heat Transfer*, vol. 115, pp. 881-889, 1993.
- [25] P. F. Dunn, *Measurement and data analysis for engineering and science*, 2nd edn. ed. New York, USA: CRC Press, Taylor and Francis Group, Boca Raton, 2010.
- [26] C. O. Popiel and J. Wojtkowiak, "Simple formulas for thermophysical properties of liquid water for heat transfer calculations (from 0°C to 150°C)," *Heat Transfer Engineering*, vol. 19, pp. 87-101, 1998.
- [27] F. L. Test, "Laminar flow heat transfer for fluids and liquids with temperature-dependent viscosity," *Journal of Heat Transfer*, vol. 90, pp. 385-393, 1968.
- [28] R. W. Allen and E. R. G. Eckert, "Friction and Heat-Transfer Measurements to Turbulent Pipe Flow of Water ($Pr=7$ and 8) at Uniform Wall Heat Flux," *Journal of Heat Transfer*, vol. 86, pp. 301-310, 1964.
- [29] R. M. Manglik and A. E. Bergles, "Characterization of twisted-tape-induced helical swirl flows for enhancement of forced convective heat transfer in single-phase and two-phase flows," *Journal of Thermal Science and Engineering Applications*, vol. 5, pp. 021010-1 - 021010-12, 2013.