

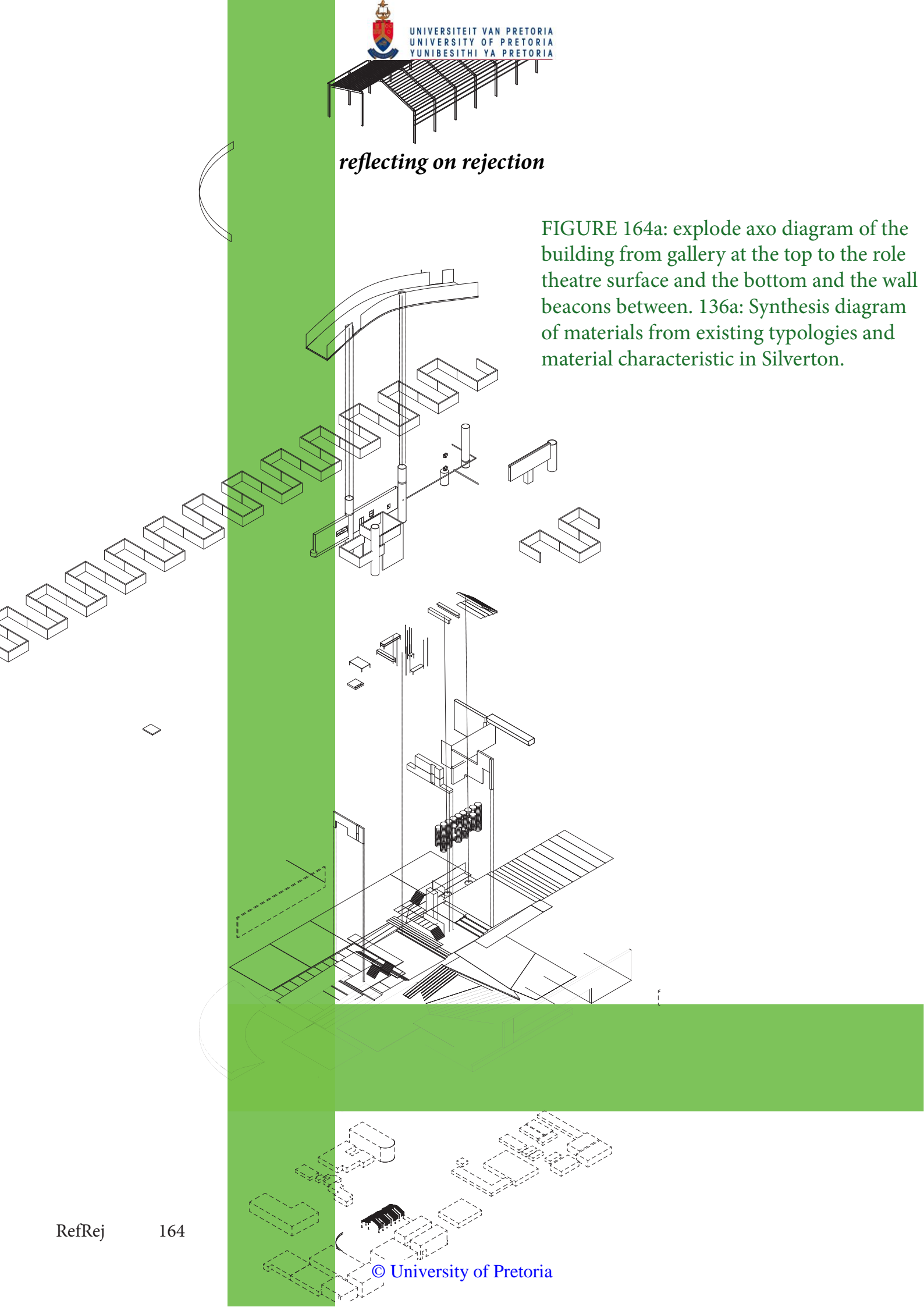

*reflecting on rejection*

FIGURE 164a: explode axo diagram of the building from gallery at the top to the role theatre surface and the bottom and the wall beacons between. 136a: Synthesis diagram of materials from existing typologies and material characteristic in Silverton.





# 09. SYLLOGISM

## SYNTHESIS OF EXCHANGE

The final site context creates its own inner courtyard that links with the health centres newly proposed sport facilities

Changes to the site area include the development of a low density shop into a commercial complex. The removal on a residential aspect that then becomes added to the artist residency and excludes the design of the community centre and the existing medical centre and the insertion of a new health centre,

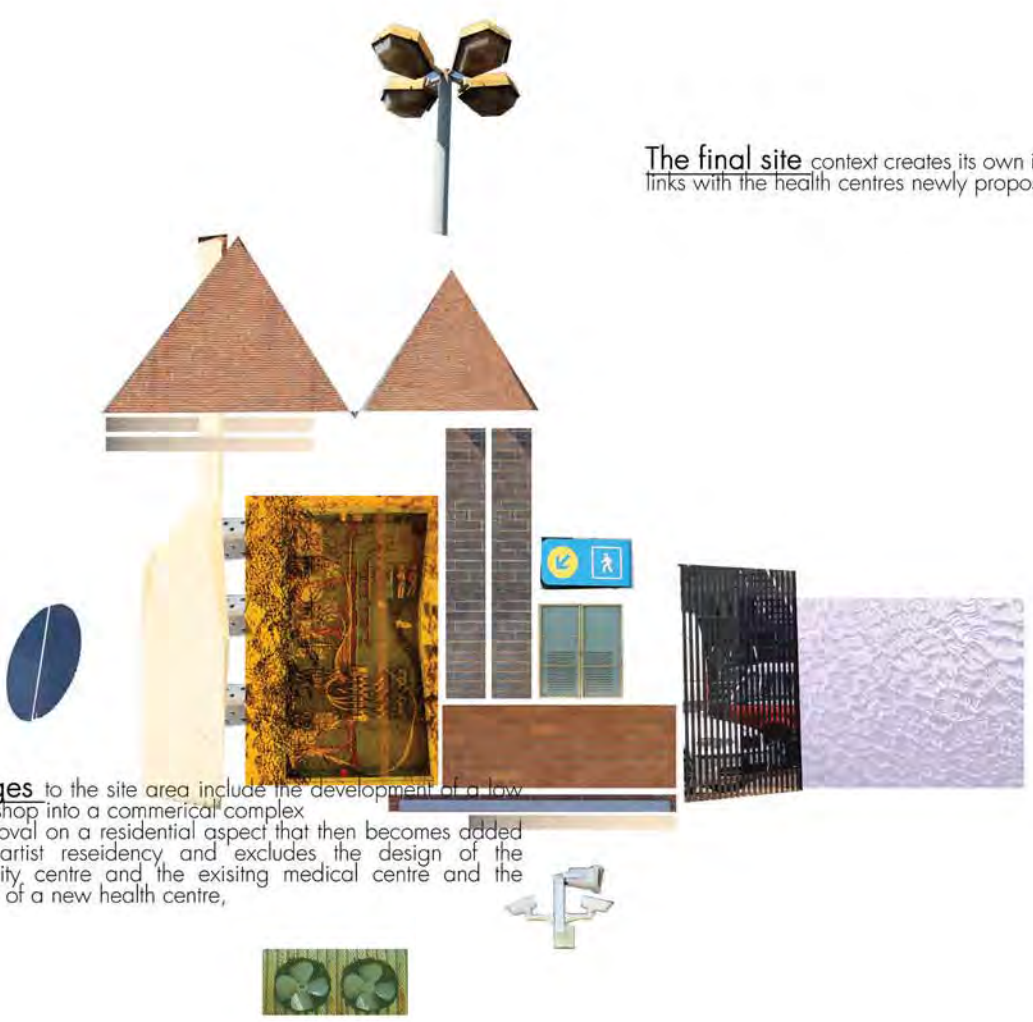

# TECTONIC ORDER



UNIVERSITEIT VAN PRETORIA  
UNIVERSITY OF PRETORIA  
YUNIBESITHI YA PRETORIA

transform

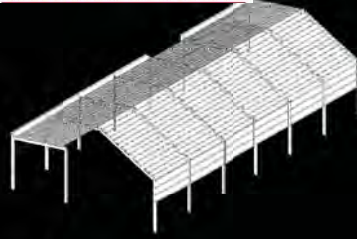

beacon



gallery  
onto



plastic  
column

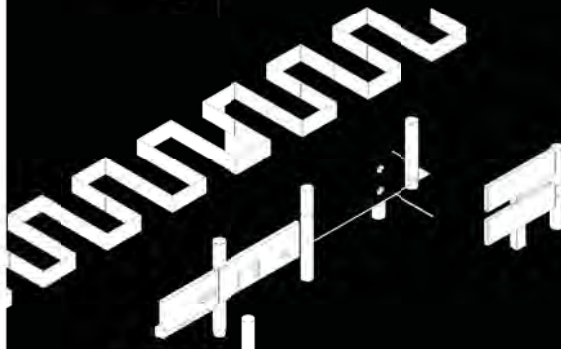

walls



role  
theatre

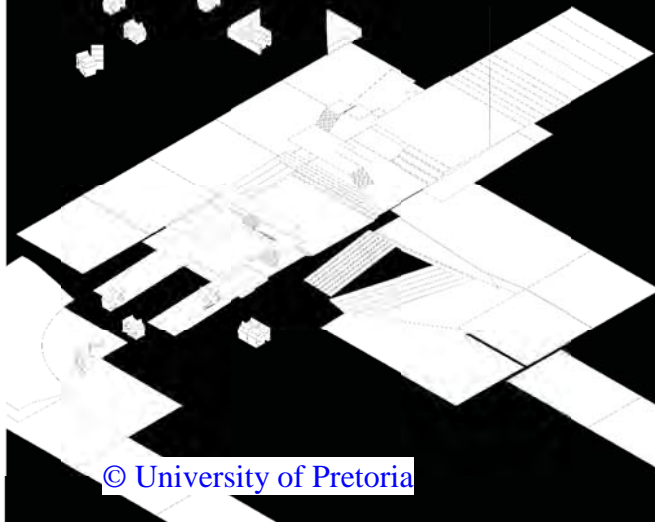

FIGURE  
166 Tectonic  
explosion of  
building as part  
of construction  
strategy

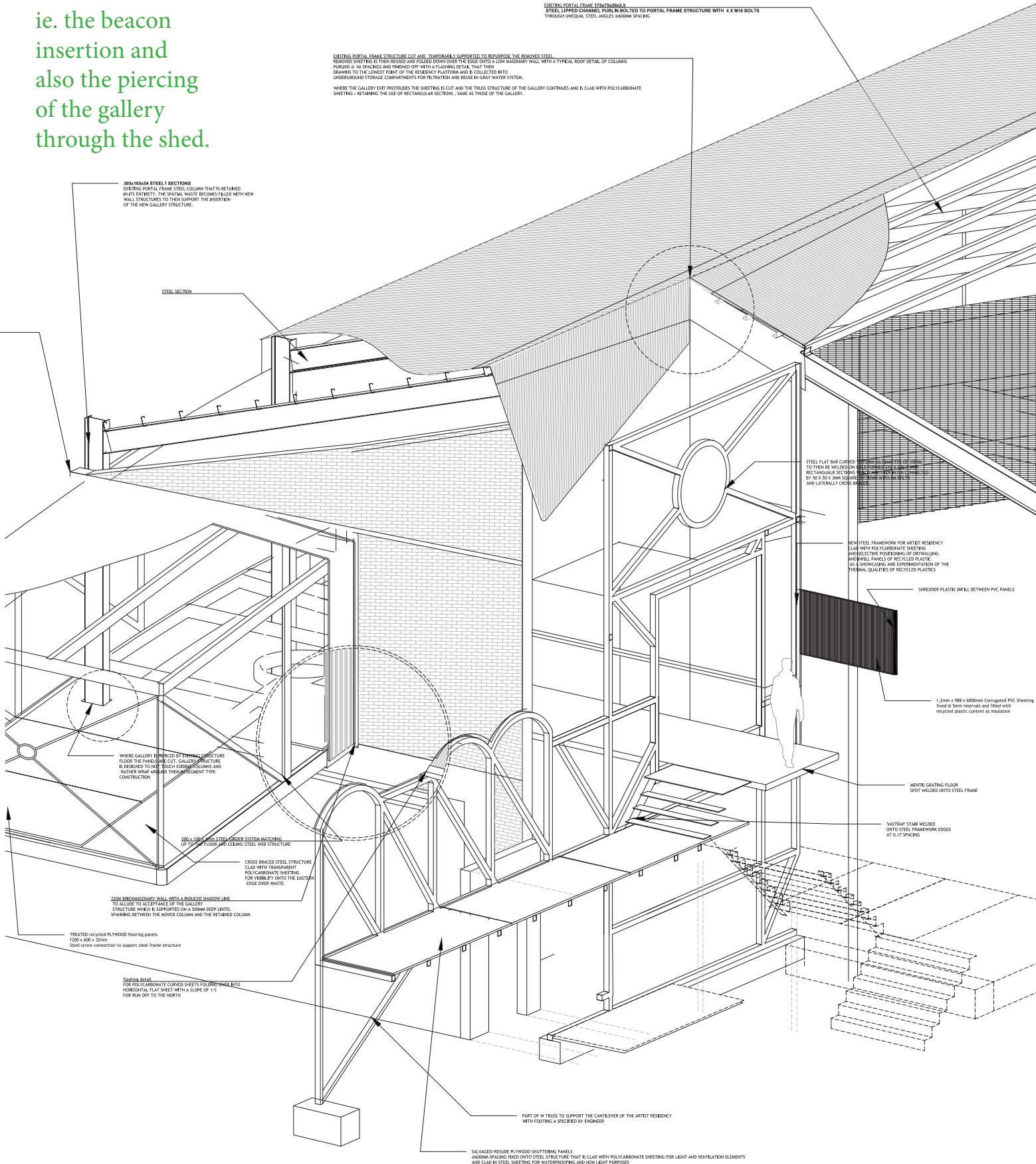

FIGURE 167  
The culmination  
of waste value  
through 3d axo  
detailing the  
moment of waste  
transformation  
ie. the beacon  
insertion and  
also the piercing  
of the gallery  
through the shed.

# THE BEACON

a culmination of values

1:20





## ' ARCHITECTURE IS WASTE IN TRANSIT ' PETER GUTHRIE

### *The Plastic Column*

Architecture continues to take on the interpretation of social, environmental and spatial issues. This dissertation situated itself within the issue of waste within all of the above and sought to explore and extrapolate an architecture of code ; codification of space according to social values relating to waste.

#### SOCIAL WASTE:

The context of Silverton is defined as the landscape of social waste - a place which is neither industrial nor suburban nor residential nor religious nor commercial yet all of the aforementioned. This is a context which is already facilitating the production of waste at all scales and all spectrums, yet this is also the space that is perceived as a wasteland - a buffer zone - an in between - a drive through - yet the author argues that this is this is the INVISIBLE DESTINATION - a spatial condition which the author argues, ART has the potential to transform and therefore the program of an art residency aims to facilitate the unfolding of spatial potential in a place - injecting event and information - the most consumed aspects of the everyday human existence - as a means of revealing potential and addressing the identified attitudes towards waste. Rejecting , reflecting and accepting waste value is what the architecture seeks to facilitation through the concepts of beacon, role theatre and frequency.

#### WASTE :

The material of waste was identified from the start as a valuable resource not only in terms of potential energies but as a generator for design decision making. Finally the material of plastic was selected as the material by which to explore design and structural potentials and make architecture for and from.

The plastic column [above iteration one] emerged - exploring what it meant to use a material associated strongly with waste [the pacific gyre] in architecture. Was it to be as image and representational ? Was it to be material ? The first plastic column existed as a luxurious and expensive extrusion of plastic - commenting on manufacturing methods and also the future of plastic - its structural development [grp profiles] as well as its more environmentally conscious development [Bioplastics].

However finally the plastic column manifests itself in the spatial exhibition of the TOILET> the space of human waste creation also the space most renowned for its waste of water. The architecture continued to explore how space can bring forth the needed dialogue relating to social, spatial and environmental issues - and instead of manifesting itself in material form concludes in doing so through spaces of facilitation of dialogue that can address narratives of waste culture.

#### SPATIAL WASTE:

The INVISIBLE DESTINATION as a spatial condition is that which has resulted in a dispersed and inconsistent collection of attitudes to value of waste - the building seeks to unify those into one place and seeks to also serve as typological formula for all places of this type of codified spatial condition. And so through the conceptual approaches spatial strategies were developed for an architectural response to come about.

The architecture is housed within an existing portal frame shed - lost transactional potential of a community serving suburban block - and as an approach to spatial waste the architecture transforms the shed slightly so that onto this INVISIBLE DESTINATION the BEACON can be housed.

#### THE BEACON:

The invisible destination has inserted into it the waste of its context in the form of an artist residency attached to a spatial condition.

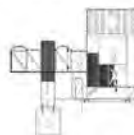

#### THE FREQUENCY:

The beacon now inserted into the invisible destination brings about a social activation of spatial waste through the gallery space, where art becomes the mediator between creation and destruction.

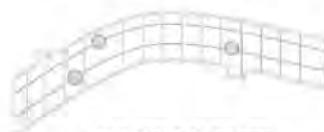

#### THE ROLE THEATRE:

The facilitation of dialogue between all attitudes of waste for the transformation of waste to occur of a non-physical level.





FIGURE 169  
Diagrammatic unpacking of theory, concepts and value onto the space. Beacon accepting waste on the eastern edges and through the gallery of frequency reflection of waste value then spatially concludes in the role theatre which rejects value stigmas through dialogue and opens to the west as a allusion to this excretion of waste concepts.

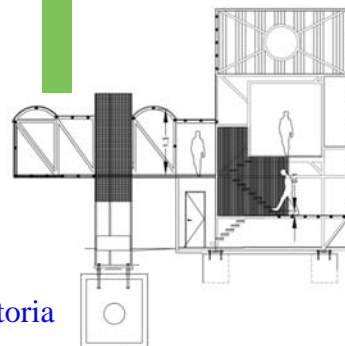
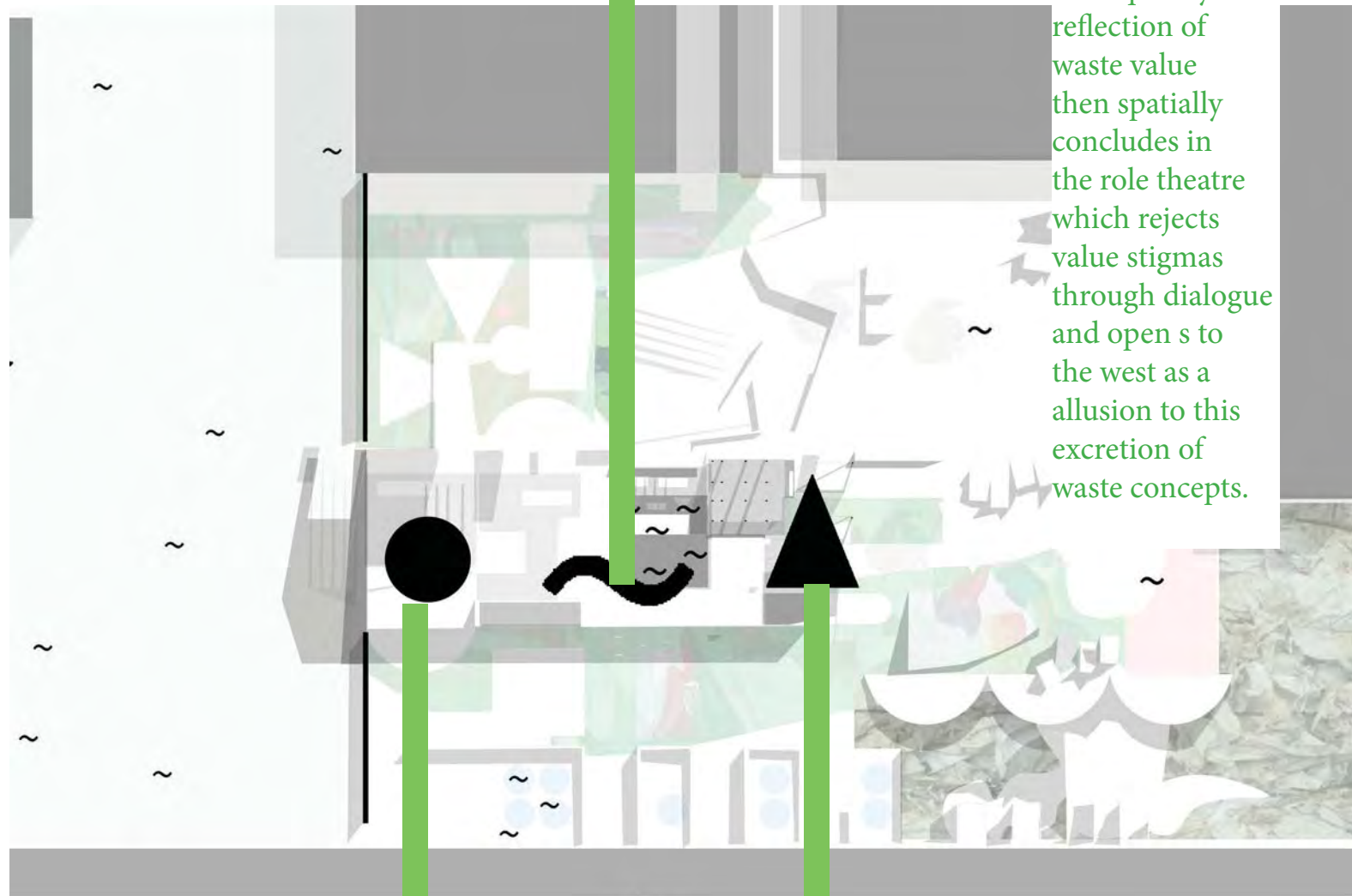



# AGGREGATE SYNTHESISING

AGGREGATE refers not only to the association to plastic shredding' physical attributes that resemble that of sand but also to the part of the construction, which is concrete.

Concrete has immense environmental consequences on water, considering that there is a legal requirement for it to be made with potable water, which entails in a world where access to water is a major concern, that a glass of water is taken away from a living being for the making of concrete. Man has allowed the process of making to non-directly affect another human being. Rather than ensure there is enough drinking water for the world, we are concerned about the water of an inanimate object. It may be argued that concrete in its finished form has the ability to then provide water - say it becomes a giant bucket to capture water with - when it rains, but by the time the rain should come, all the water reserves have been used to build concrete buckets- the scenario seems fictional but all things are when we consider the futures we imagine and have.

Aggregate then not only touches on the physical aspects of matter wasted, which has been an informant throughout this dissertation, but the notion of aggregate also refers to various parts and particles of this document. This includes the issues to the theories to the concepts all the way through to the design and material unpacking which now, in this final chapter of the synthesis of architecture, sees all the parts of a project mixed together to pour out the final sculpture of the building.

The plastic method of synthesising, abundant in the methods of doing so, also relates to the aggregate nature of elements of the built environment and also construction matter, such as concrete.

Thinking about the construction of the building which often comes too late and if anything this has been a slow process of discovering the language of

architecture. From the start the building wished to speak a language of the industrial typology, that being the initial reason for trying to reconstruct a second portal frame adjacent to the existing on, however later when then smallness was retained and controlled again it was simpler to let the industrial shed typology speak in juxtaposition, contrast and other linguistic methods to the insertion of the beacon and the frequencies and their relation to the role platform.

The technification of the building began like most things in this dissertation, a set of lines and abstract clouds on information that then through processes of drawing became balanced and grounded.

## ACCEPTING WASTE AS AGGREGATE FOR THE PURPOSE OF BEACON

### WASTE AS MATTER:

Walls constructed from polycarbonate and filled in with varieties of plastic waste and shreds.

## REFLECTION WASTE AS AGGREGATE FOR SOCIAL TRANSACTIONS RELATED TO FREQUENCY:

### WASTE AS PEOPLE

## REJECTING WASTE AS AGGREGATE FOR CONSTRUCTIONS OF THE ROLE THEATRE

### WASTE AS SPACE

Where waste is about language, consciousness and not the materiality. Other means of waste construction to be utilised. Like reused wood from concrete shuttering and a tire wall as a reference point of dialogue of other potentials of waste not specifically related to plastic, despite its relation to rubber.

### BEACON AGGREGATE; plastic

FIGURE 170a: Photograph of red shredded plastic. 138b: Sketches of potential lattice structures to exploit the movement potentials of aggregate, IMW

2016

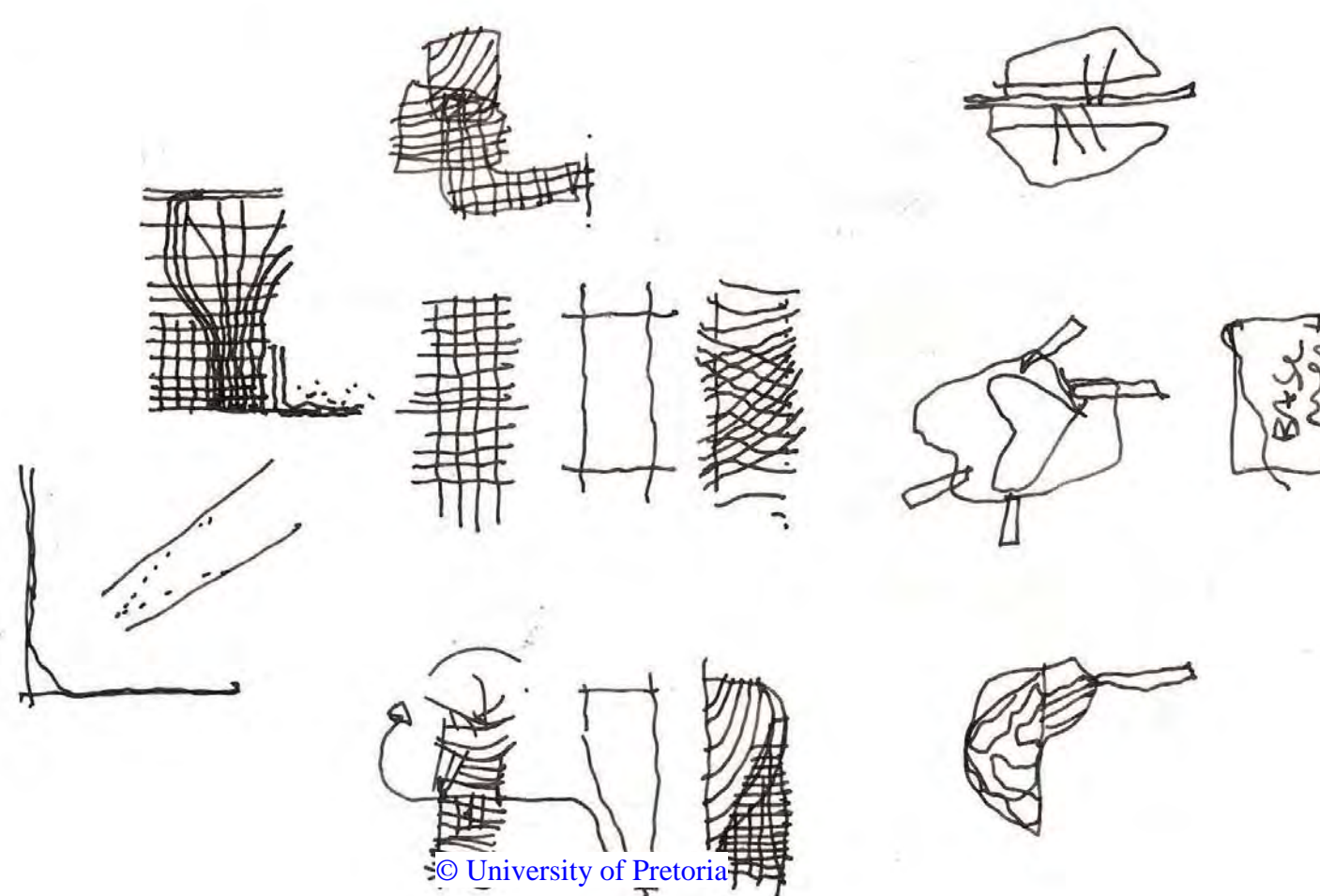
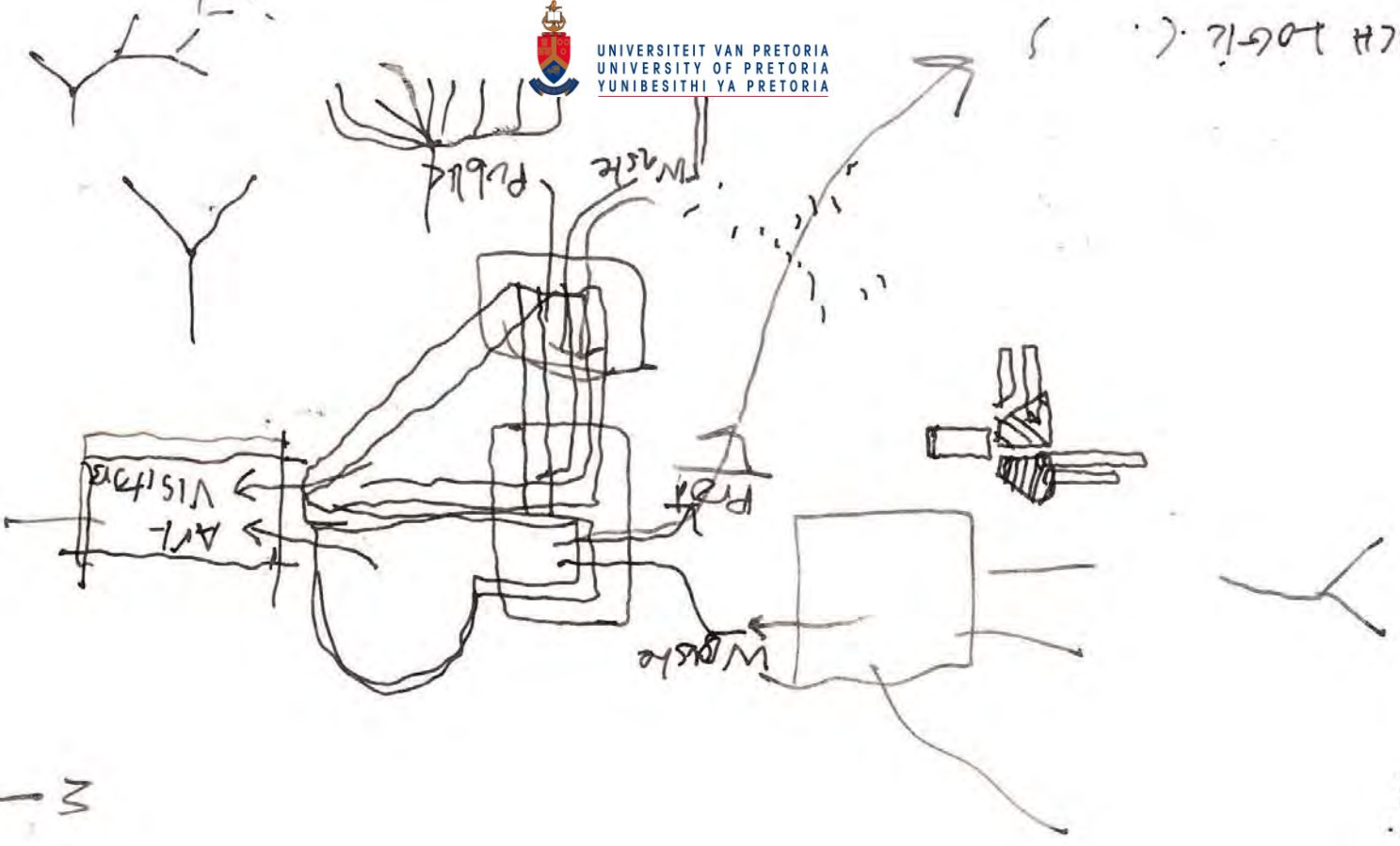



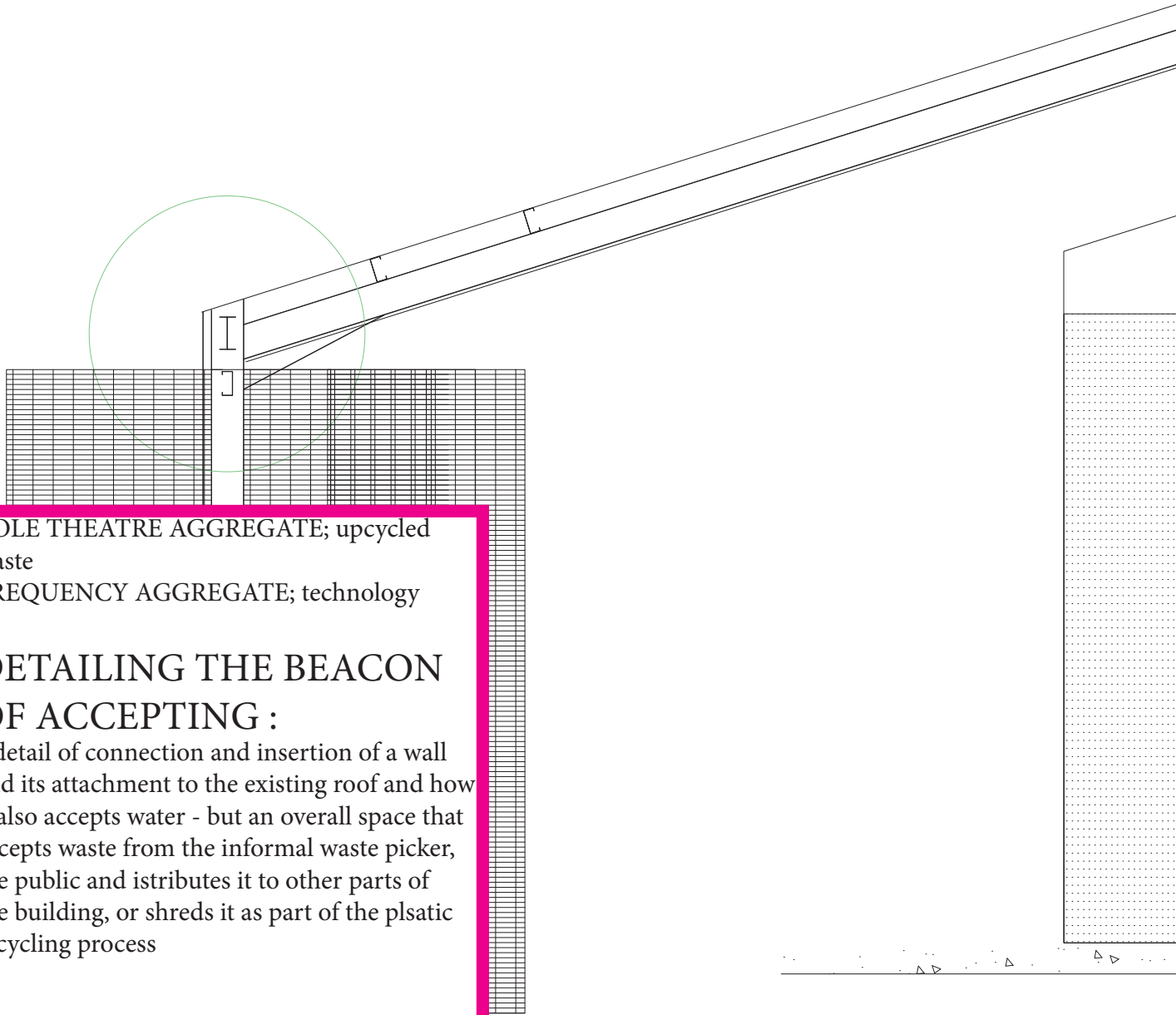

ROLE THEATRE AGGREGATE; upcycled waste  
FREQUENCY AGGREGATE; technology

### DETAILING THE BEACON OF ACCEPTING :

a detail of connection and insertion of a wall and its attachment to the existing roof and how it also accepts water - but an overall space that accepts waste from the informal waste picker, the public and distributes it to other parts of the building, or shreds it as part of the plastic recycling process

### DETAILING FREQUENCIES OF REFLECTION;

a detail of the moving components that adjust to alter space and its use. THE DOOR

### DETAILING ROLE THEATRES OF REJECTION;

the spaces of excretion, the toilets and also the dialogue halls tire wall construction in the ubuntu block fashion

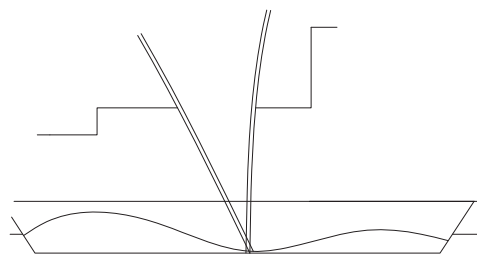
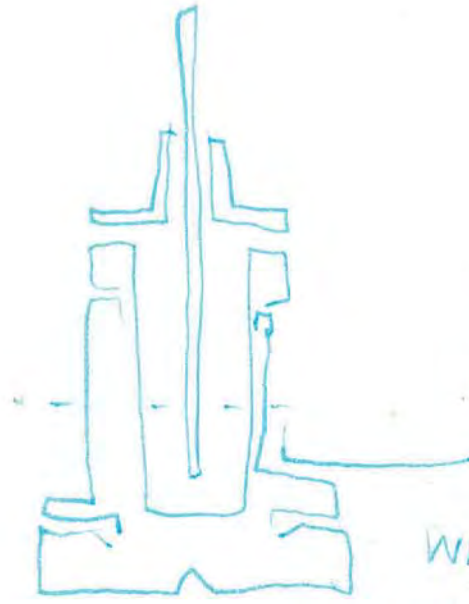
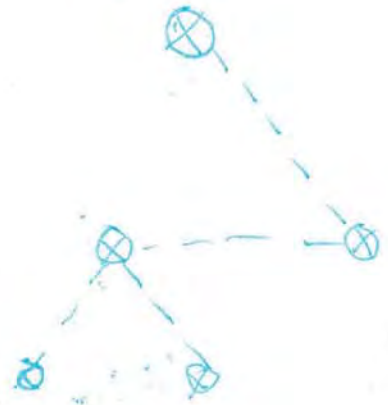

FIGURE 172: Details in progress by IMW 2016. Selection based on the intersection with old and new, giving spatial waste injections of energy.



light plan



windows

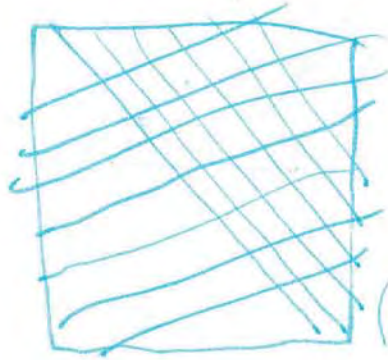

Rebar design

floor design  
(tile)

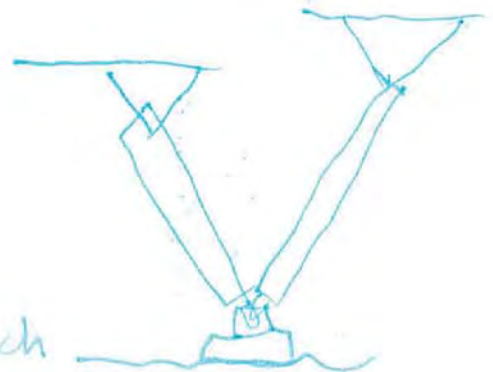
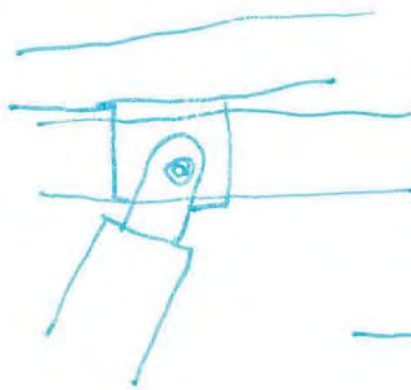

branch  
structure



# GROUND FLOOR PLAN

PUB  
PRE  
EXIS  
RESI

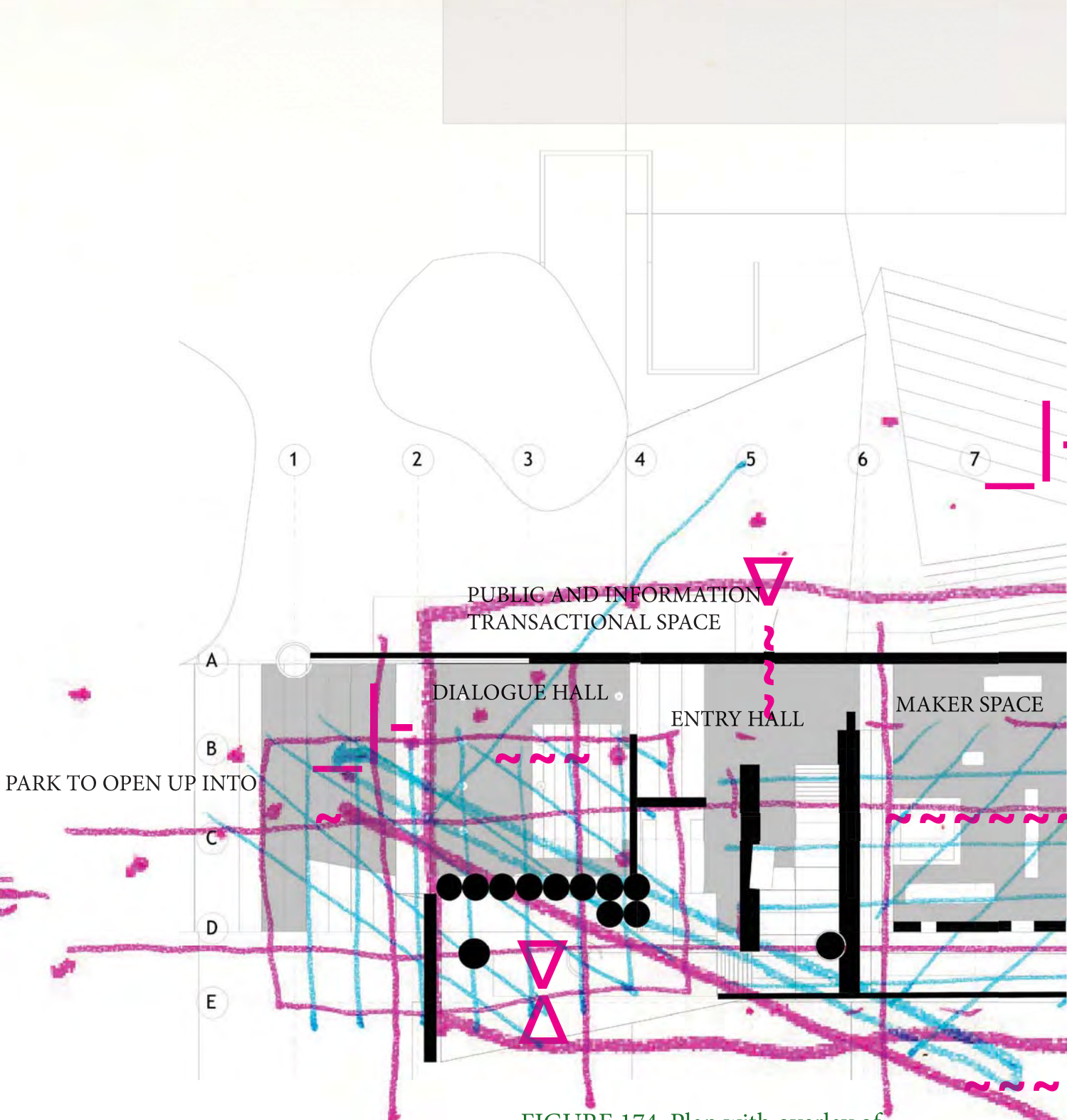
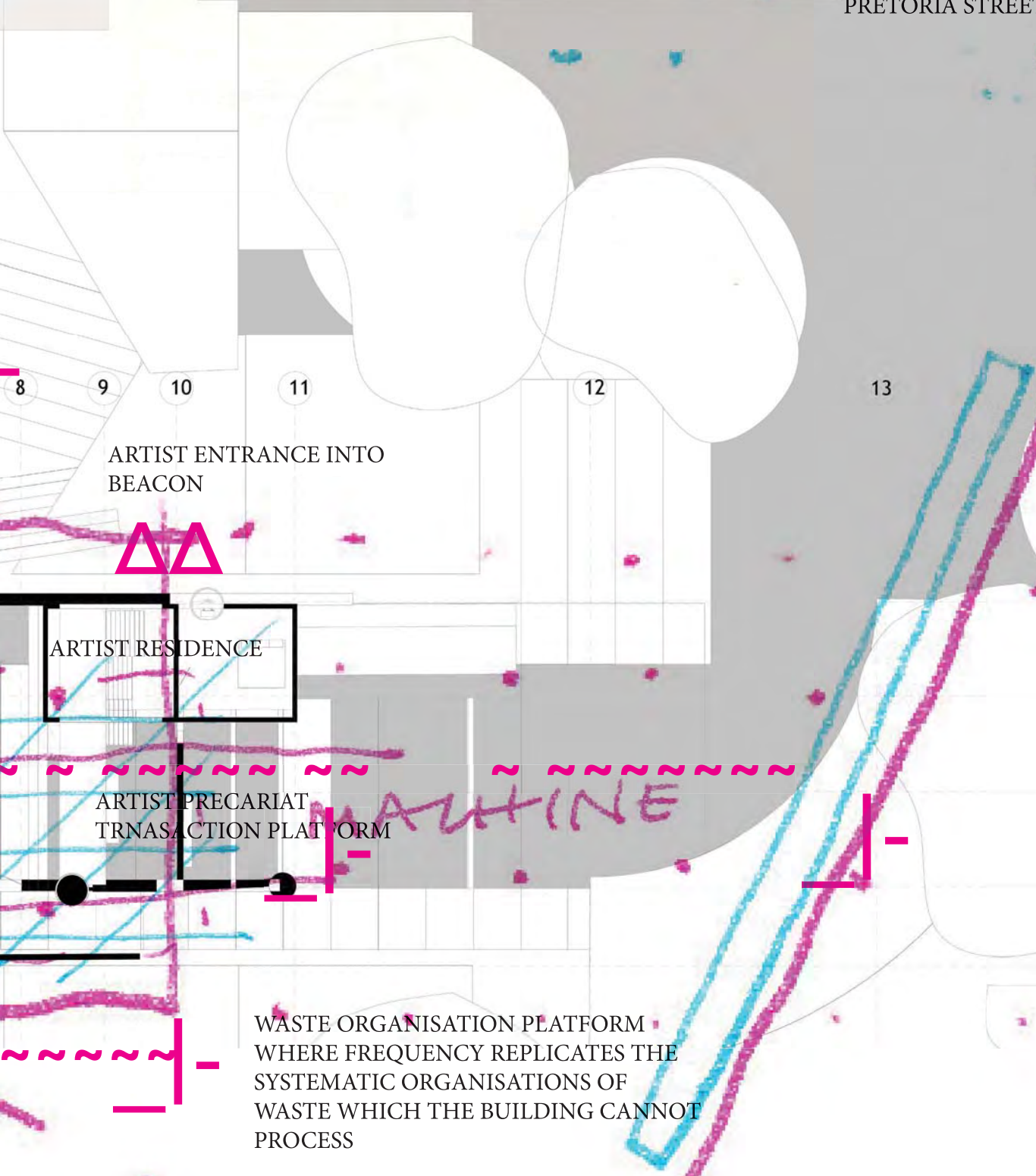

FIGURE 174: Plan with overlay of conceptual symbol language applied to spaces. Legend on following page.

PUBLIC ENTRANCE FROM  
PRETORIA STREET THROUGH  
EXISTING COMMERCIAL  
RESIDENTIAL BLOCK

WASTE ENTRANCE FROM  
PRETORIA STREET



ARTIST ENTRANCE INTO  
BEACON

ARTIST RESIDENCE

ARTIST PRECARIAT  
TRANSACTION PLATFORM

WASTE ORGANISATION PLATFORM  
WHERE FREQUENCY REPLICATES THE  
SYSTEMATIC ORGANISATIONS OF  
WASTE WHICH THE BUILDING CANNOT  
PROCESS



# LEGENDS OF CONCEPTS



Beacon drawing in, guiding in.



Beacon displaying outward,  
guiding around.



Beacon as indicator of entrance,  
gathering, arrival.



Frequency of frequency of waste  
and its linear devolution into  
thought.



Beacon guiding frequency,  
laserbeam like, disrupting the  
linear frequency of waste.



The role theatre, always a surface  
in relation to either frequency.

FIGURE 176: legend for conceptaul symbols  
and their intersections and collaborations  
that unpack how concepts will function  
architecturally.

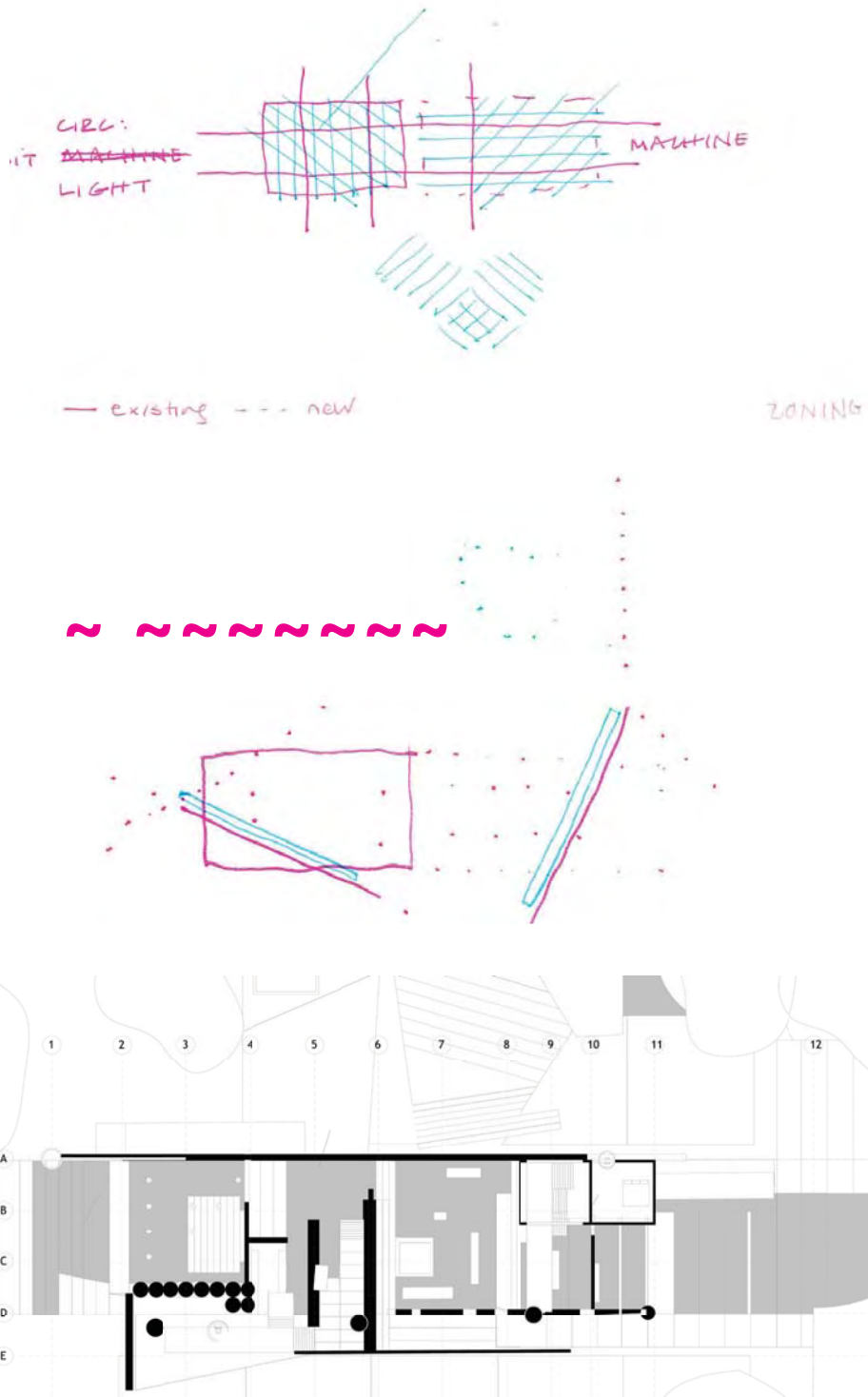

FIGURE 177: Layers of plan parts- Beacon : Roof structure lattice--- Role Theatre surface floor of public to waste intersection and finally the building that resonates all frequencies.

# GALLERY FLOOR PLAN WITH SYMBOLS

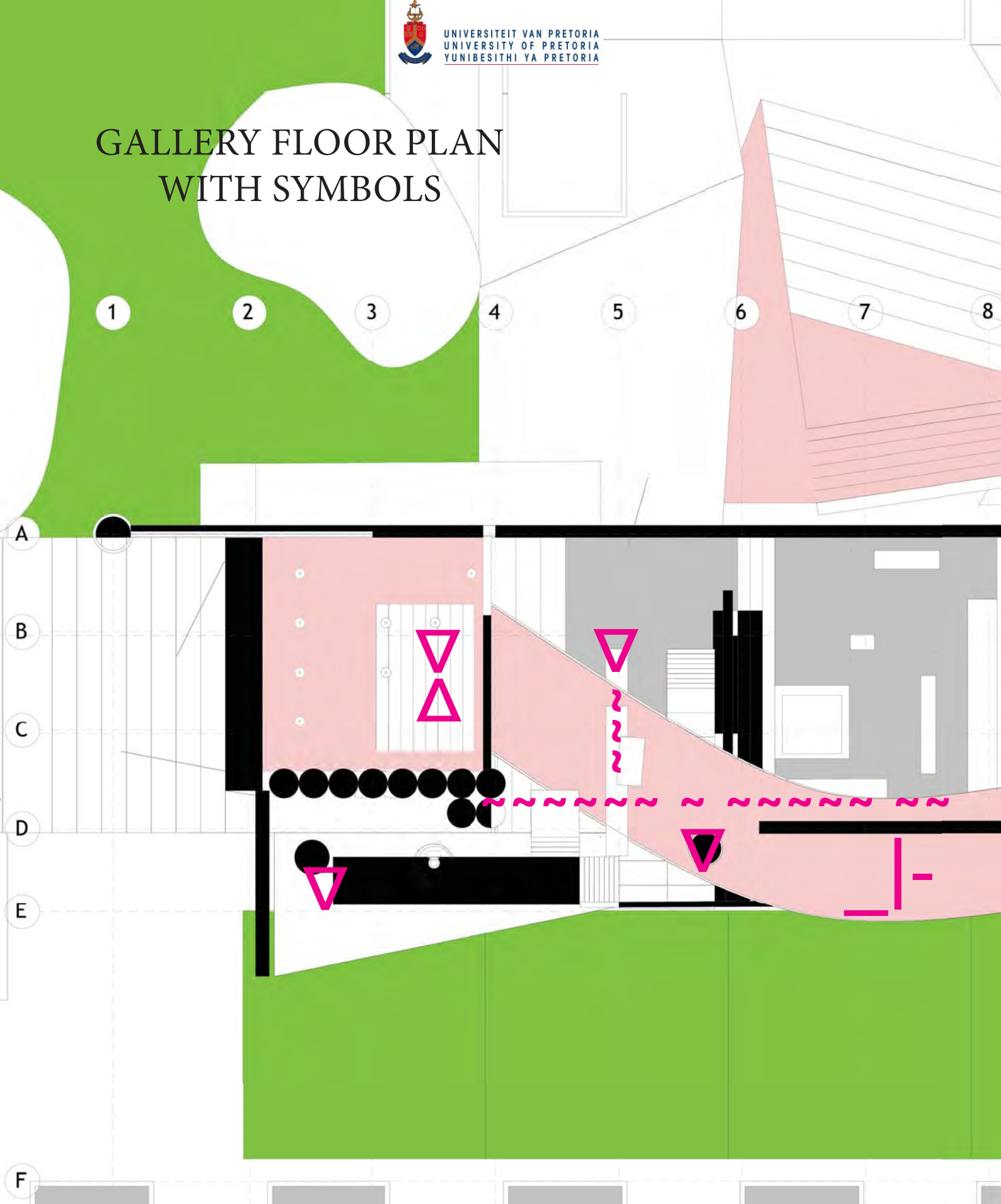
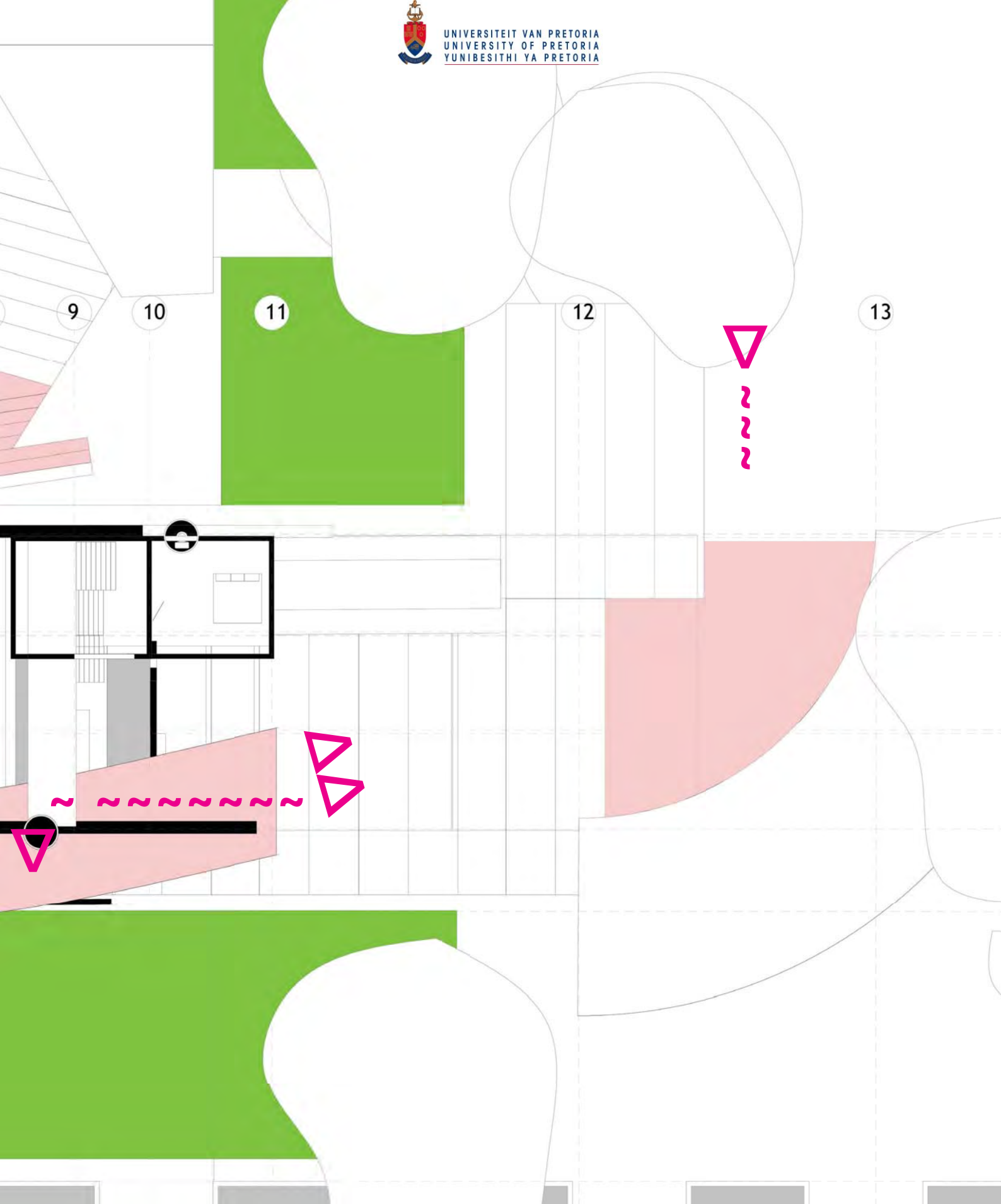

FIGURE 178: Second floor plan of spaces in relation to conceptual symbol language, IMW 2016.





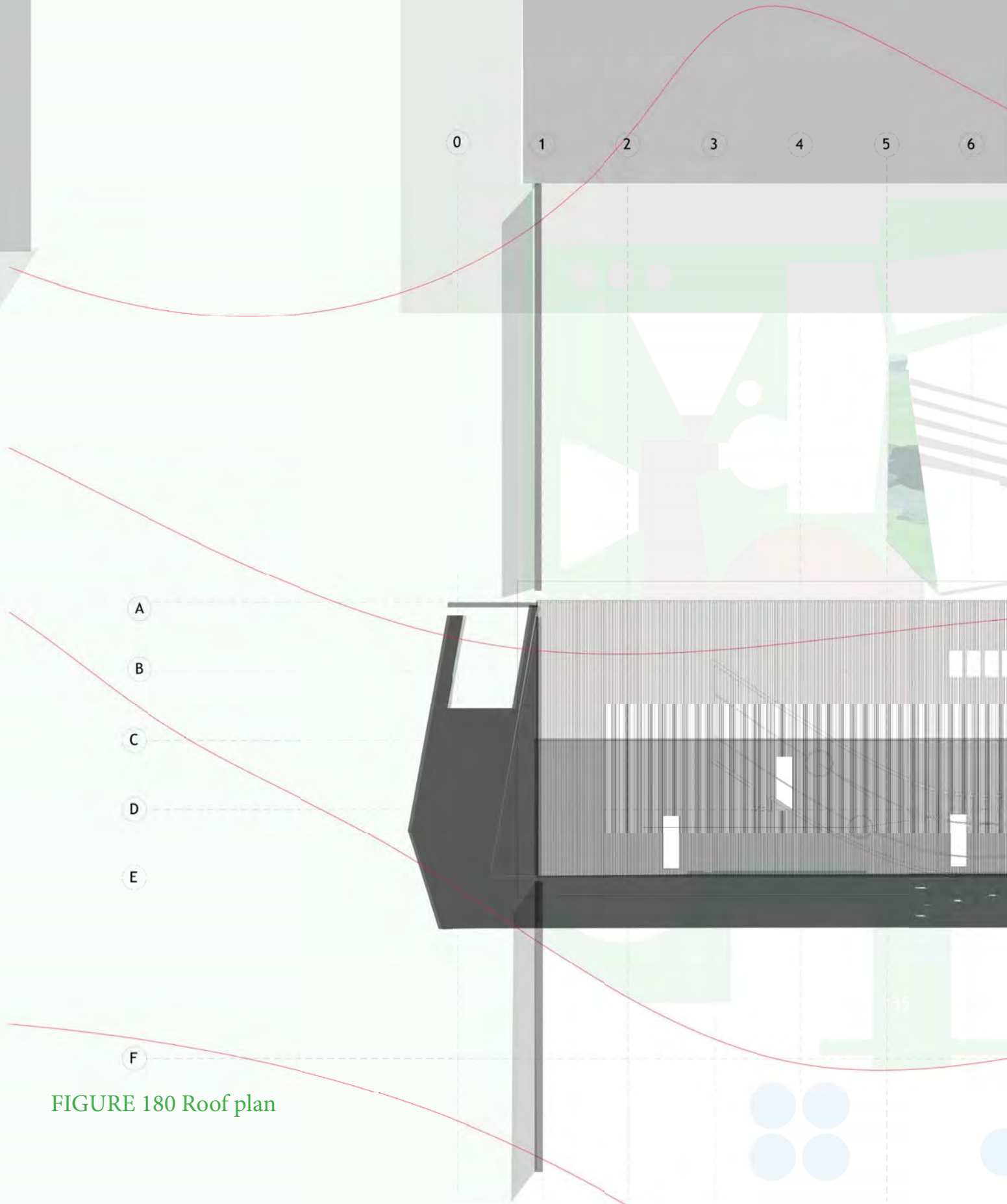

FIGURE 180 Roof plan

ROOF WATER PLAN : WA





ASOP 1:100

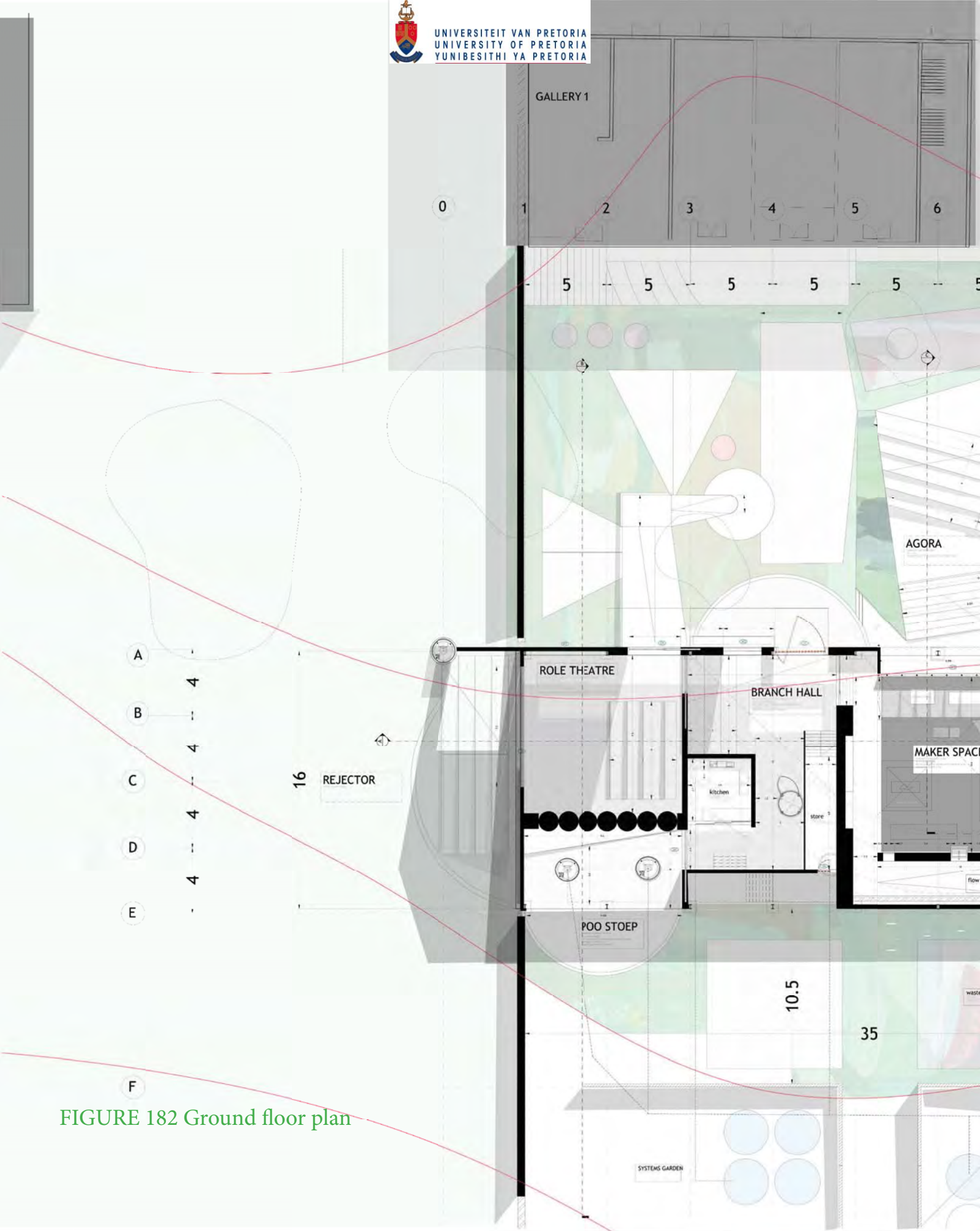
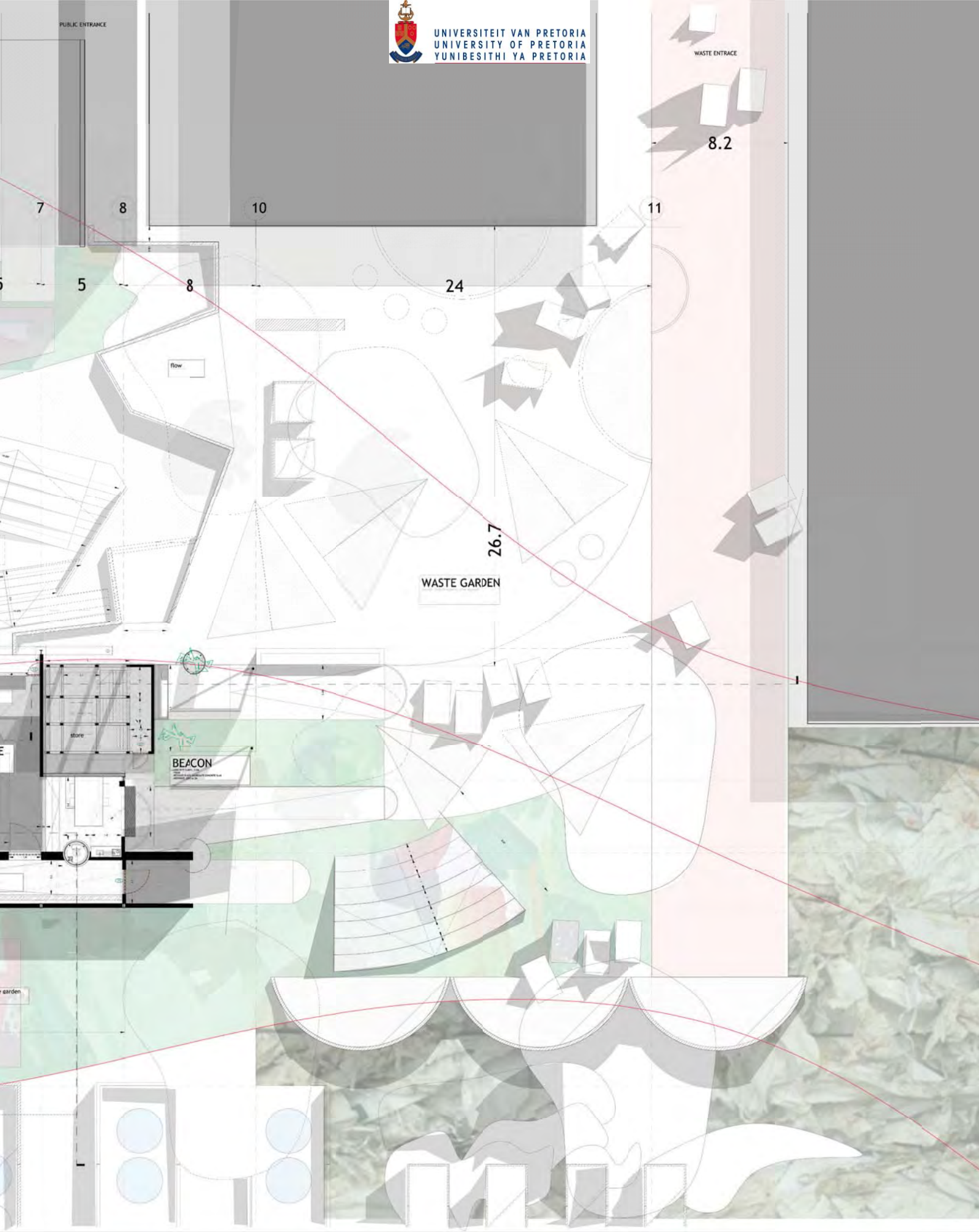

FIGURE 182 Ground floor plan

GROUND FLOOR PLAN : WASOP 1:100





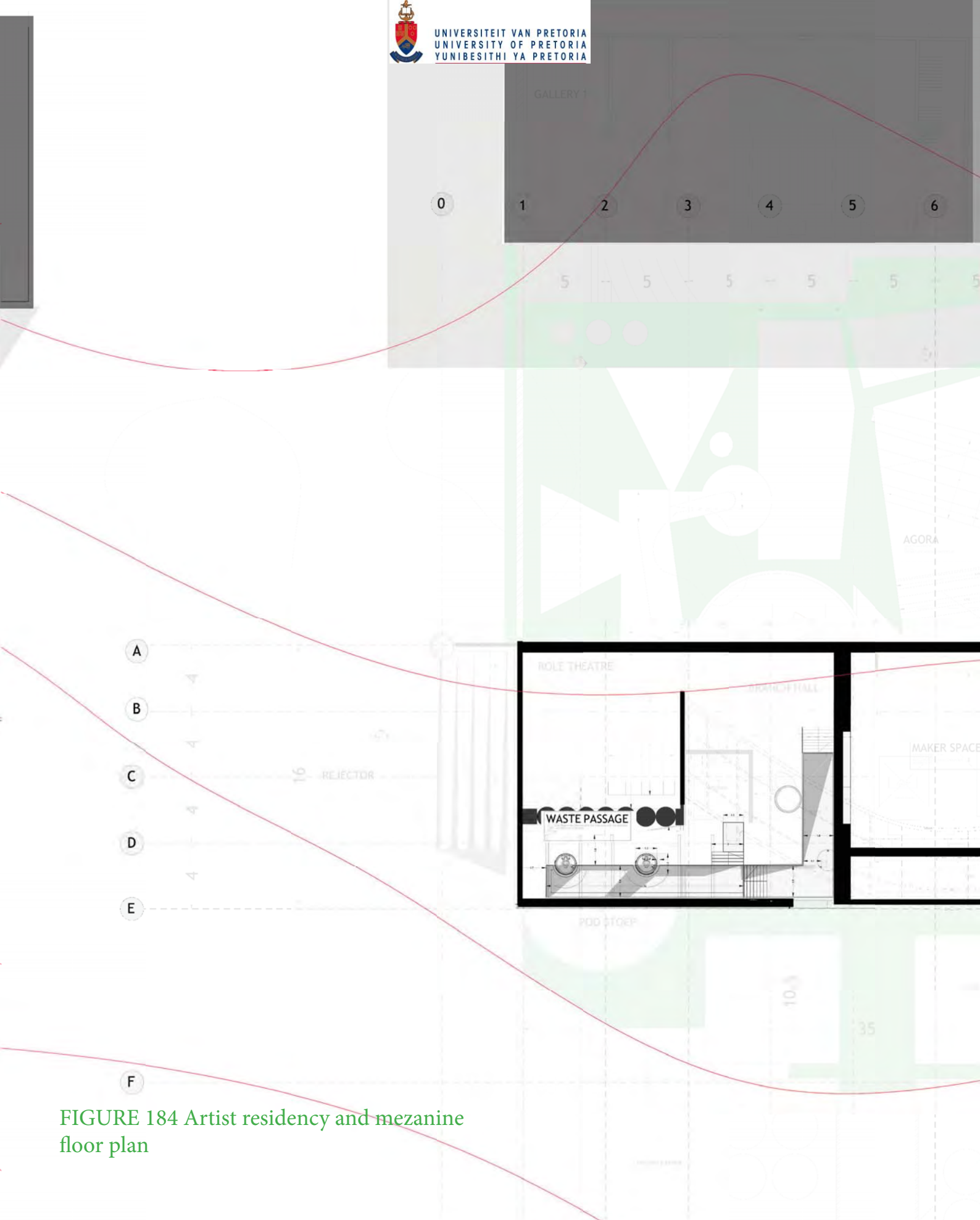

FIGURE 184 Artist residency and mezzanine floor plan



7

8

9

10

5

8

24

26.7

WASTE GARDEN

RESIDENCE

SE COH

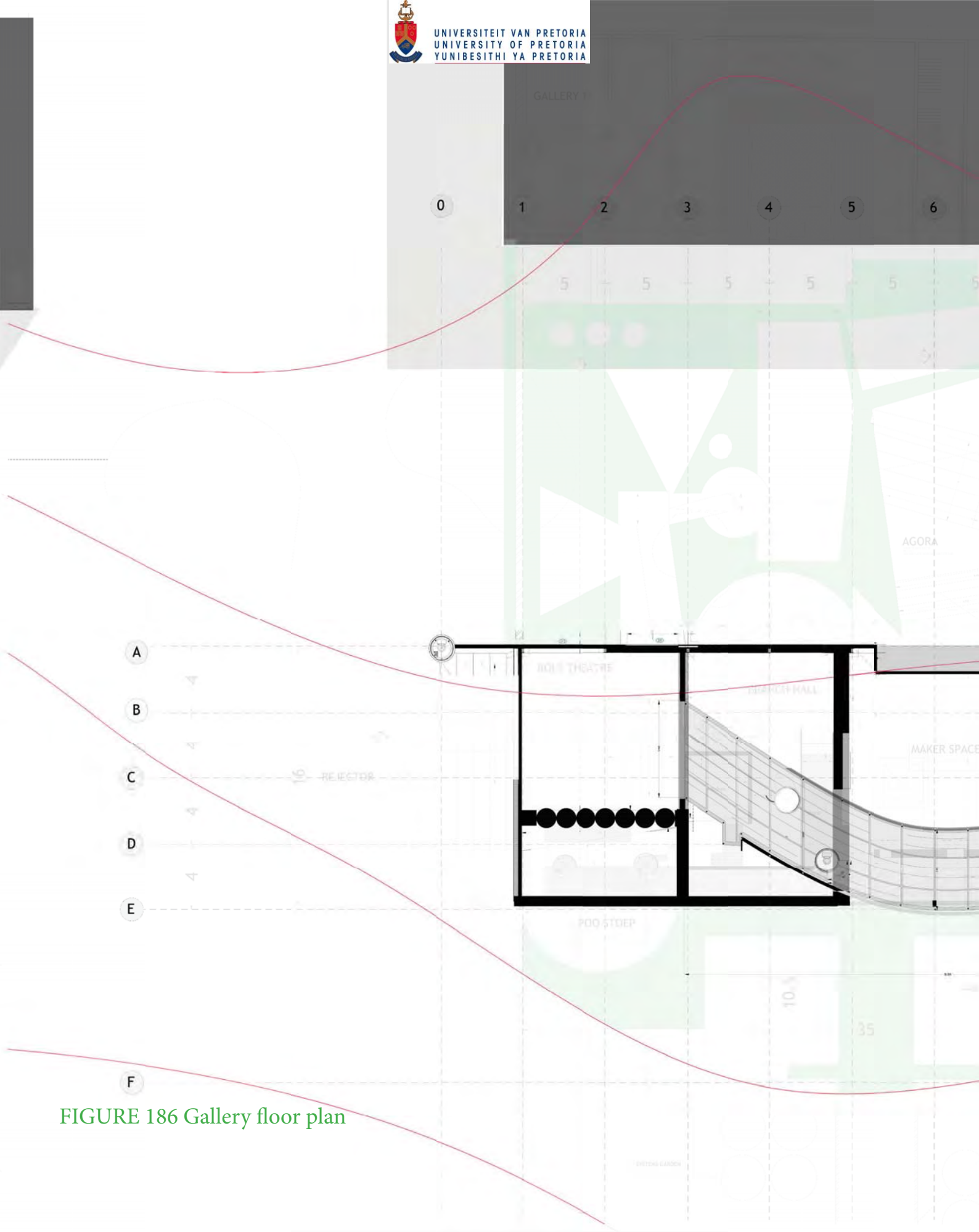

FIGURE 186 Gallery floor plan



7

8

9

10

5

24

26.7

WASTE GARDEN

DEACON





# BEACON ; PLASTIC [NEW]

The structure of the beacon seek to use plastic construction in the same way that they are applied in everyday construction, polycarbonate sheeting and such. The structure seeks to embody the characteristics of plastic of transparency and morphology and experimentalism.

Below is a perspective view of the public entrance, which is essentially the secondary beacon, the artist residency being the first. When referring to the plan it is clear that beacons will use same constructions in different scales in conjunction with surfaces of the

role platform by which to facilitate the movements according to frequency of use etc.

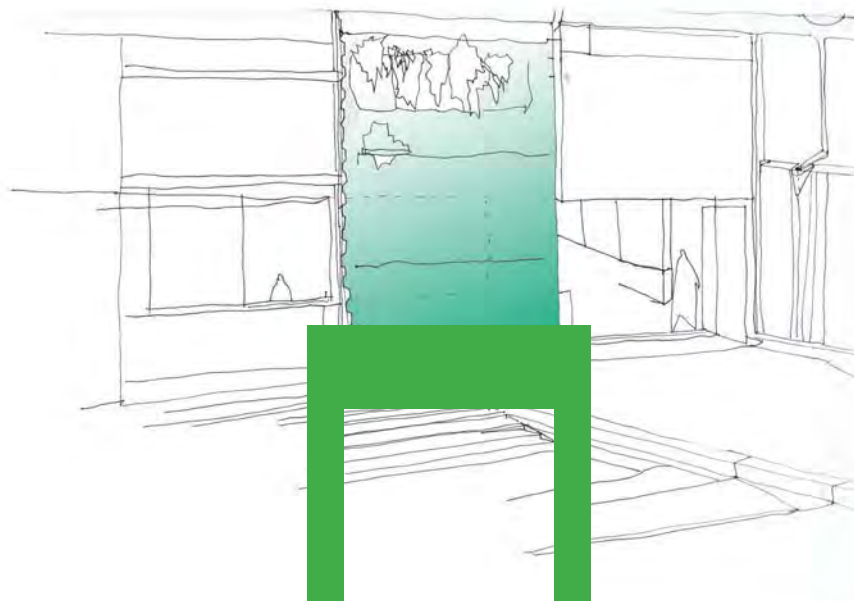
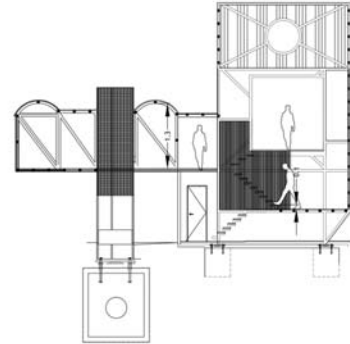
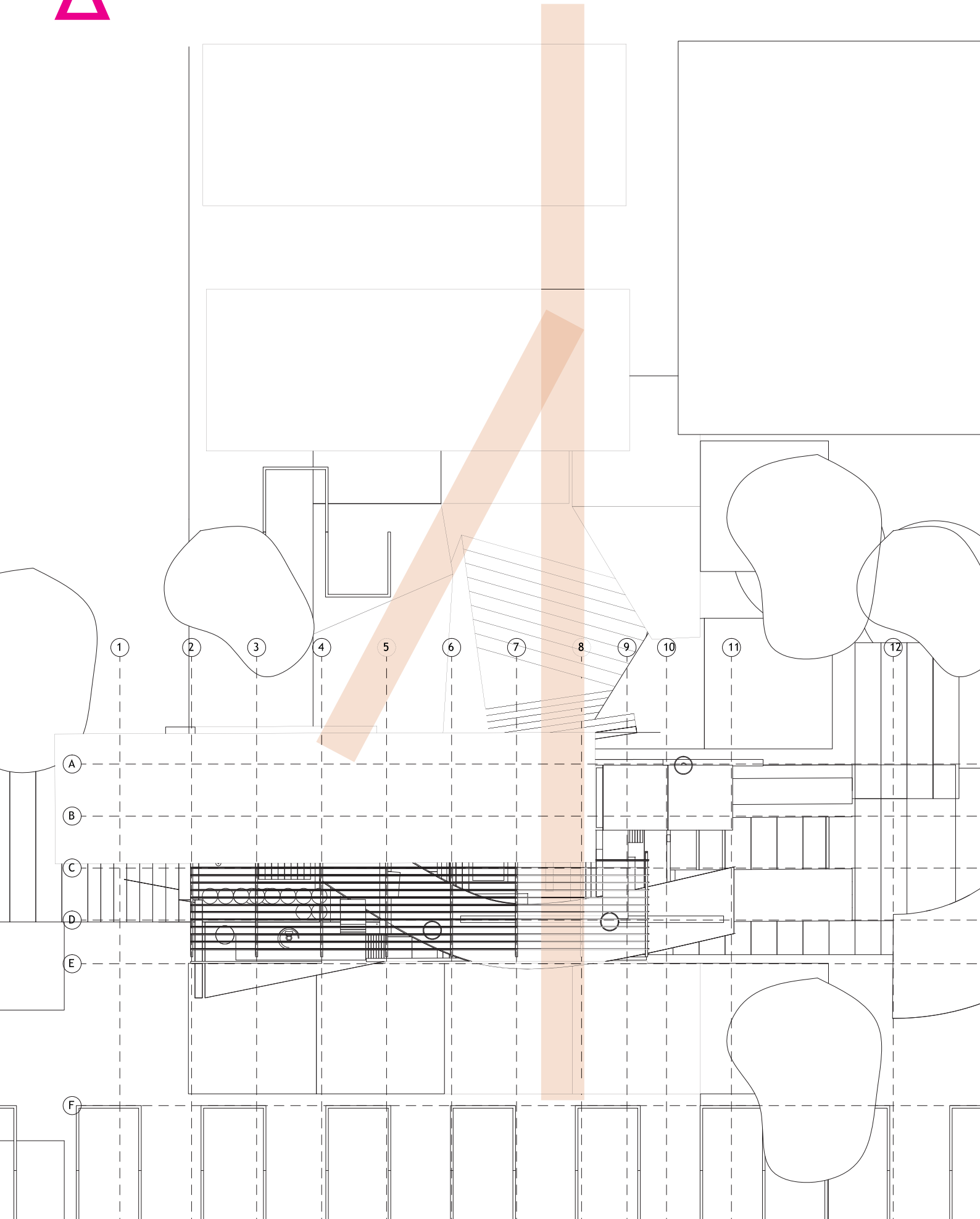

FIGURE 188: Atelier van Lieshout, Clip-On, 1997. Bottom, Jean-Louis Chanéac, Parasite Bedrooms, link to image : <https://s-media-cache-ak0.pinning.com/564x/ab/d1/85/abd1859e4f1ef4ede1e87cf274238836.jpg>



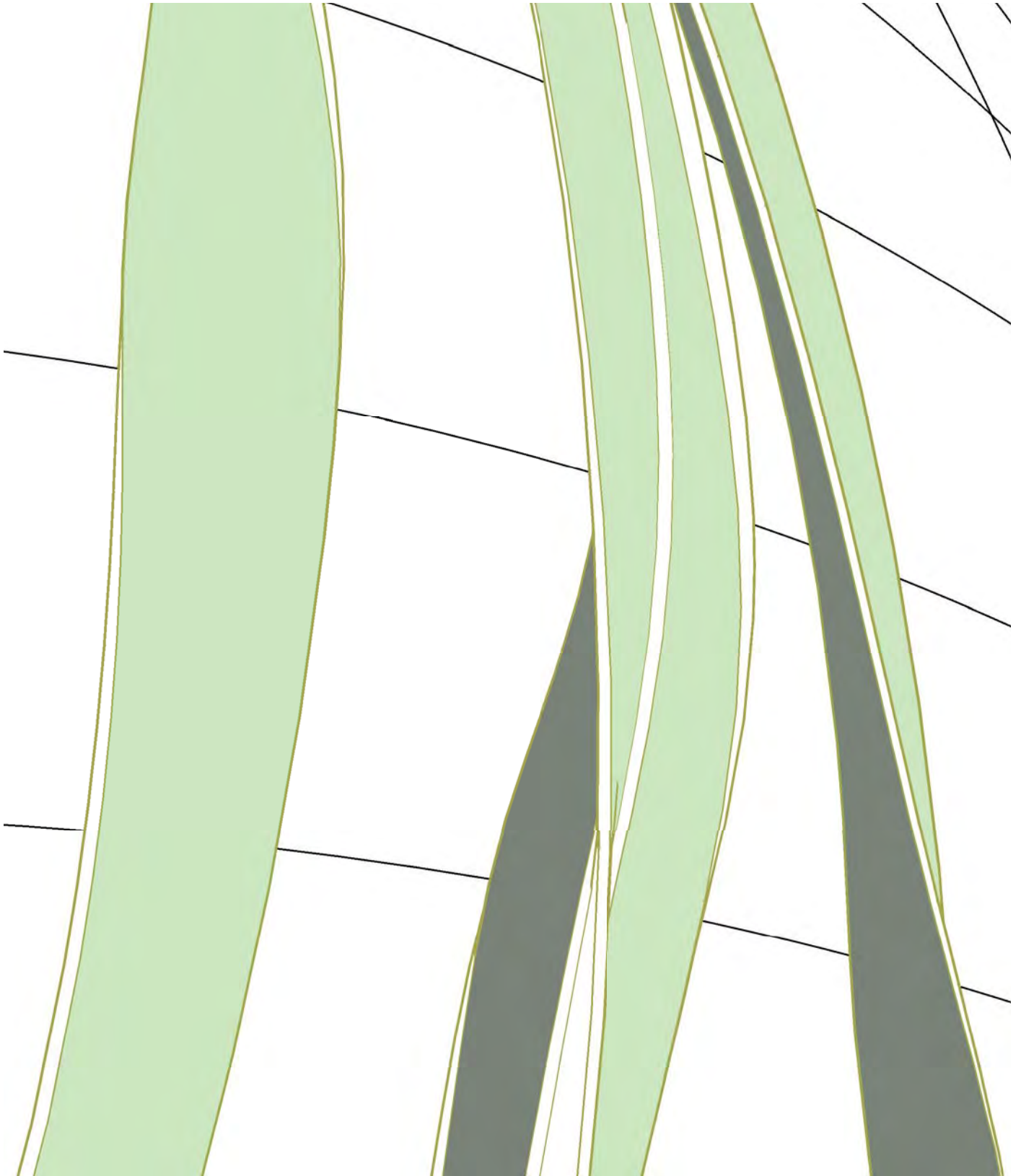
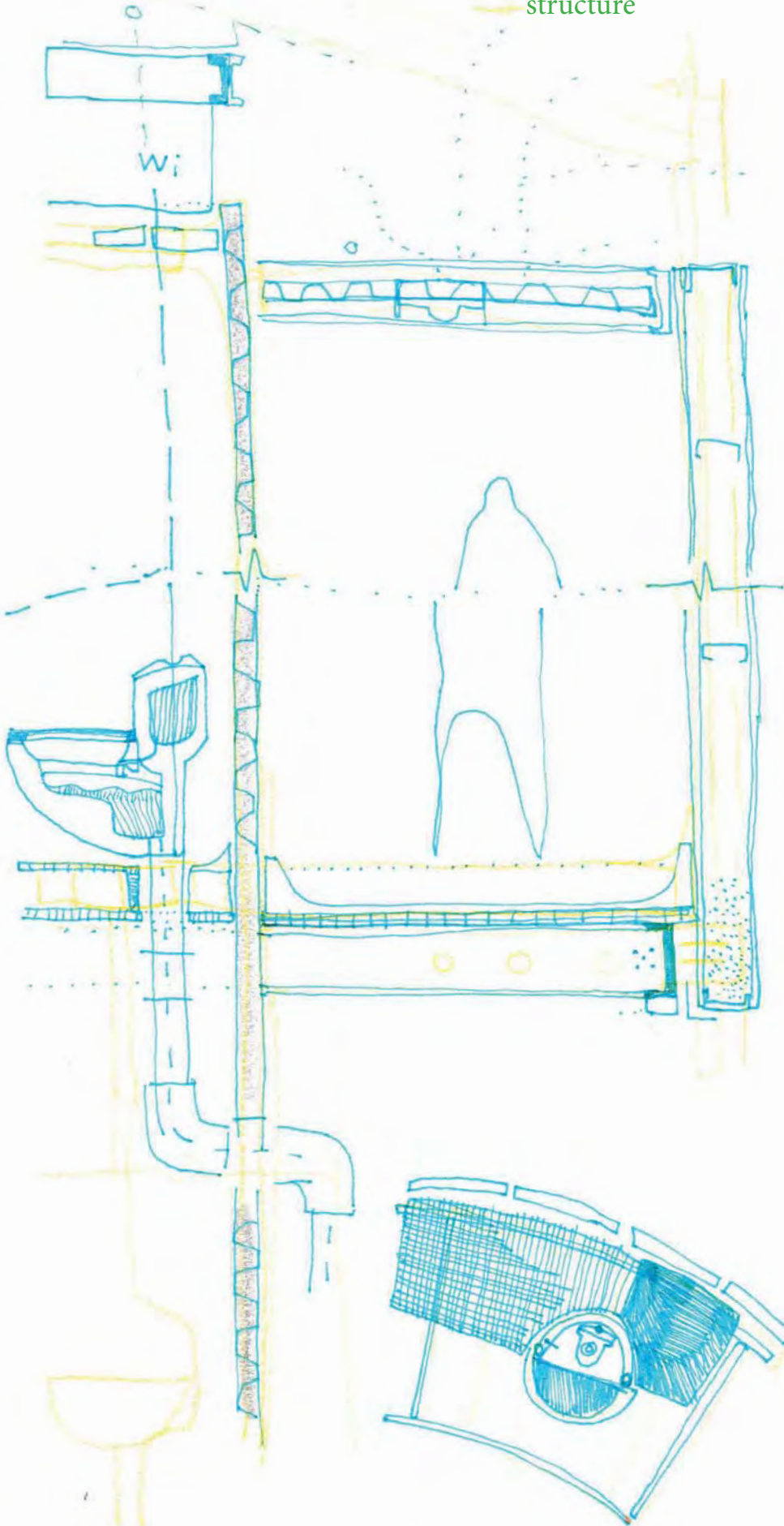

FIGURE 190: Detail modelling of structural elements of steel work for the beacon.



FIGURE 191: Detail section drawing of the piercing toilet structure into gallery floor, as a technical exploration of waste services as structure





# GALLERY : STEEL NEW AND OLD

The gallery is the connecting platform of the building, that allows the user of the space to access not only art works part of exhibitions within the space but also views in the building below and the process of waste processing outside. The gallery is the final insertion into space but is designed in such a per-assembled way that it can be removed and inserted anywhere, elsewhere as a reverse experiment of the method of realising this architecture.

The gallery, as is seen with the symbols above, is the space which incorporates all concepts and this is the

culminating set of details that is generated between an exchange with the gallery and all the other spaces of the building, for example the residency, then the maker space and then the dialogue space. The gallery represents the authors argument of art being the connection between all attitudes and all value systems, and so it embodies all concepts and will live it out through each detail how art accepts, rejects and reflects using the materials of steel as the primary link to the industrial typology.



SOUTH

FIGURE 192 Perspective of the southern facade where the gallery pierces through the face of the existing portal frame and also allows for a social spatial development relating specifically to waste. Opposite pages are steel details [incorrect not updated] and steel modelling of gallery floor and roof components with steel rectangular channels, where circle cut throughs are the service columns.

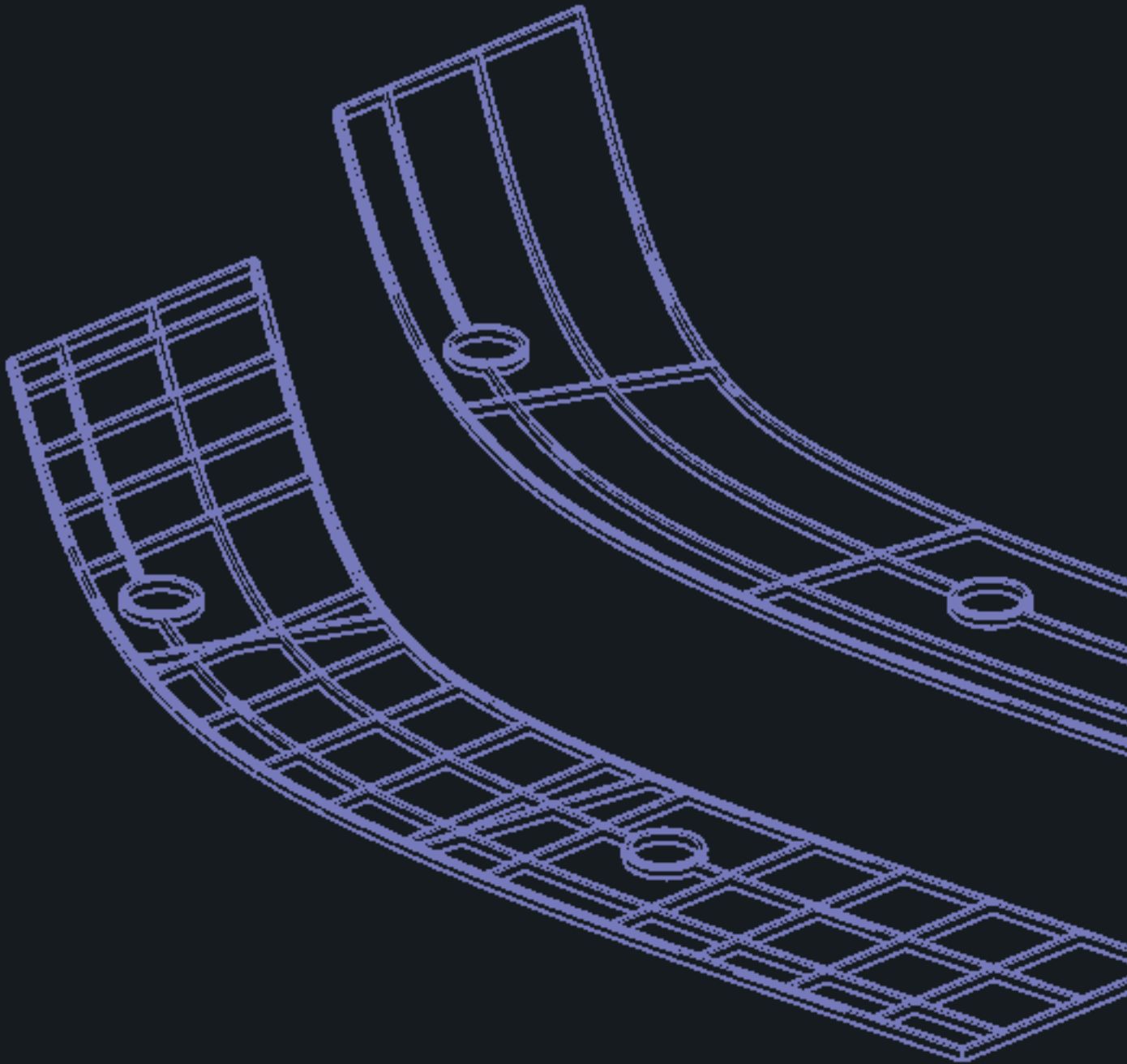
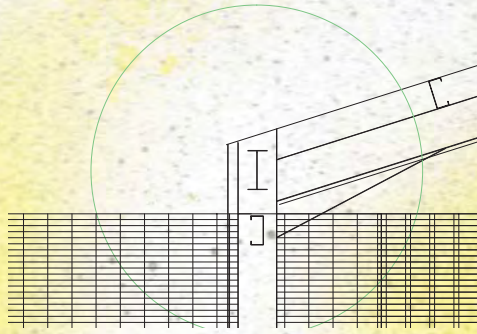



# WASTE FLOOR: WOOD AND TYRES

The construction of the floor elements of the role theatre, specifically those of the maker spaces are related to the spatial requirements and finish requirements of the AAC residency guidelines.

theatre concepts, does so through the enclosure construction itself- using tyre walls like that of rural studios tyre chapel.

The surface will seek to utilise the positive aspects of plastics in recycled manners as a type of image of potential and will then make use of brickwork construction to enclose it. The plastic foundational quality will not be continued in the dialogue space, which despite also functioning as a space for role

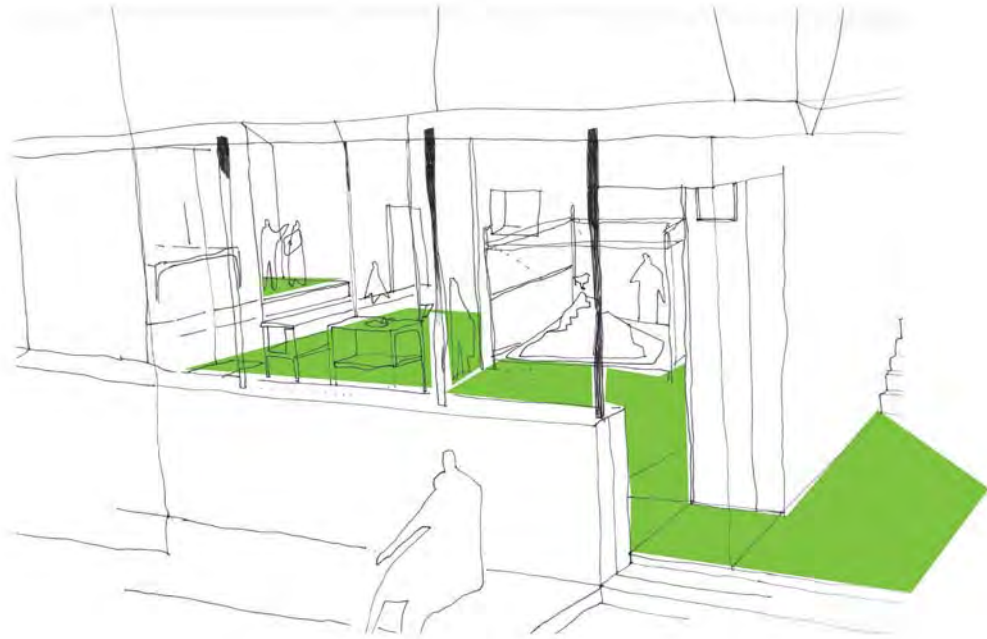

FIGURE 194 Perspective view into the maker space, connection onto elevation with the outdoor role theatre space. 168B Image of Ubuntu blocks as reference to plastic potential as flooring enclosing material.

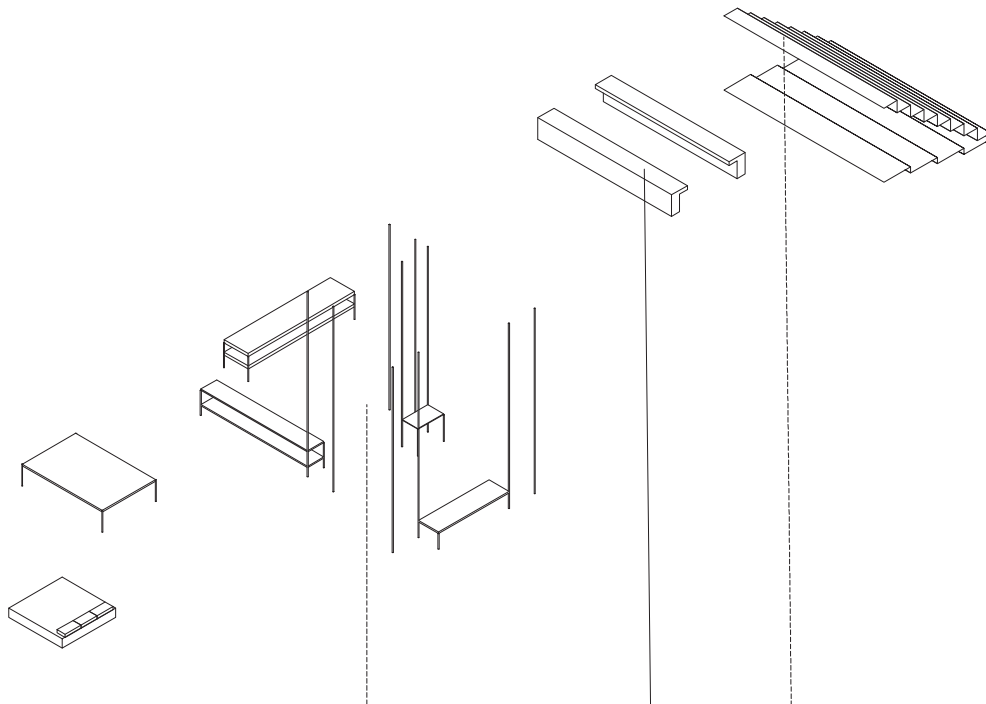
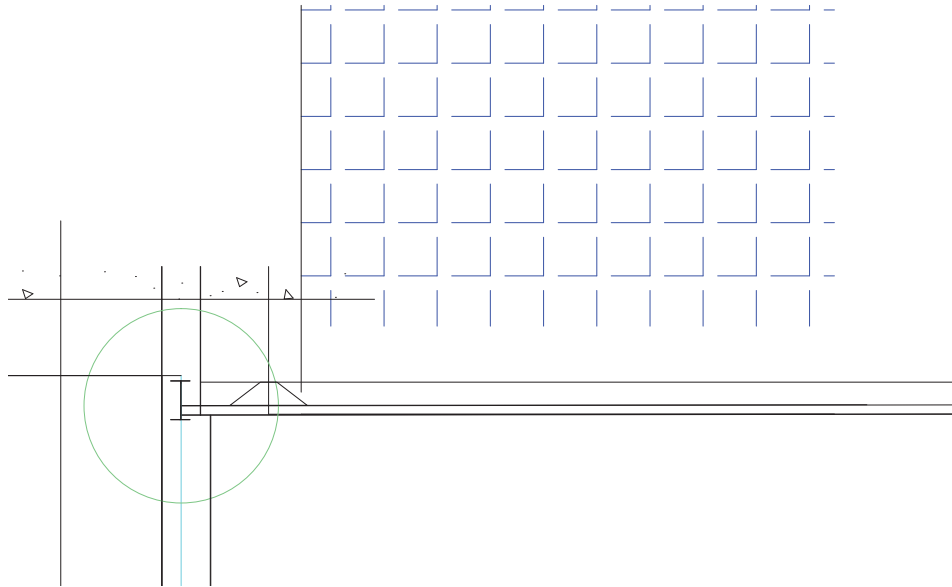

FIGURE 195 Progress detail of elevation forms and structure that accepts, rejects and reflects on energy and waste and a 3d exploded perspective of how work spaces and their surfaces plug into the structure again as part of the the role theatres expression of enclosure according to program.





# DOOR : ~ MOVING COLUMNS

The doorway is the element of the building which could essentially be described as the moving wall. The door is that which permeates and encloses and defines spaces as well as breaking it open.

The building consists of several of these doors, which seek to borrow from both the suburban and the industrial typologies of Silverton.

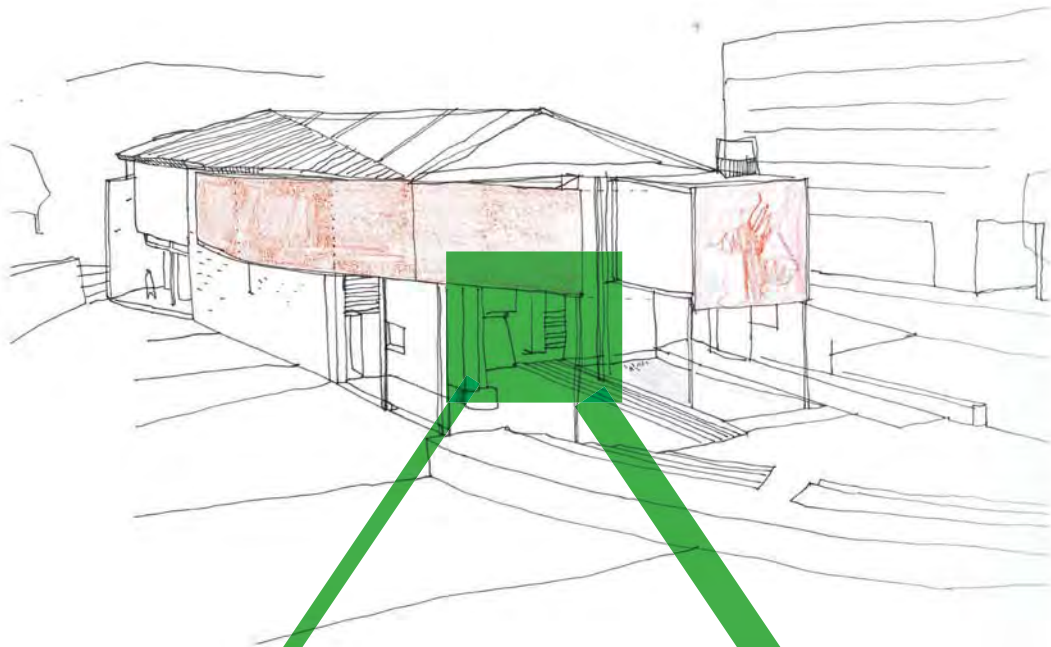
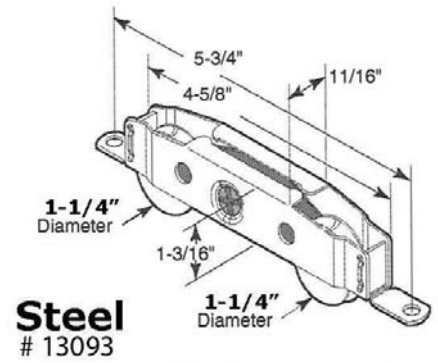
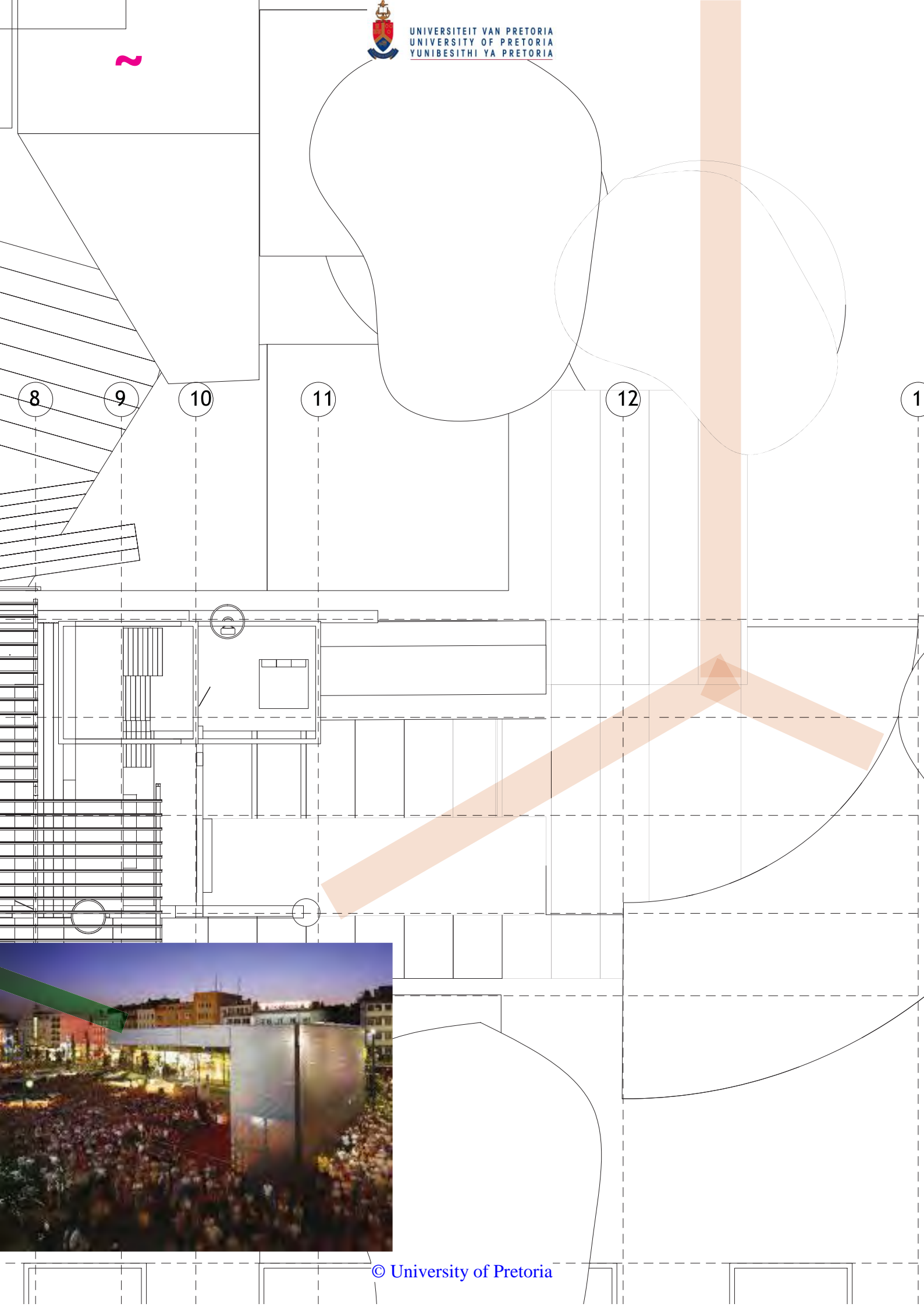

FIGURE 196 Perspective of the eastern entrance for waste delivery. Images making reference to the suburban garage door, to the right a plan displaying movement of waste from waste entry and finally a precedent of movement with the SpielbudenPlatz project by NL Architects/  
<http://www.gkdmetailfabrics.com/files/news/big/da7ab74cb3a1a7163fd98d2f9223b228.gif>



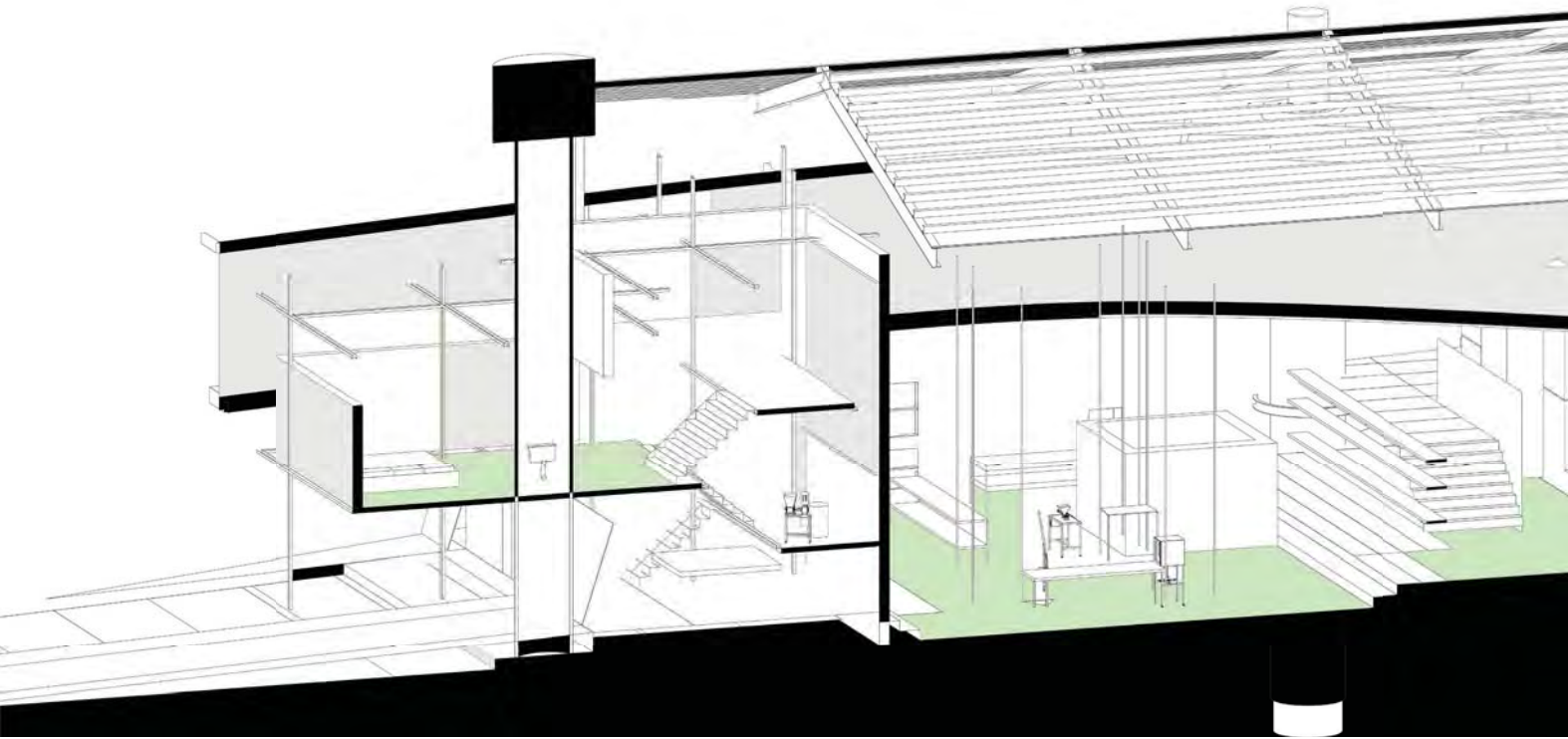
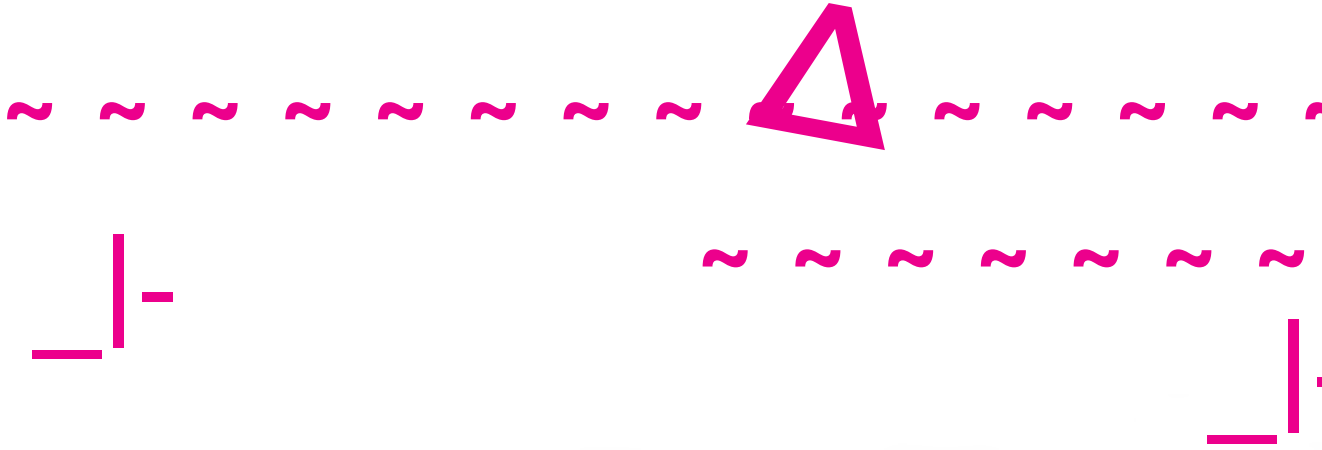
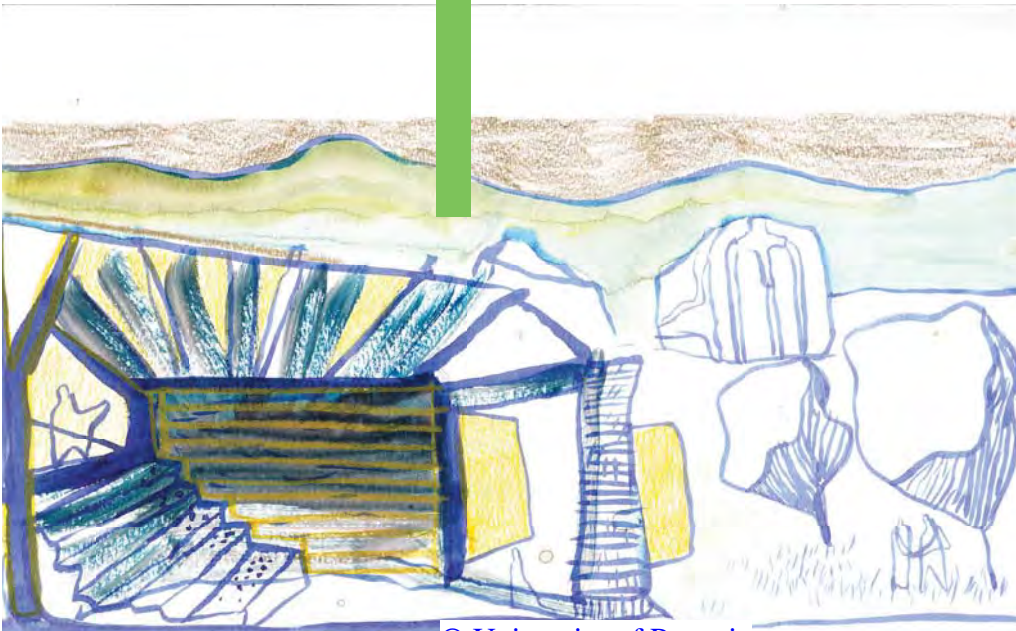
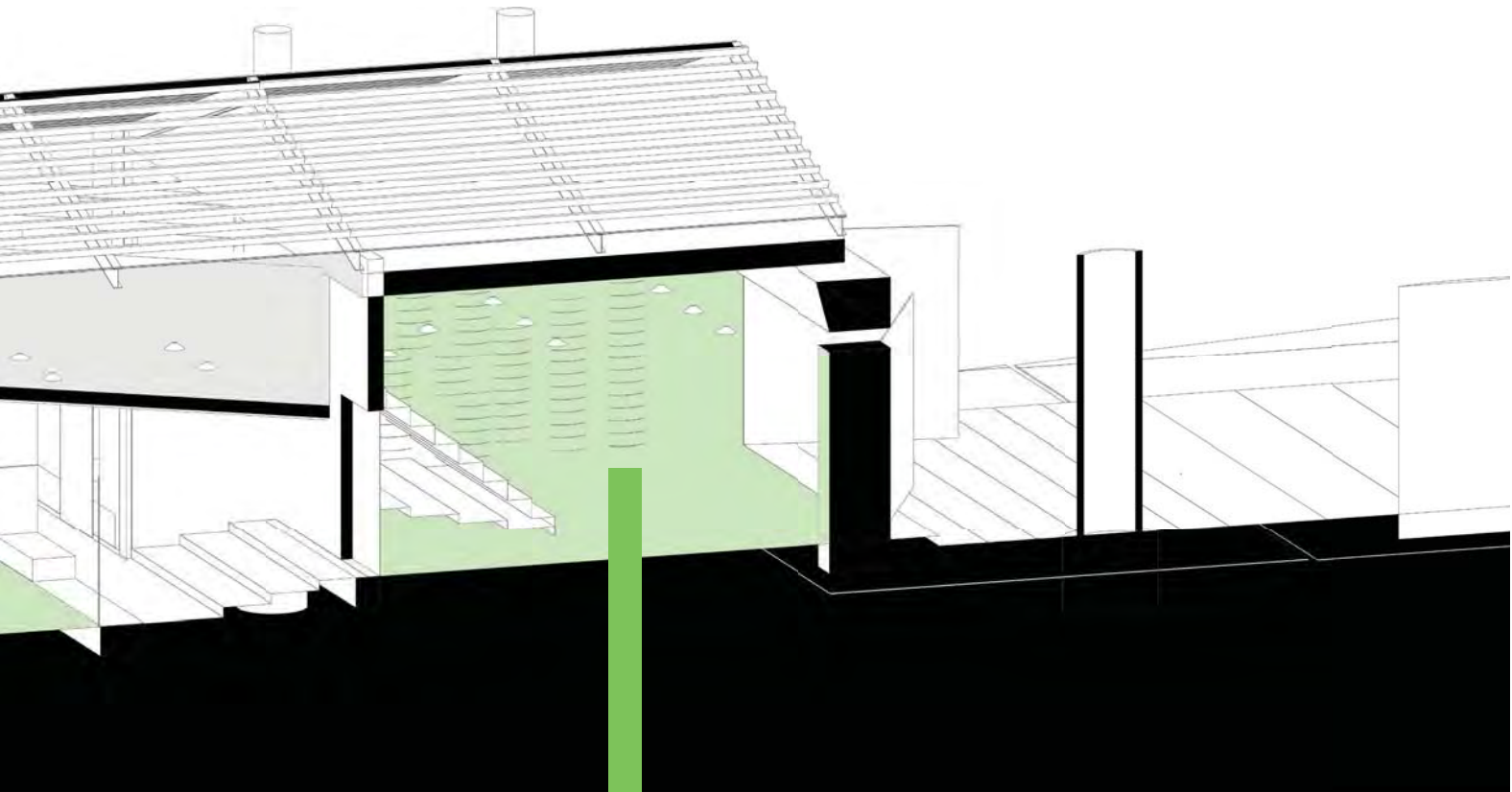

FIGURE 198: 3d perimeter section of the building with its legends and connected sketch of a 3d perspective of the role theatre on the right bottom.



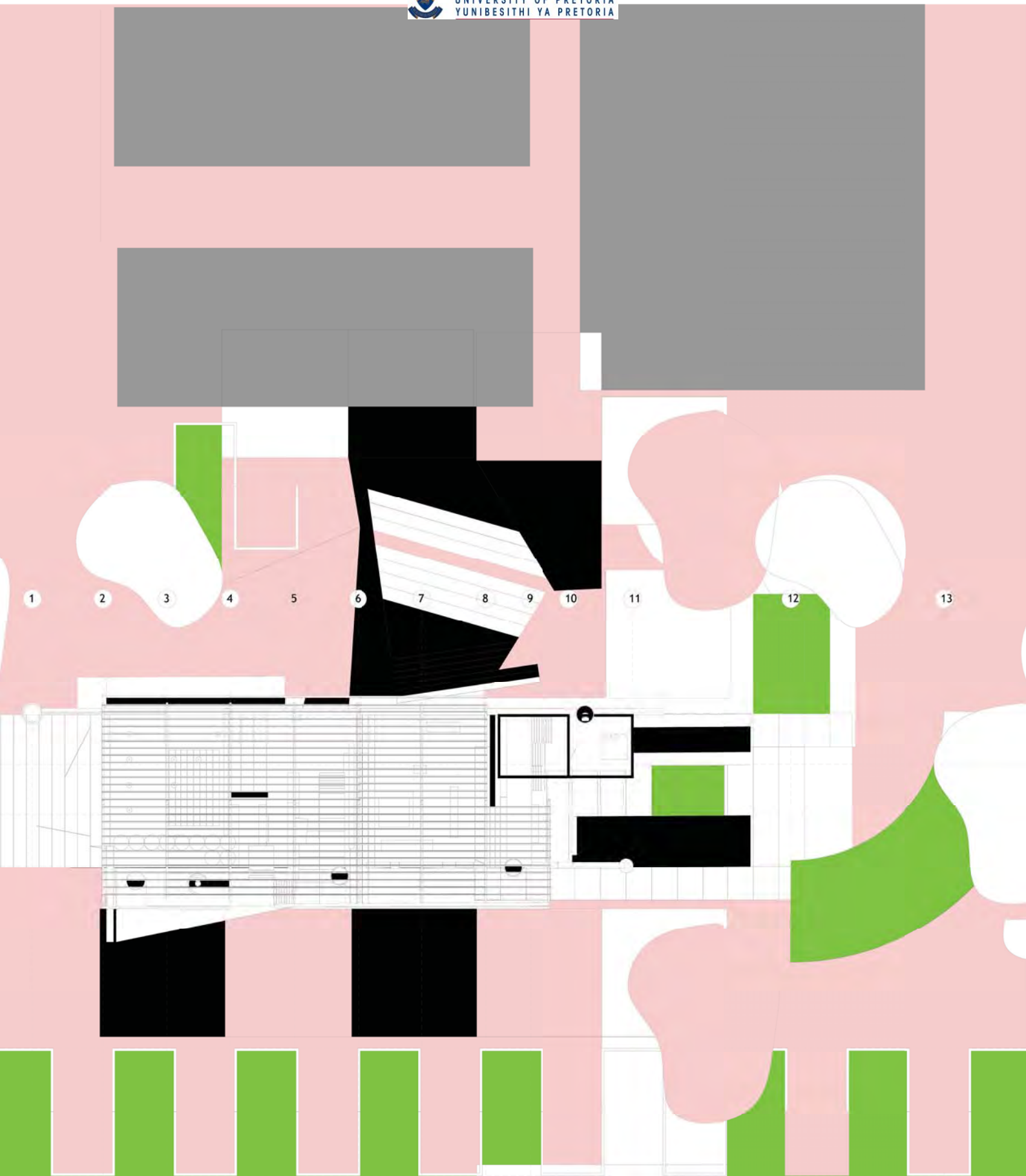
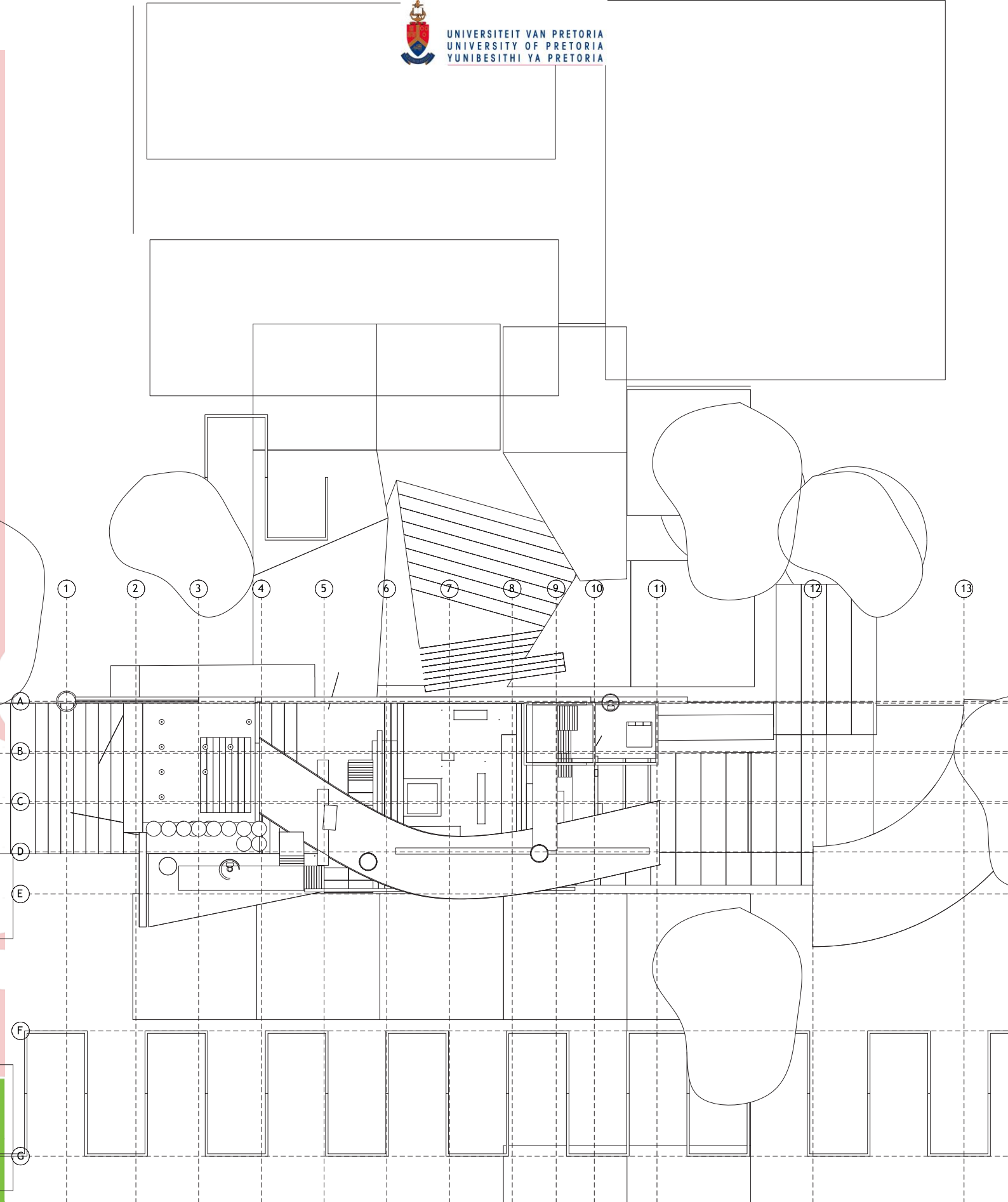

FIGURE 200 Plans of site and plans of the top floor of hte building, in progress.



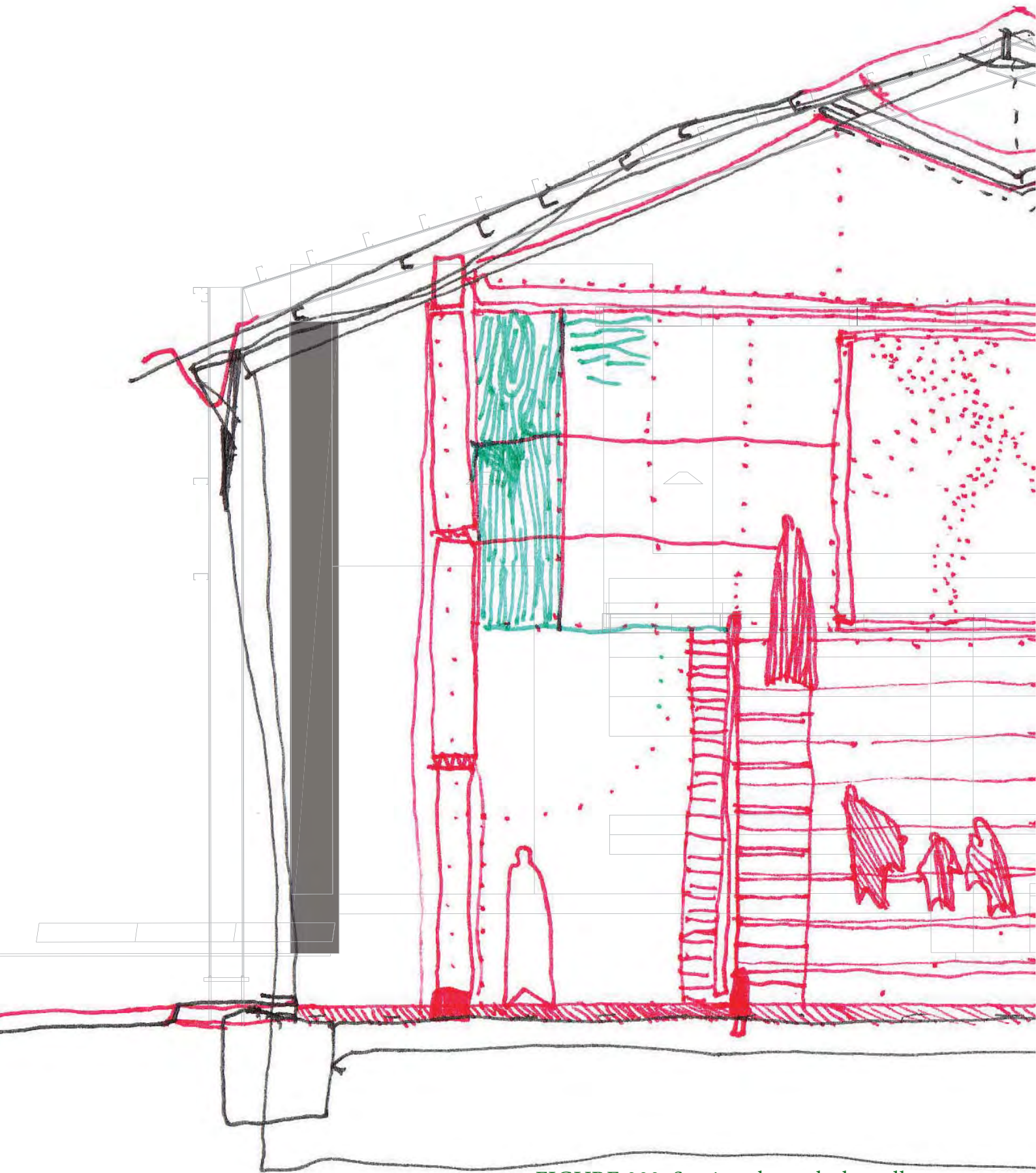
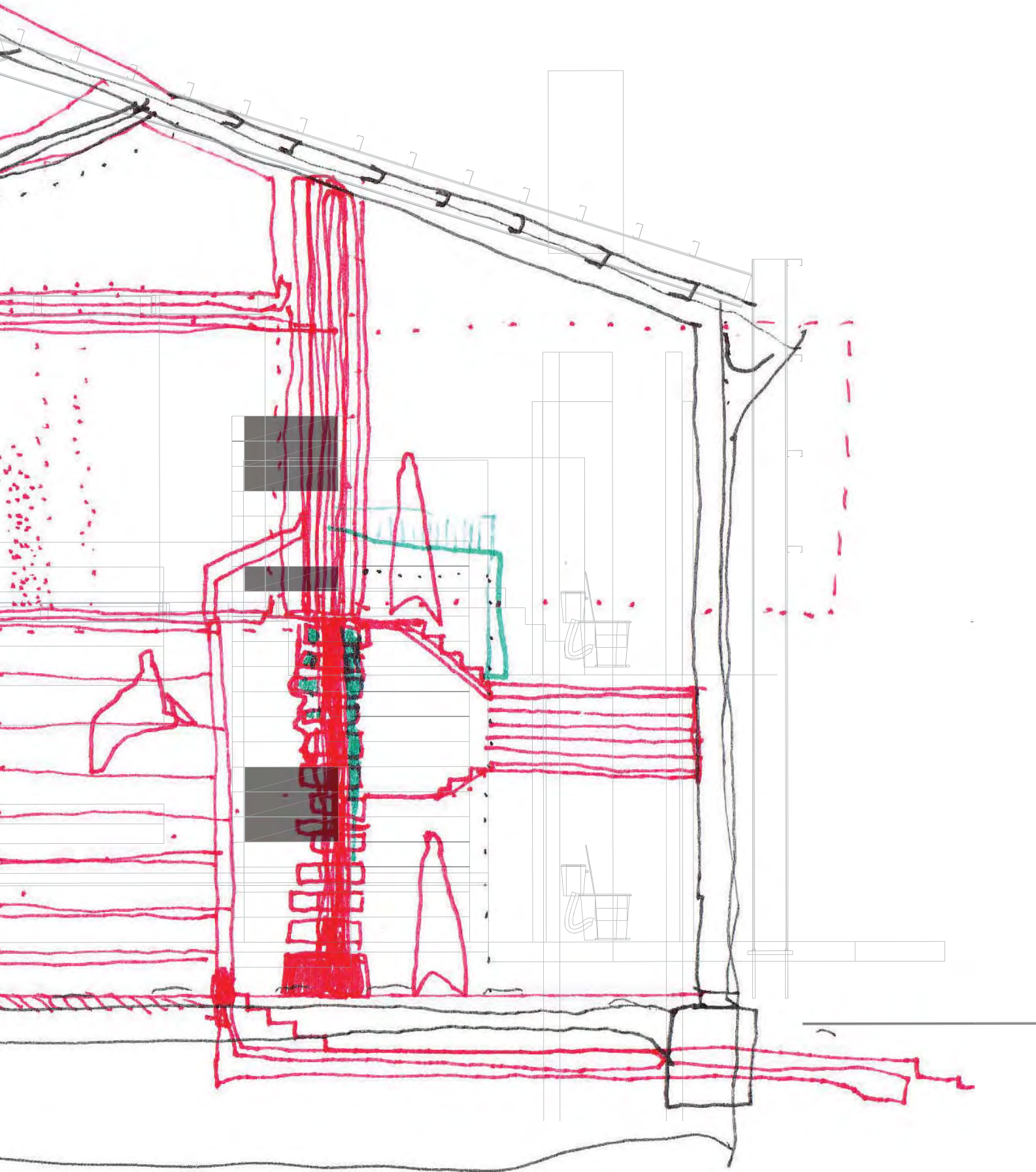

FIGURE 202: Section through the gallery and the role theatre space with tire wall construction and spolia brick.





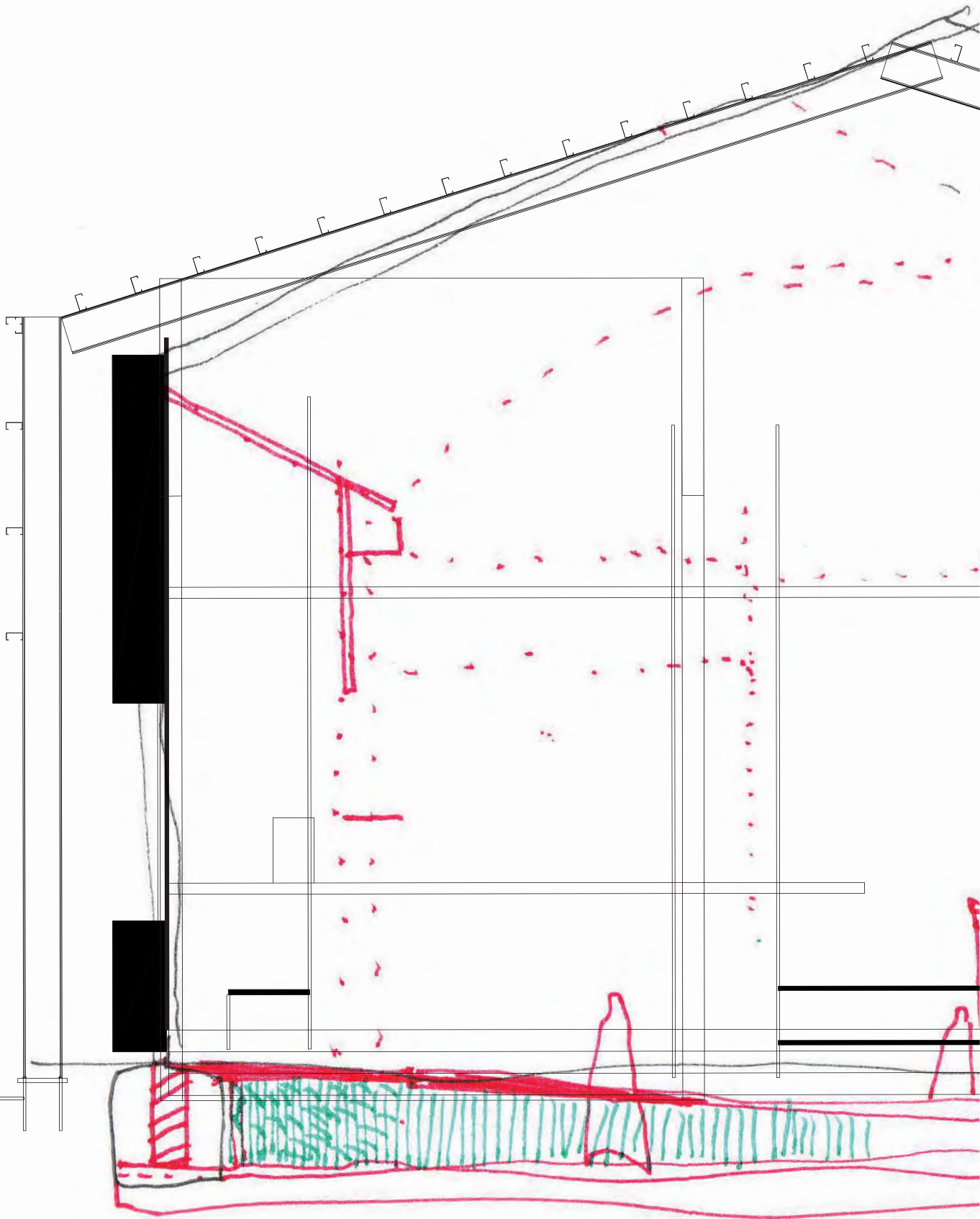
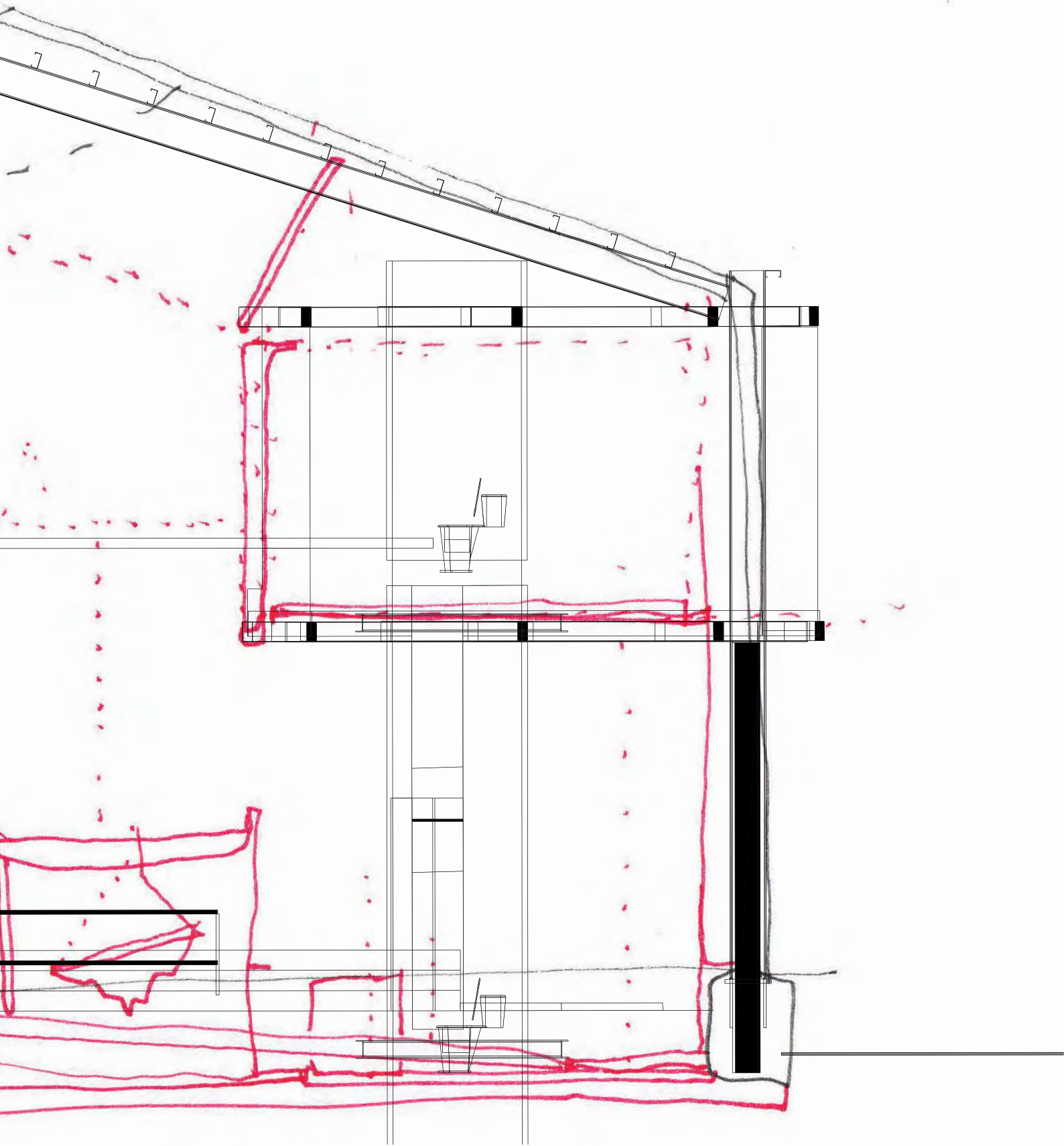

FIGURE 204 : Section through maker space and gallery with the beacon in the distance. and 3d printer on maker space floor.



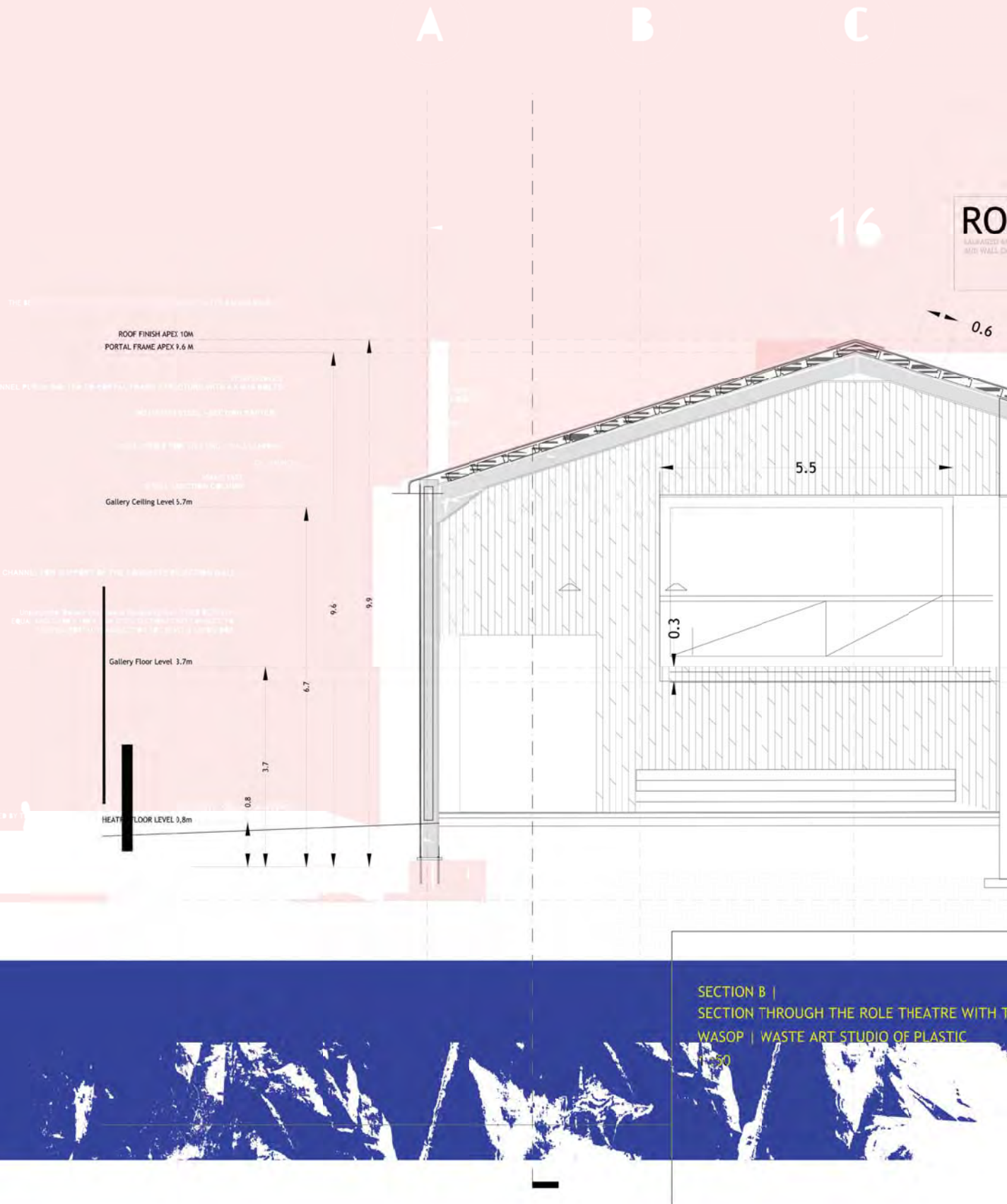

FIGURE 206 Section B with role theatre space cut through and toilet /plastic column



# D E

## LE THEATRE

RECYCLED WOOD CLADDING ONTO CONCRETE FLOOR  
TO WHICH THE GALLERY TYP WILL THEN REST

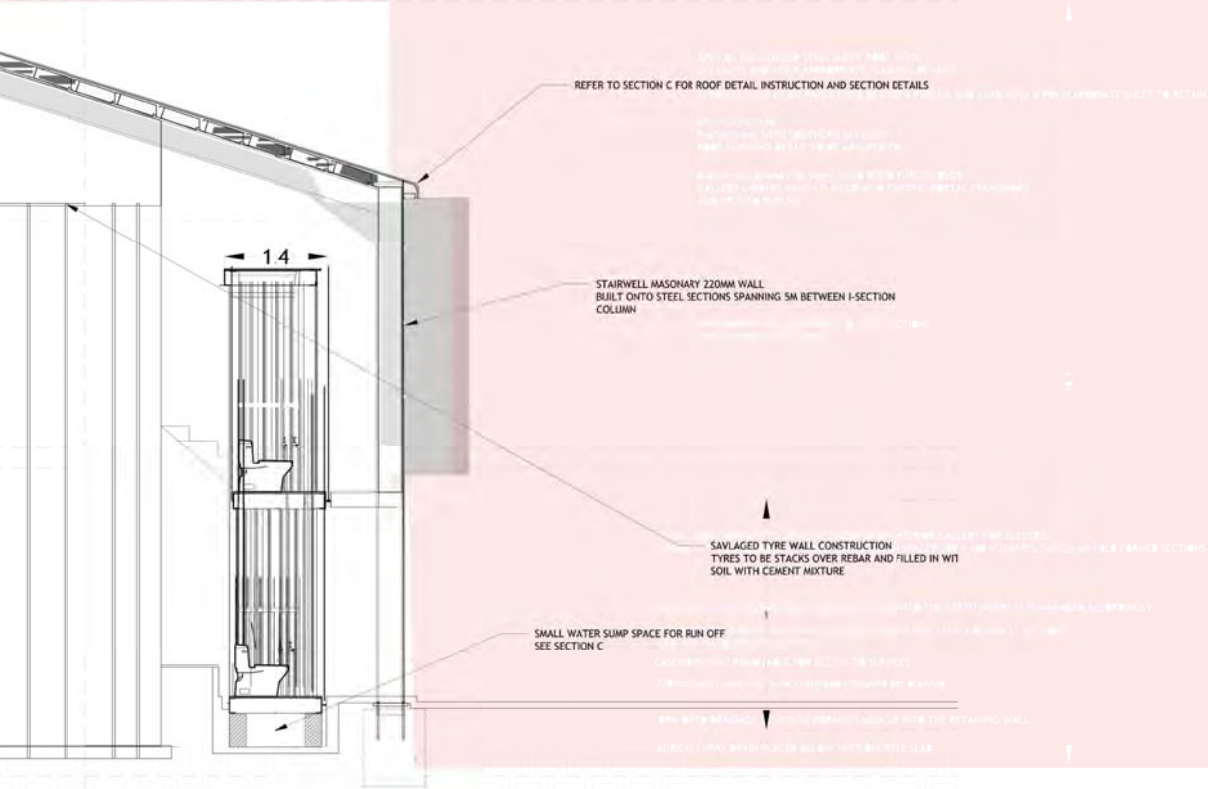

THE FREQUENCY GALLERY IN EACH



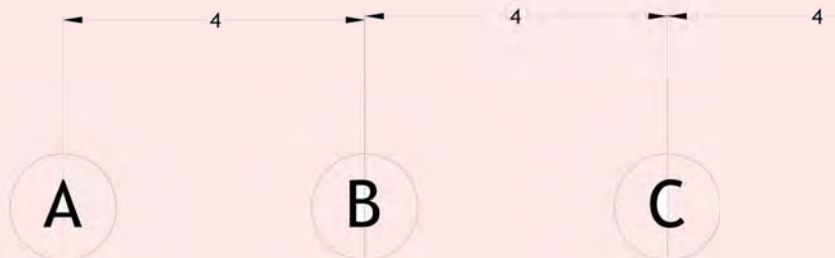

16

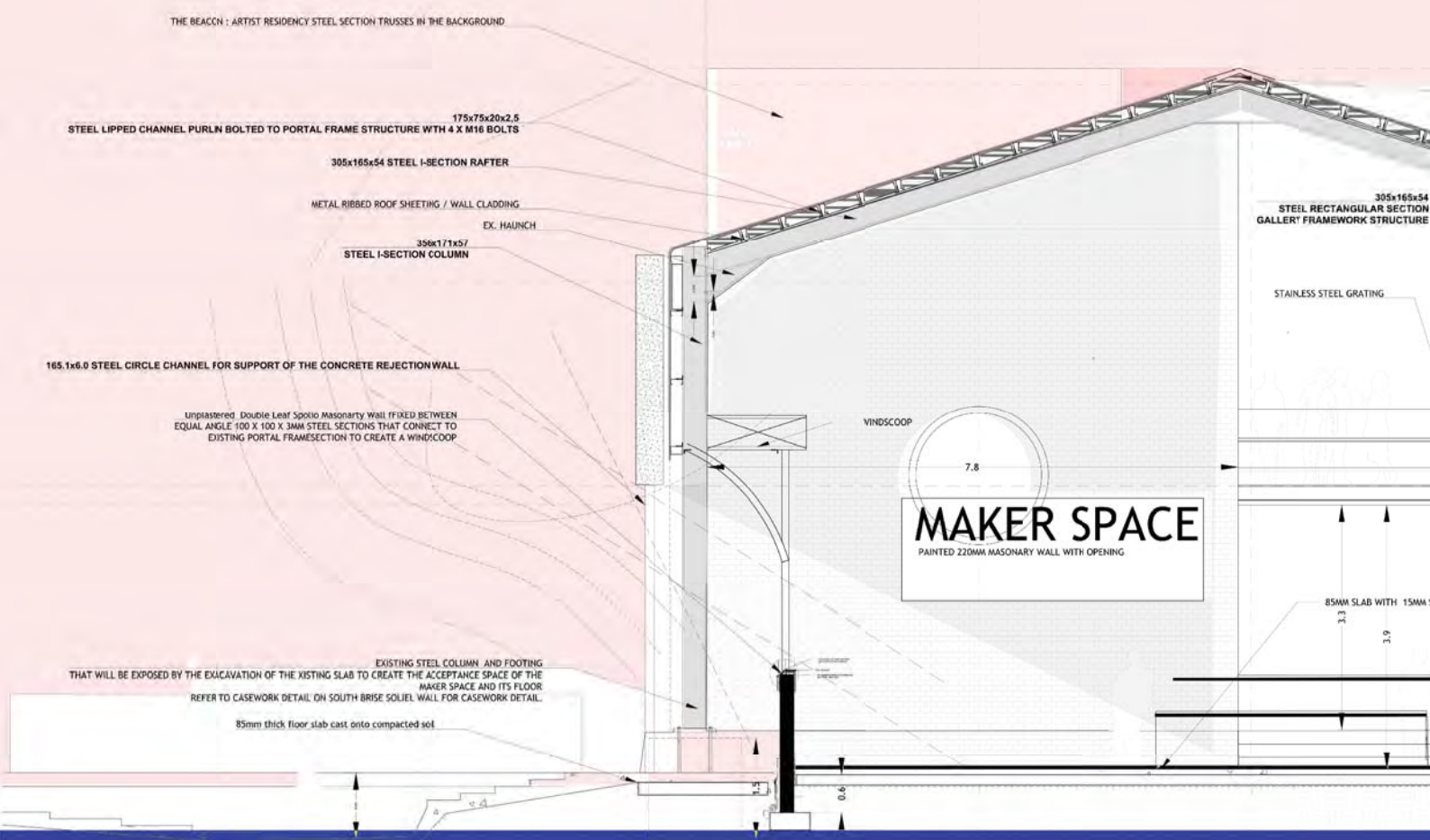

1:4

FIGURE 208 Section C of maker space with residency in the background

SECTION C | SECTION OF MAKER SPACE WITH RESIDENCY  
WASOP  
1 : 50



4

D

E

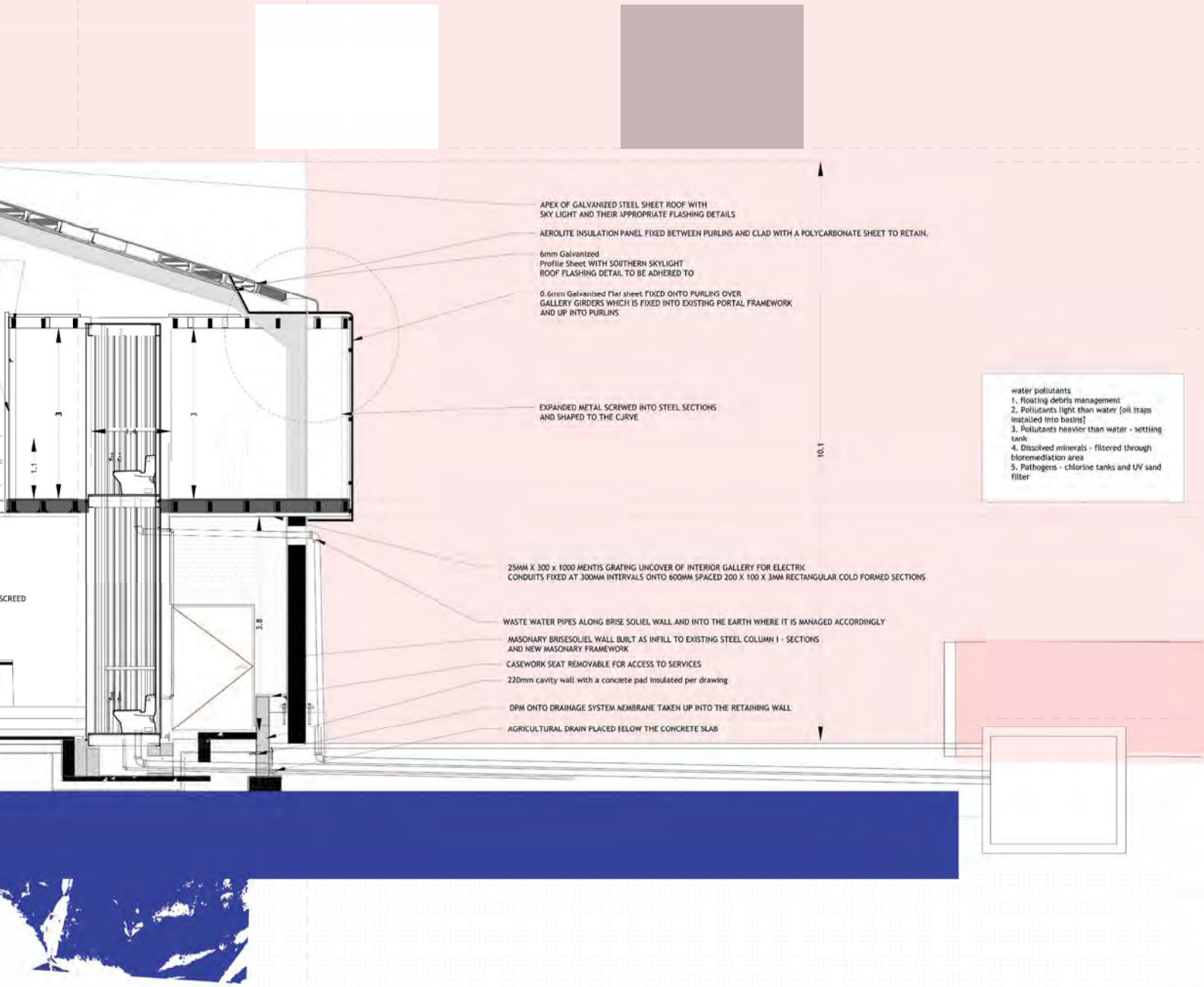

ENCY IN BACKGROUND AND GALLERY TO THE RIGHT

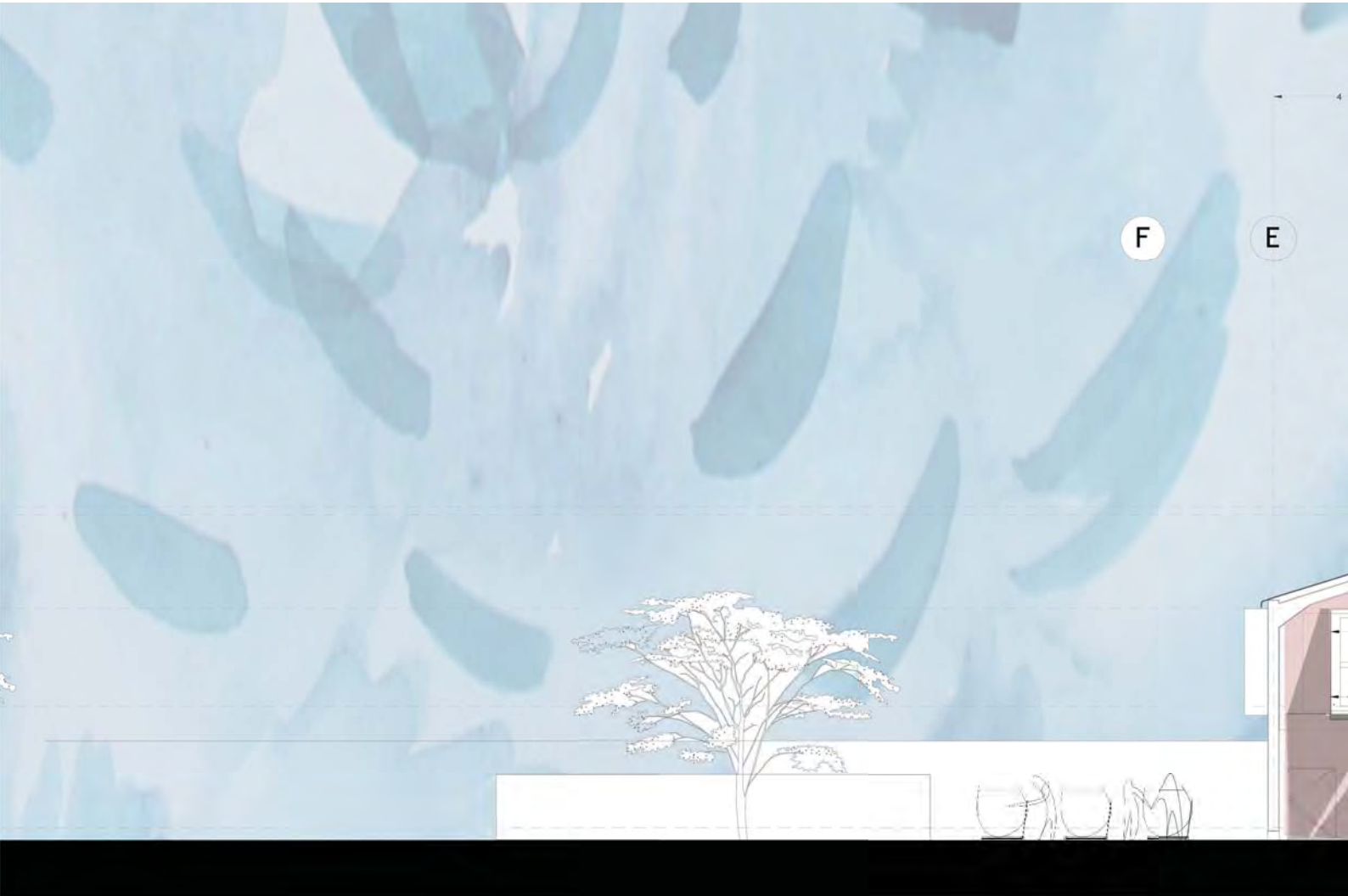

e

ACCEPTOR | EASTERN ELEVATION  
1:100

FIGURE 210 Eastern elevation

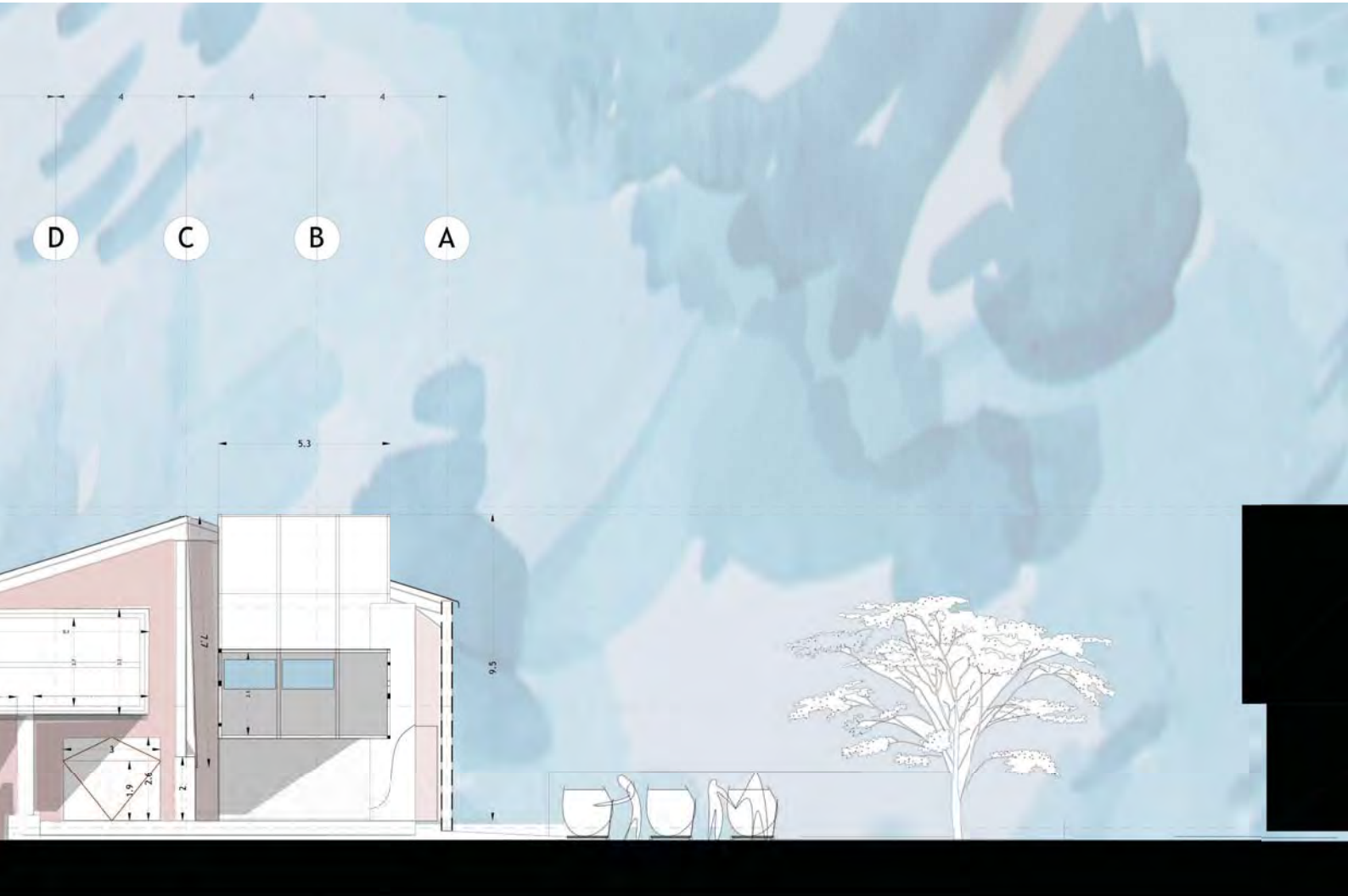

## SECTION OF RESIDENCY AND GALLERY ENDS



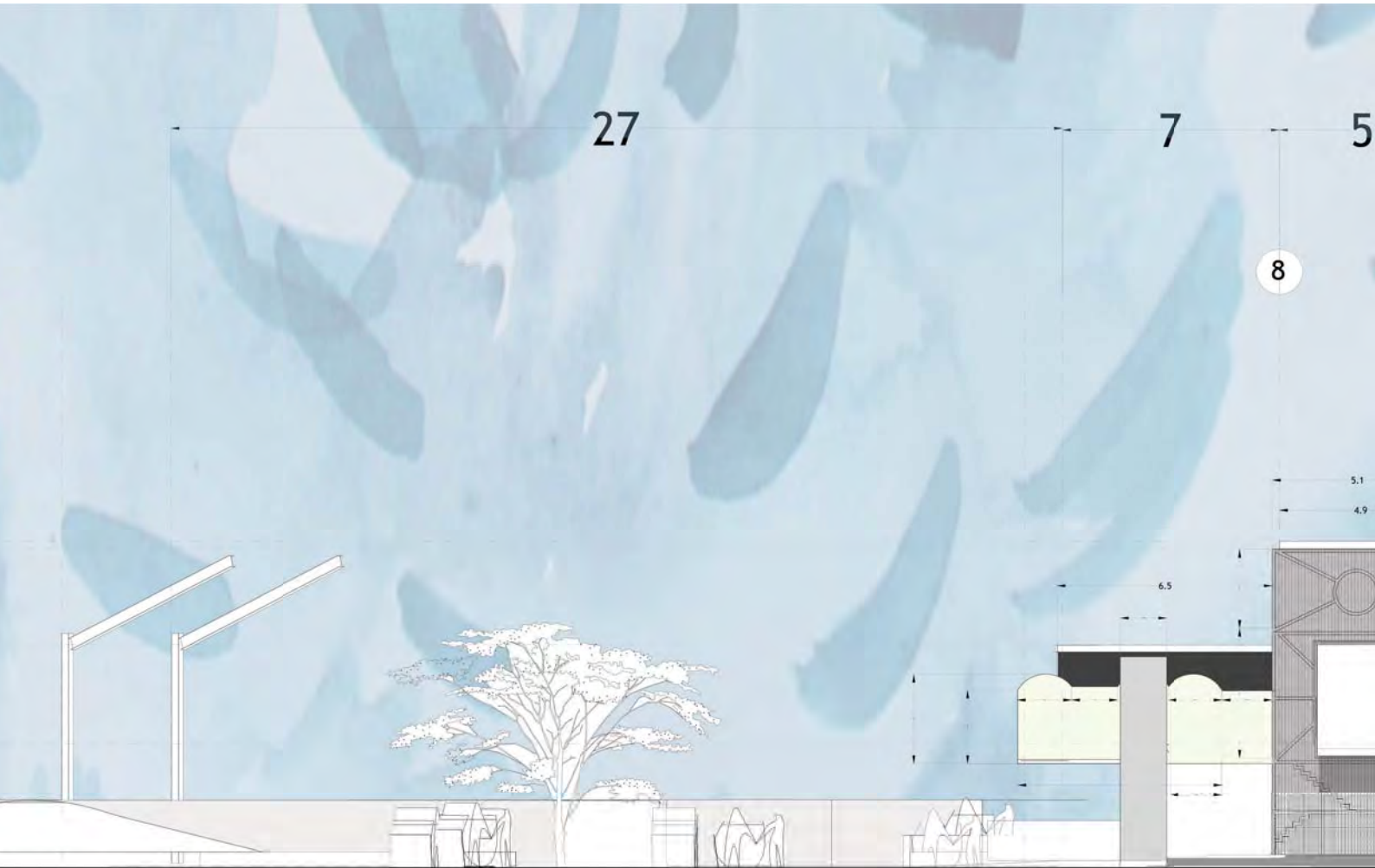

n

REFLECTOR | NORTHERN ELEVATION  
1:100

FIGURE 212 Northern elevation

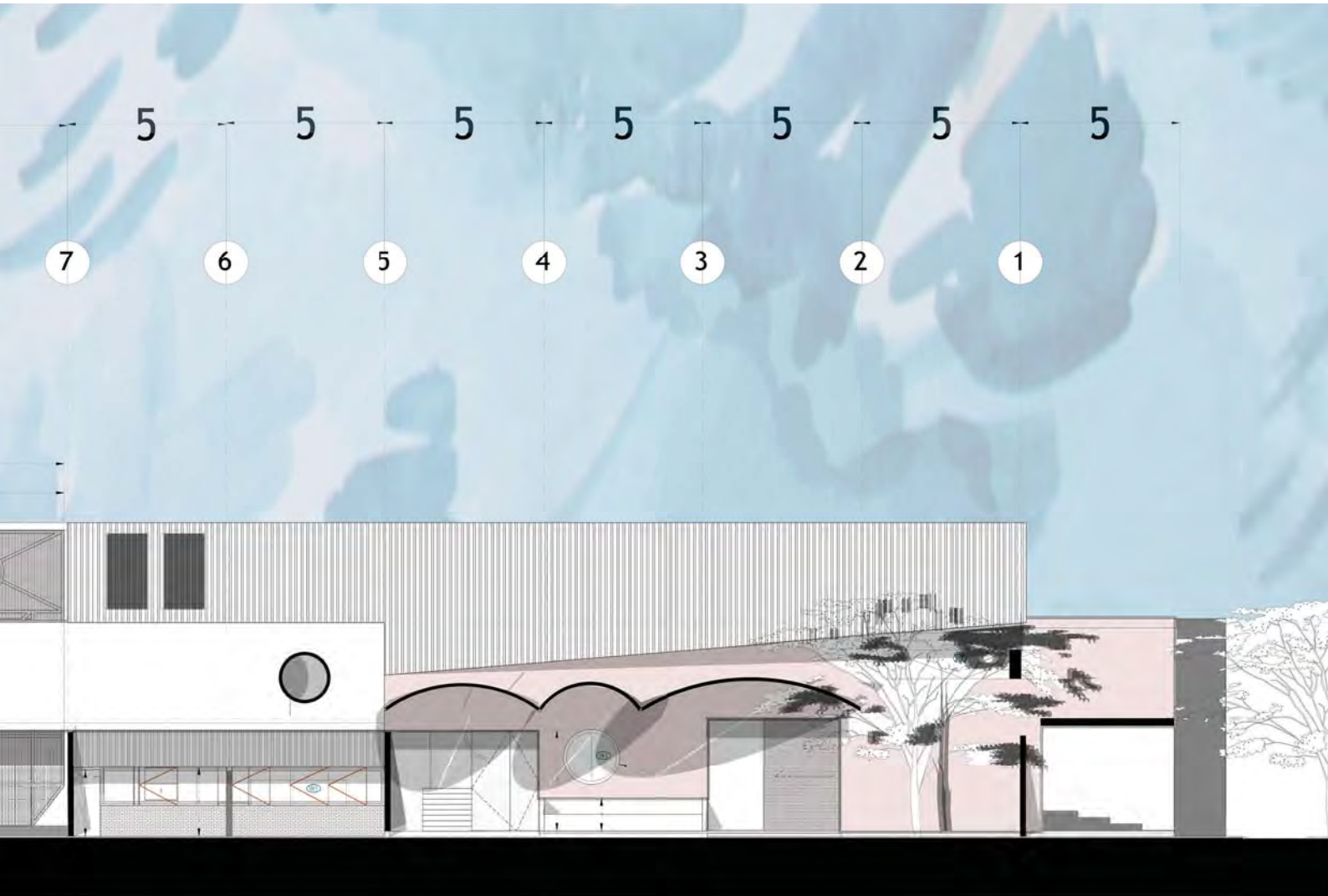

## ELEVATION OF BEACON

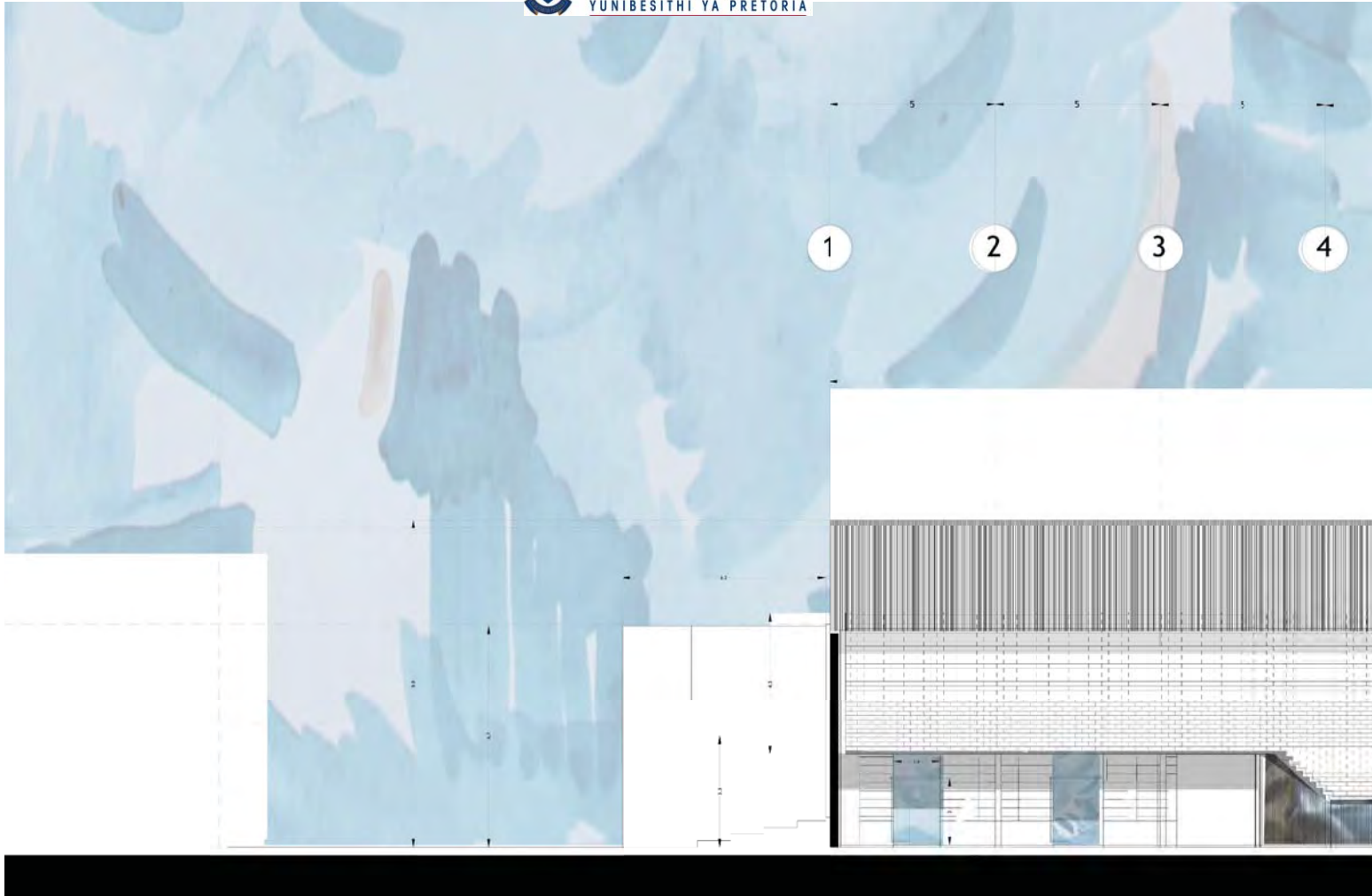

W

REFLECTOR | SOUTHERN ELEVATION  
1:100

FIGURE 214 Southern Elevation

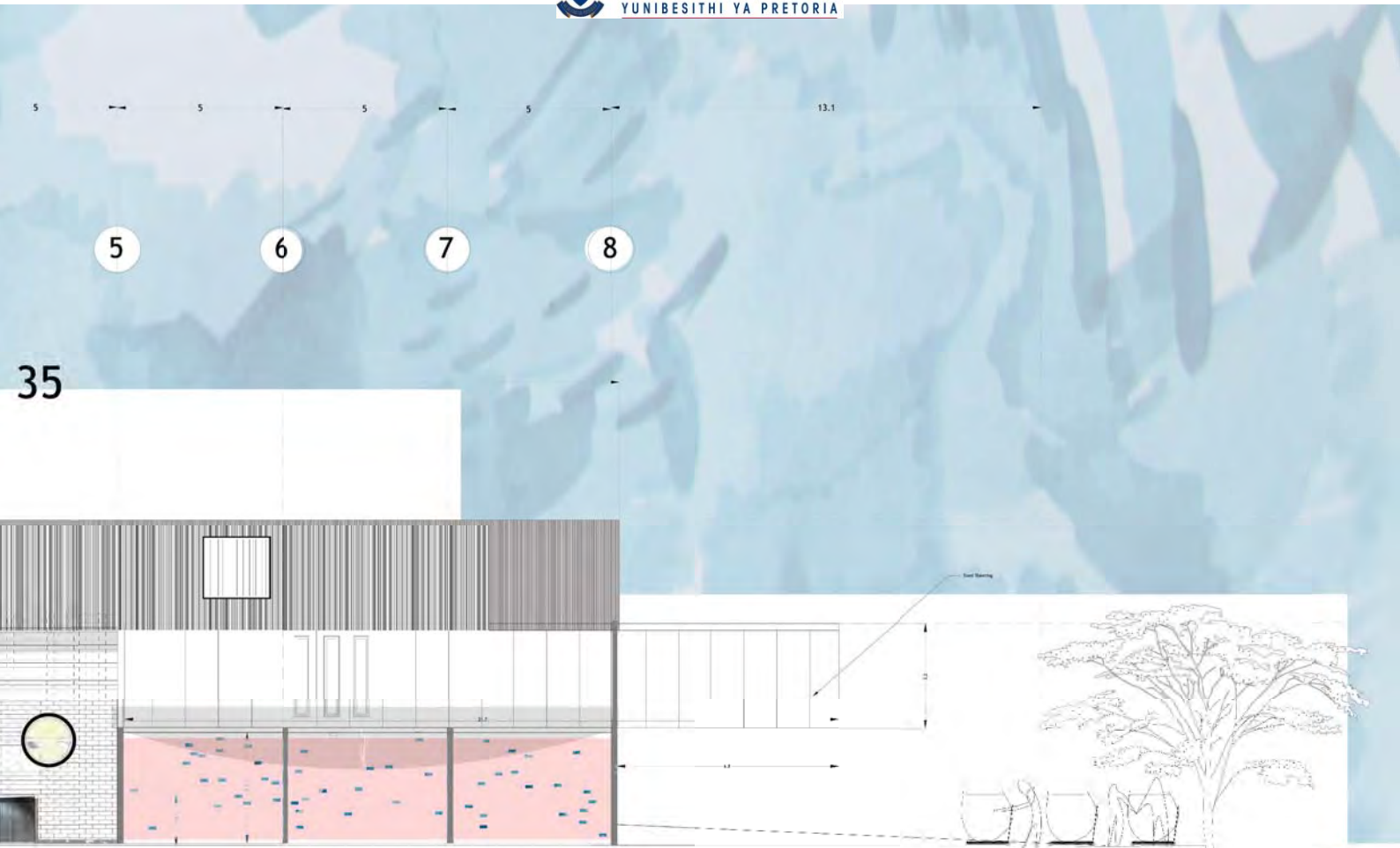

## SECTION OF GALLERY PIERCING

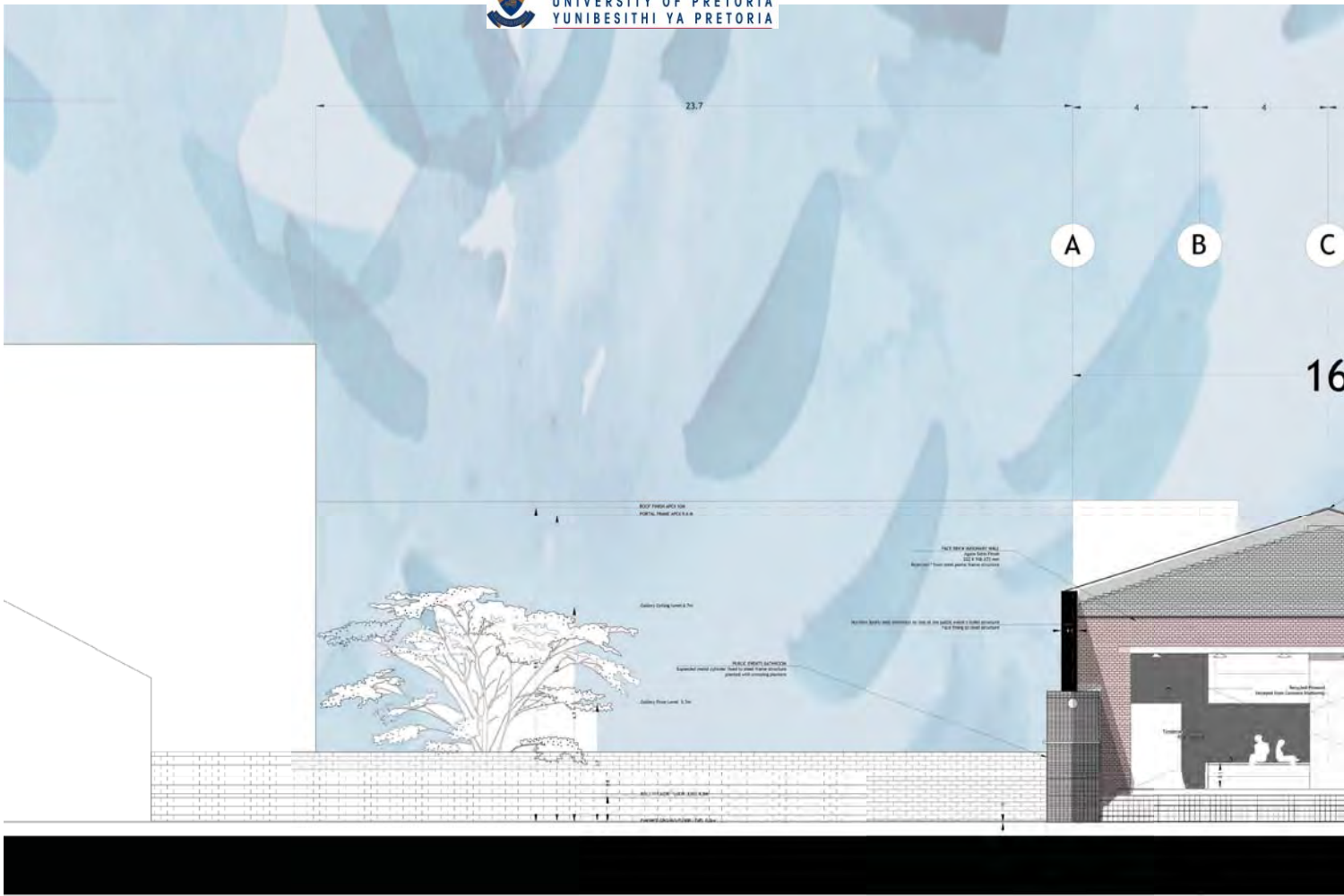

W

REJECTOR | WESTERN ELEVATION OF  
1:100

FIGURE 216 Western Elevation

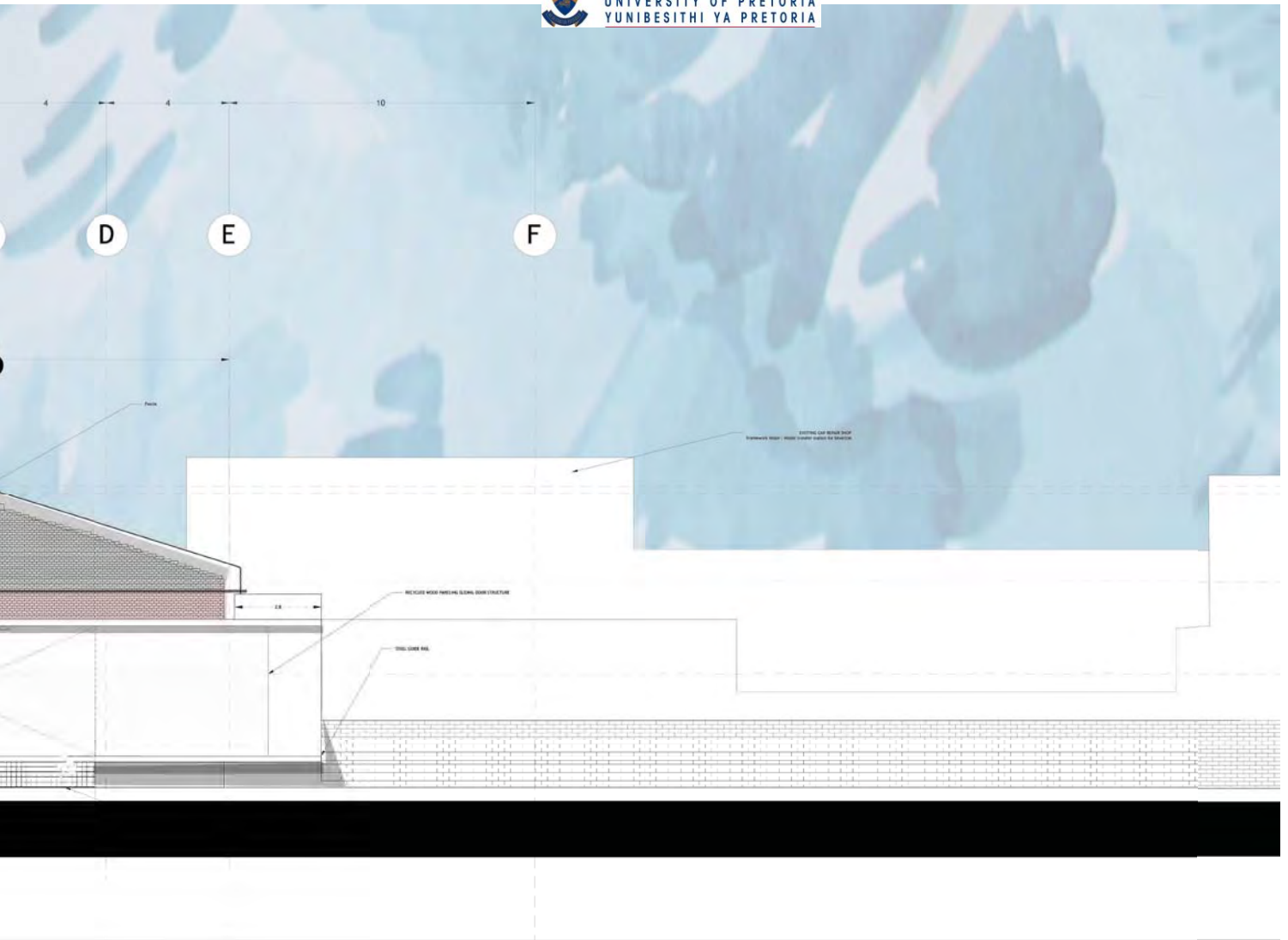

## THE ROLE THEATRE DOORWAY

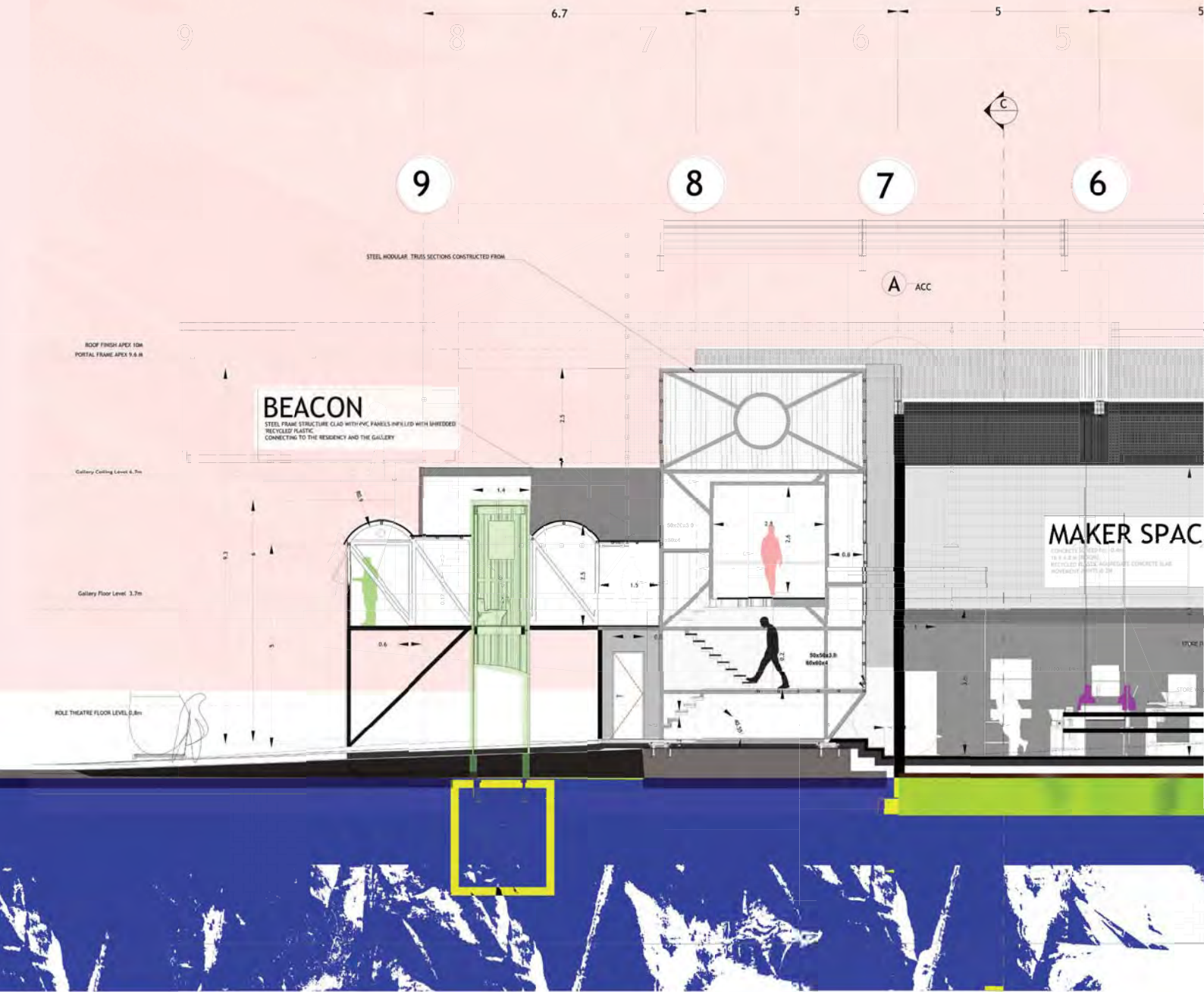

SECTION A  
 STEPPED CROSS SECTION OF THE BUILDING  
 WASOP  
 1: 50

FIGURE 218 Section A



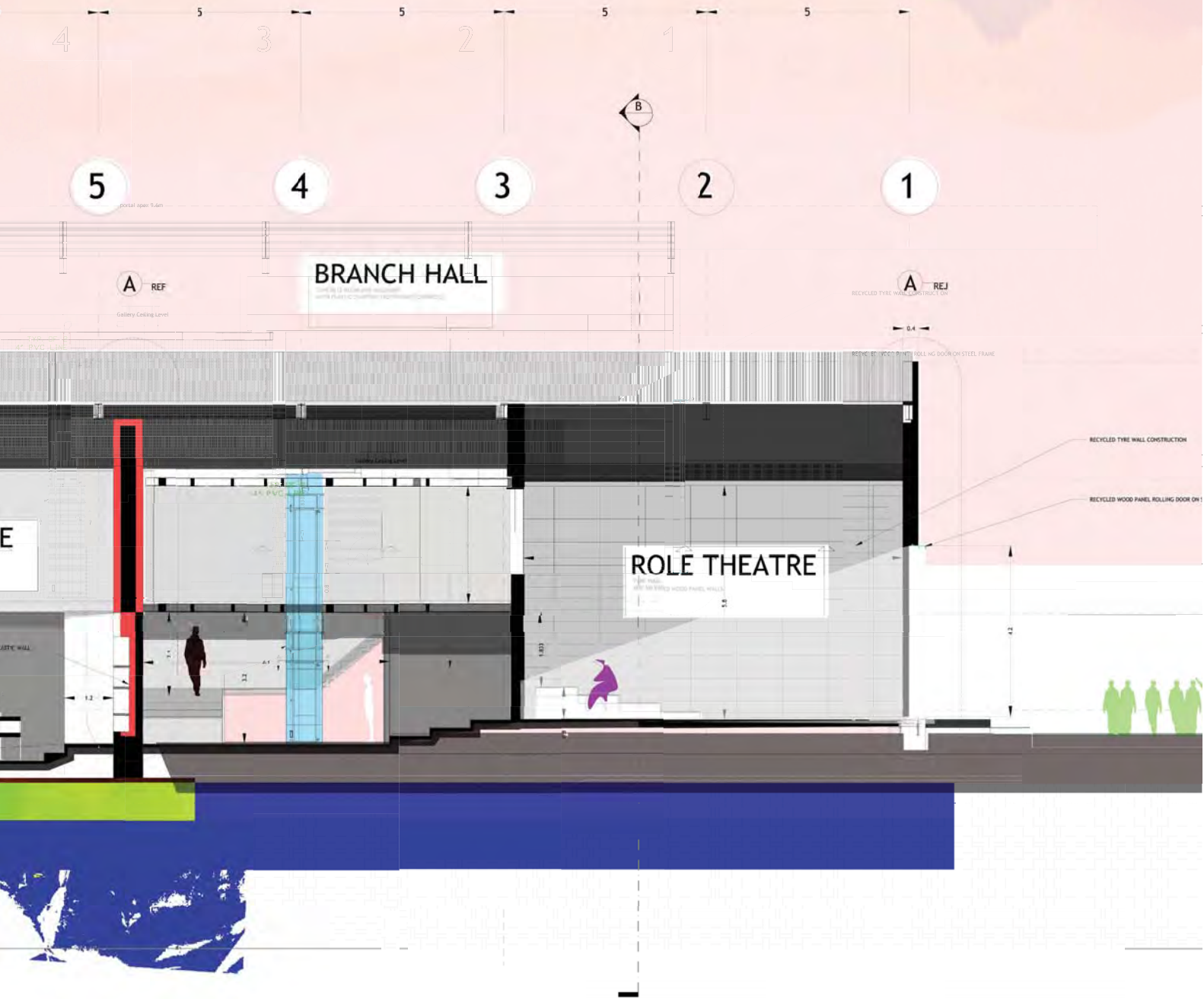

ING : BEACON AND THE ROLE THEATRES FOR FACILITATOIN OF FREQUENCY

