

[reflecting on rejection]

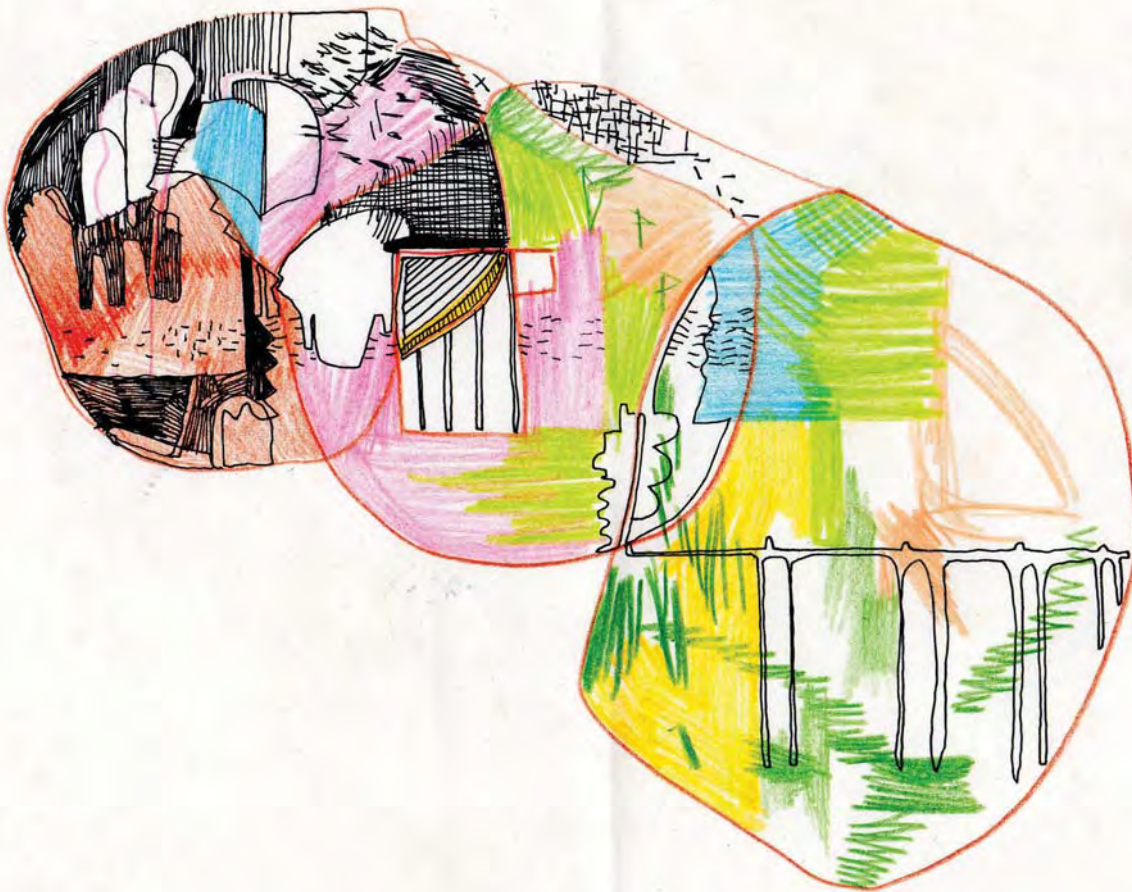
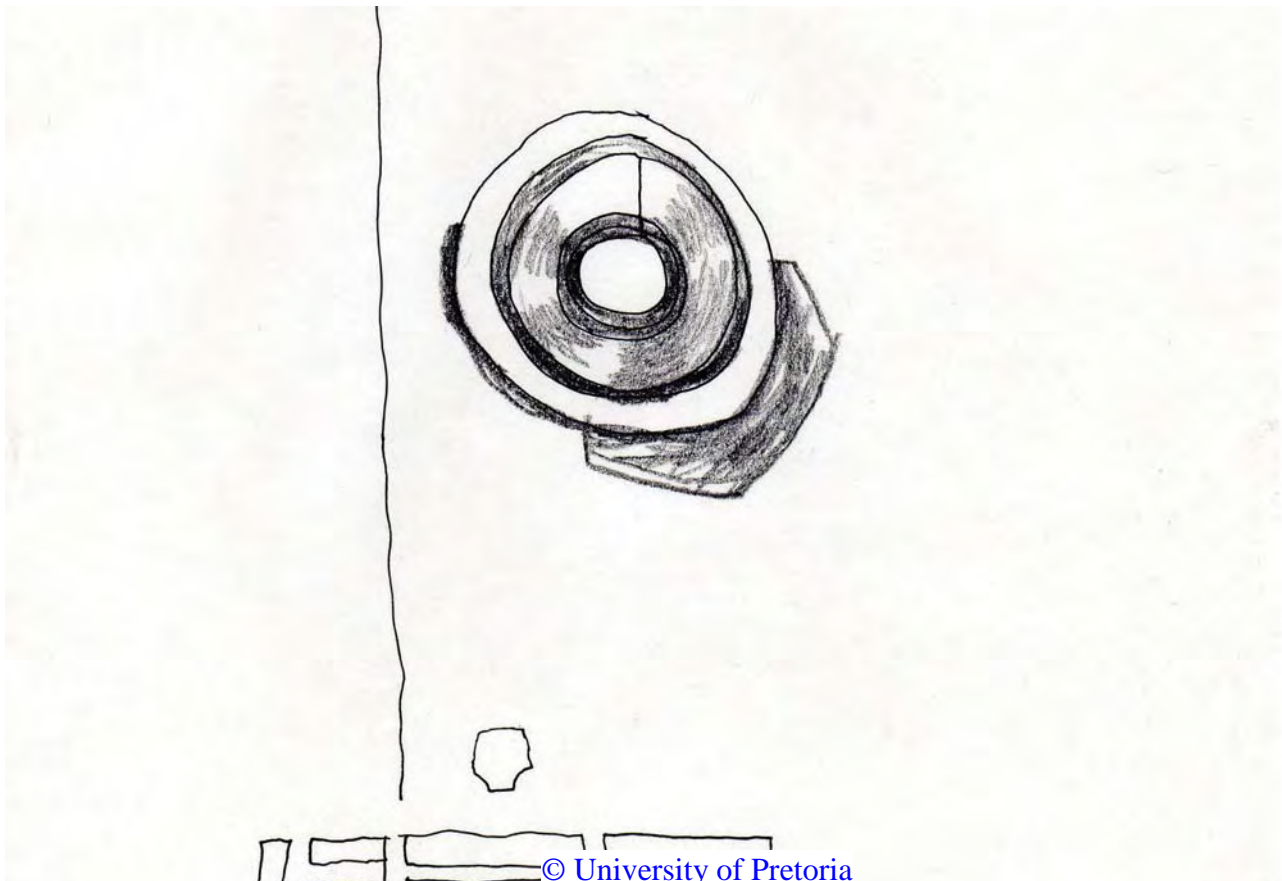

FIGURE 106 Sketch of the spheres of waste and its potential distillation, using colour and line to express a transformation from waste to nature. Figure 96b. An imagined door handle design



07. REVEAL

SPATIAL POTENTIALS





(27)

The transition plane
The column - The vertical



the walls.
the enclosure
the roof
the distribution of energy (downward)
the collector the resonator
the transmitter

the beacon, the heat th
is the place without
energy; yet represents
the form of potential
energy.

all forms of energy.
here: happen. the zero
and the infinite.

walls - it says
beacon walls - plaster

"It is the canon its void
and its walls, its chambers
and its pathway." GARY WHITE

guiding energy of physical
waste to communicate
outwards (via freq) the
message of a medium



FIGURE 108 A later note from a journal describing the place of the beacon - with diagrams of how the beacon and the role theatre and frequency meet and are arranged, IMW 2016

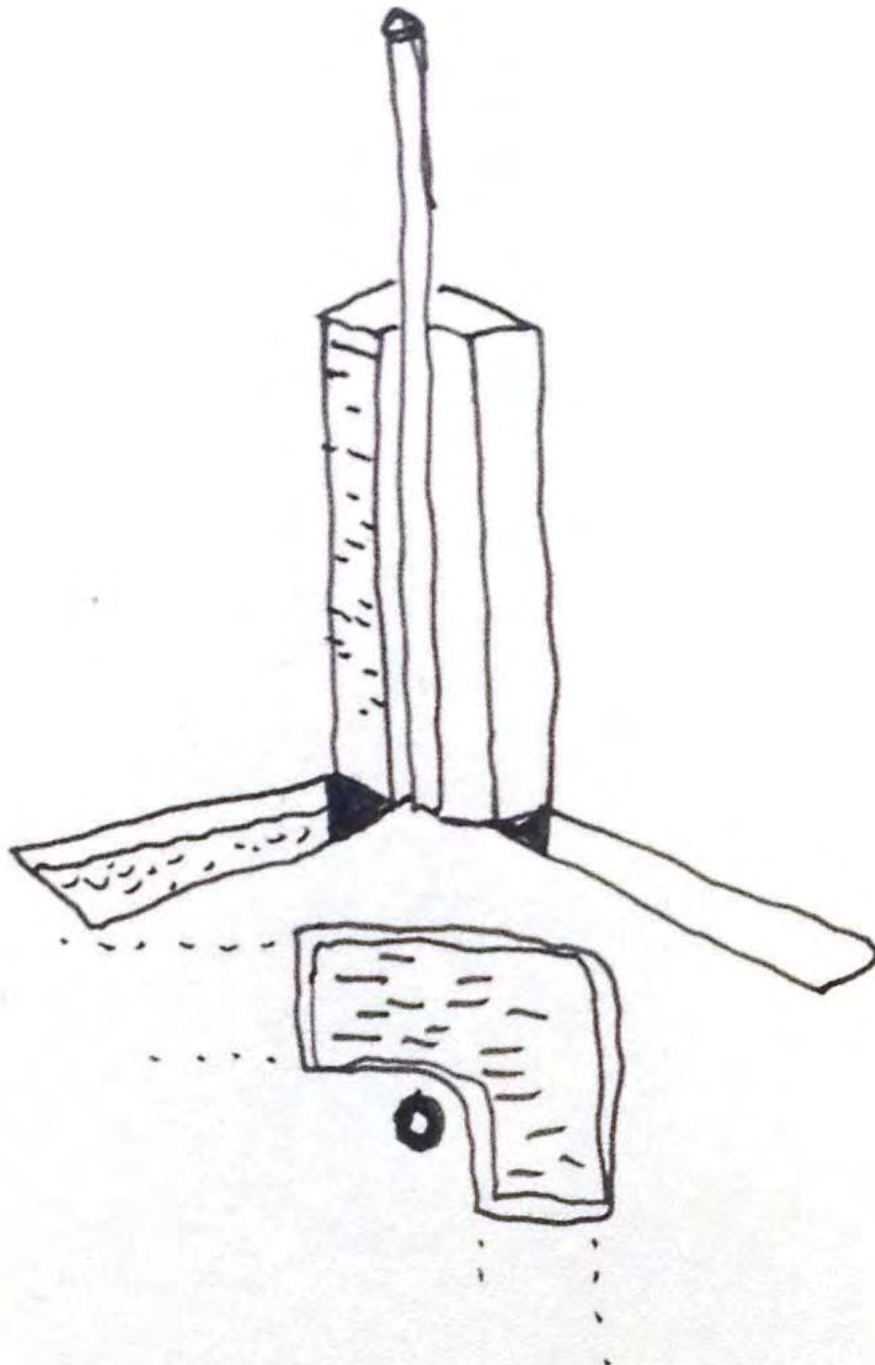
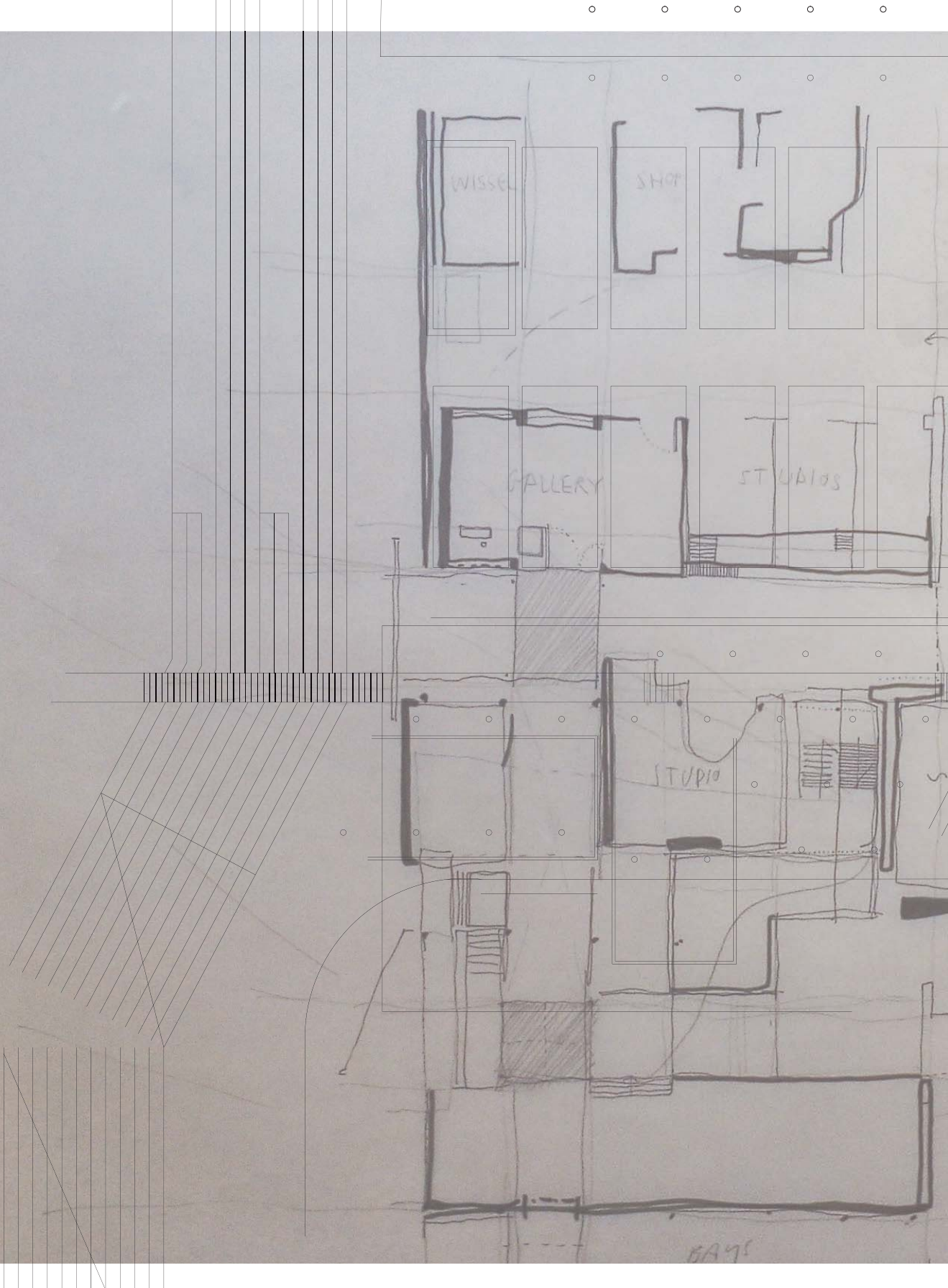

FIGURE 109 A sketch of a column detail
- exploring structure, an infill waste wall
surrounding a column, ie: meeting with
additive materials or constructions, IMW
2016





When you walk INTO the room there is an exhibition of WASTES in the form of plastics shredded and packaged again. Then from this there is a context of AG contours and context and the AU threads that plug into a 3d printed model of small building growing out of an existing shed laser cut from gray board . CONDITIONS cut from perspex and located across the landscape at positions mapped. SLOW spaces then become unpacked, the social facikitation platforms and the beacons working together to generate, channel, resonate, collect and transmit frequency of informations about waste and its potential to those visiting. Defining further the CONCEPTUAL transference from beacon to roof , role theatre to floor and walls and the frequency to the social performance of the building. The THEORIES of waste spaceand waste potentials then becomes furtuer exploited in the perimeter and surrounds of the building as asks how does waste architecture during this phases of accumulation locate itself in such a context. DESIGN has been a process of iterating the cloud of ideas into abstract forms that finally stand in the presence of gravity in the form of details that extrude frequency, inject frequency, and compress frequency. TECHnically branching old and new.

2559/10/11

Sent via vivo Memo

FIGURE 111: An overlay of digital and hand drawings to demonstrate the similarities and differences and also communicate the method of 'Reveal' and 'growth' in design and also is an image that can be used to show beacon, role, platform and frequency early representations, enclosures are the two role theatres of dialogue space and making space, the diagonal lines are earl indicators of stairs which is an extension of the role theatres spaces - relating to frequency Beacon can only be expressed in the vertical elements as an expression of emergence - the beacon enclose had not yet manifested at this time. IMW 2016 Figure 101B: Screenshot of notes on spatial experience of waste exhibitions

This chapter is one of the hardest chapters for the author to write. On a personal level it is related to the spiritual understanding of design and the manifestation of ideas through creation, yet at the same time, architecture finds itself situated within the logic of the sciences that require states of measurement and rigour and so the unpacking of how elements related to the concepts, formed by the attitudes and spatial visions, become translated into space.

Although rigour is used as a means to find the steps and methods for applications, design exists within a narrative state, where factors of daily routine, diet and mood, scenarios, encounters are all factors that influence design - and along the Bergsonian critique of time unit limitation in the science, the author critiques the translation a science into design. Except for a constant reading into other sciences of chemistry, biology, humanity and technology which then go about an method of interpretation through drawing, which may be seen throughout the book.

ACCEPTING REVEALING

The process of design is for the author 'to reveal' that which already exists in the mind of the the architect. The author always knows the story, the intent and the path even when they are lost they are the author of the next step. Design is the testing of languages, which in this case is the language of mediums - the author makes use of drawing which then becomes transformed and spatially tested in model building and then again into drawing with a digital medium.

This year of design has revealed to the author how the was always in her mind and it has been through the creation of drawings as simple lines like the plan on the right all the way through to models that were able to be test the dialogue between language and space. The author accepts that although she often receives criticism of not communicating her

architecture clearly - that this is part of the process by which she creates her architecture, however seeks to finally communicate this method by arriving at a finished and legible building through drawing.

REJECTING REVEALING

The year and its criticism are that which play a part in the process of design - and merely what can be said is that after every critique there comes about a mode of self-criticism - which beckons any designer to question themselves and their methods, however in the very beginning of this book as part of the introduction the author speaks of how intrinsically connected we are to the projects we do - by choice. In the same way it is almost impossible to reject a method - which in this case in described as 'to reveal' - but only to reject that criticism is not rejection, rather a platform for reflection to come about.

REFLECTING OF REVEALING

When processing the information of a project of architecture, ie: drawings and models, the arrangement and ordering of these parts is how an architecture of 'reveal' is created. It seems to the author as if the building has always been there, in every line and every suggested enclosure yet through constantly feeding it more information through consideration of applied thinking [making]- that which was merely grew from the page, branching towards the mind of the viewer - to the realm of being heard as clearly as a conversation about the building to be.

FIGURE 112: Early plan of proposed building, the grey alluding to the existing shed footprint and the pink rectangle to the new building space.

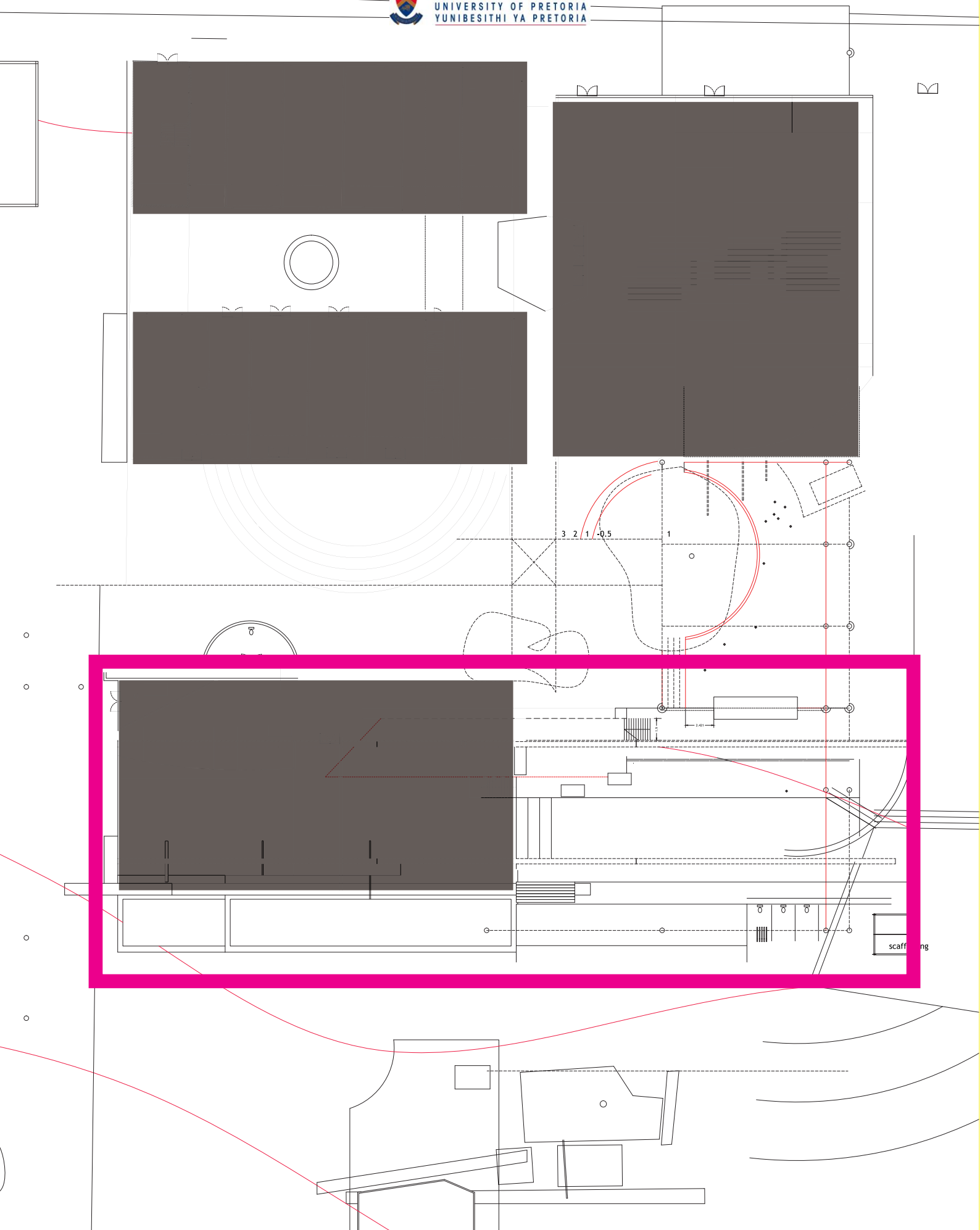



THE ARTIST RESIDENCE

The artist residency design development drew from the author's personal relations to artists and their residency experiences, as well as her own visits to the Nirox Sculpture park situated within the area known as the Cradle of Humankind. The typology of the artist residency is vast, sometimes attaching to existing structures, as this dissertation seeks to do in relation to theories of spatial waste.

In New York alone there are thousands of residencies available for artists working in all mediums, architecture included. Residency Unlimited is an organisation that specialises in providing a source of available residencies for artists to access on a global scale. The artist residency is very much a non-existent program in the context of Pretoria and with the emergence of artist collectives such as SLOWA and Found Collective, there is a need for this typology to be developed.

These relationships with organisation in Pretoria were used as part of an exploration of spaces for different artist[Figure 105] A set of models that were made according to the needs of eight different artists. The sizes of the studio spaces [in white] were based on the medium of the artist. Illustrators needed small drawing spaces and photographers needed dark rooms, whilst sculpture artists needed spaces for casting, moulding, breaking apart and patina spaces. These models served as the language of the concepts and led to a complexity that distracted from designing the public spaces of the building. As the design of space in relation to waste became more defined, it required that the residency becomes more of a single residential module that could be reapplied, rather than a studio for several different arts.

On a visit to STUDIO FINE in Pretoria North, the author was able to access a clear unpacking of the process of fine metalwork in silver, gold and bronze.

The spatial requirements were highly specific to the material being worked with, and at this stage, the decision was made to further investigate the type of studio that was related to waste and metal work studios attitudes to waste were almost of an extreme spectrum of ACCEPTANCE - not letting a single spec of metal dust escape the space.

The decision of materiality relating to waste and art came at a much later stage, and in retrospect, the author has been made aware that deciding earlier on a material informant would have been more useful to the architectural developments. However, through this exploratory method, similarities between waste and precious metals were discovered that further informed the author's perception and translation of attitudes towards the value of materiality, which is in itself, as discussed in the theory chapter and wastescapes chapter.

The concept of the beacon physically responds to the issues of physical waste through the activation of partial waste that seeks to alter and transform the social waste through the image of space.



FIGURE 114: Residency space and form explorations in section sketches. Figure 104B : "The Artists Pool' a sketch of the artists creation space, IMW 2016

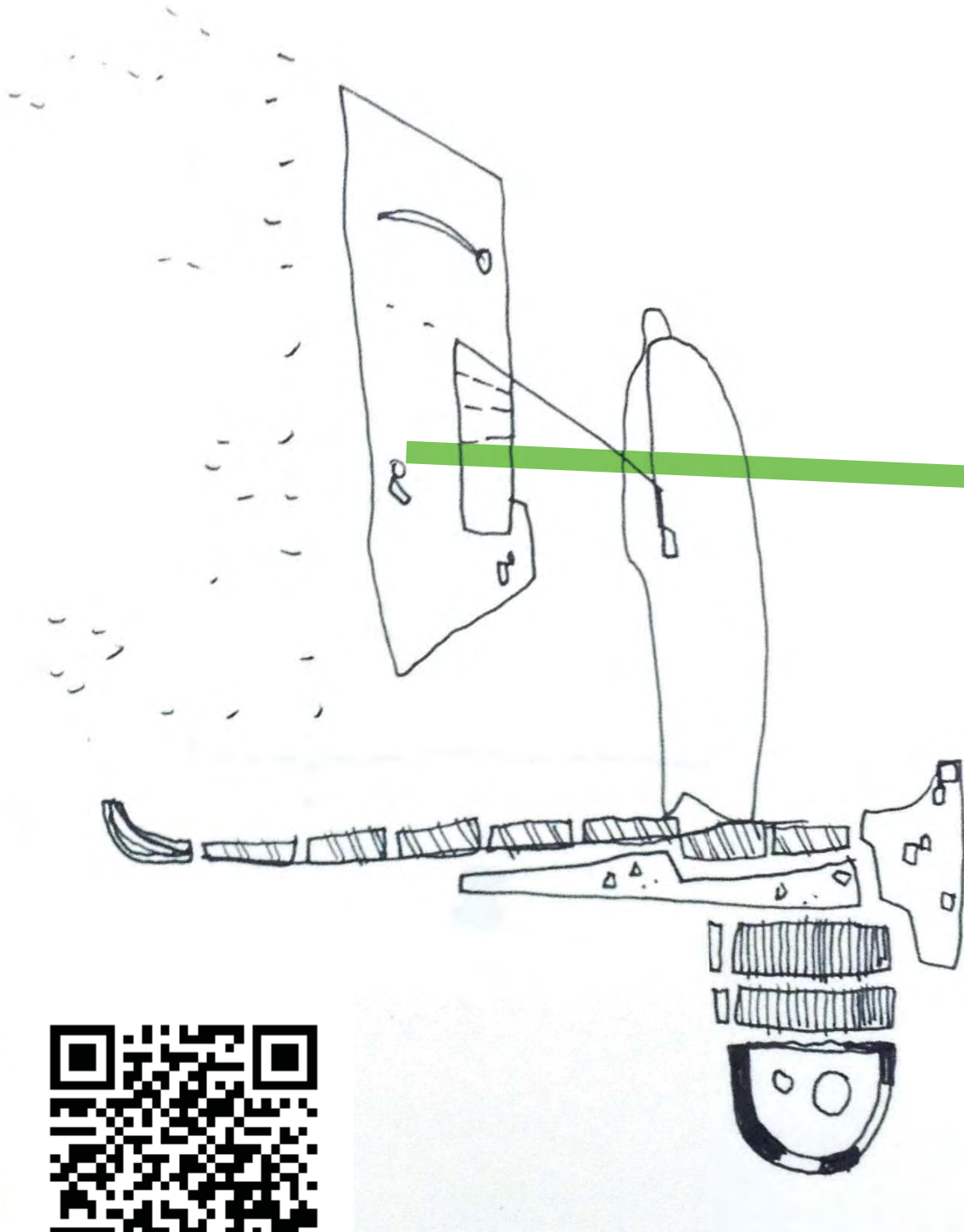
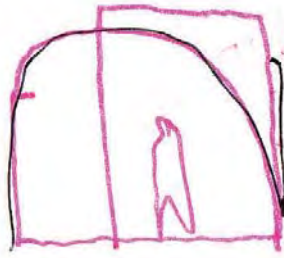
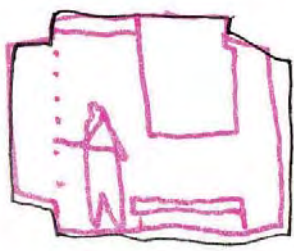

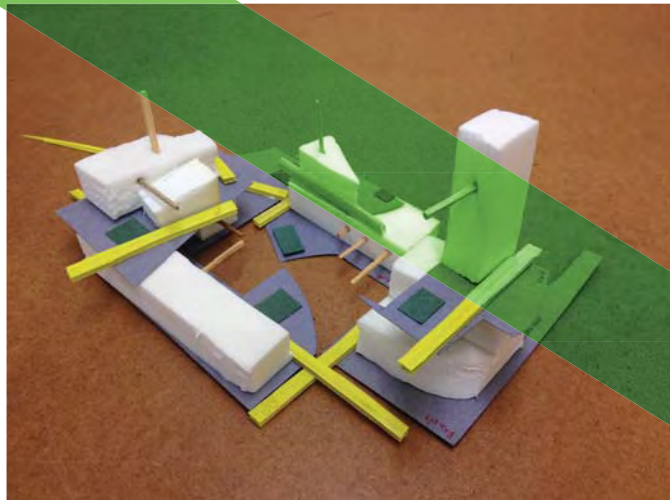
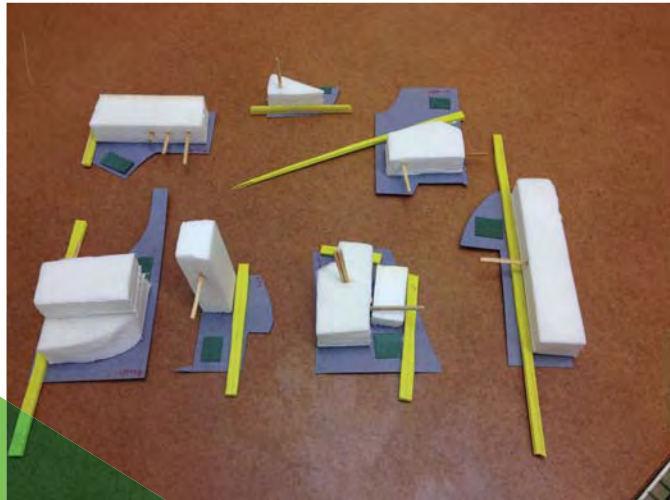
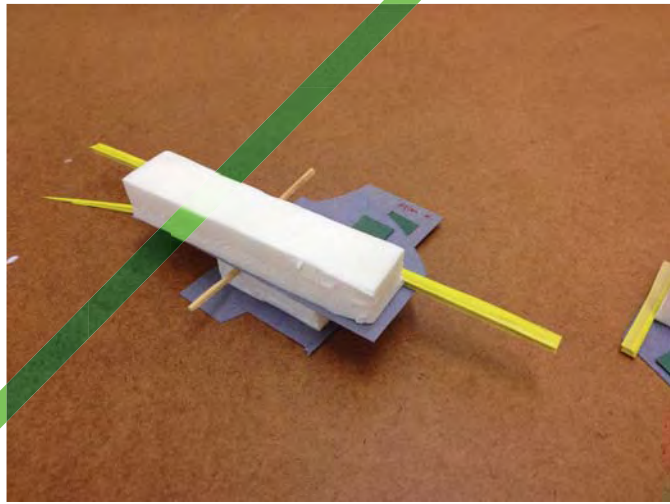
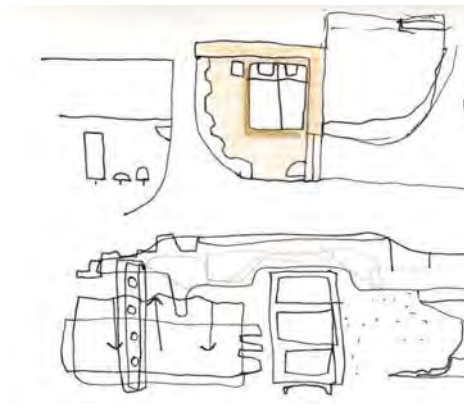

FIGURE 116: Models of artist residency explorations and sketch of the plans of small residential spaces for artists.

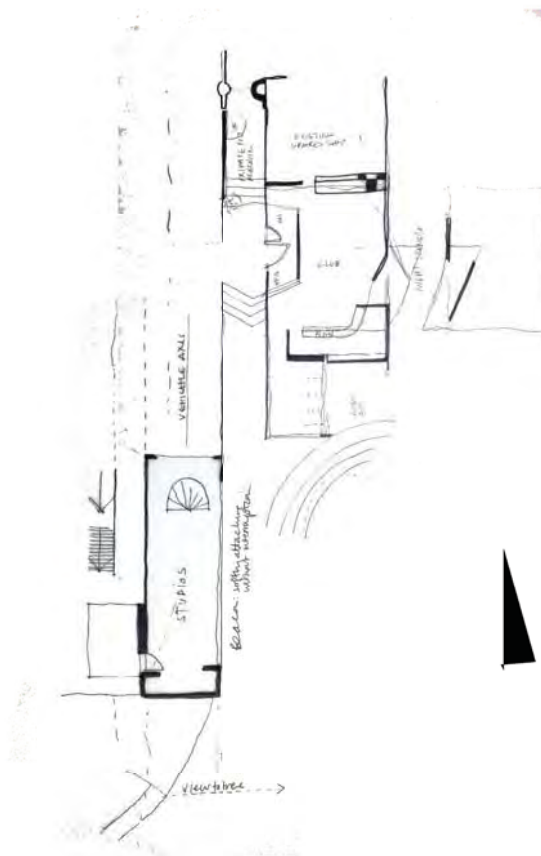
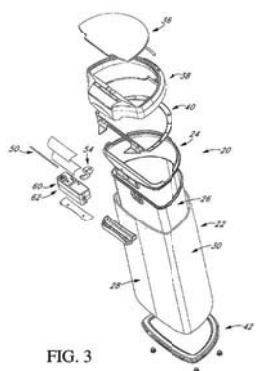

FIGURE 117: Model used to communicate the linear extension of waste into the existing shed building.

Artist residencies

The program of an artist residency is something that is yet to be fully realised in the context of South Africa, but also in the city of Pretoria, which is a hub for artist yet lacks the platforms for their development.

In response to the mapped cond. SECONDED - the architectures see the initial diagram of the 'y' - when either extended into a new di meaning or discarded and arrive point of being ABJECT>



The spaces of social interaction in with artist private studios .

These are the places where WA inserted and also removed - this culmination spaces.

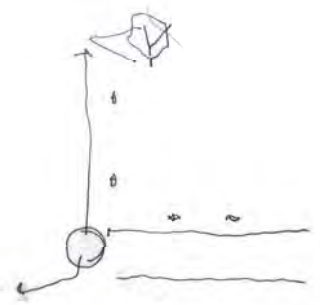

The technical aspects of the program explored through the architectural in the aperture, the opening and how it re CONCEPT of frequency.

FIGURE 118: Precedent, program and writing about the space of the residency - relating to the dustbin of society and references to the Tea house and Nirox artist residency projects.



ition of the
ks to explore
e objects are
mension of
at the final

a conjunction

STE will be
is not the



*PRECEDENT the Nirox foundation, artist residency,
South Africa and the Tea House by Fujimora*

ram will be
mechanism of
esponds to the

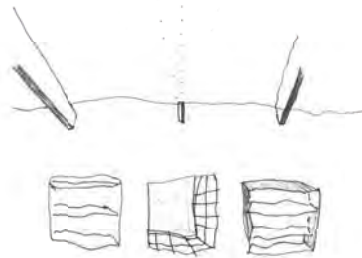



ROLE THEATRE SPACE MAKING AND TALKING SPACE

The notions of waste with their defined value systems went on to inform the unpacking of these concepts.

The space of the theatre role seeks to deal with both value systems associated and defined in accordance to rejecting and accepting of waste.

The role theatre is the facilitation platform - the surface that allows both the tangible and non-tangible aspects of issues relating to waste to be either discussed, presented or created with. Therefore the role theatre manifests itself as both the 'Dialogue Hall' [the talking space] and the 'Maker Studio' [the making space] .

The maker spacer was always central to the design - as its served as facilitation not only of the spatial waste and physical matter, ie; dealing with matters on waste - but also specifically with social waste - in other words creatng spaces where social potential is activated - spaces of discussion and spaces of collective creating .

The role theatre pertains to the floor plan of the building - wheras the beacon for example makes reference to the 3dimensional experience of the building as a whole by which to guide visitors and

function, the role theatre makes reference to the horizontal floor plan specifically.

To the right is a section of the dialogue hall which overhead piercing into it is the the overhead gallery - which serves also as a mechanism of the floor plane but in connection to a different aspect of the program.

Upon the ground floor there exist a set of exchanges that are facilitated through changes in levels. The entrance lobby role theatre were the exchange of inside to outside occurs is level- whereas the level changes upward into the dialogue hall platform - as an expression of an elevated experience of collective and maximised multidinal exchange - but not steps down not in a ninary understanding of opposition but rather as complimentary and balanced into the sunken work space of the maker hall --- where the step in [the artist pool carried over into the maker space platform] - allows for the containment of waste. Each role theatre space- as an enclosure also deals with inlets and outlets of energy -standard size entrance in relation to oversized exits or vice versa. The relationships between openings and the planes of the role theatre will be unpacked in the conceptual transaltions of frequency into design.



FIGURE 120: Sketches of different spatial requirements and sections for the spaces related to making and talking.

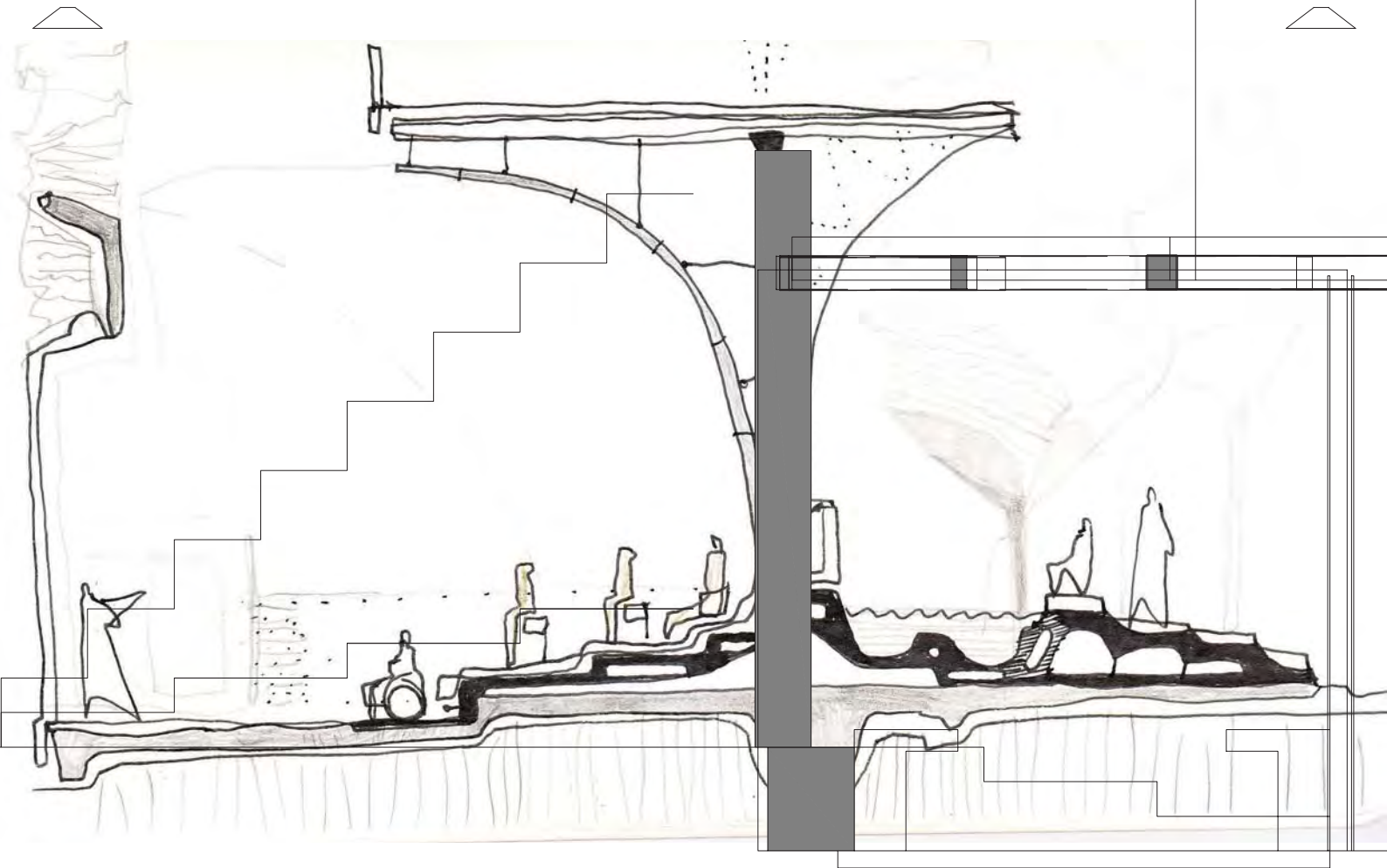
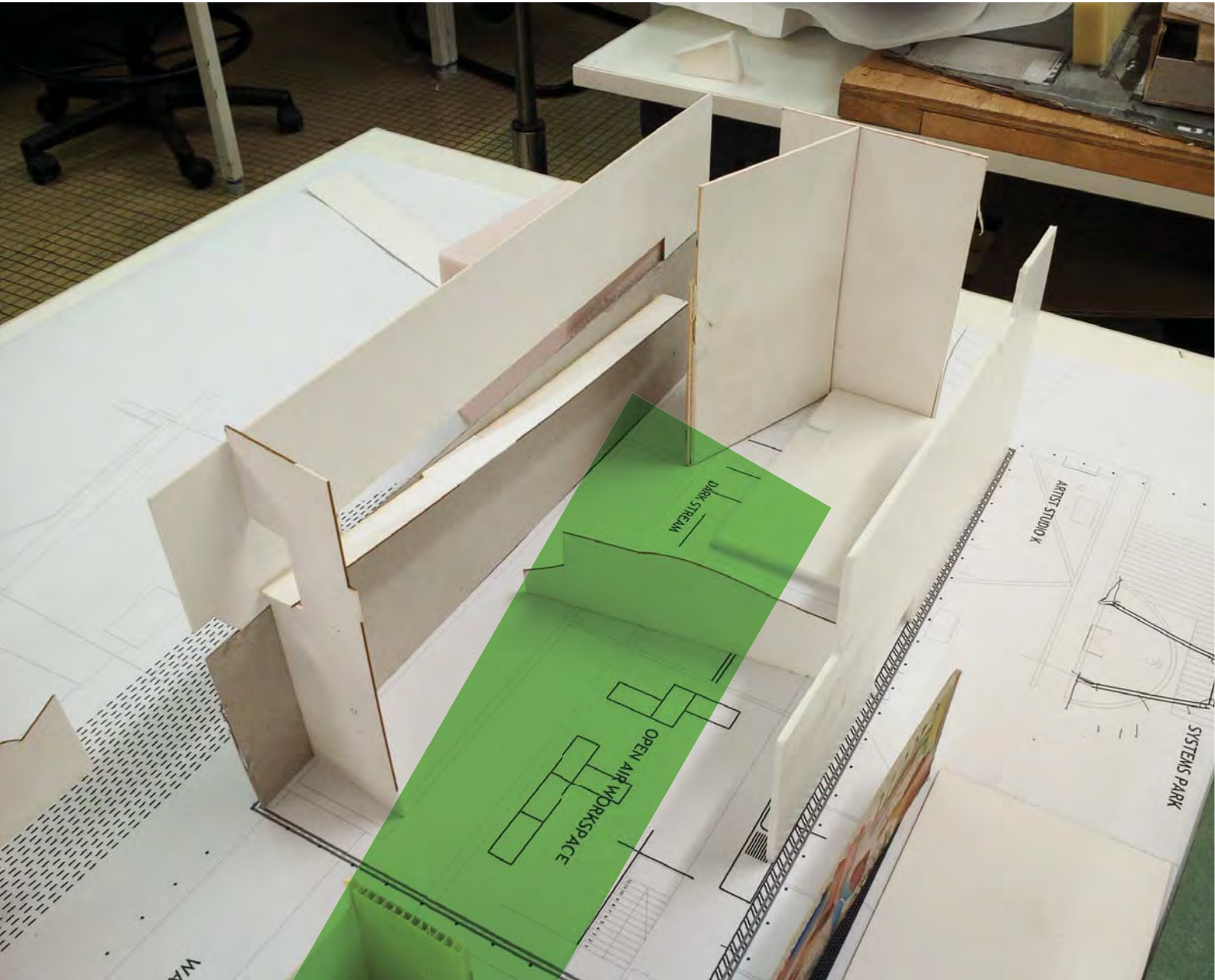



FIGURE 122: July model show dialogue space in relation to the above gallery and circulation. Figure 112b: May model of maker space as the open air workspace similar to industrial spaces



Talking spaces

Spaces where accepting can occur - but also all the other social factors 0 but mostly where there is pure dialogue, information in the form of real and digital content but with an interface with the outdoor - the relation between virtual and real is neccasary in a culture migrating more towards the escapism of the unreal.

The diagram of the lawnmower is referred to as a way to explain how the space is destructive, but curation and meditation yet labourious all at the same time.

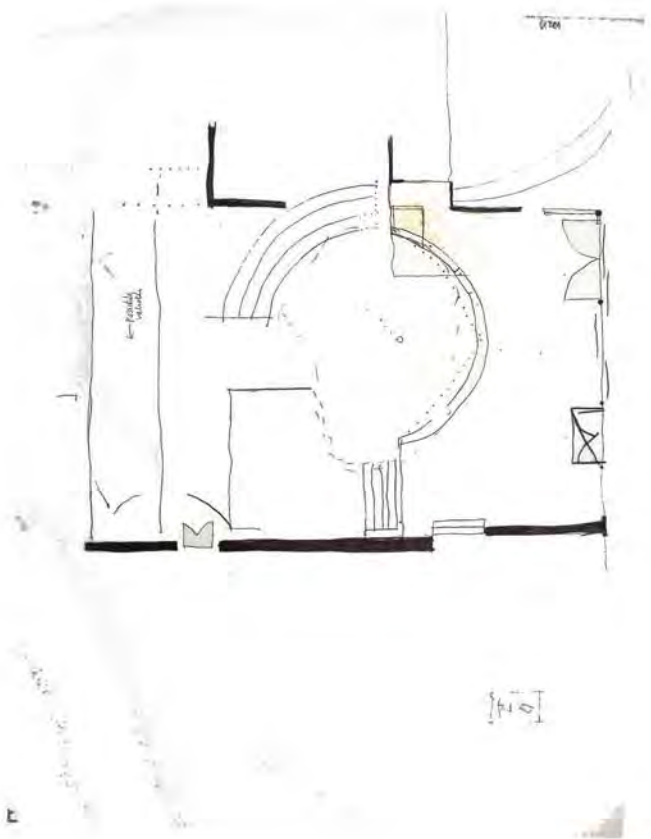
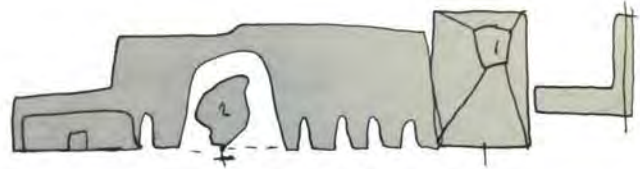

The spaces the PASSE the frequ condition.

There is a this needs age - the y

Spaces of t distinction rejection through re

The techni which the explore in

night ●



FIGURE 124 Precedent and spatial concept and requirements poster for talking space, IMW 2016



*draw from the mapped condition of
DANGER - and require the response of
agency concepts derived from this*

*variety demographic in Silverton and
to be considered for the spaces - the
young and the old.*

*the outdoor - where there is no social
and only the witnessing - of the
of the acceptance and remedies
reflection.*



*PRECEDENT , Cory Silva masonry ramp stair
design*

*cal resolution of seating is the detail
architecture seeks to incorporate and
making.*



Maker spaces

The workshops spaces are to be integrated into the transfer of waste and then into the transfer into gallery spaces.

Requiring mechanical space, storage space and transfer, rejection, accepting and reflection spaces.

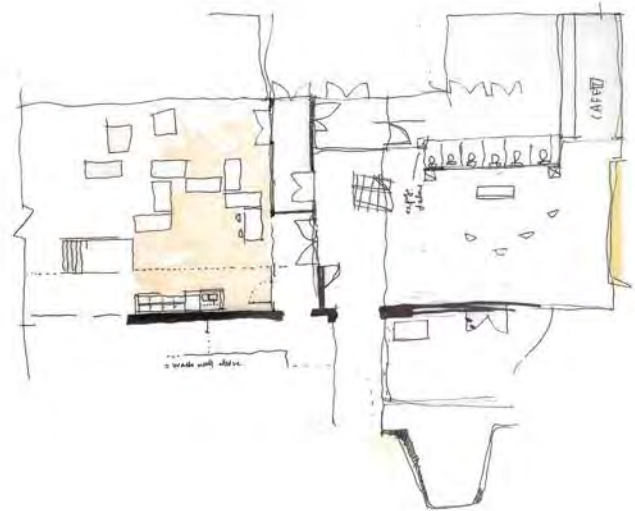

Exp
TR
in
exc

Spa
and
the
hap
alth
culn
ABS
colle
by a

The
hum
spac
the

FIGURE 126 Precedent and spatial concept and requirements poster for maker space, IMW 2016



exploiting the mapped condition of
TRANSACTIONS

the spaces of social and creative
change.

cially there is a need to intergrate, intersect
emerge - the accepting, the rejection and
reflection on making is something that
pens in the spaces of making ---

ough the workshop spaces are not the
minating spaces - they can be described as
TRACT CULMINATION spaces - where
ective action culminates in ways undefined
ny value



PRECEDENTS Renzo Piano and SAND studios

artists pool is where all members of
community become the artist - the maker - these
spaces are described as pools - this is because of
need for containment of sound and of mess.

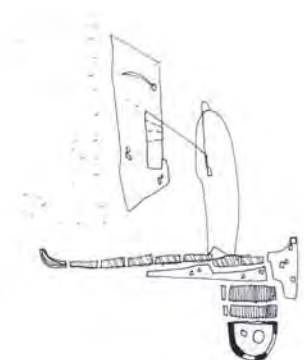

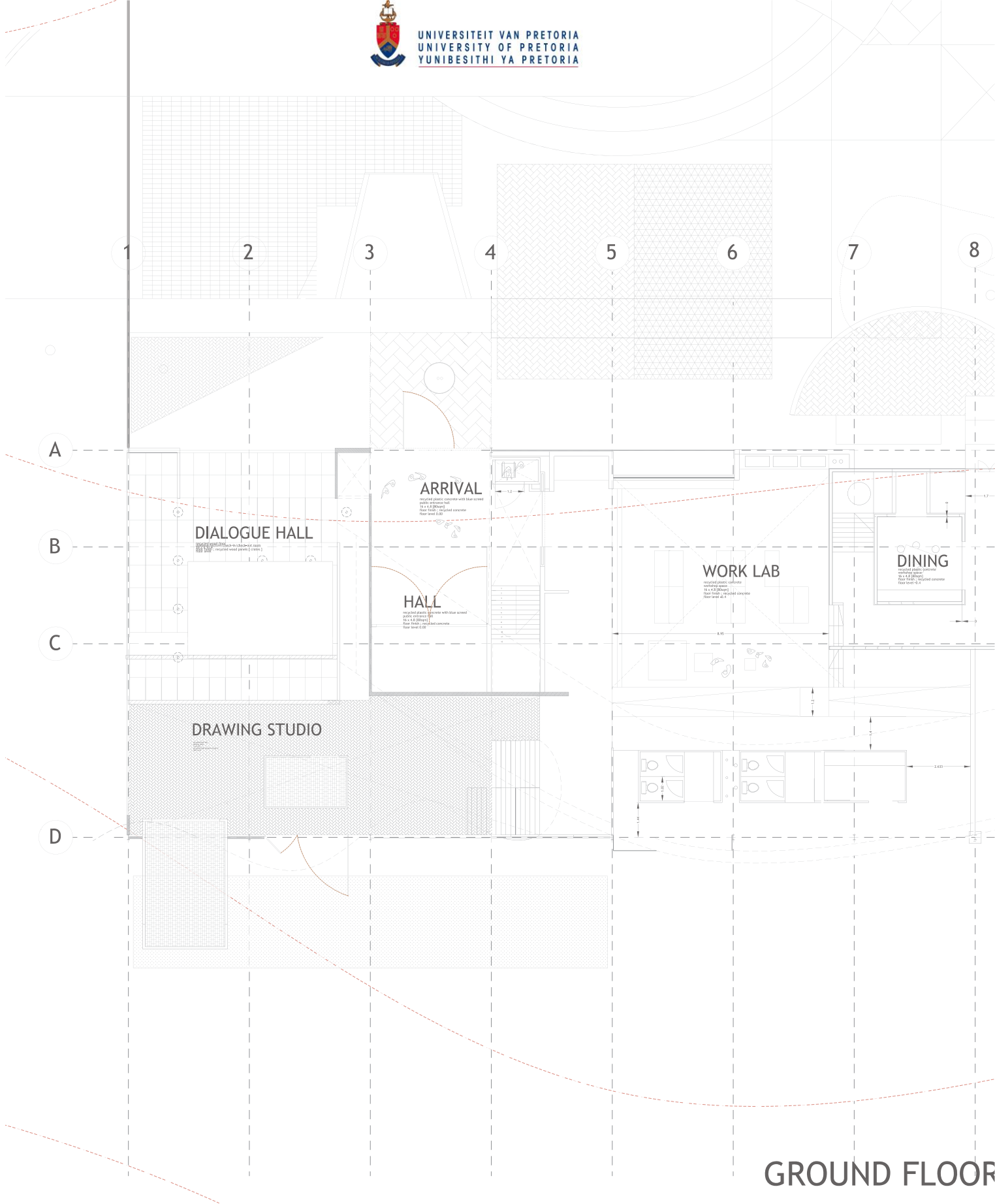

FIGURE 128 Ground floor sketch plan overlaid with gallery curve overhead.

UNIVERSITEIT VAN PRETORIA
UNIVERSITY OF PRETORIA
YUNIBESITHI YA PRETORIA

FREQUENCY SPACE VIRTUAL SPACE

The frequency spaces are related to definitions of the social waste, physical waste and spatial waste and recognises the fluidity of use, time and of architectural elements as systems related to patterns, seasons and the unexpected.

These spaces are the entrances, hallways and corridors places of movement of the human body through space, but also culminate in the gallery which is a space that itself becomes matter in motion and forces the human motion to frequently change and be altered through its own set of arrangements.

Frequency space connects to attitudes of accepting, reject and reflecting - and for the clearest examples of how frequency has been understood in this project - is to radio waves, their transmissions, the forms and their resonance. The beacon not only acts them as a transmitter but also as a resonator - collecting and projecting information - it is a static object which is in fact vibrating with energy beyond that of an intangible translation - it can be heard - as a process of shredding plastic finds itself embodied

The building itself and its design has been a fluctuating frequency of brainwaves that have been captured, transmitted and muted over pages of sketches and drawings- which are to follow.

The frequency element

which situates itself as an elevated slice of earth shaped by the frequencies and flows of a prehistoric landscape. Emerged to facilitate the transformation of attitude through the arts of physical, social [dialogue] and spatial [architectures].

The following images are conceptual elevations created with a range of different types of ink, marker and pencils.

These elevations were then translated into a more regulated, ruled and formal elevation [see bottom right]. This process of conceptual explosiveness' with only the framework of scale, then becomes the symbolic and emotional expression of the building - which then as seen in the formalised elevation, becomes regularised.

What then happens with these two very different spectrums of designing is their intersection, not so much on a physical overlaying method of say - using a light table, rather through the use of modeling.

This has been emergent in the way of designing in this dissertation. The 2-dimensional drawing, although it is the image of the 3-dimensional object, is the tool by which to inform the 3-dimensional and thereby the 3dimension becomes the tool for testing and thus goes on to inform the 2-dimensional, which is then formally, conceptually and finally expressed in the 3-dimensional drawing; the perspective [See Figure 128 on the following page].

FIGURE 130a: Development of branch logic into plan. 114b: Gallery final floor plan sketch, IMW 2016.

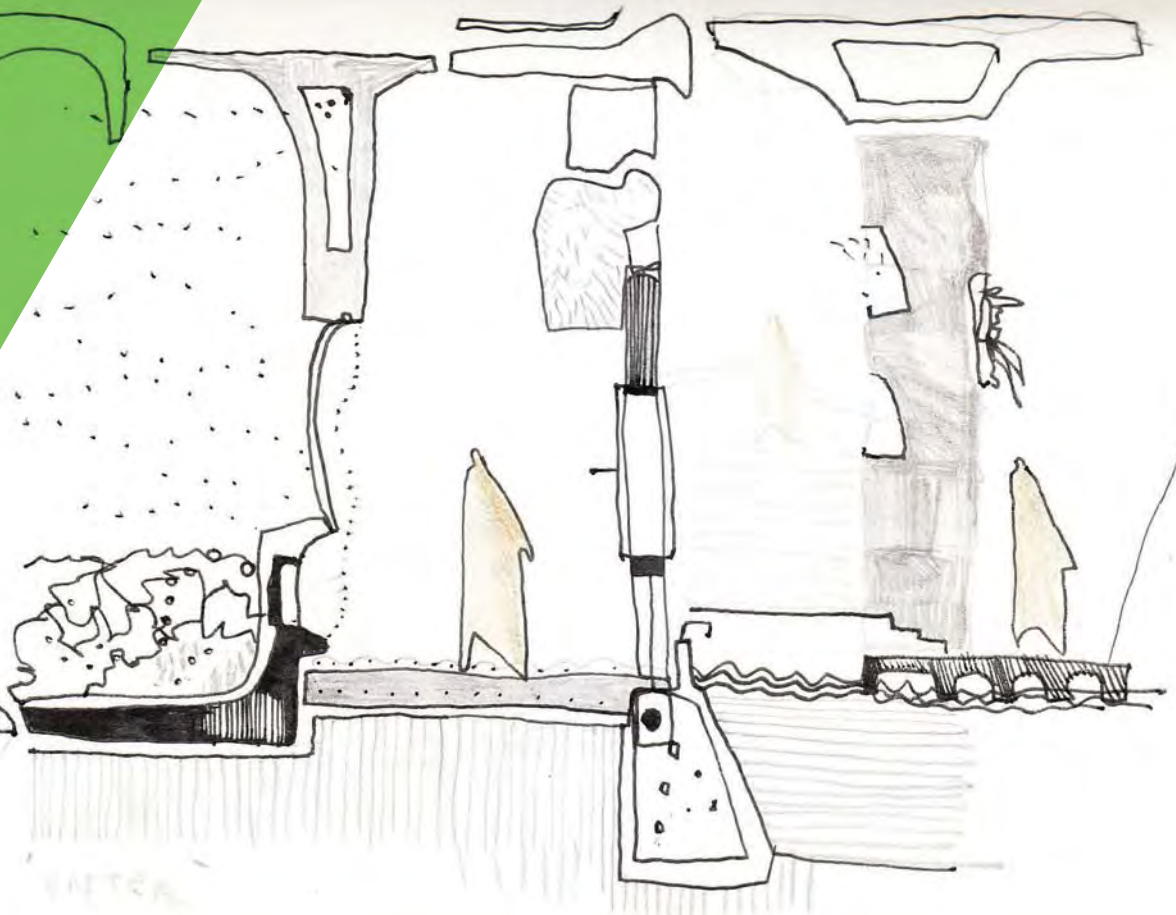
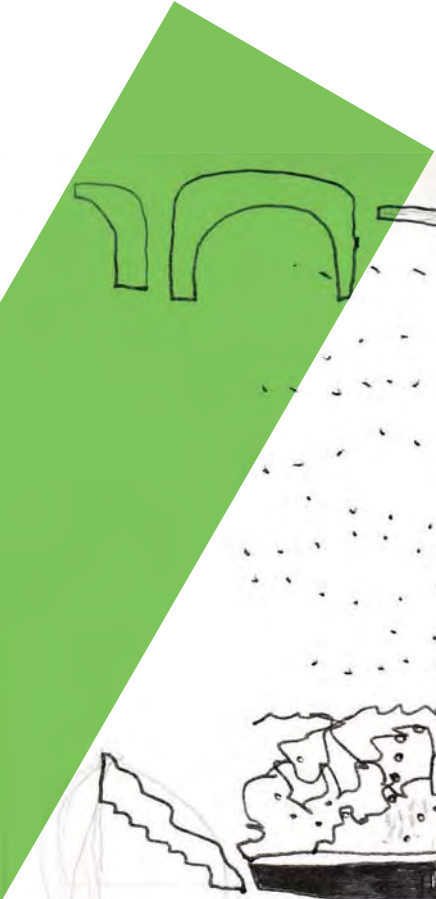
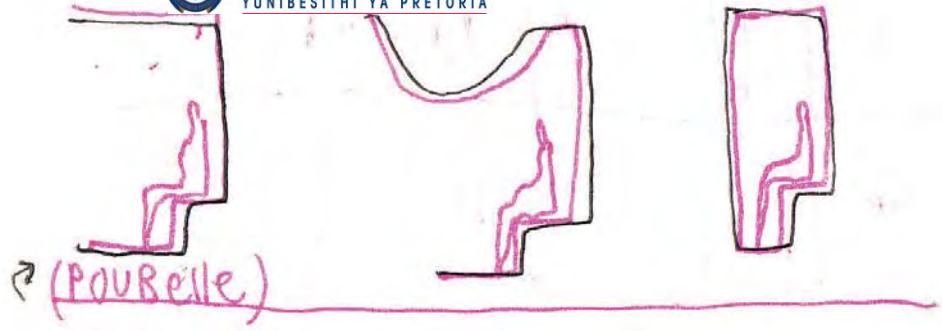

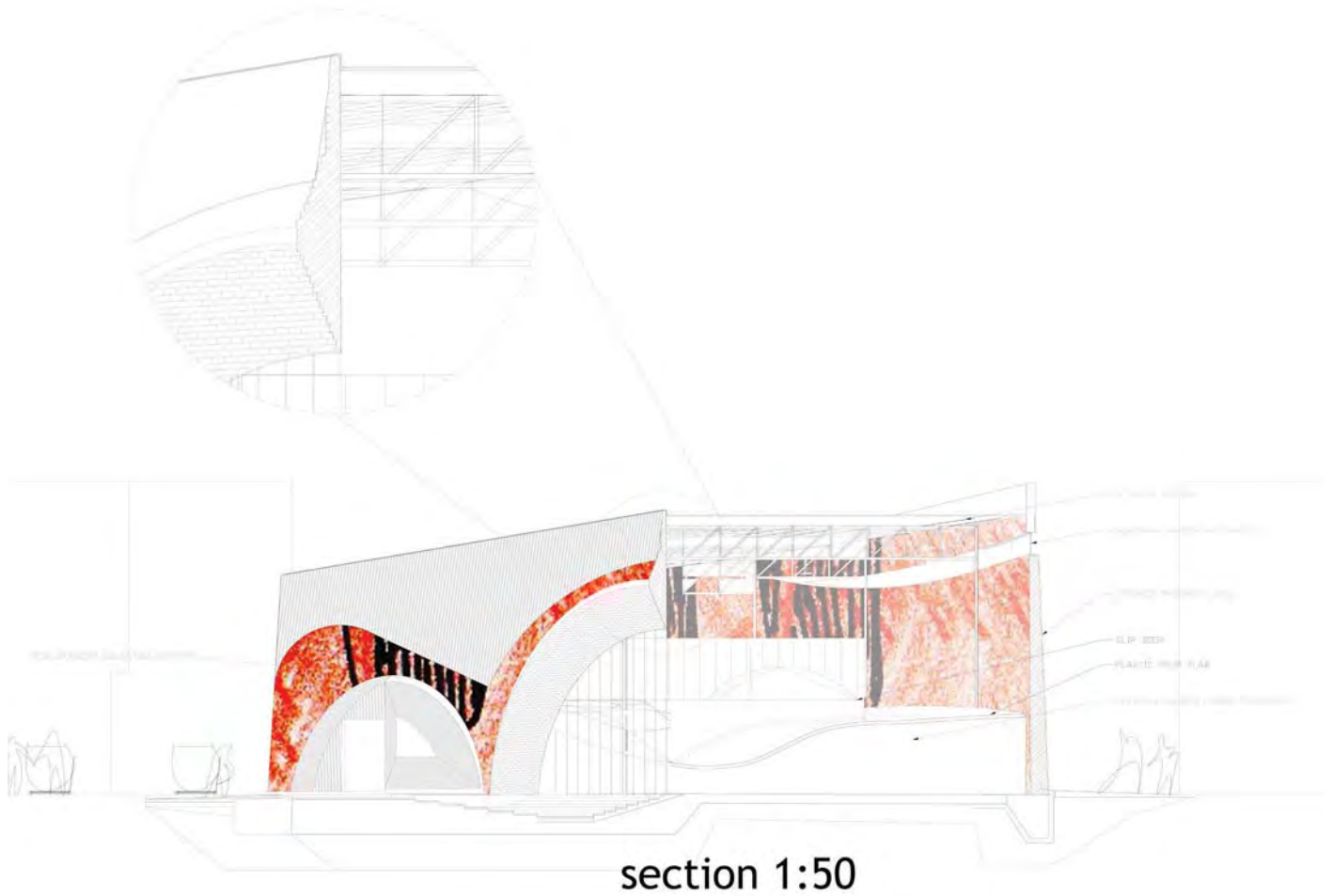
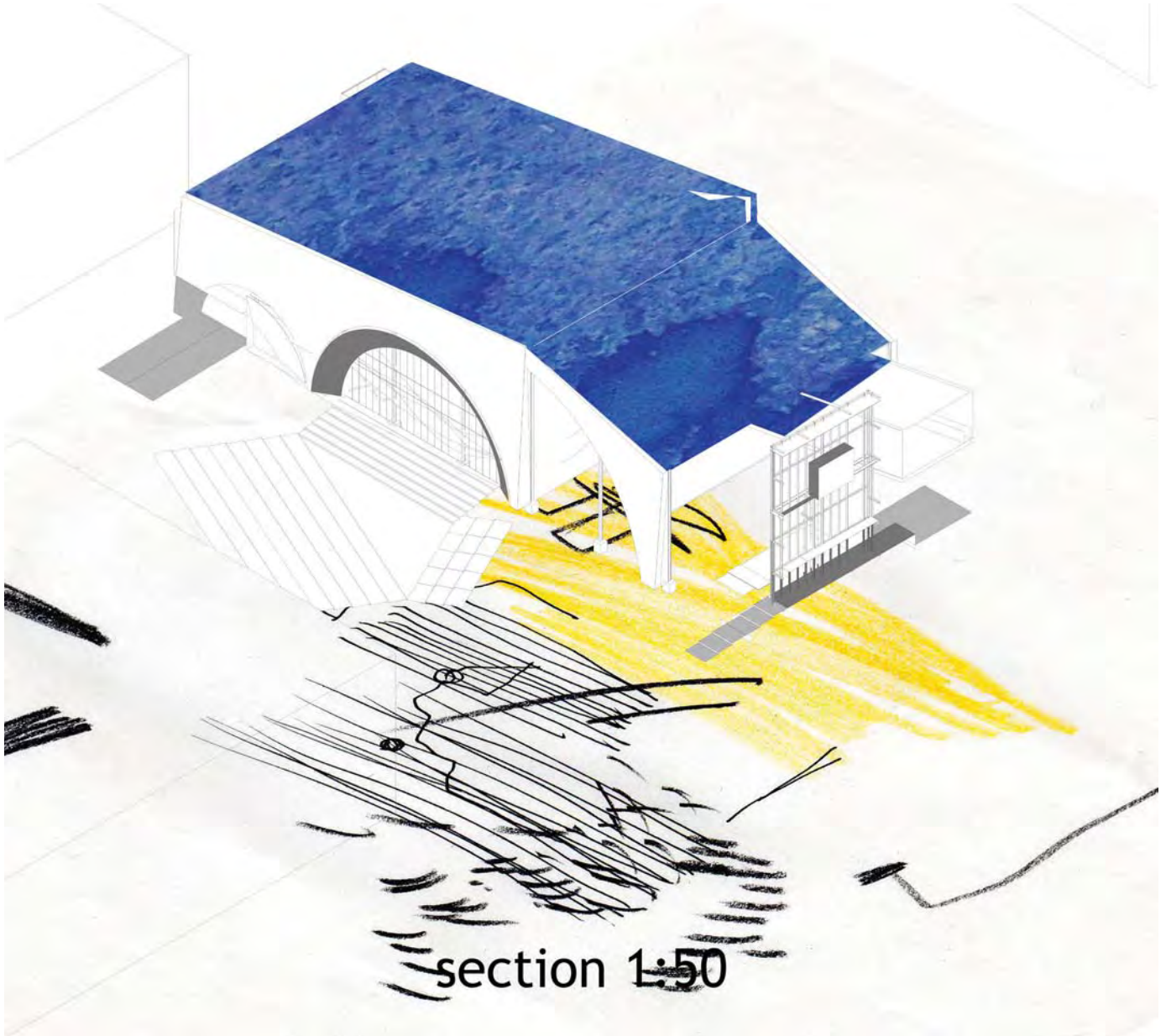

FIGURE 132 : Sections of the now removed warehouse of recycling distillation



[http://
tomassaraceno.
com/projects/on-
space-time-foam/](http://tomassaraceno.com/projects/on-space-time-foam/)



FIGURE 134: 'On Space Time Foam' by Tomas Sareceno is an installation at Hangar Bicocca in Milan (2012-13) which illustrates the dreamy spatial potentials that can be explored with a material such as plastic. The QR code can be scanned to access the image at the following <http://tomassaraceno.com/projects/on-space-time-foam/>



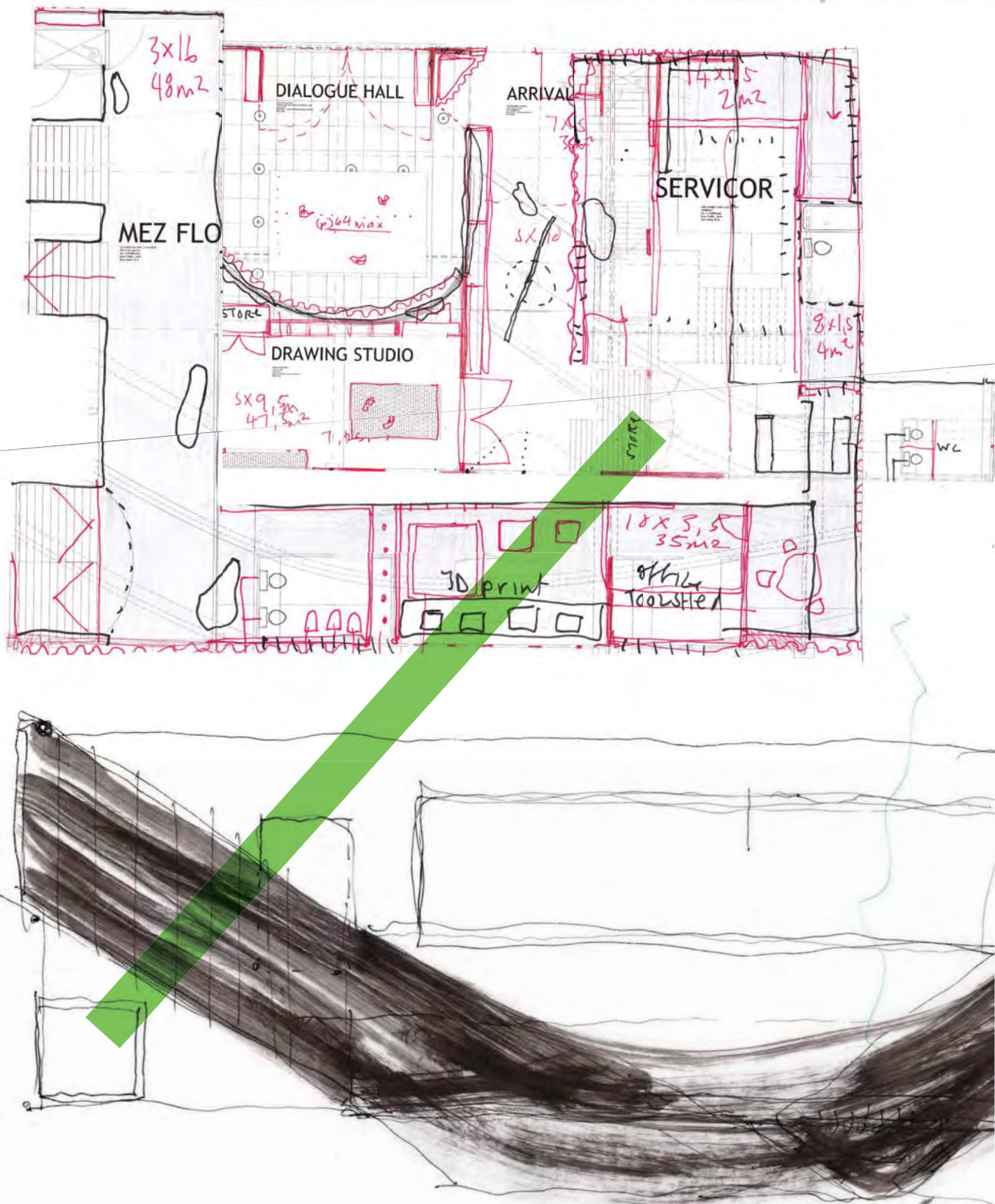
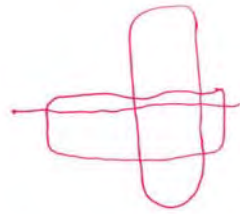

FIGURE 136: Plans in progress, from sketch to print to sketch plans and paint plans reinforcing the branch logic into space.



upstart / movement innovation



BRANCH
logic
development



1 (g)



2 (g)

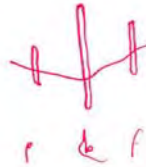

r f



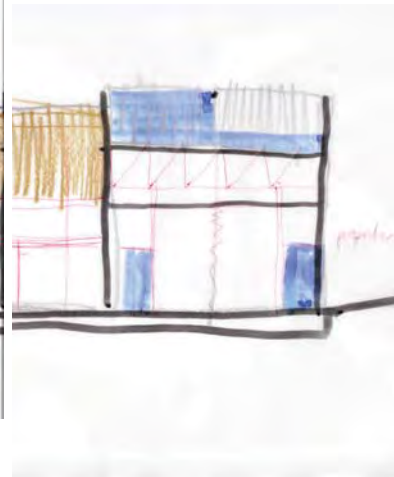
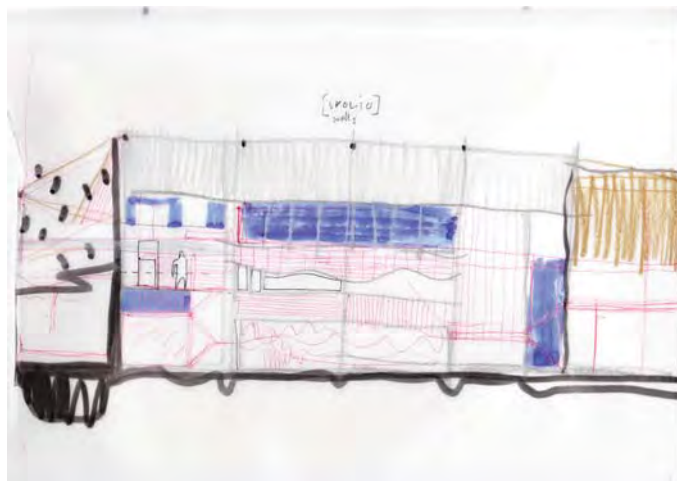
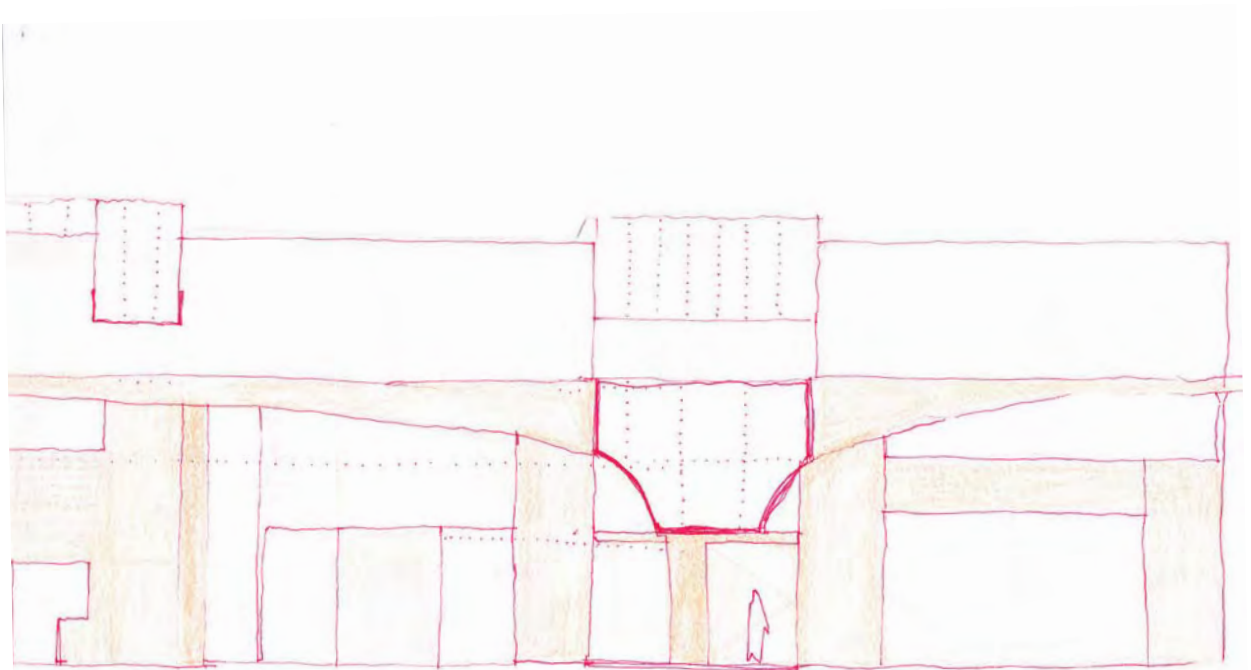
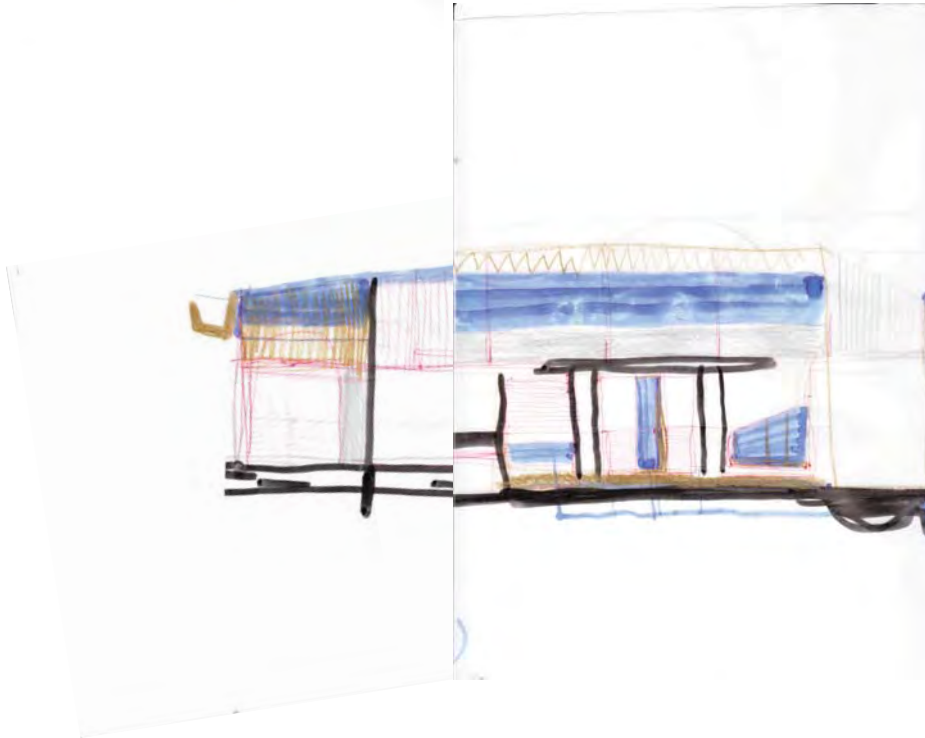

FIGURE 138: Conceptual elevations for the building north and south. Gold represented plastic construction, blue is that of aperture or transparency, red is brickwork and black concrete.



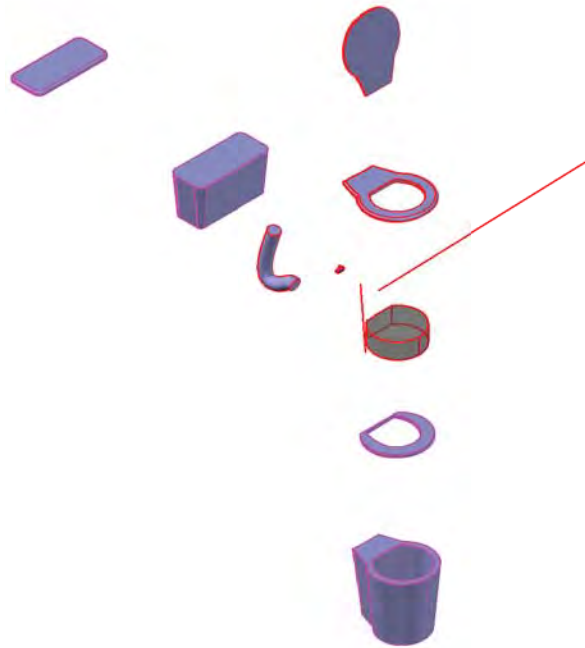
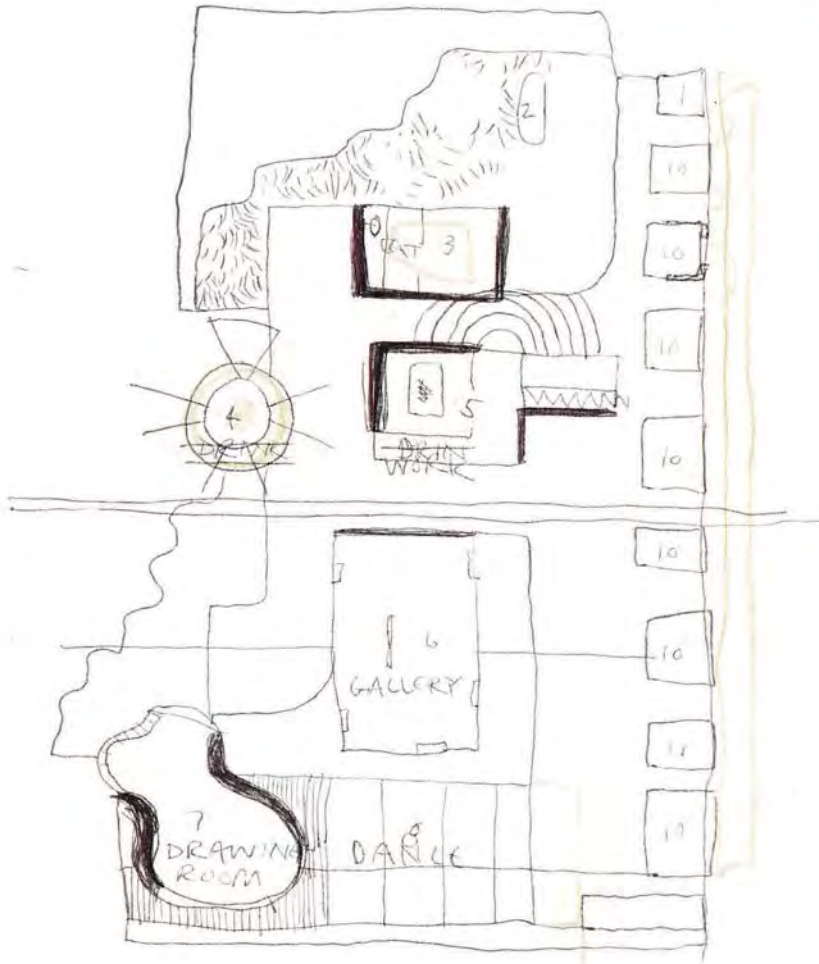

FIGURE 140: Explosion of a cad modelled toilet and explosion of the program of the building.



namiele1970



SPECTRUMS OF
ARTISTS

- | | |
|---------|---------|
| 1 Live | 9 Eat |
| 2 Talk | 10 Live |
| 3 Eat | |
| 4 Drink | |
| 5 Work | |
| 6 Meet | |
| 7 Make | |
| 8 Dance | |

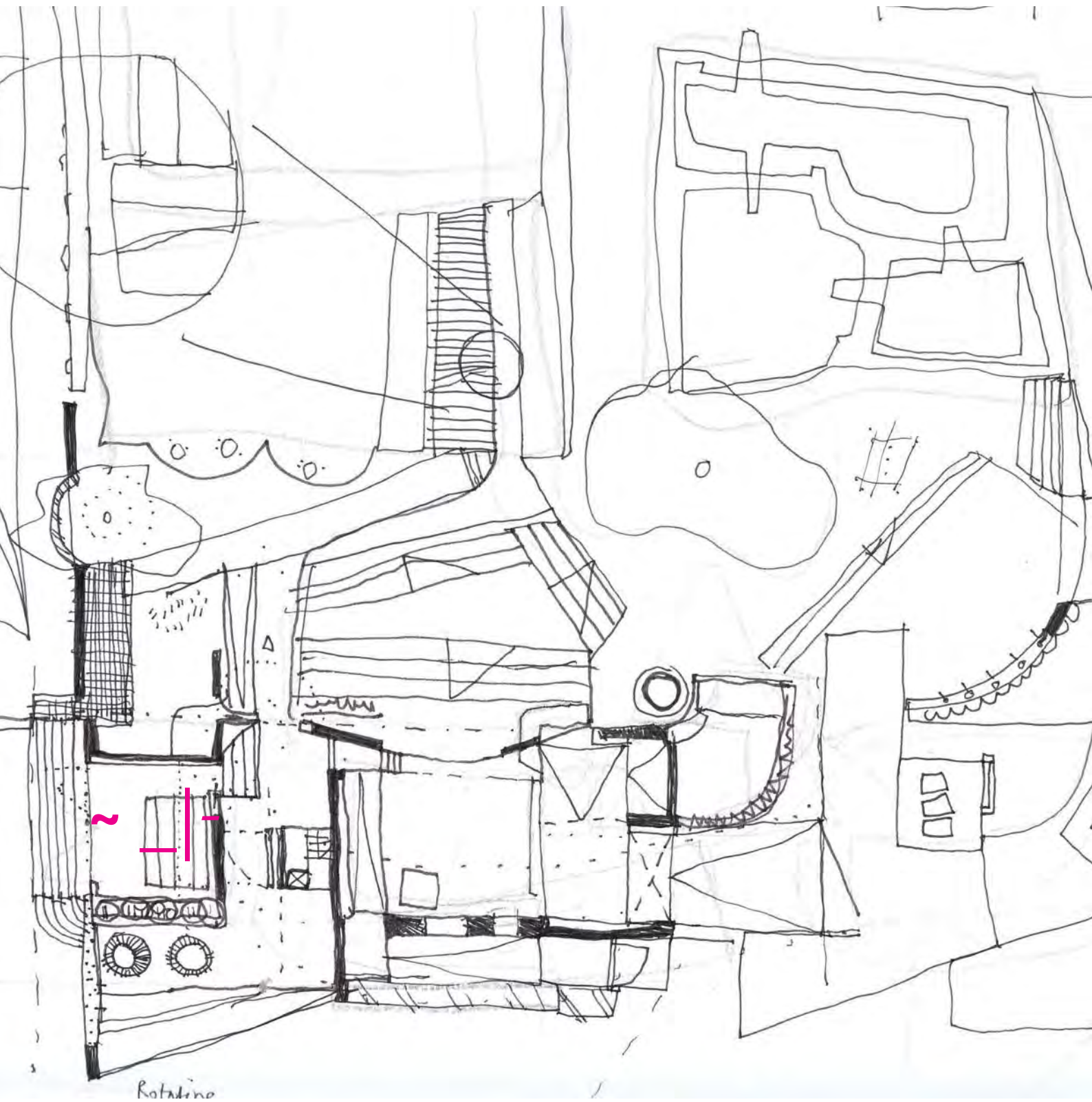

FIGURE 142 : Final sketch plan of the building - after removing the additional portal frame.

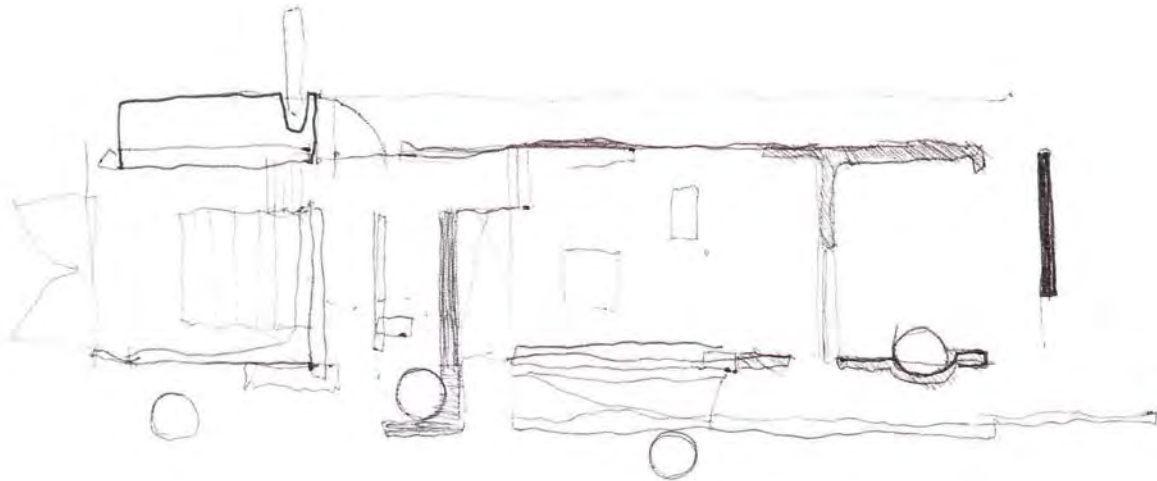
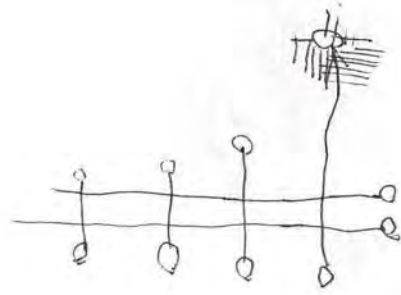
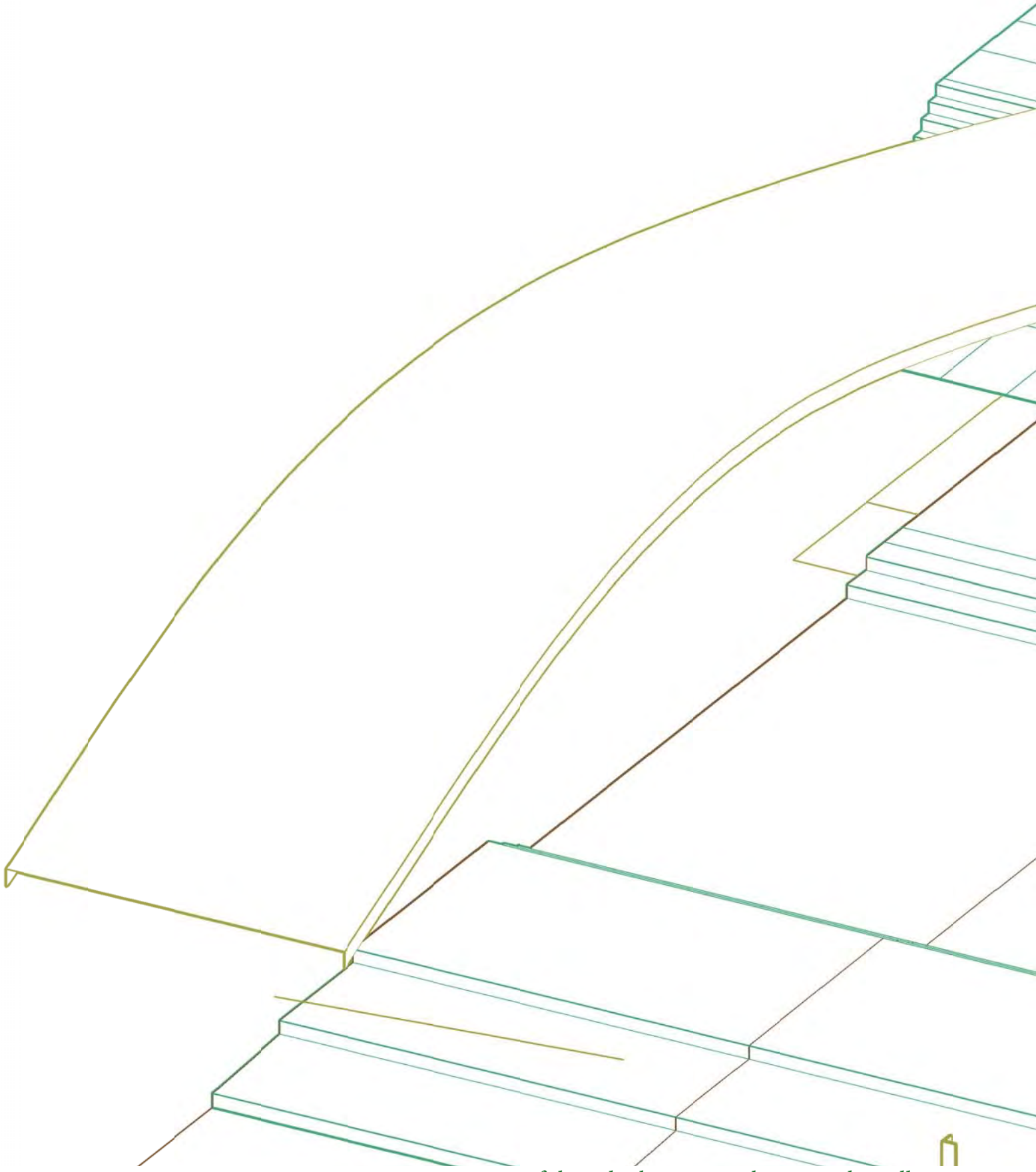

FIGURE 143 : Final partii diagram. sentence of symbols in relation plan spaces.



of the role theatre in relation to the gallery and the beacon structure in the foreground.

