



CHAPTER 5

DESIGN DEVELOPMENT

This chapter explores the spatial development of the site through the understanding of the overriding theoretical and conceptual intentions, the programmatic intentions and other design drivers.

- 5.1 THE CONCEPTUAL APPROACH
- 5.2 THE ARCHITECTURAL PRECEDENTS
- 5.3 THE PROGRAMMATIC INTENTIONS
- 5.4 THE SPATIAL EXPLORATION
- 5.5 THE DESIGN DEVELOPMENT
- 5.6 THE SKETCH PLAN EXPLORATION

5.1 THE CONCEPTUAL APPROACH

“Architecture is intimate with power. It requires authority, money, and ownership. To build is to exert power..”

“The question is how that power is realised - by whom, for whom, to whom.”

Rowan Moore (2012:169,197)

In the book *Why We Build* by Rowan Moore (2012) he speaks about spaces of power and spaces of freedom, and what elements constitute its volume. According to Moore, architecture is made up of the relationship between object and space. The object is the element of power. Its role is to provide shelter, protection and comfort and to cater to the happenings in and around the site.

On the other hand, Moore (2012:189) believes space encourages freedom. That space has the ability to be influenced by what occurs within it. It can be warm and intimate, or cold and uncaring. It can be free and accessible or closed-off and restricted. It is then job the of the architect to find the balance between these various elements of space and their characteristics.

Through our investigation of spatial justice we have immersed ourselves into the various types of space that make up the project site. The in-depth analysis allowed us to understand the value of the space, its strengths, its shortfalls and its justness. We find a direct correlation between Moores ideas of freedom and power, and Soja’s spaces of justice/injustice.

A space that has been classified unjust is a space that does not control its own power and freedom. The power lies in the hands of a prevailing authority, who can then misuse this power in order to dictate how that space can be used and who can use it. This then becomes a **space of oppression**.

In a space that can be considered just, the power manifested in that space lies in the hands of the occupying user. Therefore we find that the existing community then have the freedom to use and adapt the space according to their needs and future aspirations. This is a **space of empowerment**.

The architectural dissertation looks to use this understanding of space as a overriding principle in its approach to the design and development of space and architecture. In order for us to empower the community to become extraordinary, we need to empower the environment that they are situated in. Through this we can provide a platform that would encourage the growth and development of the community from this space of oppression and injustice, to one that is empowering and just.

SPATIAL DEVELOPMENT METHODOLOGY

In order to re-develop the site from one that is unjust and oppressive, to one that is empowering and spatially just we developed a spatial methodology as a guide to approaching the spaces of the site. The methodology looks to incrementally alleviate social injustices on the site through a series of spatial interventions that could lead to an **architecture of empowerment**.

After analysing the space and understanding its social and spatial intricacies that lead to it being spatially unjust, the process begins by opening up and exposing the oppressive space. Whether it is highlighting the oppressive spatial element in order to bring attention to it, or opening up a space that is enclosed, dark and dangerous.

The next phase looks at defining the spatial needs of the community. This investigates movement routes, daily rituals and important nodes on site that need to be made more accessible to the everyday pedestrian.

Once we have an understanding of what the community needs and what is important to them, we then can begin integrating these elements into the larger urban fabric of the site. Connections are made between private and public structures and a consideration for threshold and approach in the between building, street and pedestrian.

Lastly we develop programmes and functions for these spaces that relate to the communities needs as well as their future aspirations and growth. The spaces and adjoining programmes should be developed in such a way that allows the community to make use of and adapt these spaces over time as the community grows and their needs change. Through this process we can develop an architecture that empowers the everyday to become extraordinary.

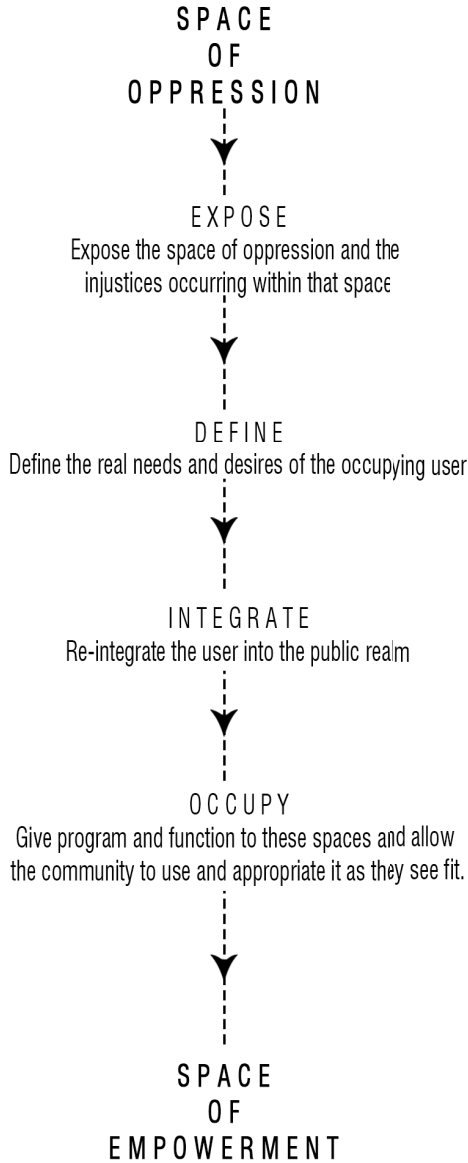

FIGURE 5.1 SPATIAL DEVELOPMENT CONCEPT

Diagram illustrating the various phases of spatial development that the site needs to move through in order to become spatially just and empowered

5.2 THE ARCHITECTURAL PRECEDENTS

Case study 1: MASP_LINA BO BAARDI



FIGURE 5.2 MASP
Photograph of MASP from the street looking towards the public plaza space



FIGURE 5.3 MASP
Photograph of MASP that shows the 3 spatial elements that constitute MASP

The Museum of Art in Sao Paulo (MASP) was design by the brazillian architect on a site that was once an important public belvedere (Moore 2012:160). The building consists of three main parts that together make up the whole. The basement section is a mass built into the slope of the site that contains a library, theatre, resturant and civic hall space (figure 5.6). Above it, on street level is the public plaza, which is defined by the concrete and glass box that is suspended in the air above it (figure 5.4). The glass box is in actual fact the main gallery space. The public space below it is completely open and can be used at any time for functions or event. Currently the space is being used to hold markets and concerts, as well as a gathering space for public protest. However, when it is not being used for events it is dark, unsafe and often used as a shelter for the homeless.

The masses of the structure is used to serve and define the void, thereby giving power to that void (figure 5.5). The mass above it charges the space below it and gives it significance. It is not an architecture that looks to be iconic and powerful, but rather one that seeks to use its presence in the urban landscape to enrich the existing, and provide a space that allows many possibilites and encourages the communities frrdom to take ownership of that space.



FIGURE 5.4 VOID AND STREET
Photograph illustrating the relationship between structure and street

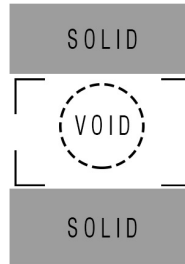

FIGURE 5.5 SPATIAL CONFIGURATION
Diagram illustrating the relationship between mass and void and how the masses empower the void

SOLID the gallery

VOID the public plaza

SOLID the civic facilities

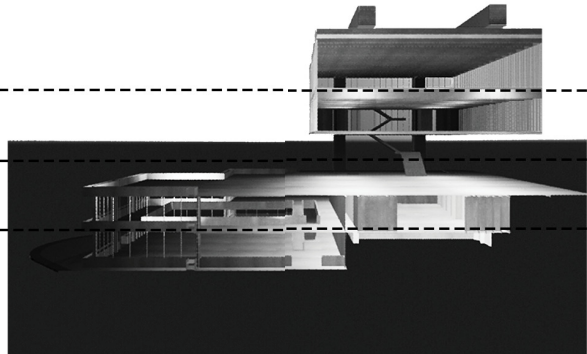

FIGURE 5.6 SECTION THROUGH MASP
3D section perspective of MASP illustrating the functions of each element

Case study 2:

KANCHANJUNGA APARTMENTS_ CHARLES CORREA



FIGURE 5.7 KANCHANJUNGA APARTMENTS

Photograph of the punctured facade of the of the apartment block



FIGURE 5.8 LOGGIA

Photograph of the large double volume veranda space

The Indian architect, Charles Correa, was commissioned in 1970 to build a residential tower in the over-populated city of Bombay. The challenge that Charles was faced with was how to develop a residential living solution that is comfortable and liveable in a dense environment (Khan, Hassan-Uddin 1987:56). The other issue he faced was the environmental conditions in Bombay. In order to pick up on the prevailing winds and take advantage of sea-views, the building had to be orientated east-west. This unfortunately exposed the building to the harsh eastern and western sunlight (figure 5.9).

As a way of mediating this problem, he came up with an innovative living solution. The residential apartments are organised in an interlocking modular system that is wrapped around a central core (figure 5.10-11). On the outer skin he then placed a series of balconies and loggias that open up the residential building to its environment, but also act as a device to protect the internal living spaces from the harsh climate. The loggias also provide breathing spaces within the dense residential fabric that is often used for social gatherings and relaxation.

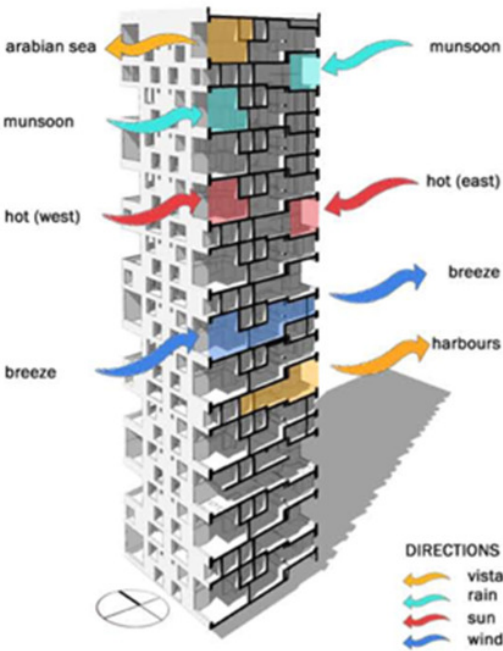

FIGURE 5.9 ENVIRONMENTAL CONSIDERATIONS
Diagram illustrating how the building responds to its environmental conditions

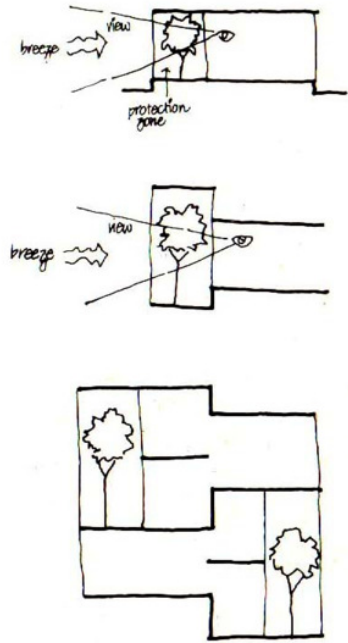

FIGURE 5.10 SPATIAL CONCEPT
Diagrams illustrating the interlocking unit concept and the loggia role in protecting from the elements, while allowing for views and collecting the breeze

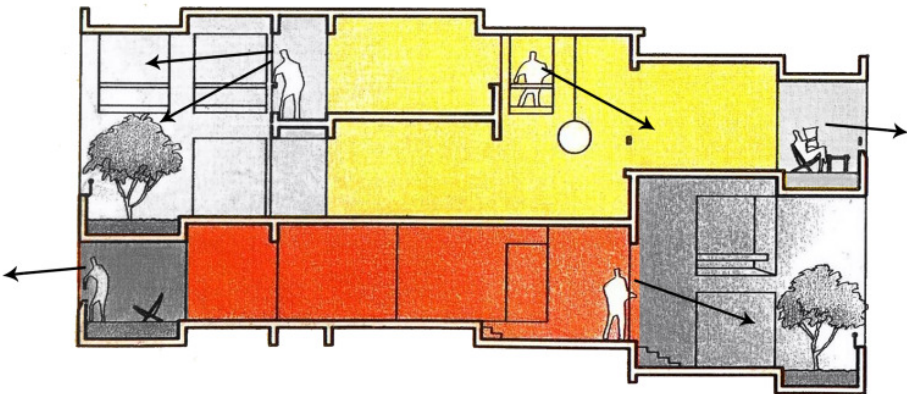

FIGURE 5.11 INTERLOCKING UNITS
Section illustrating how the residential units are interlocking and modular, with the large veranda spaces protecting the internal living space from the elements. We can also see how these veranda spaces open up and create transparency in the structure.

Case study 3: WITS ART MUSEUM _ COHEN & GARSON



FIGURE 5.12 WITS ART MUSEUM
Photograph of the new facade of the new re-furbished facade of the Wits Art Museum.



FIGURE 5.13 STREET EDGE
Photograph depicting the unified street edge open to the pedestrian

The Wits Art Museum (WAM), completed in 2011, holds the large art collection that is owned by the university. When inviting architects to compete for the commission, WITS stipulated that the new design should look at existing structures around the university and develop a strategy for adaptive re-use (Paul Kotze 2014). The final site was chosen on the corner of Jorriksen St, and was made up of three very different structure, one that was a petrol station and car garage. The university also stipulated that this new facility would be the “face” of wits outside of the university walls, with the intention of connecting with the surrounding community and making it accessible to the everyday pedestrian. For that reason the building needed to have a presence in the public realm and contribute effectively to street life.

The intervention successfully manages to unify and integrate the 3 various structures on street level with an additional screen layered in-front of the facade that defines the entrance and welcomes the pedestrian. A restaurant and open gallery space on the street edge encourages interaction between the street and the gallery which begins to activate the street edge.



FIGURE 5.14 EXISTING STREET EDGE CONDITION
Photograph depicting the existing building and its closed off street edge and delapidated condition.



FIGURE 5.15 NEW DEFINED STREET EDGE
Photograph depicting the new layer attached to the facade used to define the street edge



FIGURE 5.16 THRESHOLD
Photograph depicting the various layers of approach moving from public to the semi-public internal space

5.3 THE PROGRAMMATIC INTENTIONS

PROGRAMME DRIVERS

The main programmatic drivers for the dissertation project is the overriding theoretical and conceptual approach which looks at spatial justice and architectures of empowerment.

In the spatial justice analysis we identified social and spatial programmatic gaps on the project site that has lead to the condition of liminality that the existing community experience today. Being stuck in this condition stunts their growth and their ability to succeed financially in the precinct.

While many of the issues of spatial claim and spatial linkage can be solved through a series of subtle spatial interventions, spatial power which looks at the ability of a person to succeed in his community and contribute back to it, requires a lot more thought and attention.

From our investigation we found that the project site lacked the resources and opportunities necessary to assist the community in the development of their respective businesses. We noted the various forms of trade present on site, and that they were mostly survivalist in nature. Through the re-arrangement and re-development of space, these facilities could be greatly improved. However, without the necessary knowledge and skills, these businesses would still struggle to transcend their survivalist nature and allow for opportunity and growth. This requires additional support structures to be put in place that could provide the resources knowledge and training necessary for the development of small businesses.

The primary programmatic function of the architectural intervention is **a small business development centre** that integrates holistically with the existing city fabric.

The centre responds to all three sectors of spatial justice. With regards to spatial claim and the ability to “live” in the city, the centre provides mixed-use facilities that consist of dynamic living, working and playing spaces. The primary function of this centre is to assist traders in the area with the development of their businesses in order to help them succeed in the precinct, and contribute back to its community, this is a characteristic of spatial power. Lastly, the centre responds to the ideas of spatial linkage by creating a space where various entrepreneurs, academic and educators in and around Johannesburg can connect and develop relationships that could be beneficial to the community of Joubert park. These type of relationships help break down the social barriers restricting the precinct.



FIGURE 5.17 SURVIVALIST TRADE

Photographs from the precinct showing the character and nature of the economic opportunities available on site.

PROGRAMMATIC INTENTIONS

It is the projects intention to integrate the small business development centre into the existing fabric on the project site. In order to accomplish this wee need to re-examine the existing programs on site, and re-structure them accordingly to allow for this new intervention.

There are three phases to this programmatic development:

1. The first phase involves the re-development and re-structuring of trade in the precinct, which begins to strengthen the existing trade networks on site, in order to prepare them for the additional economic infrastructure that is to be inserted. This phase of the development will be undertaken by the owners of the mall in order in conjunction with the city of Johannesburg, in order to optimise their profits in their location.
2. The second phase looks at the re-development and refurbishment of the residential tower on site, and its relationship to the new retail node. In order for the small business development centre to be integrated and assist the existing community, there is a need to first act upon the issues that they experience daily in their living environment. In this way, once the centre is introduced into this context, it would be more easily welcomed and appreciated, as their basic spatial needs would have been met. The residential development would be undertaken by the owners of the building in conjunction with housing developers in the inner city such as EKhaya neighbourhood development. This would be prompted by the development of the retail sector on side it, in order to create a more successful cohesive environment, and profit from the renewed success on the site.
3. The third phase lastly looks at the implementation of the small business development centre on to the site. This centre would connect physically to the exiting structures in order to feed off its energy as well as to make a direct contribution to both retail and residential sectors. This phase would be developed by the city of Johannesburg who look to empower small business in the area, and would be run and managed by an NGO on behalf of the city.

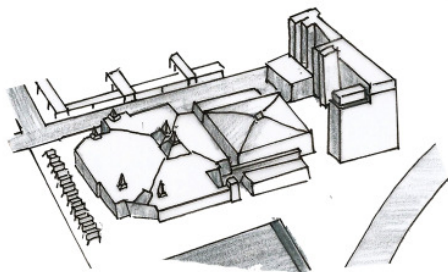

FIGURE 5.20 EXISTING SITE
3D diagram of existing project site

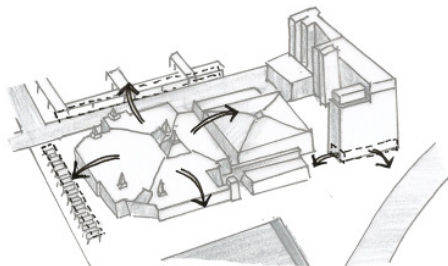

FIGURE 5.21 PHASE 1
The re-structuring of the retail sector to be more accessible to the pedestrian and to integrate into urban fabric

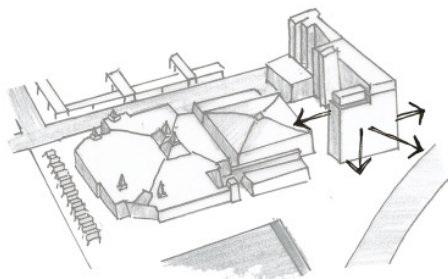

FIGURE 5.22 PHASE 2
Renovation of residential structure in order to expose and integrate it into the urban environment

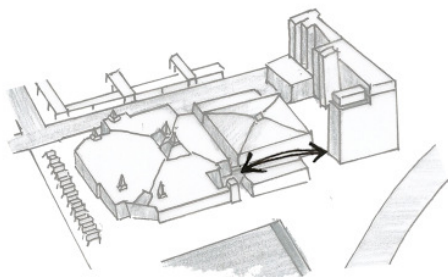

FIGURE 5.23 PHASE 3
The integration of the retail and residential fabric through the implementation of the small business development centre

5.4 THE SPATIAL EXPLORATION

5.4.1 THE DEVELOPMENT OF THE BLOCK

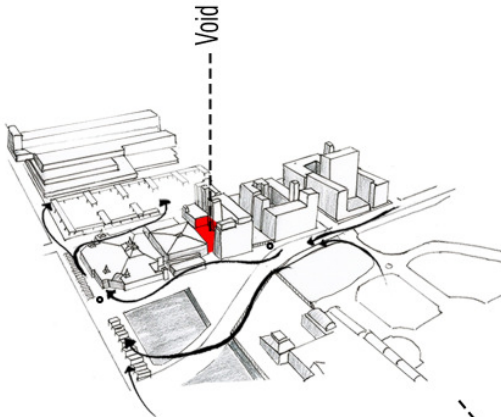

FIGURE 5.24 SPACE OF OPPRESSION
The existing condition

The first point of approach looks at the void between the retail and residential structures. From our analysis we've seen that this space is dark and enclosed, and therefore dangerous in the city context.

Using the conceptual methodology discussed we look to re-develop the space from one that is unjust/ oppressive to one that is considered spatially just and empowering.

The spatial development begins at a larger scale that looks at the entire block of the project site, creating a mini framework within which the new intervention will fit. Once the larger site has been envisioned, we will focus on more specific elements on site such as the trade and the living spaces. Once the existing site has been re-developed to function and perform optimally, we will then begin investigating the spatial opportunities for design intervention.

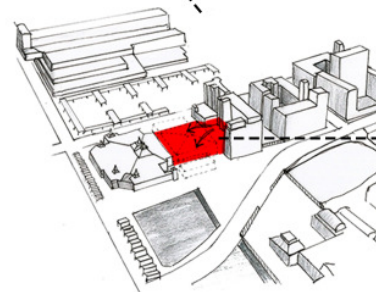

FIGURE 5.25 EXPOSE
Revealing the void

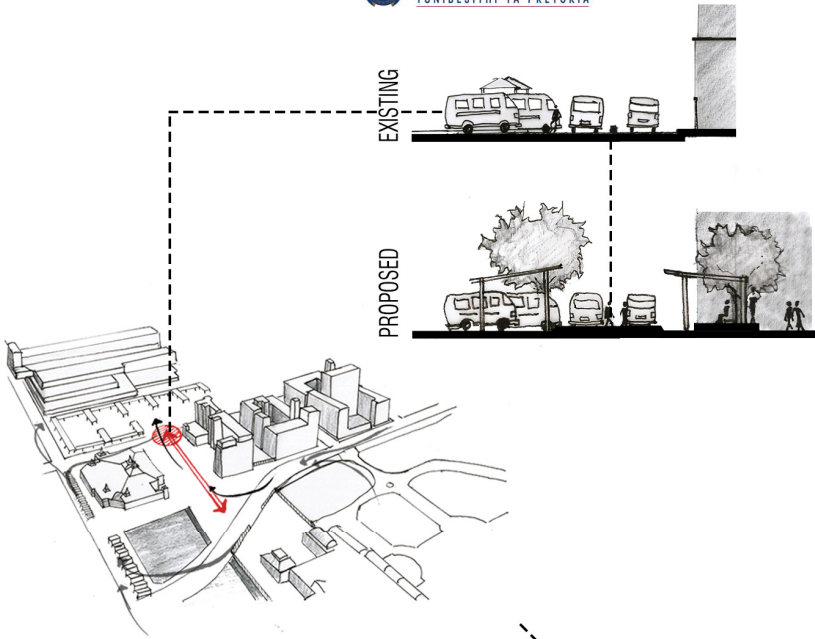

FIGURE 5.25 DEFINE
Defining the new movement route through the site

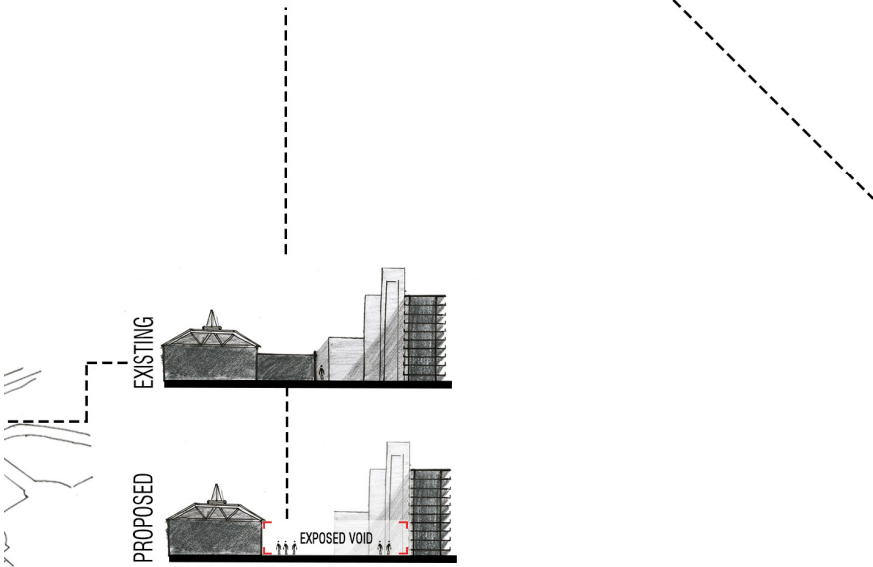



FIGURE 5.26 INTEGRATE
Connecting important nodes on site

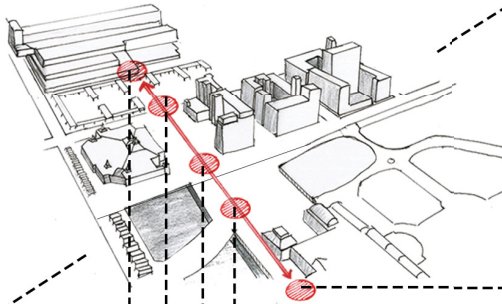
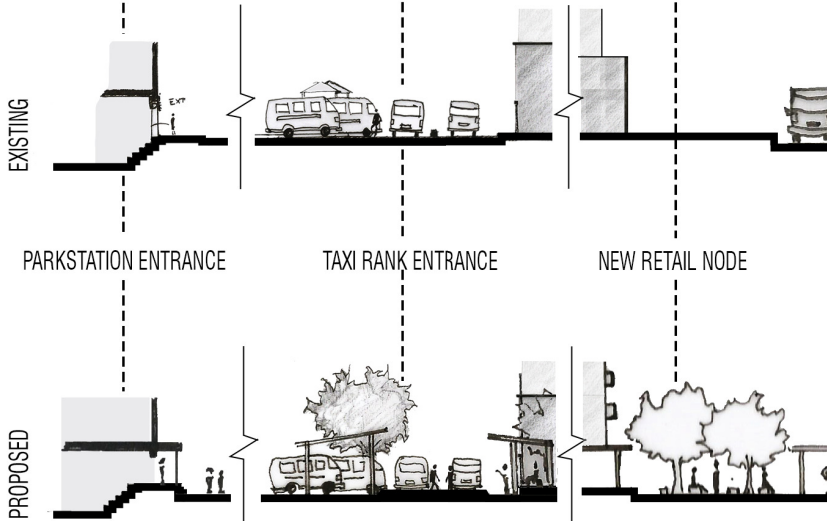
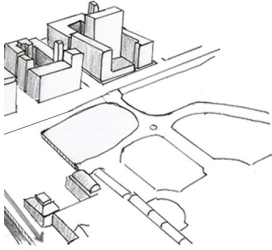
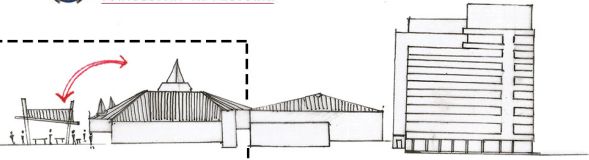

FIGURE 5.27 O.C.
Relocate the linear ma





EXISTING



PROPOSAL

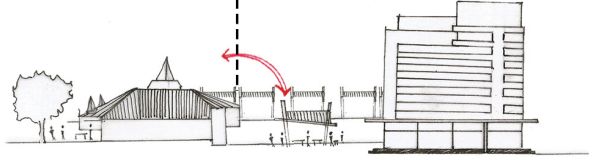

Y
the space to give it function

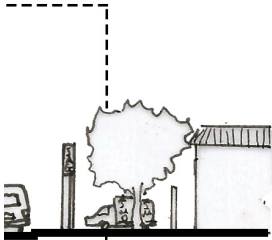

JAG SITE ENTRANCE

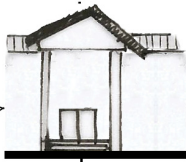

JAG PEDESTRIAN ENTRANCE

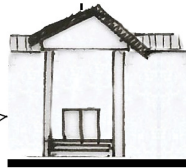
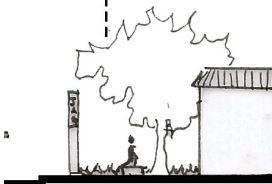

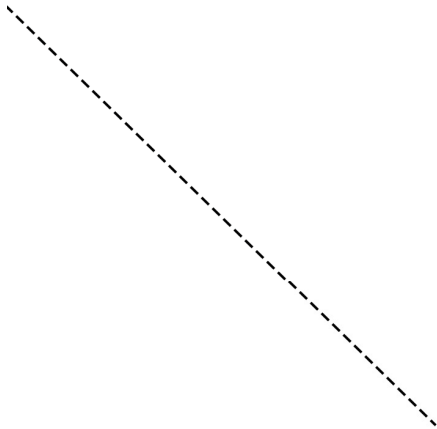
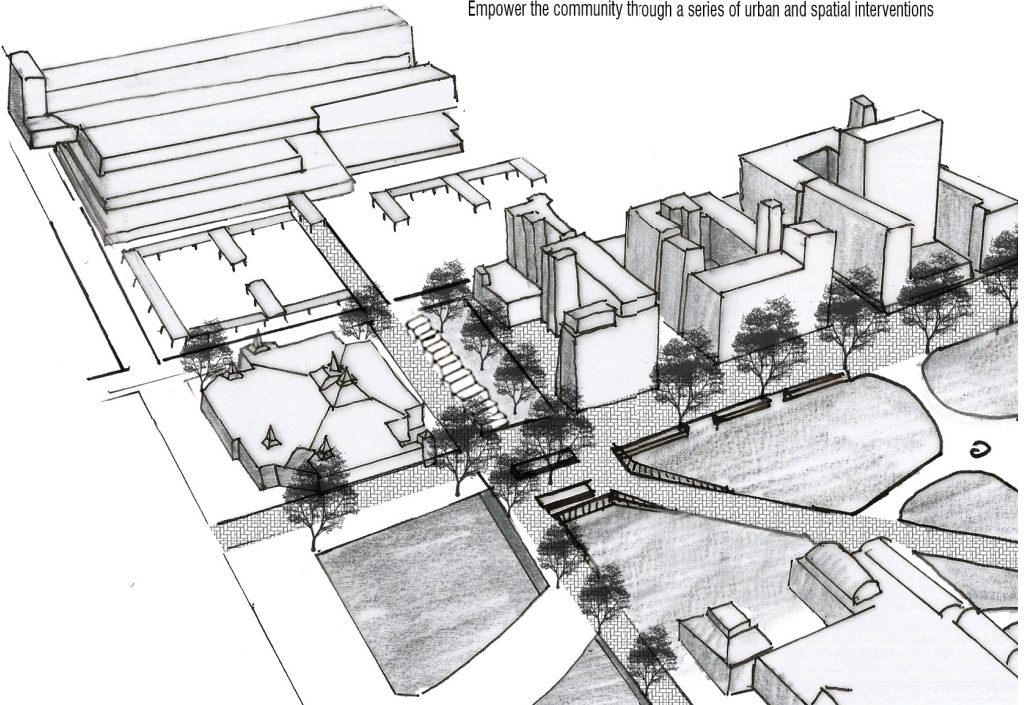

FIGURE 5.28 EMPOWER

Empower the community through a series of urban and spatial interventions



PHASES OF SITE DEVELOPMENT

Expose

The enclosed void is opened up and exposed, liberating the space and allowing light into the courtyard area. This also looks to expose and bring light to the illegal activities and threats that occupy the space currently.

Define

Through an understanding of the movement on site a new route is defined that would better cater to the needs of the community. This new route opens up access to the taxi rank.

Integrate

The route is then extended to begin to integrate important nodes along it. It begins at the new proposed entrance to Park Station and connects through the site to JAG. This reinforces and builds upon the existing east-west axis on site which now further includes accessibility to the park, the gallery and the transport infrastructures through this courtyard space.

Occupy

The courtyard is then given life and energy by relocating the linear market from the southern edge of the mall to the defined void space. The market which served the original movement to and from park station would continue its function, while being better integrated into the built fabric and responding better to the needs of the community.

Empower

The larger site now integrates the transport/ retail/residential and recreational fabric in and around the project site, spatial linkage issues identified in chapter 4. This will act as a foundation from which the project's urban vision develops and will directly influence the next phase of the development of the trade and residential sectors on site.

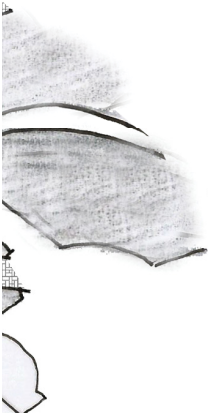

5.4.2 THE DEVELOPMENT OF SPECIFIC SITE COMPONENTS

A - DEVELOPMENT OF TRADE

FORMAL RETAIL _ THE BRIDGE MALL

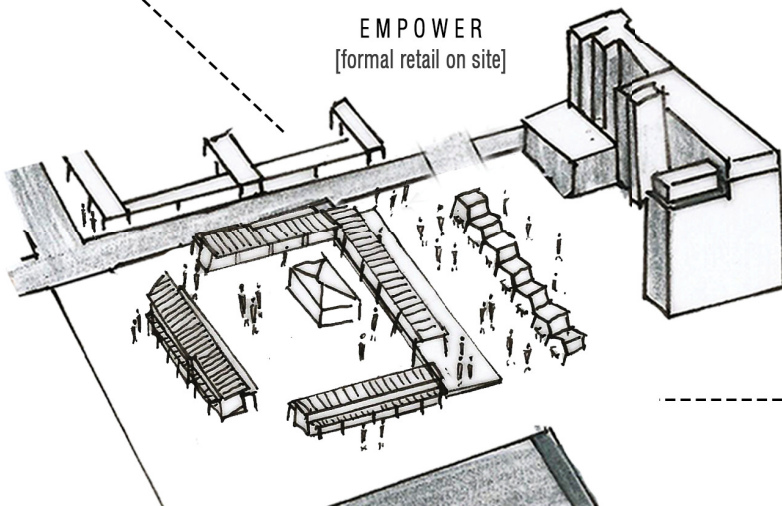
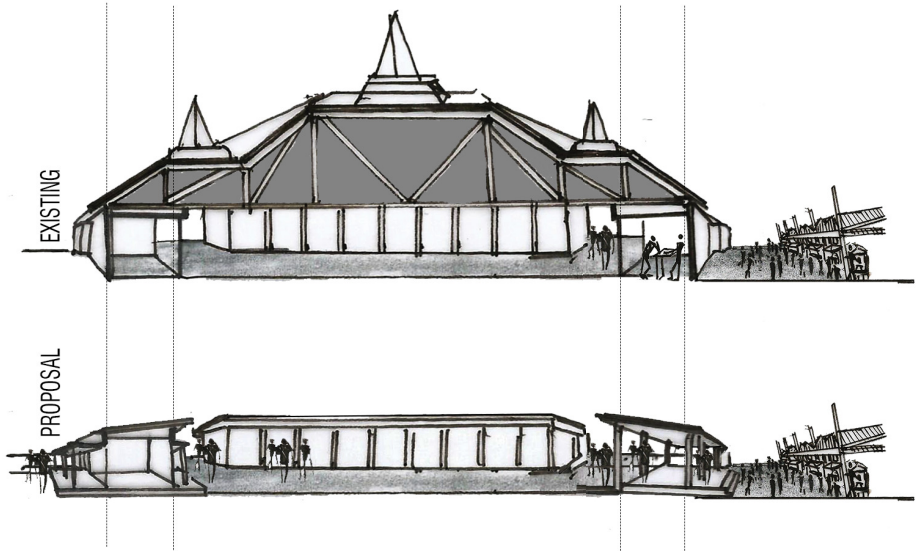

EXISTING

Mass acts as barrier in the landscape, trade is disconnected from public realm and inaccessible

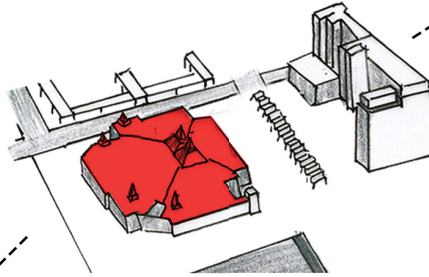

EXPOSE

Make retail accessible by removing the roof and exposing internal structure and function

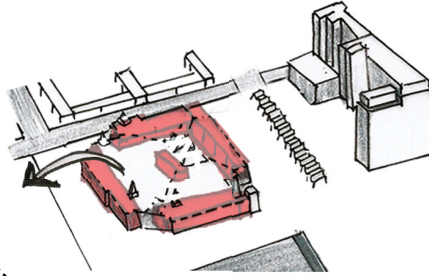

DEFINE

Diagonal movement through site coming from the CBD moving towards the park begins to puncture the mass

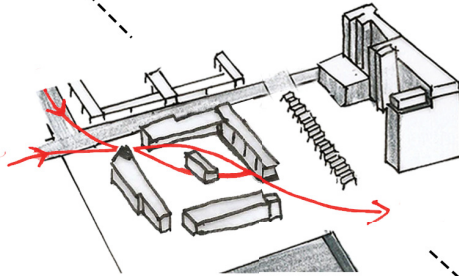

INTEGRATE AND OCCUPY

Trade is introduced to both sides of its structure to open it up to the pedestrian movement on site.

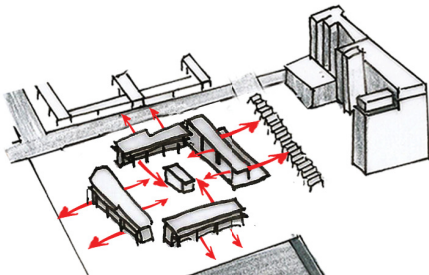



A - DEVELOPMENT OF TRADE

FORMAL RETAIL _ RESIDENTIAL RETAIL EDGE



EXISTING

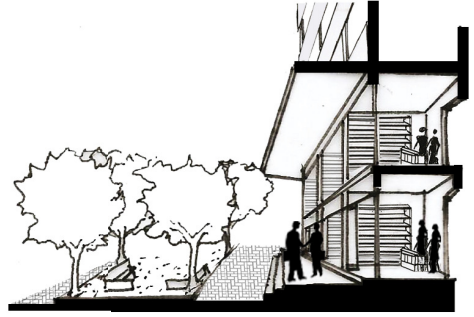

PROPOSAL

EMPOWER
[the retail edge]

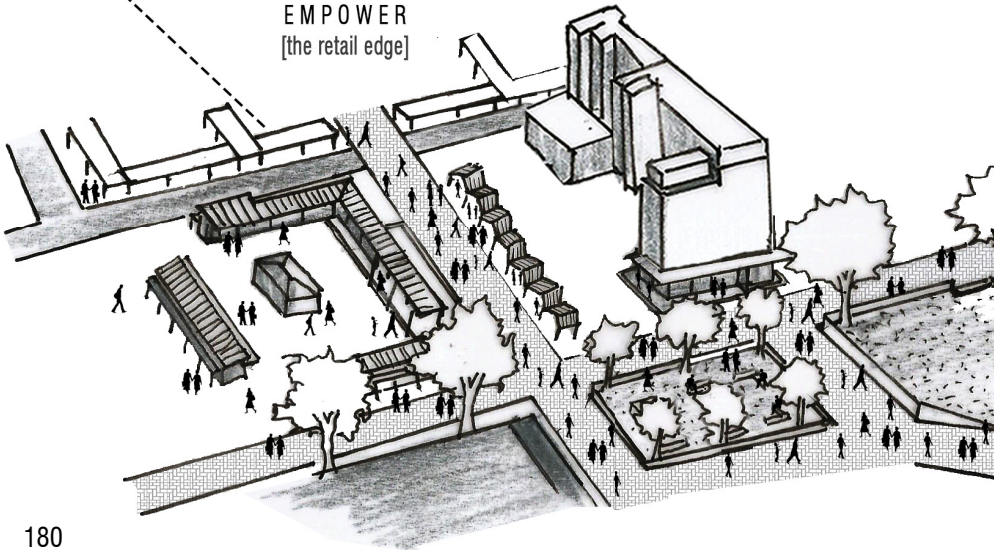



EXISTING

Trade on the residential edge is undefined and disconnected from public realm

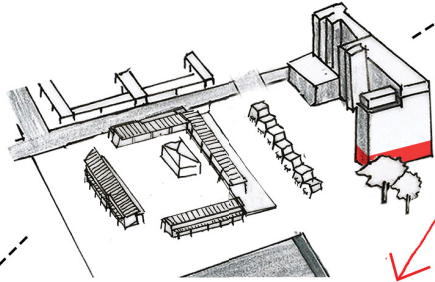

EXPOSE AND DEFINE

Expose retail edge to the pedestrian by defining its edges, and by creating a series of thresholds that pick up the pedestrian from the main movement route

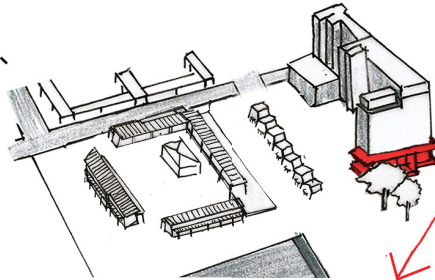

-----INTEGRATE AND OCCUPY

Integrate edge into the public realm by populating and giving function to the vast pavement space separating it from the street edge.

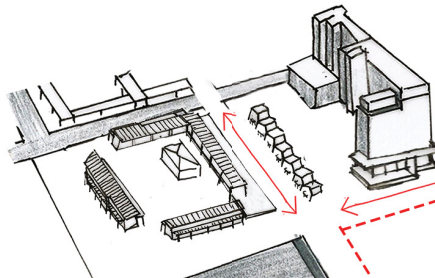

A - DEVELOPMENT OF TRADE

INFORMAL TRADE _ LINEAR MARKET

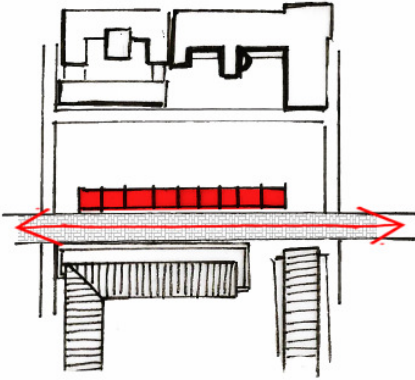

EXISTING

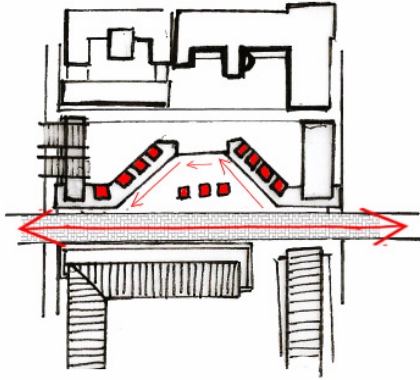

PROPOSAL

EMPOWER
[the informal trade]

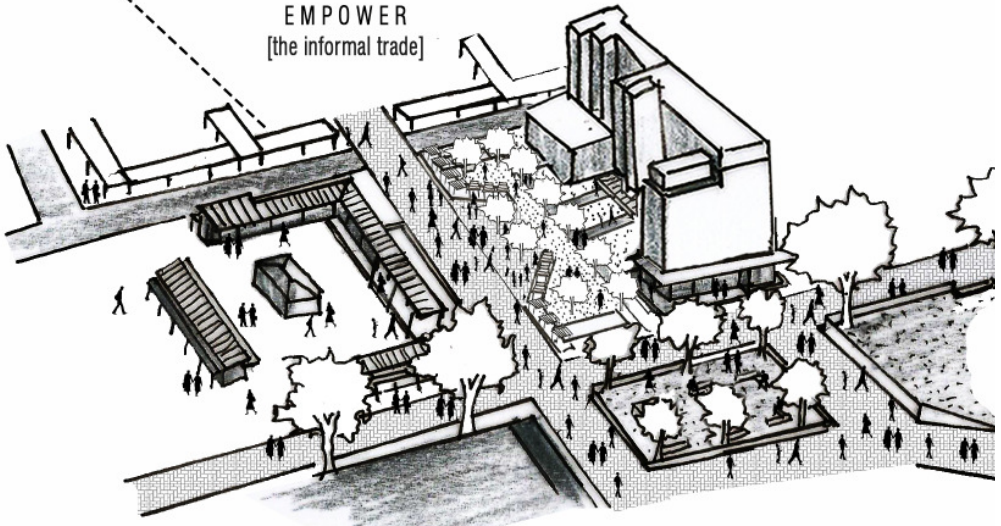

EXISTING

Trade site directly on the edge of main movement route there is no threshold or layers of approach between the two, making for an uncomfortable shopping/browsing environment.

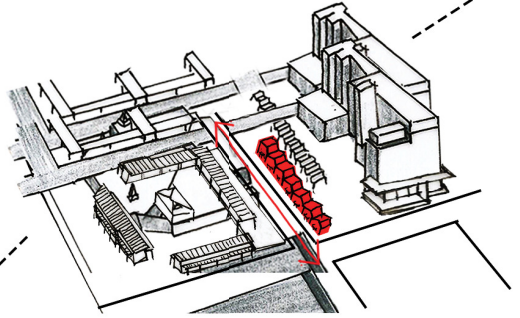

EXPOSE AND DEFINE

Create breathing space between fast paced pedestrian movement and market by recessing it into the square to allow for a secondary line of movement that's slower and allows the customer to dwell.

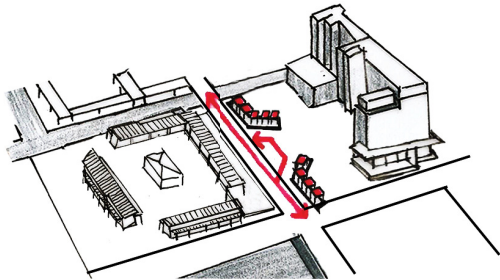

INTEGRATE AND OCCUPY

Integrate the edges of the market into the public spaces alongside them with a platform for events that open up onto the park square and a bus stop on the opposite end to react to the entrance of the taxi rank

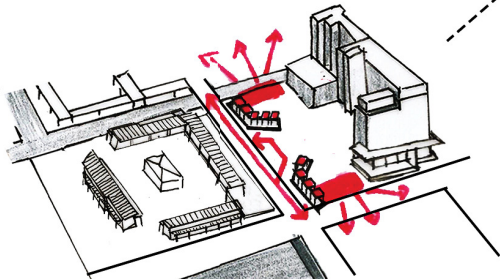

B - DEVELOPMENT OF RESIDENTIAL TOWER INTERNAL LIVING SPACES



EXISTING MULTI USE LIVING SPACES

The redevelopment and renovations to the existing residential building on site takes into consideration how space is currently being utilised and adapted to suit the needs of its existing occupants.

We find examples of how a single bedroom is converted into a mini-flat with spaces to work/ clean/ wash/ and cook all squeezed into the small bedroom space.

In our vision for the building we look to create 2 storey live-work units, which can be compartmentalised in order to rent to a sub-letter opened up to create a larger living space.

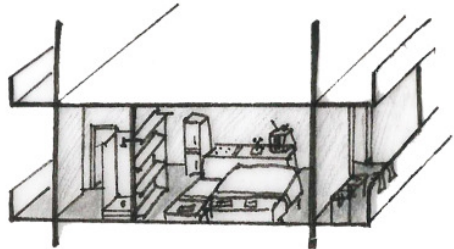

EXISTING

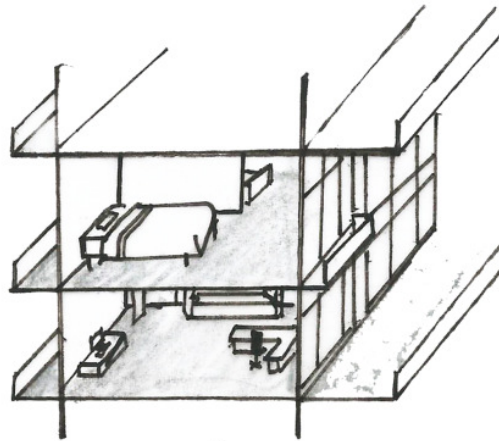

PROPOSAL

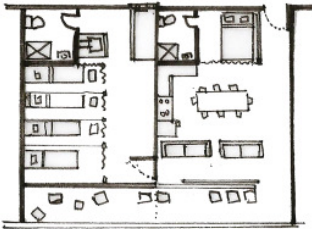

EXISTING COMMUNAL LIVING SPACES

We also find example of creative living solutions for different types of occupants. Communal living arrangements have been organised in order to cater to the dense living environment which allows occupants to share resources.

One flat would be used for eating and socialising and storage, while the other flat caters to sleeping and cleaning. The two flats together create a dynamic living environment.

We look to build upon this train of thought by creating communal living spaces, with cooking and socialising spaces on the first floor and sleeping and private spaces on the second. In this way we're building upon this communal culture that has been established, but creating better living conditions and environments that aren't overly populated, but rather that allow for growth.

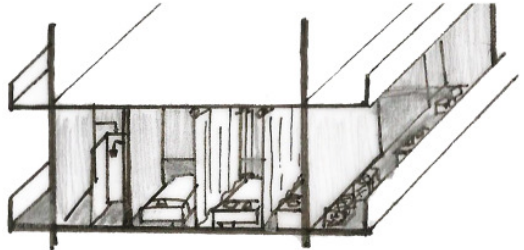

EXISTING

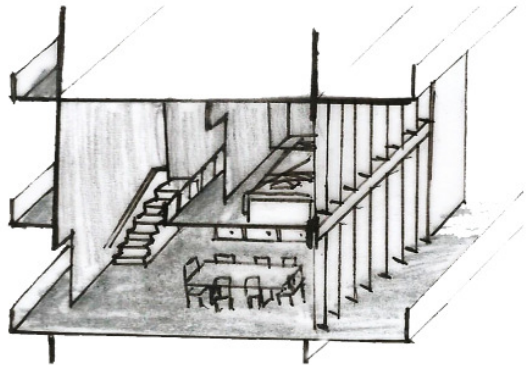

PROPOSAL

B - DEVELOPMENT OF RESIDENTIAL TOWER INTERNAL SOCIAL SPACES

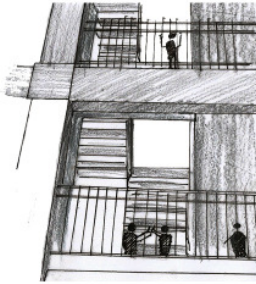

SOCIAL CIRCULATION SPACE

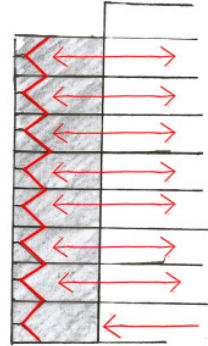

EXISTING

The circulation space in the existing residential building is a space that belongs to all the occupants and connects all the dwellings, this has made it an ideal space for social interaction. Throughout the day we find children running through its corridors and down its fire escapes.

The project looks to incorporate these ideas into the renovation and development of the residential fabric. By giving more space to the circulation, opening it up to allow in light and creating an environment for social interaction.

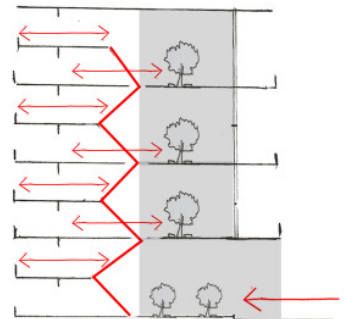

PROPOSAL

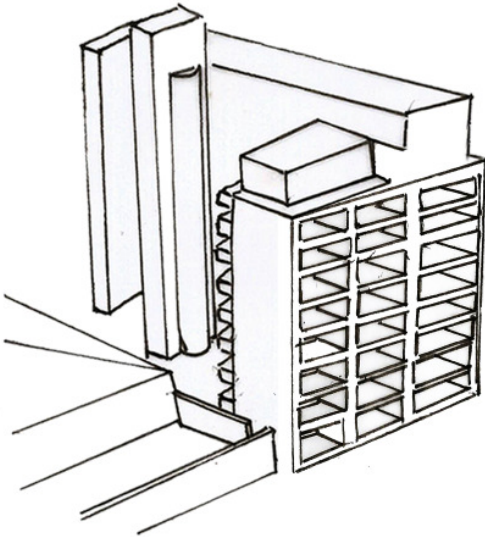

EXISTING

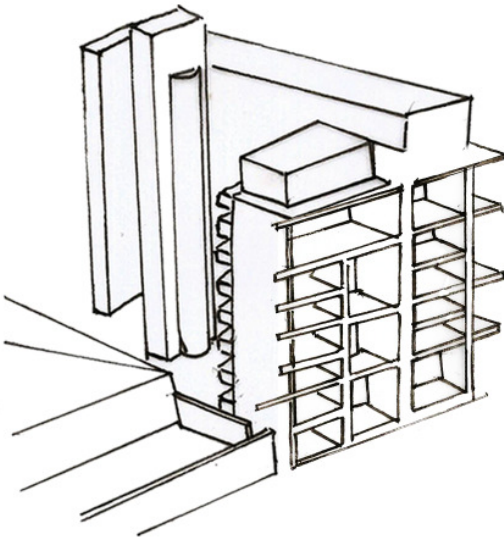

PROPOSAL



CONSOLIDATED SPATIAL VISION THE URBAN FRAME

EMPOWER
[the city block]

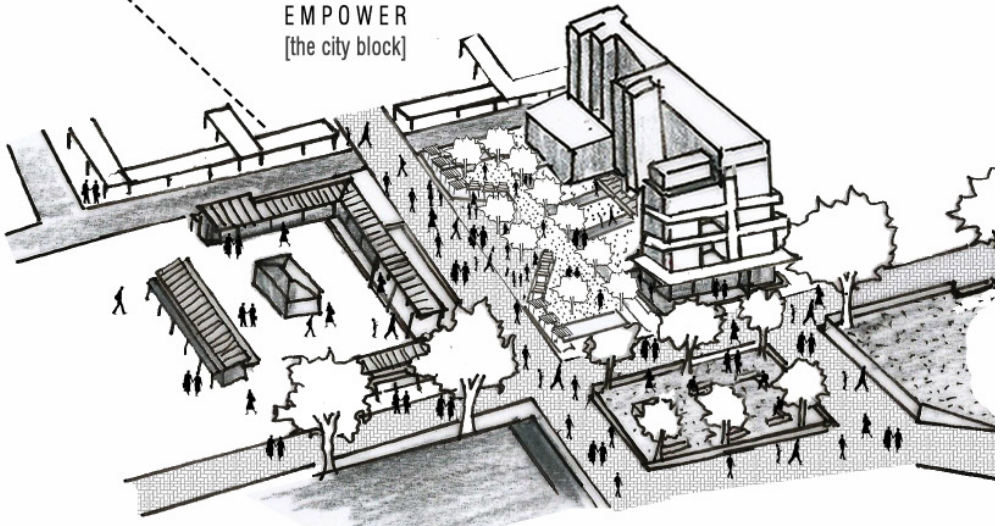

The new model of the city block speaks of accessibility, permeability, and spatial definition. It refers back to Lina Bo Bardi's concept of the solids that serve the void. On the project site the public square created between the residential and retail structures holds more importance in the context of the larger community than the buildings themselves. We've created an urban frame in which life exists and is empowered.

This space acts as an introductory threshold space into the park. It looks to slow down movement coming from the high energy transport sector, to the recreational park. We envisioned the park to be a space that can be experienced and wherein one can dwell. This square in the urban fabric intends to be the element that introduces people into the park space and adjusts their pace and intentions in order to better appreciate this developed park precinct and all it has to offer.

The small business development centre looks to situate itself into the fabric of this envisioned city block. It looks to integrate with the existing fabric and continue the theme of framing urban life. The project looks to further define the threshold between Park Station and the park, and create a series of layers of approach that slowly move the pedestrian from a high energy, de-personalized spatial experience, to one that is calmer and encourages interaction and thought.

In the next section we look at the design intentions of the architectural intervention, its iterations and programmatic layout of the spaces in relation to the site context.

C - DEVELOPMENT OF THE NEW BUILDING

FORM STUDIES

The new model of the city block speaks of accessibility, permeability, and spatial definition. It refers back to Lina Bo Bardi's concept of the solids that serve the void. On the project site the public square created between the residential and retail structures holds more importance in the context of the larger community than the buildings themselves. We've created an urban frame in which life exists and is empowered.

This space acts as an introductory threshold space into the park. It looks to slow down movement coming from the high energy transport sector, to the recreational park. We envisioned the park to be a space that can be experienced and where one can dwell. This square in the urban fabric intends to be the element that introduces people into the park space and adjusts their pace and intentions in order to better appreciate this developed park precinct and all it has to offer.

The small business development centre situates itself into the fabric of this envisioned city block. It looks to integrate with the existing fabric and continue the theme of framing urban life. The project looks to further define the threshold between Park Station and the park, and create a series of layers of approach that slowly move the pedestrian from a high energy, de-personalized spatial experience, to one that is calmer and encourages interaction and thought.

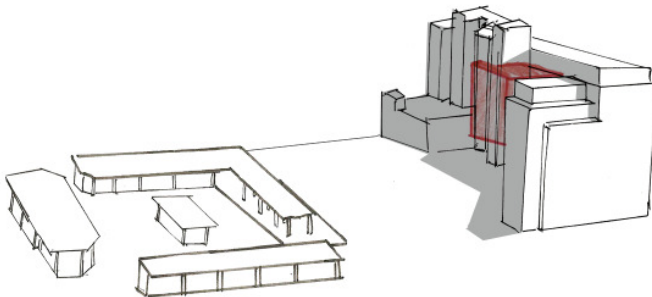

FIGURE 5.36 MASSING STUDY 1

Attaching to the southern facade of the residential tower over-looking the courtyard space. Intervention has no direct access to northern light.

From the beginning of the design process, the architectural intervention looked to attach to the existing fabric physically, in order to react to their programs and spatial qualities. The initial intention was to connect to the residential building and provide an extension over the courtyard (figure 5.36). Through sketch plan and section investigations we found that any attachment to the southern facade of the structure would not receive any daylight and fall within the shadow of the 10 storey residential tower. This would be a rather unpleasant social and interaction space.

The second approach at massing considered the integration of both the residential and retail sectors, where the intervention would act as a mediator between the two, however there was a spatial disconnect in the scale of the two structures. The mall is maximum two storeys in height, while the residential towers surrounding it are all between 10 and 20 stories. This led to the up-scaling of the retail facility that would help it relate better to the scale of the inner city. The ground floor would still remain predominantly retail, with the newly developed eastern edge would house the formal economic spaces necessary for the small business development centre. The intervention then sits between these two masses, forming a bridge-like architecture that creates a threshold in the urban landscaping moving between the transport precinct to the park precinct.

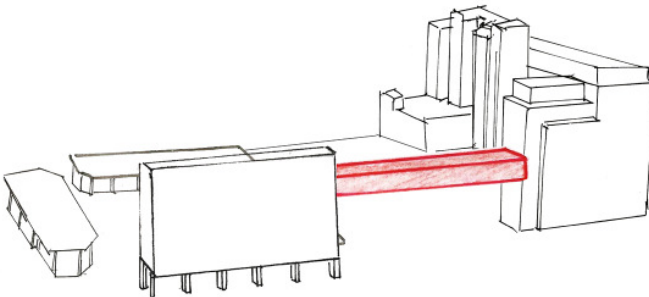

FIGURE 5.38 MASSING STUDY 2 (PHASE 2)

The architectural intervention attaches to both the residential structure and the retail/economic facility

C - DEVELOPMENT OF THE NEW BUILDING FORM STUDIES

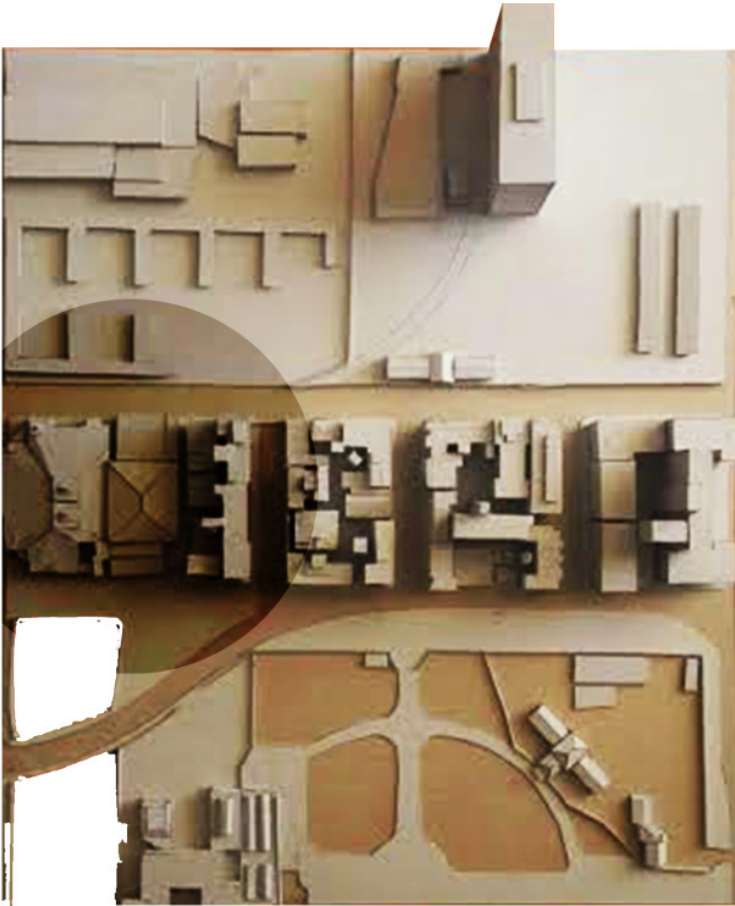

FIGURE 5.39 EXISTING SITE MODEL

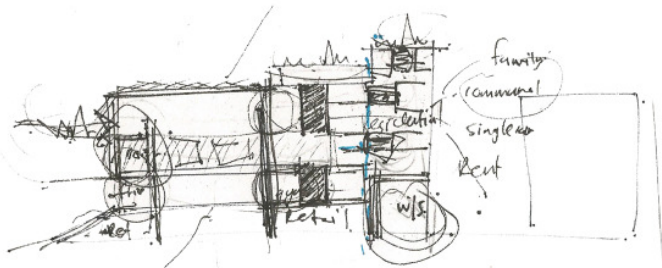

FIGURE 5.40 CONCEPTUAL DEVELOPMENT SKETCH

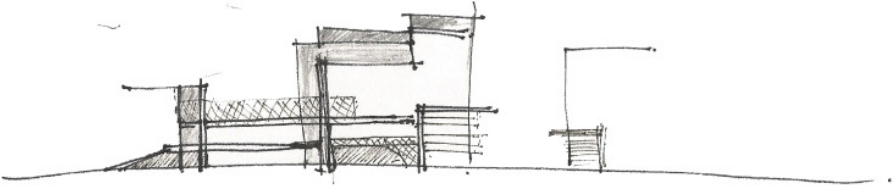

FIGURE 5.41 CONCEPTUAL DEVELOPMENT SKETCH



FIGURE 5.42 MARQUETTE OF BRIDGE INTERVENTION



FIGURE 5.43 MARQUETTE OF OF LARGER SITE

C - DEVELOPMENT OF THE NEW BUILDING

SPATIAL DEVELOPMENT

The concept of the “bridge building” was then further explored to determine its spatial possibilities. The initial massing in figure 5.38 was static and performed more as a bridge than as a building. This inspired further exploration that sought a more dynamic spatial system.

We began to play with the concepts of mass and void that has been a continuous thread throughout the investigation, and looking how we continue to use the masses as a means to define and empower the void. Figure 5.44 illustrates the spatial intention of the intervention, where the programmatic functions were exploded into separate masses which served the encompassing void, defined by the larger deck structure.

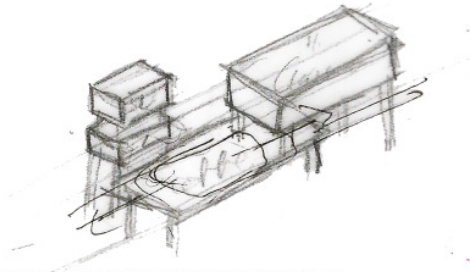

FIGURE 5.44 SPATIAL INTENTIONS OF THE INTERVENTION

The language of the architectural insert responds to the existing with regards to its spatial order and grid layout, as well as to the linear balcony elements of the existing residential building. It distinguishes itself from the art deco tower by contrasting in its materiality. The heavier elements of the brick and concrete is contrasted by the light weight steel structure and cladding that attaches to it. Clearly distinguishing between what is existing and what is new.

This concept continued to evolve through the application of programmatic necessities and more practical considerations, such as movement and services in the building. Essentially the small business development centre was divided into three sectors (figure 5.45), the joining element would act as the educational centre with the necessary resources needed for learning and interaction. The residential building provides communal and temporary living spaces for students/academics of this centre and the retail edge serves as the economic and development centre.



FIGURE 5.45 SPATIAL INTENTIONS OF THE INTERVENTION

These three sections are inter-connected through a series of connecting walkways that wrap around the major structure connecting to the two main circulation cores in the primary structures (figure 5.46).

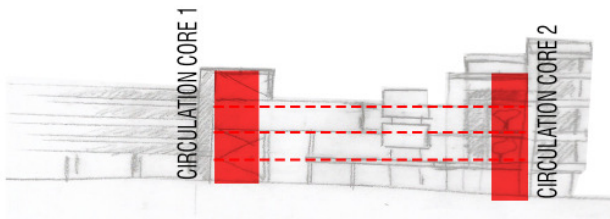

FIGURE 5.46 INTER-CONNECTING WALKWAYS

The project looks to integrate with the existing programs on site in order to create a model of what a hybrid typology city block can look like in Johannesburg. It intends to illustrate how existing functions can become part of a holistic system that seek to include and empower the existing community, instead of isolate and displace them.

C - DEVELOPMENT OF THE NEW BUILDING

PROGRAMMATIC DEVELOPMENT

In chapter 3 we identified and analysed the various forms of trade on site and in chapter 4 we explored their social and spatial composition in order to understand their underlying complexities and potential opportunities.

Both the formal and informal trade on site is survivalist in nature and requires additional support and resources to be able to develop into businesses that has the ability to expand. The small business development centre looks to explore the economic opportunists of the trade on the site and provide additional platforms for their growth.

The process begins by professional volunteers examining each business and looking at ways in which it can expand in the format of a basic workshop and discussion (phase 1). This discussion will revolve around the concept of the business, its business plan and its future aspirations.

Once it has reached a satisfactory level of conceptual development, the product goes through a design and development process (phase 2) with the assistance of design students and professionals in the required design field (product, graphic, architectural design etc.).

In the next phase prototypes are created and tested (phase 3), in workshop spaces provided with the necessary equipment and resources. This prototype is then tested in the market through temporary pop-up retail spaces on site.

If the product is found to be successful it continues into the economic and marketing phase that assists entrepreneurs with financing options and marketing strategies for their business (phase 4), and looks at possibilities of integrating these businesses into the retail sector of the Joubert Park precinct.

Each phase of development consists of an educational counterpart that provides the necessary information, skills and training that the community needs in order for them to find their footing, and to empower themselves and the people around them through the knowledge and support that they acquire.

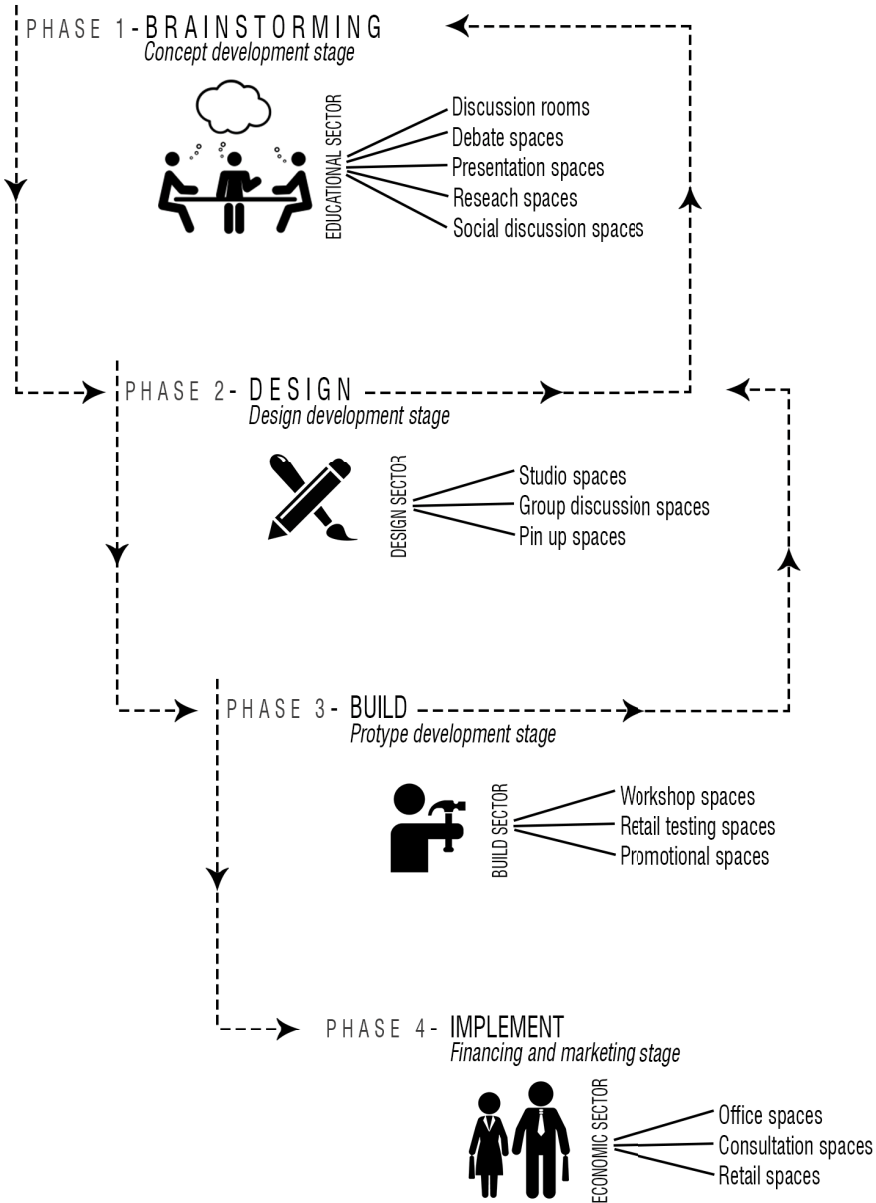

FIGURE 5.18 MODEL FOR THE DEVELOPMENT OF TRADE

Programme map of the small business development centre in each of its required sectors and the spatial requirements of each sector



C - DEVELOPMENT OF THE NEW BUILDING

PROGRAMMATIC DEVELOPMENT

RESOURCE LIGHTBOX

Resource centre and presentation room

FORMAL LEARNING SPACES

Classroom spaces

SOCIAL LEARNING DECK

Adaptable partitions to define social learning spaces

ENTERTAINMENT DECK

Coffee bar and social spill out space for both residential and educational sectors

EDUCATIONAL CENTRE

Learning and social spaces

RESIDENTIAL TOWER

Communal living units, live-work units and larger family units

RETAIL CENTRE

Re-developed mall space

ECONOMIC CENTRE

Workshop, studio and consultant spaces

URBAN COURTYARD SPACE

Market and social space

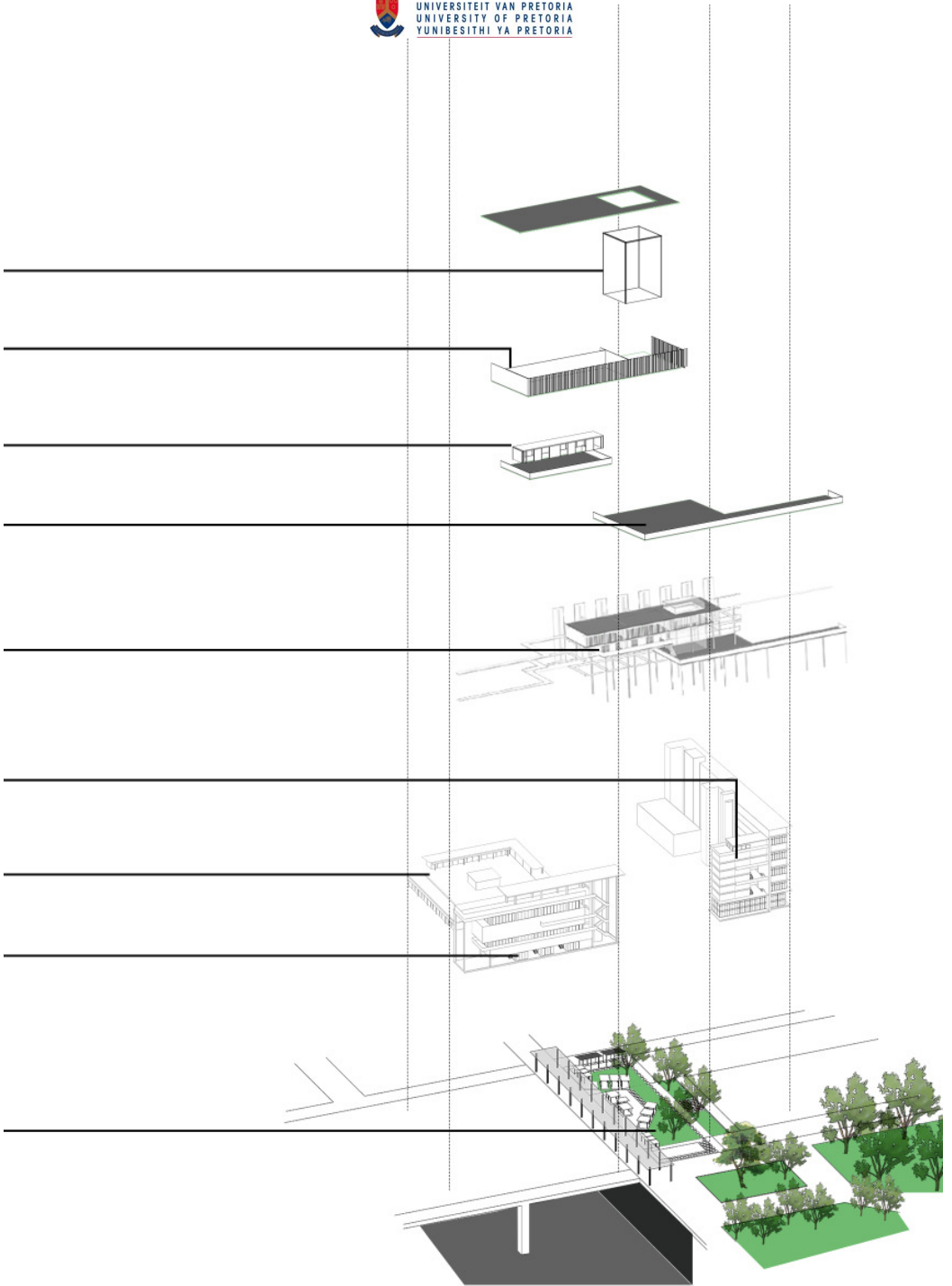



5.5 THE SKETCH PLAN DEVELOPMENT

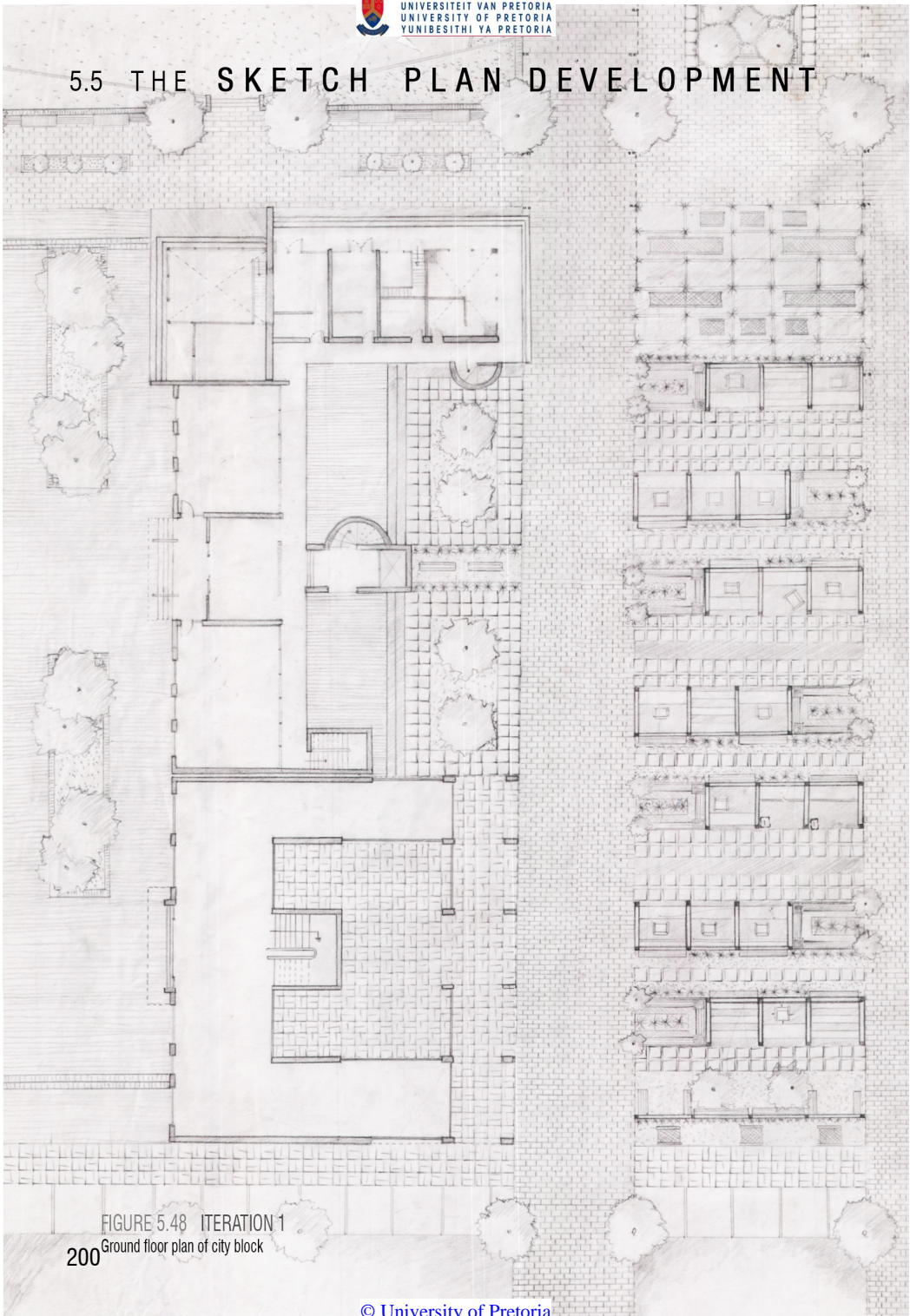
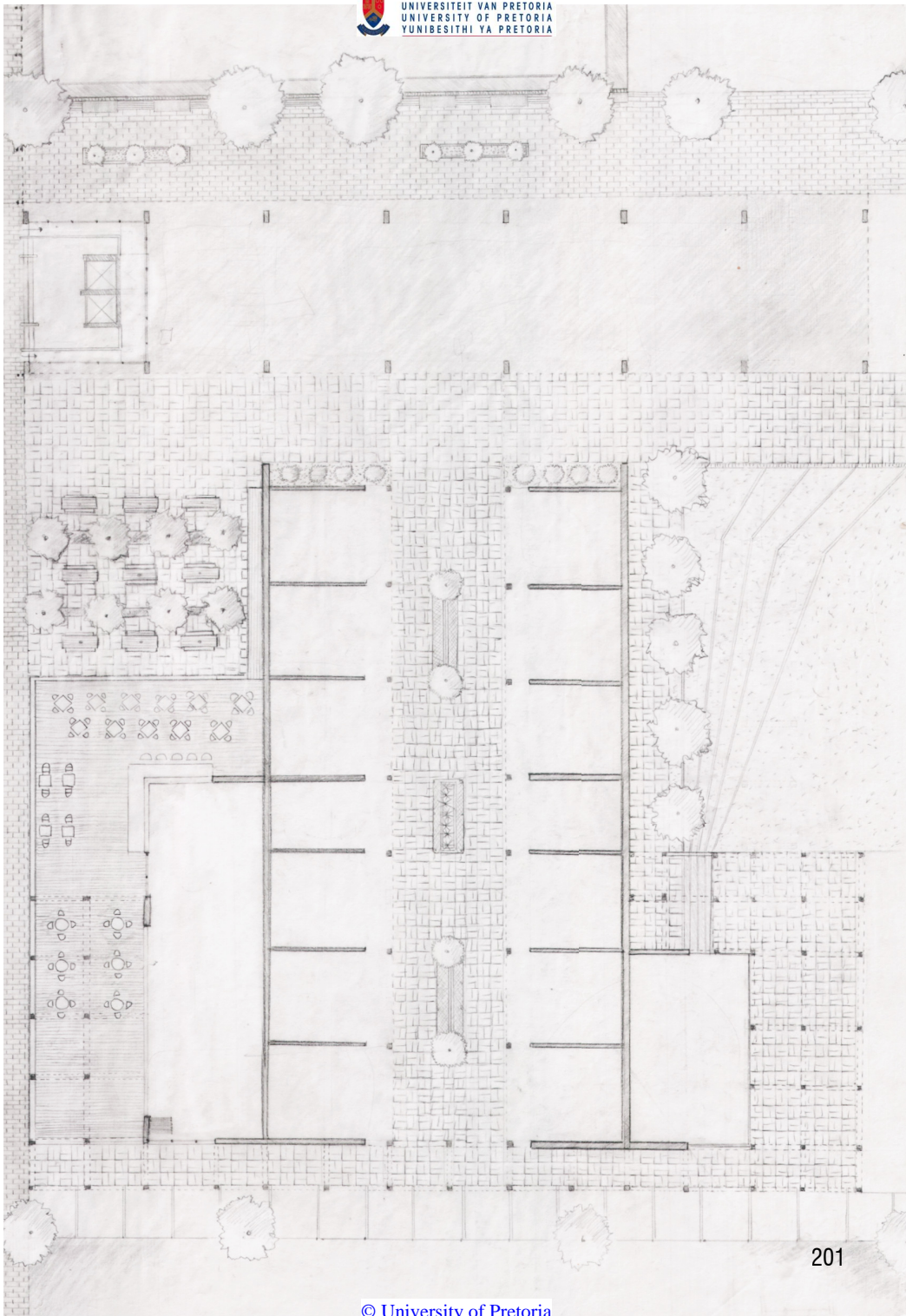

FIGURE 5.48 ITERATION 1

200 Ground floor plan of city block



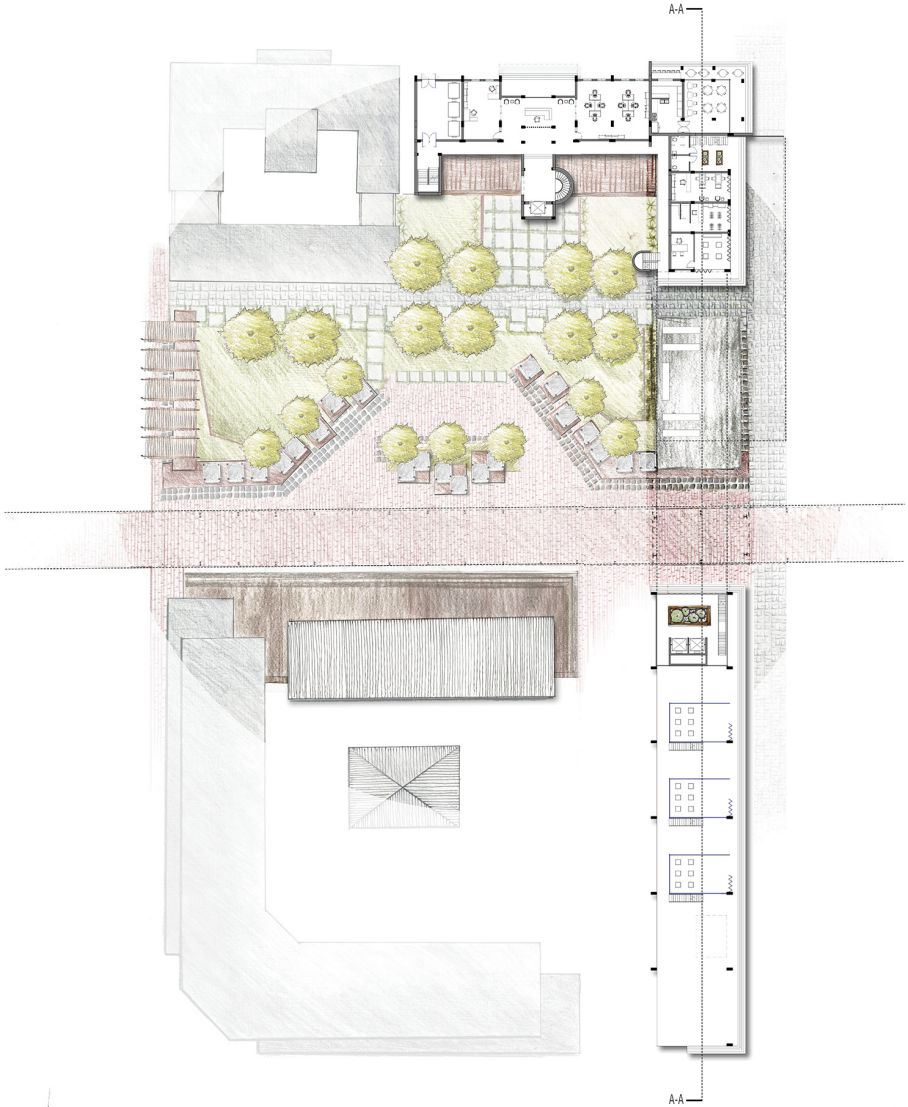

FIGURE 5.49 GROUND FLOOR PLAN

202 Ground floor plan of site highlighting the central courtyard space

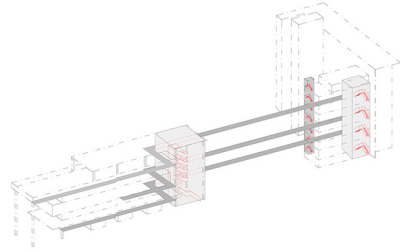
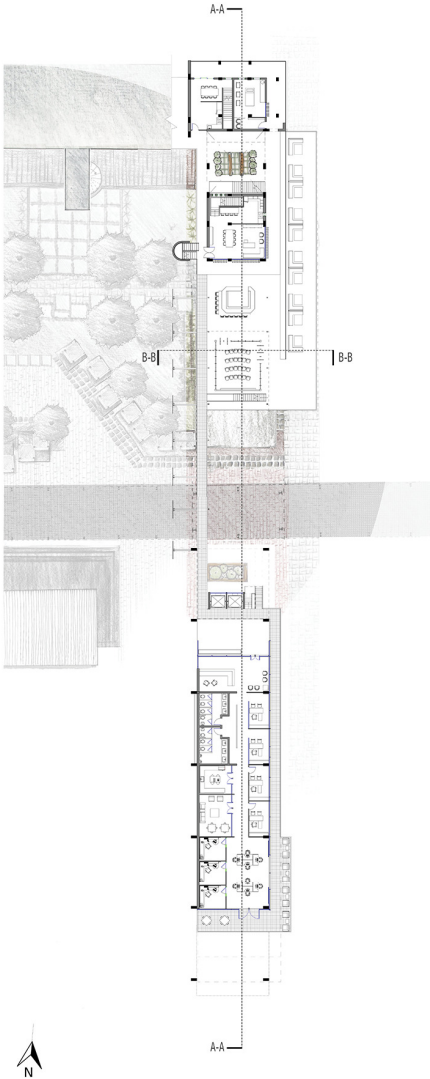

FIGURE 5.51 CIRCULATION
3D diagram indicating walkways and circulation cores

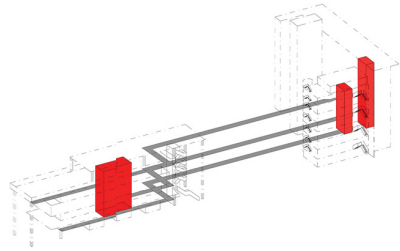

FIGURE 5.52 SERVICES
3D diagram indicating the location of the services cores in the building

FIGURE 5.50 THIRDS FLOOR PLAN
The base level of the bridge structure, indicating the large deck.

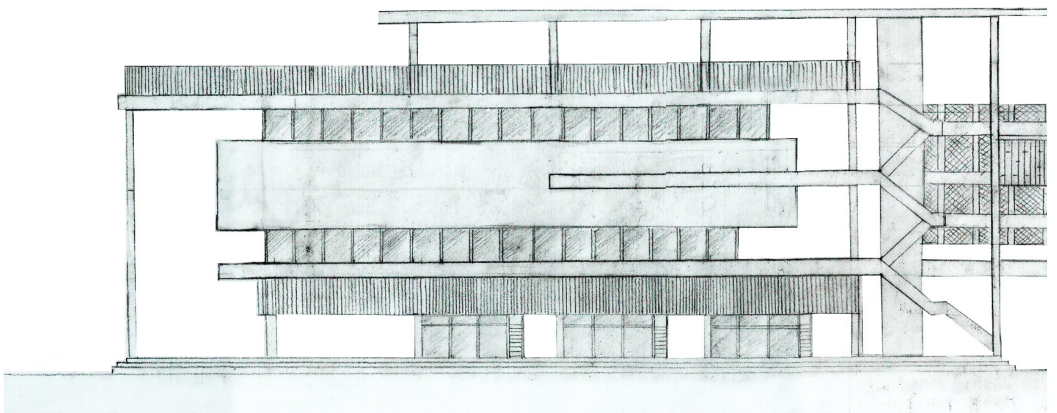

FIGURE 5.53 ELEVATION
Eastern elevation of the building

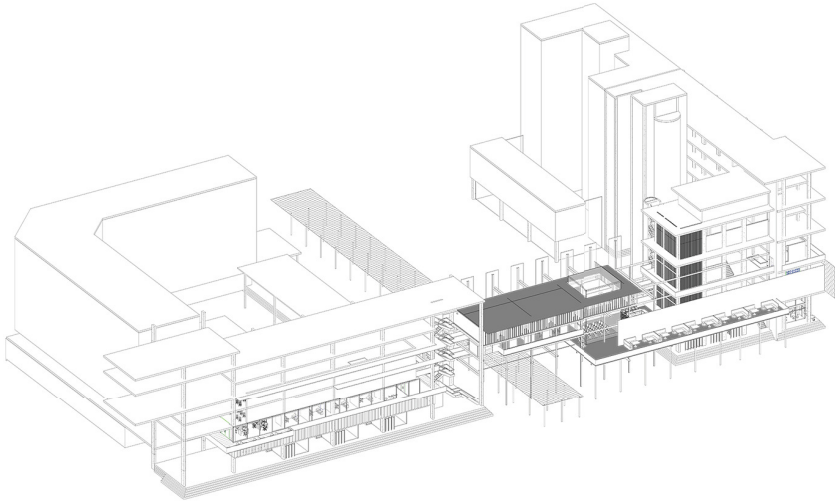
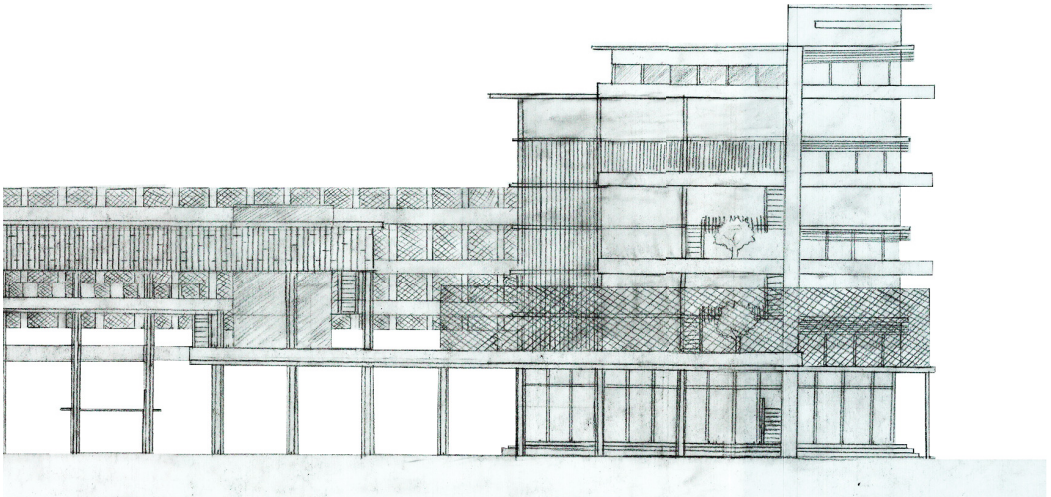

FIGURE 5.54 3D MODEL
3D model of the city block



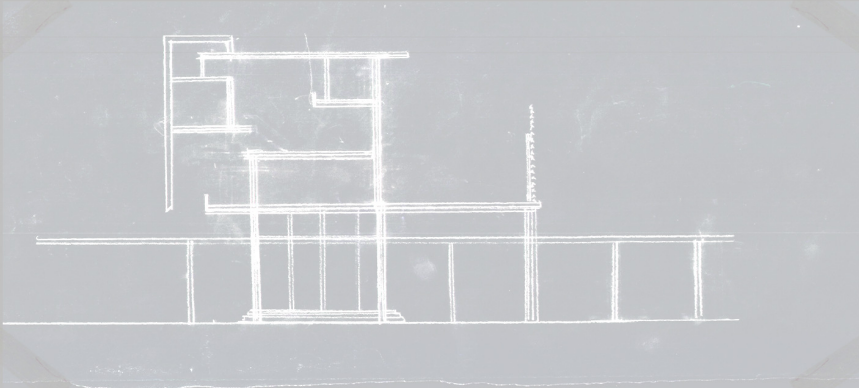

FIGURE 5.55 CROSS SECTION EXPLORATION

FIGURE 5.57 LONG SECTION THROUGH EASTERN FACADE



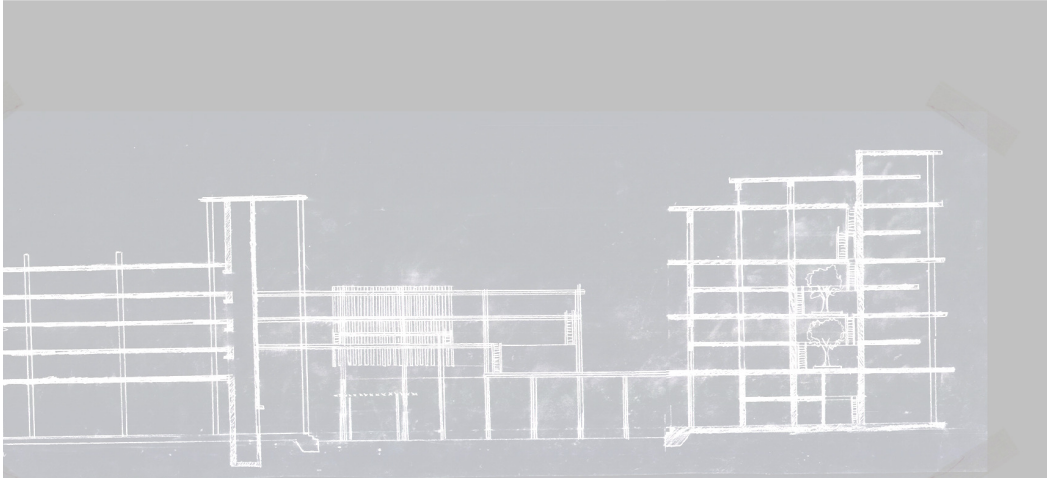

FIGURE 5.56 LONG SECTION EXPLOARTAIION

