

CHAPTER 4

SPATIAL JUSTICE: THEORY AND APPLICATION

This chapter begins by exploring the concept of spatial justice. It then uses it as a tool to analyse space.

- 4.1 THE THEORETICAL DISCOURSE
- 4.2 FROM THEORY TO METHODOLOGY
- 4.3 THE THEORETICAL ANALYSIS:
 - 4.3.1 THE SOCIAL FABRIC ANALYSIS
 - 4.3.2 THE SPATIAL FABRIC ANALYSIS
- 4.4 THE OUTCOMES

4.1 THE THEORETICAL DISCOURSE

“Space is a place of intersecting struggles/oppression/opportunities. How we move or not move through it, adapt to it, monitor it, buy or borrow it, claim or cut it off shapes everything we do and big parts of who we are.”

Makani Themba (2011)

Across the South African political landscape, the relationship between space and social injustice is being re-discovered and used as a tool to express disapproval and outrage at the injustices in our country. We have witnessed space being occupied in order to express social unity, as well as the destruction of space to express its values of oppression, and lastly the re-claiming of space to express a new social identity. Therefore, it will be through an understanding of the relationship between social injustice and space that we might find spatial justice.

Edward Soja first theorized his ideas in his book *Seeking Spatial Justice* (2010). His writings are a continuation of the ideas of Lefebvre (1991) who speaks about the relationship between space and social being, which he refers to as *social space*. Soja was also inspired by geographers such as John Rawls (2003) and David Harvey (1973) who both wrote about social injustice in their respective literatures. Spatial justice explores these concepts and combines them to create a holistic understanding of the complexities between them. In doing that he was able to provide a more tangible theoretical lens through which one can understand space. In order to understand spatial justice, we need to first understand the individual pieces from which it grew.

SOCIAL SPACE

As introduced in the first chapter, social space refers to the relationship between the physical spatial realm and the social public realm. According to Lefebvre (1991) social space is not a space that exists solely to enclose social happenings, like a container. Instead it is a social composition that is put

together due to its interactions with the social public realm, which in turn defines that space accordingly. It is the dynamics between the physical materiality of space and the social relations that occur within that space.

Soja (2009:2) talks about three principles that the concept of spatial justice depends upon that is deeply rooted in Lefebvre's' ideas of social space:

Firstly, to accept that we are all social beings which then translates spatially in our nature.

Secondly, the acknowledgment that space is socially produced, which in turn implies that it can therefore be socially challenged and changed.

And lastly that the spatial qualities of everyday life have the ability to shape social circumstances, and inversely how social circumstance has the ability to change our spatial environment.

SOCIAL INJUSTICE

From Lefebvre's writings on the inter-connected relationship between spatiality and social being, we now explore the second piece of the foundation of spatial justice, which is the idea of social justice.

Edward Soja refers to the idea of social justice as written about by John Rawls. In his book *Justice is Fairness* (2003), Rawls summaries social justice as a direct response to one of the fundamental cores of a democratic society: freedom and equality. He believes that as people of the earth, we all belong to the same collective of humanity, and therefore one person can not claim more rights than another.

He defines a situation to be unjust if it can be considered to be oppressive or obstructive to another persons access to their human rights and freedoms, and their opportunity to live a acceptable healthy life. This system looks to ensure that those who are less advantaged or marginalized receive their fair share of benefits and assistance.

SPATIAL JUSTICE

The concepts of spatiality, social being, and justice, are the three pieces that make up Edward Soja's theory of spatial justice. The combination of these three aspects allow us to understand the complex relationships between each element. According to him, spatial justice explores the dynamic relationship between social justice and its spatial dimension, and the manner in which these two components interact with each other. The spaces that emerge from this interaction can either be considered just or unjust. Simply put, it is a means of exploring justice from a perspective that is critically spatial.

By recognizing that the spatial components and qualities of the environment we set ourselves in has the ability to affect all aspects of our social lives both positively and negatively, we begin to understand the impact of space, knowledge and power on our everyday routine and how it can be either oppressive or enabling. By thinking spatially about social justice we are able to uncover clues in our environment that could be contributing to unjust circumstances. As architects we then have the ability to use our practical knowledge to get involved more effectively, and to create spaces within the community that are just, fair and speak of democracy and equality.

A spatial justice lens provides architects and spatial planners the opportunity to fully emerge into an exploration of site and its social complexities (Themba 2011). Through this theoretical lens we are able to situate our entire being - physically, mentally emotionally - into understanding and experiencing what factors are influencing the production and definition of space in a specific context.

The basis this dissertation project lies in its extensive understanding of site and context. It is necessary to understand both physical strengths and shortfalls; as well as its social, economic, and cultural implications. The architectural objective of empowering the everyday to become extraordinary requires a comprehensive understanding of the ritual of the everyday person, an understanding of what is holding them back, and where their potential lies.

At this point in the dissertation the ideas of spatial justice are still theoretical. We understand that the physical manifestation of space within the precinct in Joubert park is directly influenced by the social beings living in that space and their interactions within that space. In order to understand how this can be applied to the project site we will look at how academics in the urban planning and architectural field have developed this theory of spatial justice into a methodology that can be used to analyze and interpret the site and space.

“

4.2 THE METHODOLOGY

The writings of Edward Soja (2009 and 2010) helped define the relationship between social injustices in the public sphere and the spatial implications of these injustices in the urban fabric. Sarah Mina Basset (2013) in her thesis *The Role of Spatial Justice in the Regeneration of Urban Spaces*, uses the theory of spatial justice as written about by Soja (2010) and methodologies written about in UCLA's Critical Planning (2007), and was able to take it one step further by translating the concept of spatial justice into a methodology for understanding and analyzing urban space.

She begins by breaking up spatial justice into 3 categories (see figure 4.1). Spatial claim, spatial power and spatial linkage. She defines spatial claim as the communities ability to “live, work and experience space” within their community (Basset 2013:5). Spatial power is similarly defined as the communities ability to “succeed in or contribute to space” in their community (Basset 2013: 5). And the last sub-section of spatial justice is that of spatial linkage. Basset (2013:5) continues to define this as the communities ability to “access and connect to and with other spaces” in and around the community.

For each of these sub-sections of spatial justice she has developed a series of investigative questions, spatial qualities that speak to intentions of each sub-category, and measurements against which a person could measure the just or unjust nature of a space (see figure 4.2-4.4).

If emphasis is put on the spatial quality of an environment during its re-generation, and the correct questions are asked regarding socio spatial relationships, it could reduce the unforeseen social impacts of the physical interventions.

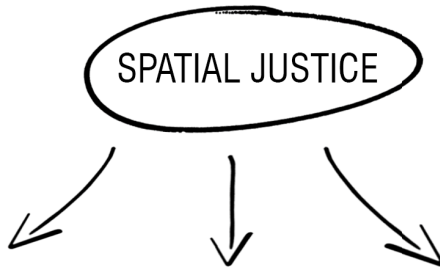

SPATIAL CLAIM

the ability to live, work and experience space



SPATIAL POWER

the ability to succeed in and contribute to space

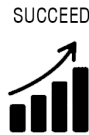

SPATIAL LINKAGE

the ability to access and connect to space



FIGURE 4.1 SPATIAL JUSTICE
A diagram illustrating the sub-sections of spatial justice.

SPATIAL CLAIM

This category of spatial justice refers to a persons right to living and being in their community. Spatial claim looks at the persons right to not only live in a community but also their right to work within that same community wherein he sleeps, and additionally his right to enjoy and experience various social platforms that the community has to offer (Basset 2013:5). A scenario that can be considered spatially unjust from the perspective of spatial claim is cases where a persons right to a space is questioned, where commuter rights or the rights of others are put ahead of the right of the resident.

The following investigative questions were derived from the research of Basset, and can be used to explore this condition of spatial claim in a community:

- Who has taken ownership of the place? Who is restricted from using the space?
- What is the relationship between past history and current community?
- How is the space currently being lived in?
- What work is a person able to do in the space?
- What does a person do for recreation in the space?

Spatial qualities to consider when designing for spatial claim are:

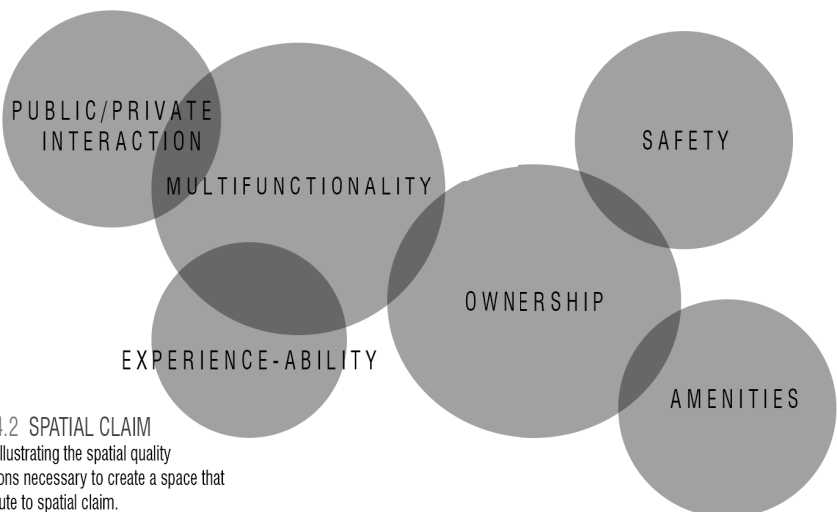

FIGURE 4.2 SPATIAL CLAIM
A diagram illustrating the spatial quality considerations necessary to create a space that can contribute to spatial claim.

SPATIAL POWER

This category of spatial justice refers to a person's right to have success within a community, and then conversely his responsibility to contribute back to his community using the skills and talents he has acquired to reach his success (Basset 2013:5). A scenario that can be considered spatially unjust from the perspective of spatial power is when by-laws are put in place by outsiders that place trade restrictions on specific areas such as public parks or urban public spaces.

The following investigative questions were derived from the research of Basset, and can be used to explore this condition of spatial power in a community:

- What emotive qualities could be used to describe this space?
- Is the community able to practice freely? To contribute to space? and create here?
- What special skills or talents do the people of this space have?
- Is there any preventative barrier in place stunting the current community from participating fully in public life?

Spatial qualities to consider when designing for spatial power are:



FIGURE 4.3 SPATIAL POWER

A diagram illustrating the spatial quality considerations necessary to create a space that can contribute to spatial power.

SPATIAL LINKAGE

This category of spatial justice refers to a persons right to connect and have access to other spaces around their community, and the accessibility of their own community to people outside of the community (Basset 2013:5). A scenario that can be considered spatially unjust from the perspective of spatial linkage is when an area is not well connected to main transport routes as to cut off its physical connection to surrounding spaces.

According to Basset (2013:6) the following investigative questions can be asked to explore this condition of spatial linkage in a community:

- Are there any physical barriers in the environment?
- What are the invisible barriers that are either historical, social, political or cultural that divides the area?
- Whose history, heritage, and memory belongs in this space?
- Is this space physically and socially connected to other spaces?

Spatial qualities to consider when designing for spatial linkage are:

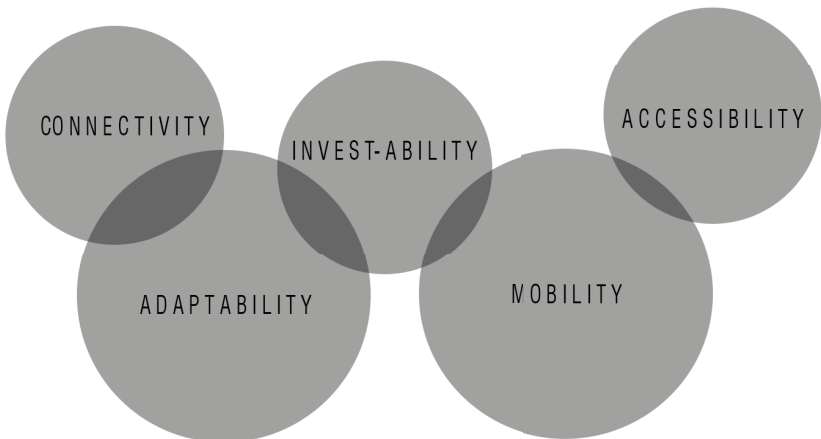

FIGURE 4.4 SPATIAL LINKAGE

A diagram illustrating the spatial quality considerations necessary to create a space that can contribute to spatial linkage.

4.3 THE THEORETICAL ANALYSIS

This section looks to use the methodology as developed by Basset (2013) as a tool to investigate and understand the socio-spatial relationships on my project site as defined in chapter 3. The project specifically explores the existing living residential model in the city, trying to understand what opportunities have been created in this living environment over time and what is holding its residents back in terms of personal and family growth in the city. Furthermore it investigates the trading opportunities in the precinct in order to discover the spatial consequences or barriers of survivalist trade. And lastly it looks to understand the positive and negative social networks on the site and how these translate spatially in the environment. The analysis will take part in two parts, firstly an analysis of the social relationships and inequalities on site with a supporting photographic study of these scenarios. The second part will then look to explore each of the issues spatially through a series of diagrams that could lead to a complete spatial understanding of the social realities on site. The following study was undertaken with the help of additional sources to assist my own understanding of the intangible nature of the site. Anthropological studies by Kihato (2013) and Marais (2013), whose work is specific to the precinct, and a documentary by Bestall (2012) on the living conditions in Hillbrow, were all used as supportive sources to my own observations. The following is a diagram and site plan of my site over which I will be mapping the social networks and spatial implications of this investigation:

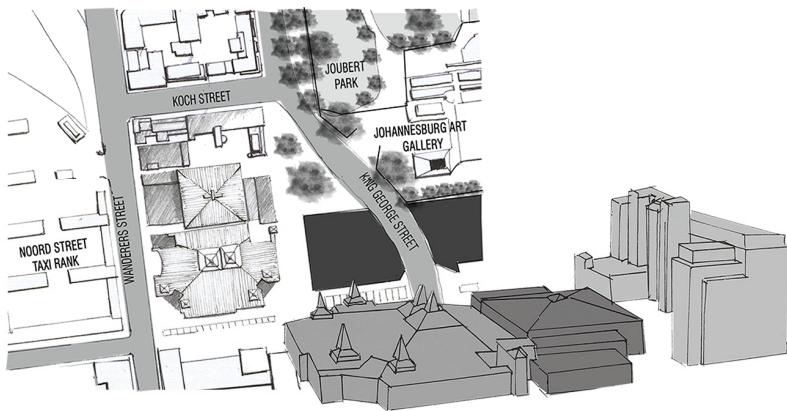

FIGURE 4.5 SITE MAP
A diagrammatic site map and 3D diagram of my site, which is a residential tower and retail mall development.

4.3.1 THE SOCIAL FABRIC ANALYSIS

SPATIAL CLAIM







EXISTING SPATIAL QUALITY RATING		
public/private	<i>disconnected public and private realms</i>	
multi-functionality	<i>additional supportive functions on site not integrated well enough</i>	
experience-ability	<i>Fast paced movement and high volumes and safety prevent dwelling on site</i>	
safety	<i>High crime rate, better in visible spaces (park). Dangerous in hidden spaces (alleyways etc.).</i>	
ownership	<i>Ownership of individual spaces, not of public spaces</i>	
amenities	<i>Very limited access to amenities</i>	
<p>Who has taken ownership of the place? Who is restricted from using it?</p> <p>The space is in a state of decay due to the lack of ownership by the larger population of the park. A few groups of people attempt to repair this by creating initiatives for community participation to integrate the larger community. These people are mostly retired and unemployed members of the community (figure 6) who monitor the park daily and act as guardians of the park.</p>		
<p>What is the relationship between past history and current community?</p> <p>The parks heritage and memories do not belong to the existing residents of the park. The existing population is largely a foreign migrant population, who have little relation with the heritage of the park. This leads to the lack of ownership of the larger heritage structures mentioned earlier. However examples of where these structures have been re-appropriated for new use shows the communities interest and its value in the community example: the bandstand being converted into a crèche, and the re-appropriation of residential buildings. Residents take ownership of their smaller flat and their physical contents and possessions rather than the larger communal space (figure 7) as they believe that it is someone else's space and they do not want to intervene.</p>		
<p>How is the space currently being lived in?</p> <p>As mentioned many of the people and families that have settled in the area take ownership of their space and re-appropriate it according to their specific needs (figure 8). Initially when new city dwellers move to the area they occupy a part-time flat (figure 9) with the intention of moving out as soon as possible and therefore do not take ownership of that space.</p>		
<p>What work is a person able to do in the space?</p> <p>As Joubert park is pre-dominantly a residential area, many of its occupants find work elsewhere, either in the northern suburbs or in the CBD. However, it has also developed into a transport-interchange overtime, so new arrivals in the area, mainly the men, begin by becoming taxi-drivers (figure 10). The taxi industry is an already saturated industry in the inner city, many working long hours and find themselves stunted in personal growth and experience. The women often revert to survivalist informal trade (figure 11) as a means to get by while waiting for their paperwork to be processed so that they can find a more stable form of work. However paperwork can take years to process due to lack of resources and corruption, therefore they find themselves stuck in this survivalist strategy.</p>		
<p>What does a person do for recreation in the space?</p> <p>People who work during the week use the park as a space of recreation during the weekend in the form of picnics and church services. Within the built fabric of the residential buildings we see that spaces have been re-appropriated for social use. For example the roof space is used for laundry (figure 12) and social discussions between the women, the old "service dwelling" on the roof has most of the time been converted into a gym for the men (figure 13). and the stairways and circulation spaces (figure 14) are used as play spaces for children in the building.</p>		



FIGURE 4.6 GUARDIANS OF THE PARK



FIGURE 4.7 LACK OF OWNERSHIP IN THE PUBLIC SPHERE



FIGURE 4.8 RE-APPROPRIATED LIVING SPACES

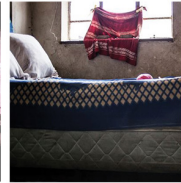

FIGURE 4.9 TEMPORARY SQUAT FLATS



FIGURE 4.10 TAXI CULTURE OF JOUBERT PARK



FIGURE 4.11 SURVIVALIST TRADE



FIGURE 4.12 SOCIAL LAUNDRY ROOF

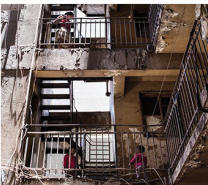

FIGURE 4.13 CIRCULATION PLAY SPACE



FIGURE 4.14 RE-APPROPRIATED TO A GYM

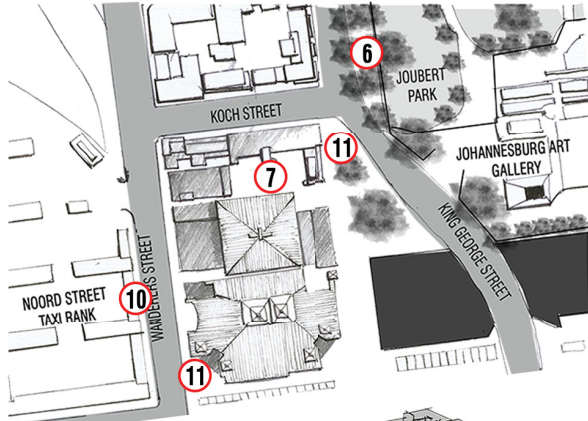
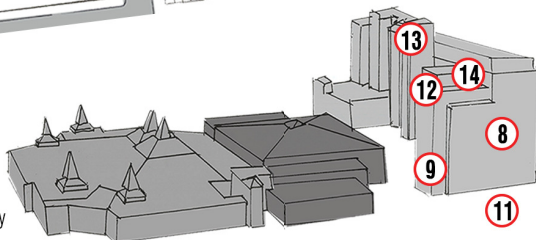

FIGURE 4.15 SITE MAP

A diagrammatic site map used as key for locating study



SPATIAL POWER



EXISTING SPATIAL QUALITY RATING		
social cohesion	<i>exclusion and marginalisation on site</i>	
ability to grow/expand	<i>limited opportunities for growth</i>	
cultural expression	<i>initiatives taken to provides platforms for cultural expression</i>	
economic opportunities	<i>limited economic opportunities available</i>	
access to resources	<i>limited access to valuable resources education, skills training etc.</i>	
<p>What emotive qualities can be used to describe the place? The precinct of Joubert Park can be described as an incredibly vibrant space with high energy (figure 15). However, when you look closer you notice elements of lack of maintenance (figure 16), illegal activities and general degradation of space leave the area feeling dingy. As an outsider moving through the space, you are very promptly made aware that you do not belong there and that it is dangerous for “our type”. You are left feeling excluded and unsafe.</p> <p>Is the community able to freely practice, contribute and create in the space? There are moments of restriction and moments of freedom in this area. Trade is incredibly restricted, with informal trade banned from inside the park area. Informal trade along the street edges also requires a permit, which is hard for foreign migrants who are still trying to sort out their legalities. Additionally, regarding the foreign migrant population, they are often seen being picked up by the police (figure 17) with their stock confiscated. This power is being abused by the police as daily this cycle continues with no assistance from the police or home affairs with this matter.</p> <p>What skills or talents do the people of the space have? On weekends in and around the park is filled with street musicians (figure 18), comedic performers and dance groups, these are mostly the younger population of the park. With regards to the trade we see very little ingenuity around what is being sold, vendors selling only what is accessible to them (figure 19). This gives us the opportunity to make these traders aware of the skills that they have and then assist them in the development of it.</p> <p>Is there preventative barriers in place stunting the current community from participating in public life? There are invisible social barriers between the various micro-communities within the area. These micro-communities often revolve around nationality. Each micro-group lays claim to a certain trade or space or area, and if one groups tries to cross another group it causes tension in the area. A larger problem of economic exclusion is also prevalent, with many outsiders from the northern suburbs of Parktown and Sandton made to feel unwelcome and unwanted in these areas. Physically, there is also fences in place to seclude the general public from spaces that are supposed to be accessible (figure 20), such as JAG and the green house.</p>		



FIGURE 4.15 VIBRANT ENERGY



FIGURE 4.16 LACK OF MAINTENANCE



FIGURE 4.17 JMPD OUTSIDE JAG



FIGURE 4.18 STREET ARTISTS



FIGURE 4.19 TRADING SKILLS



FIGURE 4.19 TRADING SKILLS



FIGURE 4.20 FENCED OFF JAG

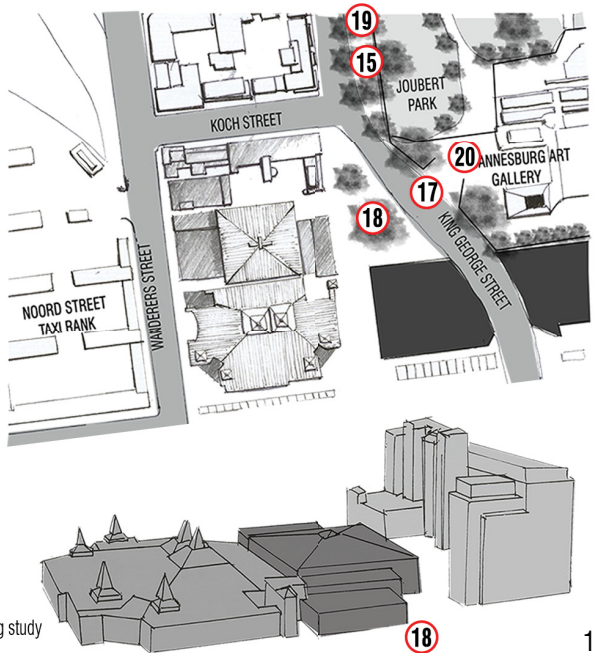

FIGURE 4.15 SITE MAP

A diagrammatic site map used as key for locating study

SPATIAL LINKAGE

EXISTING SPATIAL QUALITY RATING		
connectivity	<i>well connected with various forms of transport</i>	
communication	<i>social barriers restrict communication between groups</i>	
invest-ability	<i>area in threat of gentrification</i>	
mobility	<i>pedestrian mobility is restricted by physical barriers on site</i>	
accessibility	<i>social barriers limit access to outsiders</i>	
<p>Are there any physical barriers in the environment?</p> <p>There are many physical barriers in the landscape. The sunken train-tracks forms a significant barrier between the park and the CBD (figure 21). Additionally there are barriers on the roads splitting areas in half, disrupting pedestrian movement (figure 22). There is also fences that are used to privatise the heritage structures for safety purposes (figure 23) that begin to exclude the general public. The high volumes of traffic form another barrier along the streetscape (figure 24), making it difficult for the flowing pedestrian movement. The façades of the buildings themselves create barriers between public and private space (figure 25). Additionally the mass of the bridge mall acts as a barrier in the urban fabric by blocking the pedestrian movement moving from the park to the modes of transport.</p> <p>What are the invisible barriers that are either social, political, cultural?</p> <p>There is a larger social barrier separating the entire Hillbrow triangle from the more exclusive northern suburb neighbourhoods on its edges (figure 26). Similarly within the triangle the communities are broken down into smaller-micro communities based on their nationality. There is a cultural barrier between the memories and heritage of the park and the new community of the park.</p> <p>Whose history and memory does the space belong to?</p> <p>The history and memory of the park belongs to the British settlers who came to south Africa in search of gold. They had developed the park in the same language as their home country, making it difficult for new users of the park to appreciate its value. A way to reconnect the user of the park and its history is to re-appropriate this historic structure to speak to the needs of its new user.</p> <p>Is the space physical and socially connected to other spaces?</p> <p>The Joubert Park Precinct is incredibly well connected in the larger context of Johannesburg because of its various means of transport infrastructure. With Park Station and Noord St taxi rank to its west, the MTN local taxi rank to its southern edge, and a BRT route along its eastern border, this site is completely inter-connected to its surroundings. However, there is a large social barrier separating the park from the rest of Johannesburg. Class, money and race divide the bordering communities around the park, with many "outsiders" feeling unsafe and unwelcome in the inner city, and therefore have built their walls higher and turned their back to any connecting with the precinct.</p>		



FIGURE 4.21 RAILWAY BARRIER



FIGURE 4.22 INFRASTRUCTURE AS BAFRIER



FIGURE 4.23 FENCE AS BARRIER



FIGURE 4.24 TRAFFIC AS BARRIER



FIGURE 4.25 DEAD EDGE BARRIER



FIGURE 4.26 BARRIER BETWEEN HILLBROW
AND PARKTOWN

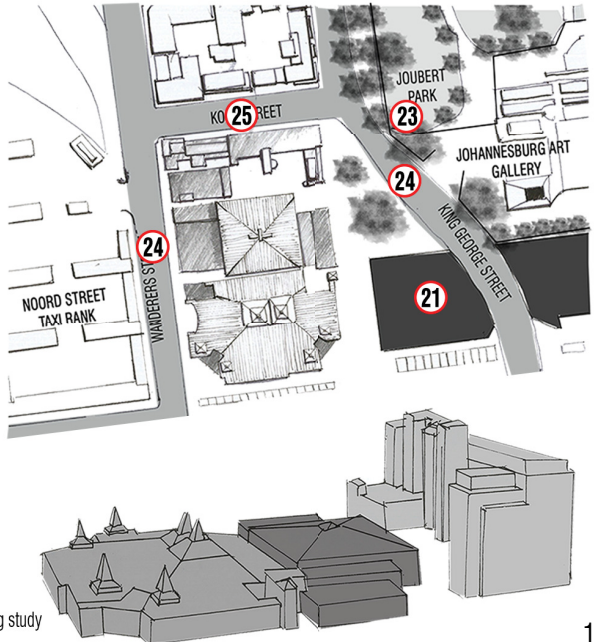

FIGURE 4.15 SITE MAP
A diagrammatic site map used as key for locating study

4.3.2 THE SPATIAL FABRIC ANALYSIS

In this section we will explore the issues or injustices discovered in the previous section and investigate how they have manifested spatially in the urban landscape in and around the project site. It begins with a spatial investigation from larger urban point of view, exploring the issues of spatial linkage and accessibility in and around the city block on which the site is located. It then works its way through the intricacies of the fabric on the site, looking at the spatial power of the resident, and the means they use to try and find success in their living environment, and lastly it will unpack the manner in which people live in the city and how it affects their experience of simply being in the space.

At the end we would have a synthesised spatial map that depicts which spaces are just/unjust on the project site and how to then use this as a resource in the future spatial development of the site.

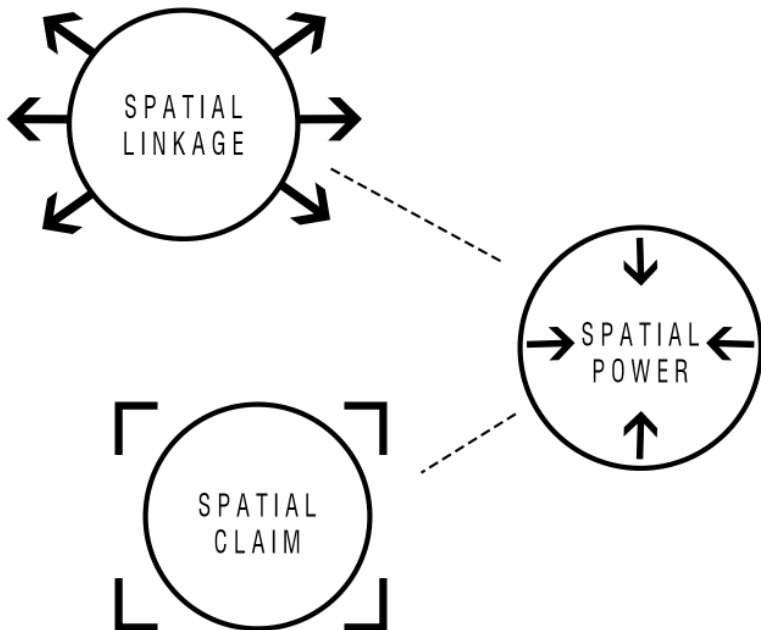

FIGURE 4.27 SPATIAL JUSTICE MAP

This diagrammatic map illustrates the methodology which the spatial study will follow in order to get an in-depth understanding of site

SPATIAL LINKAGE: *Connectivity and accessibility of the project site*

1. BUILDINGS AS BARRIER

The diagram below illustrates characteristics of spatial injustice with regards to the hindered pedestrian mobility on the site. The three masses form a barrier to the pedestrians moving through the park to the Noord St taxi rank and Park Station. Restricted side streets saturated with parked vehicles also limit mobility on site.

FIGURE 4.28
SIGNIFICANT PEDESTRIAN TRAFFIC



FIGURE 4.29
HINDERED PEDESTRIAN MOVEMENT

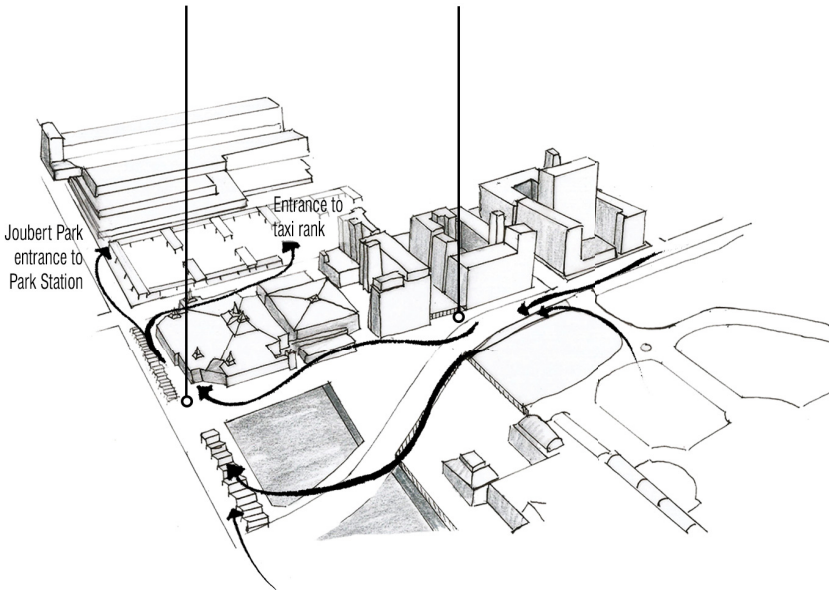

FIGURE 4.30 HINDERED MOBILITY
A diagram illustrating how physical barriers dictate movement on site

2. TRANSPORT DISCONNECTED FROM PEDESTRIAN

The points of entrance of the transport infrastructures in the precinct are important nodes in the social context of the site. However, we can see from figures 4.31 and 4.32 below how the taxi rank entrance is spatially disconnected from the main movement routes and how the park station entrance, which is a service entrance in reality, has not been invested in. This illustrates the cities opinion of the value of the people living in Joubert Park. Which in turn affects their perception of their own value, stunting community growth.

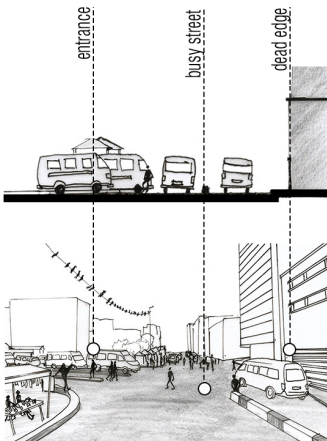

FIGURE 4.31 NOORD ST TAXI RANK (1)
Diagram illustrating the disconnected entrance of the taxi rank from the main movement routes.

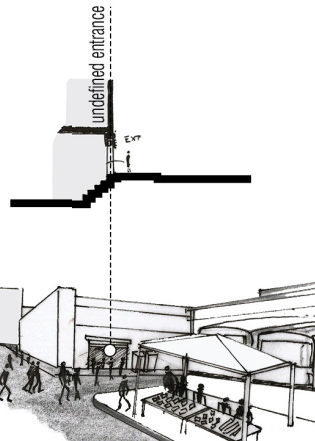

FIGURE 4.32 PARK STATION ENTRANCE (2)
Diagram illustrating the undefined/blunt existing entrance to Park Station from Joubert Park.

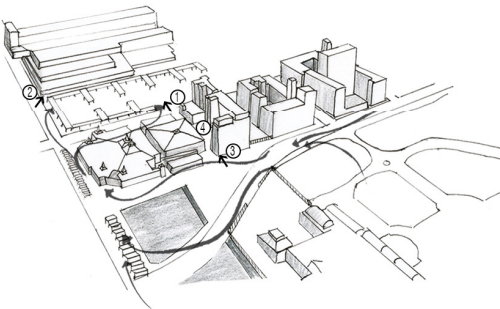

FIGURE 4.33 SITE MAP

A 3d site diagram used as a key to locate points of importance

3. INACCESSIBLE RESIDENTIAL STRUCTURES

The residential tower located on the project site is disconnected from the public realm. For the residential dweller the entrance is a steel door located on the corner edge of the building which is slightly offset from its retail facade. It does all it can to be hidden. The dweller then walks through into the internal void space and makes his way through to the main circulation core. This space is dark and unsafe as it was enclosed even further by the storage structure built right up against it. The lack of connectivity between the residential dwelling and the public sphere is isolating these structures and contributing to the creation of smaller social groups. There is a lack of communication between these micro-groups which leads to a disconnected condition between social groups.



FIGURE 4.35 HIDDEN RESIDENTIAL ENTRANCE(3)
Photograph of current main entrance into the building which is completely shut-off and inaccessible to the outsider

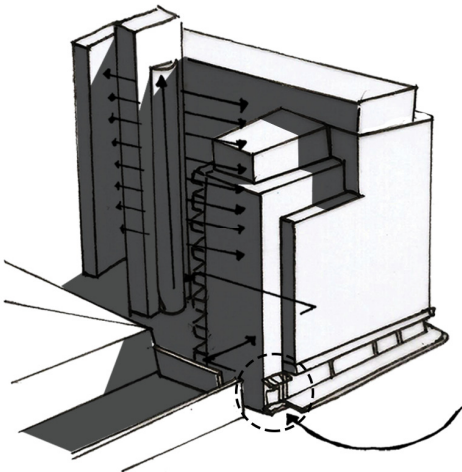

FIGURE 4.34 CIRCULATION
Diagram illustrating the manner in which the dweller would approach the building and navigate its internal spaces.

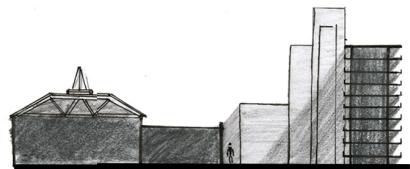

FIGURE 4.36 BLOCK SECTION (4)
Section through the city block illustrating the dark internal courtyard space enclosed by the retail structure

SPATIAL POWER

Opportunities of success on the project site

1. THE SPATIAL MANIFESTATION OF SURVIVALIST TRADE

The main form of income on the site is from survivalist trade. In the study area we find four various types of this trade, which we have compared in order to determine where the opportunist for growth lie. In order for a community to exert there power in a space, they need to have the ability to grow and succeed as an individual in that space. Today, growth is often determined by income, which makes the availability of economic opportunities and resources on site vital.

The traders ability to exert their power in the space is being restricted by the physical limitations and barriers on the site. Dead edges and infrastructural barriers influence and limit the way people move through site, making it difficult for static traders, such as the mall and residential edge shops, to interact with possible customers and limiting successful trade to specific movement routes. Street traders who have the ability to adapt to the movement of the site are more successful in this precinct due to their flexibility.

There is also a lack of interaction between the various levels of trade that you see elsewhere in the country, where informal traders support formal shops and act as their “legs” on the street. By fostering a relationship between them, we can create opportunities for the trade networks to strengthen and grow.

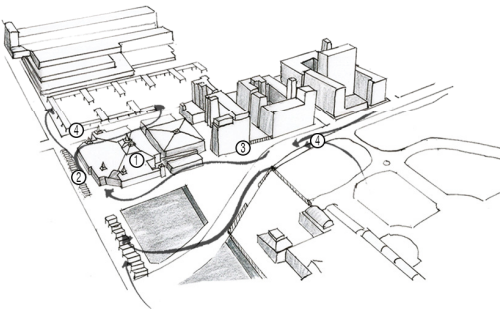

FIGURE 4.37 SITE MAP

A 3d site diagram used as a key to locate points of importance

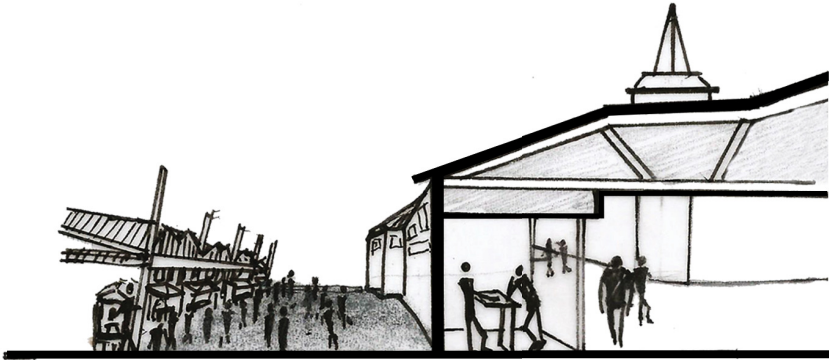

FIGURE 4.38 THE MALL*(1) VS THE MARKET (2)
Section perspective comparing the success between the market and the mall on site.



FIGURE 4.39 RESIDENTIAL RETAIL EDGE (3)
Section perspective illustrating the disconnect between building and street edge, due to the vast pavement space.



FIGURE 4.40 INFORMAL TRADE AT THE PARK (4)
Section perspective illustrating the disconnect between building and street edge, due to the vast pavement space.

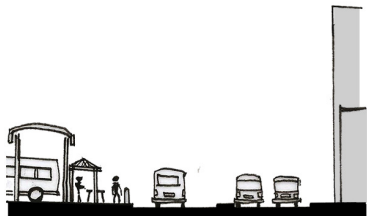

FIGURE 4.41 INFORMAL TRADE AT RANK (4)
Section perspective illustrating the disconnect between building and street edge, due to the vast pavement space.

2. POSITIVE CULTURAL EXPRESSION

When a group is able to express themselves, their identity, their culture, their traditions, or their heritage in a space, they are able to exert their power in that space and take ownership of it. It is within this type of environment that communities are inspired to contribute and share knowledge and help each other succeed.

Within the public realm surrounding the site it rare to see a group expressing their identity. However, once in a while you do experience this cultural re-birth in the inner city. Mainly through avenues of the youths do we see young people wanting to get in touch with their culture and heritage, and express it through poetry dance, music and art in the public realm.

The large pavement that is a hindrance on a normal everyday scenario. However, it becomes an incredibly vibrant event space a few times a year. This “empty” space provides the platforms for their voices to be heard. Here we see how through space the everyday can be empowered to become extraordinary. In this scenario it is a space of justice.

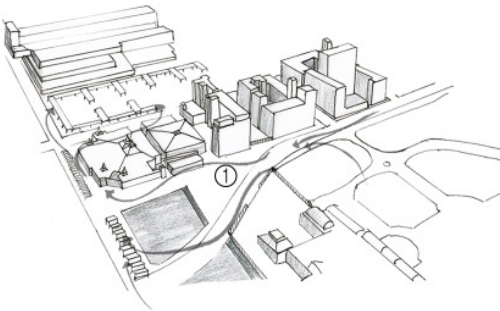

FIGURE 4.42 SITE MAP

A 3d site diagram used as a key to locate points of importance



FIGURE 4.43 PAVEMENT AS BARRIER (1)
Drawing illustrating the everyday condition of the space in front of the residential building, which is relatively quiet.



FIGURE 4.44 PAVEMENT AS EVENT SPACE (1)
Drawing illustrating the extraordinary condition of the space in front of the residential building, when it is converted into a platform of empowerment.

SPATIAL CLAIM

Livability of the project site

1. RE-APPROPRIATED LIVING

The residential building, known as Constantia, on the project site is made up of various different social groups, each of these groups have claimed their space in this building and formed their own micro-communities within it. Some of these groups have positively re-appropriated their living space to suit their immediate needs. Others, who do not see this as a permanent living solution, have not taken ownership, and have simply left it in its deteriorating condition.

These living scenarios illustrate how community members have claimed their own private environments, and formed their social networks within it. The injustice, however, lies in how limited this scope of spatial claim is. This investigation illustrates possibilities of how we can encourage the community to take ownership of spaces outside their four walls, by creating environments with similar spatial qualities that encourage interaction and social cohesion.

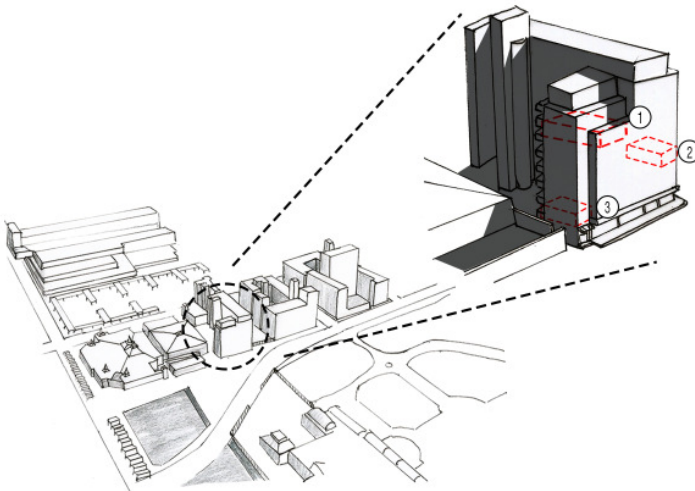

FIGURE 4.45 SITE MAP

A 3d site diagram used as a key to locate points of importance

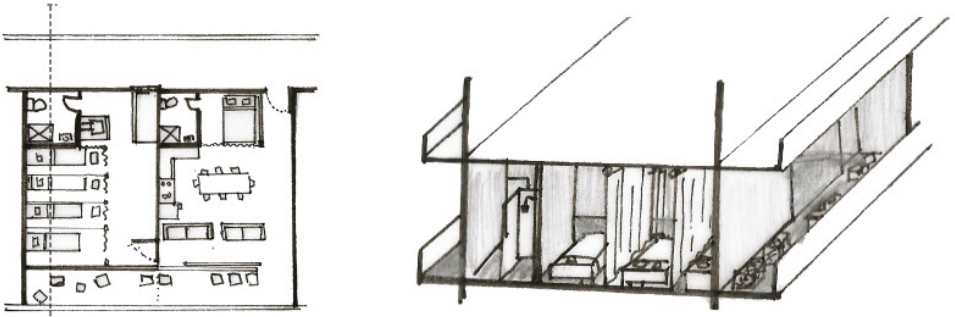

FIGURE 4.46 COMMUNAL LIVING (1)

Diagrammatic plan and section illustrate how these two flats have created a communal living space, with one room used mainly for sleeping and the other for eating and socialising, the balcony between the two have been combined as a larger outdoor social space.

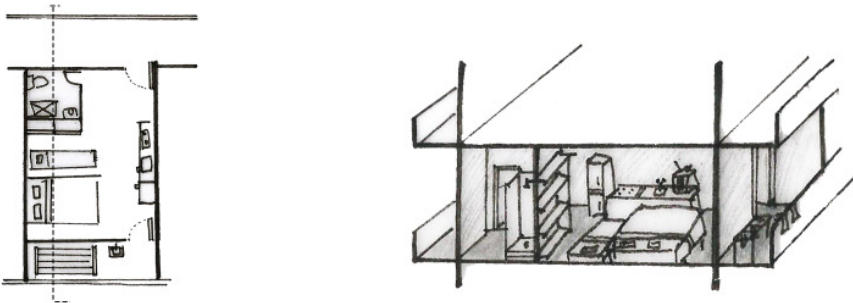

FIGURE 4.47 LIVE COOK CLEAN (2)

Plan and section illustrate how this one bedroom is used as a bedroom for 3, with cooking and laundry happening within the small flat space.

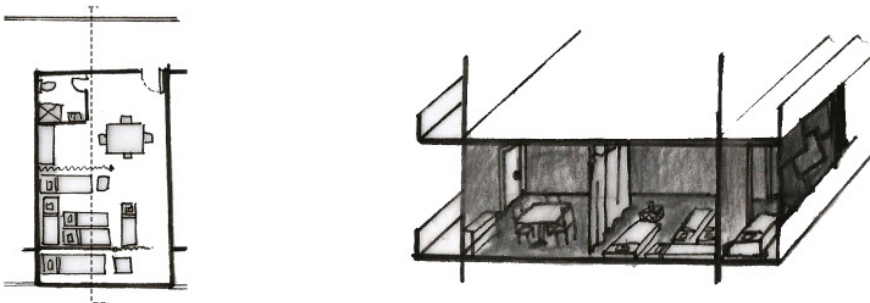

FIGURE 4.48 DRUG DEN (3)

Plan and section through a drug den which is located in the darkest part of the building. The balcony has been boarded up to allow no visibility in or out of the room. Living conditions are bad with high levels of over crowding.

2. RE-APPROPRIATED PLAYING

Within the residential fabric, the smaller social groups have re-appropriated spaces to respond to their social needs. Figure 4.48 is a section through the servants quarter on the roof which has now been converted into a social laundry gathering space for the women, and a gym for the men.

The circulation spaces have been claimed by the children of the building as their official play space. While the rooms are small and congested, the passageways and fire escapes offer enough space for the children to play while their parents watch on from their flats. However as with figure 4.51 we see some passage areas are incredibly dark and underlit, these spaces tend to be the more dangerous spaces in the building, and children are often warned to play in those areas.

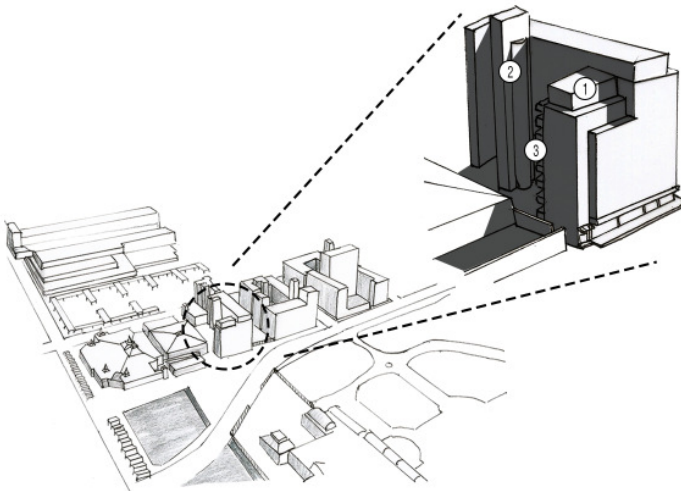

FIGURE 4.49 SITE MAP

A 3d site diagram used as a key to locate points of importance

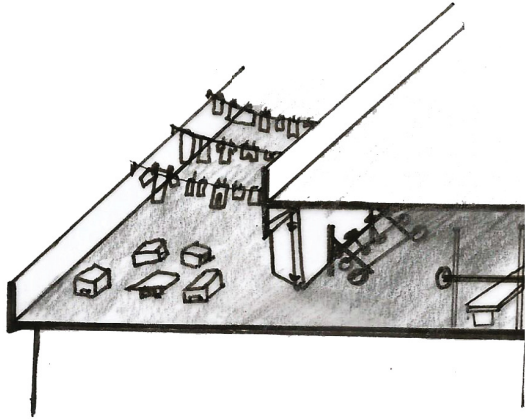

FIGURE 4.50 SOCIAL ROOF (1)

Diagrammatic plan and section illustrate how these two flats have created a communal living space, with one room used mainly for sleeping and the other for eating and socialising, the balcony between the two have been combined as a larger outdoor social space.



FIGURE 4.51 UNLIT PASSAGEWAYS (3)

Diagrammatic plan and section illustrate how these two flats have created a communal living space, with one room used mainly for sleeping and the other for eating and socialising, the balcony between the two have

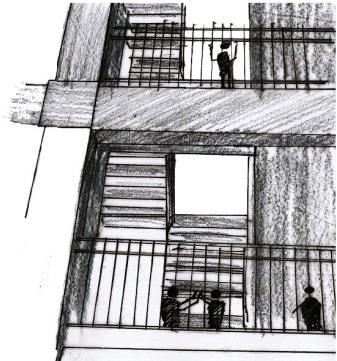

FIGURE 4.52 SOCIAL CIRCULATION (2)

Diagrammatic plan and section illustrate how these two flats have created a communal living space, with one room used mainly for sleeping and the other for eating and socialising, the balcony between the two have been combined as a larger outdoor social space.

4.4 THE OUTCOMES

From this investigation we can draw a few conclusions about the status of the site in terms of spatial justice:

When we consider the site the perspective of **spatial claim** we find two larger categories against which we can measure the just-ness of the site. On the one hand we have the problem of ownership. No one necessarily claims the whole precinct and takes ownership of it outside their own four walls. However, on a micro-level we see individuals taking ownership of their own flat/ area around their stall etc. Spatially we need to look at how to re-appropriate existing urban fabric to give it value to the community, which in turn would lead to the ownership of that fabric. The second measurement looks at use of space. This is an incredibly high density area that is well used. The buildings are over-populated and the recreational facilities are deteriorating because of use with no maintenance. However during the day during work hours, the precinct is a lot less busy with many of its occupants leaving to find work outside of the area. The site cannot be considered just from a spatial claim point of view, but through a series of interventions relating to economy in the area and the relationship between past and present it is possible to create a spatially just area that accommodates for all aspects of its users life, who then takes ownership of the space and maintains it accordingly.

From the perspective of **spatial power** the precinct itself is well equipped with what is necessary to live and succeed in the city. It boasts high-density residential living, recreational green spaces, largely connected transport systems and a basic retail sector. However, the flaw lies in the ability of these systems to expand. Most of these were put in place in the early 1900s with no intention of further expansion. Today, with over-populated dwelling spaces, there is a desperate need for expansion and adaptability. Residents see that there is no means of expansion and so do not envision a future in this precinct, this limits their ownership in the space, which often leads to the degradation of the fabric. Similarly there is no infrastructure in place to help support and develop the skills and talents of the new city user in order to produce a trade model that is unique in what it can offer the rest of the city.

Lastly from a **spatial linkage** point of view we find that the space is well connected and linked to its surrounding context, in terms of transport infrastructure. From the point of the pedestrian there are physical and social barriers in place that limit their accessibility to areas within the precinct and isolate other spaces from the larger system creating dead spaces within the urban fabric.

While the idea of spatial justice is a hypothetical ideal and not necessarily something that can be accomplished in the real world, through spatial intervention we can attempt to minimize the role that space has in creating unjust and oppressive environments, by focusing on creating empowering spaces of justice instead.