



1907, postcard view of Yeoville



1907, Yeoville terminus

3. YEOVILLE

3.1. THE DEVELOPMENT OF URBAN FORM

Yeoville's establishment continues the narrative of urban development that characterised Johannesburg's settlement. Its inception is saturated with the fantasy of escaping the uncontrolled mining development when Johannesburg was bursting at its seams a mere four years after its declaration. Yeoville was envisioned as a suburb that would distinctly separate the new social class of Johannesburg in an exclusive escape to the natural landscape. To facilitate the principle of social distance as elaborated on by Nuttall & Mbembe (2008:21), the Witwatersrand which formed a physical barrier to the north of the mining belt was appropriated to isolate the suburb from the spatial vicinity of the mine workings and its lodging-houses, brothels, gambling joints, outlandish cafes, boisterous theatres and illicit bars (Meiring 1985:87).

Yeoville lies on the farm Doornfontein that bounds the edges of the original Uitvalgrond. When Yeoville was founded by the Johannesburg Estate syndicate in 1890 it developed slowly and by 1896 only 484 of its 1214 stands had been sold. It was probably again laid out in 1902 and belonged to Thomas Yeo Sherwell, to whose second name Yeoville was known (Meiring 1985:87).

The investigation into the history of the development of Yeoville was conducted in the same manner as for Johannesburg and the results mapped in context of the legislation that significantly influenced its development. Legislation is an invisible network of regulations and boundaries. In the mapping exercise it is placed in relation to the development of Yeoville's physical urban form where its impact on how space is being used and perceived is pronounced.

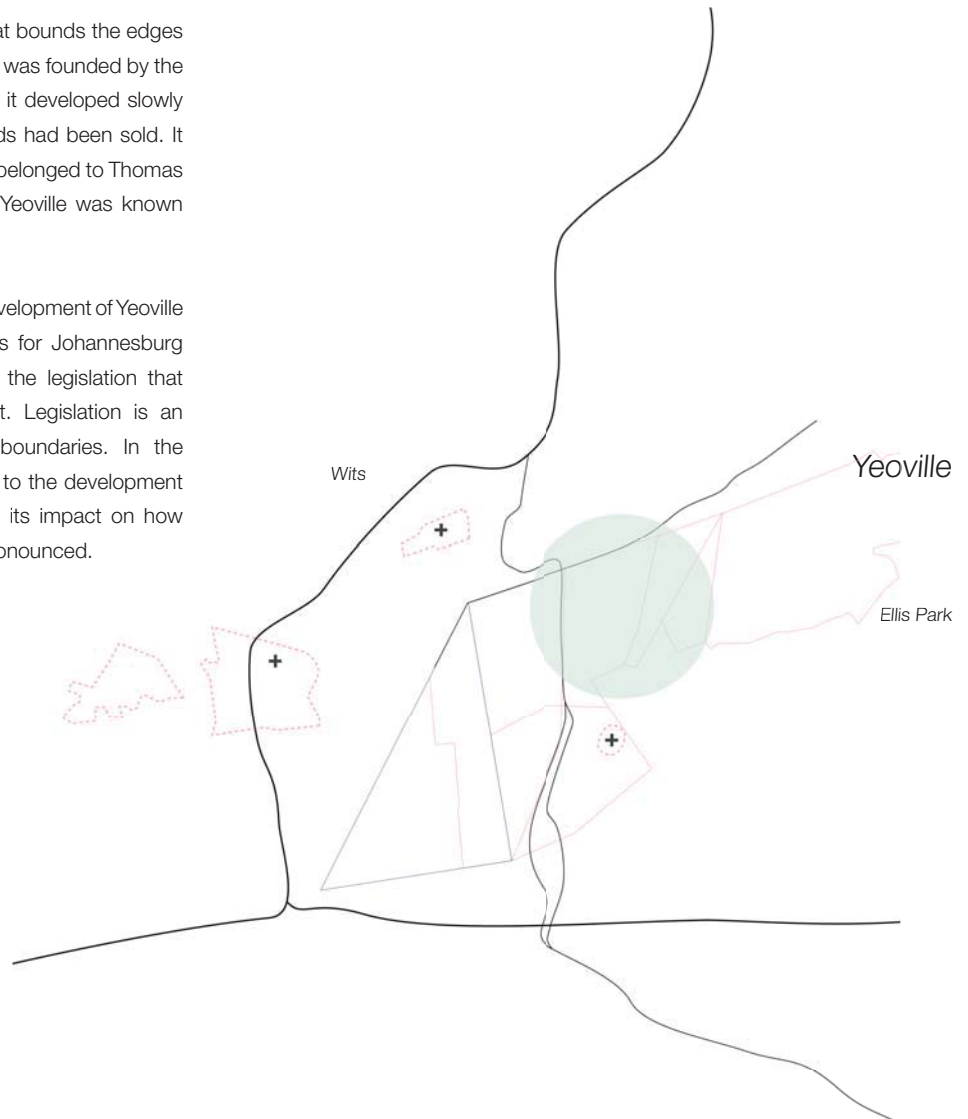

Location of study

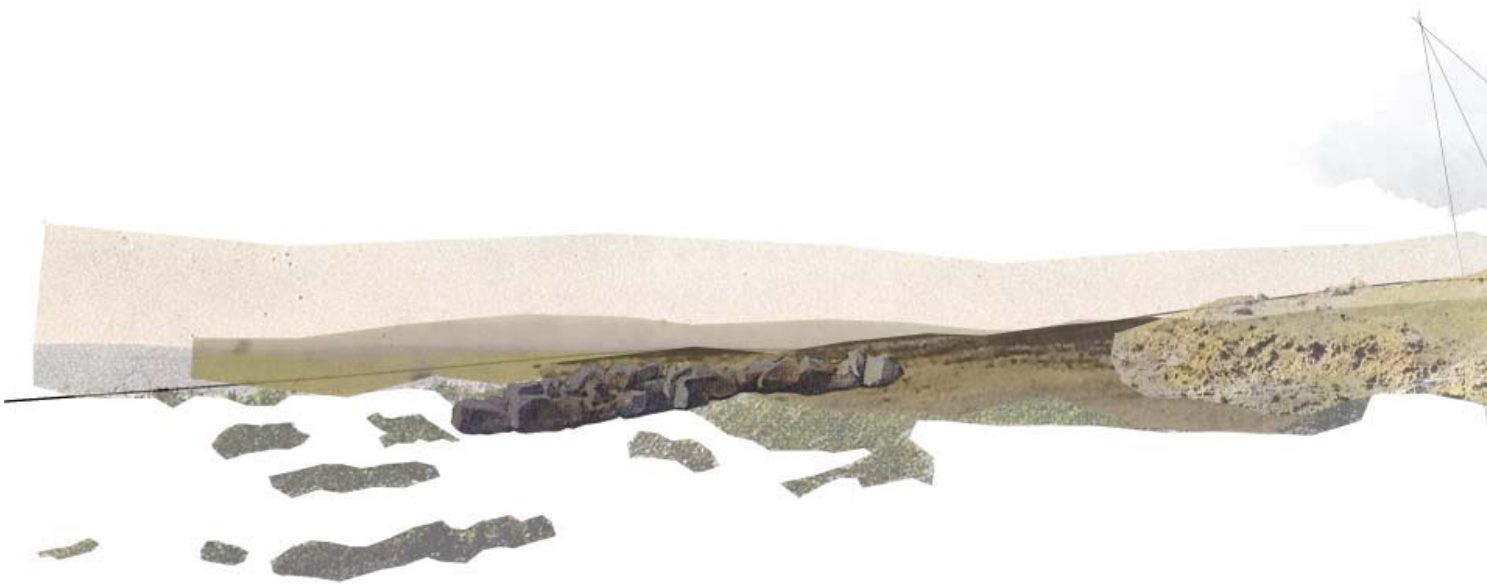

Yeoville Plateau before the development of Johannesburg



The fantasies that generated urban form

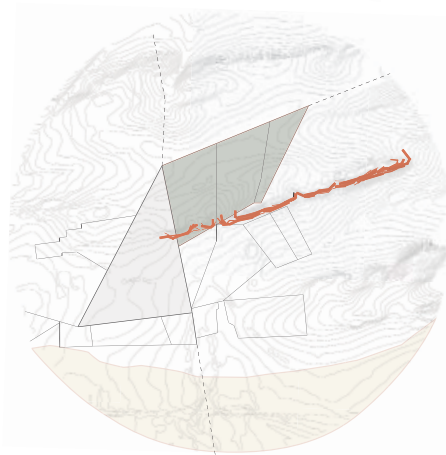

Suburban development to the north:
Yeoville, Bellevue and Bellevue-East

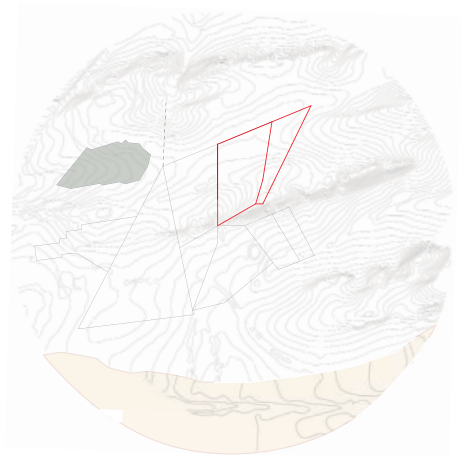

Parktown

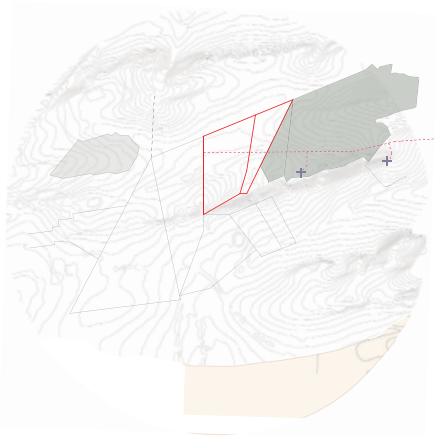

Observatory

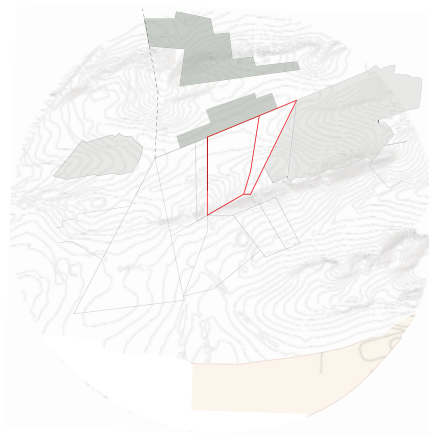

Houghton

Legislation and the development of Yeoville

1890S	PROCLAMATION OF YEOVILLE	
1910 /1920		Jews that achieved economic security and social status moved to the north-eastern parts of Johannesburg, giving rise to the Jewish communities of Yeoville and Judith's Paarl. The number of Jewish residents was so high that the suburb became colloquially known as 'Jewville' (Rubin 2004; 95).
1930S		After the Great Depression construction started yet again in Yeoville in 1933 developed into a typical middle-class area. Detached and row houses alternated rental apartment blocks and condominiums (sectional title flats) offered living space for younger newcomers of the population and the growing number of transients in their first step on the housing ladder (Jürgens 1993; 311).
1948	IMPLEMENTATION OF APARTHEID	
1950	GROUP AREAS ACT	
1970S	RELAXATION OF GROUP AREAS ACT	The aim was to create homogeneous residential areas inhabited by only one population group (Jürgens 1993; 309).
1980S		The aging white inhabitant population, high spatial mobility of young white persons, the traditionally high proportion of immigrants from overseas and the resultant cosmopolitan image of these areas meant that non-white in-migration was met with weak political resistance. Anonymous and unsupervisable high-rise or middle-rise apartment blocks could arguably also have further mobilised transformation. (Jürgens 1993; 310)
1991	SCRAPPING OF THE GROUP AREAS ACT	In-migration was initiated by affluent coloureds and Indians. (Jürgens 1993; 310) It was not until later that blacks and non-whites of generally lower social status followed from the CBD and neighbouring areas of Hillbrow and Berea. The population in Yeoville North of Raleigh Street (the main commercial street) was characterized by Orthodox Jewish communities with kosher shops, a Jewish kindergarten, a school and a number of synagogues and Torah centres. (Jürgens 1993; 312)
1994	DEMOCRACY	The area south of Raleigh Street was characterized by an ethnic variety students and self-employed people (musicians, actors, journalists) who contributed to the liberal and cosmopolitan atmosphere. As the cultural centre for many persons belonging to intellectual and student circles Rockey/Raleigh Street, its restaurants, clubs and of shops attracted young people in particular. A number of welfare organizations and a choice of rent-protected one room apartments also accomodated a concentration of retired people. (Jürgens 1993; 312)
PRESENT		People from any background and race could acquire property and settle anywhere, providing their personal income allowed them to do so (Jürgens 1993; 313). When Yeoville was red-lined by the banks some of Jewish community were forced to abandon their properties and reluctant landlords who could not sell their houses resorted to renting them out. At the same time, there was a great influx of people from all over South Africa and the neighbouring countries who wanted to be closer to the city centre. It was a liberal and cosmopolitan destination that received the influx of African immigrants with open arms. Rockey Street remained a hotbed for radicals, activists and musicians. Journalists from all over the world came and lived in this place and would mingle. After the repeal of the Group Areas Act institutional and private discrimination continued to exist. (Jürgens 1993; 313) Red-lining by banks and finance companies prevented credit from being given to buy and maintain real estate in the area and as a rule residential areas in and near the downtown see a tendency toward slum growth.



The development of urban fabric

Together with Yeoville, Berea and Bellevue were the first residential suburbs on Doornfontein to develop to the north. Chipkin (1993; 11) described these compounds of the rich with their heightened expectations, as the corpus of Victorian urbanization and an extension of the vast scale of instant Victorian townscape that was developing. (Chipkin 1993; 7)

A residential boom saw gardens planted with exotic saplings brought up from the coast by the wagonload to effect instant ecological change, creating tree lined streets and lush suburbia on the formerly treeless plateau. (Chipkin 1993; 25) Victorian houses sprung up on comparatively small lots that are homogenous in size in a rigid street grid that was super-imposed on the landscape.

It has been illustrated before that Johannesburg was a direct outlet for the architectural styles of the time. Apart from the Victorian manner in which Yeoville was formed, Modernism was the other spatial paradigm that had the biggest influence on Yeoville's urban fabric.

Modernism removed itself from traditional styles and forms (Chipkin 1993; 89) and was predisposed to the latest stylisms and hybrid forms of the predominant Art Deco movement in New York (Chipkin 1993; 92). The suburb has over two dozen Art Deco residential blocks - most true to the style of symmetrical lines, rounded corners and balconies with modernist touches. The architects responded to Yeoville's hills and dales by imaginatively curving the blocks around corners. The new types introduced an imposing scale on the existing low density fabric. Unique with portholes and streamlined mass, the apartment buildings could at once be cruise ships silently gliding on the Witwatersrand plain. As part of the hybrid architecture created at the time, Maisonettes also appeared in large numbers. With four unit blocks around a central staircases, stepped stair towers, projected slabs, rounded balconies and corners they were predominantly white modernist villas with blank cubist forms that alluded to small builders versions of Corbusier pavilions (Chipkin 1993; 124).

1890S
SUBURBAN STREET GRID AND HOUSING¹⁸⁹⁵
NAZARETH HOUSE¹⁸⁹⁵
EASTINGTON MANSION¹⁹⁰⁰

1910 /1920
SYNAGOGUES AND CHURCHES

1930S
YEOVILLE BATHS
ART DECO COURTS: DIAMOND, GRANVILLE, HELVETIA,
RADOMA E.T.C.
THE BEACON ROYAL
MAISONNETTES
BY 1938 YEOVILLE HAD A CINEMA, POST OFFICE, LIBRARY
AND POOL (MEIRING 1993; 88)

1948
1950
1961
THE YEOVILLE RECREATION CENTRE¹⁹⁶⁴
TENNIS COURTS¹⁹⁶⁴

1970S
1980S

1991

1994
1995
CLINIC¹⁹⁹⁸
YEOVILLE MARKET²⁰⁰⁶

COMMUNITY CENTRE ADDITIONS²⁰¹⁵

POLICE STATION
PRESENT

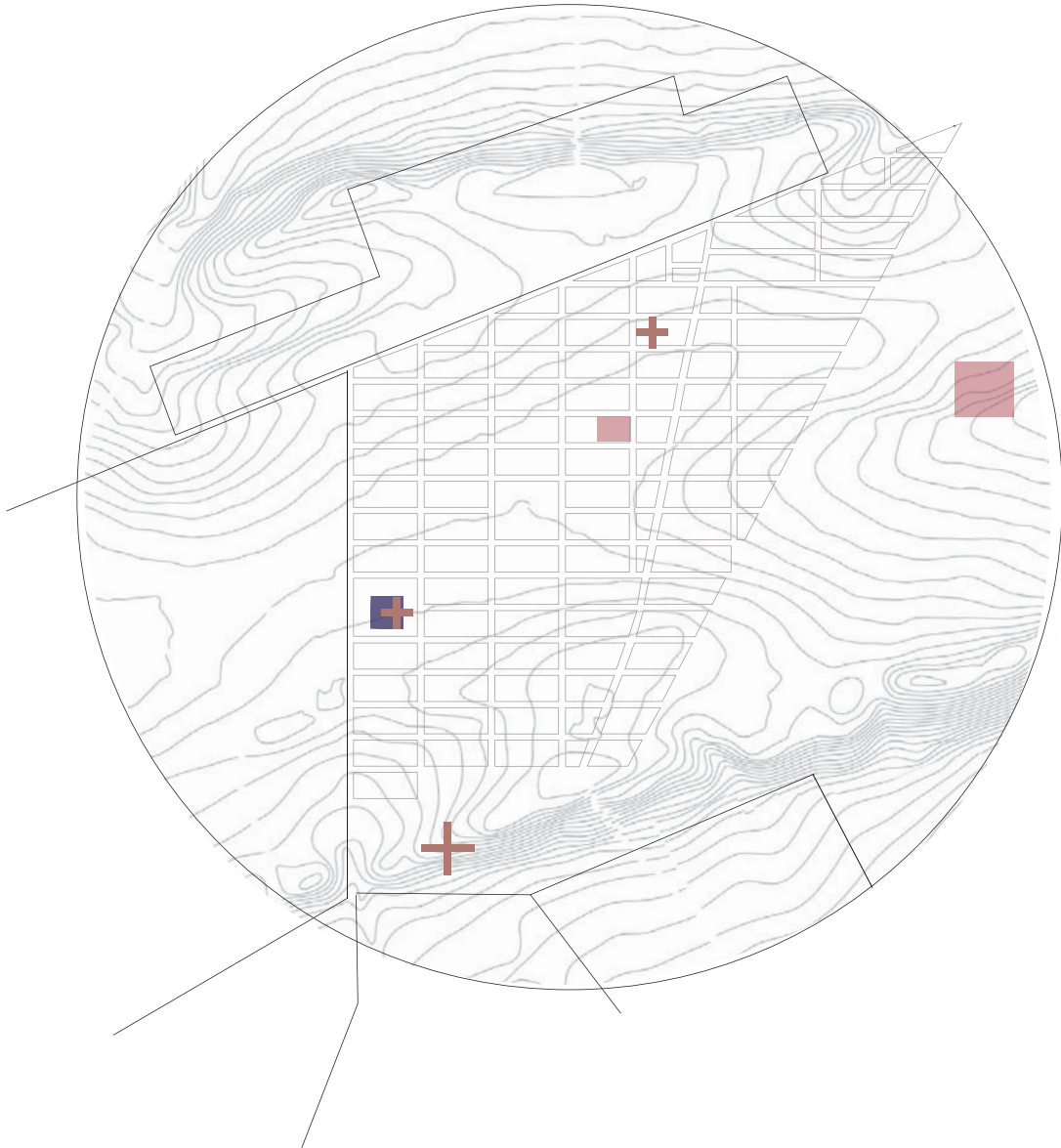



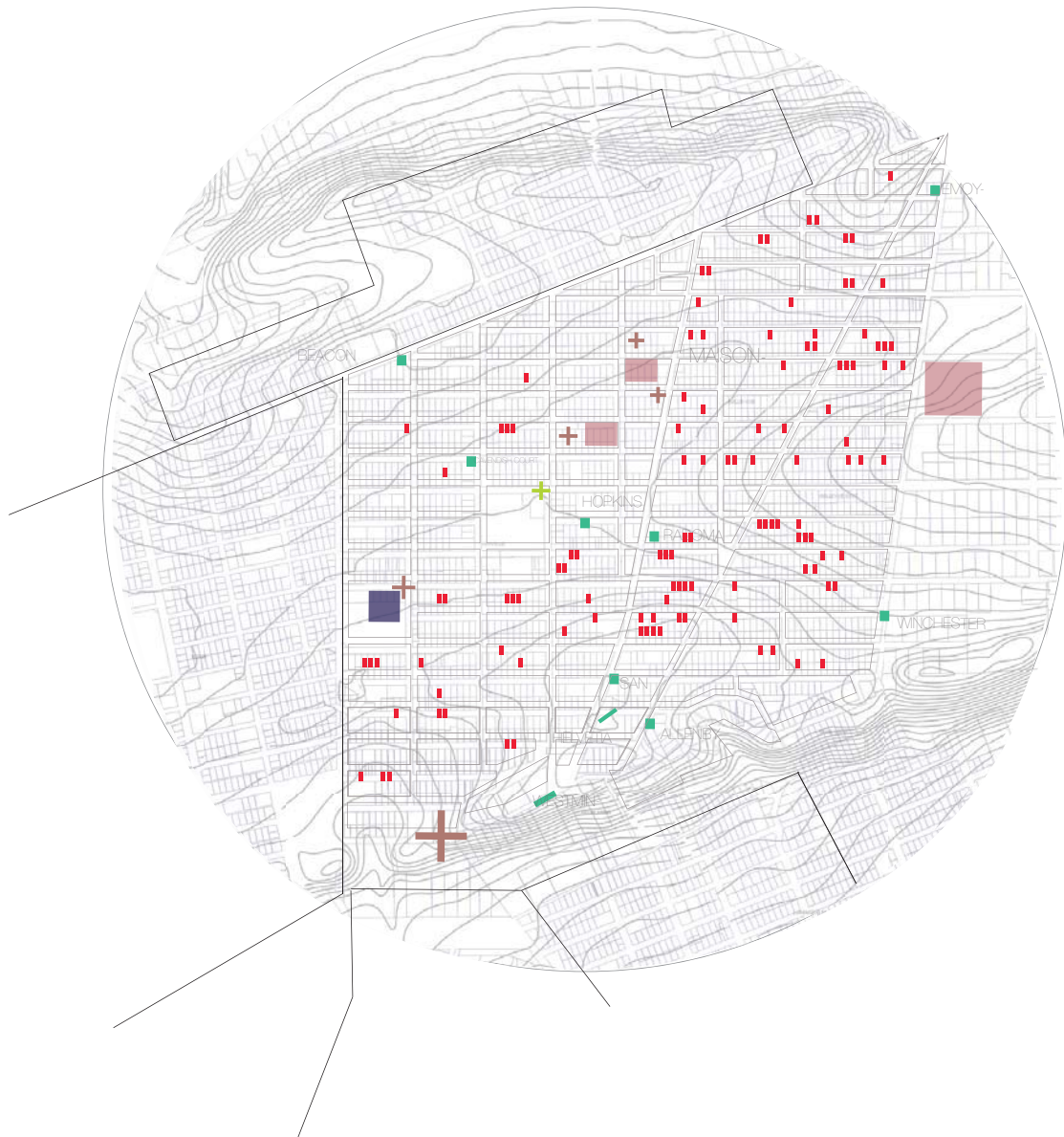

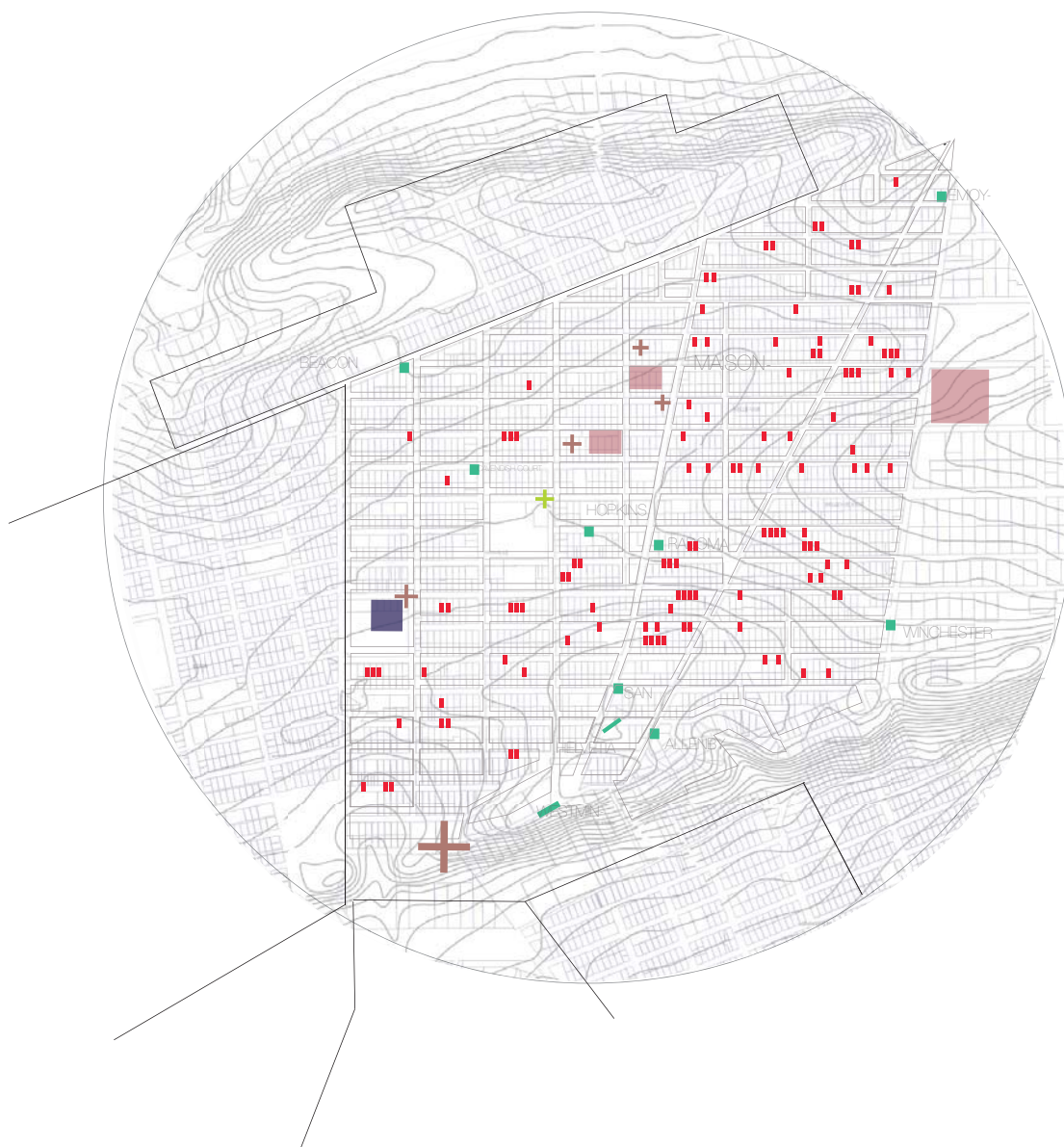

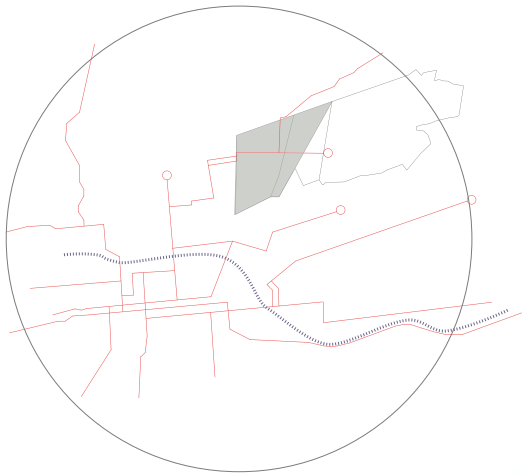



It is evident that Yeoville has been a host to multiple fantasies. From providing an emergent social class with an enclave from mining endeavours to appropriating its physical boundaries as a space to distinguish between colour boundaries only to be the place that once again represents the dissolution of these figurative limitations. Its built fabric is a fragment in its context and has significantly been able to absorb socio-political constructs without significant change to its form. On the 1890 Tompkins Map Yeoville appears in the same shape it is today (Meiring 1985:87). It is possible that its urban fabric has remained intact because buildings simply adjusted well to whatever new programme they were being appropriate for. It is also possible that the form of a building as well as its intended programme remained uninterrupted throughout Yeoville's development.

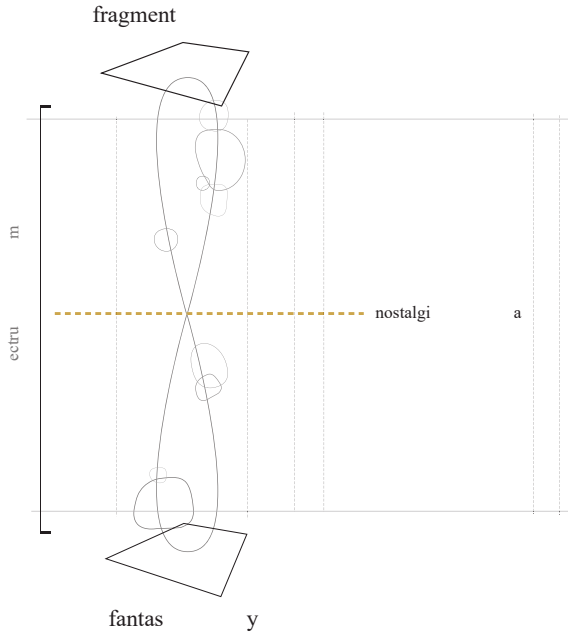

ruimtelike tipologië

Die diagram dien as instrument om die nostalgiese aard van ruimtelike tipologieë in die stad waar te neem om 'n spesifieke veerkragtigheid te identifiseer wat inherent tot die tipologieë en hul karakters is. As gevolg van hierdie kwaliteite word die stad onbewusteloos geprojekteer en gekonstrueer deur die tasbare en ontasbare geheue daarin vervat - die gewaarwording van nostalgie in die materiaal van die stad. Veerkragtigheid word verstaan as die vermoë om fantasie en fragment te absorbeer. In Johannesburg en ook in Yeoville word nostalgie beskou as die onversadigbare en ontevrede hunkering na - en om te fantasieer oor die verlede.

rocky/raleigh straat

eov

Die selfde vorms wat die fantasie van die verlede laat gestalte vind word vandag hergebruik om nuwe fantasieë in nuwe fragmente uit te leef

e a t o f t e c t f a r c t o a s o r e v e o p m e n

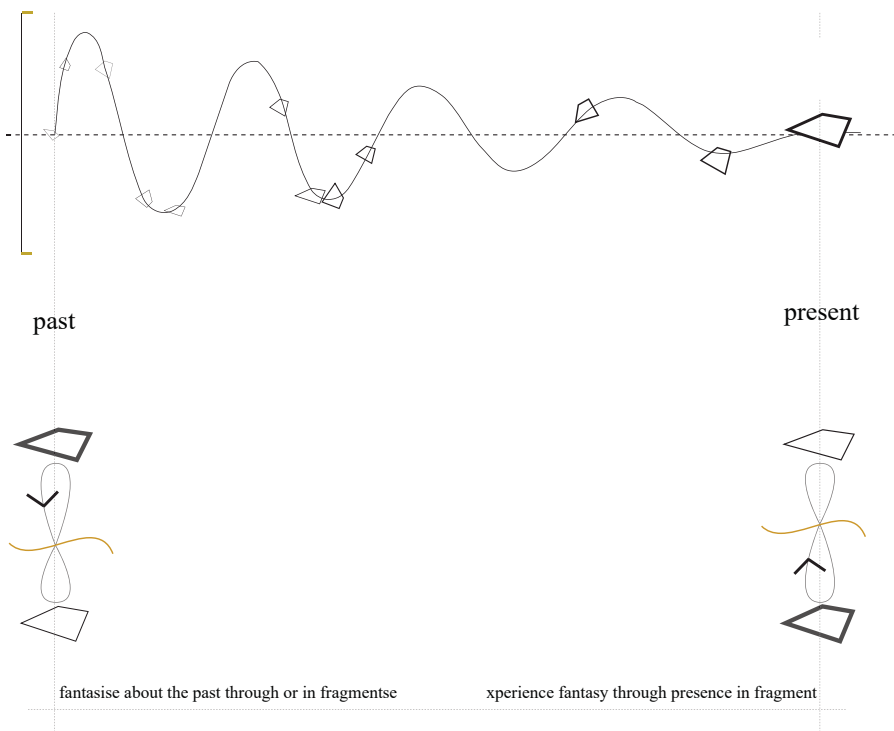

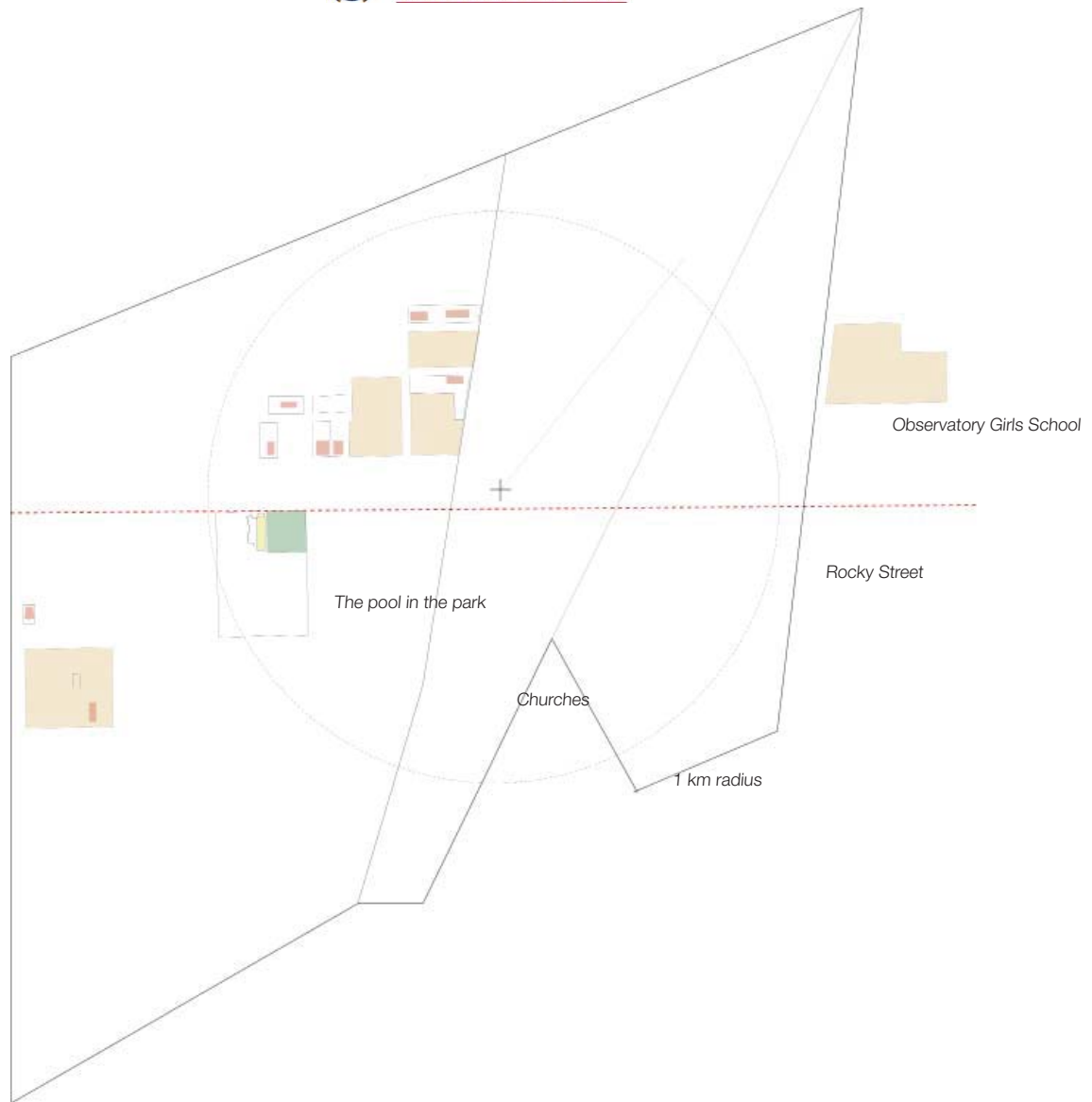

3.2. A MAPPING METHOD

A further mapping investigation identified these uninterrupted forms as schools, churches, Nazareth Home and the public Swimming Pool which can all be traced back to their establishment.

The Yeoville Swimming Pool is a fragment of its urban context, cordoned off by physical boundaries, its use over time manipulates the navigation of non-physical boundaries throughout the development of Yeoville. As a spatial type its ability to rearticulate itself is a useful elaboration on the dynamic character between Yeoville's form and its fantasies. A swimming pool has the capacity to inspire interpretation, analysis, fantasy or narration as a building type, a material philosophy of water, problem of form and in its social ambiguities of use (Van Leeuwen 1998:4). The following exploration into the swimming pool typology unravels the intricate relationship between social engagement and play with water in urban environments. A study of water in architecture enlightens the relationship between the city dweller and their larger natural environment. Water's tactile and temporal quality then gives rise to an exploration to redefine the presence of water and its form in Yeoville.



MAPPING:
ROCKY/RALEIGH STREET

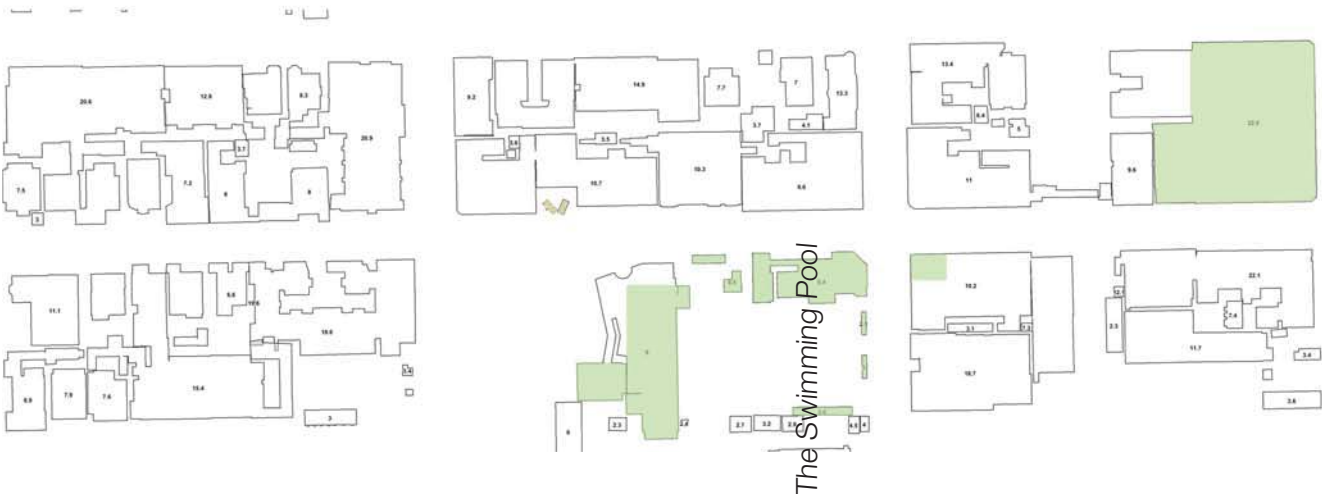

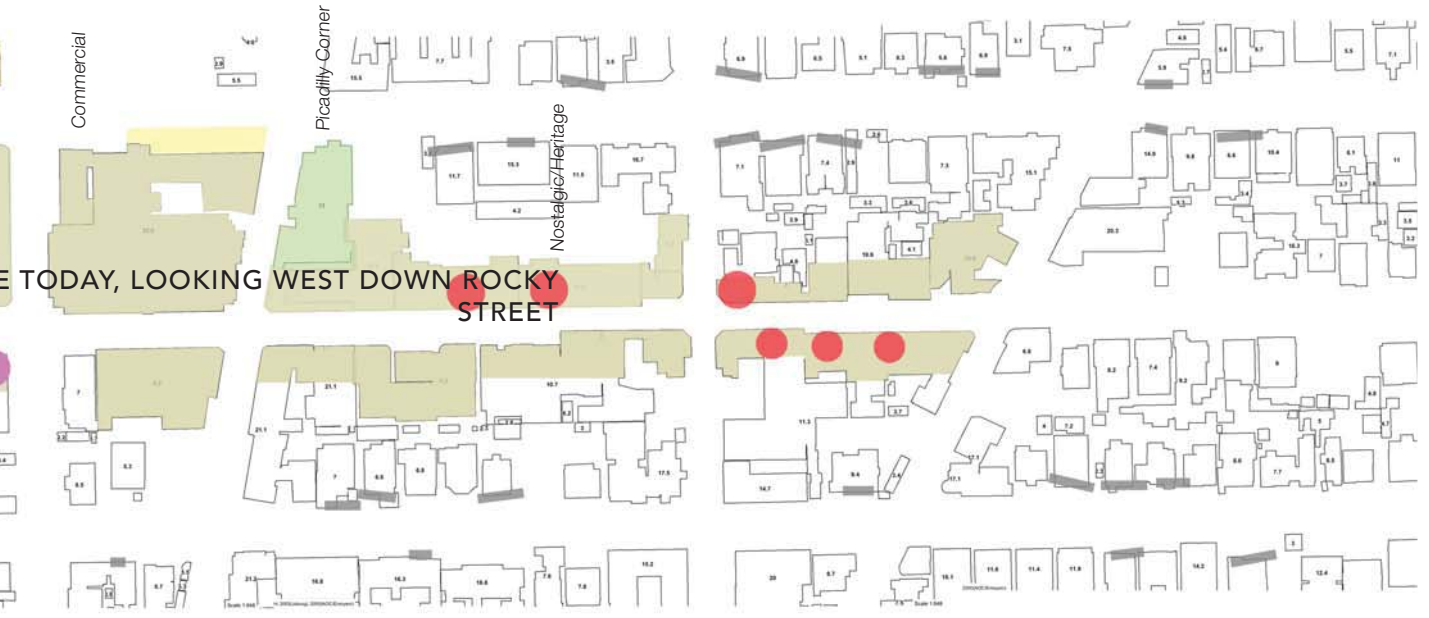



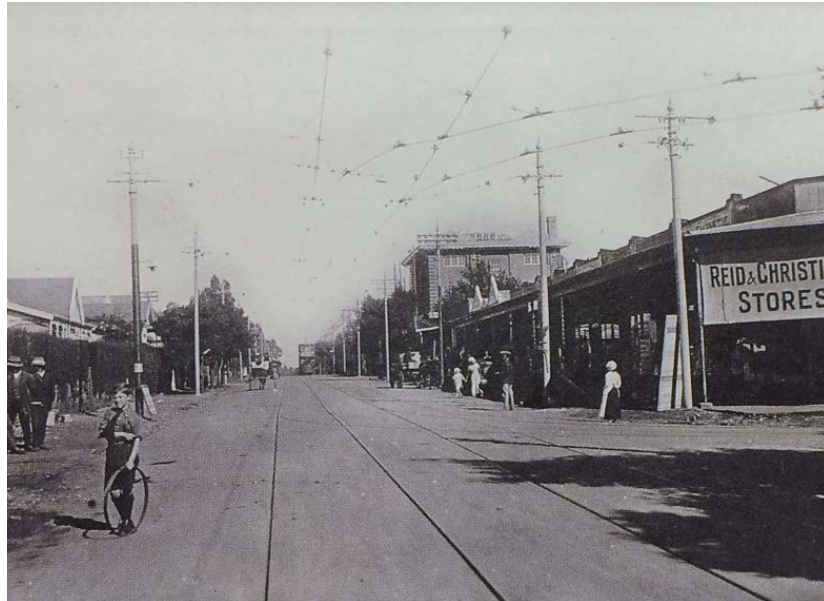

1916, Raleigh Street



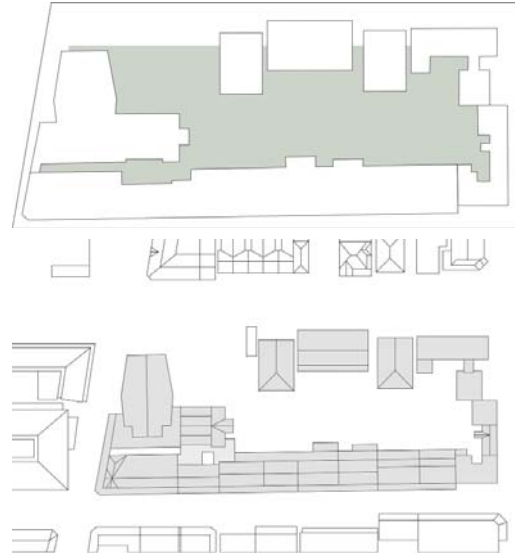
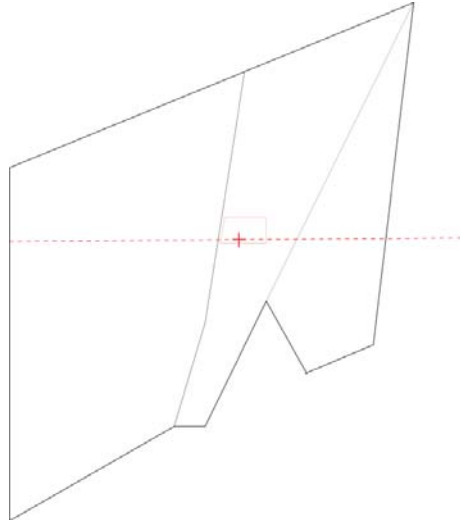

The programmed boundary: The Swimming Pool, its edges, lawn and ancillary structures are enclosed with a brick wall that rises above its users. The entrance to the pool on Rocky Street is the only opening in the wall. The wall conceals the function of the pool from its surrounding context. The boundary of the city block in contrast, reverts the civic relationship between use and street. Commerce and residences line and directly live off of the activity of the sidewalk and the street, neglecting the remaining space of the block behind them.

The re-appropriated boundary: The appropriation of the buildings on the city block runs parallel to the the narrative of Yeoville's dynamic absorption of multiple fantasies in contrast to the Pool's singular programmatic practice.

The boundary and the street: The southern edge of the city block that faces Rocky Street is lined with an Edwardian portico that forms the threshold between street and interior commercial spaces, adopting the role of sidewalk. Later additions to the roof of the Edwardian shops have windows that look out onto the street. The rhythmic columns of the portico create embracing intervals with a domestic scale that has accommodated commercial endeavours since its inception. To the west, Piccadilly Centre faces the

Yeoville Market. The Taxi Rank is an extension of the market and together they make for one of the busiest points on Rocky Street. Users and activities spill out from under the roof canopy onto the street and sidewalk. The ground plane of the market is informally configured and used by pedestrians. The Piccadilly Centre was originally a service station and workshop with subterranean fuel tanks and a large industrial portal frame warehouse. An edge of the warehouse, The Edwardian style commercial building and a detached home that outdates all of the structures on the block then merged into a movie theatre and jazz club. The open plan hall of the warehouse was later also transformed into an indoor shopping centre. To the north, commercial activity dissolves into a residential grain. Detached houses with verandas, Maisonettes with porticos that impose on the sidewalk and floating balconies of modern apartment blocks together compose a transition from the public realm to private residences that is ripe with semi-private retreats. The thresholds also impart visual surveillance onto the street.

The streets around the city block are frequented by commuters, traders and schoolchildren travelling to and from other parts of the suburb to the schools that populate the area North of Rocky Street.

The character of a city street block just east of the Public Park in Rocky Street bears a striking resemblance to the form of the Swimming Pool and its bounding wall. The edges of the city street block are the antitheses of the bounding walls of the Pool, making it a valuable supplementary investigation into the character of the boundaries of fragments in Yeoville. The findings of the investigation are used to inform, underscore and scrutinize the design intervention in the Park and enlightens a perception of how Yeoville's users interact with the street and its edges.

INTERMISSION 2 ANCILLARY SPATIAL ANALYSIS

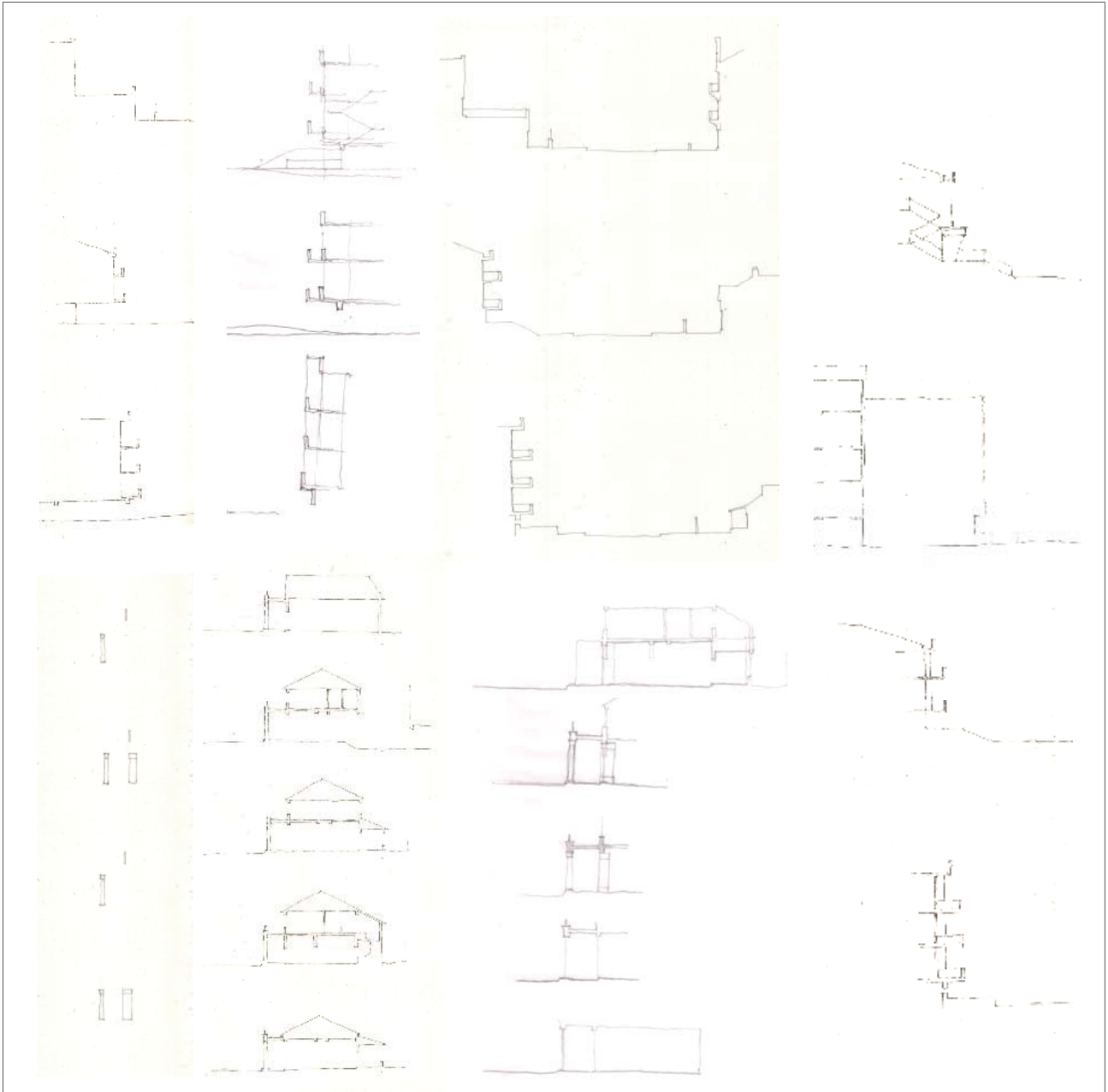

Sectional analysis of street thresholds

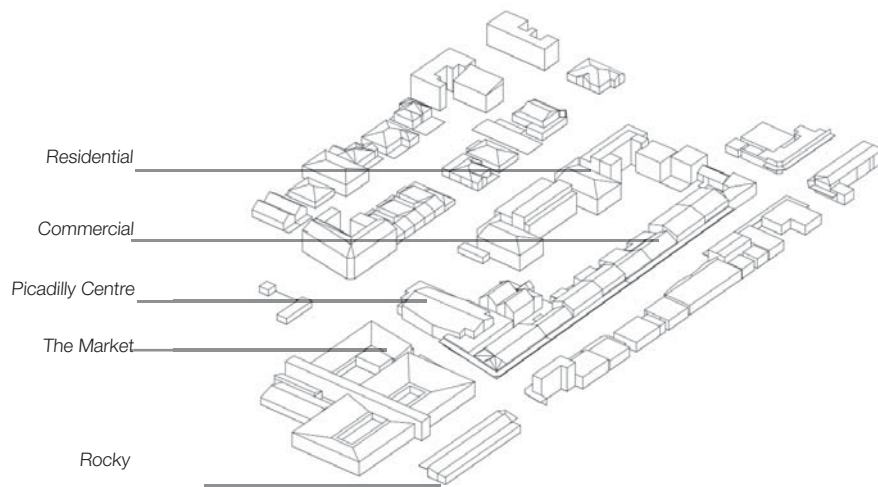

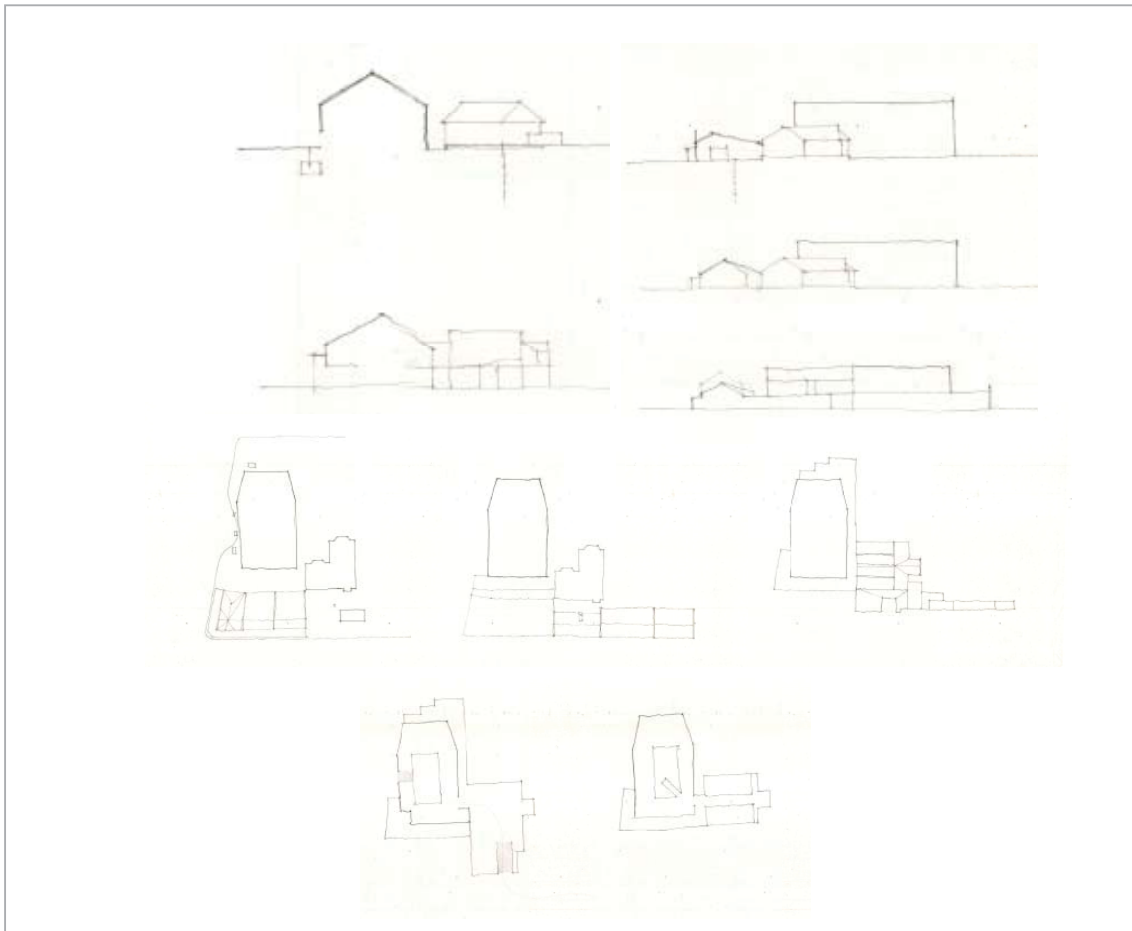

Fabric morphology



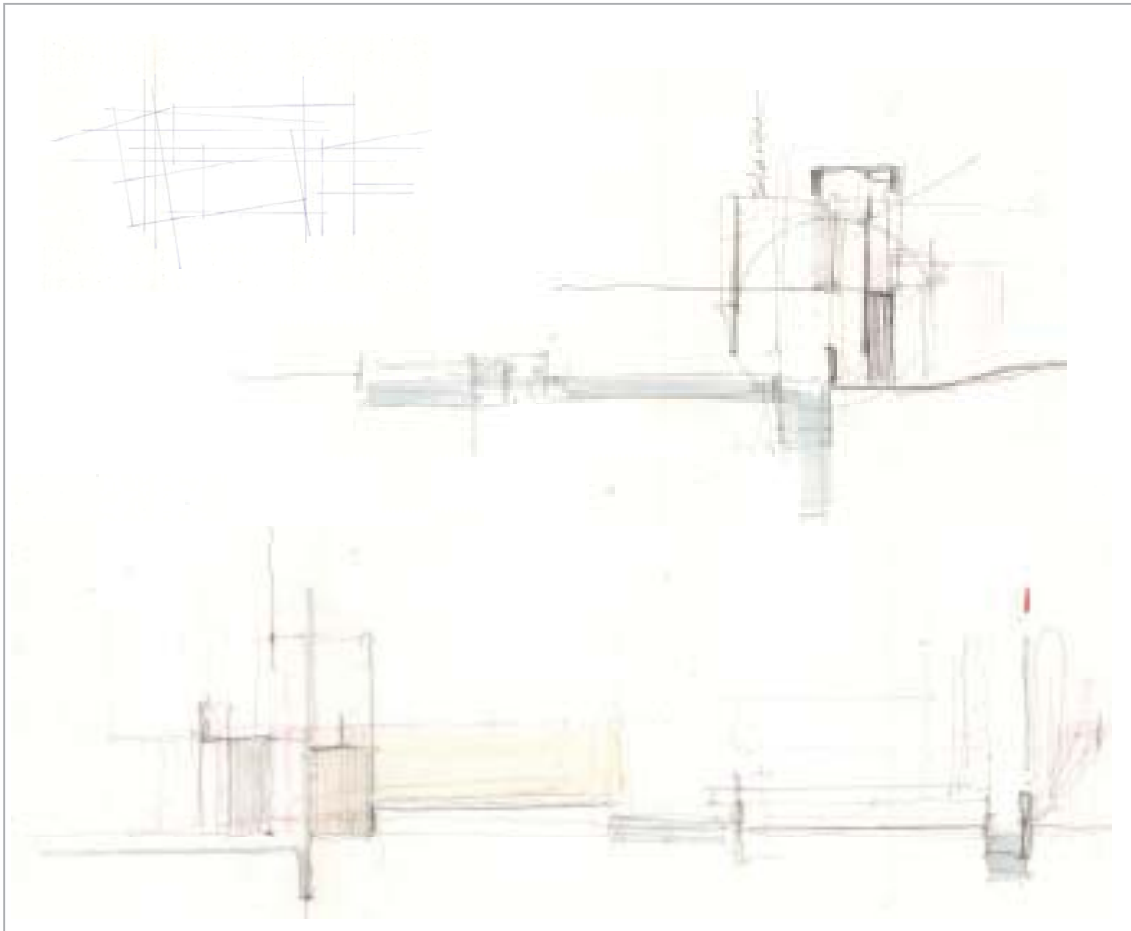

Spatial investigation diagrams





3.3. THE DEVELOPMENT OF THE PARK

1890

The park is one of two public open spaces in the Yeoville/Bellevue area. It is centrally located adjacent to the main commercial axis of Rockey/Raleigh Street in the vicinity of most of the civic facilities in the area.

ASM Architects and Urban Designers recently reconfigured the use of soft and hard surfaces in the park.

The Day Care Centre

The building used to be the Yeoville Clinic before it was relocated to its current location in the park. It is now used by the Siyabathanda Day Care Centre which initially schooled 20 children using the premises of St Mark's Presbyterian Church. Close to a 100 children are currently enrolled. The Day Care Centre is a non-profit community-based facility which benefits by receiving donations from the Gauteng Department of Education

Work in the park commissioned by the Johannesburg development agency (JDA):

Yeoville Recreation Centre

The centre was established in 1961 and further extensions were completed in 1962.

From 1994, the Yeoville Recreation Centre became a multi-facility centre. It is used as a meeting place, a voting station, a centre for learning whereby people from all over Africa learn how to speak English, a music hall and a forum for debate and discussions.

Urbanworks Architects in collaboration with Nsika Architects designed additions to the centre in 2010.

Yeoville Clinic - 1995

The transitional government of the City of Johannesburg commissioned medical facility for community-based healthcare. Paul Schlapobersky Architects.

Library- 2009

An old tram shed which was built in 1924 and used to be a City Power plant that supplied power to the businesses in the Yeoville and Bellevue East area before it was converted into a place for learning and studying.

Police Station - 2015

The station was originally located on the corner of Kenmere and Hunter Street in a house where it acted as a satellite station reporting to Hillbrow.

ASM Architects and Urban Designers.

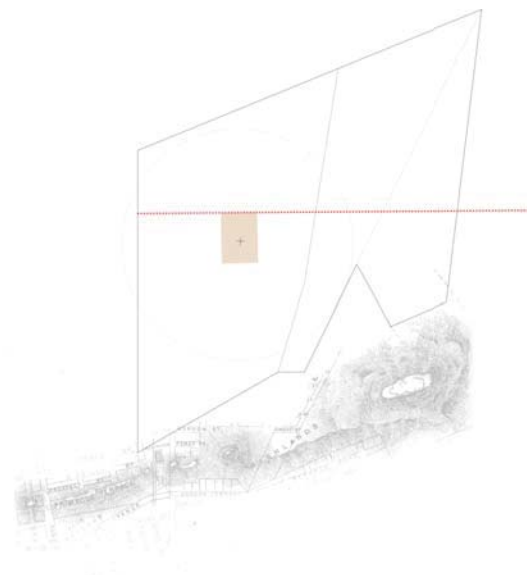



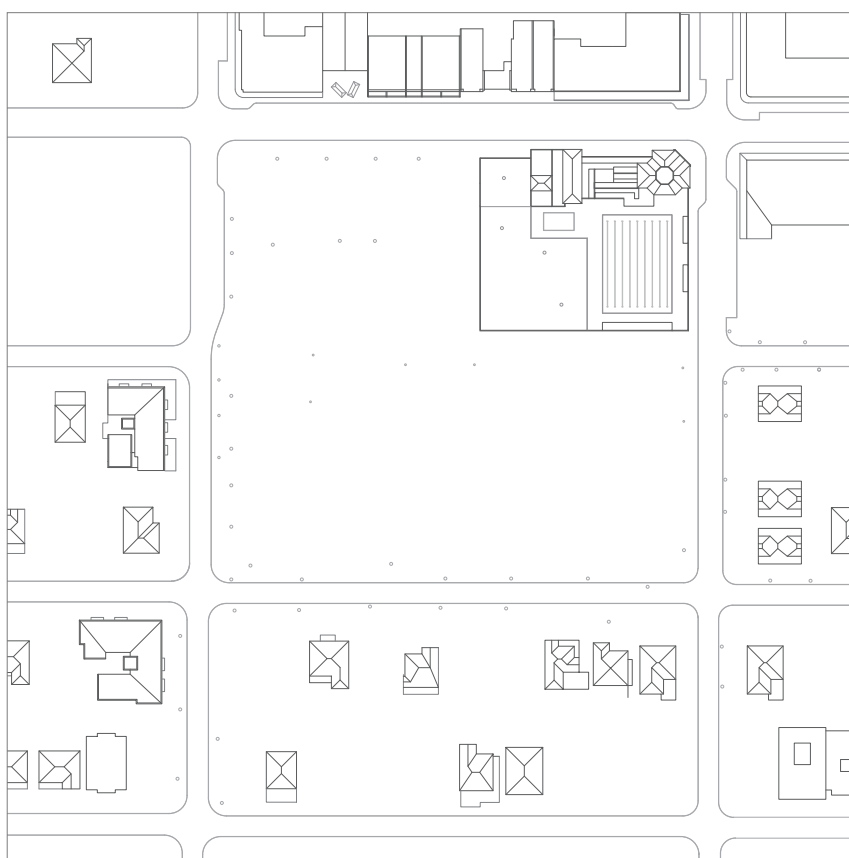
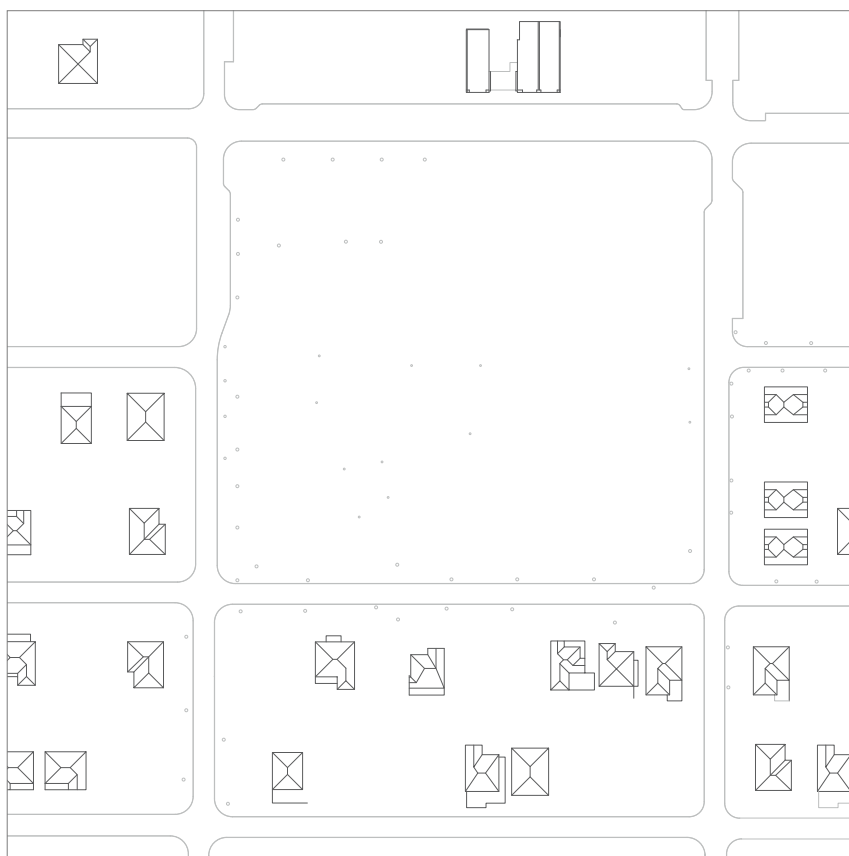

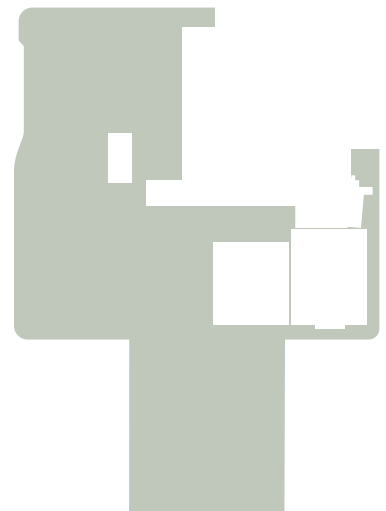

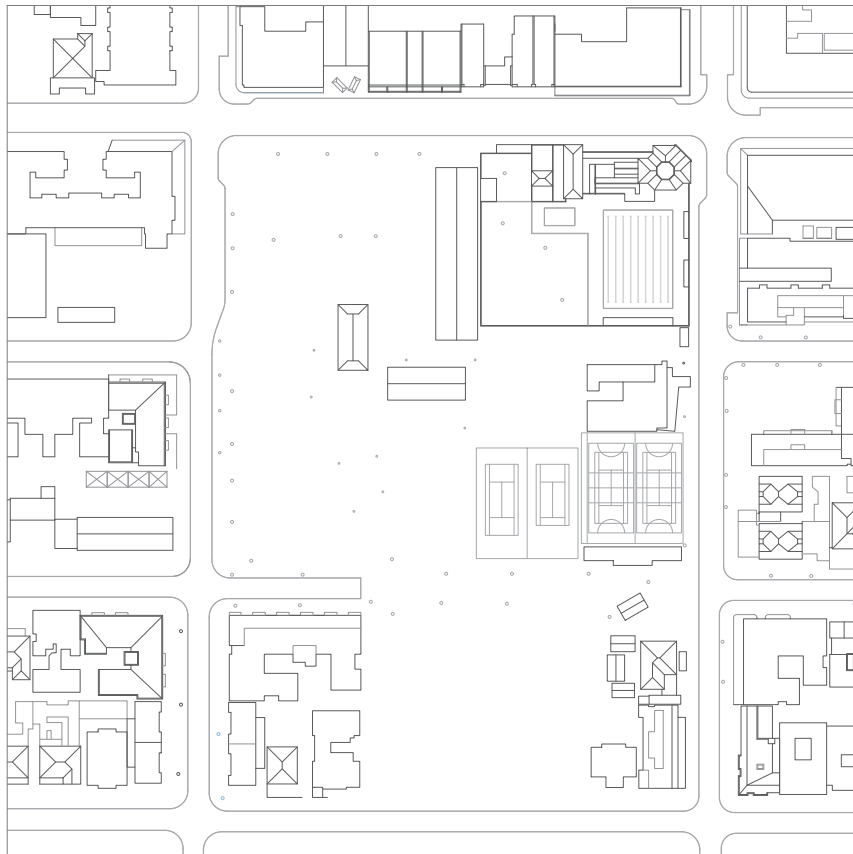
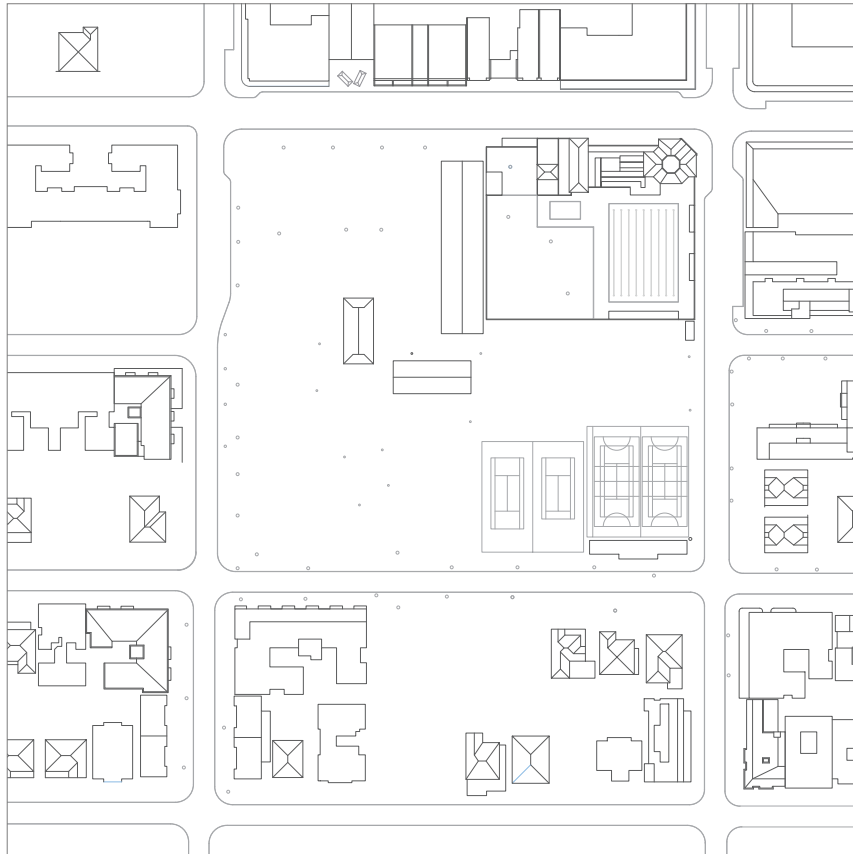

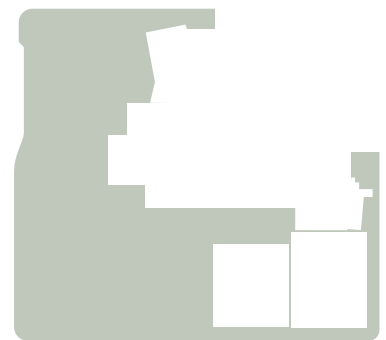
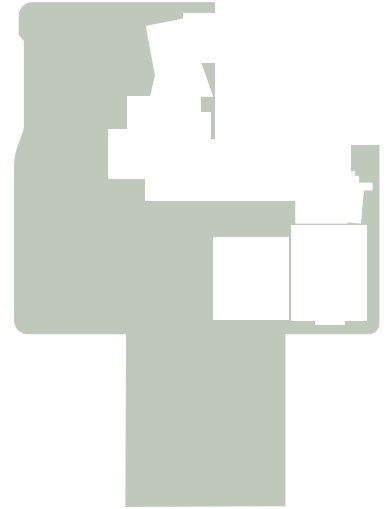

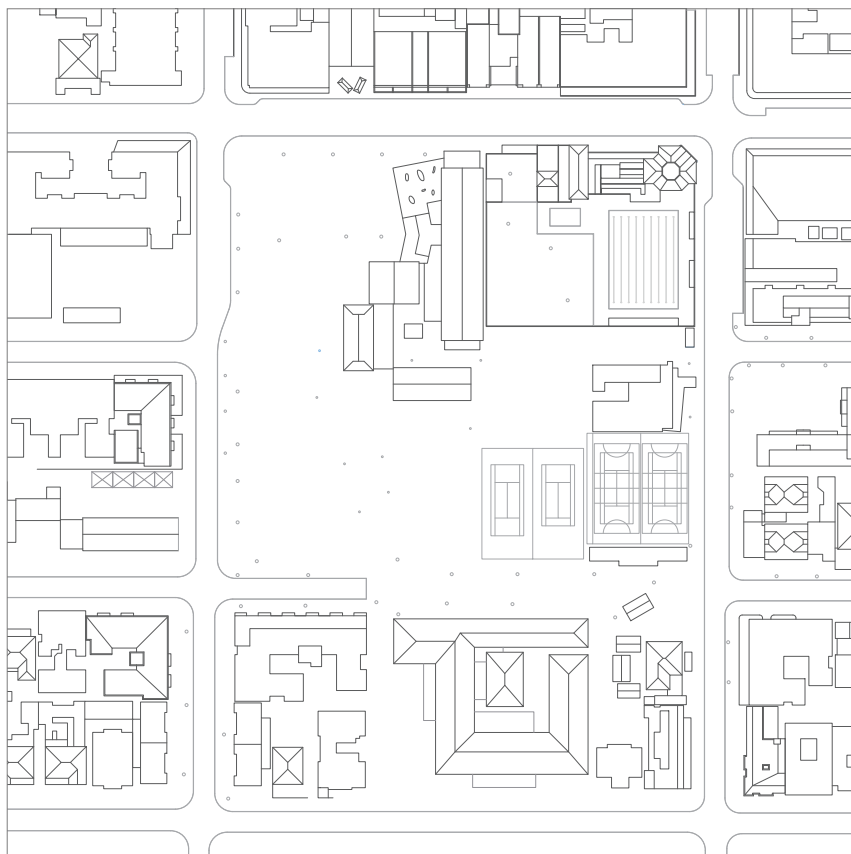
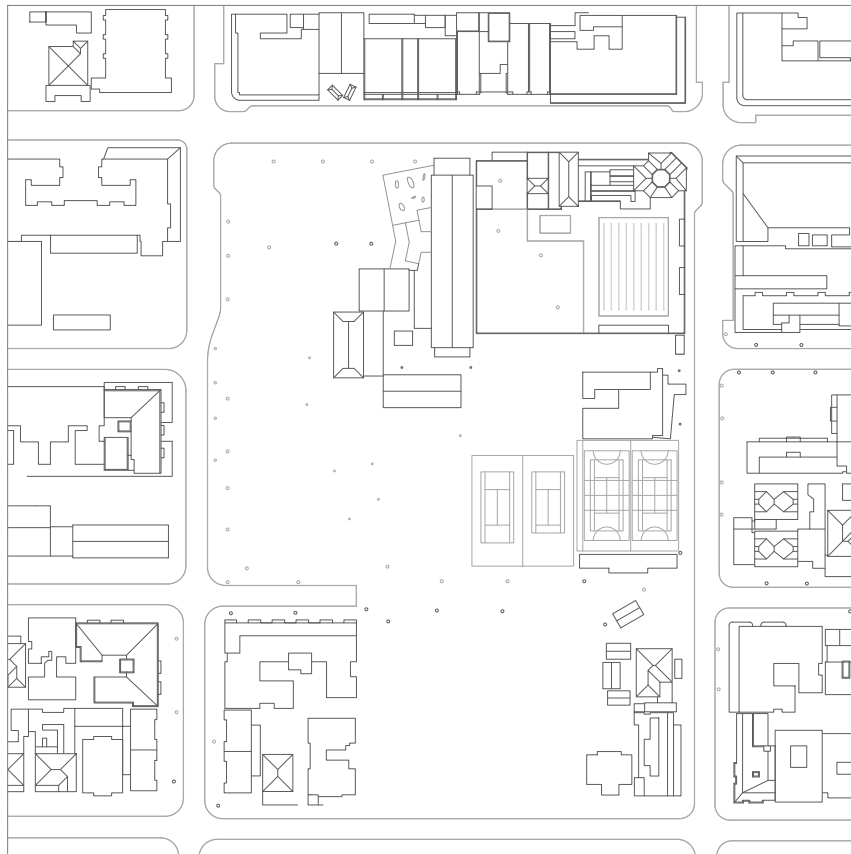



3.3.1. The evolution of the park typology

The Pool makes up a corner of the Yeoville Public Park that was established with the proclamation of Yeoville in 1890. The design will respond to the Pool as well as the park.

The relationship between man and landscape is reproduced in the garden, first as the edge between man and its constructed civilisation and later as the dissolution of the edge and incorporation into the city fabric. The distinction between city and landscape continued up to the nineteenth century, until the modern notion of spatial continuity challenged the dividing line between city and landscape (Aben & De Wit, 1999:142).

The garden first acted as saviour to the condensed and polluted Industrial city at the dawn of the nineteenth century. Where it developed as a park outside of the city, its introduction into the city had to compensate for the landscape which got out of reach and offered retreat from an unpleasant outside world through introverted green space. Low density development is interwoven with expansive collective and private green space in the Garden city. This ended the dialectic between city and landscape and resulted in an autonomous unit of building and landscape that undermined the exclusive status of the garden as the paradise was fractured into repetitive privately-bound gardens (Aben & De Wit, 1999:142). The confrontation between the park and urban tissue is further blurred where the English landscape garden was absorbed into urban morphology. Responding to the natural conditions of place, the urban built development acts as the garden's edge. Void of containment, the park expresses the endlessness around it in the form of pockets of green spaces (Aben & De Wit, 1999:141).

With the emergence of the garden city the first planned suburbs were built in the US. This American counterpart of the garden city fostered the same ideals of intertwining landscape and city, per contra abandoning its contained character, a collective, manicured grass surface flows uninterrupted from one plot to another without vertical hindrance, to create the Collective lawn (Aben & De Wit, 1999:143).

The separate zoning of functions work, dwelling, leisure, transportation, in the progressive industrial city post 1917 meant relationship between buildings and the public park would end. In the garden city the garden forfeited its exclusive character and together with the 'collective lawn' in the American suburbs, lost out on the expansiveness of natural space.

In the thinking of the Modern Movement human activities were divided into functional categories of sleeping, working and travelling and a new programme of recreation. This meant that the public park and the private garden (public urban park and collective lawn) were transformed into people's parks (Volksparken) and functional gardens and came to represent boundless space that invited walks into the horizon (Aben & De Wit, 1999:142).

The functional garden appropriated the ground plane merely a passive support for object buildings so that the definition of the garden is only comprehensible as leisure facility. The ground plane does not lend itself to be spatially defined or multi-interpretable places (Aben & De Wit, 1999:143). In its most extreme form the functional garden is fully integrated into the machine à habiter as the roof garden. Corbusier lifted his buildings from the ground so that nature could continue unspoilt beneath as a social plane and moral arena. Because the ground plane is for everyone the roof or balcony garden, away from the gaze of passers-by, is separated and allows individual activities of sunbathing, playing, conversing and the spatial game of finite and infinite brought into the building (Aben & De Wit, 1999:103).



3.3.2. The enclosed garden typology

The archetype of the enclosed garden incorporates landscape architecture, urban design and architecture to negotiate the divide between architecture and the landscape. In this archetype, the landscape becomes interior, its dimensions tamed and delimited with architectural means and a sequence of space, landscape and the city. The enclosed garden is where the real landscape and the untouched natural landscape meet. In the urban landscape where nature is at once excluded and brought into view by the enclosed garden, a haven of peace and quiet is rendered by replacing the natural horizon with an internal horizon, capturing in essence, by representation or by abstract, the expansiveness of its natural surround (Aben & De Wit, 1999:10). It is thus an intermediary between man and landscape. The design materialises the expansiveness of the landscape in the seclusion of the garden. Man reconciles himself with his surroundings by bringing it within the closest spatial proximity. Its paradoxical character of being infinite and finite heightening each other by being present simultaneously (Aben & De Wit, 1999:14). The horizon-orientated garden and enclosed garden evolved until the garden and horizon coincided in a spatial abstraction. The enclosed garden was then reduced to a category of function and dissolves its character where the landscape and space are no longer conceived in terms of their differences but their functional value.

Urban landscape and enclosed garden

The landscape is no longer the unambiguous natural or rural counter-form of the city and is getting more and more woven with the city and absorbed in a diffuse urban landscape. This new relationship between the landscape and the city is able to find expression in the enclosed garden. The garden can be as much as an Arcadian counterpart as a representation of the city, or possess one of the much more complicated intermediate forms. Gardens are likewise an expression of the image we have of nature today. In a world that is becoming more urbanised by the day the wilderness has come to represent paradise. The classic concept of nature as counterpart to culture or cultivation has split into two complementary notions: The unspoilt fragile nature of paradise, beyond the sphere and influence of the city and the unstoppable power of the urban machine (Aben & De Wit, 1999:154).





3.4.1. The Swimming Pool Typology

Swimming is traditionally a military skill encouraged by Eighteenth century Sea bathing. It developed into a competitive sport in the nineteenth century when laned pools provided more suitable conditions for racing than the open sea. In recent decades, the competitive element has been supplemented by the provision of leisure pools that simulate the enjoyment of seashore conditions and other natural water bodies with wave machines, chutes and flume rides (Wylson 1987:16).

As an architectural type the pool is easily defined by its use of swimming and playing. Its simple form retains its contents - a natural element which on the contrary is highly complex. While the pool allows intellectual wanderings and stirs the imagination, its recognisable form as an architectural object allows its wanderer to resume the thread of acquaintance where it was last left at (Van Leeuwen 1998:7).

The pool is the architectural outcome of the man's desire to become one with the element of water, privately and free of danger (Van Leeuwen 1998:2). A swim in the pool is a complex and curious activity, one that oscillates between joy and fear, between domination and submission. When a swimmer delivers himself to the forces of gravity, the sensations of weight- and timelessness contribute to the rationale of joyful swimming. The limitless and unbounded nature that attracts swimmers to water also produces a somewhat exalted feeling of oneness with the natural environment (Van Leeuwen 1998:16).

The unbounded nature of interaction with water contributes to understanding of the swimming pool as utopian spaces. The physical frame of the pool has been used to enforce fantasies of social differentiation and hierarchies based on ideas of gender, age, class, race and sexuality throughout history. However, in Europe and North America where urban development driven by industry-based economic growth responsible for deplorable living conditions of the poor, the development of the public pool advanced progress to an equal society in public space (Wylson 1987:72).

The Lido movement in England

Public baths and wash-houses in England were originally spatially organised along class and gender lines, with male-only participation dominating their use. In 1925 the Public Health Act legislated that baths could be closed during the winter months and used for other 'healthful recreation' (Pussard 2007:178). Swimming therefore fitted with the rational recreational ideals of a 'healthy body, healthy mind' that emphasised cleanliness and regulated bodies. Lidos or open-air swimming pool facilities emerged to alleviate the workforce of objectionable living conditions in an urban industrial population where enforced segregation along class and gender lines of bathing and swimming later declined. As a part of a recreational movement, lidos were designed in urban parks, encouraging a less regulated and more self-indulgent swimming experience. They were ambiguous spaces in urban centres that resembled halfway houses between town and country (Pussard 2007:179).

The Public Swimming Pool in New York

Public swimming pools featured prominently in the vision held for the modern city when the New York City Department of Parks, under the guidance of Robert Moses, envisioned radical urban renewal to counteract the effects of The Great Depression (Gutman 2008:553). These and other spaces for public recreation was embraced by modern architects eager for change in Harlem, Brownsville and other neighbourhoods faced with economic adversity and undergoing demographic change. The pools were new spaces of public informality that offered equal access to outdoor recreation. The pools built by Moses were not always intrinsically free from racial segregation but in this case modern architecture was key in shaping a better social world. In magnificent new places, imagined by a conservative park commissioner, play mirrored reality and reflected the state of society and the government. At public pools in New York children cut across boundaries through play, progressing the growth of democratic civic space (Gutman 2008:554).

"The pool is a mirror of society, a place where we, like Narcissus, can admire ourselves and where the real and the unreal mix. It represents the very edge of possibilities, since it is both a man-made artefact and something that cannot be contained by man. The pool is where architecture becomes a mirror, a frame that does not contain the possibility of a perfect world, but reflects the world all around us back to ourselves. We can only frame water here and dream by looking into it." Betsky (1995:13)



3.4.2. Water and Architecture

Water can be in different states of sanctity. Swimming pools, ponds, puddles or deep spots in a river all demand various states of respect and awe. (Van Leeuwen 1998: 7) The use of water in architecture include the notions of water as a continuum of the universe made real, as a source of life and rebirth or a mirror that creates a heterotopic alternative to lived experience (Betsky 1995: 8). Where architecture is synthesised with water in a utilitarian, symbolic, therapeutic, leisurely or visual context these mythic dimensions inform the use of water in architecture but are not contained by them. When fountains try to embody these mythic dimensions, they are only illustrative leaving the true power of water to overwhelm their stories with splashing delight or nourishing drinks. (Betsky 1995: 8)

Within the realm of the man-made environment water removes itself from the speculative mythical realm where it is pure and inaccessible to become a representative or structuring element. (Betsky 1995: 13)

1 Representative – connecting

Buildings remove us from nature, by sheltering us from it and creating a new rational and human realm in its place and water has the potential to reconcile the divide. At the Alhambra and gardens of the Generalife water is an element of construction that heals the irreparable wound created by the very act of building (Betsky 1995: 8). This is possible not because water is an imitation of its natural equivalent but as a fragment of it that continues the architectonic qualities of water. At the Alhambra water is a spatial element - a narrative of connecting channels and pools that guide you through space. Where the heat is softened by ephemeral water rather than being cut out by walls, water weaves together rather than creating distinctions between inside and out. The Islamic view of Paradise includes a garden of delight. Here a sensual play between water and the architectonic qualities of water connect to become the new Eden complete with cool spring and fountains surrounded with plant life whose presence flows from the water (Wylson, 1987:156).

2 Structuring – development

Water can be an element that develops the character of the built environment in economically logic ways (Betsky 1995:12). In some places water is so integrated into the built fabric that it cannot be distinguished from the built for. The Netherlands of the fourteenth century, and in particular Flanders, converted a rising tide in a swamp where the river faded into the sea, into a total urban environment for maritime trading and commercial activities. It is arguably an art of representation that essentially develops control of nature (Wylson 1987:41) with the virtue of being as real and changeable as water itself.

Water in the contemporary urban environment

The presence of water in the contemporary urban environment has become hidden. Technology obscures the true nature of water when it is recreated it in such a way that it can be controlled, distributed and turned off at will. It exists in sewers, tunnels and reservoirs and bubbles through the surface where urban inhabitant's interaction with it is limited to the tap, sink or shower. Cities develop in amorphous patterns that defy the presence of water yet demand it all the same time with little to no trace in its man-made environment of its vast systems of extraction, purification, distribution and drainage (Betsky 1995:13).

The history of its uses have become hidden so that water now only appears as imitations of itself. The Office of Metropolitan Architecture's Floating Swimming Pool sits on the opposite pole of Betsky's (1995) representative and structuring water architecture. Adrift in the ocean, the pool purifies and converts water into a pleasure and a moving ritual of regulated swimming. The mythic dimensions and spatial opportunity of water no longer satisfies the act of leisure and the demands of what its function has come to present. The pool is the essence of modern architecture - "[...] a structure floating in a sea of desire." Betsky (1995:15).

The swimming pool, Rem Koolhaas, New York, USA, 1977

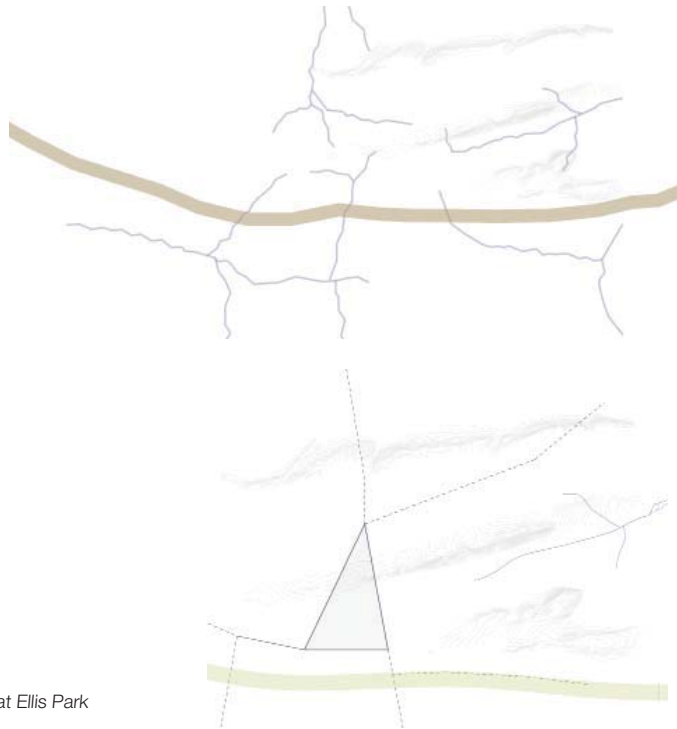

Early reservoirs and lake at Ellis Park

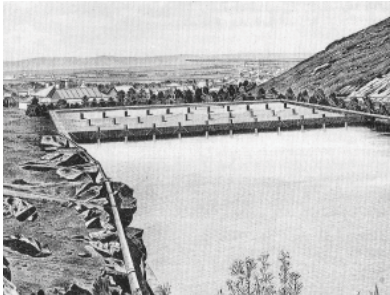

The reservoir at Seratoga Avenue





3.4.3. Water in Johannesburg

The Witwatersrand owes its name to the waterfalls that drop down from the ridge running east west from Krugersdorp to approximately Bedfordview. The Witwatersrand forms a watershed between the Atlantic and Indian Ocean with a shear drop on southern boundary to Yeoville (Fisher 1989:67). Before the discovery of gold the surrounding farms took their names from local springs (fontein in Afrikaans). The suburbs of Johannesburg would later adopt these names - Braamfontein is the spring by the brambles and Doornfontein, the spring by the thorn bushes (Malcomess & Kreutzfeldt 2013: 48).

Water was initially supplied by private companies to Johannesburg's growing population. Barney Barnato acquired the concessions for water that was granted by the Volksraad in 1889 and set up the Johannesburg Waterworks, Estate and Exploration Co. Ltd. A dam was built close to the oldest water fountain that provided drinking water to the miners. In 1888 the spring that originates in a small kloof near the later Harrow Road on the Bezuidenhout Farmstead was dammed to provide drinking water for the miners and subsequently a reservoir was built where Ellis Park is today (Meiring 1985: 87). From where water was pumped to the city's first gravity fed reservoir on the corner of Harrow Road and Serratoga Avenue. (Malcomess & Kreutzfeldt 2013: 48)

Malcomess & Kreutzfeldt (2013) argue the lack of visible water source in Johannesburg. The image of water, or in case the absence thereof, reflects the risk, uncertainty and fantasy of the city's subterranean origins in mining and those who do not own it. It contributes to the unnaturalness of the city, and now threatens the invisible underground water that accounts for the spruits that run deep below its asphalt grid.

1890 Berea – Harrow Road Reservoirs

1905 The lake at Ellis Park (Norwich 1986)

1909 Water tower (Yeoville's water tower is considered a bizarre and unique structure in South Africa (Meiring 1985: 87).)

Yeoville Reservoirs

1909 Municipal Swimming Baths (Norwich 1986)

Summit Club

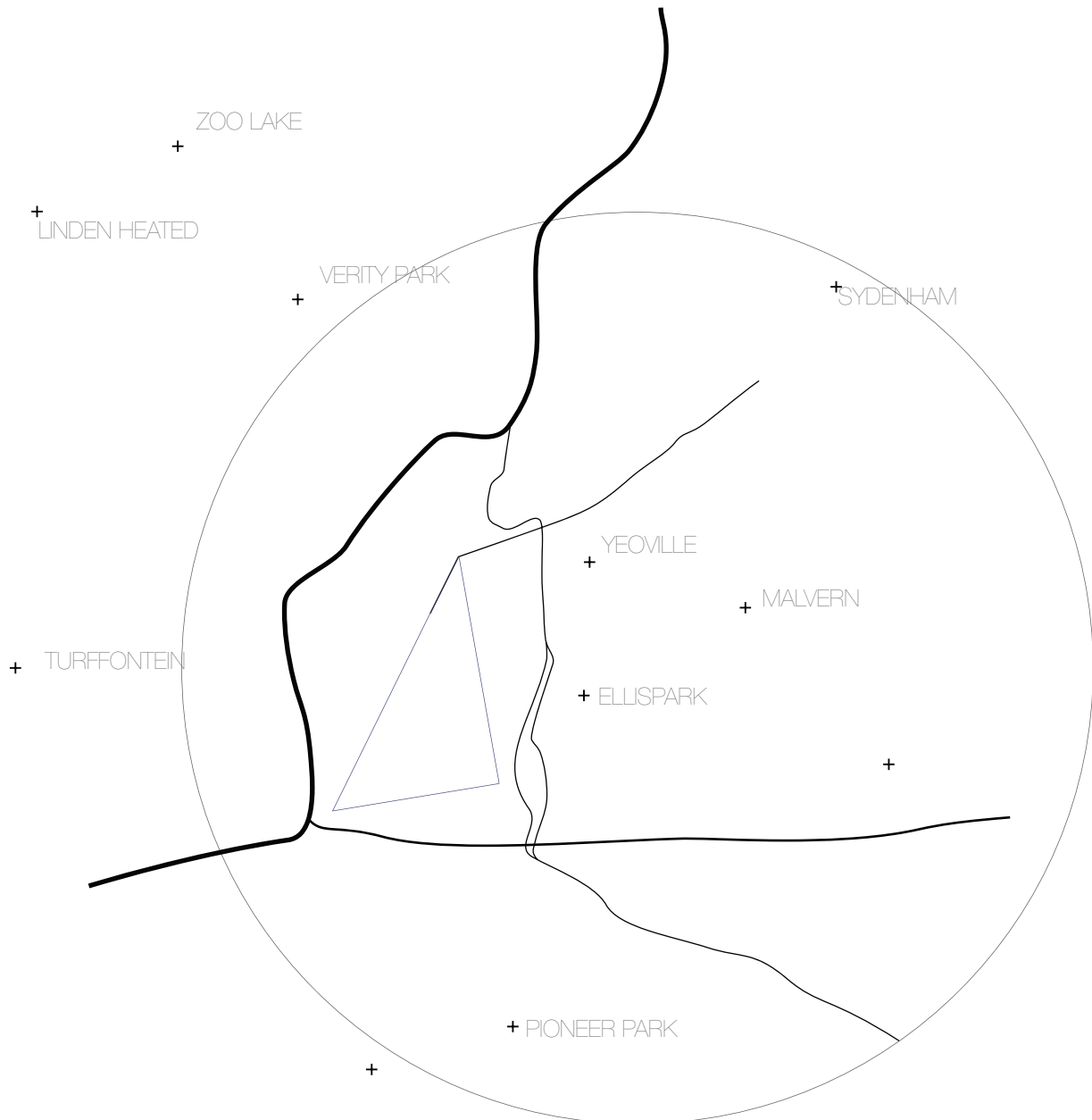

Mapping Public Swimming Pools in Johannesburg

The CSIR published the Guidelines for the Provision of Social Facilities in South African that provides a quantitative and rational framework for the provision of social facilities for various levels of settlements to support the planning process and provide support to social facility investment plans. Under Classification of Settlement from Table 1 (Green & Argue 2012: 11) Johannesburg is classified as a type A in the Hierarchy of settlements. As a metropolitan city region with a

catchment size greater than a million inhabitants. Under Recreation Provision (Sports and Parks) a Swimming Pool Complex (25 m to 33 m pool) is compulsory for the Average Threshold (population) of 80 000 inhabitants within an acceptable travel distance (km) of 5 km - 10 km. A swimming Pool (50 m pool) is compulsory for the average threshold (population) of 500 000 – 1 000 000 inhabitants within a variable/undefined travel distance. The provision guideline accounts for density (population per land area). (Green & Argue 2012: 28)

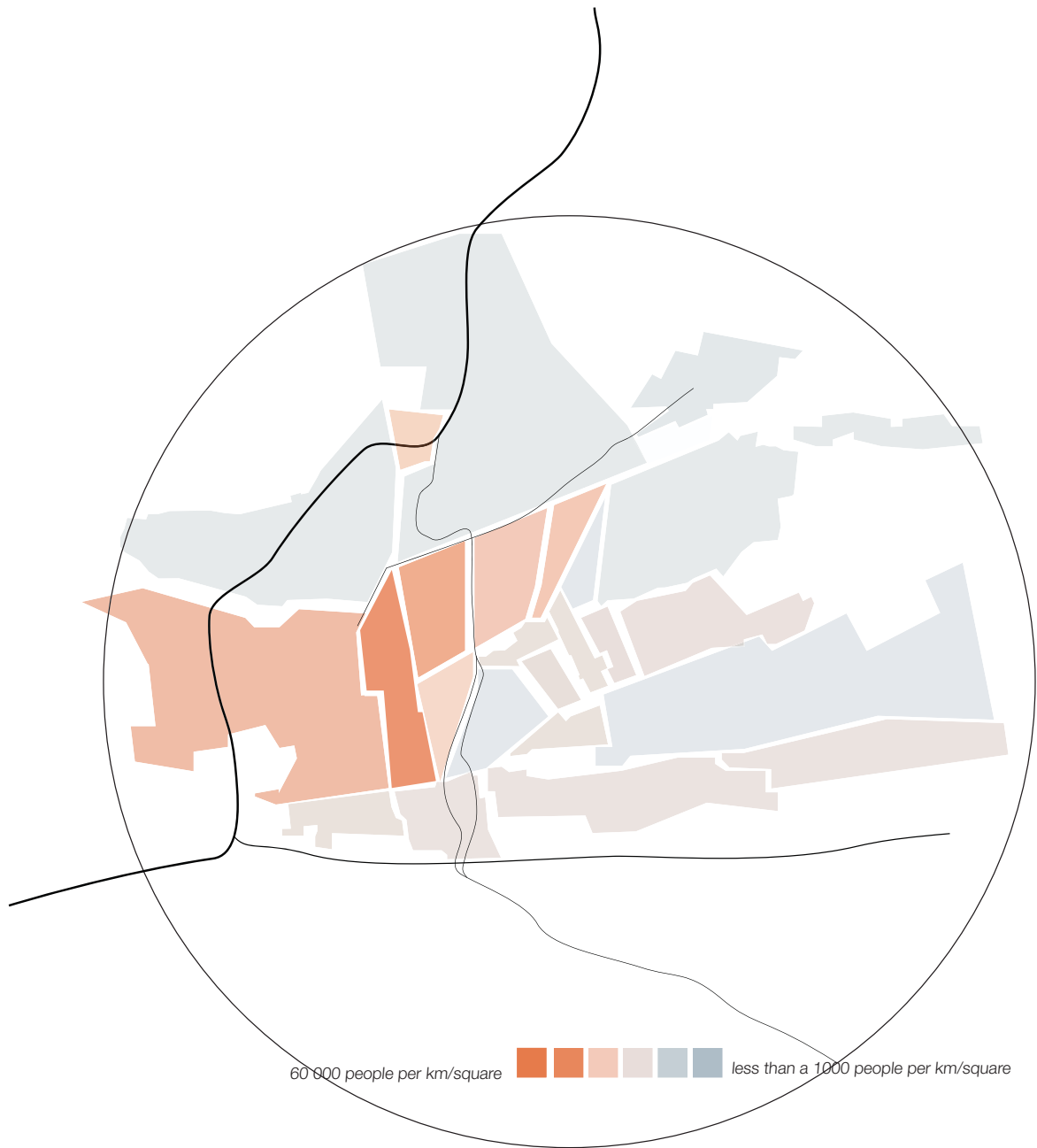



3.4.4. Water in Yeoville

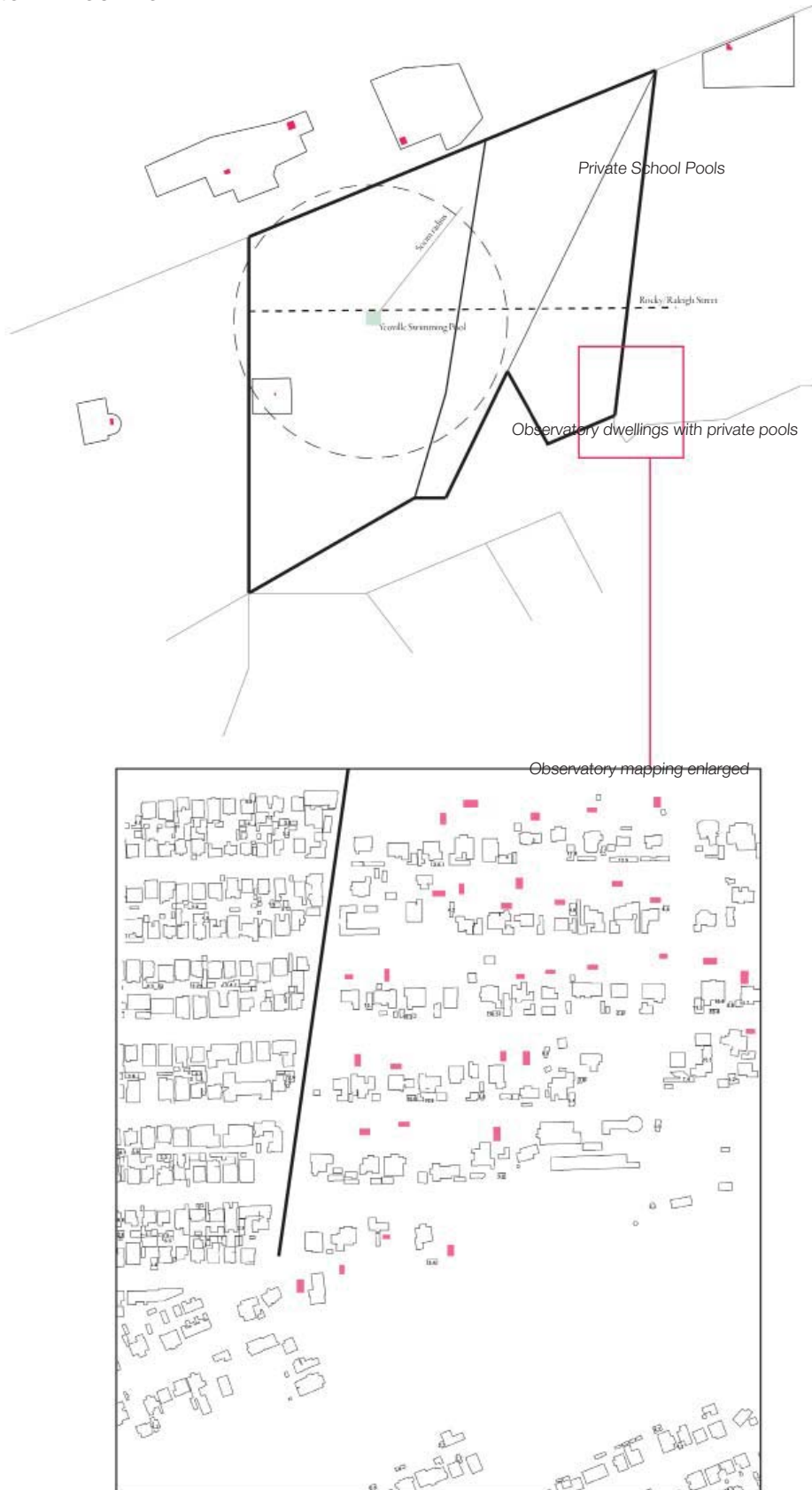

Mapping pools in the immediate vicinity



3.5. NOSTALGIA IN THE URBAN LANDSCAPE

The urge to somehow fix the landscape seems an expression of nostalgia. An attempt to hang on to a past is also the act of registering changes against the backdrop of a changing context. To expose the layered condition of the landscape we need only take one layer, the landscape as it is today and distil from it a fragment. This allows us to visualise the process of change in the landscape as a whole (Aben & De Wit, 1999:181). As a reworking of context the garden creates its own context through an architectural composition that summarizes the nature that it incorporates (Aben & De Wit, 1999:37). In the enclosed garden the progress of time is irrelevant. Eternity and the moment coincide. Linear time cedes to cyclic time. Static space materialises stationary time.

In Summary:
The development of our relationship with the natural landscape in the urban environment

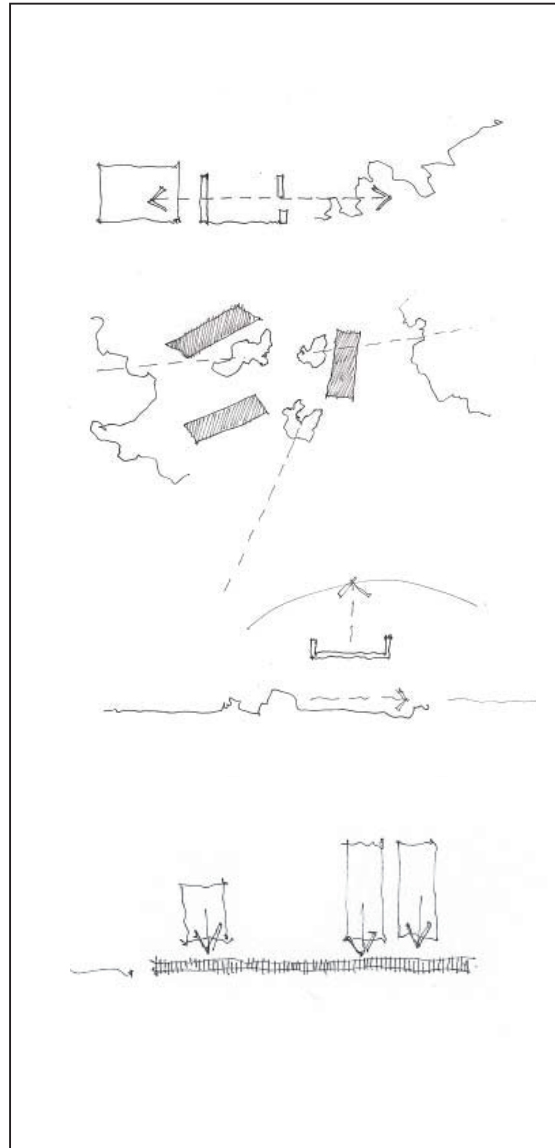

PRECEDENTS

To further explore the relationship between built environment and natural landscape:

Unité d'habitation Cité radieuse, Le Corbusier, Marseille France, 1947-1952

If the functional garden is a limited domain in which nature is manipulated, the garden wall is neglected or with a grand gesture accommodated the whole world within. Where the enclosed garden once represented the world, the whole world had to become the garden. At Cité radieuse the rooftop becomes the roofscape, a functional plane that substitutes the building's relationship with its natural landscape with a social platform composed of leisure facilities and spaces that includes a nursery, running track, gymnasium, solarium and pools for paddling and swimming.

At Villa Savoye the relationship between man and nature is also taken on by the building without the intercession of a garden. The house is a free standing object on an untouched landscape. The free forms of the garden on the roof plane further detaches it from the house.

The German Pavilion, Ludwig Mies van der Rohe, Barcelona Spain' 1929

In the instance of the German Pavilion the enclosed garden is not a go-between but as a means of anchoring a centrifigural and continuous composition where inside and outside is intertwined. Typifying the sequence of the landscape, pavilion and patio sequence is a constant reversal between the absence and presence of context. The patio at the Pavilion is an inversion of the enclosed garden. Exterior space is condensed into the enclosed patio, the only space of the Pavilion that completely shuts out its surroundings. Movement in the space is restricted to the narrow strip of the gallery. The closed box with three walls and gallery is a static frame with a female statue placed off-centre, giving a vertical axis to the introverted space. The statue draws attention to the sky above and her reflection in the water below. The patio is motionless and timeless. Through its abstraction of form and material it is also a void that transcends the limitations of the rectangle.

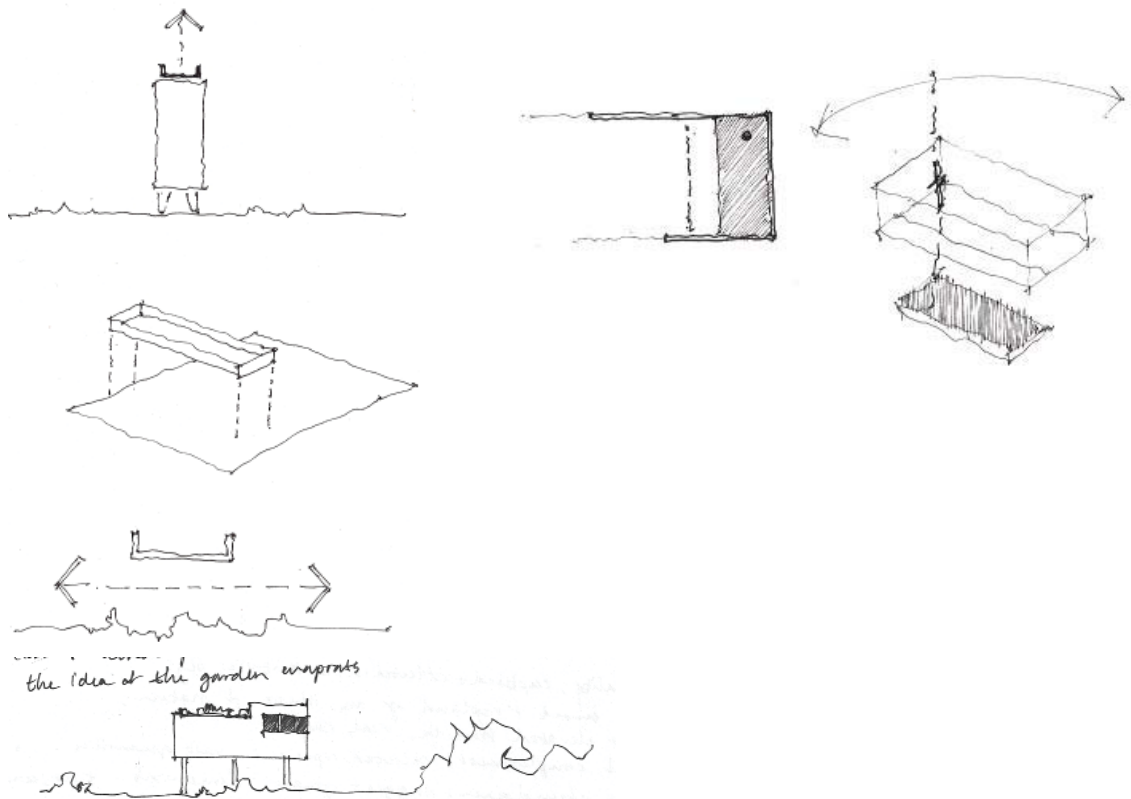

**Louis-Jeantet Research Institution,
TER Landscape Architects Geneva
Switzerland
1993**

A sunken enclosed garden responds to urban infrastructure while revealing the historical layers of its context through spatial composition. The garden is the entrance to a new underground auditorium of the Research Institute. It is enclosed by two interlocking channels with a ramp poking out of the garden wall with a dark cave like opening as the only way the auditorium and the garden reveal their presence to the city. The garden is a decompression chamber that filters the sound of the city, reduces its speed with an abstract representation of nature with water trickling from the top of the interlocking channels. Its lowered ground plane renders it a spatial inversion of the existing villa and the auditorium takes its own place on the formal and linear series of street – garden – villa with an acute angle that intersects the garden.

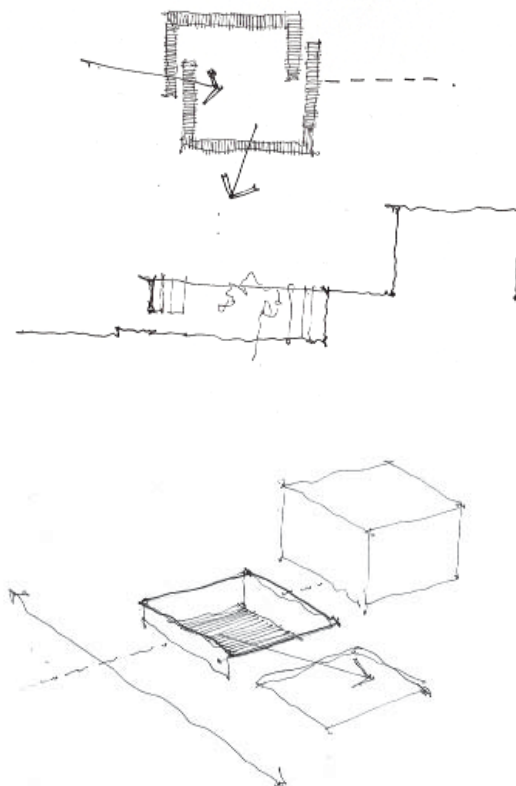

**Leça Swimming Pools,
Alvaro Siza, Leça de Palmeira Portugal
1966**

The horizon of the natural landscape of the ocean is fragmented into rock pools that contain and simulate their greater environment. The abstraction of the landscape, a process of scaling that brings the limitless horizon into reach, transcends the manmade boundaries of the pool to an ironic tactile reconciliation of man and nature.

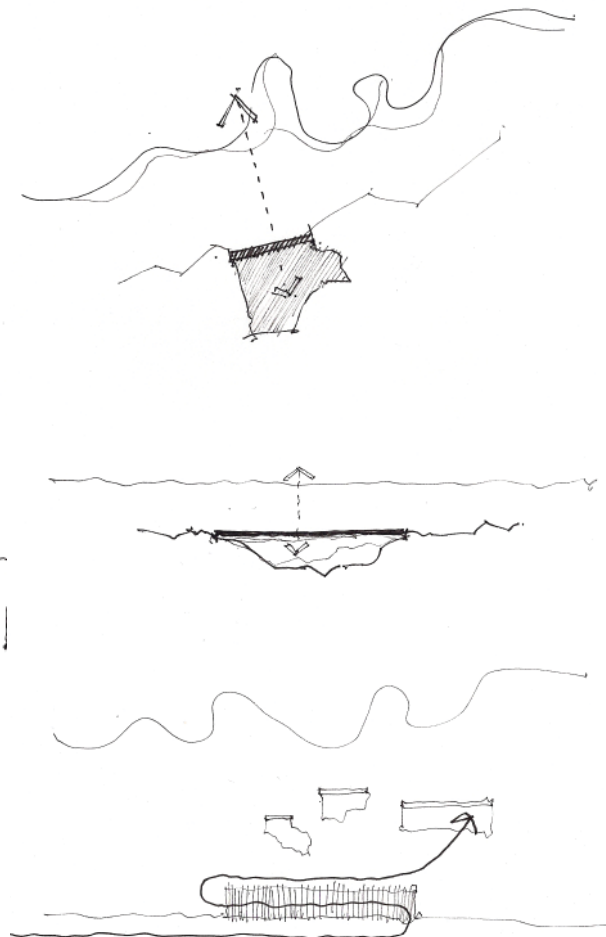

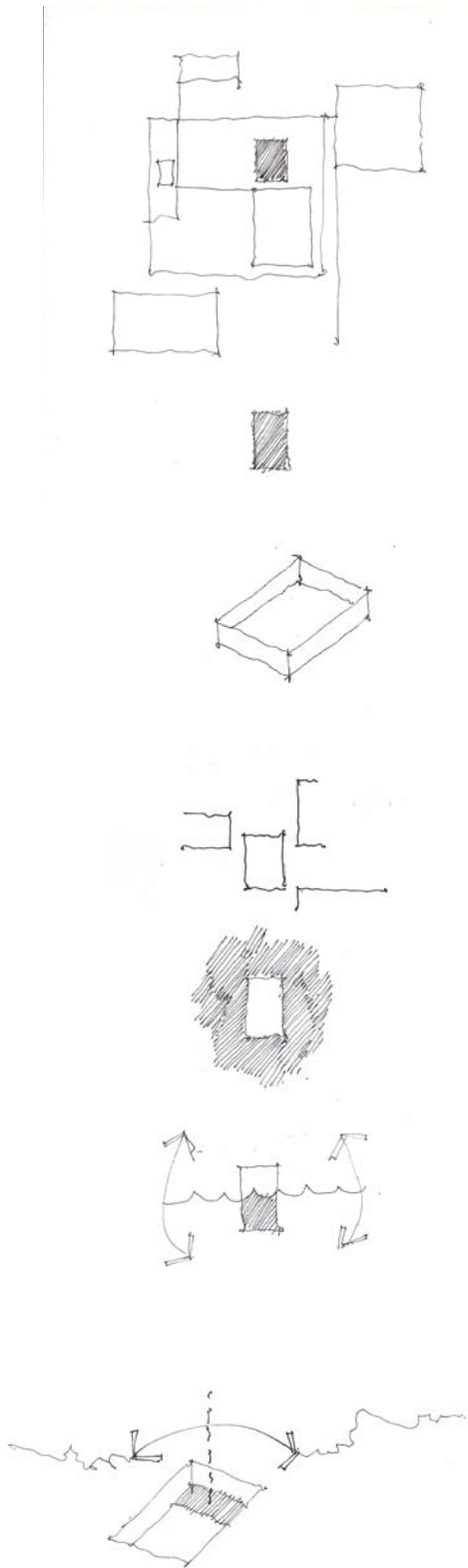

Fragmentation is an inherent condition

Fragments have physical and non-physical edges

Fragments with physical edges in the city can introduce new spatial typologies for urban public space

The nature of their edges isolate them from their immediate environment

If they contain a natural element, a fracture thereof or an abstraction of a natural element, these spaces can reconnect urban inhabitants with their natural environment

A swimming pool is an example thereof and also acts as a social condenser. Through the act of play with the universal element of water, it transcends non-physical boundaries and becomes a valuable artefact to unravel the socio-political climate of a place.

INTERMISSION 3 A SYNOPSIS OF THE STUDY

