

CHAPTER

07

This chapter aims to analyse and interpret the conditions of the site. The concept and development of design is part of the investigation of the original intentions.

SEEKING REFUGE

7.1 KEY CONCEPTS

The informants of the design development is grounded in the ideas of power relations, identity and representational space introduced in Chapter 5. The architectural intentions of the proposed structure has been established to be that of refuge, protection and development.

The following section aims to present the interpretation of the site, iterations of design and how theoretical ideas have evolved into design and structural concepts.

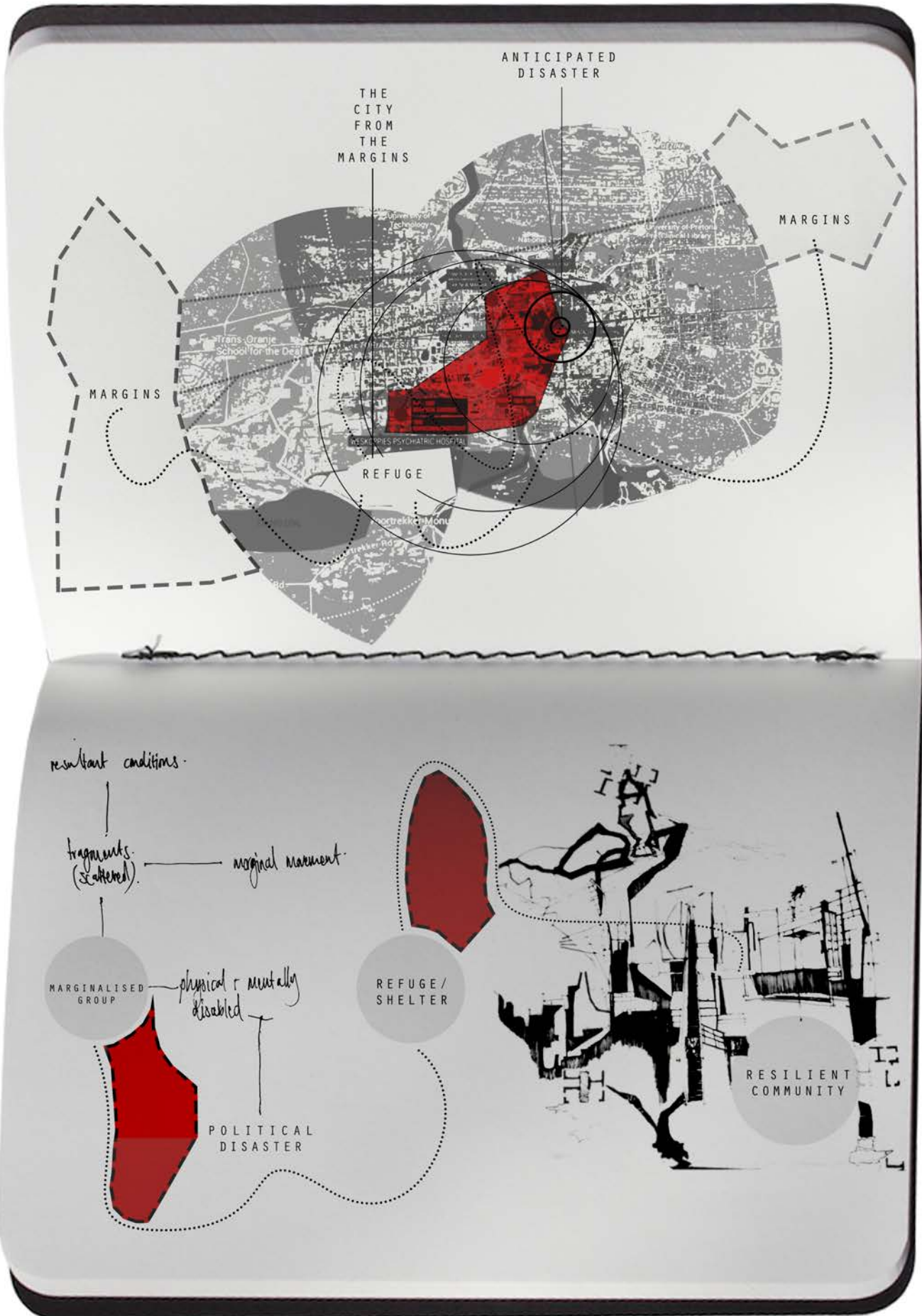


Figure 98: Contribution of the dissertation. (2016)

7.1.1. CONTRIBUTION

The contribution of the dissertation is firstly to deal with different marginalised groups, understanding their potential in the greater scheme of society and recognising them as strong identities rather than 'outcasts'. Secondly, the scheme deals with the concept of refuge in a narrative where disaster takes place. The act of refuge itself suggests the protection of specific resources for preservation (humans and other elements) to rebuild a new society post-disaster. Thirdly the scheme recognises that the structure presents the potential for future scenarios. The outcome of the first scenario may be that the entire structure and the surrounding site becomes a resilient community which can operate on its own through alternative energy sources and the cultivation of new resources. The outcome of the second scenario may be that the structure is left as a ruin in the landscape and that the marginalised people have been accepted back into society on an equal level (in relation to the norm). The third scenario may suggest that the position of the structure becomes the core of the new city and ultimately manifests a new society based on alternative power relations. The marginal community is thus an example of how a new society may function after the disaster - off the grid and completely independent.



Figure 99: Google Earth image of proposed site. (Google Earth 2016)

7.2 SITE: AN INTRODUCTION

The heritage component of this proposal lies in the historical location of the original botanical gardens of Pretoria. The 'Langeberge Ridge' is an untouched natural piece of heritage with a range of plant life and geology yet to be explored and interpreted. The aim is thus to expose the potential of the site through activities of collection, preservation and study. By way of method through the characters of the narrative, each category of people has inherent skills and potential. Skills are then used to unlock the potential of the site as a proposed future sanctuary for the marginal community. Not only will the identities of the marginal community be developed and established, but the protection of the users is of utmost importance. Therefore, the building proposal comprises of elements of robustness with the potential to be developed further by the people that inhabit it.

The ridge is set within a context of multiplicity. The surrounding functions are illustrated in Figure: . The site is further interpreted in relation to boundaries and physical thresholds. Although the structure develops in isolation on and within the ridge, it aims to rehabilitate and restore what has been excavated. The existing plant types found on the ridge are reintroduced on soil that is placed on roofs.

The three reservoirs on the site are part of the Tshwane Water and Sanitation Bulk services for the West of Pretoria and provides water to the surrounding areas. In the context of the dissertation, it is assumed that post-disaster these reservoirs are left for ruin and so in the proposal ownership is taken by the marginal community of these structures as a viable resource not only for water but for the potential of energy generation.

7.2.1. INTERPRETATION AND ANALYSIS

The context is seen to be surrounded by various contested layers of zoning. With industrial sites to the south; memorial sites to the east and south-east (Magazine Hill, Freedom Park and Voortrekker monument); and rehabilitation and military sites to the immediate north (See Figure:). The site can thus be seen as a natural island surrounded by many resources for construction, water services and the idea of memory. These resources are considered in the making of place as well as the structural and environmental concepts.

Key considerations in the development of the site is to use the ridge as a place to observe (without being seen), to collect artefacts of the surrounding landscape, to use the reservoirs as a source of water and energy and that access would be from the south to use the existing roads and pathways already established on site.

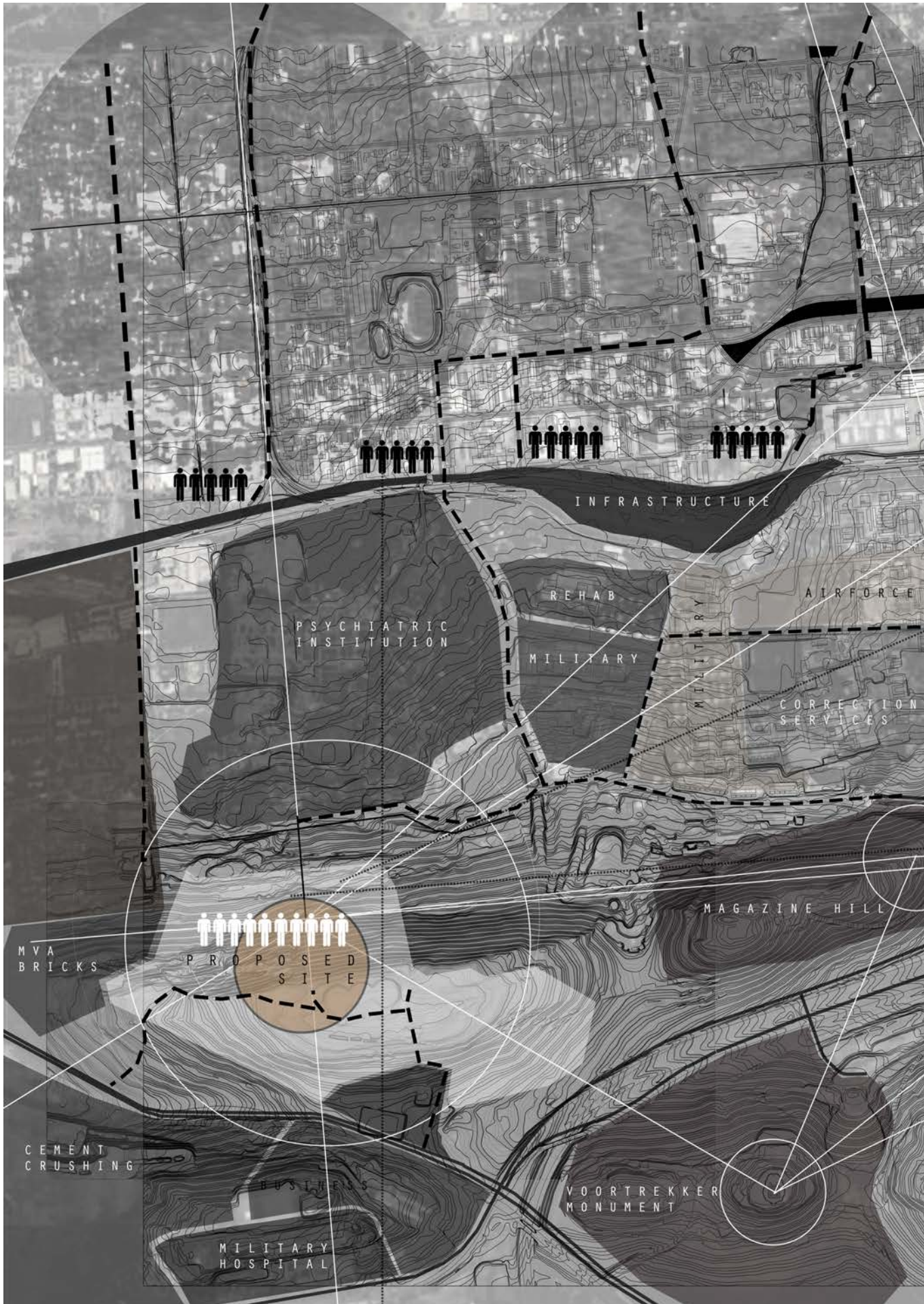


Figure 100: Mapping of surrounding areas and intangible links to other ridges in the vicinity. (2016)





Figure 101: Mapping of surrounding areas and zones in the vicinity. (2016)



7.3. PHYSICAL CONTEXT

7.3.1. RESOURCES

The proposed timeline of the intervention suggests that the architecture develops from a present condition to a future condition. The context presents sites of resources to be used in the construction of the proposed structure. Crushed concrete from the Econoslag Crusher plant is used for cast-in-situ components; and paving bricks from the adjacent MVA Bricks site are used for pathway surfaces between the different structures as well as precast concrete barrier kerbs used for exposed vertical surfaces.

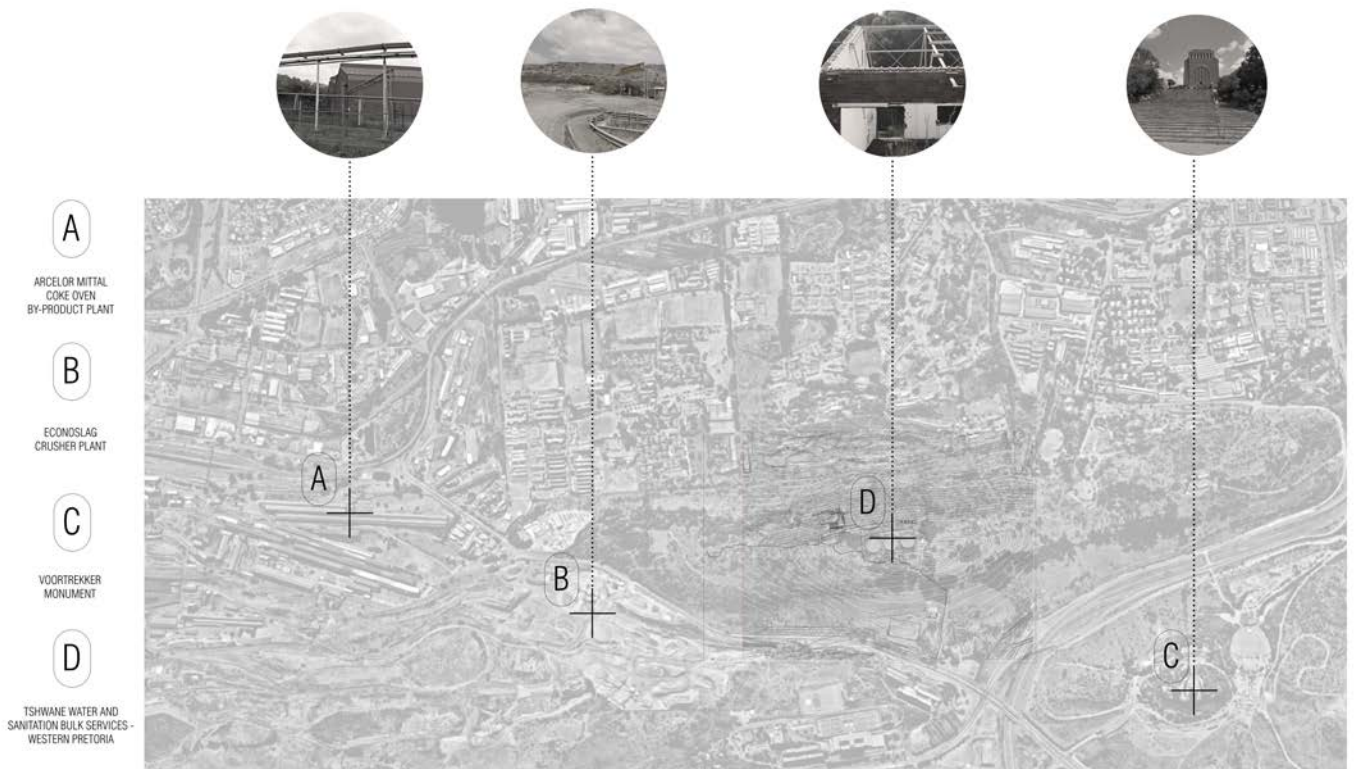


Figure 102: Allocation of surrounding sites which are used as informants for various elements of the design and structure. (2016)



Figure 103: An image of the MVA bricks site. (Google Earth 2016)



Figure 104: An image of the Econoslag crushing plant. (Google Earth 2016)

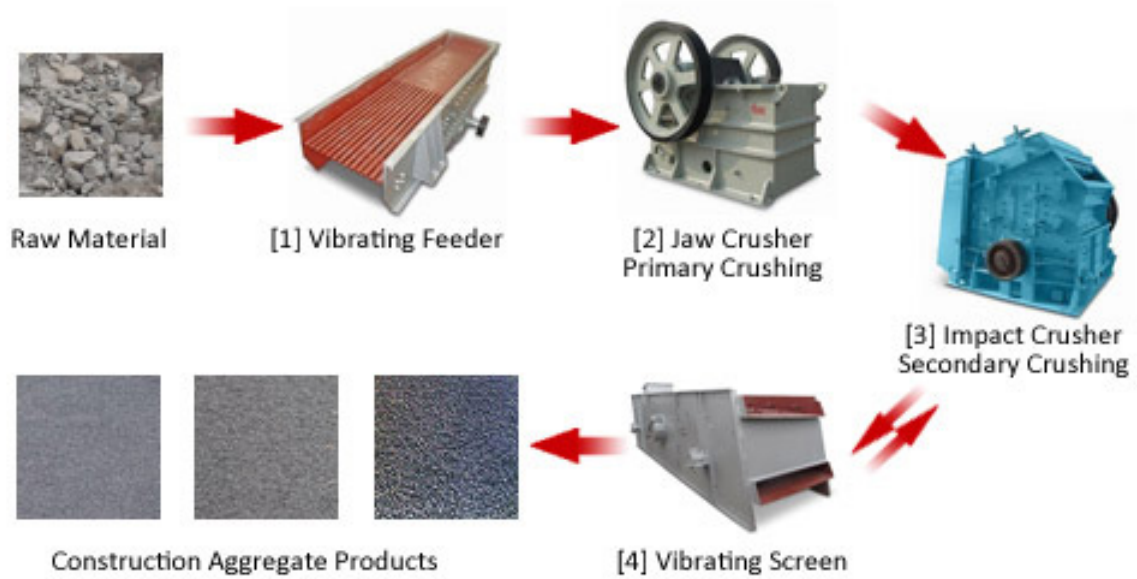


Figure 105: A flow chart diagram for the production of aggregate (DSMAC 2014)

7.3.2. CONSTRUCTION AGGREGATE

Construction aggregate, or simply “aggregate”, is a broad category of coarse particulate material used in construction, including sand, gravel, crushed stone, slag, recycled concrete and geosynthetic aggregates. Aggregates are the most mined material in the world. Aggregates are a component of composite materials such as concrete and asphalt concrete; the aggregate serves as reinforcement to add strength to the overall composite material (DSMAC 2014).

The production of aggregate as seen in Figure will be described here to illustrate how aggregates are produced using natural stones as well as recycled concrete. Even though these aggregate mines leave large footprints of unutilised land, it is part of the process of recycling earth into buildable components. The blasted raw stones are hauled to the a stockpile by a heavy duty truck; the raw stones like granite, basalt, marble, limestone, cobble stone etc. are fed into jaw crusher as primary crushing machine; the crushed stones are transferred to impact crusher for further processing; according to the clients application, the crushed stone is sieved into different grade by vibrating screen, or transferred to cone crusher for fineness crushing; after the screening process, an aggregate washing machine clears away the dust and small particles (DSMAC 2014).

In the making of the proposed structure the aggregate produced by die Econoslag crushing site is used for the production of in-situ components. Any concrete building components in some of the future scenarios may be re-crushed and reused in a different manner. This will only take place if a decision is made in a future condition to re-utilise the proposed structure in a different way.

7.3.3. MVA BRICKS

In addition to producing paving bricks, MVA Bricks also supply precast concrete kerb components. With this in mind, as already mentioned in previous chapters, the proposed structure should primarily comprise of robustness yet allow for alterations in future. Within the range that MVA Bricks supply to the public, a specific 'barrier kerb' is produced - 1000 x 250 x 100mm - which will be used in the proposed structure as a cladding element pre-disaster. The barriers may then be removed post-disaster to be replaced by lighter structural elements as part of the alterations taking place in future.

MVA Bricks also supply paving bricks to be used as a robust surface for pathways that link the different structures in the proposed design.

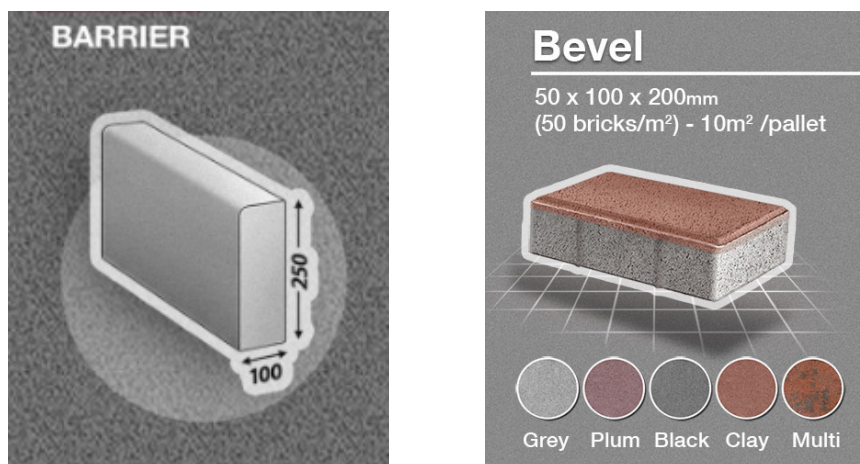


Figure 106: Barrier kerb and Bevel paver produced by MVA Bricks. (2015)

7.4 FURTHER INTERPRETATION OF SITE

Upon further analysis of the site in a theoretical manner, different conditions are illustrated (see Figure:) on section to position the site within a broader spatial framework. The aim here is to allocate where refuge will take place in relation to different margins that have formed through the development of city planning. The ridge is then analysed in terms of structural and environmental considerations as a viable site of refuge that will adhere to all architectural objectives already mentioned.

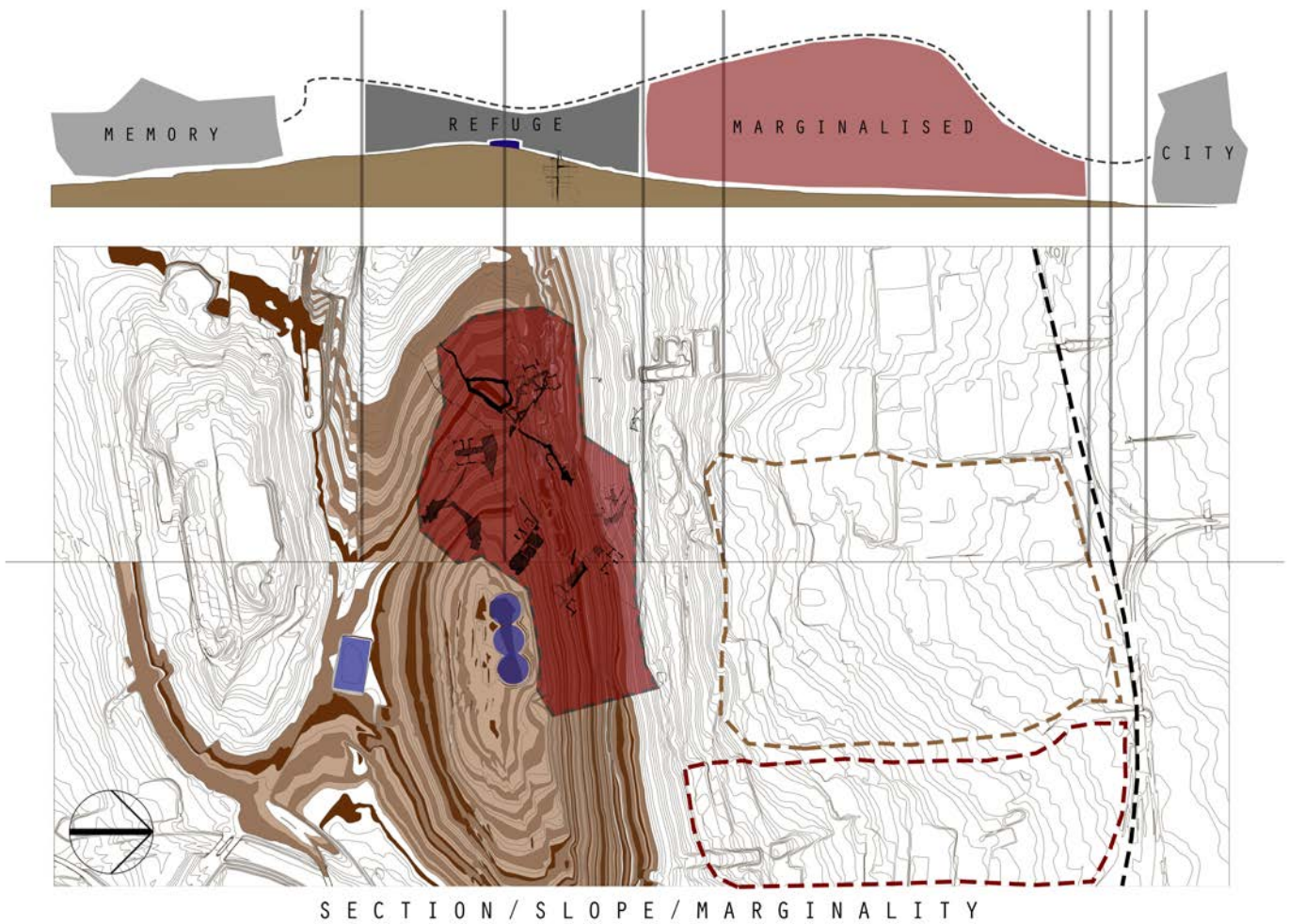


Figure 107: An illustration of the ridge slope in relation to surrounding margins. (2016)

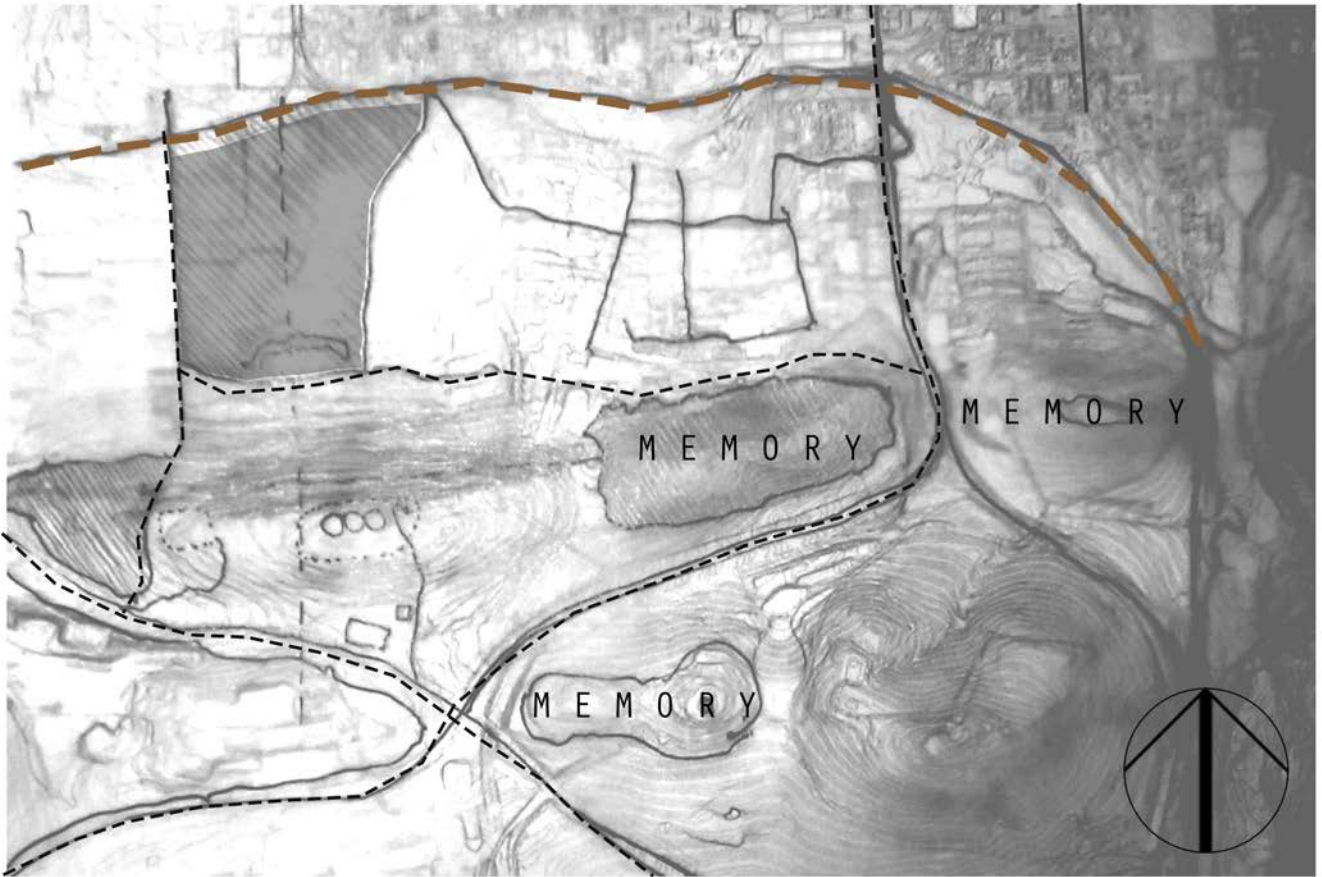


Figure 108: An illustration of the ridge slope in relation to surrounding margins. (2016)

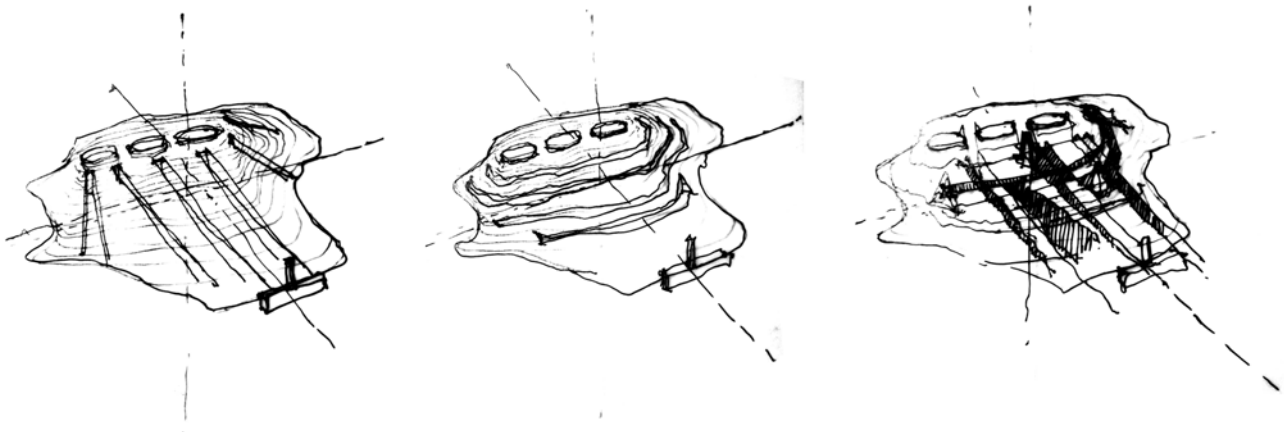


Figure 109: An illustration of the ridge slope in relation to surrounding margins. (2016)

7.4.1. INTERPRETATION OF SITE: ACTIVITIES

In Chapter 5 of the dissertation various programmes were suggested to suit the needs of the characters individually. In the overall scheme however the main activities are allocated in terms of resources found on the site (see Figure). The proposed structure acts as a mediator between the collection and distribution of resources. The design development is therefore initiated through the means of these activities and this mediation is what informs the development of the overall site plan in relation to the surrounding landscape.

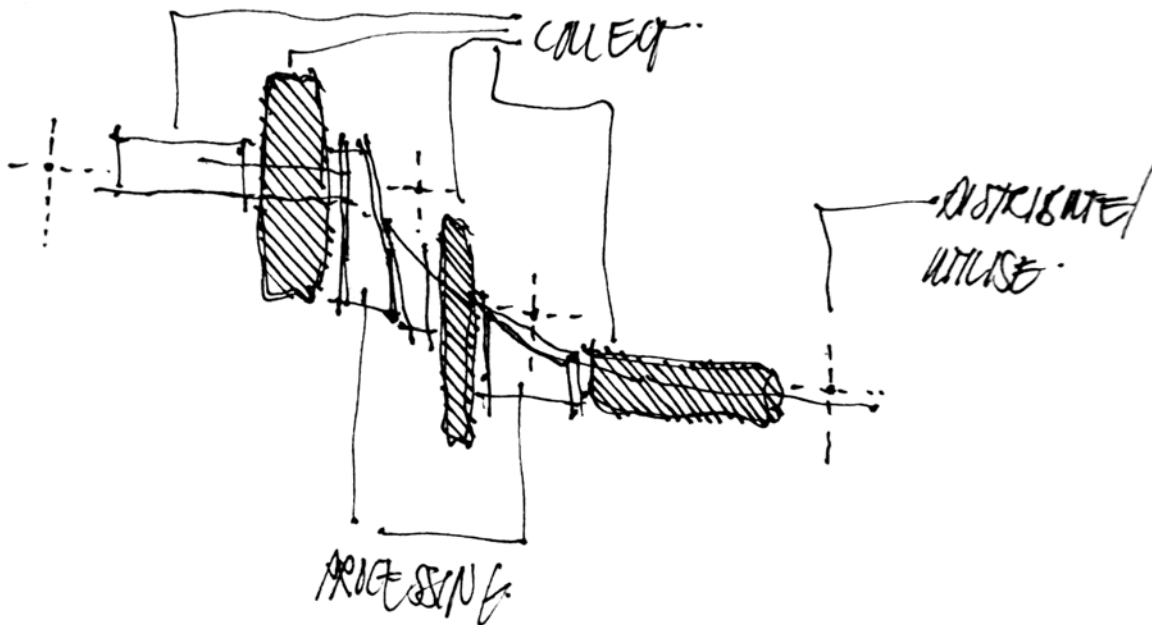


Figure 110: The mediation between landscape and building in section. (2016)

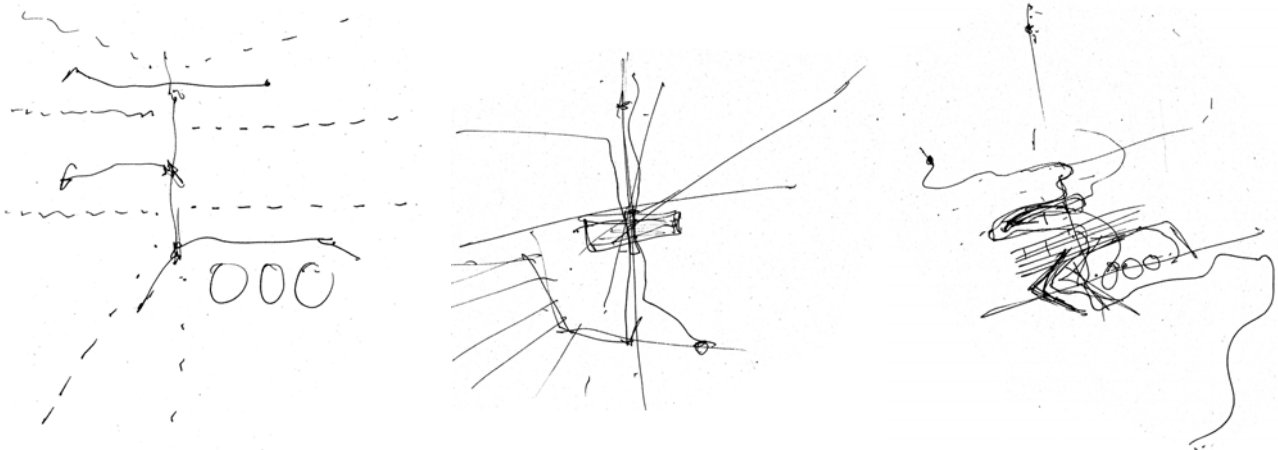


Figure 111: The mediation between landscape and building on plan. (2016)





Figure 112: Found natural objects on the site of the ridge. (2016)



The departure of 'seeking refuge' was initiated through the means of an abstract approach. In order to represent space through an alternative perception, one has to start with an alternative lens to 'seeing site/sight'. It was necessary during the initial design investigation to create abstract ideas on how to deal with different identities, functions and resources in the form of relationships. Although these do not relate directly to the development of the structure it is important to recognise the extent of the investigation.



Figure 113: Perspective drawing of the amalgamation of underground and above ground. (2016)

A B S T R A C T

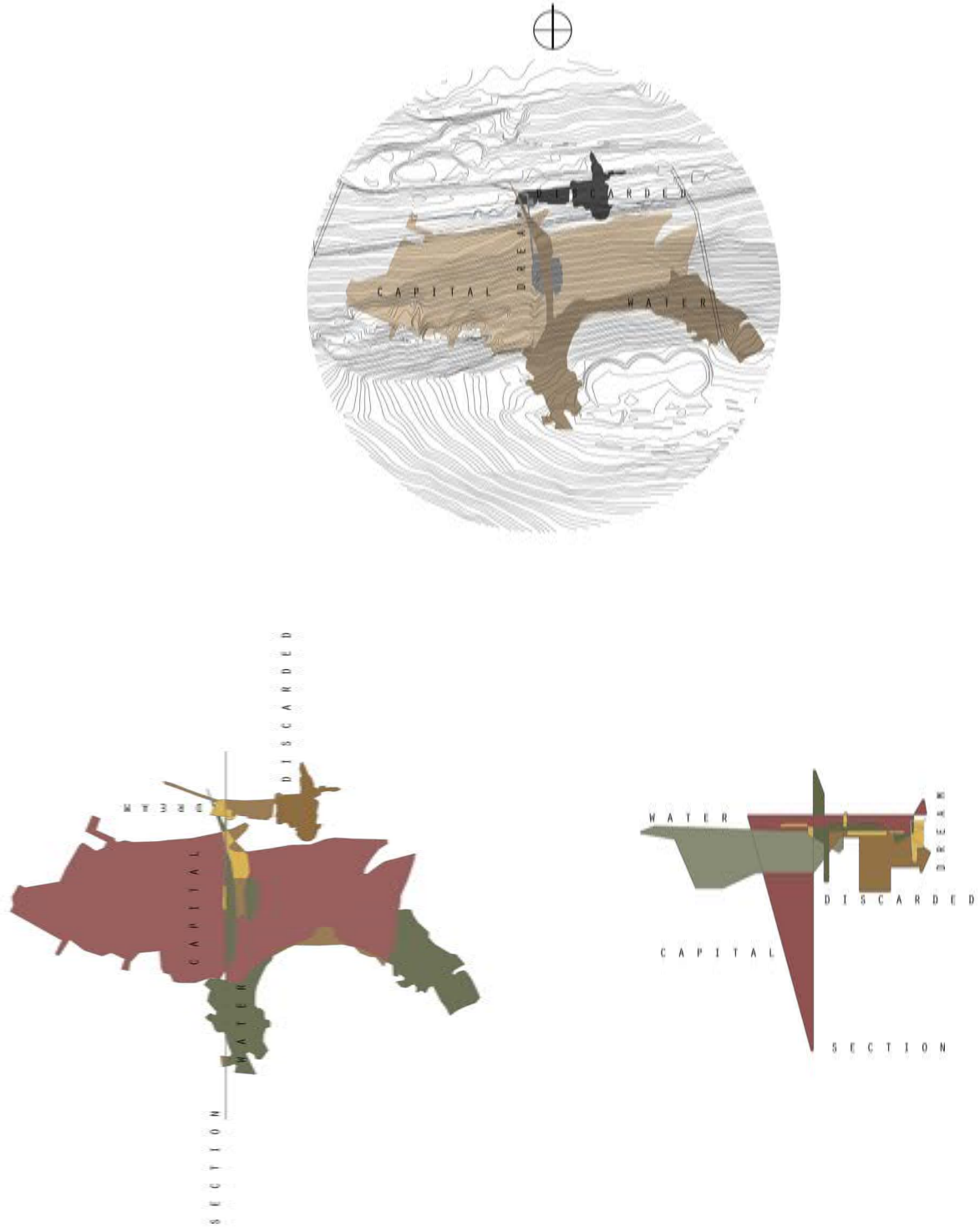
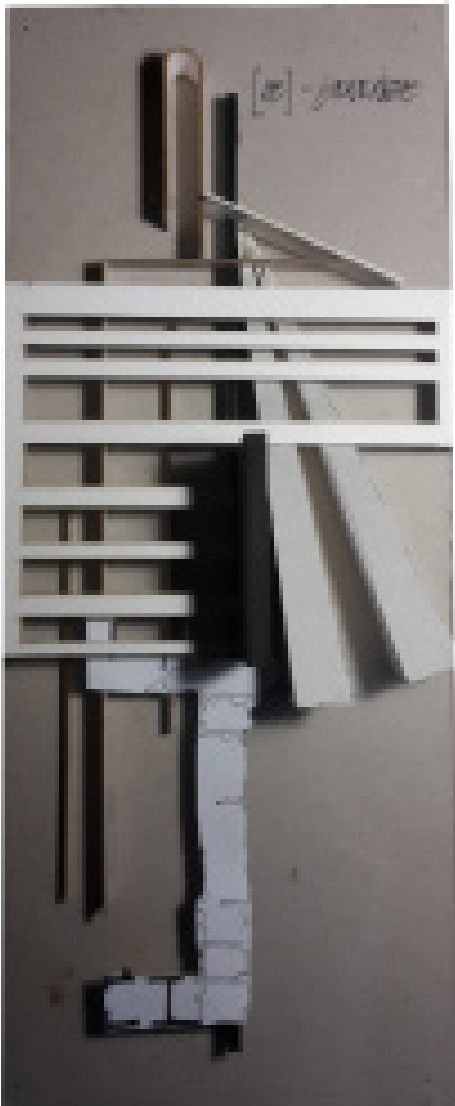


Figure 114: A series of abstracted zone diagrams with water, capital, dream and discarded and subjects. (2016)

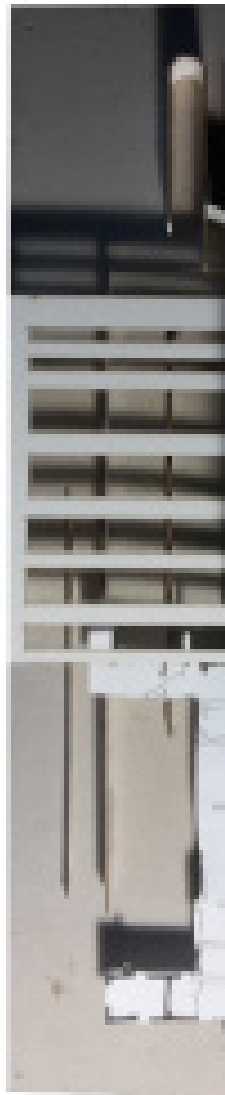
Figure 115: An initial sectional model with different representations illustrated in each image from left to right. (2016)



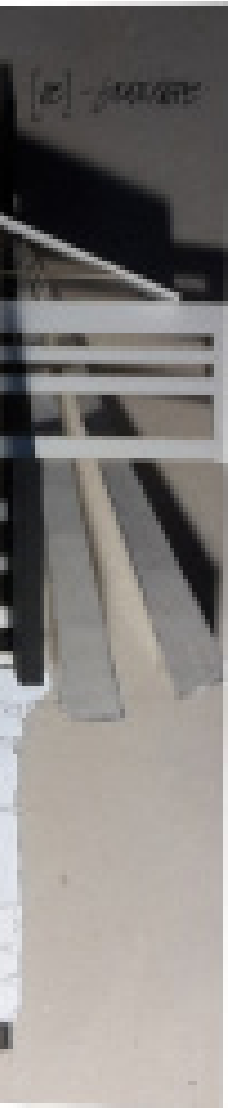
LATENT POTENTIAL



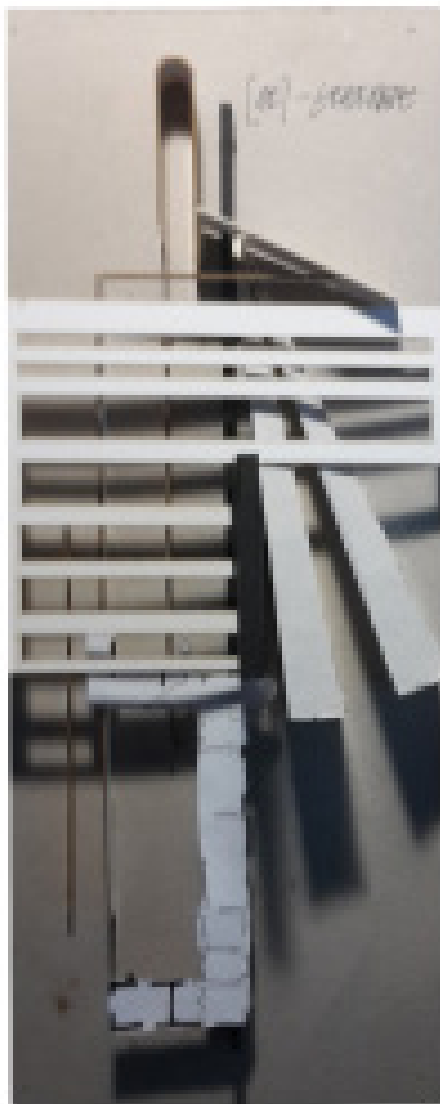
TRANSCEND BEYOND



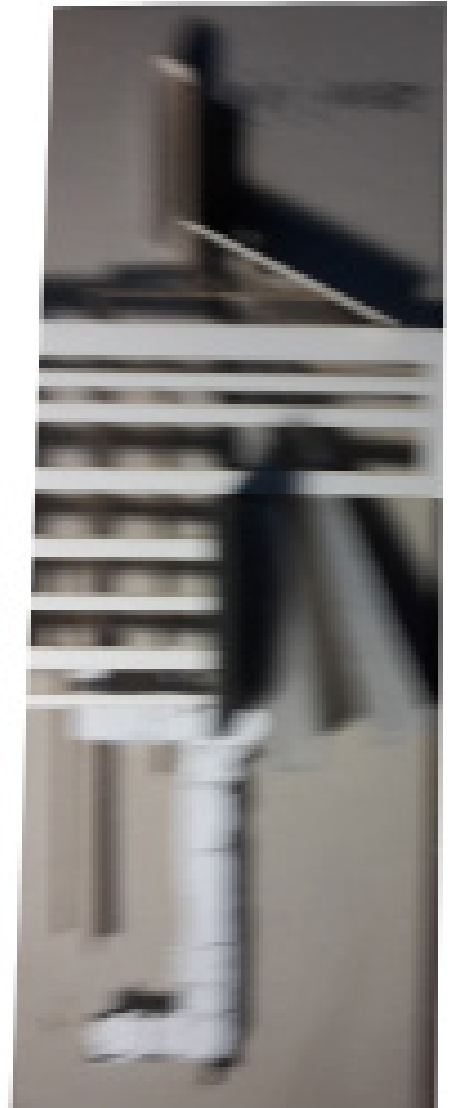
DARK



SKIES



DARK UNDERGROUND



BLURRING THE VISIBLE

7.5. CONCEPT DEVELOPMENT

The image below aims to recap on what has already been mentioned in the dissertation. We are now dealing with the 'seeking refuge' phase of the document.

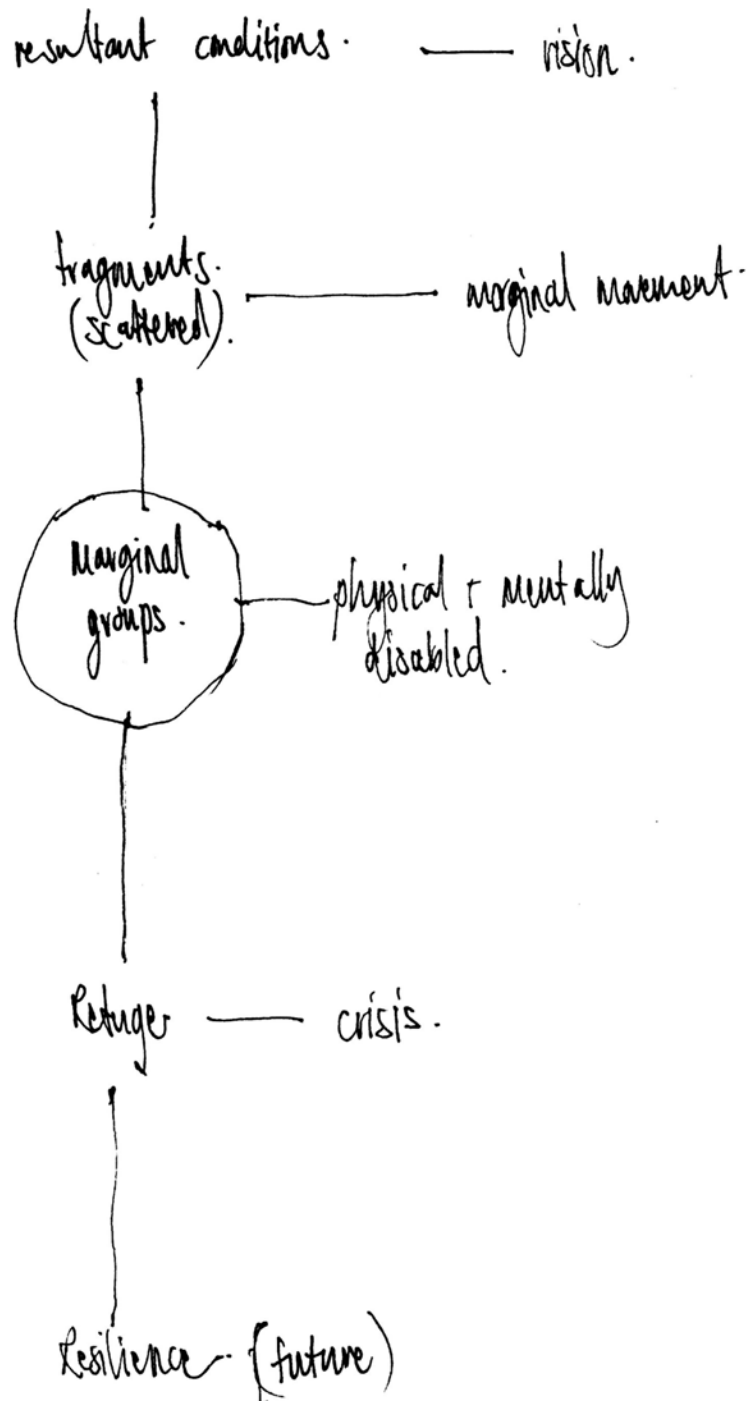


Figure 116: An illustration of the phases of development to ground the design concepts in theory. (2016)

7.5.1. CONCEPT GENERATORS IN RELATION TO SITE



The concept of shelter aims to describe the protection of a group of people during a disaster. As has already been mentioned one of the architectural objectives is to create a robust structure that can withstand disaster. Shelter in another sense also means to hide away. This idea is pulled through into the design development by creating submerged spaces with some elevated elements.

The act of merging margins can already be acknowledged in the description of possible future scenarios where the marginal community can suggest new power relations in the rebuilding of the city. Another way of merging margins is through the act of mediation. The structure aims to mediate the landscape, the resources and the people inhabiting the spaces.

The concept of 'datum' can also be described as movement along a continuous line. This idea is represented in the movement of the plan from one function to the other as well as the movement of people throughout the proposed building. This will be illustrated later in the development of the sketch plans.

The concept of being hidden or isolated is already represented in the choice of site. As has been mentioned, the Langeberge Ridge functions as an isolated natural island between various zoned areas. This idea of isolation is also pulled through from the theoretical premise that the marginal community would be able to function on its own post-disaster.

The idea of resilience or sustenance can take many forms. In the context of this dissertation the meaning of these two words is represented in the environmental considerations of the scheme. Various resources are utilised to create energy and passive systems are implemented to reduce the use of electric energy. In the introduction of site in Part one it is indicated that the three reservoirs will be utilised as sources of water as well as energy. Other environmental systems will be discussed later in the technical chapter.

Figure 117: Design generators. (2016)

7.5.2. DESIGN DEVELOPMENT FROM CONCEPTUAL GENERATORS

From the conceptual generators the following diagrams aim to illustrate a form of analysis of the slope (in section) in a way that the intentions are appropriate and relate to the initial architectural objectives of the dissertation. This also informs the rest of the design approach and development in various ways. As mentioned before, the act of excavating on a quartzite ridge could be quite costly. The aim here is to use the Econoslag crushing plant to produce concrete aggregate from the blasted quartzite in the cast in-situ components of the structure. Softer clay and sandstone excavations are used to fill the rooftops that function as green roofs.

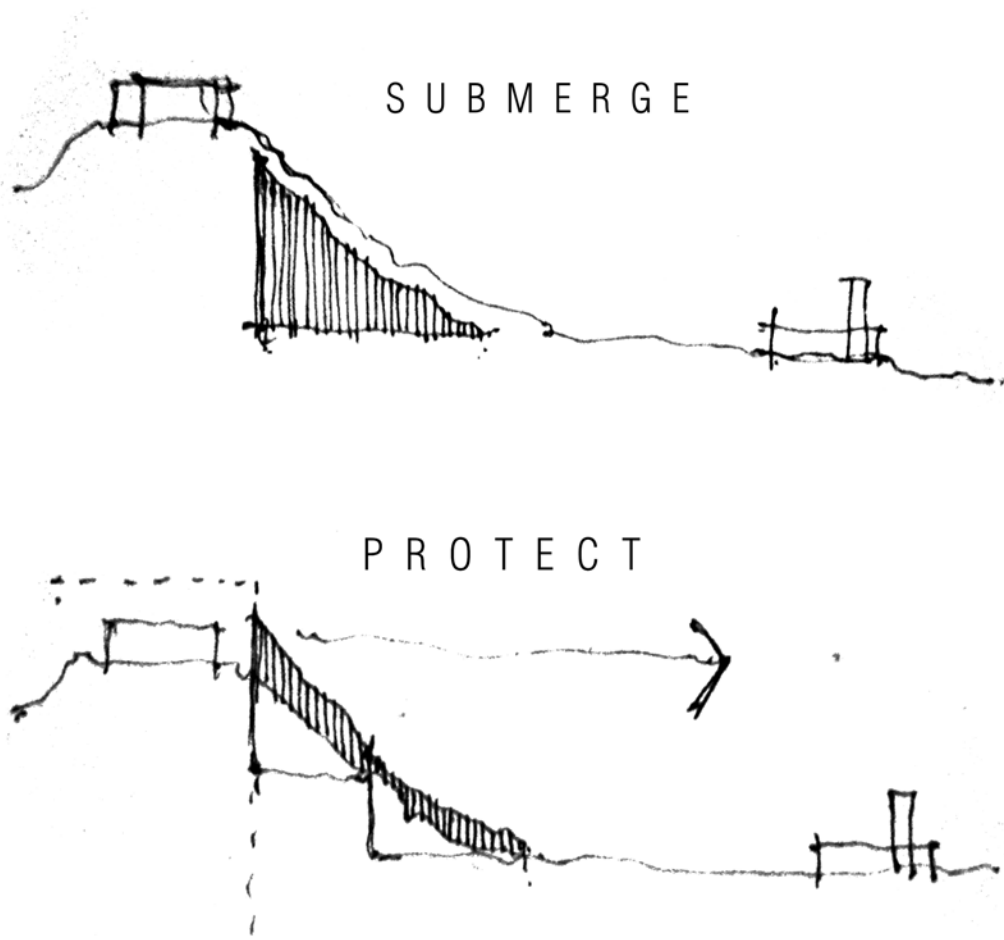


Figure 118: An illustration of the acts of submerging and elevation in a relationship to protect the marginal community from outsiders. (2016)

The diagrams below illustrate the intention of the main structural intervention on the northern side of the ridge for observation purposes and to use daylight and other natural elements to the maximum. In the design development the building intends to create its own topography yet respect the original topography.

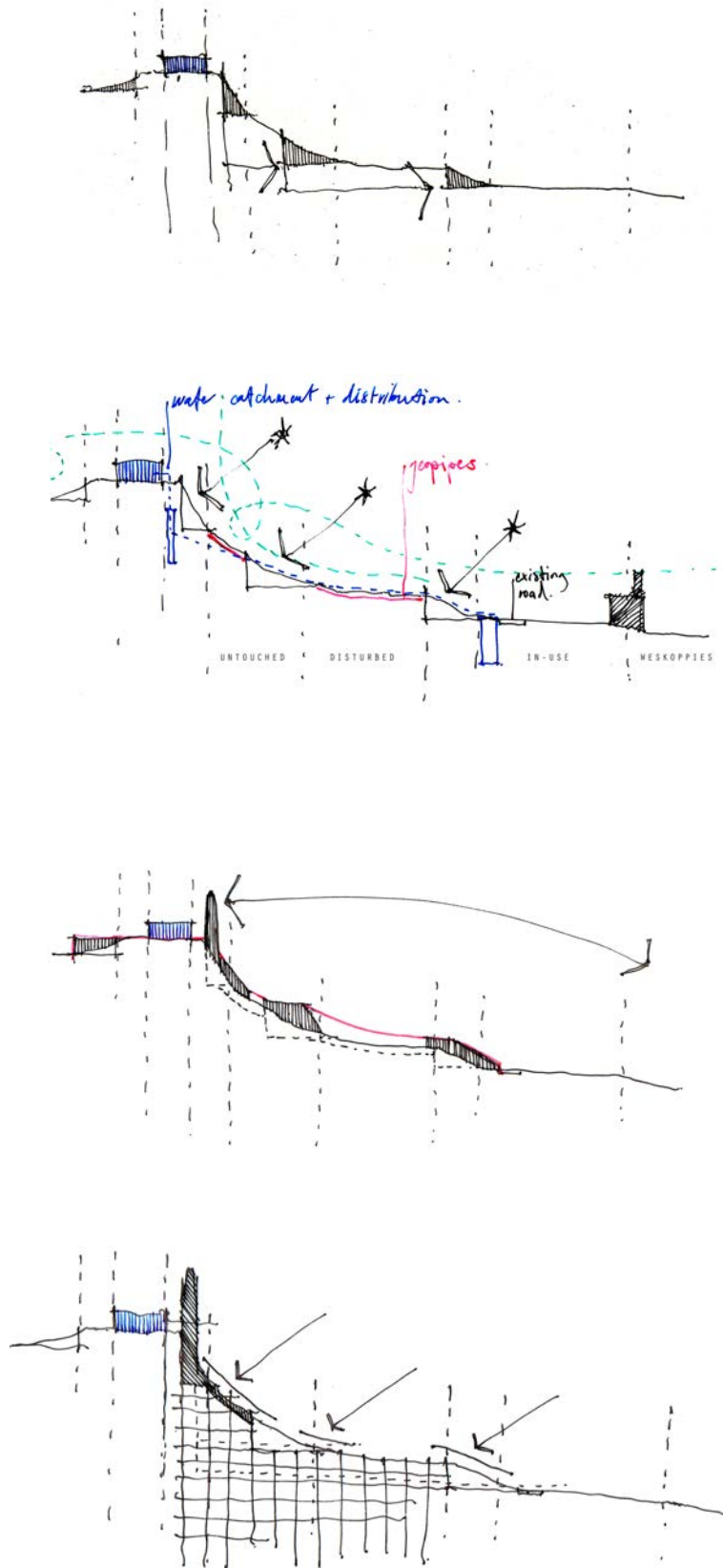


Figure 119: An analysis of the northern part of the ridge in section. (2016)

I have alluded to the negative conditions of our time, to superannuated notions of inevitable progress that are as destructive as they are fallacious. In this regard I would like to suggest that critically resistant “regions,” like “schools,” have to be created. They are, in this sense, necessary myths, as any self-consciously created culture must be. Far from being merely an illusion, a myth can become a critical and creative force. (Frampton 1987: 380)

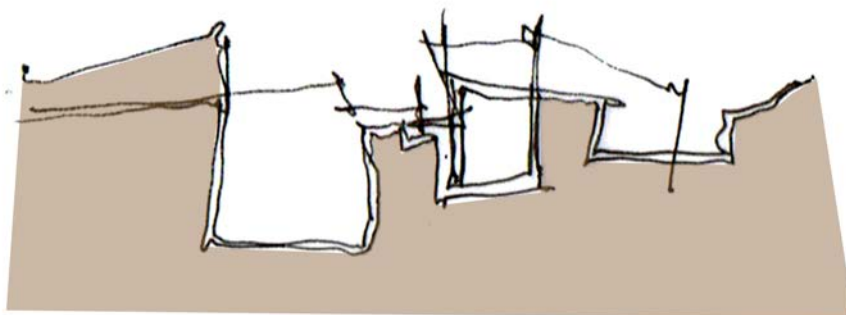
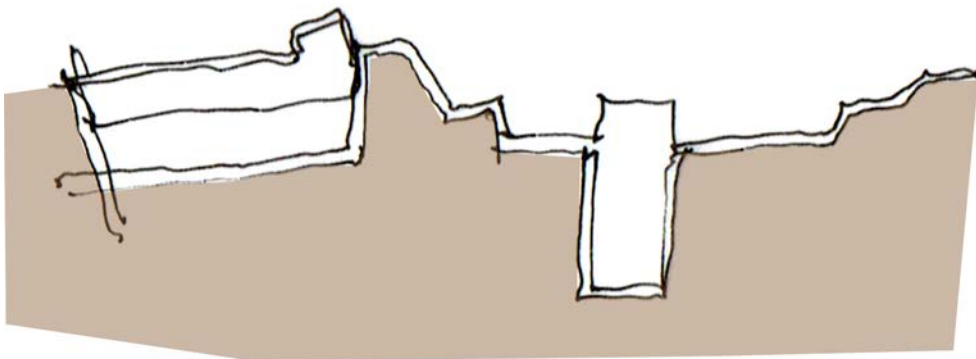


Figure 120: Indentation in the landscape to seek refuge. (2016)

7.5.3. SPATIAL EXPLORATION

The creation of form is both ambiguous and dynamic in nature. The making of place is representational as mentioned in the theoretical discourse. The following spatial explorations aim to represent a mediation between earth and structure; underground and above ground; slope and sky; and protection and observation.

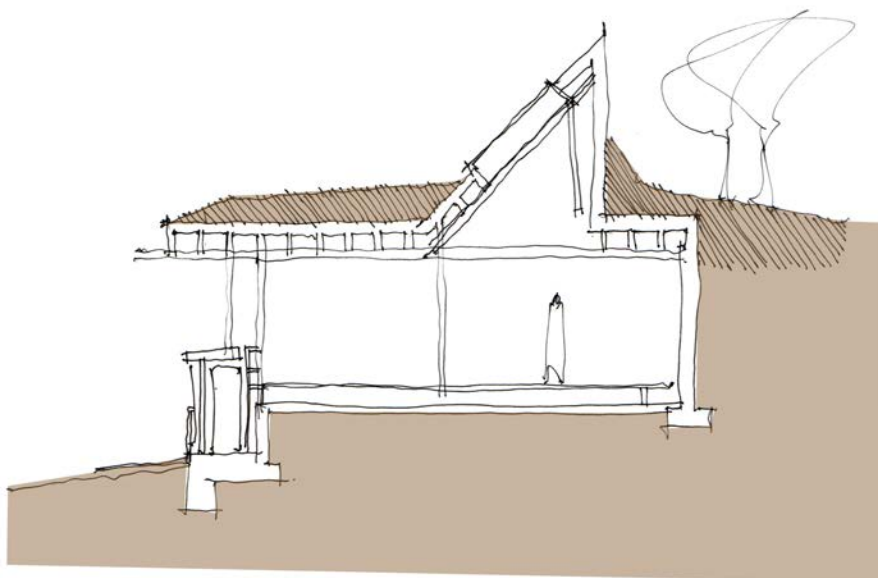
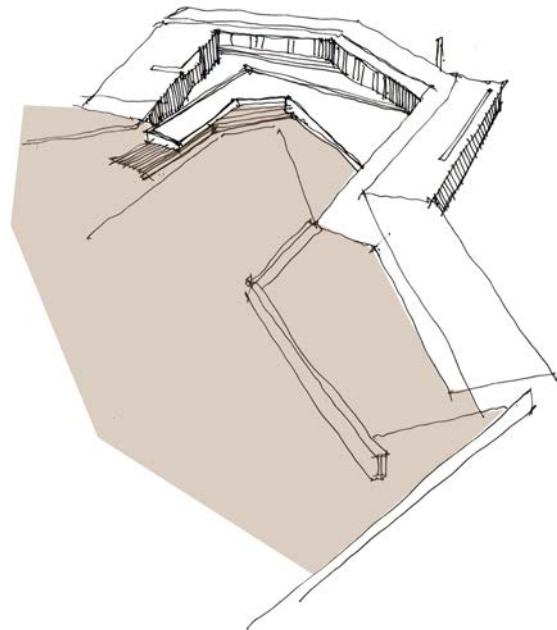


Figure 121: Indentation in the landscape to seek refuge. (2016)

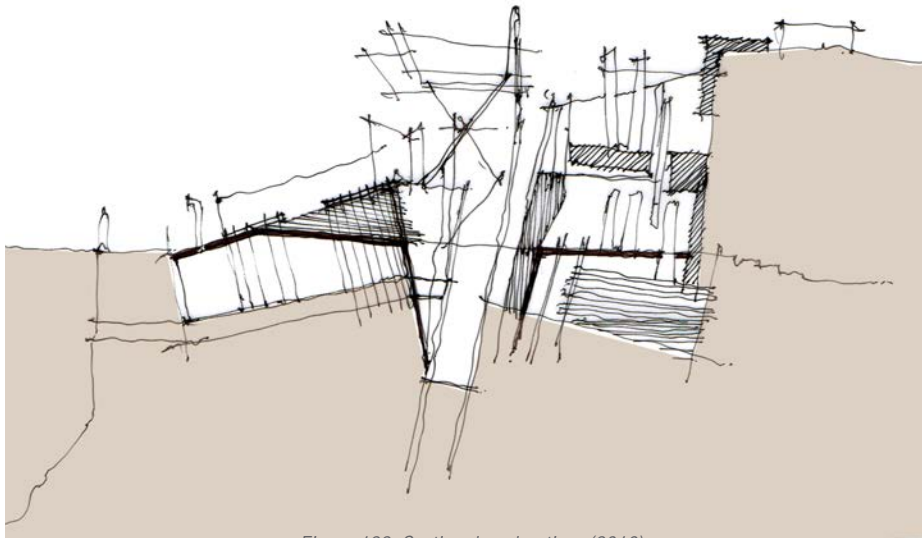


Figure 122: Sectional exploration. (2016)

Thresholds (vertical and horizontal) are intertwined in a diverse underground energy. These sections illustrate how the structure forms an identity within the slope of the site. With the water sources at the top of the ridge and during rainy seasons, a natural flow of water can occur - in some cases water is caught, filtered and stored in the proposed intervention, in other cases the structure allow the flow of water over the roofs of the structure and into constructed wetlands or designated agricultural areas.

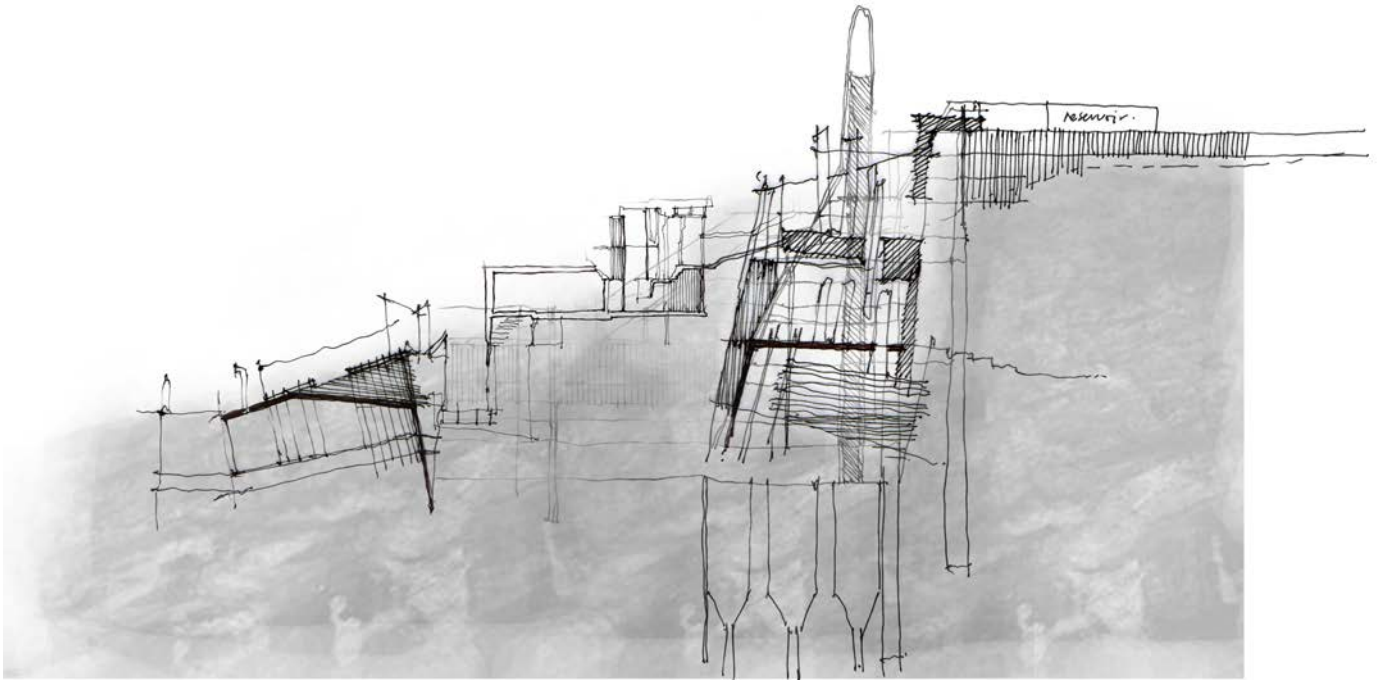


Figure 123: Sectional exploration. (2016)

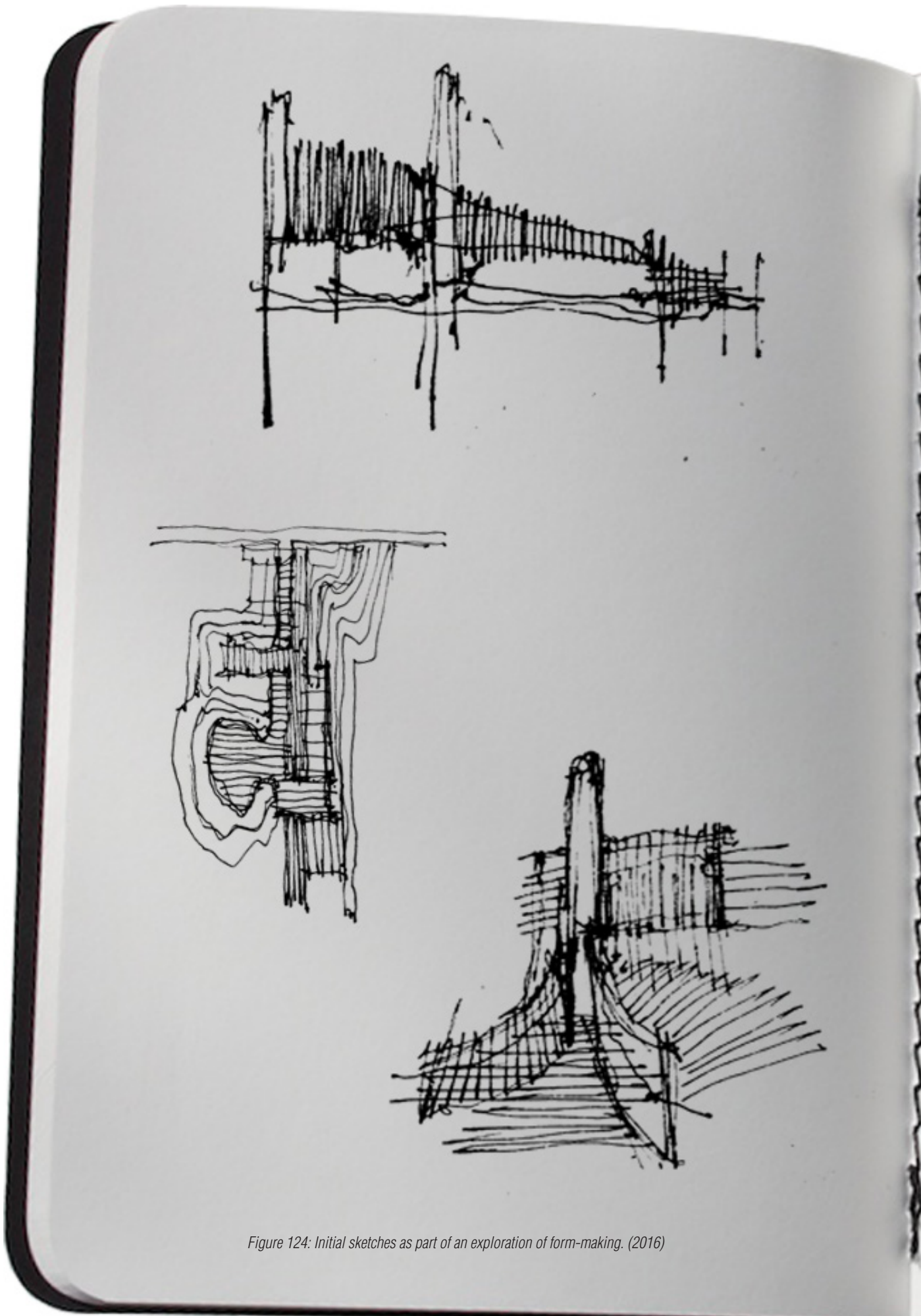
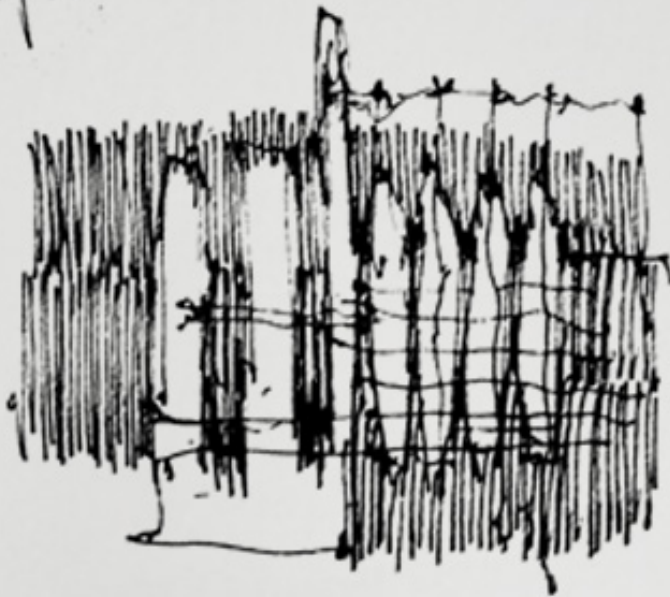
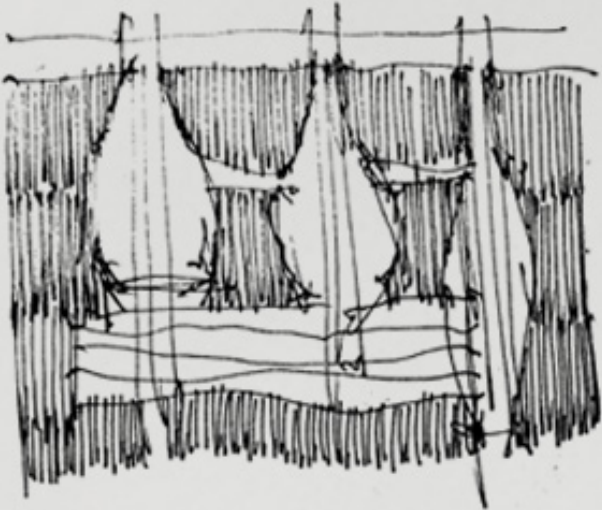


Figure 124: Initial sketches as part of an exploration of form-making. (2016)



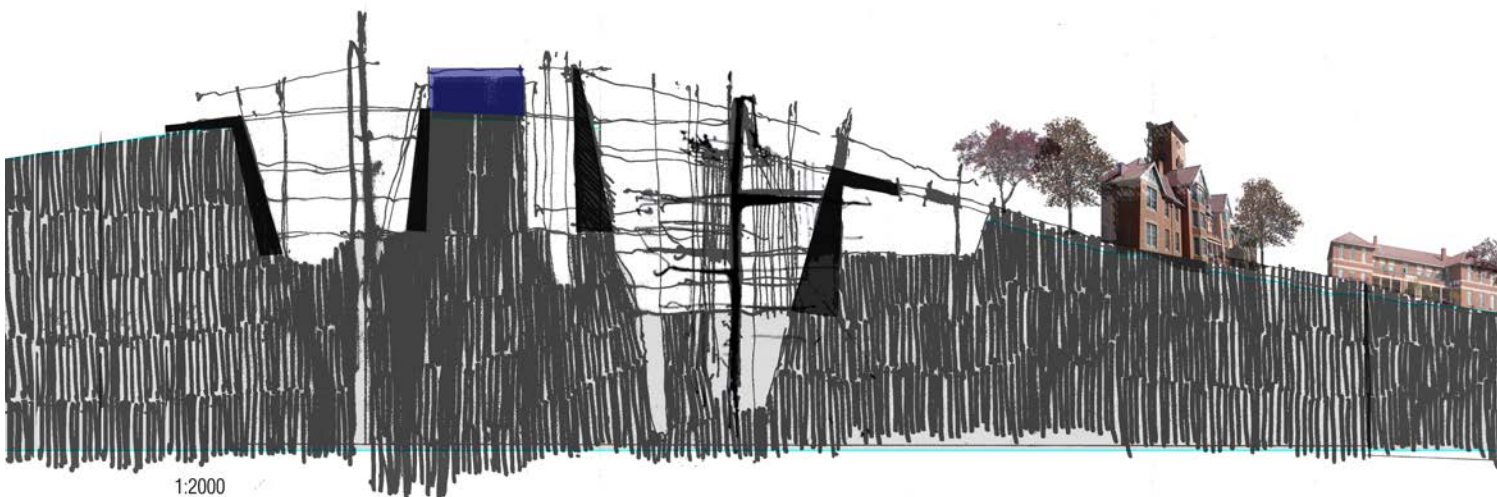
NEGOTIATING THE MARGINS

7.6. DESIGN DEVELOPMENT

Pretoria's ridges were initially intended to act as buffer protection from the invasion of enemies, the reason for the planning of 8 forts around the city centre. Only 4 forts were realised, of which 2 are in excellent condition today. What if a pilot project could be introduced to complete the initial intentions of the fortification of the city?

Based on the existing marginalised condition, it is necessary that the architectural intervention inherit self-sustaining strategies in order to function independently after the act of disaster. The aim, structurally, is therefore to create a robust shell, with the ability to provide and preserve specific resources over time (seeds, plant and animal artefacts, water, agriculture and archival material).

As part of the narrative of the dissertation, the new architectural intervention has a few objectives. Firstly, to function as a fort-like structure in order to protect those in most need; secondly to become a starting point for communities to re-establish an identity by developing skills; and thirdly to become a self-sustaining sanctuary over time.



Materials are largely based on excavated earth and stones reclaimed on site. For the robust shell, cast in-situ concrete is used, with some steel work for large spans and heights. All surfaces directly linked to the slope of the site, should emphasise the concept of camouflage and retain the agricultural value of the site - green roofs will be implemented here to assist with erosion and groundwater filtration. Furthermore, a collaborative concept exists throughout the structure. Some elements having to withstand destruction and others being able to adapt to the natural ecology of the site. The existing reservoirs at the height of the slope are utilised for rainwater harvesting, alternative energy strategies as well as creating synthetic environments for food sources such as fish and water-plant life, in order to sustain the community in future.

As part of the concept of refuge, the architectural intervention aims to facilitate the need for shelter and protection while developing the skills and potential of the marginal community. As mentioned before, the ecological heritage of the site pertains to the historical location of the original botanical gardens of Pretoria. As a result, the value of ecology is of great importance. Therefore, the aim of the structural intervention is to impact minimally on the surface while value is added to the environmental potential of the site. The building is subterranean with some elevated elements - this is based on the concept of surveillance, observation and perception throughout the site. Daylighting, waterproofing, temperature fluctuation and soil erosion is therefore critical during technification.



7.6.1. THE CONCEPT OF UNDERGROUND

Underground structures have been used widely in a range of conditions throughout history to meet specific needs. Some of these needs can be summarised as follows:

1. To achieve a moderate ambient indoor climate in regions with stressed climates such as dry and cold or dry and hot.
2. To meet religious ceremonial needs.
3. To meet defense needs.
4. To save agricultural land.
5. As storage space for agricultural products (especially wheat).
6. As civilian shelters against air attacks.
7. For educational purposes.

(Carmody 1985)

It can be argued that many of the above mentioned needs are practical alternatives for human shelter if the nature of the environment allows for the creation of such spaces. In the context of this dissertation the main purpose of utilising the 'underground' is for protection and simultaneously the creation of a moderate indoor climate which will be discussed in the technical chapter.



Figure 126: Types of earth shelter design. (2016)

A prime example of a civilisation who relied on their specific environment for survival and shelter is that of Cappadocia.

7.6.2. CAPPADOCIA, TURKEY: UNDERGROUND SETTLEMENTS

In Cappadocia, Turkey, two subterranean cities exist today - Derinkuyu and Kaymakli - which are still inhabited by the settlers in these areas. Some of the first settlements comprised of communal dwellings cut out of the rock of the hillsides (Carmody 1985:). After several invasions, the original settlers were forced in self-defence to develop the underground system extensively. These settlements are a significant example of how man has to adapt to his natural context in order to survive. The communities grew grapes and other fruits and vegetables and utilised underground spaces for storage of food.

One of the main responses of the creation of the subterranean spaces was the scarcity of good timber and materials for mortar but for the protection of inhabitants against invaders (Ahrens, et.al. 1981:15). The relevance of this underground community as precedent does not necessarily relate to form, instead it relates to the creation of a community which had to adapt for protection of the inhabitants.



Figure 127: A photograph of the Monks Valley in Cappadocia, Turkey. (North Cappadocia tour [sa])



Figure 128: Underground living. (Ahrens, et.al. 1981:8)

With the collaboration of the University of Minnesota and the Underground Space Center, during the 1980's a rapid popularity developed for underground or earth sheltered design. The reason for the exploration into this architectural 'style' was mainly based on the consumption of energy. With the rising cost of fossil fuels, the evolution of earth sheltered architecture introduced alternative ways of dealing with active and passive strategies. Although it is suggested that a typical house design on the surface can use active and passive solar strategies as well as insulation to achieve appropriate energy performances, earth sheltered design have additional advantages (Ahrens, et.al. 1981:9).

The advantages are listed below:

- *A moderate climate is achieved.*
- *The surrounding earth dampens noise from the outside.*
- *The masonry or concrete used for structural purposes are rot- and vermin-proof.*
- *The masonry or concrete is fire-resistant.*
- *The underground structures are less damaged by natural storms and other disastrous occurrences.*
- *An attractive landscape or view can be preserved while allowing access to natural light.*
- *The concept of working with nature as part of the design.*
- *Forms of earth sheltered designs tend to compliment and duplicate forms found in nature.*

(Ahrens, et.al. 1981:9)

Earth covered walls only



Earth covered walls and roof partially recessed



Earth covered walls and roof fully recessed



Above and below grade space combined

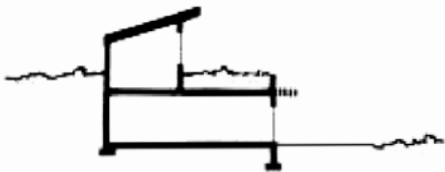


Figure 129: Various relationships to the surface. (Ahrens, et.al. 1981:12)

7.7. SPATIAL DEVELOPMENT

Based on the complex nature of the programmes introduced earlier, an ambiguous system had to be developed to tie the different functions together to form a symbiotic relationship and a flow of movement - between people, nature and resources.

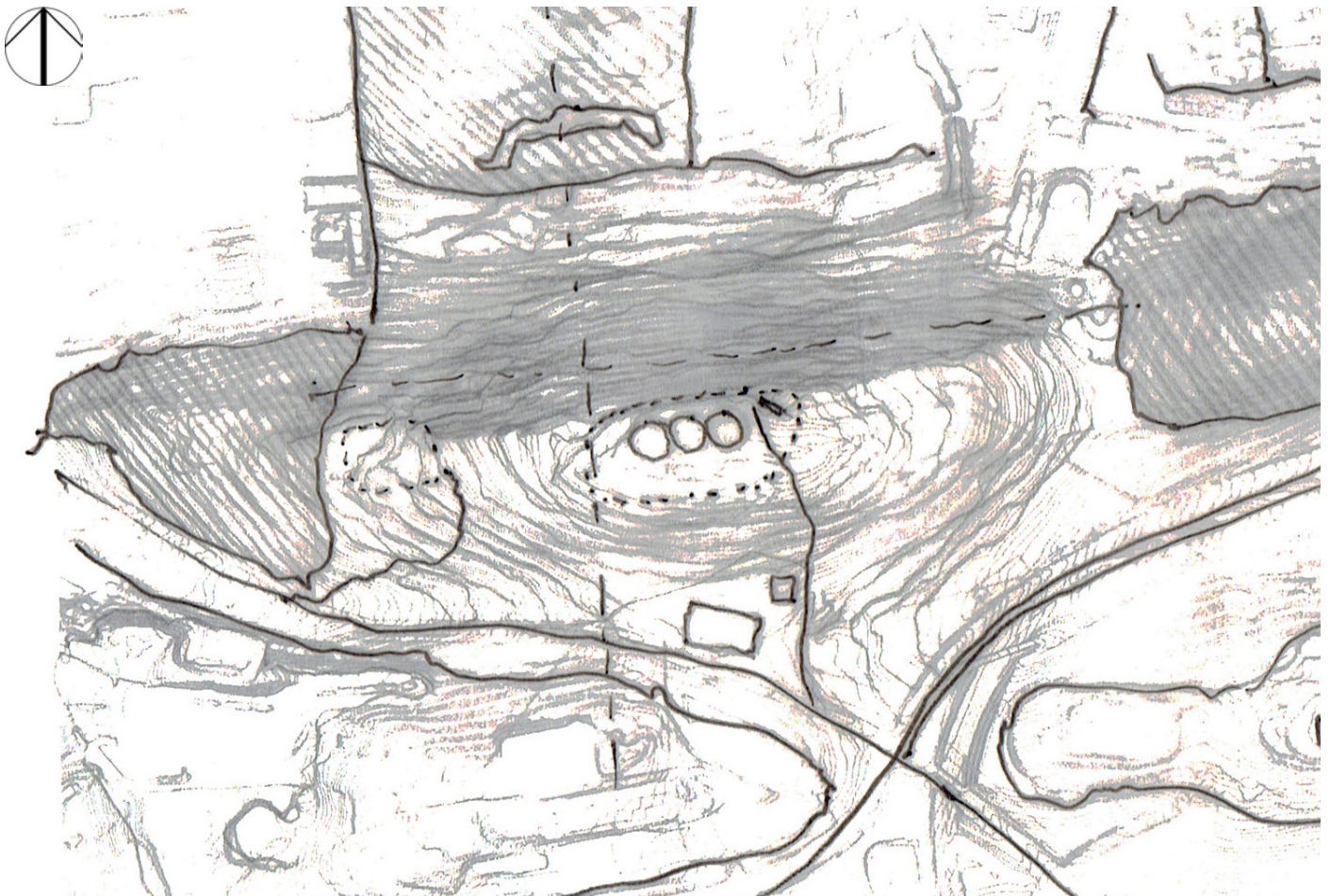


Figure 130: A drawing of the site on plan to illustrate the nature of the ridge in its context. (2016)

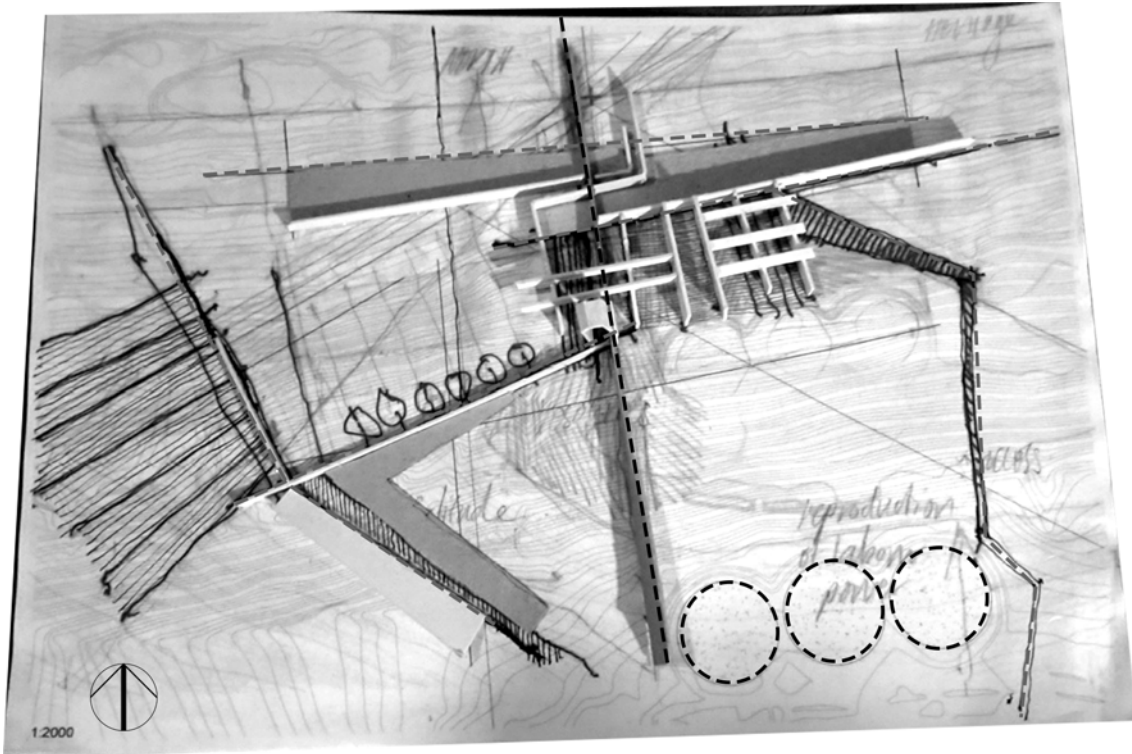


Figure 131: Site exploration by means of a model. (2016)

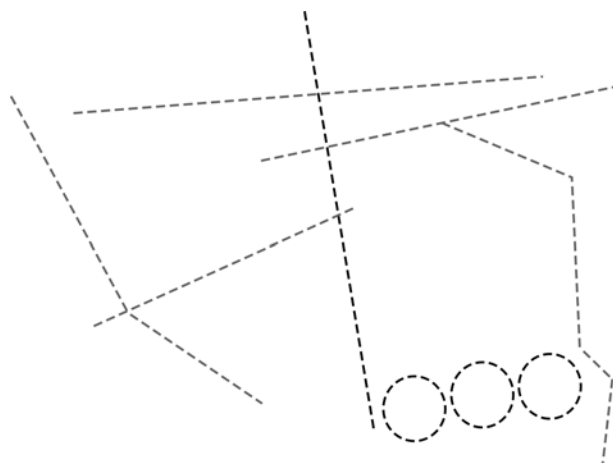


Figure 132: Delineation of lines created by model exploration. (2016)

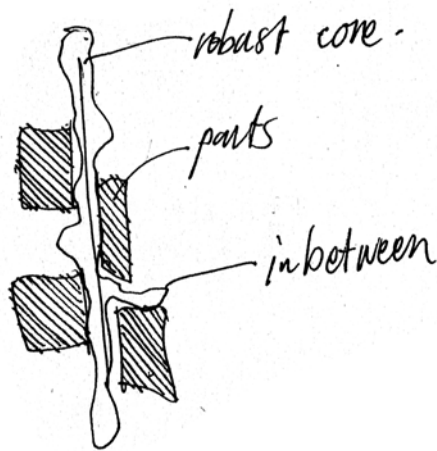


Figure 133: An diagrammatic drawing to illustrate the concept of a robust core, parts and the inbetween. (2016)

During the initial design development of the plan layout, an integrated concept was adopted so that the structure forms a robust core for the different functions/parts to latch onto and the inbetween spaces represented the flow of movement. A few explorations were conducted to recreate the concept on plan which lead to the first design iteration of representational space.

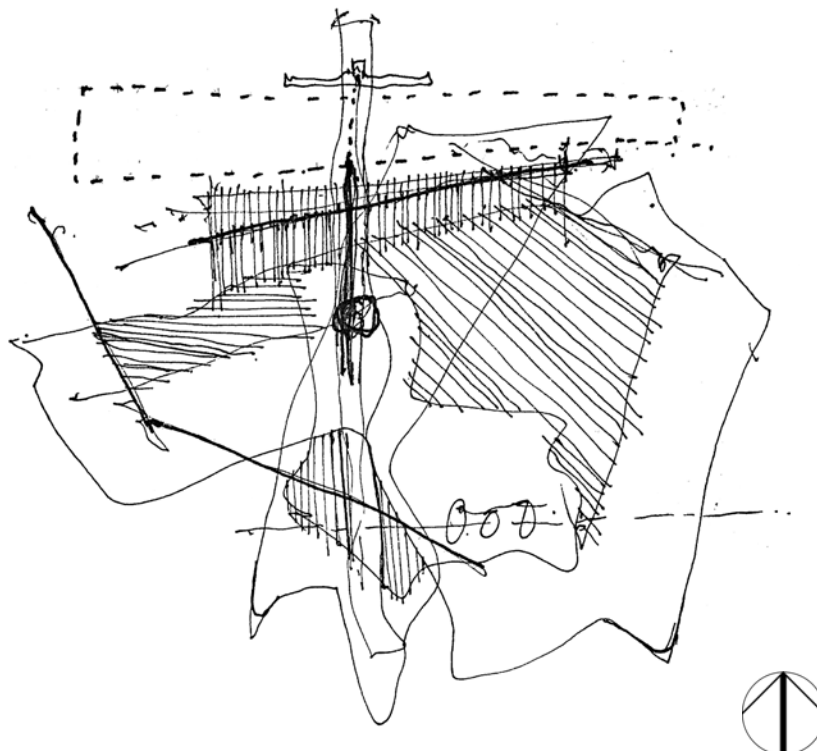


Figure 134: Site vision drawing. (2016)

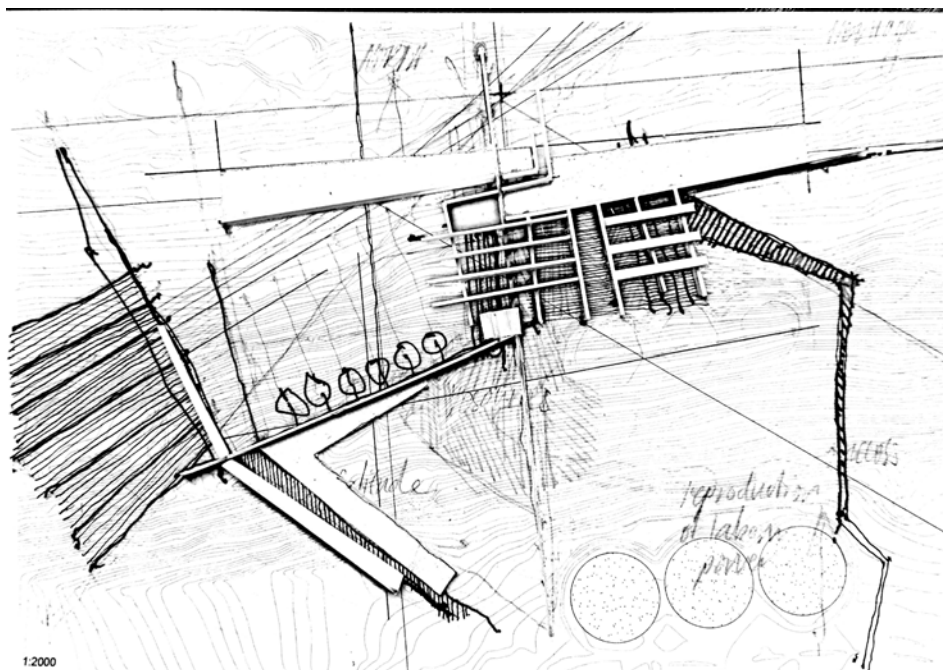
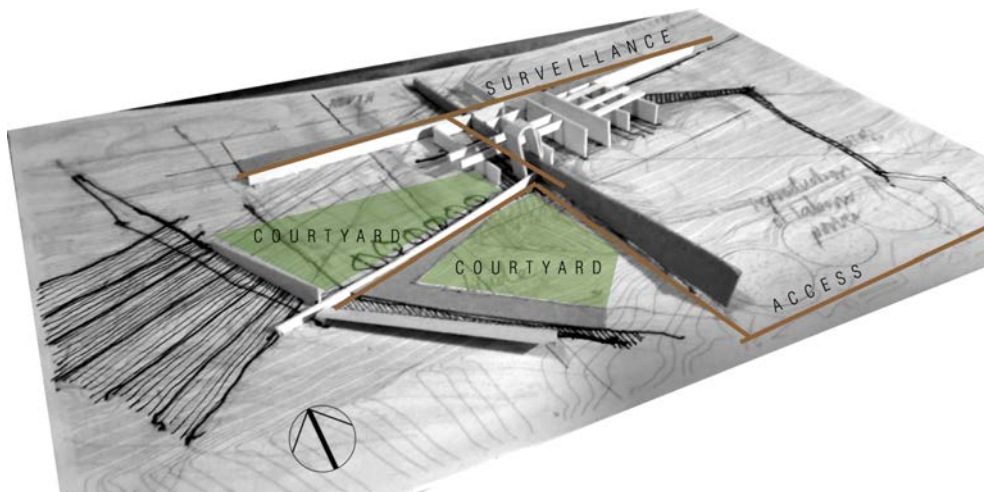
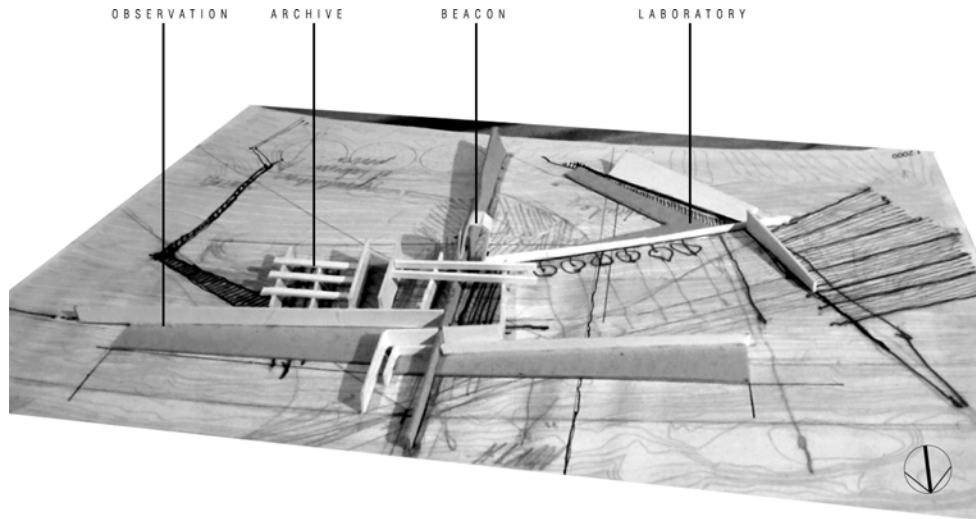


Figure 135: Model explorations of an integral system. (2016)

7.7.2. DESIGN ITERATION 2

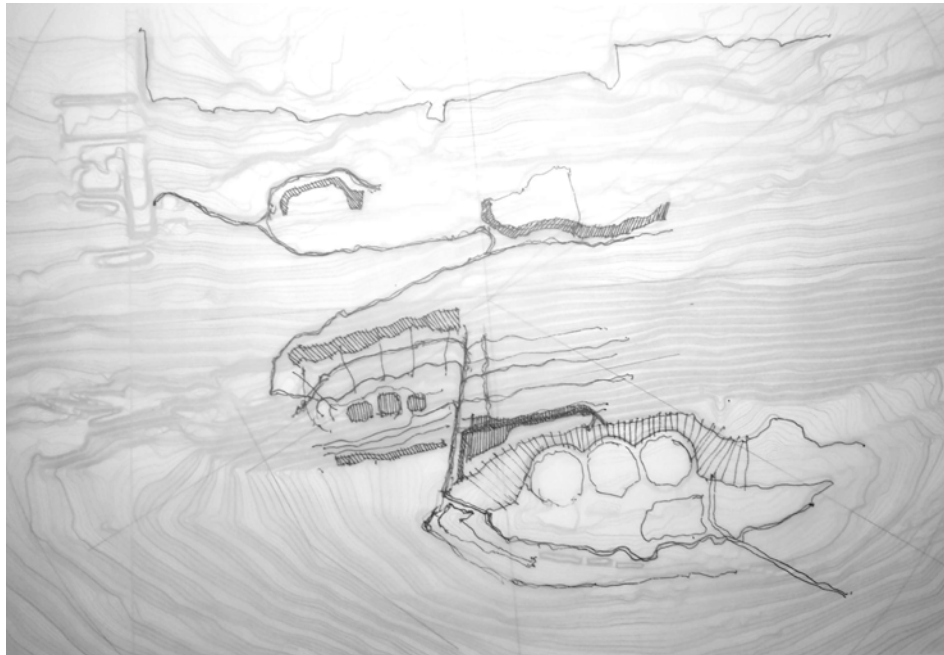


Figure 141: Development of site layout during design iteration two. (2016)

The second design iteration focused primarily on the relationship between landscape and the movement through landscape. Informed by the spatial layouts of Pretoria's forts this iteration moved closer to the existing reservoirs so as to surround and protect this resource. This decision also enabled the layout to extend to the eastern part of the reservoirs, linking to the existing pumphouse and simultaneously creating a linear extension for observation. The flow of this spatial layout reacts more sensitively to the topography of the site by using the contours as an informant of movement. The layout also considers the distance of the movement of water from the reservoirs to the proposed structure. In the preparation phase before the disaster takes place, some of the reservoir water is pumped into underground tanks as a precaution, to be used immediately after the disaster takes place.

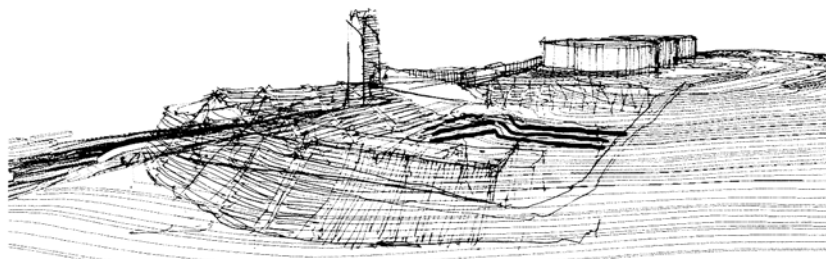


Figure 142: Three dimensional drawing of the potentials of design iteration two. (2016)

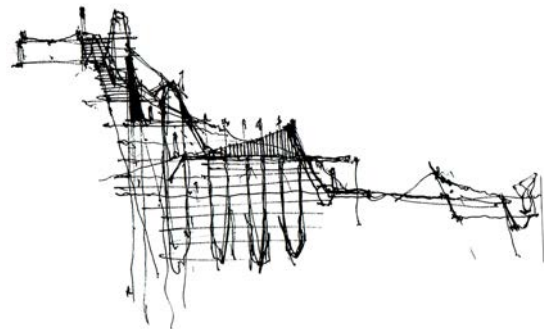
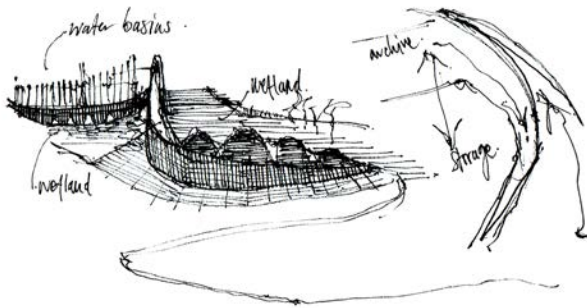
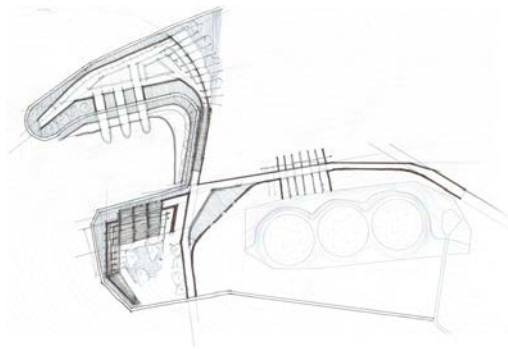
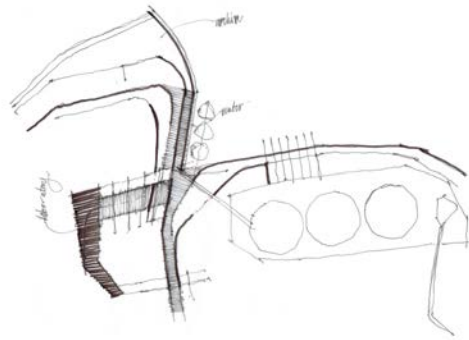
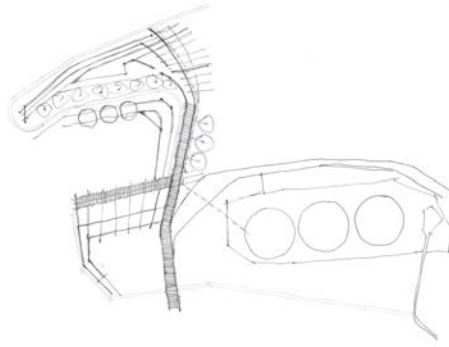


Figure 143: Exploration drawings of site layout and form of design iteration two. (2016)

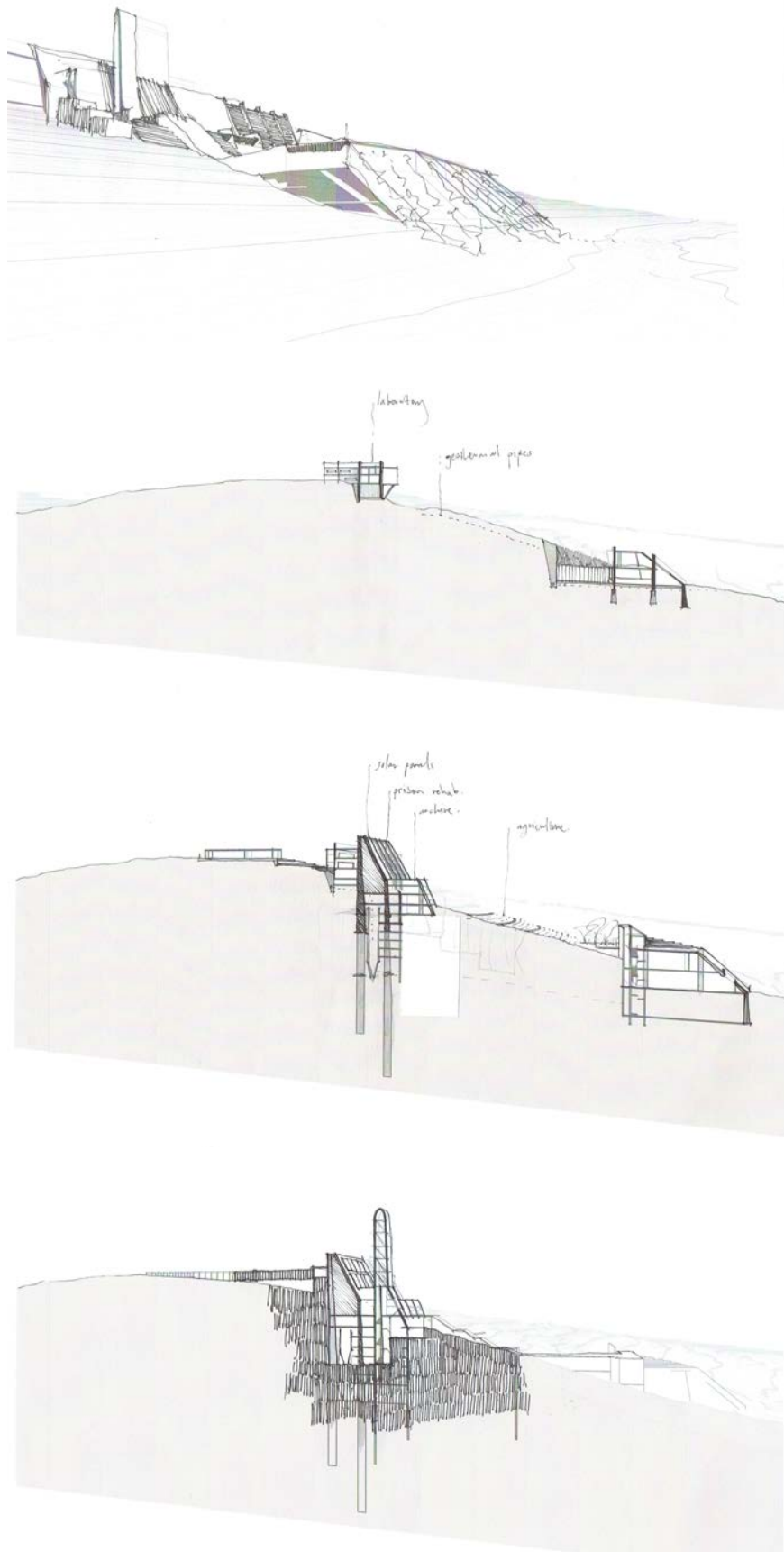


Figure 144: 3-dimensional and sectional explorations of design iteration two. (2016)

The design iteration also focused on environmental considerations. The following three-dimensional sections aim to illustrate how these factors were considered throughout the structure. Most of these considerations are pulled through into the final design development yet are resolved more sensitively in the development of sections.

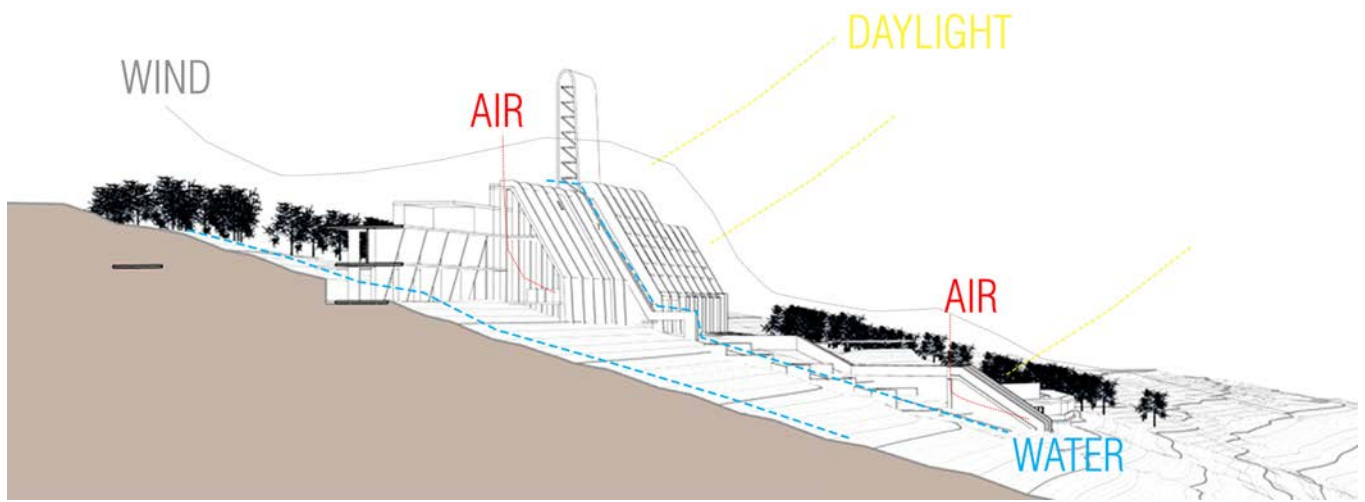


Figure 145: Sectional 3D illustrating environmental strategies. (2016)



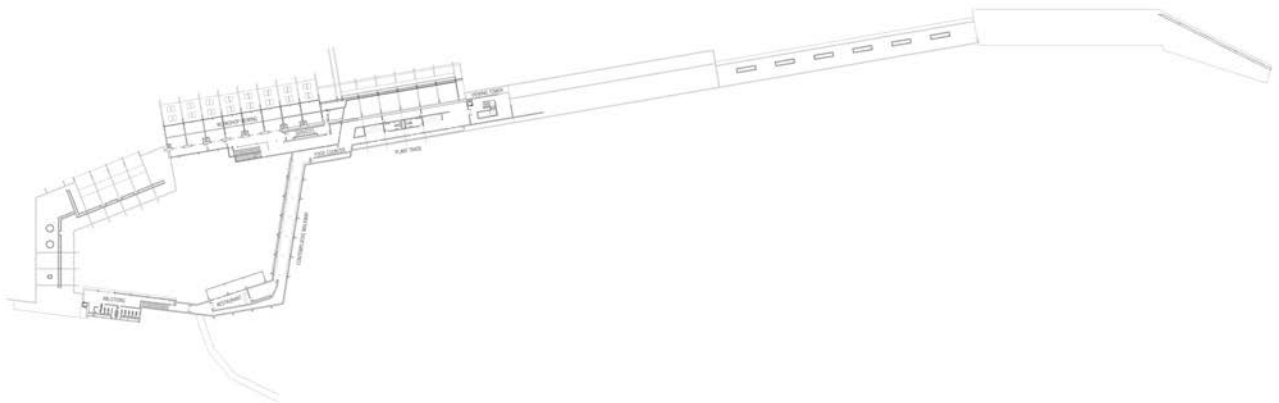
Figure 146: Sectional 3D illustrating environmental strategies. (2016)

Figure 147: Site layout of design iteration 2. (2016)

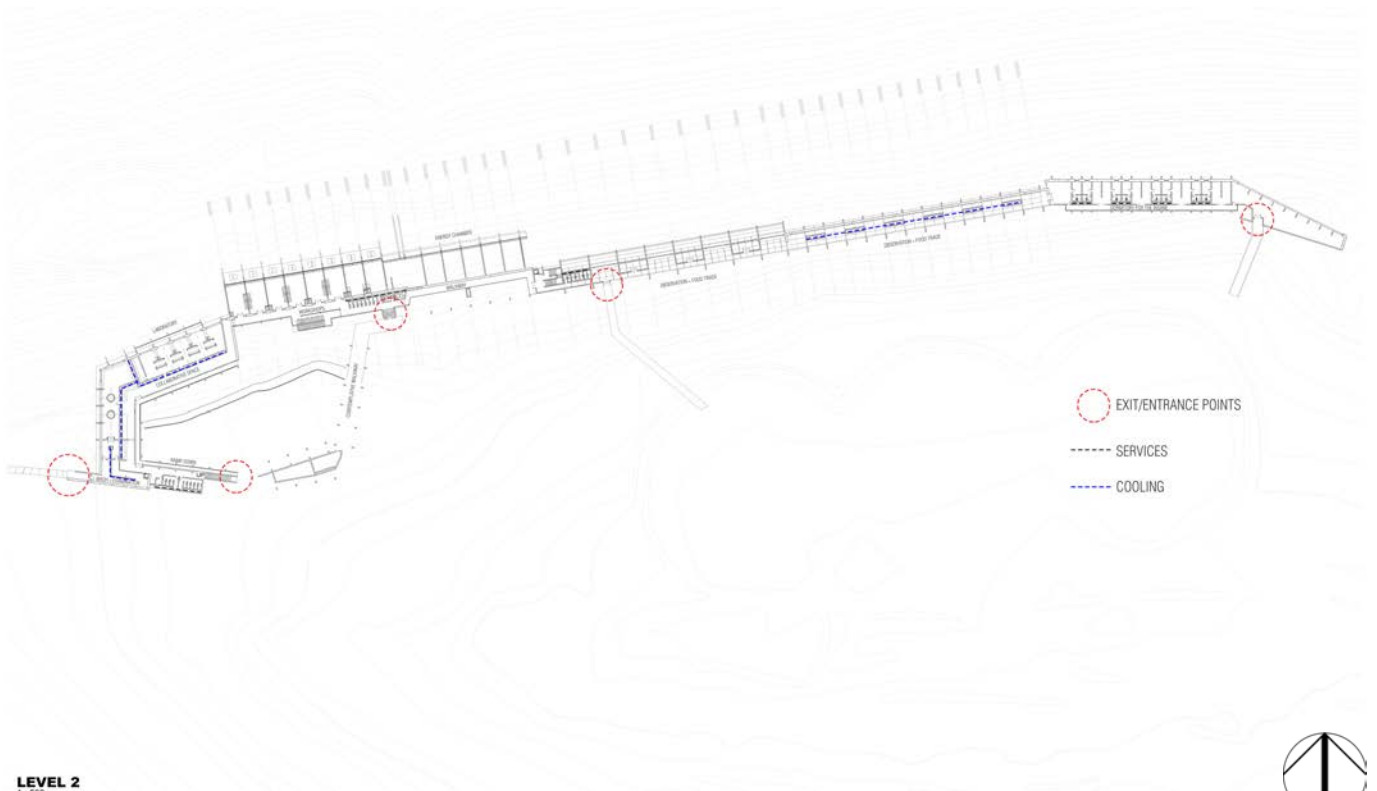




Figure 148: Plan layouts of different levels of design iteration 2. (2016)

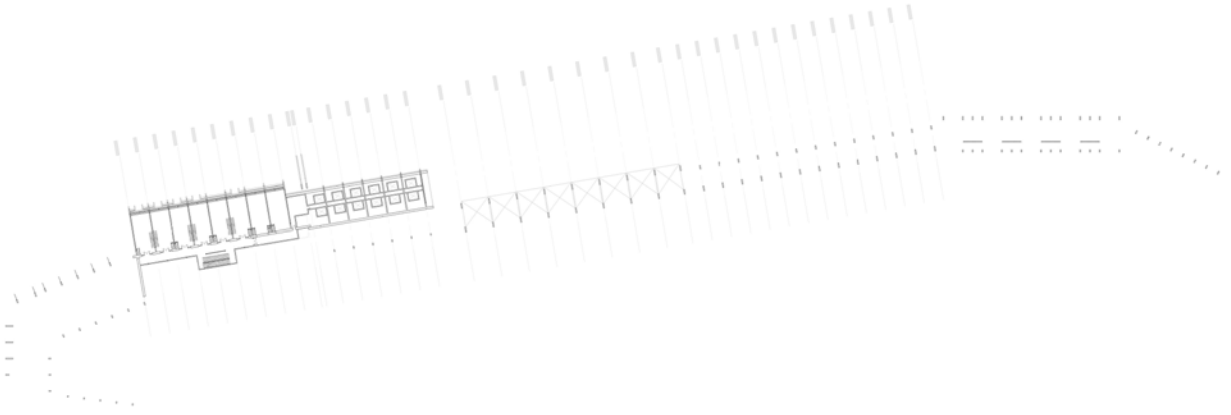


LEVEL 1
1:500



LEVEL 2
1:500





LEVEL 3
1:500

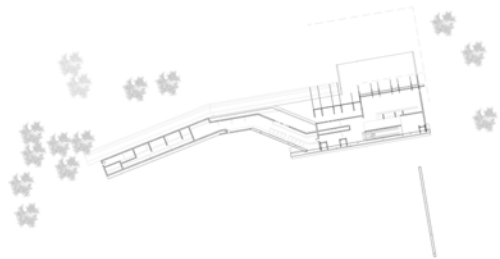


LEVEL 4
1:500

LEVEL 5
1:500



LEVEL 6
1:500



LEVEL 7
1:500



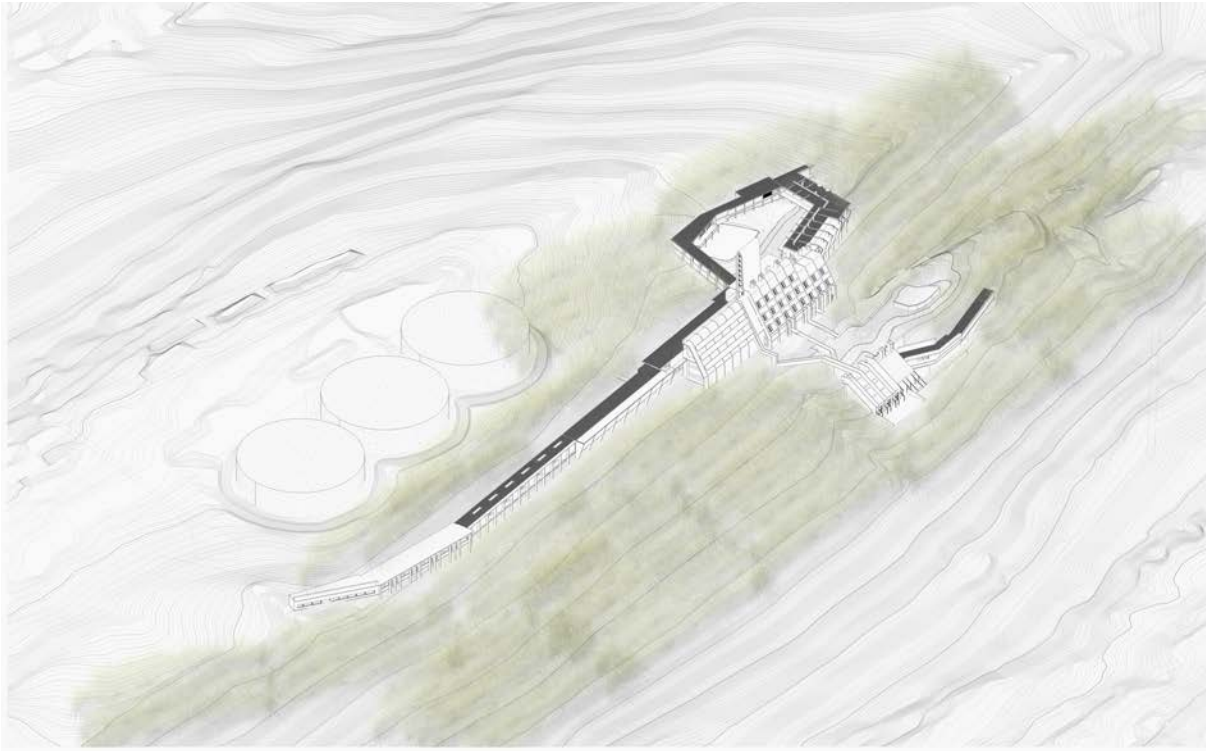


Figure 149: Three-dimensional illustration of design iteration 2 in context. (2016)

7.7.2.1. CRITICAL REFLECTION

Upon reflection of the second design iteration, the aim of the design development focused primarily on impacting minimally on the ridge's surface. The structure developed as a series of spaces, some submerged, but most are elevated and supported by a grid of pile columns. This decision was made to consider that in certain parts of the site water can flow beneath the structure on the natural topography. Other considerations were based on the quartzite geology of the ridge so that blasting can be reduced. Even though the site layout is considered appropriate based on design informants, the structure remains static and does not fulfill the objective of protection and the relationship with the human condition. Very little consideration exists regarding camouflage as part of the landscape.

Passive solar, heating and cooling strategies remain the same in the final design development but more consideration is shown relating to the concept of underground and the advantages thereof.



Figure 150: Model of design iteration 2 in context. (2016)



7.8. FINAL DESIGN ITERATION

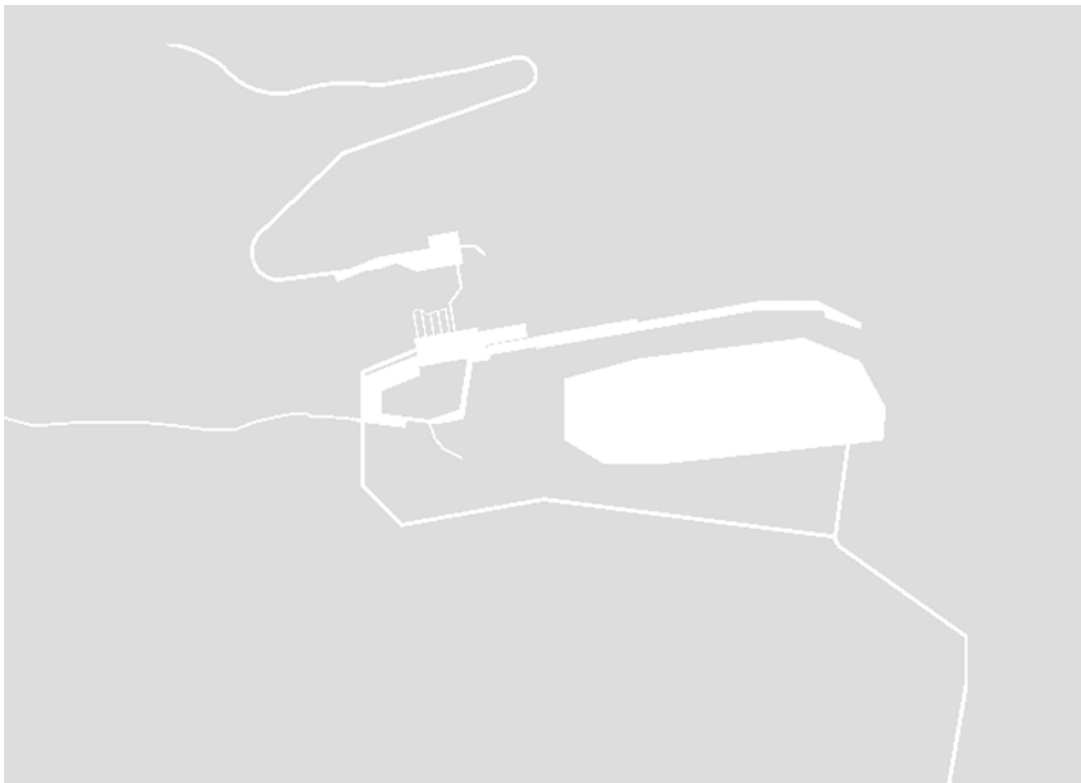


Figure 151: Parti diagram of the final development of the site layout. (2016)

In the final design iteration, the concept of underground structures is used to create and represent different functions. Some parts of the structure are elevated for observation as well as 'breathing' spaces for natural ventilation and light. The informants of design iteration one and two are utilised in a more cohesive way to create overall form. During the final design development water is considered to have an important role for the use of services, cooling and filtering of the water for irrigation of plants (structured wetlands).

The representation of space as part of the final design concept, is illustrated in the different approaches to sections as well as functions of the proposed structure. The scenarios presented earlier in the dissertation play a key role in the production of activities throughout the structure, however these scenarios remain theoretical and only present the hierarchy of people and responsibilities allocated to the different characters.

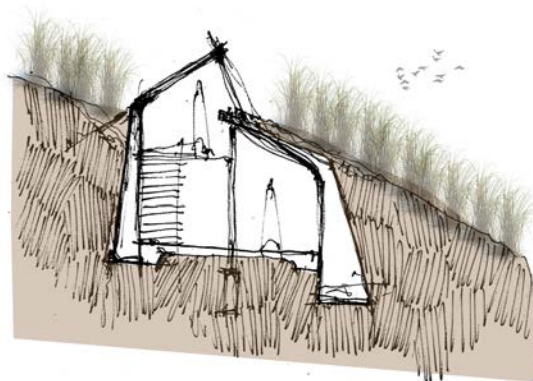
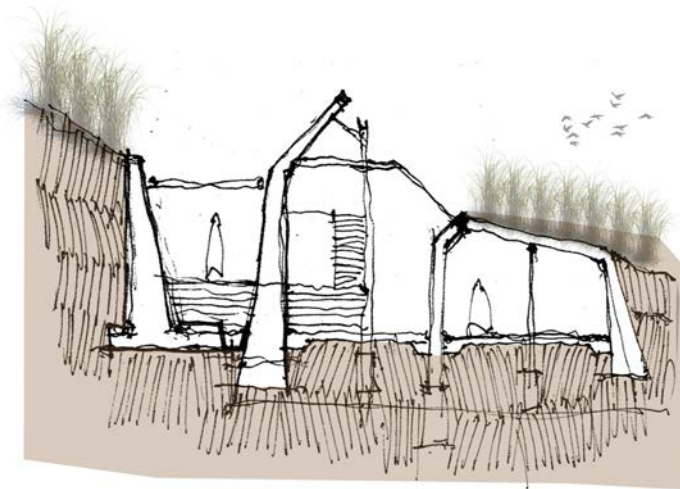
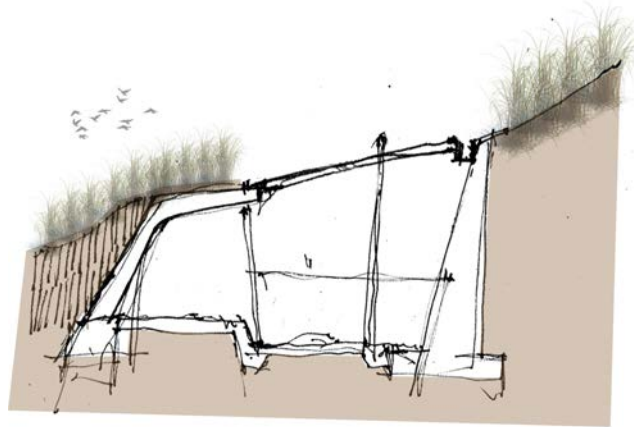
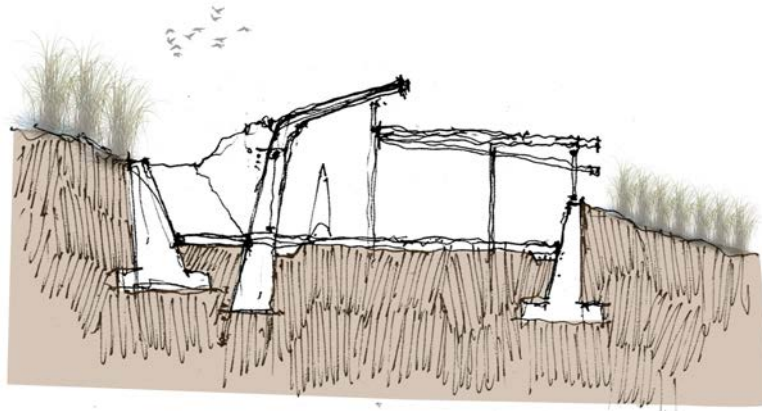


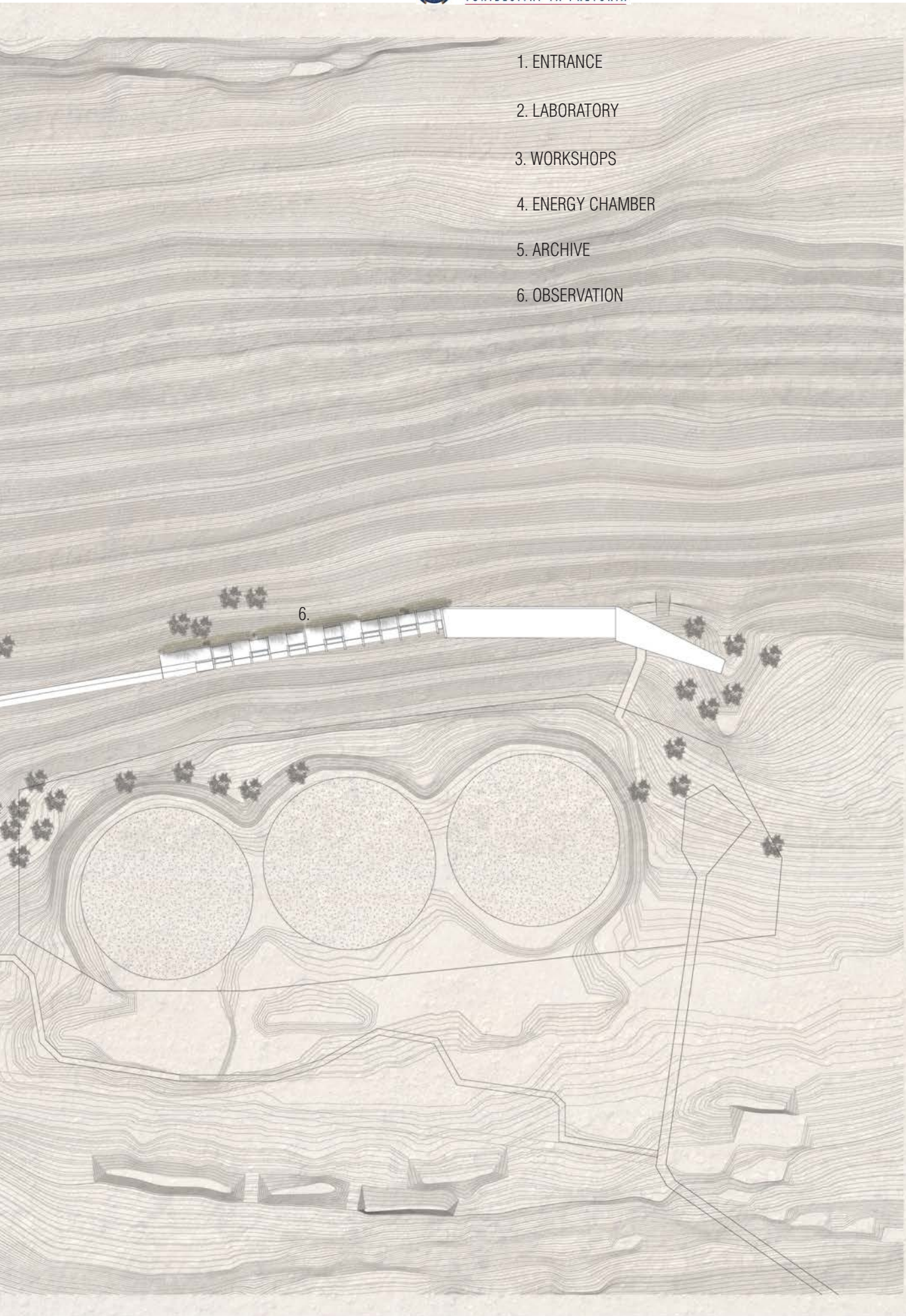
Figure 152: Sectional explorations of final design development. (2016)



Figure 153: Final site layout. (2016)



1. ENTRANCE
2. LABORATORY
3. WORKSHOPS
4. ENERGY CHAMBER
5. ARCHIVE
6. OBSERVATION



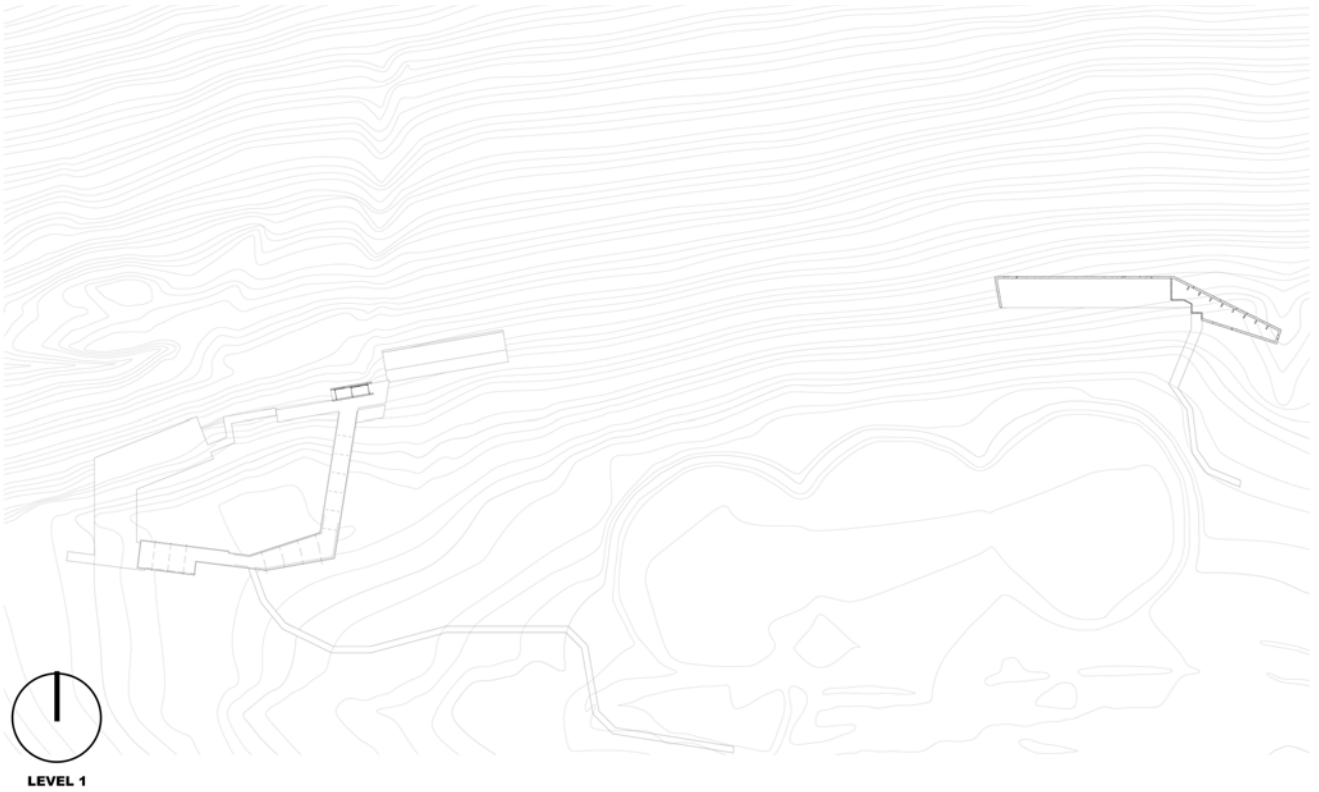


Figure 154: Level 1 layout. (2016)

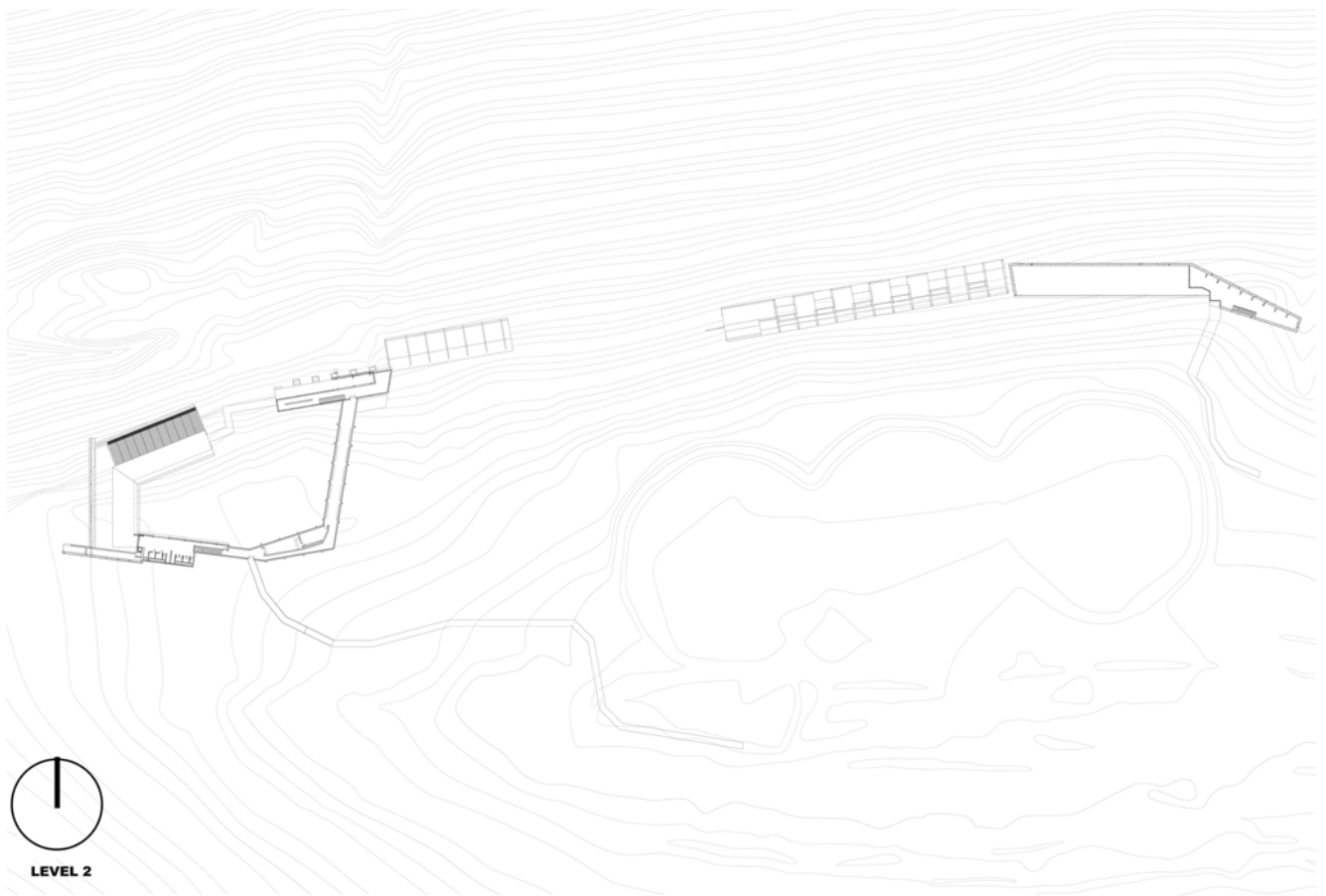


Figure 155: Level 2 layout. (2016)

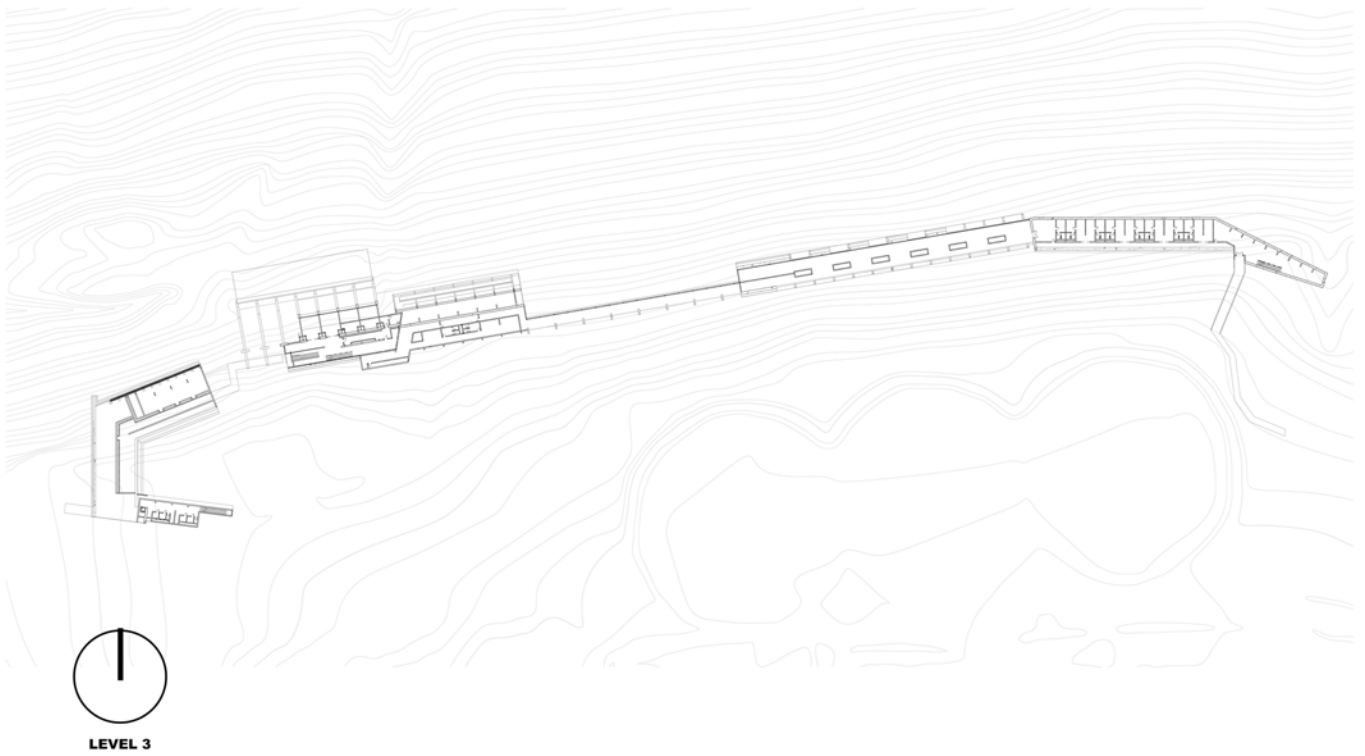


Figure 156: Level 3 layout. (2016)

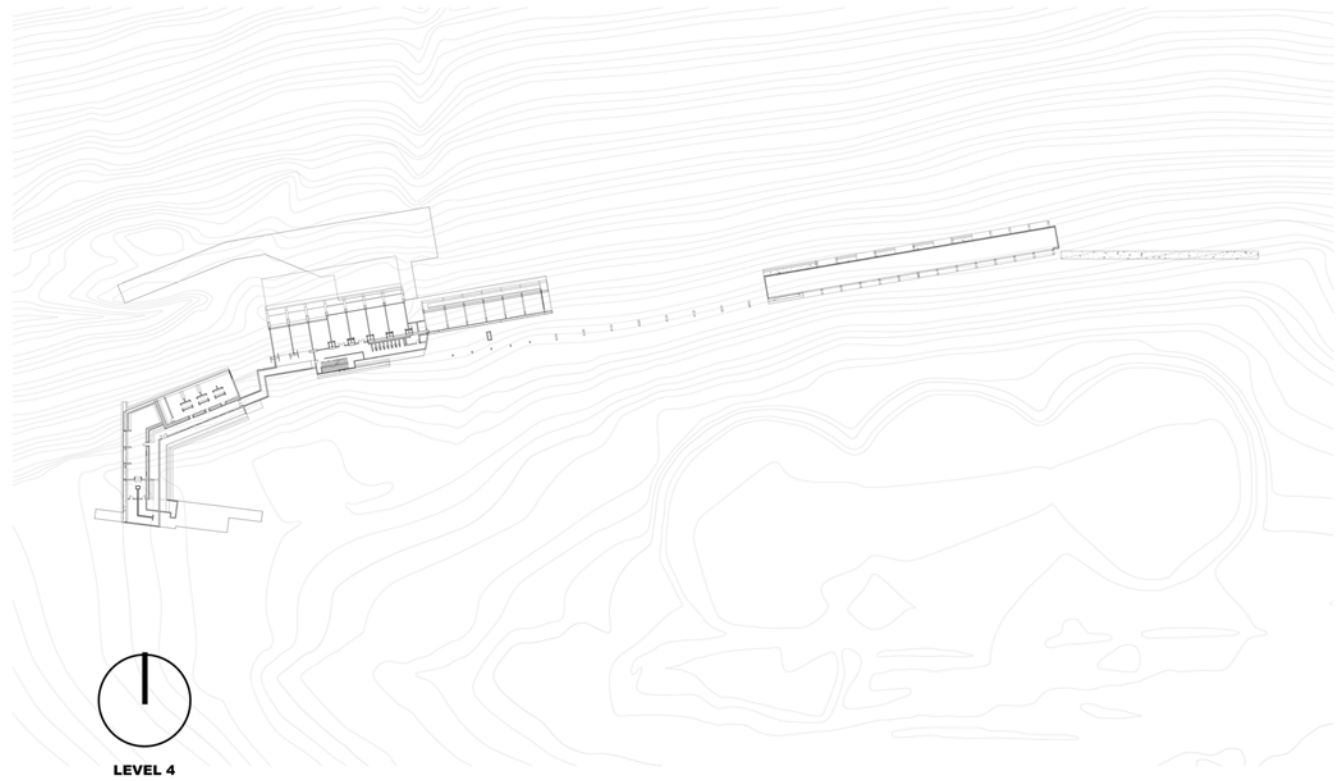


Figure 157: Level 4 layout. (2016)

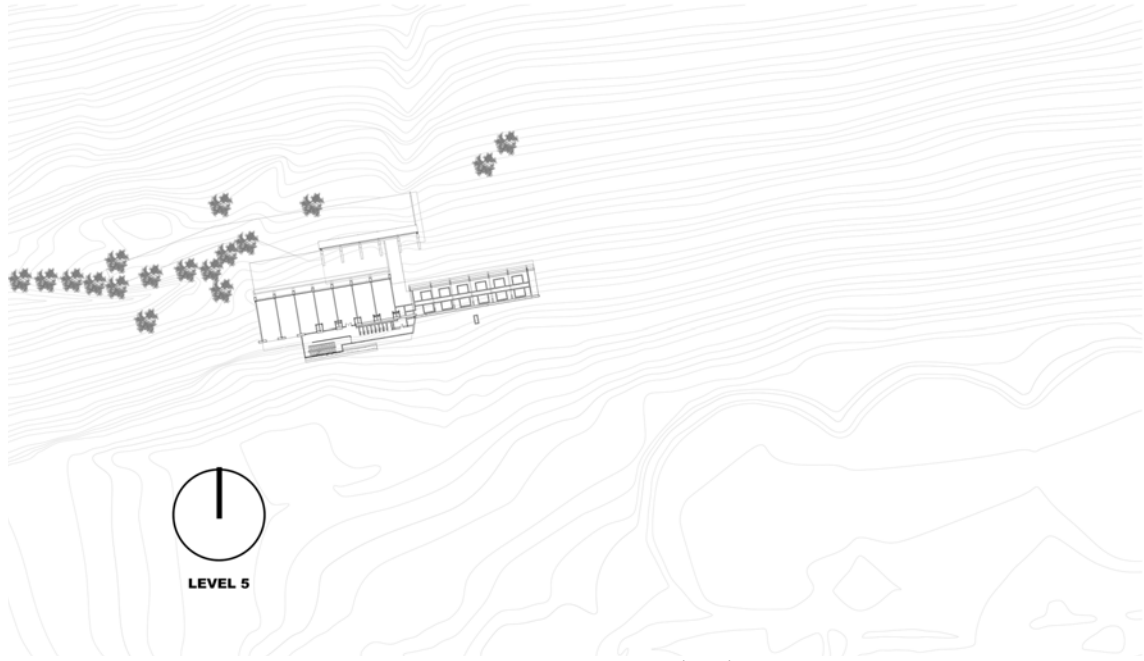


Figure 158: Level 5 layout. (2016)

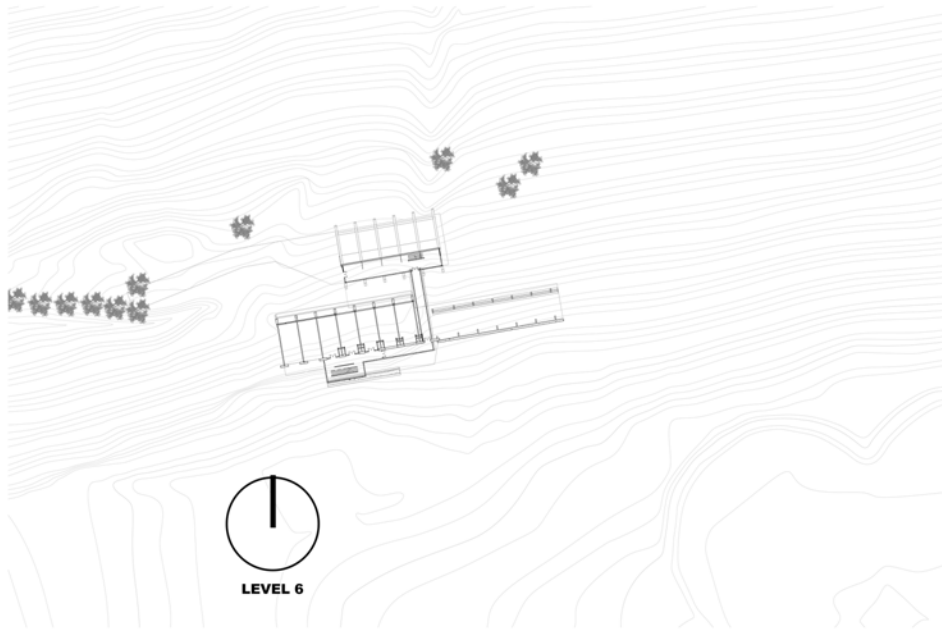


Figure 159: Level 6 layout. (2016)

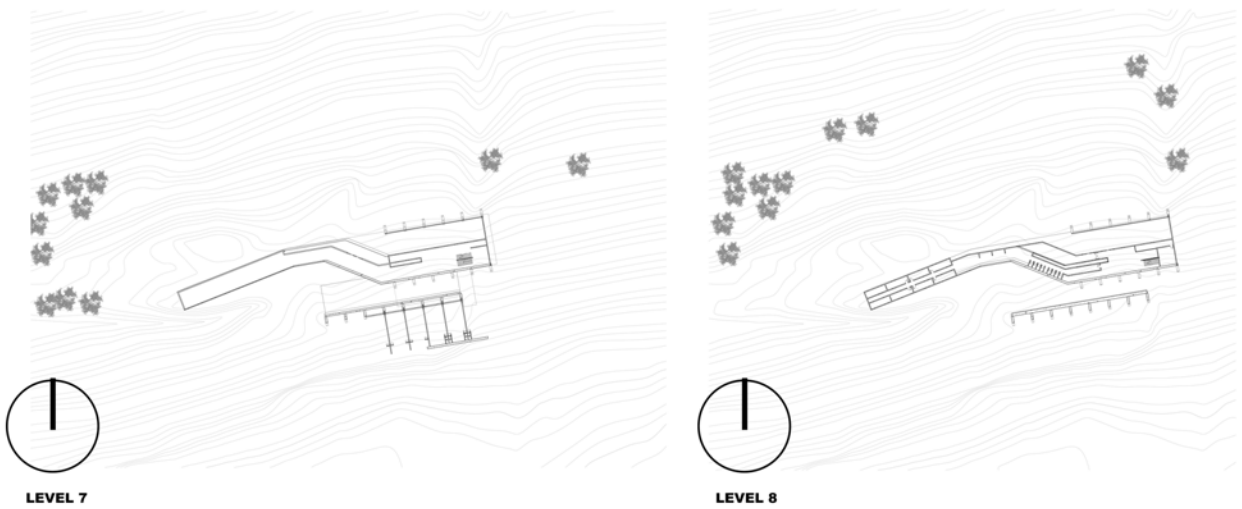


Figure 160: Level 7 and 8 layout. (2016)

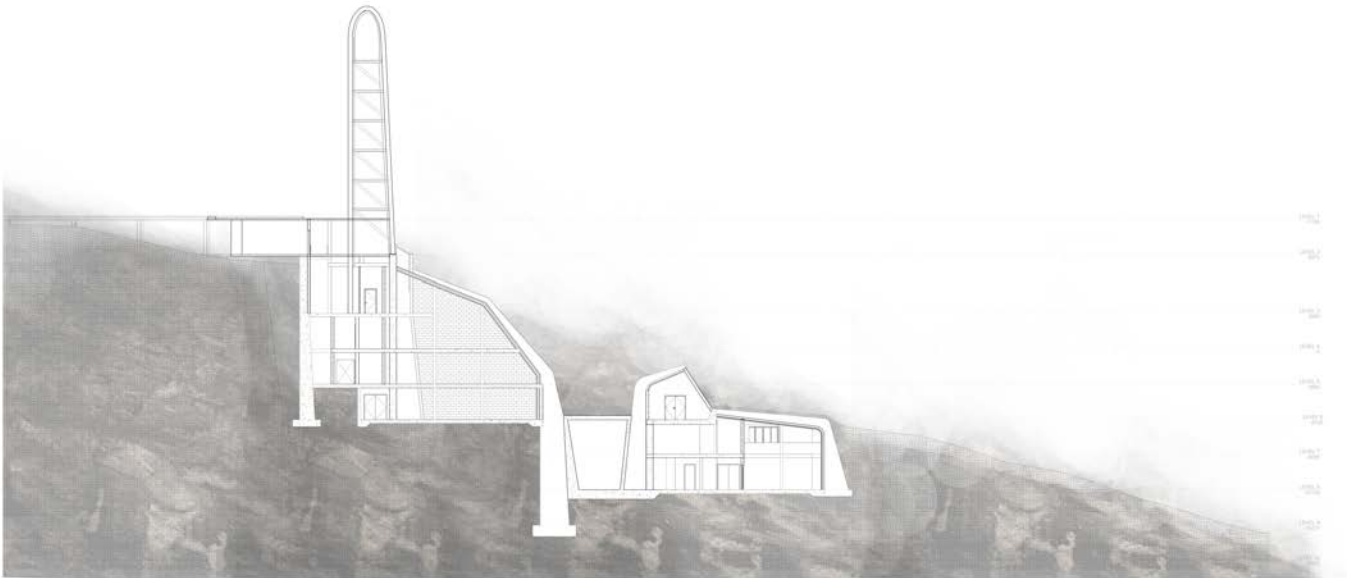


Figure 161: Section A. (2016)

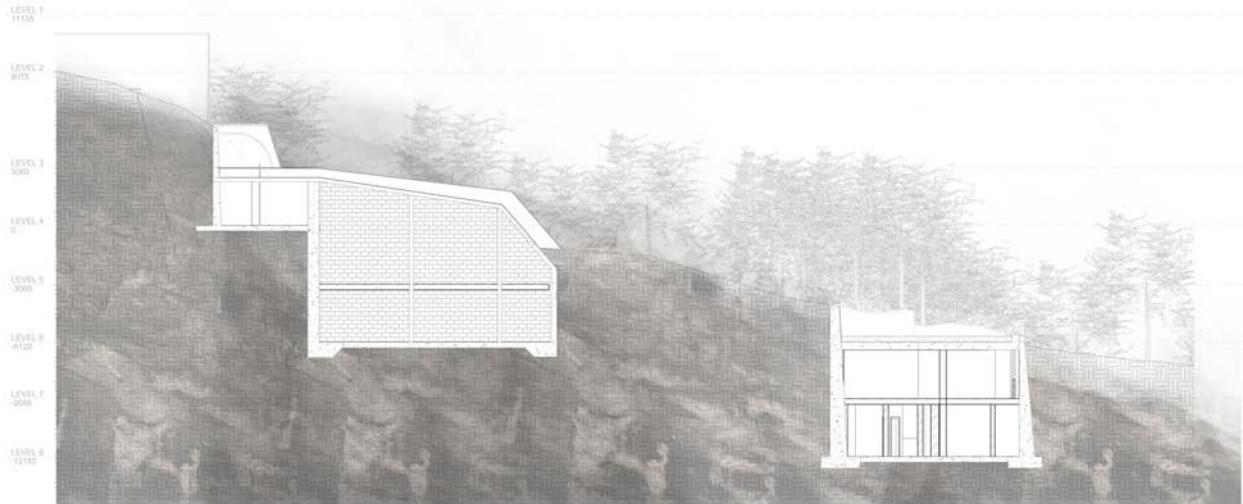


Figure 162: Section B. (2016)

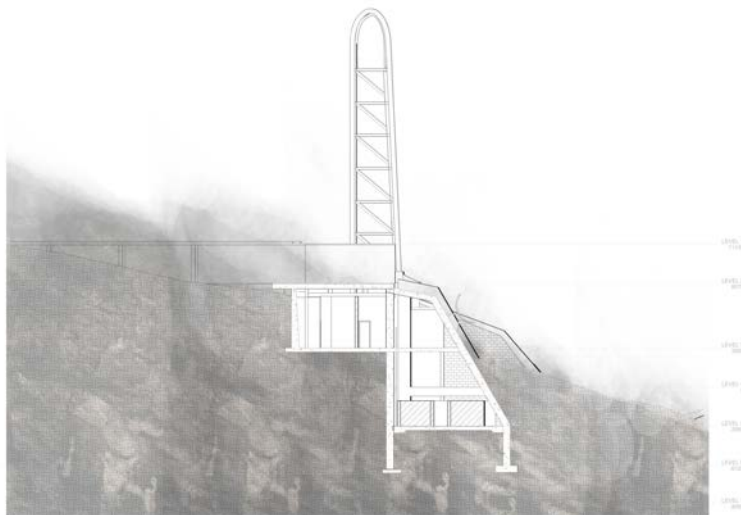


Figure 163: Section C. (2016)



Figure 164: Three-dimensional sections of the final design iteration. (2016)

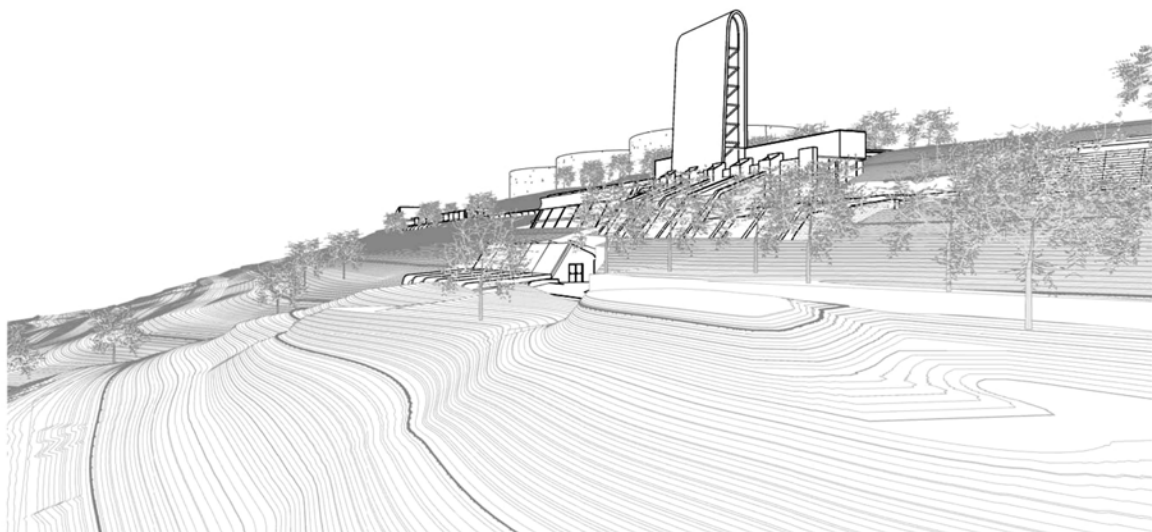


Figure 165: Three-dimensional representation of the final design resolution in its context. (2016)

7.8.1. CONCLUSION

To conclude the design development section, the final design iteration section focuses on the initial architectural objectives of mediation between landscape and structure through merging margins; shelter; protection and isolation; observation; and datum. The representation of different identities are introduced in the various approaches to sectional elements as well as the function of each of the space. Through contemplation and reflection the final design resolution does not aim for perfection but rather the interpretation of different character and their role in the making of spaces. The role of the architect is subsided in the creation of new hierarchies and power relations. The proposed structure serves to introduce a new beginning for the marginal community through which they could alter the design as they see fit. Future scenarios will be presented in the final examination as a continuation of the dissertation.