

A Skincare Servicescape for Margaret Roberts

Biomimicry and Biophilia as a Model and Mentor for Design

LEANI RADEMEYER

Department of Architecture
University of Pretoria
2016

In accordance with regulations 4(e) of the General Regulations (G.57) for dissertations and theses, I declare that his dissertation which I hereby submit for the degree Master of Interior Architecture (Professional) at the University of Pretoria, is my own work and has not been previously submitted by me for a degree at this or any other tertiary institution.

I further state that no part of this dissertation has already been or is currently being submitted for any such degree, diploma or other qualification.

I further state that this theses is substantially my own work.

Leani Rademeyer

DISSERTATION TITLE: Margaret Roberts Skincare Servicescape:
Biomimicry and Biophilia as a model and mentor for design

STUDENT: Leani Rademeyer

UNIVERSITY: University of Pretoria

FACULTY: Faculty of the Built Environment, Engineering and Information Technology

DEPARTMENT: Department of Architecture

DEGREE: Master of Interior Architecture (Professional)

RESEARCH FIELD: Environmental Potential

STUDY LEADER: Prof. Barbara Jekot

CO-STUDY LEADER: Raymund Konigk

COURSE CO-ORDINATOR: Arthur Barker

SITE LOCATION: Shop 150, Irene Mall, Pretoria

CLIENT: Margaret Roberts

Submitted in partial fulfilment of the requirements for the degree of Masters in Interior Architecture (Professional) in the Department of Architecture, Faculty of Engineering, Built Environment and Information Technology, University of Pretoria, South Africa

2016

EKSERP

Die immer veranderende aptyt van verbruikers het handelelaars genoop om tradisionele verkoopsdenke te verander en aan te pas ten einde te verseker dat “toegevoegde waarde “ ontsluit word in ‘n streng kompeterende mark.

‘n Handelsmerk word beskou as ‘n wesenlike onderskeier maar is opsigself nie voldoende om verbruikers te oortuig om die produk te bekom nie. Verbruikers verlang meer as dit. Tendense in die kontemporêre verkoops-industrie dui op kleinhandel-volhoubaarheid asook kleinhandel-ontwerp “ondervinding” as twee van die meer suksesvolle strategieë om waarde te ontsluit. Dit plaas die kleinhandel sektor se hoë hulpbron verbruik en vermorsing onder die vergrootglas. Natuurlike hulpbronne word gebruik, nie net vir die produksie van produkte nie maar ook vir die vervaardiging van verpakking, fisiese handelruimte oprigting insluitende argitektoniese struktuur, binnehuise versierings asook bybehore. Alles net om aan die einde van hul bruikbaarheidslewe afgebreek en weggegooi te word - ‘n wesenlike vermorsing.

Hierdie skrywe ondersoek die rol van die natuur as model en mentor in Handelontwerp met die fokus op die toepassing van Biomimetic en Biophilic ontwerpsbeginsels. Biomimicry word aangewend as ‘n ontwerpsinstrument in die ontwikkeling van volhoubaarheids Handels en Dienste-ontwerp wat doeltreffendheid en zero-vermorsing beginsels van die natuur najaag. Biophilic ontwerpsbeginsels word terselfde tyd ook aangewend om die aankoopondervinding in die handelsruimte te ontwikkel en verbeter volgens natuur-geinspireerde beginsels.

Margaret Roberts, ‘n vernaamde Suid Afrikaanse kruiedeskundige wat spesialiseer in kruiemedisyne, is die kliënt vir hierdie studie. Die voorgestelde ontwerp is ‘n toegepaste handelsruimte vir Margaret Roberts waar Biomimicry en Biomimetic beginsels ingespan word teneinde toegevoegde waarde te ontsluit.

ABSTRACT

The ever-increasing nature of consumer demands has forced retailers to adopt ‘added value’ strategies to ensure their competitive edge in the market. Branding is considered a market differentiator, but alone is not enough to convince consumers to make a purchase. Consumers want more. Trends in the contemporary retail industry show that retail sustainability and retail experience design are two of the most successful added value strategies employed.

This brings forth the issue of the retail sector’s resource intensive and wasteful nature. Natural resources are used to produce everything from products and packaging to the physical retail space including the architectural structure, interior finishes and fittings, all for it to be demolished and discarded as waste at the end of its life cycle.

This dissertation explores the value of nature as a model and mentor in the realm of retail design, particularly through application of Biomimetic and Biophilic design theories. Biomimicry is used as a design tool for developing a sustainable retail servicescape that emulates nature’s resource efficient and zero-waste principles. Biophilic design strategies are employed towards the development of an in-store retail experience inspired by nature.

Margaret Roberts; a well renowned South African herbalist - specialising in the art of healing with medicinal herbs, is the ‘client’ for this study. The proposed design intervention is the creation of a skincare servicescape for Margaret Roberts that integrates Biomimicry and Biophilia as an added value strategy.



The design of the Chapter Pages incorporates botanical illustrations from Margaret Roberts' published book *Indigenous Healing Plants (1984)*; highlighting the organic and natural influences that is manifested throughout this dissertation.

GLOSSARY

Atmospherics

The effort to design buying environments to produce specific emotional effects in the buyer that enhance purchase probability (Kotler, 1974).

Biomimicry

Biomimicry is an approach to innovation that seeks sustainable solutions to human challenges by emulating nature's time-tested patterns and strategies. The goal is to create products, processes, and policies—new ways of living—that are well-adapted to life on earth over the long haul (BiomimicryInstitute, 2016).

Biophilia

Hypothetical human tendency to interact or be closely associated with other forms of life in nature (Merriam-Webster, 2016).

Servicescape

The environment in which the service is assembled and in which the seller and customer interact, combined with tangible commodities that facilitate performance or communication of the service (Bitner, 1992).

TABLE OF CONENTS

Abstract	iv		
Glossary	vii		
List of Figures	x		
List of Tables	xvi		
01 INTRODUCTION		03 THE PROBLEM	
1.1 Background	5	3.1 The Real World Problem	50
1.2 The Client	6	3.1.1 The Global Problem	51
1.3 The Aim	6	3.1.2 The Environmental Impact of Building Construction	52
1.4 Contributions	6	3.2 The Design Problem	54
1.5 Research Methodology	6	3.2.1 Client Analysis	54
1.6 Outline of the Study	7	3.2.2 Existing Brand Analysis	58
		3.2.3 Margaret Roberts Brand Essence	61
		3.2.4 Site Selection	62
		3.2.5 Chosen Site	64
02 THEORETICAL INVESTIGATION		04 PROGRAMMATICAL REQUIREMENTS	
2.1 Retail Servicescapes	10	4.1 Skincare Retail Precedents	70
2.1.1 Branding	11	4.2 Skincare Retail Zones	72
2.1.2 Adding Value	13	4.3 Skincare Retail Typologies	73
2.2 Biomimicry	17	4.4 Skincare Retail Zones Analysis	74
2.2.1 Defining Biomimicry	17		
2.2.2 Levels of Biomimicry	18	05 CONCEPTUAL DEVELOPMENT	
2.2.3 Biomimicry Design Spiral	20	5.1 Application of Branding Strategies	100
2.2.4 Life's Principles	22	5.1.1 Margaret Roberts Brand Identity	100
2.2.5 Resource Efficiency in Nature	24	5.2 Application of Biomimicry	102
2.2.6 Biomimicry Precedent Studies	28	5.2.1 Discovering examples in Nature	102
2.2.7 Waste as a Resource in Nature	32	5.3 Application of Experiential & Biophilia Design Theory	106
2.2.8 Biomimicry Precedent Studies	34		
2.3 Experiential & Biophilia Design Theory	36		
2.3.1 Atmospheric	36		
2.3.2 Experiential Design Tools	38		
2.3.3 Biophilic Sensory Experience	40		

06 DESIGN DISCOURSE

6.1 Biomimicry Design Application	112
6.1.1 Resource efficiency through emulation of biomimetic forms	112
6.1.2 Waste management through emulation of biomimetic systems	124
6.1.3 Energy efficiency through emulation of biomimetic processes	128
6.2 Biophilia Design Application	130
6.2.1 Experiential Design Strategy	130
6.3 Spatial Layout Design	142
6.3.1 Floor Plan Layout Iteration 1	142
6.3.2 Floor Plan Layout Iteration 2	144
6.3.3 Final Plan Layout	146
6.3.4 Section A-A	147

07 TECHNICAL INVESTIGATION

7.1 Technification of Plans	150
7.2 Material Palette	158
7.3 Services	159
7.3.1 Acoustics	159
7.3.2 Daylight Strategy	160
7.3.3 Passive Ventilation Strategy	162
7.4 Detail Investigation of Display Design	165
7.5 Environmental Potential Assessments	178
7.5.1 GBCSA Green Star Rating	178
7.5.2 SBAT Rating	180

08 CONCLUSION

List of References	186
List of Figure References	188
Appendix A	190
Appendix B	194

LIST OF FIGURES

Figure 1.1 Diagram showing thesis theoretical approach (Author, 2016)	5
Figure 2.1. Origin of Branding: Showing the process of branding cattle (Library of Congress, 1905).	11
Figure 2.2. Brand Identity Diagram (Author, 2016) compare with (Duffy, 2005)	11
Figure 2.3. Kaferer's Brand Identity Prism: Showing how a brand identity is developed (Kapferer, 2012).	12
Figure 2.4. The Four Realms of an Experience: (Author) compare with (Pine & Gilmore, 1999).	14
Figure 2.5. Succulent Garden showing Biomimicry Inspiration (Margolis, 2016)	16
Figure 2.6. Biomimicry Inspiration: Form - Collage (AskNature, 2016)	18
Figure 2.7. Biomimicry Inspiration: Process - Collage (AskNature, 2016)	19
Figure 2.8. Biomimicry Inspiration: Systems (AskNature, 2016)	19
Figure 2.9. Biomimicry Design Spiral (Author, 2016).	20
Figure 2.10. Botanical imagery of plant life (Etsy, 2007).	21
Figure 2.11. Biomimicry Life's Principles Diagrams (Author, 2016).	22
Figure 2.12. Material configuration in Nature: Wood Weave (Flickriver, 2006).	24
Figure 2.13. Biomimicry Life's Principles (Author, 2016) compare with (Biomimicry, 2014).	24
Figure 2.14. Minimum Inventory/Maximum Diversity System (Pearce, 1978: xii).	25
Figure 2.15 (Above) Form as a diagram of forces (Author, 2016) compare with (Pearce, 1978: xiv).	26
Figure 2.16 (Right) Lightweight structures in nature (AskNature, 2015)	26
Figure 2.17. Closest Packing in Nature: Triangulation grid connecting cells (Peace, 1978:3)	27
Figure 2.18. Stability of triangular structure (Pearce, 1978: xvii)	27
Figure 2.19 Eden Project (Perrin, 2007)	28
Figure 2.20. Photos of Eden Project (Perrin, 2007).	29
Figure 2.21 Biomimicry Pavilion Design by Andres Harris (Harris, n.d.)	30
Figure 2.22. 3D Printed Chair by Lilian Van Daal (Hogan, 2013).	31
Figure 2.23. Waste Equals Food: Growth of fungi (StudioChoo, 2010)	32
Figure 2.24 Biological and Technical Metabolism (McDonough & Braungart, 2002)	33
Figure 2.25. Closed-Loop Coffee Farm (AskNature, 2015).	34
Figure 2.26. Cardboard to Caviar Closed-Loop System (Bradley, 2016)	35
Figure 2.27 Atmospheric and sensory experience diagram (Author, 2016).	36
Figure 2.28. Sensory Experience Diagram (Author, 2016).	38
Table 2.3 Biophilic Design Patterns (Author, 2016) compare with (Browning, 2014).	39
Figure 2.29. Visual Sensory Experience (Browning, 2014; Pixel, 2013).	41
Figure 2.30. Lighting design influences on atmospheric qualities (Author, 2016).	42
Figure 2.41. Daylight psychological influences (Author, 2016) compare with (Gombikova, 2014).	42
Figure 2.42. Correlated Colour Temperature & Associative Meanings (Author, 2016).	42
Figure 2.43. Tree Fractal Pattern (Shiffman, 2010)	43

Figure 2.44. Influence of form on atmospheric qualities (Author, 2016).	43
Figure 2.45. Auditory Connection with Nature: Water, wind, birds etc (Kostreva, 2016).	44
Figure 2.46. Tactile Stimuli: Natural textures (Schmidt, 2016)	45
Figure 2.5.8: Non-Visual Connection with Nature: Tactile Experience (Author, 2016)	45
Figure 2.47. Olfactory Sensory Stimuli: Oil Diffuser (Gardeners, 2016)	46
Figure 2.48. Gustatory Sensory Stimuli: Fresh Herbs and Fruit (Cochrane, 2015; Verdina, 2013)	47
Figure 3.1. Environmental degradation (Fetrow, 2011)	50
Figure 3.2. Tap and Sink Analogy: Showing resources consumed and waste produced (Author, 2016)	51
Figure 3.3. Environmental impact of building construction (Author, 2016).	53
Figure 3.4. Client: Margaret Roberts (Margaret Roberts, n.d).	54
Figure 3.5. Margaret Roberts Herbal Centre (Author, 2016).	55
Figure 3.7. Margaret Roberts product range (Author, 2016).	56
Figure 3.6 Lavandula X Intermedia (Author, 2016).	56
Figure 3.8. Lavender Straw Waste (Snowy River Lavender, 2016).	57
Figure 3.9. Diagram of Lavender essential oil distillation process (Author, 2016).	57
Figure 3.10. Margaret Robert's current product branding (Author, 2016).	58
Figure 3.11. Margaret Robert's existing store (Author, 2016).	58
Figure 3.12 Margaret Roberts' published material (Roberts, 1984).	59
Figure 3.13. Margaret Roberts Herbal Centre: Lavender Walk Way (Author, 2016).	60
Figure 3.14. Margaret Roberts brand essence diagram (Author, 2016).	61
Figure 3.15. Waterkloof Corner Shopping Centre (Author, 2016; Advanced Building, 2012).	62
Figure 3.16. Southdowns Shopping Centre (Southdowns, 2016).	63
Figure 3.17. Southdowns Shopping Centre (Southdowns, 2016).	63
Figure 3.18. Irene Shopping Centre location map (Author, 2016).	64
Figure 3.19. Irene Shopping Centre (Author, 2016).	64
Figure 3.20. Irene Shop 150 (Author, 2016).	65
Figure 3.21. Irene Shopping Centre Mall Map - Indicating location of Shop 150 (Author, 2016).	65
Figure 3.22. Shop 150 Floor plan and Section (Author, 2016).	66
Figure 3.23. Shop 150 Existing facade (Author, 2016).	67
Figure 4.1 Jurlique skincare store design (Jurlique, 2016).	70
Figure 4.2 Dermalogica skincare store (Dermalogica, 2016).	70
Figure 4.3. Aesop skincare store (Aesop, 2016).	71
Figure 4.4 Aesop skincare store floor plan 1 (Aesop, 2016).	71
Figure 4.5. Aesop skincare store floor plan 2 (Aesop, 2016).	71
Figure 4.6. Skincare Retail Zones (Author, 2016).	72

Figure 4.7. Skincare Retail Typologies (Author, 2016).	73
Figure 4.8. Facade design programmatic requirements (Author, 2016).	74
Figure 4.9. Facade design visual access (Author, 2016) compare with (Panero & Zelnik, 1979).	74
Figure 4.10. Facade Design precedent study (Author, 2016; Aesop, 2016).	75
Figure 4.12. Vertical display ergonomic requirements (Author, 2016) compare with (Panero & Zelnik, 1974).	76
Figure 4.11. Vertical display programmatic requirements (Author, 2016) compare with (Panero & Zelnik, 1979).	76
Figure 4.13. Vertical display precedent study (Author, 2016; Aesop, 2016).	77
Figure 4.14. Floor display programmatic requirements (Author, 2016).	78
Figure 4.15. Floor display ergonomic requirements (Author, 2016) compare with (Panero & Zelnik, 1979).	78
Figure 4.16. Aesop Floor display design drawing (Aesop, 2016).	79
Figure 4.17. Floor display precedent study (Author, 2016; Aesop, 2016).	79
Figure 4.18. Product testing programmatic requirements(Author, 2016).	80
Figure 4.19. Product testing ergonomics requirements (Author, 2016) compare with (Panero & Zelnik, 1979).	80
Figure 4.20. Aesop product testing area (Author, 2016; Aesop, 2016).	81
Figure 4.21. Service counter programmatic requirements (Author, 2016).	82
Figure 4.22. Service counter ergonomics (Author, 2016) compare with (Panero & Zelnik, 1979).	82
Figure 4.23. Aesop and Dermalogica Skin Bar (Author, 2016; Aesop, 2016; Dermalogica, 2016).	83
Figure 4.24. Reception / point of sale programmatic (Author, 2016)	84
Figure 4.25. Reception / point of sale ergonomics (Author, 2016) compare with (Panero & Zelnik, 1979).	84
Figure 4.26. Point of sale precedent study (Author, 2016; Aesop, 2016).	85
Figure 4.27. Waiting area programmatic requirements (Author, 2016).	86
Figure 4.28. Waiting area ergonomic requirements (Author, 2016) compare with (Panero & Zelnik, 1979).	86
Figure 4.29. Waiting area precedent study (Author, 2016; Architonic, 2013).	87
Figure 4.30. Treatment area programmatic requirements (Author, 2016).	88
Figure 4.31. Treatment area ergonomic requirements (Author, 2016) compare with (Panero & Zelnik, 1979).	88
Figure 4.32. Semi-Private treatment area precedent study: Dermalogica (Author, 2016; Dermalogica, 2016).	89
Figure 4.33. Private treatment area programmatic requirements (Author, 2016)	90
Figure 4.34. Private treatment area ergonomic requirements (Author, 2016) compare with (Panero & Zelnik, 1979).	90
Figure 4.35. Private treatment area precedent study: Dermalogica & Aesop (Author, 2016; Aesop, 2016; Dermalogica, 2016).	91
Figure 4.36. Kitchenette programmatic requirements (Author, 2016).	92
Figure 4.37. Kitchenette ergonomic requirements (Author, 2016) compare with (Panero & Zelnik, 1979).	92
Figure 4.38. Kitchenette precedent study (Author, 2016; Howarth, 2015).	93
Figure 4.39. Accessible toilet programmatic requirements (Author, 2016).	94
Figure 4.40. Accessible toilet ergonomic requirements (Author, 2016) compare with (Panero & Zelnik, 1979).	94
Figure 4.41. Shower facilities ergonomic requirements (Author, 2016) compare with (Panero & Zelnik, 1979).	95
Figure 4.42. Ablution facilities precedent study (Author, 2016; Howarth, 2015).	95
Figure 4.43. Storage area functional requirements (Author, 2016).	96

Figure 4.44. Storage area ergonomic requirements (Author, 2016) compare with (Panero & Zelnik, 1979).	96
Figure 4.45. Examples of standard storage shelving (Author, 2016; Bunnings, 2016).	97
Figure 5.1. Diagram showing relationship between Retail, Biomimicy and Biophilic approach. (Author, 2016)	100
Figure 5.2. Margaret Roberts botanical sketches (Roberts, 1984)	101
Figure 5.3. Lavender triangulated cell structure (Author, 2016).	102
Figure 5.4. Al Bahar Towers (Teicu, 2012).	103
Figure 5.5. Kolding Campus (Ongreening, 2016).	103
Figure 5.6. Lavender Closed-Loop System (Author, 2016).	104
Figure 5.7. Eastgate Centre, Harare (Doan, 2012).	105
Figure 5.8. Diagram: Passive Systems (Author, 2016).	105
Figure 5.9. Experience design diagram (Author, 2016).	106
Figure 5.10. Experiential design journey (Author, 2016).	106
Figure 5.11. Diagram showing map of experiential design journey (Author, 2016).	107
Figure 6.1 Concept development sketch (Author, 2016).	110
Figure 6.2. Diagram of Design Strategy (Author, 2016)	111
Figure 6.3. Sketch of triangulation patterns in lavender cell structure (Author, 2016)	112
Figure 6.4. Triangulated grid structure (Author, 2016)	112
Figure 6.5. Triangulated grid structure - fractal patterns (Author, 2016)	113
Figure 6.6. Triangulated grid structure - display design (Author, 2016)	113
Figure 6.7. Vertical display ergonomics (Author, 2016) compare with (Panero & Zenik, 1979)	114
Figure 6.8. Triangulated vertical display configuration 1 (Author, 2016)	114
Figure 6.9. Triangulated vertical display configuration 2 (Author, 2016)	114
Figure 6.10. 3D visualisation of display system (Author, 2016).	115
Figure 6.11. 3D Printed joinery by Minale-Madea (Homeli, 2016)	116
Figure 6.12. Joinery design (Author, 2016)	117
Figure 6.13. 5 Different joinery components (Author, 2016)	117
Figure 6.14. Resonant Chambers (Furuto, 2012).	118
Figure 6.15. Human Skin cell structure (Author, 2016).	118
Figure 6.16. Triangulated membrane (Author, 2016).	118
Figure 6.17. SHIZEN Packaging (Lin, 2014).	120
Figure 6.18. Triangulated packaging design (Author, 2016).	121
Figure 6.19. Triangulated packaging design (Author, 2016).	121
Figure 6.20. Packaging die lines (Author, 2016).	122
Figure 6.21. Product packaging design (Author, 2016).	122
Figure 6.22. Product label design (Author, 2016).	123
Figure 6.23. Lavender straw to create fiber composite boards and biodegradable packaging material (Author, 2016).	124
Figure 6.24 Biodegradable Food Packaging (DesignandPaper, 2013)	124

Figure 6.25. Coconut fiber composite (Sharpe, 2013)	124
Figure 6.26. Bamboo fiber composite column (Hartford, 2012)	124
Figure 6.27. Closed-loop system design (Author, 2016).	125
Figure 6.28. Lavender harvesting (VivreDemain, 2016).	126
Figure 6.29. Lavender paper making process (Author, 2016).	127
Figure 6.30. Shadow study (Author, 2016).	128
Figure 6.31. Diagram showing passive systems design (Author, 2016).	129
Figure 6.32. Biophilic sensory experience (Author, 2016).	130
Figure 6.33. Diagram showing layout of retail zones for referral with Table 6.1 (Author, 2016).	130
Figure 6.34. Diagram showing zoning of facade (Author, 2016).	132
Figure 6.35. Window display design (Author, 2016).	132
Figure 6.37. Call out of vertical display design (Author, 2016).	134
Figure 6.36. Diagram showing zoning of vertical display area (Author, 2016).	134
Figure 6.39. Precedent Study: Aesop laboratory glassware in store design (Aesop, 2016).	136
Figure 6.38. Diagram showing zoning of floor display area (Author, 2016).	136
Figure 6.45. Diagram showing zoning of floor skin bar area (Author, 2016).	138
Figure 6.46. Call out of vertical display design behind Skin Bar (Author, 2016).	138
Figure 6.41. Call out of POS/Reception area (Author, 2016).	140
Figure 6.40. Diagram showing zoning of POS/Reception area (Author, 2016).	140
Figure 6.42. Diagram of circulation through space of Spatial Layout Iteration 1 (Author, 2016).	142
Figure 6.43. Spatial layout design iteration 1 (Author, 2016).	142
Figure 6.44. Spatial layout design iteration 1 (Author, 2016).	143
Figure 6.45. Spatial layout design iteration 2 (Author, 2016).	144
Figure 6.46. Spatial layout design iteration 2 (Author, 2016).	144
Figure 6.47. Sketches of spatial layout design iteration 2 (Author, 2016).	145
Figure 6.48. Iterated Ground Floor and Mezzanine Plans (Author, 2016).	146
Figure 6.49. Section A-A Design(Author, 2016).	147
Figure 7.1. Iterated Ground Floor Plan (Author, 2016)	150
Figure 7.2. Iterated Mezzanine Plan (Author, 2016).	151
Figure 7.3. Facade Design (Author, 2016)	152
Figure 7.4 Iterated Section A-A showing relationship between zones (Author, 2016)	153
Figure 7.5. Iterated Section B-B showing vertical display (Author, 2016)	154
Figure 7.6 Perspective of Entrance (Author, 2016).	155
Figure 7.7. Air plants planting strategy (Author, 2016).	156
Figure 7.7. Perspective of point of view from Mezzanine (Author, 2016).	157
Figure 7.8. Collage of material selection (Author, 2016).	158

Figure 7.9. Diagram showing acoustic considerations (Author, 2016).	159
Figure 7.11. Solatube image and specifications (Solatube, 2016).	160
Figure 7.10. Diagram showing passive lighting strategy (Author, 2016).	160
Figure 7.12. Artificial lighting plan (Author, 2016).	161
Figure 7.13. Diagram showing passive systems design (Author, 2016).	162
Figure 7.14. Artificial lighting plan (Author, 2016).	163
Figure 7.15. Packaging within display system (Author, 2016).	165
Figure 7.16. (Left) Vertical Display Grid (Author, 2016).	165
Figure 7.17. Axonometric of Vertical Display (Author, 2016).	165
Figure 7.18. Iteration of connection joints and display panels (Author, 2016).	166
Figure 7.19. Detailing of connection joints (Author, 2016).	167
Figure 7.20. Detailing of 'Kit of Parts' (Author, 2016)	168
Figure 7.21. Axonometric of vertical display to wall connection (Author, 2016).	170
Figure 7.22. Section through vertical display (Author, 2016).	171
Figure 7.23. Detail 1: Vertical display Connection detail (Author, 2016)	172
Figure 7.24. Detail 1: Front Elevation (Author, 2016).	173
Figure 7.25. Detail 2: Vertical display wall connection (Author, 2016)	174
Figure 7.26. Detail 3: Dry wall connection (Author, 2016).	175
Figure 7.27. Section through vertical display (Author, 2016).	176
Figure 7.28. Section through vertical display behind Skin Bar (Author, 2016)	177
Figure 7.29. Green Star Rating score (GBCSA, 2016).	178
Figure 7.30. SBAT Rating Score (SBAT, 2016).	180

LIST OF TABLES

Table 2.1. Economic Differentiators (Author, 2016) compare with (Pine & Gilmore, 1999).	14
Table 2.2. Realms of Experience: Comparing the four differnt realms of experience (Author, 2016) compare with (Pine & Gilmore, 1999).	15
Table 2.3. Psychological influences of nature (Author, 2016) compare with (Browning, 2014).	40
Table 5.1 Biophilic Sensory Experience (Author, 2016).	106
Table 6.1. Summary of biophilic patterns application towards experiential design (Author, 2016).	131
Table 7.1. Green Star Rating Justification (Author, 2016).	179



INTRODUCTION

Background of Design Study

01

“You never change things by fighting the existing reality. To change something, build a new model that makes the existing model obsolete.”

– Richard Buckminster Fuller
(Pawlyn, 2011)

1.1 BACKGROUND

The environmental issues of climate change, water scarcity, waste and depletion of natural resources can no longer be ignored. Alarming, the built environment is one of the largest contributors to these issues. We as interior designers; professionals of the built environment therefore play a large role in the conservation of our natural environment. It is our moral obligation to design for a future that is environmentally sustainable, in which we become energy efficient, preserve natural resources and minimize waste.

In order to protect our natural environment, we need to learn from it. Biomimicry is an approach to sustainable design that looks for examples in nature to solve human problems. One of the major problems we are currently faced with in the built environment is the lack of resource efficiency (Pawlyn, 2011). Nature has mastered the art of sustainable design over 3.8 billion years (Benyus, 1997) and has developed the ability to design and construct large ecosystems using minimal energy and natural resources whilst producing zero waste in the process. So the question is:

How can we as interior designers use nature's design principles to become more resource efficient and produce less waste through the process of design?

This question highlights the real world problem, which will be addressed through the application of retail design. The interior design and construction of retail stores are often subject to seasonal changes in order to keep up with the latest trends. As a result of this, in-store shop fittings are commonly removed and discarded as waste to make room for the new concept designs, proving to be a highly resource inefficient and wasteful practice. Due to this, an opportunity was recognized to address the environmental issues through retail design.

The retail sector is highly dependent on branding and differentiation/added value strategies for success. Sustainability and experiential design are two of the leading added value strategies employed in the contemporary retail sector. Biophilic design is an eco-paradigm that mimics experiential qualities of nature in the built environment with the aim of reducing stress, improving well-being and expediting healing of occupants (Browning, 2014). This differs from Biomimicry, which mimics forms, processes and structures in nature as a means to create sustainable design solutions in the built environment. Biomimicry and Biophilic design, both nature-inspired design tools will be used to formulate an added value strategy that addresses sustainability and experiential design in the retail sector. This brings forth the design problem and question:

How can Biomimicry and Biophilic design be used as an added value strategy that deals with sustainability and experiential design in the retail sector?

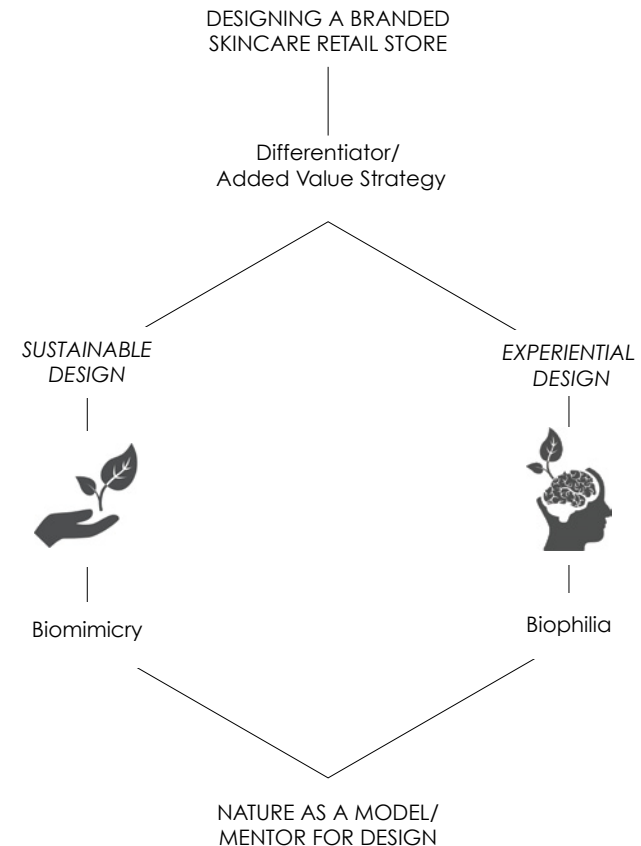

Figure 1.1 Diagram showing thesis theoretical approach (Author, 2016)

1.2 THE CLIENT

Margaret Roberts, a well-known South African herbalist has been chosen as the ‘client’ for this study. She manufactures a series of skincare products; all produced with organic medicinal herbs, which she sells at her Herbal Centre store in Hartbeespoort.

Working with Margaret Roberts as the client also provides an exciting design challenge, which is to re-brand and commercialise her products and in-store design whilst retaining the authenticity and original character about her brand image. It is evident that her current product and in-store brand image is outdated and poorly executed, which is why it is applicable for an interior design intervention to take place.

Margaret Roberts was chosen as the client for the purpose of this study since her current brand has a strong connection with nature and is in favour of sustainable practices. Therefore, the idea of designing a Biomimicry and Biophilic inspired brand and retail servicescape for Margaret Roberts is very fitting.

1.3 THE AIM

The aim of this masters study is to design a Biomimicry and Biophilic inspired skincare servicescape for Margaret Roberts that uses sustainable practices and experiential design qualities as a differentiator in the retail market.

Research Questions as Identified in Introduction

1. How can we as interior designers use nature’s design principles to become more resource efficient and produce less waste through the process of design?
2. How can Biomimicry and Biophilic design be used as an added value strategy that deals with sustainability and experiential design in the retail sector?

1.4 CONTRIBUTIONS

The application of Biomimicry in the built environment is often manifested through engineering, architecture and product design and is not well established in the discipline of interior design. This thesis will therefore contribute to developing an understanding of how Biomimicry as well as Biophilic design can be applied in the discipline of interior design.

1.5 RESEARCH METHODOLOGY

LITERATURE REVIEW

An in-depth study of Biomimicry as well as Biophilic and experiential design strategies is carried out.

PRECEDENT STUDIES

Precedent studies are used throughout this thesis as a reference point that provides examples of successful design solutions, which can be studied and analysed to support the concept design and technical development process.

MODEL BUILDING

Model building helps to develop an understanding of the three-dimensional qualities of an object or space. Since this study is largely concerned with design solutions found in nature, model building will provide a platform for dissecting these solutions and understanding the underlying structures of the design solutions.

BIOMIMICRY DESIGN SPIRAL

The Biomimicry design spiral provides two alternate methods; *Challenge to Biology* and *Biology to Challenge* that can be applied as a guideline when using Biomimicry to solve a design problem. The Challenge to Biology method is used when a human problem is identified, which then looks at examples in nature for a solution to the problem. Alternatively, the Biology to Challenge method is used when a brilliant example of design is identified in nature, which can then be applied to solve a human problem (Benyus, 1997). The **Challenge to Biology** method (see page 20) will be used for the purpose of this study since a human problem has been identified that will be addressed through finding examples of design solutions nature.

The **Challenge to Biology** approach to Biomimicry is carried out in 6 steps, namely;

DEFINE IDENTIFY INTERPRET DISCOVER ABSTRACT

These 6 steps of the Biomimicry design method will formulate the structure of this thesis and will be explained through the 1.6 *Outline of the Study*.

1.6 OUTLINE OF THE STUDY

CHAPTER 1: Introduction

Introduces the scope of this study and highlights the real world problem and design problem that is addressed.

CHAPTER 2: Theoretical Approach

This chapter discusses the application of Biomimicry in the field of design, specifically looking at the Biomimicry Design Spiral, Life's Principles and case studies of successful Biomimicry design. The theoretical approach to Biomimicry is further discussed in Chapter 5 in relation to concept development. Furthermore, Chapter 2 examines theories regarding branding, experiential and Biophilic design.

CHAPTER 3: The Problem - DEFINE

The first step of the Biomimicry Design Spiral is to Define the problem and design challenge. Therefore Chapter 3 will address both the real world problem as well as the design problem. A client analysis and site analysis is carried out as part of the investigation into the design problem.

CHAPTER 4: Programmatical Requirements - IDENTIFY

Step 2 of the Biomimicry Design Spiral is to Identify the key functions that need to be carried out by the design. Therefore, Chapter 4 defines the programmatical requirements for the Margaret Roberts skincare servicescape. This includes analysis of precedent studies as well as an in depth investigation into each of the programmatical functions.

CHAPTER 5: Conceptual Development - INTERPRET/DISCOVER

Step 3 and 4 of the Biomimicry Design Spiral is to Interpret the design problem into biological terms and to Discover examples in nature to address the design problem. For the purpose of this study, these two steps are combined into one investigative chapter, which supports the development of the design concept. Theories on resource efficiency and waste management in nature are consulted in this chapter.

CHAPTER 6: Design Development - ABSTRACT

Step 5 of the Biomimicry Design Spiral is to Abstract the elements of nature that provide a solution to the problem; as discovered in step 5, and apply them to a design solution. Chapter 6 therefore applies the theories discussed in Chapter 2 and Chapter 5 in order to formulate a design concept.

CHAPTER 7: Technical Resolution - EMULATE

The final step of the Biomimicry Design Spiral is to Emulate the design concept and to test the success of the design against Biomimicry's Life's Principles. Chapter 7 therefore involves technical investigations and iterations of design as well as the final design solution that will be tested against the Biomimicry and Biophilic design strategies.

CHAPTER 8: Conclusion

Final conclusions from the master study will be drawn and presented in this chapter.



THEORETICAL INVESTIGATION

Branded Retail Servicescapes, Biomimicry & Biophilia

This chapter forms the theoretical background for the design intervention. Firstly, retail design, branding and added value strategies are discussed, creating a foundation for the design parameters. Secondly, nature as a model and mentor for design is investigated through Biomimicry and Biophilic design principles.

02

2.1 RETAIL SERVICESCAPES

Retail design has become a discipline that involves expertise from various different professionals including architects, interior designers, graphic designers, product designers as well as web designers. The word retail refers to the selling of products to an end-user (Quartier, 2011); therefore the design of retail spaces is there to facilitate the selling of these products and services.

In his book *New Retail* (2000: 10), Rasshied Din describes the role of contemporary retail design;

“The role of contemporary retail design is to link instinct, art and commerce...to come to efficient (in terms of space, flexibility and cost) and effective (to communicate the retailer’s brand values and encourage consumer activity) retail environments that meet the ever-tougher consumer demands. It incorporates the management of people and space to meet up to the essential characteristic of retail: change. Therefore a designer’s task is to combine his expertise and the retailer’s knowledge of the market with elements of psychology, technology and ergonomics.”

Din suggests that change is one of, if not the most essential characteristic of retail design since retail spaces need to accommodate for seasonal changes, as well as the change in consumer trends over time (Din, 2000: 10). Branding is another essential pillar to retail design, which is often used as a means to distinguish different retailers in the market and to ultimately promote sales of products and services.

At the time in which retail design was in its infancy in the 1960’s, it was believed that the product was king and that the design of retail spaces merely served the purpose of complementing the product (Din, 2000). However, over the past few decades the retail space itself has become just as much apart of the product being sold and is now seen as a 3D representation of the brand and its values (Quartier, 2011). The design of a retail space should communicate a message about the products without the buyer even having a look at the merchandise. Branding of a retail space therefore serves a great purpose in the role of encouraging consumer purchases (Quartier, 2011).

Branding of products and retail spaces however has become homogenized, which is why consumers are finding it hard to make purchasing decisions based on branding alone. This has led to an increase in consumer demands - consumers are no longer satisfied with just purchasing a branded product, but are looking for added value – something to take away from the purchase other than just the product or service itself.

The rest of this chapter will specifically look at branding and added value and its significance to retail design.

2.1.1 BRANDING

What is a brand?

The term brand is Germanic in origin, which translates into the English word ‘burn’, and refers to the act of using an iron stamp to burn a mark onto farmers’ cattle (Quartier, 2011). The burn mark was a means for farmers to differentiate one herd of cattle from another and essentially became a trademark that was stamped onto steaks to be sold to consumers. These trademarks added conversational value to the steaks and would allow consumers to associate certain qualities with the different trademarks (Quartier, 2011).

This idea of a brand evolved and eventually translated into what we recognize a brand to be in contemporary society – a trademark that provides a means of differentiation between products and services (Wheeler, 2009: 2). In a world with infinite product choices, a brand allows companies to stand out amongst its competitors and to develop a relationship with its customers. People develop brand preferences and become loyal to the brands that offer them good quality products and services (Wheeler, 2009: 2).



Figure 2.1. Origin of Branding: Showing the process of branding cattle (Library of Congress, 1905).

Brand Primary Functions

NAVIGATION	REASSURANCE	ENGAGEMENT
Brands help consumers choose between a bewildering array of choices.	Brands communicate the intrinsic quality of the product or service and reassure customers that they have made the right choice.	Brands use distinctive imagery, language, and associations to encourage customers to identify with the brand.

What is Brand Identity?

In her book *Building Brand Identity* (2009: 4), Alina Wheeler defines brand identity as:

“Brand identity is tangible and appeals to the senses. You can see it, touch it, hold it, hear it, watch it move. Brand identity fuels recognition, amplifies differentiation, and makes big ideas and meaning accessible. Brand identity takes disparate elements and unifies them into whole systems.”

Brand identity can be seen as the personality of a company (Davis, 2009:12), which embodies its core values, strengths and passions (Mesher, 2010:11). It is the way in which the brand wants to be perceived in the market. Brand image on the other hand refers to the way in which the market perceives a brand in reality (Duffy, 2015). A brand strategy is the way in which the organization will communicate and deliver its brand identity to the market to ensure that the perceived brand image correlates to the projected brand identity.

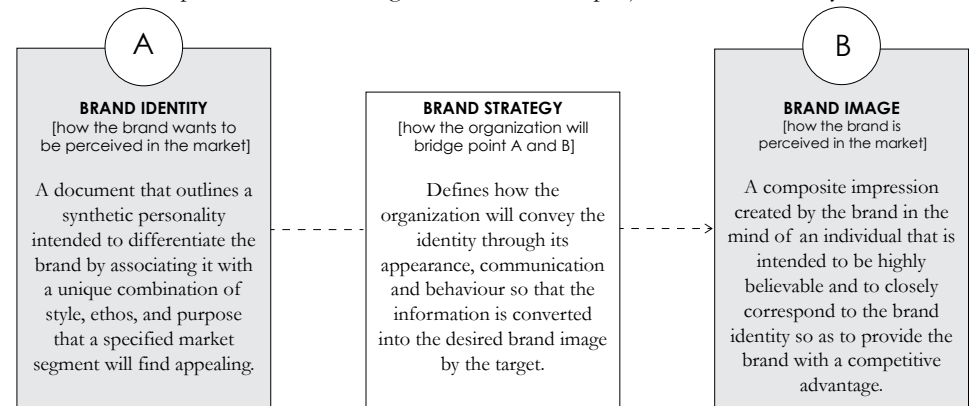

Figure 2.2. Brand Identity Diagram (Author, 2016) compare with (Duffy, 2005)

Brand Identity Prism

Corporate branding specialist Jean-Noël Kapferer has created a “Brand Identity Prism” (Kapferer, 2012) which illustrates the six different aspects of a brand identity, namely; **PHYSIQUE, PERSONALITY, CULTURE, RELATIONSHIP, REFLECTION** and **SELF-IMAGE**. According to Kapferer (2012), it is the synthesis of these six elements that creates a successful brand identity.

PHYSIQUE

Physique refers to the physical and recognizable characteristics of the brand. Such as the logo, colour scheme, packaging as well as online interfaces.

PERSONALITY

Personality is the character associated with the brand and how the brand communicates with the outside world. For instance the personality of a brand might be playful and energetic. The personality of a brand identity is communicated through the physique of the brand and the way the brand expresses itself.

CULTURE

The culture of a brand is the set of values and beliefs that a company’s behaviour is based on. For instance, the culture of Coca-Cola’s is based around socializing and sharing.

RELATIONSHIP

Relationship represents the connection that the brand aims to create between the brand and the consumer.

REFLECTION

Reflection refers to the stereotypical consumer of the brand, but does not necessarily coincide with the intended target market of the brand.

SELF-IMAGE

Self-image symbolizes the persona that the consumer sees him/herself as. Consumers often look for products and/or services that reflect their self-image.

Kapferer’s Brand Identity Prism will be used in Chapter 5 to develop a new brand identity for Margaret Roberts.

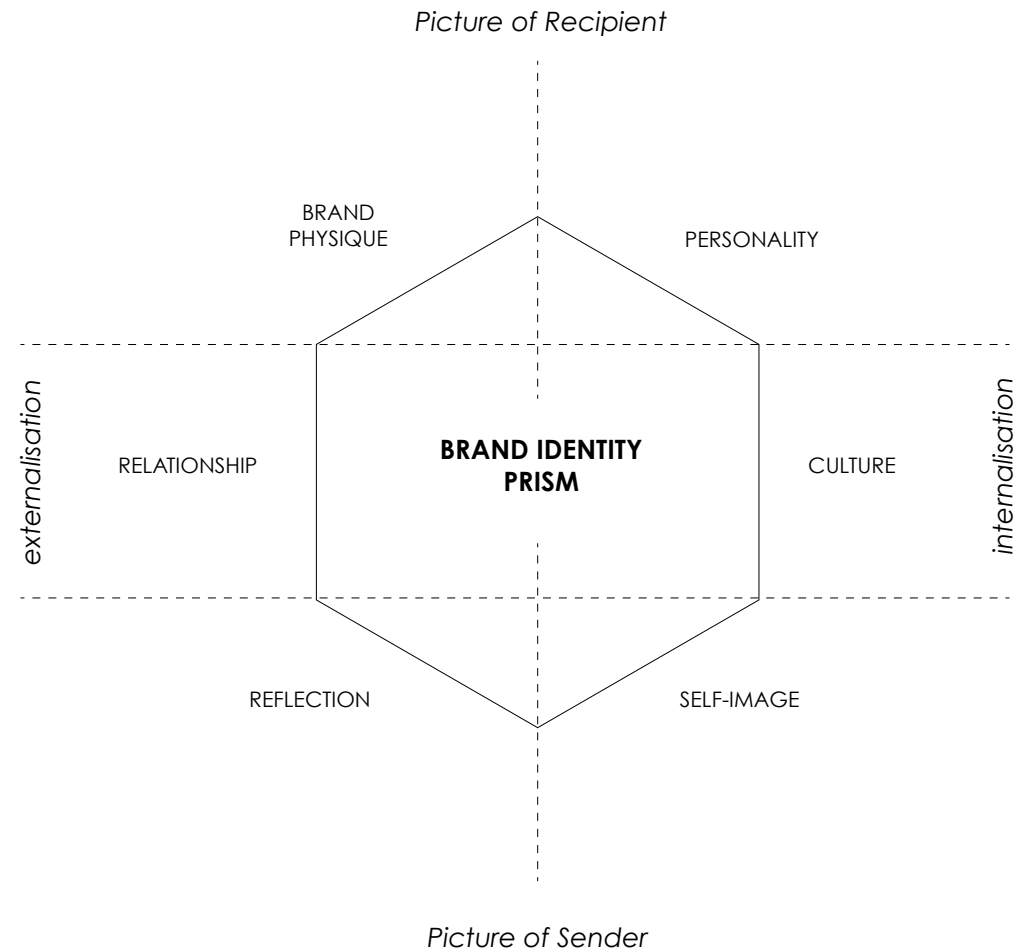

Figure 2.3. Kapferer's Brand Identity Prism: Showing how a brand identity is developed (Kapferer, 2012).

Brandscaping

Otto Riewoldt (2002) coined the term ‘brandscaping’ – referring to “*the creation of a three-dimensional microcosm representing the brand*”. In other words, brandscaping is the act of translating a brand (that is often experienced in two-dimensional form) into a three-dimensional space that clearly represents the brand identity. Mesher (2010:11) states – “*in retail terms, the store is built around the concept of the brand and the products sold within it. The interior emulates the aspirations of the brand values and qualities to enhance the relationship between the space and the message*”. Through this statement, Mesher highlights the significant role played by interior designers in creating retail spaces that reflect brand identity. The retail space should be treated as an extension of the brand and not a separate entity.

“The physical space is the only place where you have 100 percent control over the brand and the messaging and the media. So that space is and has to be the true manifestation of the brand. And because the brand eventually exists in people's minds, you have to understand it mentally, and everything you do with the physical space relates to that, then it will work.”

(Zuidhof, 2007)

2.1.2 ADDING VALUE

As previously mentioned, contemporary consumers are seeking products and services with added value. This has forced retailers to adopt new branding and retail strategies in order to ensure their competitive edge on the market. Consumer trend studies and forecasts suggest that practices of sustainability and experiential design are amongst some of the leading strategies employed by retailers to provide added value (Davis, 2009: 14).

Sustainability in Retail Design

The growing concern of environmental issues such as climate change has caused a shift in social trends in which consumers are starting to seek out products and services that are socially and environmentally responsible (Davis, 2009:14).

The Nielsen Global Survey (Adams, 2014) on Corporate Social Responsibility conducted online in 2014, polled statistics from over 30, 000 consumers spread over 60 different countries worldwide in the aim of gaining insight on the influence of corporate social responsibility, and more specifically sustainability on consumers’ purchasing behaviour. The survey hoped to find out whether consumers care enough about environmental issues in order for it to affect their purchasing decision.

The study found that 55% of global online consumers are in fact willing to pay a higher price for a product or service that is committed to creating a positive social and environmental impact (Adams, 2014). It is interesting to note that 52% of the Nielsen Global Survey participants stated that the packaging of a product and the presence of an environmentally conscious indicator on the packaging affects their purchasing decision (Adams, 2014).

For this reason, it has become essential for organizations to adapt the message of their brand towards becoming socially and environmentally responsible competitive. Part 2.2 of this chapter therefore explores the use of Biomimicry as a design tool for developing a sustainable retail design solution for the Margaret Roberts brand, which will ensure her competitive edge in the contemporary market.

The Brand Experience

Experience Economy is a term coined and published by Joseph Pine II and James Gilmore (1999) referring to a fourth level of an economic offering, the first three levels being commodity, goods and services (see table 2.1) for a comparison between the levels of economic offering and distinction). Experiences can be seen as a new source of value added to a customer's purchase of goods and services and is ultimately a means of differentiation (Pine & Gilmore, 1999: 10) between competitors in the market.

Economic Differentiators

ECONOMIC OFFERING	COMODITIES	GOODS	SERVICES	EXPERIENCES
<i>Economic Model</i>	Agrarian	Industrial	Service	Experience
<i>Economic Function</i>	Exact	Make	Deliver	Stage
<i>Nature of Offering</i>	Fungible	Tangible	Intangible	Memorable
<i>Key Attribute</i>	Natural	Standardised	Customised	Personal
<i>Method of Supply</i>	Stored in Bulk	Inventoried After	Delivered on Demand	Revealed over Duration
<i>Seller</i>	Trader	Manufacturer	Provider	Stager
<i>Buyer</i>	Market	User	Client	Guest
<i>Factors of Demand</i>	Characteristics	Features	Benefits	Sensation

Table 2.1. Economic Differentiators (Author, 2016) compare with (Pine & Gilmore, 1999).

The Four Realms of an Experience

Pine and Gilmore (1999: 30) suggest that an experience is encountered on two different dimensions – the first dimension being the level of guest participation (horizontal axis). Guest participation can be passive; where they do not directly affect the performance, or it can be active; where guests do have a direct influence on the performance. The second dimension (vertical axis) refers to the environmental relationship between customers and the event. The environmental relationship can be one of absorption – in which the guest's attention is occupied by projecting the experience in the mind of the guest. Contrary, the environmental relationship can be one of immersion – in which guests physically become part of the experience itself (Pine & Gilmore, 1999: 30).

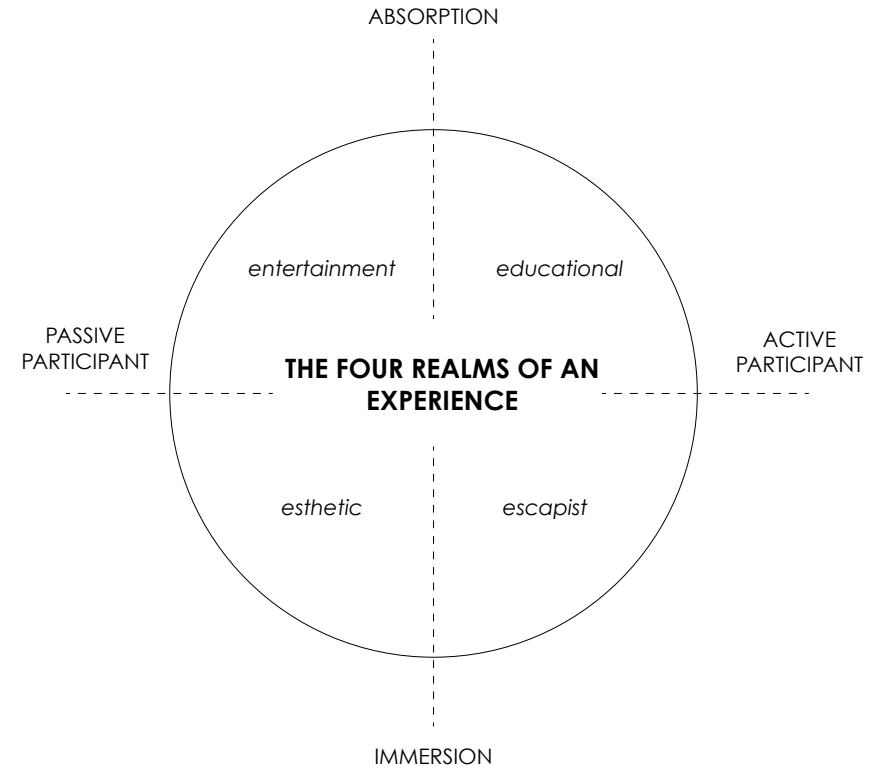

Figure 2.4. The Four Realms of an Experience: (Author) compare with (Pine & Gilmore, 1999).

The relationship between these dimensions defines the four realms of an experience – *ENTERTAINMENT*, *EDUCATION*, *ESCAPE*, and *ESTHETICISM* (Pine & Gilmore, 1999: 30). These realms can be exclusively applied to create an experience; however Pine & Gilmore (1999:31) suggest that it is the combination of these four realms that makes an experience new and exciting.

THE EDUCATIONAL

Creating an educational experience involves active participation of the guest. The purpose of this experiential realm is to inform and educate the guest, to increase his/her knowledge and skills both on an intellectual and physical level (Pine & Gilmore, 1999: 32).

Ask yourself:

What do you want your guests “to learn” from the experience?

What information or activities will help to engage them in the exploration of knowledge and skills?

THE ESCAPIST

Creating an escapist experience involves active participation of the guest in order to induce an immersive experience.

Ask yourself:

Once there, what should your guests do?

Focus on what you should encourage your guests “to do” if they are to become active participants in the experience.

THE AESTHETIC

An aesthetic experience is one of immersion but the guest does not actively participate in the experience, for instance visiting an art gallery or museum. “The aesthetics are what make your guest want to come in, sit down and hang out. Think about what you can do to make the environment more inviting, interesting, or comfortable. You want to create an atmosphere in which your guests feel free “to be”.

THE ENTERTAINMENT

Through this article Pine and Gilmore suggest that creating memorable events and experiences within a trading environment contributes directly to the success of the products being sold. Pine and Gilmore argue that businesses must orchestrate memorable events for their customers, and that memory itself becomes the product — the “experience”.

‘Experiential Interior Design’ (EID) links directly to the studies in environmental psychology that suggests that the physical environment has a significant impact on its users and inhabitants and can be used to stimulate emotional responses and ultimately affect behaviour of inhabitants (Davis, 2009:19).

EXPERIENCE REALMS	DESCRIPTION	GUEST PARTICIPATION	ENVIRONMENTAL RELATIONSHIP	EXAMPLE	GUIDING QUESTIONS
EDUCATION	The purpose of this experiential realm is to inform and educate the guest, to increase his/her knowledge and skills both on an intellectual and physical level.	Active Participation	Absorption	Interactive Science Museums	What do you want your guests “to learn” from the experience? What information or activities will help to engage them in the exploration of knowledge and skills?
ESCAPIST	The escapist realm creates an experience in which guests can ‘escape’ their reality to be completely immersed in a fantasy world.	Active Participation	Immersive	Theme Parks Casinos Chat Rooms	Once there, what should your guests do? Focus on what you should encourage your guests “to do” if they are to become active participants in the experience.
AESTHETIC	The aesthetics are what make your guest want to come in, sit down and hang out. You want to create an atmosphere in which your guests feel free “to be”.	Passive Participation	Immersive	Museum Art Gallery	Think about what you can do to make the environment more inviting, interesting, or comfortable.
ENTERTAINMENT	An entertainment experience is the act of occupying a guest’s attention in an attempt to amuse them. When your guests are entertained, they’re not really doing anything but responding to (enjoying, laughing at, etc.) the experience.	Passive Participation	Absorption	Theatre Musical Performances	What can you do by way of entertainment to get your guests “to stay”? How can you make the experience more fun and enjoyable?

Table 2.2. Realms of Experience: Comparing the four different realms of experience (Author, 2016) compare with (Pine & Gilmore, 1999).



Figure 2.5. Succulent Garden showing Biomimicry Inspiration (Margolis, 2016)

2.2 BIOMIMICRY

2.2.1 DEFINING BIOMIMICRY

Nature provides **3.85 billion years** worth of ingenious design examples that have been succumbed to **natural selection**, and as a result have been perfected over time (Benyus, 2013). Biomimicry is an eco-design paradigm that recognizes this and aims to provide a **nature-inspired design tool** for designers, architects and engineers to use when grappling with sustainable design issues in the built environment.

Founder of the design paradigm, Janine Benyus, coined the term Biomimicry in 1990. The term is a compilation of the Greek word *bios*, meaning **life** and the word *mimesis*, which means to **imitate**. Benyus defines Biomimicry as:

“...an approach to innovation that seeks sustainable solutions to human challenges by emulating nature’s time-tested patterns and strategies. The goal is to create products, processes, and policies—new ways of living—that are well-adapted to life on earth over the long haul.”

Biomimicry is often confused with similar eco-design paradigms, which is why it is also important to highlight what is not classified as Biomimicry. Harvesting of natural materials for design purposes such as timber flooring does not qualify as Biomimicry but rather bio-utilization. Biomimicry is also distinguished from bio-assisted technologies, which is the act of domesticating an organism to carry out a design function – for instance manipulating silkworms to spin enclosures onto frameworks. Biomimicry aims to learn from nature and use it as a model and mentor for design inspiration instead of taking away from nature by harvesting natural resources and exploiting organisms (Benyus, 2013).

*The more our world functions like the natural world,
the more likely we are to endure this home that is
ours, but not ours alone.*

Janine Benyus (2013)

2.2.2 LEVELS OF BIOMIMICRY

The application of Biomimicry can be achieved on three different levels namely **Form, Process** and **Systems**. Benyus (2013) suggests that it is the mimicking of all three levels of Biomimicry that successfully creates conditions conducive to life.



FORM

The first level of Biomimicry is the mimicking of **natural form**; for instance, designing a solar panel in the shape of a leaf. Mimicking of natural form achieves Biomimicry on a surface level only, which is why it is important to also mimic the processes and systems involved (Benyus, 2013).

"If we can biomimic at all three levels - natural form, natural process, and natural systems - we'll begin to do what all well-adapted organisms have learned to do, which is to create conditions conducive to life"

Benyus (2013)



SPIRAL FORMATIONS

Spiral formations in nature can be seen in plants and sea organisms and serves a specific purpose for each organism.

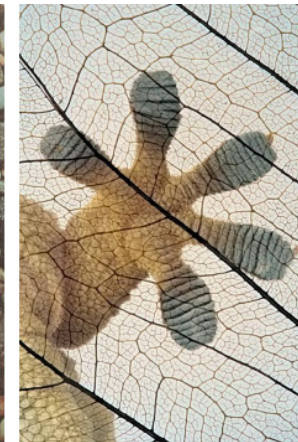

HEXAGON & TRIANGULATIONS

Hexagons and triangulations in seen in nature are resource efficient and structurally sound forms.

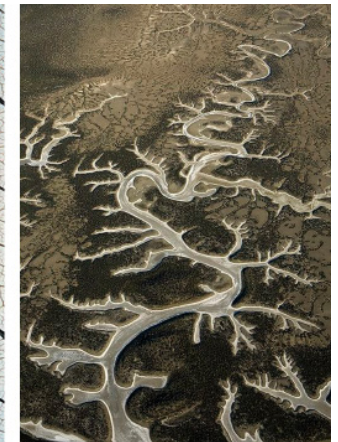

FRACTAL FORMATIONS

Fractals seen in nature are a series of geometrical patterns that follow a mathematical sequence creating beautiful patterns and forms.

Figure 2.6. Biomimicry Inspiration: Form - Collage (AskNature, 2016)

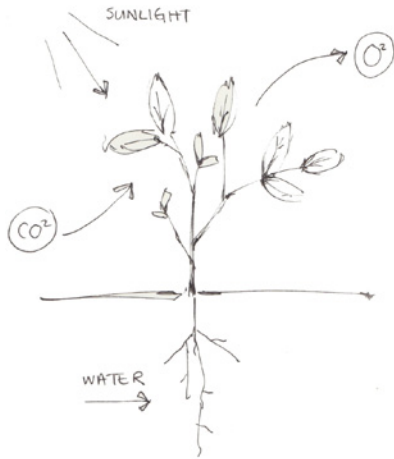

PROCESS

The second level of Biomimicry is the mimicking of **natural processes** or the way in which nature builds and produces. Photosynthesis is an example of a natural process that is carried out by plants in which renewable energy (sunlight) is used to produce nutrients from a waste product (CO₂) and water. Mimicry of photosynthesis could be in the form of a man made process in which renewable energy is harvested and waste is used as the building material (Benyus (2013).

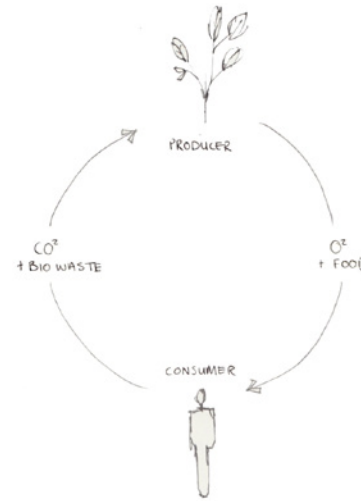

SYSTEM

The third level of Biomimicry is mimicking of **natural ecosystems**. For instance the closed-loop life cycle in which producers and consumers have a co-dependant relationship and where zero waste is produced in the cycle. This closed loop system can replace the linear and wasteful model commonly employed by human systems and practices (Benyus, 2013).

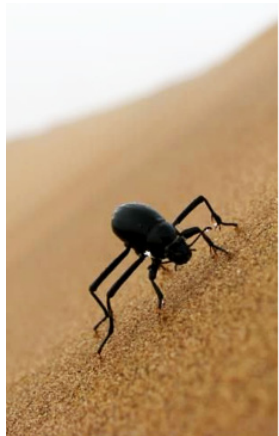

WATER HARVESTING

The Namib beetle has a cleverly designed shell that collects water from early morning dew.



PASSIVE VENTILATION

Termite mounds are constructed with ventilation channels in order to regulate the internal temperatures throughout fluctuation external temperatures.



PASSIVE COOLING

Nature has designed the camel to have a built in cooling system to cool itself down in the desert heat.



SYMBIOSIS

Different organisms in an ecosystem have a symbiotic and mutually beneficial relationship.



CRADLE TO CRADLE

Ecosystems in nature functions in closed loops - where waste is continuously recycled.

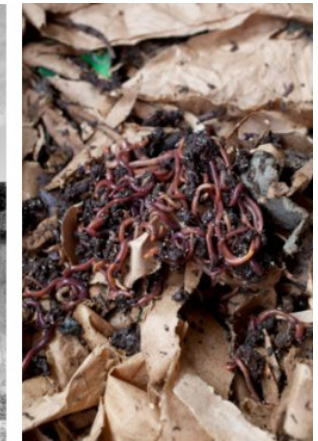

ZERO NET WASTE

There is no such thing as 'waste' in nature - waste produced by one organism is fuel for another.

Figure 2.7. Biomimicry Inspiration: Process - Collage (AskNature, 2016)

Figure 2.8. Biomimicry Inspiration: Systems (AskNature, 2016)

2.2.3 BIOMIMICRY DESIGN SPIRAL

The Biomimicry Design Spiral is a framework that has been formulated to aid designers in their approach when practicing Biomimicry. There are two pathways to the design spiral, the first being Challenge to Biology and the second Biology to Challenge. The Challenge to Biology pathway is used in a scenario where a problem is identified that looks for possible solutions in design found in nature. The Biology to Challenge pathway is when an inspirational process is observed in nature that can be manifested into design to solve a human problem.

For the purpose of this thesis, the Challenge to Biology pathway is selected as the design approach, since a problem/challenge has been identified that will look to nature's genius for possible solutions. The following steps of the Biomimicry Design Spiral are to be taken when approaching a design problem:

DEFINE

Specify your design challenge and its context. What human problem are you trying to solve? What is the nature of the problem?

IDENTIFY

Determine the key function(s) that need to be carried out by the design. What is the purpose of the design? What does it need to do?

INTERPRET

Translate the design problem into Biological terms and define parameters.

DISCOVER

Search for inspiration and biological models in nature that successfully deal with the problem at hand. How does nature do it?

ABSTRACT

Analyse the process/mechanism used by each organism and translate into design principles. What makes the organism so successful at solving the problem at hand?

EMULATE

Develop a design concept using the information gathered and check against Life's Principles.

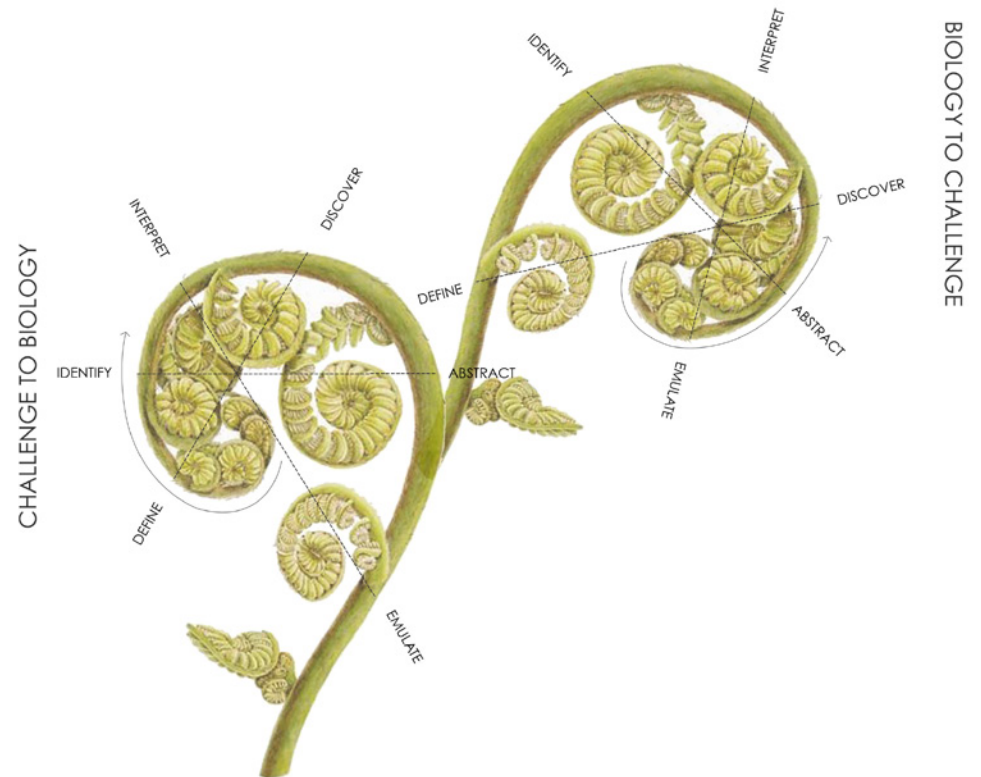

Figure 2.9. Biomimicry Design Spiral (Author, 2016).



Figure 2.10. Botanical imagery of plant life (Etsy, 2007).

2.2.4 LIFE'S PRINCIPLES

Life's Principles represents the survival strategies employed by Mother Nature in order to ensure longevity on planet Earth. These strategies are divided into six groups and are as follows:



Definition: “Invest optimally in strategies that promote both development and growth” (Zanowick, 2012).

Nature recognizes that development and growth need to occur simultaneously for organisms to survive. This is achieved through **combining modular and nested components**. Modularity in nature is seen through repeating patterns that can fit within a larger version of the same pattern – commonly known as fractals. By using these ‘modular building blocks’, nature is able to save energy, resources and time (Zanowick, 2012). Nature also demonstrates the ability to **self-organize**, which refers to the interplay between individual parts coming together to form a much more powerful and efficient system as a whole. Furthermore, nature **builds from the bottom up** in an additive process instead of a subtractive process. In other words, nature builds and constructs organisms one cell at a time and will only disperse material where necessary.

Definition: “Fit into and integrate with the surrounding environment” (Zanowick, 2012).

The conditions of the natural environment are forever evolving, whether it be seasonal changes or changes that occur slowly over years. Organisms in nature have developed the ability to adapt to their immediate surroundings in order to survive (Benyus, 1997). For instance, nature only makes **use of readily available materials and energy** provided within their local environment. The supply of materials and energy may be limited which is why nature has become responsive to such conditions in order to ensure survival. Nature **leverages cyclic processes**, taking advantage of reoccurring cycles on Earth (Zanowick, 2012), for instance animals will foster their young in springtime when food is available in abundance. Additionally, life fosters **cooperative relationships** by creating conditions that encourage symbiotic relationships in which a mutual benefit is shared between two organisms.

Definition: “Appropriately respond to dynamic context” (Zanowick, 2012).

Nature has the ability to adapt to changing conditions in order to survive. Nature **incorporates diversity** of forms, processes and systems to prepare for a better chance at survival. Without diversity, nature would become volatile and vulnerable to environmental threats. Nature **maintains integrity through self-renewal**, a strategy that allows organisms to heal themselves and repair damage. This forms part of an adaptive strategy since organisms are constantly practicing self-renewal and simultaneously adapting to the changing environment (Benyus, 1997). Furthermore, nature **embodies resilience, though variation, redundancy and decentralization** suggesting that a variety of different forms, processes and systems are utilized and are mutually exclusive to prevent the whole ecosystem from collapsing in the event of an unpredicted disturbance.

Figure 2.11. Biomimicry Life's Principles Diagrams (Author, 2016).



Definition: “Skillfully and conservatively take advantage of resources and opportunities”(Zanowick, 2012).

Organisms in nature have developed strategies to use resources such as raw materials and energy efficiently in order to survive. These organisms use minimal resources and produce no waste when performing their necessary functions (Zanowick, 2012). Nature uses **multi-functional design** allowing multiple needs to be met with one solution, sparing resources in the process. Nature builds and constructs organisms using **low energy processes** in order to reduce energy consumption (Benyus, 1997). Nature **recycles all materials** and uses ‘waste’ as a resource to form a closed-loop system. The organic waste produced by one organism is fuel for another. Nature practices being resource efficient by **fitting form to function** (Zanowick, 2012). Patterns and shapes in nature are created based on the functional need. These forms in themselves display resource efficient properties (see Chapter 5).

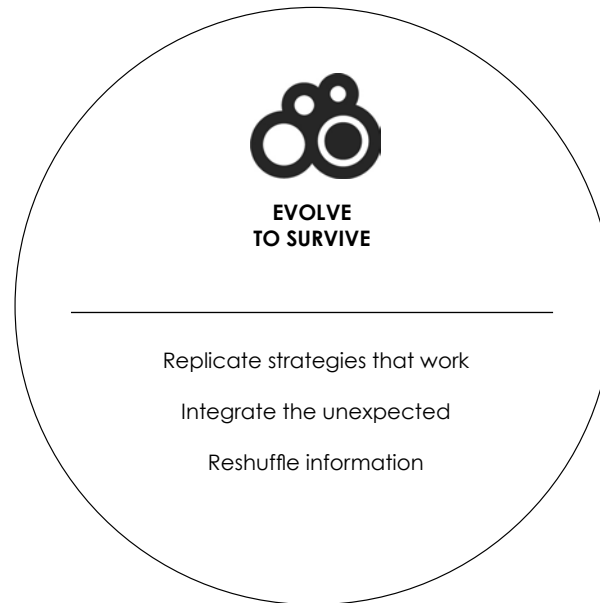

Definition: “Continually incorporate and embody information to ensure enduring performance” (Zanowick, 2012).

Nature is **replicates strategies that work** and is continuously evolving and adapting to environmental conditions in order to survive. Evidence of this includes natural selection and evolution, which proves that only the species capable of adapting to their changing environment will prevail. Nature **integrates the unexpected** in the form of genetic mutations, which might offer a solution to a problem faced by the organism. Nature **reshuffles information** such as genetic material that is combined and reconfigured through reproduction (Zanowick, 2012). This ensures variety, which is essential to survival.

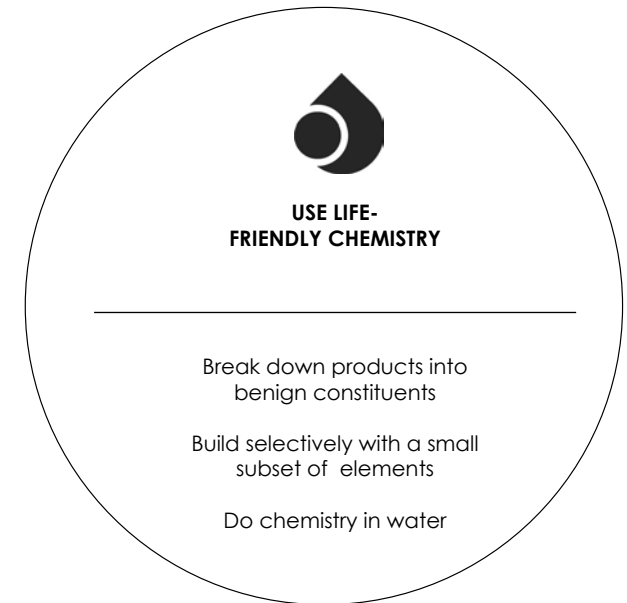

Definition: “Use chemistry that supports life’s processes” (Zanowick, 2012).

The biochemical composition of materials and structures in nature is not harmful to the environment in any way and can be **broken down into benign constituents** that can be recycled back into the ecosystem (Zanowick, 2012). For instance the venom of a snake is only toxic to its prey and once digested by the snake it will be broken down into natural elements that pose no harm to the environment. Nature **builds selectively with a small subset of elements** defined by the periodic table. These are the only elements needed to produce a vast variety of living organisms and structures, and this small subset of elements can be recycled and used over and over again within an ecosystem.



**SKILLFULLY AND CONSERVATIVELY
TAKE ADVANTAGE OF RESOURCES AND
OPPORTUNITIES**

2.2.5 RESOURCE EFFICIENCY IN NATURE

In nature, resources are ‘expensive’ and cannot be used lavishly. Nature has evolved over 3.8 billion years and in the process developed the ability to construct organisms from “*raw materials, procured locally, manufactured at body temperature and pressure*” and at the end of their lifecycle “*these materials are regathered and reconfigured by other organisms, up-cycled again and again with the energy of the sun*” (Benyus, 2013).

So the question is; how can the built environment learn from nature and its processes in order to become more resource efficient?

Life’s Principles - Resource Efficiency

The Biomimicry principles (Biomimicry, 2014); more specifically the principle related to resource efficiency provides a series of strategies that should be followed when dealing with the use and management of natural resources. These strategies include – *USING MULTIFUNCTIONAL DESIGN, USING LOW ENERGY PROCESSES, RECYCLING OF ALL MATERIALS* and *FITTING FORM TO FUNCTION* (see diagram to the left for further details).

USE MULTIFUNCTIONAL DESIGN

Meet multiple needs with one elegant solution.

USE LOW ENERGY PROCESSES

Minimise energy consumption by reducing requisite temperatures, pressures and/or time for reactions.

RECYCLE ALL MATERIALS

Keep all materials in a closed loop.

FIT FORM TO FUNCTION

Select the shape or pattern based on need.

Figure 2.12. Material configuration in Nature: Wood Weave (Flickrriver, 2006).

Figure 2.13. Biomimicry Life’s Principles (Author, 2016) compare with (Biomimicry, 2014).

Minimum Inventory / Maximum Diversity Theory

Theories by Peter Pearce (1978) and D'Arcy Thompson (1961) further elaborate on the strategies employed by nature towards being **resource efficient**.

In his book *Structure in Nature is a Strategy for Design* (1978), Pearce suggests that in order for man to have a synergetic relationship with nature, we need to become **responsive** and **adaptable** to our environments whilst using natural resources conservatively. Pearce (1978: xii) brings forth the concept of MINIMUM INVENTORY/MAXIMUM DIVERSITY systems as the foundation of resource efficiency. This concept boils down to the idea of *using less to create more*, in which **less natural resources** are used to provide an equal or **greater value output**.

Pearce elaborates on this idea and suggests that the concept of minimum inventory/maximum diversity (1978: xii) can be implemented through **standardization of components** that are used as 'a kit of parts'. In other words, a minimum amount of components should allow for a maximum output of '**genetically related structural forms**'. Pearce states;

"When properly used, the principle of component standardization is a system of great production and distribution efficiency. It can also be a system, which conserves natural resources. In a fundamental way, standardization is a principle of modularity. We need to develop a building strategy with which diversity and change can be accomplished by modular systems, which are efficient in their use of natural material and energy resources"

- (Pearce, 1978: xii)

This extract suggests that the use of both **standardization** and **modularity** in the built environment is a strategy that can be employed towards energy and resource efficiency.

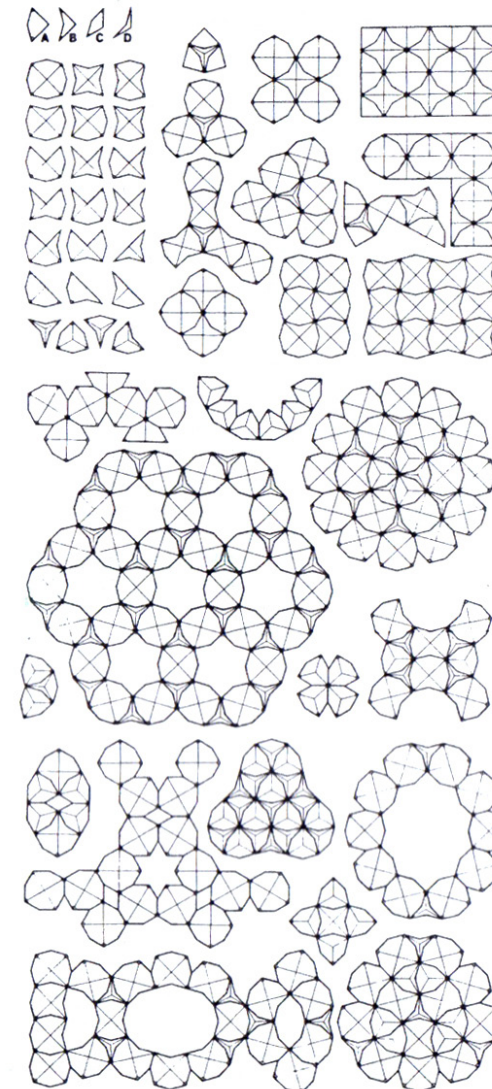

Figure 2.14. Minimum Inventory/Maximum Diversity System (Pearce, 1978: xii).

Intrinsic & Extrinsic Forces in Nature

Both Pearce (1978: xiv) and Thompson (1961: 11) discuss the notion of resource efficient structures and forms found in nature. They convey that these natural forms and structures is a result of minimum-energy processes employed by nature. Thompson (1978: 11) poetically states:

“in short, the form of an object is a diagram of forces; in this sense, at least, that from it we can judge of or deduce the forces that are acting or have acted upon it; in this strict and particular sense, it is a diagram”.

Through this statement, Thompson expresses the way in which forces have the ability to shape and mould forms whilst using minimum energy and resources.

Pearce elaborates on this notion and proposes that form is created as a result of the interplay between intrinsic and extrinsic forces. INTRINSIC FORCES are the internal properties or forces within the structural system that governs its potential performance (Pearce, 1978: xiv). EXTRINSIC FORCES are external to the structural system; often environmental factors, which gives direction to the form (Pearce, 1978: xiv). Figure 2.15 illustrates Pearce’s theory of intrinsic and extrinsic forces and how these forces apply to creation of form and structures in the built environment:

“ FORM AS A DIAGRAM OF FORCES ”

- (a) limitations of resources including energy and materials
- (b) building function including the change of its use over time
- (c) relationship to the community
- (d) emotional ambience

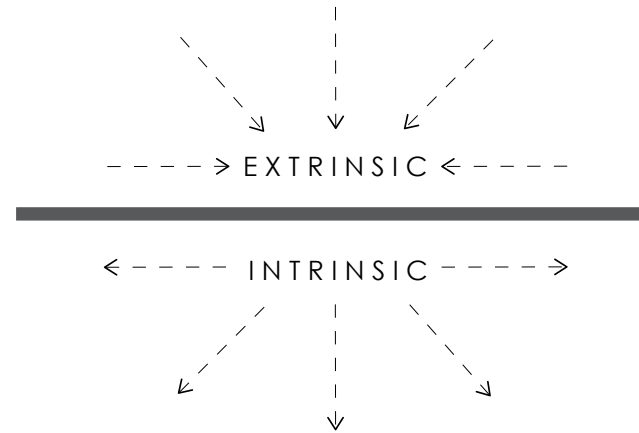

- (a) structural efficiency relative to use of material
- (b) provide diversity of form in order to respond (adapt) optimally to the actions of an array of extrinsic forces
- (c) accommodate change in response to the inevitable long term variations of certain extrinsic forces
- (d) define a minimum inventory of component types in order to simplify and economize the production and use of the system
- (e) take advantage of materials that are consistent with an optimum response to the actions of extrinsic forces and to the economical production of the system’s

Figure 2.15 (Above) Form as a diagram of forces (Author, 2016) compare with (Pearce, 1978: xiv).

Figure 2.16 (Right) Lightweight structures in nature (AskNature,2015)

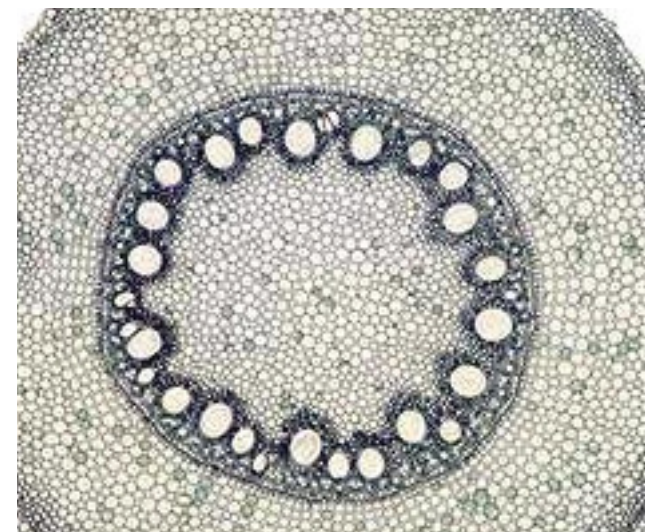
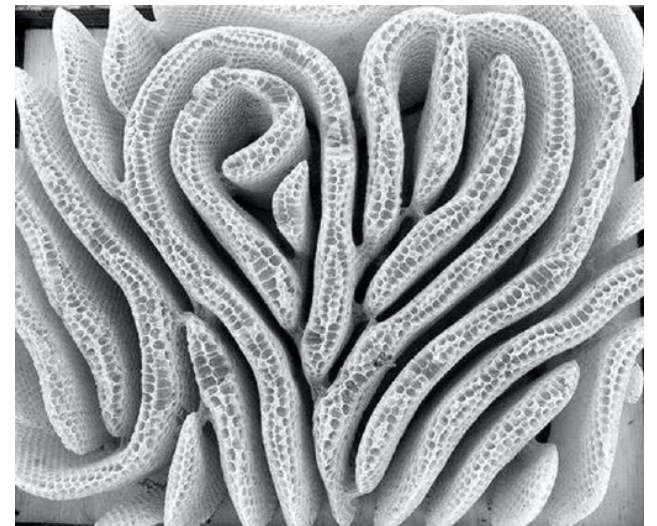
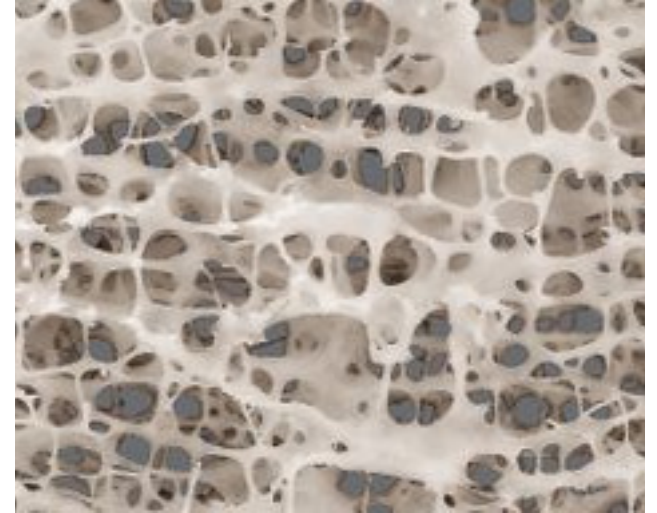

Closest Packing & Triangulation

When looking at the forms and structures in nature, both Pearce (1978: 2) and Thompson (1961: 103) identified the reoccurring hexagonal and triangulation patterns that are a result of the interplay between intrinsic and extrinsic forces governed towards creating resource efficient systems.

Pearce (1978:3) suggests that the occurrence of hexagonal patterns in nature is a result of closest packing. Closest packing is the way in which spherical cells are packed together as tightly as possible. Spherical cells themselves are the most resource efficient form since a sphere is the three-dimensional form that can hold the largest volume with the smallest surface area (Pearce, 1978:4). However, an array of spheres stacked together in a square formation (see Figure 2.17) is not economical and results in a series of empty voids and wasted space between the cells. It is for this reason that spherical cells are stacked in a triangulated formation, which proves to be 7% more economical and allows more spherical cells to be placed in a given area (Pearce, 19878: 3).

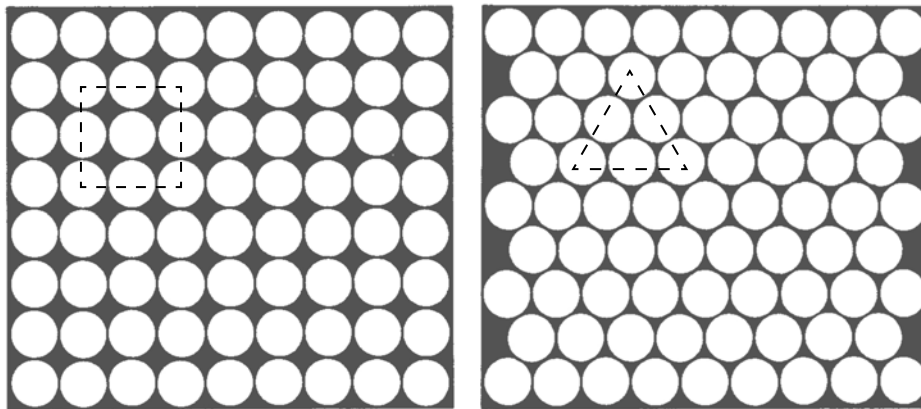

Figure 2.17. Closest Packing in Nature: Triangulation grid connecting cells (Pearce, 1978:3)

Triangulations

The triangulation network created between stacked cells is what gives these structures in nature its inherent stability and robustness. Pearce argues, “The triangle is the only polygon that is stable (rigid) by virtue of its geometry” (Pearce, 1978: 4), which is why these patterns are so prevalent in nature. He suggests that cube geometry does not occur in nature and that we should question its application within the built environment, and create a movement towards implementing triangulated structures. This proposition ties in with the idea of minimum inventory/maximum diversity, which together can be used as a guiding principle towards developing resource efficient structures in the built environment.

CUBE

“There can be no doubt that cube oriented geometry is extremely important and relevant to architectural design; however, it has serious modular limitations with respect to the generation of diversity of form, and as a structural framework it has inferior strength-to-weight properties when compared to triangulated systems... A cursory observation of natural structures shows that cubes rarely occur. This alone suggests that a careful study of other alternatives is advisable.”
(Pearce, 1978: xvii)

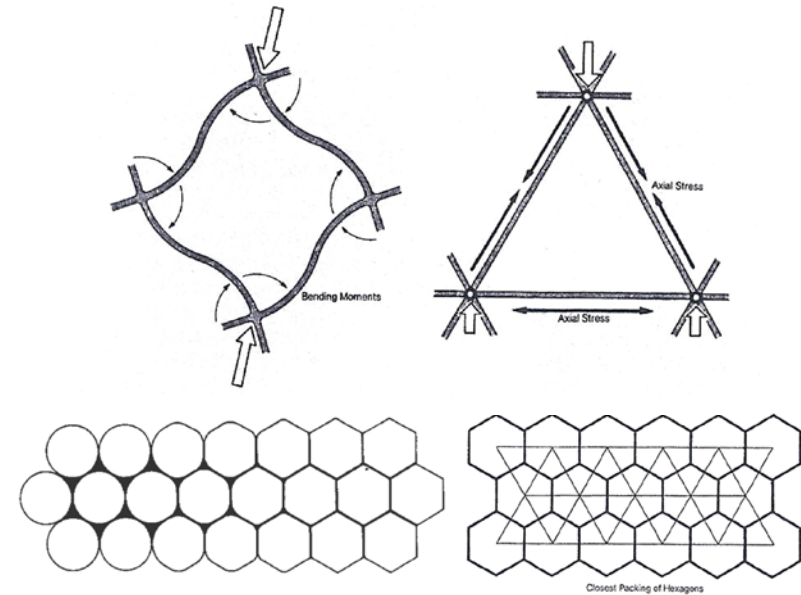
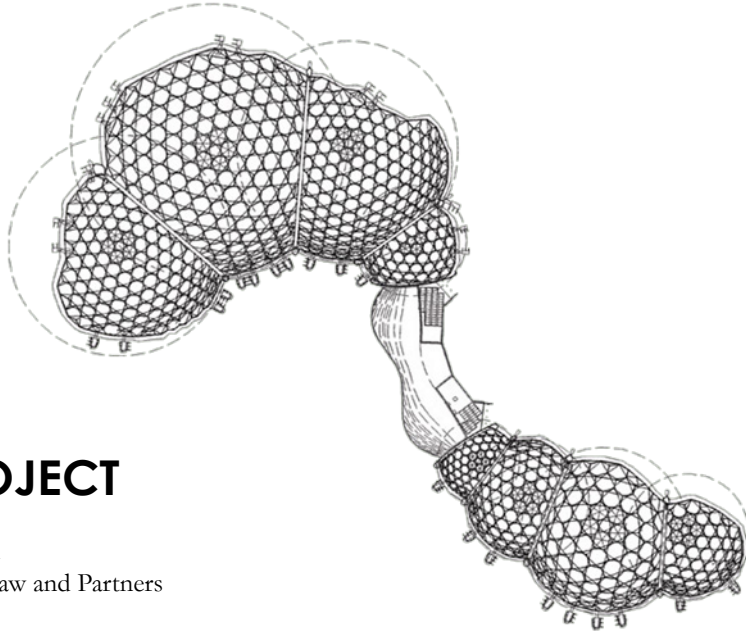

Figure 2.18. Stability of triangular structure (Pearce, 1978: xvii)

TRIANGLE

“It can be readily seen that the principle of closest packing is equivalent to that of triangulation; and it is well known that triangulated frame works exhibit inherent geometric stability. Such properties enable framework structures to be built without moment joints, insuring axially loaded members; and this in turn results in high strength-per-weight minimum energy structures”
(Pearce, 1978: xiv)



EDEN PROJECT

Cornwall, UK
Architectural Design
By Nicholas Grimshaw and Partners
2001

2.2.6 BIOMIMICRY PRECEDENT STUDIES

The Eden Project is a series of biomes set in place to not only conserve over five thousand different species of plants from various climatic zones across the world, but to also educate and provide an enjoyable experience for the public who wish to visit the space. One of the main aspirations that the Eden Project hopes to achieve is to “promote the understanding and responsible management of the vital relationship between plants, people, and resources, leading towards a sustainable future for all” (Perrin, 2007).

A series of design criteria were to be met in the creation of the Eden Project. Firstly, an enclosure had to be designed to span over great distances without the need for internal support structures. Secondly, it was important for the structure to be rendered lightweight in order to cut carbon emissions produced in the transportation process since most of the raw materials were not retrieved locally. The structure being lightweight would also eliminate the need for extensive foundations that would have otherwise caused potential damage to the soil conditions (Bissegger, 2006).

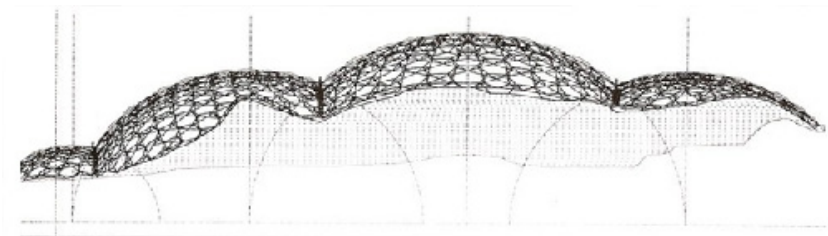

Figure 2.19 Eden Project (Perrin, 2007)



Figure 2.20. Photos of Eden Project (Perrin, 2007).

BIOMIMICRY PAVILION

Architectural Concept Design

By Andres Harris

Andres Harris' proposed pavilion design is a brilliant example of the application of Biomimicry in the field of architecture. Harris aspired to design a structure that would be strong and durable and that would be constructed using material in the most efficient way possible so as to render it lightweight (Harris, n.d).

Bone tissue, especially that of bird skulls was used as the source of inspiration for this project. Bird skulls are an interesting study. The skull has to be strong enough to protect the organs of a bird, yet remain lightweight enough to allow the bird to take flight with ease. The structural system of a bird skull achieves this through providing a higher density of bone tissue in areas that undergo higher external pressures, and little or no bone tissue in areas that are not greatly subjected to external pressures. Air pockets fill the voids between the bone tissues, reducing the overall weight of the structure without affecting its strength (Harris, n.d).

The image below shows Andres Harris's pavilion design. It consists of two leafs of solid material that is held together with vertically elongated supporting structures. These vertical members create air pockets between the upper and lower solid leafs giving it greater strength with 'lightweight' properties – much like that of a bird skull.

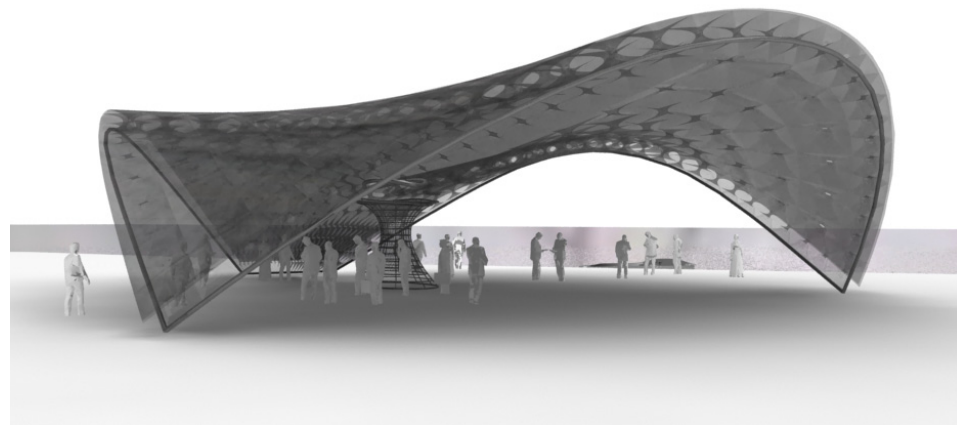
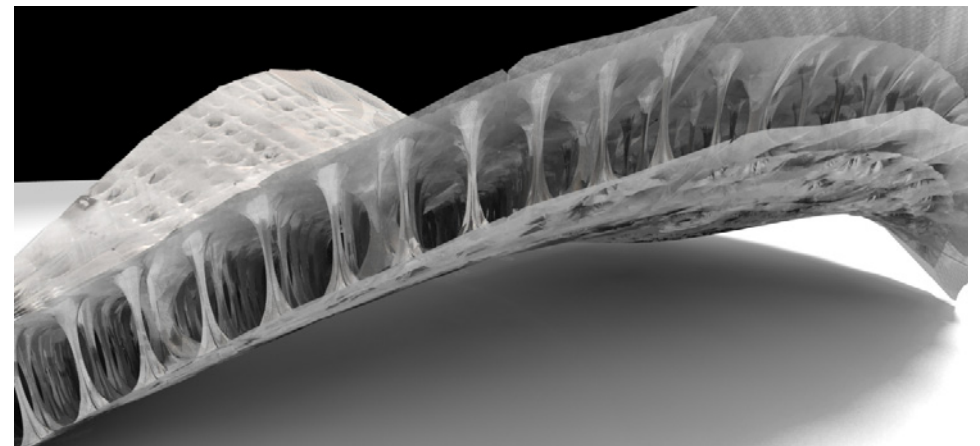

Figure 2.21 Biomimicry Pavilion Design by Andres Harris (Harris, n.d.)



3D PRINTED CHAIR

Industrial Design
By Lilian van Daal
2014

Dutch industrial designer, Lilian van Daal, recognized the resource-intensive and wasteful production process of traditional upholstered furniture and aimed to explore alternative methods of production to create streamline and resource-efficient furniture pieces. She used biomimicry as a design tool and looked to nature for inspiration on how to tackle this problem (Hogan, 2013).

Van Daal looked at the cell structure of plants to understand how nature distributes material to create strong and durable yet lightweight and resource efficient structures. She then emulated the processes observed in nature and applied it in her design to create a 3D printed chair that resembles the cell structure of a plant. Using 3D printing technology, van Daal was able to test the flexibility and stiffness of various materials to identify their individual structural properties. Van Daal wanted to challenge the resource-intensive nature of traditional furniture production methods by producing a furniture piece using one material alone. Nylon was the chosen material for the first prototype of her chair; however van Daal is working on using a biological material instead for the chair to be more sustainable (Hogan, 2013).

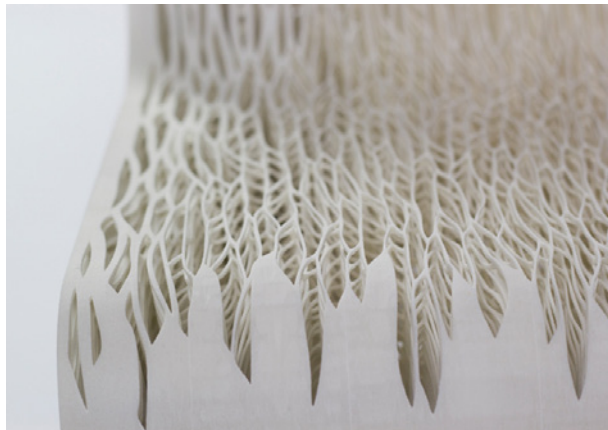

Figure 2.22. 3D Printed Chair by Lilian Van Daal (Hogan, 2013).



2.2.7 WASTE AS A RESOURCE IN NATURE

Nature exemplifies a ‘cradle-to-cradle’ model, in which ‘waste’ is seen as a valuable resource (McDonough & Braungart, 2002). By studying the cradle-to-cradle model we can learn from nature’s approach to recycling waste, in the aim of applying these practices in a retail design scenario.

Theories regarding Cradle-to-Cradle Design

William McDonough and Michael Braungart (2002) are leaders of the cradle-to-cradle design model. They proposed the concept of ‘houses like trees’ and ‘cities like forests’ – and refer to the metaphor of the ‘cherry tree’;

“As it [the cherry tree] grows, it seeks its own regenerative abundance. But this process is not single-purpose. In fact, the tree’s growth sets in motion a number of positive effects. It provides food for animals, insects and microorganisms. It enriches the ecosystem, sequestering carbon, producing oxygen, cleaning air and water, and creating and stabilizing soil. Among its roots and branches and on its leaves, it harbors a diverse array of flora and fauna, all of which depend on it and on one another for the functions and flows that support life. And when the tree dies, it returns to the soil, releasing, as it decomposes, minerals that will fuel healthy new growth in the same place.”

Through this metaphor, McDonough and Braungart suggest that buildings and cities should operate like an ecosystem; in which buildings are seen as nutrient dense structures that have the ability to give back to its surrounding environment, and also for these buildings to form part of a greater whole that sustains not only itself but a greater community.

Three Defining Principles of Cradle-to-Cradle Design

McDonough and Braungart proposed that there are three essential principles to the Cradle-to-Cradle model, which are as follows:

- (A) WASTE EQUALS FOOD
> Everything is a nutrient for something else
- (B) USE CURRENT SOLAR INCOME
> Energy that can be renewed as it is used.
- (C) CELEBRATE DIVERSITY
> Species, cultural and innovation diversity.

Figure 2.23. Waste Equals Food: Growth of fungi (StudioChoo, 2010)

(A) WASTE EQUALS FOOD

The **Waste Equals Food** principle is undoubtedly a trademark of the Cradle-to-Cradle model, and represents the ‘closed-loop’ cycle of materials, water and energy – where all materials are recycled and nothing is wasted (McDonough & Braungart, 2002).

As inspired by ecosystems in nature; McDonough and Braungart (2002) created a closed loop material recycling model that emulates nature's systems and processes. These closed loop models are defined as the **Biological Metabolism** and the **Technical Metabolism** (see Figure 2.24).

The **BIOLOGICAL METABOLISM** is the process of recycling biological nutrients; characterized by biodegradable materials that are not harmful to the environment after human use and can be returned to nature for biological processes. Both natural and synthetic materials can be classified as biological nutrients, as long as they are safe for human and environmental systems.

The **TECHNICAL METABOLISM** is the process of recycling technical nutrients, which are classified as materials such as polymers and minerals that can be safely (re) used within an industrial cycle; but are never returned back to the natural environment for biological processing. It is important for technical nutrients to maintain their quality and value through the continuous cycles of production, recovery and reuse to avoid ‘down cycling’ of materials, which would eventually end up as waste materials in a landfill.

(B) USE OF CURRENT SOLAR INCOME

Nature taps into the abundant supply of energy from the sun to carry out all biological processes. McDonough and Braungart (2002) promote the use of this renewable source of solar energy for human needs within the built environment including electricity, heating and lighting.

(C) CELEBRATE DIVERSITY

Nature is one large ecosystem that supports an abundant array of different organisms that coexist and often foster interdependent relationships. We as human beings on the other hand, only look out for ourselves and destroy habitats of other living organisms in our natural environment through processes such as mining and deforestation.

The third principle of the Cradle-to-Cradle model; Celebrate Diversity, therefore aims to guide human processes towards an ecosystemic model as seen in nature, that allows a complex network of living organisms not only to co-exist but to work together to build a healthier and sustainable living environment that is conducive to life. This principle encourages both bio-diversity and diversity of form in the built environment, which leads to innovative design that allows for adaptation to local conditions.

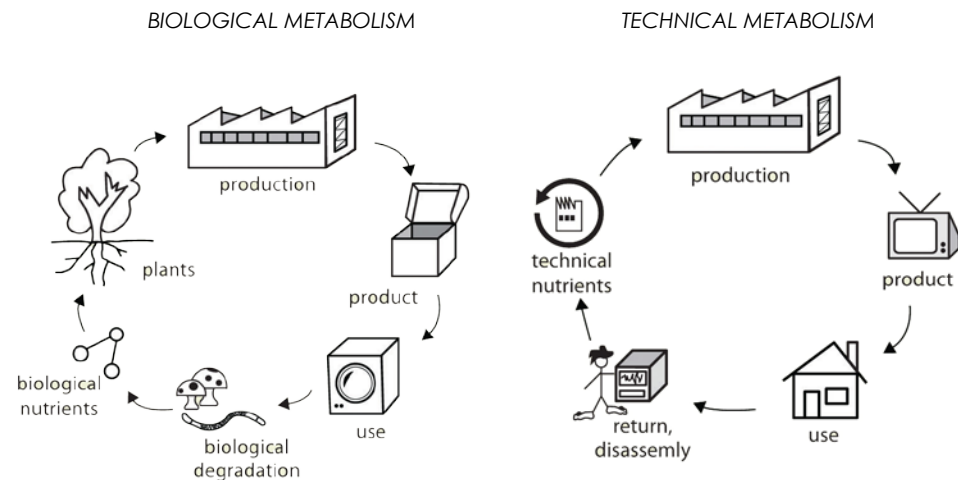

Figure 2.24 Biological and Technical Metabolism (McDonough & Braungart, 2002)

"A cradle to cradle building contains elements that add value and celebrate innovation and enjoyment by: measurably enhancing the quality of materials, biodiversity, air, and water; using current solar income; being deconstructable and recyclable, and performing diverse practical and life-enhancing functions for its stakeholders"

- McDonough & Braungart, 2002

2.2.8 BIOMIMICRY PRECEDENT STUDIES

Closed-Loop Coffee Farm

A closed-loop coffee farm system was developed by ZERI (Zero Emissions Research and Initiatives) that reuses waste as a resource. This ecosystemic approach to agriculture was inspired by Biomimicry's Life Principles and emulates the concept of closed-loop systems (AskNature, 2015). ZERI recognized that the making of coffee from raw coffee beans only has a 0.2% yield, which leaves 99.8% waste as a by-product. In order to prevent this waste from ending up in a landfill or in rivers, ZERI aimed to devise a closed-loop scheme for the farmers in which the waste would be recycled back into their coffee production systems (AskNature, 2015).

The success of the system lied in discovering that Shiitake mushrooms thrive in bio-waste – such as the waste produced in the coffee making process. The closed-loop system therefore involves growing of Shiitake mushrooms in the coffee bio waste, which is then sold to the local market (Ask Nature, 2015). Furthermore, cattle and pigs are fed with the organic residue left over after harvesting of the coffee beans. The manure from the farm animals is then fed into a bio-digester that produces heat for the mushroom farming, and organic fertiliser that is used for growing the coffee plants (AskNature, 2015).

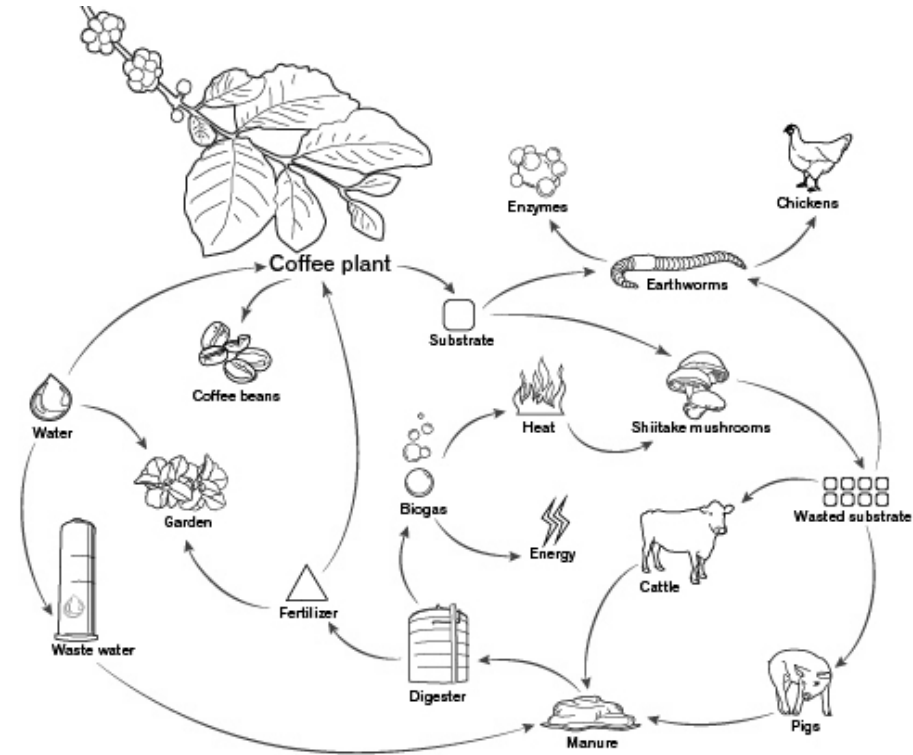

Figure 2.25. Closed-Loop Coffee Farm (AskNature, 2015).

Cardboard to Caviar Closed-loop System

The Cardboard to Caviar model; developed by Graham Wiles, mimics closed-loop systems found in nature with the aim of using waste as a resource (Bradley, 2016). Wiles recognized an opportunity to use the cardboard boxes discarded as waste in a caviar restaurant business and turn it into a resource that at the end of the cycle aids cultivation of caviar – hence forming a closed-loop cycle.

The operations of the Cardboard to Caviar closed-loop model is as follows:

1. Mr. Wiles collects cardboard boxes from the caviar restaurant.
2. These cardboard boxes are shredded and sold to a stable for horse bedding
3. Mr. Wiles collects and removes the spent horse bedding from the stables.
4. Mr. Wiles then uses the spent horse bedding as feed for the worms that he farms.
5. The worms are used as feed for Sturgeon, which produce caviar.
6. Mr. Wiles then sells the caviar to the restaurant and also collects their cardboard boxes, repeating the cycle.

(Bradley, 2016) CO²

The Cardboard to Caviar model is another great example of how we can learn from nature to use waste as a resource.

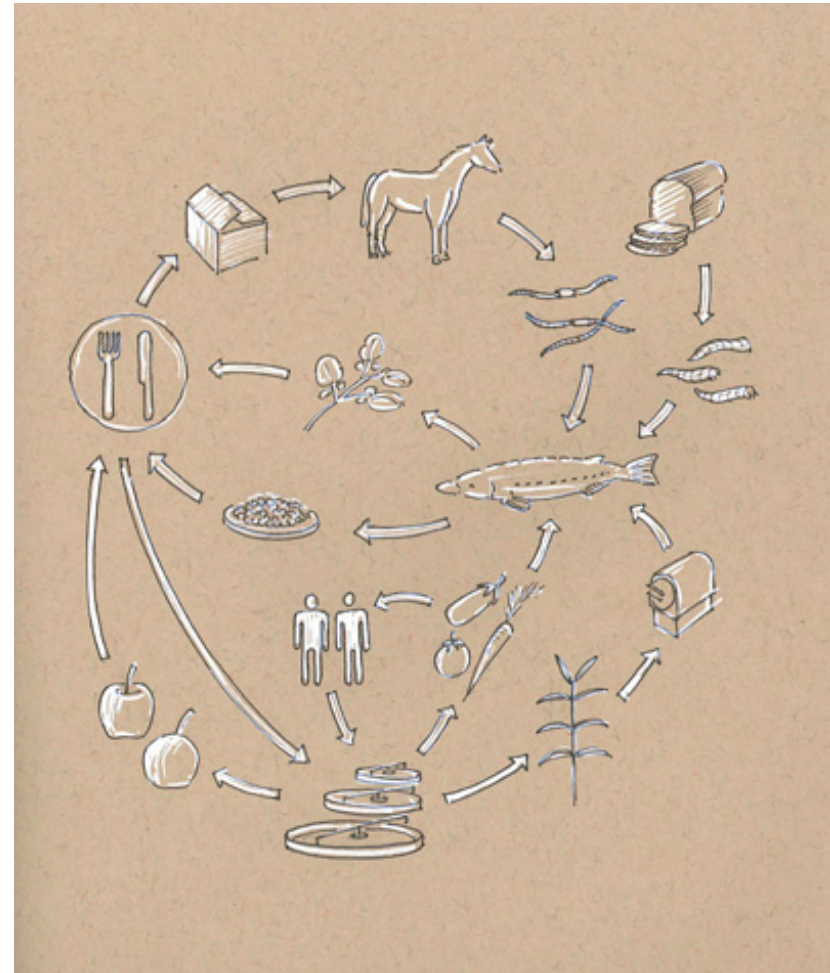

Figure 2.26. Cardboard to Caviar Closed-Loop System (Bradley, 2016)

2.3 EXPERIENTIAL & BIOPHILIA DESIGN THEORY

Looking at human cognitive and behavioural responses is important for the purpose of this study, as it will provide insight to the psychology and scientific facts behind the reason why we feel and behave a certain way in a given environment. Such research can be used to manipulate the users experience of a spatial environment, and in this case, a brick-and-mortar retail environment.

The following theories explore the relationship between the environment and its inhabitants. By nature, many of the theorists involved in such studies have varying opinions on the environmental factors that most significantly contribute to certain cognitive and behavioural responses. For this reason, it was decided to investigate a variety of theories to gain a broad understanding of the topic at hand.

2.3.1 ATMOSPHERICS

The term atmospherics was coined by Kotler (1974: 50) to describe the “conscious designing of space to create certain effects in buyers”. The literal meaning of the word “atmosphere” translates into the air surrounding a sphere. The word atmosphere is often casually used to describe the quality and feel of ones surroundings. Kopec believes that the incorporation of atmospherics in the design of retail space can contribute to an enhanced environmental experience (Kopec 2006: 301).

According to Kotler (1974: 51), atmosphere is perceived as a sensory experience of a space including sight, sound, touch and scent. Taste is also a sensory experience but is excluded within Kotler’s theory of atmospherics since an atmosphere cannot be tasted (Kotler, 1974: 51). Kotler further breaks down these four sensory channels into sub- dimensions. The visual sub-dimensions of an atmosphere include colour, brightness, size and shapes. The aural sub-dimensions of an atmosphere include volume and pitch. The olfactory sub-dimensions of an atmosphere include scent and freshness. And lastly, the tactile sub-dimensions of an atmosphere include softness, smoothness and temperature (Kotler, 1974: 51). These sub-dimensions can be used to describe the atmosphere of a particular environment. For example, the atmosphere of a spa is subdued, quiet, invigorating and soft whilst a recreational park on the other hand is bright, noisy, loud and rough (Kotler, 1974: 51).

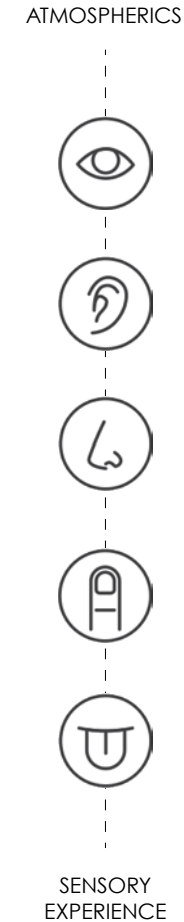

Figure 2.27 Atmospherics and sensory experience diagram (Author, 2016).

Kotler further explains that differentiation must be made between intended atmosphere and perceived atmosphere (Kotler, 1974: 53). Designers may intend to induce a certain atmosphere in any given setting such as a restaurant through manipulating colour, brightness, sound and temperature for instance. However it is not a given that the intended atmosphere of the space will translate into the users perceived atmosphere since our perceptions is partly a learned experience and will differ from person to person (Kotler, 1974: 53).

Furthermore, Kotler (1974:48) proposes the notion that atmospherics can be used as a means to design a retail space to provide added value - *“One of the most significant features of the total product is the place where it is bought and consumed. In some cases, the place, more specifically the atmosphere of a place, is more influential than the product itself in the purchase decision”*. Through this notion, Kotler argues that there may be a misperception in the consumer industry in thinking that the product or service is the main element of attraction, when in actual fact it is the spatial environment or the ‘brick-and-mortar’ as he refers to it, that has the greatest influence on the consumer’s decision making process (1974: 48). Kotler touches on the concept of Gestalt psychology, which states - *“the whole is greater than the sum of its parts”* (Humphrey, 1924). Kotler suggests that buyers respond to a total product; which is comprised of the product/service, packaging, images, advertising and the in-store environment as a collective whole (Kotler, 1974: 63). Kotler believes that the place/in-store environment where the product or service is purchased is the most significant feature of the total product.

“Total design is the philosophy of creating a unified decor and tone throughout a building”

Kotler (1974: 63)

Why is atmospherics important?

Atmospherics can be used as a marketing tool and is most effective under certain circumstances (Kotler, 1974: 53). Kotler makes the following 5 propositions of circumstances in which the use of atmospherics as a marketing tool would be most effective.

_ Atmospherics is a relevant marketing tool mainly in situations (a) where the product is purchased or consumed; and (b) where the seller has design options.

Ultimately, this implies that atmospherics is a useful tool for retailers but not wholesalers, and that consumers purchasing from retailers will have greater control over where they buy, and as previously mentioned, place (atmosphere) contributes greatly to the total product.

_ Atmospherics becomes a more relevant marketing tool as the number of competitive outlets increase.

Atmospherics has the ability to distinguish one merchant over another competing in the same sector. It has the ability to attract and hold a specific segment of the market and ensures customer returns and loyalty.

_ Atmospherics is a more relevant marketing tool in industries where product and/or price differences are small.

Merchants competing in the same market sector usually use price and product to distinguish themselves from their competition. Atmospherics can be used as a marketing tool that will set one merchant above another in the event of competitors providing similar products and price ranges.

_ Atmospherics is more relevant as a marketing tool when product entries are aimed at distinct social classes or life style buyer groups.

Atmosphere can provide consumers clues to the particular market segment of the store. For example, a high-class retailer would display fewer products than a low class retailer to brand its products as exclusive and one of a kind.

2.3.2 EXPERIENTIAL DESIGN TOOLS

In her article *Come to Your Senses* (2008: 36), Catherine Warren Leone elaborates on the power of the five senses within sensory design. According to Leone, “*emotions form the basis of thoughts*”, which is fueled by the five senses – **sight, touch, sound, smell** and **taste** (2008: 36). Leone elaborates on the topic of emotions by quoting Dan Hill, author of *Emotionomics: Winning Hearts and Minds* (Adam Business & Professionals) – “*Emotions affect awareness, consideration, persuasion, recall and loyalty in the marketplace*”. Therefore it is understood that sensory design affects consumers’ emotional response to an environment, which affects perceptions of corporate brand identity.

2.3.3 BIOPHILIC SENSORY EXPERIENCE

Biophilic design incorporates nature into the built environment in order to provide occupants with the physiological and psychological benefits gained from exposure to nature (Browning, 2014). Biophilic design differs from Biomimicry, in the sense that Biomimicry is a design tool that encourages mimicking of natural forms, processes and systems in order to solve sustainability issues in the built environment (Benyus, 1997), whereas Biophilic design focuses on mimicking the experiential qualities of nature. The use of Biophilic design in the built environment is geared towards healing and rejuvenation of occupants through reducing stress, improving cognitive function and uplifting moods (Browning, 2014). For the purpose of this study, the Biophilic design patterns will be analysed and subdivided into the five sensory categories, namely visual stimuli, audio stimuli, olfactory stimuli, tactile stimuli, and gustatory stimuli; in order to understand how these patterns in nature can be used to influence an in-store sensory experience.

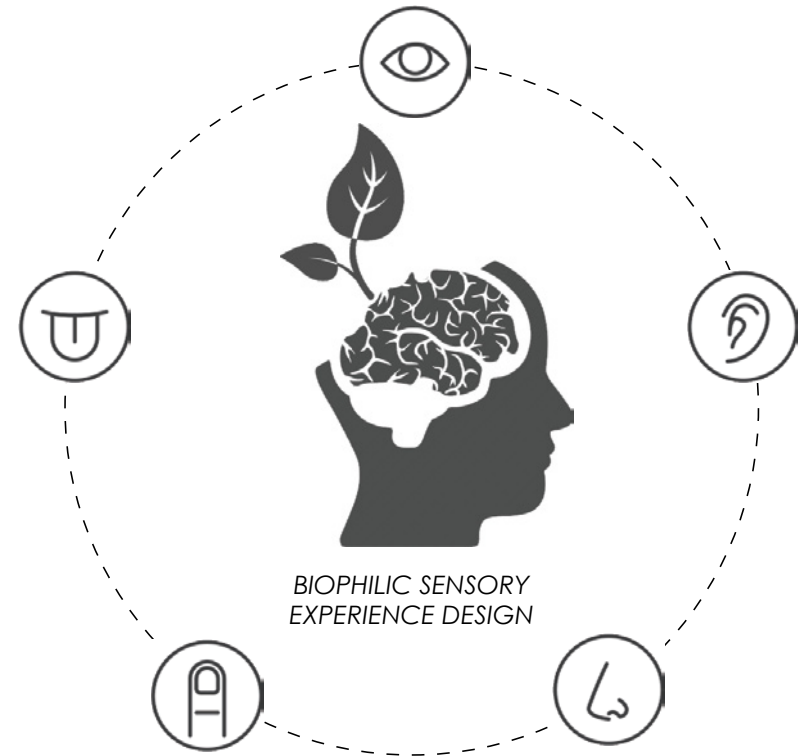

"...the enjoyment of scenery employs the mind without fatigue and yet exercises it, tranquilizes it and yet enlivens it; and thus, through the influence of the mind over the body, gives the effect of refreshing rest and reinvigoration to the whole system."

Browning, 2014

Figure 2.28. Sensory Experience Diagram (Author, 2016).

Biophilic Design Patterns

There are fourteen patterns of Biophilic design that are subdivided into three groups, including Nature in the Space, Natural Analogues and Nature of the Space (Browning, 2014), which are explained in the table below:











NATURE IN THE SPACE Ephemeral Presence of Nature in a Space	NATURAL ANALOGUES Organic, Non-living & Indirect Evocations of Naturee.g. objects, materials, colours, shapes, sequences, patterns	NATURE OF THE SPACE Spatial Configurations in Nature
 <p>[P1] <i>VISUAL CONNECTION WITH NATURE</i> A view with elements of nature, living systems and natural processes.</p>	 <p>[P8] <i>BIOMORPHIC FORMS & PATTERNS</i> Symbolic references to contoured, patterned, textured or numerical arrangements that persist in nature.</p>	<p>[P11] <i>PROSPECT</i> An unimpeded view over a distance for surveillance and planning.</p>
    <p>[P2] <i>NON-VISUAL CONNECTION WITH NATURE</i> Auditory, haptic, olfactory or gustatory stimuli that engender a deliberate and positive reference to nature, living systems or natural processes.</p>	 <p>[P9] <i>MATERIAL CONNECTION WITH NATURE</i> Material and elements from nature that, through minimal processing, reflect the local ecology or geology to create a distinct sense of place.</p>	<p>[P12] <i>REFUGE</i> A place for withdrawal, from environmental conditions or the main flow of activity, in which the individual is protected from behind and overhead.</p>
<p>[P3] <i>NON-RHYTHMIC SENSORY STIMULI</i> Stochastic and ephemeral connections with nature that may be analyzed statistically but may not be predicted precisely.</p>	 <p>[P10] <i>COMPLEXITY & ORDER</i> Rich sensory information that adheres to a spatial hierarchy similar to those encountered in nature.</p>	<p>[P13] <i>MYSTERY</i> The promise of more information achieved through partially obscured views or other sensory devices that entice the individual to travel deeper into the environment</p>
 <p>[P4] <i>THERMAL & AIRFLOW VARIABILITY</i> Subtle changes in air temperature, relative humidity, airflow across the skin, and surface temperatures that mimic natural environments.</p>		<p>[P14] <i>RISK/PERIL</i> An identifiable threat coupled with a reliable safeguard.</p>
<p>[P5] <i>PRESENCE OF WATER</i> A condition that enhances the experience of a place through the seeing, hearing or touching of water.</p>		
 <p>[P6] <i>DYNAMIC & DIFFUSE LIGHT</i> Leveraging varying intensities of light and shadow that change over time to create conditions that occur in nature.</p>		
<p>[P7] <i>CONNECTION WITH NATURAL SYSTEMS</i> Awareness of natural processes, especially seasonal and temporal changes characteristic of a healthy ecosystem.</p>		

Table 2.3 Biophilic Design Patterns (Author, 2016) compare with (Browning, 2014).

Psychological and Physiological Influences of Nature

Biophilic design is geared towards understanding how nature in the built environment can improve human cognitive, psychological and physiological well-being, often referred to as a mind-body system (Browning, 2014).

Cognitive functionality and performance encompasses the mental aspects of well-being such as memory, ability to learn, to make logical decisions and creativity. Performing cognitive tasks can be mentally draining and energy intensive resulting in mental fatigue (Kellert et al., 2008; van den Berg et al., 2007). Research shows that a connection with nature combats mental fatigue and restores mental cognitive performance (Browning, 2014).

Psychological well-being mainly deals with human emotions and moods, but also includes alertness, concentration and stress management. Various studies (Alock et al., 2013; Barton & Pretty, 2010; Hartig et al., 2003) prove that a connection with nature in the built environment supports reduction of stress, anxiety, confusion and fatigue and has a positive effect of moods and emotions.

Physiological well-being refers to a person's overall physical comfort and encompasses the functionality and performance of musculoskeletal and respiratory systems as well as human circadian rhythms which impacts sleeping patterns (Browning, 2014). According to Park et al. (2009), exposure to nature has to ability to lower blood pressure and heart rate, and also helps relaxation of muscles.

	14 PATTERNS	STRESS REDUCTION	COGNITIVE PERFORMANCE	EMOTION, MOOD & PREFERENCE
NATURE IN THE SPACE	VISUAL CONNECTION WITH NATURE	Lowered blood pressure and heart rate	Improved mental engagement/ attentativeness	Positively impacts attitude and overall happiness
	NON-VISUAL CONNECTION WITH NATURE	Reduced systolic blood pressure and stress hormones	Positive impact on cognitive performance	Improves mental health and tranquility
	NON-RHYTHMIC SENSORY STIMULI	Positive impact on heart rate, systolic blood pressure and sympathetic nervous system activity	Quantified behavioural measures of attention and exploration	x
	THERMAL & AIRFLOW VARIABILITY	Positive impact on comfort, well-being and productivity	Positive impact on concentration	Improves perception of temporal and spatial pleasure
	PRESENCE OF WATER	Reduced stress, increased feelings of tranquility, lower heart rate and blood pressure	Improves concentration and memory resotation Enhances perception and psychological responsiveness	Positive emotional responses
	DYNAMIC & DIFFUSE LIGHT	Positive impact on circadian system and visual comfort	x	x
	CONNECTION WITH NATURAL SYSTEMS	x	x	Enhances positive health responses and shifts perception of environment
NATURAL ANALOG	BIOMORPHIC FORMS & PATTERNS	x	x	Positive view preferences
	MATERIAL CONNECTION WITH NATURE	x	Decreases diastolic blood pressure Improves creative performance	Improves comfort
	COMPLEXITY & ORDER	Positive impact on perceptual and physiological stress response	x	Positive view preferences
NATURE OF THE SPACE	PROSPECT	Reduced stress	Reduces boredom, irritation and fatigue	Improves comfort and perceived safety
	REFUGE	x	Improves concentration, attention and perception of safety	x
	MYSTERY	x	x	Induces strong pleasure response
	RISK/PERIL	x	x	Strong dopamine and pleasure responses

Table 2.3. Psychological influences of nature (Author, 2016) compare with (Browning, 2014).

 **Visual Stimuli**

Sight is our most dominant sense and therefore plays the largest role in the way we perceive a space. There are four patterns in nature that are attributed to visual stimuli; these patterns include [P1] VISUAL CONNECTION WITH NATURE, [P6] DYNAMIC & DIFFUSE LIGHT, [P8] BIOMORPHIC FORMS AND PATTERNS and [P10] COMPLEXITY AND ORDER. Each of these patterns and their influence on the experiential qualities within the built environment will be explored in greater detail.



THE EXPERIENCE

[P1] VISUAL CONNECTION WITH NATURE

A space with a good Visual Connection with Nature feels whole, it grabs one's attention and can be stimulating or calming. It can convey a sense of time, weather and other living things.

[P6] DYNAMIC & DIFFUSE LIGHT

A space with a good Dynamic & Diffuse Light condition conveys expressions of time and movement to evoke feelings of drama and intrigue, buffered with a sense of calm.

[P8] BIOMORPHIC FORMS & PATTERNS

A space with good Biomorphic Forms & Patterns feels interesting and comfortable, possibly captivating, contemplative or even absorptive.

[P10] COMPLEXITY & ORDER

A space with good Complexity & Order feels engaging, and information-rich, as an intriguing balance between boring and overwhelming.



Figure 2.29. Visual Sensory Experience (Browning, 2014; Pixel, 2013).

[P1] VISUAL CONNECTION WITH NATURE

Various studies on the Visual Connection with Nature prove that views of nature has the ability to reduce stress, improve concentration and mental engagement, and have a positive influence on a person's mood (Barton & Pretty, 2010). The intention behind introducing a visual connection with nature in the built environment is to relax the occupants and to reduce cognitive fatigue (Browning, 2014).

[P6] DYNAMIC & DIFFUSE LIGHT

According to Mead (2001, 78) light plays a vital role in the perceived atmosphere and experience of a space. It is a highly complex visual element that contributes to the creation of perceptual clarity, spaciousness, relaxation and tension, public versus private space, spatial complexity and pleasantness within a space.

Daylight is the most natural form of lighting and has shown to have physiological and psychological affects on the human body (Browning, 2014). The dynamic and fluctuating colour of daylight from the yellow morning light, the blue midday light and red afternoon/evening light influences human circadian rhythms, body temperature and heart rate (Kendal et al, 2013). It has also been proven that daylight positively influences a person's mood and well-being (Nicklas & Bailey, 1996).

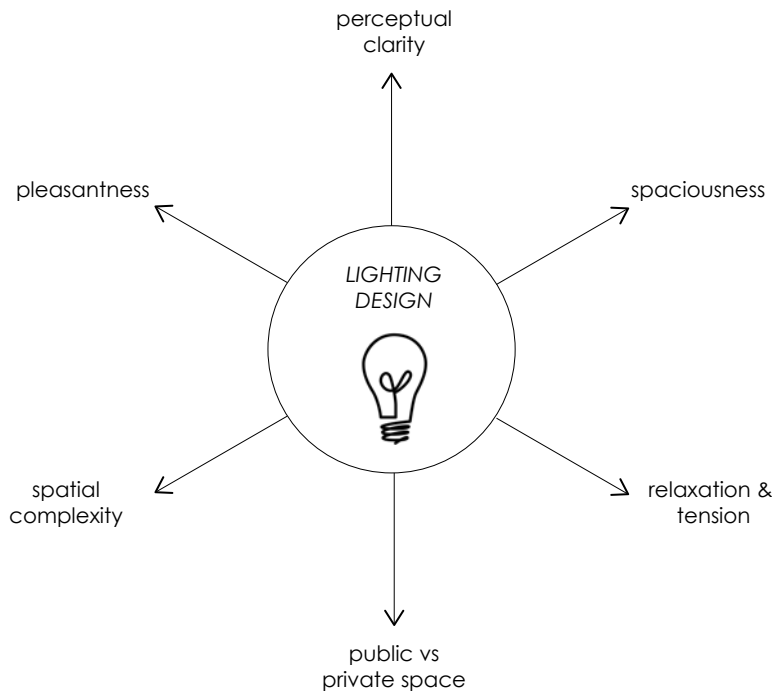

Figure 2.30. Lighting design influences on atmospheric qualities (Author, 2016).

Browning (2014) suggests that introducing dynamic and diffused lighting in the built environment, that mimics the fluctuating patterns of daylight can serve the purpose of capturing the attention of occupants, as well as posing a positive influence on their physiological and psychological well-being. The idea is to introduce layers of diffused, accent and task lighting that creates a visually stimulating and pleasing environment (Clanton, 2014).

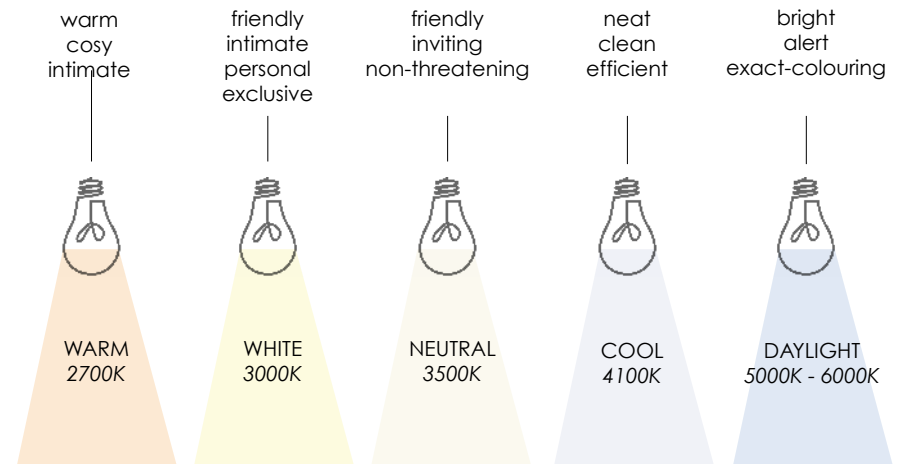

Figure 2.42. Correlated Colour Temperature & Associative Meanings (Author, 2016).

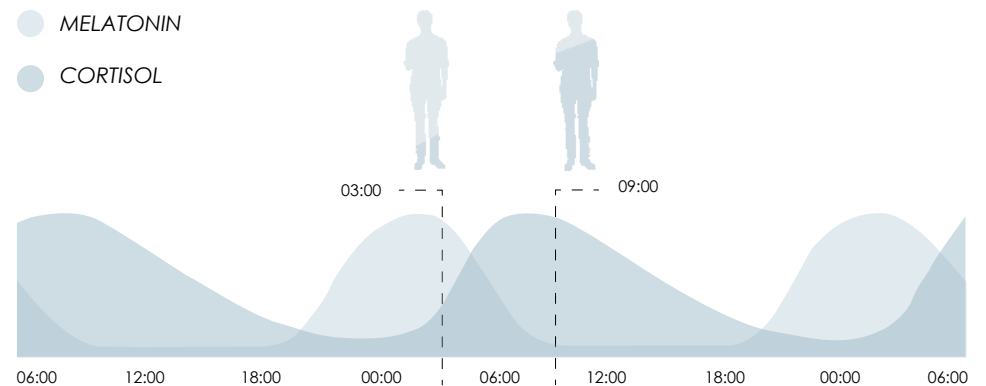

Figure 2.41. Daylight physiological influences (Author, 2016) compare with (Gombikova, 2014).

[P8] BIOMORPHIC FORMS AND PATTERNS

Form possesses a visual grammar and plays a big role in the way we visually perceive a space. In design, form and shape has the ability to organize information, symbolize different ideas, create movement, texture and depth, convey moods and emotions, emphasize points of interest and leads the eye from one point to another (Bradley, 2010).

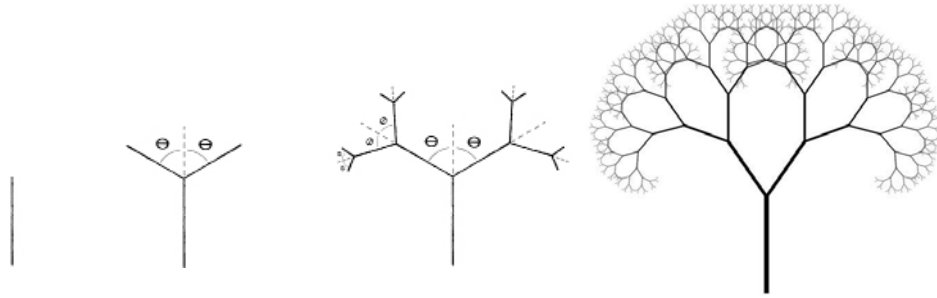

Figure 2.43. Tree Fractal Pattern (Shiffman, 2010)

Fractals is a type of mathematical pattern that is characterized by its self-similarity and is defined in the Oxford English Dictionary as “curves or geometrical figures, each part of which has the same statistical character as the whole” (reference). Fractals are embedded within the patterns of shape found in nature, which creates intricate and beautiful structures that stimulates visual pleasure in human beings.

For this reason, it is clear that shape, and the repetition and variation of shape, has the ability to affect the visual experience of a person and can therefore be used in retail spaces to induce a desired atmosphere.

“I wonder whether fractal images are not touching the very structure of our brains. Is there a clue in the infinitely regressing character of such images that illuminates our perception of art? Could it be that a fractal image is of such extraordinary richness, that it is bound to resonate with our neuronal circuits and stimulate the pleasure I infer we all feel?”

P.W. Atkins (Bourke, 2001)

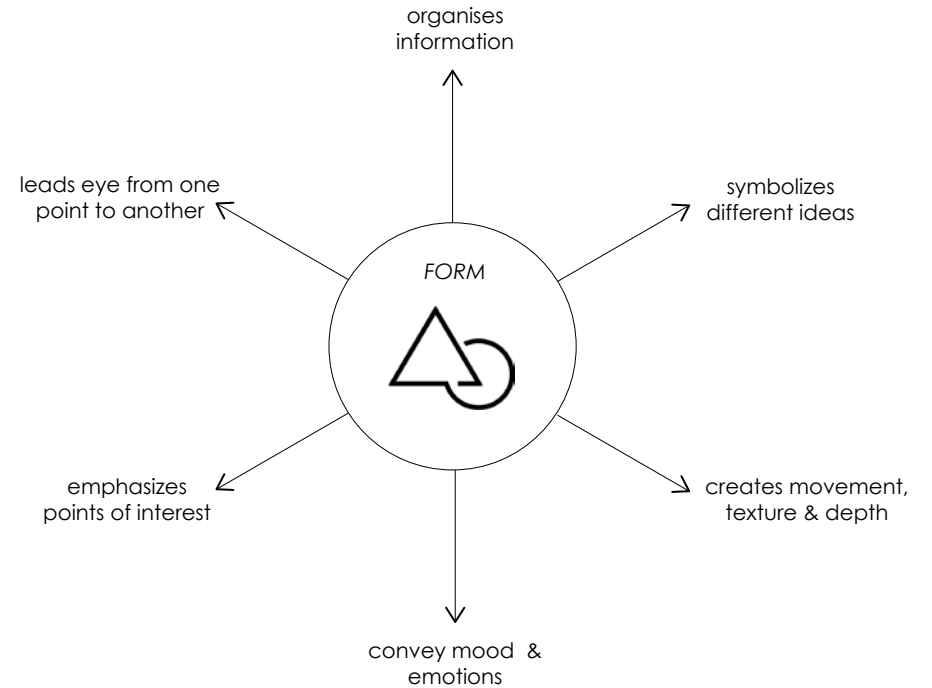

Figure 2.44. Influence of form on atmospheric qualities (Author, 2016).

[P10] COMPLEXITY & ORDER

According to Justema (1978), it is human nature to be drawn to patterns. Patterns are created through repetition of shape, which promotes consistency and familiarity – both of which are important to the human psyche. Repetition of shape creates a welcomed sense of order however, variation in pattern satisfies our need for visual imperfection. Variation relieves the mechanical and monotonous nature of patterns and adds visual interest, which is what makes the pattern pleasing to the viewer (Justema, 1978).



Audio Stimuli

Auditory stimuli and their relative associations prove to have a significant impact on the perceived atmosphere and experience of a space (Hussain, 2014). Soundscaping in a retail setting is the process of controlling noise and accentuating favourable sounds and music to enhance the retail experience.

Music plays a vital role in retail spaces and has the ability to influence shoppers' psychological arousal (Mattila & Wirtz, 2001). Studies have shown that the rhythm and tempo of music can have an affect on the speed at which shoppers move through a space. It has also been proven that the tempo of music has a direct correlation to a person's mood, in which music with a fast tempo will energize and excite whilst music with a slower tempo will calm and relax shoppers.

Kopec (2006: 307) suggests that music can be used to create comfortable and inviting environments that encourage social interaction through reducing the negative effects of silence and by masking unpleasant background noises. It is also proposed that music in retail environments should only be incorporated as background music that adds to the atmosphere on a subconscious level and should not attract attention, but instead encourage shoppers to linger and enjoy their shopping experience.

Furthermore, research has shown that exposure to nature sounds provides positive psychological and physiological affects and can greatly reduce stress, cognitive fatigue and even helps to motivate a person (Alvarsson et al, 2010). The use of nature sounds in an interior space will therefore be most beneficial for creating a relaxing and calming atmosphere.



THE EXPERIENCE

[P2] NON-VISUAL CONNECTION WITH NATURE (AUDITORY)

A space with a good auditory connection with nature provides positive psychological and physiological effects on the user that reduces stress and creates a calming and relaxing atmosphere.

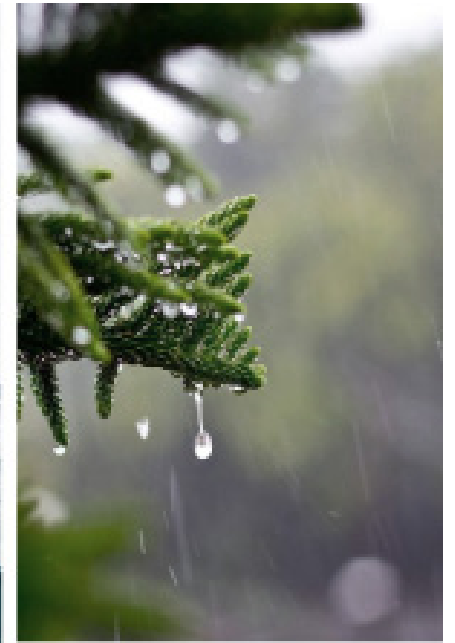
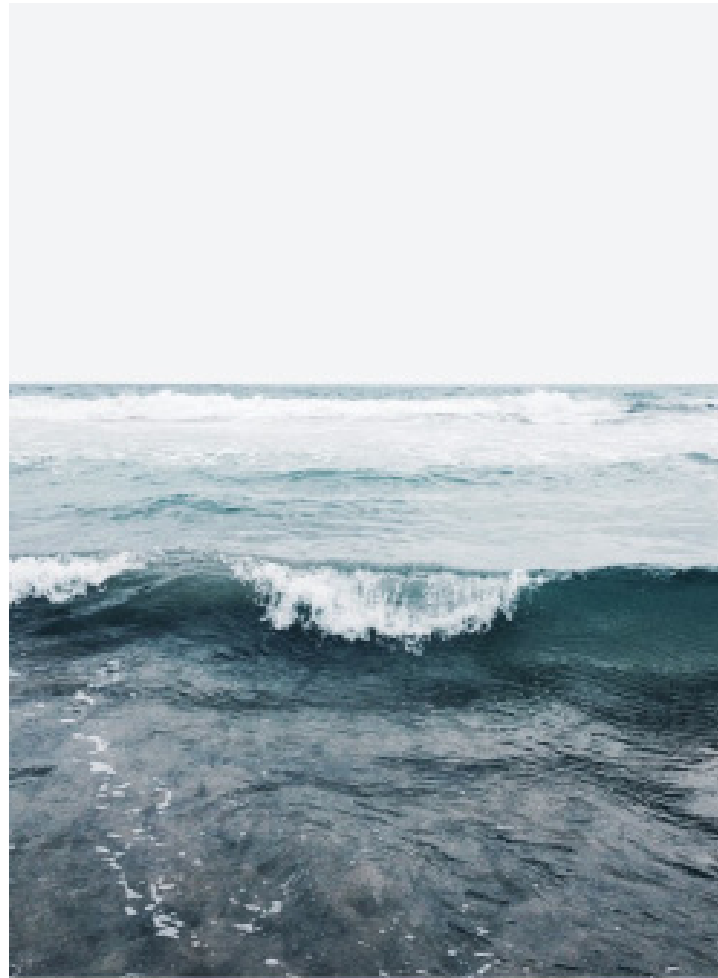

Figure 2.45. Auditory Connection with Nature: Water, wind, birds etc (Kostreva, 2016).



Tactile Stimuli

The patterns in nature that are associated with tactile stimuli consist of [P2] *NON-VISUAL CONNECTION WITH NATURE*, [P4] *THERMAL & AIRFLOW VARIABILITY* and [P9] *MATERIAL CONNECTION WITH NATURE*. Each of these different tactile stimuli contributes to the atmosphere of a space and can be manipulated to influence the in-store brand experience in a retail space.

[P2] *NON-VISUAL CONNECTION WITH NATURE (TACTILE)*

Browning (2014) suggests that non-visual connections with nature through touch provides both physiological and psychological benefits that reduces stress, lowers blood pressure and promotes well-being and tranquility. A study showed that this positive response to interaction with plant life was only achieved through touching of real plants and did not show the same positive outcome when subjects were exposed to synthetic plants (Browning, 2014). This suggests that people are very sensitive and tuned in to textures even though it might only be on a subconscious level.

[P4] *THERMAL & AIRFLOW VARIABILITY*

Various studies have been carried out which investigate the effects of ventilation and temperature on occupants in a space. The research shows that people respond positively to moderate sensory variability of airflow and temperature (Heerwagen, 2006). According to Heerwagen (2006) and Wigö (2005), the natural movement of airflow through a space mimicking the softness of a breeze has a positive impact on the comfort level of occupants and will create a fresh and invigorating atmosphere.

[P9] *MATERIAL CONNECTION WITH NATURE*

A material connection with nature is manifested through the use of natural and raw materials. Natural materials such as wood, bamboo, cork and stone as well as fabrics such as cotton, linen and wool exude a warm richness that provides a sense of comfort to the human psyche.



Figure 2.46. Tactile Stimuli: Natural textures (Schmidt, 2016)



THE EXPERIENCE

[P2] *NON-VISUAL CONNECTION WITH NATURE (TACTILE)*

A space with a good Non-Visual Connection with Nature feels fresh and well balanced; the ambient conditions are perceived as complex and variable but at the same time familiar and comfortable, whereby sounds, aromas, and textures are reminiscent of being outdoors in nature.

[P4] *THERMAL & AIRFLOW VARIABILITY*

A space with good Thermal & Airflow Variability feels refreshing, active, alive, invigorating and comfortable. The space provides a feeling of both flexibility and a sense of control.

[P9] *MATERIAL CONNECTION WITH NATURE*

A space with a good Material Connection with Nature feels rich, warm and authentic and sometimes stimulating to the touch.

Figure 2.5.8: Non-Visual Connection with Nature: Tactile Experience (Author, 2016)



Olfactory Stimuli

Social learning theory suggests that scents and aromas have strong associations with people, places and ideas and is connected to creating and retrieval of memories (Goldstein, 2002). It is therefore a very powerful tool that can be used in the design of retail spaces to provide non-visual clues about the atmosphere and even branding of the space.

Olfaction is a technique that manipulates the use of scents and smells to attract shoppers into a store (Kopec, 2006). For instance, the smell of freshly baked bread drifting out through the open doors of a bakery will awake appetites and entice people to enter the bakery. Similarly, beauty stores often use the scents of burning candles to release soft floral smells that would attract customers to enter the store and view the products.

The use of natural smells in an indoor setting creates a non-visual connection with nature that has a calming and energizing effect on people. Research has shown that the natural scents of herbs captured in essential oils promotes healing and rejuvenation (Li et al, 2012).

Therefore, the careful use of scents and smells can be manipulated to create a desirable atmosphere and brand experience that will elicit positive feelings and memories in shoppers.



THE EXPERIENCE

[P2] NON-VISUAL CONNECTION WITH NATURE (OLFACTORY)

A space with an olfactory connection with nature creates a calming and energizing atmosphere that promotes healing and rejuvenation.



Figure 2.47. Olfactory Sensory Stimuli: Oil Diffuser (Gardeners, 2016)



Gustatory Stimuli

Gustatory experiences in a retail environment are usually limited to specific sectors that deal with food such as restaurants and supermarkets. However, Leone (2008) suggests that there is value in introducing taste as part of a holistic sensory experience in other retail sectors too – “Food and taste can make a space feel more inviting and welcoming. We recommend creating public waiting rooms that have fresh natural food offerings such as pitchers of water with lemons or cucumber slices and offerings of fresh fruit. It is a way to support health and relaxation” (Leone, 2008).

When consumed, natural and earthy ingredients such as fresh fruit, vegetables and herbs have the innate ability to leave you feeling revitalized and invigorated. Therefore, incorporating a gustatory experience within a retail space can contribute to the perceived atmosphere of the store.



THE EXPERIENCE

[P2] *NON-VISUAL CONNECTION WITH NATURE (GUSTATORY)*

A space that incorporates a gustatory experience using fresh and natural ingredients has the ability to relax, revitalise and invigorate occupants.



Figure 2.48. Gustatory Sensory Stimuli: Fresh Herbs and Fruit (Cochrane, 2015; Verdina, 2013)



THE PROBLEM

DEFINE

The first part of Chapter 3 aims to investigate and analyse the **Real World Problem**, which is the environmental impact of building construction. The second part of this chapter identifies the **Design Problem** which entails the client and site analysis.

03

3.1 THE REAL WORLD PROBLEM



Figure 3.1. Environmental degradation (Fetrow, 2011)

3.1.1 THE GLOBAL PROBLEM

The conservation of our environment has been an issue since the industrial revolution in the late 19th century (Dykstra, 2008). The economic boom gave rise to a consumerism lifestyle that essentially depletes natural resources faster than it can be replenished, and discards such resources in the form of waste when the consumed product has reached the end of its lifecycle. This presents two ends to the environmental problem that is currently faced by the 21st Century society. This problem will be explained using the analogy of a tap and a sink.

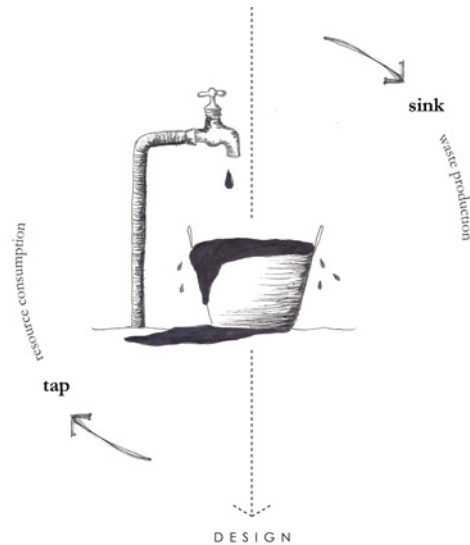

Figure 3.2. Tap and Sink Analogy: Showing resources consumed and waste produced (Author, 2016)

"Modern man does not experience himself as a part of nature but as an outside force destined to dominate and conquer it. He even talks of a battle with nature, forgetting that if he won the battle, he would find himself on the losing side. Until quite recently, the battle seemed to go well enough to give him the illusion of unlimited powers, but not so well as to bring the possibility of total victory into view. This has now come into view, and many people, albeit only a minority, are beginning to realize what this means for the continued existence of humanity"

- Pearce, 1978

The first end of the environmental problem is natural resource depletion, i.e. the tap. The tap represents the way in which natural resources are extracted from the earth for human consumption, production and manufacturing purposes (Magdof, 2013). Natural resources are being 'tapped' at an alarming rate. It is a fact that on average, every person uses 16 kilograms of natural resources extracted from the earth on a daily basis (The World Counts, 2015). This is not something to be taken light-heartedly, considering that the human population has already surpassed 7 billion and is rapidly growing, suggesting that the demand for resources will only increase (The World Counts, 2015).

Natural resources are categorized either as renewable or nonrenewable (EPA, 2013). The supply of renewable resources such as energy from the sun and wind is infinite and can be recycled or replenished at approximately the same rate at which it is harvested. Timber is also considered a renewable resource, however the rate at which timber is farmed often exceeds the rate at which it can be regenerated. Nonrenewable resources, for instance coal, iron ore and bauxite are finite in their supply and cannot be replenished once extracted from the earth (EPA, 2013). Both renewable and nonrenewable resources are invaluable for production and manufacturing purposes, which is why it is important for these resources to be used efficiently and sparingly to prevent total depletion of supply.

The second end of the environmental problem is the excessive quantities of waste and pollutants produced through processing of natural resources, which cannot be filtered or absorbed by the earth i.e. the sink (Magdof, 2013). Ultimately, the sink is overflowing with waste and pollutants that are very harmful to the natural environment and its ecosystems.

The two ends (tap and sink) of the environmental issue are directly correlated with one another (Magdof, 2013). Natural resources that are extracted from the earth are used as raw materials for manufacturing of goods. Energy often in the form of burning fossil fuels is required to manufacture such goods, which produces harmful air pollutants and greenhouse gases as a by-product. These greenhouse gases become trapped within the earth's atmosphere and ultimately contribute to climate change (EPA, 2013). The effects of climate change are very serious and could prompt natural disasters such as droughts, flooding and the spread of disease. Climate change could also disturb vegetation growth patterns and could possibly put ecosystems out of balance (EPA, 2013). Since life on earth is directly dependent on the state of the natural environment, it is essential that we as human beings do everything in our power to protect and conserve it for present and future generations.

3.1.2 THE ENVIRONMENTAL IMPACT OF BUILDING CONSTRUCTION

The building construction industry is a major contributor to the environmental problems we are faced with today. It is responsible for 20% of global greenhouse gas emissions, mainly caused by transportation of building materials and burning of fossil fuels to create energy for building construction. It also contributes to 50% of global energy usage, which is more than any other industrial sector (Moxon, 2012). Additionally, buildings contain large amounts of embodied energy due to the processes involved in construction including extraction of raw materials, processing and manufacturing thereof, transportation of materials to site, construction and maintenance of buildings.

The built environment also plays a large role in depletion of natural resources and is accountable for 40-50% of global raw material flow (Moxon, 2012). This totals to 3 billion tons of raw materials used annually. The rate at which these natural resources are being depleted is extremely detrimental to the state of the environment as well as the ecosystems that depend on these resources.

Due to the impact of building construction, sustainable practice in the built environment has become a prerequisite. Environmental sustainability is defined as the “responsible interaction with the environment to avoid depletion or degradation of natural resources and allow for long term environmental quality”. Through practicing environmental sustainability, we as professionals of the built environment help to ensure that the needs of today’s population is met without jeopardizing the future generation’s ability to meet their needs (Moxon, 2012).

Interior design forms part of the built environment industry and therefore also contributes to the negative impacts caused by building construction. It is an industry that is routinely involved with adaptations and renovations of interior spaces, a process that can be resource and energy intensive (Moxon, 2012).

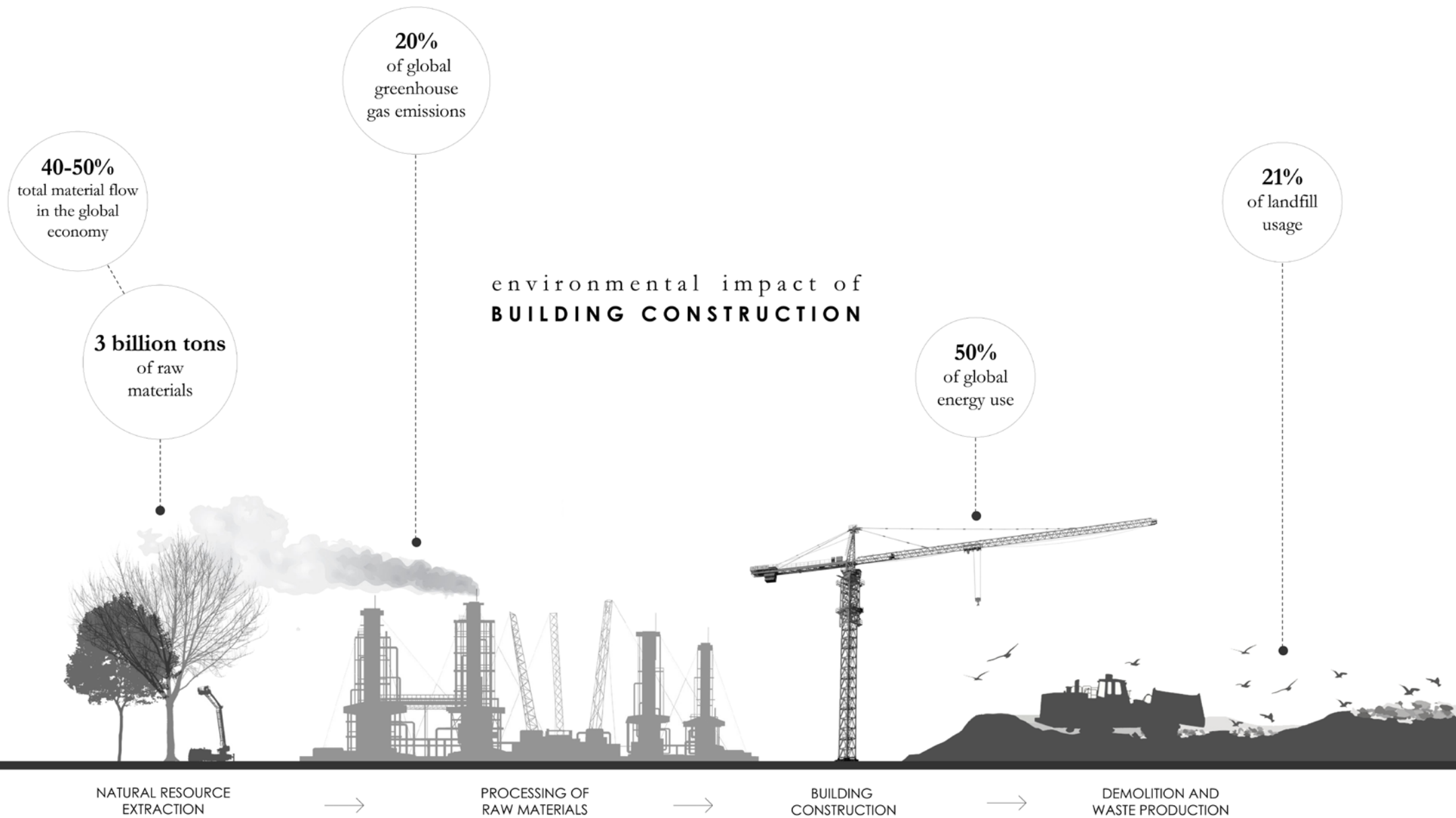

Figure 3.3. Environmental impact of building construction (Author, 2016).

3.2 THE DESIGN PROBLEM

3.2.1 CLIENT ANALYSIS

Margaret Roberts is a very well-known and inspirational South African figure. She is a Herbalist that practices natural healing methods with medicinal herbs that is manifested in the form of skincare and culinary products. She is recognized for her informative lectures, radio talks and a large collection of published books on herbs and their medicinal uses. Her extensive research and invaluable contribution to the field of herbs has earned her a Laureate Award from the University of Pretoria (Natural Medicine, Sa).

Growing up on a farm, Roberts has always been fascinated by nature, but it is only in her adult years as a mother that she became really infatuated with the medicinal and healing properties of herbs (Roberts, 1984). She is passionate about passing on her knowledge and teaching the public to incorporate herbs into their daily lives.

Roberts may be a senior citizen but that hasn't stopped her from perusing her goals. She is currently the founder and owner of the Margaret Robert's Herbal Centre in the Hartbeespoort region of Pretoria. The Herbal Centre is divided up into several different areas including herbal gardens, a nursery, restaurant, apothecary, labyrinth, chapel, sand garden and her skincare shop (Margaret Roberts, n.d).

Justification of Chosen Client

This dissertation is conducted under the environmental potential research field, which is why it is imperative to work with a client that supports sustainable practices. Margaret Roberts is therefore an ideal client since she is very concerned with the preservation of our natural environment and has already adopted sustainable practices at her Herbal Centre (Margaret Roberts, n.d) such as rain water harvesting.



"Tranquility is quickly and easily found by sitting quietly in the herb garden, resting the eyes on the soft, muted greens, grays and blues of the healing plants"

- Margaret Roberts (Roberts, 1984)

Figure 3.4. Client: Margaret Roberts (Margaret Roberts, n.d).



Figure 3.5. Margaret Roberts Herbal Centre (Author, 2016).

Organic Skincare Product Range

Margaret Roberts has a wide selection of organic skincare products that is categorized into the following six groups; *ESSENTIAL OILS*, *MEDICINAL CREAMS*, *GENERAL CREAMS*, *BATH & SHOWER PRODUCTS*, *TISSUE OILS* and last but not least a *MEN'S RANGE*. Figure 3.7 shows a comprehensive breakdown of the products that fall under each of the above-mentioned groups.

The essential oil collection is at the heart of Margaret Robert's organic skincare range and forms the foundation of most of her skincare products. Lavender is amongst one of her best-selling essential oils and has become a trademark to her skincare products. Margaret Roberts has a species of lavender (*Lavandula X Intermedia*) registered to her name which is often referred to as Lavender Margaret Roberts (Haakdoorn Nursery, 2016). Lavender is an incredible medicinal healing plant that offers countless benefits, such as reducing stress, insomnia, and depression and can also be used as an anti-septic and anti-inflammatory treatment (Nordqvist, 2014).



HEALING PROPERTIES OF LAVENDER

- Antiseptic
- Anti-inflammatory
- Reduces stress
- Reduces insomnia
- Reduces depression
- Aids digestion
- Relieves headaches

LAVANDULA X INTERMEDIA

(Nordqvist, 2014)

Figure 3.6 Lavandula X Intermedia (Author, 2016).

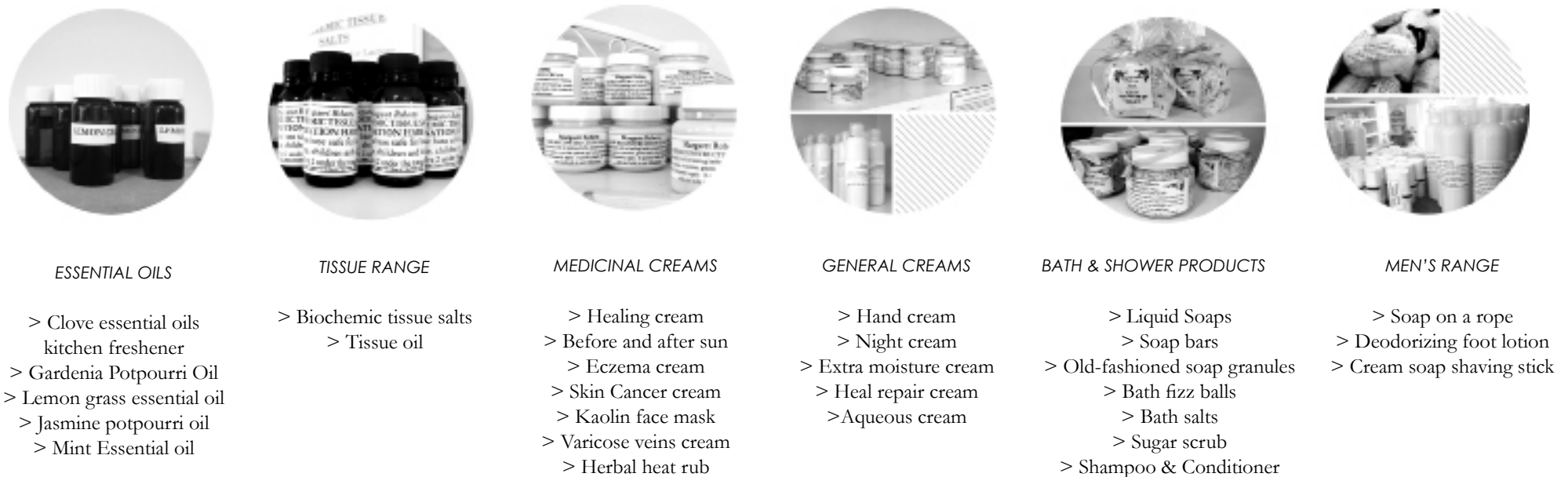

Figure 3.7. Margaret Roberts product range (Author, 2016).

Essential Oil Distillation Process

Steam distillation is the method used to extract the essential oils from the organic plant matter. This method of essential oil extraction is most favourable for its wide application to an array of organic matter as well as its ability to carry out quality control in the process of extraction. Steam distillation allows you to control the temperature and pressure of the steam that is applied to the plant material, essentially minimizing the degradation of the delicate botanical oils to be extracted.

STEP 1:

The boiling flask is filled with distilled water and brought to boiling point. The steam from the distilled water will enter the biomass flask; heating the organic matter to release the essential oils.

STEP 2:

The steam from the boiling flask heats up the organic matter, allowing the release of essential oils in the form of water vapour.

STEP 3:

The water vapour from the biomass flask travels up through the glass delivery tubes towards the west condenser.

STEP 4:

The water vapour containing essential oils enters the west condenser. Cold water is then flushed through the outer wall of the glass condenser, allowing the water vapour to turn into water droplets.

STEP 5:

These water droplets are made up of floral water (hydrosol) and essential oils. The floral water is separated from the essential oils and is collected in a conical flask. This floral water does contain small traces of the essential oils and can be used for water-based fragrances.

STEP 6:

The essential oils are separated from the floral water through the separatory funnel and are collected in a glass jar that can be sealed.

YIELD AND WASTE

The essential oil distillation process is resource intensive which uses large quantities of fresh lavender and only yields 0.5 to 1% essential oils (Essential Oil, 2016). The leftover organic material is a type of straw that is regarded as waste.

This creates an opportunity to apply nature's zero-waste principles by developing a strategy that reuses this lavender straw/waste product as a resource.



WASTE PRODUCED
Lavender Straw

Figure 3.8. Lavender Straw Waste (Snowy River Lavender, 2016).

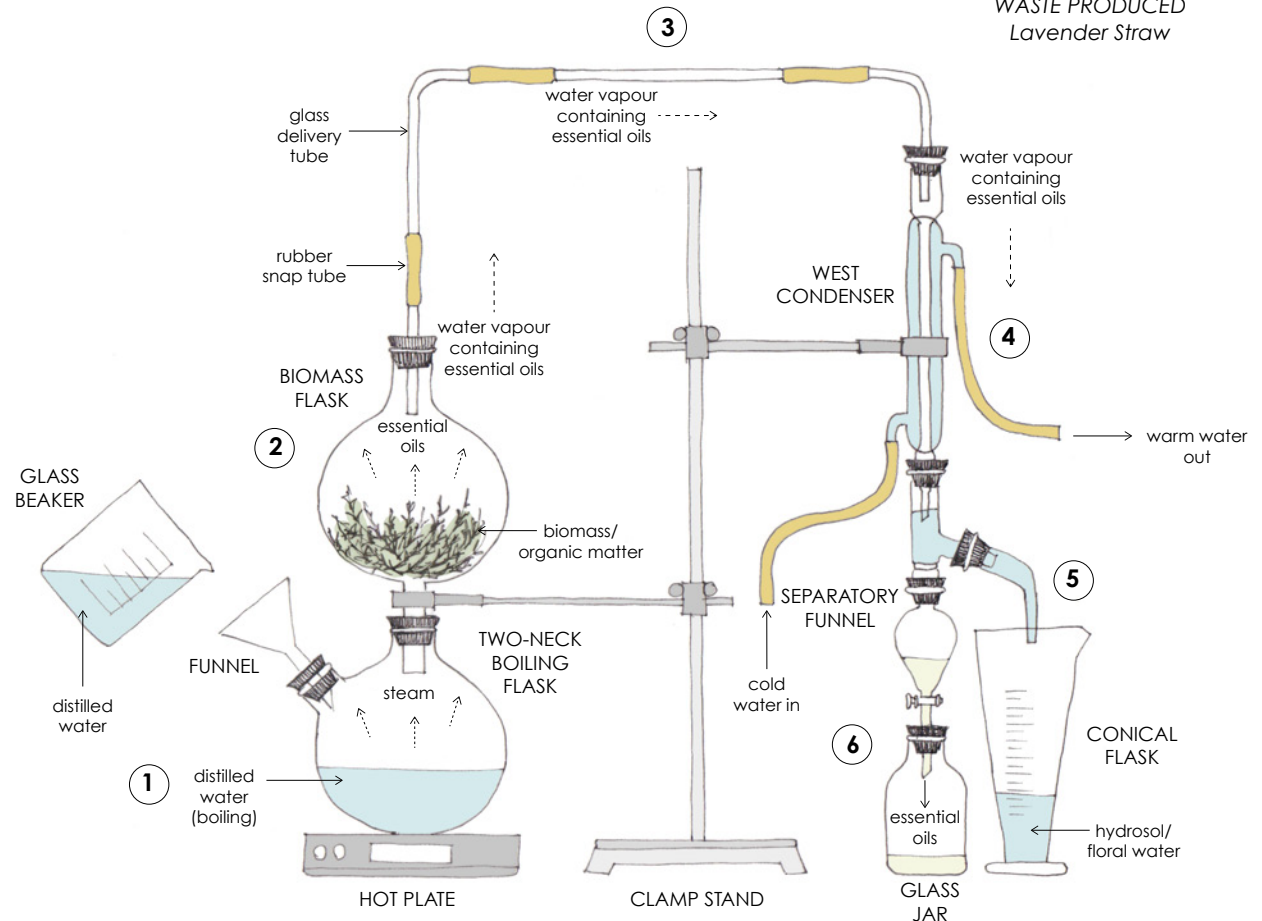

Figure 3.9. Diagram of Lavender essential oil distillation process (Author, 2016).

3.2.2 EXISTING BRAND ANALYSIS

Margaret Roberts' current product and in-store design shows little consideration to branding. Theories discussed in Chapter 2 highlight the significance of branding and the role it plays in creating a corporate identity. This corporate identity reflects the core values of the company and should be evident throughout all design aspects.

Since Margaret Roberts does not have an existing company profile, information will be collected and analysed from her series of published books and the branding of her existing product range and skincare store in order to establish what the Margaret Roberts brand needs to encompass.

CURRENT PRODUCT BRANDING

Margaret Robert's product range shows little evidence of a brand identity. It appears as though Margaret Roberts' name itself is used as the brand identifier on the packaging but is not consistent throughout. Many of the products are bottled in amber glass bottles to preserve the quality of its contents. These amber glass bottles create medicinal associations with the products.



Figure 3.10. Margaret Robert's current product branding (Author, 2016).

CURRENT STORE DESIGN AND BRANDING

The design of Margaret Roberts' existing store attempts to create associations with nature through the lavender colour scheme and incorporation of fake plants. However this attempt is not successful and can be executed better through careful design considerations.



Figure 3.11. Margaret Robert's existing store (Author, 2016).

MARGARET ROBERTS PUBLISHED MATERIAL

Margaret Roberts' published material provides better insight to the essence of her brand. The botanical illustrations drawn by Margaret Roberts; evident throughout her published material, is suggestive of the medicinal quality of her skincare products.

These illustrations will be incorporated into the new brand identity to maintain the botanical association with the skincare products.

Curry bush

Helichrysum species

ENGLISH Everlastings
AFRIKAANS Hottentotskoigoed,
Hottentotskoigoed,
Hottentotsbedding,
sewagartjies, kerrieboes



THE name Hottentotskoigoed covers several species under the genus *Helichrysum*. The leaves are usually a soft grey and curry-scented, the stems are soft and the shrub scrambles or makes a dense groundcover, spreading attractively over rocks or down hillsides. The saganat Khoikhoi, or Hottentots, used the soft leaves and flowers as bedding, hence the name, and campers still do this today. The pleasant smell the leaves give off aids sleep, and the profusion of growth in the coastal areas makes it an easily accessible plant for hikers and campers. It grows at its best invigilously usually within 14 km of the sea, but through the years some nurseries have started propagating it and it grows well even in the Transvaal with its dry winters and summer rainfall.

There are several medicinal uses for the *Helichrysum* species and those living in the Cape could start a fascinating collection, as they all make lovely garden subjects. Here are a few to get you started.

Helichrysum auriculatum

A pleasant and health-giving tea is made from this plant (1/2 cup of fresh leaves and stems steeped for 3 to 5 minutes in 1 cup of boiling water, then strained and sweetened with a little honey if desired, is the standard brew) as a treatment for backache, kidney diseases and kidney stones and heart ailments. It was once used as a daily tea in the Cape by the colonists and the Khoikhoi, and was a very much respected drink.

76

Helichrysum crispum

A tea made of the leaves (standard brew) is drunk for heart conditions, kidney ailments and backache. It calms a racing heart, and is said to be effective for coronary thrombosis and hypertension. The Khoikhoi used it as a calming tea and introduced it to the colonists in this way. It is also an effective heart treatment for animals.

Helichrysum foetidum

The leaves warmed and washed in water make an excellent poultice for a fevering, infected sore, as they have astringent qualities which draw out the infection. The leaves and flowers are aromatic and are used in pot-pourris and in bedding and pillows.

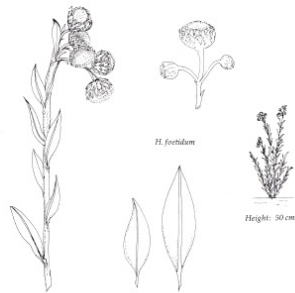

77



Figure 3.12 Margaret Roberts' published material (Roberts, 1984).



3.2.3 MARGARET ROBERTS' BRAND ESSENCE

The essence of Margaret Roberts' brand is distilled from a collection of extracts from her published material. These extracts provide an insight to the intention behind her medicinal/herbal products.

In her book *Indigenous Healing Plants*, Margaret Roberts writes;

"Surely this must be one of the reasons why the wild things show so few illnesses and growth problems? Smell the summer night. The heat of the day will have released aromatic oils of all the fragrant herbs and flowers. Breathe deeply and rhythmically; let all those cares of the day fall away."

- Margaret Roberts (Roberts, 1984; iv)

"My intention is not to prescribe plant medicines for curing afflictions, nor am I trying to replace the doctor; rather I wish to reveal the amazing wealth in our green heritage and the wonderful uses that the plant kingdom has given us"

- Margaret Roberts (Roberts, 1984; xi)

It is evident that Margaret Roberts is fascinated with organic herbs, their healing properties and more so the tranquility and rejuvenation gained from interacting with these herbal plants.

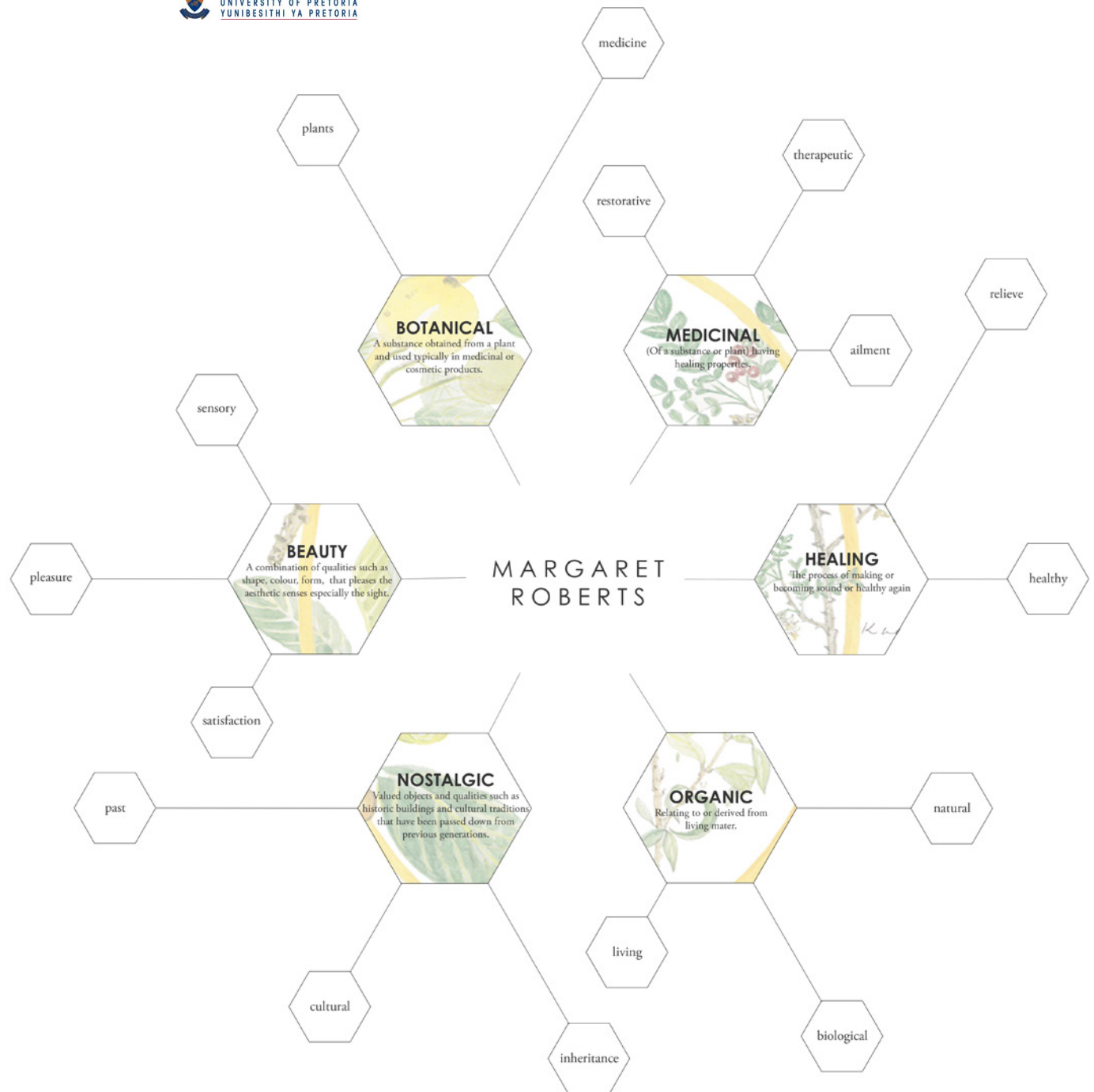

Figure 3.14. Margaret Roberts brand essence diagram (Author, 2016).

3.2.4 SITE SELECTION

This dissertation focuses on the design of a skincare servicescape for Margaret Roberts, which in essence should be able to fit various retail locations. The type of retail location in which the servicescape is situated plays a role in the associations formed with the brand, and should therefore be carefully considered. Smaller retail locations such as community malls and lifestyle centers; which are not enclosed retail spaces, are ideal settings for the Margaret Roberts skincare servicescape. Community malls and lifestyle centers generally house a variety of different stores supported by one or two anchor stores.

The following site requirements have been identified to create a guideline for selecting retail sites appropriate for the Margaret Roberts skincare servicescape.

Where possible, the retail site should:

- > Be lifestyle orientated
- > In an open/outdoor space
- > Showcase artisan qualities
- > Be a healthy site which provides access to natural light and ventilation.

The following sites have been identified as suitable for the Margaret Roberts skincare servicescape:

WATERKLOOF CORNER

Main Str, Pretoria

Waterkloof corner is lifestyle-orientated neighbourhood center that is home to a variety of artisan and boutique stores. This site would be suitable for Margaret Roberts' skincare store since it is in an open/outdoor center; providing access to natural light and ventilation and also exhibits artisan qualities that will contribute to the brand associations with Margaret Robert's skincare store.



Figure 3.15. Waterkloof Corner Shopping Centre (Author, 2016; Advanced Building, 2012).

SOUTH DOWNS

John Voster Dr, Pretoria

South Downs is a lifestyle center located on John Voster Drive, Pretoria. This center showcases many of the desired site requirements, including the fact that it is a lifestyle center; it is in an open/outdoor space and shows farm-style artisan qualities, which would contribute positively to the Margaret Roberts brand image. South Downs has existing skincare stores, which suggests that proposing a skincare store for Margaret Roberts in this location would be feasible.



Figure 3.16. Southdowns Shopping Centre (Southdowns, 2016).

IRENE MALL

Nelmapius Dr, Centurion

Irene Mall is a lifestyle community mall that offers a unique outdoor shopping experience. This mall would be a suitable site for Margaret Roberts' skincare servicescape since it meets the desired site requirements including the fact that it is an outdoor mall, it showcases artisan qualities, it is lifestyle orientated and provides access to natural light and ventilation. This site would therefore contribute positively towards the brand identity of Margaret Roberts skincare servicescape.



Figure 3.17. Southdowns Shopping Centre (Southdowns, 2016).

3.2.5 CHOSEN SITE

IRENE MALL

Nelmapius Dr, Centurion

Macro Context

The site that was chosen for Margaret Roberts' skincare servicescape is Shop 150 located in Irene Mall, Pretoria. Irene Mall is a lifestyle community mall that meets the site requirements set out for Margaret Roberts' store. It is an open/outdoor mall that provides stores with access to natural light and ventilation and also showcases farm-style artisan qualities. Irene Mall was favoured above other possible sites since it provides double volume retail spaces, which can be utilized to create a mezzanine level that will allow separation of product and service areas in the design of the Margaret Roberts skincare store.

Irene Mall is located in Nelmapius Drive, Centurion and is situated within a residential area. It is within close proximity to a main road (R21), which provides easy access to the mall.

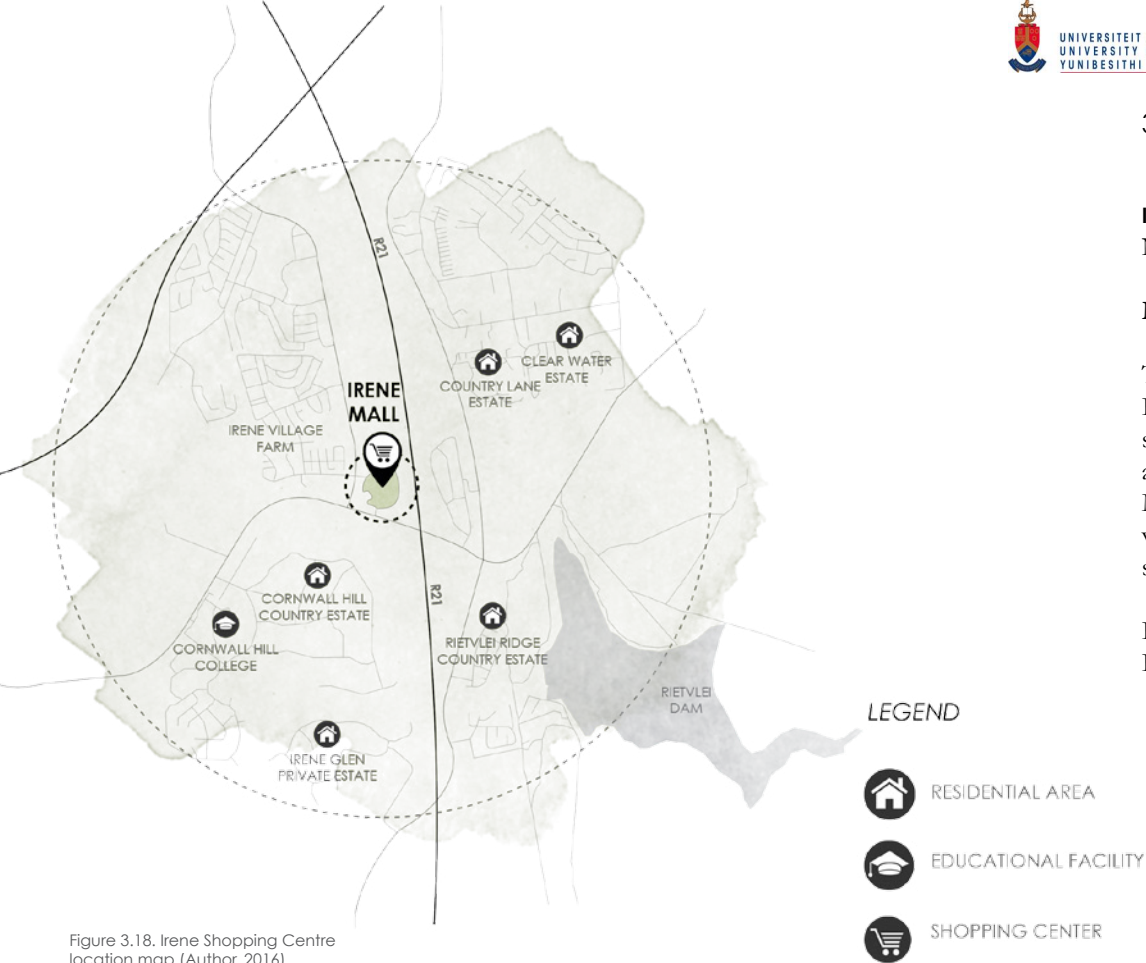

Figure 3.18. Irene Shopping Centre location map (Author, 2016).



Figure 3.19. Irene Shopping Centre (Author, 2016).

Micro Context

Shop 150 is located in the northern wing of the mall (see Figure 3.21) in a more secluded area. This space was chosen since the Margaret Roberts skincare store requires a relaxing and tranquil environment. Shop 150 is a 200m² double volume space that can be extended to 300m² by introducing a mezzanine level. This will be beneficial for separating retail and treatment areas within the store. The existing store currently has one main entrance and a secondary entrance door accompanied by four large shopfront windows that allow natural light to filter into the space.



Figure 3.20. Irene Shop 150 (Author, 2016).

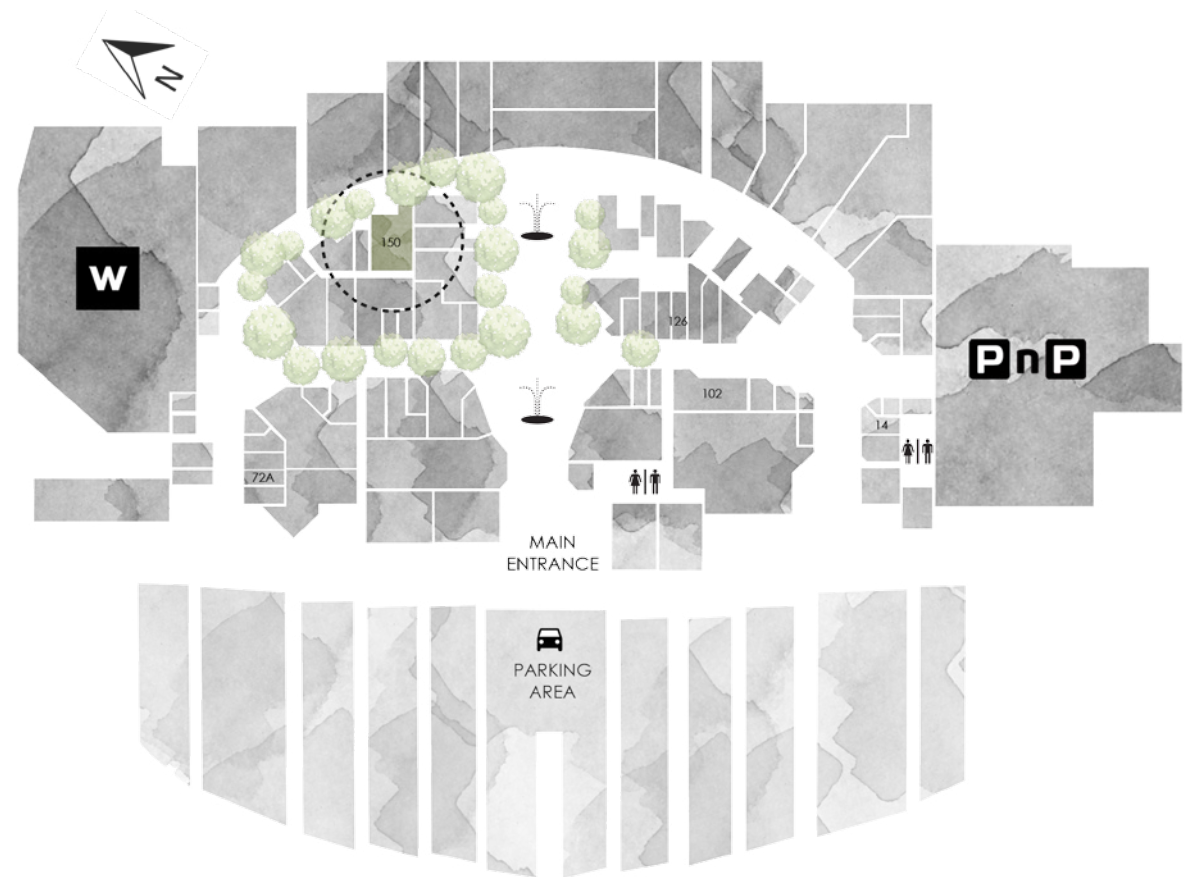

LEGEND



ANCHOR STORES

Woolworths **W**

Pick & Pay **PnP**

HEALTH & BEAUTY STORES

Shop 14 _ Placecol Skin Care Clinic

SHOP 72A _ Perfect 10

SHOP 126 _ Red Square

SHOP 102 _ Pharma Value



Trees



Public Toilet



Fountain



Parking

Figure 3.21. Irene Shopping Centre Mall Map - Indicating location of Shop 150 (Author, 2016).

Shop 150 Existing Structure

Since the site is a retail space, the existing structure is simply an empty shell that can be shop fitted according to the tenant's requirements. This retail space includes large shopfront windows that allow natural light to filter into the interior space. It is a double volume space which allows for a mezzanine structure to be introduced. Large trees are located outside the facade of Shop 150 which creates a visual connection with nature from within the store.

SHOP 150 FLOOR PLAN
not to scale

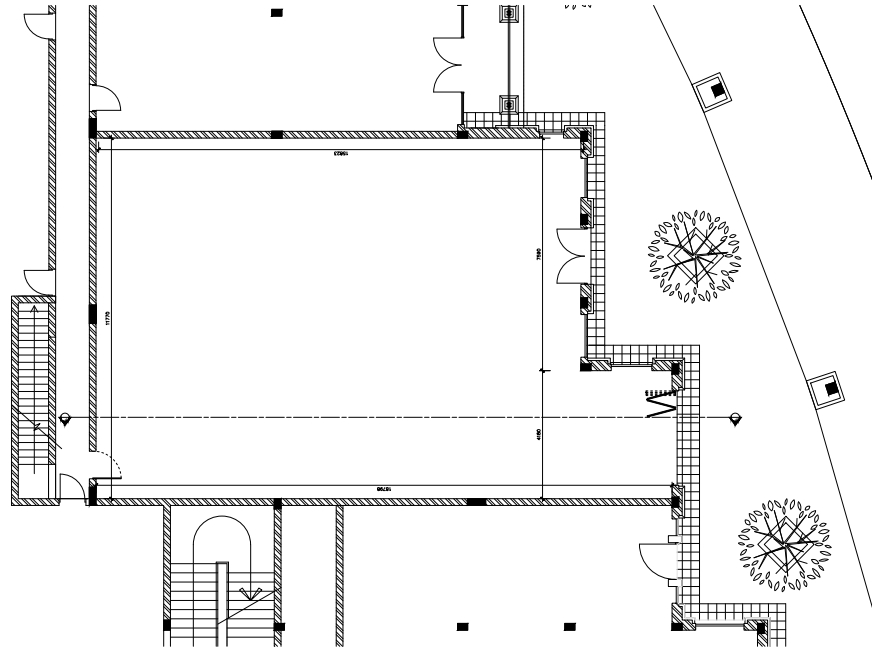

SHOP 150 SECTION
not to scale

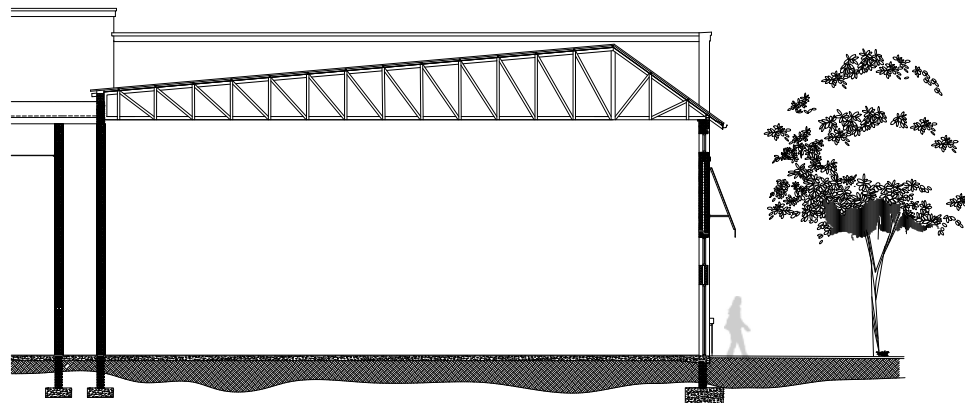

Figure 3.22. Shop 150 Floor plan and Section (Author, 2016).

EXISTING SHOP FRONT OF SHOP 150

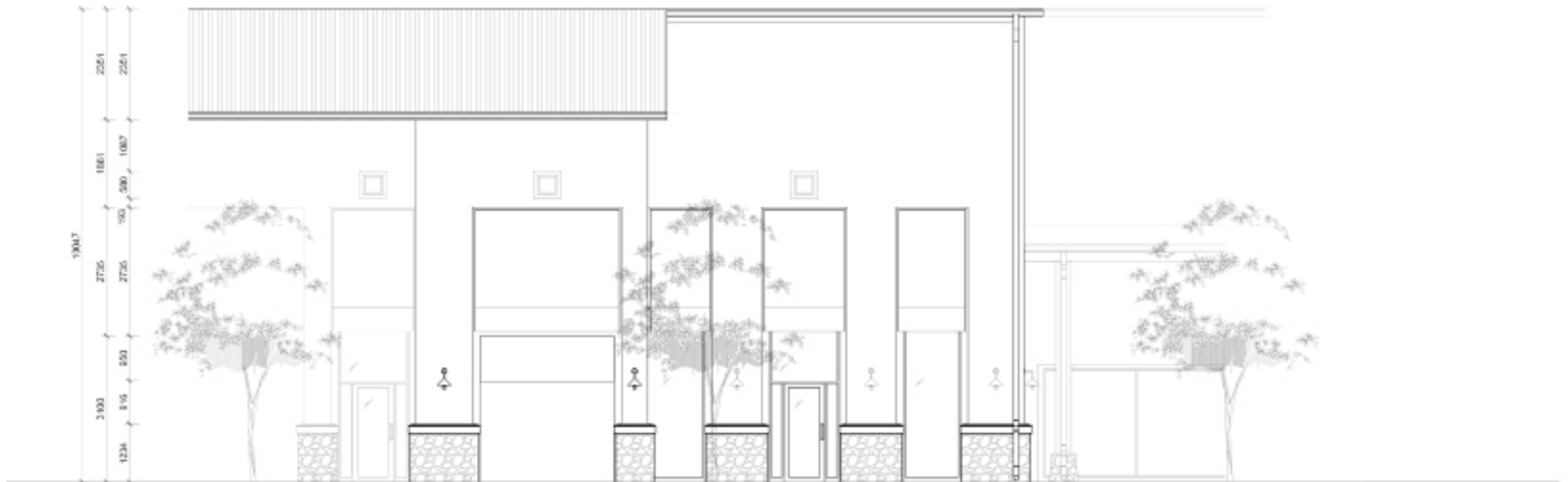
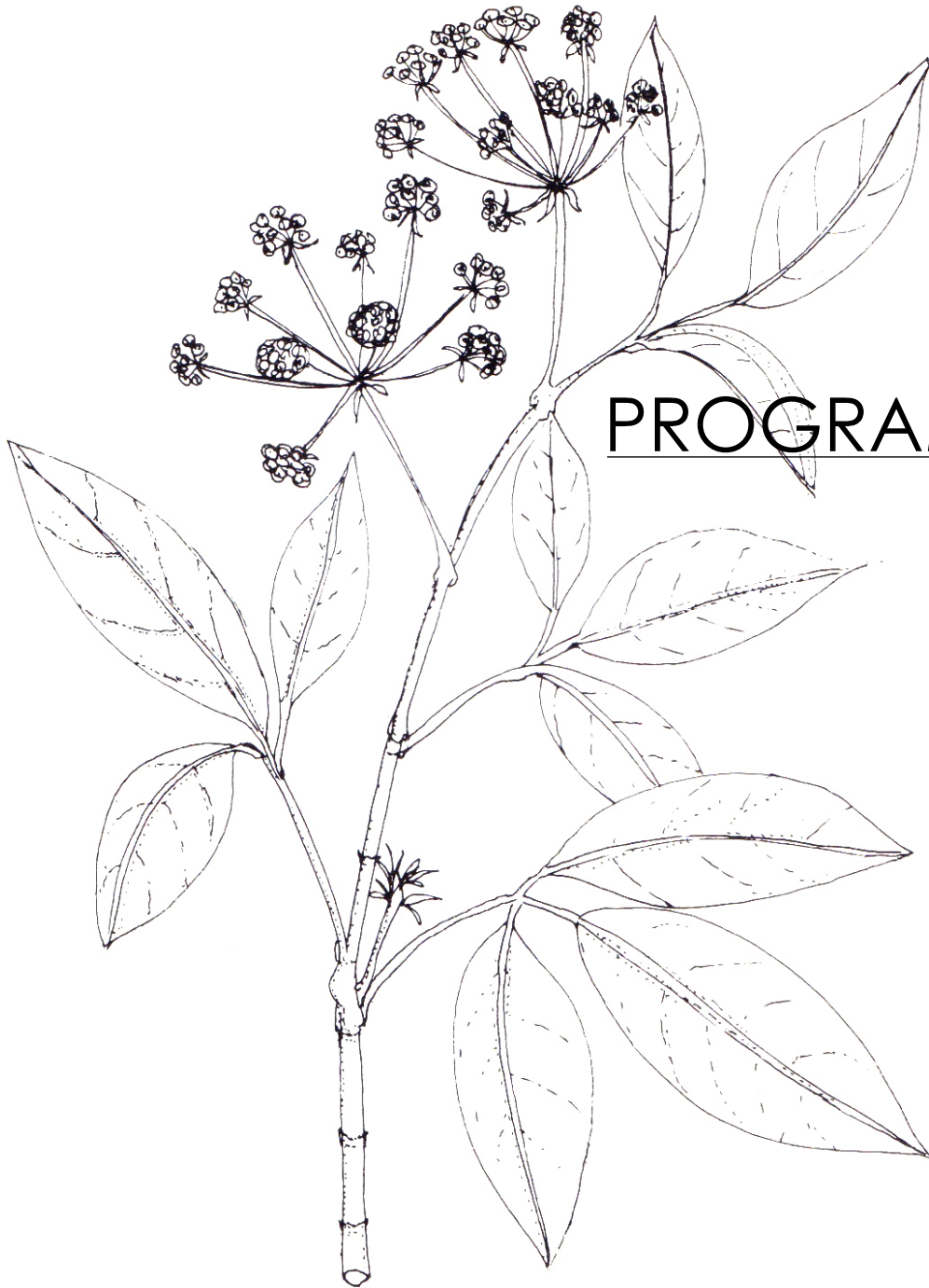

Figure 3.23. Shop 150 Existing facade (Author, 2016).



PROGRAMMATICAL REQUIREMENTS

IDENTIFY

Chapter 4 aims to investigate precedent studies of skincare stores that include both product and service elements (retail servicescapes); i.e selling of products and providing skincare treatment services, in order to determine the programmatical requirements for the new proposed Margaret Roberts skincare servicescape. The three precedents studies that will be analysed include Aesop, Jurlique and Dermalogica. These skincare brands have been chosen purely for programmatical investigation purposes and will not be studied for their branding.

The investigation of these precedent studies will allow deduction of typical “retail zones” that are included in skincare retail servicescapes. These retail zones will then form the proposed programmatical function of Margaret Robert’s skincare servicescape, and will be analysed further throughout this chapter.

04

4.1 SKINCARE RETAIL PRECEDENT

The following precedent studies are investigated to determine the programmatic requirements of a skincare retail servicescape.

Jurlique

Jurlique is a natural skincare range that sold in stores worldwide. The programmatic functions of these stores generally includes a facade/shopfront, vertical product displays, floor display units, point of sale, product testing areas as well as changing facilities and private treatment areas where spa treatments such as facials are carried out (Jurlique, 2016).

- > Facade/ Shopfront
- > Vertical product displays
- > Floor display units
- > Point of Sale
- > Product testing areas
- > Private treatment areas
- > Changing facilities



Figure 4.1 Jurlique skincare store design (Jurlique, 2016).

dermalogica®

Dermalogica is a dermatological grade skincare brand that offers professional skincare products and services (Dermalogica, 2016). The programmatic functions of Dermalogica stores generally includes a facade/shopfront, vertical product displays, point of sale, and designated service areas including the MicroZone, SkinBar and SkinTreatment areas (Dermalogica, 2016). The MicroZone is a semi-private treatment area, the SkinBar resembles an over-the-counter consultation/treatment space and the SkinTreatment areas are private rooms for full body treatments.

- > Facade/ Shopfront
- > Vertical product displays
- > Point of Sale
- > MicroZone
- > SkinBar
- > Skin Treatment Area



Figure 4.2 Dermalogica skincare store (Dermalogica, 2016).

Aēsop.

Aesop is a skin, hair and body care brand that combines plant-based and laboratory-made ingredients to formulate its products (Aesop, 2016). Aesop's unique range of concept stores can be found worldwide. These stores showcase programmatical functions such as a facade/shopfront, vertical product displays, floor display units, point of sale, product testing areas and often also includes private treatment facilities accompanied by waiting areas (Aesop, 2016).

- > Facade/ Shopfront
- > Vertical product displays
- > Floor display units
- > Point of Sale
- > Product testing areas
- > Private treatment areas
- > Waiting area

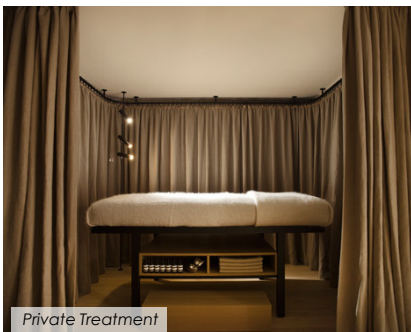
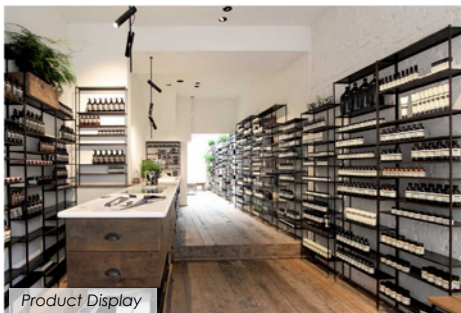

Figure 4.3. Aesop skincare store (Aesop, 2016).

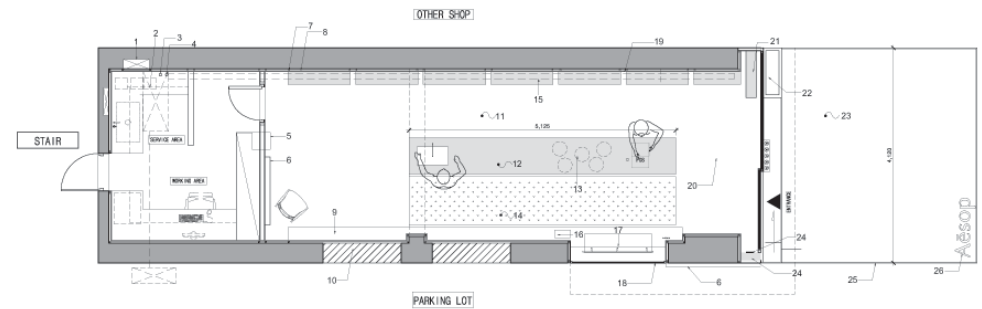

Figure 4.4 Aesop skincare store floor plan 1 (Aesop, 2016).

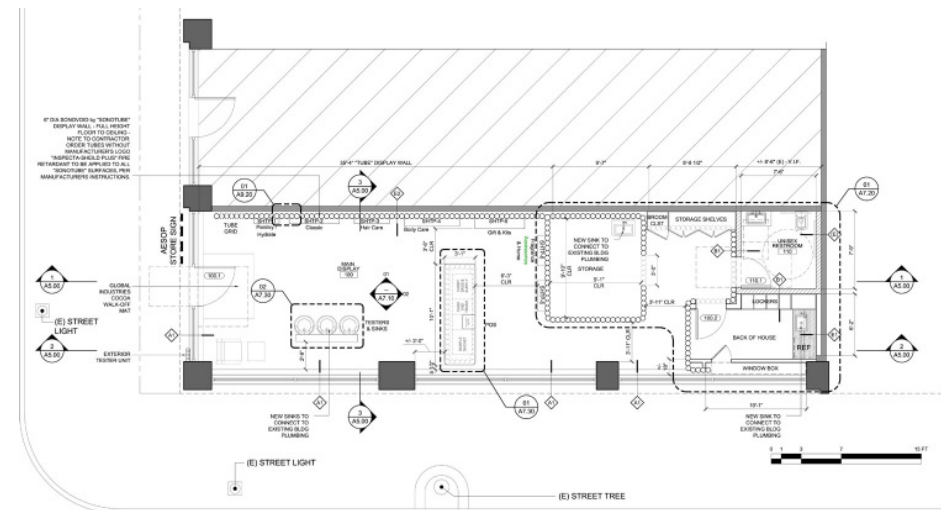

Figure 4.5. Aesop skincare store floor plan 2 (Aesop, 2016).

4.2 SKINCARE RETAIL ZONES

The investigation of the precedent studies including Jurlique, Dermalogica and Aesop (see page 70) and their grammatical functions guided the selection of the twelve skincare retail zones to be applied in the proposed Margaret Robert's skincare servicescape. These zones include the following:

1. Facade/Shopfront
2. Vertical Product Display
3. Floor Display
4. Product Testing Area
5. Skin Bar
6. Point of Sale
7. Waiting Area
8. Semi-Private Treatment Area
9. Private Treatment Area
10. Kitchenette
11. Ablution
12. Storage

Each of these twelve skincare retail zones and their function will be explained in further depth throughout this chapter.



Figure 4.6. Skincare Retail Zones (Author, 2016).

4.3 SKINCARE RETAIL TYPOLOGIES

Having analysed the retail precedent studies (see page 70) it is apparent that different retail typologies are formed based on the programmatical function included in each store. For instance, Aesop showcases a variety of different retail typologies; some of which are purely product orientated and some of which are both product and service orientated (Aesop, 2016). It is beneficial for a brand to develop a variety of retail typologies that can be applied in various different retail settings. For this reason, it was decided that the proposed skincare servicescape for Margaret Roberts would adopt a similar strategy that encompasses three different retail typologies that can be applied to suitable retail spaces. These typologies are as follows:

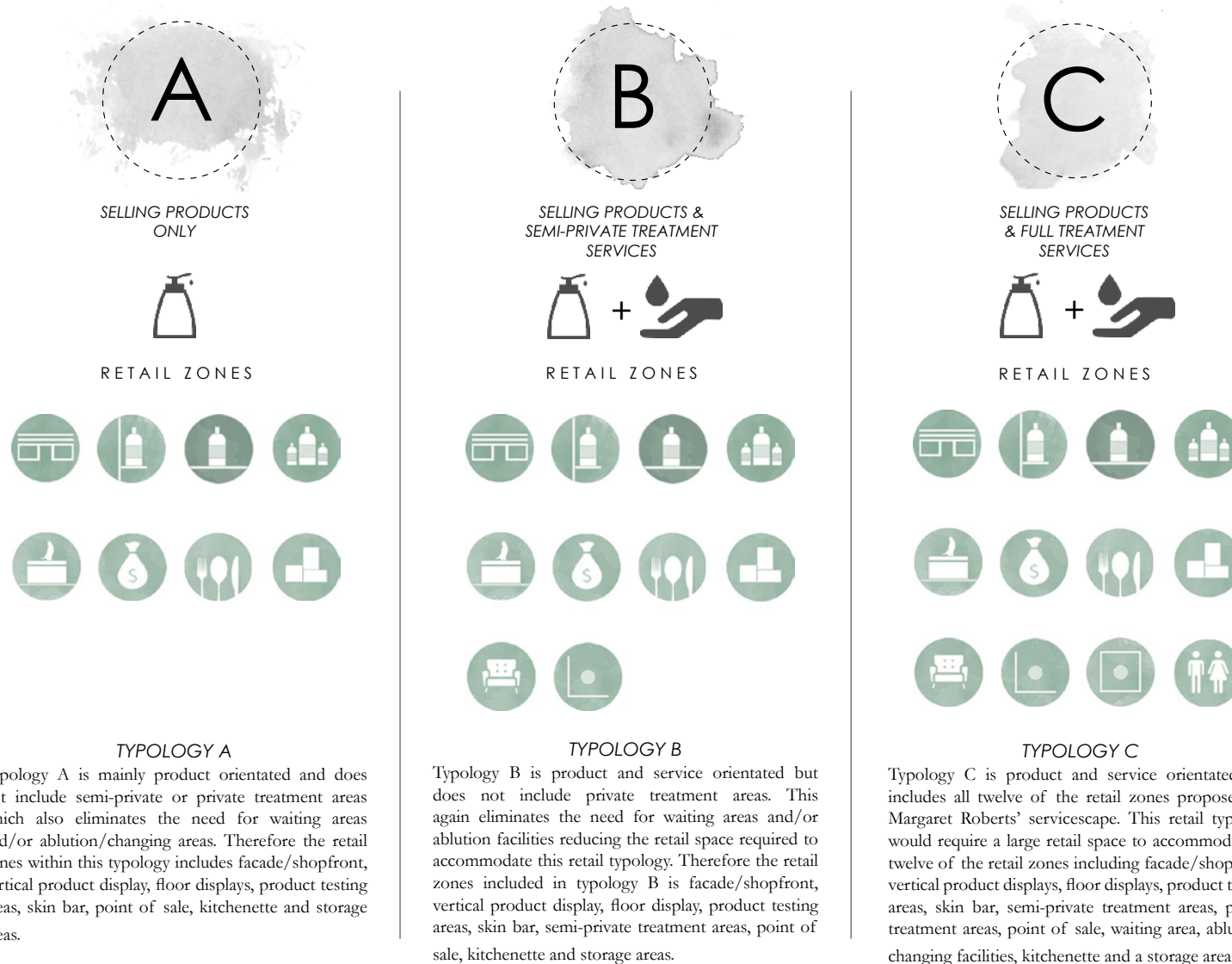

Figure 4.7. Skincare Retail Typologies (Author, 2016).

ZONE 01

Entrance / Facade



Zone 1 takes account the design of the shopfront/facade of the proposed skincare servicescape for Margaret Roberts, which includes the entrance doors, exterior signage and window displays. The main function of a shopfront is to communicate the essence of the brand and to give shoppers a glimpse of what is inside the store (Mesher, 2010:142). The design of the shopfront should carefully consider the threshold between the exterior and interior of the shop in order to create a comfortable transition that will attract shoppers to enter the store. Exterior signage and graphic communication is important for conveying the essence of the brand and should be incorporated into window displays and design of the entrance. Window displays must be designed to attract attention to the store and to give shoppers an insight into the lifestyle that the Margaret Roberts skincare brand is selling (Mesher, 2010:148). Graphic communication, lighting and display of products are therefore essential to the design of the window displays.

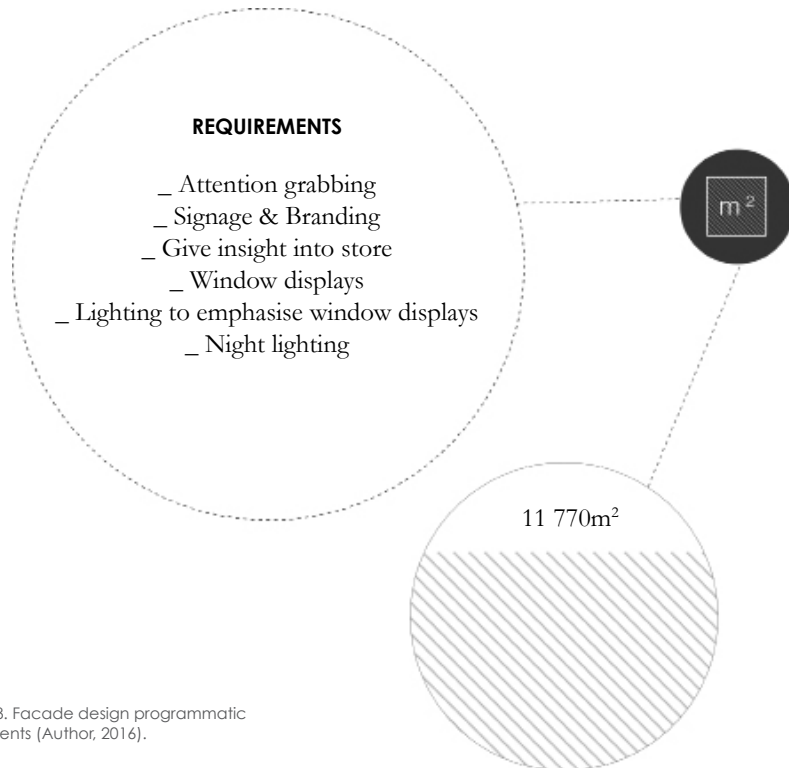

Figure 4.8. Facade design programmatic requirements (Author, 2016).

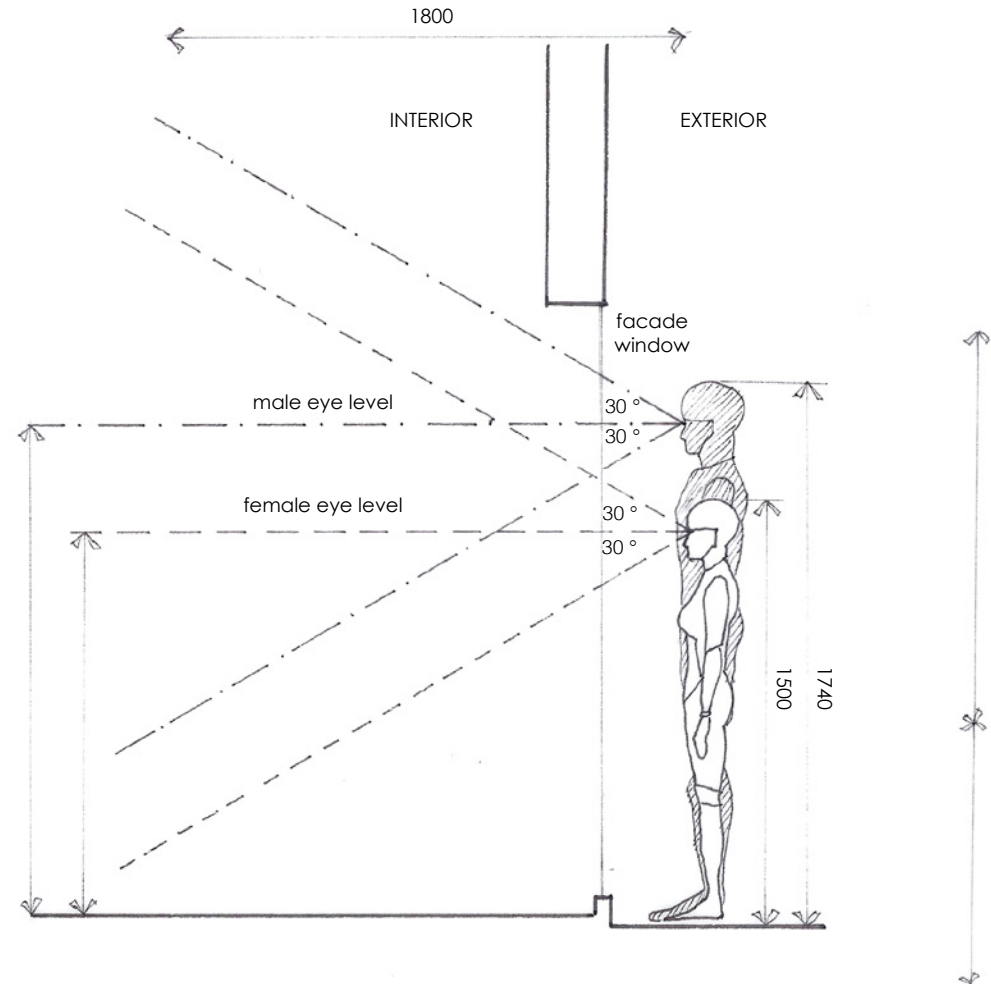

Figure 4.9. Facade design visual access (Author, 2016) compare with (Panero & Zelnik, 1979).



**PRECEDENT STUDY
[AESOP]**

Aesop cleverly designs the facade of their stores as an opportunity to experience the product and/or showcase the materiality of the interior environment.

The facades are simple in design, yet effective in communicating the core identity of each individual Aesop store.

Product testers are imbedded within the facade and act as a means for consumers to interact with the product even before entering the store.



Figure 4.10. Facade Design precedent study
(Author, 2016; Aesop, 2016).

ZONE 02

Vertical Product Display



Zone 2 includes the design of vertical product display units, which are mounted onto vertical surfaces such as walls and partitioning. These displays will serve the purpose of presenting the Margaret Roberts skincare product to the shoppers in a creative and interesting manner that also takes the brand experience into consideration (Mesher, 2010:127). The vertical displays allow maximization of product display without using a lot of floor space and can also become multifunctional by including storage space within the display. Lighting is crucial to the design of the display and should be used to highlight specific areas to create attraction points. It is also important to consider the visual merchandising layout of products on vertical surfaces since this influences the accessibility of the products on display. According to Ebster (2015), vertical displays can be divided into four different zones including the following;

1) Stretch Level (above 1800mm)

The stretch level is not ideal for product placement since it is hard to reach for most people and takes physical effort to retrieve products on this level. This level and above is better utilized for product information displays (Ebster, 2015).

2) Eye Level (1200-1600mm)

This level is most visually accessible (to adults) and receives 35% more attention than other display areas, therefore selling more products compared to other levels (Ebster, 2015).

3) Grab Level (700-1700mm)

The grab is not as visually accessible as the Eye Level, however it is still comfortable for shoppers to grab products from this level. This level is second best to the Eye level for selling products (Ebster, 2015).

4) Stoop Level (below 900mm)

The stoop level is not within the average shopper's field of view from a standing position and is a very uncomfortable height to grab products from. This level is better suited for product storage (Ebster, 2015).

"Display areas are at the heart of a retail store. Display is the mechanism that presents the merchandise to the shopper in its most favourable light and that permits the shopper to evaluate and select products for purchase."

William Green (Green, 1991)

REQUIREMENTS

- _ Maximise displaying space
- _ Signage & branding incorporated into display
- _ Educational displays
- _ Lighting to highlight products
- _ Storage within display

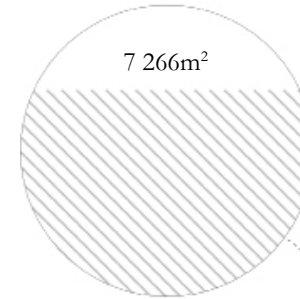

Figure 4.11. Vertical display programmatic requirements (Author, 2016) compare with (Panero & Zelnik, 1979).

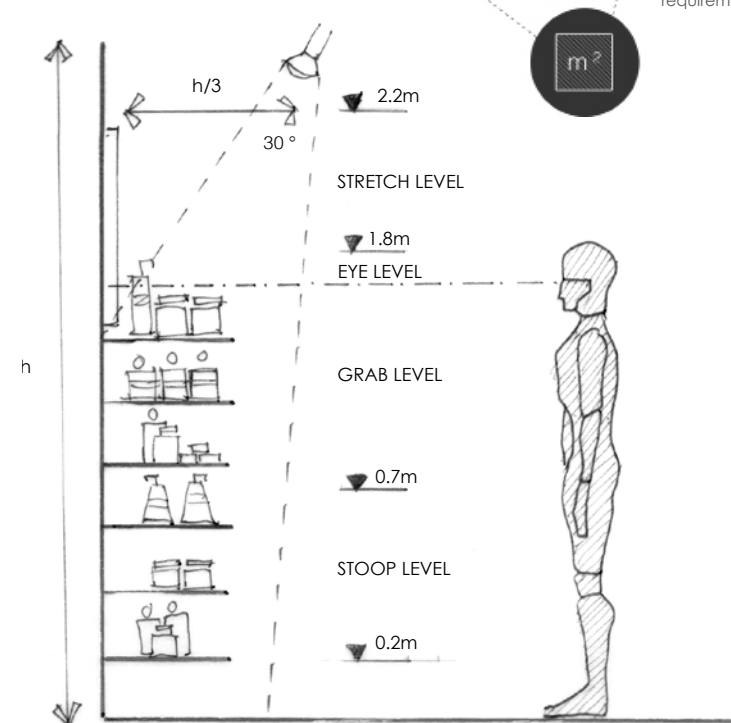

Figure 4.12. Vertical display ergonomic requirements (Author, 2016) compare with (Panero & Zelnik, 1974).

PRECEDENT STUDY [ORIGINS]

Origins aims to provide an interactive retail experience for consumers.

The retail experience educates consumers about the natural healing properties of plants and how these plants are incorporated into the Origins skincare products.



PRECEDENT STUDY [AESOP]

Aesop designs creative yet functional displays that are individualised for each different store.

Each design tells a story and aims to draw attention to the products on display.

Minimal products are displayed in an orderly fashion to create a sense of luxury.

Figure 4.13. Vertical display precedent study (Author, 2016; Aesop, 2016).

ZONE 03

Floor Display



Zone 3 is designated to the design of display units that will be showcased on the floor area of the store. The advantage of incorporating floor display units into the design scheme is to maximize the use of the floor space and to create variety in the type of product displays. Floor displays differ from vertical product displays in the sense that they can be accessed from more than one side and that they are often movable structures that can be rearranged within the store. When designing floor displays for Margaret Robert's skincare servicescape, it is important to consider that the merchandise is small and will need to be raised to an appropriate height for shoppers to have visual access to the products. Signage and lighting is also plays a key role in the design of the floor displays, to ensure visual accessibility.

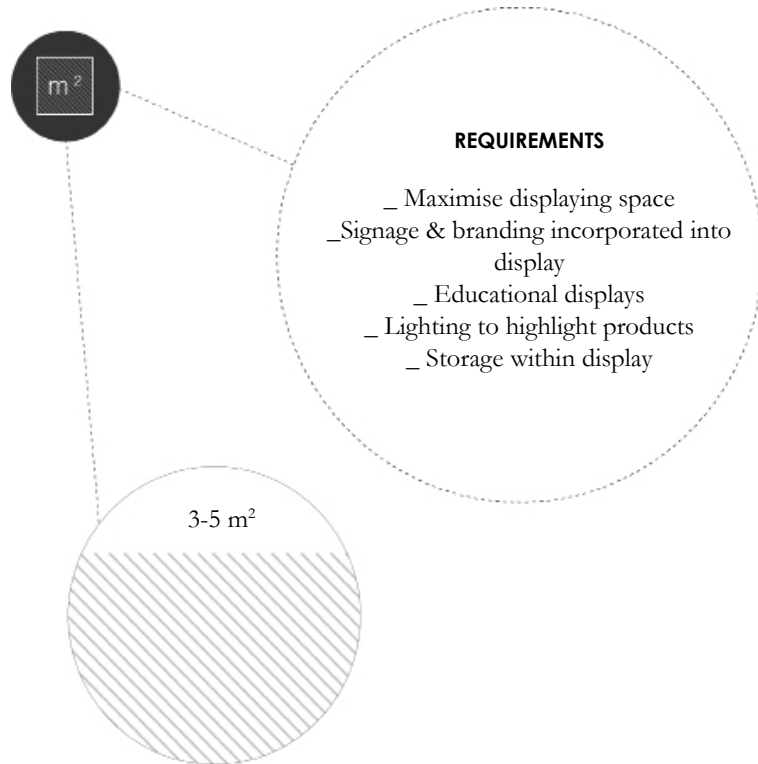

Figure 4.14. Floor display programmatic requirements (Author, 2016).

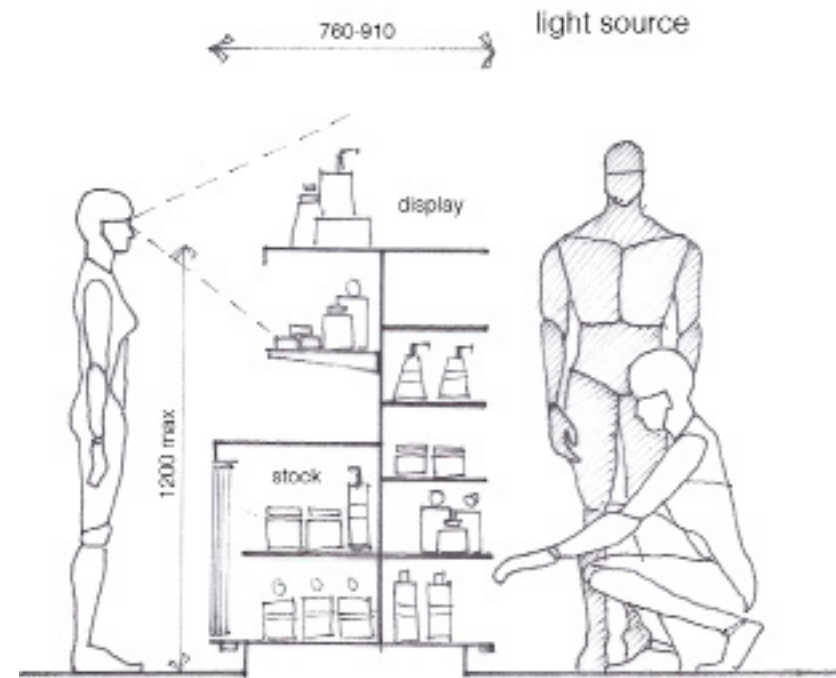

Figure 4.15. Floor display ergonomic requirements (Author, 2016) compare with (Panero & Zelnik, 1979).

ZONE 04

Product Testing



As seen in the precedent studies of Aesop and Jurlique (see page 70) the inclusion of a product testing area within a skincare store allows clients to interact with the products and can have an influence on purchasing decisions. This zone will consist of a designated area within the store that includes access to water to make provision for a sink, allowing clients to test and rinse off any products if needed. It would be favourable for this zone to be staffed with a skincare professional that would give advice to clients about the type of products that would be best suited for their skin type.

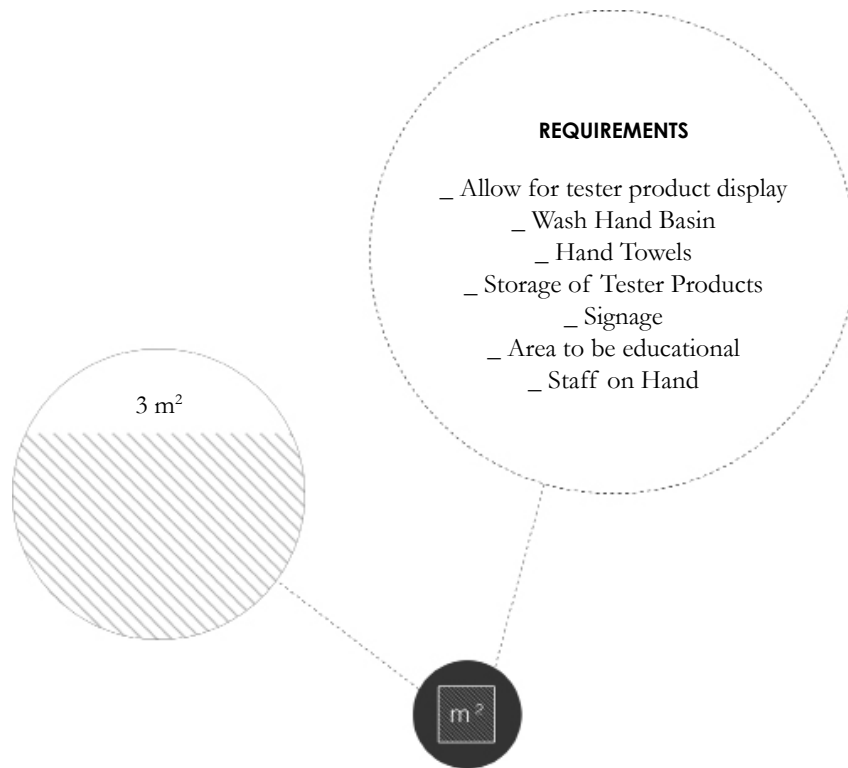

Figure 4.18. Product testing programmatic requirements(Author, 2016).

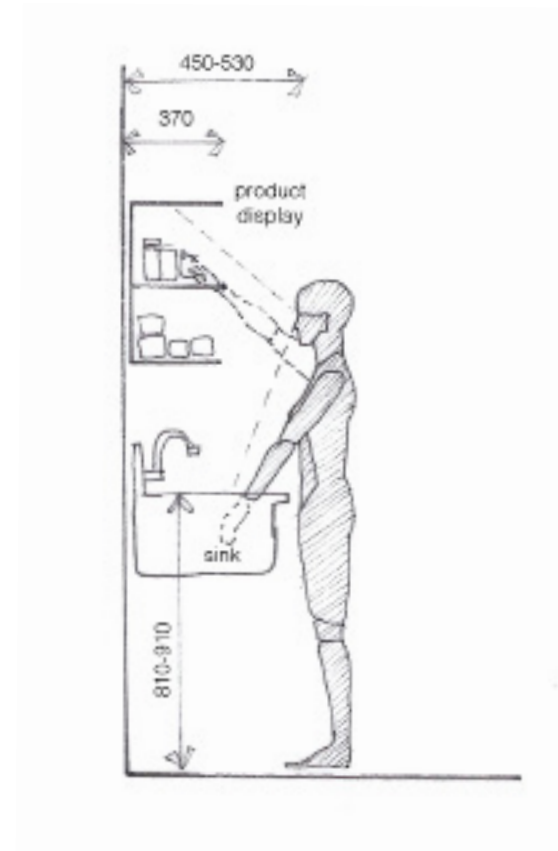

Figure 4.19. Product testing ergonomics requirements (Author, 2016) compare with (Panero & Zelnik, 1979).

PRECEDENT STUDY [Aesop]

Aesop provides a product testing area in each of their stores. This allows customers to interact with the product in the hope of persuading them to make a purchase.

Access to water is essential for customers to be able to wash of the product if necessary.

Aesop staff members will guide customers towards the product that is best suitable for their skin type. These products will then be recommended and tested on the customers at these product testing zones.

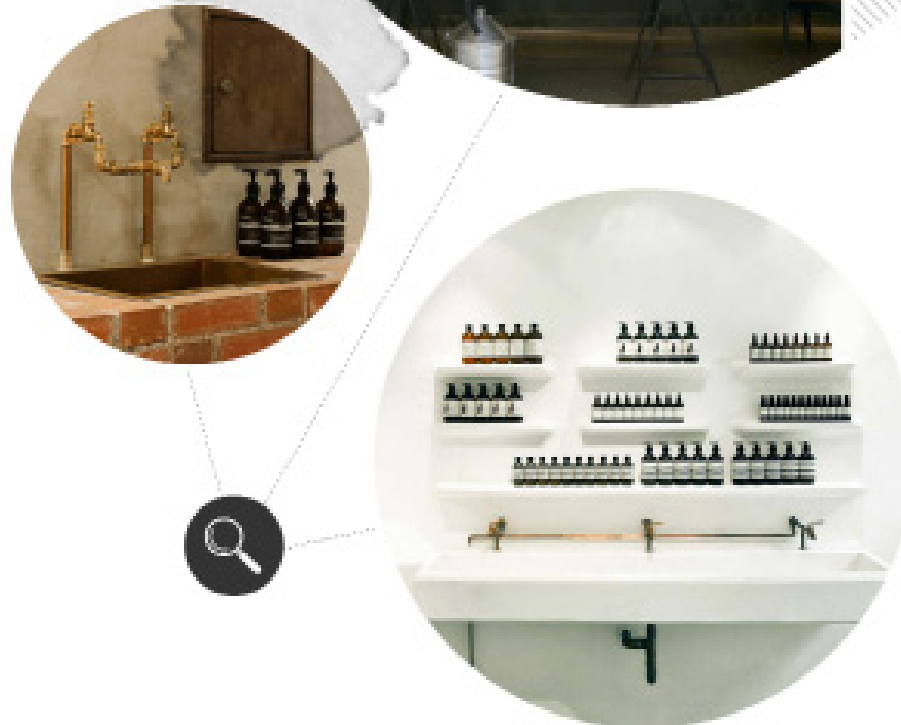

Figure 4.20. Aesop product testing area
(Author, 2016; Aesop, 2016).

ZONE 05

Skin Bar



The skin bar is a service and product-orientated zone that will allow clients to sit down and consult with informed staff members about their skincare concerns. The staff members will assess the client's skin type and advise them about the skincare range that will benefit said client. This zone therefore requires a service counter, areas for product and information display, storage space and access to running water. Specialized equipment may be used in this zone and should be considered in the design process. Lighting, especially task lighting is essential in this zone and should be carefully considered in order to allow staff members to successfully carry out skin type assessments on clients.

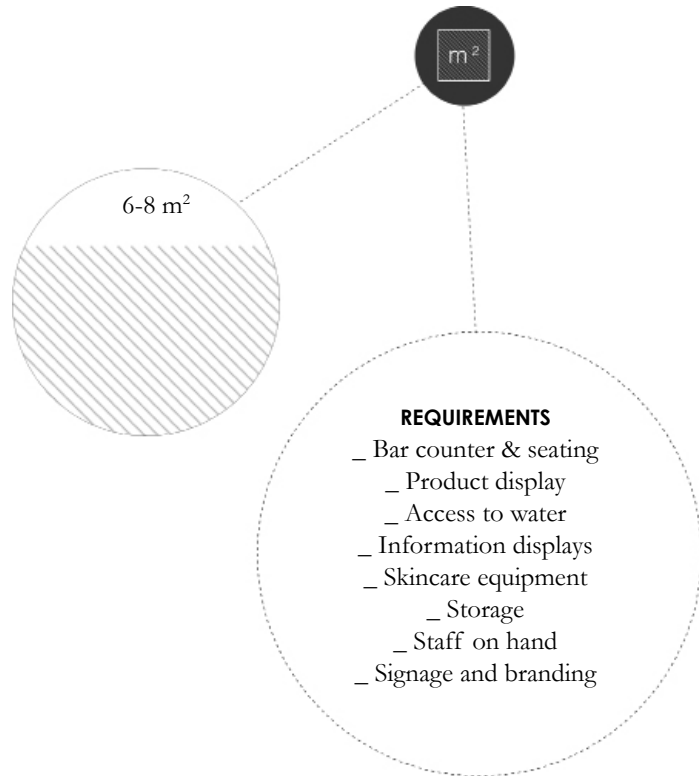

Figure 4.21. Service counter programmatic requirements (Author, 2016).

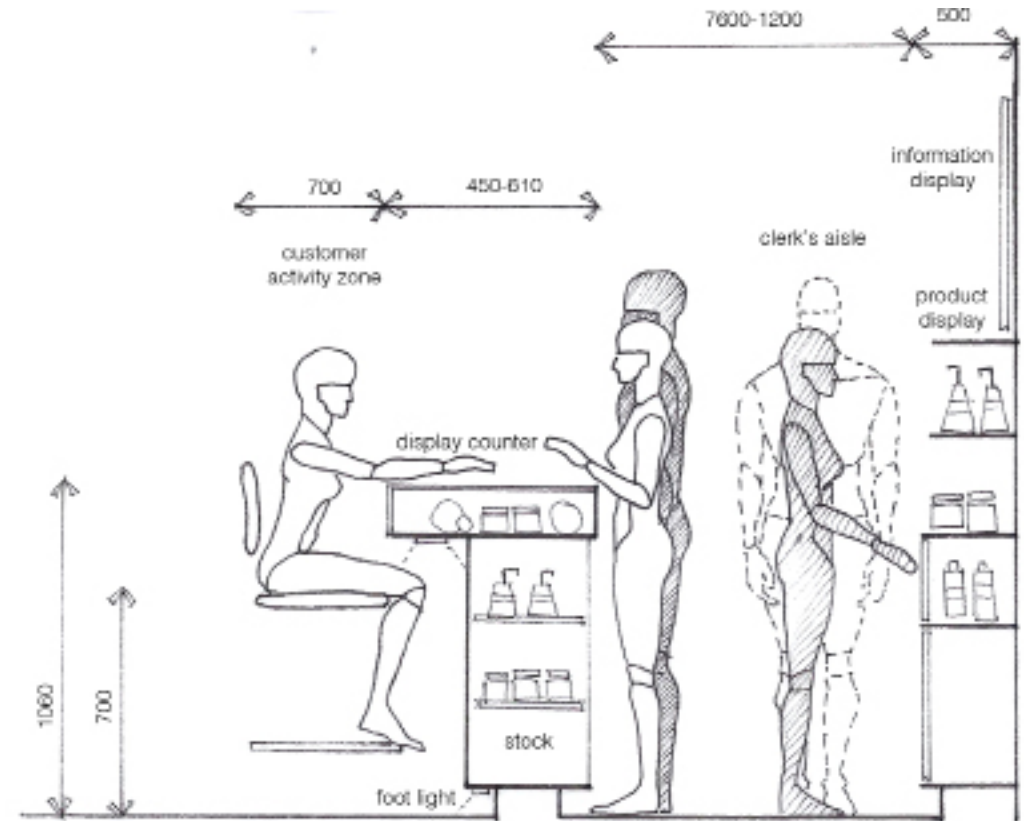

Figure 4.22. Service counter ergonomics (Author, 2016) compare with (Panero & Zelnik, 1979).

PRECEDENT STUDY [DERMALOGICA]

Dermalogica adds value to their stores by providing facial mapping and skin analysis services at their 'skin bars'. Through this service, clients receive individualised skincare recommendations.

This area includes a bar-seating area equip with small standing facial mirrors and equipment for testing the different skin types.



PRECEDENT STUDY [Aesop]

The skincare consultation areas seen in Aesop stores are much more simplified and is simply a designated area for staff members to sit down with customers and provide them with individualised skincare recommendations.

Figure 4.23. Aesop and Dermalogica Skin Bar
(Author, 2016; Aesop, 2016; Dermalogica, 2016).

ZONE 06

Point of Sale / Reception



Zone 6 will serve as both a point of sale and reception area that marks the end of the shopping journey and the beginning of the journey to the service areas (see Zone 7, 8 and 9). The point of sale/reception area is a very important brand touchpoint, which should be used to create a final and lasting impression on shoppers (Mesher, 2010: 133). It is also important for the point of sale/reception area to be emphasized through signage and lighting to guide shoppers to this area where they will complete their purchase.

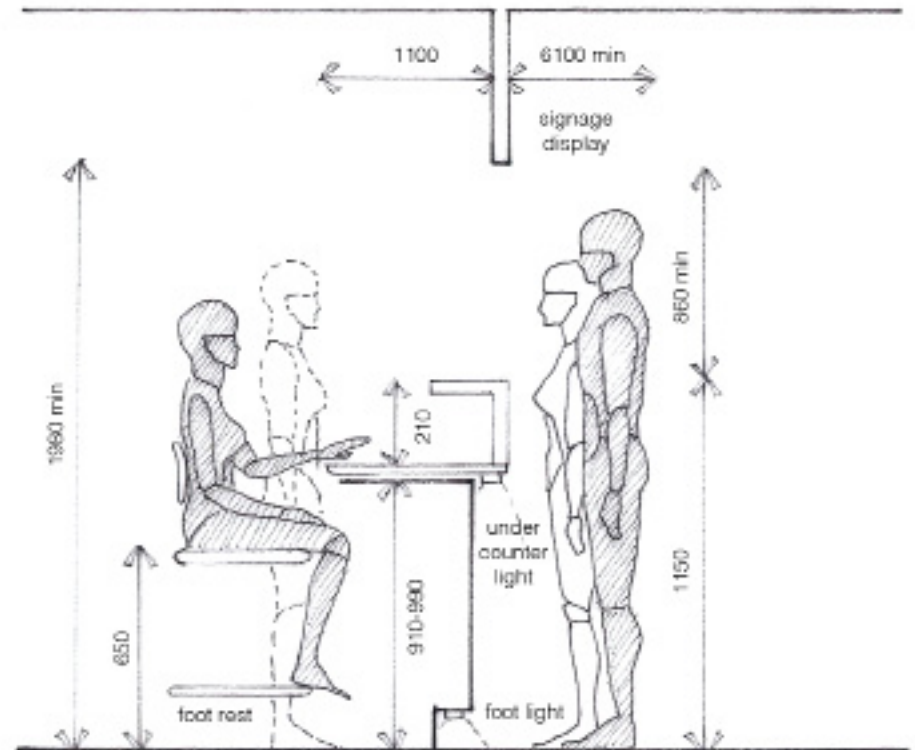
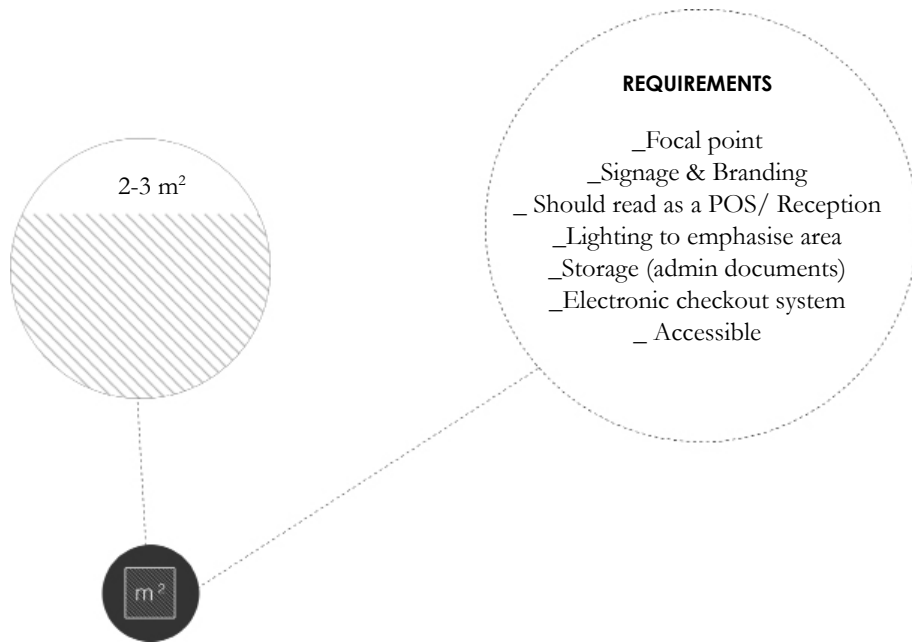

Figure 4.24. Reception / point of sale programmatic (Author, 2016)

Figure 4.25. Reception / point of sale ergonomics (Author, 2016) compare with (Panero & Zelnik, 1979).

**PRECEDENT STUDY
[Aesop]**

RIGHT >>>

These spa reception counters are beautiful and elegant in their design. The counters are not cluttered with additional product display creating a sense of luxury about the space.

The store name is often incorporated into the backdrop of the reception counter to reinforce the brand that is represented.

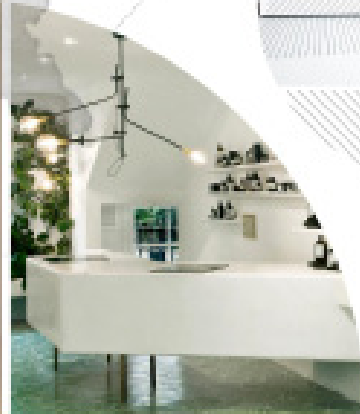

**PRECEDENT STUDY
[Aesop]**

<<< LEFT

The Aesop point of sales/reception counters are very minimalistic in design. Touch screen electronic sales systems are imbedded within the counter to create a very clean and slick look. Pendant lighting is used to draw attention to the counter and to highlight it as a point of interest.

Figure 4.26. Point of sale precedent study (Author, 2016; Aesop, 2016).

ZONE 07

Waiting Area



Zone 7 is appointed to the waiting area, which will provide a tranquil and relaxing space for clients to sit and wait before undergoing treatment (see Zone 8 & 9). This zone acts as the transition zone between the retail space and service/treatments areas and should therefore be designed to calm and relax clients in order for them to feel comfortable to undergo private skincare treatments. The functional requirements of this space include seating, coffee table(s) and should also include product displays to keep clients occupied during the waiting period.

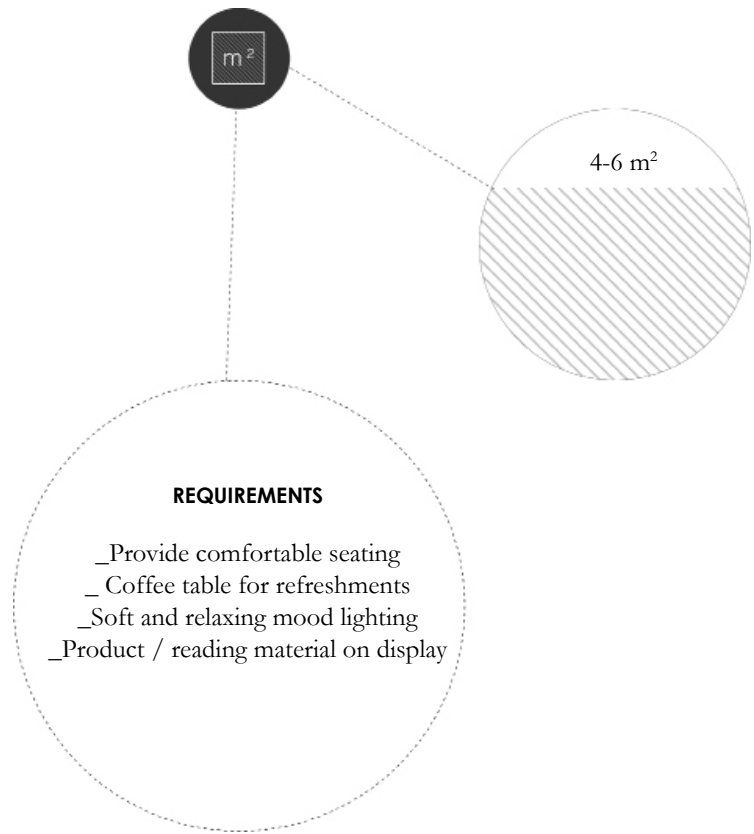

Figure 4.27. Waiting area programmatic requirements (Author, 2016).

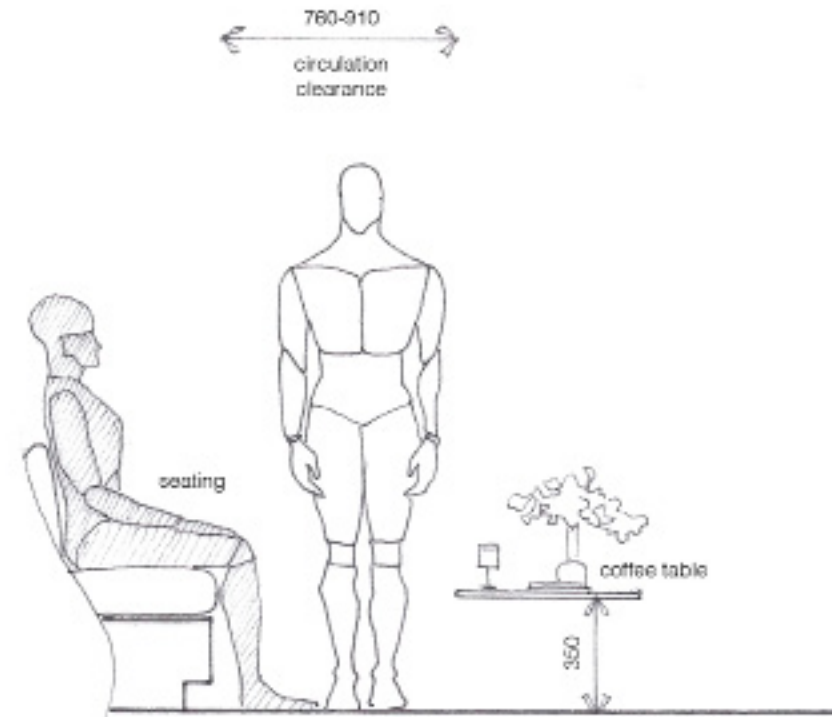

Figure 4.28. Waiting area ergonomic requirements (Author, 2016) compare with (Panero & Zelnik, 1979).

PRECEDENT STUDY
Waiting Areas

These waiting areas provide comfortable seating as well as a coffee table/ small side tables for serving of refreshments.

Products and/or reading material related to the store can be provided to keep clients occupied while waiting.

This area should provide a comfortable and relaxing atmosphere to allow clients to unwind before their treatments.

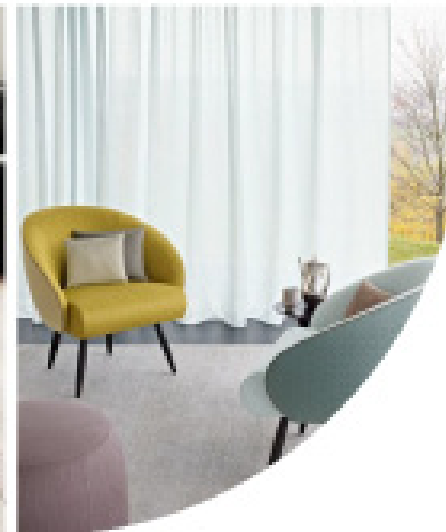

Figure 4.29. Waiting area precedent study
(Author, 2016; Architonic, 2013).

ZONE 08

Semi-Private Treatment Area



Zone 8 is purely a service orientated zone that is designated to the design of semi-private treatment areas, which is similar to that of Dermalogica's MicroZone (see page..). The treatments offered in this zone include face, hand and foot skincare treatments, which does not require clients to disrobe. Therefore, semi-private designated treatment areas will suffice. Zone 8 will need to accommodate for therapy chairs, access to water and product storage space. A tranquil and relaxing atmosphere should be created in this zone to allow clients to enjoy the full healing and rejuvenating experience.

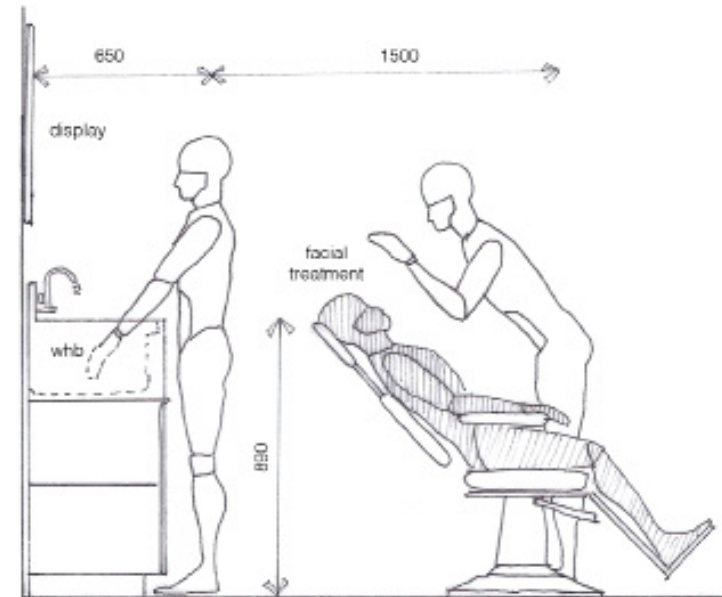
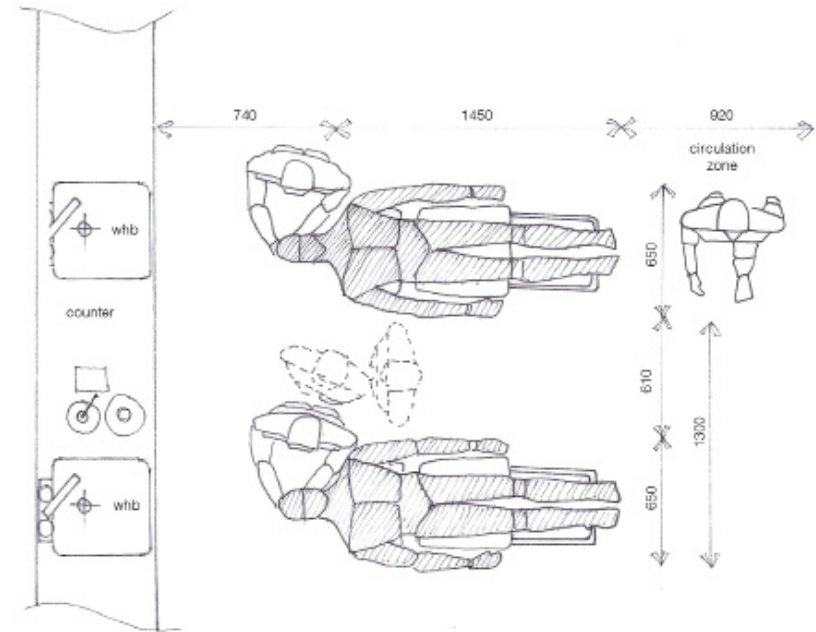
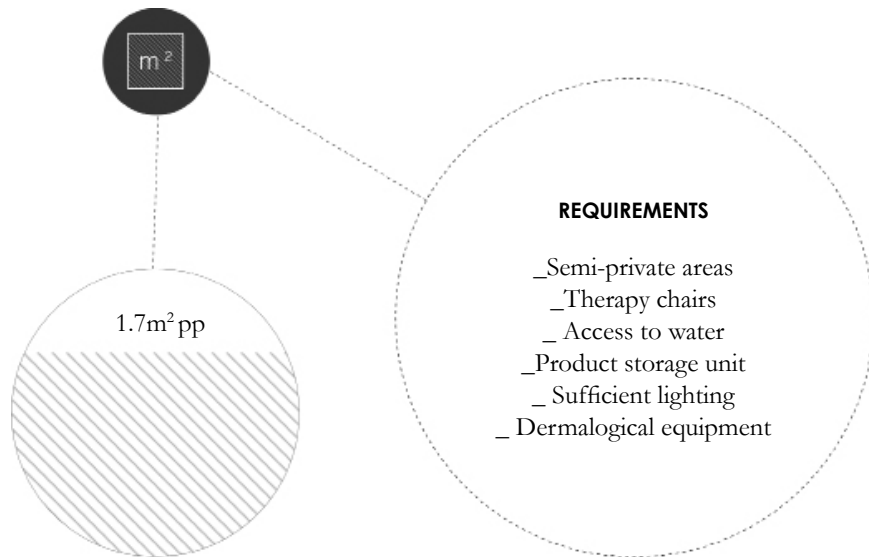

Figure 4.30. Treatment area programmatic requirements (Author, 2016).

Figure 4.31. Treatment area ergonomic requirements (Author, 2016) compare with (Panero & Zelnik, 1979).

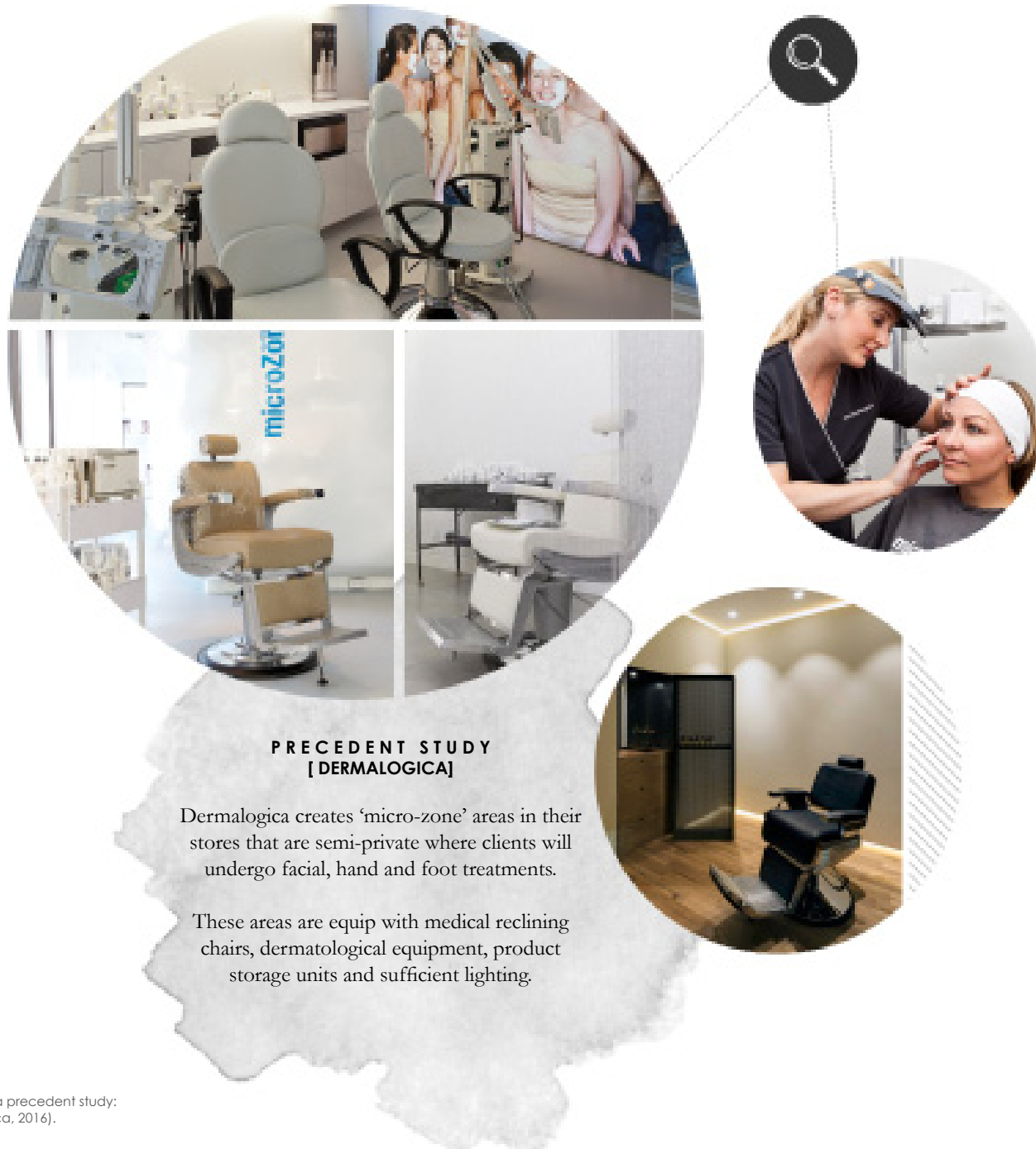

Figure 4.32. Semi-Private treatment area precedent study:
Dermalogica (Author, 2016; Dermalogica, 2016).

ZONE 09

Private Treatment Area



Zone 9, much like Zone 8 is a service orientated zone, but differs in the type of skincare treatments offered. Zone 9 will offer services similar to that of Zone 8 but will also include full-body skincare treatments which may require clients to disrobe. For this reason it is essential for the treatment areas to be fully private to create an environment which will allow clients to be comfortable enough to disrobe if necessary. The design of Zone 9 should accommodate for treatment beds, storage of products and access to water. Acoustics, ventilation and temperature control in this zone is imperative to create a space that is comfortable, relaxing and conducive to healing and rejuvenation.

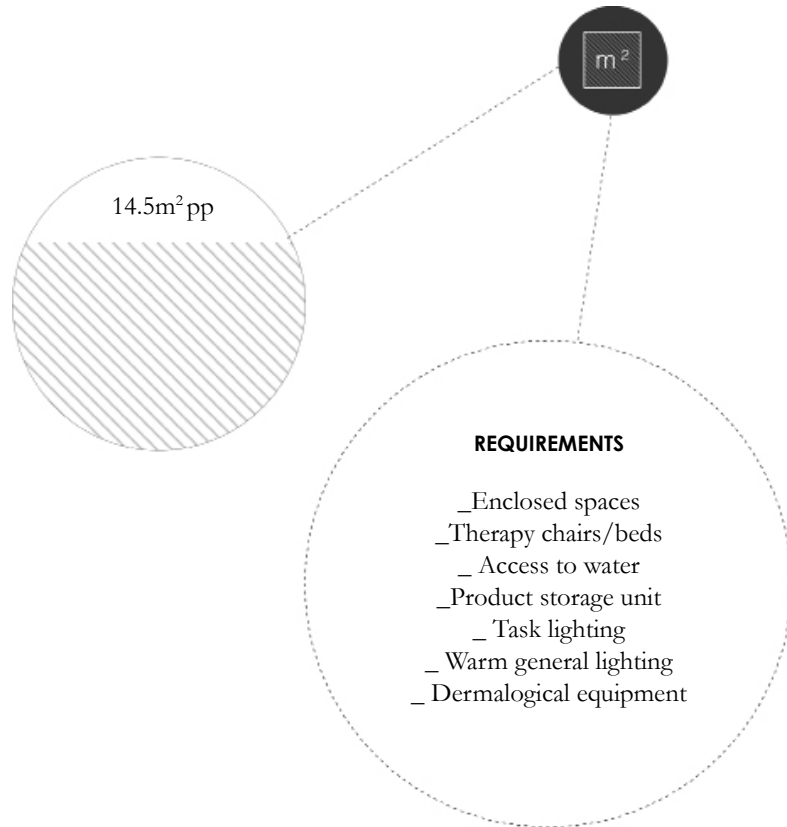

Figure 4.33. Private treatment area programmatic requirements (Author, 2016)

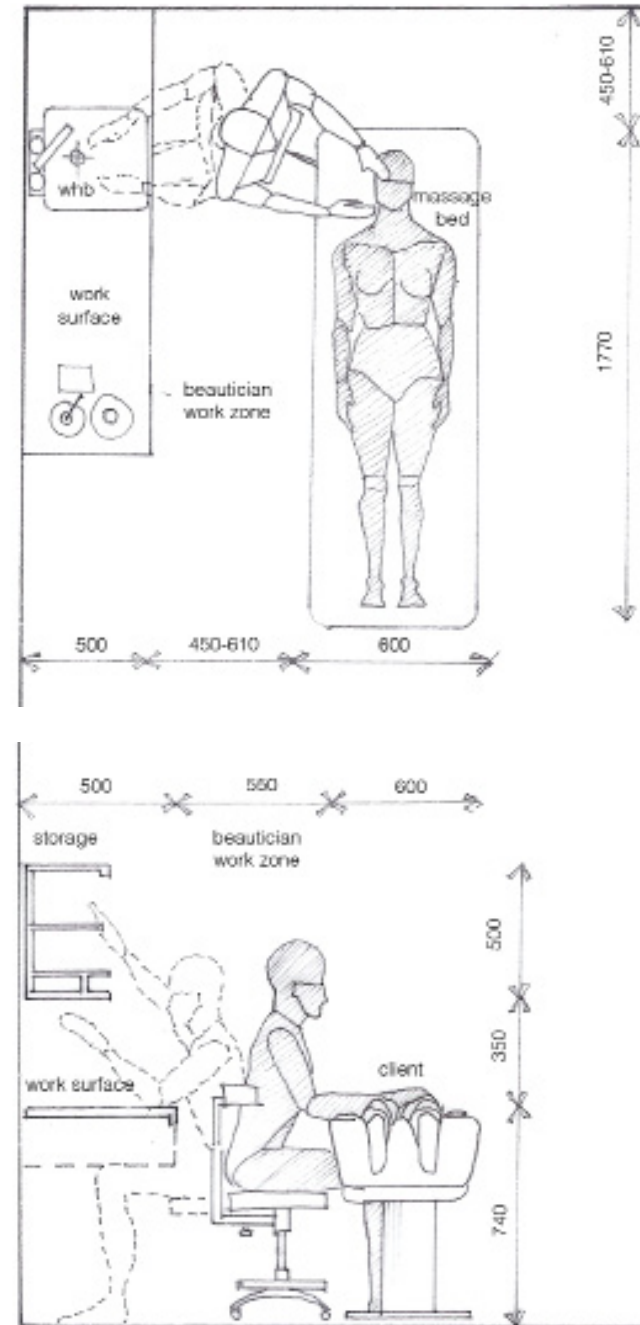

Figure 4.34. Private treatment area ergonomic requirements (Author, 2016) compare with (Panero & Zelnik, 1979).

PRECEDENT STUDY [DERMALOGICA]

The use of stark white furniture with accents of grey, bright white lighting and medical equipment makes the Dermalogica treatment rooms very clinical in nature.

This is in keeping with the 'dermatological' associations with the brand.



PRECEDENT STUDY [Aesop]

Aesop private treatment areas showcase the use of warm lighting, soft bedding and natural materials such as cotton and wood to create a comfortable and relaxing environment.

This is more in line with the type of environment that will be created in the Margaret Robert's treatment rooms.

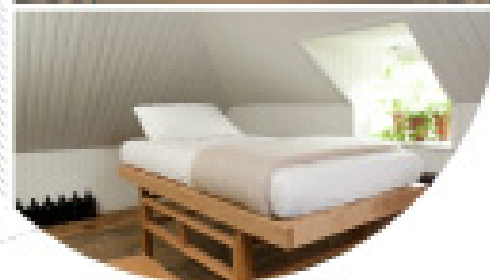
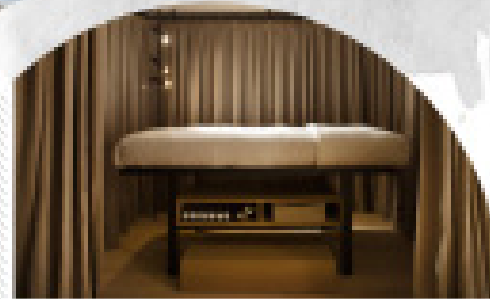

Figure 4.35. Private treatment area precedent study: Dermalogica & Aesop (Author, 2016; Aesop, 2016; Dermalogica, 2016).

ZONE 10

Kitchenette



Zone 10 is designated to the design of the kitchenette, which is a zone that is only accessible to staff members. The function of the kitchenette is to provide staff members with a breakaway space in which they can have a coffee/tea break and prepare their lunch. This space should also include a laundry area fitted with a washing machine and tumble dryer for cleaning of linen used in the treatment areas. Additionally, the kitchenette will be used for the purpose of preparing refreshments for clients who are sitting in the Waiting Area (Zone 7). The kitchenette should therefore be equipped with a sink, refrigerator, microwave, toaster, kettle, dry storage space for crockery and should have access to running water.

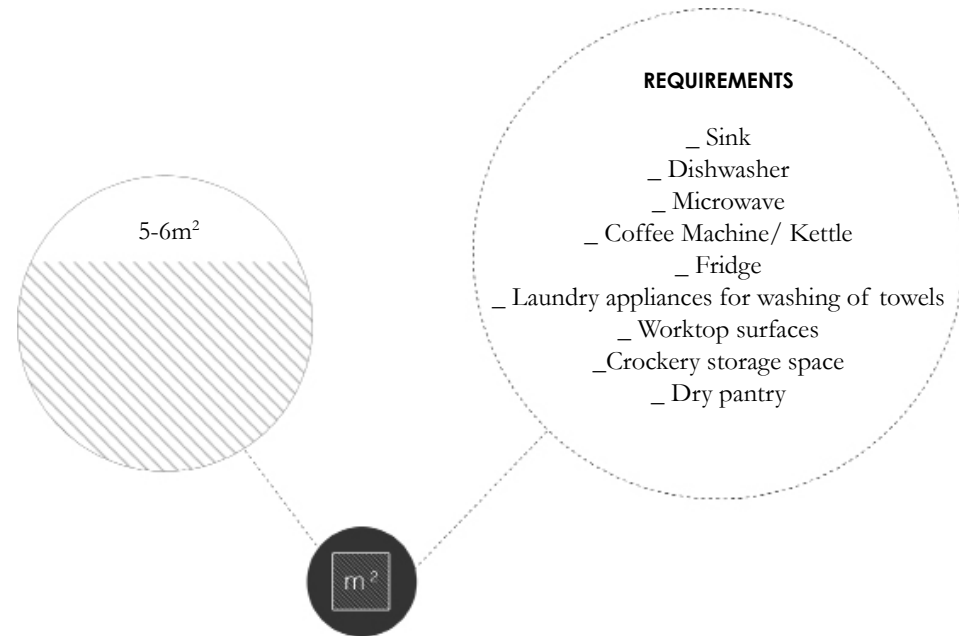
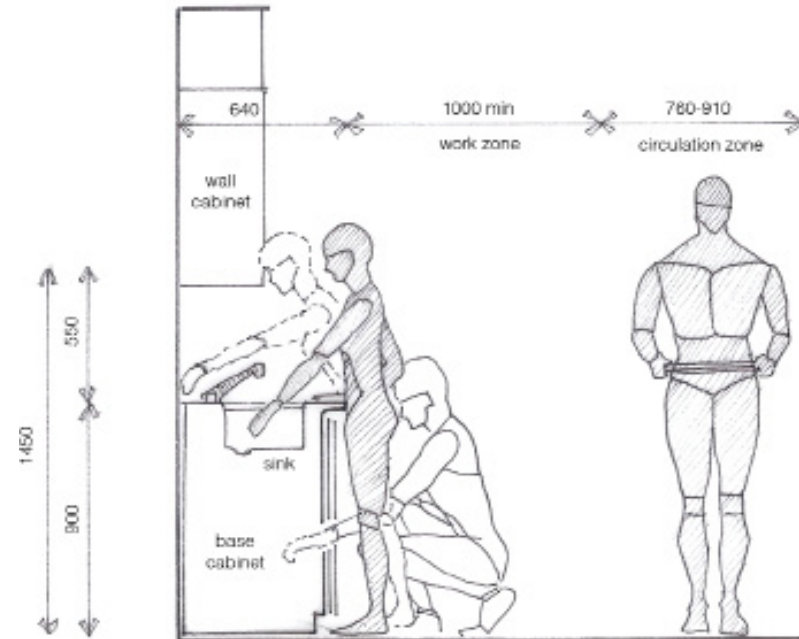
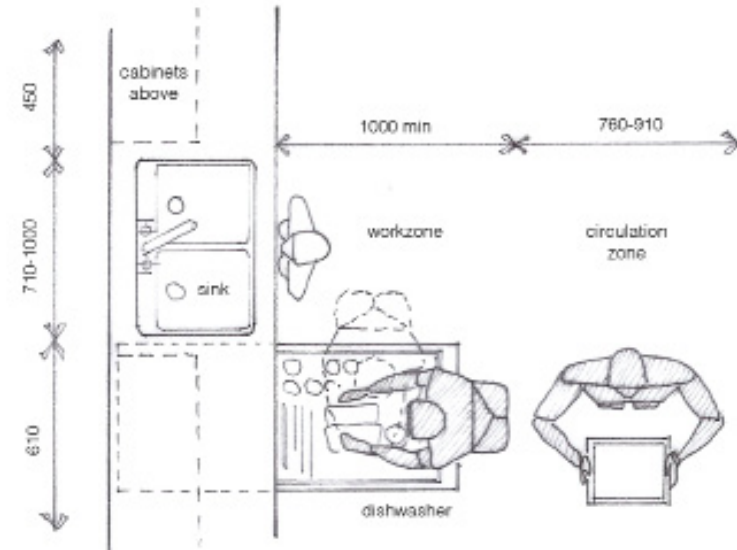

Figure 4.36. Kitchenette programmatic requirements (Author, 2016).

Figure 4.37. Kitchenette ergonomic requirements (Author, 2016) compare with (Panero & Zelnik, 1979).

PRECEDENT STUDY
[Kitchenette Designs]

The combination of white surfaces and wooden finishes makes these kitchen spaces look fresh and invigorating.

Innovative vertical storage systems can be used to maximise the space in a small kitchen.



Figure 4.38. Kitchenette precedent study (Author, 2016; Howarth, 2015).

ZONE 11

Ablution



Ablution facilities equipped with toilets, changing and shower areas need to be provided in the programmatic scheme since some of the treatments may involve full body scrubs and massages with aromatherapy oils. Clients will therefore need to have access to a shower to rinse off before leaving the Margaret Robert's store. An accessible toilet and shower facility should also be considered as part of the scheme of Zone 11.

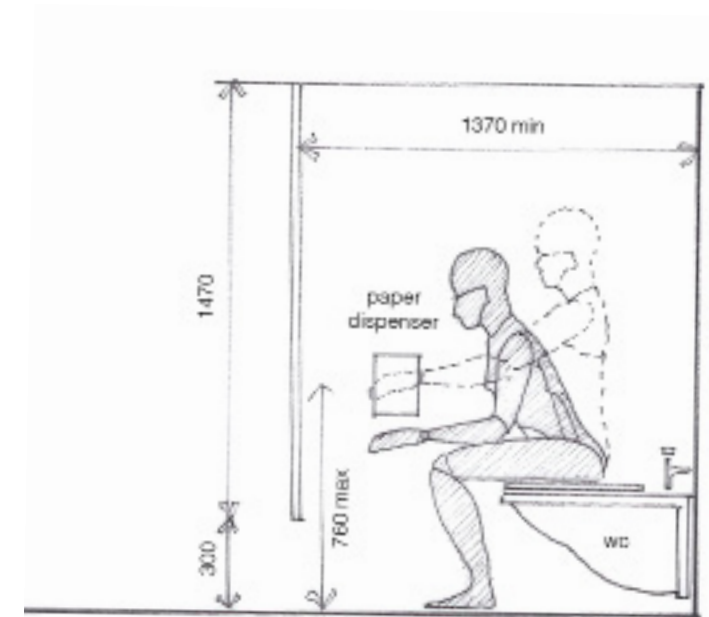
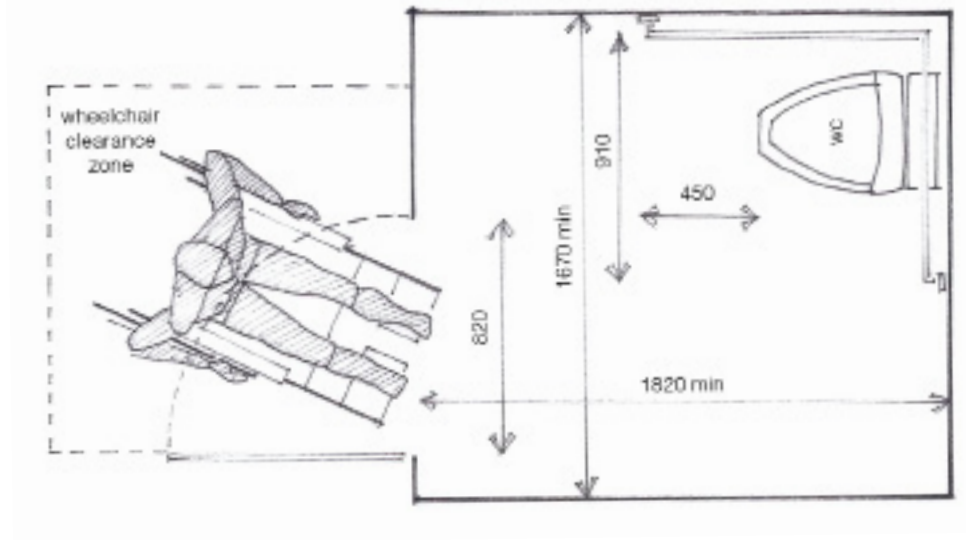
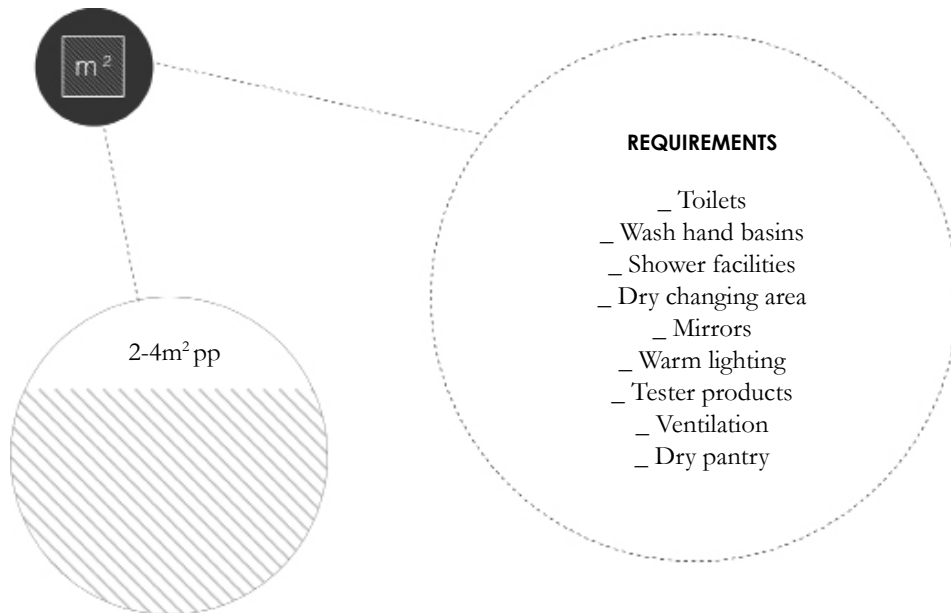

Figure 4.39. Accessible toilet programmatic requirements (Author, 2016).

Figure 4.40. Accessible toilet ergonomic requirements (Author, 2016) compare with (Panero & Zelnik, 1979).

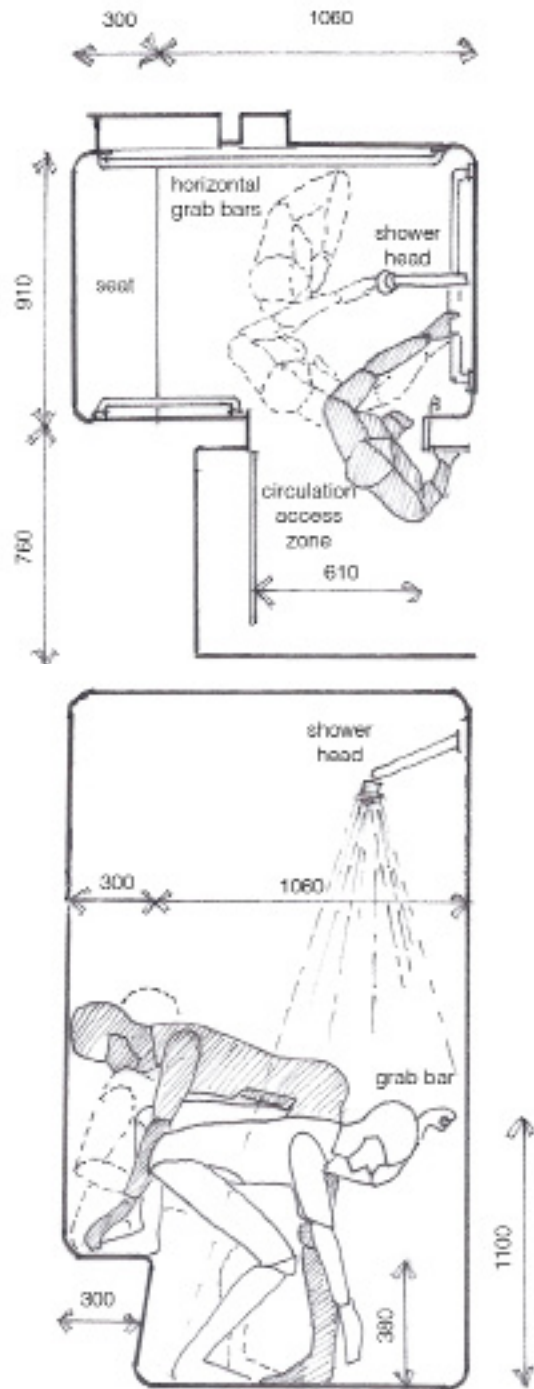

Figure 4.41. Shower facilities ergonomic requirements (Author, 2016) compare with (Panero & Zelnik, 1979).



**PRECEDENT STUDY
[Public Bathroom/Changing Room]**

The stark white and wooden finishes in these bathrooms creates an area that appears sanitary yet warm and inviting.

A hint of green in the form of pot plants makes these bathroom spaces in tune with nature, rendering it to be a relaxing and rejuvenating space to be in.



Figure 4.42. Ablution facilities precedent study (Author, 2016; Howarth, 2015).

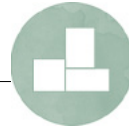

ZONE 12

Storage

Zone 12 is designated for storage of equipment and extra stock of products that may be required in the store. This zone should allow access to the service corridor connected to the retail space. It is not necessary to consider the atmosphere or experiential qualities of this space since it is only accessible to staff members and does not form part of the retail space as a whole.

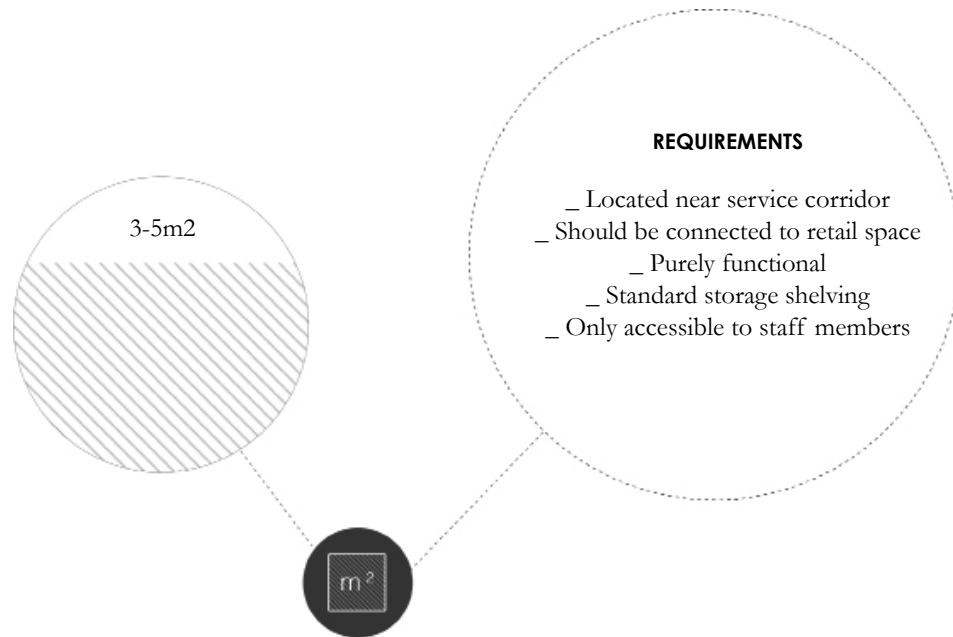

Figure 4.43. Storage area functional requirements (Author, 2016).

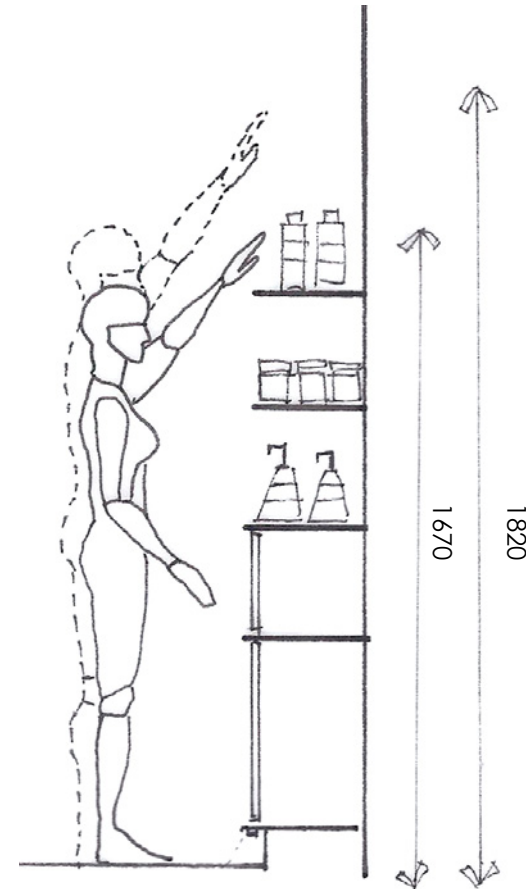

Figure 4.44. Storage area ergonomic requirements (Author, 2016) compare with (Panero & Zelnik, 1979).

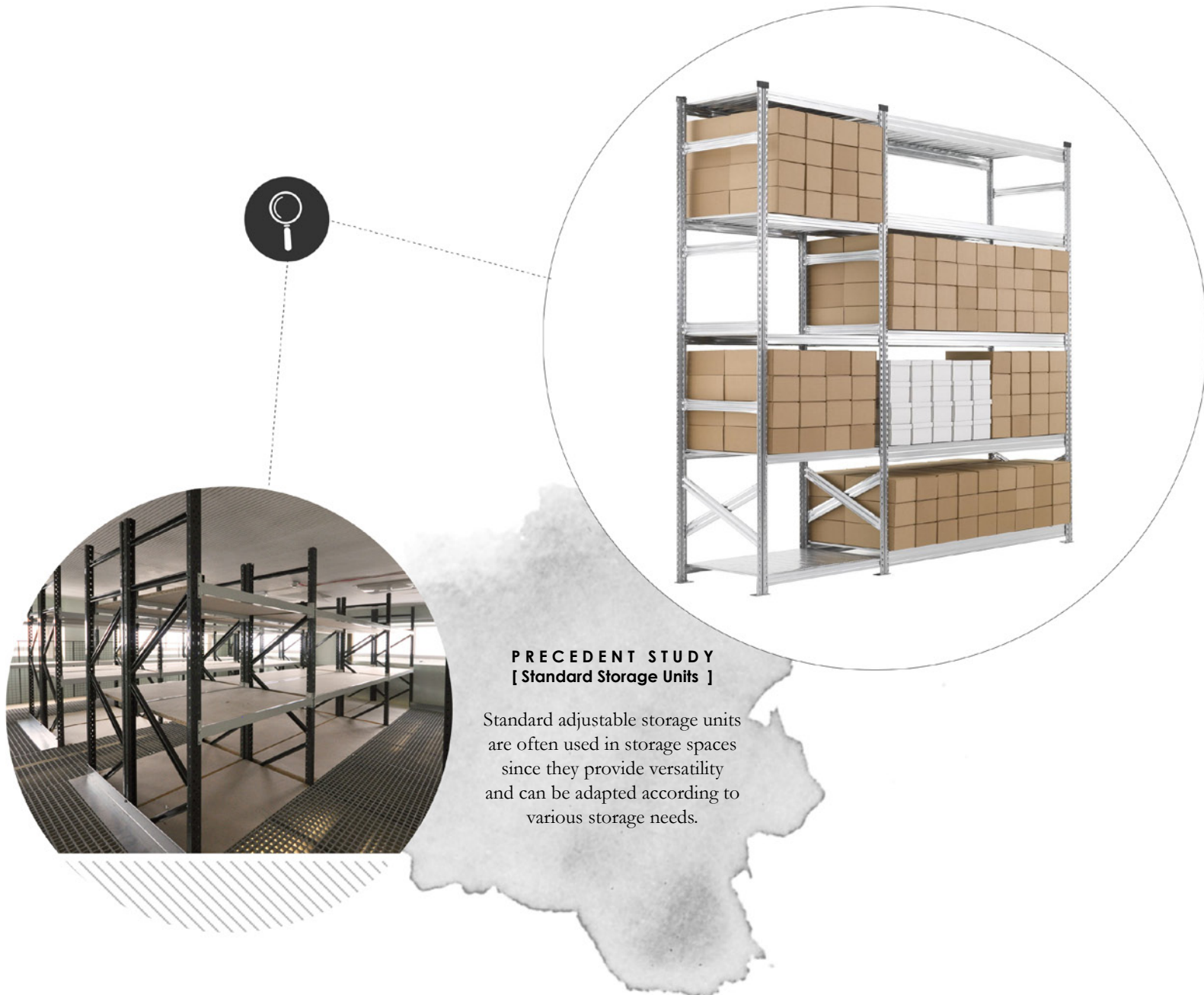

Figure 4.45. Examples of standard storage shelving
(Author, 2016; Bunnings, 2016).



CONCEPTUAL DEVELOPMENT

DISCOVER

This chapter aims to apply the theories of branding, Biomimicry and Biophilic design (as discussed in Chapter 2) towards the development of a design concept. Kapferers' Brand Identity Prism (2012) is used as a guideline for creating a new proposed brand identity for Margaret Roberts' skincare servicescape. The application of Biomimicry principles and theories is investigated towards developing a sustainable retail design solution. Lastly, Biophilic and experiential design theories are combined to construct an experiential design concept.

05

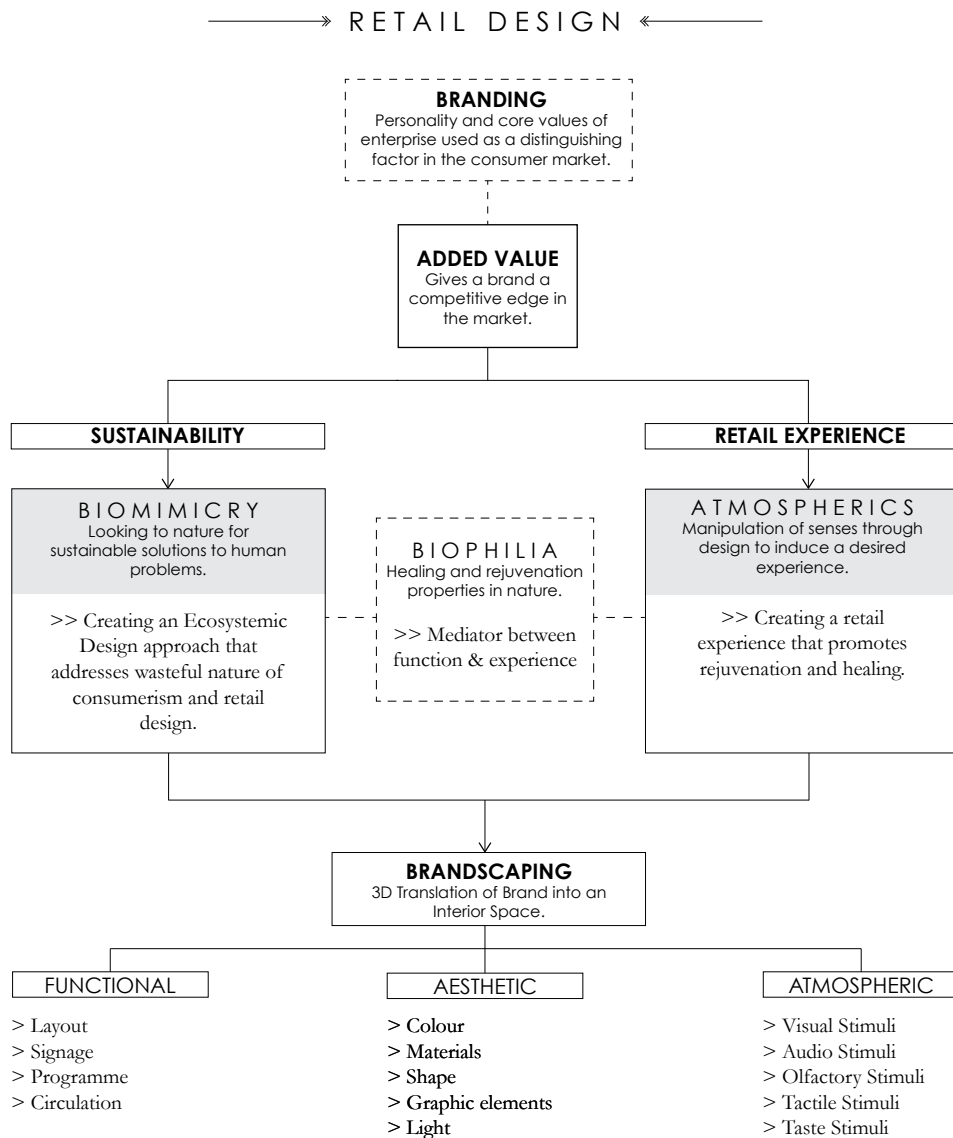

Figure 5.1. Diagram showing relationship between Retail, Biomimicry and Biophilic approach. (Author, 2016)

5.1 APPLICATION OF BRANDING STRATEGIES

It has been established in Chapter 2 that branding is a key aspect to retail design and is often used as an economic differentiator. An opportunity has been recognized to develop a new brand concept for Margaret Roberts that highlights the essence of her brand identity. This will be carried out using Kapferer's (2012) Brand Identity Prism (see Chapter 2) which states that a brand identity is composed of six elements including; *PERSONALITY*, *CULTURE*, *RELATIONSHIP*, *REFLECTION*, *SELF-IMAGE* and *PHYSIQUE*.

5.1.1 MARGARET ROBERTS BRAND IDENTITY

PERSONALITY

(character/essence of the brand)

The character/essence of the brand is to communicate a sense of healing, tranquillity and rejuvenation through medicinal herbs since this reflects the nature of Margaret Roberts' skincare products. The brand also communicates sustainable practices through packaging design and design of the retail store.

CULTURE

(values and beliefs)

Margaret Roberts herself is an inspirational figure that loves to educate people about the medicinal properties of herbs. This therefore forms part of the values and beliefs of the Margaret Roberts' brand, which aims to inspire and educate consumers.

RELATIONSHIP

(connection between brand and consumer)

Based on a personal interaction with Margaret Roberts, it can be seen that she is a kind and genuine person that loves to interact with people and provide them with advice regarding healing with herbs. Therefore, the brand aims to reflect this through establishing personal and endearing relationships with its consumers.

REFLECTION

(stereotypical consumer of brand)

The stereotypical consumer of the Margaret Roberts' brand might be someone that is looking for a sustainable skincare brand that offers organic and medicinal skincare products.

SELF-IMAGE

(persona assumed by consumer)

The persona adopted by consumers of the Margaret Roberts' brand would be suggestive of a person that acts ethically towards the environment and loves to take care of their skin with natural products.

PHYSIQUE

(logo, graphics, colour scheme, packaging)

Naming of Brand

In Chapter 3 it was established that Margaret Roberts' products are recognized by the use of her name 'Margaret Roberts' printed on the packaging, which is why it is important for her name to be used as the trademark in the new proposed brand identity. It was also found that the essence of Margaret Roberts' brand is strongly associated with the HEALING properties of HERBS, which inspired the creation of her brand/store name – "Margaret Roberts Herbal Healing".

Margaret Roberts HERBAL HEALING

Logo Design

The concept behind the logo design for Margaret Roberts' brand was to capture the trademark of the brand "Margaret Roberts" and the essence of the brand "Herbs" and "Healing" into a minimalistic yet elegant logo. The closed loop circle around the MR initials is suggestive of the closed-loop design thinking behind the brand.



Typography

The font selection was based on her recent published material, which combines a Serif and San Serif font. The Serif font (Garamond) speaks of elegance, sophistication and intellect – reflective of Margaret Roberts' nature. The San Serif font is more contemporary and minimalistic, suggesting that the brand appeals to a contemporary market.

Serif
SAN SERIF
Aa
Aa
Sophisticated
MINIMALIST

Graphics

Margaret Roberts' botanical sketches are used as graphic images in her branding and packaging design. These botanical sketches correlate with the herbal ingredients used in her skincare products.



Figure 5.2. Margaret Roberts botanical sketches (Roberts, 1984)

Colour Scheme

The colour scheme of muted greens, greys and purple/blues was developed based on a quote by Margaret Roberts;

"Tranquility is quickly and easily found by sitting quietly in the herb garden, resting the eyes on the soft, muted greens, greys and blues of the healing plants"
- Margaret Roberts, 1984

The blue is substituted with a muted purple to reflect Margaret Roberts' association with Lavender. This colour scheme resembles natural hues of colour in nature and will create a healing and tranquil association with the Margaret Roberts' brand.



Packaging

The packaging design for Margaret Roberts' skincare products implements the selected logo design, graphics and colour scheme which will be further discussed in Chapter 6.

5.2 APPLICATION OF BIOMIMICRY Towards a Sustainable Retail Design Solution

Theories discussed in Chapter 2.2; including the three levels of Biomimicry (form, processes, systems), Life's Principles and specific theories relating to resource efficiency and waste management, are applied in the concept development in order to address the real world problem of resource inefficiency and waste produced in the retail sector.

5.2.1. DISCOVERING EXAMPLES IN NATURE

Step 4 in the Biomimicry Design process is to discover biological models in nature, which can provide inspiration on how to address the problem through design. Since Margaret Roberts is associated with medicinal herbs, and more specifically the lavender plant, it was decided that design inspiration should be obtained from the lavender plant.

Resource Efficiency through Emulation of FORM

The microscopic cell structure of the Lavender plant shows evidence of hexagonal patterns supported by a triangulated network. This relates back to Pearce's theory of closest packing and triangulation (Pearce, 1978) as discussed in Chapter 2. The hexagonal cell structure is considered resource efficient since it requires the least amount of material to develop this type of structure (Pearce, 1978). Additionally, the triangulated network is essential to the structural integrity of the plant, allowing it to be robust and resilient, therefore allowing the plant material to survive for much longer.

Therefore, the design concept aims to explore the use of triangulated forms and structures; as seen in nature, towards developing a resource efficient retail design solution.



LAVENDER PLANT

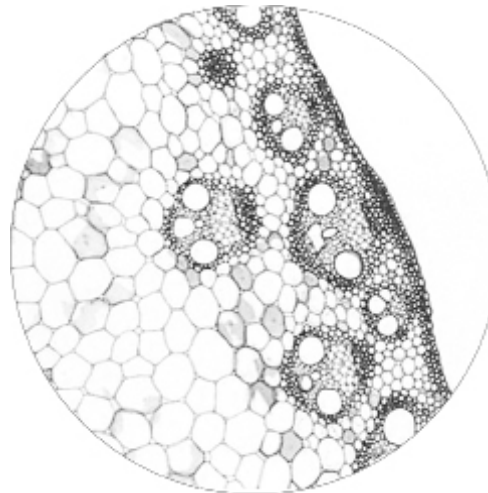

PLANT CELL STRUCTURE

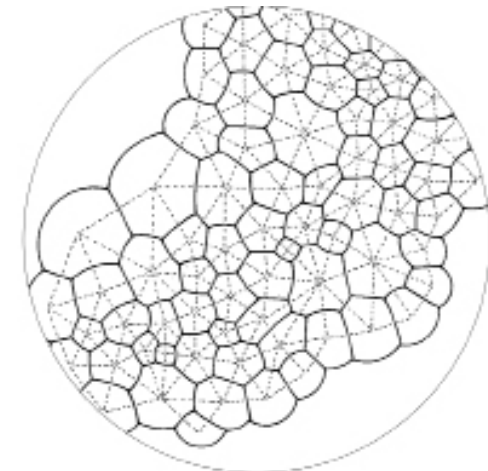

PLANT CELL TRIANGULATION

Figure 5.3. Lavender triangulated cell structure (Author, 2016).

Precedent Studies: Triangulation in Architecture & Design

Al Bahar Towers

Abu Dhabi

The Al Bahar Towers in Abu Dhabi showcases the use of hexagonal and triangulated patterns in the design of its 'second skin' around the exterior of the building. The design was inspired by a traditional Islamic lattice-shading device named "mashrabiya" and also resembles a honeycomb-like structure. The 'second skin' acts as a solar-responsive shading device that mediates daylight and reduces glare. Solar energy is used to provide a power supply to the dynamic structure (Teicu, 2012).

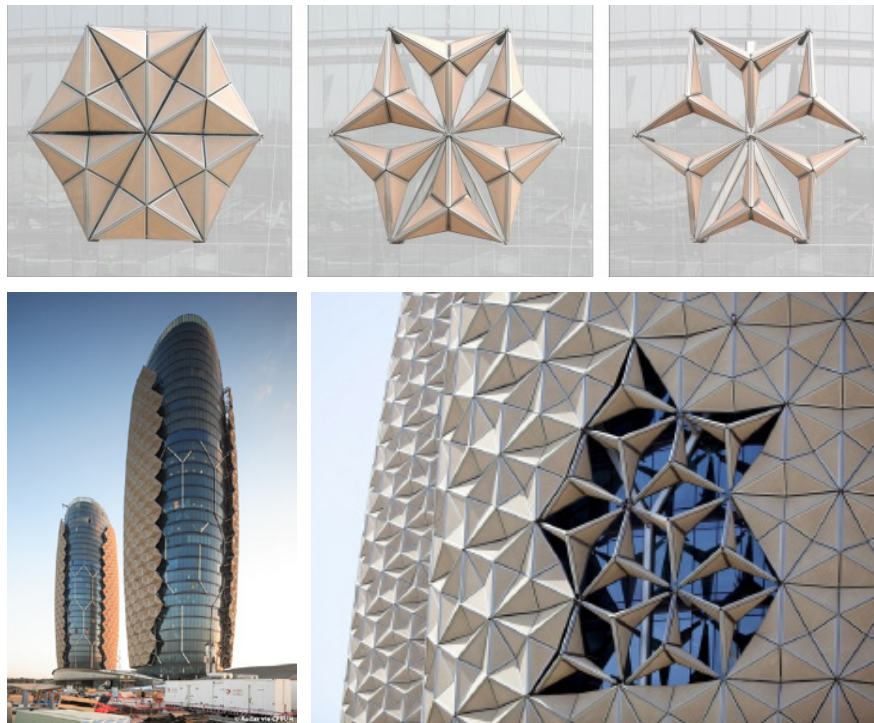

Figure 5.4. Al Bahar Towers (Teicu, 2012).

Kolding Campus

SDU University of Southern Denmark

The design of the Kolding Campus building implements the use of triangulation in the design of its 'intelligent facade'. The facade features a series of perforated triangular metal components that adjust according to daylight conditions in order to regulate the lighting conditions of the building's interior structures provide various design applications within an interior space (Ongreening, 2016).



Figure 5.5. Kolding Campus (Ongreening, 2016).

Waste Management through Emulation of PROCESSES & SYSTEMS

The lifecycle of the Lavender plant is a closed-loop system in which 'waste' is recycled back into the system and used as a resource. The Lavender plant only uses 'locally sourced material'; it harvests rainwater, and uses energy from the sun. Through the process of photosynthesis, the lavender plant sequesters Carbon Dioxide and releases Oxygen into the atmosphere. It also forms symbiotic relationships with other insects, such as bees that collect nectar from the lavender flowers, whilst simultaneously pollinating the lavender plant. At the end of its lifecycle, the lavender plant will decompose and provide rich nutrients for new lavender plants to grow, thus creating a closed-loop/ cradle-to-cradle system.

Therefore, the aim of the design concept is to mimic the processes and systems identified in the closed-loop ecosystem of the lavender plant in order to reduce waste.

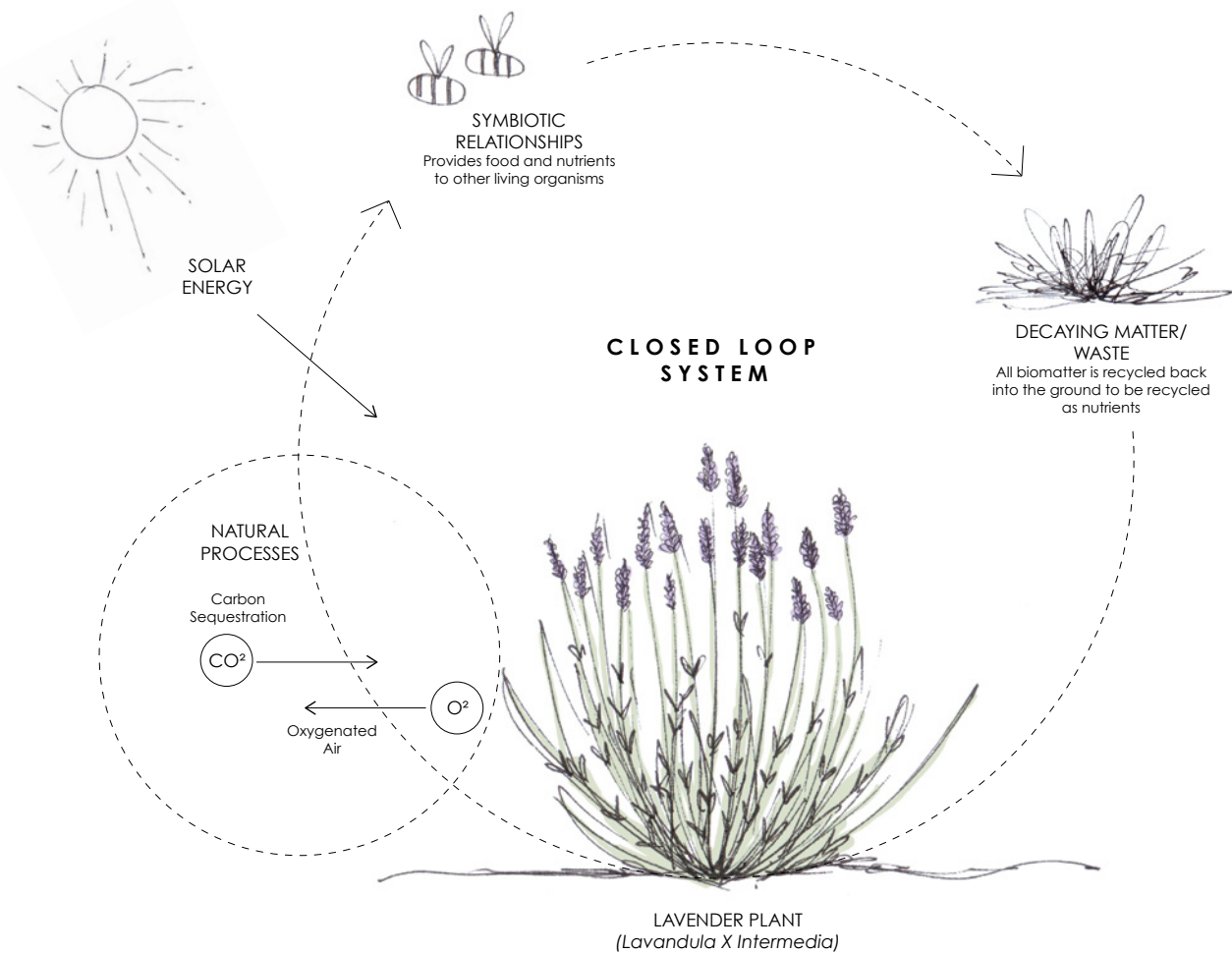

Figure 5.6. Lavender Closed-Loop System (Author, 2016).

Precedent Study: Passive Systems

Eastgate Centre

Harare, Zimbabwe

The design of the Eastgate Centre in Harare follows the Biomimicry principles and was inspired by the passive ventilation system identified in termite mounds. The building is not supported by artificial ventilation systems but rather makes use of its thermal mass to heat or cool the air that circulation through the building. This design feature allows the Eastgate Centre to operate with 10% of the energy of conventional buildings. (Doan, 2012).

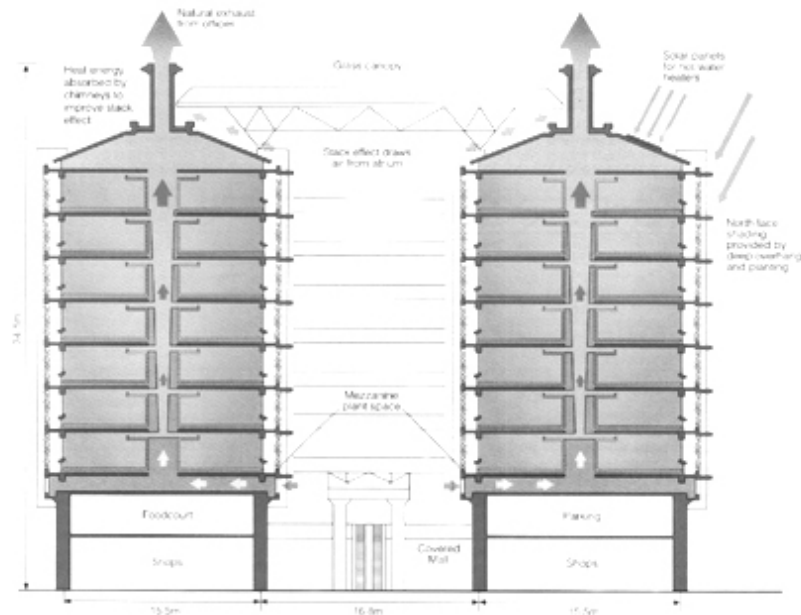

Figure 5.7. Eastgate Centre, Harare (Doan, 2012).

Passive Systems Concept

Part of the design concept is to propose the introduction of passive systems including the use of natural daylight, passive ventilation and harvesting of solar energy in the retail space to emulate the systems identified in the lifecycle of the lavender plant.

Daylight

The chosen site; Shop 150 in Irene Mall, has large shopfront windows that is north facing allowing natural daylight to filter into the interior space. However, the depth of the interior space prevents natural light from reaching the full extent of the space, which is why it is proposed to introduce skylights or light tunnels in areas that require additional lighting.

Passive Ventilation

The chosen site is a freestanding building that allows direct access to the roof. This creates an opportunity to introduce a passive ventilation system much like the system applied in the Eastgate Centre, in which fresh air from outside the building is circulated through the interior space and exhausted through a solar chimney in the roof.

Solar Energy

Harvesting of solar energy can be achieved through introducing a photovoltaic solar system onto the roof structure that will supply energy to power the interior systems.

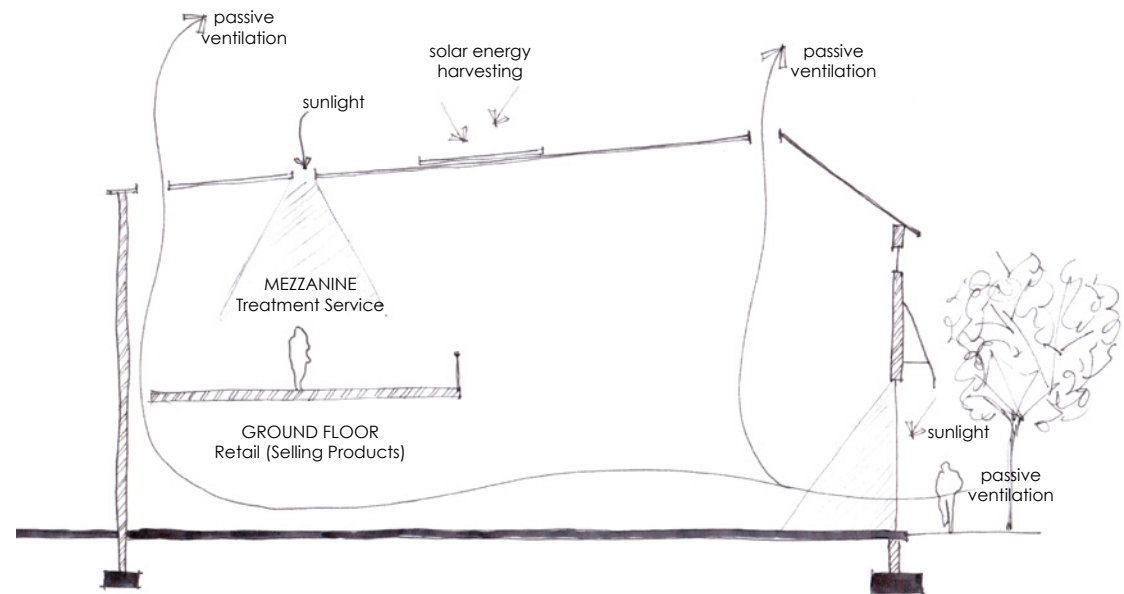

Figure 5.8. Diagram: Passive Systems (Author, 2016).

5.3 APPLICATION OF EXPERIENTIAL & BIOPHILIC DESIGN THEORY

Towards an in-store brand experience

The experiential design concept for Margaret Roberts' servicescape is a synergy between the brand essence (see Chapter 3) and the application of Biophilic patterns (see Chapter 2).

The idea is to create a sensory experience in the design of Margaret Roberts' servicescape, which mimics the atmospheric qualities in nature in order to develop calming and rejuvenating experience. This idea is relative to the essence of the Margaret Roberts' brand since her skincare products are associated with healing through herbs (nature).

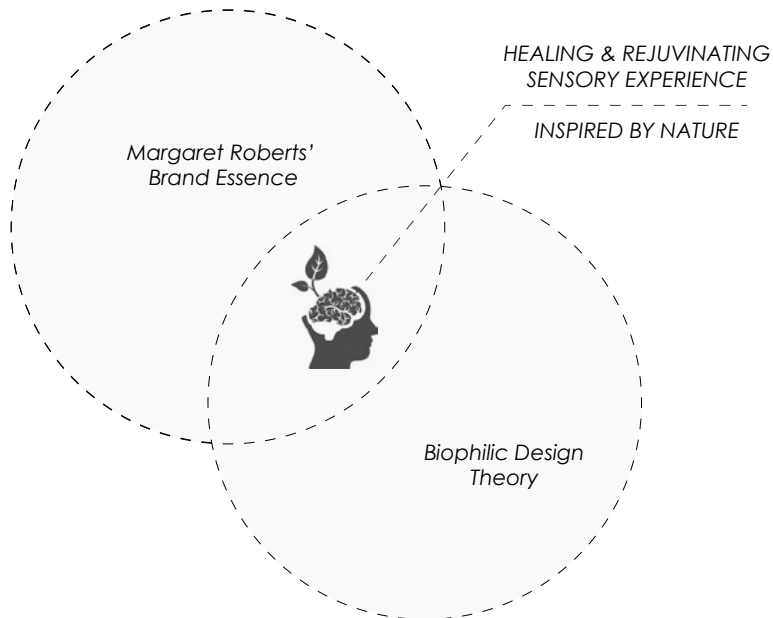

Figure 5.9. Experience design diagram (Author, 2016).



Figure 5.10. Experiential design journey (Author, 2016).

BIOPHILIC SENSORY EXPERIENCE INFLUENCES

The experiential design concept relies on the biophilic patterns in nature identified in Chapter 2 and are summarised below according to the 5 senses.





SENSES	BIOPHILIC SENSORY EXPERIENCE
	<ul style="list-style-type: none"> > [P1] Create a visual connection with nature > [P6] Incorporate dynamic and diffused lighting strategies > [P8] Apply biomorphic forms and patterns in the design strategy > [P10] Create complexity and order through design
	<ul style="list-style-type: none"> > [P2] Create a non-visual connection with nature (auditory) (introduce nature sounds and music that resembles rhythms in nature)
	<ul style="list-style-type: none"> > [P2] Create a non-visual connection with nature (tactile) > [P4] Create thermal and airflow variability > [P9] Create a material connection with nature
	<ul style="list-style-type: none"> > [P2] Create a non-visual connection with nature (olfactory) (introduce natural and fresh smells)
	<ul style="list-style-type: none"> > [P2] Create a non-visual connection with nature (gustatory) (present clients with refreshments made from organic and natural ingredients)

Table 5.1 Biophilic Sensory Experience (Author, 2016).

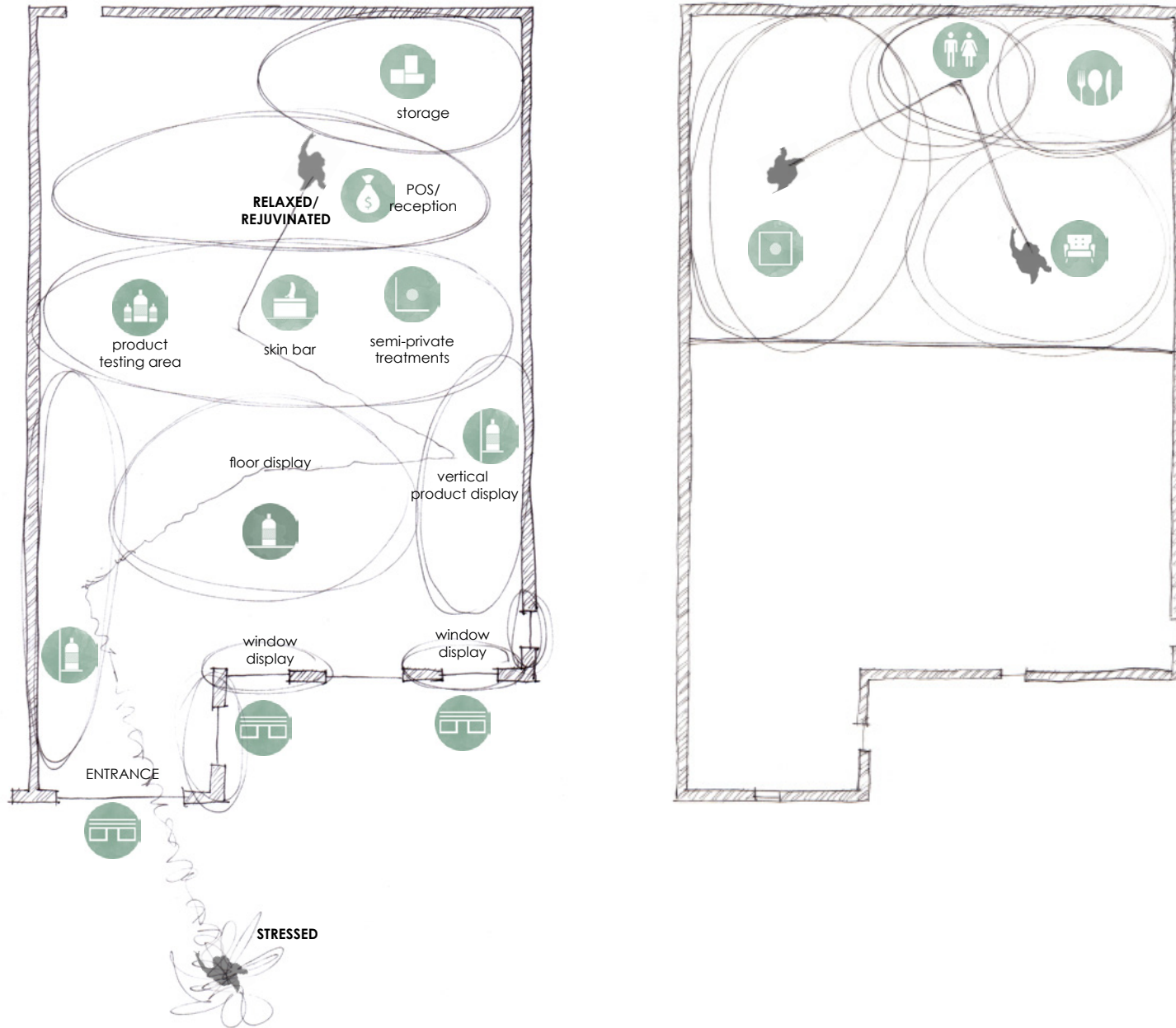

Figure 5.11. Diagram showing map of experiential design journey (Author, 2016).



DESIGN DISCOURSE

ABSTRACT

This chapter applies the theories discussed in Chapter 2, and the conceptual approach as defined in Chapter 5, towards the design of a retail skincare servicescape for Margaret Roberts. Biomimetic theories are applied towards the functional and sustainable aspects of the design, and Biophilic theories and patterns are applied towards creating a rejuvenating in-store experience.

06

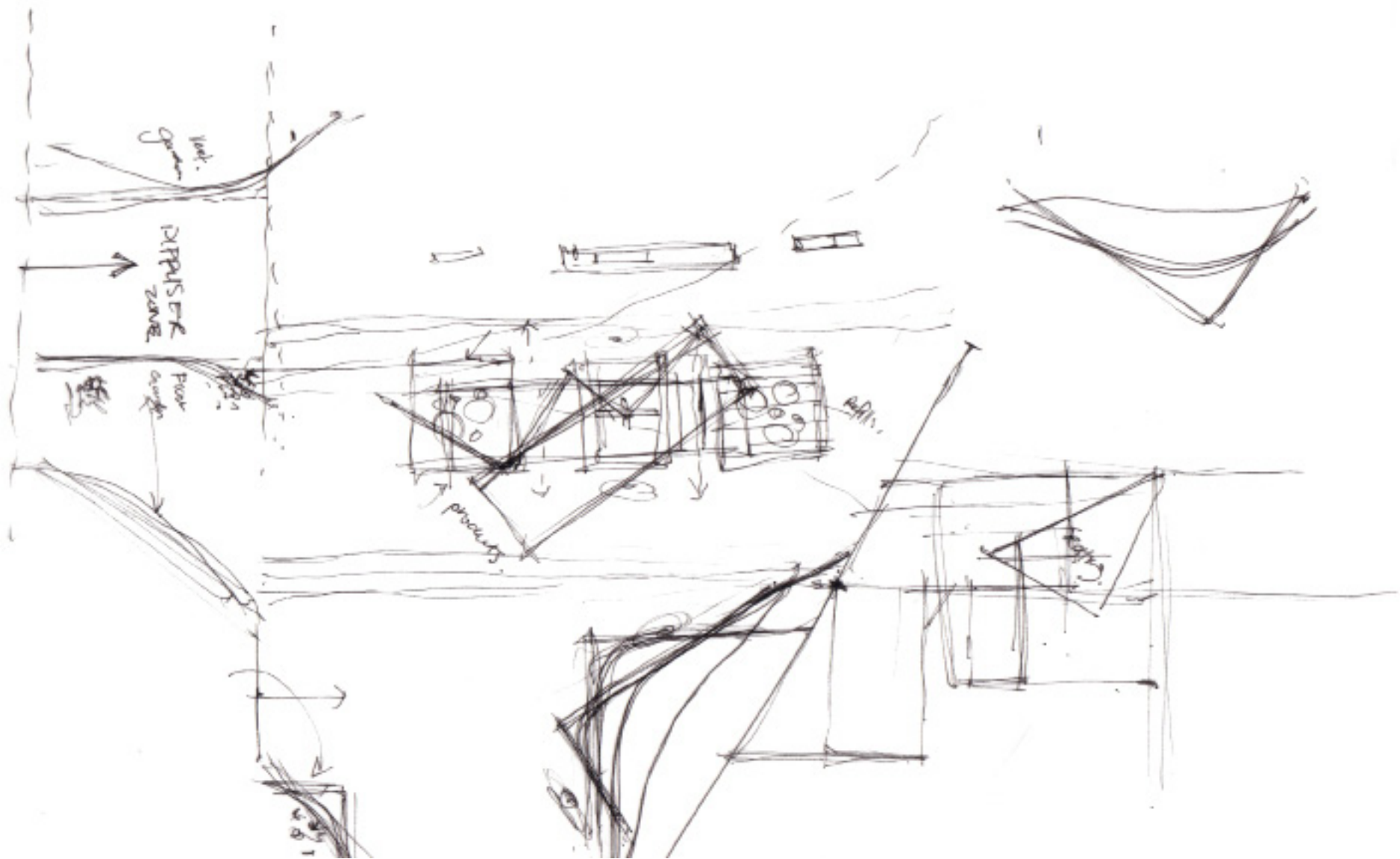

Figure 6.1 Concept development sketch
(Author, 2016).

DESIGN STRATEGY

Nature as a Model and Mentor

BIOMIMICRY DESIGN

BIOPHILIC DESIGN

Towards Sustainable Retail Design

Towards an In-store Retail Experience

RESOURCE EFFICIENCY

Life's Principles:

- > Design for adaptability
- > Combine modular and nested components
- > Use multifunctional design
- > Incorporate diversity
- > Replicate strategies that work

Minimum Inventory/
Maximum Diversity

Modular Kit of Parts

Resource Efficiency
through Form:
Triangulation Patterns

WASTE MANAGEMENT

Life's Principles:

- > Leverage cyclic processes
- > Use readily available materials
- > Recycle all materials
- > Break down products into benign constituents

Closed-Loop System

Use waste as a resource

SENSORY EXPERIENCE



Create a **visual connection** with nature through manipulation of plants, natural light, biomorphic forms and patterns, and complexity and order.



Create an **auditory connection** with nature through controlling noise and silence, and introducing nature sounds.



Create an **olfactory connection** with nature by introducing soft, natural and refreshing scents.



Create a **tactile connection** with nature through manipulating airflow and temperature variables and introducing raw and natural materials.



Create a **gustatory connection** with nature through providing natural and earthy refreshments to clients.

Figure 6.2. Diagram of Design Strategy (Author, 2016)

6.1 BIOMIMICRY DESIGN APPLICATION

6.1.1. RESOURCE EFFICIENCY THROUGH EMULATION OF BIOMIMETIC **FORM**

Chapter 2 discussed Pearce (1978) and Thompson’s (1961) theory on forms and structures in nature that are resource efficient, which both highlighted the significance of triangulation patterns in nature. In Chapter 5, the lavender plant was identified as the biological organism used as a source for design inspiration. By dissecting the composition of the lavender plant, it was found that the microscopic cell structure shows evidence of triangulation patterns. Therefore, the design strategy aims to implement the use of triangulation patterns as a means of emulating resource efficient biomimetic forms.

It was decided to explore the application of triangulation patterns in a retail display system since retail displays can be resource intensive due to the fact that they are often changed or replaced to keep up with trends and seasonal changes.

The aim for the display system was to create a structure that would allow for adaptation, deconstruction and would display resource efficient qualities through its triangulated form and material application.

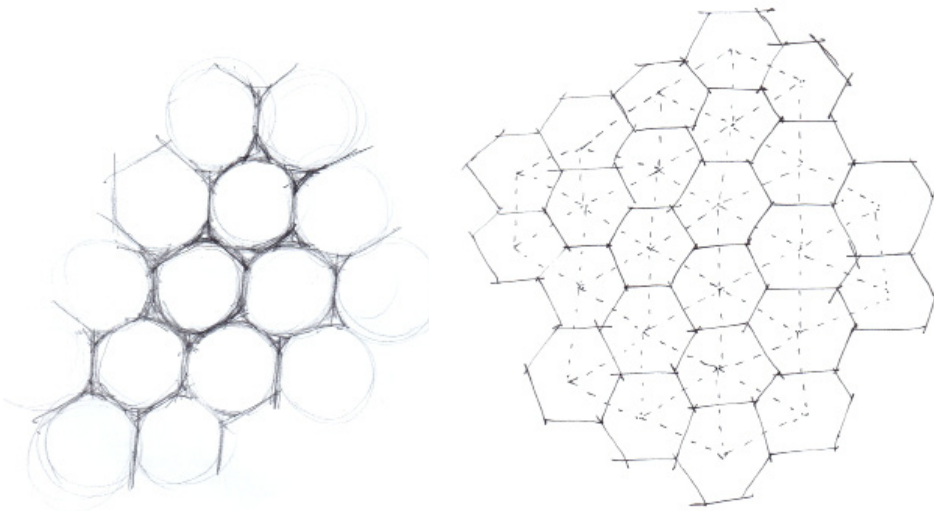

Figure 6.3. Sketch of triangulation patterns in lavender cell structure (Author, 2016)

TRIANGULATED GRID STRUCTURE

The sketch below shows development of a triangulated grid structure that emulates the triangulation patterns identified in the cell structure of the lavender plant.

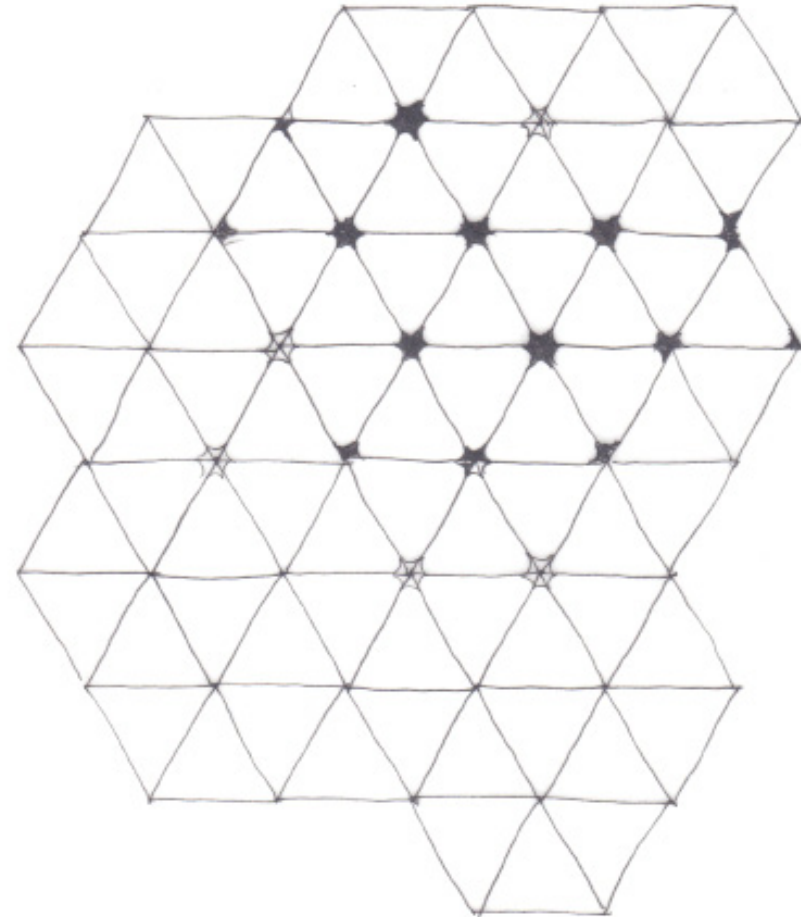

Figure 6.4. Triangulated grid structure (Author, 2016)

EXPLORATION OF FRACTAL PATTERNS IN THE TRIANGULATED GRID STRUCTURE

The sketch below shows how the triangulated grid structure can be manipulated to incorporate fractal patterns (see Chapter 2).

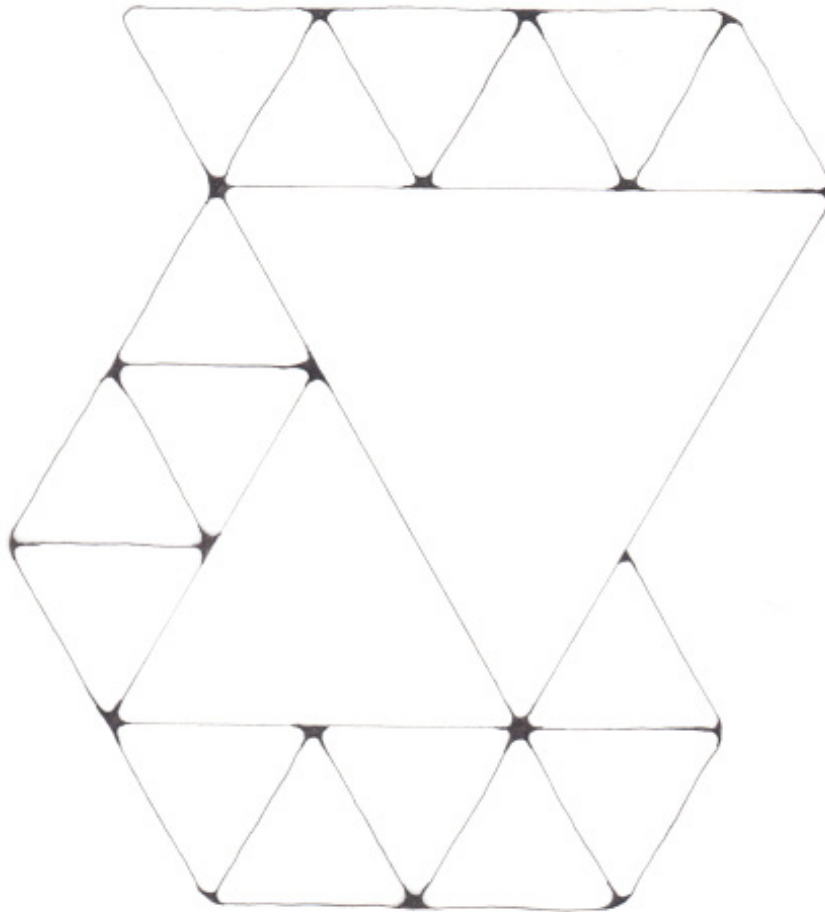

Figure 6.5. Triangulated grid structure - fractal patterns (Author, 2016)

EXPLORATION OF DISPLAY SYSTEM WITHIN TRIANGULATED GRID STRUCTURE

The sketch shows how a display system can be created with the triangulated grid structure, allowing room for product displays and information displays.

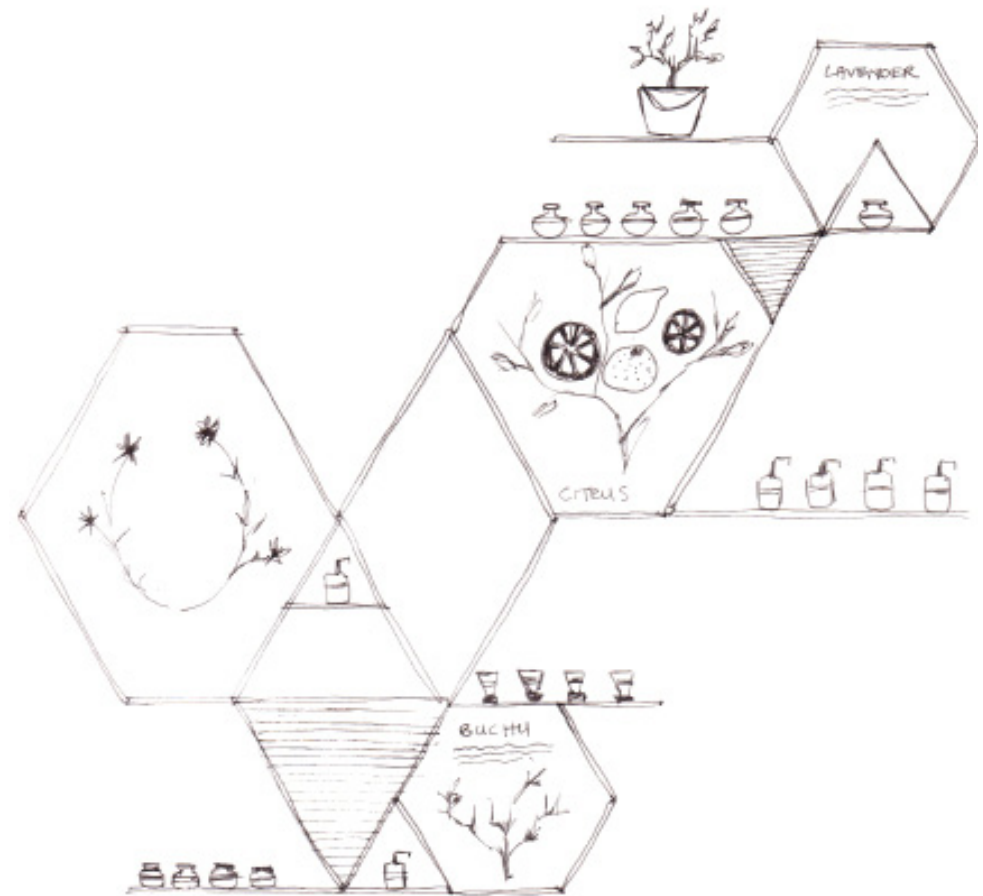

Figure 6.6. Triangulated grid structure - display design (Author, 2016)

Design of Triangulated Display System

The design of the display system is constructed according to the triangulated grid. These sketches show how the structure allows the creation of various design configurations – rendering the system highly adaptable.

The approach to the arrangement of products within the display was influenced by the ergonomical parameters for the design of a vertical display as defined in Chapter 4. Products and information displays are to be arranged between **stretch level** and **stoop level** to ensure visual and physical accessibility.

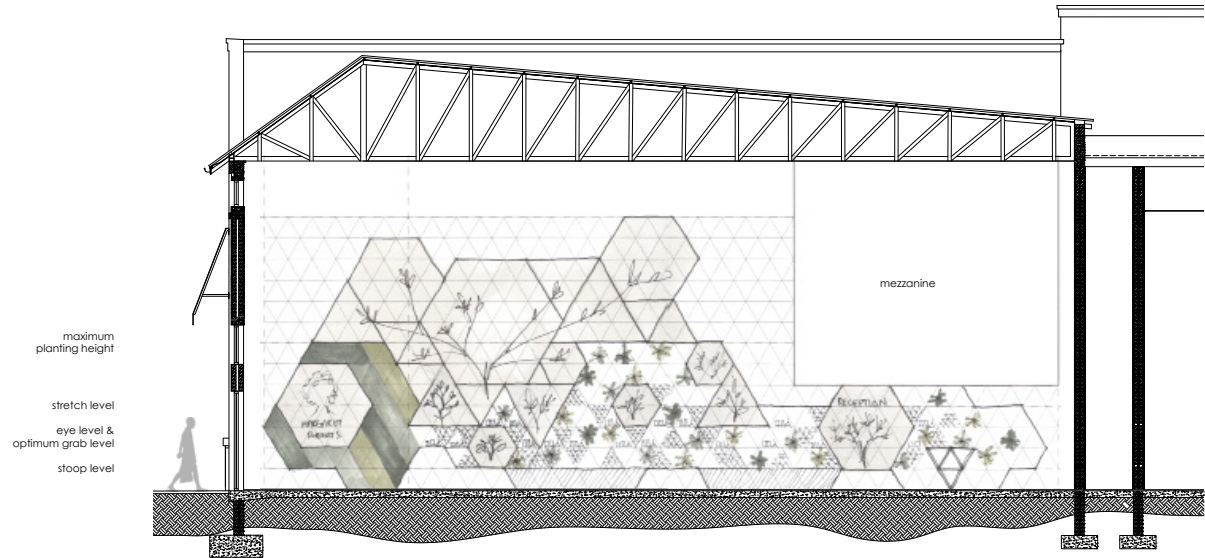

Figure 6.8. Triangulated vertical display configuration 1 (Author, 2016)

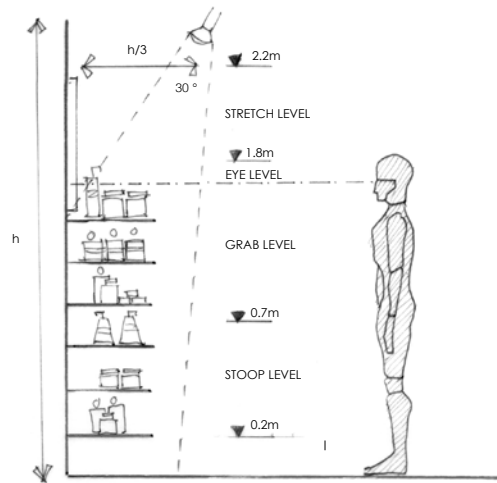

Figure 6.7. Vertical display ergonomics (Author, 2016) compare with (Panero & Zenik, 1979)

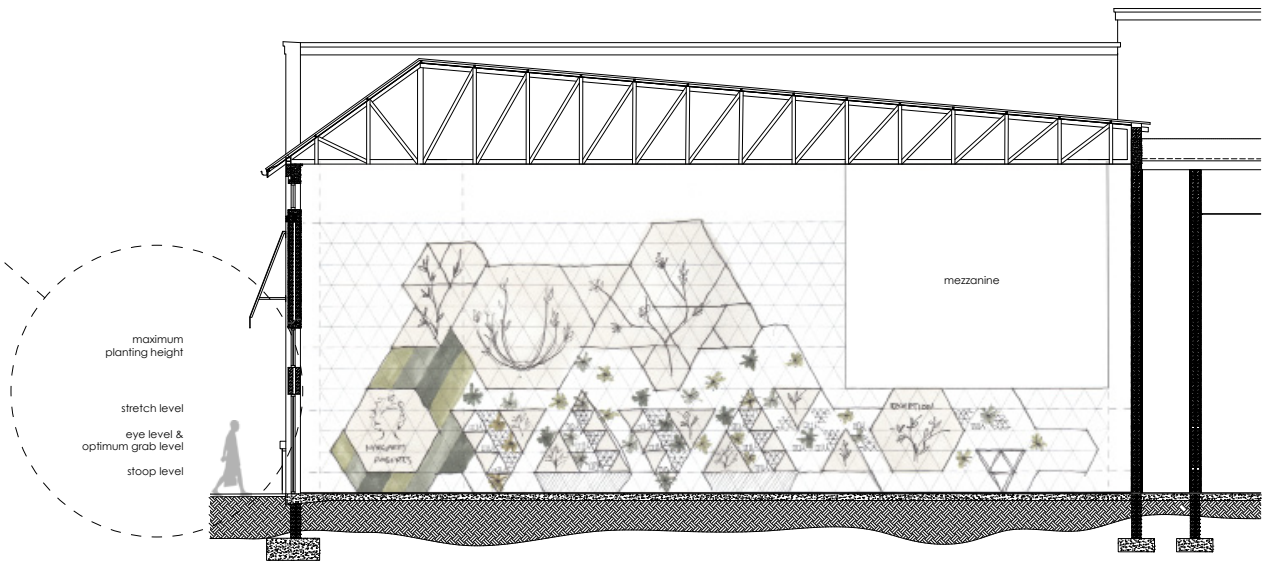

Figure 6.9. Triangulated vertical display configuration 2 (Author, 2016)



Figure 6.10. 3D visualisation of display system (Author, 2016).

Precedent Study : Deconstructable Joinery

Keystones Furniture

By *Minale-Maeda*

Dutch design studio Minale-Madae have created a series of furniture pieces that makes use of 3D printed connectors as an alternative to traditional joinery methods. These 3D printed connectors are designed to connect multiple ply wood components, which are assembled together to create the furniture pieces. The 3D printing technology allows the joints to be printed with minimal material and creates a joinery system that favours design for disassembly and adaptability (Homeli, 2016).



Figure 6.11. 3D Printed joinery by Minale-Madae (Homeli, 2016)

Design for Adaptability: Deconstructable Joinery

The 3D printed joinery designed by Minale-Madae (Homeli, 2016) inspired the design of joinery for the triangulated display system that allows for adaptability through deconstruction and disassembly. The structure of the joints mimics the material dispersal between the cellular structures of the lavender plant.

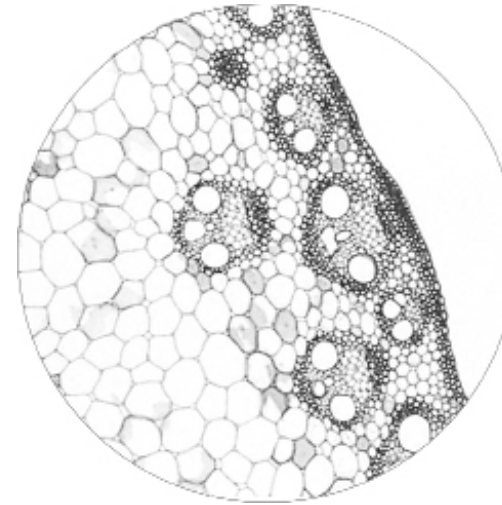
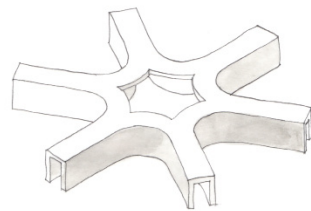
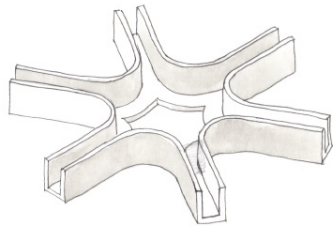
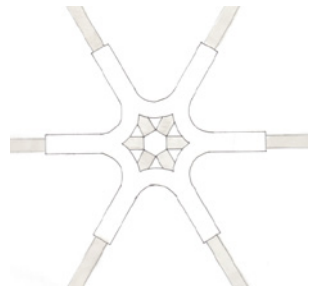

5 DIFFERENT JOINT COMPONENTS

Five different joint components have been designed in order to make provision for various design configurations of the display system within the triangulated grid structure.

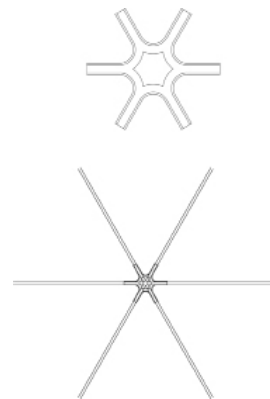

6 point joint

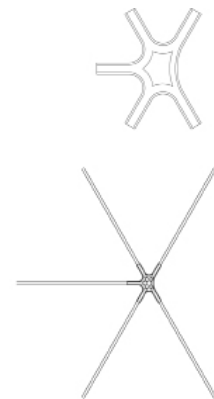

5 point joint

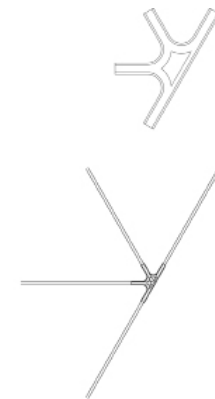

4 point joint

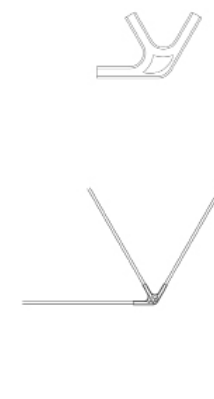

3 point joint



2 point joint

Figure 6.12. Joinery design (Author, 2016)

Figure 6.13. 5 Different joinery components (Author, 2016)



Precedent Study : Triangulated Ceiling Installation

Resonant Chambers

University of Michigan

The Resonant Chambers is an origami-inspired interior envelope system used to transform the acoustic qualities of a space. The triangular tessellated surface can be adjusted and configured to influence acoustic properties such as ‘reverberation time, absorption coefficient, directional amplification etc’ (Furuto, 2012).

This precedent study shows how triangulated structures provide various design applications within an interior space.



Figure 6.14. Resonant Chambers (Furuto, 2012).

Triangulated Membrane Design

The design of the resonant chambers inspired the creation of a tessellated membrane that resembles the softness and fluidity of human skin, which can be used as a ceiling installation in the design for Margaret Roberts’ skincare servicescape. The membrane was created through folding and ironing of triangulated creases to create a rigid yet fluid structure.

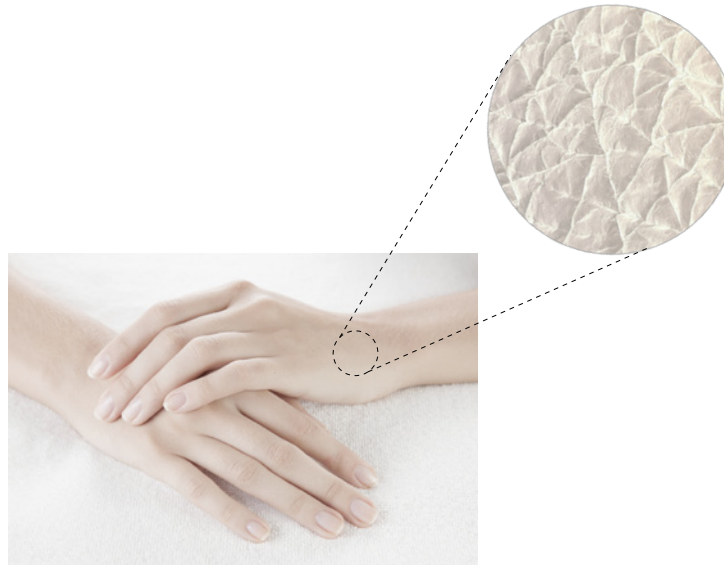

Figure 6.15. Human Skin cell structure (Author, 2016).



Figure 6.16. Triangulated membrane (Author, 2016).



Precedent Study : Triangulated Packaging Design

SHIZEN Packaging

By In-Young Bae

The SHIZEN packaging design; inspired by the principle of Japanese gardens - “creating miniature idealized landscapes”, showcases the clever use of triangulation. The triangular shape of the packaging allows 5 separate boxes to be stacked together to create one unified package (Lin, 2014).



Figure 6.17. SHIZEN Packaging (Lin, 2014).

Concept Development of Packaging Design

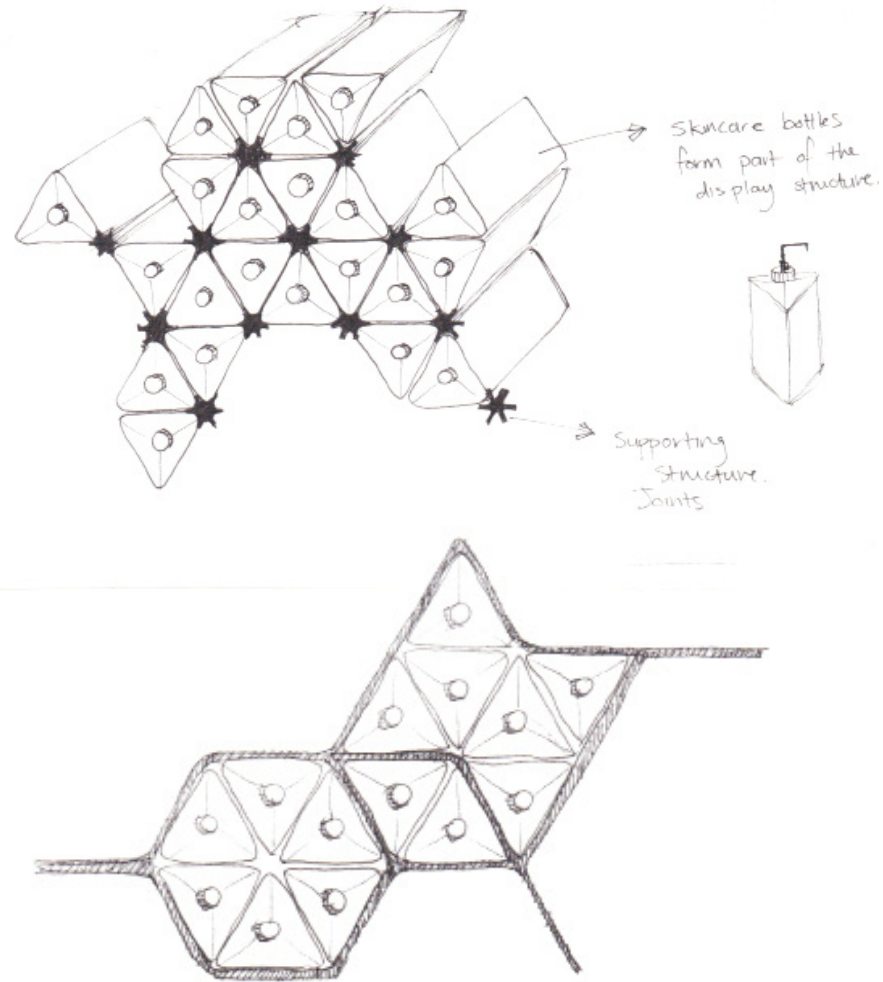
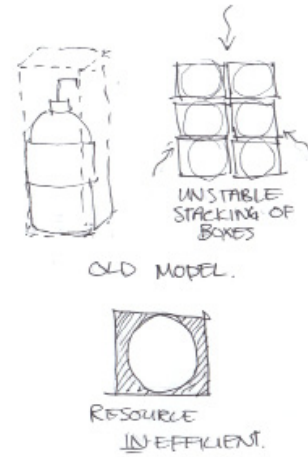

Figure 6.18. Triangulated packaging design (Author, 2016).

SQUARE PACKAGING



V.S.

TRIANGULAR PACKAGING

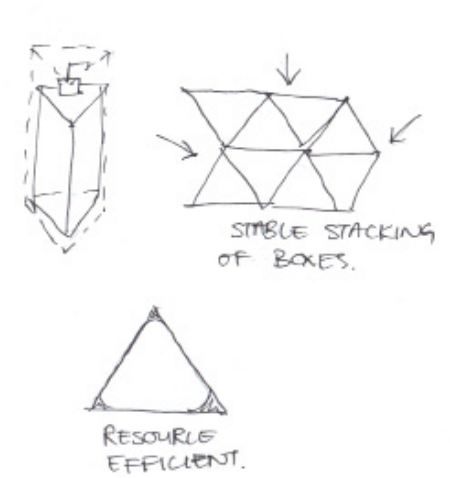

FRACTALS OF PACKAGING

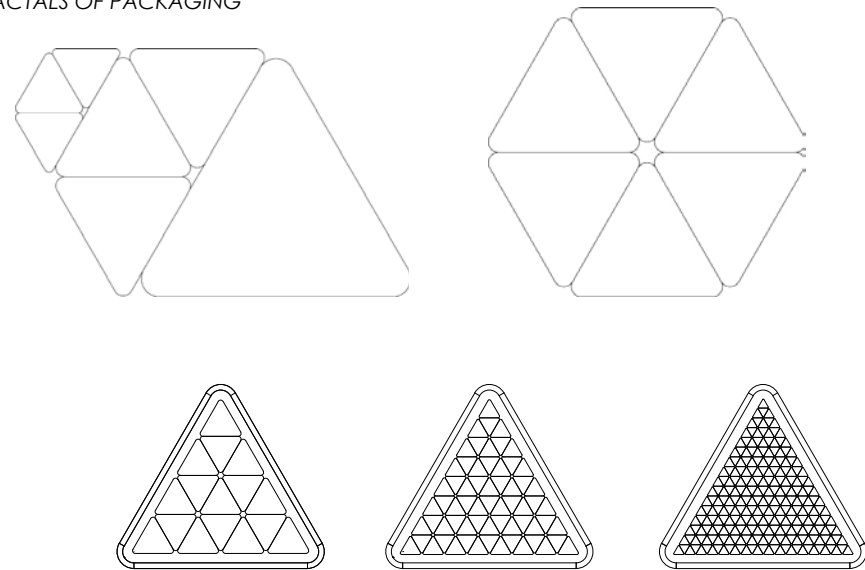

Figure 6.19. Triangulated packaging design (Author, 2016).

Packaging Die Lines

ITERATION 1

The first iteration of packaging design proved to create a lot of waste in the form of off-cuts and did not provide any support in the bottom of the packaging.

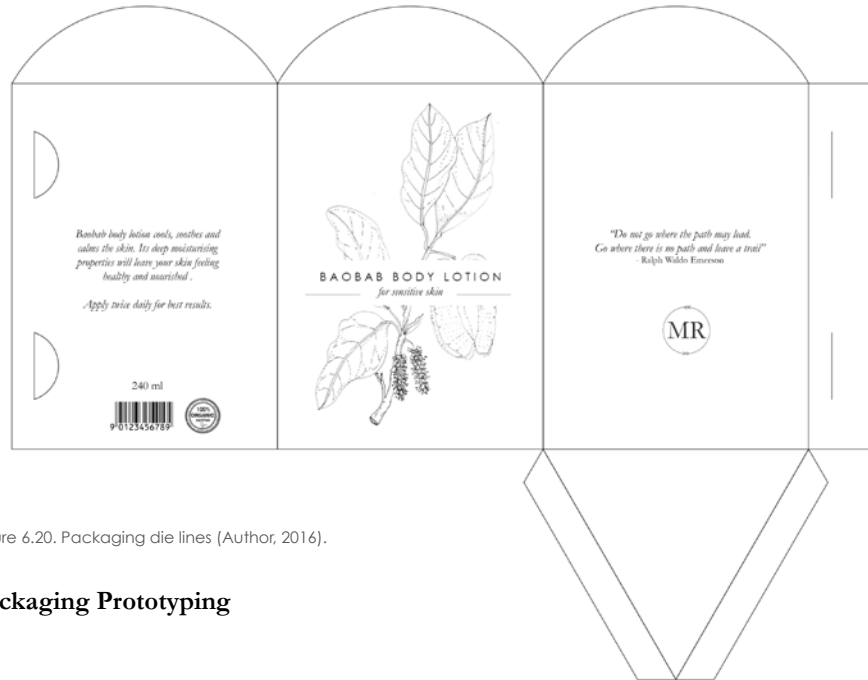

Figure 6.20. Packaging die lines (Author, 2016).

Packaging Prototyping

ITERATION 2

The second iteration aimed to use the 'off-cuts' to create reinforcement for the base of the packaging.

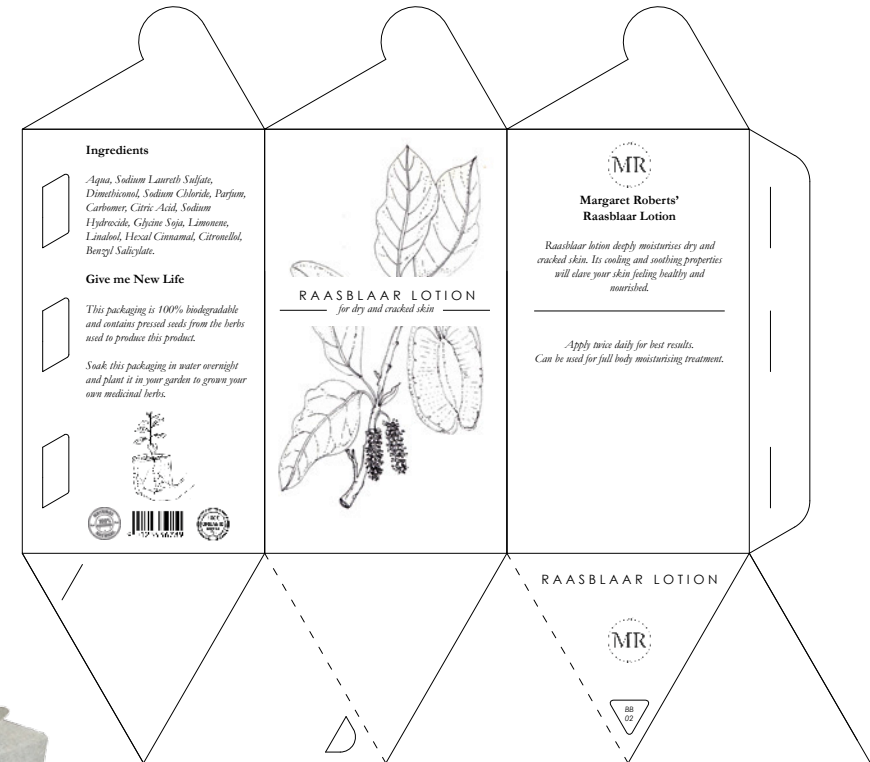

Figure 6.21. Product packaging design (Author, 2016).



Figure 6.22. Product label design (Author, 2016).

6.1.2 WASTE MANAGEMENT THROUGH EMULATION OF BIOMIMETIC SYSTEMS

Using Waste as a Resource

McDonough and Braungart's theory (2002) on cradle-to-cradle design discussed in Chapter 2 inspired the creation of a closed-loop model that emulates nature's ecosystems.

The design of the closed loop model is based around the waste produced as a byproduct of the essential oil distillation process carried out to manufacture Margaret Roberts' skincare products (see Chapter 3). It was established that the distillation process had a very low yield of 0.1% and as a result produced a large volume of waste in the form of organic lavender straw. An opportunity was recognized to create a biological metabolism (McDonough & Braungart, 2012) which recycles the lavender straw and uses it as a resource for developing biodegradable packaging and organic fibre composite boards for the display system.

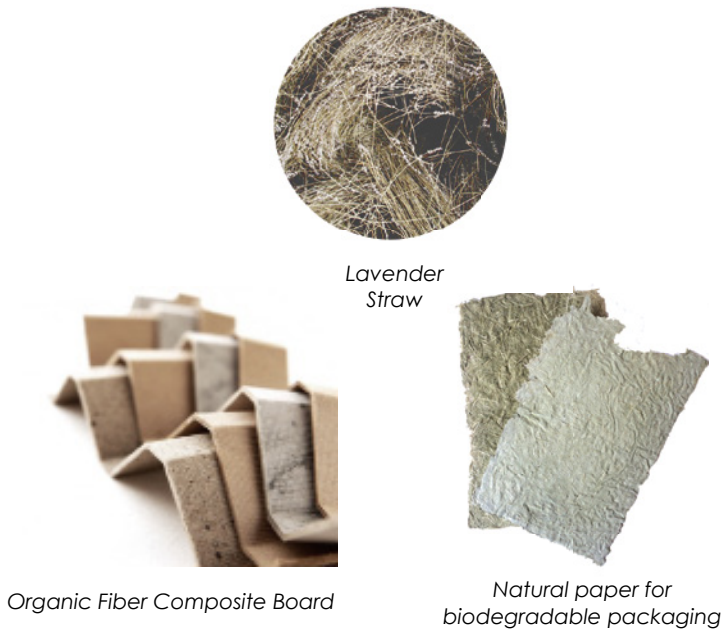

Figure 6.23. Lavender straw to create fiber composite boards and biodegradable packaging material (Author, 2016).

Precedent Study : Compostable Packaging

Biodegradable Food Bowl

By Michal Marko

Michal Marko's vision for the design of his Biodegradable Food Bowl was to create an alternative packaging material with minimum impact on the environment. The packaging contains small seeds underneath the label which can be planted within the packaging in order to grow your own herbs (DesignandPaper, 2013).



Figure 6.24 Biodegradable Food Packaging (DesignandPaper, 2013)

Existing Organic Fiber Composites

Coconut Fiber Composite



Figure 6.25. Coconut fiber composite (Sharpe, 2013)

Bamboo Fiber Composite



Figure 6.26. Bamboo fiber composite column (Hartford, 2012)

6.1.2.1 Closed-Loop System Design

- > Lavender plant is harvested to produce essential oils for Margaret Roberts' skincare products
- > The organic waste (lavender straw) is collected and processed to produce formaldehyde-free biodegradable packaging and organic composite boards for display system (containing lavender seeds)
- > The skincare products in biodegradable packaging is purchased by consumers
- > Biodegradable packaging (containing pressed lavender seeds) can be buried in soil, which will germinate the pressed seeds and allow the growth of a new lavender plant
- > Once at the end of their lifecycle, the organic fiber composite boards used for the display system will be broken down and used as a composting material to support the growth of lavender crops
- > The lavender crops will then be harvested for essential oil production purposes

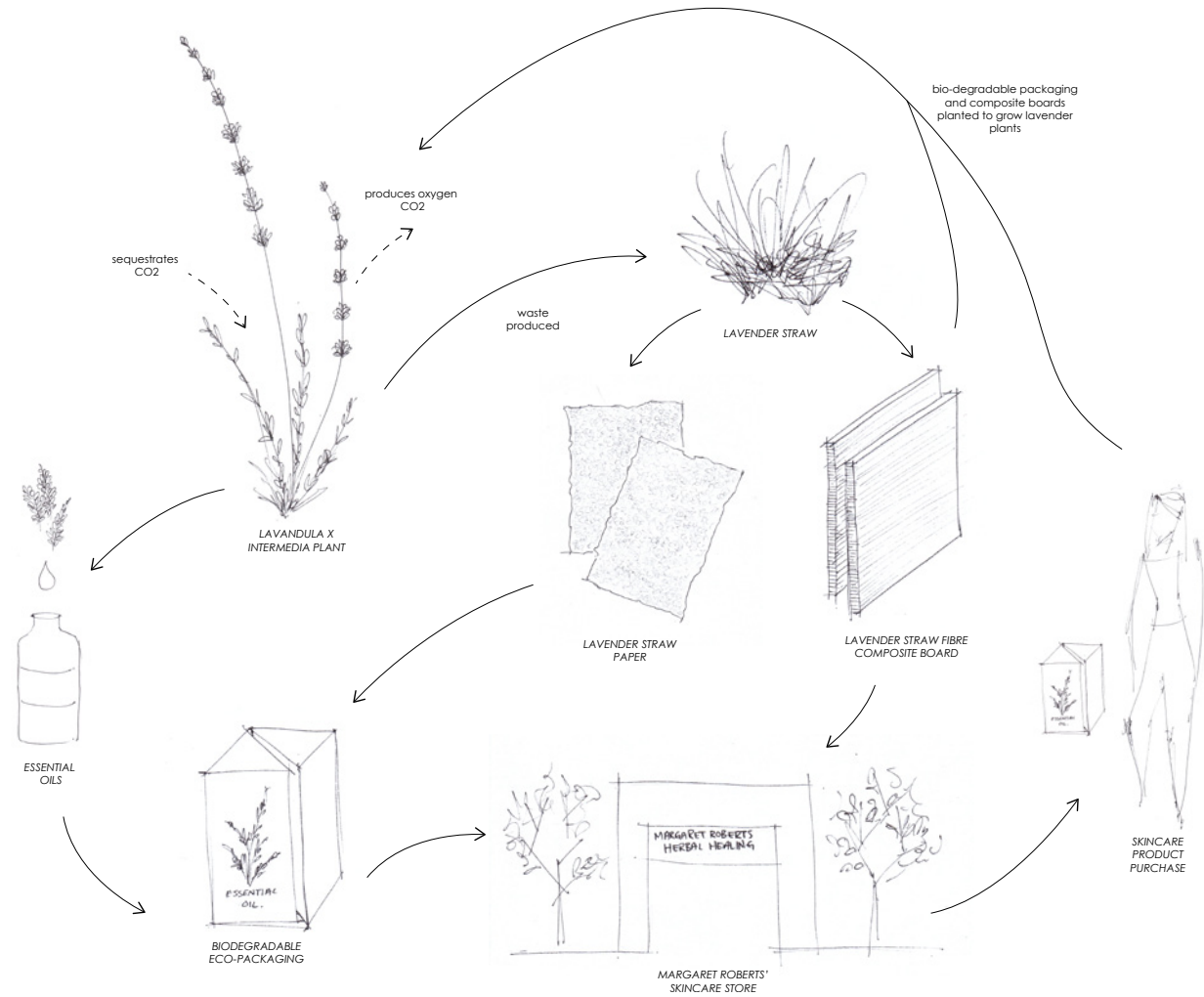

Figure 6.27. Closed-loop system design (Author, 2016).



Making of Lavender Fiber Paper

Part of the conceptual development of packaging design involved the exploration of using lavender straw to create an organic lavender fiber paper. This process was carried out using no binding agents and simply relied on the natural composition of the lavender fibers to create a bond strong enough to form a paper-like material.

The process of making the lavender fiber paper is as follows:

STEP 1:

Harvest fresh lavender and cut into small pieces

STEP 2:

Boil lavender and extract lavender oils through distillation process

STEP 3:

Blend leftover plant material (waste) and water to form a pulp like consistency

STEP 4:

Rinse and strain lavender pulp to remove impurities

STEP 5:

Strain lavender pulp over a fine mesh that is framed according to the desired paper size and leave in a cool dry place to dry slowly

STEP 6:

Gently remove lavender sheet from mesh and frame

STEP 7:

Lavender paper making process is complete.

The resulting lavender fiber paper is surprisingly rigid but will not be strong enough to create packaging without a binding agent. Therefore it is recommended to use a protein glue and NOT formaldehyde as a binding agent for creating the packaging material from lavender fibers.

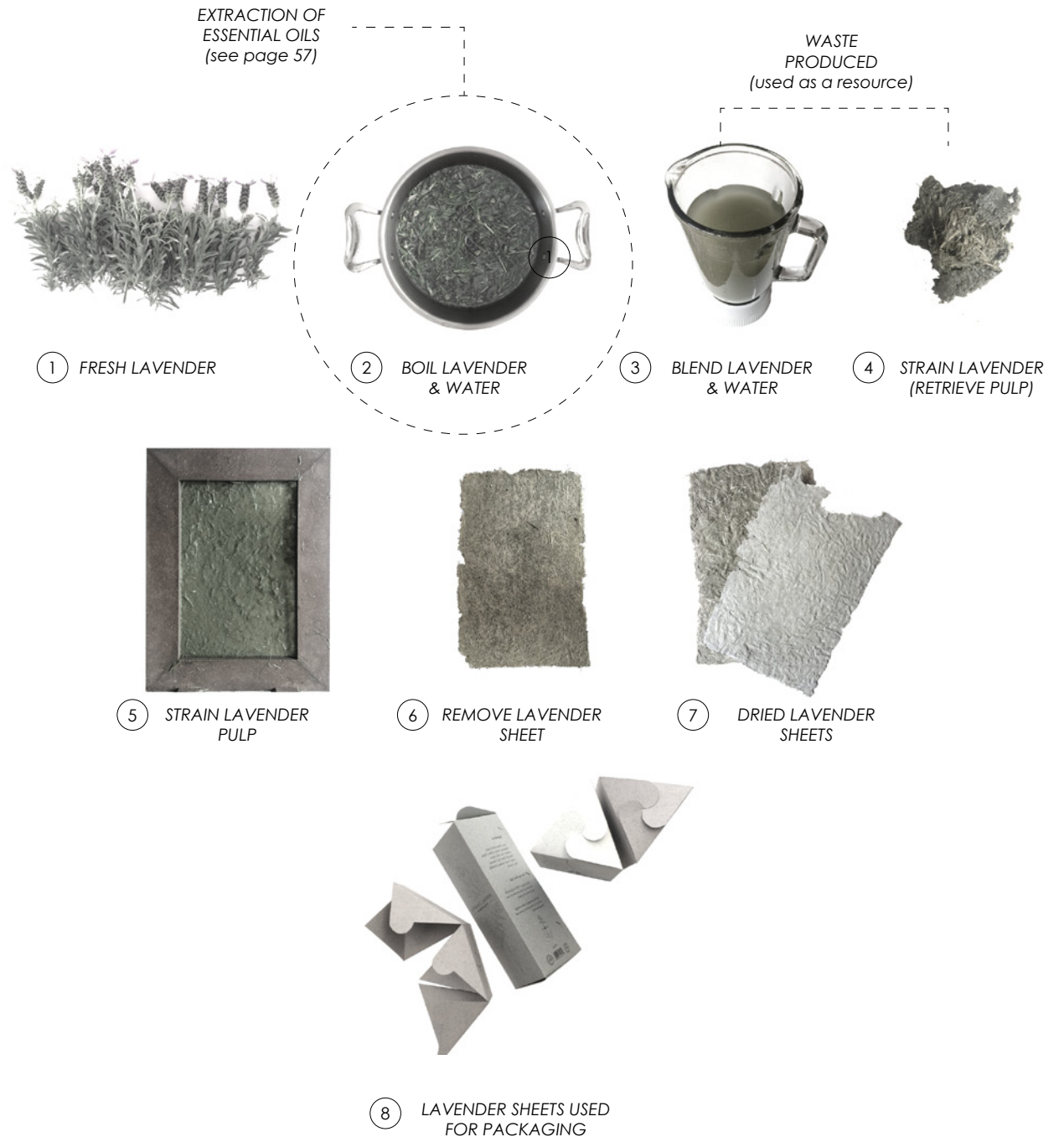

Figure 6.29. Lavender paper making process (Author, 2016).

6.1.3 ENERGY EFFICIENCY THROUGH EMULATION OF BIOMIMETIC PROCESSES

Shadow Study

A shadow study was carried out analyzing the movement of the sun during winter (June) and summer (December). The study showed that natural light does filter into the interior space through the large shopfront windows, and provides more exposure to sunlight in winter than in summer. It was also found that the natural light does not travel into the full-extended depth of the building, which is why provision for additional natural lighting/artificial lighting is required.

JUNE (Winter Solstice)



08:00



11:00



14:00

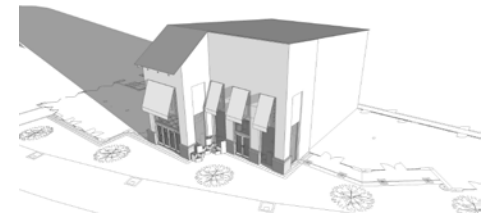

17:00

DECEMBER (Summer Solstice)

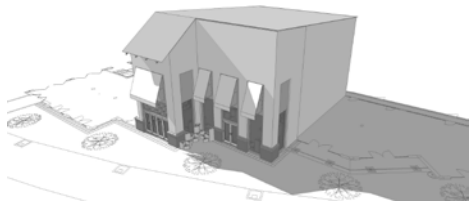

08:00



11:00

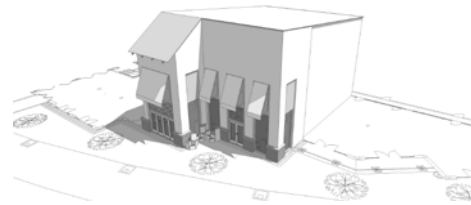

14:00

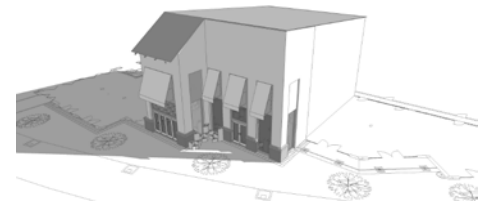

17:00

Figure 6.30. Shadow study (Author, 2016).

Passive Systems

The existing shell of Shop 150 allows for the design of passive systems, which emulates nature's processes as discussed in Chapter 2.

PASSIVE VENTILATION

The design and layout of the interior space was strategized in order to create a cross ventilation and stack ventilation effect that would ultimately draw fresh air from outside into the interior space and pull hot air out through the roof ventilators. A sloped ceiling forms part of this strategy, which will direct the flow of air towards the highest point of the roof structure (where hot air will naturally accumulate) towards a roof ventilator that will exhaust the hot air.

SOLAR ENERGY

Provision has been made for the installation of a photovoltaic solar panel, which will harvest energy from the sun to be used to supply power for interior activities..

DAYLIGHT

The design strategy also makes provision for solar tubes to be installed on the roof that will channel natural lighting into the interior space. These solar tubes reflect infrared radiation from the sun therefore it does not transmit any heat through the tubes. By introducing these solar tubes, the interior benefits from the advantages of natural light (as discussed in Chapter 2) and will reduce the quantity of artificial lighting required. It is important for the design of the suspended ceiling installation to be fitted in such a way as not to obstruct the natural light from entering the interior space.

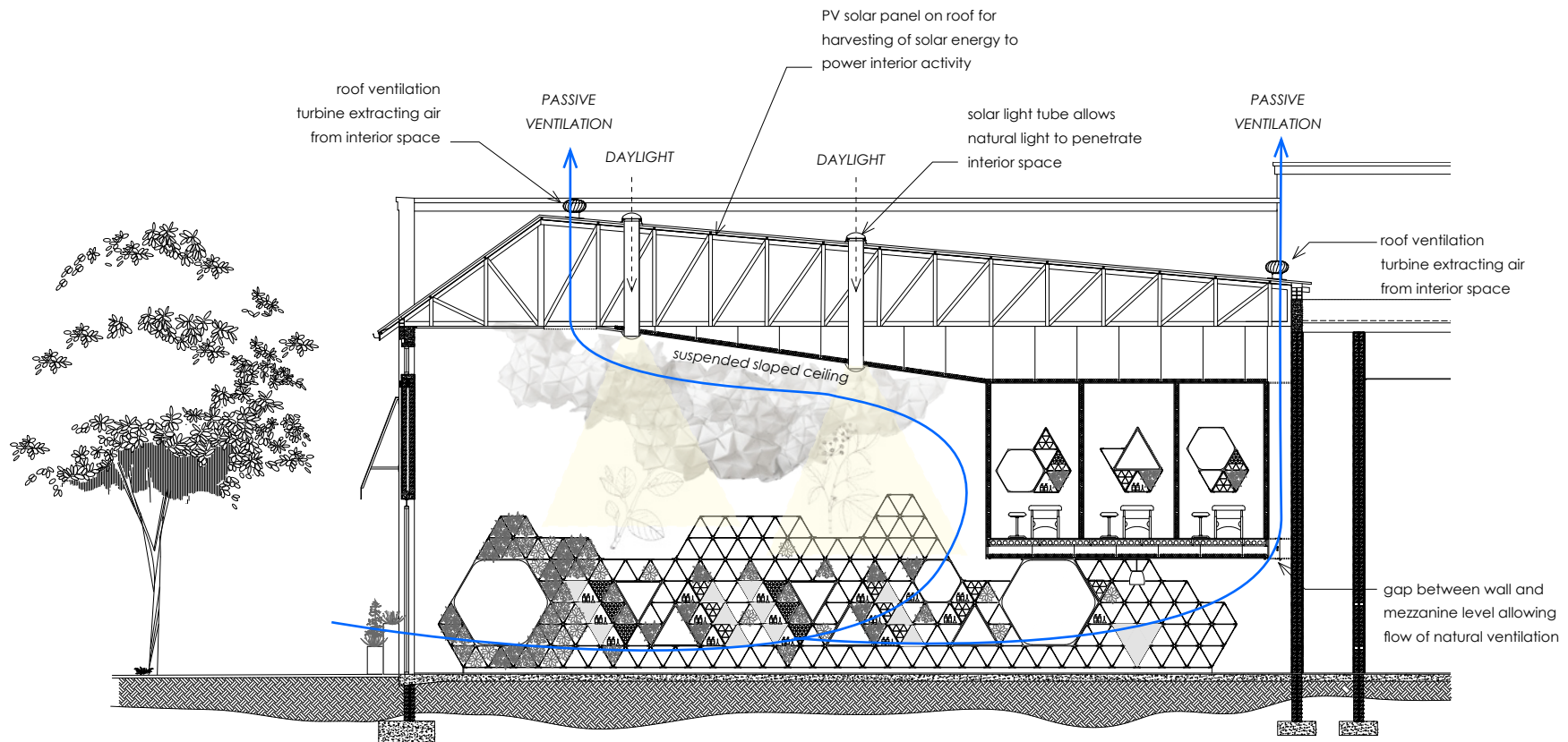

Figure 6.31. Diagram showing passive systems design (Author, 2016).

6.2 BIOPHILIC DESIGN APPLICATION

6.2.1 EXPERIENTIAL DESIGN STRATEGY OUTLINE

As previously discussed in Chapter 5, the experiential design strategy is influenced by the Biophilic design patterns (identified in Chapter 2). The design of Margaret Roberts' servicescape applies these patterns throughout the different retail zones with the aim of creating a rejuvenating and healing experience that mimics the atmospheric qualities of nature.

The application of Biophilic patterns in each of the different zones is summarized in Table 6.1 and will discuss a selection of zones in further depth throughout this chapter. Zone 12 (storage) is excluded from the experiential design strategy since it is not accessible to the public and does not contribute to the overall experience.

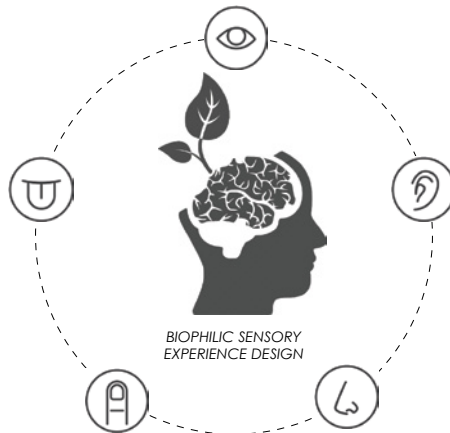
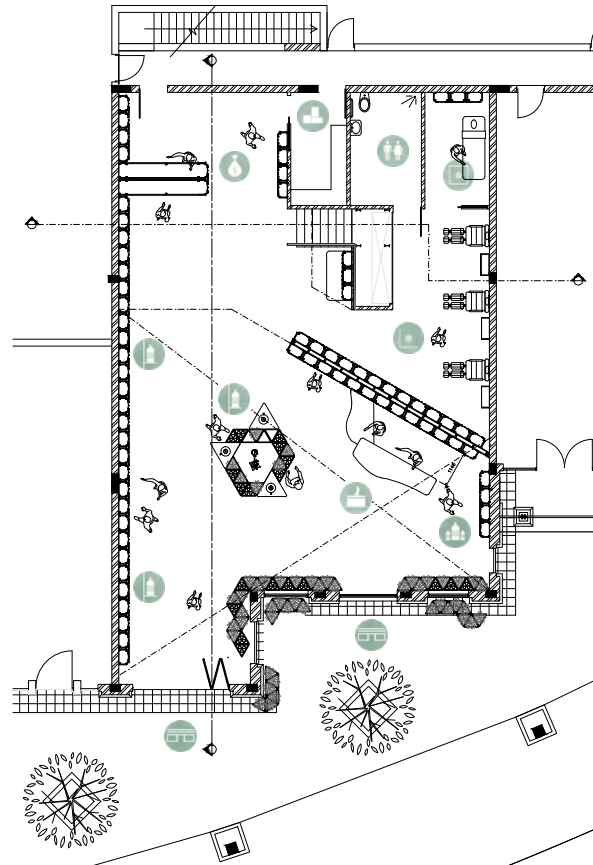

Figure 6.32. Biophilic sensory experience (Author, 2016).

GROUND FLOOR PLAN



MEZZANINE PLAN

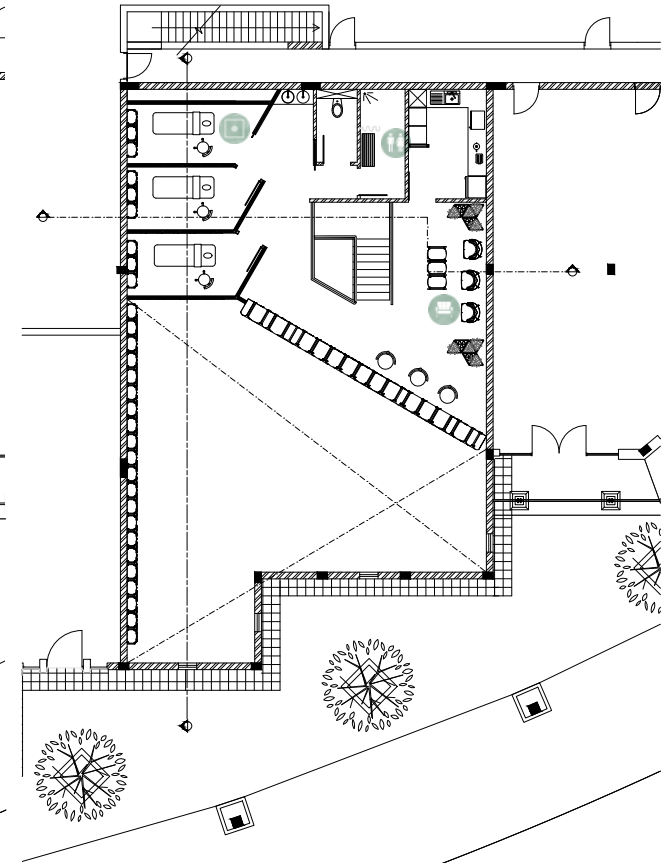

Figure 6.33. Diagram showing layout of retail zones for referral with Table 6.1 (Author, 2016).















					
 ZONE 1: FACADE / ENTRANCE	<ul style="list-style-type: none"> > [P1] Trees and herbal plants outside entrance creates visual connection with nature > [P6] Natural light filtering into store 	<ul style="list-style-type: none"> > [P2] Rustling of leaves and birds chirping heard outside store creates calming atmosphere 	<ul style="list-style-type: none"> > [P2] Plants displayed outside store can be touched creating a tactile connection with nature > [P4] Natural airflow outside store 	<ul style="list-style-type: none"> > [P2] Plants outside store give off fresh scents 	N/A
 ZONE 2: VERTICAL DISPLAY	<ul style="list-style-type: none"> > [P1] Plants within display creates visual connection with nature > [P6] Natural light illuminating display > [P8] Display resembles biomorphic forms and patterns > [P10] Complexity and order of display creates visual interest 	<ul style="list-style-type: none"> > [P2] Close proximity to exterior therefore allowing auditory connection with nature outside store > [P2] Soothing background music with nature sounds played in retail section creating a relaxing shopping experience 	<ul style="list-style-type: none"> > [P2] Plants within display can be touched creating a tactile connection with nature > [P4] Natural airflow through passive ventilation system 	<ul style="list-style-type: none"> > [P2] Plants within vertical display give off fresh scents > [P2] Scent from essential oil distillation inside store diffuses throughout the retail section creating an olfactory connection with nature 	N/A
 ZONE 3: FLOOR DISPLAY	<ul style="list-style-type: none"> > [P10] Complexity and order of display creates visual interest > [P1] Plants within display creates visual connection with nature > [P8] Display resembles biomorphic forms and patterns 	<ul style="list-style-type: none"> > [P2] Close proximity to exterior therefore allowing auditory connection with nature outside store > [P2] Soothing background music with nature sounds played in retail section creating a relaxing shopping experience 	<ul style="list-style-type: none"> > [P2] Plants within display can be touched creating a tactile connection with nature > [P4] Natural airflow through passive ventilation system > [P9] Natural materials creates material connection with nature 	<ul style="list-style-type: none"> > [P2] Plants within floor display give off fresh scents > [P2] Scent from essential oil distillation inside store diffuses throughout the retail section creating an olfactory connection with nature 	N/A
 ZONE 3: PRODUCT TESTING	<ul style="list-style-type: none"> > [P1] Plants within display creates visual connection with nature > [P8] Display resembles biomorphic forms and patterns 	<ul style="list-style-type: none"> > [P2] Soothing background music with nature sounds played in retail section creating a relaxing shopping experience 	<ul style="list-style-type: none"> > [P4] Natural airflow through passive ventilation system > [P9] Natural materials creates material connection with nature 	<ul style="list-style-type: none"> > [P2] Scent from essential oil distillation inside store diffuses throughout the retail section creating an olfactory connection with nature 	N/A
 ZONE 5: SKIN BAR	<ul style="list-style-type: none"> > [P8] Counter design resembles biomorphic forms and patterns > [P10] Complexity and order of display behind skin bar creates visual interest 	<ul style="list-style-type: none"> > [P2] Soothing background music with nature sounds played in retail section creating a relaxing shopping experience 	<ul style="list-style-type: none"> > [P4] Natural airflow through passive ventilation system > [P9] Natural materials creates material connection with nature 	<ul style="list-style-type: none"> > [P2] Plants within POS display give off fresh scents > [P2] Scent from essential oil distillation inside store diffuses throughout the retail section creating an olfactory connection with nature 	N/A
 ZONE 6: POS / RECEPTION	<ul style="list-style-type: none"> > [P1] Plants within POS display creates visual connection with nature > [P8] Counter design resembles biomorphic forms and patterns > [P10] Complexity and order of display next to POS creates visual interest 	<ul style="list-style-type: none"> > [P2] Soothing background music with nature sounds played in retail section creating a relaxing shopping experience 	<ul style="list-style-type: none"> > [P2] Plants within display can be touched creating a tactile connection with nature > [P4] Natural airflow through passive ventilation system > [P9] Natural materials creates material connection with nature 	<ul style="list-style-type: none"> > [P2] Scent from essential oil distillation inside store diffuses throughout the retail section creating an olfactory connection with nature 	N/A
 ZONE 7: WAITING AREA	<ul style="list-style-type: none"> > [P1] Pot plants in waiting area creates visual connection with nature > [P6] Natural light illuminating seating area 	<ul style="list-style-type: none"> > [P2] Soothing background music with nature sounds played in waiting area creating a relaxing shopping experience 	<ul style="list-style-type: none"> > [P2] Plants within display can be touched creating a tactile connection with nature > [P9] Natural materials creates material connection with nature 	<ul style="list-style-type: none"> > [P2] Pot plants in waiting area give off fresh scents 	<ul style="list-style-type: none"> > [P2] Non-visual connection with nature (gustatory) created by serving clients with food and drinks with natural and fresh ingredients
 ZONE 8: SEMI-PRIVATE TREATMENT	<ul style="list-style-type: none"> > [P1] Vertical plants creates visual connection with nature > [P8] Display resembles biomorphic forms and patterns 	<ul style="list-style-type: none"> > [P2] Therapeutic nature sounds played in semi-private treatment area 	<ul style="list-style-type: none"> > [P2] Plants within display can be touched creating a tactile connection with nature > [P9] Natural materials creates material connection with nature 	<ul style="list-style-type: none"> > [P2] Plants within vertical display give off fresh scents 	N/A
 ZONE 9: PRIVATE TREATMENT	<ul style="list-style-type: none"> > [P1] Vertical plants creates visual connection with nature > [P8] Display resembles biomorphic forms and patterns 	<ul style="list-style-type: none"> > [P2] Therapeutic nature sounds played in private treatment area 	<ul style="list-style-type: none"> > [P2] Plants within display can be touched creating a tactile connection with nature > [P9] Natural materials creates material connection with nature 	<ul style="list-style-type: none"> > [P2] Plants within vertical display give off fresh scents 	N/A
 ZONE 11: ABLUTION	<ul style="list-style-type: none"> > [P1] Pot plants to be used in ablution facilities to create visual connection with nature 	<ul style="list-style-type: none"> > [P2] Soothing background music with nature sounds played in bathroom/ changing facilities 	N/A	<ul style="list-style-type: none"> > [P2] Pot plants in ablution facilities to give off fresh scent to help mask unpleasant odours 	N/A

Table 6.1. Summary of biophilic patterns application towards experiential design (Author, 2016).



ZONE 01

Entrance / Facade

The design of the shopfront (Zone 1) is the starting point for the consumer experience and essentially aims to soften the threshold between the exterior and interior of the shop to make people feel comfortable to enter the space. Pot plants containing medicinal herbs associated with Margaret Roberts' skincare products are displayed outside the shopfront to create a visual, tactile and olfactory connection with nature. These pot plants filter into the entrance of the space, essentially blurring the lines between the exterior and interior of the shop.

Branding is included on the awnings that frame the window displays. Branding is also included within the window displays themselves, which provides a glimpse of the products provided in the store – hopefully just enough to catch attention and to entice customers to enter the store.

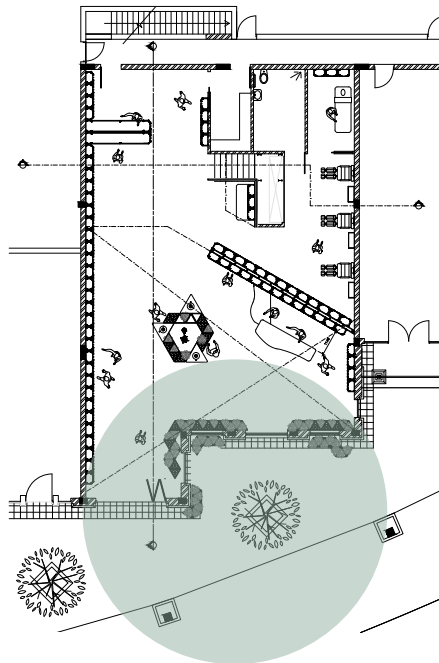

Figure 6.34. Diagram showing zoning of facade (Author, 2016).

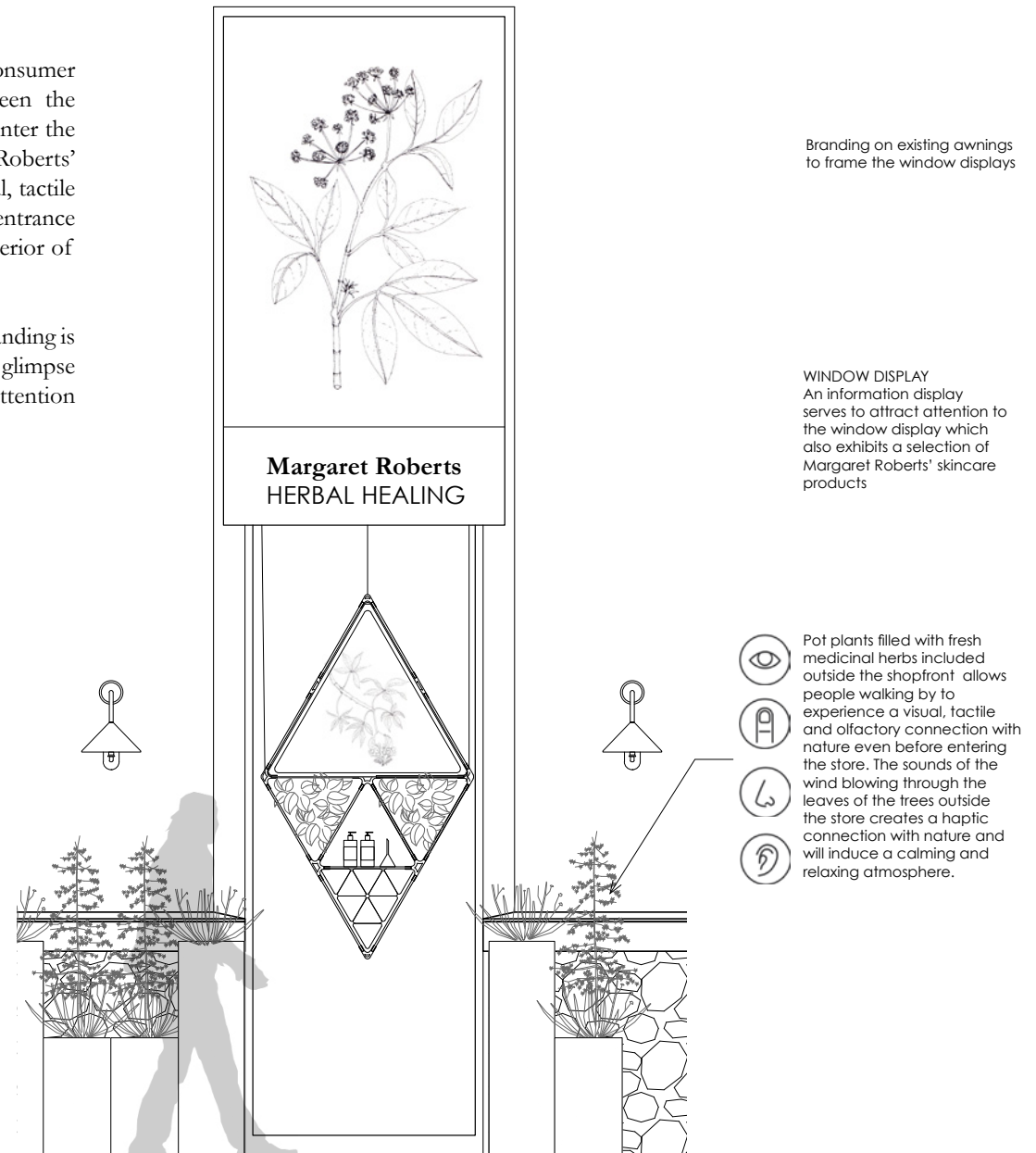

Figure 6.35. Window display design (Author, 2016).





Margaret Roberts
HERBAL HEALING

Margaret Roberts
HERBAL HEALING

Margaret Roberts
ESSENTIAL OILS

Margaret Roberts
MEDICINE CREAMS

Margaret Roberts
GENERAL CREAMS

Margaret Roberts
RESQUE SALTS

Margaret Roberts
HERBAL HEALING





ZONE 03

Floor Display

The design of the floor display showcases the essential oil distillation process, allowing clients to see the authentic nature behind the creation of Margaret Roberts' skincare products. Herbal plants and skincare products are displayed around the distillation process to encourage clients to "pick" skincare from the display - mimicking the process of picking medicinal herbs. The display also includes 3 'replenish stations' that allows clients to refill their empty skincare bottles with essential oils to promote recycling.

This zone contributes to the overall rejuvenation experience within the retail space through creating a visual, tactile and olfactory connection with nature.

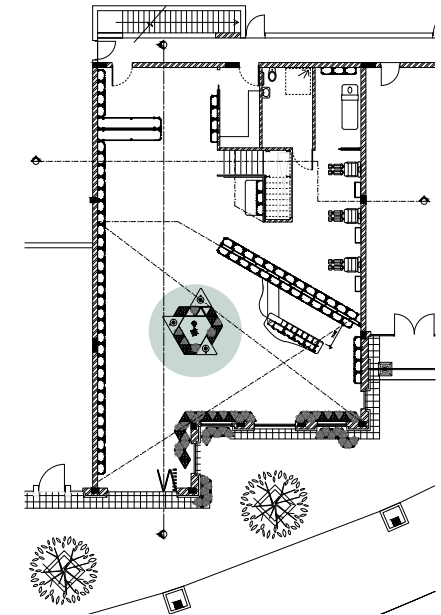

Figure 6.38. Diagram showing zoning of floor display area (Author, 2016).

Precedent Study : Laboratory Glassware (Aesop)

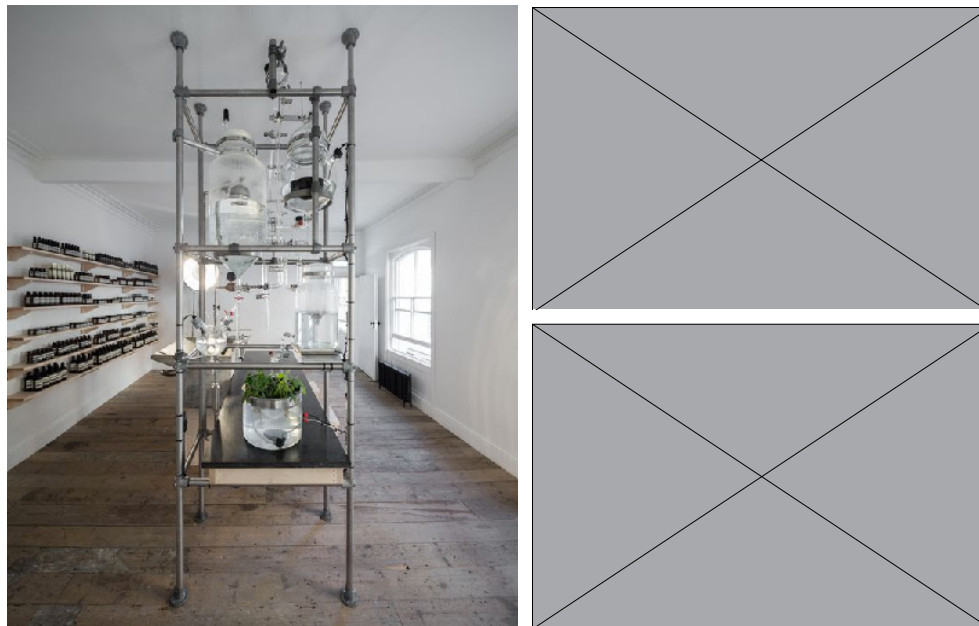

Figure 6.39. Precedent Study: Aesop laboratory glassware in store design (Aesop, 2016).

Aesop

Many of Aesop store designs include the use of laboratory glassware that carry out various functions within the interior space. For instance, custom made laboratory-inspired glassware has been used to create taps and water dispensers in Aesop stores, which creates a scientific association with the brand.

This precedent study shows how the use of laboratory glassware and equipment can be successfully used in the design of Margaret Roberts' skincare servicescape.





ZONE 05

Skin Bar

The Skin Bar is a designated area where clients can consult with skincare professionals regarding the product range best suited for their skin type. The design of this zone also relies on the same 'kit of parts' used to construct the vertical display system and therefore offers similar experiential qualities.

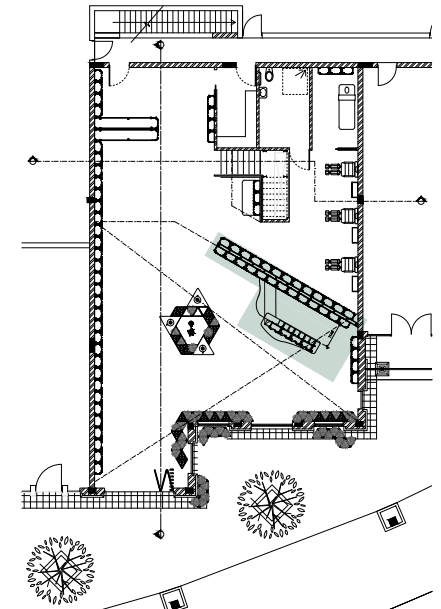
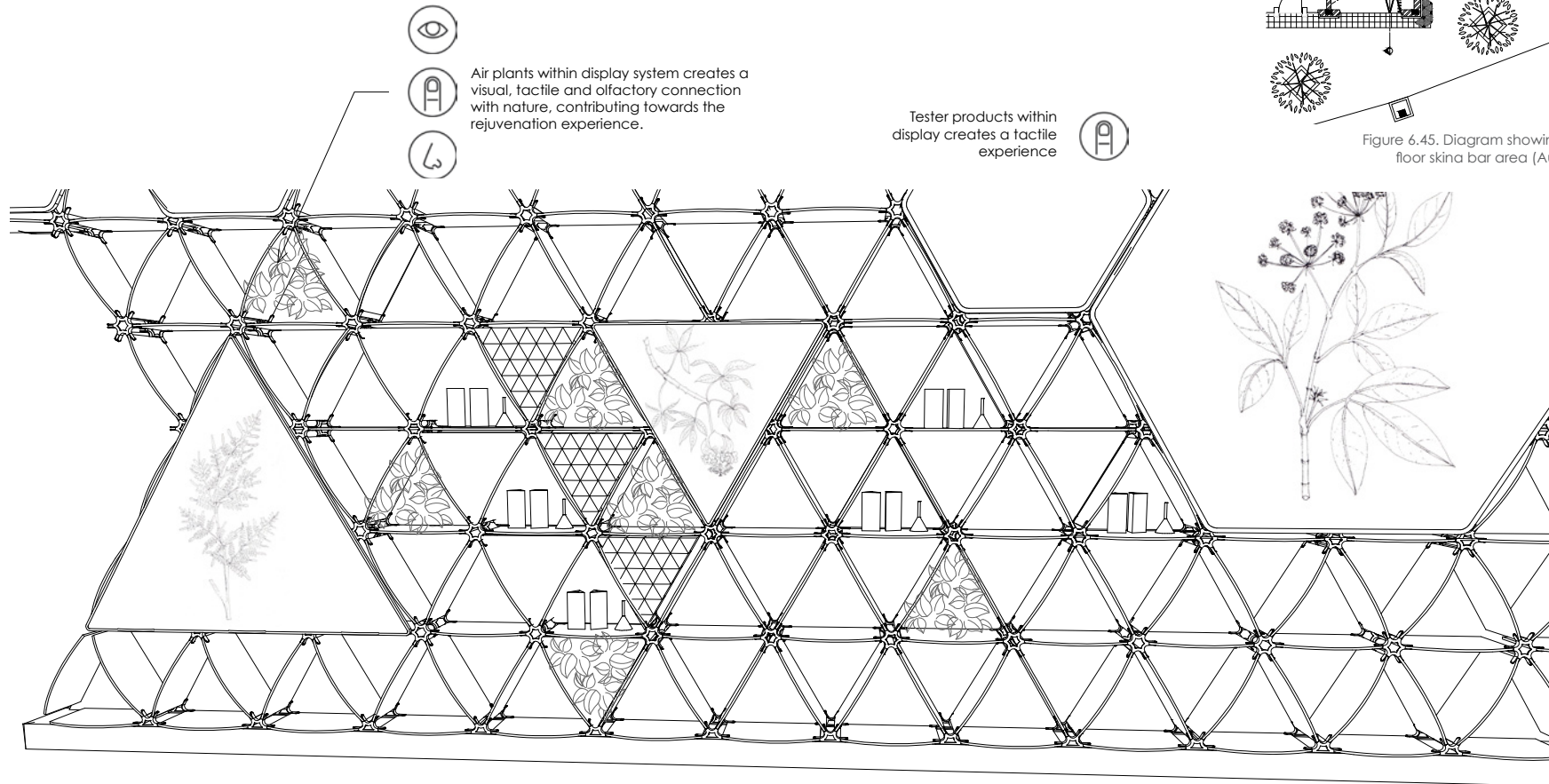
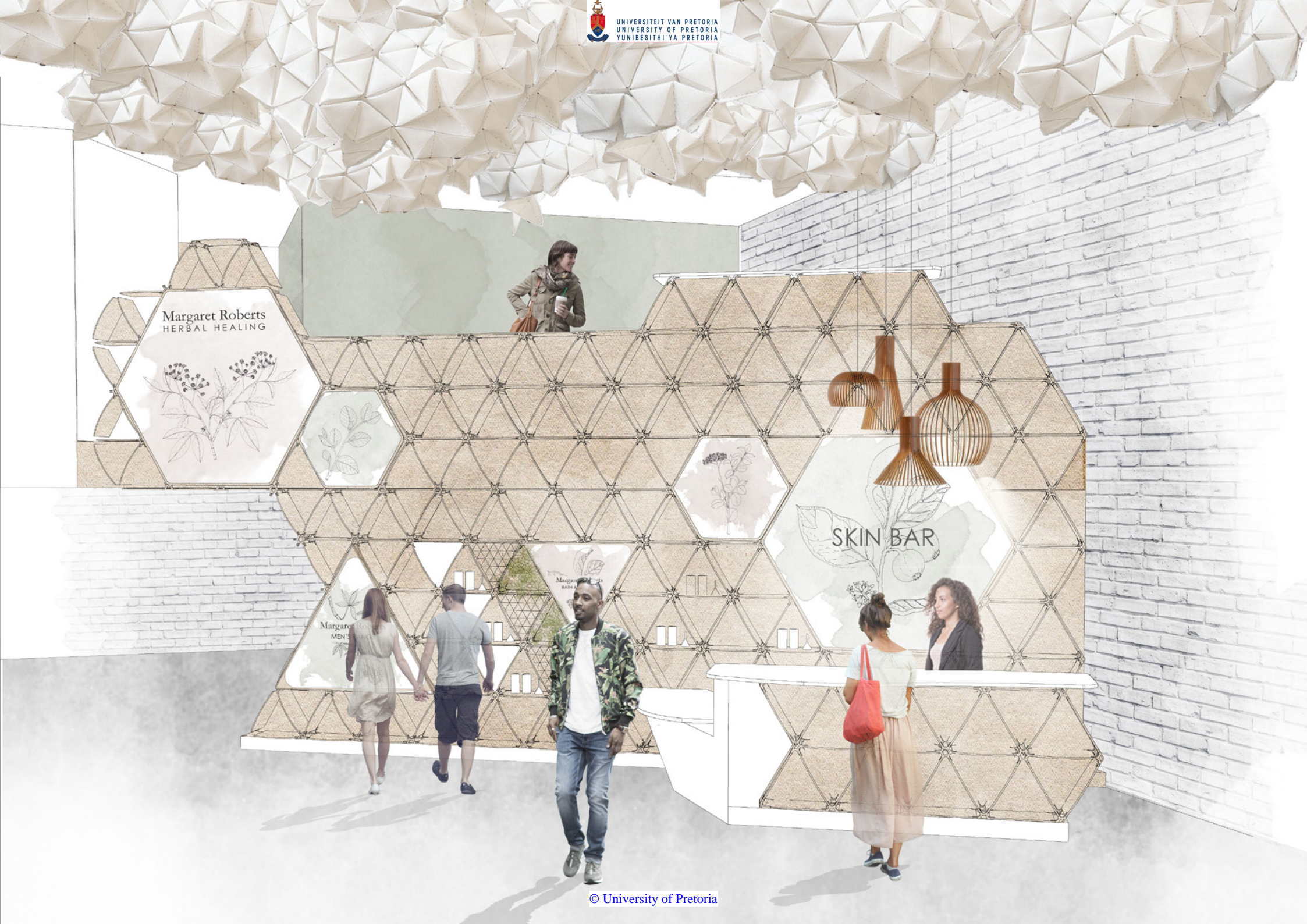

Figure 6.45. Diagram showing zoning of floor skina bar area (Author, 2016).

Figure 6.46. Call out of vertical display design behind Skin Bar (Author, 2016).





ZONE 06

POS/ Reception Area

Zone 6 combines the Point of Sale and Reception area into one, and marks the end of the 'retail experience' and the beginning of the 'service experience' in Margaret Roberts servicescape. The point of sale/reception area was positioned near the back of the store to force customers to walk through the whole interior space before completing a purchase. The counter has been designed as an extrusion of the vertical display system to remain with the concept of one unified structure.

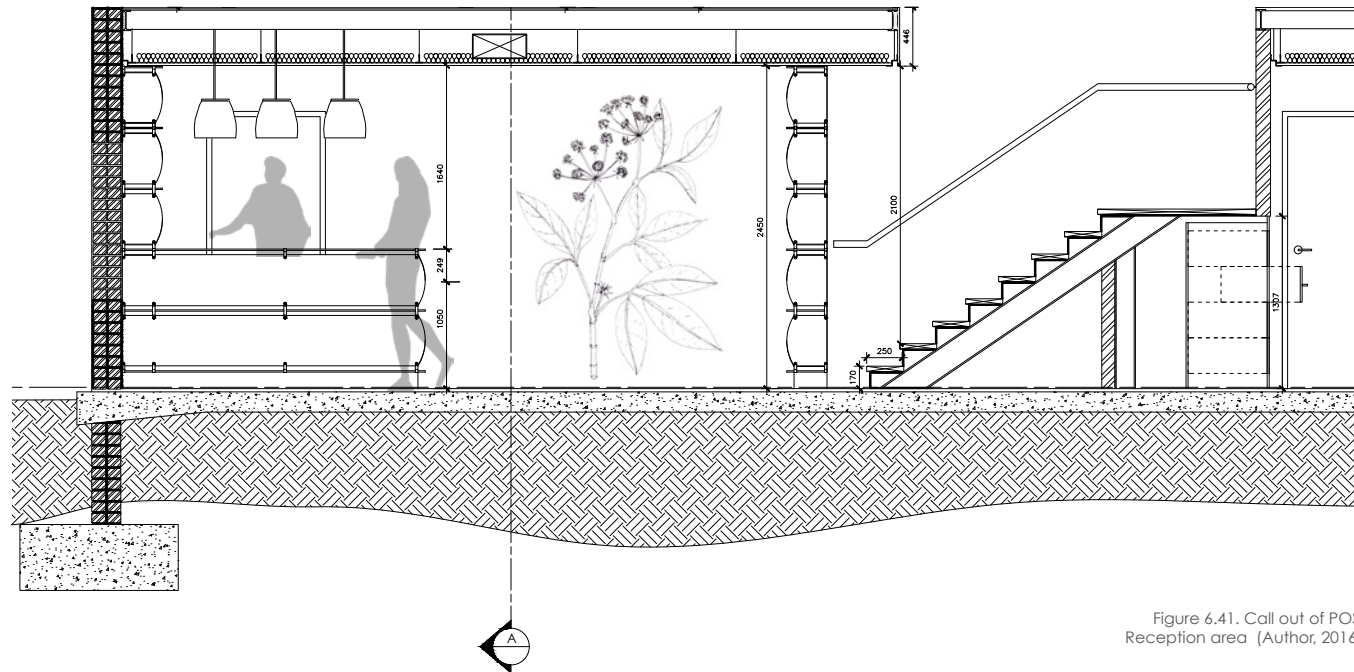

Figure 6.41. Call out of POS/ Reception area (Author, 2016).

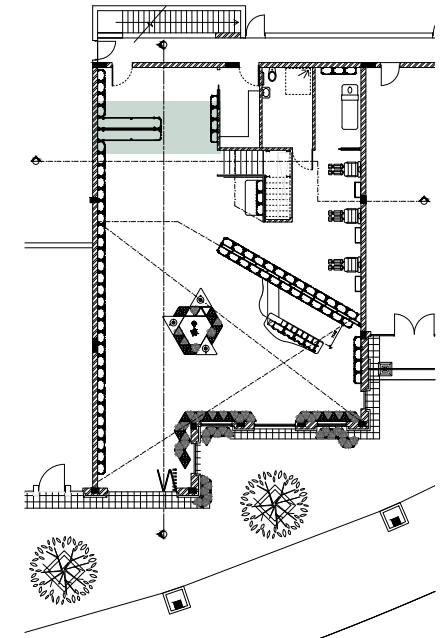

Figure 6.40. Diagram showing zoning of POS/Reception area (Author, 2016).



Margaret Roberts
HERBAL HEALING

PLEASE PAY HERE

EMERGENCY
EXIT

Margaret Roberts
TISSUE SALTS

6.3 SPATIAL LAYOUT DESIGN

6.3.1 FLOOR PLAN LAYOUT_ITERATION 1

Model building was used as a method for design exploration of spatial layouts. The initial spatial layout was governed by the dynamic lines and shapes to reflect the characteristics of a triangulated design; but later evolved to a much more simplified and structured spatial layout as seen in the final design.

It was important for the spatial configuration to consider the circulation through the space and to ensure access from the mezzanine is within close proximity to the existing fire escape located at the back of the site. Due to required access to the service alley, it was also necessary for the storage space and ablution facilities to be located near the back wall.

The design introduced a mezzanine structure into the rear end of the retail space to allocate a private area for treatment services.

The first iteration of spatial layout design did not prove to be an effective design solution since the retail space was not utilized to its best potential.

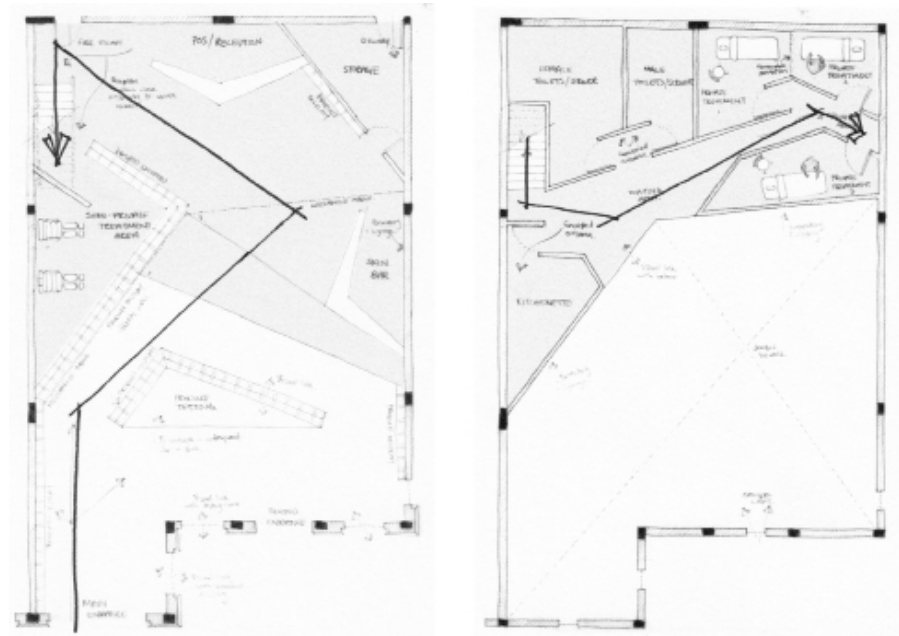

Figure 6.42. Diagram of circulation through space of Spatial Layout Iteration 1 (Author, 2016).



Figure 6.43. Spatial layout design iteration 1 (Author, 2016).

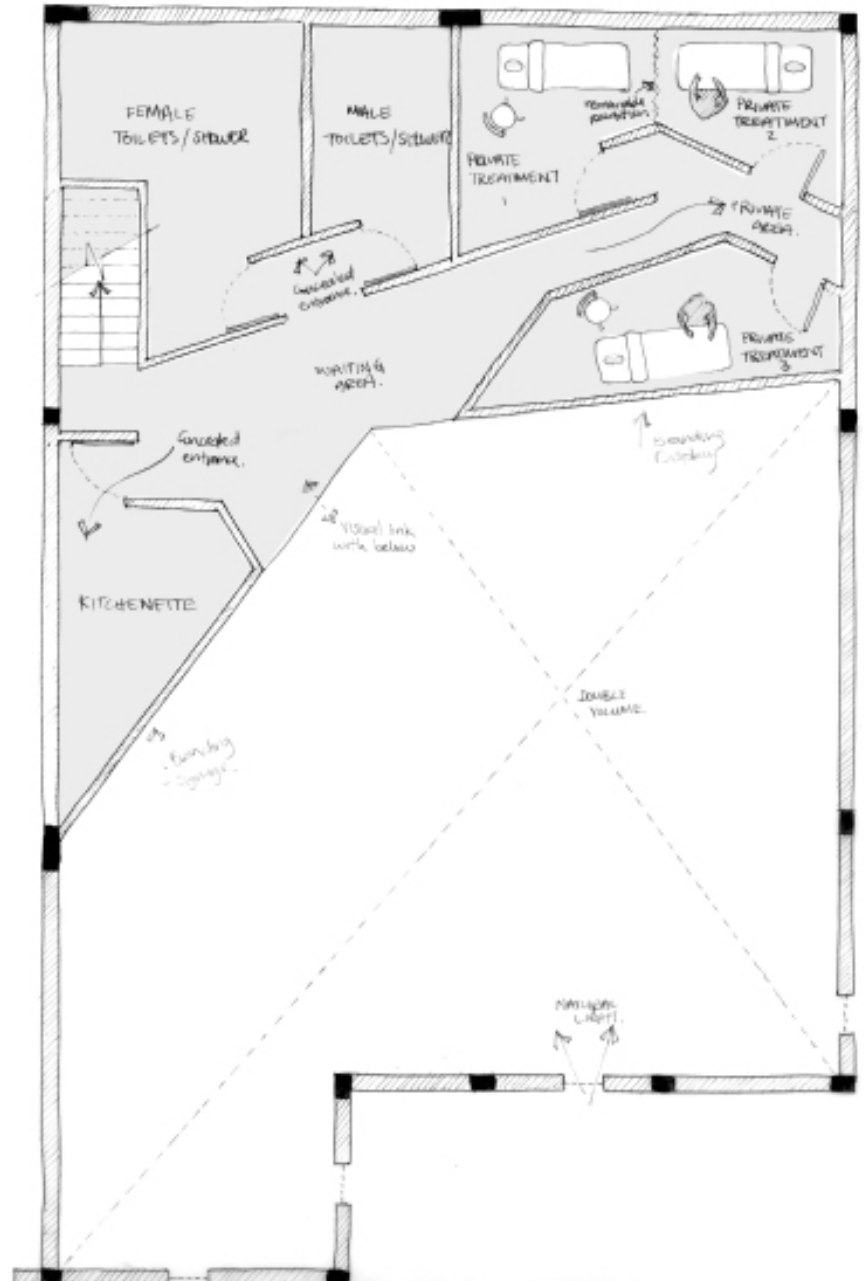
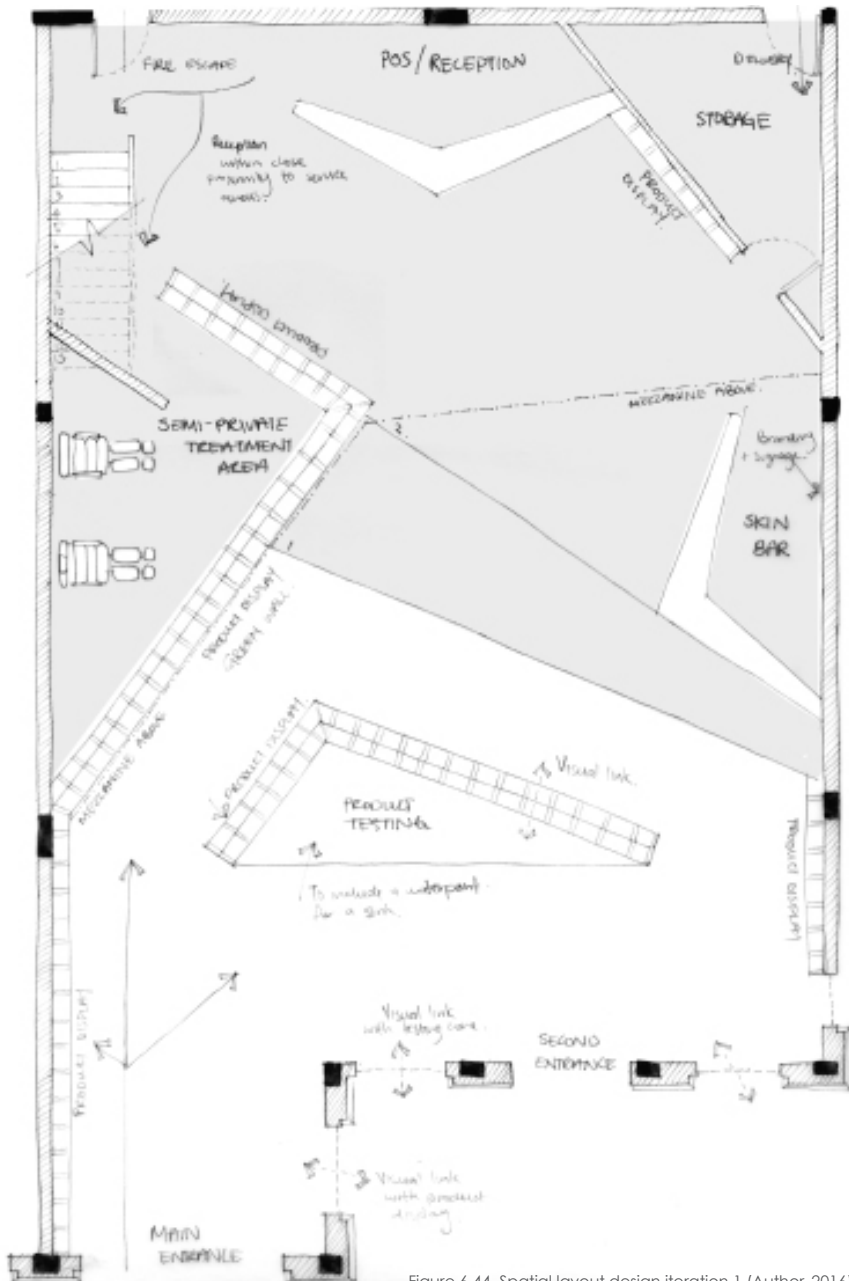

Figure 6.44. Spatial layout design iteration 1 (Author, 2016).

6.3.2 FLOOR PLAN LAYOUT _ ITERATION 2

The second iteration of spatial layouts also employed the use of dynamic lines and shapes to section off the zones and attempted to utilize the retail space more efficiently. However, the use of these dynamic lines in both the first and second iteration proved to be problematic and was therefore discarded and not applied in the final layout design.

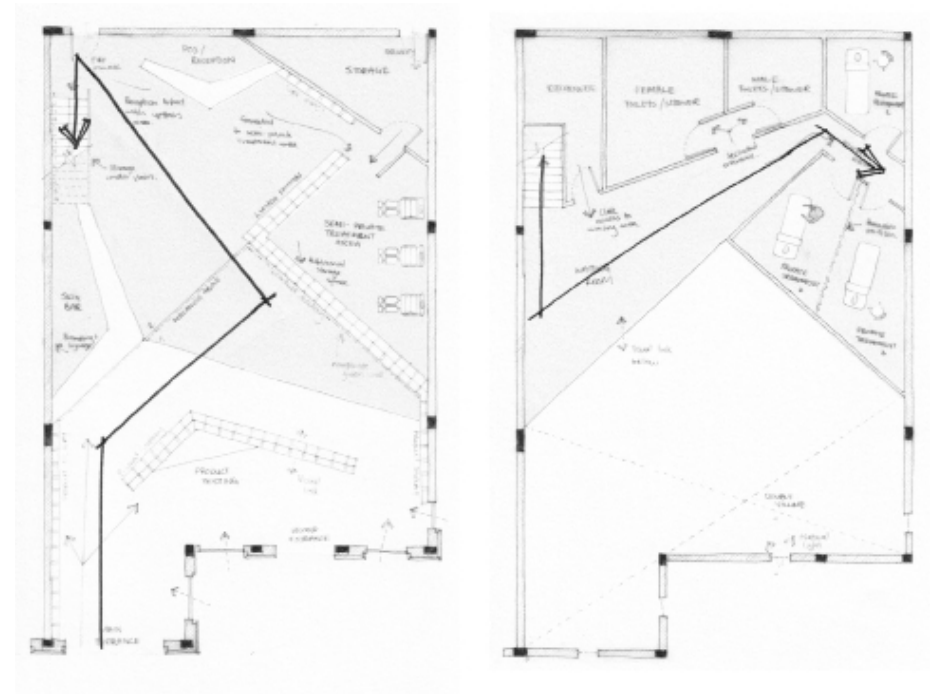

Figure 6.45. Spatial layout design iteration 2 (Author, 2016).

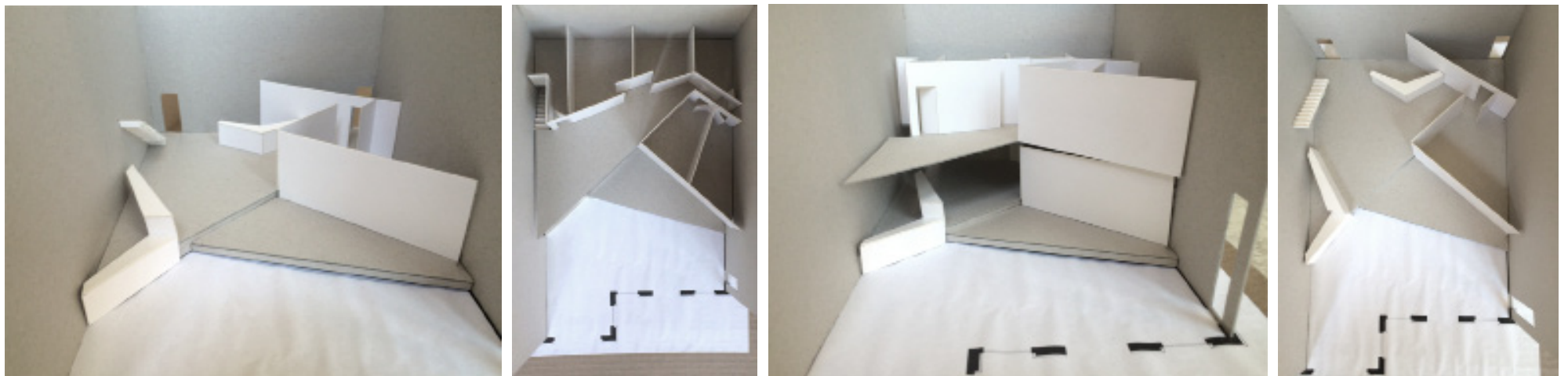

Figure 6.46. Spatial layout design iteration 2 (Author, 2016).

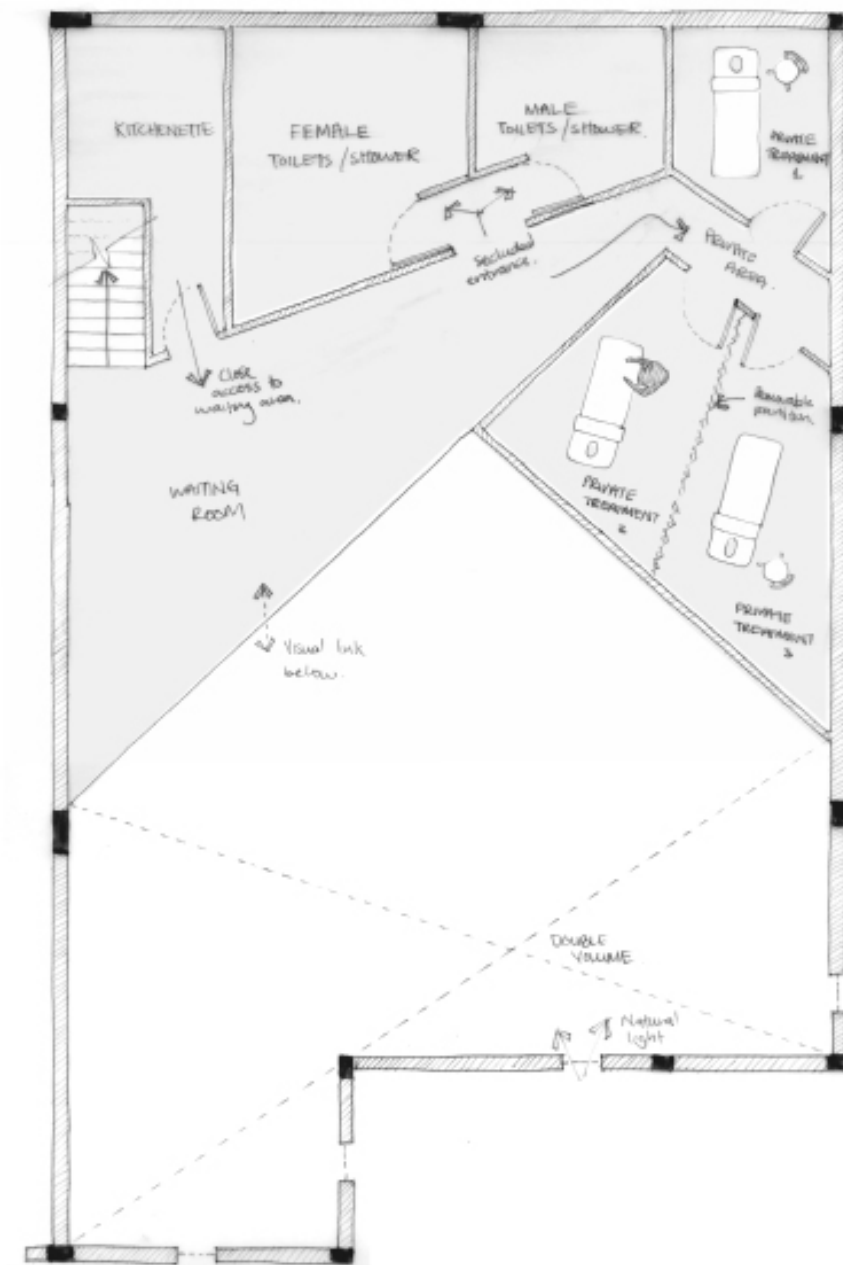
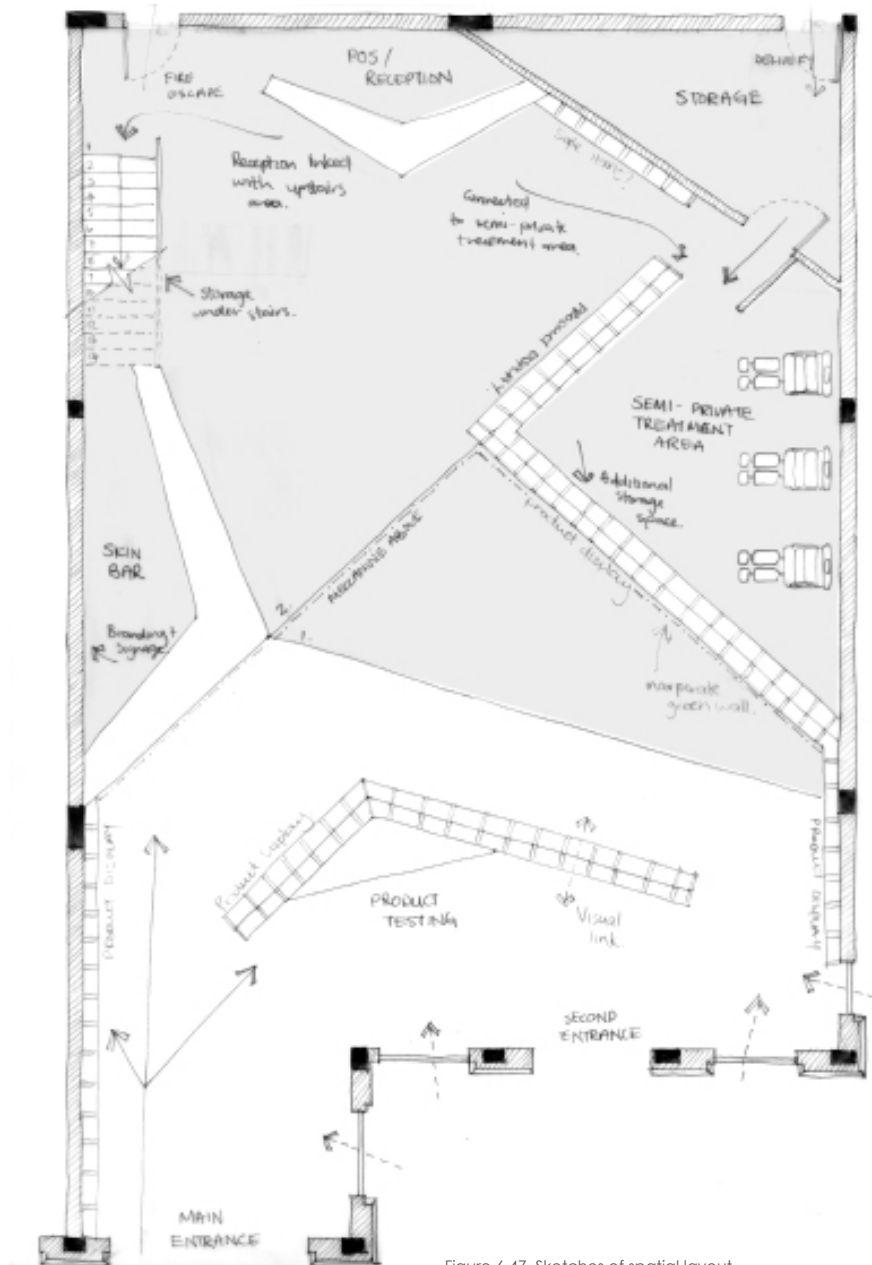
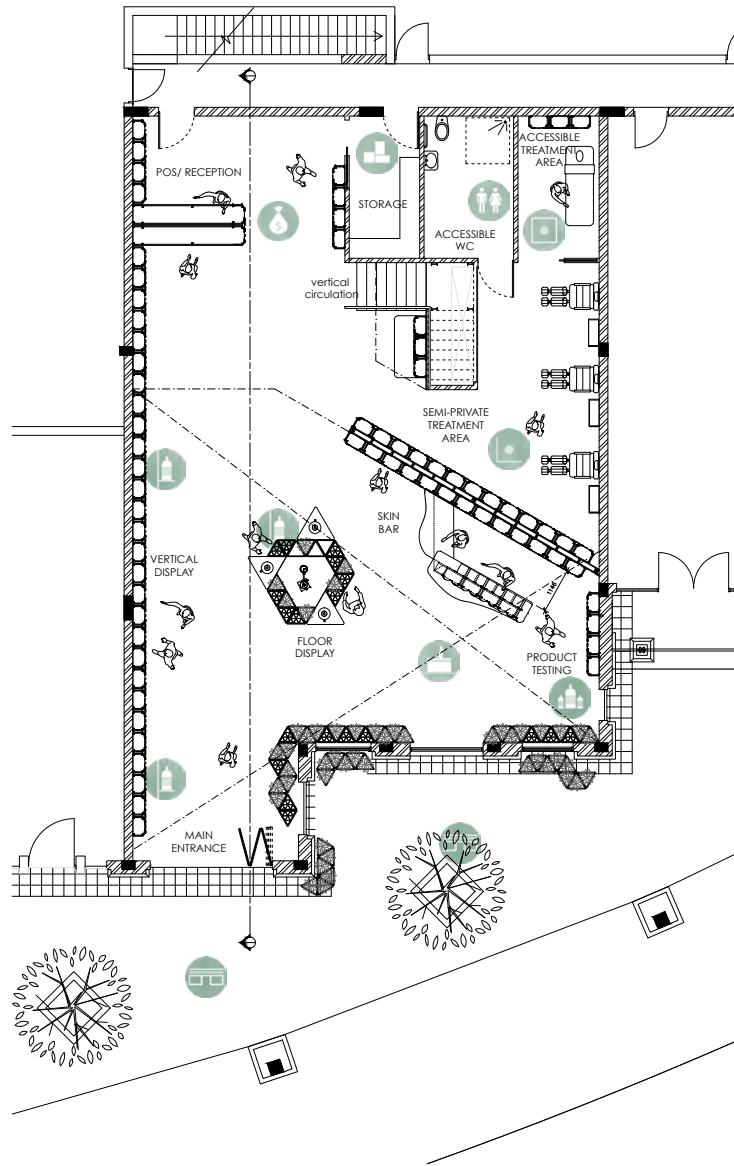

Figure 6.47. Sketches of spatial layout design iteration 2 (Author, 2016).

6.3.3 FINAL FLOOR PLAN LAYOUT

-  FACADE
-  VERTICAL DISPLAY
-  FLOOR DISPLAY
-  PRODUCT TESTING AREA
-  SKIN BAR
-  POS/ RECEPTION
-  WAITING AREA
-  SEMI-PRIVATE TREATMENT
-  PRIVATE TREATMENT
-  ABLUTION
-  STORAGE
-  KITCHENETTE



GROUND FLOOR PLAN
not to scale

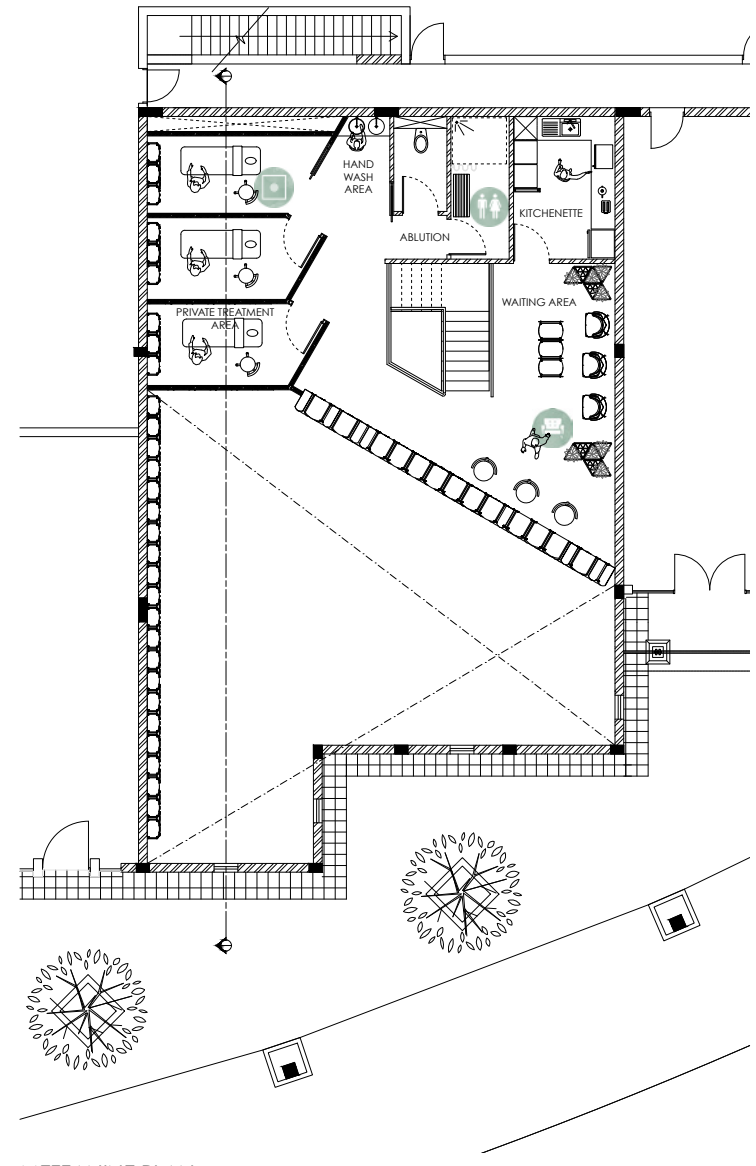

MEZZANINE PLAN
not to scale

Figure 6.48. Iterated Ground Floor and Mezzanine Plans (Author, 2016).

6.3.4 SECTION A-A

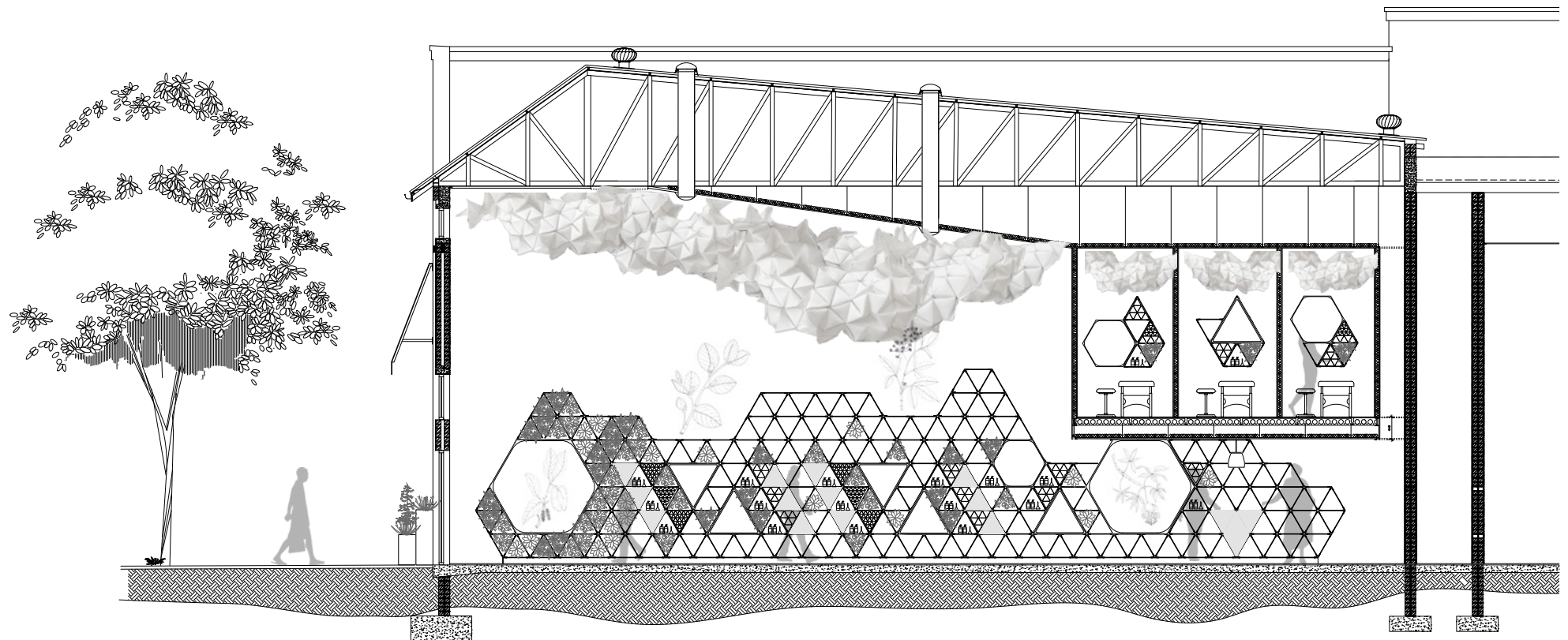

SECTION A-A
not to scale

Figure 6.49. Section A-A
Design(Author, 2016).



TECHNICAL INVESTIGATION

EMULATE

This chapter deals with the technical development of the design, focusing specifically on the detailing of the triangulated display system. Further investigations into acoustics, artificial lighting and passive systems will be presented in the final exam

07

7.1 FLOOR PLANS

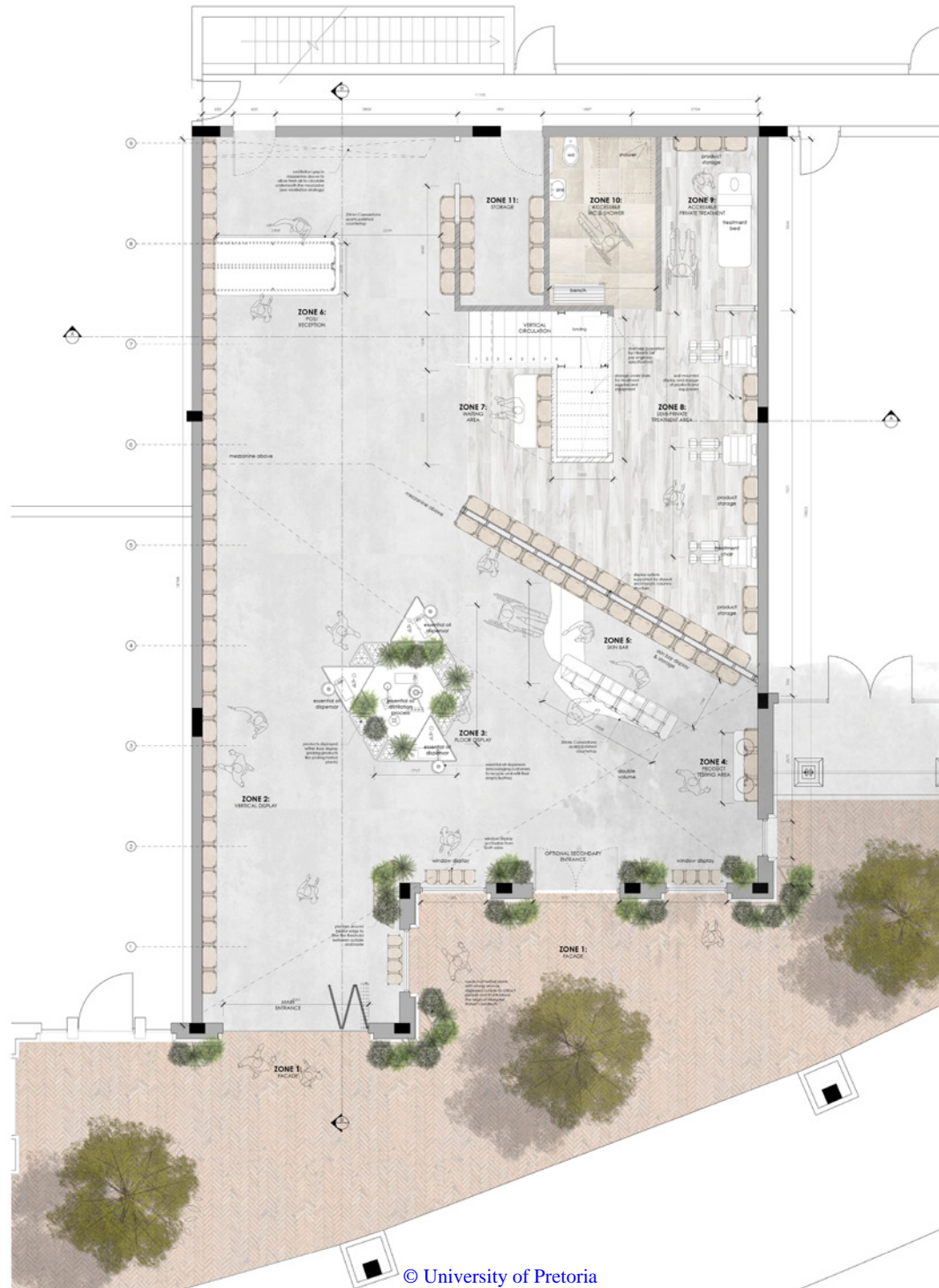

Figure 7.1. Iterated Ground Floor Plan (Author, 2016)

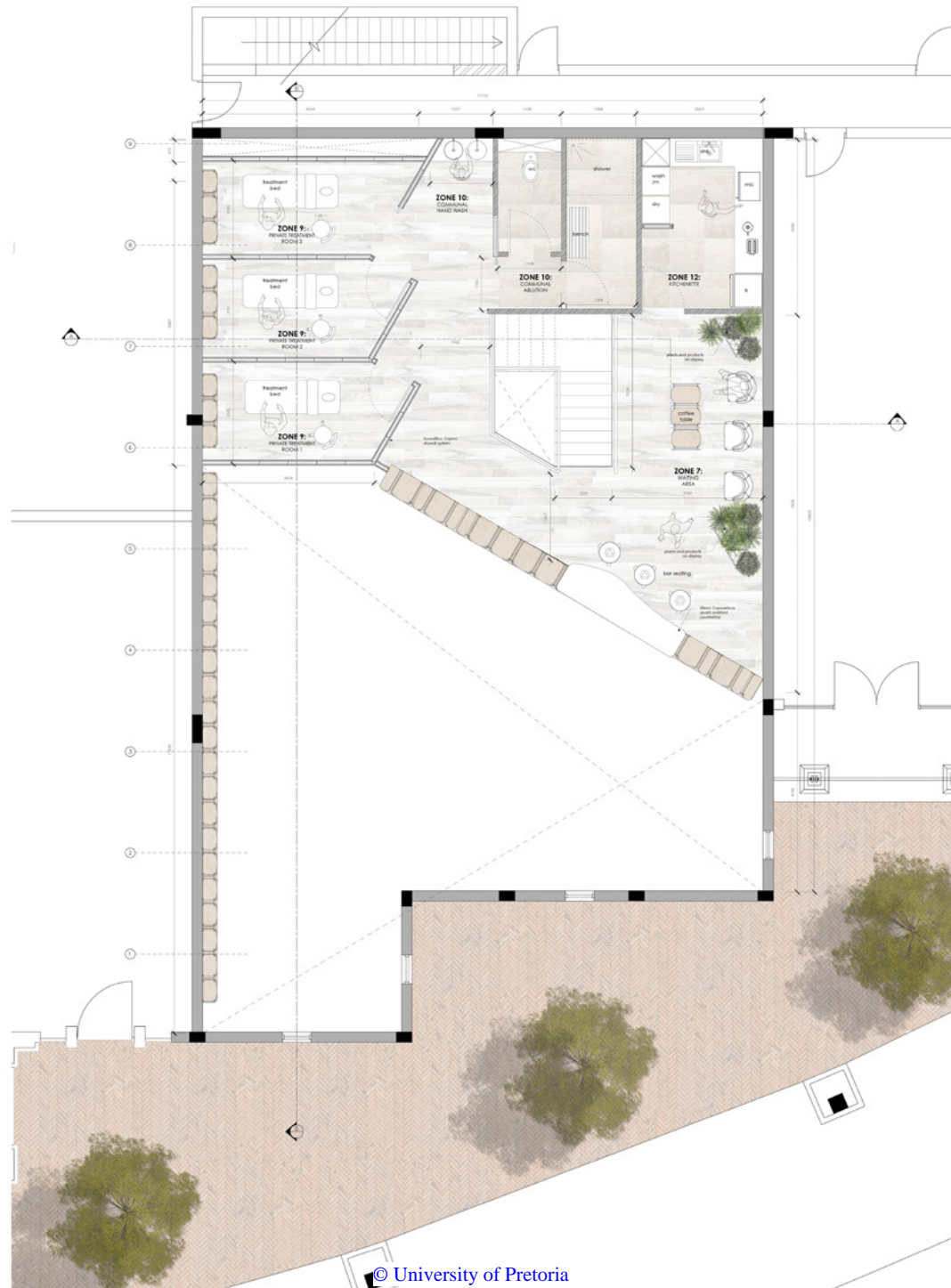

Figure 7.2. Iterated Mezzanine Plan
(Author, 2016).



Figure 7.3. Facade Design (Author, 2016)



Figure 7.4 Iterated Section A-A showing relationship between zones (Author, 2016)

SECTION A-A
not to scale



SECTION B-B
not to scale

Figure 7.5. Iterated Section B-B showing vertical display (Author, 2016)



Figure 7.6 Perspective of Entrance
(Author, 2016)

FLOOR PLANTER DESIGN

- 1 Medicinal Herbs (as specified by Margaret Roberts)
- 2 3D Printed Planting base container
- 3 Organic fibre composite shell

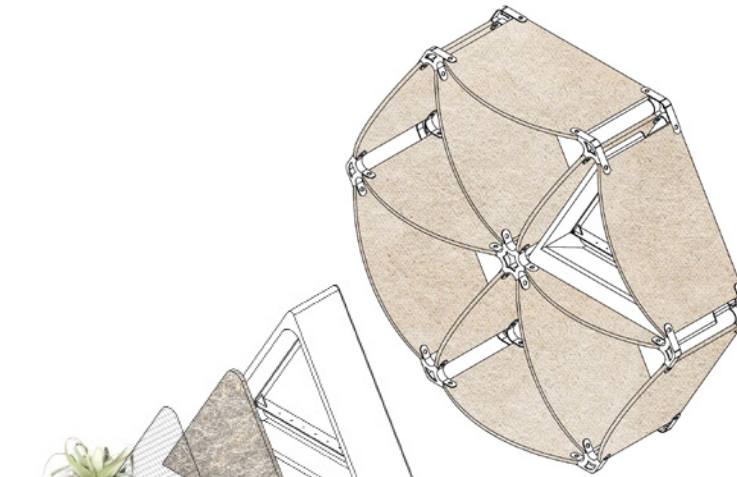

- 1 Air plants inserted into the vertical display
- 2 3D Printed Planting base container
- 3 Coconut husk felt kept moist to provide moisture to the plants
- 4 Wire mesh for plants to attach to



Figure 7.7. Air plants planting strategy (Author, 2016).



Figure 7.7. Perspective of point of view from Mezzanine (Author, 2016).

7.2 MATERIAL PALETTE



MATERIAL TEXTURE	MATERIAL SPECIFICATION	APPLICATION	DESIGN REQUIREMENTS	PROPERTIES	SOURCING	ENVIRONMENTAL IMPACT
FLOOR FINISH						
	POWER FLOATED SCREED FLOOR > Retail floor space Existing: 120mm power floated screed floor sealed with floor guard	GROUND FLOOR > Retail floor space	> The screed floor offers a smooth and natural finish to the retail space.	> Water resistant coating > Durable coating > Raw and natural finish	EXISTING	> Re-using existing flooring reduces material consumption and has no environmental impact
	LAMINATE TIMBER FLOOR EchoWood Deluxe Click Vinyl (Beech Sand Colour) > Click in system that can be deconstructed and reused	GROUND FLOOR > Treatment Area MEZZANINE > Waiting Area > Private Treatment Areas	> The look and feel of a timber floor adds warmth and a sense of comfort to the treatment areas. > The materiality of the timber floor also creates a non-visual connection with nature.	> Water resistant > Stain resistant > Durable & Resilient > Sound Proof > Low maintenance	LOCAL > WanabiWood (Boksburg, SA)	> EchoWood is Green Star certified and has a low environmental impact
	PORCELAIN TILE > Accessible Toilet MEZZANINE 300 x 600 3D Printed Natural Stone Full body R10	GROUND FLOOR > Accessible Toilet MEZZANINE > Ablution	> A porcelain tile with a natural stone finish is used to create bathroom facilities that have a visual connection with nature	> Non slip > Easy to clean > Non-porous	LOCAL > Union Tiles (Johannesburg, SA)	LEED Certified
WALL FINISH						
	EXPOSED BRICK WALL Exposed brick wall white washed with "Sure Coat Matt Acrylic" paint (Fiascon)	Existing wall structure	> The existing facebrick wall is white-washed to create a clean and refreshing surface that still adds a textural element to the space	> Durable > Robust > Sound absorbant	EXISTING	> Making use of the existing facebrick wall structure reduces material consumption through eliminating plastering
	DRYWALLS 15mm Gyproc SoundBloc Rhinoboard plastered and painted	MEZZANINE > Treatment area partition walls	> Sound absorbing drywall partitions offer lightweight partitioning systems that creates private enclosed areas	> Fire resistant > Sound insulation > Non combustible > Thermal insulation	LOCAL > Gyproc Saint Gobain (Centurion, SA)	> Gyproc Rhinoboard are Green Star certified and pose low environmental impact
	METRO WALL TILES 200 x 100 mm ceramic metro tile	MEZZANINE > Kitcheneette splash back	> The metro wall tiles create a fresh, clean and contemporary look and feel to the kitcheneette.	> Easy to clean > Durable (A-grade tile) > Stain resistant	LOCAL > Union Tiles (Johannesburg, SA)	> Contains recycled content and reduced carbon footprint
	PORCELAIN TILE > Accessible toilet and shower facilities MEZZANINE 300 x 600 3D Printed Natural Stone Full body R10	GROUND FLOOR > Accessible toilet and shower facilities MEZZANINE > Toilet and shower facilities	> A porcelain tile with a natural stone finish is used to create bathroom facilities that have a visual connection with nature	> Non slip > Easy to clean > Non-porous	LOCAL > Union Tiles (Johannesburg, SA)	LEED Certified
CEILING FINISH						
	SUSPENDED CEILING 9.5mm Gyproc Rhinoboard plastered and painted white	> Used throughout retail and treatment areas	> Rhinoboard is used for the ceiling - a lightweight and sustainable product easily manipulated to create the sloped suspended ceiling	> Fire resistant > Sound insulation > Non combustible > Thermal insulation	LOCAL > Gyproc Saint Gobain (Centurion, SA)	> Gyproc Rhinoboard are Green Star certified and pose low environmental impact
	TRANGULATED SKIN (Ceiling Installation) Calico 130gm African 100% Cotton with fire with retardant coating	> Used throughout retail and treatment areas	> The suspended ceiling installation is to provide a soft draped effect. A natural off-white material was chosen to bring a crisp and fresh feeling to the space.	> Durable > Versatile > Soft to touch > Fire retardant	LOCAL > Photogenic Sustainable Fabrics	> GOTS Certified Organic
FURNISHING						
	DISPLAY SYSTEM Organic lavender fiber composite with protein glue bond and waterproof sealant	> Used throughout retail and treatment areas	> The organic fiber composite creates a lightweight material that can be re-used as nutrient at the end of its lifecycle	> Lightweight > Bio-degradable > 100% Natural	Manufactured locally	> Bio-waste used as raw material > 100% biodegradable > Sequesters carbon
	COUNTER TOPS 20mm Caesarstone Quartz polished (Frosty Carina) > Skin bar counter top > Product testing counter top MEZZANINE > Waiting area bar counter top > Ablution counter tops	GROUND FLOOR > Skin bar counter top > Product testing counter top MEZZANINE > Waiting area bar counter top > Ablution counter tops	> Quartz countertops are used to create a clean and polished countertop surface	> Non-porous > Heat tolerant > Stain resistant	LOCAL > Caesarstone (Johannesburg, SA)	> Eco Specifier Certified > LEED Certified > Compliant with numerous Green Star Criteria
	COUNTER TOP 20mm Caesarstone Quartz polished (White Shimmer)	MEZZANINE > Kitcheneette	> Quartz countertops are used to create a clean and polished countertop surface	> Non-porous > Heat tolerant > Stain resistant	LOCAL > Caesarstone (Johannesburg, SA)	> Eco Specifier Certified > LEED Certified > Compliant with numerous Green Star Criteria
	ARMCHAIRS 660 x 890 x 760mm Caprice chair white with teak	MEZZANINE > Waiting area	> The caprice chairs provide comfortable and relaxing seating for guests who are in the waiting area	N/A	LOCAL > @Home (Johannesburg, SA)	N/A
	BAR STOOLS 280 x 280 x 650 > Combo oregon limber bar stools	MEZZANINE > Waiting area bar counter seating	> The limber bar stools have a triangulated leg structure which resonates with the triangulated display system	N/A	LOCAL > Eco Furniture Design (Woodstock, SA)	> Furniture contains recycled content
SANITARY FITTINGS						
	HIGH EFFICIENCY TOILET 4.8 L Flush Concealed cistern toilet	GROUND FLOOR > Accessible bathroom MEZZANINE > Communal Ablution	> A high efficiency/ low-flow toilet is specified to reduce water consumption in the abluition facilities	N/A	LOCAL Bathroom Bazaar (Pretoria, SA)	> Reduced water consumption
	TAPS > Tap fitting to resemble laboratory taps > Low flow aerator fitting used to reduce water flow	GROUND FLOOR > Product testing area MEZZANINE > Hand wash area	> A high efficiency/ low-flow aerator is specified to reduce water consumption in the abluition facilities	N/A	LOCAL Bathroom Bazaar (Pretoria, SA)	> Reduced Water Consumption
	SHOWER HEAD EcoSmart Raindance Showerhead 2L/min	GROUND FLOOR > Accessible bathroom MEZZANINE > Communal shower area	> A high efficiency/ low-flow shower head is specified to reduce water consumption in the abluition facilities	N/A	LOCAL Bathroom Bazaar (Pretoria, SA)	Reduced Water Consumption

Figure 7.8. Collage of material selection (Author, 2016).

7.3 SERVICES

7.3.1 ACOUSTICS

SECTION A - ACOUSTIC APPLICATION

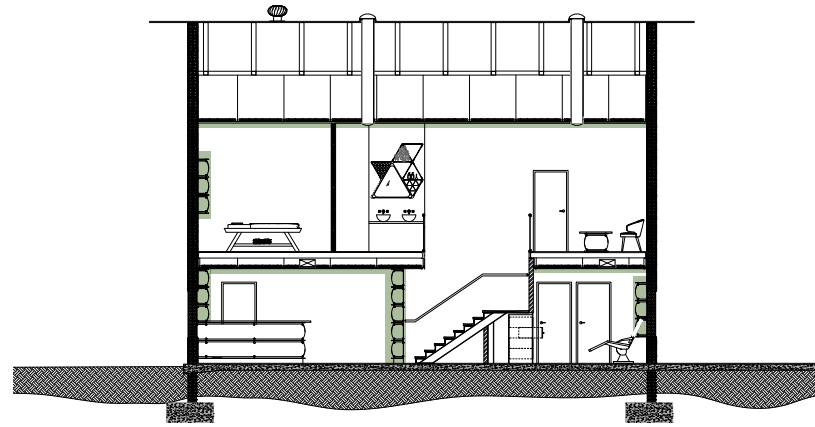

G/F ACOUSTIC APPLICATION

MEZZANINE ACOUSTIC APPLICATION

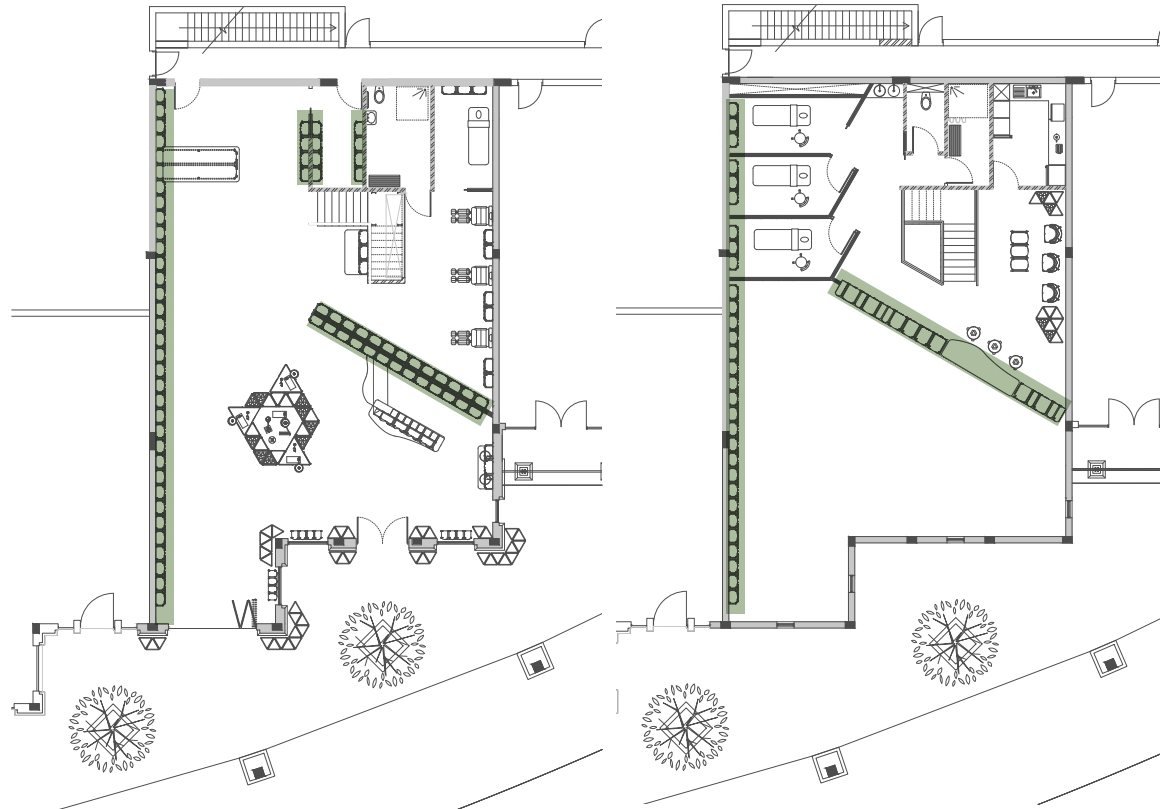

Figure 7.9. Diagram showing acoustic considerations (Author, 2016).

7.3.2 DAYLIGHT STRATEGY

In order to maximise the benefits of daylight in the interior space, the design strategy has made provision for SolaTubes which will reduce the artificial lighting required.

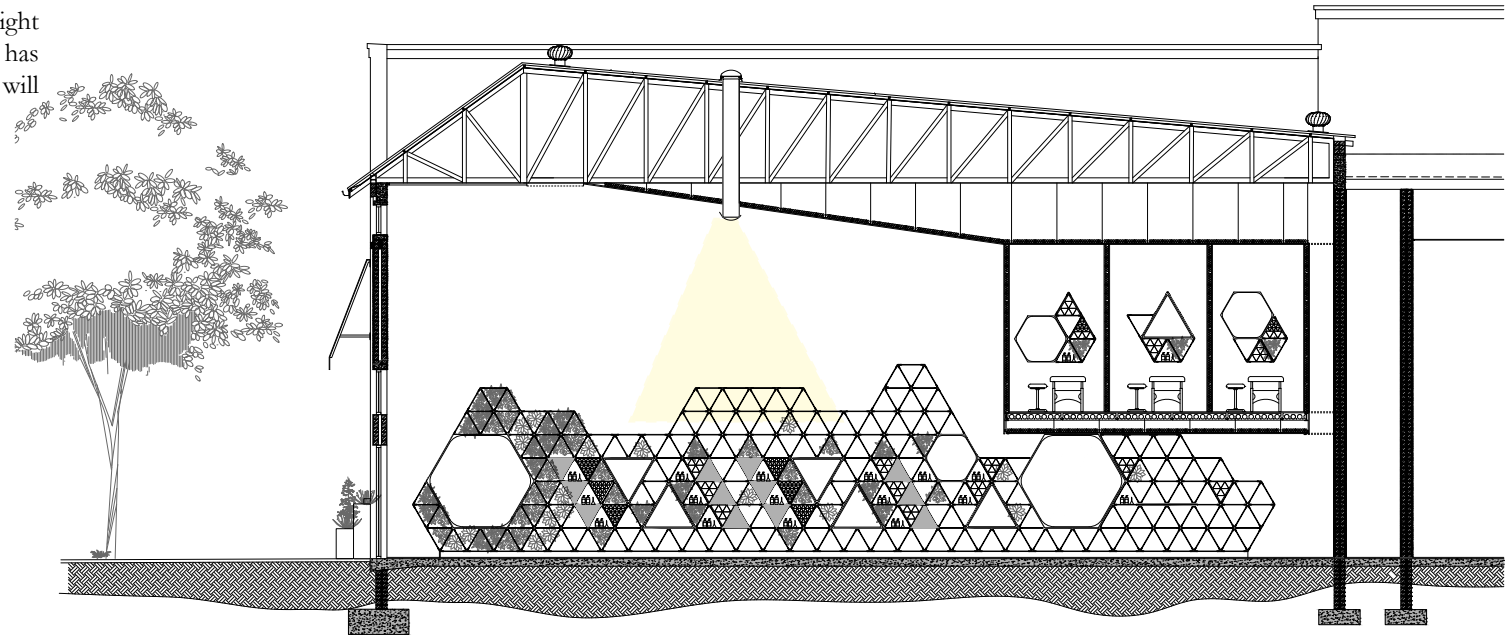

Figure 7.10. Diagram showing passive lighting strategy (Author, 2016).

Solatube 330DS Specifications

(530mm diameter) Daylighting System with 600 x 600mm transition box and diffuser

Roof Mounted Tubular Daylighting System with UV and Impact resistant Inner Dome, Spectralight Infinity 99.7% Spectral reflectivity solid tubing with ceiling level Optiview Dual Glazed diffuser assembly, transferring sunlight to interior spaces.

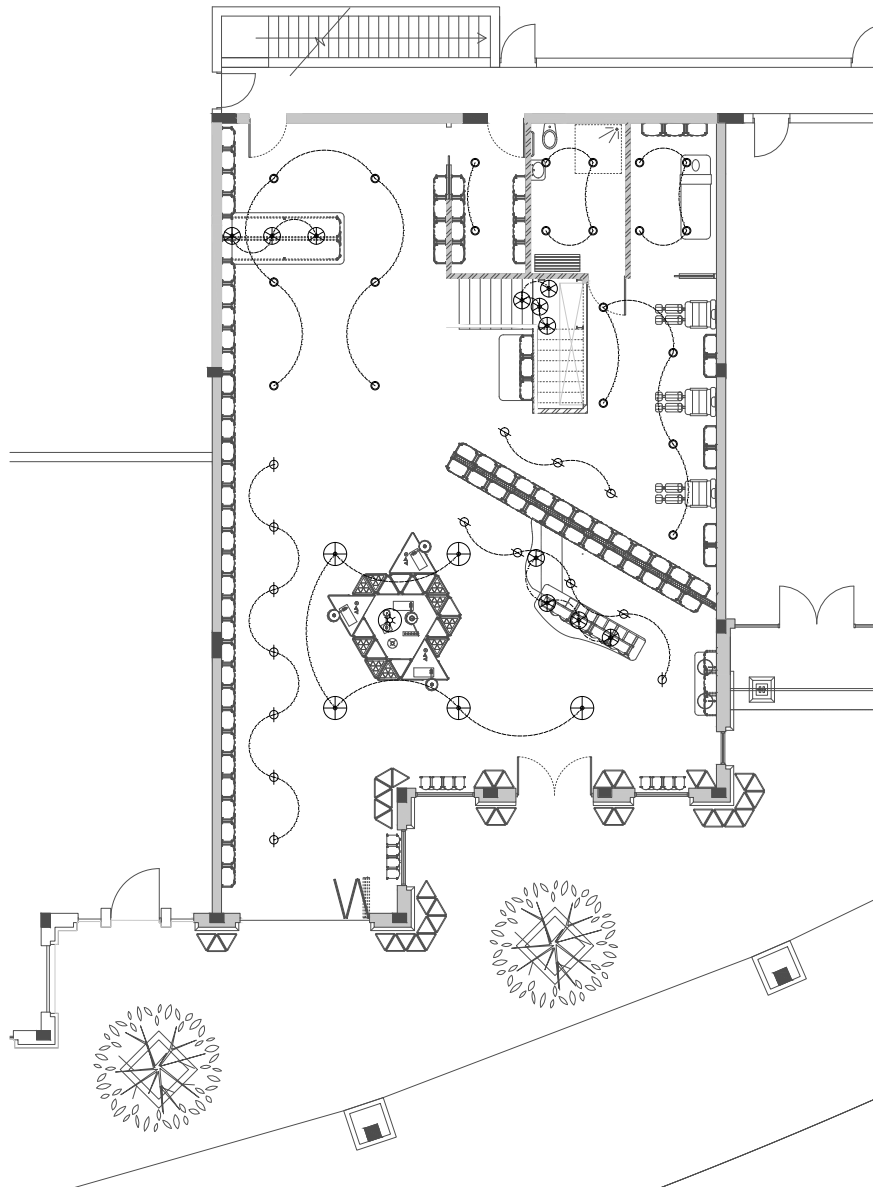

Figure 7.11. Solatube image and specifications (Solatube, 2016).

ARTIFICIAL LIGHTING SPECIFICATIONS

SYMBOL							
APPLICATION	Accent Lighting: > Window Displays	Accent Lighting: > Vertical Displays > Floor Display	General lighting (GF)	Accent Lighting: > Above Skin Bar > Above POS/Reception > Above Stairs	Undercounter lighting	General lighting: > Under mezzanine > Ablution > Kitchenette	Soft General Lighting: > Treatment Areas > Waiting Area
LUMINAIRE DESCRIPTION	LED Spotlights 50mm diameter	Tension wire spotlights	Large industrial pendant	Bentwood pendant lights	LED Strip lights	Adjustable downlights	Wall mounted light
LUMINAIRE							
LAMP DESCRIPTION	100mm Glimball downlight 45 adjustable tilt	100mm Glimball downlight 45 adjustable tilt	125mm LED Smoked glass globe with LED filament technology	125mm LED Smoked glass globe with LED filament technology	5000mm LED Strip Light	100mm Glimball downlight 45 adjustable tilt	LED Filament E14 Candles Dimmable
LAMP							
COLOUR RENDERING (K)	5000K	5000K	5000K	5000K	3500K	2700K	2700K
QUANTITY	8	20	5	10	6	29	8
lm/LAMP	65lm	65lm	150lm	150lm	85lm	65lm	70lm
WATTAGE	5W	5W	2W	2W	24W	2W	4W

G/F ARTIFICIAL LIGHTING



MEZZANINE ARTIFICIAL LIGHTING

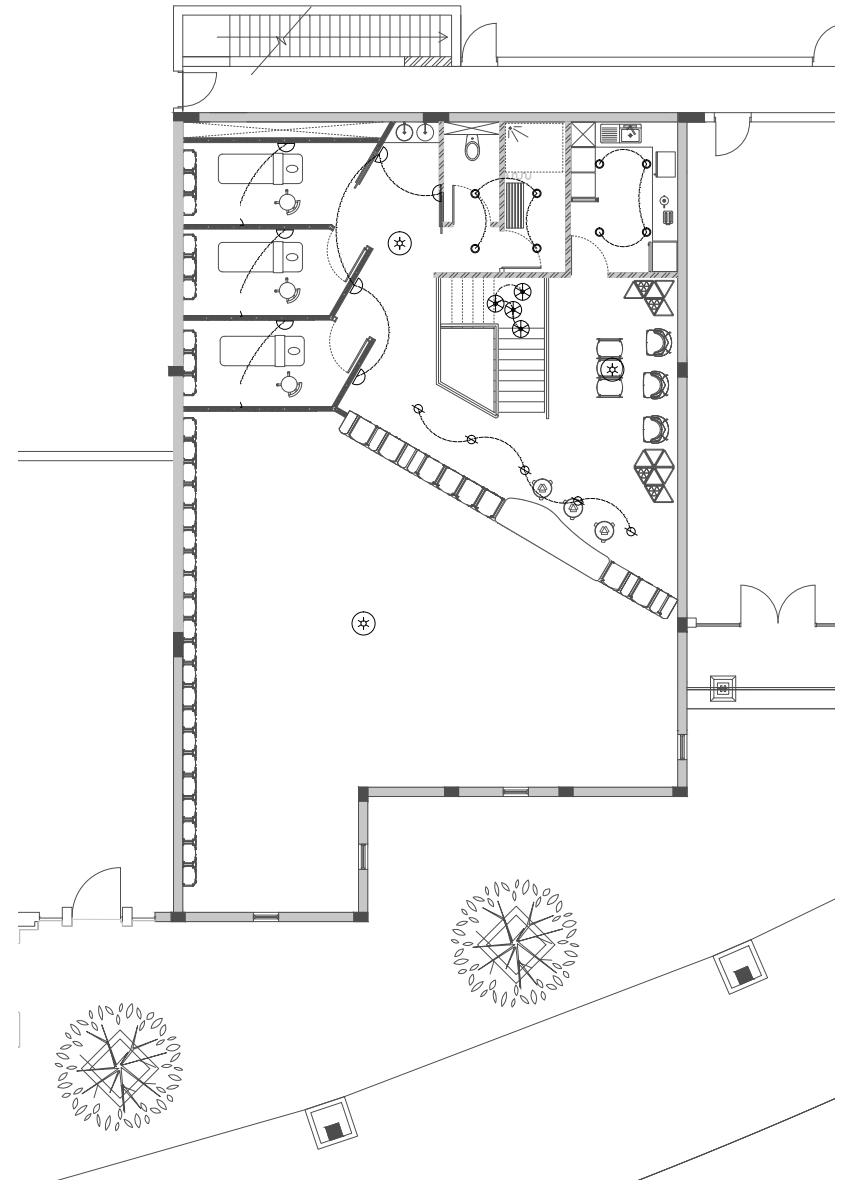

Figure 7.12. Artificial lighting plan
(Author, 2016).

7.3.3 PASSIVE VENTILATION STRATEGY

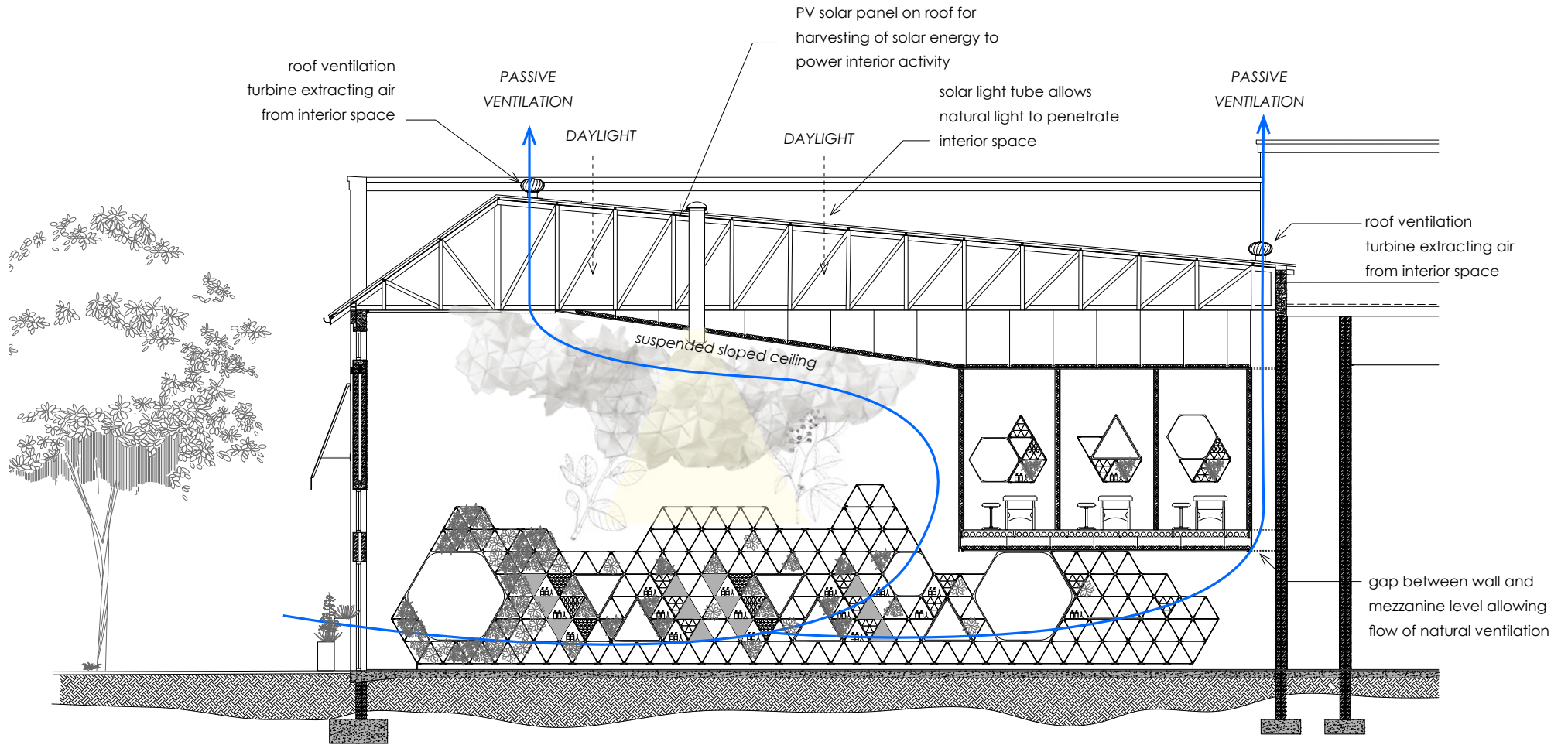
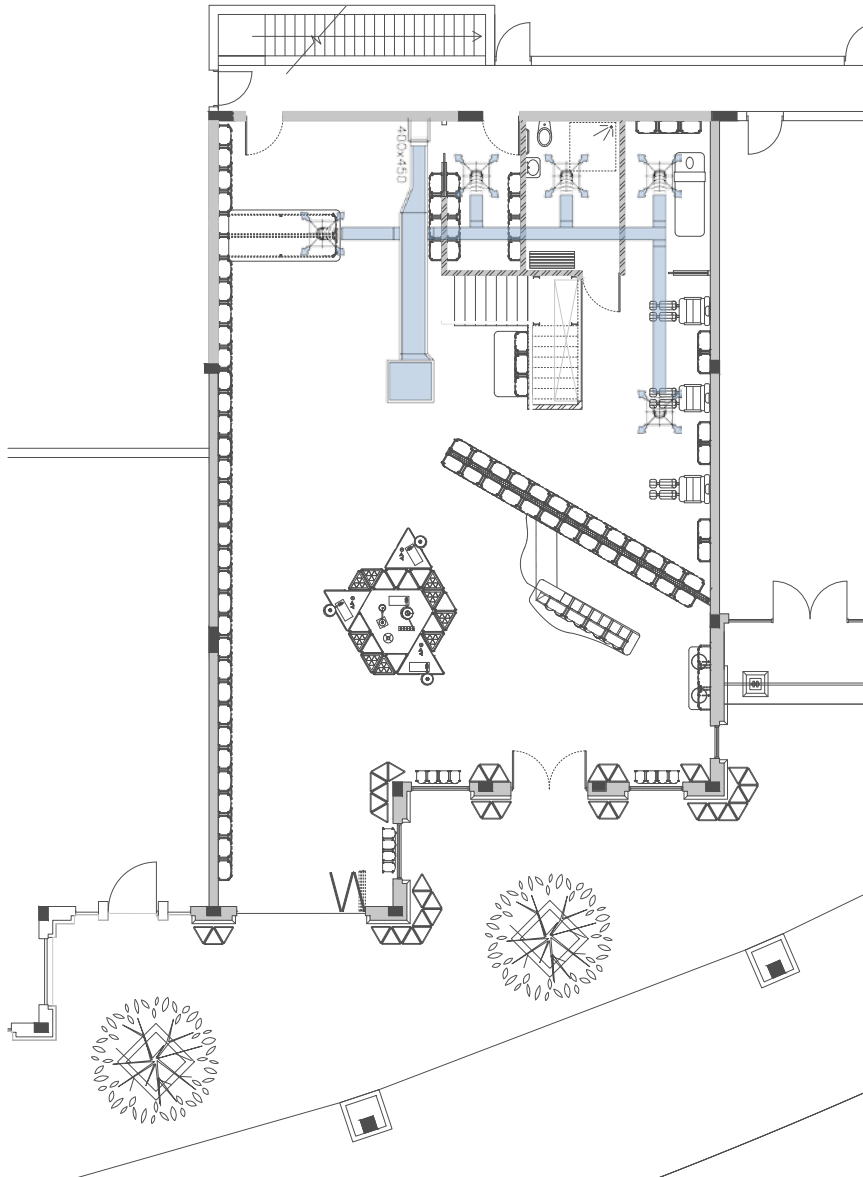

Figure 7.13. Diagram showing passive systems design (Author, 2016).

G/F ARTIFICIAL VENTILATION



MEZZANINE ARTIFICIAL VENTILATION

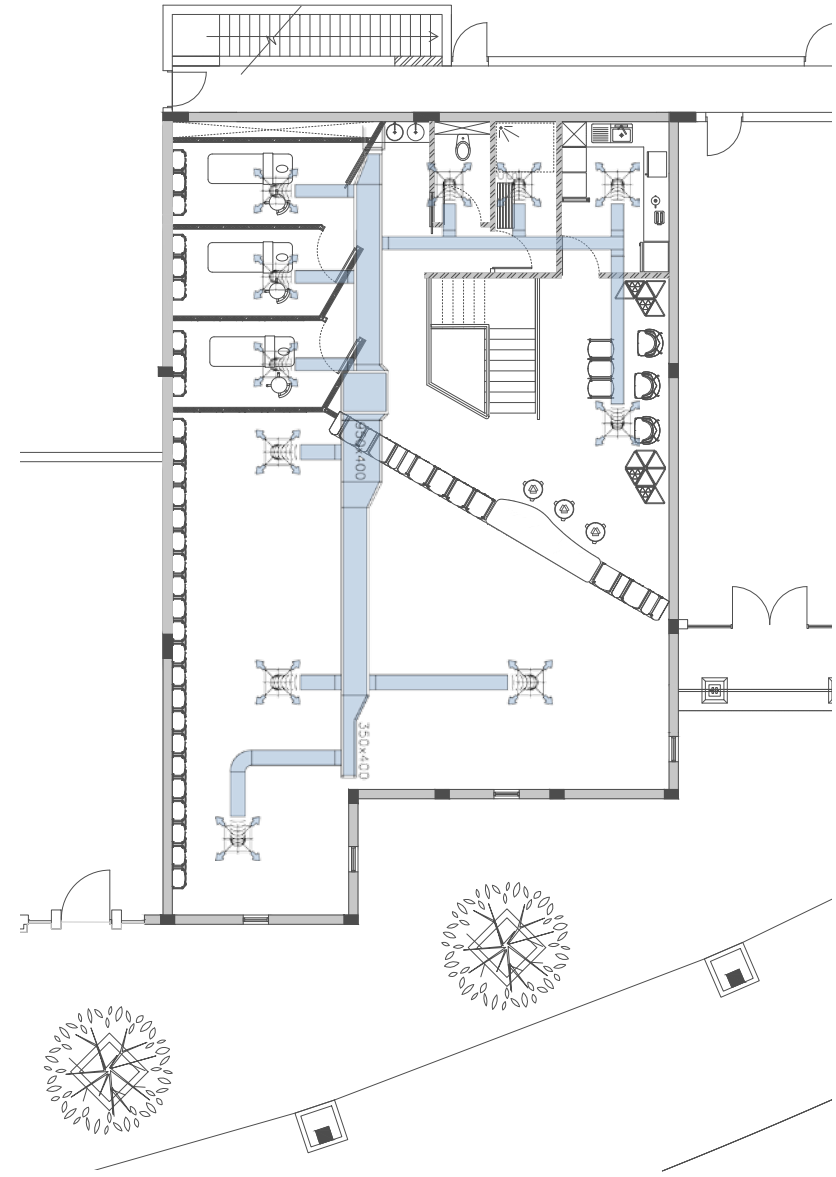

Figure 7.14. Artificial lighting plan
(Author, 2016).

7.4 DETAIL INVESTIGATION OF DISPLAY DESIGN

CONFIGURATION OF PACKAGING
WITHIN TRIANGULATED DISPLAY

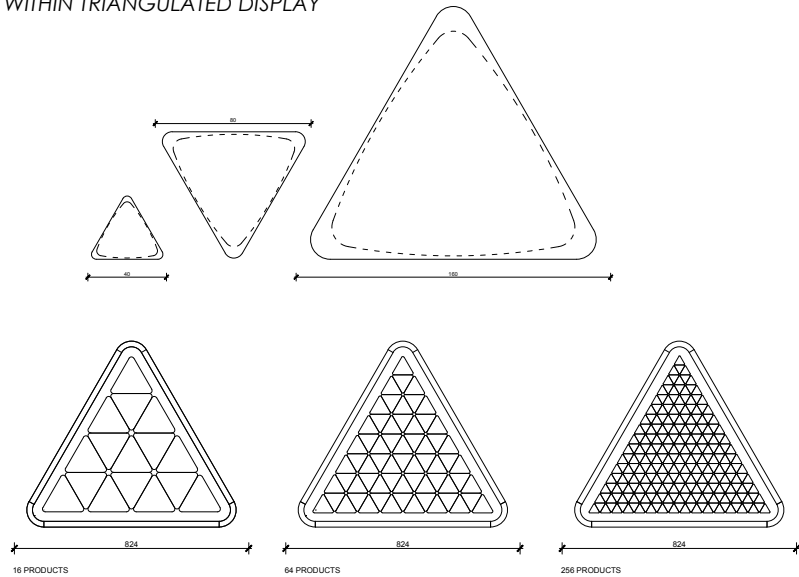

Figure 7.15. Packaging within display system (Author, 2016).

AXONOMETRIC:
CONFIGURATION OF TRIANGULATED DISPLAY

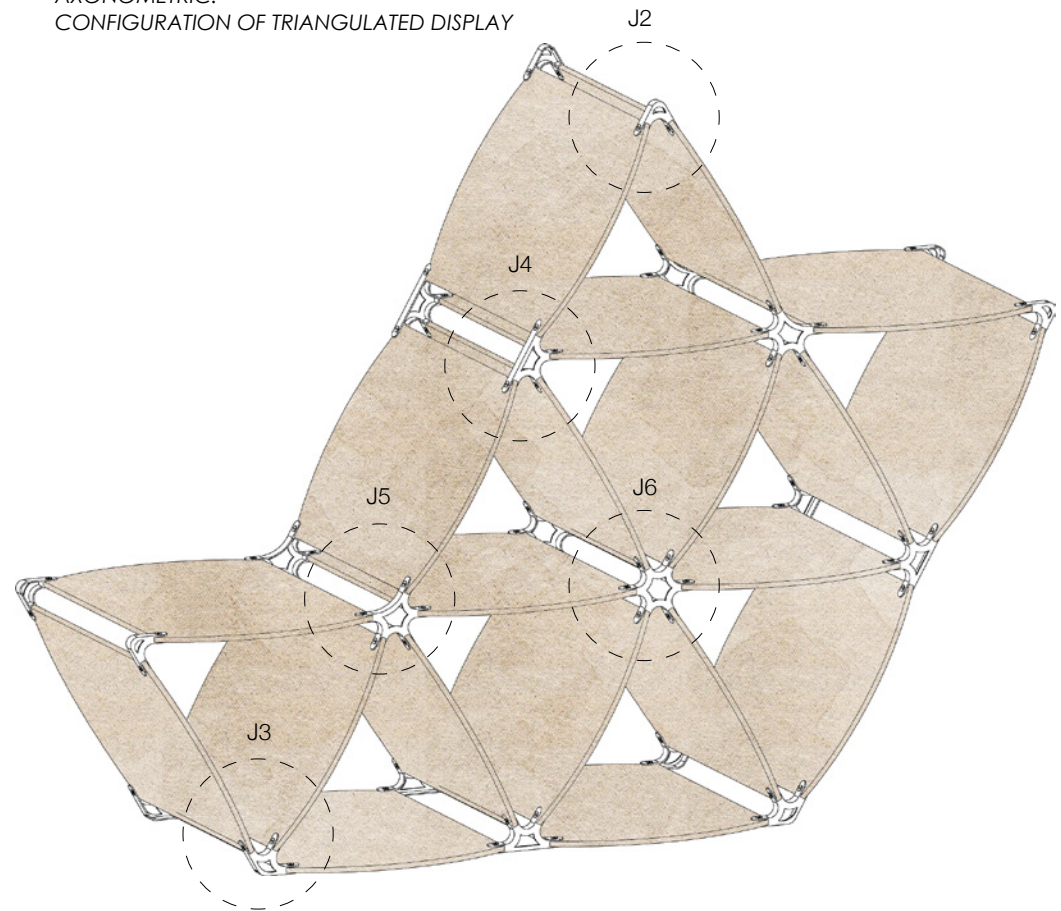

Figure 7.17. Axonometric of Vertical Display (Author, 2016).

Figure 7.16. (Left) Vertical Display Grid (Author, 2016).

CONNECTION JOINTS

DISPLAY PANELS SHAPE

ITERATION

AXONOMETRIC

FRONT ELEVATION

ITERATION

1

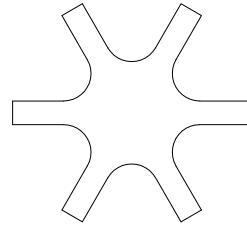
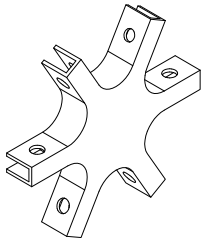

1

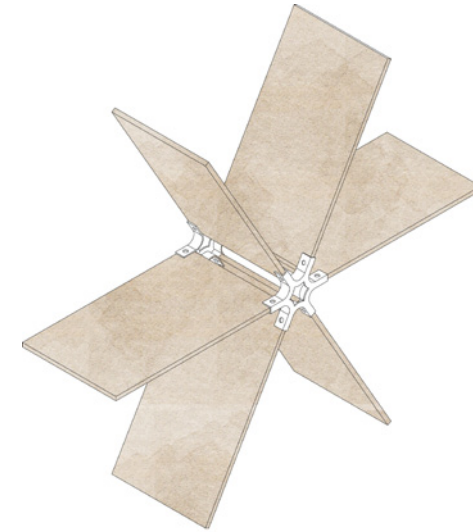

J6: 6-Point Display Joint Connection
Not to Scale

DETAIL 1_FRONT ELEVATION
J6: 6-Point Display Joint Connection
Not to Scale

2

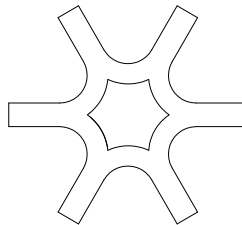
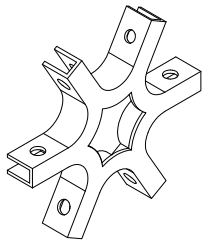

2

DETAIL 1_FRONT ELEVATION
J6: 6-Point Display Joint Connection
Not to Scale

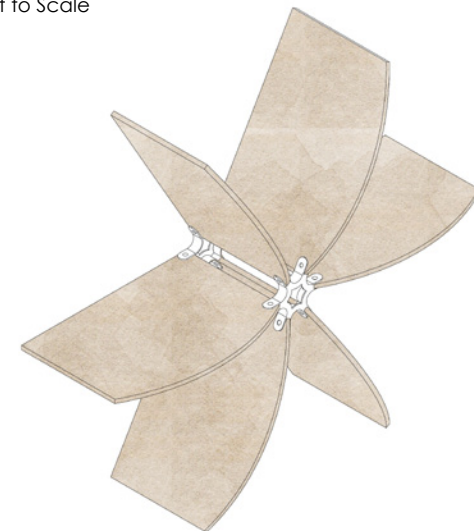

DETAIL 1_FRONT ELEVATION
J6: 6-Point Display Joint Connection
Not to Scale

3

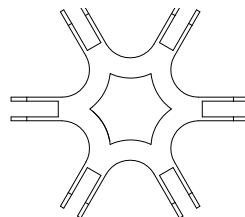
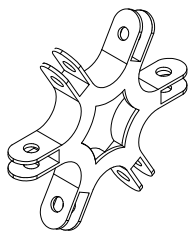

DETAIL 1_FRONT ELEVATION
J6: 6-Point Display Joint Connection
Not to Scale

Figure 7.18. Iteration of connection joints and display panels (Author, 2016).

3D PRINTED JOINT CONNECTIONS_AXONOMETRIC

Not to Scale

J6

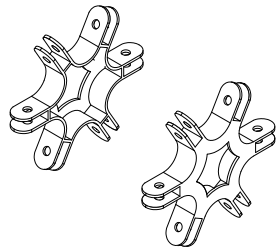

3D PRINTED PET RECYCLED
PLASTIC 6-POINT JOINT

J5

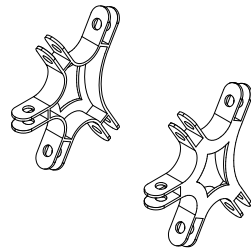

3D PRINTED PET RECYCLED
PLASTIC 5-POINT JOINT

J4

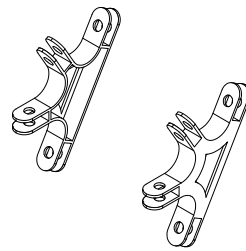

3D PRINTED PET RECYCLED
PLASTIC 4-POINT JOINT

J3

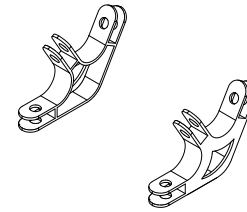

3D PRINTED PET RECYCLED
PLASTIC 3-POINT JOINT

J2

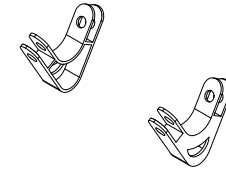

3D PRINTED PET RECYCLED
PLASTIC 2-POINT JOINT

3D PRINTED JOINT CONNECTIONS_FRONT ELEVATION

Not to Scale

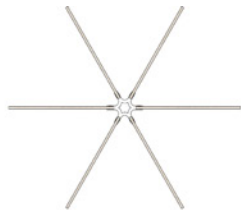

3D PRINTED JOINT CONNECTIONS_AXONOMETRIC

Not to Scale



Figure 7.19. Detailing of connection joints (Author, 2016).

KIT OF PARTS

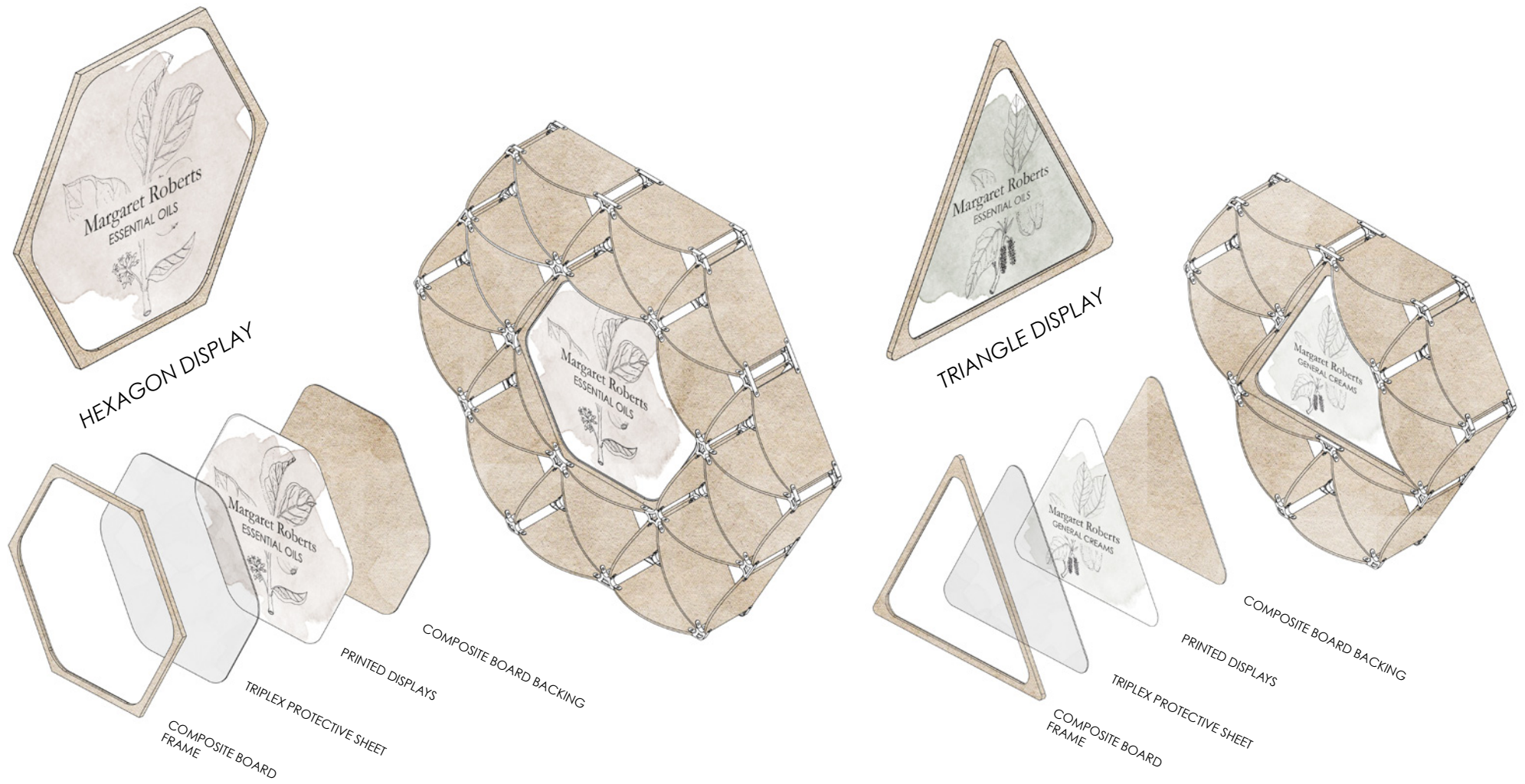
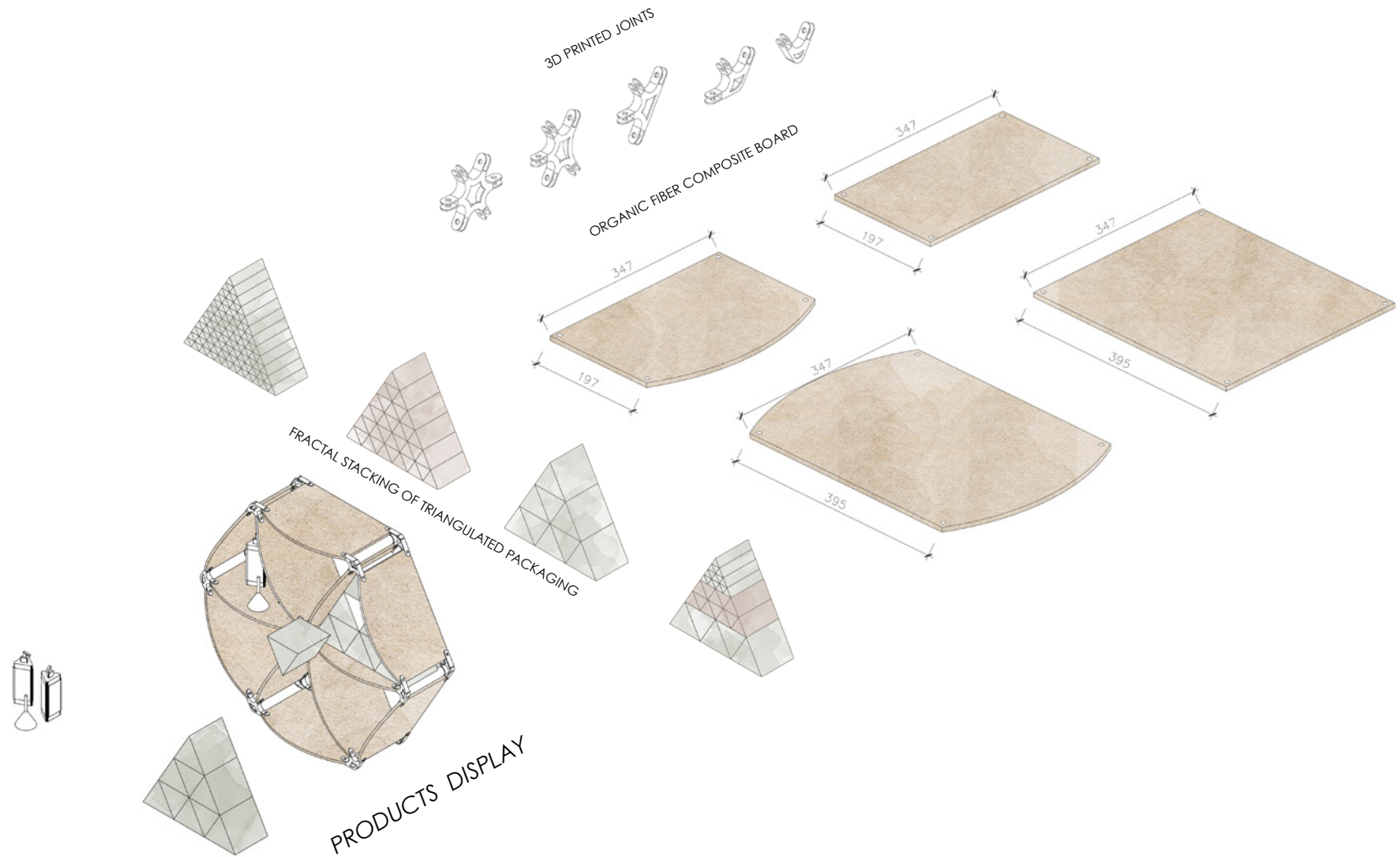

Figure 7.20. Detailing of 'Kit of Parts'
(Author, 2016)



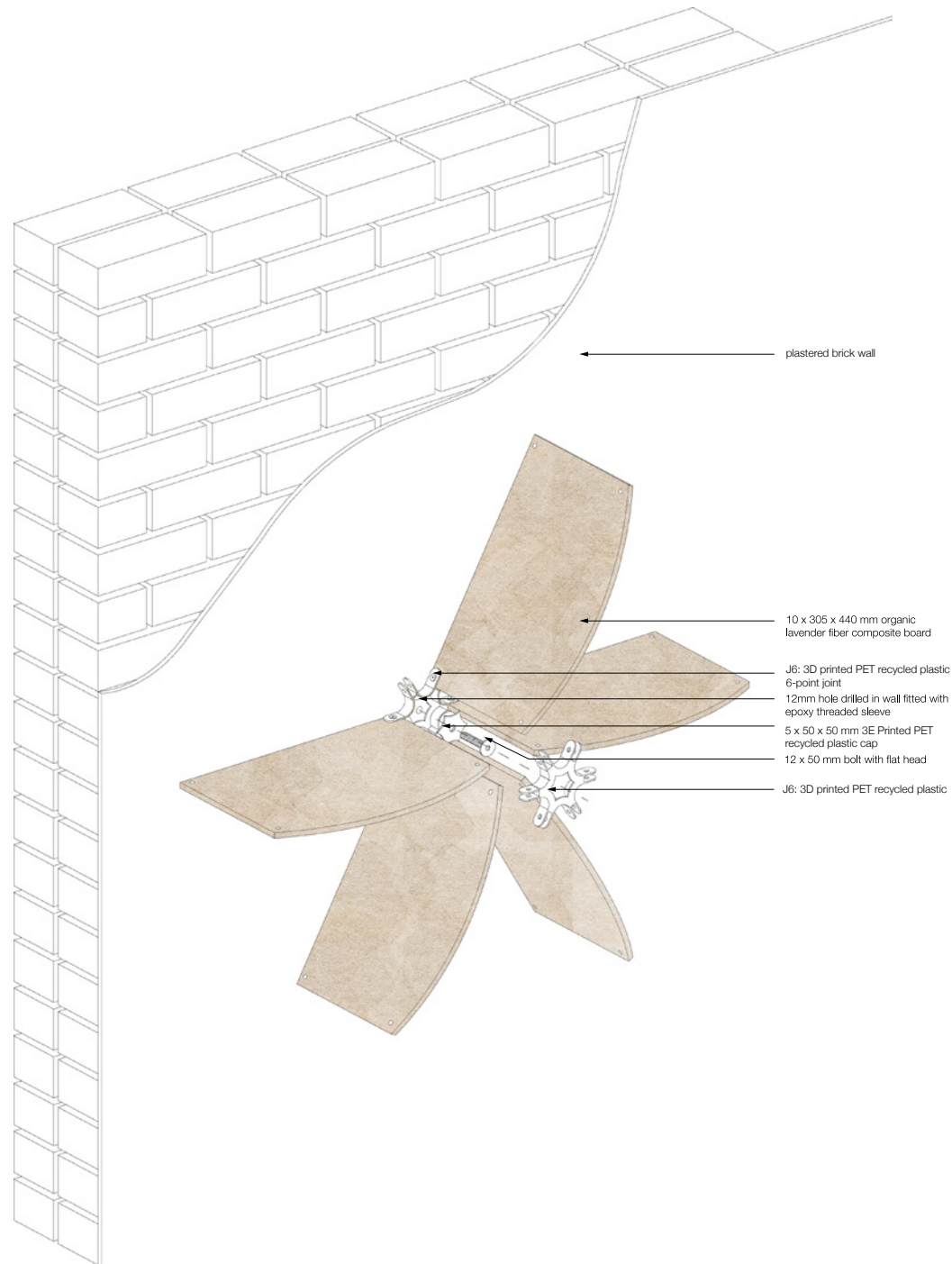

Figure 7.21. Axonometric of vertical display to wall connection (Author, 2016).

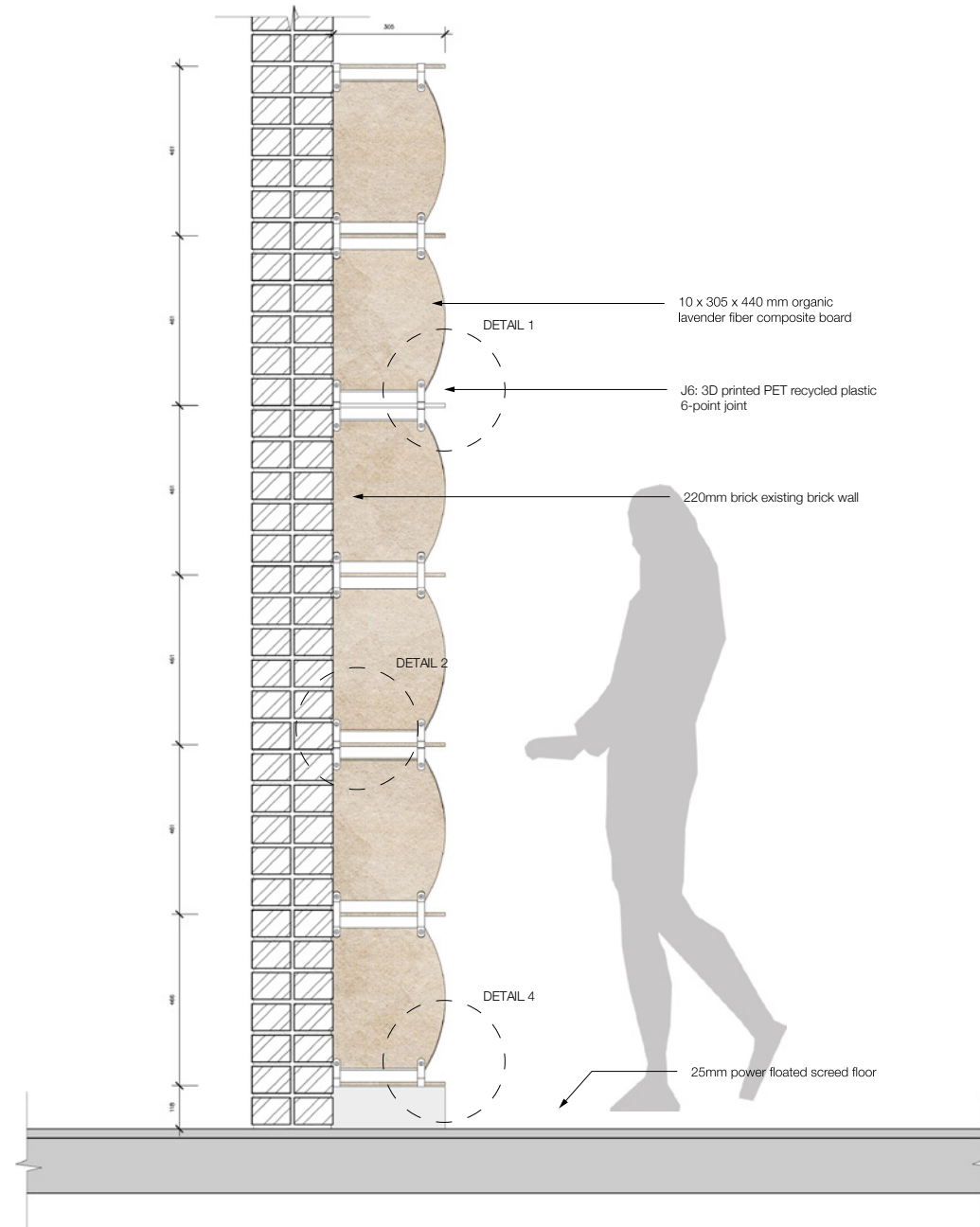
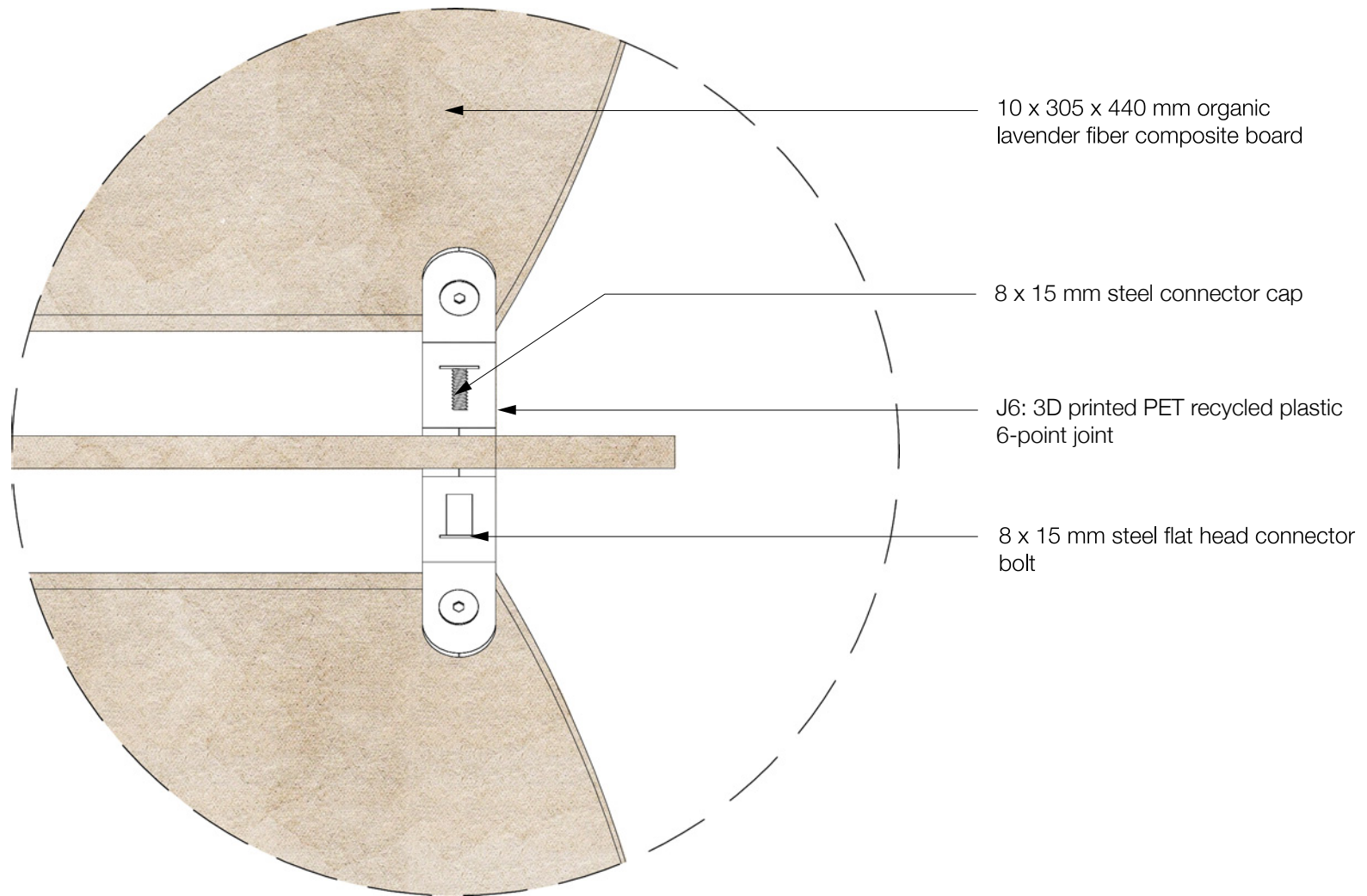
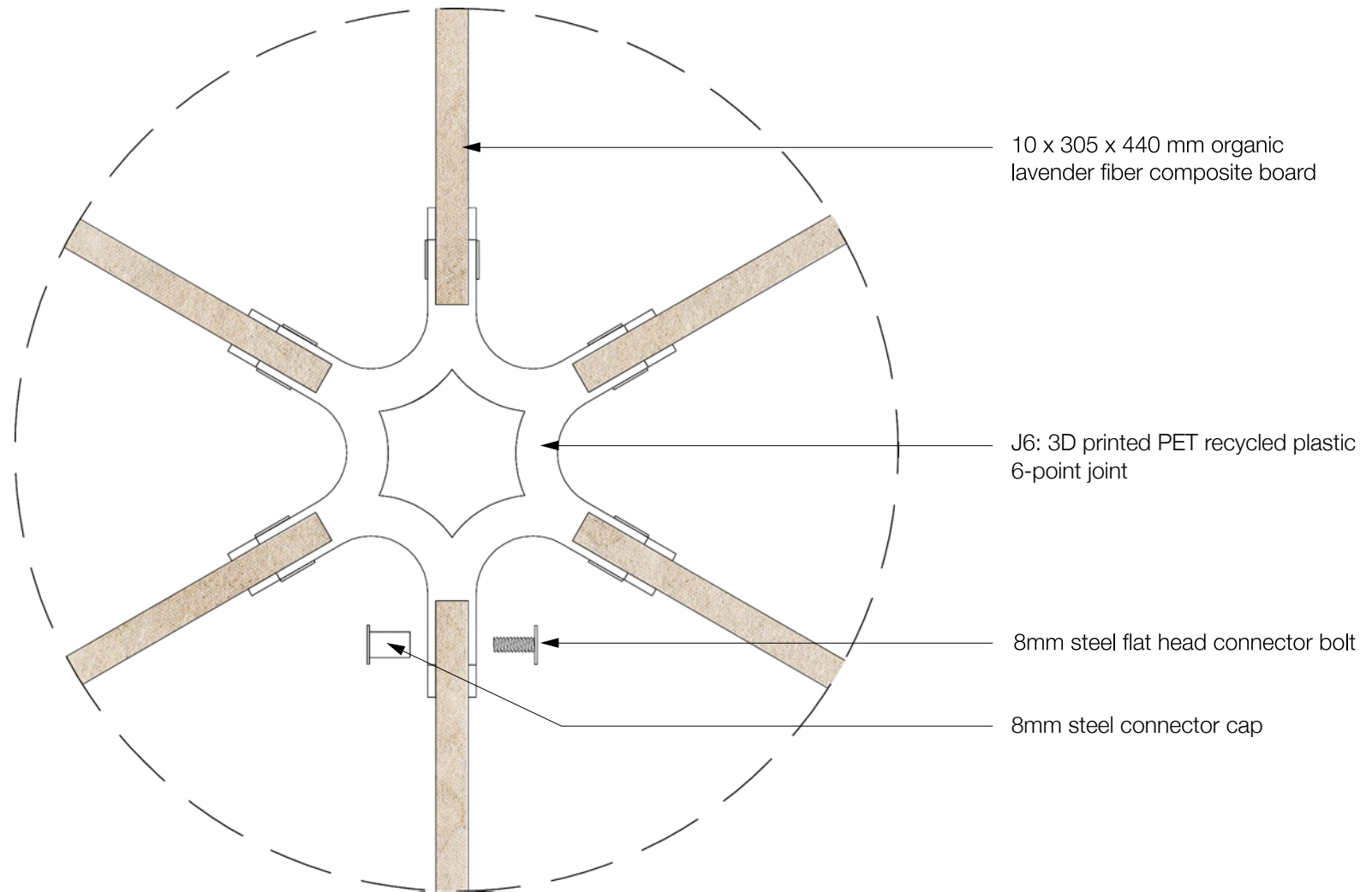

Figure 7.22. Section through vertical display
(Author, 2016).



DETAIL 1
VERTICAL DISPLAY CONNECTION DETAIL
not to scale

Figure 7.23. Detail 1: Vertical display
Connection detail (Author, 2016)



DETAIL 1
VERTICAL DISPLAY CONNECTION DETAIL FRONT ELEVATION
not to scale

Figure 7.24. Detail 1: Front Elevation
(Author, 2016).

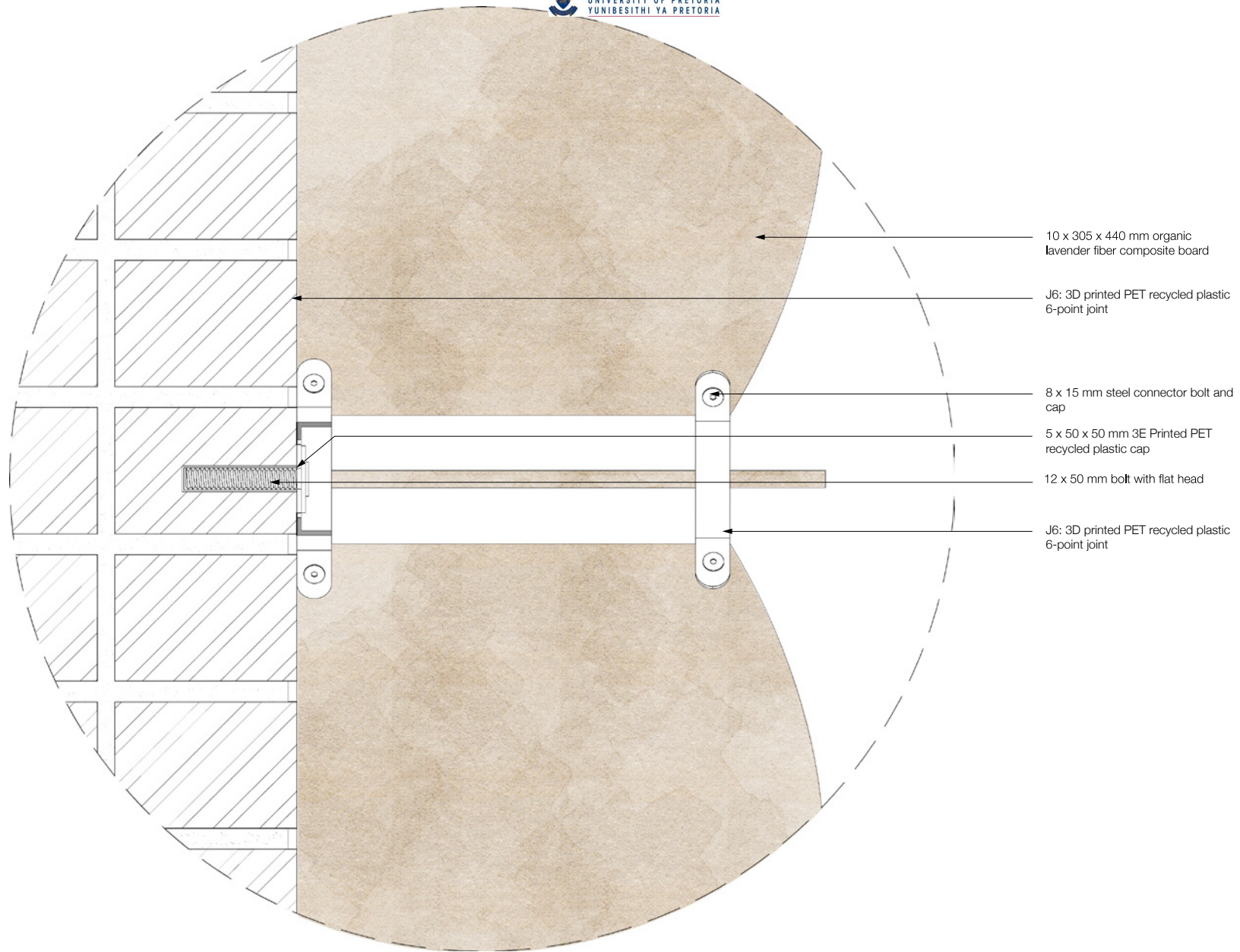

DETAIL 2
VERTICAL DISPLAY WALL CONNECTION
not to scale

Figure 7.25. Detail 2: Vertical display wall connection (Author, 2016)

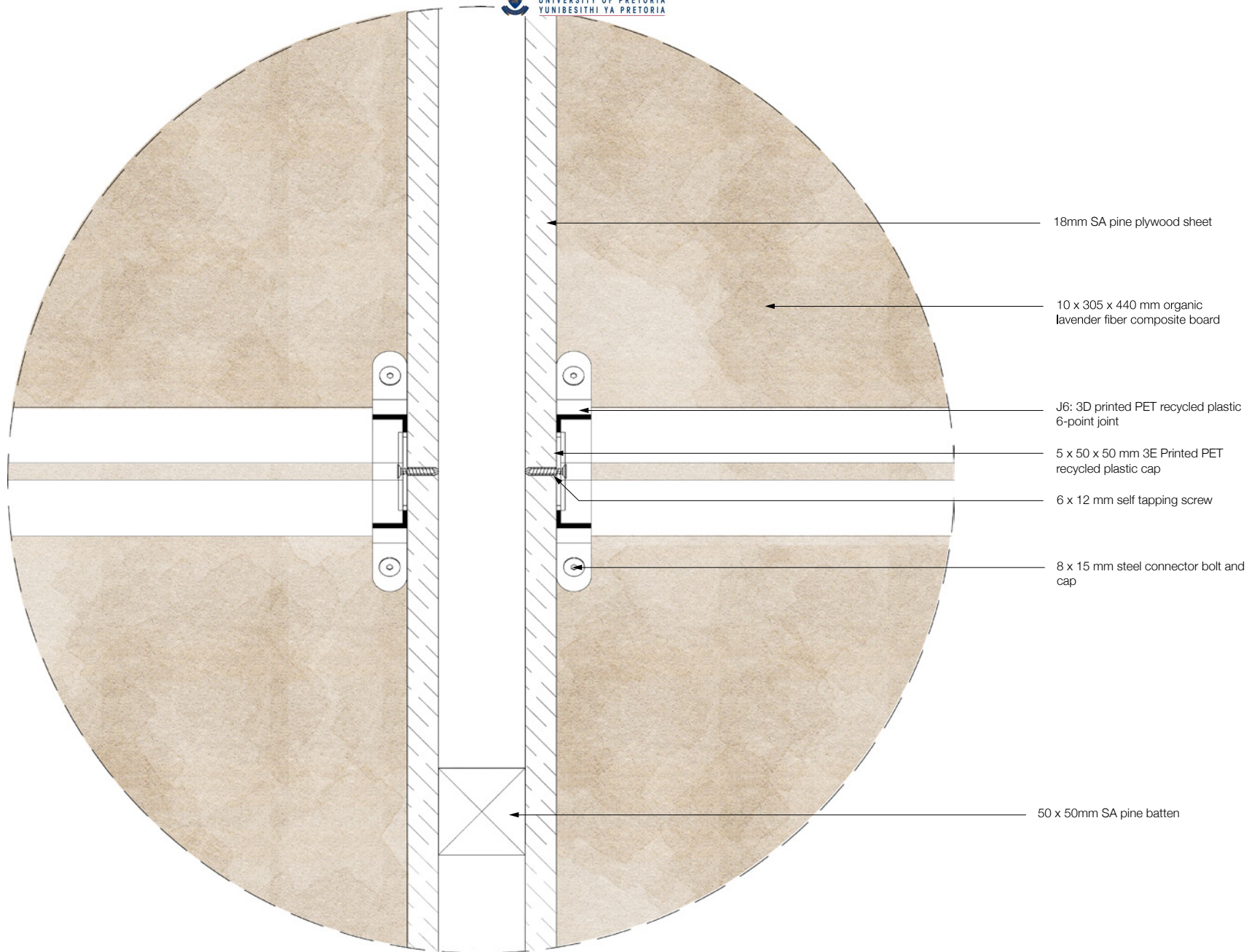

DETAIL 3
DRY WALL CONNECTION
not to scale

Figure 7.26. Detail 3: Dry wall connection (Author, 2016).

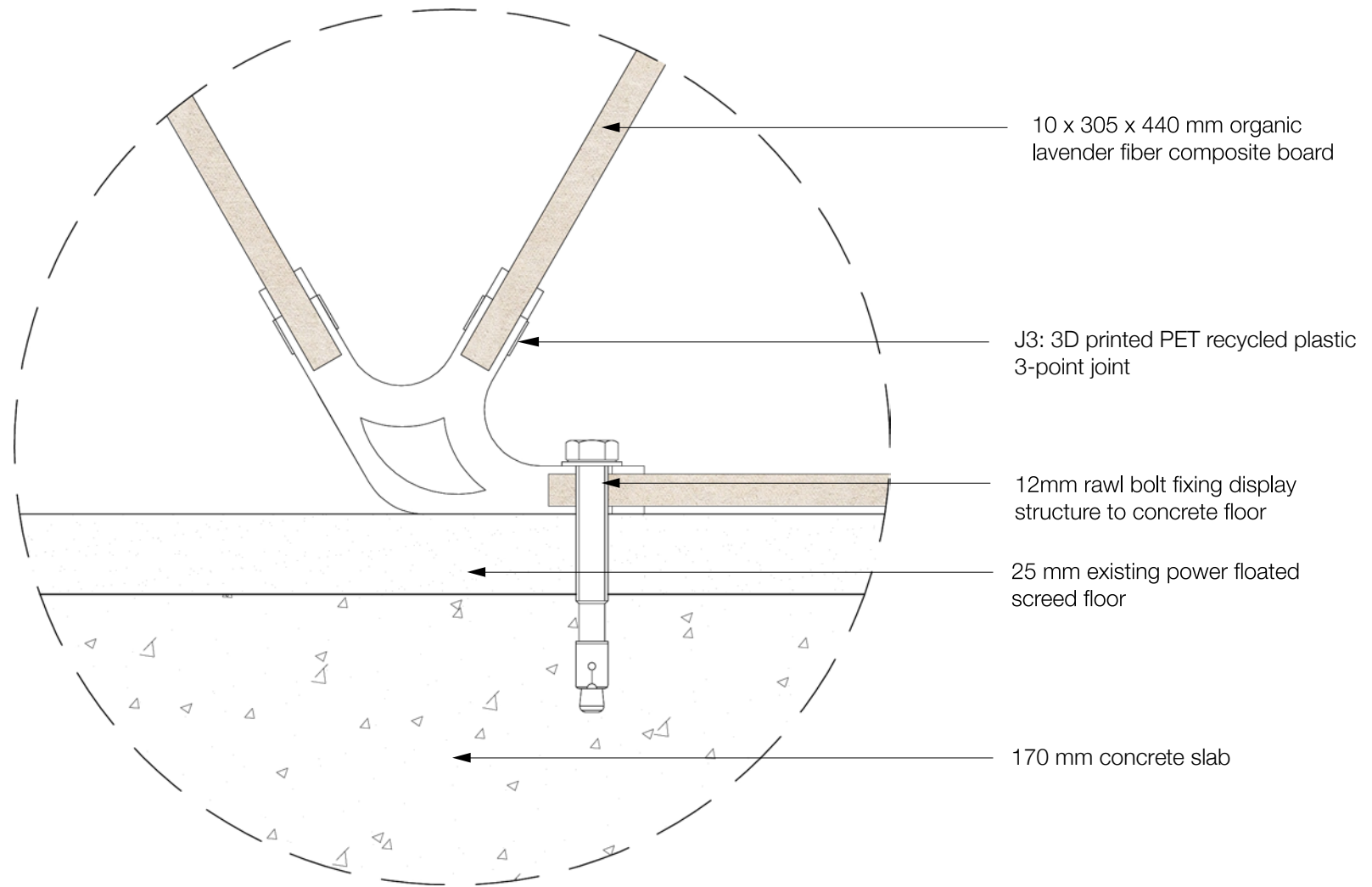

DETAIL 4
FLOOR CONNECTION
not to scale

Figure 7.27. Section through vertical display (Author, 2016).

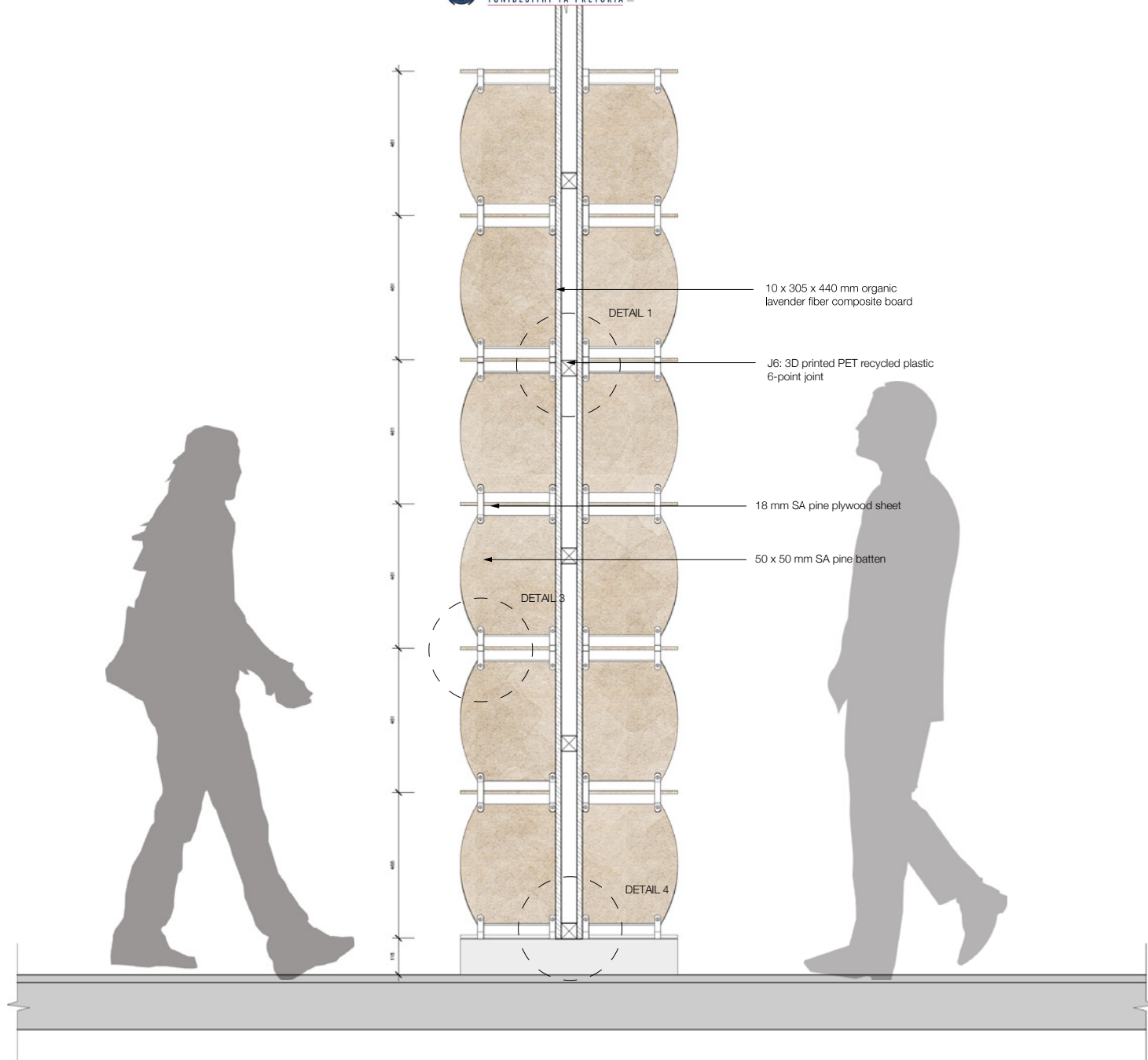

Figure 7.28. Section through vertical display behind Skin Bar (Author, 2016)

VERTICAL DISPLAY - DRY WALL CONNECTION
not to scale

7.5 ENVIRONMENTAL POTENTIAL ASSESSMENTS

7.5.1 GBCSA GREEN STAR RATING

The GBCSA Green Star Interior rating tool was used to assess the environmental impact of the proposed design solution. The design of Margaret Roberts skincare servicescape achieved a 6 Star World Leadership rating, which was achieved through the implementation of Biomimicry and Biophilia design principles.

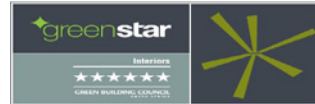

Score Sheet

Green Star SA - Interiors v1

Credit	Credit Name	Aim of Credit	Points Available	Points Targeted
Management Category				
Int-Man-1	Green Star SA Accredited Professional	To encourage and recognise the engagement of professionals who can assist the project team with the integration of Green Star SA aims and processes throughout all stages of a fitout's design and construction phases.	1	1
Int-Man-2	Commissioning & Tuning	To recognise effective commissioning and tuning processes during a project's design and construction phase that ensure all services and installations can operate to their optimal design potential.	2	2
Int-Man-3	Occupant Users' Guide	To encourage and recognise the provision of information to fitout owners and users that helps them understand a project's systems, environmental attributes, and maintenance requirements.	1	1
Int-Man-4	Environmental Management	To encourage and recognise the adoption of a formal environmental management system in line with established guidelines during construction.	1.5	1.5
Int-Man-5	Construction Waste Management	To recognise and encourage management practices that minimise the amount of demolition and construction waste going to disposal.	2	2
Int-Man-6	Work space efficiency	To recognise the design of workspaces that provide spatial efficiency and improve productivity and occupant performance.	2	2
Int-Man-7	Green Lease	To encourage and encourage collaboration between the building owner and tenants in order to manage and operate the building along environmentally sustainable principles whilst realising mutual benefit.	2	2
Int-Man-8	Learning Resources	To encourage and recognise sustainability initiatives implemented in the development as learning resources for building users and visitors.	1	1
Management credits			12,5	12,5
Indoor Environmental Quality Category				
Int-IEQ-1	Quality of Internal Air	To encourage and recognise projects that provide high quality air to occupants.	4	3
Int-IEQ-2	Thermal Comfort	To encourage and recognise fitouts that achieve a high level of thermal comfort.	2	2
Int-IEQ-3	Lighting Comfort	To encourage, recognise and reward well-lit spaces that provide appropriate levels of lighting comfort to occupants.	3	2
Int-IEQ-4	Visual Comfort	To recognise the delivery of well daylight spaces that provide high levels of visual comfort and views to fit-out occupants.	3	3
Int-IEQ-5	Acoustic Quality	To encourage and recognise buildings that are designed to provide appropriate acoustic qualities to enable the functionality of the space.	2	2
Int-IEQ-6	Reduced Exposure to Air Pollutants	To recognise projects that safeguard occupant health through the reduction in internal air pollutant levels.	5	4
Int-IEQ-7	Mould Prevention	To encourage and recognise the design of services that eliminates the risk of mould growth and its associated detrimental impact on occupant health.	0,5	0,5
Int-IEQ-8	Ergonomics	To recognise the choice of equipment and design of spaces that promotes wellbeing, efficiency and effectiveness.	2	2
Int-IEQ-9	Indoor Plants	To encourage and recognise the installation of indoor plants that improve indoor environment quality and also provides occupants with a connection to nature.	1,5	1,5
Indoor Environmental Quality credits			23	20
Energy Category				
Int-Ene-1	Greenhouse Gas Emissions	To encourage and recognise projects that minimise the greenhouse gas emissions associated with tenant fit outs.	12	8
Int-Ene-2	Electrical Sub-metering	To encourage and recognise projects that minimise the greenhouse gas emissions associated with tenant fit outs.	2	2
Energy credits			14	10

Transport Category				
Int-Tra-1	Commuting Mass Transport	To encourage and recognise developments that select a site near public transport and facilitate the use of mass transport.	1	0
Int-Tra-2	Local connectivity	To encourage and recognise projects that are located within walking distance of high quality amenities such as shops and parks, thus reducing private vehicle use and the associated negative environmental impacts.	1	1
Int-Tra-3	Alternative Transport	To encourage and recognise projects that promote and facilitate the use of alternative modes of transport over the use of private cars.	2	0
Transport credits			4	1
Water Category				
Int-Wat-1	Potable Water	To recognise projects that minimise potable water consumption.	6	3
Int-Wat-2	Water Sub-metering	To encourage and recognise the installation of sub-metering to facilitate on-going management of water consumption.	2	2
Water credits			8	5
Materials Category				
Int-Mat-1	Operational Waste Management	To encourage and recognise developments which include space and an operational waste management plan that facilitates the recovery of resources used within the developments to reduce waste going to disposal.	2	2
Int-Mat-2	Furniture	To recognise the selection of fit-out furniture that has a reduced environmental impact when compared to available alternatives.	8	5
Int-Mat-3	Assemblies	To recognise the selection of fit-out assemblies that have a reduced environmental impact when compared to available alternatives.	8	6
Int-Mat-4	Flooring	To recognise the selection of flooring that has a reduced environmental impact when compared to available alternatives.	6	4
Int-Mat-5	Wall coverings	To recognise the selection of wall coverings that have a reduced environmental impact when compared to available alternatives.	3	3
Int-Mat-6	Local Sourcing	To encourage and recognise the environmental advantages gained, in the form of reduced transportation emissions, by using materials and products that are sourced within close proximity to the site.	2	1
Int-Mat-7	Sundries Materials Sourcing	To recognise the selection of fitout finishes that have a reduced environmental impact when compared to available alternatives through responsible manufacturing, product stewardship and resource efficient design.	1	1
Materials credits			30	22
Land Use and Ecology Category				
Int-Eco-1	Site selection	To recognise and reward a tenant for selecting their space in a building that reduces their environmental impact due to the building's base building design attributes.	4	1
Land use and Ecology credits			4	1
Emissions Category				
Int-Emi-1	Impacts from refrigerants and insulants	To encourage and recognise developments that minimise light pollution into the night sky.	3	2
Int-Emi-2	Light Pollution	To encourage and recognise the avoidance of substances that contribute to the deterioration and long-term alteration of the Earth's atmosphere.	1,5	1,5
Emissions credits			4,5	3,5
Innovation Category				
Int-Inn-1	Innovative Strategies & Technologies	To encourage and recognise pioneering initiatives in sustainable design, process or advocacy.		2
Int-Inn-2	Exceeding Green Star SA Benchmarks	To encourage and recognise projects that achieve environmental benefits in excess of the current Green Star SA benchmarks.		1
Int-Inn-3	Environmental Design Initiatives	To encourage and recognise sustainable building initiatives that are currently outside of the scope of this Green Star SA rating tool but which have a substantial or significant environmental benefit.		2
Innovation credits			10	5
TOTAL POINTS AVAILABLE			100	80

Figure 7.29. Green Star Rating score (GBCSA, 2016).

GREEN STAR ASSESSMENT OUTCOME JUSTIFICATION

GBCSA CATEGORY	DESIGN APPLICATION / JUSTIFICATION OF POINTS AWARDED	POINTS
MANAGEMENT	<ul style="list-style-type: none"> > The design strategy aims to employ GBCSA professionals to accompany the design process to ensure implementation of sustainable building practices throughout the design and construction phase. > Management strategies aim to educate users and occupants of the space about the buildings sustainable initiatives. 	12.5
INDOOR ENVIRONMENTAL QUALITY (IEQ)	<ul style="list-style-type: none"> > The application of Biophilic design principles in the space aids the fulfilment of the IEQ requirements. Fresh air is circulated through the space through passive ventilation systems. > The large shopfront windows and the specification of SolaTubes allows the space to reap the benefits of natural lighting. > Ergonomics have been considered throughout the design creating a comfortable space for occupants. > The use of air-plants throughout the interior space improves indoor air quality and creates a connection between nature and the occupants. 	20
ENERGY	<ul style="list-style-type: none"> > Energy efficiency is achieved through employing processes that sequesters carbon and reduces greenhouse gases (i.e. closed-loop system). > The specification of photovoltaic solar panels to be installed on the roof supports the use of renewable energy sources. 	10
TRANSPORT	<ul style="list-style-type: none"> > Low points were scored in the Transport category since Irene Mall does not encourage the use of public transport since there are no formal bus terminals, taxi ranks or facilities that cater for cyclists. 	1
WATER	<ul style="list-style-type: none"> > Water saving fittings are included in the design strategy to reduce water consumption. > Additionally, a water metering system will be installed to allow the users of the space to monitor water consumption. 	5
MATERIALS	<ul style="list-style-type: none"> > Operational waste is reduced through the resource efficient design strategy. > A large percentage of the furniture and fittings specified is from renewable/ recycled resources. 	22
LAND USE	<ul style="list-style-type: none"> > Irene Mall as a whole does not employ sustainable practices. However the outdoor nature of the mall allows the stores to make use of natural light and ventilation contributing to the design strategy of Shop 150. 	1
EMISSIONS	<ul style="list-style-type: none"> > The store aims to prevent light pollution through minimising the use of artificial light. The maximum operating hours of the mall (09h00 to 20:00) does not allow for night time activity of retail stores, therefore indirectly reducing light pollution in the night. 	3.5
INNOVATION	<ul style="list-style-type: none"> > The design employs innovative design strategies such as Biomimicry and Biophilia that supports sustainable practices. 	5

Table 7.1. Green Star Rating Justification (Author, 2016).

7.5.2 SBAT RATING

The objective of the SBAT tool is to evaluate the design of the building in terms of sustainability. The tool measures the performance of the building according to the three pillars of sustainability including Social, Economic and Environmental influences. The outcome of the SBAT assessment on the design of Margaret Roberts skincare servicescape suggests that sustainable practices have indeed been employed. High scores are achieved for Adaptability, Efficiency, Material & Components and Occupant Comfort, which was part of the design strategy from the beginning. Unfortunately, lower scores are achieved for the Water and Participation & Control categories due to the fact that the site does not allow for water treatment plants and since the space is retail orientated, occupants do not have control over the interior environmental conditions. The score achieved in the Waste category is relatively high but was restricted since sewerage waste cannot be recycled on site.

(See Appendix for full SBAT report)

SUSTAINABLE BUILDING ASSESSMENT TOOL (SBAT- P) V1

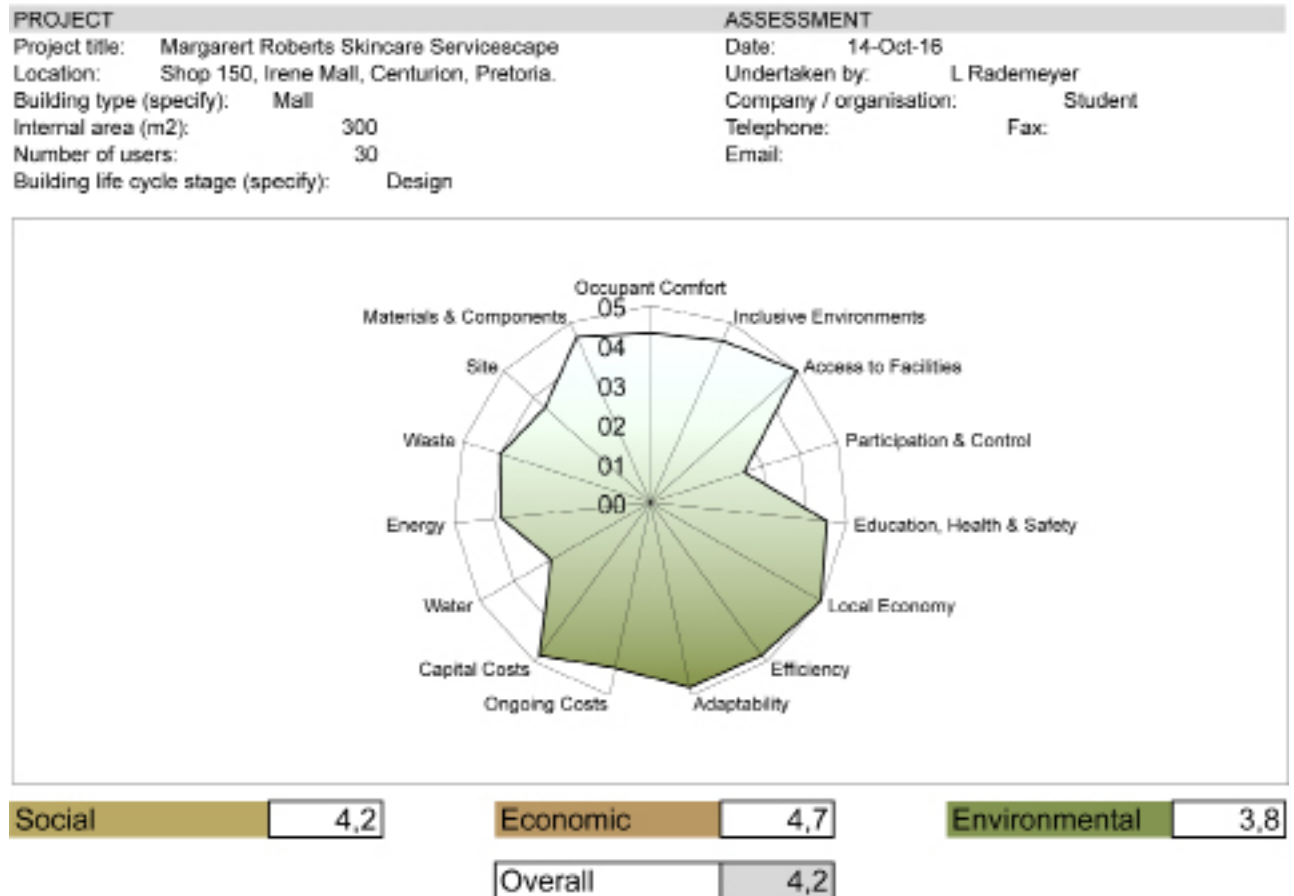
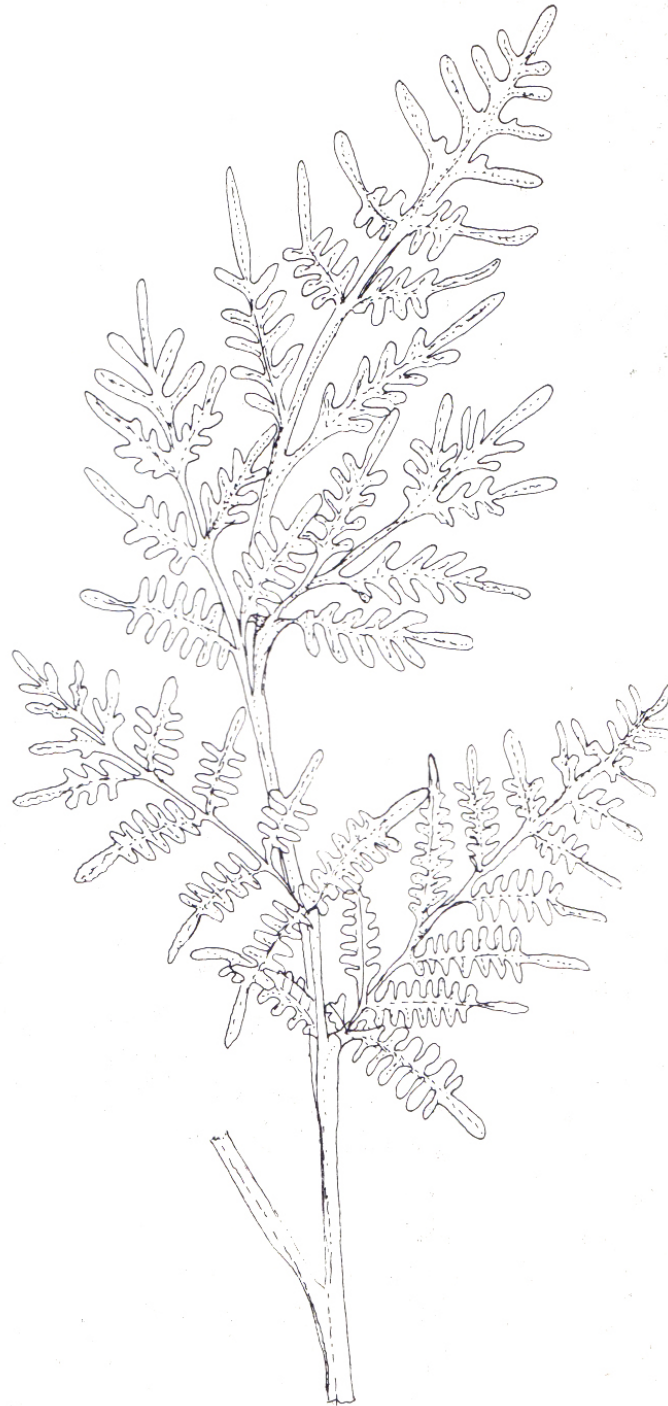

Figure 7.30. SBAT Rating Score (SBAT, 2016).



CONCLUSION

Final Reflections

08

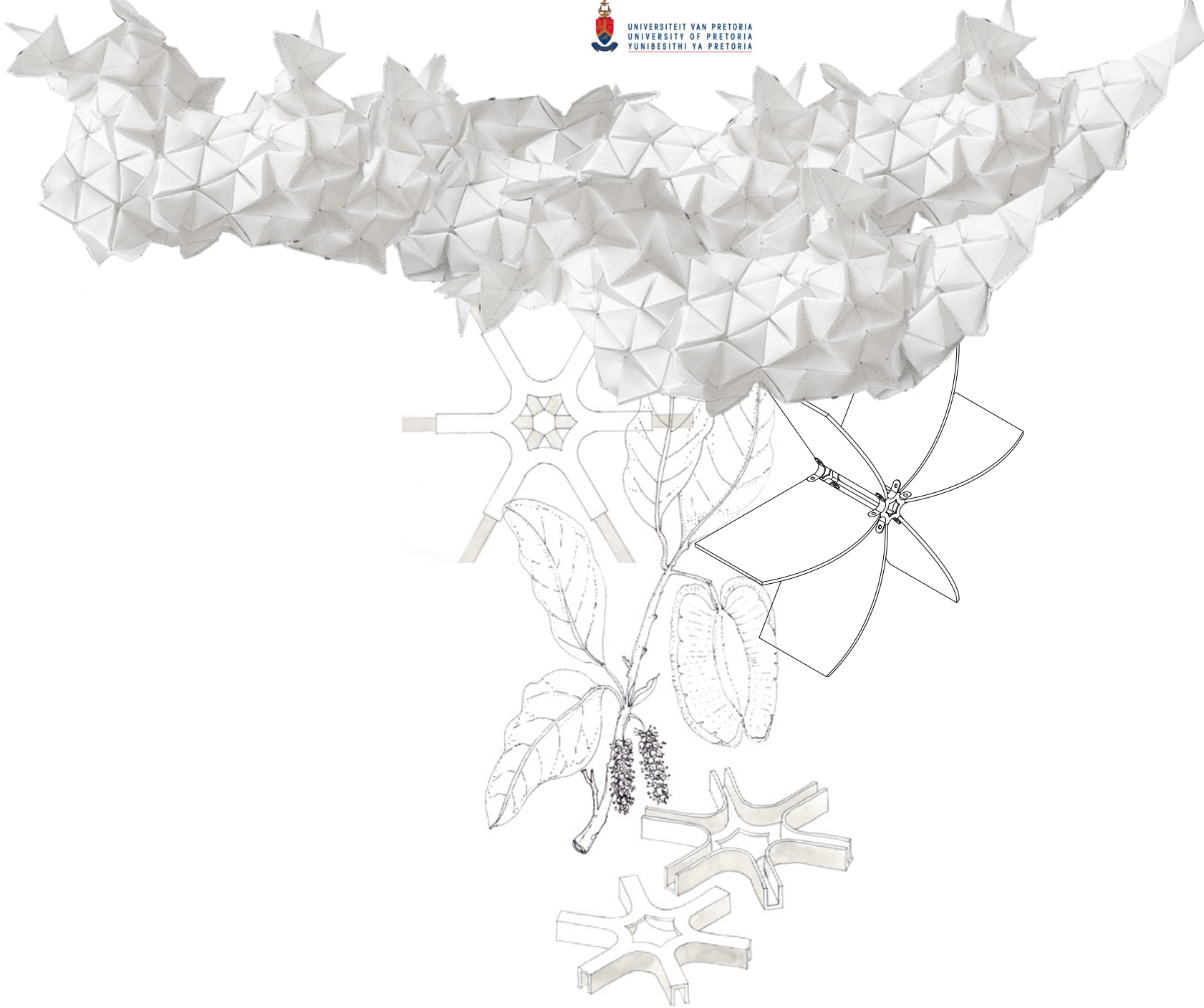

CONCLUSION

This dissertation investigated the design of a branded skincare servicescape for Margaret Roberts, influenced by nature as a model and mentor through the application of Biomimicry and Biophilic design theories.

In following the Biomimicry design principles, the design intervention was able to implement nature's resource efficient and zero-waste strategies towards creating a model for sustainable retail design. The potential environmental impact of the design solution was analysed using the Green Star Interior rating tool, which resulted in a '6 Star World Leadership' rating. This rating was achieved as a result of the implementation of Biomimicry and Biophilic principles.

Furthermore, Biophilic design theories paved the way for creating a retail experience that mimics the atmospheric qualities in nature. Creating a desired 'atmosphere' proved to be challenging since it is an intangible quality within a space and consequently very difficult to express. The application of Biophilic Patterns in the design intervention therefore guided the approach towards successful expression of the experiential qualities.

Through the implementation of Biomimicry and Biophilia, the design of Margaret Roberts' new proposed brand identity was able to evolve and develop into a contemporary product that sets itself apart from other competitors in the market through its sustainable and experiential characteristics.

As a whole, this dissertation contributed towards building a body of knowledge centred around nature-inspired design tools, including Biomimicry and Biophilia. Through research and design, this dissertation proved that both Biomimicry and Biophilia serve great value in the discipline of interior design, and offers a vast array of solutions to contemporary design problems.

LIST OF REFERENCES

Adams, Anne-Taylor. 2014. *Social Responsibility*. [Online]. Available: <http://www.nielsen.com/us/en/press-room/2014/global-consumers-are-willing-to-put-their-money-where-their-heart-is.html> [Accessed 03 Aug 2016].

Alcock, I., M.P. White, B.W. Wheeler, L.E. Fleming, & M.H. Depledge. 2014. *Longitudinal Effects on Mental Health of Moving to Greener and Less Green Urban Areas*. *Environmental Science & Technology*,

Alvarsson, J., S. Wiens & M. Nilsson. 2010. *Stress Recovery during Exposure to Nature Sound and Environmental Noise*. *International Journal of Environmental Research and Public Health*,

AskNature, 2015. *ZERI Coffee Farming System*. [Online]. Available: https://asknature.org/idea/zeri-coffee-farming-system/#.V_oabiN95FQ [Accessed 13 Aug 2016]

Barton, J. & J. Pretty 2010. *What Is the Best Dose of Nature and Green Exercise for Improving Mental Health*. *Environmental Science & Technology*,

Benyus, J. 1997. *Biomimicry: Innovation Inspired by Nature*. Harper Collins Publishers Inc: New York

Biomimicry 3.8, 2014. *Life's Principles*. [Online]. Available: <http://biomimicry.net/about/biomimicry/biomimicry-designlens/lifes-principles/> [Accessed 13 Aug 2016]

Bourke, P. 2001. *Fractals*. Available: <http://astronomy.swin.edu.au/prbourke/fractals/> [Accessed 03 Aug 2016]

Bradley, M. 2016. *Cardboard to Caviar*. [Online]. Available: <http://algalbiomass.weebly.com/graham-wiles-cardboard-to-caviar.html> [Accessed 13 Aug 2016]

Bradley, S. 2010. *The Meaning of Shapes: Developing Visual Grammar*. Available: <http://vanseodesign.com/web-design/visual-grammar-shapes/> [Accessed 10 Sept 2016]

Browning, W.D., Ryan, C.O., Clancy, J.O. 2014. *14 Patterns of Biophilic Design*. New York: Terrapin Bright Green llc.

Clanton, N. 2014. Clanton & Associates, Inc. Personal communication with the authors.

Davis, M. 2009. *The Fundamentals of Branding*. AVA Publishing SA: Switzerland.

Dykstra, P. 2008. *History of Environmental Movements*. [Online]. Available: http://edition.cnn.com/2008/TECH/science/12/10/history.environmental.movement/index.html?eref=rss_tech [Accessed 19 May 2016]

EPA. 2013. *Natural Resources: The Quest for Less*. [Online]. Available: http://www.epa.gov/osw/education/quest/pdfs/unit1/chap1/u1_natresources.pdf [Accessed 19 May 2015]

Haakdoorn Nursery. 2016. *Lavender – Margaret Roberts*. [Online]. Available: http://www.haakdoornnursery.co.za/product/lavender_margaret_roberts [Accessed 19 May 2016]

Heerwagen, J.H. 2006. *Investing In People: The Social Benefits of Sustainable Design*. Rethinking Sustainable Construction. Sarasota, FL.

Hussain, S. 2011. *The Impact of Sensory Branding on Consumers: A case study on KFC*. *International Journal of Research in Business Management*.

Jones, L. 2008. *Environmentally Responsible Design*. Canada: John Wiley & Sons, Inc.

Justema, W. 1982. *The Pleasures of Pattern*. Van Nostrand Reinold: New York.

Kapferer, Jean-Noël. 2012. *The Luxury Strategy: Break the Rules of Marketing to Build Luxury Brands*. Philadelphia, PA: London.

Kellert, S.F., J.H. Heerwagen, & M.L. Mador Eds. 2008. *Biophilic Design: The Theory, Science & Practice of Bringing Buildings to Life*. Hoboken, NJ: John Wiley & Sons.

Kotler, P. 1974. *Atmospherics as a Marketing Tool*. Illinois: Northwestern University. 48-64.

Leone, C.W. 2008. *Come to Your Senses*. Perspring: Architempts. 35-43.

Li, Q., M. Kobayashi, H. Inagaki, Y. Wakayama, M. Katsumata, Y. Hirata, Y. Li, K. Hirata, T. Shimizu, A.

Nakadai, & T. Kawada 2012. *Effect of Phytoncides from Forest Environments on Immune Function*. In Q. Li (Ed.). Forest Medicine ebook: Nova Science Publishers.

Magdof, F. 2013. Global Resource Depletion. [Online]. Available: http://www.hst.org.za/uploads/files/chap13_07.pdf [Accessed 19 May 2016]

Margaret Roberts. n.d. The Herbal Centre. [Online]. Available: <http://www.margaretroberts.co.za/index.htm> [Accessed 15 July 2016]

McDonough & Braungart, 2000). *Cradle to Cradle: Remaking the way we make things*. London: Vintage.

Mesher, L. 2010. *Basics Interior Design: Retail Design*. AVA Publishing SA: Switzerland.

Neidlinger, J. 2016. *The Ultimate Guide to Using Colour Psychology in Marketing*. [Online]. Available: <http://coschedule.com/blog/color-psychology-marketing/> [Accessed 03 Aug 2016]

Nicklas, M.H. & G.B. Bailey 1996. *Student Performance in Daylit Schools*. [Online]. Available <http://www.innovativedesign.net/Profile-Resources-Technical-Papers.html> [Accessed 03 Aug 2016]

Nicolae, I. 2011. *The Psychology of Colour for Interior Design*. [Online]. Available: <http://designlike.com/the-psychology-of-color-for-interior-design/> [Accessed 03 Aug 2016]

Nordqvist, J. 2014. *Health Benefits of Lavender*. [Online]. Available: <http://www.medicalnewstoday.com/articles/265922.php> [Accessed 19 May 2016]

Park, B.J., Y. Tsunetsugu, T. Kasetani, T. Morikawa, T. Kagawa, & Y. Miyazaki 2009. *Physiological Effects of Forest Recreation in a Young Conifer Forest in Hinokage Town, Japan*. Silva Fennica,

Pawlyn, M. 2011. *Biomimicry in Architecture*. RIBA Publishing: London.

Pine, BJ & Gilmore, JH. 1998. *Welcome to the experience economy*. [Online]. Available: http://www.hospitality.ucf.edu/faculty/raywang/HFT_6938/Experiential%20consumption/WelcomeToExperienceEconomy.pdf [Accessed 05 Nov 2016].

Reiwoldt, O. 2002. *Brandscaping: Worlds of Experience in Retail Design* Birkha user,

Schumacher, E.F 1973. *Small is Beautiful. Economics as if People Mattered*. New York: Harper and Row

The World Counts. 2015. *Consequences of Depletion of Natural Resources*. [Online]. Available: http://www.theworldcounts.com/stories/consequences_of_depletion_of_natural_resources [Accessed 19 May 2016]

van den Berg, A.E., Y. Joye, & S. de Vries 2007. *Health Benefits of Nature*. In: L. Steg, A.E. van den Berg, & J.I.M. de Groot (Eds.), *Environmental Psychology: An Introduction* (47-56). First Edition. Chichester: Wiley- Blackwell.

Wheeler, A. 2009. *Designing Brand Identity*. John Wiley & Sons Inc: New Jersey.

Wigo, H. 2005. *Technique and Human Perception of Intermittent Air Velocity Variation*. KTH Research School, Centre for Built Environment.

Zanowick, M.B. 2012. *Biomimicry: Nature's Time Tested Framework for Sustainability*. Available: <http://peakstoprairies.org/media/Biomimicry-Overview.docx> [Accessed 05 May 2016]

Zuidhof, J. 2007. *3D In-store Design towards meaningful brand experiences in in physical in- store environments*. Netherlands: University of Twente.

FIGURE REFERENCES

Advanced Building, 2012. Waterkloof Corner Shopping Centre. [Online]. <http://www.advanced-building.org/waterkloof-corner-shopping-centre/> [Accessed 13 Aug 2016]

Air Plant Supply, 2016. Air plants. [Online]. <http://www.airplantsupplyco.com/collections/wholesale/products/wholesale-harrisii-minimum-order-of-12-plants> [Accessed 13 Aug 2016]

ArchiTonic, 2013. Seating Armchairs. [Online]. <https://www.architonic.com/en/product/zimmer-rohde-club-chair/1190961> [Accessed 13 Aug 2016]

AskNature, 2016. AskNature Resources. [Online]. <https://asknature.org/> [Accessed 13 Aug 2016]

Bunnings, 2016. Bunnings Warehouse. [Online]. https://www.bunnings.co.nz/handy-storage-5-tier-1830x-910x400mm-shelving-unit_p00991345 [Accessed 13 Aug 2016]

Cochrane, S. 2015. Summer Fruit. [Online]. <http://shaycochrane.com/blog/2015/03/03/in-the-shop-summer-fruit-styled-stock/> [Accessed 13 Aug 2016]

Etsy, 2007. Nature Photography Prints. [Online]. https://www.etsy.com/shop/RockyTopPrintShop?section_id=8129994 [Accessed 13 Aug 2016]

Fetrow, K. 2011. Searching Safe Energy. [Online]. <http://subversify.com/2011/04/08/obama%E2%80%99s-energy-plan%E2%80%99s-dirty-secrets/> [Accessed 13 Aug 2016]

Flickrriver, 2006. Wood Weave. [Online]. <http://www.flickrriver.com/photos/visionairy/309338843/> [Accessed 13 Aug 2016]

Gardeners, 2014. Aroma Oil Diffuser. [Online]. <http://www.gardeners.com/buy/ultrasonic-aromatherapy-oil-diffuser/> [Accessed 13 Aug 2016]

Gombikova, Z. 2014. Health Effects of Light. [Online]. <https://freyaled.com/en/blog/health-effects-of-the-light> [Accessed 13 Aug 2016]

Howarth, D. 2015. Fairphone Amsterdam Offices. [Online]. <http://www.dezeen.com/2015/06/24/fairphone-amsterdam-offices> [Accessed 13 Aug 2016]

Kostreva, J. 2016. Crashing Waves. [Online]. <http://blog.juliakostreva.com/page/2/> [Accessed 13 Aug 2016]

Margolis, M. 2016. Drought Tolerant Garden. [Online]. <http://www.houzz.com/ideabooks/3352661/thumbs/www.houzz.com/ideabooks/3352661/list/Drought-Tolerant-Garden> [Accessed 13 Aug 2016]

Pixel, P. 2013. Architecture from around the World. [Online] <http://snappypixels.com/interesting/cool-architecture-around-world/> [Accessed 13 Aug 2016]

Schmidt, P. 2016. Scethno Inteiror. [Online] <http://www.heimatbaum.com/scethno-interior-vom-feinsten/> [Accessed 13 Aug 2016]

Snowy River Lavender, 2016. Composting Lavender. [Online] <http://snowyriverlavender.com.au/composting-lavender/> [Accessed 13 Aug 2016]

Solatube, 2016. Southdowns Shopping Centre. [Online] <http://www.southdownscentre.co.za/> [Accessed 13 Aug 2016]

Southdowns, 2016. SolaMaster Series. [Online] <http://solatube.co.za/solamaster-series/> [Accessed 13 Aug 2016]

StudioChoo, 2010. Fungi Growth. [Online] <http://www.designsponge.com/2011/02/we-like-it-wild-fungi-love.html/pioppini> [Accessed 13 Aug 2016]

Panero, J & Zelnik, M. 1979. Human Dimension and Interior Space. Canada: Whitney Library of Design.

Verdina, A. 2013. Berries. [Online]. <https://www.flickr.com/photos/58739058@N07/9648768356/> [Accessed 13 Aug 2016]

VivreDemain, 2016. Lavender Harvesting. [Online] <http://vivredemain.fr/recolte-lavande-photos/> [Accessed 13 Aug 2016]

APPENDIX A

SBAT SCORING SHEETS

Performance - Social

Indicator	Indicative performance measure	Measured	Points
Indicative performance measure			
		<u>Explanatory notes</u>	4,3
Daylight	% of occupied spaces that are within distance 2H from window, where H is the height of the window or where there is good daylight from skylights	70	0,7
Acoustic	% of occupied spaces have equivalent of opening window area equivalent to 10% of floor area or adequate mechanical system, with unpolluted air source	100	1,0
	% of occupied spaces where external/internal/reverberation noise does not impinge on normal conversation (50dbA)	100	1,0
Thermal comfort	Temperature of occupied space does not exceed 28 or go below 19°C for less than 5 days per year (100%)	100	1,0
	% of occupied space that is 6m from an external window (not a skylight) with a view	60	0,6
		<u>Explanatory notes</u>	4,5
Transport	% of building (s) within 400m of disabled accessible (20%) and affordable (80%) public transport	100	1,0
Wayfinding	Comprehensive signage provided (50%), Signage high contrast, clear print signage in appropriate locations and language(s) / use of understandable symbols / manned reception at all entrances (50%)	100	1,0
	% of occupied spaces that are accessible to ambulant disabled / wheelchair users	70	0,7
	% of occupied space with fully accessible toilets within 50m along easily accessible route	100	1,0
Accessibility & Furniture	% of commonly used furniture and fittings (reception desk, kitchenette, auditorium) fully accessible	80	0,8
		<u>Explanatory notes</u>	5,0
Proximity	All users can walk (100%) / use public transport (50%) to get to their childrens' schools and creches	100	1,0
Banking	All users can walk (100%) / use public transport (50%) to get to banking facilities	100	1,0
Food retail	All users can walk (100%) / use public transport (50%) to get to food retail	100	1,0
Communication	All users can walk (100%) / use public transport (50%) to get to communication facilities (post/telephone/internet)	100	1,0
Recreation	All users can walk (100%) / use public transport (50%) to get to recreation/exercise facilities	100	1,0
		<u>Explanatory notes</u>	2,5
Thermal control	% of occupied space able to control their thermal environment (adjacent to openable windows/thermal controls)	0	0,0
Light control	% of occupied space able to control their light (adjacent to controllable blinds etc/local lighting control)	0	0,0
Meeting spaces	Social informal meeting spaces (parks / staff canteens / cafes) provided locally (within 400m) (100%)	100	1,0
Shared facilities	5% or more of facilities shared with other users / organisations on a weekly basis (100%)	100	1,0
Participation	Users actively involved in the design process (50%) / Active and representative management user group (50%)	50	0,5
		<u>Explanatory notes</u>	4,5
Education	Two percent or more space/facilities available for education (seminar rooms / reading / libraries) per occupied space (75%). Construction training provided on site (25%)	50	0,5
Security	All well used routes in and around building well lit (25%), all routes in and around buildings visually supervised (25%), secure perimeter and access control (50%), No crime (100%)	100	1,0
Health & Safety	% of users who can access information on health & safety issues (ie HIV/AIDS), training and employment opportunities easily (posters/personnel/intranet site)	100	1,0
Indoor Air Quality	All materials/components used have no negative effects on indoor air quality (100%)	100	1,0

Building Performance - Economic

	Criteria	Indicative performance measure	Measured	Points
EC 1	Local economy		<u>Explanatory notes</u>	5.0
EC 1.1	Local contractors	% value of the building constructed by local (within 50km) small (employees<20) contractors	100	1.0
EC 1.2	Local materials	% of materials (sand, bricks, blocks, roofing material) sourced from within 50km	100	1.0
EC 1.3	Local components	% of components (windows, doors etc) made locally (in the country)	100	1.0
EC 1.4	Local furniture/fitings	% of furniture and fittings made locally (in the country)	100	1.0
EC 1.5	Maintenance	% of maintenance and repairs by value that can, and are undertaken, by local contractors (within 50km)	100	1.0
EC 2	Efficiency		<u>Explanatory notes</u>	4.8
EC 2.1	Capacity	% capacity of building used on a daily basis (actual number of users / number of users at full capacity*100)	90	0.9
EC 2.2	Occupancy	% of time building is occupied and used (actual average number of hours used / all potential hours building could be used (24)*100)	100	1.0
EC 2.3	Space per occupant	Space provision per user not more than 10% above national average for building type (100%)	90	0.9
EC 2.4	Communication	Site/building has access to internet and telephone (100%), telephone only (50%)	100	1.0
EC 2.5	Material & Components	Building design coordinated with material / component sizes in order to minimise wastage. Walls (50%), Roof and floors (50%)	100	1.0
EC 3	Adaptability		<u>Explanatory notes</u>	4.1
EC 3.1	Vertical heights	% of spaces that have a floor to ceiling height of 3000mm or more	90	0.9
EC 3.2	External space	Design facilitates flexible external space use (100%)	100	1.0
EC 3.3	Internal partition	Non loadbearing internal partitions that can be easily adapted (loose partitioning (100%), studwall (50%), masonry (25%)	50	0.5
EC 3.4	Modular planning	Building with modular structure, envelope (fenestration) & services allowing easy internal adaptaptation (100%)	80	0.8
EC 3.5	Furniture	Modular, limited variety furniture - can be easily configured for different uses (100%)	90	0.9
EC 4	Ongoing costs		<u>Explanatory notes</u>	4.3
EC 4.1	Induction	All new users receive induction training on building systems (50%), Detailed building user manual (50%)	100	1.0
EC4.2	Consumption & waste	% of users exposed on a monthly basis to building performance figures (water (25%), electricity (25%), waste (25%), accidents (25%)	80	0.8
EC 4.2	Metering	Easily monitored localised metering system for water (50%) and energy (50%)	100	1.0
EC4.3	Maintenance & Cleaning	% of building that can be cleaned and maintained easily and safely using simple equipment and local non-hazardous materials	50	0.5
SO 4.5	Procurement	% of value of all materials/equipment used in the building on a daily basis supplied by local (within the country) manufacturers	100	1.0
EC 5	Capital Costs		<u>Explanatory notes</u>	4.8
EC 5.1	Local need	Five percent capital cost allocated to address urgent local issues (employment, training etc) during construction process (100%)	100	1.0
EC5.2	Procurement	Tender / construction packaged to ensure involvement of small local contractors/manufacturers (100%)	100	1.0
EC 5.3	Building costs	Capital cost not more than fifteen % above national average building costs for the building type (100%)	100	1.0
EC5.4	Technology	3% or more of capital costs allocated to new sustainable/indigenous technology (100%)	80	0.8
EC 5.5	Existing Buildings	Existing buildings reused (100%)	100	1.0

Building Performance - Environmental

	Criteria	Indicative performance measure	Measured	Points
EN 1	Water		Explanatory notes	2,9
EN 1.1	Rainwater	% of water consumed sourced from rainwater harvested on site	0	0,0
EN 1.2	Water use	% of equipment (taps, washing machines, urinals showerheads) that are water efficient	100	1,0
EN 1.3	Runoff	% of carparking, paths, roads and roofs that have absorbant/semi absorbant/permeable surfaces (grassed/thatched/looselaid paving/ absorbant materials)	60	0,6
EN 1.4	Greywater	% of water from washing/relatively clean processes recycled and reused	40	0,4
EN 1.5	Planting	% of planting (other than food gardens) on site with low / appropriate water requirements	90	0,9
EN 2	Energy		Explanatory notes	3,8
EN 2.1	Location	% of users who walk / cycle / use public transport to commute to the building	50	0,5
EN 2.2	Ventilation	% of building ventilation requirements met through natural / passive ventilation	70	0,7
EN 2.3	Heating & Cooling	% of occupied space which relies solely on passive environmental control (no or minimal energy consumption)	80	0,8
EN 2.4	Appliances & fittings	% of appliances / lighting fixtures that are classed as highly energy efficient (ie energy star rating)	100	1,0
EN 2.5	Renewable energy	% of building energy requirements met from renewable sources	80	0,8
EN 3	Waste		Explanatory notes	4,0
EN 3.1	Toxic waste	% of toxic waste (batteries, ink cartridges, flourescent lamps) recycled	100	1,0
EN 3.2	Organic waste	% of organic waste recycled	100	1,0
EN 3.3	Inorganic waste	% of inorganic waste recycled.	100	1,0
EN 3.4	Sewerage	% of sewerage recycled on site	0	0,0
EN 3.5	Construction waste	% of damaged building materials / waste developed in construction recycled on site	100	1,0
EN 4	Site		Explanatory notes	3,6
EN 4.1	Brownfield site	% of proposed site already disturbed / brownfield (previously developed)	100	1,0
EN 4.2	Neighbouring buildings	No neighbouring buildings negatively affected (access to sunlight, daylight, ventilation) (100%)	100	1,0
EN 4.3	Vegetation	% of area of area covered in vegetation (include green roofs, internal planting) relative to whole site	60	0,6
EN 4.4	Food gardens	Food gardens on site (100%)	0	0,0
EN 4.5	Landscape inputs	% of landscape that does not require mechanical equipment (ie lawn cutting) and or artificial inputs such as weed killers and pesticides	100	1,0
EN 5	Materials & Components		Explanatory notes	4,6
EN 5.1	Embodied energy	Materials with high embodied energy (aluminium,plastics) make up less than 1% of weight of building (100%)	90	0,9
EN 5.2	Material sources	% of materials and components by volume from grown sources (animal/plant)	90	0,9
EN 5.3	Ozone depletion	No materials and components used requiring ozone depleting processes (100%)	90	0,9
EN 5.4	Recyled / reuse	% of materials and components (by weight) reused / from recycled sources	90	0,9
EN 5.5	Construction process	Volume / area of site disturbed during construction less than 2X volume/area of new building (100%)	100	1,0

APPENDIX B

PHOTOS FROM FINAL EXAM



