

## 5. MAKING PLACE

*Concept to design refinement*



The preceding chapters have described the theoretical, programmatic, contextual and conceptual informants which underpin the dissertation intentions, and guide the design development. This chapter will present the synthesis of these components alongside the physical exploration of these notions. Although this process is not linear by nature, the body of work is arranged chronologically so the reader may be guided through the author's decision-making process. This is a process of using the *measurable* to create the *unmeasurable*.

## PREMISE

### *Finding the way*

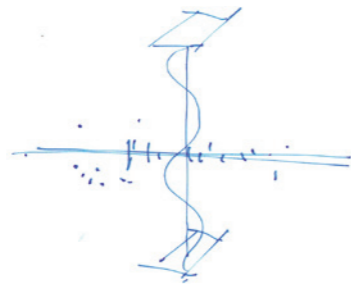

The underlying notion which has driven this study starts with the normative position, and questioning the role of young South African architects in the continuum of this discourse. This question developed into a response to the conditions discovered in Atteridgeville, which is reinforced by the desire to create beautiful architecture:

*"Those of us who have been trained as architects have this desire perhaps at the very centre of our lives: that one day, somewhere, somehow, we shall build one building which is wonderful, beautiful, breathtaking, a place where people can walk and dream for centuries."*

- Alexander (1979:9)

By investing this type of emotion into the design process, there is potential to create beautiful spaces which achieve what Alexander describes. Perhaps, if we adopt this approach, we will create beautiful spaces which give back to the community, and maybe, it will provide relief from the mundane. In light of our rushed lives in the name of progress and development, the simple and incredibly valuable aspects of what it is to be human are neglected. The study up until this point has investigated extensive theories and approaches to ensure the integrity of the project is upheld.

Fig. 160. Negotiating terrains.

## REVERIE

### *Conceptual ideas, notions, scenarios*

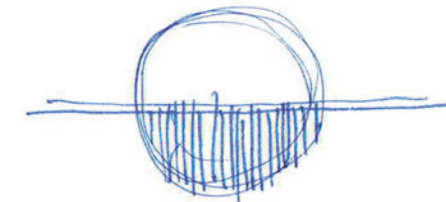

The design concept is an amalgam of the preceding literature review and contextual study. The aim is to translate these conceptual notions and scenarios into spatial approaches and devices by refining a conceptual response to inform space-making decisions.

The subject of investigation is the everyday. The extensive mapping and theoretical study acts as design generators and informants in an attempt to celebrate and enhance the quotidian by allowing for moments of serendipity and reverie.

The introduction of the selected programmes provides a new pattern of events to be hosted by a new surface for the extraordinary in the midst of the mundane.

Fig. 161. The realm between the mundane and the extraordinary.

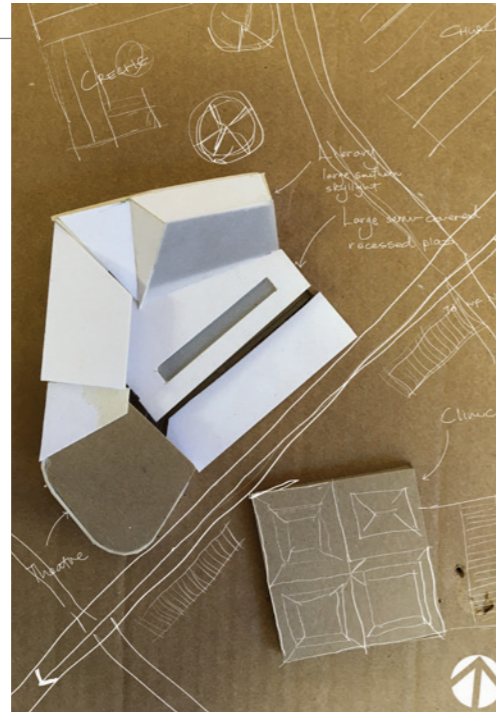

## MAKING SPACE

This iteration was the first formal response to the site. The exploration was informed by the act of 'making space' and containing activity in a large empty site within a dense suburban neighbourhood. The large recessed plaza provides a covered gathering space open to the public while the programme spaces define the outer limits of the site.

As an interpretation of a courtyard typology, this scheme severs a direct relationship with the street, preventing opportunities for cross-pollination between sites.

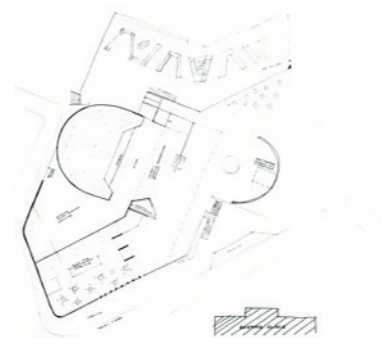
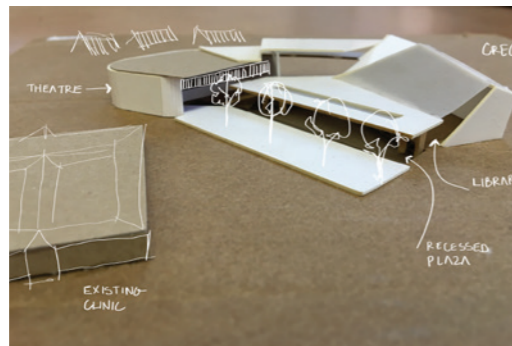
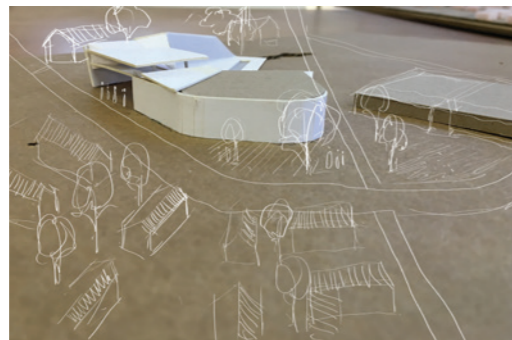
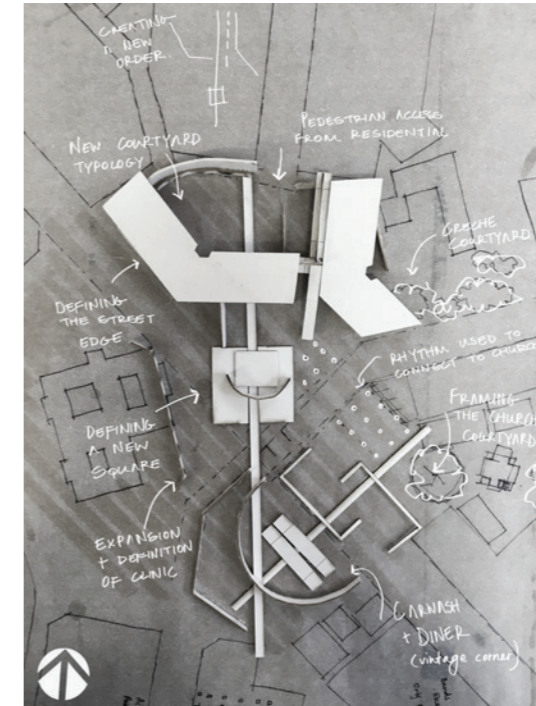

Fig. 162. Iteration I maquette 01 (Mar).  
Fig. 163. Iteration I maquette 02 (Mar).  
Fig. 164. Iteration I maquette 03 (Mar).  
Fig. 165. Plan interpretation (Apr).



## ROUTES + LEGIBILITY

This conceptual model exposes the search for a new order on the site. Responding to the existing forms, new connections were created across the ground plane, while using the vertical plane to create pockets of space on the vacant site. This exploration was mostly suggestive of the design intentions, but reappears later in the design process due to the success of these new connections and legibility.

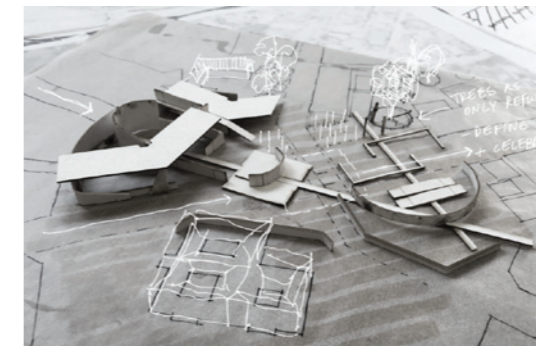
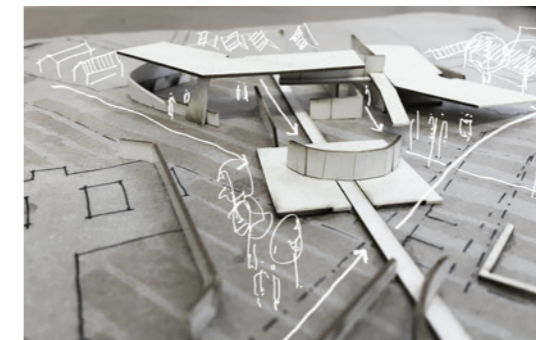
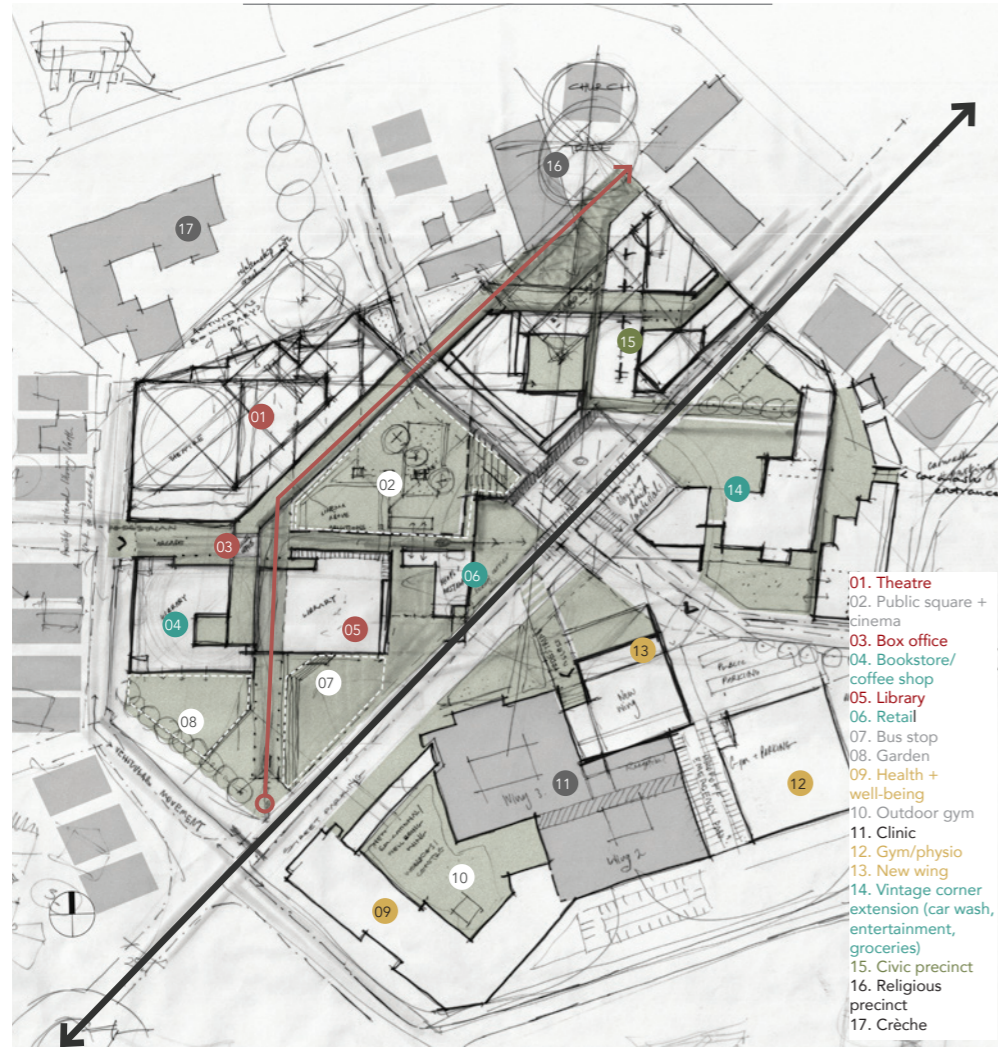

Fig. 166. Iteration II maquette 01 (Apr).  
Fig. 167. Iteration II maquette 02 (Apr).  
Fig. 168. Iteration II maquette 03 (Apr).

## SITE STRATEGY



■ Culture ■ Existing □ Public ■ Culture ■ Retail ■ Civic

**Fig. 169.** Iteration III. The above iteration is informed by an adapted street typology creating a new route between the cultural precinct and the church. The public square is screened from the busy street edge and smaller gardens and courtyards are provided. Existing programmes are retained, allowing for growth and densification. The intention is to create a clearly defined civic node

## SITE INTENTIONS



■ Culture ■ Existing □ Public ■ Culture ■ Retail ■ Civic

**Fig. 170.** Iteration III. The articulation of edge conditions is vital to successfully connect the various supporting spaces. The relationship between light and greenery is used as a tool to tie spaces together. Surface treatment in the public spaces will aid in defining the new routes, and blur the boundaries between inside and outside. The new configuration and extension of the clinic allows for an integration into the series of public spaces. These decisions were informed by the *activity, interface and connect* intentions identified in Volume I.

## REFLECTION

### *Fragmentation and mediation*

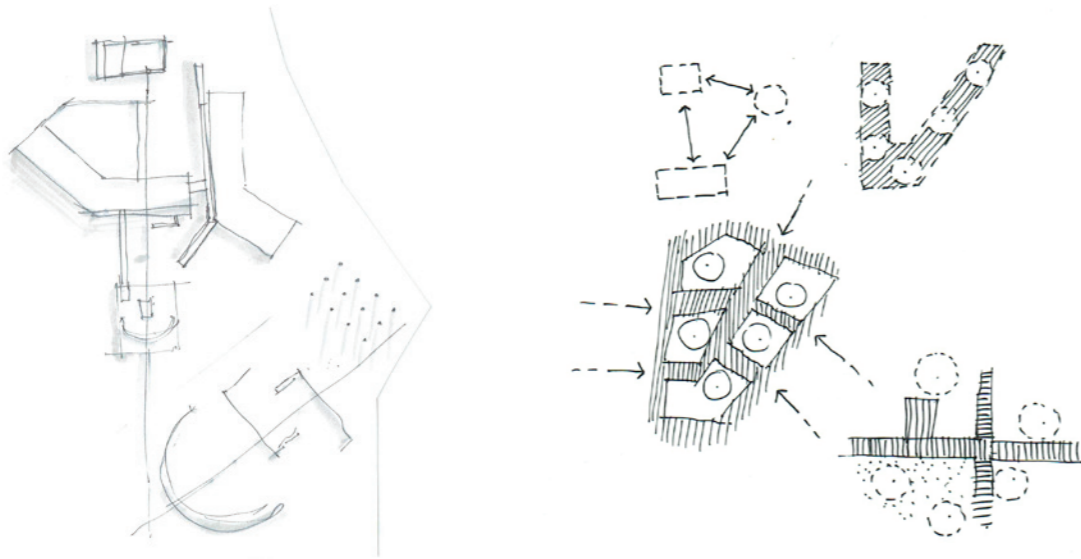

The design development has investigated the relationship between the different programmes with one another and with the existing programmes on site. The challenge was to understand whether a single form containing all the programmes framing a large public space was appropriate or whether a series of forms dispersed independently across the site connected by narrow avenues would be more appropriate. At this stage, Iteration II was referred to in order to develop a mediation between the fragmented schemes of Iteration III, and a legible ordering system. The notion of public intimacy was the main informant leading to the decision to create a campus typology for the various programmes with a layering of public spaces.

Fig. 171. Sketch of early maquette

Fig. 172. Interrogating street typologies.

## INDOOR STREETS

### *Routes and the third place*

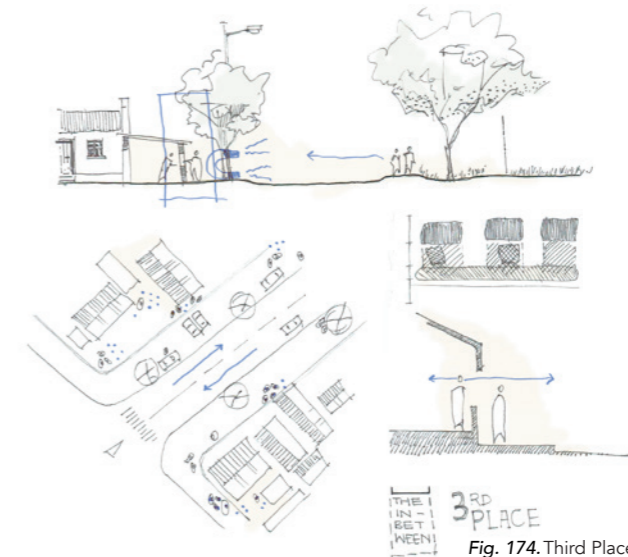

Fig. 174. Third Place in Atteridgeville.

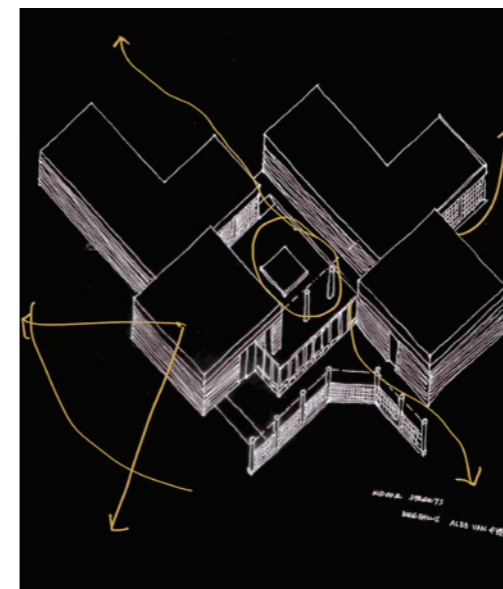

Fig. 173. Sketch of van Eyck's indoor streets.

To discover an appropriate typology, the *third place* condition identified in Atteridgeville was reconsidered. How could this articulation of the private and public realm in relation to the street be recreated at a larger scale for public buildings?

This thinking was in-line with the approach taken by Aldo van Eyck for the Amsterdam Orphanage. Van Eyck created many in-between conditions in the building, which interrupts the hierarchy of spaces. A large, decentralised node with many points of interaction provided a non-hierarchical scheme for the orphanage (Righini 1999:127-9).

This led to the thorough investigation of pockets of space along a route using the metaphor of the indoor street on the following pages.

## THE ROUTE

### *Understanding relationships*

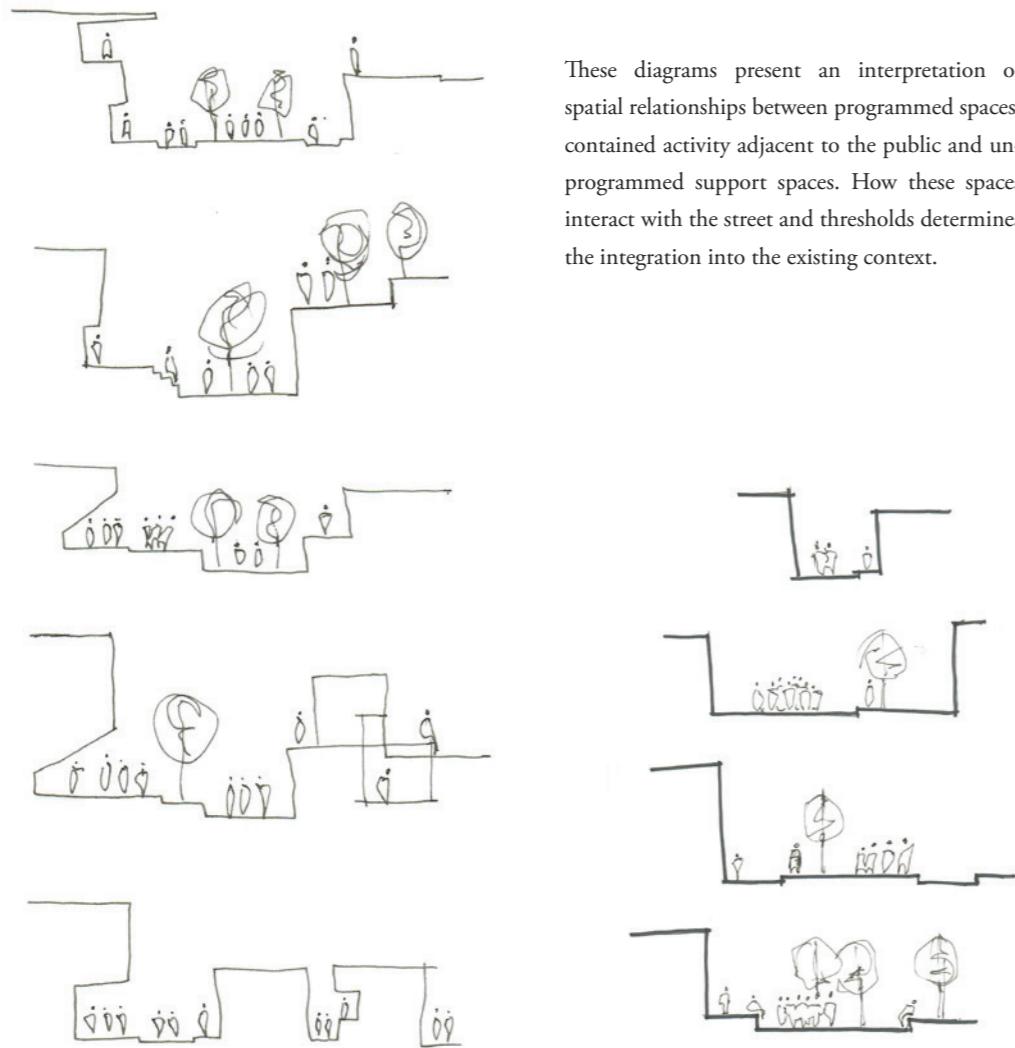

Fig. 175. Interaction on the street (May).

Fig. 176. Shared spaces (May).

## SERENDIPITY

### *Movement as space*

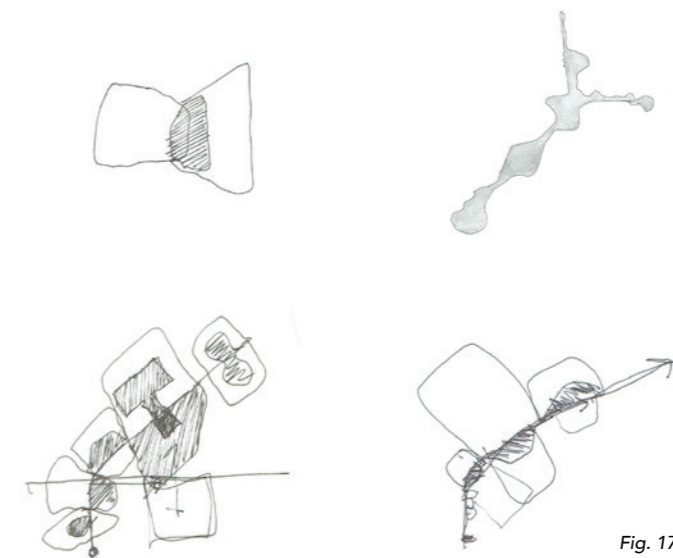
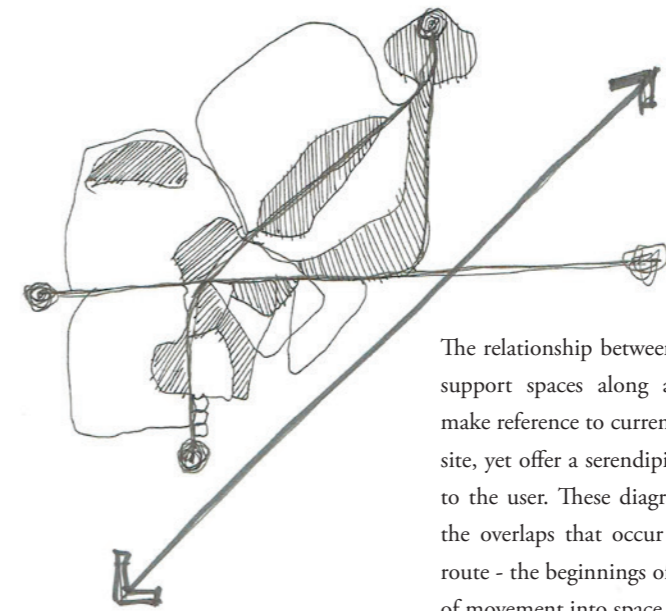

Fig. 177. The route (May).

## LAYERS

### *Understanding relationships*

Creating a geography of real and imagined spaces allows the designer to develop relationships with the site allowing for a richer interpretation of existing conditions. The diagrams on this page form part of the analysis of the grid and the street of Ramohoebo Square as an attempt to uncover the latent potential of the empty portion of site.

The existing urban structure is identified (1) and then the presence of the active programmes is indicated (2,3). An island of potential energy is outlined and relationships or overlaps suggest gathering spaces and alleys (4,5,6). A mediation of scale is proposed, followed by a new collection of places.

By uncovering these layers, it was evident that a new structure was required to bring these elements together. The image on the opposite page presents a new pattern to be superimposed onto the site developed from the existing patterns identified.

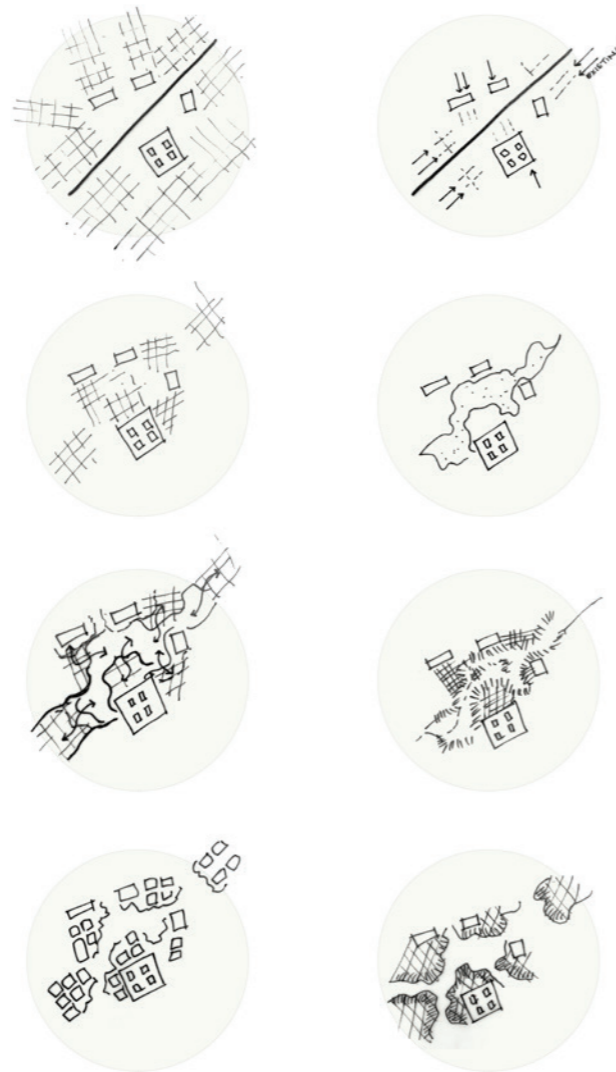
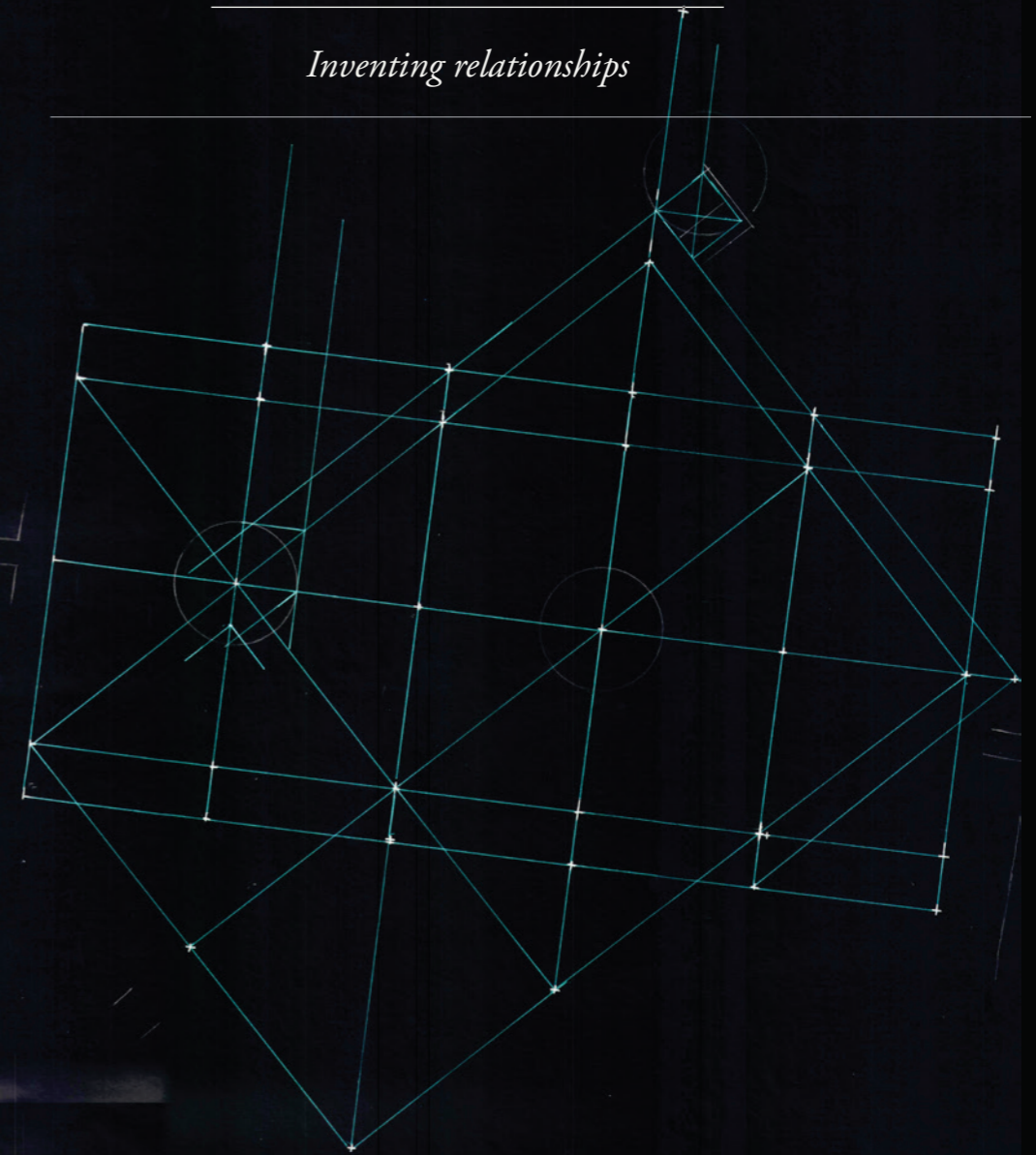

Fig. 178. Structure and overlap (May).

Fig. 179. New Patterns (opposite), (May).

## LAYERS

### *Inventing relationships*



TO ACHIEVE ANYTHING WE HAVE TO INVENT RELATIONSHIPS.  
CARLO SCARPA (1976)

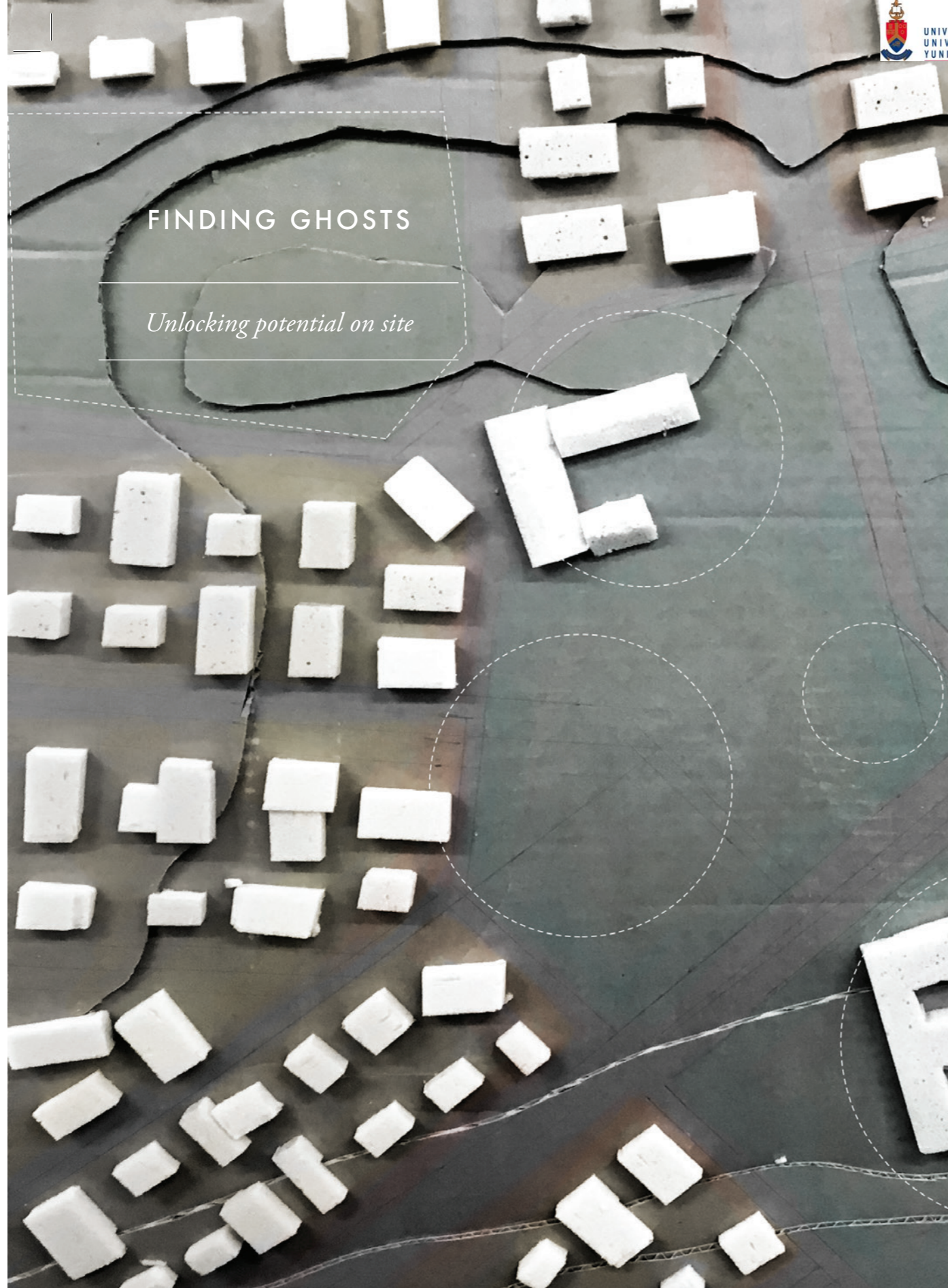

Fig. 180. The empty square and all the houses.





Fig. 181. Pattern and mass (May).



Fig. 183. Intimacy and mass (May).

## INTIMACY

### *Massing patterns*

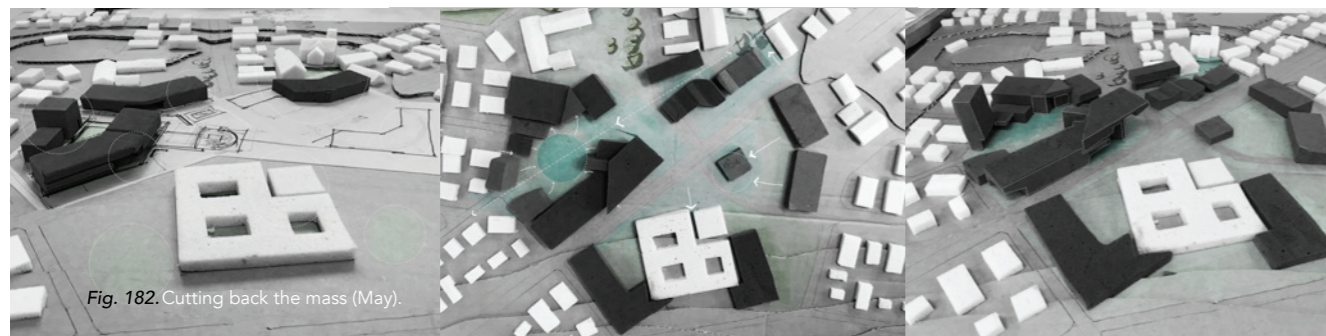
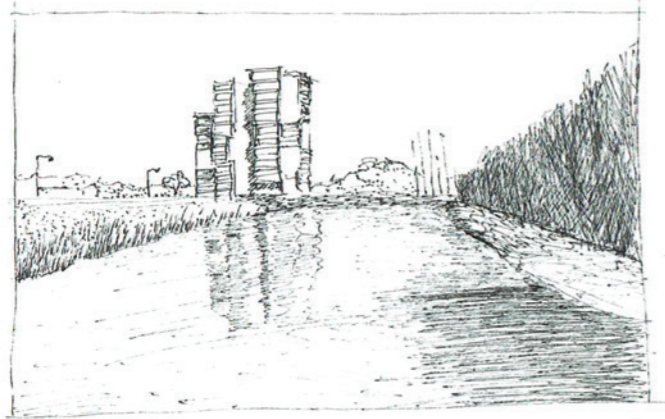

Fig. 182. Cutting back the mass (May).

Models were used as a physical interpretation of the new pattern proposed for Ramohoebo Square. The massing exposes the areas which offer intimate and exposed experiences in relation to the programmed space. A clear connection has been established with the eastern civic precinct while pauses are offered along the route.



## FINDING FORM

### *Public buildings*

The following images form a study of public buildings understood through drawing. These buildings were selected based on scale, programme, their contribution to the public realm and form.

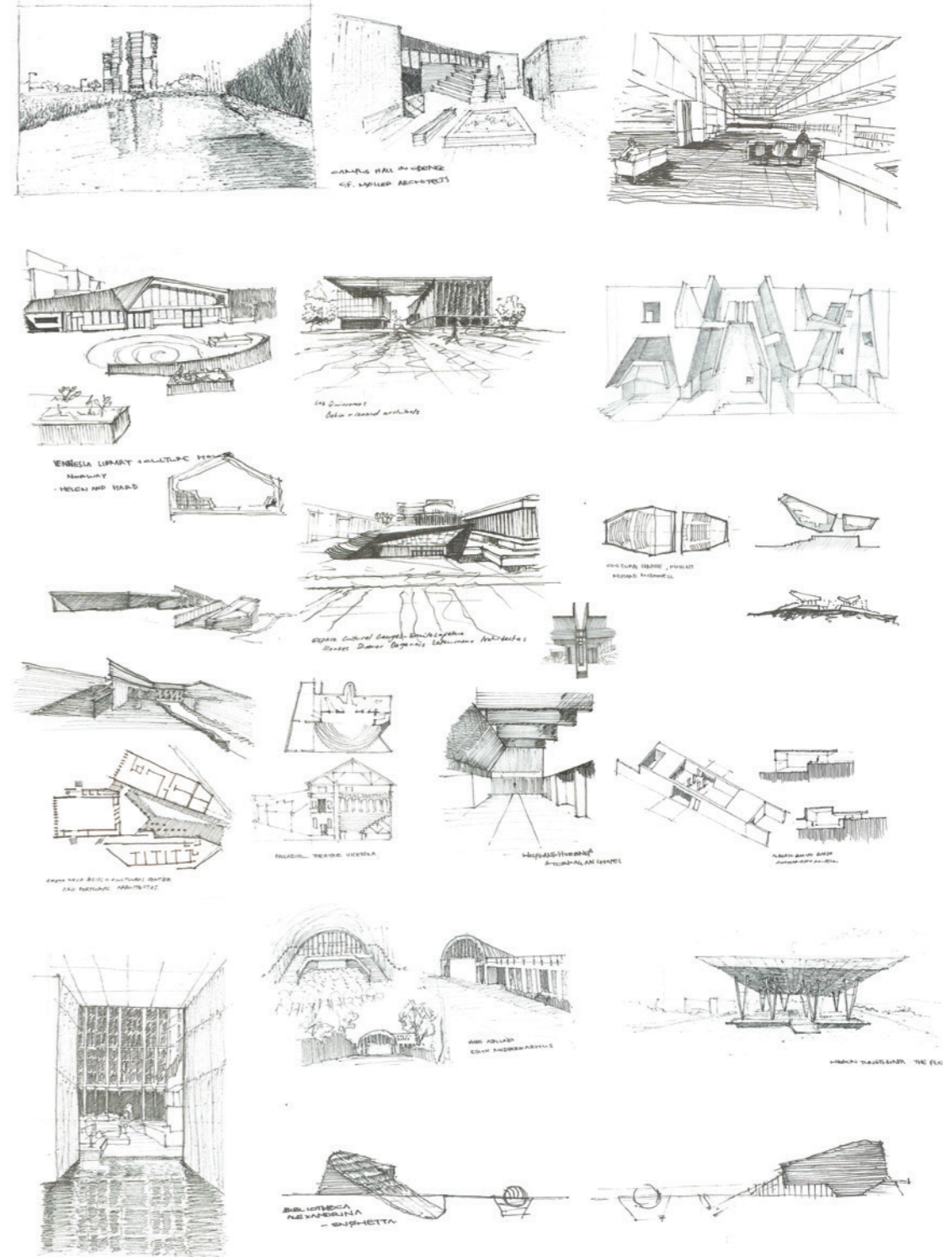
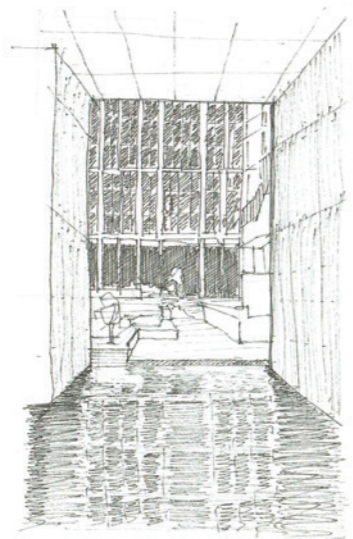

Fig. 184. Drawing public buildings.

## COURTYARDS

### *Testing typologies*

The diagrams to the right represent the early configuration of the site. The original mass model was manipulated to develop an articulated courtyard space. The metaphor of the 'indoor street' is constantly referenced to create harmony across the site, and define the relationships between the various programmes.

Main public entrances to the square are placed to respond to the programmes outside of the new cultural precinct, making reference to the relationships established by the new patterns imposed onto the site. This allows for an easily accessible public space, although it is protected from the busy Mareka street. The intention is to provide a space by which the user is immediately aware that they have crossed the threshold into a new experience.

The various programmes have been arranged according to a hierarchy of intimacy as one moves to the northern portion of the site, while the edge conditions offer a more vibrant interaction.

The proposal for the courtyard responds to a need identified during the contextual study. Currently the streets of Atteridgeville host a variety of activities but this precinct would cater for places of gathering and facilitate happenings not possible on the sidewalk or street. The configuration allows for a 'slowing down' before entering the new precinct which responds to the conceptual intentions.



Fig. 185. Courtyard 01 (May). Grading experience from the public to the private



Fig. 186. Courtyard 02 (May). Clear definition of courtyard space and potential for points of permeability.



Fig. 187. Courtyard 03 (May) - programmatic considerations in response to courtyard typology.

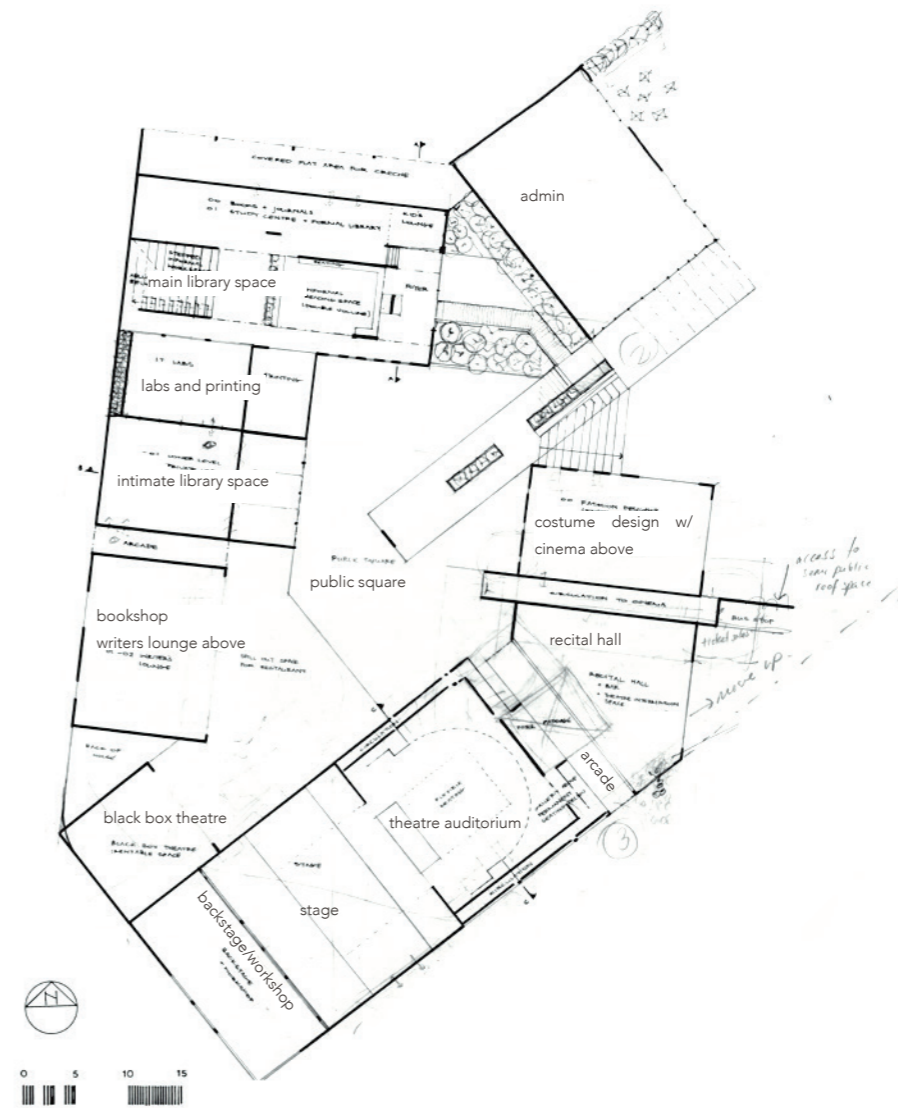

Fig. 188. Iteration IV (June). Translation of mass model into plan diagram establishing relationship between programme and space.

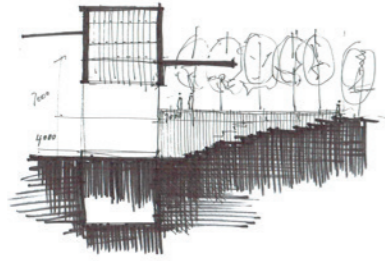

Fig. 189. Theatre diagram: scale and public interface.

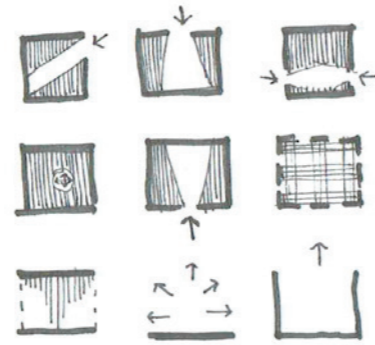

Fig. 190. Light and the contribution to spatial qualities enhancing the experience of getting lost.

## DRAWING

### *Exploring space making*

These images form part of the investigation of place making based on the preceding design informants.

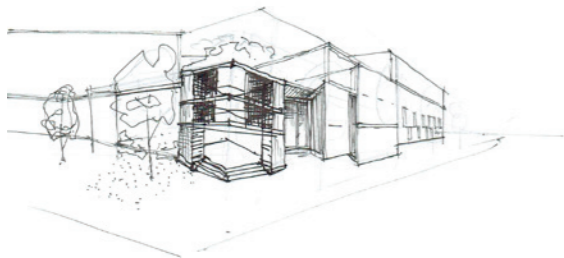

Fig. 192. Investigating the corner on the street.

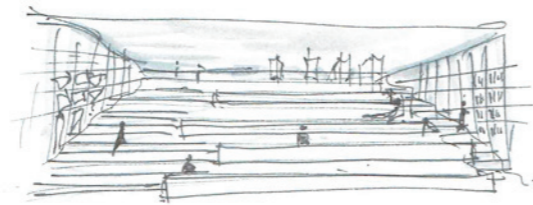

Fig. 191. Testing the manipulation of stairs into space.

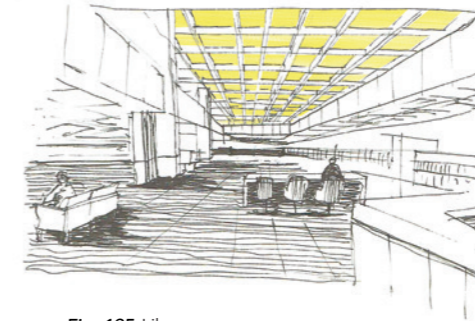

Fig. 195. Library spaces

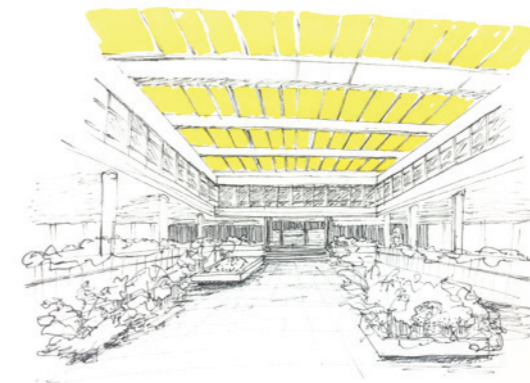

Fig. 194. A place to do nothing amongst light and plants

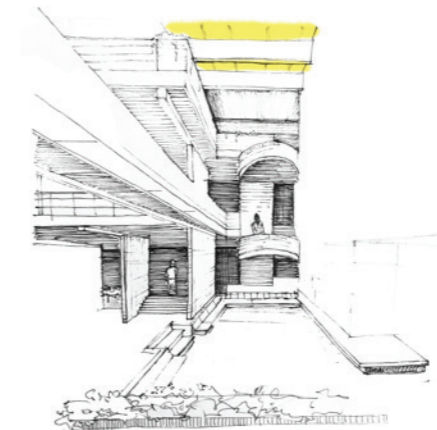

Fig. 193. Layering space in the library

*Views, light and thresholds*

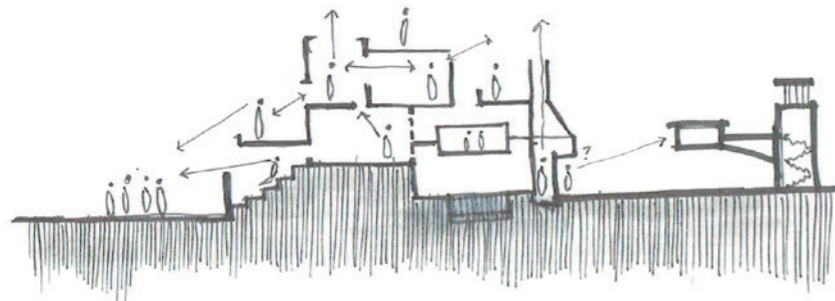

Fig. 196. The exploration of relationships in volume.

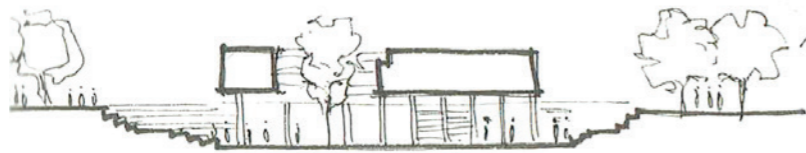

Fig. 197. A recessed realm.

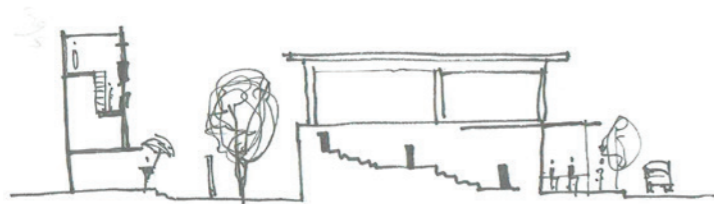

Fig. 198. Thresholds.

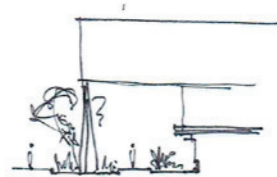

Fig. 199. Heavy shelter.

*Volumetric exploration*

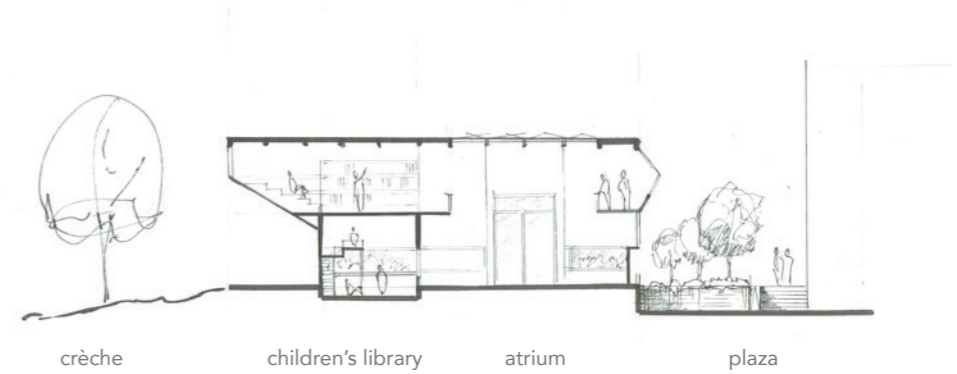

Fig. 200. Volumetric exploration of library spaces and thresholds.

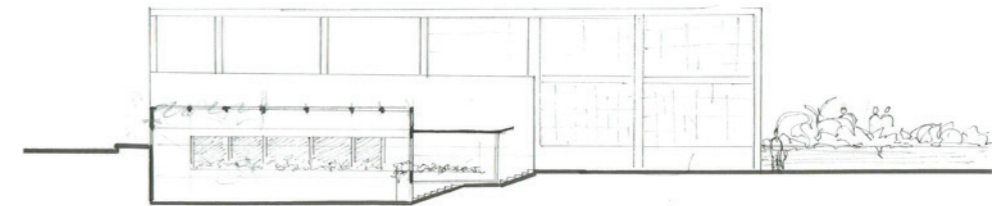

Fig. 201. Volumetric exploration of lower library offering quiet refuge.

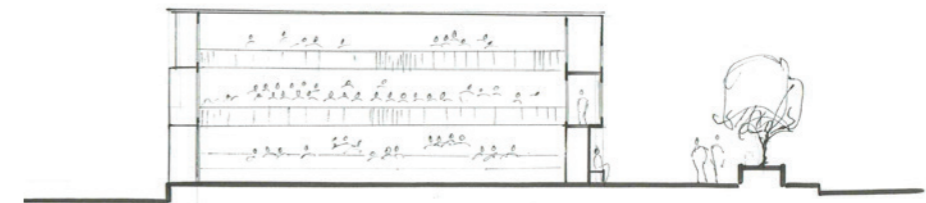

Fig. 202. Volumetric exploration theatre auditorium scale in relation to street edge.

"A great building must, in my opinion, begin with the unmeasurable, must go through the measurable in the process of the design, but must again in the end be unmeasurable. The design, the making of things, is a measurable act.

[...]

What is unmeasurable is the psychic spirit. The psyche is expressed by feeling, and also by thought, and I believe it will always remain unmeasurable.

[...]

To accomplish a building you must start in the unmeasurable and go through the measurable. It is the only way you can build, the only way you can bring the building into being - it is through the measurable. You must follow the laws, but in the end, when the building becomes part of the living, it must evoke unmeasurable qualities. The design phase involving quantities of brick, methods of construction and engineering is over, and the spirit of the buildings existences takes over."

Louis Kahn (1930:11)

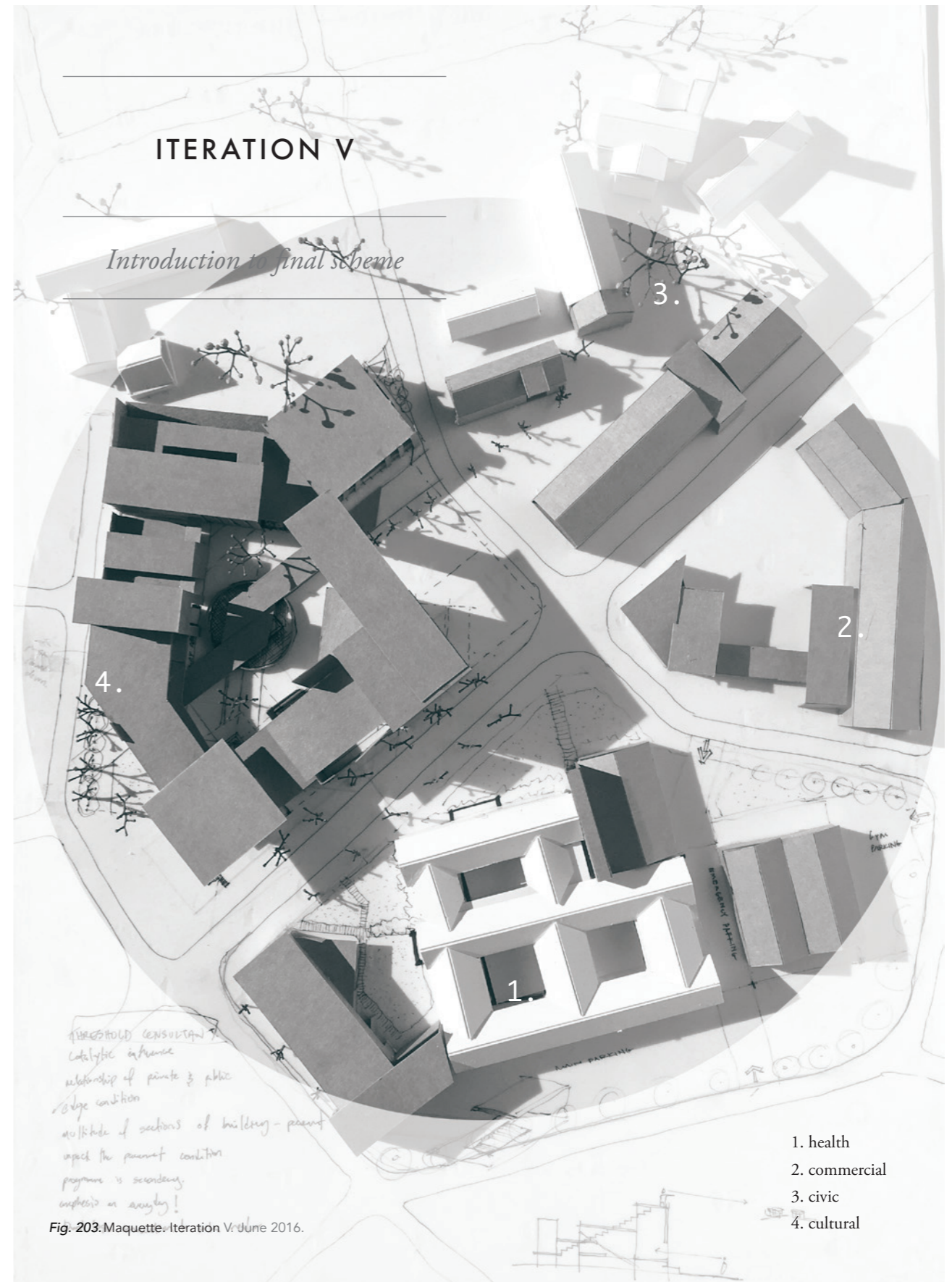

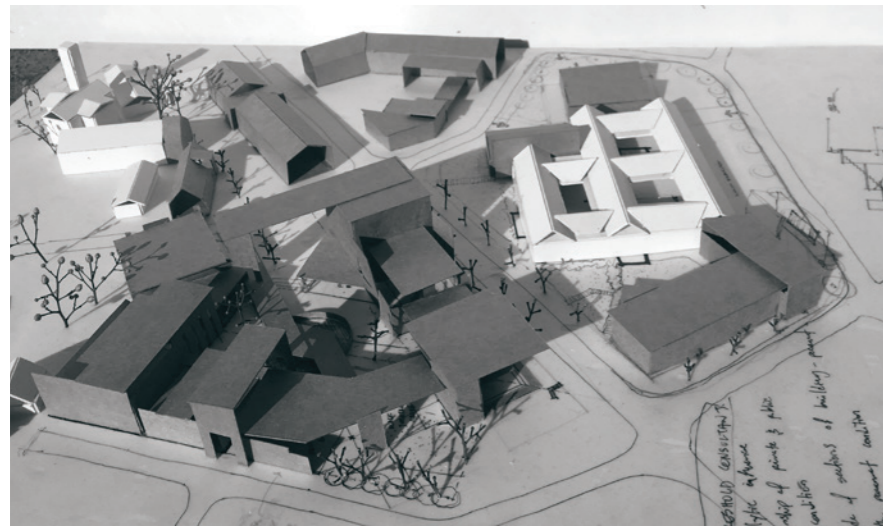

*Defining a new complex.*

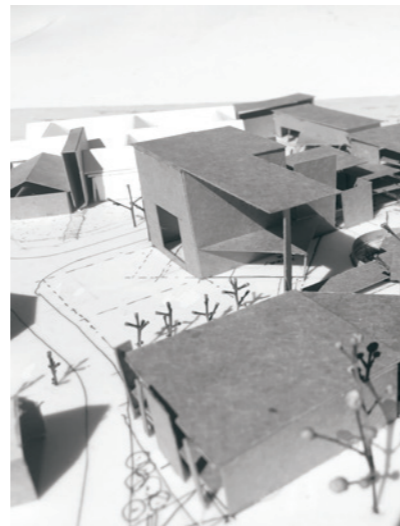

*Layering space.*

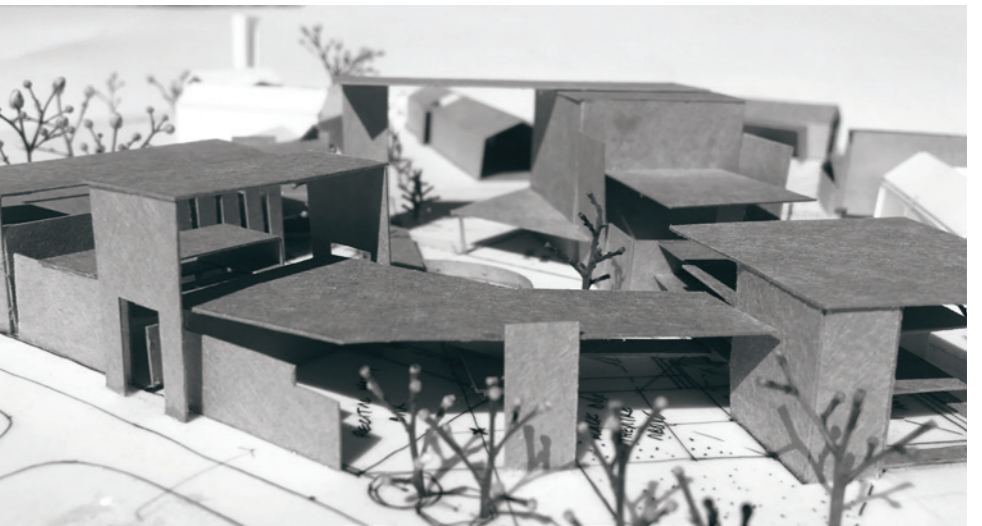
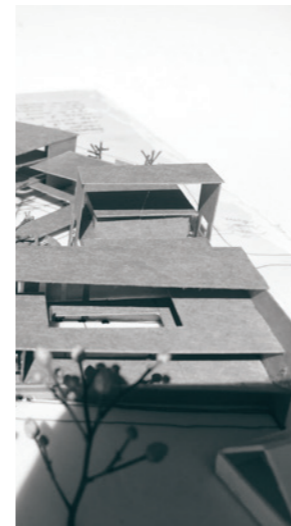

*Articulation of scale.*

*Fig. 204.* Defining a new complex (June)  
*Fig. 205.* Layering space (June)  
*Fig. 206.* Articulation of scale (June).

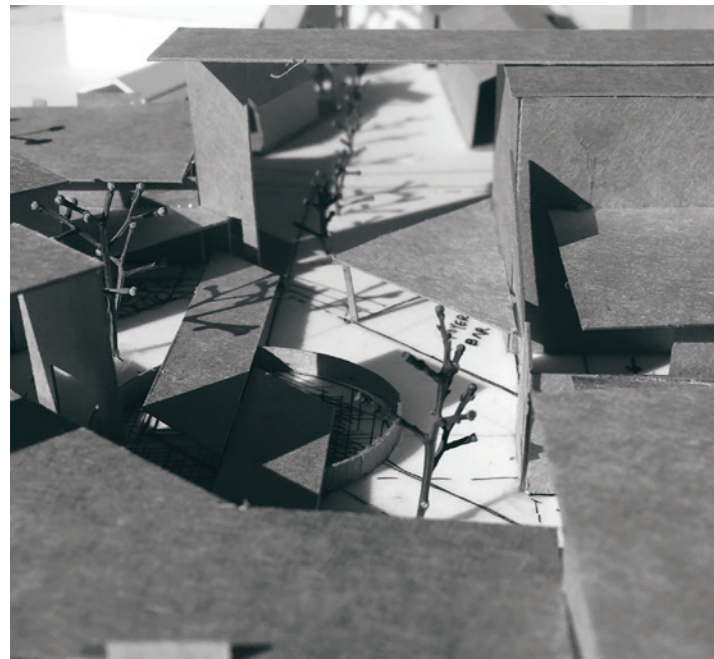

*Definition of public avenues.*

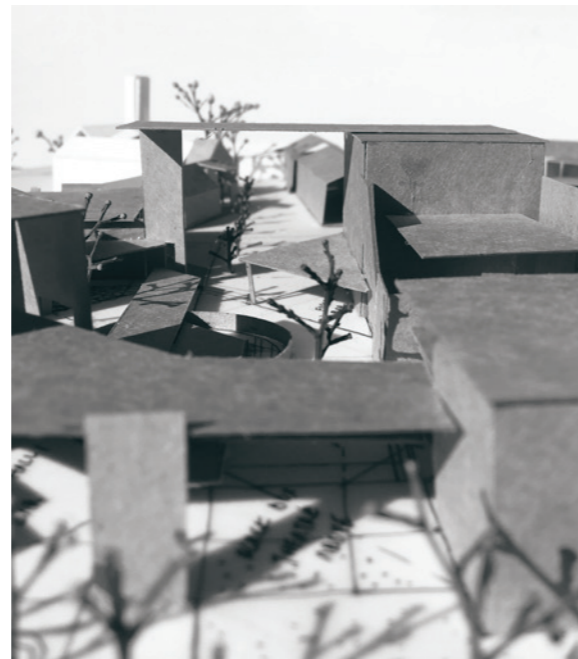

*Defining an entrance.*

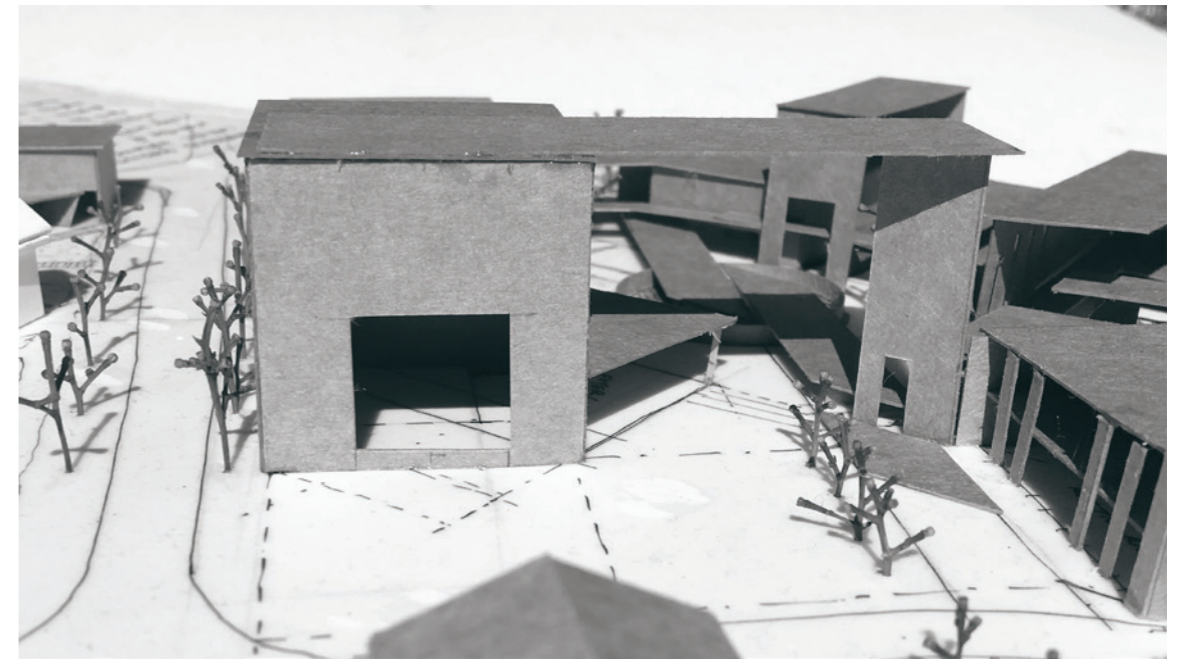
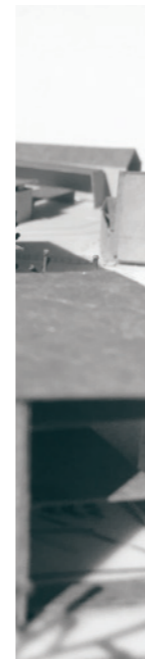

*Legibility of the public entrance.*

*Fig. 207.* Definition of public avenues (June)  
*Fig. 208.* Definition of public avenues (June)  
*Fig. 209.* Legibility of public entrance (June).





*Prominence of social anchors.*

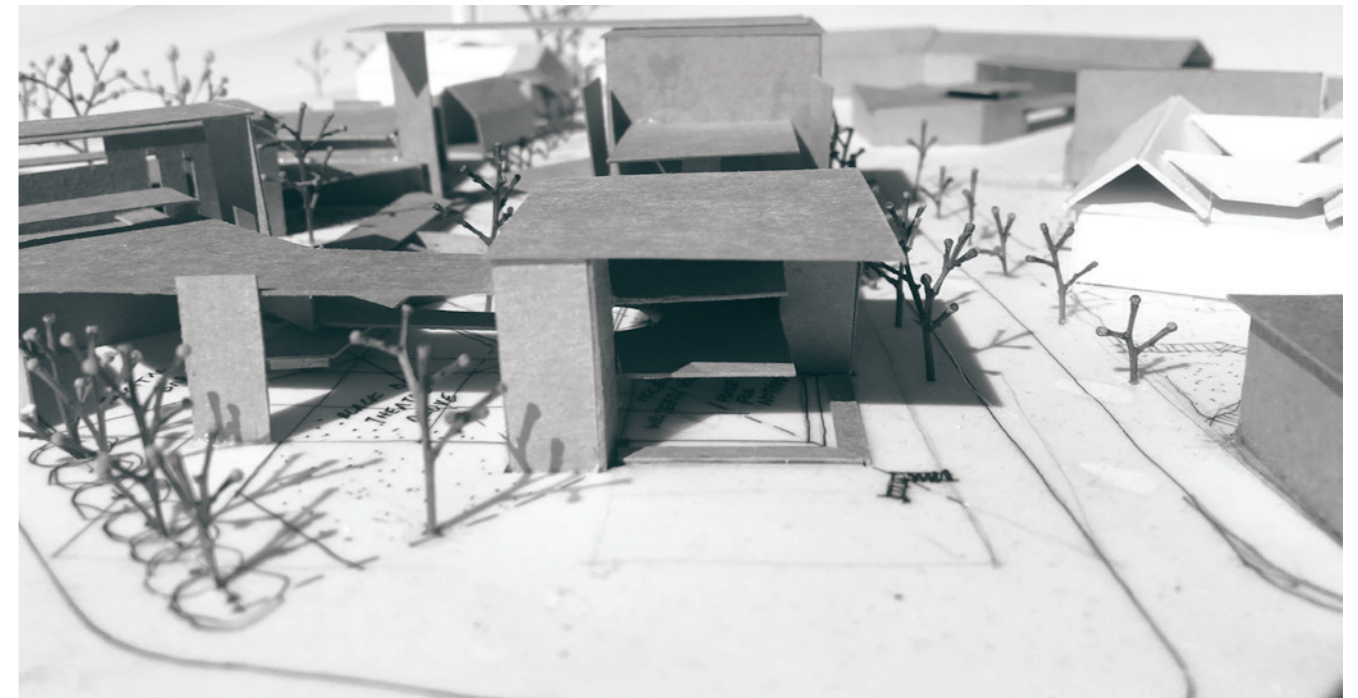

*Cutting the corner.*

## CONFIGURATION

### *Lessons from model building*

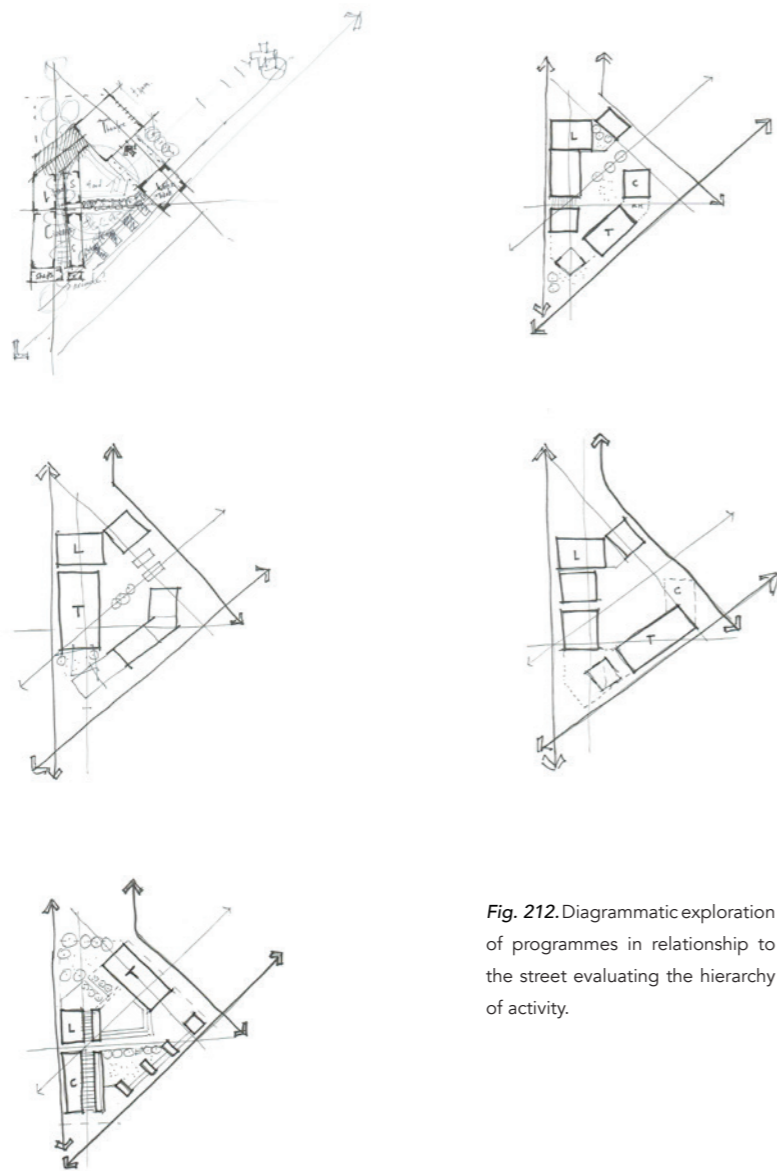

**Fig. 212.** Diagrammatic exploration of programmes in relationship to the street evaluating the hierarchy of activity.

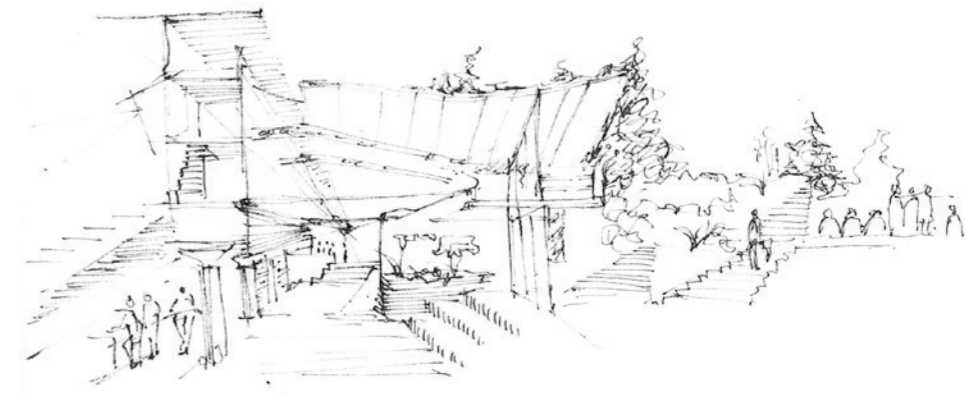

**Fig. 213.** Inducing slowness.

The preceding maquette exploration demonstrates the value of civic anchors in a suburban context. The public square provides refuge from the busy street. Connections are created across sites, tied together by a new surface - inviting a new *pattern of events* to occur.

The configurations explored in the diagrams on the opposite page test the value of a protected public square, responding to the programme requirements and the street edge. The street edge is defined, clearly indicating a change of pace as one enters the site.

This *slowness* experienced upon entering the campus allows the user to be truly present, attuned to the spirit of the collective. The new heart of Atteridgeville offers visitors a place to *get lost*; within pockets of familiarity, unexpected aural and visual stimuli prompt reverie, enabling the site to become a repository of dreams and memories.

The following pages develop the maquette formally through the use of plans and sections in an attempt to develop a spatial expression of the conceptual intentions.



The plan above demonstrates the investigation of a new urban-courtyard typology. The pattern imposed onto the site is exposed in the surface treatment of the ground plane, creating routes which traverse boundaries and connect experiences. These connections are enhanced by providing space for nature, highlighting our connection to the rhythms of the natural world. A variety of entrances is provided, each preparing the user to slow down upon entering the space.

Fig. 214. Ground Floor Plan. Iteration V (June).

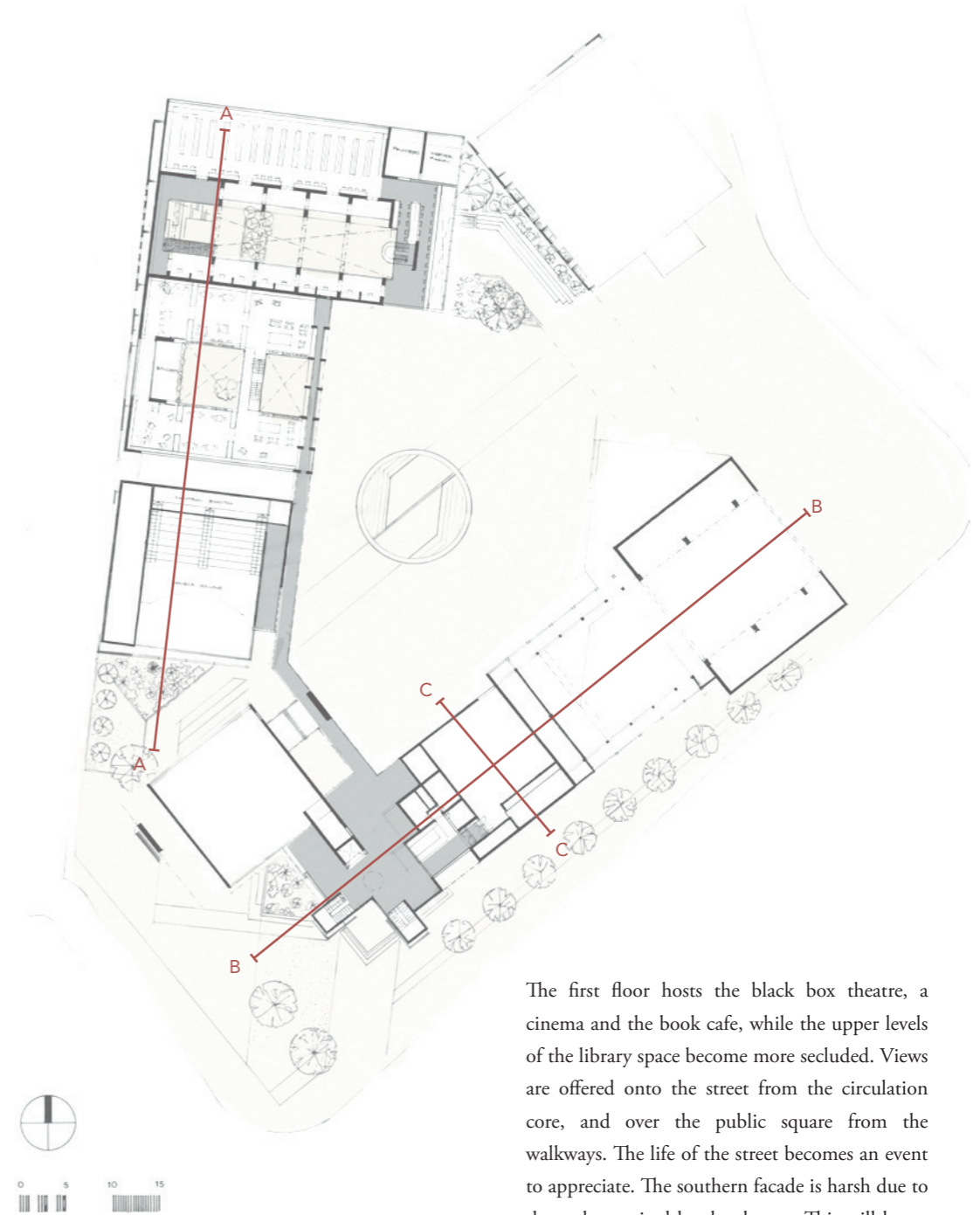

The first floor hosts the black box theatre, a cinema and the book cafe, while the upper levels of the library space become more secluded. Views are offered onto the street from the circulation core, and over the public square from the walkways. The life of the street becomes an event to appreciate. The southern facade is harsh due to the scale required by the theatre. This will be an important aspect to consider and refine.

Fig. 215. First Floor Plan. Iteration V (June).

LIBRARY

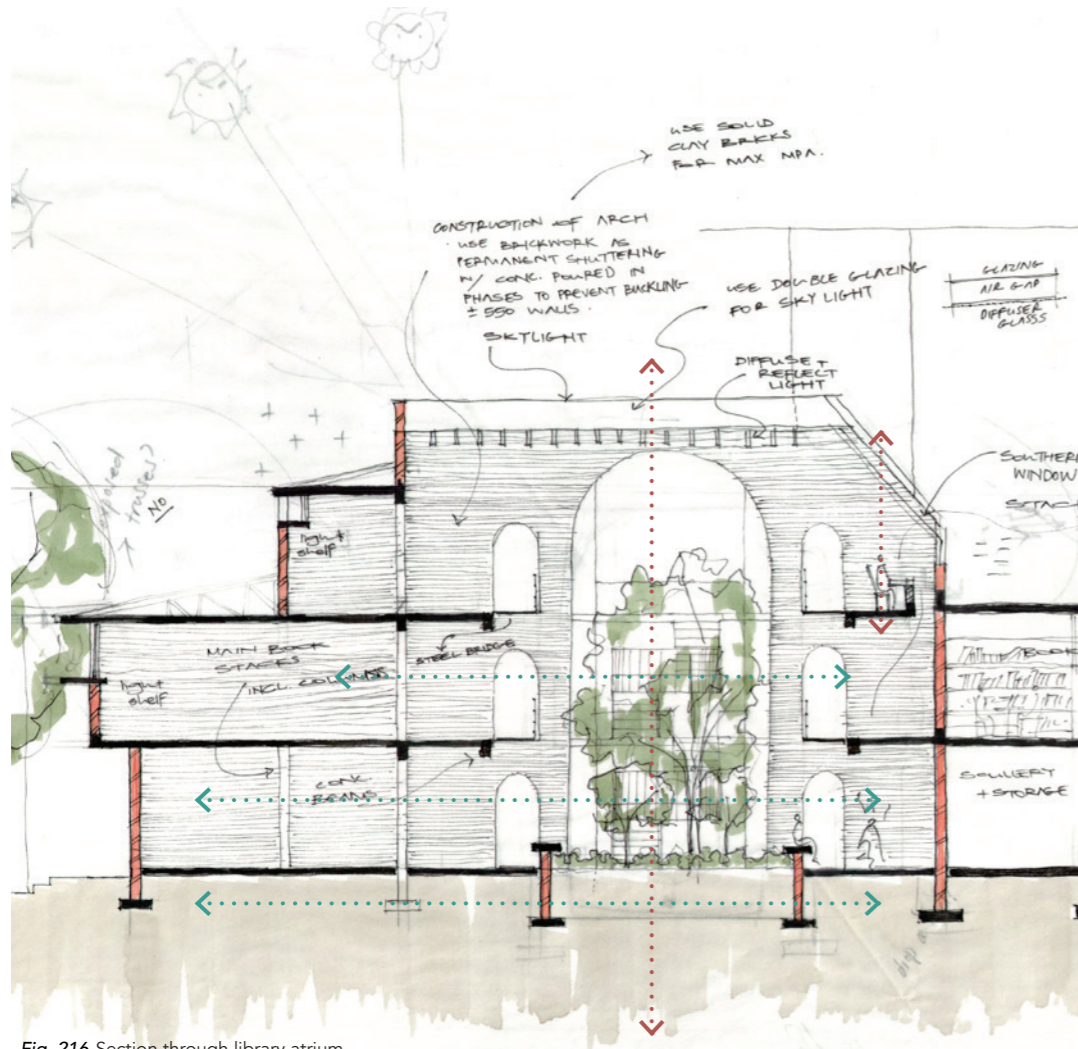

Fig. 216. Section through library atrium.

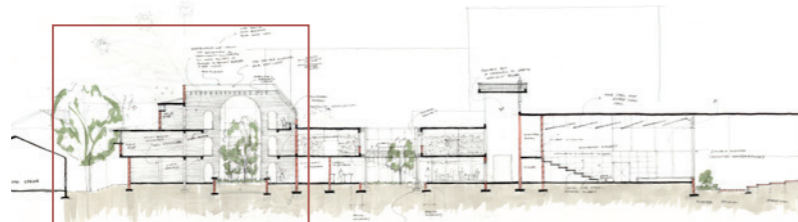

Fig. 217. North-south section from library to blackbox theatre (July).

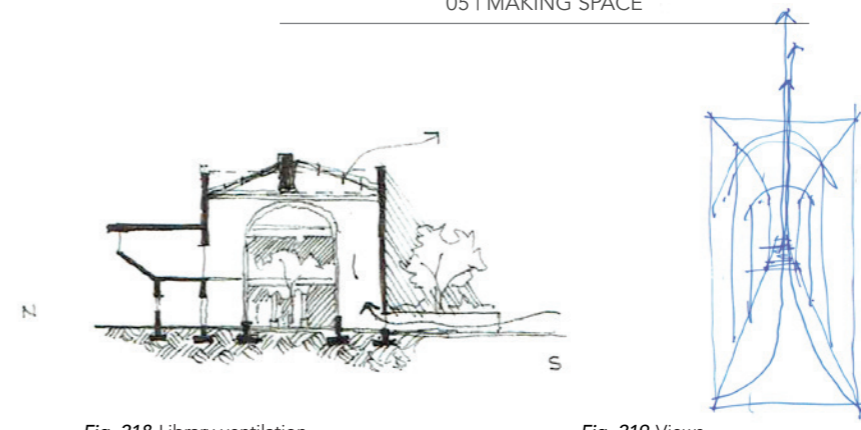

Fig. 218. Library ventilation

Fig. 219. Views.

These images demonstrate the investigation of the library volume. The intention is to create an open, well-lit volume with a large atrium enhancing the height of the space and the connection to the sky. Views across the atrium connect users to one another and focus the experience on the tactile qualities of the space. The stereotomic mass of the masonry construction is contrasted by the emphasis on the verticality. This exploration considers skylights spanned between each arched wing (approximately five metres across). Solar heat gain is a serious concern in this regard, so double-glazing with a substantial air gap is considered, with baffled panels below to reflect and diffuse light.

Initially a concrete structure was considered. This would have resulted in a heavy, wasteful structure, and not achieve the desired aesthetic. An alternative option would be to use brickwork as permanent form-work, and the concrete would be cast in phases to prevent buckling.

The concrete floors on each level become lighter towards the atrium and de-materialise as bridges are suspended between the brick work, almost floating between openings. This reinforces the lightness and verticality of the atrium space.

To control thermal comfort, cool air is brought into the building by taking advantage of the constant temperature below ground (18°C at 600mm below ground level) using earth tubes. Openings on the northern facade will allow air to enter from the predominant direction for cross ventilation. Heated air will collect at the highest point, with controlled extraction. The thermal mass of the masonry and concrete allow for the flywheel effect. Heat will be retained in the structure and night flushing will rid the building of heat in summer, or it could be utilised in winter months. Finally, the use of a planted atrium will also aid in the thermal comfort and contribute to the overall experience.

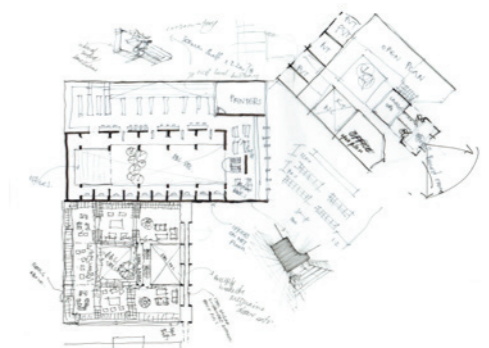

Fig. 220. First floor plan of library and restaurant.

## FOOD + BOOKS

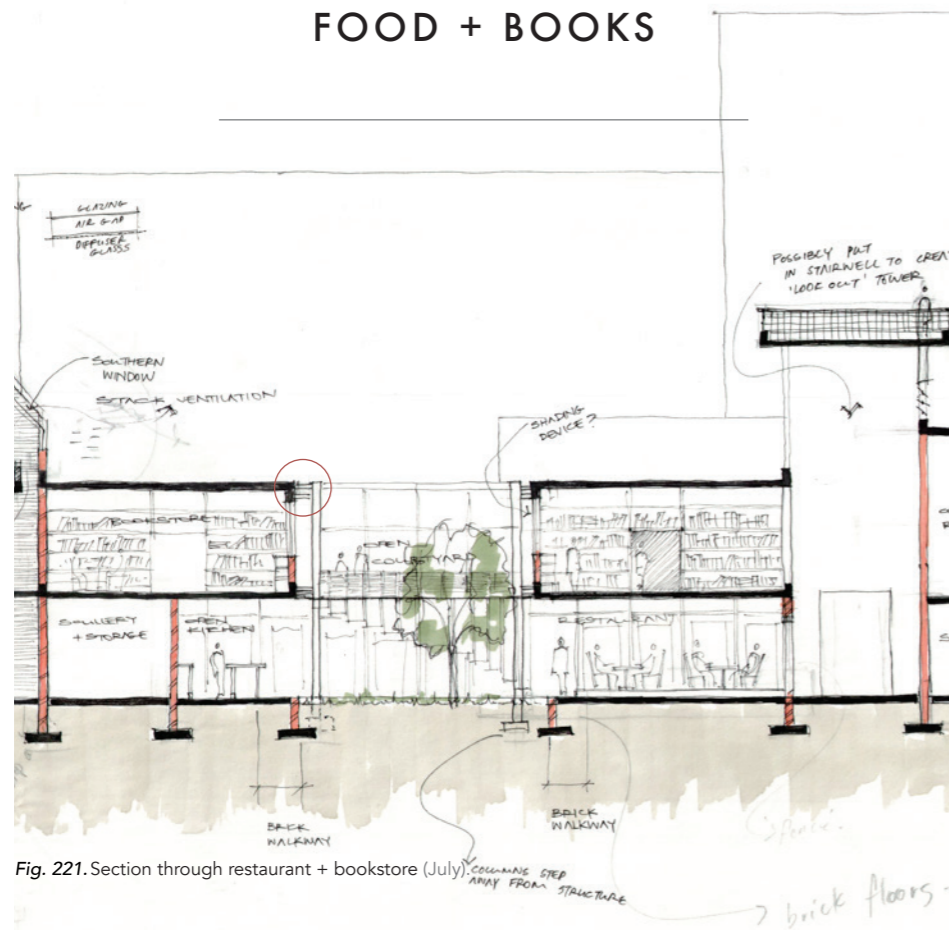
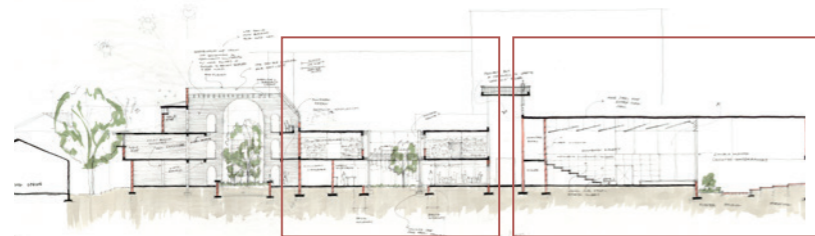

Fig. 221. Section through restaurant + bookstore (July)

The restaurant is hosted at ground level, allowing for a direct connection to the public interface on the east. An open courtyard allows for an outdoor space, more intimate than the larger square. Similar to the library, as one gets closer to the central courtyard space, the heaviness of the brickwork lightens through the use of concrete

columns, and this junction is highlighted. The courtyard allows for stack ventilation to occur on both levels.

The bookshop is elevated from the street level providing quiet spaces with a view over the square.



## RECITAL HALL

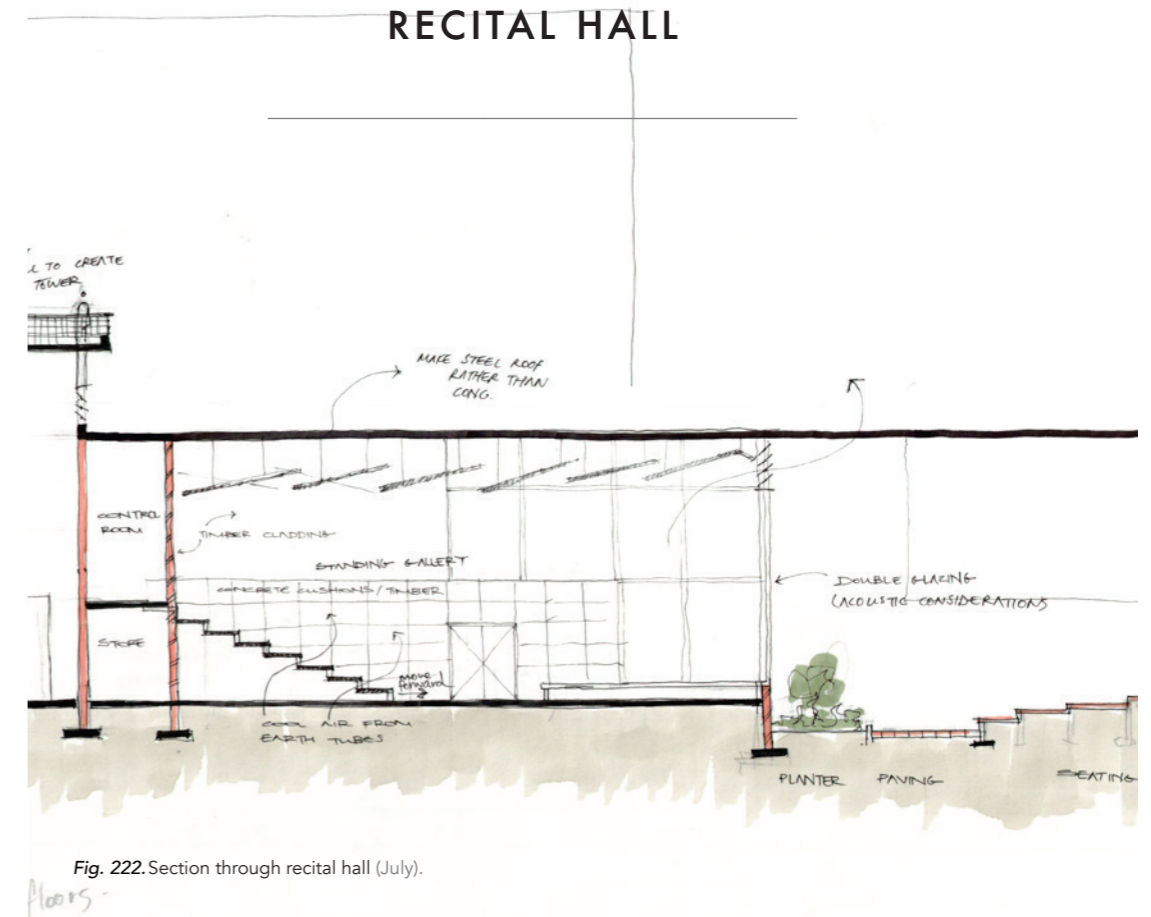

Fig. 222. Section through recital hall (July)

The recital hall is a simple, rectangular space that opens into a courtyard. It is vital that the box is acoustically sound so that outside noise does not interfere with a private performance. The walls should increase to at least a 330mm cavity wall, aided by the variety of adjustable acoustic panels. Since a visual connection is desired, glazing is proposed on the southern facade. This would require at least two 6mm laminated glass planes

separated by a 150mm cavity with absorptive panels within the frame.

Side walls will host reflective acoustic panels while the back of the hall should be absorptive. The central aisle of overhead acoustic panels should be reflective and the outside, absorptive.

## ENTRANCE

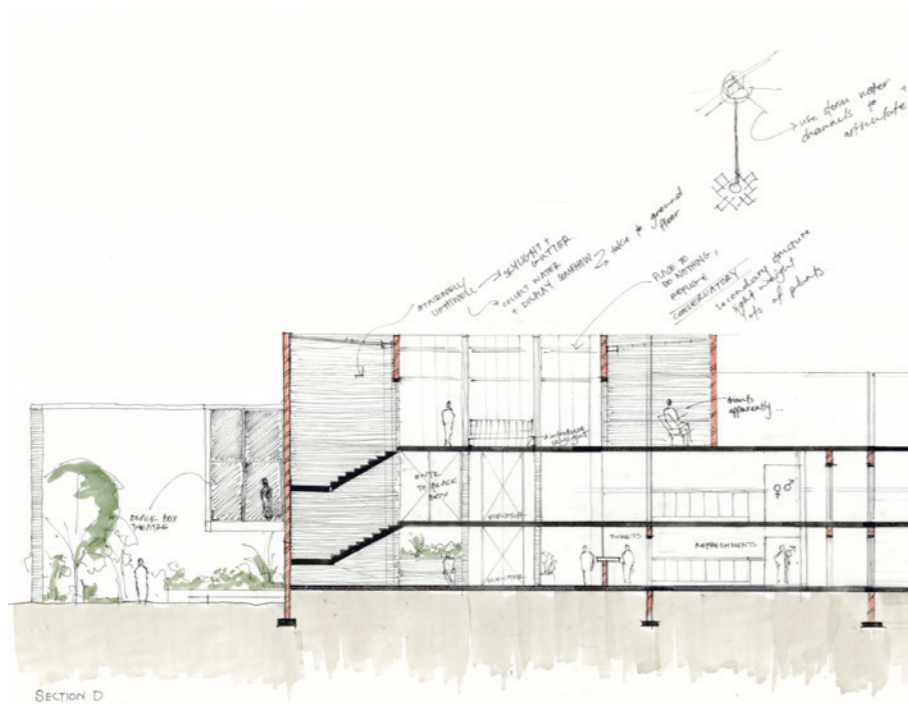

Fig. 224. Section through entrance and cinema service space (July).

The entrance on the south western corner (Mareka street) announces a pedestrian point of access. This space functions as the main vertical circulation core, again highlighting the stereotomic qualities of the masonry but using these points as lights wells, allowing the sunlight to wash down the textured walls. This space combines the very open public foyer with

a very public, yet contained cinema and then the writers refuge above. The design achieves the same principles of diverting attention to the sky through the use of skylights.

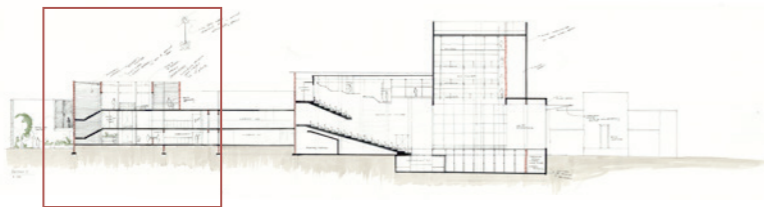

Fig. 223. Section BB. Iteration V (July).

## CINEMA

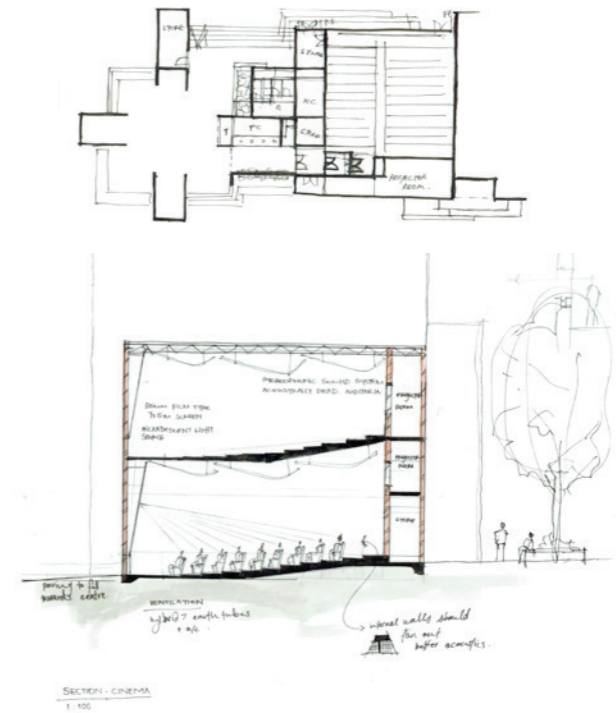

Fig. 225. Plan and section through cinema (July).

The cinema requirements include a stereophonic sound system in an acoustically dead auditorium with zero reverberation. The side walls should not be parallel, which will be catered for using acoustic panelling. Thicker walls are necessary for sound isolation, rather than cavity walls. Also, corner echoes are a concern, and will be resolved through the use of an appropriate material, for example carpeting.

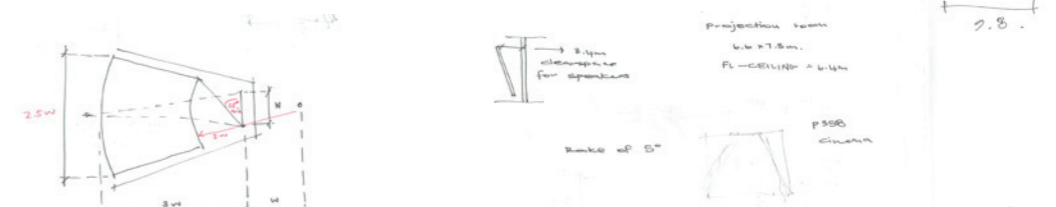

Fig. 226. Cinema requirements.

# THEATRE

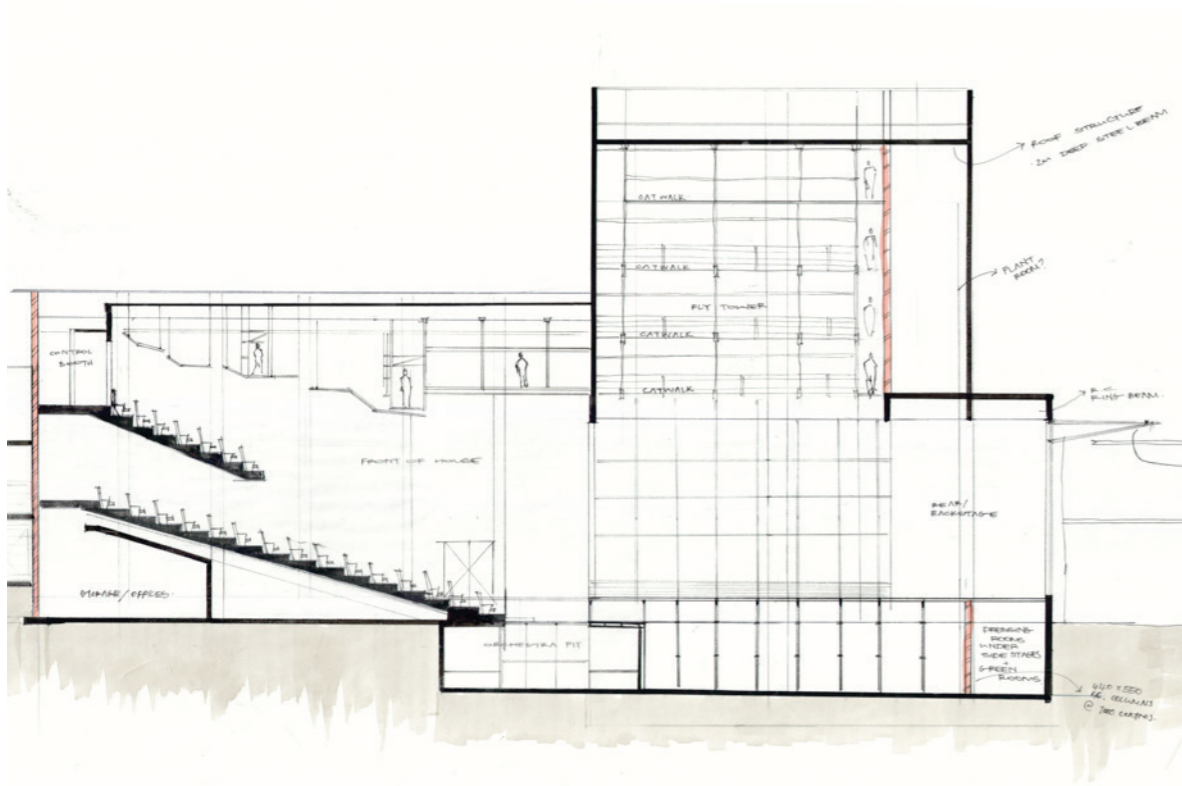
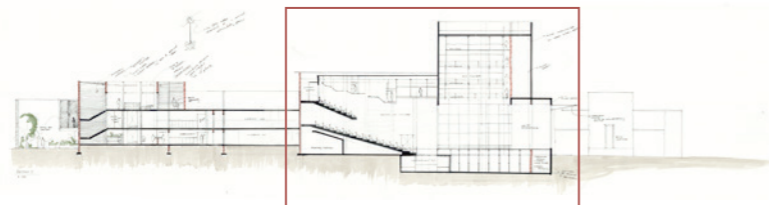

Fig. 227. Section through theatre (July).



Section BB. Iteration V (July).

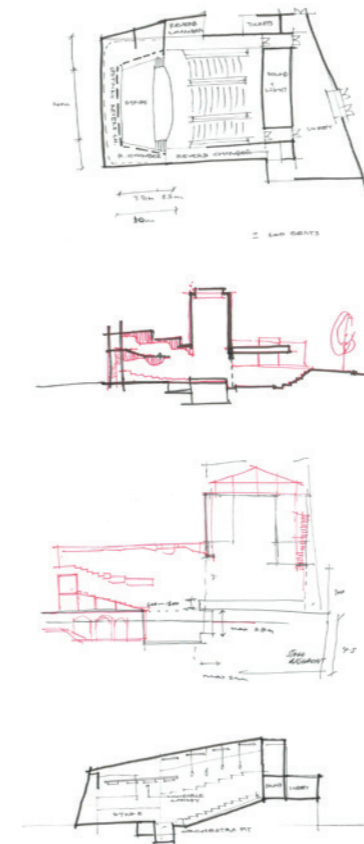

Fig. 228. Exploration of theatre configurations and basic requirements.

Theatres of this scale require substantial facilities to ensure traveling performances can use the space adequately. One of the main requirements for a versatile theatre which could accommodate opera, music, dance and drama, is the stage size and proscenium opening. This needs to be supported by a flytower of at least 2.5 times the height of the opening. The proscenium opening is 7 x 13m, with a stage of 7 x 14m, flanked by two side stages and a small rear stage.

Various configurations were considered with regard to the stage position. It was decided that the stage should open into the public square, thus a closed back stage was not an option. These spaces have been moved into the basement level, flanking the traproom. The massive flytower requires a large superstructure that allows for maximum freedom to avoid interruptions on the stage. A concrete structure has been chosen, using ring beams to carry the walls with tie beams in between.

330mm cavity walls have been considered with solid timber doors at the sound lobbies. The acoustic considerations will utilise the absorptive qualities of the face brick walls in conjunction with acoustic panels. The underside of the raked seating will be treated to absorb sound.

Thermally, a hybrid system has been considered to reduce the load and reliance on mechanical systems. This is dealt with later in the document.

## PERSPECTIVES



Fig. 229. View of black box theatre and entrance.

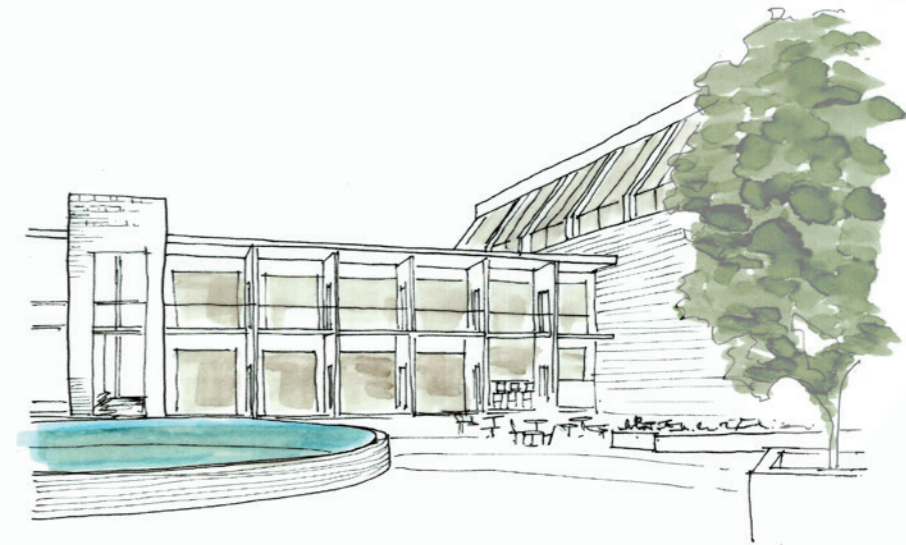

Fig. 233. View of the square and restaurant.



Fig. 230. View of towards the library.



Fig. 231. The arcade.

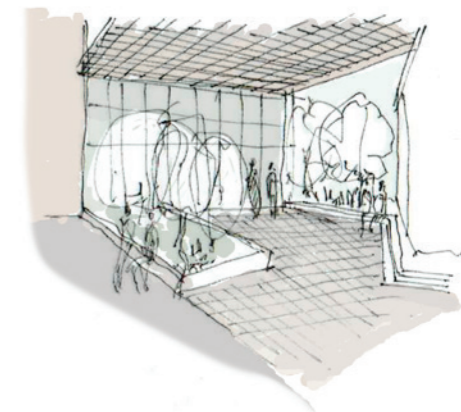

Fig. 232. Library entrance.





## THE STREET

### *Designing elevation*

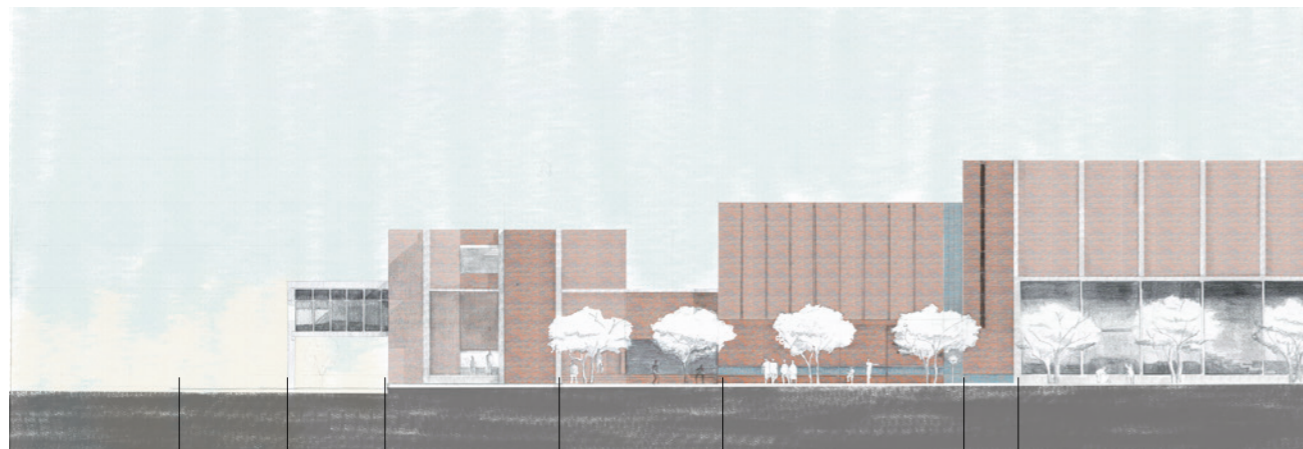

sidewalk Masibi street	blackbox theatre	entrance vertical circulation writer's refuge	services and bus stop	movie theatre	theatre auditorium external circulation	theatre stage flytower (recessed)	public stage	plaza Maboea st.
---------------------------	---------------------	-----------------------------------------------------	--------------------------	---------------	--------------------------------------------	--------------------------------------	--------------	---------------------

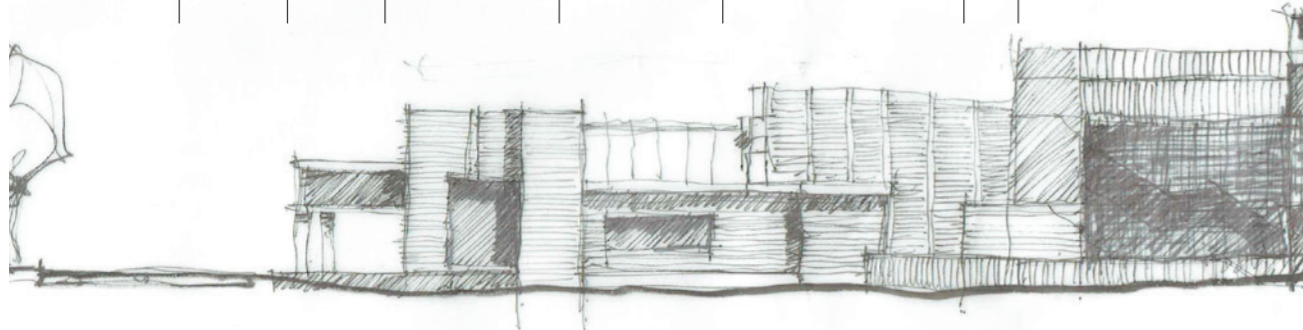
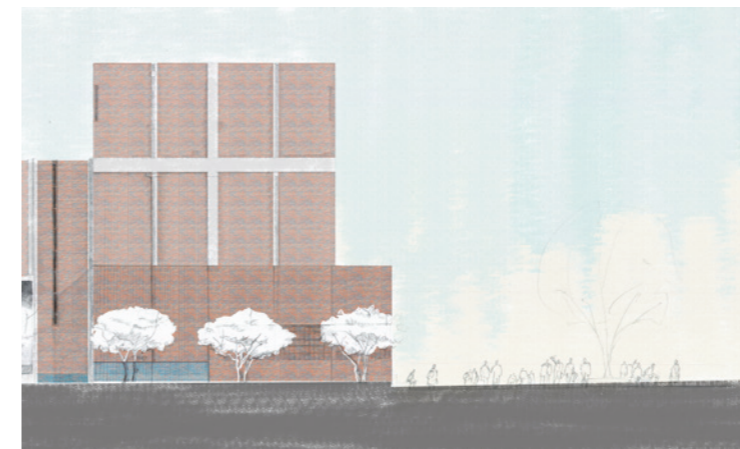
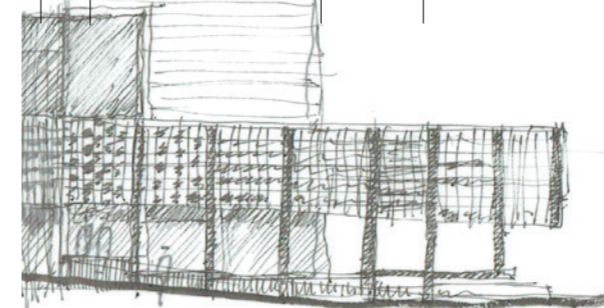

Fig. 236. Mareka street elevation. Iteration V (Jul).

Fig. 237. Mareka street elevation (Oct).



theatre stage flytower (recessed)	public stage	plaza Maboea st.
--------------------------------------	--------------	---------------------



The southern facade on Mareka street hosts the most selfish programmes: the theatre and cinema. Both programmes require large volumes and solid exteriors due to the 'black box' nature of the activity within.

To address this issue, the modularity and human scale of the brick module was exploited. The articulation of the facade reduces the perceived scale. Stepping back of larger portions, the flytower especially, ensures one is not confronted by the tower whilst walking beside the building. The circulation of the theatre auditorium is exposed on the south to create a visual connection between the passer-by and audience member for a moment.

Trees are proposed to line this avenue, bringing down the scale and contributing to the experience and combat the heat island effect. Ceramic tiles or glazed bricks are introduced to break the vast wall of brickwork, introducing colour and reminders of internal conditions. The movement of water from the roof to the street level is highlighted to begin the relationship with water across the site.

Despite these considerations, the structure appeared too heavy. The second elevation explores breaking-up the structure further through the introduction of a pergola structure. The bus stop is enlarged the bus stop to accentuate pause spaces along a route. This iteration is unsuccessful and will be explored further.



**CARLO SCARPA**  
BRION CEMETERY,  
SAN VITO D'ALTIIVOLE,  
TREVISO, ITALY

Fig. 238. Brion Tomb, 2013.

“Layering exists in a realm of complexity and implies a capacity of being interpreted that goes beyond itself and creates references to the world at large instead of narcissistically contemplating itself alone. A building becomes a cumulative composition made up of elements of varying materials and provenance. In contrast to the architectural monolith, which demonstrates a sheer three-dimensional volume made from one material and negates the »hollowness« of architecture that is implied by its function, layered architecture celebrates the parts and the process of its genesis. Instead of the compositional unity of a monolith, layering features a compositional balance of elements.”  
(Schultz 2014:6)

1978



Fig. 239. Carlo Scarpa's Brion Tomb, 2013.

**AUTHOR'S NOTES**

I have been fascinated by Scarpa's architecture from the moment I saw a photograph of the water feature at the Brion Tomb (Figure 238). I then lost myself in Scarpa's world of intricate detailing. Although I still find it impossible to comprehend his work, despite numerous visits to his projects, I continue to be inspired by the art of putting things together. The layering, material palette, complexity and magnificent composition allows me to get lost and feel connected at the same time. There is a familiarity in his work.

The intention is to learn from this master and devise similar techniques to create connections across the site and create the same magic Scarpa seems to so effortlessly create.



1958  
CARLO SCARPA  
OLIVETTI SHOWROOM, VENEZIA, ITALY

Fig. 240. Carlo Scarpa's Olivetti showroom, Venice, 2013 (all images on spread).



Drawing inspiration from the elegant execution of detailing by Carlo Scarpa, the design of surfaces and connection will form an integral part of the technical exploration of this scheme.

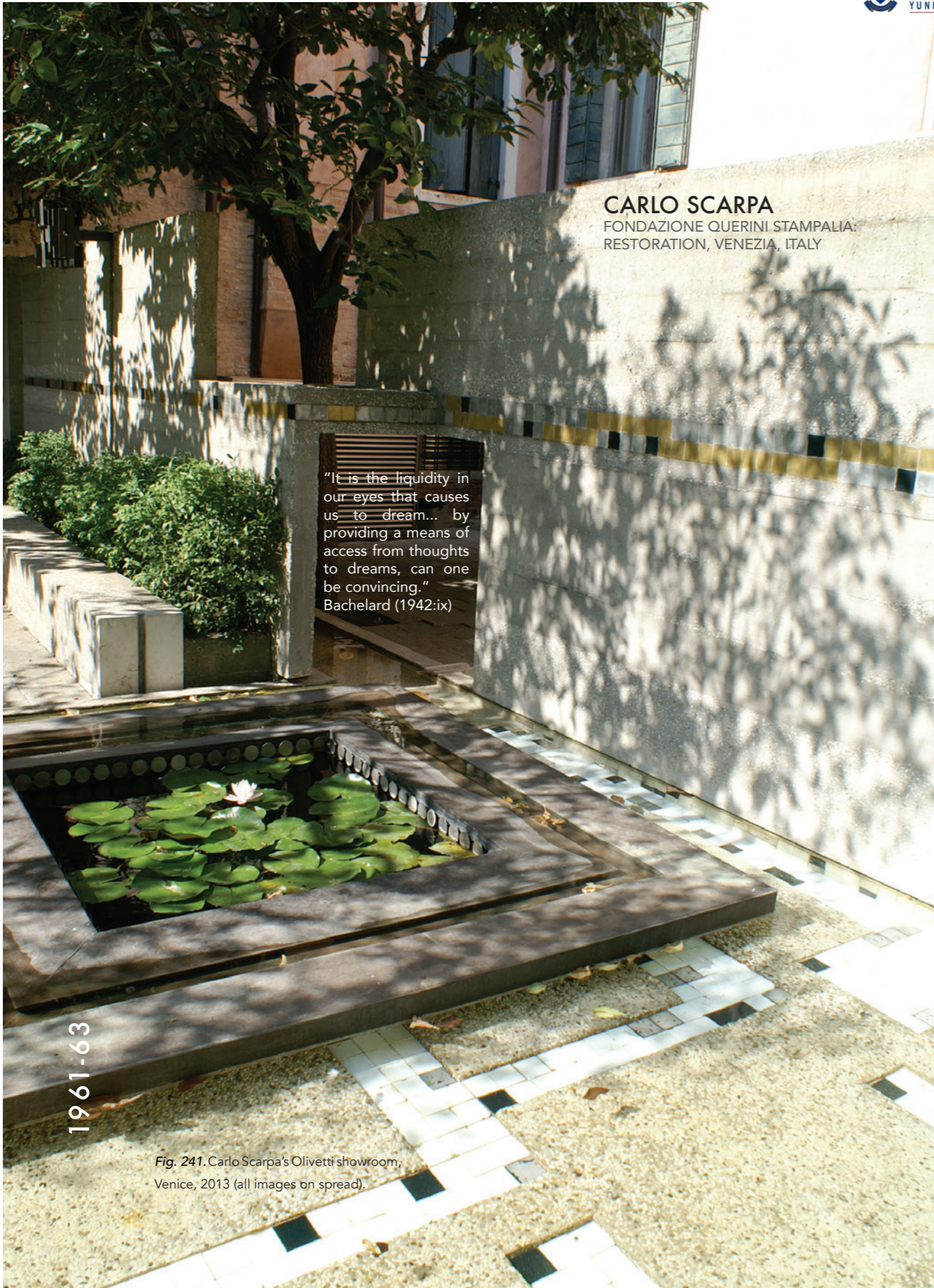

**CARLO SCARPA**  
FONDAZIONE QUERINI STAMPALIA:  
RESTORATION, VENEZIA, ITALY

"It is the liquidity in our eyes that causes us to dream... by providing a means of access from thoughts to dreams, can one be convincing."  
Bachelard (1942:ix)

1961-63

Fig. 241. Carlo Scarpa's Olivetti showroom, Venice, 2013 (all images on spread).



There is a desire to create a relationship between memory and dreams throughout the scheme. This will be explored through the use of water and routes to invent new links across the site.





Fig. 242. View of the library from the garden, Wright & Wright.

## WRIGHT & WRIGHT, 2020

LAMBETH PALACE LIBRARY EXTENSION

Wright & Wright's proposal for the first new addition to Lambeth palace, one of the United Kingdom's oldest libraries. The historic home of the Archbishop of Canterbury, the Lambeth Palace Library has had a publicly accessible collection since 1610. This library is the main archive for the Church of England and is the second-largest collection of religious texts in central Europe after the Vatican (Winston 2016).

The project is described as "an occupied wall" with an eight-storey tower at its centre." The red clay brick structure pays homage to the surrounding Palace buildings which forms a screen enclosing a pond, and protects the garden from pollution and traffic noise. The top of the tower offers views towards the Palace of Westminster while the main public reading room faces outwards towards the palace's gardens. Large areas of glazing allow for maximum natural light (Winston 2016).



Fig. 243. Views of the library from the street, Wright & Wright.



Fig. 245.  
Library.



Fig. 244.  
Library.

## AUTHOR'S NOTES

Wright & Wright's design displays a sensitivity to context despite the large scale required for the library addition. The use of face brick creates a monolithic structure but the articulation of the surface through the manipulation of brick courses breaks the facade into smaller portions. The lighter elements hosted at the top of the eight-story tower allows the structure to de-materialise as your eye follows it skyward, creating a beacon of light.

The architects argue that libraries will continue to be valuable spaces in cities despite the rapid pace at which technology develops. They describe libraries as the new 'cathedrals' of the city (Winston 2016). It is a reminder that cities and spaces for the everyday city-dweller should remain a priority.

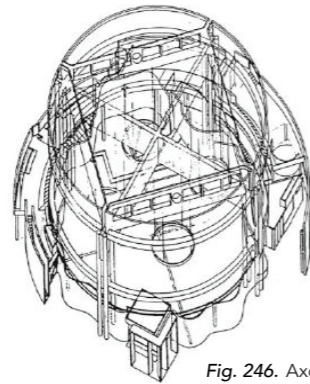

Fig. 246. Axo of the church.

## KAMMEYER, ROZENDAL, CARTER-BROWN

THE CATHEDRAL OF THE HOLY NATIVITY, PIETERMARITZBURG, SOUTH AFRICA

The national competition for the design of the Cathedral Church of the Holy Nativity in Pietermaritzburg was won by Heinrich Kammejer and Norbert Rozendal. The cathedral was required to bring together the High and Low Churches of St Peters and St Saviours. The design considered an entire cathedral complex including worship facilities and supporting programmes which were required to respond to the pedestrian walkway and the unbuilt shopping mall. It was vital for the cathedral to be integrated into the urban fabric and respect the existing architecture (Theron 2015: 50-2).

Considering the vast scale of a cathedral - a large, mostly empty space, it is given back to the people in the dense fabric of the city. The structural solution responds to the intention of creating a 'container' - a large brickwork 'drum' is carried on heavy concrete beams - a square inside a circle providing a unified, free volume below. "The geometric purity and simplicity of the drum, gives way to an increasing complexity as one moves towards the outside: a transition of space and symbol." (Theron 2015: 52).

Theron (2015:52-3) describes how the structure carrying the roof becomes part of a universal language. The cross makes reference to religious symbolism, but spatial orientation as well (the four cardinal points) while making reference to St Peters and the street. The architects not only acknowledge the spiritual connection, but also the Cathedral's connection to its human counterparts and context.

*Each time a person visits the Cathedral, they are made aware of the climate which is a part of a higher order. Light is used to emphasize the separation of elements. Windows are purely to modulate light, this modulation becomes an expression of the window itself: the aesthetic lies in the making. (Kammejer quoted by Theron 2015:53).*

Theron (2015:52-4) explains how Rozendal and Kammejer explored detailing to heighten the experience of visiting the Cathedral. The intention was to communicate the human scale through detailing and also making the various parts or forms of the Cathedral visually obvious. The structure was to be read as a complete experience rather than just a supporting element. To achieve this, the columns step away from the wall, and each subsequent layer is treated independently: the walls, beams and balustrades.

*A centre is created for the convergence of a diversity of values and influence (Theron 2015:55)*

The theme of hidden spaces or "spaces behind" is repeated throughout the Cathedral complex suggesting that there are hidden spaces revealed only through exploration. The roofscapes, walls, fenestration and structure hint of this. The garden and sky are revealed, suggesting an extension of the architecture. Even the building is revealed bit by bit.



Fig. 250. Courtyard.



Fig. 247. Stairway.  
Fig. 248. Thresholds.  
Fig. 249. Rhythm.

All photos by Theron & Kammejer. 2015



## AUTHOR'S NOTES

Theron exposes the sensitivity and control adopted when responding to a highly symbolic and spiritual programme. The cathedral's requirements with regard to scale were achieved by manipulating materials, structure and light to ensure a human scale, in a super human-scale structure. The result: awe-inspiring volumes making reference to the spiritual and physical world. The cathedral does not function as an isolated object in space, but makes a contribution to the community through well designed intermediary spaces. When considering public spaces and public buildings, which are vital in our developing cities, this Cathedral offers many valuable lessons.