

# 6 TECHNOLOGICAL DEVELOPMENT

iterations & analysis

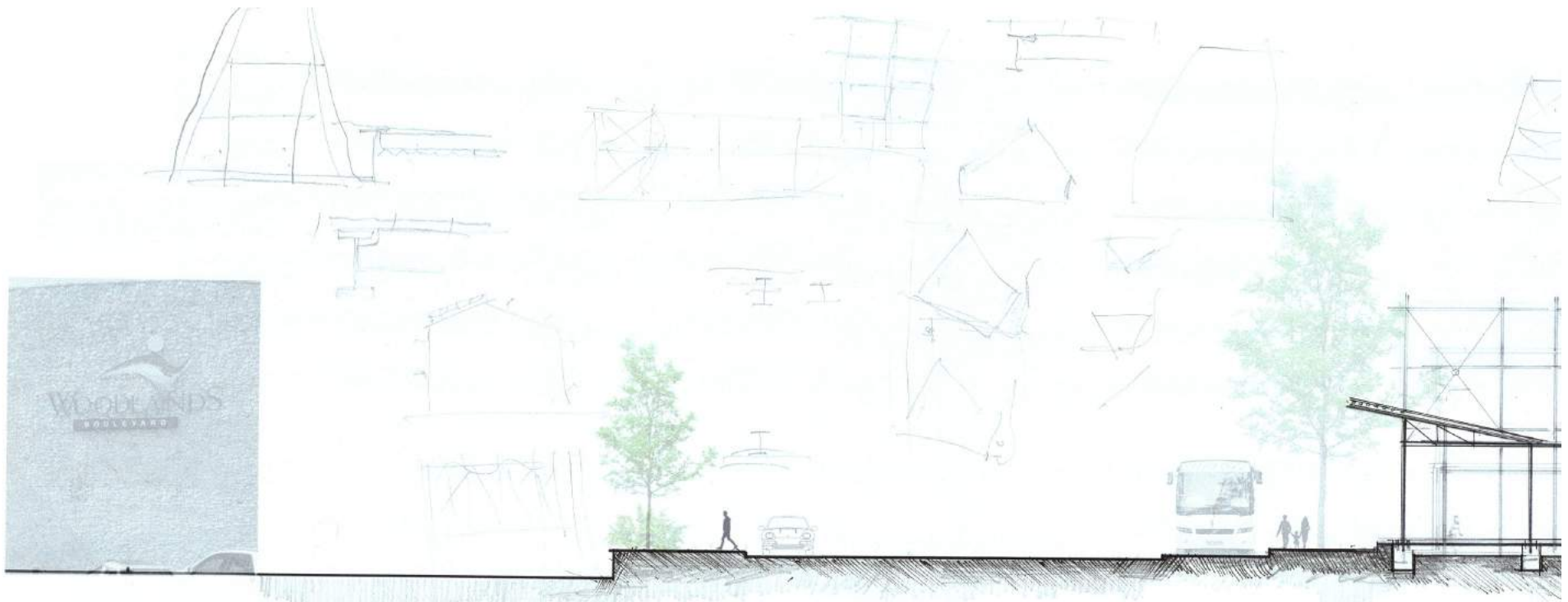



SECTION AA

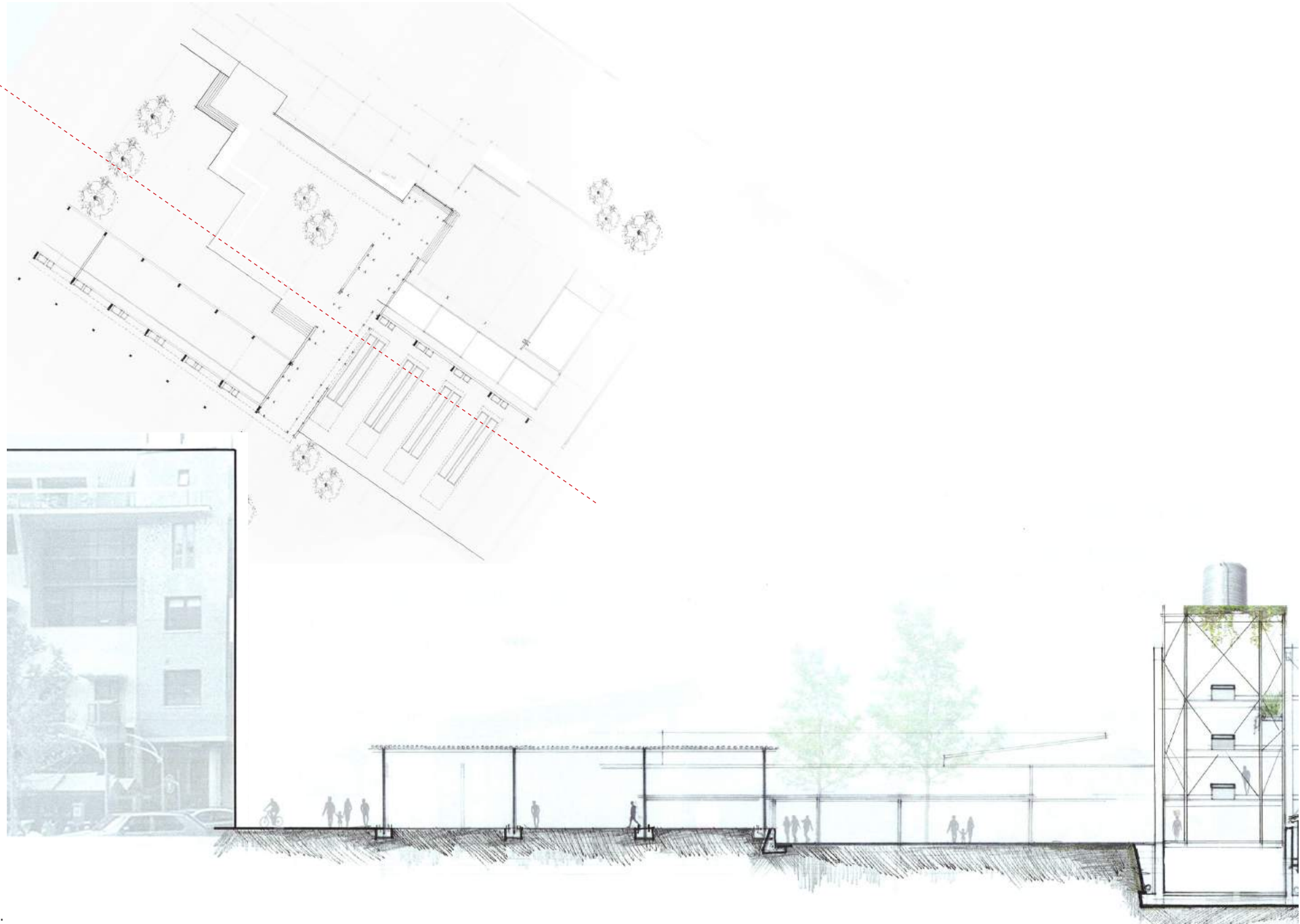

## june critique

---

Sections are still very diagrammatic and require a better understanding.

Materiality is lacking and needs to be represented within the sections clearly.

More context is required.

The design is about social interactions and this needs to be represented throughout the section.

Consider section choice and make sure it displays the conceptual and design intention.

---

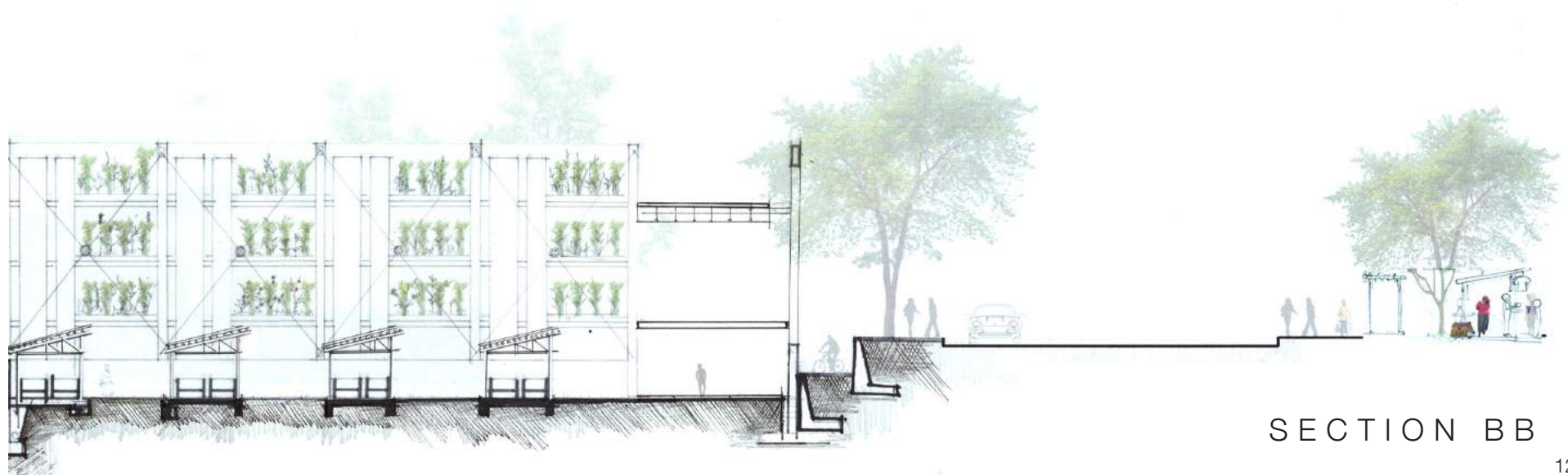

SECTION BB

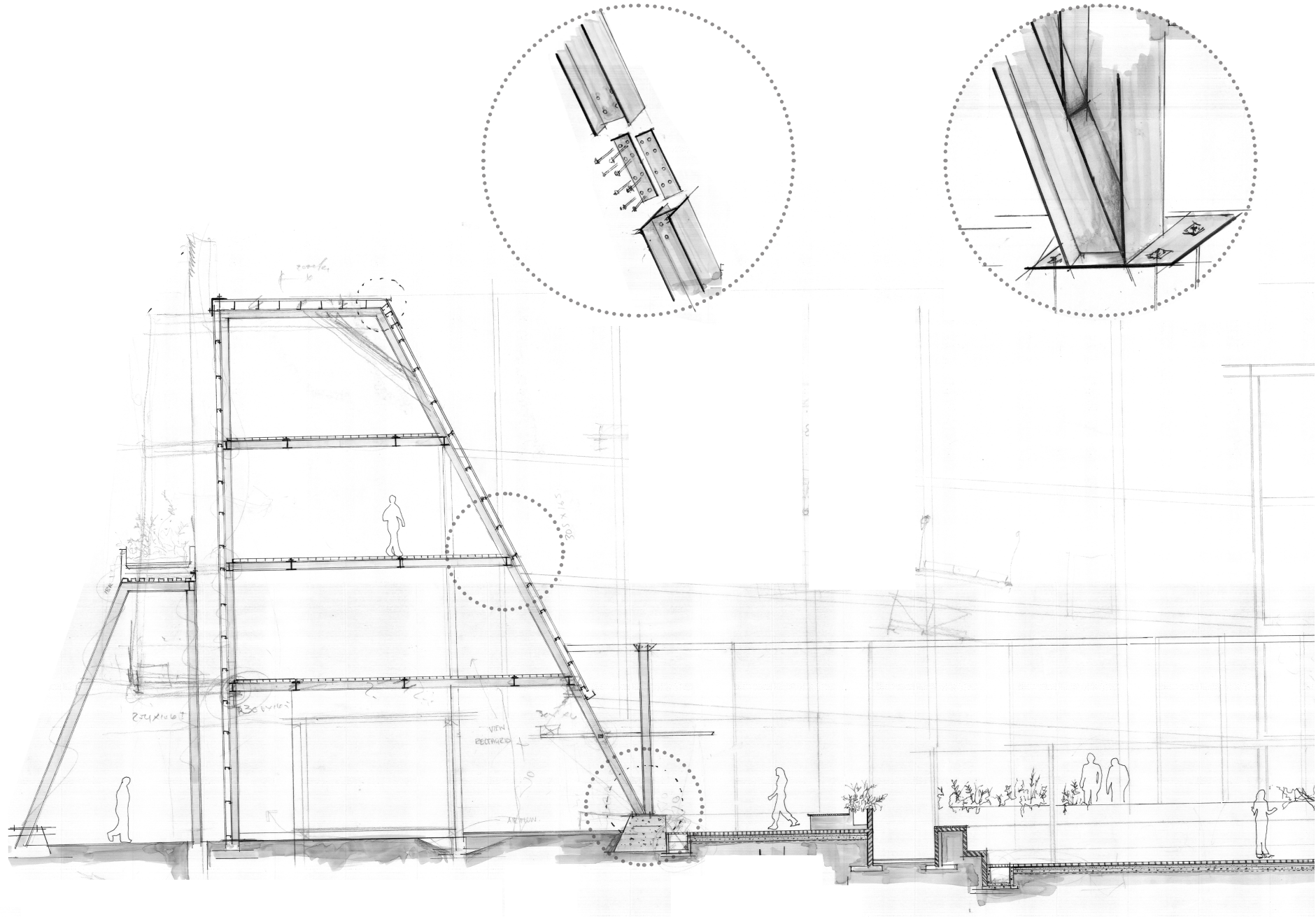

## september critique

---

Experiment with more materials.

Rethink conceptual focus in regards to technical investigation.

Important to show water harvested as it is essential to the project.

Bus stop requires a lot more attention.

Show a better understanding of materiality and structure.

Could the structure become something more? Experiment a bit with it.

Passive systems not shown and are important to the scheme.

---

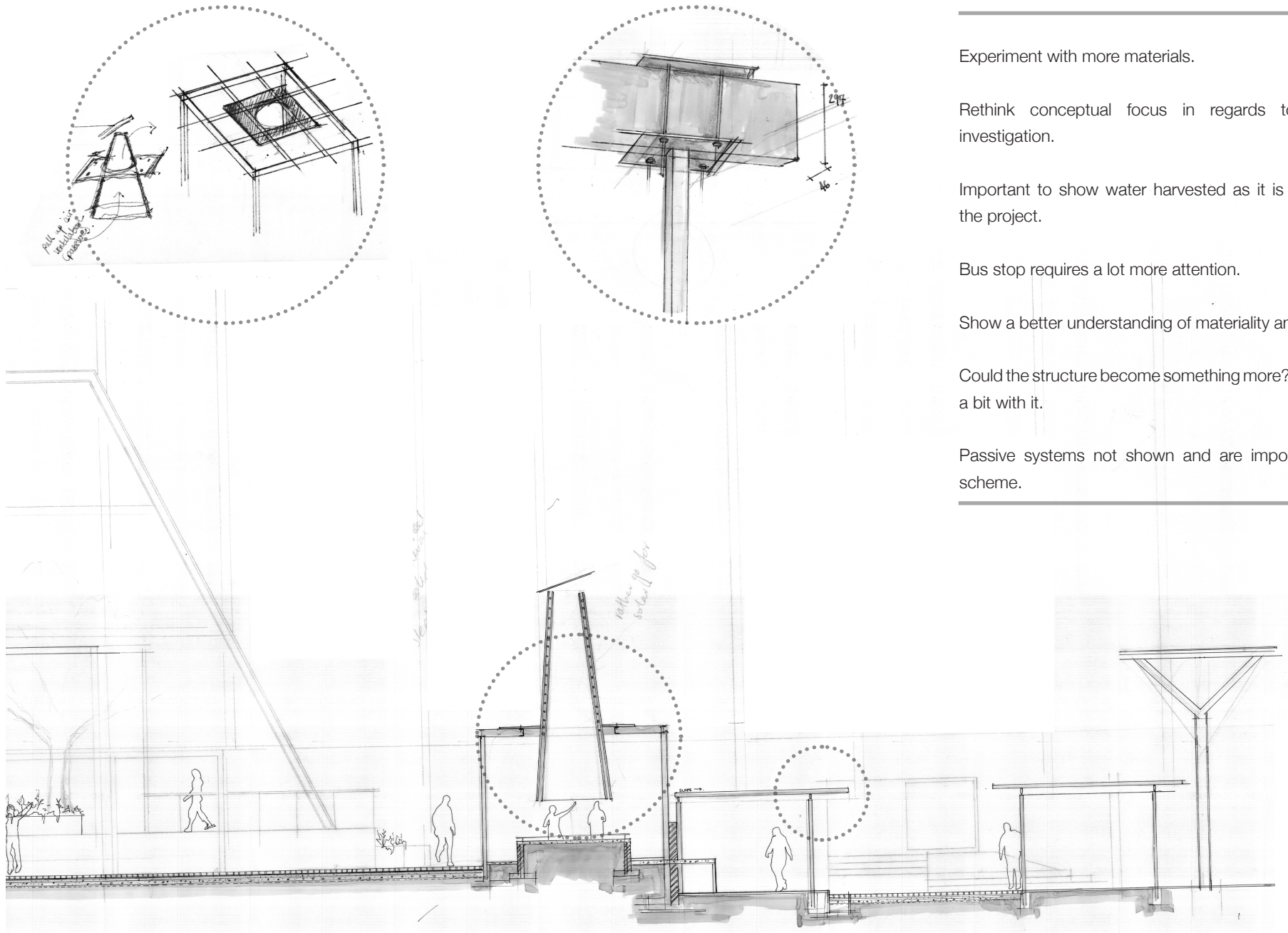

# RE[GROW]TH

## REVISED TECHNICAL CONCEPT

from the ground up

Due to the nature of the site it is important to develop the language through a contextual manner which highlights the over-arching idea of social, economical and physical re[grow]th. Dual functionality becomes a large consideration in order to create adaptable and less restricted contextual and functional conditions.

The aim is to find a balance through structural means that promotes both ends of the spectrum, informal and formal, by merging the high tech demands of the food production system with the innovative low tech solutions found within the context in order to create a resilient and empowering socio-economic space.

Owing to the space being a highly interactive one the structure needs to be resilient in order to endure a variety of conditions and activities. From the ground up, the structures will transition from a heavy robust nature, such as the roots of a plant, to a more sensitive and temporal one, such as the leaves, with regards to both materiality and structure.

The structure, stem of the plant, thus facilitates the amalgamation of the two contrasting construction notions and how together they contribute to the overall wellbeing of the space.

IMPERMANENCE

GROWTH

GROUNDED

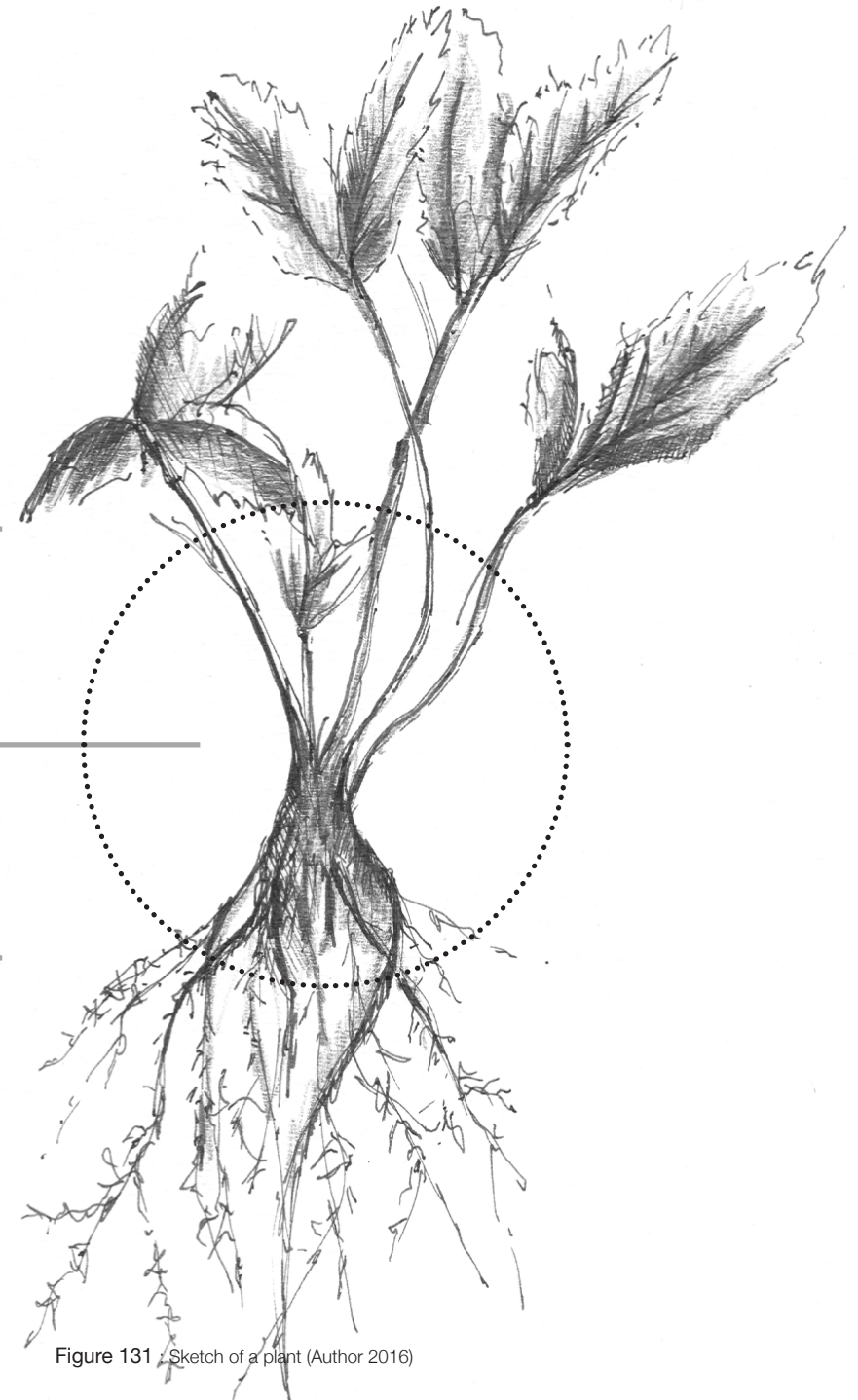
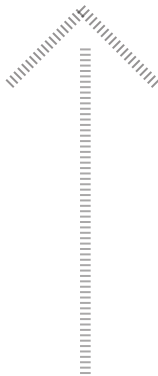

Figure 131 Sketch of a plant (Author 2016)

temporary construction  
informal (plastic view)

---



L I G H T

---

permanent construction  
formal (woodlands boulevard)

---



H E A V Y





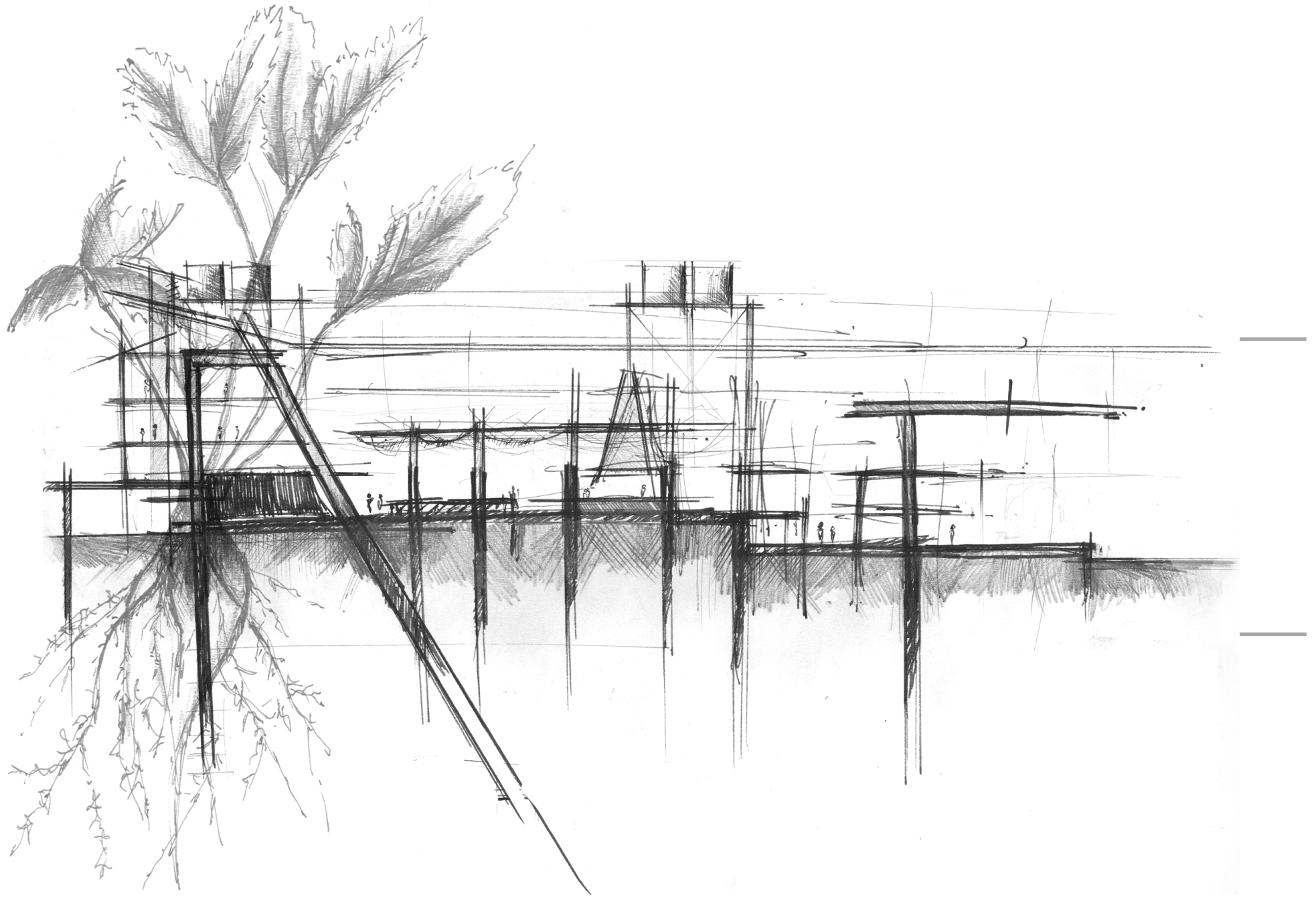

TECHNICAL TRANSLATION:

fragile  
mono-functional

small vs large scale tectonics  
delicate connections

LIGHT

AMALGAMATION

TECHNICAL TRANSLATION:

robust  
dual-functionality

fine vs large grain stereotomics  
sturdy connections

HEAVY

## MATERIALITY

from the ground up

The concept is reflected in the material palette which predominately includes plastic, steel and brick. The aim is to play the materials off of one another in order to emphasise their differences as well as demonstrate the manner in which they can be integrated. The brick and plastic are more contextual and readily available where as the steel is not as prominent, especially within the settlement. The palette includes the merging of man-made and natural elements allowing for a successful connection to the urban fabric.

The overall intention of the scheme, to optimise food systems through the reduction of waste, is carried through into the construction. Due to steel being such a heavy element, the investigation and use of recycled materials where deemed appropriate, is validated.



Figure 132 : On site materiality photos (Author 2016)

### RECYCLABLE BRICKS

Along side Plastic View is a large dumpsite consisting of bricks and pieces thereof. The bricks are discarded as it is forbidden for residents of Plastic View to build anything permanent. They are, however, used for purposes such as paving and the definition of property boundaries.

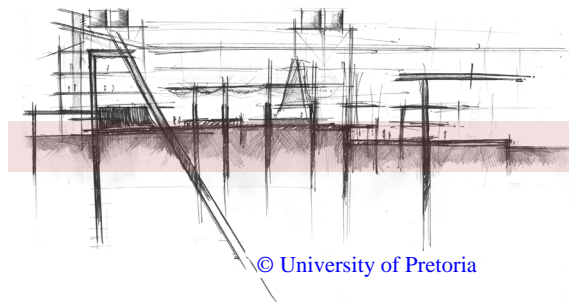

### PLASTIC SHEETING

Plastic sheeting is the most predominant material used in Plastic View.

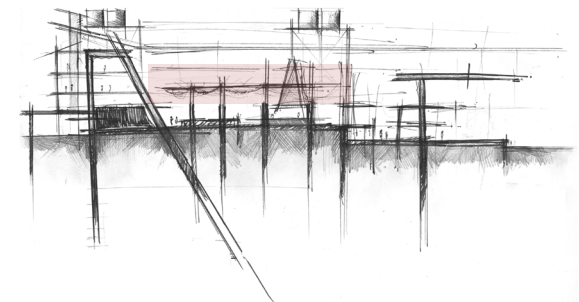



---

## CORROGATED SHEETING

---

Corrugated sheeting is a commonly used material throughout the informal settlement. Discarded sheets are found and recycled into walls and roofs.



---

## TIMBER

---

Discarded timber offcuts are used structurally used to build the small dwellings.



---

## STEEL

---

Steel elements are used to highlight new technology and changes within the context. It also aids in acknowledging structural elements present in Woodlands Boulevard.

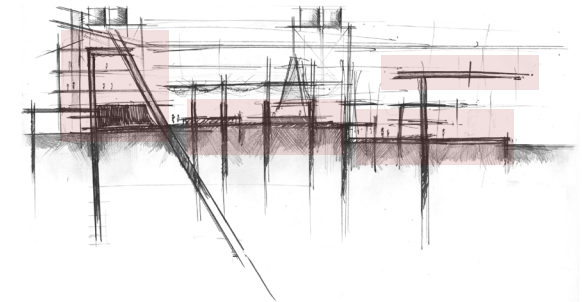
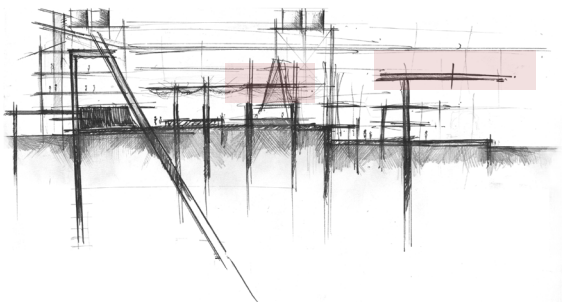

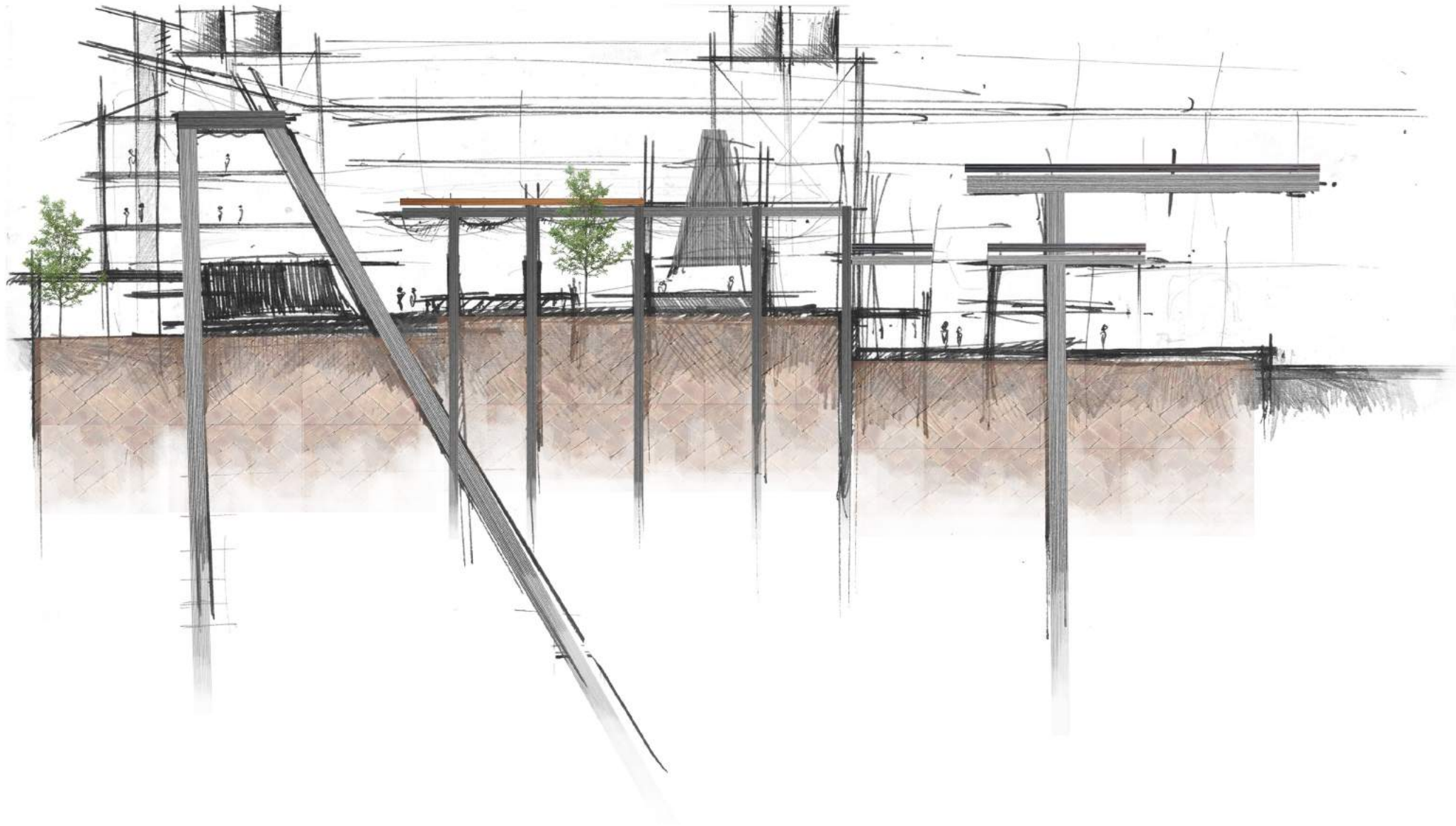

CONTEXTUAL MATERIALITY  
INFLUENCE



IMPLEMENTED MATERIALITY

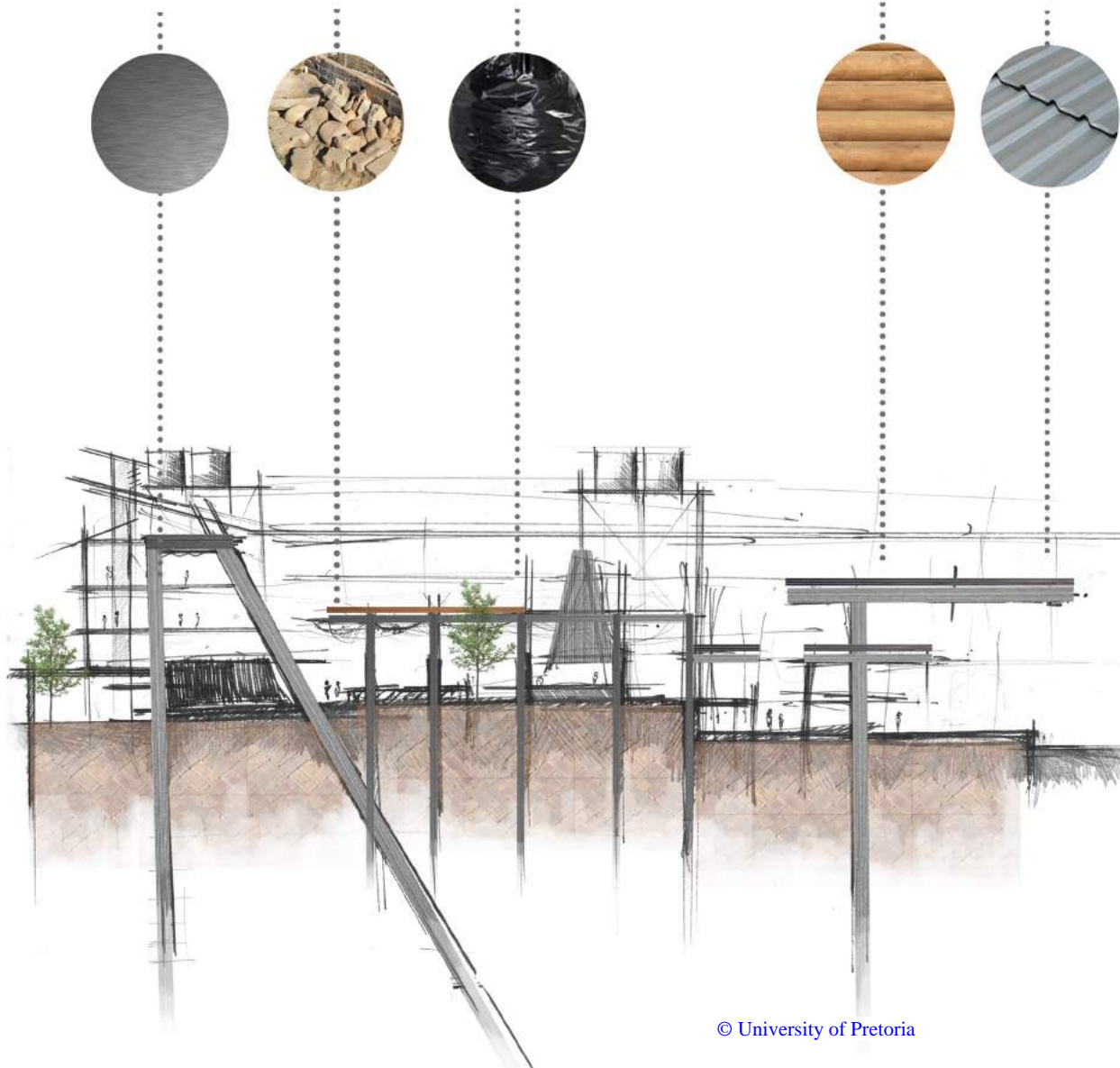

## SUSTAINABILITY

from the ground up

The design is built upon the requirement to optimise systems through the reduction of waste and thus it is only appropriate that the design conceptually reflects this.

Conceptually, the design aims to incorporate the variety of materials on site in a manner that enhances their differences but displays them in a manner that allows them to stand on their own.

With regards to sustainability, an investigation into composite materials was done in order to compensate for the large amount of steel being used. The project thus uses the contextual material influence but explores other means by which to represent these materials.

# 92%

## UNRECYCLED PLASTIC WASTE\_GLOBALLY

300 million tonnes of plastic is discarded annually on a global scale of which only 8% is recycled. A sizeable contributing factor, in terms of food production, is the packaging used. The plastic packaging reduces food waste as it keeps products fresher for longer periods of time, improves transport efficiency and reduces packaging mass.

The steadily increasing amount of plastic waste is raising awareness and strengthening the demand for a more sustainable packaging material as well as the need to recycle the substantial amount of plastic waste already available (Gourmelon 2015).



Figure 133 : Unrecycled plastic waste at a global scale (Author 2016)



## PLASTIC RECYCLING

the lack thereof

---

Plastics are durable, lightweight and inexpensive materials, which enables them to be easily moulded into a large variety of products. As a result of this, plastic production, over the past 60 years, has increased remarkably (Thompson et al 2009a).

Approximately 4 per cent of the global gas and oil production, a non-renewable resource, is spent as feedstock for plastic production and an additional 3-4 per cent is used for the energy needed for the manufacture thereof (Dvorak, Hopewell & Kosior 2009).

---

---

Due to the levels at which plastics are currently used and produced, which far outweighs the disposal, has created many environmental issues that has led to the usage of plastics being unsustainable (Thompson et al 2009b). As a result of the durable nature of the plastics, significant quantities of rejected plastics are gathering as debris within the landfills and in worldwide natural habitats.

There are as many as 7 types of plastic, however, only 3 types of plastic (1-3) are commonly processed due to high processing expenses, safety concerns and toxicity of the other 4 (Indiegogo 2016).

---





## BYFUSION\_PLASTIC BRICKS

100% recycled

---

Peter Lewis is the engineer-inventor of ByFusion, a 100% modular technology platform that converts all the various types of plastic waste into neat blocks called RePlast, that are a new alternative material for building (Chowdhury 2016).

The process is an eco-friendly, non-toxic and low carbon emission method to upcycle discarded plastic into a new usable product and the machine itself is modular and can easily be transported to wherever it is needed (ByFusion 2016).

---

As a building material, RePlast blocks are 100% recycled due to the machine is able to process all 7 types of plastic. The ByFusion technology allows for the production of blocks with the same sizing and dimensions of common concrete blocks that are designed to accommodate a large variety of development, infrastructure and construction projects.

Blocks range from 3.5 -12kg of plastic depending on the use for the brick and approximately 7000 bricks can be produced daily. The bricks are configured in order to stack like lego blocks, which eliminate the need for

---

adhesives or mortar and thus represent a new approach to sustainable construction (DiStasio 2016). The bricks can be covered by chicken mesh and plastered for desired effects.

With technology as such and the devastating increase in pollution and waste it seems only fitting to incorporate RePlast as a building material or this project. Plastic can be used straight from landfills and can also be collected from the oceans and coastlines diverting millions of tons of the plastic waste from the landfills (Chowdhury 2016).



Figure 135 : plastic waste (ByFusion 2016)

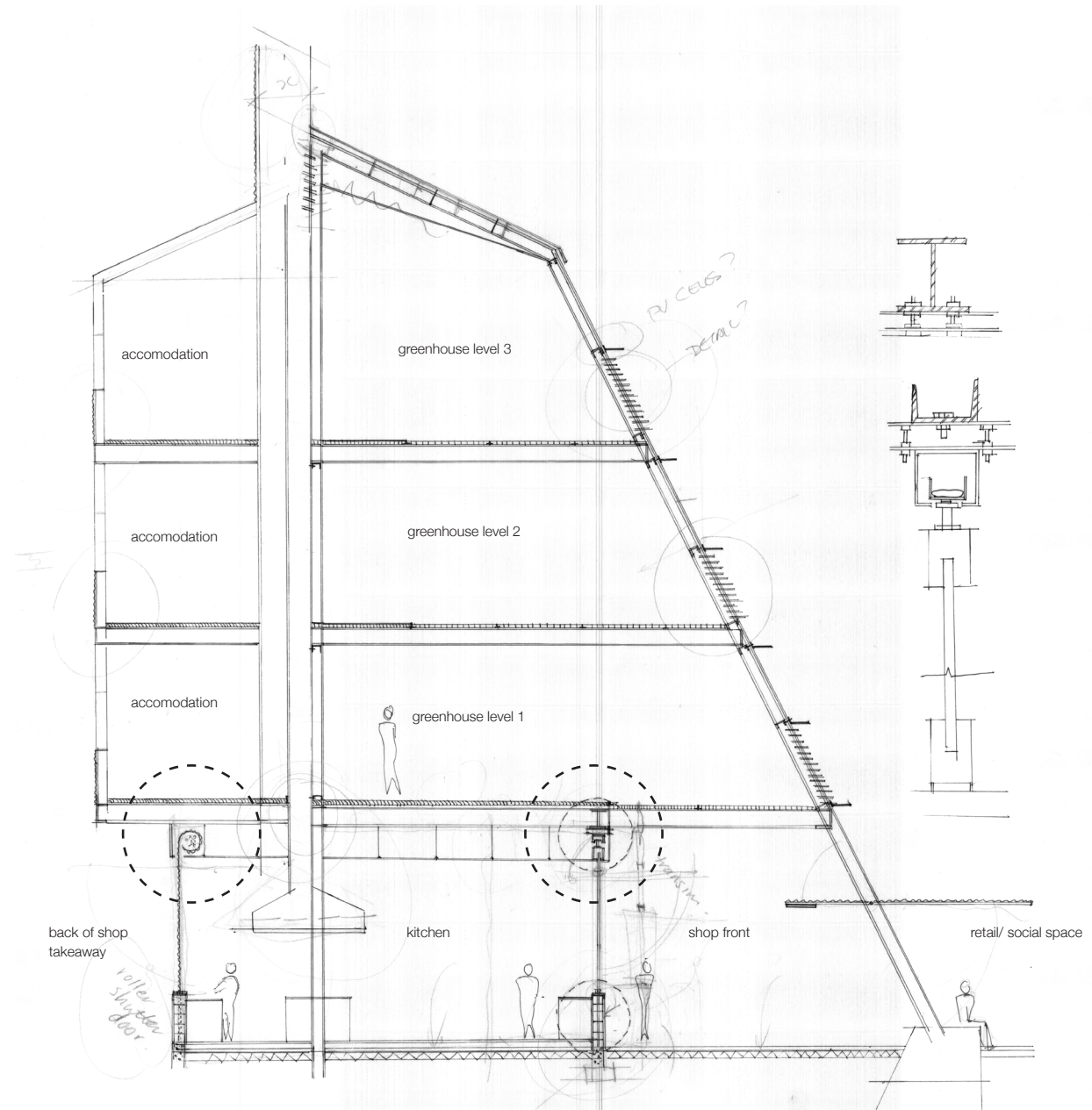

Figure 136 : ByFusion bricks (ByFusion 2016)



Figure 134 : ByFusion bricks manufacturing (ByFusion 2016)

- 95% lower greenhouse gas emission than concrete block.
- Better sound and thermal insulation capabilities than a concrete block.
- Flexible manufacturing process. Various sizes, shapes and colours.
- Cost effective to build and scale.
- Streamlined processing. No sorting or pre-washing required. Plastic gets shovelled straight into the machine for the process to begin.



## greenhouse development

The greenhouse, the focal point of production, is the most technically advanced aspect of the design with regards to its materiality and hydroponic system within.

In order to develop the production core on a more human scale the materiality used on ground floor will be contextual as well as robust.

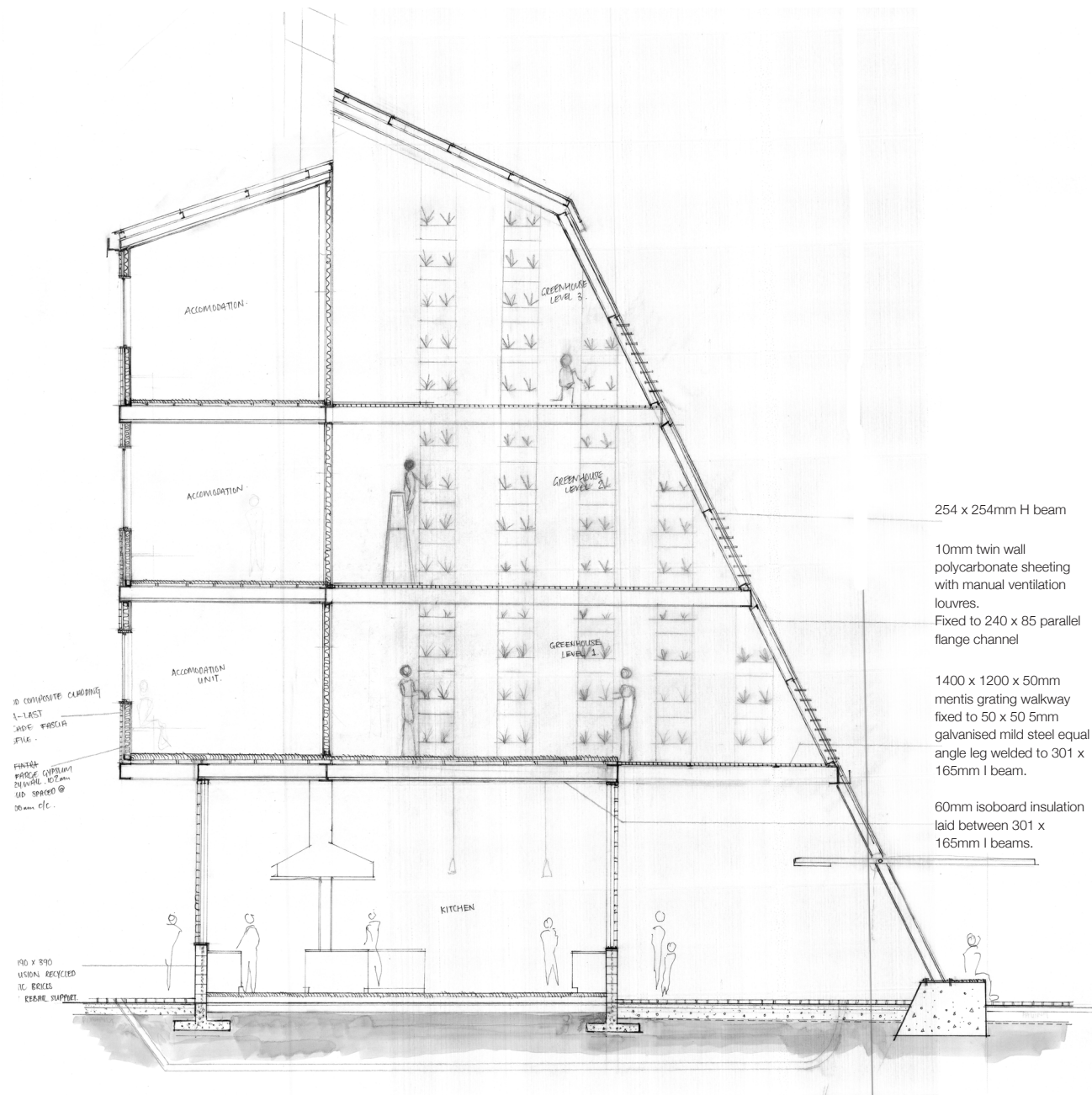

The greenhouse is more simplified in terms of materiality. The roller shutter doors make way for large sliding windows that enable the ground floor to open up fully and allow for movement within and through the space

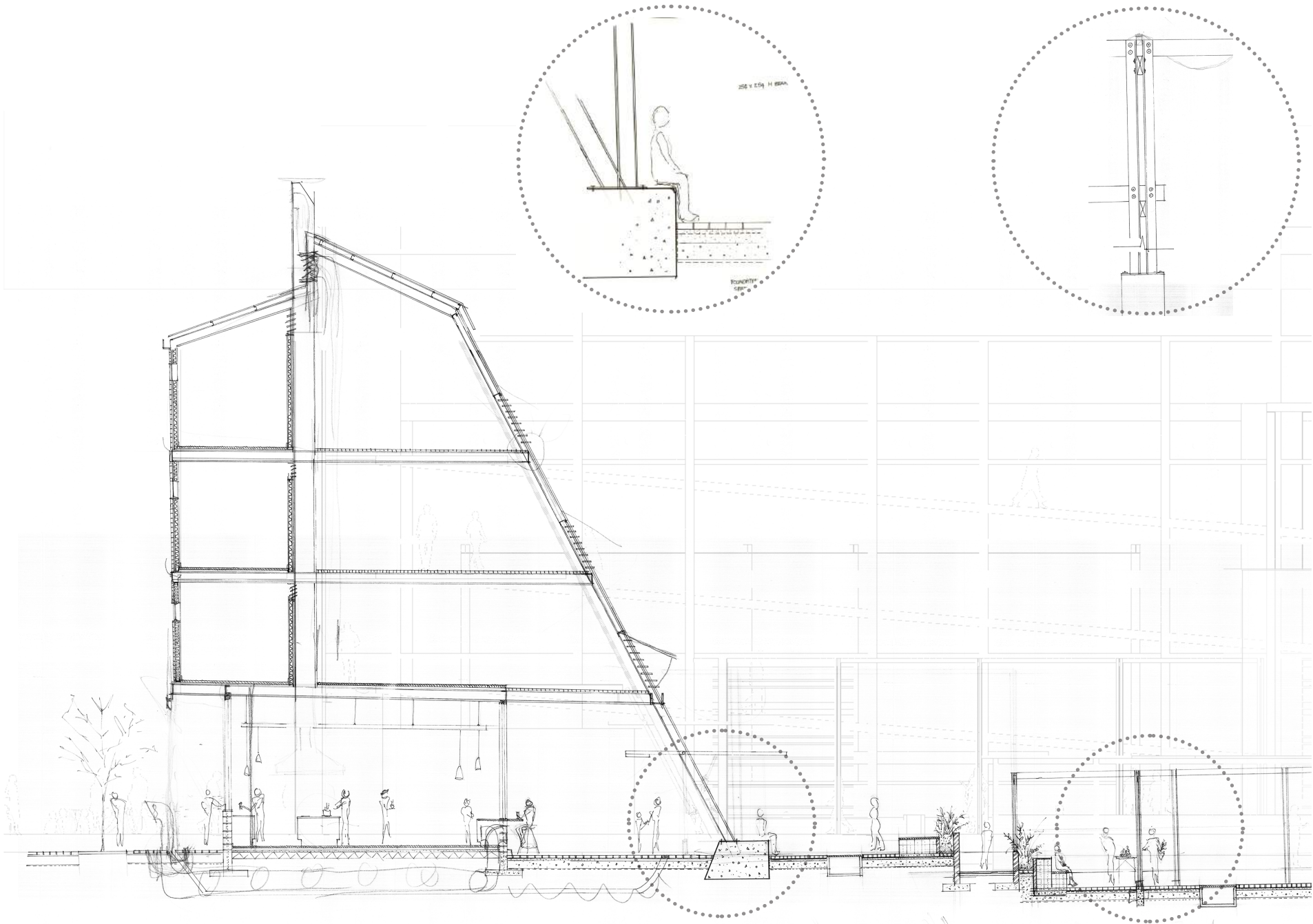

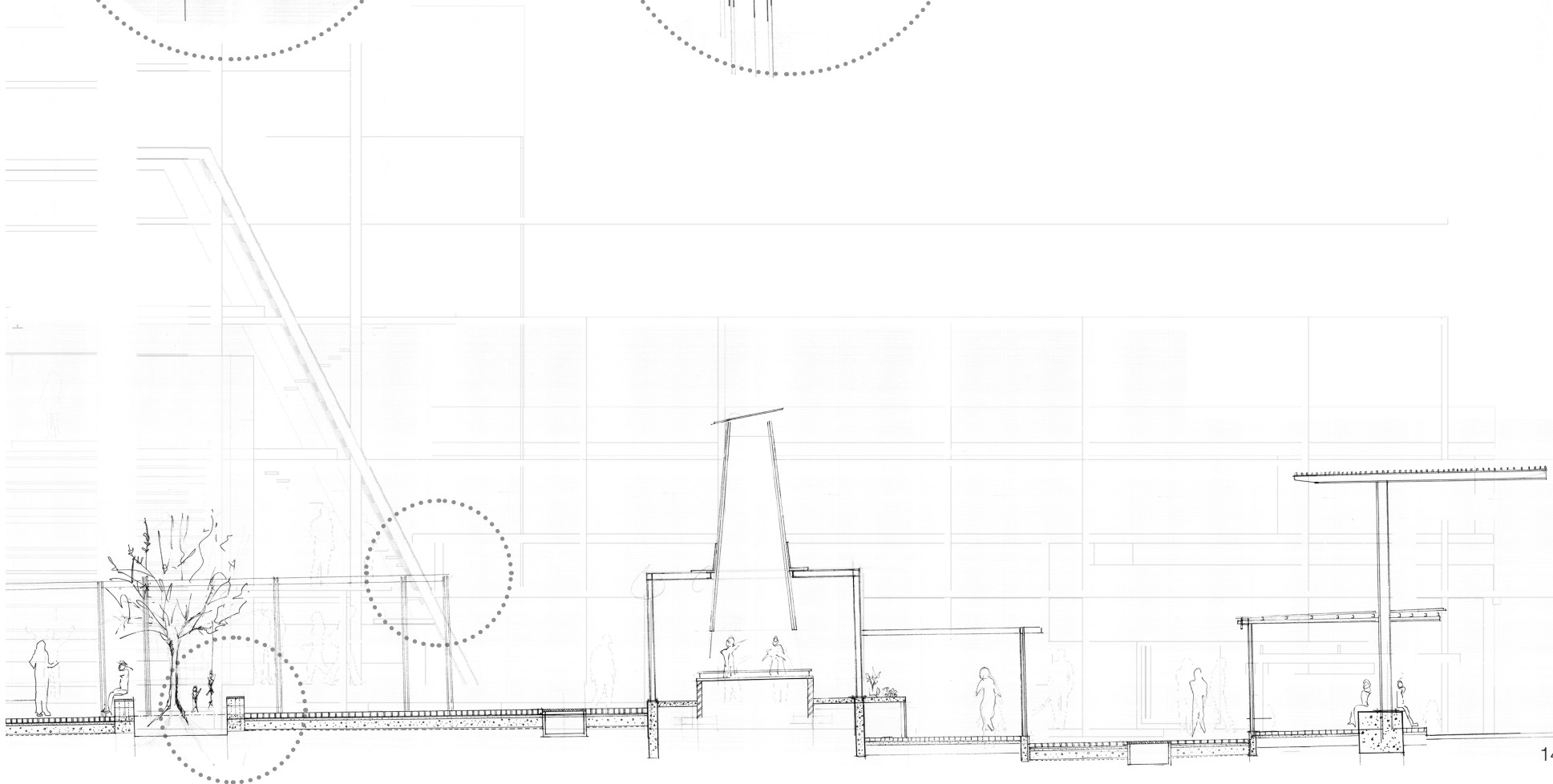
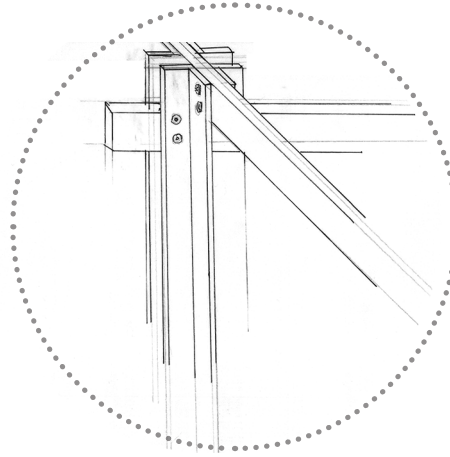
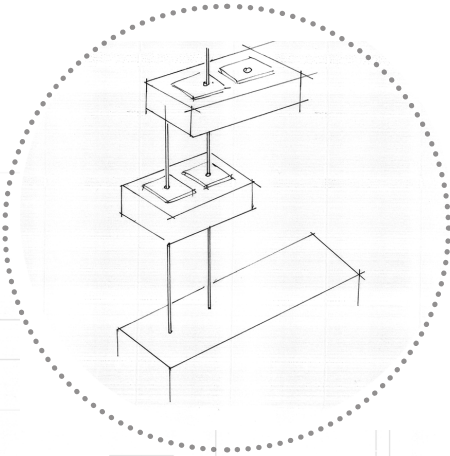

## SUSTAINABILITY

from the ground up

Sustainable systems are integrated into the design process to allow for the building to fit within its context.

Due to the context and nature of the design, sustainability is a large issue. Large water and energy requirements must be met and thus rainwater harvesting and passive energy systems are a large focus.

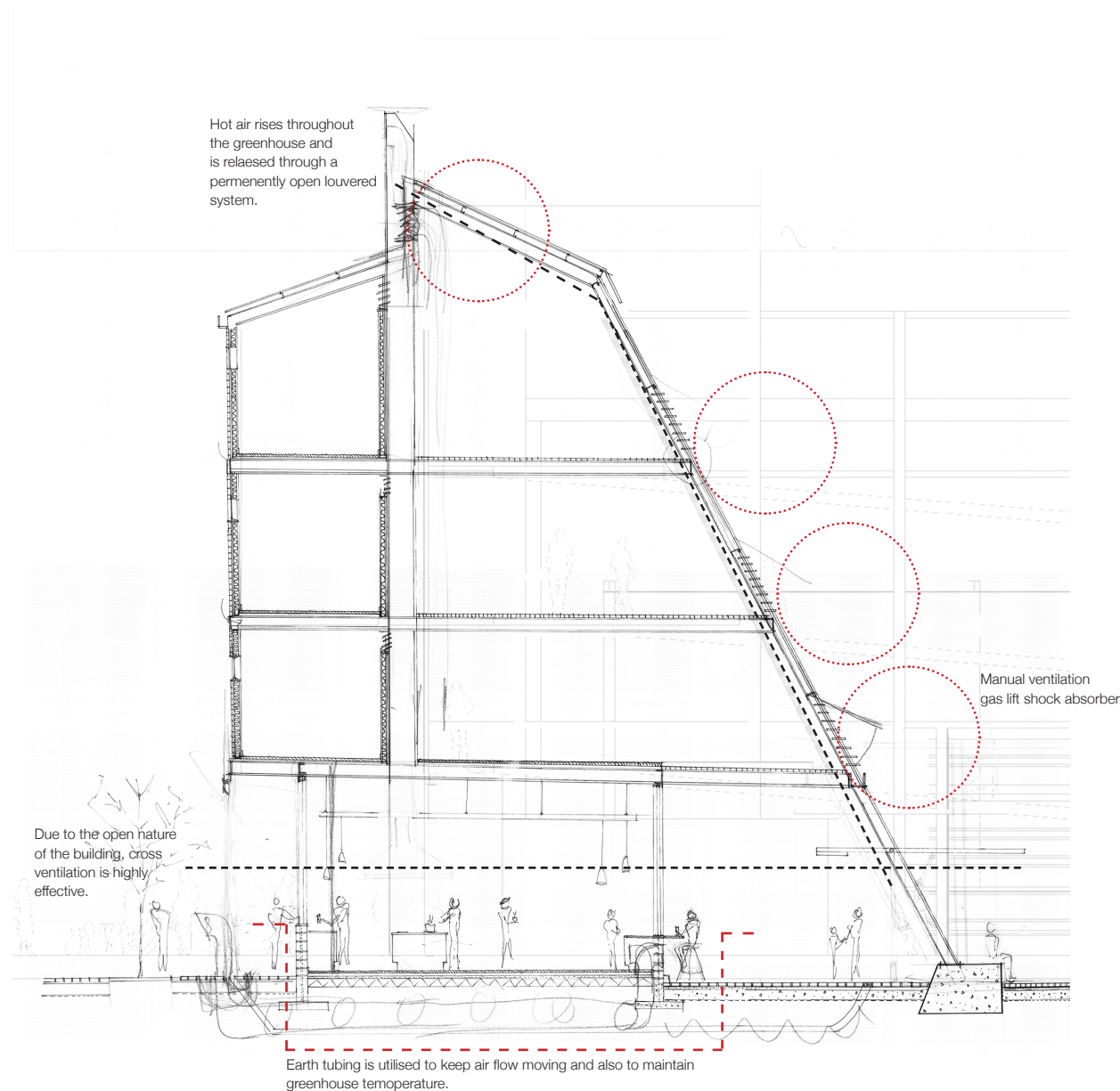

BIODIGESTER SIZE: 20 m<sup>3</sup>  
58,968 kw/h daily



ENERGY SOURCE\_ABLUTION FACILITIES