

*Hautejardin*

Exploring the pre-fabrication of landscapes through the  
process of making

by Megan Mathey



UNIVERSITEIT VAN PRETORIA  
UNIVERSITY OF PRETORIA  
YUNIBESITHI YA PRETORIA



*Haute jardin*

Exploring the pre-fabrication of landscapes through the process of  
making

By Megan Mathey

Study leader                      Johan N. Prinsloo

Studio master                     Johan N. Prinsloo

Course co-ordinator             Dr. Arthur Barker

Submitted in fulfilment of part of the requirements for the degree Master  
of Landscape Architecture (Professional)

Department of Architecture, Faculty of Engineering, Built Environment  
and Information Technology, University of Pretoria, South Africa

November 2016

In accordance with Regulation 4 (e) of the General Regulations (G57) for dissertations and theses, I declare that this dissertation, which I hereby submit for the degree Master of Landscape Architecture (Professional) at the University of Pretoria, is my own work and has not previously been submitted by me for a degree at this or other tertiary institution.

I further state that no part of my dissertation has already been, or is currently being, submitted for any such degree, diploma or other qualifications.

I further declare that this dissertation is substantially my own work.

Where reference is made to the work of others, the extent to which work has been used is indicated and fully acknowledged in the text and list of references.

Megan Mathey

October 2016

# Abstract

The hand thinks while it builds. Only by physically grappling with a material does one truly understand what it wants to become. In contemporary landscape architecture, there is typically a separation between the act of designing and the act of making, often causing a lack of practical knowledge of the capabilities of materials and their relationship to one another.

To construct expressively means to comprehend a material's physical properties and how its process of production is revealed through repetition and exaggeration. This dissertation attempts to explore the pre-fabrication of landscapes through an iterative process of making by hand with the goal of uncovering material properties that would otherwise remain concealed. It starts with a material exploration on a detailed level, after which the resulting artefact is applied in the larger context of Pretoria. In addition, this exploration attempts to add to the very limited body of work concerning landscape architectural tectonic theories.

# Uittreksel

*Die hand dink wanneer dit bou. Slegs deur fisies met 'n materiaal te wroeg verstaan mens waarlik wat die materiaal wil word. In eietydse landskapargitektuur is daar tipies 'n verdeling tussen die daad van ontwerp en die daad van maak, wat dikwels lei tot 'n gebrek in praktiese kennis oor die geskiktheid van materiale asook hul verhouding tot mekaar.*

*Uitdruklike konstruksie dui op 'n begrip van 'n materiaal se fisiese eienskappe en die tentoonstelling van sy produksieproses deur repetisie en oordrywing. Hierdie skripsie poog om die voorafvervaardiging van landskappe te verken deur die herhalende proses van maak met die hand, met die doel om materiaalskappe te ontdek wat andersins geskuil sou bly. Dit begin met 'n materiaalverkenning op 'n detail vlak, waarna die artefak toegepas word in die groter Pretoria konteks. Verder poog hierdie verkenning om by te dra tot die beperkte kennis van tektoniese teorie in landskapargitektuur.*

Programme

A kit-of-parts pavilion

Keywords

detailing, design process, kit-of-parts, parametric design, pavilion, pre-fabrication , product design, textiles



UNIVERSITEIT VAN PRETORIA  
UNIVERSITY OF PRETORIA  
YUNIBESITHI YA PRETORIA

# Table of contents

List of figures

Chapter	<b>1</b>	Introduction	
		1.1 Background	11
		1.2 Problem statement	12
		1.3 Research objectives	12
		1.4 Thesis statement	12
		1.5 Project overview	12
		1.6 Definition of terms	14
Chapter	<b>2</b>	Research methodology	
		2.1 Making	15
		2.2 Hybrid research	16
		2.3 Practice-based research	16
		2.4 Action Research	16
Chapter	<b>3</b>	Tectonic theory and textiles	
		3.1 Introduction	19
		3.2 The poetics of making	19
		3.3. Landscape architectural tectonics	22
		3.4 Textile tectonics	23
Chapter	<b>4</b>	Phase 1: textile fabrication	
		4.1 Introduction	25
		4.2 Process of discovery: hand-knitting	26
		4.3 Reflection and revised plan-of-action	33
Chapter	<b>5</b>	Phase 2: textile manipulation	
		5.1 The art of fabric manipulation	35
		5.2 Process of discovery: folding	35
		5.3 Reflection and revised plan of action	38
Chapter	<b>6</b>	Pavilions	
		6.1 The pavilion: a testing vessel and curatorial object	41
		6.2 Pavilions as garden art	42
		6.2.1 Gazebos	44

	6.2.2 Buildings	44
	6.2.3 Tents	44
	6.3 Contemporary pavilions	45
	6.3.1 Emergence and functions	45
	6.3.2 Typology	46
	6.4 Pavilion structures in Pretoria	47
	6.5 Programming the pavilion	48
	6.6 Reflection and revised plan of action	48
Chapter	<b>7</b> The application of the canopy as part of a pavilion	
	7.1 Textile canopy	51
	7.1.1 Modelling techniques	51
	7.1.2 Design logic	52
	7.2 Structural grid	56
	7.3 Reflection	56
Chapter	<b>8</b> The making of the pavilion	
	8.1 Introduction	65
	8.2 Textile pockets	67
	8.3 Structure	67
	8.3.1 Scaffolding	68
	8.4 Plant selection	73
	8.5 Lighting	73
	8.6 Textiles as display surfaces and space-definers	79
	8.7 Water	79
	8.8 Seating	82
	8.9 Surface as extension of the landscape	83
Chapter	<b>9</b> Application of the pavilion	
	9.1 Introduction	87
	9.2 Pavilion in the park	92
	9.3 Pavilion on an urban rooftop	93
	Conclusion	101
	References	103
	Appendices	107

# List of figures

- Figure 1: Auguste Choisy's diagrams of Doric order stone construction and its wooden origins (1899:288)
- Figure 2: The square lashing of wooden poles by means of rope is not only functional, but it results in a pattern and repetition that is aesthetically pleasing (Author 2016)
- Figure 3: Impression of the highveld (Author 2016)
- Figure 4: Research methodology (Author 2016)
- Figure 5: Stacked stone forming curved retaining walls in Osaka, Japan (Author 2016)
- Figure 6: Joinery of pergola elements at the Fushimi Inari shrine, Kyoto, Japan (Author 2016)
- Figure 7: Stone abutment at Shinkyo bridge, Nikko, Japan (Author 2015)
- Figure 8: The mechanisms by which textiles interact with the landscape (Broughton 2012:28-34)
- Figure 9: Textiles used in the landscape as functional elements as described by Broughton (Author 2016)
- Figure 10: Possibilities of applying sample 1 as spatial element (Author 2016)
- Figure 11: Sample 1 (Author 2016)
- Figure 12: Space-defining elements (after Ching 2007)
- Figure 13: Sample 2 (Author 2016)
- Figure 14: Sample 3 (Author 2016)
- Figure 15: The arm-knitting process (Author 2016)
- Figure 16: Spatial possibilities of a robust textile such as sample 2 (Author 2016)
- Figure 17: Spatial possibilities of sample 3 (Author 2016)
- Figure 18a: Sotho woman wearing *shweshwe* (HelenOnline 2014)
- Figure 18b: Folded *shweshwe* (Author 2016)
- Figure 19: Selected folding samples (Author 2016)
- Figure 20: Conceptual vision of a planted canopy as an immersive experience (Author 2016)
- Figure 21: Examples of gazebos and garden buildings (Author 2016)
- Figure 22: Examples of tent structures (Author 2016)
- Figure 23: 2016 Serpentine Gallery Pavilion, by BIG. London, England (Author 2016)
- Figure 24: Vertical linear spatial layout of typical rotundas (Author 2016)
- Figure 25: Vertical configuration of gazebos that require permeability (Author 2016)
- Figure 26: Instant land-scapes installed by communities or private individuals (Author 2016)
- Figure 27: Types of intervention sites (Author 2016)
- Figure 28: Iterative modeling using computer software (Author 2016)

Figure 29: Pavilion composition (Author 2016)

Figure 30: Conceptual model acting as a *parti* diagram (Author 2016)

Figure 31: Textile pavilion as provider of immersive experience (Author 2016)

Figure 32: Pavilion as provider of immersive experience (Author 2016)

Figure 33: Pavilion as provider of services (Author 2016)

Figure 34: Immersive experience with plants and textiles (Author 2016)

Figure 35: An elevated textile base plane adding to a unique user experience (Author 2016)

Figure 36: Selected iterations of the structural component of the pavilion (Author 2016)

Figure 37: Linear pavilion acting as threshold and gathering space (Author 2016)

Figure 38: Textile plant pocket module (Author 2016)

Figure 39: Dior Spring/Summer 2014 collection set design (Tododesign 2014)

Figure 40: Dior Spring/Summer 2015 collection set design (Dirand 2015)

Figure 41: Dior Fall/Winter 2015/2016 collection set design (Dior 2015)

Figure 42: Louisiana Hamlet Pavilion, by Selgascano (Selgascano 2015)

Figure 43: Pavilion MMM (Design With Company 2014)

Figure 44: Planted textile canopy (Author 2016)

Figure 45: Composition and density of PRO-MIX™ HPCC Mycorrhizae

Figure 46: Forces exerted by canopy on supporting structure (Author 2016)

Figure 47: Salvatorpassage hanging plant canopy, by Herzog & De Meuron (Subtilitas 2011)

Figure 48: Kimono Forest at Arashiyama Station, by Yasumichi Morita (Author 2016)

Figure 49: Through Hollow Lands installation by Lilienthal | Zamora (Lilienthal 2012)

Figure 50: Plant selection (Author 2016)

Figure 51: The use of textile panels as vertical space-defining element at the 2009 Liceo Opera House exhibition (Cadaval & Sola-Morales 2009)

Figure 52: Agricultural shade netting used as screens to define space (Author 2016)

Figure 53: Agricultural shade netting used as space-defining elements (Author 2016)

Figure 54: Floor panels as water-retaining elements (Author 2016)

Figure 55: Seating (Author 2016)

Figure 56: Knotting as textile logic (Author 2016)

Figure 57: Biological, physical and anthropological forces acting on the landscape (collage by Author 2016)

Figure 58: Change in surface over time (Author 2016)

Figure 59: Bamboo weathering (Bamboo Import Europe 2016)



Figure 60: Venning Park's reflection pond (top) and sunken garden (bottom)

Figure 61: Parts of the pavilion (Author 2016)

Figure 62: Details (Author 2016)

Figure 64: Thin-film photovoltaic cell (Sanyo 2013)

Figure 65: Position of pavilion indicated on the plan of Venning Park (Department of Parks and Recreation 1991)

Figure 66: The pavilion in Venning Park (Author 2016)

Figure 67: Park pavilion parts (Author 2016)

Figure 68: Section perspective of park pavilion (Author 2016)

Figure 69: Location of the pavilion as an urban rooftop intervention (Author 2016)

Figure 70: Rooftop event space at the Prinschurch building (Author 2016)

Figure 71: Views from the Prinschurch roof to Sammy Marks Square (top) and the South African National State Theatre (bottom) (Author 2016)

Figure 72: Pavilion on the Prinschurch roof (Author 2016)

Figure 73: Rooftop pavilion parts (Author 2016)

Figure 74: Rooftop pavilion in isolation (Author 2016)

Figure 75: Perspective view of the rooftop pavilion (Author 2016)



UNIVERSITEIT VAN PRETORIA  
UNIVERSITY OF PRETORIA  
YUNIBESITHI YA PRETORIA

# Introduction

# 1

## The nature of materials, making and detailing

### 1.1. Background

If you think of Brick, you say to Brick: “What do you want, Brick?” and Brick says to you: “I like an arch.” And if you say to Brick: “Look, arches are expensive, and I can use a concrete lintel over you. What do you think of that, Brick?”

Brick says: “I like an arch”. —Louis Kahn

The nature of materials has an influence on the manner in which they are used in construction. As structural elements, bricks perform best as arches, while timber elements are most economically used perpendicular to one another, as seen in traditional Japanese architecture. This has spatial implications: arches and domes form a different spatial experience to the linearity of lintels, and timber decking results in a rectilinear geometry. Construction details extend beyond nuts and bolts; they can reveal and memorialise construction methods, and this can lead the user to understand the built landscape and how it is made. For example, the triglyphs of Greek temples of the Doric order were made of stone, but were retained in the form of the wooden beams that would once have supported the roof (Tucci 2015:245; see figure 1). Can this influence the conventional design process that landscape architects follow?

Historically, architects were considered master builders, being both designers and craftsmen. In contemporary landscape architecture, there is typically a separation between the act of designing and the act of making, often causing a lack of practical knowledge of the capabilities of materials and their relationship to one another. This is perhaps the reason behind the recent increase in design-build workshops and -courses taken by students of spatial design; only by building does one truly understand construction.

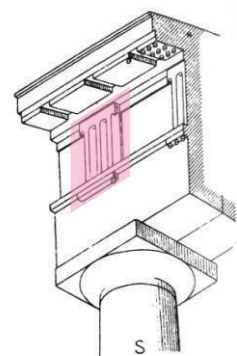
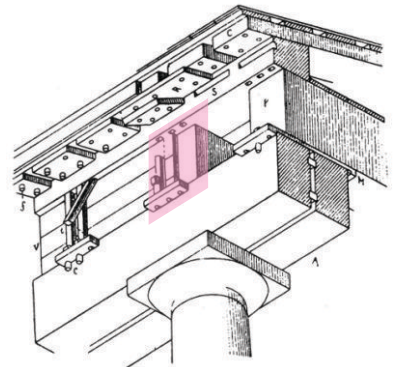

Figure 1: Auguste Choisy's diagrams of Doric order stone construction and its wooden origins (colour added by author)

## 1.2 Problem statement

Tectonic theories aim to explain how materiality and the art of construction can play a central role during the building design process. However, there is not a well-known body of work regarding the art of constructing landscapes. This knowledge is important as the design of robust yet expressive elements in public spaces requires an understanding of materiality and making.

## 1.3 Research objectives

The aims of this dissertation are:

1. To explore a design process that starts with detailing and material exploration.
2. To follow a research strategy based on hand-making and prototyping as design tool.
3. To investigate, apply, and contribute to the current body of knowledge regarding landscape architectural tectonic theories.

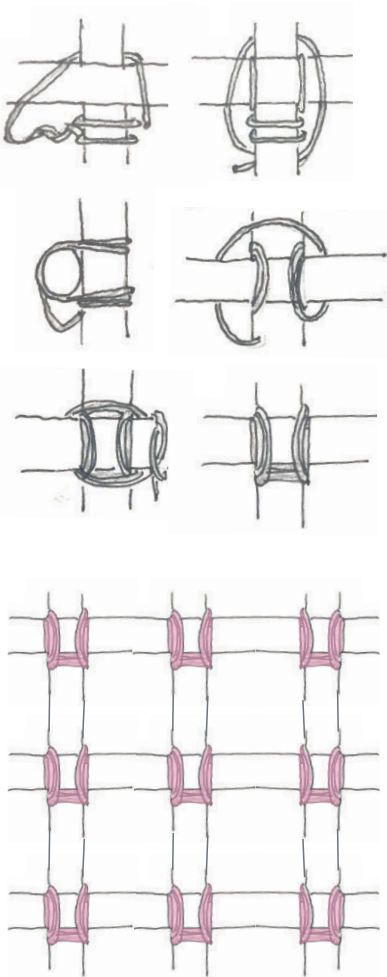

Figure 2: The square lashing of wooden poles by means of rope is not only functional, but it results in a pattern and repetition that is aesthetically pleasing (Author 2016)

## 1.4 Thesis statement

Detailing and the joining of materials can inform the physical appearance of a built landscape on a larger scale, reveal its context and show the user the construction methods followed in its fabrication. This can be optimised by prioritising detailing as a starting point of the design process. Furthermore, an understanding of the material identity of a region will enable detailing representative of its setting. By actively incorporating making as a design tool, landscape architects can discover the potential of the materials available in an area. A landscape architectural tectonic theory will add to the knowledge gained through this process.

## 1.5 Project overview

The design process is initiated by theory and design ideals, and, as such, a programme, site and users are only identified at a later stage. The process of discovery reveals opportunities and constraints as the designer progresses.

A set of criteria is established at the start of each phase of investigation.

A set of criteria is established at the start of each phase of investigation.

When the criteria are met, or when new information is discovered that could change the course of the design, the phase is reflected upon and responded to with an amended set of criteria. These criteria are a tool by which the investigations are measured against, and also act to control the time spent on each phase, which is a limiting factor due to the fixed duration of the study.

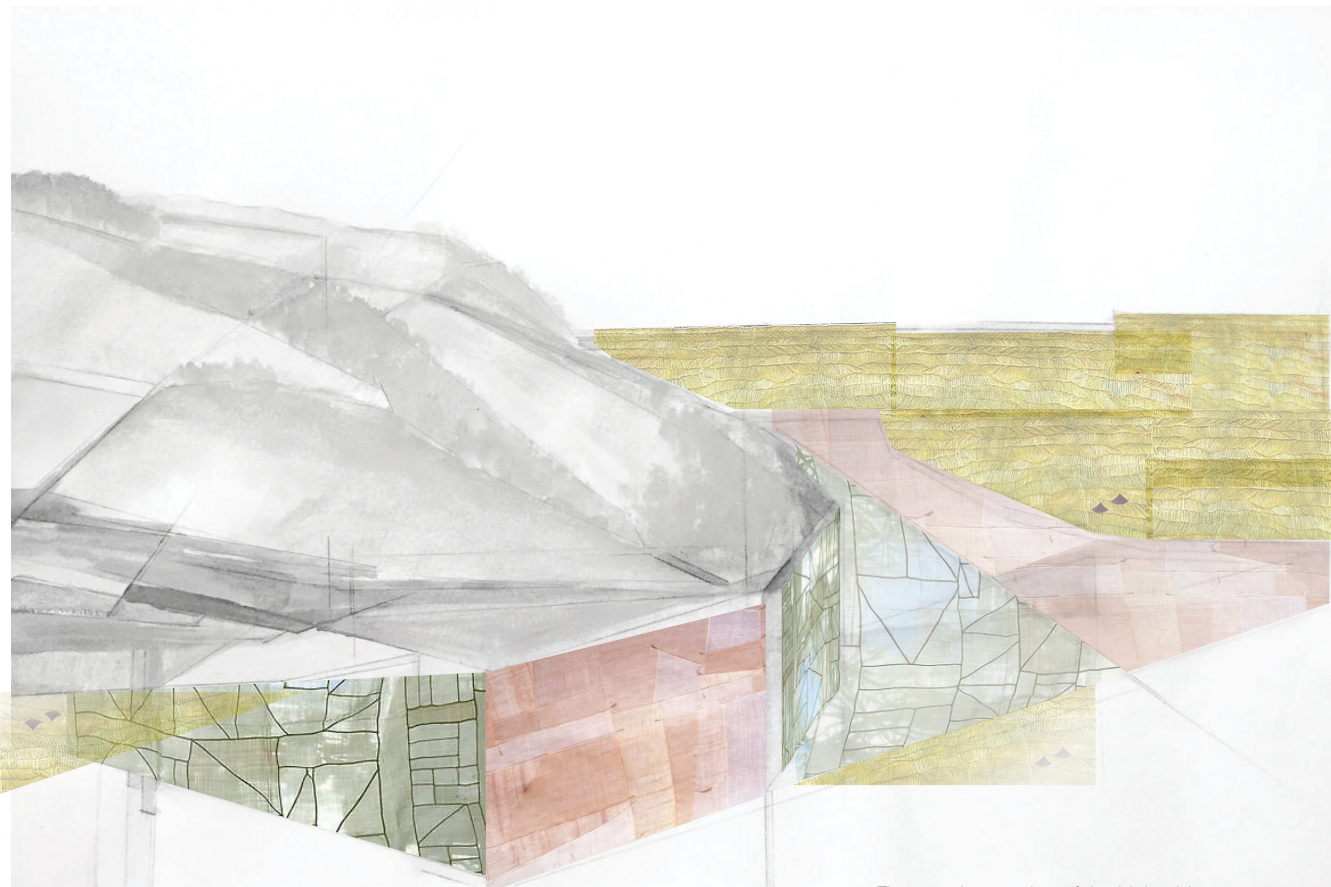

Figure 3: Impression of the highveld  
(Author 2016)



## 1.6 Definition of terms

detailing	the way in which two or more components of a landscape or building are joined
experiential (also phenomenology)	the experience of built space
expressive construction	using a material's properties to guide their aesthetic potential through patterns and repetition; the joining of materials in a functional yet aesthetic way (see figure 2)
fabrication	the making or building of an item or space
forces	natural phenomena that have an observable effect on the landscape, such as rain and water flow, wind and sunlight
hyperbolic paraboloid	an infinite surface in three dimensions, with hyperbolic and parabolic cross-sections
hypar	a hyperbolic paraboloid shape cut from the full infinite surface
immersive experience	when a user feels completely captivated by a space
kit-of-parts	a subcategory of pre-fabrication focusing on demountability, disassembly, and reuse
mountain fold	a crease where the paper or sheet-like material folds away from the crease
parametric design	the use of a computer to design objects by modelling their components with real-world behaviours and attributes
pavilion	a stand or structure often found in parks and other public spaces
poetics of construction	paying close attention to the joining of separate elements in a structure
pre-fabrication	manufacturing components of a structure and afterwards transporting them to a different site where the structure is to be located
space-definer	elements that imply form
stereotomic	elements of architecture and built landscapes that are perceived to be heavy and solid
<i>techne</i>	making useful objects by hand in an artful way
tectonic	elements of architecture and built landscapes that are perceived to be lightweight
tectonics	see poetics of construction
textile	a flexible material consisting of a network of fibres, formed by knitting, weaving, knotting, crocheting or felting
yarn	a continuous length of interlocked fibres

# Research methodology

# 2

## The art of inquiry

### 2.1 Making

How do we as designers ask a brick what it wants to be? Ingold (2013) answers this question by stating that human beings learn by doing. This emphasises the need for designers to engage with the objects and spaces they create, in the process that Ingold calls “the art of inquiry” (2013:6): “In the art of inquiry, the conduct of thought goes along with, and continually answers to, the fluxes and flows of the materials with which we work” (Ingold 2013:6). Thus, through the process of making, one observes, examines, reflects and resolves in a cyclical manner.

Technology has enabled novel ways in which to make objects, such as laser cutting and computer numerical control (CNC) milling. These methods are useful to represent final iterations, but are not the tools to which Ingold is referring. Physically grappling with a material is what makes a designer truly understand and test its possibilities and limitations. Pallasmaa (2009) refers to this as “the thinking hand”.

If good design requires making, then the very idea of a theoretical dissertation is problematic. There are numerous materials available to landscape architects, yet the physical investigation of their manipulation is limited to factors such as scale, funds and time. For this dissertation, the selection of materials for exploration is based on the tools available to the designer, and whether their manipulation can be done by the designer alone. Furthermore, the cost of the material needs to be covered by the designer which results in a selection of relatively affordable materials. Lastly, the duration of the study is limited to 9 months, which requires careful scheduling and decision-making that responds to this limitation.

This motivates the use of an alternative research methodology. The most commonly used design process followed in landscape architecture typically starts at the macroscale, then ends in the micro scale

(Kirkwood 1999:75). However, two additional approaches to design are proposed by Kirkwood (1999:75): from microscale to the macroscale, and a combination of the two. The making of an artefact as the starting point of a spatial design investigation is thus a valid alternative method to follow during design-based research (refer to figure 4 for an overview of the methodology followed).

## 2.2 Hybrid research

Wherry (2015:17) proposes a research strategy to be followed when a hand-made artefact is the creative outcome of a design-based research project. It is a hybrid research method that combines the practice-based research method and the action research method, and is based on planning, making, observing and reflecting, supported by thorough textual documentation and planning.

## 2.3 Practice-based research

Candy (in Wherry 2015:14) defines practice-based research as research by which knowledge is gained partly by means of practice, and where the artefact is the creative outcome of a project. The creative practices employed during this method of research act as the basis for theoretical inquiry and scholarly research (Nimkulrat 2012:2). This method thus encourages creative practice from the researcher, and the process of exploration and making provides the opportunity to generate research and knowledge (Candy & Edmond 2010:5).

Since the knowledge of the process of making is not evident in the object alone, the creative output produced as an integral part of the research process is accompanied by documentation. Textual analysis of the artefact and the process supports the position of the research and demonstrates critical reflection (Creativity & Cognition Studios 2015).

## 2.4 Action Research

Action research is the cyclical iterative process of an intention or plan, followed by an action, and completed by reflection on that action (Dick &





Swepson; Zuber-Skerrit in Wherry (2015:15)). Once a cycle is completed, a second cycle starts with a revised plan or intention.

Action research will assist with the act of making, as the iterative and documentation-based approach of the method will contribute to the development of a well-resolved artefact.

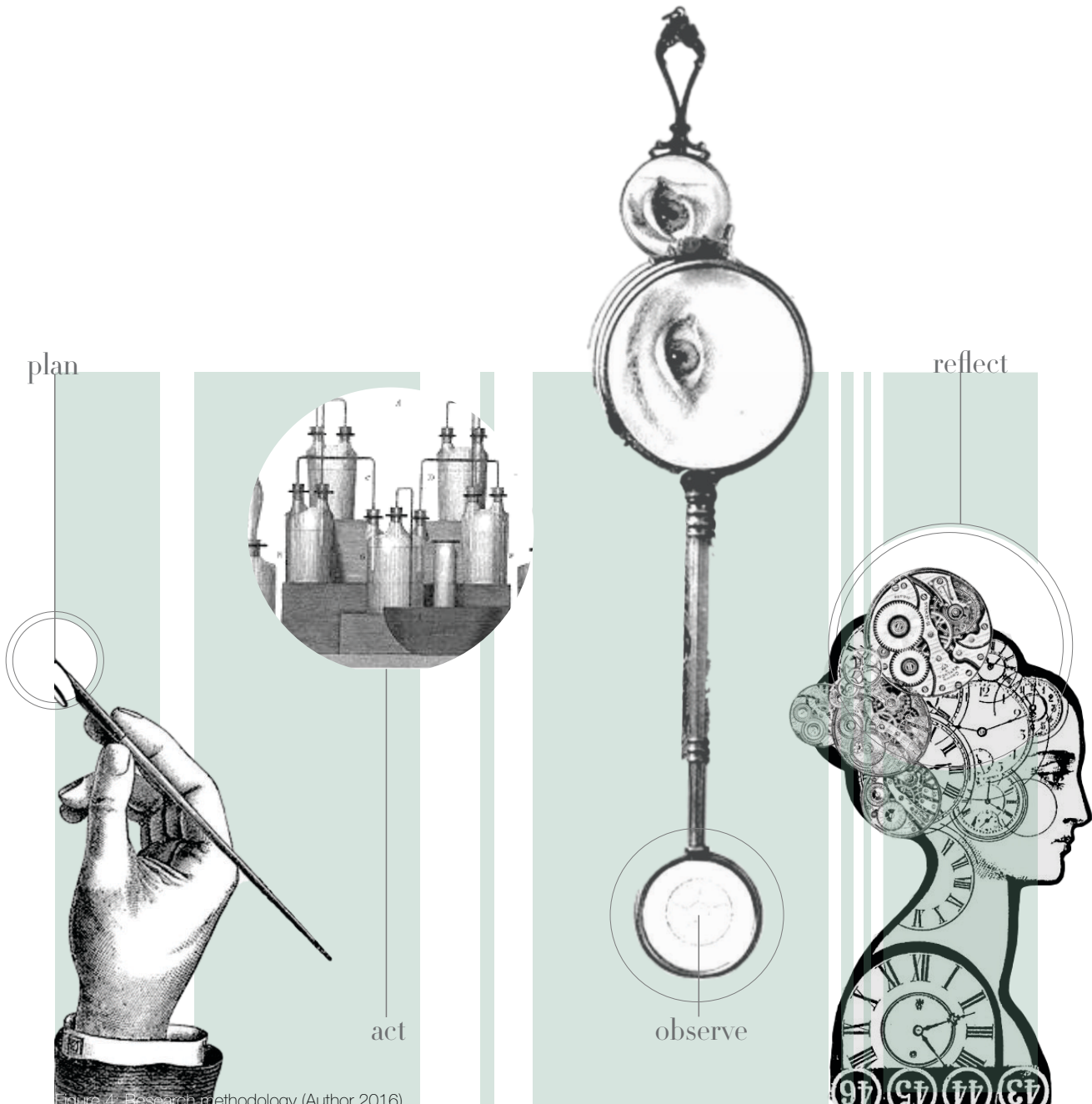

Figure 4: Research methodology (Author 2016)



# Tectonic theory and textiles

# 3

## The art of fabrication

### 3.1 Introduction

In *Studies in Tectonic Culture*, Kenneth Frampton devised a theory on the art of expressive construction in the field of. This can only be applied to landscape architecture to a limited extent, as there is a fundamental difference between buildings and landscapes, and that is the application and harvesting of forces that act upon them. Even though these forces are similar regardless of whether an artefact is a building or a landscape, the successful design of these spaces lies in the relationship that landscapes have to external elements. Buildings are designed to withstand natural phenomena such as wind, rain and sun. In contrast, landscapes require these very forces to sustain themselves. Because landscapes are in a constant state of flux, a unique tectonic theory needs to be devised for landscape architects as guidance for not only expressive construction, but also in embracing the dynamic nature of the natural environment.

"Architectural design is not about having ideas, but about having techniques, techniques that operate on a material level. It's about making matter think and live by itself."(Lars Spuybroek)

### 3.2 The poetics of making

The roots of tectonic theories in architecture can be found in the 1851 publication of Gottfried Semper's treatise *Die vier Elemente der Baukunst* (Frampton 1995:5). Semper divided building craft into two practices, the first being the joining of lightweight, linear components into a tectonic framework, and the second being the stacking of heavyweight elements to form stereotomic mass (Frampton 1995:5). Furthermore, Semper explained that the act of joining arose due to the intrinsic properties of the materials used in their execution (Broughton 2012:15). The materials thus determined the way in which things were put together, which, in turn, determined the appearance of the space they resulted in. As an example, stone can be used to create space simply by stacking, which results in undulating lines and spaces because no complex joining techniques are

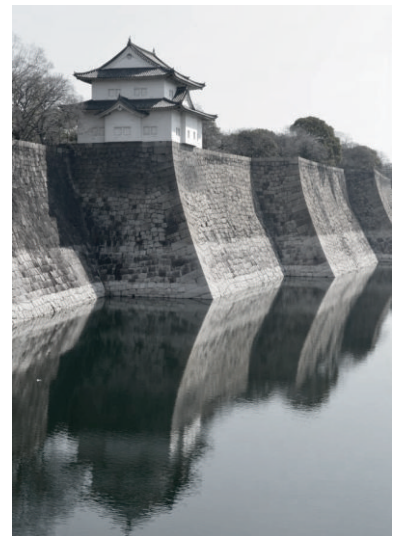

Figure 5: Stacked stone forming curved retaining walls in Osaka, Japan (Author 2016)



Figure 6: Joinery of pergola elements at the Fushimi Inari shrine, Kyoto, Japan (Author 2016)

required in its assembly (see Figure 5).

Heidegger (1977:1) states that *techne* is when “something concealed comes into un-concealment”; materiality and detailing can reveal construction techniques, and repetition and exaggeration of this can lead to patterns that further illuminate its fabrication. Even though Heidegger’s phenomenological approach is theoretical and philosophical in nature, and thus in opposition to this dissertation’s focus on making as learning tool, it can give a deeper insight into making as an act that extends beyond the artefact. Heidegger (1977:6-8) describes objects as a product of *techne* as having four “causes”: the *causa materialis*, the material; the *causa formalis*, the form that the material takes on; the *causa finalis*, the end use; and the *causa efficiens*, the maker. The materials that comprise constructed space reveal their processes of production, their constituent raw materials and the elements and forces that change them over time. Form as a product of *techne* refers to the character of the building or landscape: how it meets the earth and how its materials are joined together (Norberg-Schulz in Armstrong & Bell 2015). The maker refers to those who design and construct a building, landscape, or construction materials.

For example, wood is a commonly used material in traditional Japanese architecture due to its abundance. As a result, a vast number of joinery techniques have been developed by Japanese carpenters over a period of 1000 years, using the inherent characteristics of wood to fasten and secure timber members to one another without the use of glues or other fasteners (see figure 6 for an example of a recently built structure that makes use of historical techniques). The junctions range from simple to highly complex, and all require the skill of a set of craftsmen (Satoshi 2006:2-5). The wood used in Japanese architecture is naturally resistant to pests, and its darkening over time makes visible the forces that act on the material. Japanese joinery also influences the transmateralisation of timber to stone. Figure 7 illustrates the use of stone in the same manner that wood would have been used in the same structure. Thus, the *causa materialis* is wood as a reflection of its context; the forests as provider of materials, and stone as embodiment of wood joinery techniques. The *causa*



Figure 7: Stone abutment at Shinkyō bridge, Nikko, Japan (Author, 2015)



*formalis* is the rectilinear form that the structure takes on due to the way in which the wood members are joined together. Finally, the *causa efficiens* is the skilled carpenter that also acts as architect. Furthermore, because of the repetition of joinery throughout the wooden structure, an aesthetically appealing pattern emerges, making it an example of a craft form that combines functionality (the joining of wood to form a structure) with decoration (patterns and repetition).

Building on this, Kenneth Frampton attempted to further define and augment the tectonic theory in his *Studies in Tectonic Culture*, which centres around the “poetics of construction” (1995). This was in response to post-modern architecture (Mallgrave in Frampton 1995:ix), where the diverse architectural appearances were determined by the quirks of the architect and the meaning behind the building. Frampton's theory attempted to shift the focus of architecture away from theories of style, and back to the tangible and “material presence” (Soroka 1997:75) of spaces; from meaning to being.

In landscape architecture, there isn't a well-known theory of how landscapes ought to be constructed expressively. It will be insufficient to merely apply Frampton's theory to landscape construction, as there is a fundamental difference in the way buildings and landscapes exist, which is the nature of the elements acting upon them. Thus, a tectonic theory specific to landscape architecture needs to be developed.

### 3.3. Landscape architectural tectonics

Broughton (2012:1) states that a tectonic theory for landscape architecture has yet to develop, as no channel of discourse is dedicated to the relationship between construction and resultant form. As a result, she attempted to present a tectonic theory relevant to the discipline. Her theory focused on textiles, as “landscape architectural discourse offers little in terms of how textiles can be used as a material in landscape architecture” (Broughton 2012:4).

Broughton (2012:9) states that “in built landscapes the process of construction is doubled”, as elements constantly manipulate the designed

The word *textile* is from Latin *texere*, which means "to weave", "to braid" or "to construct" (Gillow & Sentance 2005:10).

would consider these elements to be destructive, Broughton (2012:39) claims that textiles have the ability to engage with these forces in a constructive manner: "By strategically utilising materials that can structure contingent environmental forces, landscape architects might configure these forces to work in support of their design intent" (Broughton 2012:39).

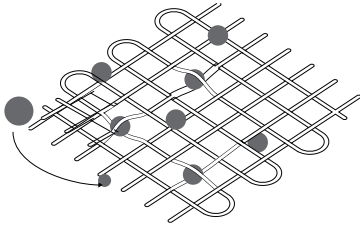

textiles that integrate materials

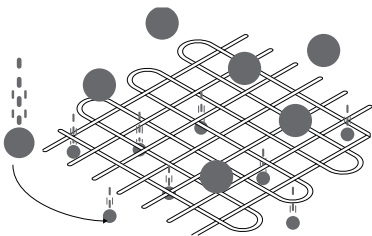

textiles that selectively filter

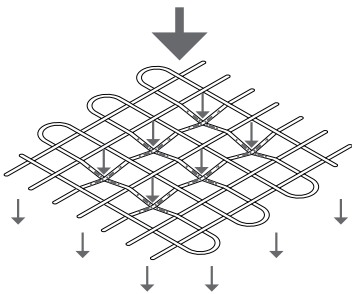

textiles that diffuse forces

Figure 8: The mechanisms by which textiles interact with the landscape (Broughton 2012:28-34)

Broughton justifies the decision to investigate the material properties of textiles in the landscape by referring to the importance of textiles in the development of an architectural tectonic theory. Semper described the role of textiles in early space-making in *Stoffwechselthese*, where he considered carpets, not masonry, to be the original separators of space in a home. It illustrates how "textiles have been transmaterialised into stone and steel and other constituent parts" (Spuybroek in Tramontin 2006:53), similar to the Doric temple triglyphs and stone bridge abutments discussed on page 11.

Not only do textiles have a history in the development of tectonic theories, but they also meet the requirements of the selection of materials for investigation in this study: they are commonly available, easily manipulated, and affordable.

### 3.4. Textile tectonics

Broughton focused the development of her tectonic theory on textiles as a material that integrates and responds to environmental forces, specifically their unique ability to absorb materials, selectively filter materials from flows, or to diffuse or slow forces (Broughton 2012:27) (see figure 9). The emphasis of Broughton's tectonic theory is thus on functionality and the response of this specific material to landscape forces (refer to figure 10). There is opportunity to build on this theory by focusing on the use of textiles as not only a functional material, but also as a space-defining element.

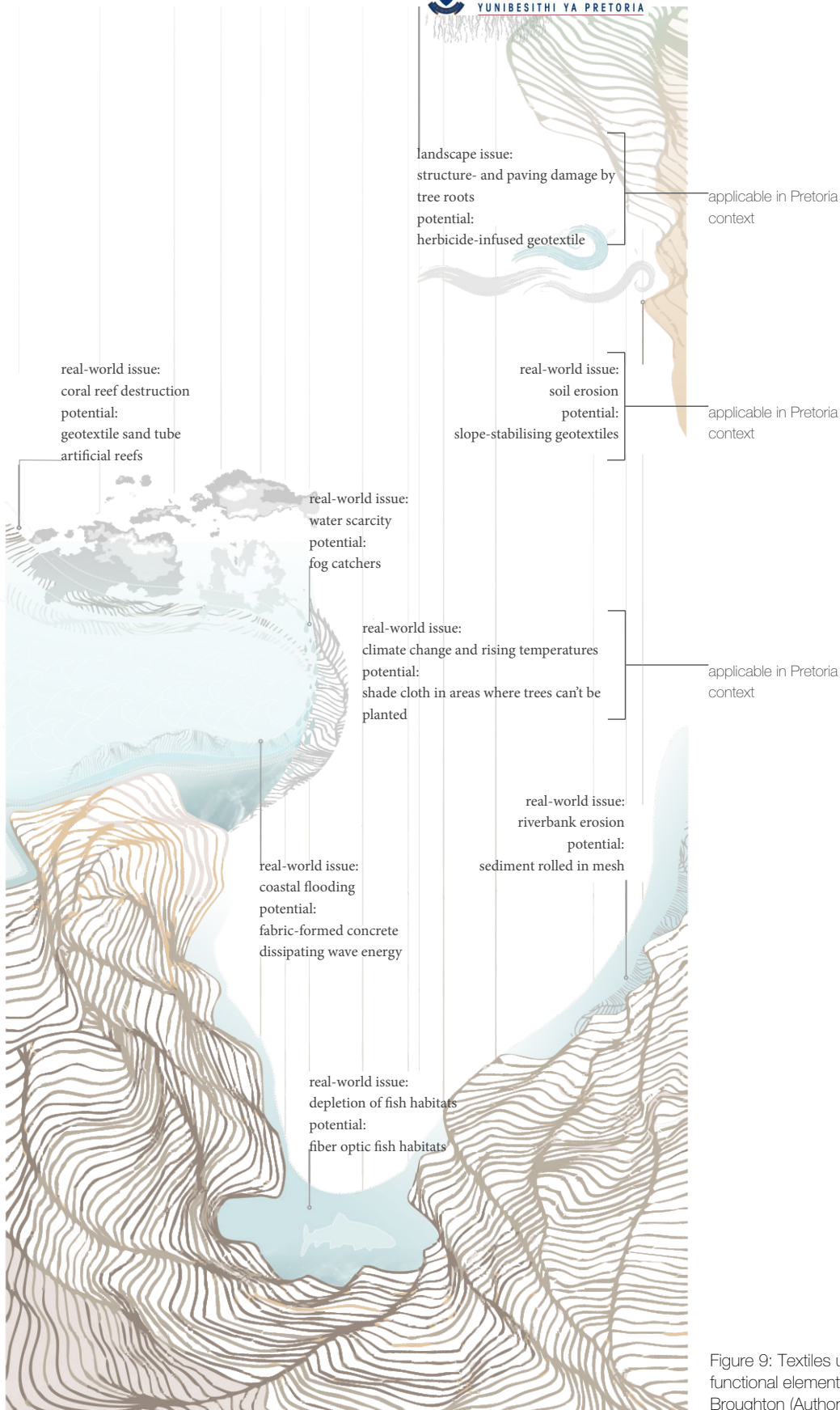

Figure 9: Textiles used in the landscape as functional elements as described by Broughton (Author 2016)



# Phase 1: textile fabrication

# 4

## Knowing through knitting

### 4.1 Introduction

The rationale behind using textile as a material for investigation was described in section 3.3 and 3.4. In the manner of Louis Kahn, the investigation set out to determine what form and programme the textile wants to be.

The first step to answering this was determining a suitable method by which textiles can be made by hand in order to explore their properties and fabrication. Textiles are manufactured by weaving, knitting, or felting. Felting is a method whereby wool or synthetic fibres are pressed together to form a textile. Weaving uses two sets of yarns that interlace at right angles, whereas knitting results in yarns that follow a meandering path that forms a symmetric loop. Arm-knitting (where the maker's arms replace the function of knitting needles) was chosen as the most appropriate process to follow, as the method is quick to learn, no tools are required, and the scale is such that a large enough artefact can be made to assess within a shorter period.

"Architectural design is not about having ideas, but about having techniques, techniques that operate on a material level. It's about making matter think and live by itself."(Lars Spuybroek)

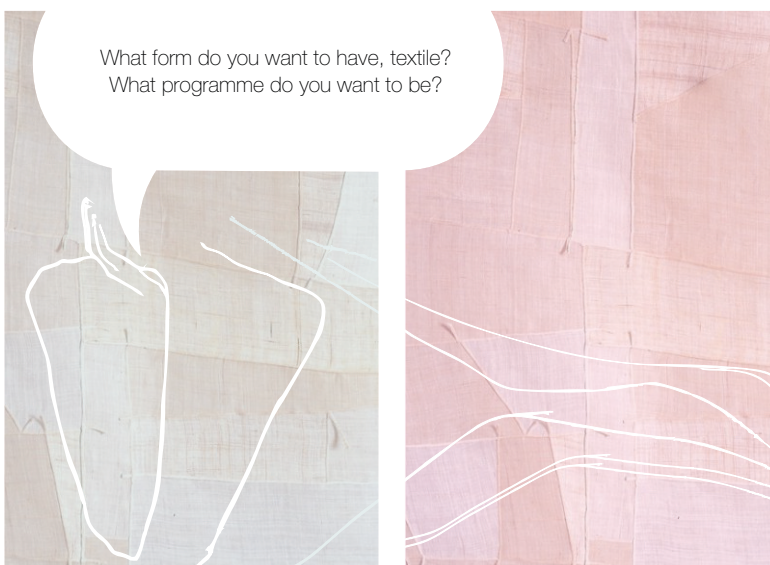

Secondly, the possible programme identified was based on Broughton's analysis of textile functions in the landscape (2012:28-34) (see figure 10). In a Pretoria context, geotextiles infused with herbicide can inhibit damage by tree roots to structures and paving. However, the textile is hidden and thus the investigation will not be appropriate. Another real-world issue applicable in Pretoria is soil erosion. Geotextiles that stabilise slopes are a solution commonly used in landscape architectural practise. These are visible and have the potential to be an aesthetic yet functional feature in the landscape. The final possibility is shade cloth, providing protection from the sun in areas where trees can't be planted or when shade is instantly required. The material used to construct the textile was based on yarn or rope commonly used in the landscape. Furthermore, in order for these textile elements to be functional as well as spatial, one must be reminded of spatial design principles, such as those described Francis D.K. Ching (2007) (refer to figure 12). These will help reveal the potential of the artefact as space-defining element.

#### 4.2 Process of discovery: hand-knitting

Sample 1 was created using 3mm polypropylene twine, a commonly used agricultural yarn, which was warp-knit based on 10 garter stitches. 100m of twine was used to create a sample with an area of 0.378 m<sup>2</sup>. The elastic properties of the sample cause irregularities in shape; there is expansion at points of restraint and contraction in areas with no contact to external support. Furthermore, the twine is too thin to provide sufficient shade, and the sample is weighed down at its centre of gravity, it appears drooping and malleable. In addition, the yarn-to-surface ratio is small.

The subsequent response to these observations was to use thicker twine for a sturdier sample and smaller stitch sizes to increase shading capacity. The opportunities provided by the sample are that it can have poetic and dynamic movement and shadow-casting properties on the overhead plane, and that it can be draped (see figure 10). Despite this, the question of how the sample is more appropriate than conventional shade structures presented itself, as the functional properties of shading are



Figure 10: Possibilities of applying sample 1 as spatial element (Author 2016)

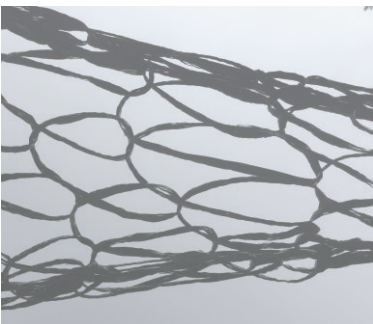

Figure 11: Sample 1 (Author 2016)

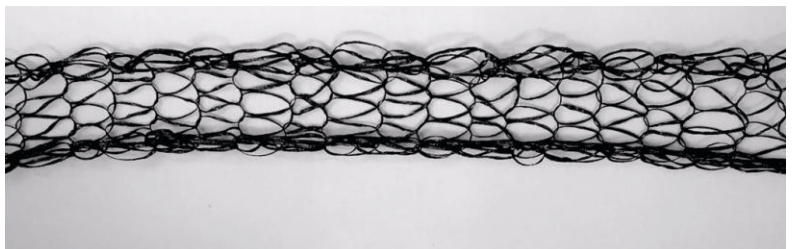
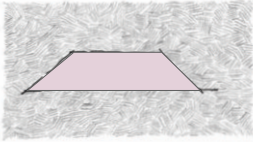

Figure 12 (following spread): Space-defining elements (after Ching 2007)



# horizontal elements

## base plane



"A base plane is a spatial field defined simply by a horizontal plane or figure placed on a contrasting background. Perceptible colour contrast, texture or tonal change between a surrounding area and a surface can define this spatial field. The boundaries of the spatial field do not block the flow through the zone" (Ching 2007:103-105).

## depressed base plane

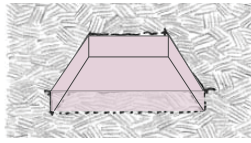

The lowered portion of the base plane creates an isolated area. "This lowered spatial zone is distinctly different from its surrounding context. The vertical elements formed by the depression creates visible boundaries" (Ching 2007:112-117).

## elevated base plane

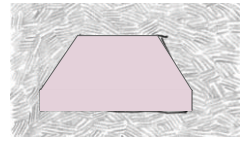

"An elevated portion with the base plane and delineates a specific territory. The level change defines the boundaries of the spatial zone and interrupts the spatial flow. The boundaries can be accentuated by means of colour of material change. This separates the spatial zone from its surroundings" (Ching 2007: 106-111).



Silva, by Fernando Caruncho (1997).  
Madrid, Spain. (Suet 2012)



Moses bridge, by RO&AD (2010).  
Halsteren, The Netherlands. (RO&AD 2010)



Dymaxion Sleep, by Jane Hutton & Adrian Blackwell (2009-2012). Quebec, Canada.  
(Hutton & Blackwell 2009)

## overhead plane

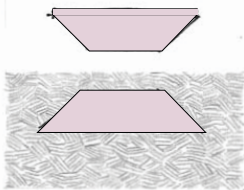

"A plane that establishes a spatial zone through the invisible boundaries created by its edges. The formal qualities of the spatial zone is determined by the height, shape and size of the overhead plane" (Ching 2007: 118-123).

## hard space:



Pergola of the Deserter, by Reudi Baur (2009). Cologne, Germany. (Bild 2009)

## pergola

## pavilion



Serpentine Gallery Pavilion '09, by SAANA (2009). London, England. (Baan 2009)

## soft space:

## canopy



Littman Kulturprojekte, by Renate Buser (2008). Basel, Switzerland.  
(Littman Kulturprojekte 2008)

## umbrella



The Umbrellas, by Christo & Jean-Claude (1984-1991). Japan & USA.  
(Volz 1991)

## vegetation

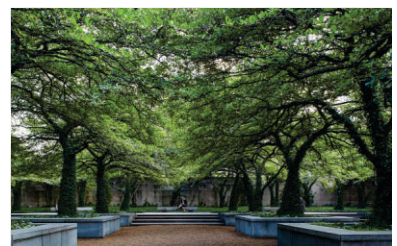

The Art Institute of Chicago South Garden, by Dan Kiley (1967). Chicago, USA.  
(Harris [S.a.])

## vertical elements

### vertical linear

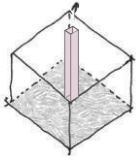

"A vertical linear element... establishes a point on the ground plane and makes it visible in space. Standing upright and alone, a slender linear element is non-directional except for the path that would lead us to its position in space. Any number of horizontal axes can be made to pass through it" (Ching 2007:126).



Geyserville Residence, by Andrea Cochran (2012). Geyserville, USA

(Brenner 2012)

### single plane

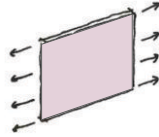

"A vertical plane has frontal qualities. Its two surfaces or faces front on and establish the edges of two separate and distinct spatial fields... The plane by itself can establish only a single edge of the field (of space). To define a three-dimensional volume of space, the plane must interact with other elements of form" (Ching 2007:134).



Eagle at SA Eagle Plaza, by GREENinc (2001). Johannesburg, South Africa

(GREENinc 2011)

### triangular configuration



"The triangle signifies stability. When resting on one of its sides, the triangle is an extremely stable figure. When tipped to stand on one of its vertices, however, it can either be balanced in a precarious state of equilibrium or be unstable and tend to fall over to one of its sides" (Ching 2007:40).



Shin-Yatsushiro Monument, by Kumiko Inui (2004). Yatsushiro, Japan (Kivinen 2008)

## enclosing elements

### parallel configuration

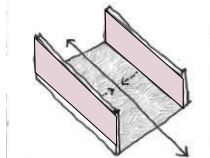

"A pair of parallel vertical planes defines a field of space between them. The open ends of the field, established by the vertical edges of the planes, give the space a strong directional quality. Its primary orientation is along the axis about which the planes are symmetrical. Since the parallel planes do not meet to form corners and fully enclose the field, the space is extroverted in nature" (Ching 2007:134).



Pavilions Parc des Rives, by Localarchitecture (2007). Yverdon-les-Bains, Switzerland

(Localarchitecture 2007)

### free-form

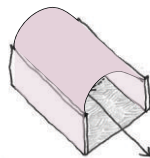

Similar to the parallel configuration, the free-form enclosing structure has fluid qualities in terms of spatial definition. In the landscape, this is commonly found in groves. "The fluid quality of curved surfaces contrasts with the angular nature of rectilinear forms and are appropriate for describing...nonloadbearing elements of enclosure" (Ching 2007:43).



Trellis at Marula Game Ranch, by GREENinc (2015). Windhoek, Namibia

(GREENinc 2015)

### four planes

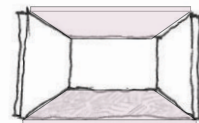

"Four vertical planes encompassing a field of space is...certainly the strongest type of spatial definition in architecture. Since the field is completely enclosed, its space is naturally inverted... Well-defined, enclosed fields of space can be found in architecture at various scales, from a large urban square, to a courtyard or atrium space..." (Ching 2007:156).



The Birdhide, by CMAI Architects (2007). Thesen Islands, South Africa.

(CMAI Architects [S.a.])





Figure 13: Sample 2 (Author 2016)

mostly lacking in this sample. It will thus have only space-defining characteristics on the overhead plane, either creating space or acting as a threshold, and not act as a shading element.

As a response, a thicker yarn was used to create the sample 2. Flat polyethylene braided ski rope created a sample of only 0.08 m<sup>2</sup>. The sample was untidy in appearance and unravelled easily due to the texture of the rope (see figure 13). However, it can have robust qualities on ground plane due to its thickness, as illustrated in figure 17. It is also sturdy enough to act as a vertical plane element, and is relatively opaque, creating a stronger edge when used as vertical space-definer.



Figure 14: Sample 3 (Author 2016)

Sample 3 was made using jute braided rope, which was thinner than the yarn used for sample 2, but thicker than sample 1 (see figure 14). It also had better gripping qualities, making it more sturdy than sample 1 but more transparent than sample 2. It lets light through, creating pattern not only as a spatial element, but also by the shadows cast when used on an overhead plane. The opportunity of this sample is that it can be used as an overhead element that acts as a threshold.

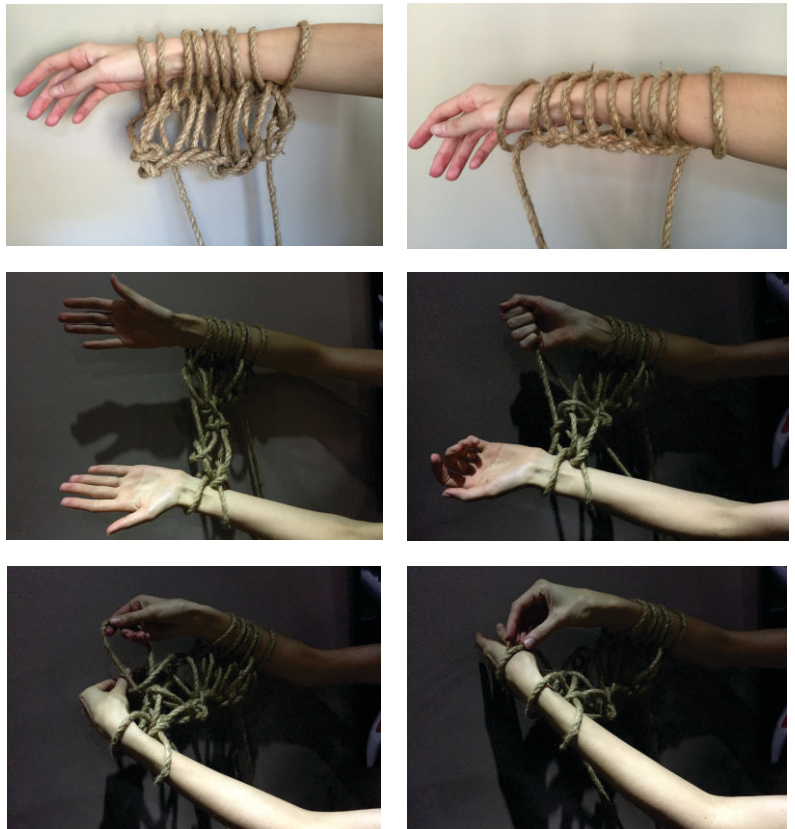

Figure 15: The arm-knitting process (Author 2016)

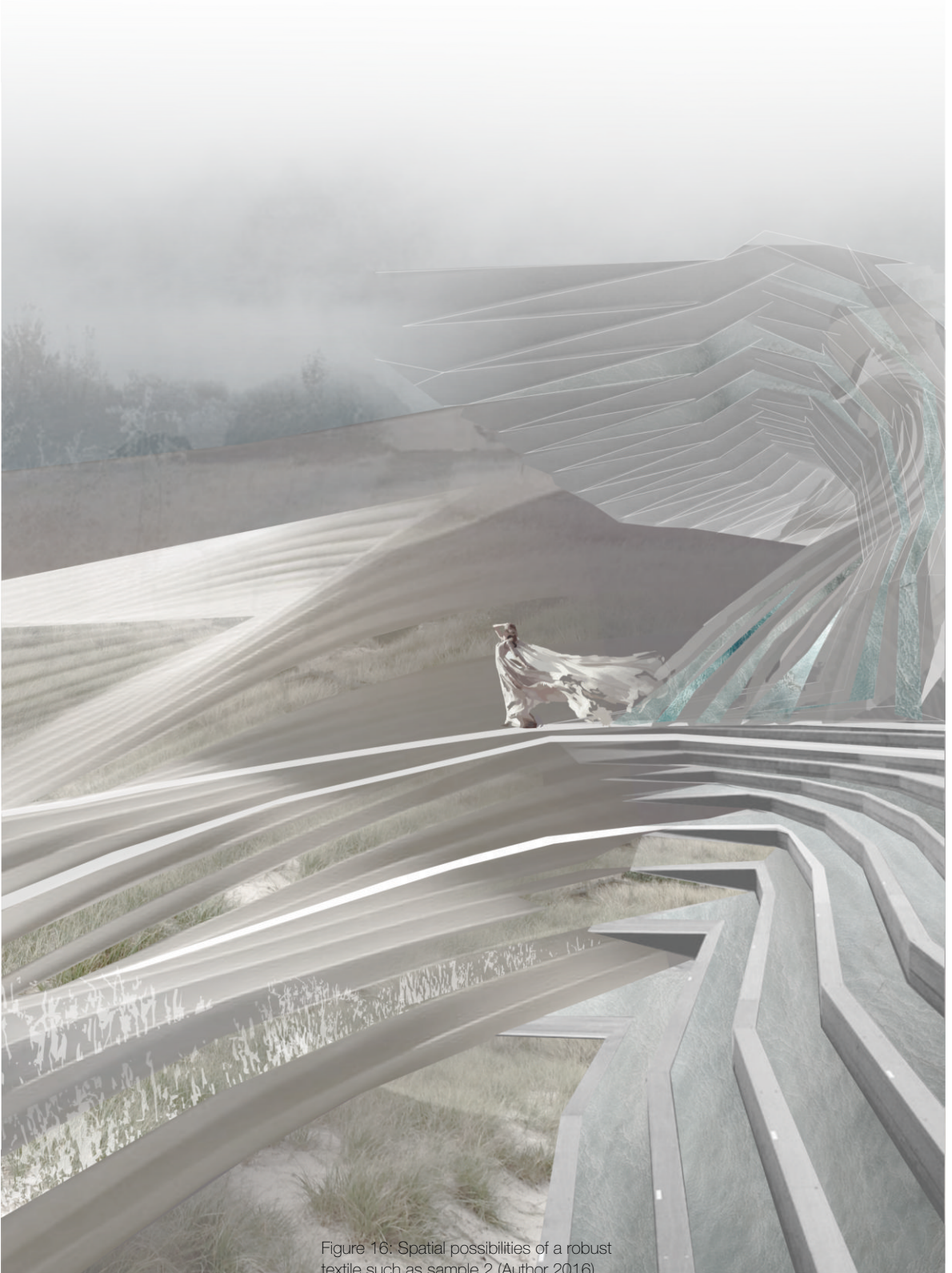

Figure 16: Spatial possibilities of a robust textile such as sample 2 (Author 2016)





Figure 17: Spatial possibilities of sample 3  
(Author 2016)



#### 4.3 Reflection and revised plan-of-action

The *causa materialis* was evident in all three samples, where the knitting process, and thus construction method of the artefact itself, was made visible through scale and repetition. The *causa formalis* of textiles differs depending on the yarn used: malleable and soft, or rigid and stiff. Thirdly, the *causa finalis* of the samples differed depending on the yarn used.

An overhead planar element implies a three-dimensional space underneath it, whereas a vertical plane implies only a single edge of a field, and not a three-dimensional space (refer to figure 12). Due to the planar qualities of the samples created, a more suitable programme for the next round of investigations is the canopy, which will be functional (providing shade) as well as spatial (implying three-dimensional space).

*causa finalis*: shade-providing canopy

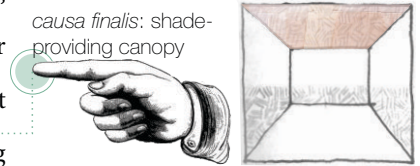

The conclusion of the knitting experiments was that knitting required a large amount of yarn to create a sample. The next phase of investigations will focus on determining a more relevant way to create space with textiles.

eliminated: knitting as *causa materialis*



What form do you want to have, textile?  
What programme do you want to be?

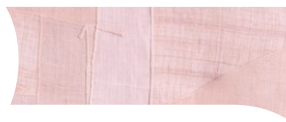

Depending on my composition, I can be malleable and soft, or rigid and stiff. I do well as a shade element.





# Phase 2: textile manipulation 5

## Knowing through folding

### 5.1 The art of fabric manipulation

Phase 1 led to the conclusion that another method of creating a shade-providing textile canopy needs to be considered. If creating textile from rope or yarn is inefficient in terms of the spatial effect achieved, perhaps the manipulation of existing textiles into unique artefacts that act as spatial elements should be considered.

Lise (2006:43) describes textile folding as a tool of fabric manipulation in garment construction: “A fold in the material sense is to give space (pleat, gather), give shape by folding away space (darting), or to make an edge (hemming). Fundamentally, the fold is a spatial entity...”

*causa formalis: folded*

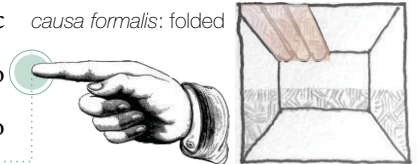

Folding thus transforms textiles from a flat surface into a spatial one. This method has potential in landscape architecture to elevate the use of textiles from functional membranes to ones that perform both functionally and spatially. Consequently, textile manipulation, as opposed to textile creation, was the focus of the next phase of investigations.

Folding of a large textile surface can be accomplished using a simple paper-based mould and pressure or heat. The moulds are folded by hand into the desired shape, after which a textile is placed in between two sheets of identical paper or cardboard layers. Pressure and/ or heat is then applied to transfer the shape onto the textile. This is a method used by fashion designers that manipulate textiles into folding and pleating, such as Issey Miyake.

### 5.2 Process of discovery: folding

Samples 1 to 4 were created to explore textile canopy folds. As sample 4 was made, an additional possibility of this method was discovered: the folds have inherent containment potential. Can these act as spaces where plants can be contained?

*causa finalis: plant-containing canopy*



Samples 5 to 14 were constructed based on which folding pattern would be best suited to creating folded textile plant pockets (see appendix B). As each sample was folded and analysed, the investigation became more focused on creating pockets with openings in the pattern in order for the plants to be viewed from below.



After exploring the possibilities of folding with paper, the patterns were transferred to textiles. The pattern used for sample 5 was successfully tested on geotextile, which is commonly used in the landscape. However, the author wondered whether the sample's aesthetic could be improved by using a different textile. Geotextiles are designed and manufactured to be mostly invisible when applied to a landscape such as eroded soil embankments, or to contain plants in a green wall. The purpose of this investigation was to explore the spatial- and aesthetic potential of textiles, along with their performance abilities. Thus other textiles, not often used in landscape applications, were tested for their abilities to be folded and to contain plants, while providing visual interest.



Synthetic fibre-based textiles were qualitatively assessed, and the samples proved to be too supple. It was also noted that their appearance was not contextual. Consequently, a quintessentially South African textile, the *shweshwe* fabric, was tested to determine whether it will be more suitable for this application. It is printed on calico, a plain-woven textile made from unbleached and often not fully processed cotton. *Shweshwe* is stiff and printed with brightly-coloured patterns, and is well-recognised in the highveld region as worn by traditional Sotho women (see figure 8a). It responded well to being folded and heat-pressed due to its stiff nature (see figure 18b). On a qualitative assessment level this textile is able to perform the function of containing plants in folded pockets, as well as creating visual interest, grounded in regional materials.



Figure 18a: Sotho woman wearing *shweshwe* (HelenOnline 2014)

Figure 18b: Folded *shweshwe* (Author 2016)

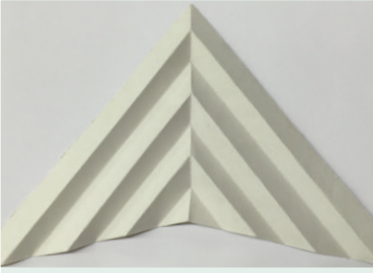

sample 5



sample 6



sample 7

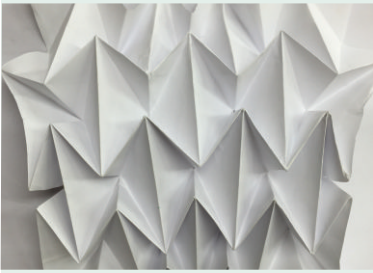

sample 8

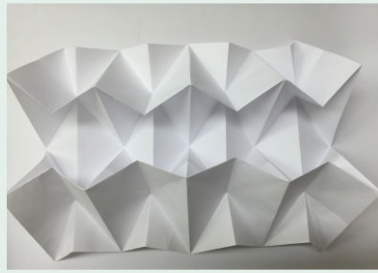

sample 10

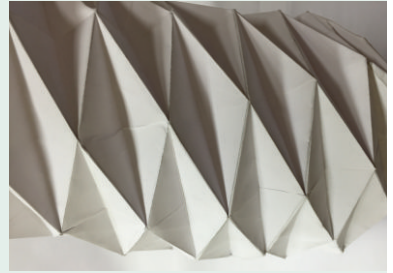

sample 11

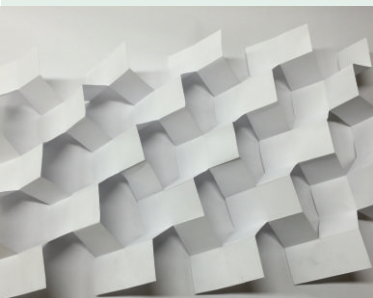

sample 12



sample 13



sample 14

Figure 19: Selected folding samples  
(Author 2016)





### 5.3 Reflection and revised plan of action

Folding not only creates opportunity to contain plants, but also to incorporate irrigation pipes as reinforcing for the mountain folds.

immersive experience



A canopy of textile-based plant pockets has the potential to create shade and an immersive experience in an environment where these functions are required immediately, or where plants are unable to grow on the ground plane. Examples of this include exhibition-like applications, or instant urban upliftment and street ‘parklets’.

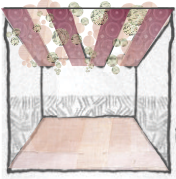

*causa finalis*: instant landscape



However, in this preliminary stage of investigation, the answer to the exact pattern of folding was still lacking, as a folded sheet that can contain plants whilst having openings in order for the plants to be viewed from below hadn't yet been established. Cutting away pieces of textile to form gaps would affect the inherent structural integrity of the overall sheet. At the risk of dwelling on the problem too long given the limited time frame for each phase of investigations, Phase 3 will explore the application of this textile-based artefact in the landscape. If this is successful, the technicalities of the folding pattern will be investigated in another phase.

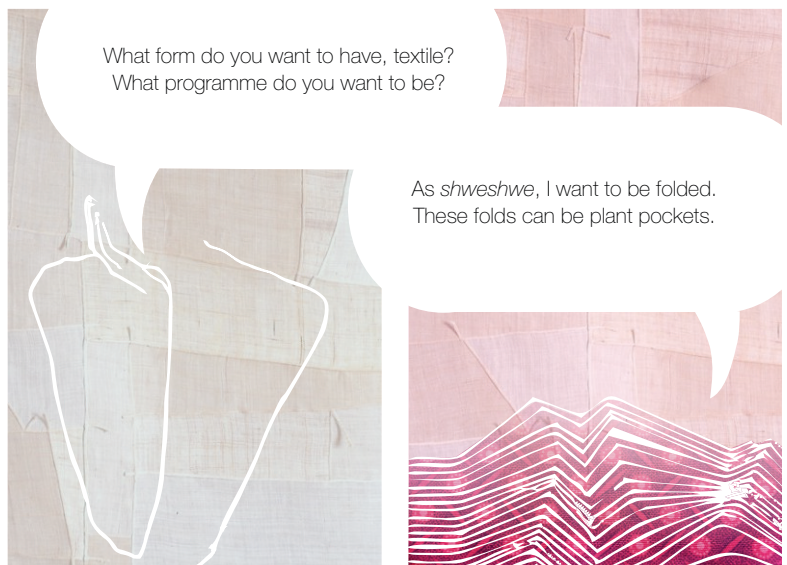



Figure 20: Conceptual vision of a planted canopy as an immersive experience (Author 2016)



UNIVERSITEIT VAN PRETORIA  
UNIVERSITY OF PRETORIA  
YUNIBESITHI YA PRETORIA



# Pavilions

# 6

## Exploring the relevance of a planted canopy as part of a pavilion structure

### 6.1 The pavilion: a testing vessel and curatorial object

This section explores the history of landscape structures in order to uncover its relevance in contemporary landscape architecture. During Phase 2, it was determined that textiles have the ability to contain plants in folded pockets as a canopy element. In addition, the application of such a planted canopy were mentioned: urban upliftment elements and ‘parklets’ are two such possibilities. What follows is a discussion on the current thinking behind the design of public space.

These ideas change as cities and lifestyles change. New ways in which to enjoy open space are required as these spaces become smaller and fewer in number due to urbanisation (Gaventa 2006:155). The result is that more imaginative, unusual types of public space are created. The instant results that some of these spaces can achieve have a large appeal, as master plans, public consultations, funding applications and appeals can be costly and time-consuming (Gaventa 2006:161). As important and relevant as conventional landscape architectural interventions are, there is a need for instant upliftment and regeneration of open space, not only in the public realm, but also in the corporate and private realm.

These spaces include the temporary, transient, mobile and flexible. They are reminders that the built environment is always dynamic and prone to be readapted and reimagined. To create a great variety of urban landscapes “we have to become more flexible in how we view and define public space” (Gaventa 2006:159). Moore (2013) states that “at their best they use temporary pleasures to make permanent changes to the way people can inhabit their neighbourhoods.”

Can the planted textile canopy be part of this new realm of thinking behind public space and what landscape architecture could be?

Built structures have formed part of gardens since antiquity. They are as much part of designed landscapes as planting and paving. This section delves into the history of garden structures to remind one of the intrinsic relationship between landscape and enclosed elements within it. It also attempts to uncover the possibilities of applying a textile canopy to a built structure.

The earliest known gardens were constructed in Mesopotamia about 6000 years ago, providing functions such as food production, and, as economic stability increased, leisure provision and the physical manifestation of ideas concerning spirituality, the universe and power (Gharipour 2013). This tradition continued into the first Persian Empire (550-330 b.c.e.) in the form of isolated gardens and courtyards, taking on a variety of layouts with different functions and design elements. Intended as an independent retreat, these were usually based on a square or rectangular plan, and included elements conducive to a pleasant environment, such as shade trees, water features and pavilions (Gharipour 2013).

Gharipour (2013) states that Persian garden pavilions were designed in order to create a built structure (building, gazebo or tent) in a natural setting for social recreation such as gatherings, parties and official meetings. The size of the pavilions was based on the proportion of the garden. Temporary and moveable structures were often transformed into permanent dwellings; at other times fixed structures were replaced by temporary ones. The degrees of enclosure depended on the primary function of the pavilion: public structures were exposed, whereas private garden pavilions were enclosed to create a suitable environment for personal leisure and recreation (Gharipour 2013). Ibn Luyun, a 14<sup>th</sup> century agronomist and poet, described the layout of pavilions in his treatise on villas, agriculture and gardening as follows:



Figure 21: Examples of gazebos and garden buildings (Author 2016)

In the centre of the garden let there be a pavilion in which to sit,  
and with vistas on all sides... (it) should be longer than it is wide in  
order that the beholder's gaze might expand in its contemplation (in Hunt 2012:66).

The use of pavilions in garden design expanded from the Middle East to North Africa, subcontinental India, Western Europe and the East Asia. Pavilion structures include gazebos, buildings and tents.

### 6.2.1 Gazebos

Gazebos are small garden pavilions that are open on all sides, and include kiosks, alhambras, belvederes, follies, pergolas, and rotundas (see figure 21). Kiosks were popular in Persian garden design, often being the starting point of water channels that divided quadrilateral gardens into smaller parts, based on the Charbagh arrangement of Mughal Empire era gardens (1526-857) (Plumptre 1989:7). Gazebos in China served the simple purpose of allowing observation of the surrounding landscape, especially popular during the Tang Dynasty (618-907). Pavilions were placed in parks such that “a great variety of scenes” may be experienced (Samson 2015:34).



### 6.2.2 Buildings

Garden buildings provide shelter from the elements, act as focal points in garden layouts, and are destinations to walk to from the main residence at country estates. Dovecots and temples featured in English Picturesque gardens, often occupying key positions and directing the eye to vistas (Plumptre 1989:45) (see figure 21). The Japanese *chashitsu* (tea house) were free-standing structures dedicated to tea ceremonies. They first appeared during the early Edo period (*ca.* 1600), and were found in the gardens of private homes, temples, museums or parks (Plumptre 1989:34).



### 6.2.3 Tents

Fabric structures are some of the oldest forms of architecture. The traditional tent consists of a frame and a cover, allowing a user to quickly construct a protective covering against the elements (Krüger 2009:142). Tents have evolved since 28 000 b.c.e.. from being a basic sheltering element of Nomadic peoples to serving military purposes (as seen in a relief showing an Assyrian tent from the army camp of Sennacherib (705-681 b.c.e.) and housing festive gatherings (such as the audience and marriage



Figure 22: Examples of tent structures  
(Author 2016)

tent of Alexander the Great (256-323 b.c.e.) (Krüger 2009:143).

Persian tent construction methods, developed after the onset of the Ottoman Empire (1290-1923) reached Greece during the Persian Wars, influencing Greek theatre construction and Roman festival tent typologies (Krüger 2009:143). In the late eighteenth century, garden tents became a staple in European folly gardens. Extant examples of these include the Tartar Tent at the Parc Monceau in Paris, France (1775) (see figure 22), and the Vakttälet at Drottningholm Palace in Stockholm, Sweden (1781).

The beginning of the nineteenth century saw an increase in middle-class leisurely activities in Europe and the USA, the traveling circus being one of them (Krüger 2009:143). During the 1950s, Frei Otto's ground-breaking research on tensile structures made possible the transfer of membrane construction concepts to large structures (Krüger 2009:144).

Some may question the validity of free-standing structures and their place in typical landscape architecture. However, the typology is still relevant, and can be found in the phenomenon of the contemporary pavilion.

### 6.3 Contemporary pavilions

#### 6.3.1 Emergence and functions

At the beginning of the 21<sup>st</sup> century, pioneering architectural design ideas and concepts were presented at world design fairs, intended to be temporary structures. Contemporary European pavilions are still designed as mostly temporary structures, but have since the 21<sup>st</sup> century expanded into public space, such as in urban squares and parks, as well as semi-private spaces like art galleries and museums (Stern 2015).

Etymologically the word pavilion derives from the old French *papillon* or *papilio* in Latin which both translate to butterfly. This implies "lightness, random movement and temporality" (Stern 2015).

Pavilions are generally commissioned to be a program-less space. They are an "art exhibit and a curatorial object" that make architecture approachable and communicative (Stern 2015). The pavilion as typology suggests interaction, communality and participation, and as such it inevitably offers a high degree of experimentation and innovation. It fluctuates between a building and an experiment, between the speculative and the pragmatic (Stern 2015).



Placing pavilions in the public realm is more relevant for cultural advancement, as it appears as a temporary agent in the city, and as such, suggests “establishing a new order within the surrounding built environment” (Stern 2015). These objects in the urban realm act as a 1:1 scale prototype, allowing designers to test their ideas on an actual human scale and receive the user's feedback instantaneously. It offers constant accessibility and a continuous discourse with its users, who are invited to capitalise the space, inhabit it or pass through. The users, who are typically the city explorers (the *flâneur*), occupy the space randomly and by their diverse arbitrary movements, reorder the space, as a self-organising system, and create unpredictable spatial configuration as well as multiple social interactions (Stern 2015).



Pavilions have had many different functions since their origins during the Persian Empire. They can be spaces for contemplation or gathering. They can provide shade, shelter or seating. Pavilions can also be places where refreshments are served, where goods are sold, items displayed or ideas tested.

The Serpentine Gallery, situated in Kensington Gardens in London, has been commissioning the building of temporary summer pavilions on the lawn in front of the gallery since 2000 (Gaventa 2006:169). Each year (except 2004) a different leading international architect has designed a structure that acts as a café and space for events, as well as a piece of sculpture and a visitor attraction (see figure 23). The pavilions stay in place for three months, each year attracting an additional 200 000 visitors to the Serpentine within six weeks of their opening (Gaventa 2006:169).

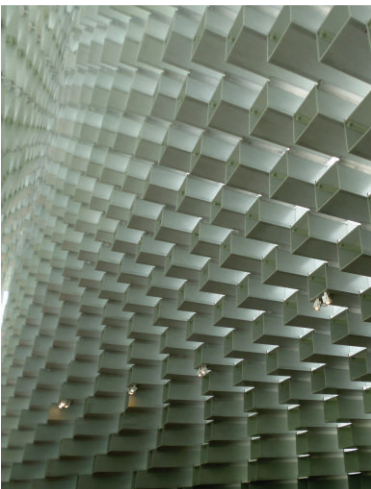

### 6.3.2. Typology

The predominant contemporary pavilion typology is one of ephemerality and a high degree of permeability; therefore the articulation and the tectonics of the envelope are defining features of the space's experiential effects, as well as of the object's uniqueness. Perforations, as an integral component of the enclosure, are essential for light penetration, but even more so, for communication amongst users, which allow a continuous flow

Figure 23: 2016 Serpentine Gallery Pavilion, by BIG. London, England (Author 2016)

between internal and external spaces (Stern 2015).

Rotundas, certain kiosks and bandstands, which were popular in Victorian parks, are point elements, projected vertically into a linear form, such as a cylinder (see figure 24). Belvederes are generally situated at higher points in the landscape in order to provide ideal viewing opportunities. In this case, the route to the top informs the spatial layout. Some gazebos are linear elements with strong horizontal defining planes, punctuated with columns that allow permeability for optimal views to the landscape (see figure 25). Thus, pavilions range in form from enclosed buildings to simple overhead elements.

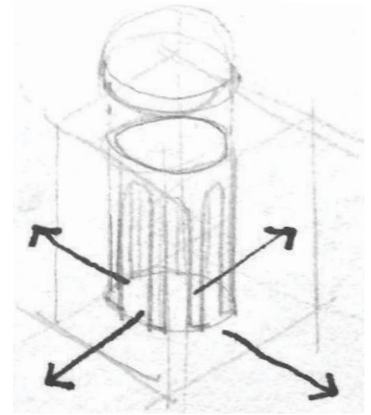

Figure 24: Vertical linear spatial layout of typical rotundas (Author 2016)

#### 6.4 Pavilion structures in Pretoria

Pavilion structures in Pretoria are uncommon, despite the potential benefits that they would provide to the capital city inhabitants and visitors alike, such as shade and seating. Prominent pavilions in Pretoria include the rotundas in Burgers Park and West Park, the latter being a band-stand structure surrounded by an amphitheatre. In the center of the park is a small pavilion with a refreshment kiosk, which was a typical feature of parks about a century ago.

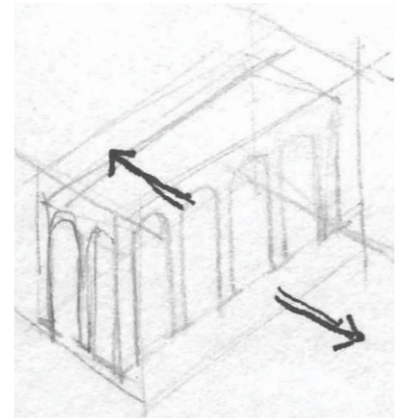

Figure 25: Vertical configuration of gazebos that require permeability (Author 2016)

The Venning Rose Park has formal post-modern entrance pergolas offering shaded walkways to a tea garden, which was closed in 2006. Clientele were lost to restaurants at the adjacent Eastwood Shopping Centre, and lack of parking facilities leads to the park being under-utilised by visitors traveling by car. The park was left in poor condition due to theft, vandalism and the vacant tea garden structure. Vacant structures is a key concern for the Department of Parks and Horticulture as this allows for illegal occupation, damage, theft and other criminal activity.

Pavilions serve to activate landscapes by having open programming. This supports the relevance of pavilions in current-day Pretoria. The ever-changing nature of cities with their variety of users can be responded to by means of pavilions that can be customised based on the context: through a kit-of-parts.

kit-of-parts pavilion



## 6.5 Programming the pavilion

number of users 

length of use 

Use and user

slope 

surface material 

solar exposure 

water availability 

Existing site conditions

shade 

shelter 

seating 

plants 

lighting 

Requirements

If the textile plant-containing canopy is applied in the landscape by means of a kit-of-parts pavilion structure, different combinations of the canopy can result in a variety of site-specific conformations, supporting and further strengthening its relevance.

The programming of the kit-of-parts pavilion in Pretoria will depend on the user and the type of site where it will be assembled. Informal trade and small enterprises are estimated to contribute around 28% of South Africa's gross domestic product (South African LED Network [S.a]). The pavilion can act as a stall with a counter and shade canopy where informal trade occurs (see figure 25). In areas where instant urban upliftment is needed, the pavilion can act as a gathering space, a vertical linear element that makes it “visible in space” (Ching 2007:126), or a linear street element that acts as threshold between public streetscape and private shop front. Both of these can provide seating opportunity. The planted canopy will provide a unique and immersive experience for city dwellers where greenery is lacking (see figure 26).

## 6.6 Reflection and revised plan of action

Pavilions as garden structures have formed part of landscape design since the Persian Empire. They range from simple overhead membranes such as tents to structural members supporting an overhead element, open to the landscape. Traditionally, their functions were to create shade or provide a place to rest and observe the landscape. Structures are thus as important an element in landscape design as other built features like ponds and walls. Their typology is still relevant, as can be seen in the phenomenon of the contemporary pavilion.

In addition to the traditional function, contemporary pavilions are also designed and constructed to test ideas and new technology. Importantly, they are often placed in public spaces, and are an essential part of the ongoing development of, and innovation in, the field of landscape architecture.

Figure 24: Determining the kit-of-parts (Author 2016)



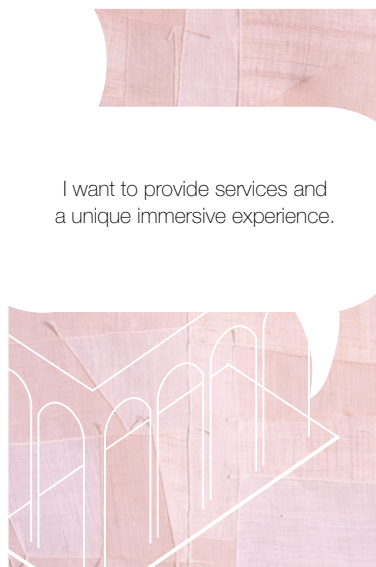

Figure 25: Informal trade in Pretoria (Author 2012)

Figure 26: Instant landscapes installed by communities or private individuals (Author 2016)



What role do you want to play in Pretoria, pavilion?



I want to provide services and a unique immersive experience.



Figure 27: Types of intervention sites (Author 2016)

# Phase 3: The application of the 7 canopy as part of a pavilion

## Knowing through modeling

### 7.1 Textile canopy

#### 7.1.1 Modelling techniques

The first step during the conceptual design phase was to apply folded textile pockets onto a canopy structure. As mentioned in section 4.4 a singular sheet of paper or textile can't easily be shaped into both pockets and openings, based on existing folding patterns. Discoveries based on hand-folding are very valuable to assess the spatial potential of each, however it is a time-consuming method if in-depth studies are required. This led to computer-aided modelling as a tool to assess the appearance of folded canopy elements when applied at different scales and in different conformations. The notion of computer modeling goes against the initial discussion regarding making by hand. Can it be used to supplement hand-making, and play a supporting role during the investigation process?

Parametric design is a mathematically-driven technique where real-world parameters such as light and stress forces are entered into a digital script. The design outcome changes based on the parameters, and this is often used in architecture to design solar facades. Initially, this tool was used because of the need to model different versions of the canopy based on the qualities of space uncovered during the hand-folding process. However, it illustrated the value of technology when combined with hand-making methods.

Even though more time is spent developing the script than on folding paper, any variable that the user changes will be shown in the model without having to rewrite the entire definition. Thus many more iterations can be generated once the script is written. Inputs such as the number and size of folds, as well as the spatial conformation, allowed the generation of canopy designs and the visualisation of their characteristics along with

computer-aided modeling to supplement hand-making



The hand discovers what a material wants to be, and the computer repeats these possibilities.

their shading-and containment properties.

### 7.1.2 Design logic

Because this phase makes use of computer software to model design ideas, the resulting designs are not considered to be samples, as in phases 1 and 2. They are instead referred to as iterations (refer to figure 27).

Iteration 1 focused on a folding pattern without openings. Instead, the way in which plants could be viewed was based on its spatial conformation, changing as the user moves underneath the canopy. Despite its possibilities, openings in the pattern were desired, not only to experience the plant canopy, but also to create visually appealing shadow patterns. In this way the interest can be both on the overhead plane as well as on the ground plane.

Similarly to phase 2, no established folding pattern was used. Instead, an idealised version of the canopy was modelled, with an interplay between folded textile plant-containing pockets, and openings in the pattern in order to view and experience the plants. Iteration 2 combined folded textile pockets along with openings applied on a flat overhead plane. Further variations of this definition investigated curved planes, contorted in three dimensions, to reveal the plants from different angles. A more elegant geometry was required, and thus the curved surfaces needed to be simplified.

Due to the multiplicity of functions desired, the canopy should be separate from the pavilion structure and be able to be used in different scenarios. During phase 2 a hypar paper structure was folded (sample 4), but its potential as a plant-containing element was dismissed due to the nature of the folds. However, the logic of the structure itself showed potential: as a lightweight frame onto which irrigation pipes can be attached, which, in turn, act as a structure onto which the folded textile pockets can be suspended by their mountain folds. The canopy can act as a free-standing structure, as well as be suspended from a larger structural frame. This was the motive behind the form of the hypar, and when modelled digitally, it displayed an elegance in its aesthetic.



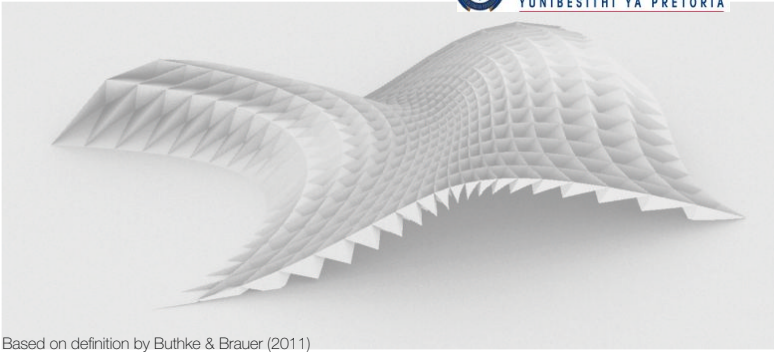

Based on definition by Buthke & Brauer (2011)  
Iteration 1: folded pockets

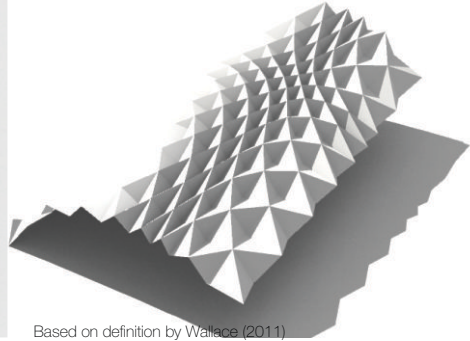

Based on definition by Wallace (2011)

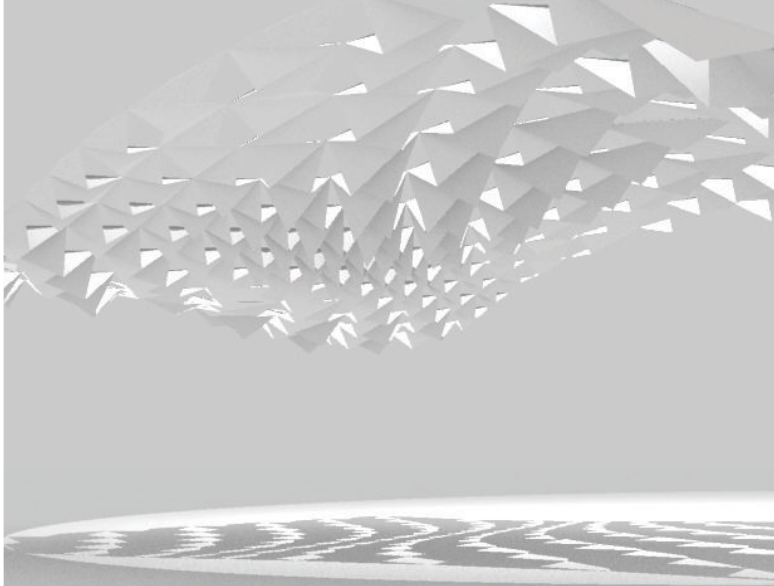

Iteration 3



Iteration 2

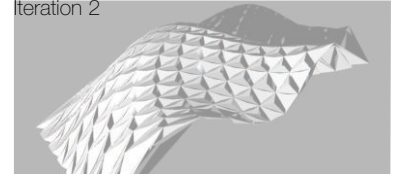

Iteration 3

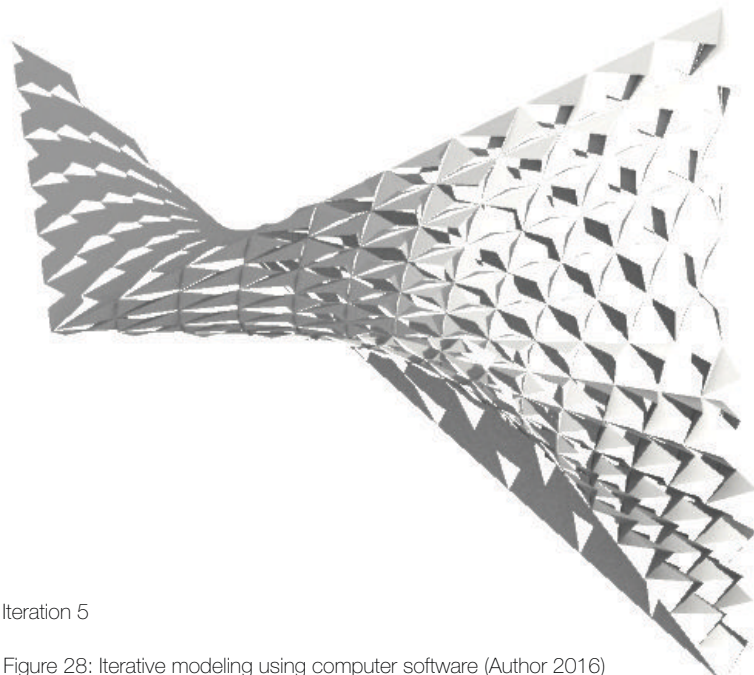

Iteration 5



Iteration 4

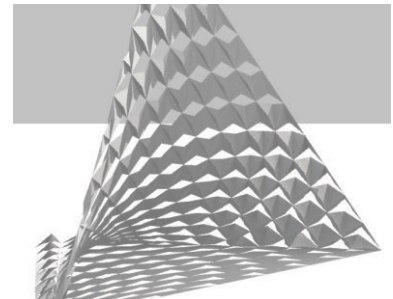

Figure 28: Iterative modeling using computer software (Author 2016)

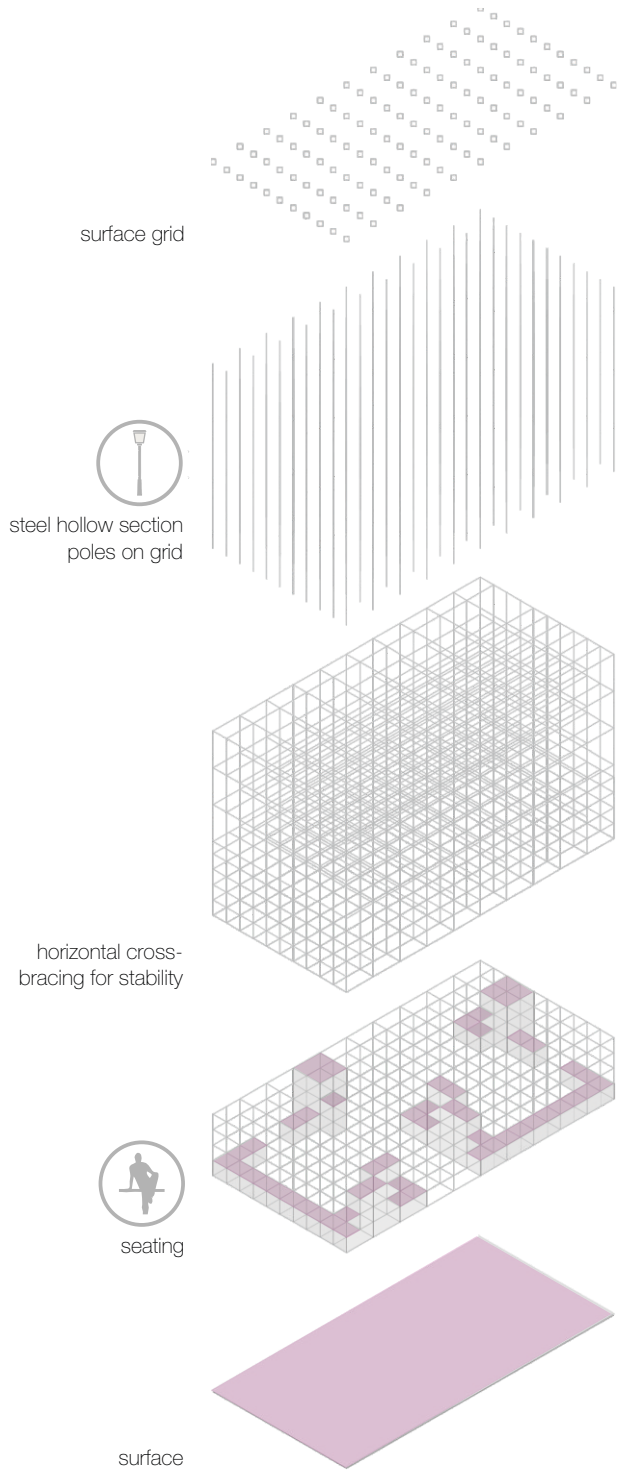
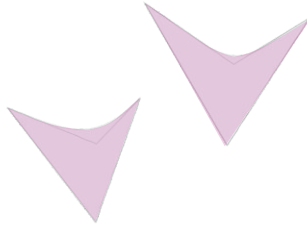

Figure 29: Pavilion composition (Author 2016) (continued on following page)



textile canopies



points of entry  
cut out of structure

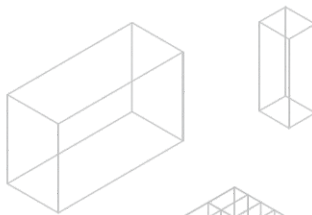

volume subtraction

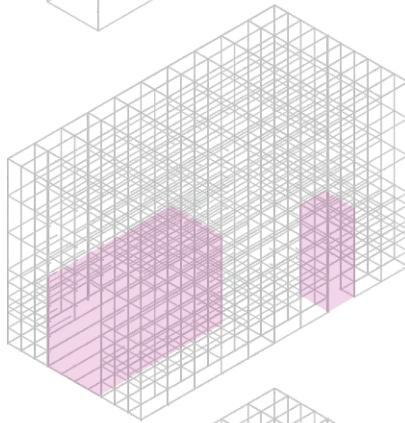

resulting structure

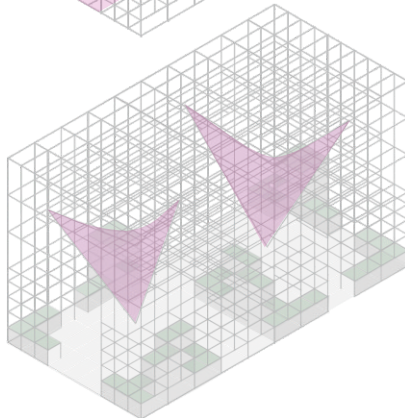

Conceptually, the structure was based on a grid, out of which programmatic spaces were subtracted (see figure 28). This was modelled parametrically, based on the dimensions required by seating and walking. The canopy was then suspended on the structure, further subtracting from the frame's conceptual grid. The value of modelling the structure in this way was in quickly generating a series of responses based on the parameter of dimensions, incorporating circulation as well as seating into the structure. The opportunities of working with a structural grid also presented themselves in the form of lighting design. Vertical non-structural members can also act as luminaires, either between the canopy and the main structural frame, or as vertical members below the canopy structure. Figures 30-36 illustrate further explorations of the pavilion.

### 7.3 Reflection

During this phase of investigations, there was an interplay between digital modelling and physical model-building. A physical scale model was built based on the digital model in order to determine the essence of the design and acted like a *parti* drawing (figure 29). It helped to simplify the conceptual design, and to determine further spatial possibilities by acting as a tangible object that was responded to by critics, examiners and fellow students. Parametric design assisted in generating quick responses, and model-building was useful on a conceptual design level.

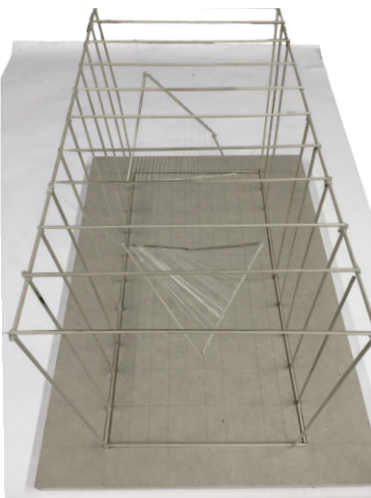
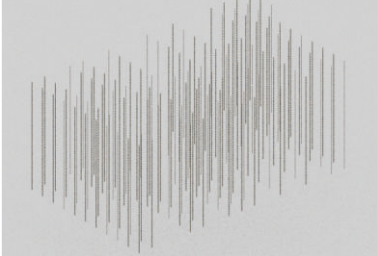

Figure 30: Conceptual model acting as a *parti* diagram (Author 2016)

New possibilities discovered during phase 3 include the value of parametric modelling, and the possibilities of the hyper as structural frame. The next phase in the design of the pavilion is the generation of different spatial possibilities of the pavilion in order to choose the most successful one that can be taken further on a technical level.





suspension units for plants

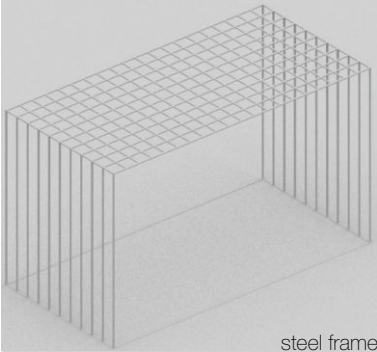

steel frame

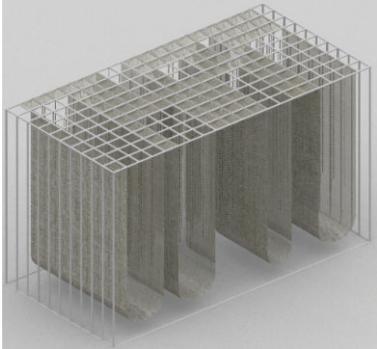

Figure 31: Textile pavilion as provider of immersive experience (Author 2016)



Figure 32: Pavilion as provider of immersive experience (Author 2016)

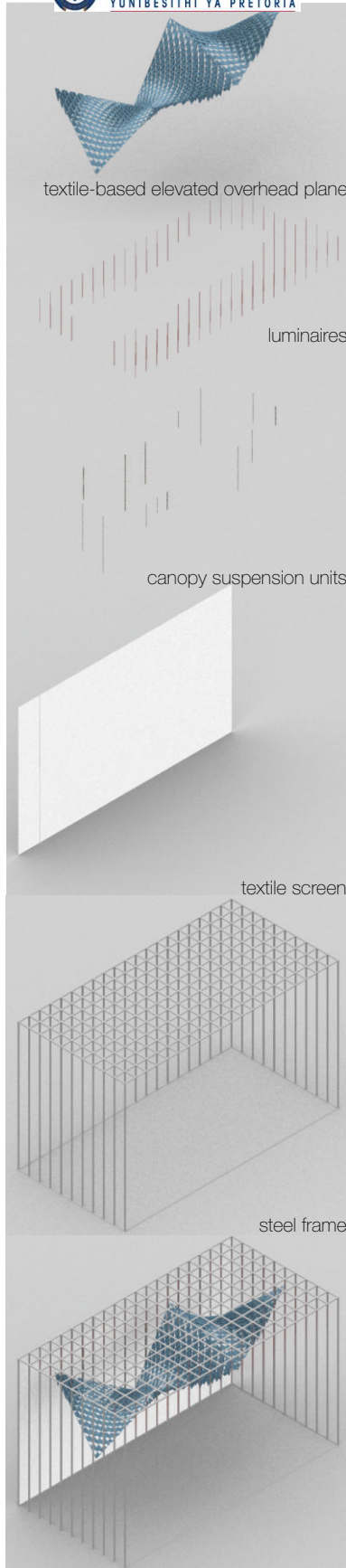

Figure 33: Pavilion as provider of services (Author 2016)



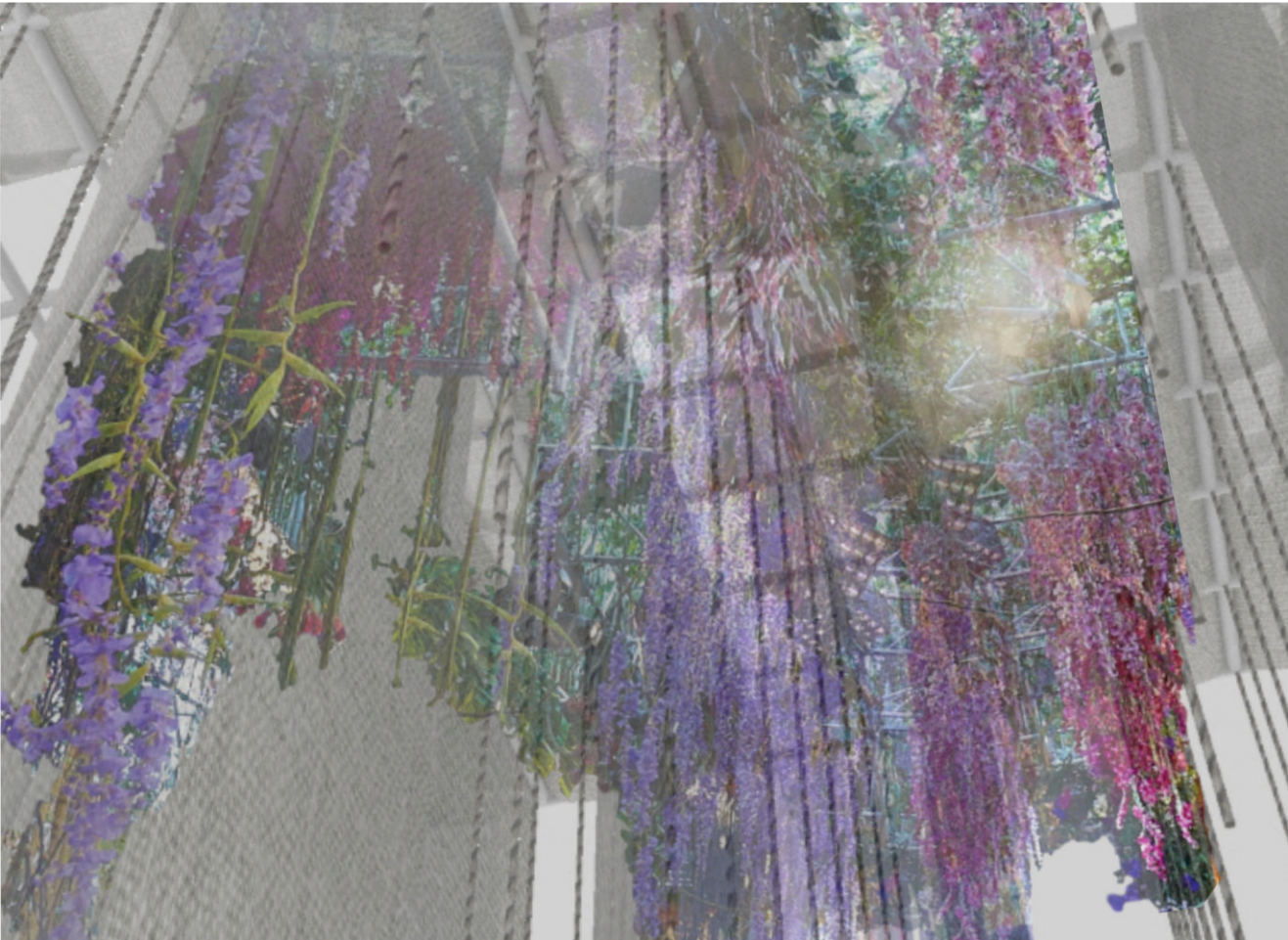

Figure 34: Immersive experience with plants and textiles (Author 2016)



Figure 35: An elevated textile base plane adding to a unique user experience (Author 2016)



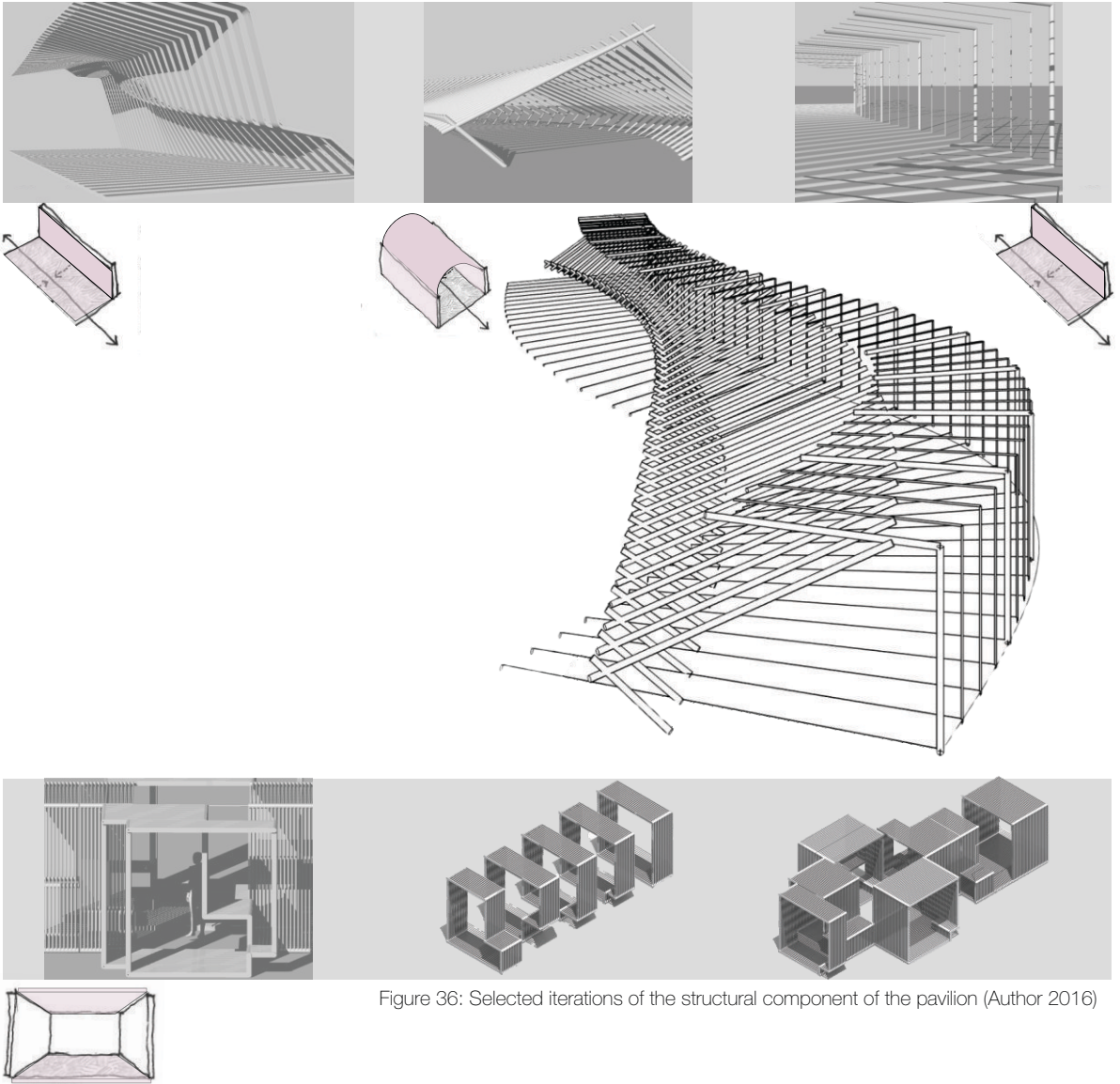

Figure 36: Selected iterations of the structural component of the pavilion (Author 2016)



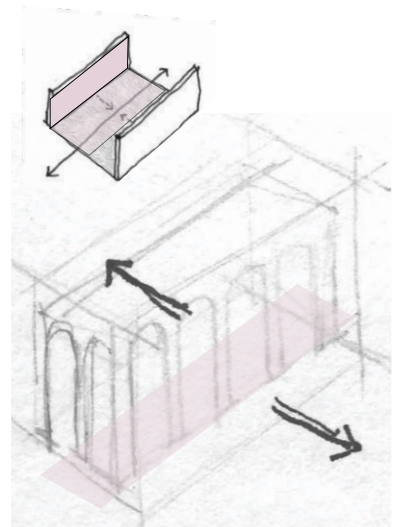
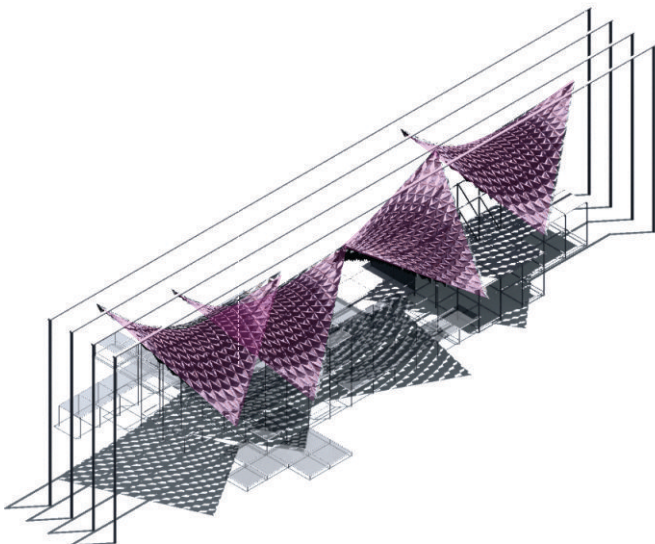
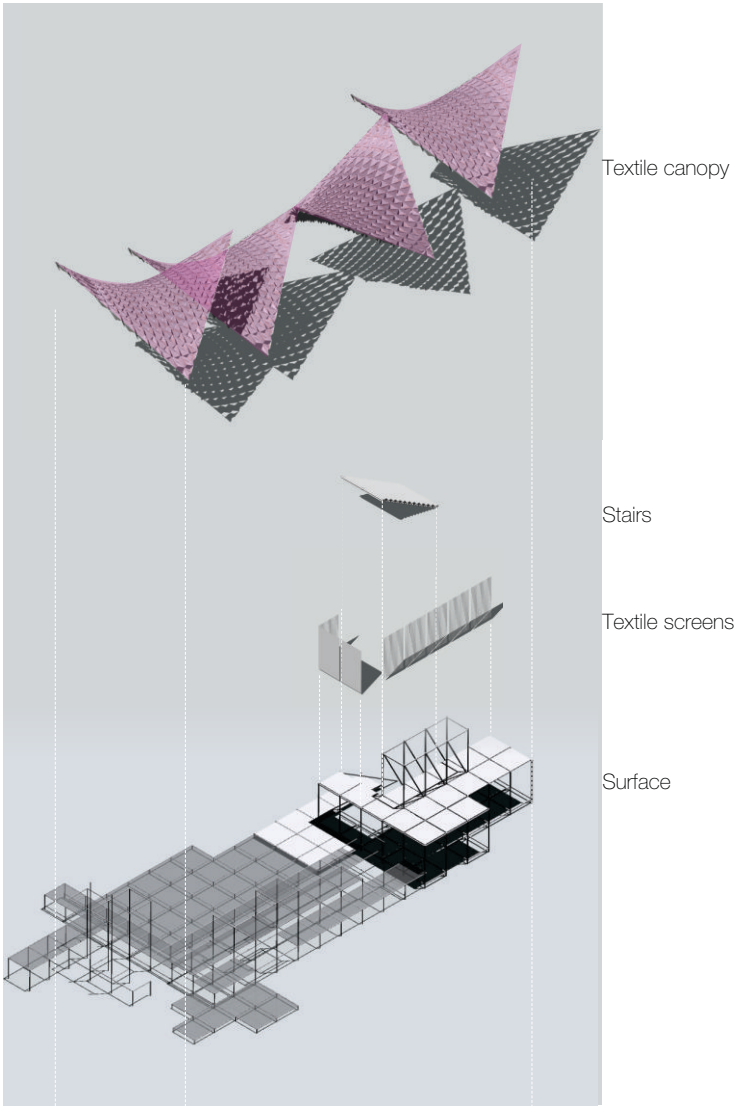

Figure 37: Linear pavilion acting as threshold and gathering space (Author 2016)



UNIVERSITEIT VAN PRETORIA  
UNIVERSITY OF PRETORIA  
YUNIBESITHI YA PRETORIA

# The making of the pavilion

# 8

## General design and construction considerations

### 8.1 Introduction

Landscape architectural interventions that are instant and mobile have the ability to breathe new life into city spaces, and assist parks to reprogramme their use and draw new users. The design of these temporary and mobile structures has to take into account their transport, assembly and disassembly, along with their use and programme. Another important consideration is their afterlife, which should be planned with thought. Environmental consciousness is an aspect of contemporary design that ought to be integrated, to an extent, into every project undertaken. Thus, to avoid contributing to the issues created by consumerism-driven design, one should address what will happen to the structure after being dismantled.

The fate of a selection of pavilions constructed in 2015 was determined by Winston (2016), who found that 46% (thirteen) were relocated and 36% (ten) were recycled. One pavilion was made permanent, and the fate of 14% (four) was yet to be determined, being kept in storage until a decision is made (Winston 2016) (see table 1).

This quick overview of the fate of only a handful of temporary pavilions indicates that the majority of structures are utilised after their original objective has been reached. 82% of these were disassembled and either relocated or the parts re-used for other purposes, which makes designing for quick assembly and disassembly important for easy handling and transport.

Furthermore, in order for the pavilion to have a longer lifespan in a rapidly-changing environment, it must be multifunctional and easily adaptable to different site conditions. However, this must also be restricted in order to avoid acontextuality.

These aspects further improve the quality of constructed spaces.

Relocated	Recycled	Undetermined	Remained
Serpentine Gallery Pavilion by SelgasCano	ICD Aggregate Pavilion 2015	Camera Obscura by Mariano Dallago	Shiver House by NEON
Circular Pavilion by Encore Heureux	Eigen Huis & Interieur pavilion by i29	New Horizons Red Pavilion by TAKA, Clancy Moore Architects and Steve Larkin Architects	
Oasis Pavilion for APMAP by OBBA	Around Pavilion by Christiansen and Andersen		
Kiosque pavilions by Ronan and Erwan Bouroullec	Ka300 Pavilion by J Mayer H	France Pavilion for Milan Expo by XTU Architects	
Mpavilion by Amanda Levete	The Temple by Kingston University students	Walden Raft by Elise Morin and Florent Albinet	
Glaze pavilion by Cousins & Cousins	Governor's Island pavilions by Bang Studio and Chinchilla Architects		
Brazil Pavilion for Milan Expo by Studio Arthur Casas and Atelier Marko Brajovic	The ETH Future Pavilion by ETH Zurich		
China Pavilion for Milan Expo by Studio Link-Arc	Pulp Pavilion by Ball-Nogues Studio		
The Hive, Britain Pavilion for Milan Expo, by Wolfgang Buttress and BDP	Breathe, Austria Pavilion for Milan Expo by Klaus K Loenhart and the Breathe team		
UAE Pavilion for Milan Expo by Foster + Partners	Toronto Winter Stations 2015		
COSMO pavilion for MoMA PS1 by Andrés Jaque and Office for Political Innovation			
The Original Dwelling by Atelier van Lieshout			
Yure pavilion by Kengo Kuma			

Table 1: The fate of 28 pavilions erected in 2015 (Winston 2016)

According to Ryan (2011) creating landscapes that are robust relies on the ease of construction. This is accomplished by specifying detailing and materials that are easy to assemble, forgiving and resource-efficient. Ease of assembly is achieved with parts that are easy to handle and connections that are accessible. Forgiving details allow for adjustable fit during assembly. Resource efficiency considers using off-the-shelf parts that are easy to replace and recycle or re-use, as well as taking into account the transport from factory to site.

## 8.2 Textile pockets

The shortcomings of using a folding pattern to generate a three-dimensional textile canopy that can contain plants, as well as have openings in the pattern for the plants to provide an immersive experience for the user, were encountered in phases 2 and 3.

What followed is the testing of a singular folded textile planting pocket module that can be repeated and applied throughout the canopy. Figure 37 illustrates the resulting origami folding pattern that produces a textile module with four similar pockets. It has the potential to contain plants, and, if no plants are required by the client, it can easily be manipulated mechanically to form a closed canopy if more shade is required. This was tested on a 1:1 scale, using *shweshwe* for the textile body and metal wire for the mountain fold reinforcing. Combining several of these modules proved to be possible by simple joining techniques (in the case of the prototype the metal wires were joined together by bending the ends into hoops), while the opening and closing of the textile canopy was further enabled because of the stiffness of the metal wire.

## 8.3 Structure

Temporary or instant urban space interventions require easy assembly and disassembly, as well as off-the-shelf materials that are easily replaceable. A modular structural system such as scaffolding can be adapted to different site- and slope conditions. The following precedents illustrate the use of scaffolding in spatial design.

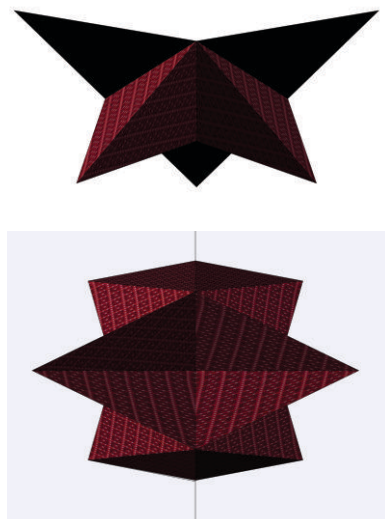

Figure 38: Textile plant pocket module as viewed from below (Author 2016)



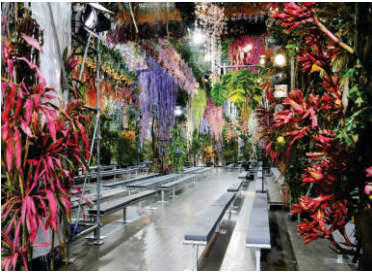

Figure 39: Dior Spring/Summer 2014 collection set design (Tododesign 2014)

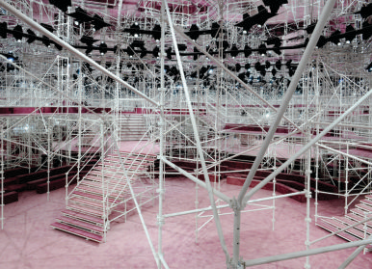

Figure 40: Dior Spring/Summer 2015 collection set design (Dirand 2015)



Figure 41: Dior Fall/Winter 2015/2016 collection set design (Dior 2015)



Figure 42: Louisiana Hamlet Pavilion, by Selgascano (Selgascano 2015)

Raf Simons has experience in fashion design, furniture design and fine art curation. During his role as Creative Director of Christian Dior, he was also responsible for designing the sets where Dior's couture collections were displayed. These often consisted of simple scaffolding, either used in isolation, or in conjunction with elements such as glass and flowers, where he worked in conjunction with set designers Bureau Betak.

The Dior Spring/Summer 2014 collection was presented in the gardens of the Musée Rodin in Paris. Scaffolding created the formwork of the set, entitled *Paradise on Earth*, which was adorned with an abundance of roses, lilies and tropical fluorescent flowers (figure 38). The flowers and foliage were artificially created with fine, dyed silk, creating a canopy of cascading fabric plants.

The Dior Haute Couture Spring/Summer 2015 collection was presented against a backdrop maze of white scaffolding and soft carpeting (figure 39). Figure 40 illustrates how the Fall/Winter 2015/2016 collection also featured scaffolding used in a visually appealing way. Hieronymus Bosch's *Garden of Earthly Delights* (1503-1515) was the inspiration behind the set design, created in conjunction with Bureau Betak. Referencing the Adam and Eve tale of innocence and temptation, Simons' fashion vision was executed through the gaze of the Flemish and French masters of art and couture craft. Geometrical, glazed panels painted with pointillist dots were placed between the scaffold frameworks to create a structure resembling a "greenhouse-cum-church" (Israel 2015).

A pop-up building in the Louisiana Museum of Modern Art's sculpture garden, designed by José Selgas and Lucía Cano, served as a viewing space for short films as part of the 2015 exhibition called *Africa: Architecture, Culture, Identity* (Stamp 2015). The temporary structure, called the Louisiana Hamlet Pavilion (see figure 41), was designed to be disassembled after the exhibition and then shipped to Nairobi, Kenya, where it now serves as a school (Stamp 2015). It consists of colourful scaffolding components and plastic sheets to allow quick and easy assembly, disassembly and transport. These materials are commonly found,

lightweight, and easy to construct with, yet were used in an artful way.

Pavilion MMM (Miami Many-a-chair Monument) was a temporary pavilion installed at the Miami Cultural Plaza in 2014 by Design With Company (see figure 42). The design consists of chairs purchased at local yard sales, converted into swings and hung from a modular structure made of construction scaffolding members. The strategy makes assembly straightforward, economical, and appropriate based on the installation's temporary existence (Design With Company 2014).

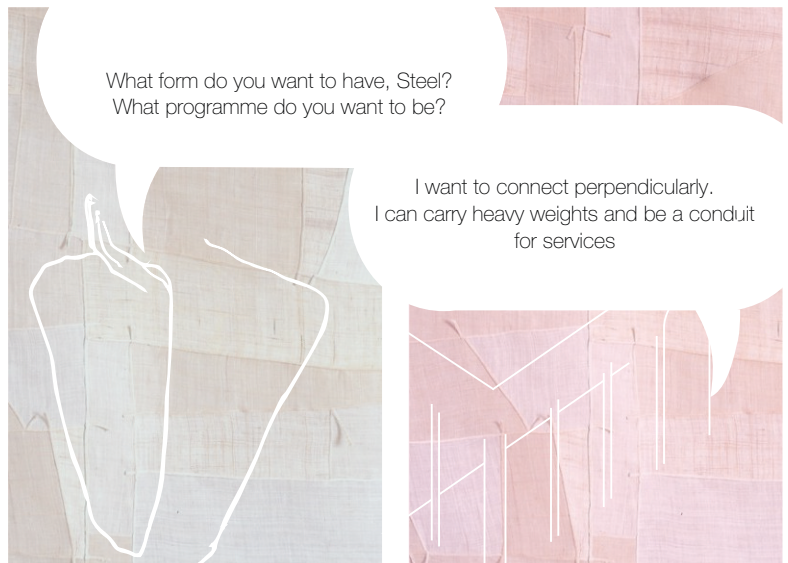

Figure 43: Pavilion MMM (Design With Company 2014)

These precedent studies show how everyday objects can be used in a visually appealing and striking manner. This is in line with the normative positions of post-modernist landscape architects, who believed that landscape architecture is an art form related to the other visual arts, and that landscapes could also serve as a cultural artefact, expressive of contemporary culture and made from modern materials (Schwartz 1993:260). Martha Schwartz states that “nonprecious materials and off-the-shelf items can be used artfully, and with this attitude we can build beautiful landscapes; not only for the rich, who today will no longer pay for fancy materials, but also for the middle class, who can't afford them” (1993:262). Schwartz has an artful approach towards the design of spaces and objects within them, by “making discreet landscape objects and shaping that landscape as an integrated artwork” (1993:262).

In addition, steel will be able to carry the loads and stresses exerted on the structure (see figure 46).

Hollow structural sections have good resistance to loads in multiple directions. Structural tubing thus wants to be columns. They will also be able to accommodate electrical cables for lighting and irrigation pipes if planting is required, further supporting the rationale behind this material choice.





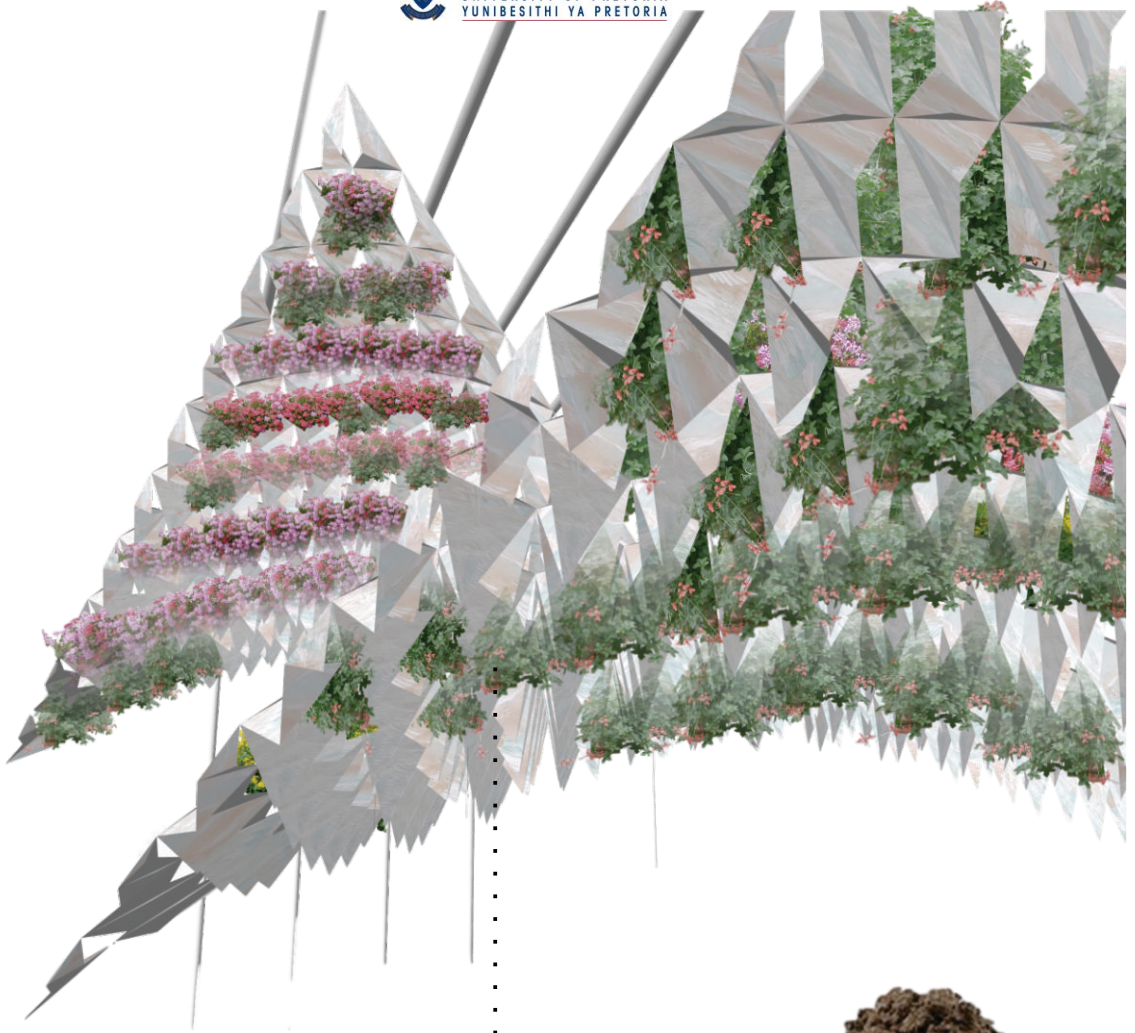

peat moss: 70%



coconut coir: 10%



perlite: 10%



limestone + wetting agent: 10%

170 kg/m<sup>3</sup>

Figure 44: Planted textile canopy (Author 2016)

Figure 45: Composition and density of PRO-MIX™ HPCC Mycorrhizae

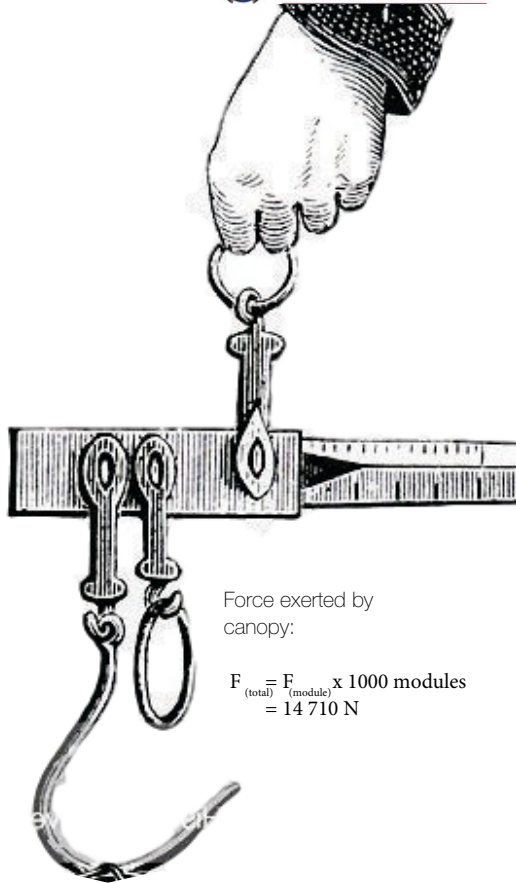

Force exerted by one module:

$$F = m \cdot a$$

$$= (1,5)(9.80665)$$

$$= 14,710 \text{ N}$$

Force exerted by canopy:

$$F_{(total)} = F_{(module)} \times 1000 \text{ modules}$$

$$= 14\,710 \text{ N}$$

$$a = 9.80665 \text{ m/s}^2$$

$$m = 1,5 \text{ kg (1 + 2 + 3)}$$

1  $m_{(textiles + wires + retained\ water)} = 0,500 \text{ kg}$

2  $m_{(plant)} = 0,150 \text{ kg/plant}$   
 $= 0,600-0,800 \text{ kg}$

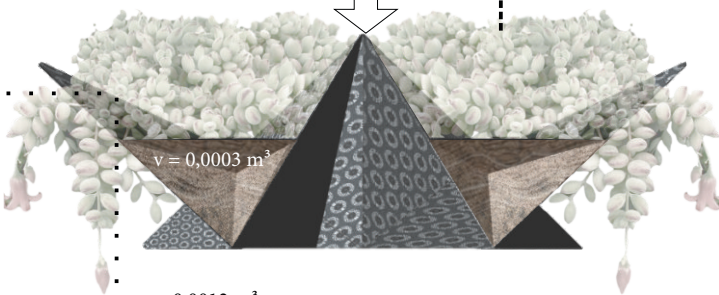

$V_{(total)} = 0,0012 \text{ m}^3$

3  $m_{(growth\ medium)} = 0,0012 \text{ m}^3 \times 170 \text{ kg/m}^3$   
 $= 0,204 \text{ kg}$

Figure 46: Forces exerted by canopy on supporting structure (Author 2016)

## 8.4 Plant selection



Figure 47: Salvatorpassage hanging plant canopy, by Herzog & De Meuron (Subtilitas 2011)

The use of plants on the overhead plane has the potential to create an immersive and atmospheric experience. The Salvatorpassage of Fünf Höfe in Munich, Germany, by Herzog & De Meuron is the centrepiece of a building complex constructed in the 1990s. It is a glass-enclosed interior space, 19m long, 10m wide and 14m high. A grid suspended under the ceiling like a canopy accommodates a variety of vines and climbing plants, forming a hanging garden up to 10m high (Herzog & De Meuron 2006). The project illustrates how plants can create an immersive user experience. Trailing and cascading plants will be able to be viewed from beneath the textile canopy.

The plant selection was based on criteria related to the site and the desired atmosphere. For canopy plants in sunny positions, its light requirement is a dominating determining factor. Furthermore, it should grow well in a container, and be drought-tolerant. The final criterion is that it must have a sprawling growth form, in order to cascade between the openings in the textile canopy and create an immersive user experience. The same applies to canopy plants that are required in semi-shade, such as in an atrium or between buildings. Refer to figure 50 for the plant palette.



Figure 48: Kimono Forest at Arashiyama Station, by Yasumichi Morita (Author Station, by Yasumichi Morita (Author 2016)

## 8.5 Lighting

Lighting features also have many possibilities of being integrated into the pavilion design. Yasumichi Morita combined textiles and lighting in a poetic and striking way with the design of an “artificial forest” at Kyoto's Arashiyama Station. Acrylic poles are draped with traditional *yuzen* dyed kimono fabrics, illuminated from within by LED lamps. This ‘kimono forest’ presents commuters with a particularly spectacular view from within trains that are pulling into the station after sunset (Wee 2013). The 2013 *Through Hollow Lands* installation at the Frye Art Museum in Seattle by Lilienthal | Zamora was made with 200 suspended fluorescent lamps (Himede 2013). The result is a striking display using a standard item.

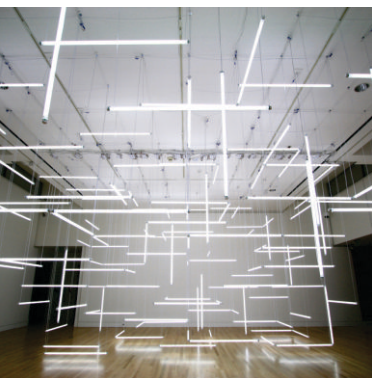

Figure 49: Through Hollow Lands installation by Lilienthal | Zamora (Lilienthal 2012)

These examples show how linear lighting elements can be a continuation of the scaffolding structure.





Matsiwe VogelPark, 2008

a

a. *Pelargonium tongaense*

The Tonga pelargonium is a free-flowering garden and container plant. It prefers light to dense shade, but can be grown in full sun as well. Its range of light tolerances and its growth habit make it a good option for an atrium textile canopy.

b. *Asparagus plumosus*

This scrambling perennial herb has tough green stems, which may reach several metres in length. The foliage is fine, soft and fern-like. Small, bell-shaped flowers occur from spring to autumn. It has a striking appearance, grows well in light to full shade and requires moderate amounts of water.



b

Figure 50 (continues on p. 74-78: Plant selection (Author 2016)



d

c. *Asparagus densiflorus*

The *Asparagus densiflorus* is a versatile and drought-tolerant plant that grows well in containers. It has trailing branches that can grow up to 1 m long, which will create a mass of green foliage year-round. It can be grown in full-sun, as well as in an atrium space with light shade.

d. *Cotyledon pendens*

This is a much-branched succulent shrublet with dense, curtain-forming, hanging stems up to 600 mm long. They thrive in hanging baskets and containers, and naturally grow in dry cliff faces, making them a good option for the canopy feature. The foliage will create year-round interest, and tubular flowers are a striking sight in winter.



Kvarnblog [S.a.]





e



f

e. *Delosperma tradescantioides*

This cliff-hanging, mat-forming plant with stems up to 1 m long forms loose curtains of foliage, making it ideal to create an immersive experience when walking under the textile canopy. It is also an excellent container plant, and withstands dry periods.

f. *Othonna capensis*

A low-growing, succulent groundcover with a spreading habit. It needs very little care and establishes itself easily in most soils, the proviso being good drainage. These characteristics make it a good choice for a full sun or partial shade textile canopy pavilion.



g

g. *Senecio angulatus*

Described as a scrambling and twining herb whose form is a dense tangled shrub 2m tall. Established plants are extremely drought tolerant. Their growth form and drought tolerance will make them well-suited for canopy planting.

h. *Pelargonium peltatum*

This semi-succulent perennial climber has long, straggling shoots, which can reach a height of 2m. It looks striking in hanging baskets and containers, and can grow in full sun or shade. This plant is drought-tolerant.



h



i. *Ceropogia woodii*

The string-of-hearts is usually kept as a hanging pot subject. The small, heart-shaped leaves are a dull pinkish purple below and either green or a variegated silvery-green above. They require light shade and are moderately drought-tolerant.





Ebur2016

j. *Senecio rowleyanus*

The string-of-pearls is a creeping, perennial, succulent vine that grows in light shade. Its leaves are the size and shape of small peas, growing on trailing stems that are up to 900 mm in length. In summer, trumpet-shaped flower forms clusters of small white flowers. It requires very infrequent watering and a few hours of direct sunlight per day, making it well-suited to an atrium receiving some direct sun.

k. *Chlorophytum comosum*

The hen-and-chickens is a perennial evergreen herb with trailing stems up to 1 m in length. It grows very well in baskets, and its ornamental, gracefully ascending-spreading to recurved leaves in a central rosette make it popular as a house plant. It prefers partial shade and moderate amounts of water.



k

JayJayc 2011

## 8.6 Textiles as display surfaces and space-definers

Textile panels can serve as vertical space-defining elements that can also be used for exhibition purposes. The 2009 Liceo Ópera exhibition in Barcelona, Spain, by Cadaval & Solà-Morales, was based on the use of simple canvas panels organised in a way that guides the visitor as well as creates a strong spatial experience (Lavinia 2009).

Figures 52 and 53 show removable textile screens made from agricultural shade netting. They can act as space-defining elements to guide users through the space, or act as screens to create more private spaces within the pavilion.



Figure 51: The use of textile panels as vertical space-defining element at the 2009 Liceo Opera House exhibition (Cadaval & Sola-Morales 2009)

## 8.7 Water

The conceptual approach to the capture of rain water for irrigation of the canopy plants is for surface runoff to be captured and stored in shallow (200mm) containers that form part of the base of the structure (see figure 54).

Preliminary water calculations were based on the general water requirements of succulent plants, but show that this approach will be feasible in the long-term (see appendix C). However, for a short-term application such as in an atrium for an exhibition or in a garden space as a temporary shade structure, there would need to be a connection to municipal water supply.

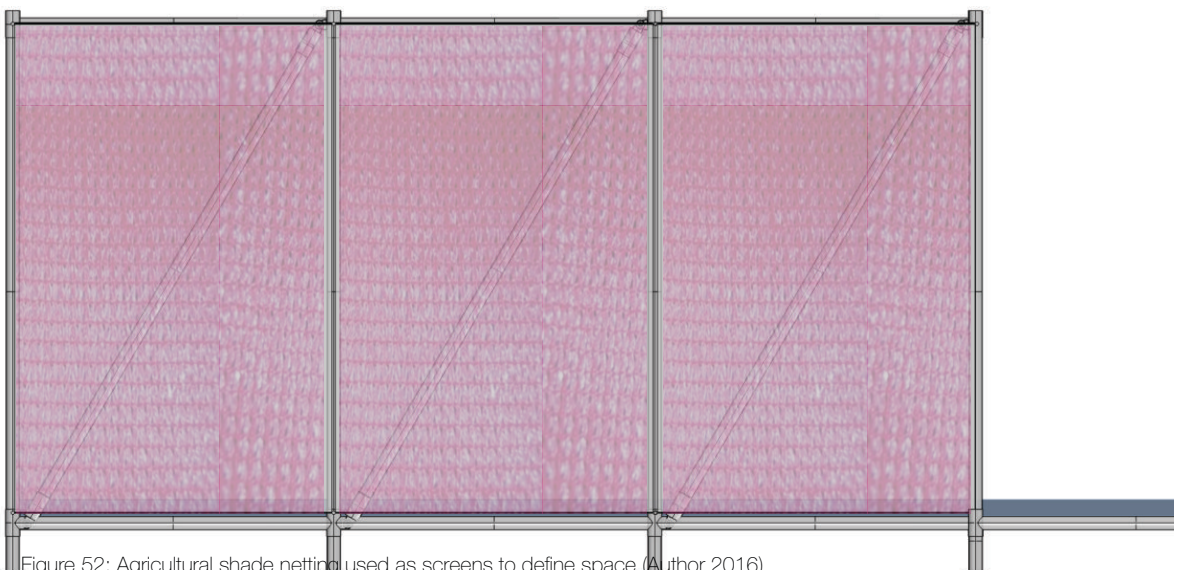

Figure 52: Agricultural shade netting used as screens to define space (Author 2016)

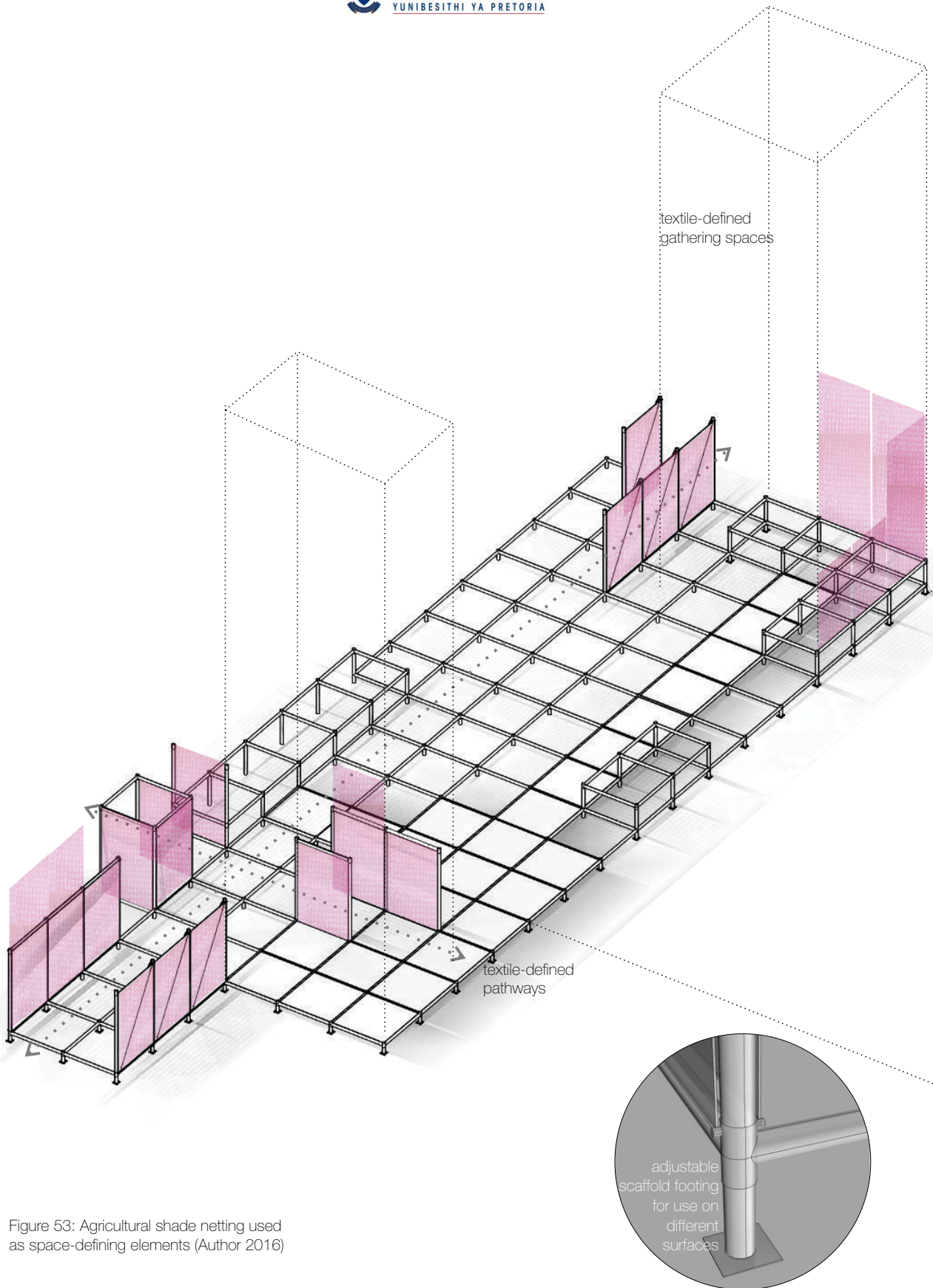
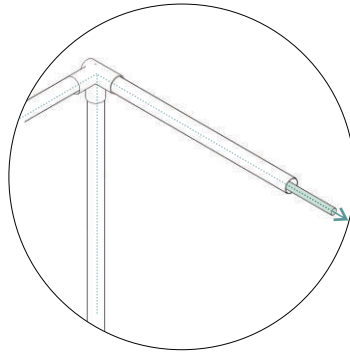

Figure 53: Agricultural shade netting used as space-defining elements (Author 2016)





Scaffold steel hollow sections act as conduits that carry irrigation pipes

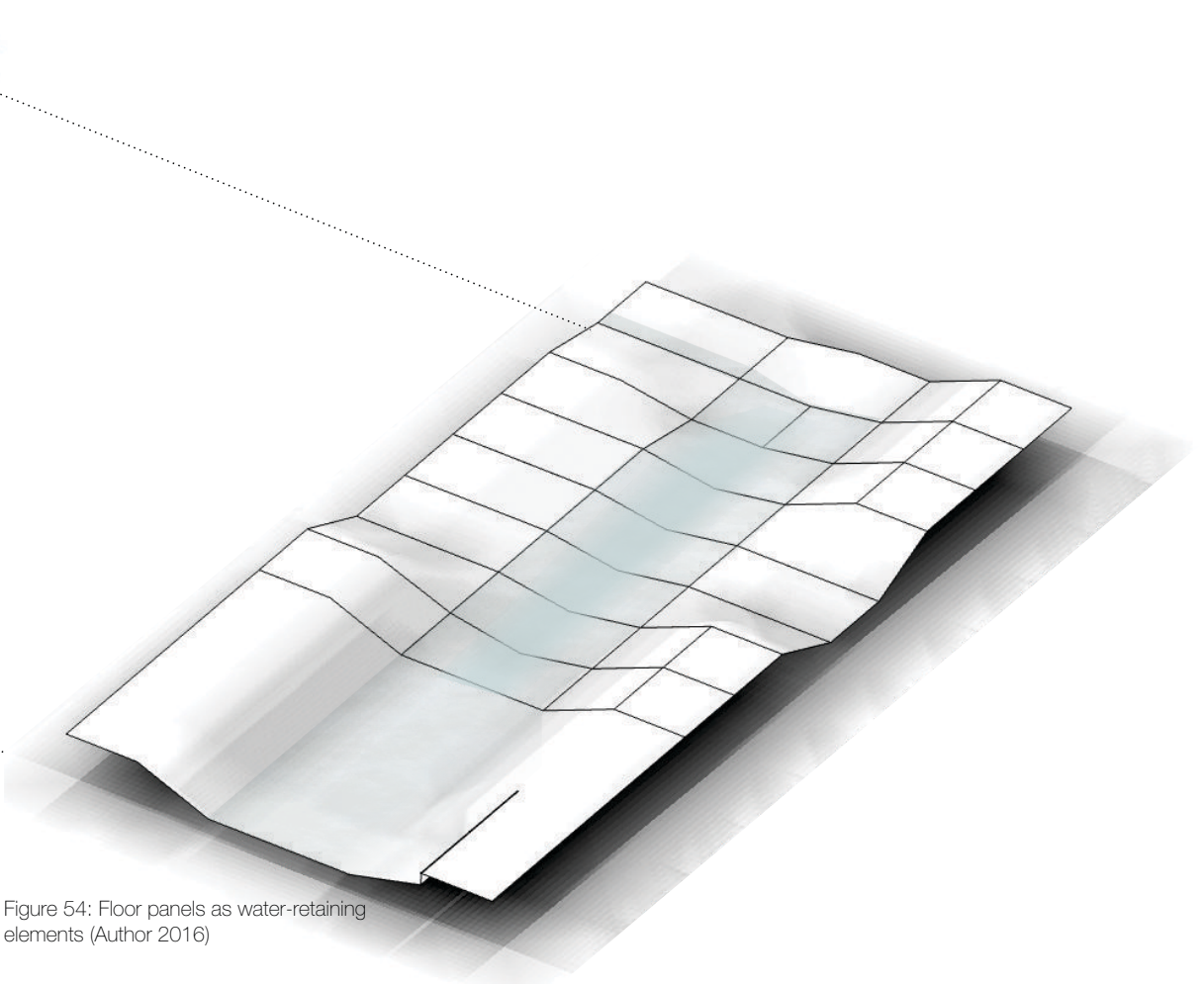

Figure 54: Floor panels as water-retaining elements (Author 2016)



### 8.8 Seating

Rope, such as mountain-climbing rope, can be simply spanned and attached to the scaffold frame and thus act as different seating elements. The different conformations depend on whether individual or social seating is required (see figures 55 and 56).

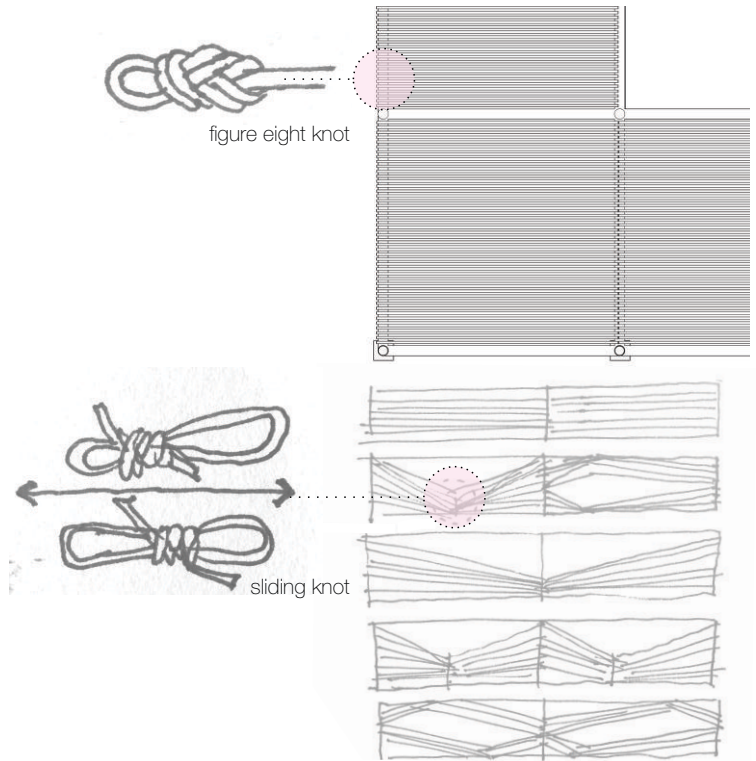

Figure 55: Seating (Author 2016)

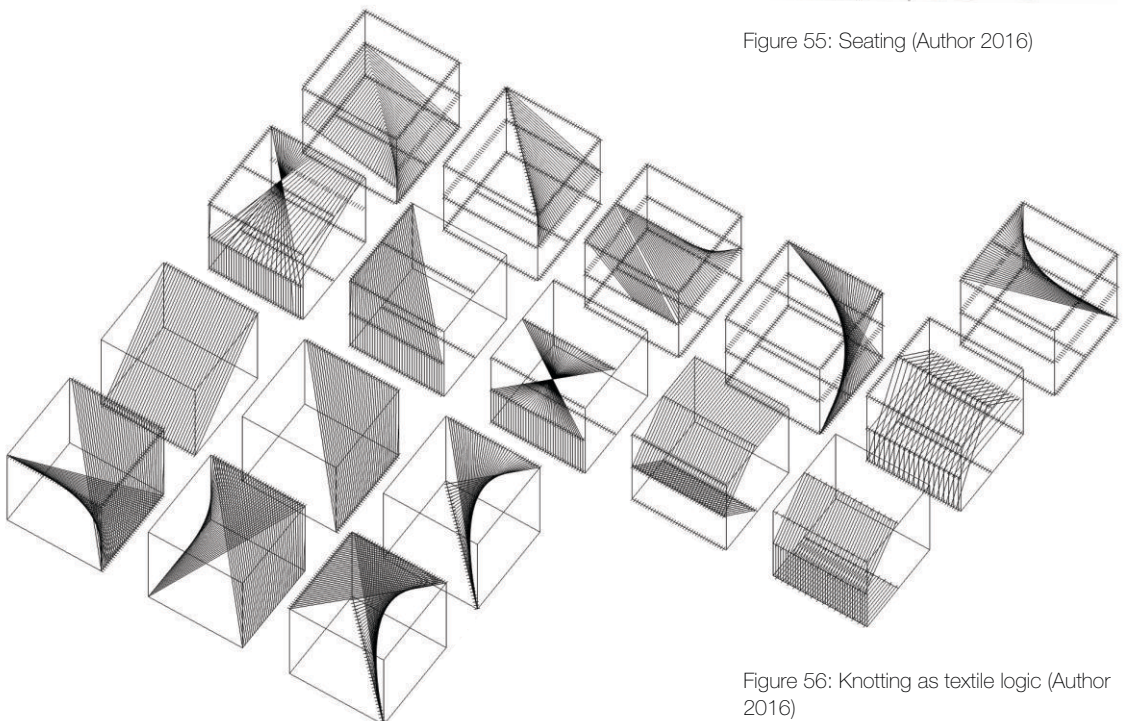

Figure 56: Knotting as textile logic (Author 2016)



## 8.9 Surface as extension of the landscape

As mentioned in Section 3.1 there is a fundamental difference between buildings and landscapes and that is the application and harvesting of elements that act upon them. Broughton (2012:9) states that “in built landscapes the process of construction is doubled”, as contingent forces constantly manipulate the designed landscape after initial construction has been completed. Where most would consider these elements to be destructive, Broughton (2012:39) claims that textiles have the ability to engage with these elements in a constructive manner: “By strategically utilising materials that can structure contingent environmental forces, landscape architects might configure these forces to work in support of their design intent” (Broughton 2012:39).

Hutton (2013:123) asserts that landscapes are unique in that biological and geological actions have an influence on how landscape architects should construct. “...it is through engagement with geological and biological action and the nonlinear yet powerful relationships between structure and formal expression where landscape tectonics finds its poetics of construction” (Hutton 2013:123) (see figure 57).

Landscapes are dynamic, and this should be harnessed to work with the designed landscape intervention, and not against it. How can the computer software used in the modeling of the pavilion extend beyond pattern and embrace the changing nature of landscapes?

Hansen (2011) states that “performance is a major factor that separates landscape architecture from architecture”, and because of this, effective parametric designs are applied on a landscape in a “performative”, as opposed to “formal” (Hansen 2011) or pattern-based way. Hansen (2011) further points out that parametric design makes visible the often invisible, which reaches its full potential in landscape architecture. “Landscape is defined by...living materials that grow, weather, and decay; and temporal cycles that span hours, days, seasons, and epochs.” These ephemera can be understood, manipulated or emphasised by parametric design.

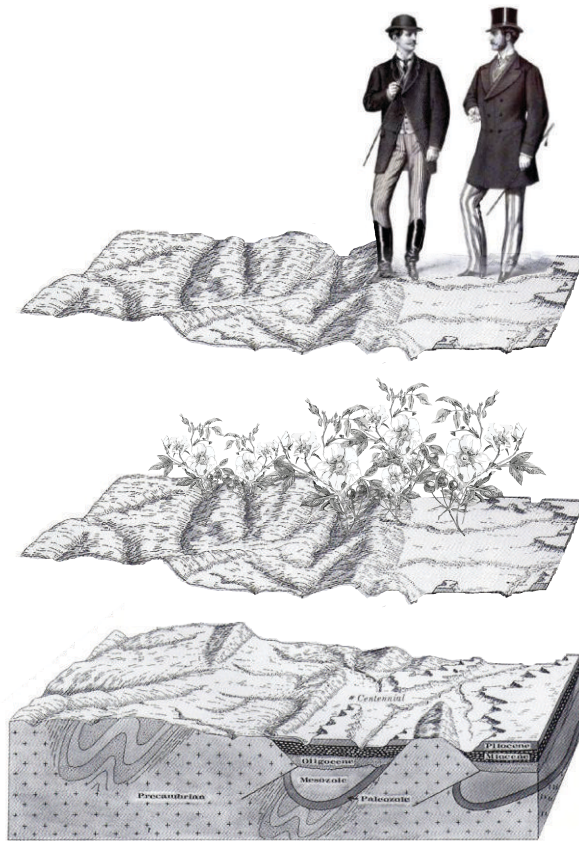

Figure 57: Biological, physical and anthropological forces acting on the landscape (collage by Author 2016)

If the pavilion is permanent, these landscape forces can be made visible. To create openings for plants to established on the ground plane, their size and growth habit can be used as parameters to determine the size of the openings in the surface panels. Seeds embedded within the composite material will germinate after enough water is received, and will grow over time as a visible element of invisible forces: natural (rain and sun), biological (plant growth) and anthropological (human intervention).

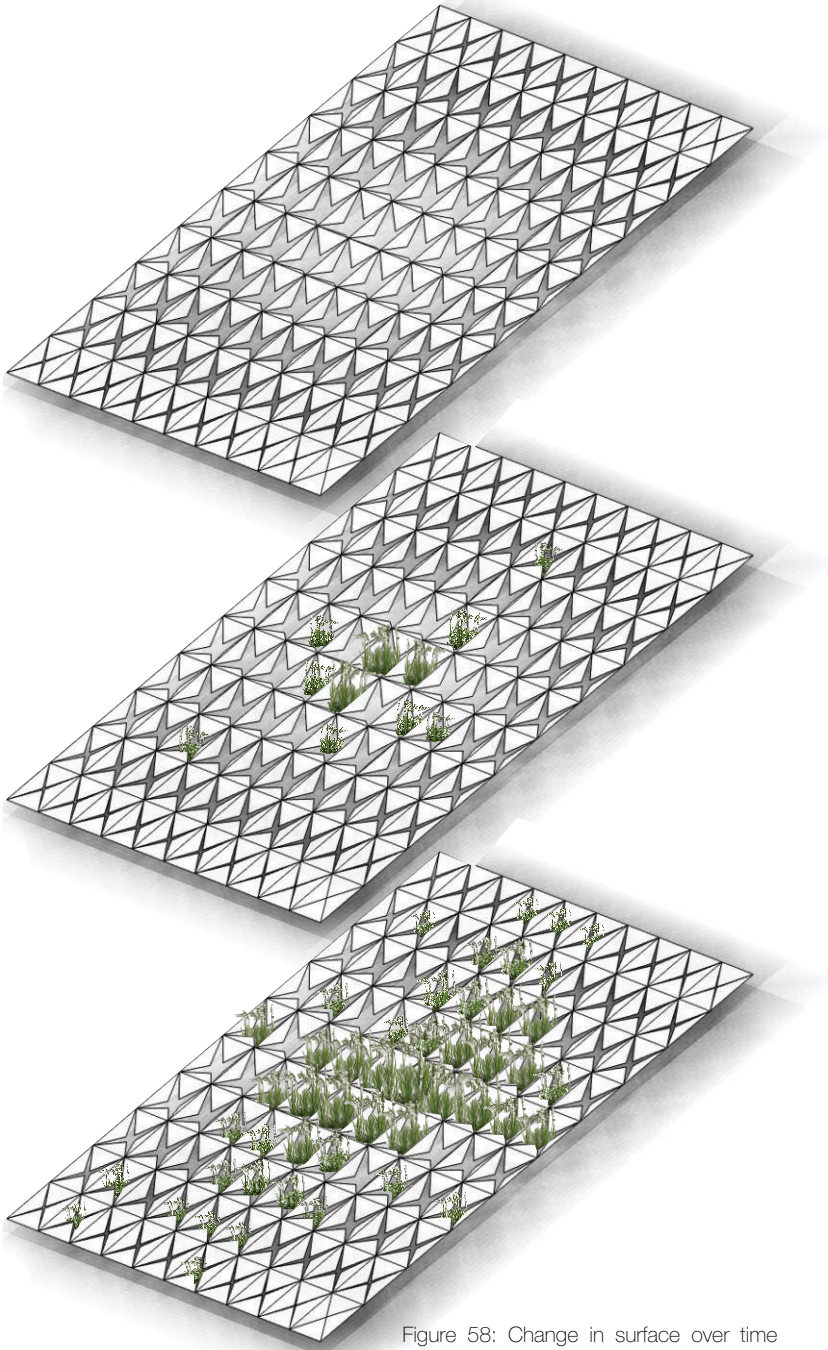

Figure 58: Change in surface over time  
(Author 2016)



UNIVERSITEIT VAN PRETORIA  
UNIVERSITY OF PRETORIA  
YUNIBESITHI YA PRETORIA



# Application of the pavilion

# 9

## Final design

### 9.1 Introduction

The relevance of the pavilion will be tested on two sites that represent open space in Pretoria that will benefit from the pavilion. Venning Park embodies the typical Pretoria urban park (Figure 60), and is used mostly by people employed in the surrounding Sunnyside and Arcadia areas during daytime hours. The rooftop of the Prinschurch building in Pretoria central represents the typical urban renewal project typology. To fully illustrate the forces acting on the landscape, an alternative to steel scaffolding was considered for the final design. Bamboo will not only overcome the weight restrictions of a mobile pavilion, but will change colour upon sun- and rain exposure (see Figure 59). Weathering of exposed bamboo occurs as a result of the interaction between different climatic conditions, such as variations in temperature and relative humidity (Shröder 2016). Pretoria rain events typically occur as short but intense afternoon downpours, preceded and followed by sun exposure. This leads to small cracks on exposed bamboo poles. Furthermore, ultraviolet radiation causes the breakdown of cellulose found in bamboo, and this leads to a change in colour (Shröder 2016).

eliminated: steel as *causa materialis*



*causa materialis*:  
bamboo



Figure 59: Bamboo weathering (Bamboo Import Europe 2016)

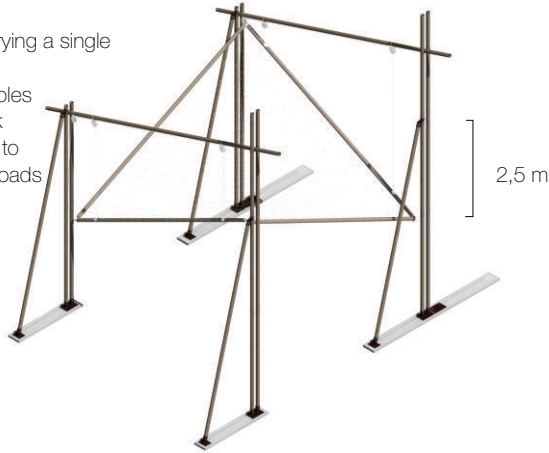

Figure 60: Venning Park's reflection pond (top) and sunken garden (bottom)



1 x structural unit carrying a single canopy

32 x bamboo poles  
4 x 50 mm thick  
spreader plates to  
carry structural loads



structural members designed based on lengths of 2,5 m, as this is the bamboo pole length available from suppliers in Pretoria

1 x hyperbolic paraboloid canopy

8 x bamboo poles  
2 x double block-and-tackle  
pulley systems with hand  
winches

216 textile modules  
optional: plants with irrigation

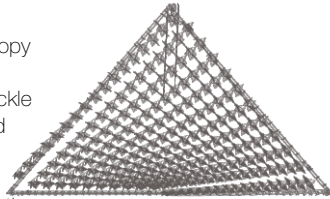

optional:  
plants with irrigation system



thin-film photovoltaic canopy

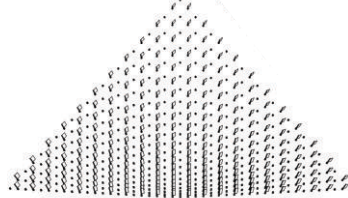

1 x convertible bicycle rack

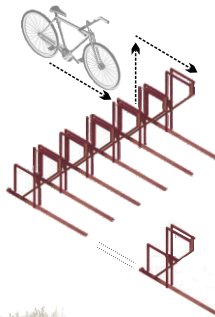

optional:  
seating

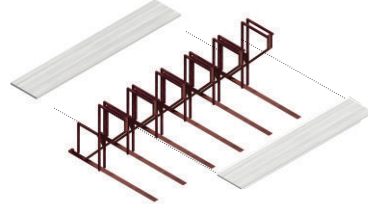

table

surface modules

weathering steel with  
perforations for plant growth  
lightweight composite pavers  
ramp  
edges



type A: 100 x 100 mm perforations  
type B: 75 x 75 mm perforations  
type C: 50 x 50 mm perforations  
type D: 25 x 25 mm perforations

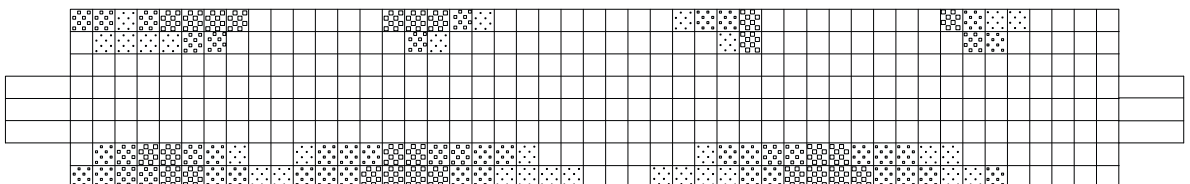

Figure 61: Parts of the pavilion (Author 2016)

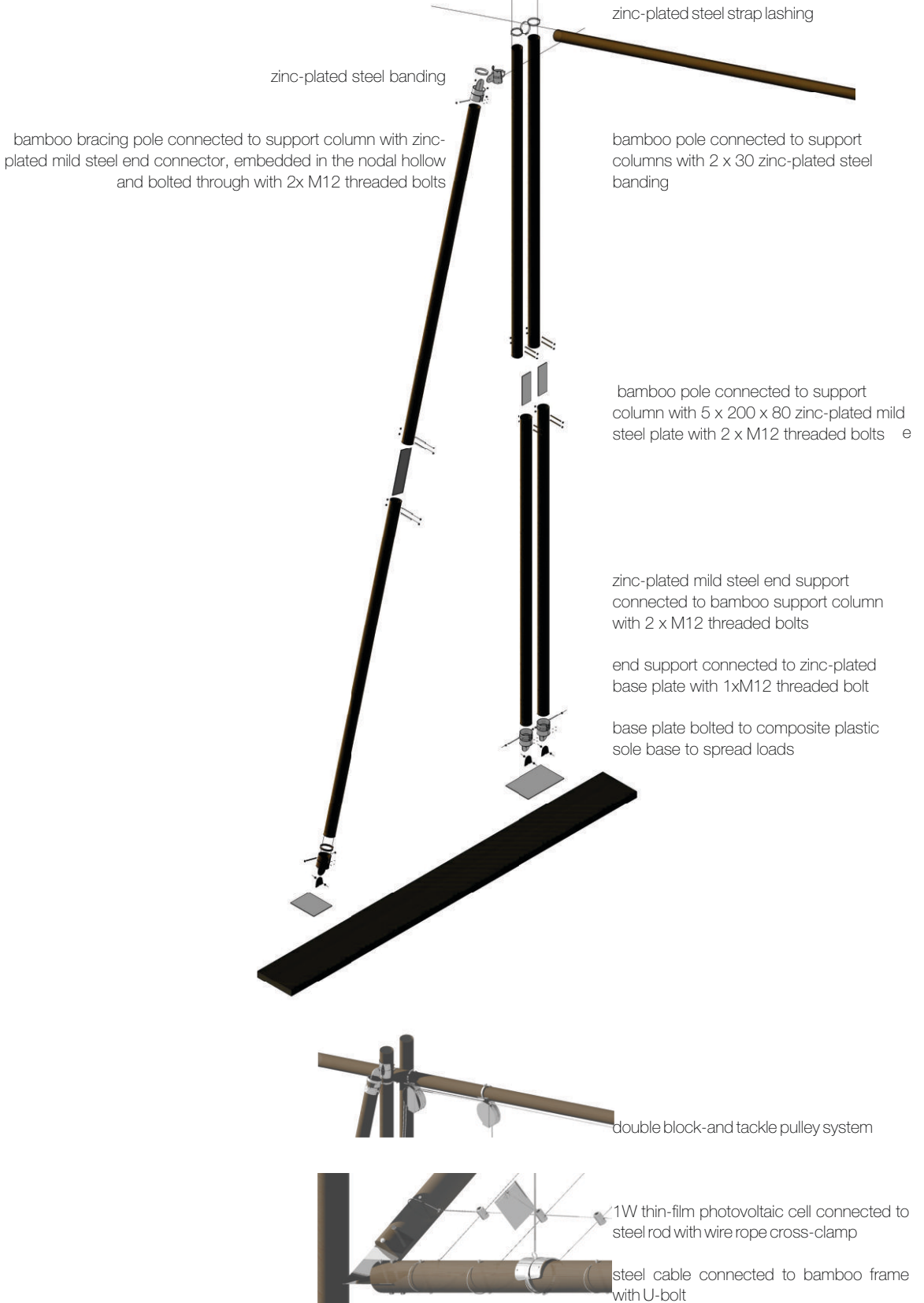

Figure 62: Details (Author 2016)

9.2 Pavilion in the park

Venning Park is situated in Arcadia, bordering Arcadia Primary School and in close proximity to embassies and restaurants (see Figure 65). A small building used to function as a café, but has since closed. The park's three ponds are empty, and only some of the formal flower beds are planted. It has electricity- and water supply and lights for night use. There are some shade trees and benches, but few of the seats are situated in shady areas. The park will benefit from the kit-of-parts pavilion by attracting users and acting as a catalyst point for activity and further development..

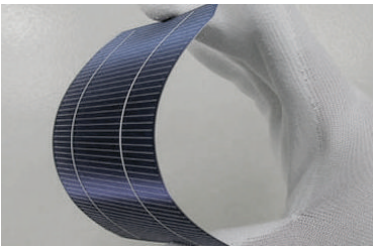

Figure 64: Thin-film photovoltaic cell (Sanyo 2013)

The parts of the pavilion kit that will be suitable for Venning Park are the textile canopy, seating, bicycle rack, serving table, surface and lighting. Furthermore, the energy required to power the luminaires will be provided by a network of thin-film photovoltaic cells (Figure 64). These are not only a light-weight alternative to conventional photovoltaic panels, but will also move in the wind and create a striking visual effect during daytime.

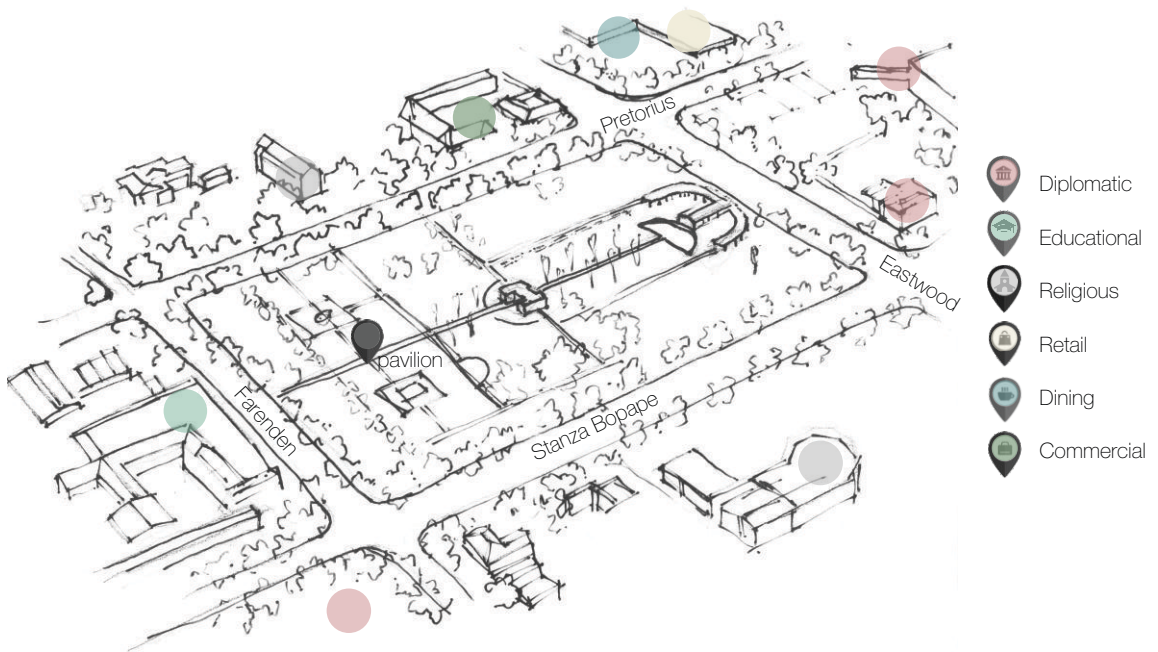

Figure 65: Position and context of the of pavilion in Venning Park (University of Pretoria, 2013)



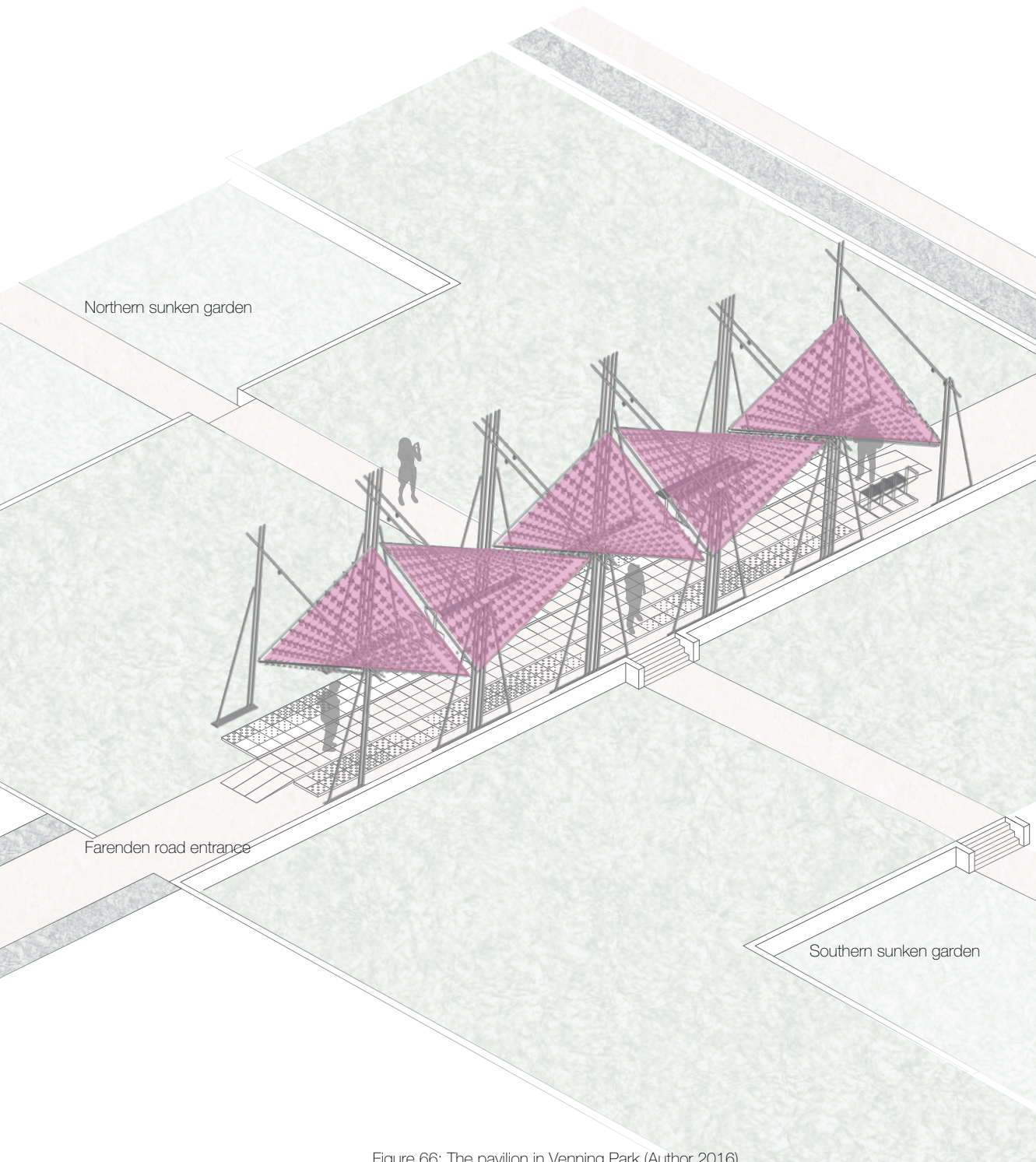

Figure 66: The pavilion in Venning Park (Author 2016)

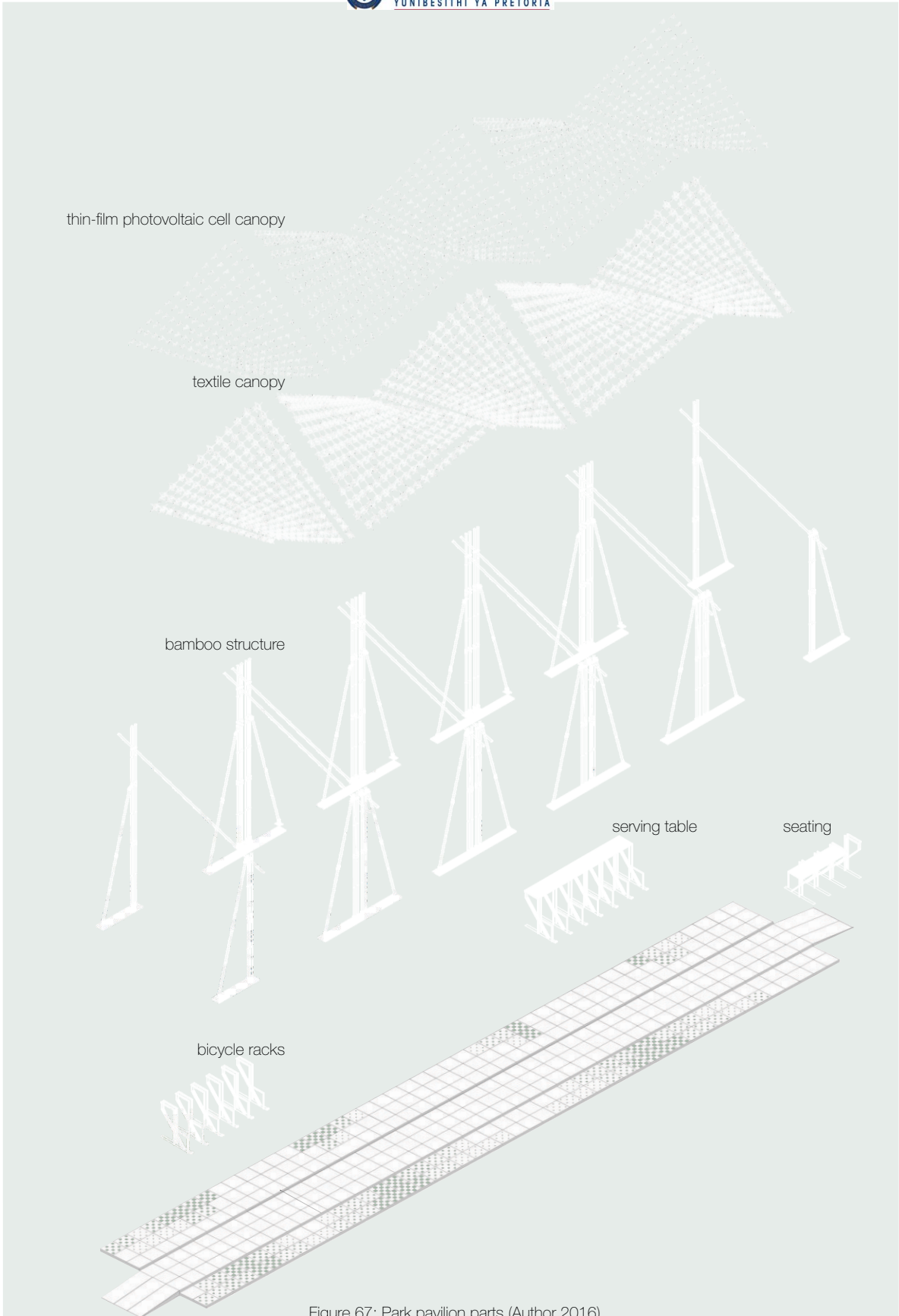

Figure 67: Park pavilion parts (Author 2016)





Figure 68: Section perspective of park pavilion (Author 2016)



### 9.3 Pavilion on an urban rooftop

The Prinschurch building is situated in Pretoria central, and is part of a redevelopment initiative by City Properties. It forms part of 012central, a cluster of refurbished buildings similar to Johannesburg’s Maboneng precinct. The spaces are used for events, and the Prinschurch building is currently an unoccupied building primarily used for its rooftop space overlooking the State Theatre and Sammy Marks Square.

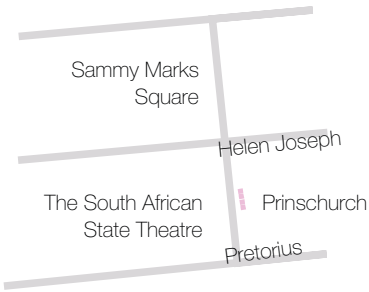

Figure 69: Location of the pavilion as an urban rooftop intervention (Author 2016)

The pavilion will provide not only a sense of human scale to the space, but will also be a source of planting in an urban environment where this is lacking. In addition, it can provide atmospheric lighting and seating. Due to the higher wind speed at this increased altitude, textile weights are added to the spreader plates in order to secure the structure. Due to the relatively flat slope of the roof, no steps are needed, and the gentle slope can be compensated for by adjusting the decking pedestals.



Figure 70: Rooftop event space at the Prinschurch building (Author 2016)



Figure 71: Views from the Prinschurch roof to Sammy Marks Square (top) and the South African National State Theatre (bottom) (Author 2016)



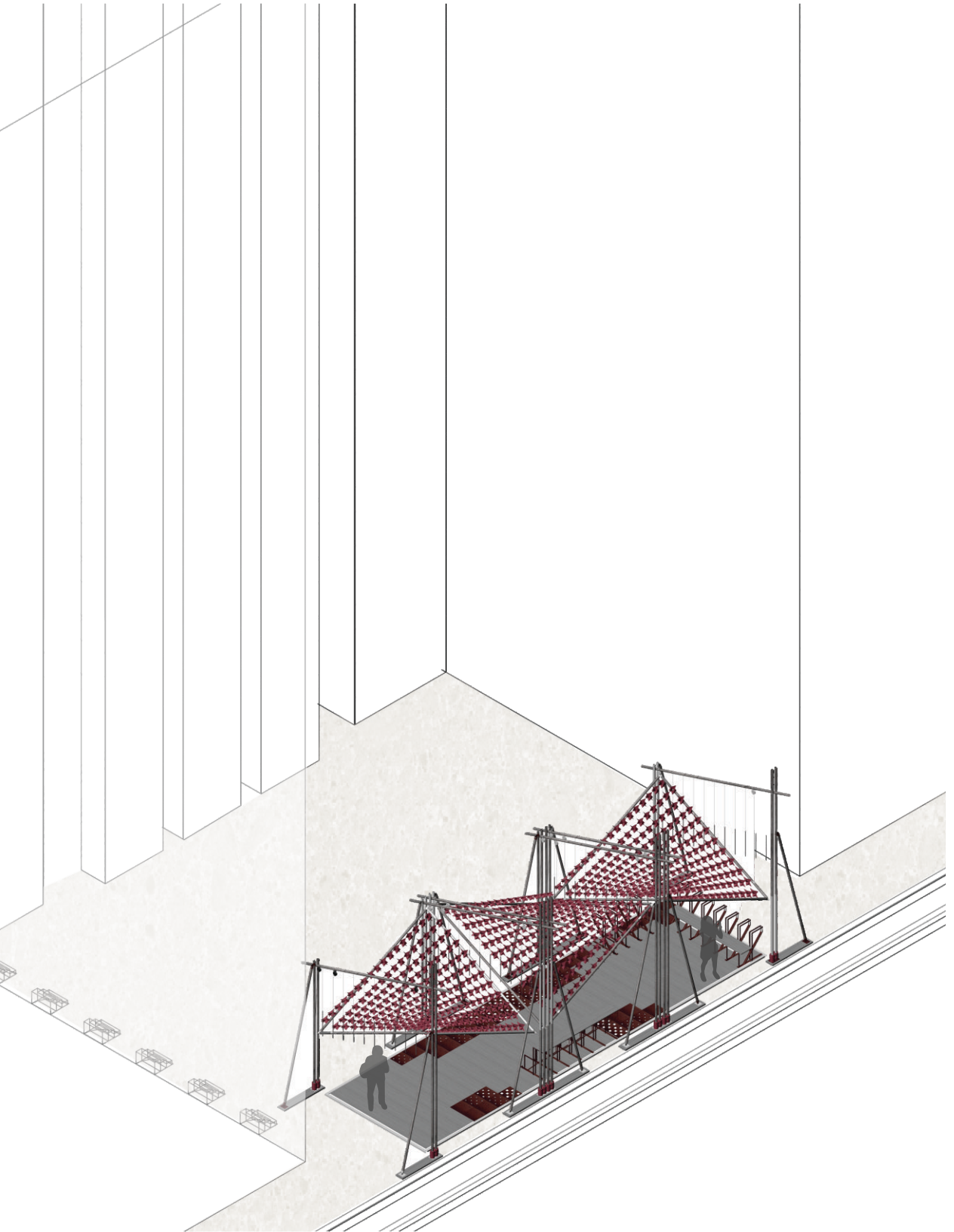

Figure 72: Pavilion on the Prinschurch roof (Author 2016)



Figure 73: Rooftop pavilion parts (Author 2016)

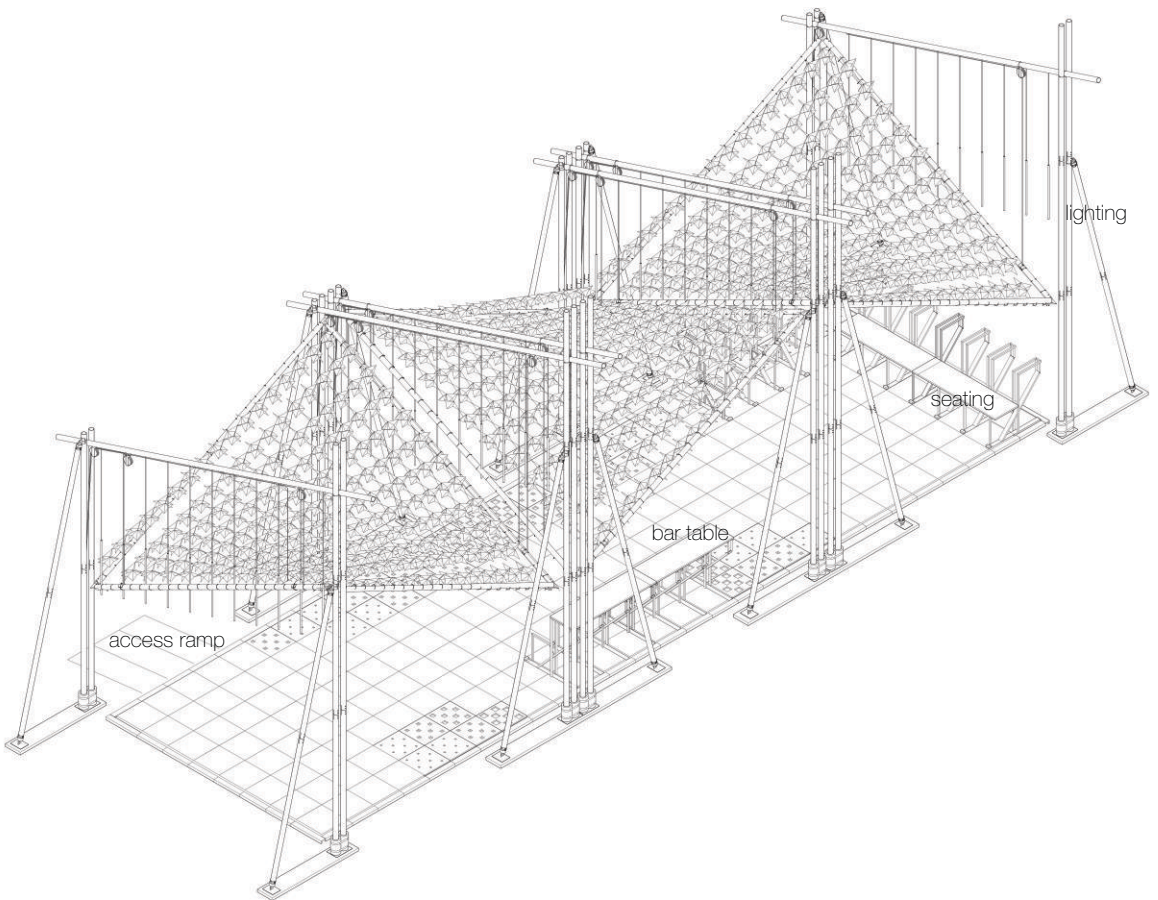

Figure 74: Rooftop pavilion in isolation (Author 2016)

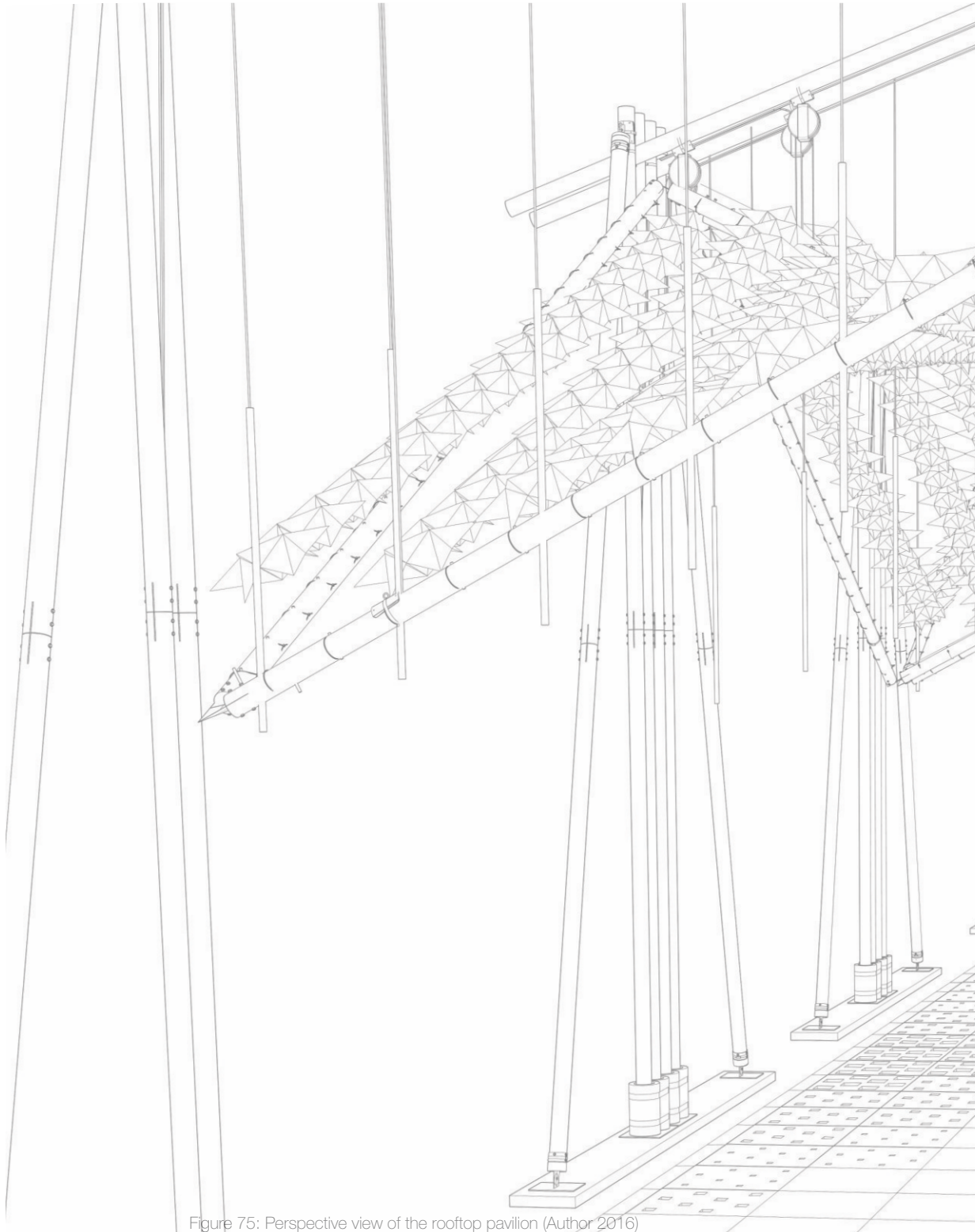

Figure 75: Perspective view of the rooftop pavilion (Author 2016)







# Conclusion

## Knowing through making

Materials influence the way in which they are used in the landscape. Expressive construction encompasses staying true to a material's properties, and revealing their construction techniques in an exaggerated and patterned way. A repetitive pattern of folded textiles used as a canopy not only reveals its construction (folding) but this acts as aesthetic element. Regional aesthetics also plays a role in revealing the material's context. Shweshwe is a textile typically used in traditional Sotho garment construction, and is iconically South African. Landscape architectural tectonics harvests natural forces to reveal, sustain, and guide the form-making of pre-manufactured elements. The patterned and repetitive use of a functional element such as folded surface panels that allow the growth of plants through their openings over time reveals natural processes over time. Through the process of hand-making, combined with computer modelling, the properties and potential of textiles were discovered, leading to an iterative design response which progressed from a detailed to a larger scale.





# References

- ARMSTRONG, D.E. & Bell, C.J. 2015. Space (Un)veiled, in *Space Unveiled: Invisible Cultures in the Design Studio*, edited by Carla Jackson Bell. Abingdon: Routledge.
- BROUGHTON, J.R. 2012. Tectonic Sites: Structuring the Landscape with Textile-Derived Construction Techniques. M.L.A. thesis, University of Illinois, Urbana-Champaign.
- CANDY, L. 2006. Practice based Research: A guide. Creativity and Cognition Studios Report 2006:1. *Internet*: <http://www.creativityandcognition.com/resources/PBR%20Guide-1.1-2006.pdf>. Access 17 April 2016.
- CHING, F.D.K. 2007. *Architecture: Form, Space and Order*, third edition. Hoboken: John Wiley & Sons.
- CREATIVITY & COGNITION STUDIOS. 2015. CC15: Definitions and terms. *Internet*: <http://www.creativityandcognition.com/research/practice-basedresearch/definitions-and-terms/>. Access 17 April 2016.
- DEE, C. 2001. *Form and Fabric in Landscape Architecture*. London: Spon Press.
- DESIGN WITH COMPANY. 2014. Pavilion MMM Narrative. *Internet*: <http://www.designwith.co/testersite/category/pavilion-mmm#3785/pavilion-mmm-narative>. Access 29 August 2016.
- FRAMPTON, K. 1995. *Studies in Tectonic Culture: The Poetics of Construction in Nineteenth and Twentieth Century Architecture*. Cambridge: The MIT Press.
- GAVENTA, S. 2006. *New Public Spaces*. London: Mitchel Beazley.
- GHARIPOUR, M. 2013. *Persian Gardens and Pavilions: Reflections in History, Poetry and the Arts* (Electronic Version). New York City: Pallgrave Macmillan.
- GILLOW, J. & Sentence, B. 2005. *World Textiles: A Visual Guide to Traditional Techniques*. London: Thames & Hudson.
- HANSEN, A. 2011. From Hand to Land: Tracing Procedural Artifacts in the Built Landscape. *Internet*: <http://scenariojournal.com/article/digital-relics/>. Access 2 October 2016.
- HEIDEGGER, M. *The Question Concerning Technology and Other Essays*, translated by William Lovitt. New York: Harper and Row.
- HERZOG & DE MEURON. 2006. 143 Fünf Höfe. *Internet*: <https://www.herzogdemeuron.com/index/projects/complete-works/126-150/143-fuenf-hoefe.html>. Access 30 August 2016.
- HIMEDE, J. 2013. Lilienthal | Zamora. *Internet*: <https://blog.juliohime.com/2013/07/12/lilienthalzamora-is-a-collaboration-between-etta-lilienthal-and-ben-zamora-both-performance-designers-who-together-have-worked-on-many-striking-stage-sets-i-especially-love-last-years-unde/>. Access 30 August 2016.
- HUNT, J.D. 2012. *A World of Gardens*. London: Reaktion Books.
- INGOLD, T. 2013. *Making*. Abingdon: Routledge.
- ISRAEL, K. 2015. Rounding up fashion's grand tour: the Paris Haute Couture A/W 2015-16. *Internet*: <http://www.wallpaper.com/fashion/rounding-up-fashions-grand-tour-the-paris-haute-couture-aw-2015-16>. Access 29 August 2016.
- KIRKWOOD, N. 1999. *The Art of Landscape Detail: Fundamentals, Practices, and Case Studies*. New York: John Wiley & Sons, Inc.

- KRÜGER, S. 2009. *Textile Architecture*. Berlin: Jovis Verlag.
- LAVINIA. 2009. Exhibition in Spain by Cadaval & Solà-Morales. *Internet*: <http://freshome.com/2009/12/01/exhibition-in-spain-by-cadaval-sola-morales/>. Access 30 August 2016.
- LISE, B. 2006. Fashion and Landscape: A Bricolage Navigation. MLA Thesis, University of Manitoba, Winnipeg, Canada.
- MOORE, R. 2013. The Pop-Up Designs Changing the City Landscape. *The Guardian*, 3 August 2013. *Internet*: <https://www.theguardian.com/artanddesign/2013/aug/03/pop-up-designs-architecture-london>. Access 27 August 2016.
- NIMKULRAT, N. 2012. Hands-on Intellect: Integrating Craft Practice into Design Research. *International Journal of Design*, 6(3):1-14.
- PLUMTRE, G. Palmer, H. & Garnock, J. 1998. *Garden Ornament: Five Hundred Years of History and Practice*. London: Thames and Hudson.
- RYAN, T.R. 2011. *Detailing for Landscape Architects*. Hoboken: John Wiley & Sons
- SAMSON, M.D. 2015. *Hut Pavilion Shrine: Architectural Archetypes in Mid-Century Modernism*. Abingdon: Routledge.
- SCHRÖDER, S. 2016. General Properties of Bamboo and Maintenance Tips. *Internet*: <https://www.bambooimport.com/en/blog/properties-of-bamboo-and-maintenance-tips>. Access 5 December 2016.
- SCHWARTZ, M. 1993. Landscape and Common Culture since Modernism, in *Modern Landscape Architecture: a Critical Review*, edited by M. Treib. Cambridge: The MIT Press.
- SOUTH AFRICAN LED NETWORK [S.a.]. Informal Economy. *Internet*: <http://led.co.za/topic/informal-economy>. Access 22 October 2016.
- STAMP, E. 2015. Architecture Firm SelgasCano Constructs a Colorful Pavilion at Denmark's Louisiana Museum of Modern Art. *Internet*: <http://www.architecturaldigest.com/story/louisiana-hamlet-pavilion-selgascano>. Access 29 August 2016.
- STERN, A. 2015. The Para-Pavilion: towards a new aesthetics of parametrically designed pavilions. The Human (Parameter) - Parametric Approach in Israeli Architecture exhibition book, Curated by Jonathan Lazovski & Yuval Kahlon for ZEZEZE Architecture Gallery, Tel-Aviv.
- TRAMONTIN, M.L. 2006. Textile Tectonics: An Interview with Lars Spuybroek. *Architectural Design*, November/December 2006:52-59.
- WAINWRIGHT, O. 2013. Louis Kahn: the Brick Whisperer. *Internet*: <https://www.theguardian.com/artanddesign/2013/feb/26/louis-kahn-brick-whisperer-architect>. Access 2 October 2016.
- WEE, D. 2013. Yasumichi Morita Redesigns Kyoto's Arashiyama Station. *Internet*: <http://www.blouinartinfo.com/news/story/930630/yasumichi-morita-redesigns-kyotos-arashiyama-station>. Access 30 August 2016.
- WHERRY, L. 2015. Knowing Through Making. MInt(Prof) dissertation, University of Pretoria, Pretoria.
- WINSTON, A. 2016. Burnt, Recycled, Sold: the Fate of 2015's Temporary Pavilions. *Internet*: <http://www.dezeen.com/2016/06/14/2015-temporary-pavilions-fate-burnt-recycled-storage-sold-serpentine-gallery-milan-expo-moma-ps1/>. Access 28 August 2016.
- WINTERBOTTOM, D.M. 2000. *Wood in the Landscape*. Hoboken: John Wiley & Sons, Inc.

Other works consulted:

- BOOTH, N. K. 2012. *Foundations of Landscape Architecture*. Hoboken: John Wiley & Sons.
- GARCIA, M. (Ed.) 2006. Architecture + Textiles = Architextiles. *Architectural Design*, November/December 2006:5-12.
- SHULMAN, N. 2014. Fashion & Gardens exhibition booklet, Garden Museum, London.
- VLOK, E. 2006. The Textile and Clothing Industry in South Africa, in *The Future of the Textile and Clothing Industry in Sub-Saharan Africa*, edited by H. Jauch & R. Traub-Merz. Bonn: Friedrich-Ebert-Stiftung.

Image references:

- BAMBOO IMPORT EUROPE. 2016. Bamboo discolouration. *Internet*:  
<https://www.bambooimport.com/image/Blog/eigenschappen/bamboe-vergrijzing.jpg>. Access 5 December 2016.
- CADAVAL & SOLÀ-MORALES. 2009. Eyes of the World. *Internet*: [http://www.caso.com/project.php?project\\_id=29](http://www.caso.com/project.php?project_id=29). Access 24 October 2016.
- DESIGN WITH COMPANY. 2014. MMM Pavilion. *Internet*: <http://www.designboom.com/wp-content/uploads/2014/05/design-with-co-pavilion-mmm-designboom-01.jpg>. Access 24 October 2016.
- DIOR. 2015. Dior Haute Couture Fall Winter 2015-2016. *Internet*:  
[http://www.dior.com/diormag/sites/default/files/styles/dn\\_grid\\_mobile\\_full/public/slideshow\\_grid/multiple\\_media/01\\_defilehcah1516\\_scenophotos.jpg?itok=KPnhg1R1](http://www.dior.com/diormag/sites/default/files/styles/dn_grid_mobile_full/public/slideshow_grid/multiple_media/01_defilehcah1516_scenophotos.jpg?itok=KPnhg1R1). Access 24 October 2016.
- DIRAND, A. 2015. Dior Spring 2015 Couture Presentation. *Internet*:  
[http://tmagazine.blogs.nytimes.com/2015/01/26/dior-couture-stage-set-design-history/?\\_r=0](http://tmagazine.blogs.nytimes.com/2015/01/26/dior-couture-stage-set-design-history/?_r=0). Access 24 October 2016.
- DIVINECACTUS. 2014. Ceropegia woodii. *Internet*: <https://www.amazon.co.uk/DivineCactus-CEROPEGIA-WOODII-String-of-Hearts-11cm-wide-hanging-pot/dp/B00M27CAP2>. Access 25 October 2016.
- FLEUR. 2016. String of pearls. *Internet*: <http://oururbanbox.com/string-of-pearls/#comment-7714>. Access 25 October 2016.
- JAYJAYC. 2011. Chlorophytum comosum 'Variegatum' with green leaves and white margins. *Internet*:  
<https://www.flickr.com/photos/jayjayc/6206521819/in/album-72157594392643445/>. Access 25 October 2016.
- KVARTBLOG. [S.a.] Asparagus densiflorus. *Internet*: <http://econet.ru/articles/117622-rasteniya-v-interiere-vashego-doma>. Access 25 October 2016.
- LAURENS. 2007. A sunken garden in Venning Park. *Internet*:  
[https://commons.wikimedia.org/wiki/File:Venningpark\\_-\\_gesonke\\_tuin\\_2.jpg](https://commons.wikimedia.org/wiki/File:Venningpark_-_gesonke_tuin_2.jpg). Access 5 December 2016.
- LILIENTHAL, E. 2012. Through Hollow Lands. *Internet*: <http://www.ettalilienthal.com/thl/>. Access 24 October 2016.
- MATSUE VOGEL PARK. 2008. Pelargonium tongaense. *Internet*: <http://vogelpark.blog47.fc2.com/blog-entry-179.html>. Access 25 October 2016.

SANYO. 2013. *Internet*: <http://iecetech.org/issue/2013-10/Helping-turn-solar-power-into-electricity>. Access 5 December 2016.

SELGASCANO. 2016. Louisiana Hamlet Pavilion. *Internet*: [https://static.dezeen.com/uploads/2016/02/kibera-louisiana-selgascano-humanitarian-architecture\\_dezeen\\_936\\_14.jpg](https://static.dezeen.com/uploads/2016/02/kibera-louisiana-selgascano-humanitarian-architecture_dezeen_936_14.jpg). Access 24 October 2016.

SUBTILITAS. 2011. Hanging Plants, Pendant Lights, and Reflective Glass. *Internet*: <http://www.subtilitas.site/post/2861893036/its-difficult-for-me-to-appreciate-shopping-mall>. Access 24 October 2016.

TODODESIGN. 2014. Paradise on Earth. *Internet*: [http://www.arq4design.com/tododesign/wp-content/uploads/1374208\\_566082976779705\\_1456939151\\_n.jpg](http://www.arq4design.com/tododesign/wp-content/uploads/1374208_566082976779705_1456939151_n.jpg). Access 24 October 2016.

#### Parametric definitions

BUTHKE, J. & Brauer, R. 2011. Folded structures. *Internet*: <http://oooja.dk/2011/09/04/folded-structures/>. Access 5 December 2016.

WALLACE. 2011. Grasshopper tutorial: folded plate structure. *Internet*: <https://vimeo.com/33136318>. Access 5 December 2016.



# Appendix

# A

## Instructions

Samples 1, 2, 3:

1. Make slipknot:

- 1.1. Measure three forearm-lengths of rope/twine (henceforth referred to simply as “yarn”) for the tail
- 1.2. Place the working yarn to the left; make a loop with the yarn and ensure that the long end of the tail crosses the shorter end; hold the crossing between index and middle fingers
- 1.3. Pull the short end of the tail through the loop and tighten

2. Slide slipknot over right wrist

3. Create stitches:

- 3.1. Hold the working yarn in between the ring- and pinkie fingers of left hand, with the palm of the hand facing towards the knitter. Ensure the working yarn is further away from the body, and that the tail is the strand closer to the body
- 3.2. Place left thumb and left middle finger in gap between the working yarn and tail
- 3.3. Slide the working yarn over the left middle finger, and the tail over the thumb. Ensure that palm faces upwards.
- 3.4. Place right hand in gap between the yarn on left hand closest to the body, and then over the one furthest away from body. Loop hand towards the body and slide the loop over wrist.
- 3.5. Repeat until the required number of stitches is achieved (10 stitches in Samples 1, 2 and 3)

4. Hold the working yarn in the right hand. Ignore the tail end for the remainder of the knitting process.

5. Pull the stitch closest the wrist over the right hand, and drop it. Keep the working yarn in the right hand.

6. Place the left hand through the loop created, from the back towards the body.

7. Tighten the yarn slightly over the left arm.

8. Repeat Steps 4 and 5.

9. Place the left hand through the loop created, from the front and away from the body.

10. Repeat Steps 8 and 9 until all of the stitches are on the left arm.

11. Hold the working yarn in the left hand.

12. Pull the stitch closest the wrist over the left hand, and drop it. Keep the working yarn in the left hand.

13. Place the right hand through the loop created, from the back towards the body.

14. Tighten the yarn slightly over the right arm.

15. Repeat Steps 11 and 12.

16. Place the right hand through the loop created, from the front and away from the body.

17. Repeat Steps 15 and 16 until all of the stitches are on the right arm.

18. Carry on knitting until the desired length of sample is achieved.

19. Cast off (if stitches are on the right arm):

- 19.1. Follow Steps 4, 5 and 9 to make two stitches over the left arm
- 19.2. Take the stitch closest to the body with the right hand, and pull over the left hand. Drop the stitch.
- 19.3. Follow Steps 4, 5 and 9 to make one more stitch.
- 19.4. Repeat Step 19.2.
- 19.5. Repeat Steps 19.1 to 19.4 until all of the stitches have been cast off.

If stitches are on the left arm, follow Steps 19.1 – 19.5, but switch the arm orientation.

20. Trim the tail yarn and working yarn with scissors.

Sample no.	Purpose	Material	Fabrication technique	Notes
1	To create shade-providing, overhead-defining element	Polypropylene twine: 3 mm diameter Breaking strength: 50 kg	Warp arm knitting- no tools required	Based on 10 garter stitches
2	To create shade-providing, overhead-defining element	Flat polyethylene braided ski rope: 10 mm diameter Breaking strength: 330 kg	Warp arm knitting- no tools required	Based on 10 garter stitches
3	To create shade-providing, overhead-defining element	Jute braided rope: 7 mm diameter Breaking strength: 154 kg	Warp arm knitting- no tools required	Based on 10 garter stitches
4	To explore folding as spatial element	210 g/m <sup>2</sup> paper	Folding by hand	Basic parabola fold (Jackson 2011)
5	To explore the possibilities of folding as a means to create space as well as to containment for plants	160 g/m <sup>2</sup> paper	Folding by hand	Basic V-pleat (Jackson 2011)
6	To explore the possibilities of folding as a means to create space as well as to containment for plants	160 g/m <sup>2</sup> paper	Folding by hand	Multiple V-pleats (Jackson 2011)
7a	To make a mould to shape textiles	2 sheets of 1mm thick cardboard	Folding by hand	Based on sample 6.
7b	To explore textile manipulation	Weed-control textile  © University of Pretoria	Oven-baking in cardboard mould at 120 °C for 60 minutes.	Based on sample 6

Details	Observations		Opportunities
Length of twine used: 100 m Dimensions: 1800 x 210 mm Area: 0.378 m <sup>2</sup> at rest Time taken: 1.5 hours	 <p>UNIVERSITEIT VAN PRETORIA UNIVERSITY OF PRETORIA YUNIBESITHI YA PRETORIA</p> <ul style="list-style-type: none"> <li>-Elastic properties of the sample cause irregularities in shape-expansion at points of restraint and contraction in areas with no contact to external support.</li> <li>-Twine is too thin to provide sufficient shade</li> <li>-Sample weighed down at its centre of gravity- appears drooping and “weak”</li> <li>-Yarn to surface ratio is small.</li> <li>-Shadows and texture form visual interest</li> </ul>	<ul style="list-style-type: none"> <li>Use thicker twine for               <ul style="list-style-type: none"> <li>-sturdier sample</li> <li>-smaller stitch sizes to increase shading capacity</li> </ul> </li> </ul> <p><i>How is this sample more appropriate than conventional shade structures?</i></p>	<ul style="list-style-type: none"> <li>-Even though sample appears “weak”, it can have poetic and dynamic movement and shadow-casting properties</li> <li>-Can be draped</li> </ul>
Length of rope used: 15 m (longest available length in-store) Dimensions: 500 x 160 mm Area: 0.08 m <sup>2</sup> Time taken: 20 minutes	<ul style="list-style-type: none"> <li>-Sample area very small</li> <li>-Difficult to achieve a uniform knit with rope of that diameter</li> <li>-Untidy appearance</li> <li>-Keeps its shape</li> <li>-Unravels easily: rope surface is smooth, and too thick for sufficient control</li> <li>-Provides more shade than sample 1</li> </ul>	<ul style="list-style-type: none"> <li>-Use rope or twine that is thinner than sample 2, but thicker than sample 1.</li> <li>-Rope or twine to have better gripping qualities.</li> </ul>	<ul style="list-style-type: none"> <li>-Can have robust qualities on ground plane</li> </ul>
Length of rope used: 30 m (longer lengths did not fall within allocated budget) Dimensions: 700 x 240 mm Area: 0.168 m <sup>2</sup> Time taken: 45 minutes	<ul style="list-style-type: none"> <li>-Sample area relatively small- <i>not cost-effective?</i></li> <li>-More effective as shade-providing element than sample 1</li> <li>-More sturdy than sample 1</li> <li>-More neat than sample 2</li> <li>-Rope doesn’t unravel like sample 2</li> <li>-Shadows and texture form visual interest</li> <li>- Provides greater width for same number of stitches used (in comparison to sample 1)</li> </ul>	<ul style="list-style-type: none"> <li>-Natural fibres have more grip than synthetic rope</li> </ul> <p><i>Is knitting the most effective method to create space-defining elements?</i></p>	<ul style="list-style-type: none"> <li>-Can have robust qualities on ground plane</li> </ul>
Paper dimensions before folding: 380 x 380 mm Dimensions at rest: 360 x 360 mm Span area at rest: 0.130 m <sup>2</sup> Time taken: 45 minutes	<ul style="list-style-type: none"> <li>-Can expand and collapse</li> <li>-Offers spatial definition in multiple dimensions and planes</li> <li>-Can be up-scaled easily</li> </ul>	<ul style="list-style-type: none"> <li>-Use different V-folds to investigate containing properties further</li> </ul>	<ul style="list-style-type: none"> <li>-Can offer visually appealing spatial definition</li> </ul>
Paper dimensions before folding: 280 x 200 mm Dimensions at rest: 265 x 190 mm Span area at rest: 0.018 m <sup>2</sup> Time taken: 30 minutes	<ul style="list-style-type: none"> <li>-Can expand and collapse more easily than sample 4</li> <li>-Valleys have intrinsic containment capacity</li> </ul>	<ul style="list-style-type: none"> <li>-More “compartments” could further define overhead pockets for planting.</li> </ul>	<ul style="list-style-type: none"> <li>-Can offer spatial definition on different planes</li> </ul>
Paper dimensions before folding: 200 x 150 mm Dimensions at rest: 170 x 140 mm Span area at rest: 0.0238 m <sup>2</sup> Time taken: 45 minutes	<ul style="list-style-type: none"> <li>-Pattern appears more promising for containment</li> </ul>	<ul style="list-style-type: none"> <li>-Edges are open, thus patterns with contained edges should be investigated as containment options.</li> </ul>	<ul style="list-style-type: none"> <li>-Due to its flexible yet rigid nature it can be used on the ground plane for e.g. erosion control.</li> </ul>
Cardboard dimensions before folding: 250 x 250 mm Dimensions at rest: 230 x 230 mm Span area at rest: 0.053 m <sup>2</sup> Time taken: 20 minutes per sheet			
Dimensions before folding: 250 x 250 mm Dimensions at rest: 230 x 230 mm	<ul style="list-style-type: none"> <li>-Successful transfer of paper folding onto textile.</li> </ul>	<ul style="list-style-type: none"> <li>-Folded textiles can be reproduced easily with the mould.</li> </ul>	See sample 6



UNIVERSITEIT VAN PRETORIA  
UNIVERSITY OF PRETORIA  
YUNIBESITHI YA PRETORIA





# Appendix

# B

## Parametric modeling scripts

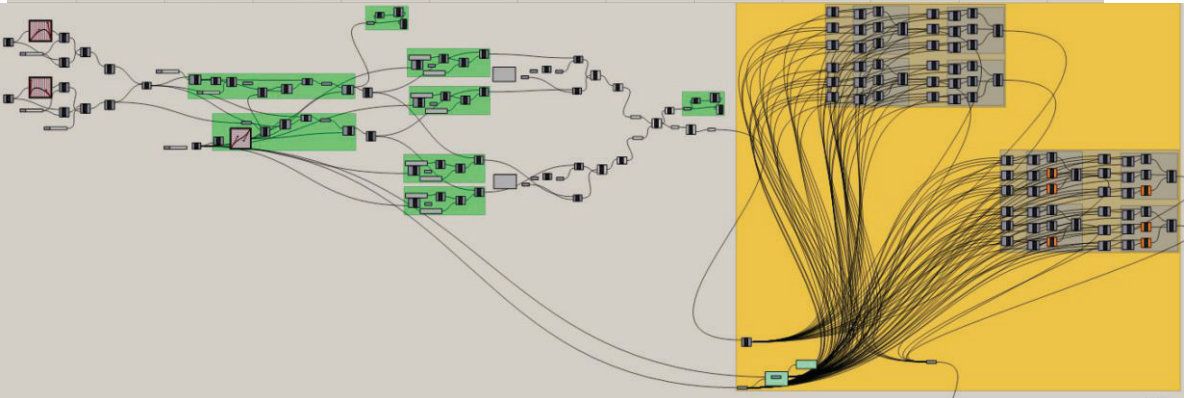
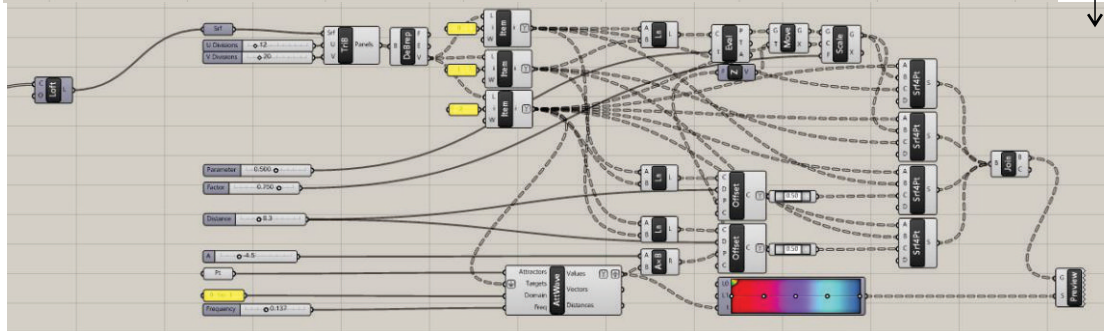
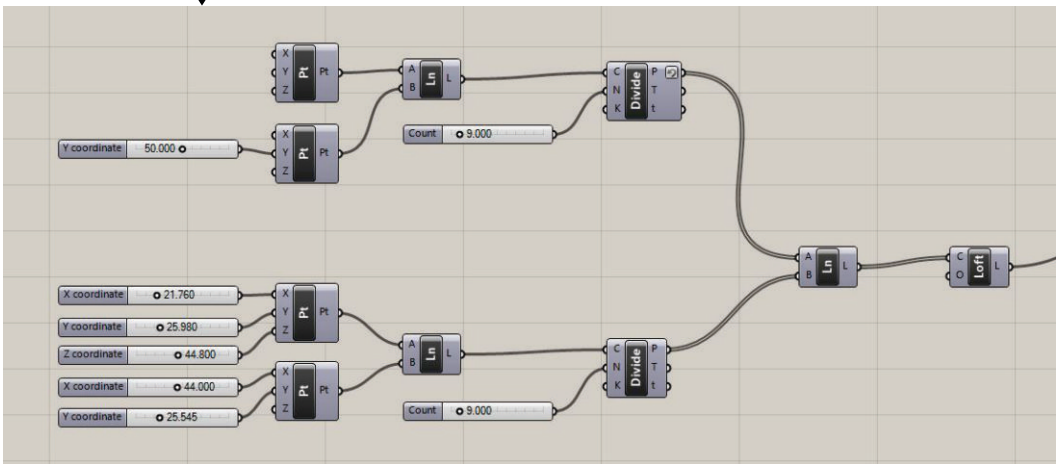
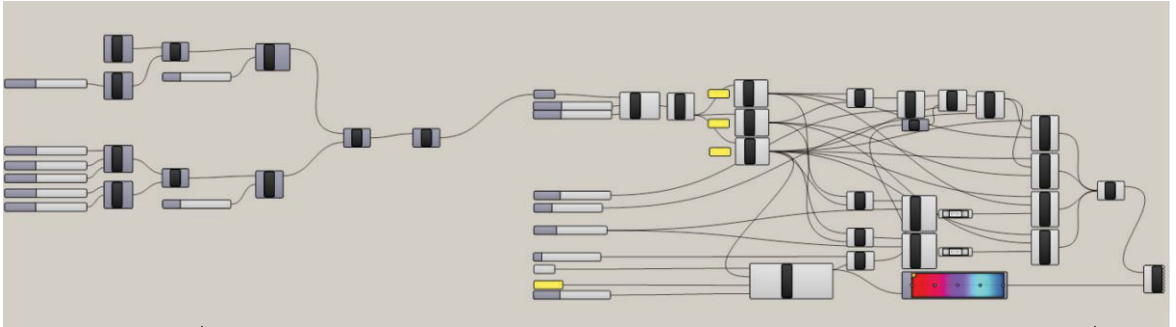



Thumbnail unit 1

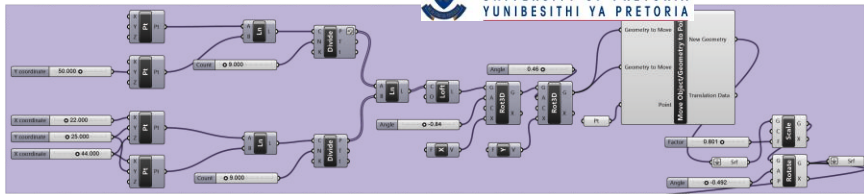

Thumbnail overview

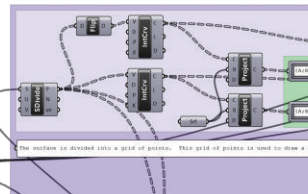

Thumbnail pattern

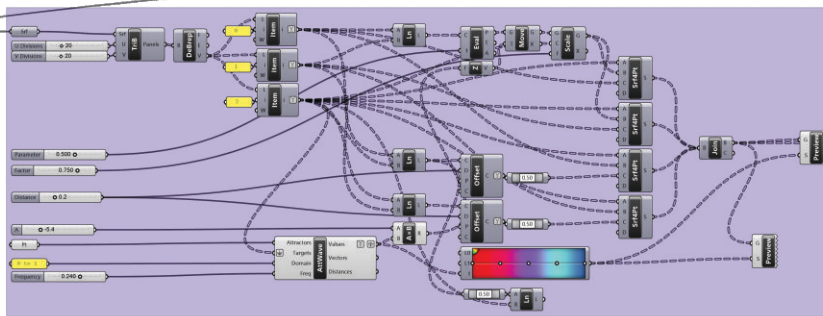

Thumbnail glass

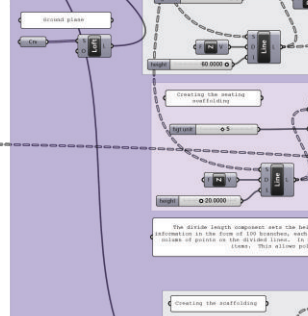

Thumbnail unit 2

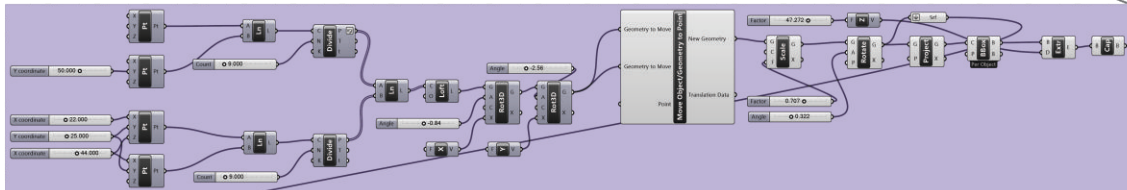

Thumbnail pattern

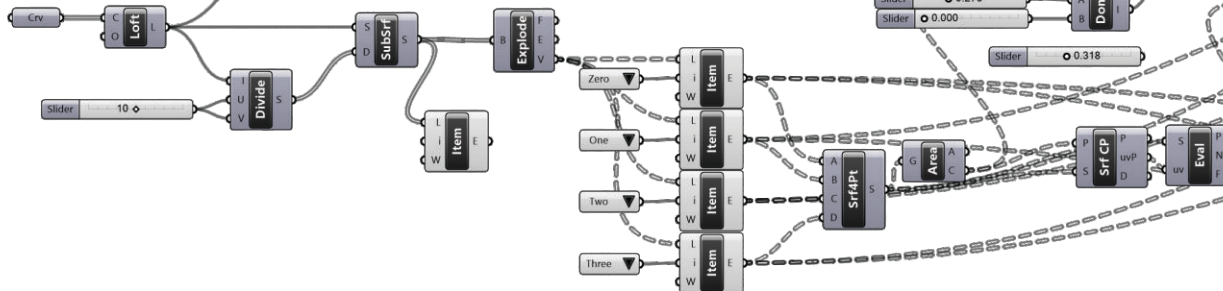
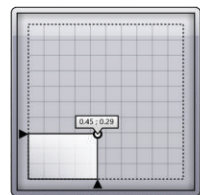
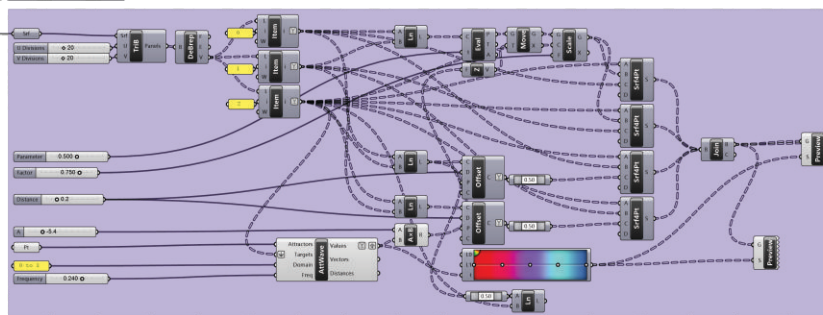

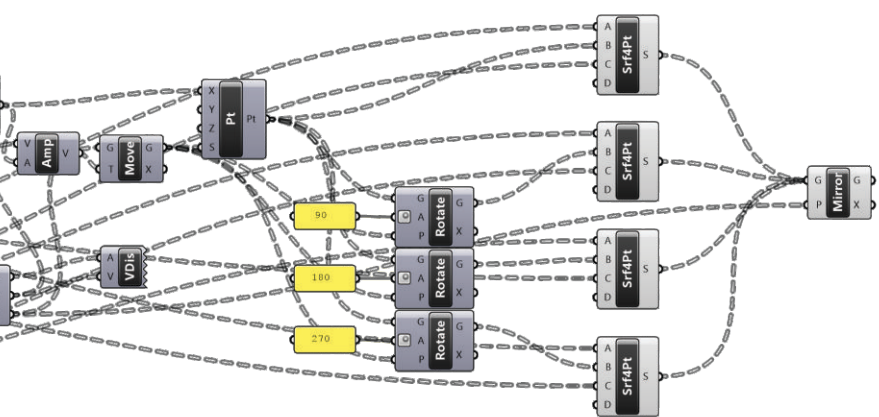
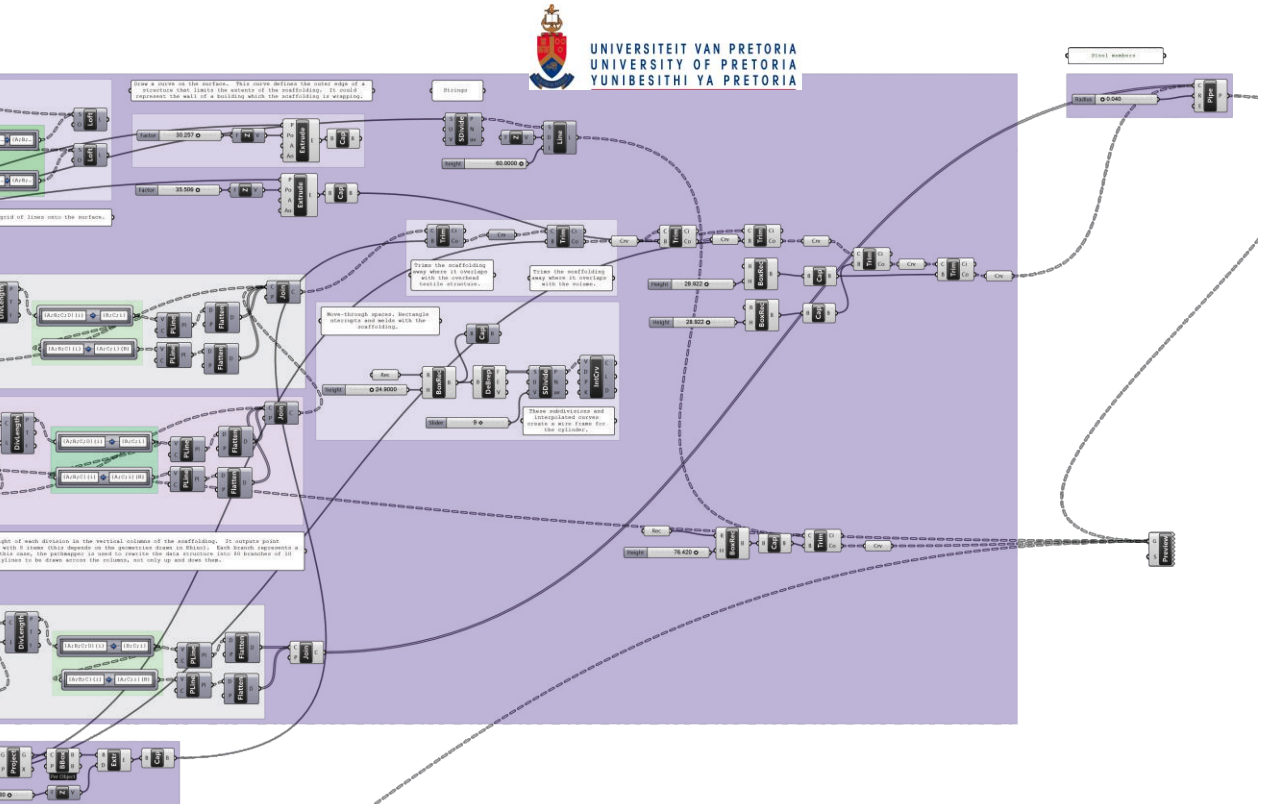



UNIVERSITEIT VAN PRETORIA  
UNIVERSITY OF PRETORIA  
YUNIBESITHI YA PRETORIA



Appendix

# C

## Process work

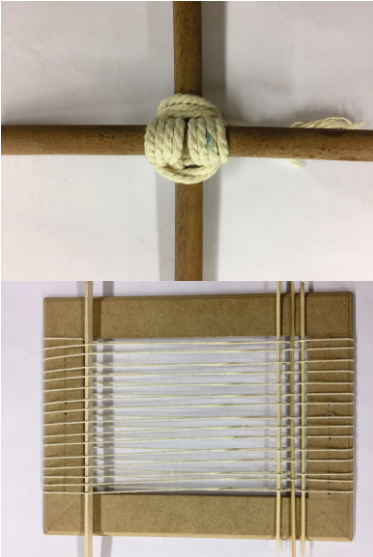

Knotting and weaving explorations

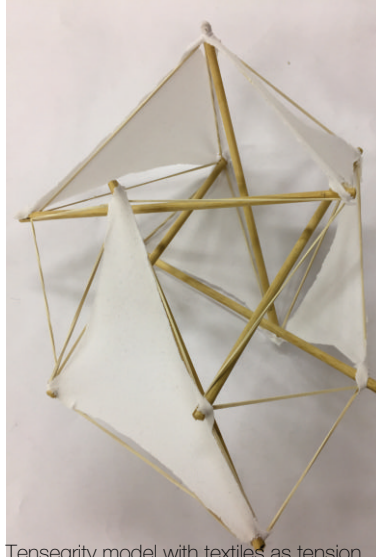

Tensegrity model with textiles as tension members

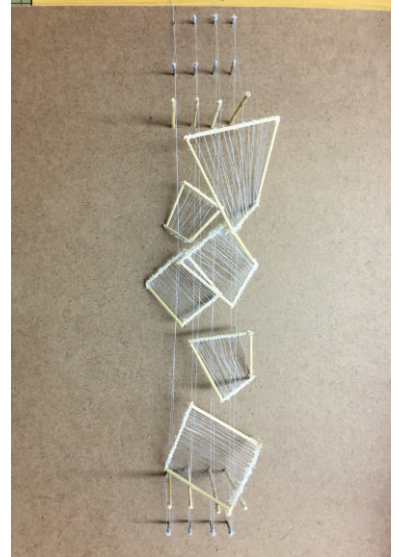

Weight of *Asparagus plumosus*



Weight of a textile pocket once saturated with water