

A Sense of Place and Belonging

Creating Good Neighbourhoods through Productive Social Infrastructure

by Siyabonga Lunga Mahlangu

^ Sense of Place and Belonging

Creating Good Neighbourhoods through Productive Social Infrastructure

Siyabonga Lunga Mahlangu

Course coordinator: Arthur Barker

Study Leader: Emmanuel Nkambule

Submitted in Partial fulfillment of the requirements of the degree Magister of Architecture (Professional).

Department of Architecture

Faculty of Engineering, Built Environment and Information Technology,

University of Pretoria

South Africa

Pretoria, South Africa 2016

PROJECT SUMMARY

- Title:** A Sense of Place and Belonging- Creating Good Neighbourhoods through Productive Social Infrastructure.
- Project Programme:** Bokamoso Service Centre, Thusong Service Centre, administration and consultation facilities for the CPF (Community Policing Forum) and the COPC (Community Orientated Primary Care), Community Centre, Public space
- Address:** **ERF 32996**, C/o Hector Peterson Road & Tshukudu Road , Lusaka, Mamelodi East, Tshwane, Gauteng.
- Site Location (GPS Coordinates):** Latitude: 25°43'25.31"S; Longitude: 28°25'15.02"E
- Research Field:** Human Settlements and Urbanism
- Clients:** Community of Lusaka, The COPC (Community Orientated Primary Care) + South African Department of Health and CPF (Community Policing Forum) + SAPS (South African Police Service) and Tshwane Municipality
- Keywords:** Public space, Public amenities, Access, Catalyst, Place making, Social infrastructure, Temporality, Permanence.
- Site Description:** Victory soccer field, Lusaka , Mamelodi East

Acknowledgments:

Thank you to all those that made this possible:

Camilo Mogni and Lina for the support and encouragement and the office of ST Nubian Architects for their resources.

Khutso Chuene and Gontse Segone for dealing with me through my journey to completing this dissertation.

Dr. Emmanuel Nkambule for his vision when mine was diminishing.

Petrus (Peet) Wolmarans for the hours of help and entertainment throughout the year and lastly thank you to Bollard Management for the laughs that carried us through this tough yet rewarding journey.

A special thanks to my mother and sister for pushing me through and helping me in my time of need.



Social infrastructure:

“Refers to the range of activities, organisations and facilities supporting the formation, development and maintenance of social relationships in a community” (Futurecommunities.net, 2016).

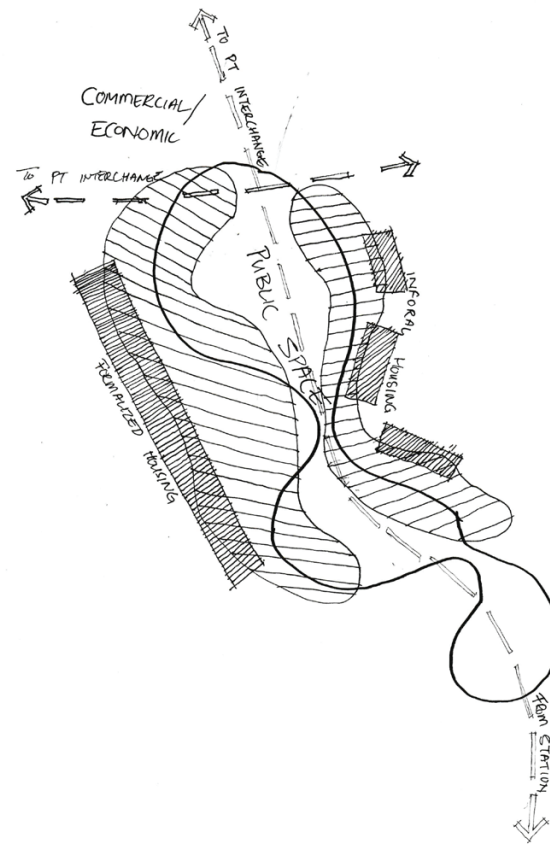

Figure 1: Diagram illustrating a new way of conceptualising the interaction between a public building and a public space (Author 2016).

ABSTRACT

The township in the South African context is a unique consequence of Apartheid spatial planning. Envisaged as settlements for black labourers on the outskirts of the city, they have become home to many South Africans. Mamelodi was established as an effectively designed township for labourers working in Pretoria, and grew at an exponential rate, leading to a sizeable demand for housing. A mass provision of housing was implemented then and, post 1994 to meet this demand. The same strategy of housing is still continuing through the Reconstruction and Development Programme (RDP). This provision of housing has not been complimented by a provision of public amenities and has led to monotonous neighbourhoods filled with housing and no public space.

The ever growing community of Lusaka, in the east of Mamelodi, is a community with a landscape of housing without public amenities and public spaces. This neighbourhood has large amounts of people moving in and out, with some people seeing it as a place of permanence and some as a temporary detour. This influx of people and the duality of temporality and permanence creates a very dynamic society, one that the current architecture cannot respond to. The new architecture has to address the above mentioned issues, providing the community with access to public amenities and public spaces that add value to their environment. The solutions derived can be discussed and used to address similar problems plaguing townships around South Africa.

Architecture is for the people.

SAMEVATTING

Informele nedersettings in die Suid-Afrikaanse konteks is 'n unieke gevolg van Apartheid se ruimtelike beplanning. Oorspronklik in die vooruitsig gestel as nedersettings vir swart arbeiders het hulle 'n tuiste vir baie Suid-Afrikaners geword. Mamelodi was gestig as 'n effektief ontwerpde informele nedersetting vir arbeiders wat werk in Pretoria en het teen 'n eksponensiële koers gegroei wat gelei het tot 'n groot aanvraag vir behuising. 'n Massa voorsiening van behuising was toe en ná 1994 geïmplementeer om hierdie aanvraag te voorsien. Dieselfde strategie van behuising word steeds voortgesit deur die Reconstruction and Development Programme (RDP). Hierdie behuisingsvoorsiening was nog nie aangevul deur 'n voorsiening van openbare geriewe nie en het gelei tot eentonige woonbuurte wat gevul is met behuising en geen openbare ruimte.

Die steeds groeiende gemeenskap van Lusaka, in die ooste van Mamelodi, is 'n gemeenskap met 'n landskap van behuising sonder openbare geriewe en openbare ruimtes. Hierdie woonbuurt het groot getalle mense wat in en uit beweeg, met sommige mense wat dit sien as 'n plek van blywendheid en ander as 'n tydelike ompad. Hierdie instroming van mense en die dualiteit van tydelikheid en blywendheid skep 'n baie dinamiese samelewing, een wat die huidige argitektuur nie op kan reageer nie. Die nuwe argitektuur moet die bogenoemde kwessies aanspreek om die gemeenskap toegang te bied tot openbare geriewe en openbare ruimtes wat waarde toevoeg tot hulle omgewing. Deur dit te doen kan die oplossings wat afgelei is bespreek en gebruik word om soortgelyke kwessies aan te spreek wat informele nedersettings regoor Suid-Afrika teister.

Argitektuur is vir die mense.

TABLE OF CONTENT

1 INTRODUCTION 1

- 1.1 Background
- 1.2 Problem Statement
- 1.3 Hypothesis
- 1.4 Project Intention
- 1.5 Research Question
 - 1.5.1 Sub questions
- 1.6 Research Methodology

2 SITE AND CONTEXT 7

- 2.1 Site
- 2.2 Analysis of Fabric
 - 2.2.1 Movement
 - 2.2.2 The street
 - 2.2.3 Housing
 - 2.2.4 Social /cultural
 - 2.2.5 Architectural

3 FRAMEWORK 23

- 3.1 Mamelodi Urban Framework
- 3.2 Bophelo Precinct Proposal

4 PROGRAMME 39

5 PRECEDENT STUDY 44

- 5.1 Alexandra Interpretation Centre
- 5.2 Outreach Foundation Community Centre
- 5.3 Taxi Rank No.2
- 5.4 VPUU – Violence Prevention through Urban Upgrading_ VPUU Urban Park and Active Box
- 5.5 Koban

6 THEORETICAL APPROACH 55

6.1 Urban public space_ our “Africaness” and our spatial legacy

6.2 Public space_ the good neighbourhood

6.2.1 The African space

6.2.2 The public architecture

6.3 Aspiration in [public] architecture

6.3.1 The vernacular

7 DESIGN DEVELOPMENT 64

7.1 The concept

7.1.1 The programme

7.1.2 Phase 1

7.1.3 Phase 2

7.2 Principles

7.3 Initial design

7.4 Design Iteration

7.5 Final Design

8 TECHNICAL INVESTIGATION 129

8.1 Tectonic Concept

8.2 Technological intention

8.3 Structural intention

8.4 Learning from the context

8.5 Services and sustainability

Technical precedent

8.6 The Structure

8.7 The Panel

8.8 Detail Development

8.9 Final Detailing

Conclusion

9 ADDENDUM 189

9.1 Final Model

9.2 Presentation

9.3 Materials

10 REFERENCES 196

9.1 List of Figures

9.2 Bibliography

1

INTRODUCTION

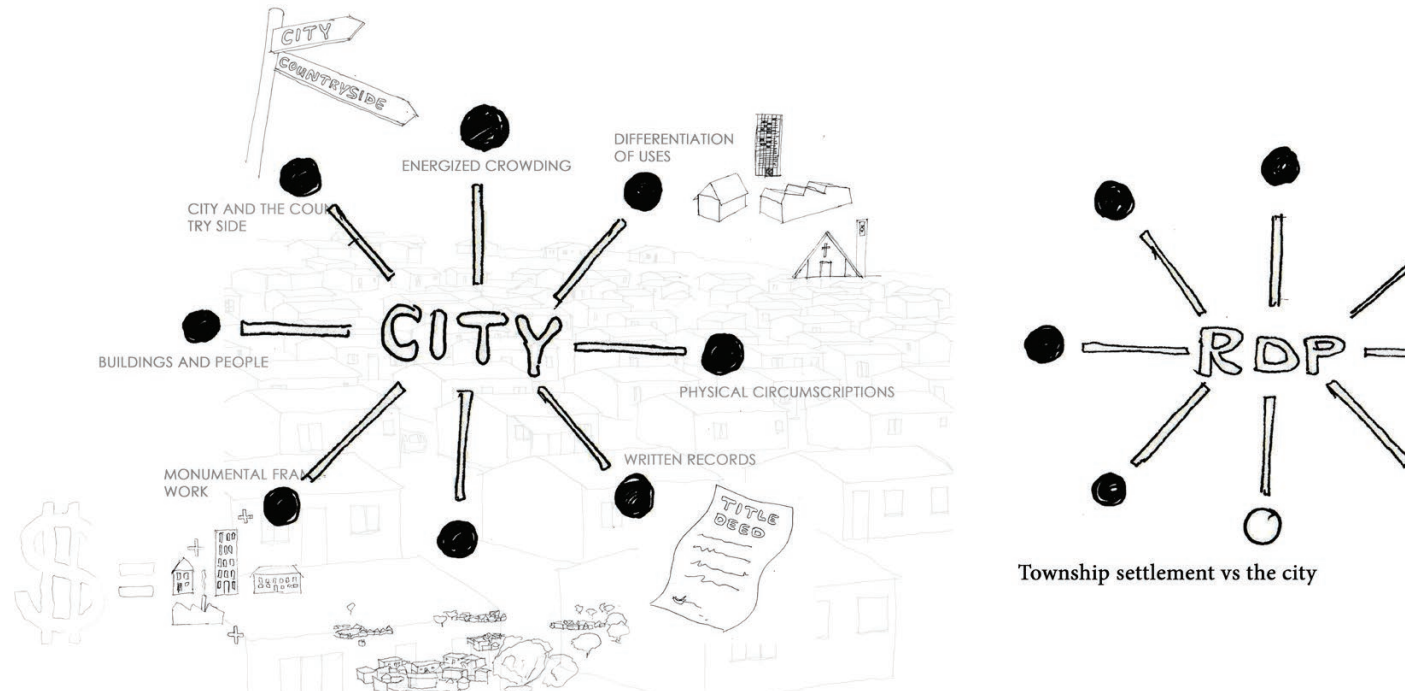

Figure 2: Components that make up a city (Author 2016).

1.1 BACKGROUND

Townships and informal settlements are the neglected parts of South Africa and as such are deprived of the opportunities enjoyed by many developed areas. As the most evident manifest of the Apartheid legacy, the township becomes an opportunity to start subverting the ramifications of the **Apartheid planning legacy**. The insufficient provision of **public amenities** provides an opportunity of engaging these issues to produce new **civic/public precincts** that become a catalyst of the change in townships.

Spiro Kostof's good characteristics of a good city (Kostof 1991: 37-38) highlights principles that make up a well-functioning city. Mamelodi is a township with many net-

works, intersecting and then leaving the settlement, functioning as a city. In eco systemic thinking, a city has many parts and Pretoria is a mechanism, with Mamelodi being one of its smaller gears that can help make the city function better.

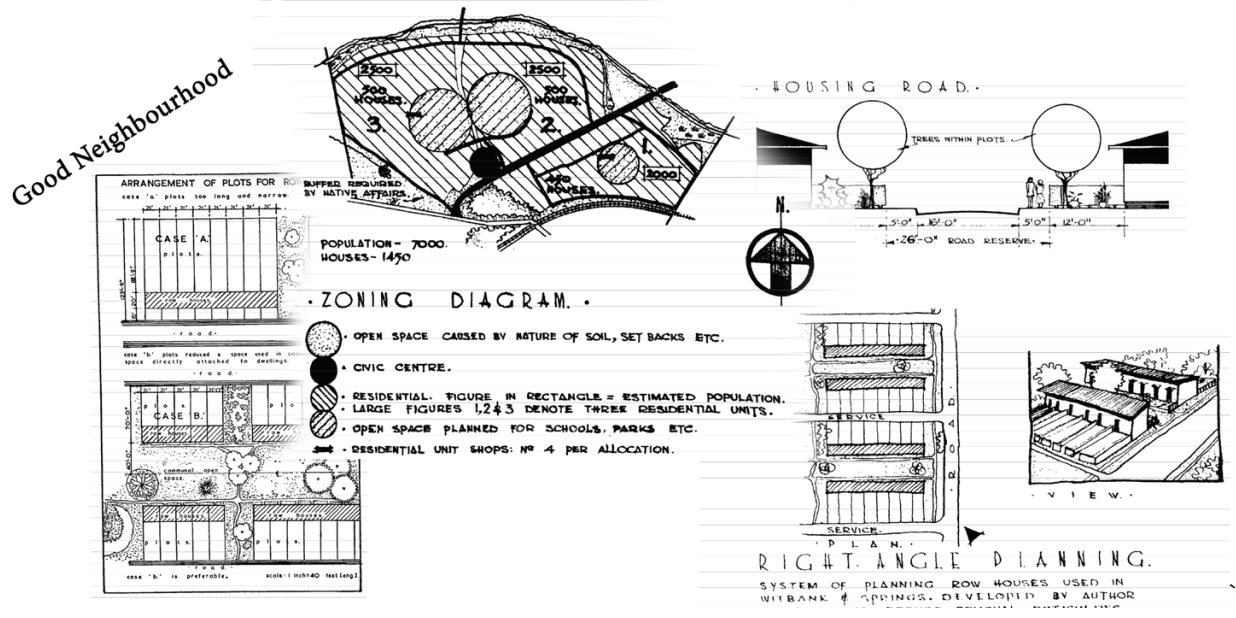

Figure 3: Calderwood's plans of black native townships and the infrastructure required to make it a good neighbourhood (Calderwood 1953).

Calderwood (1953) developed his thesis together with CSIR (Council for Scientific and Industrial Research) for alternative ways for housing black people in townships (See fig.2). When he was researching and analysing various housing typologies for these townships, the house designs were not designed in isolation but as part of functional components including green spaces, public amenities and civic spaces that would make up great neighbourhoods for the natives migrating and living

in these settlements. His research outcomes were then subverted by the National Party of 1948, where only his NE-51/9 was used by the government and implemented at a large scale in townships to create 'Model native township'(Haarhoff 2011: 191).

In the Apartheid Era, the NE-51/9 was the housing typology that was used when many townships were expanding as a cheap option to housing the masses of people needed to be near the city. This same pattern of monotonous residential type of houses still persists in post 1994

South Africa through the RDP (Reconstruction and Development Programme) housing scheme. In These neighbourhoods peoples housing needs are provided for, but the lack of public spaces and amenities make for unsustainable urban areas.



Figure 4: Service Provision Collage (Adapted by Author 2016).

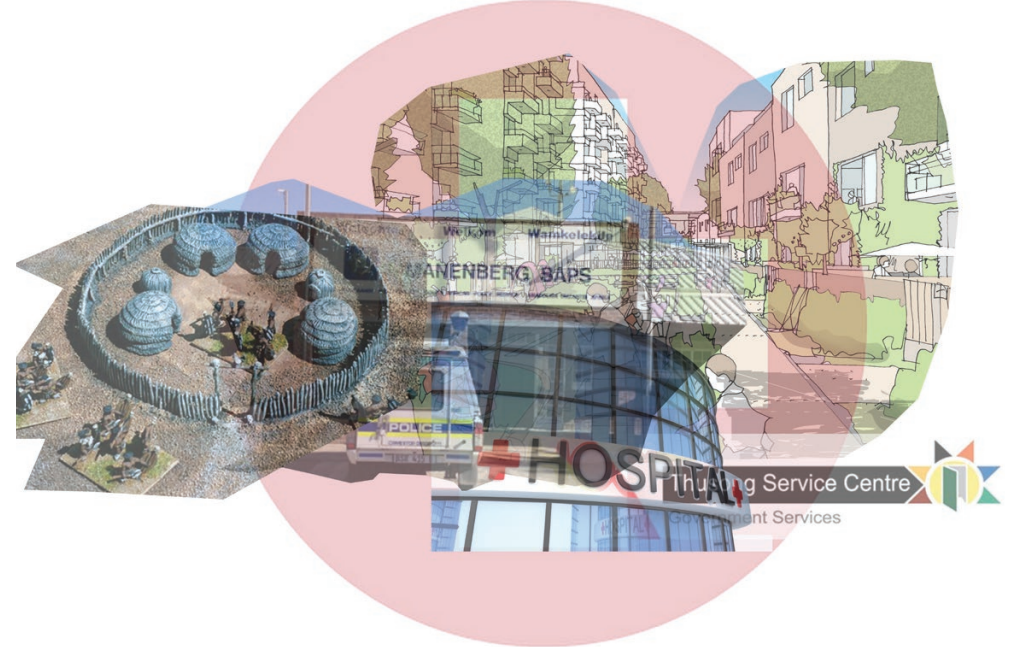

Figure 5: Architectural Intention Collage (Adapted by Author 2016).

1.2 PROBLEM STATEMENT

Social infrastructure, a subset of the infrastructure sector, 'typically includes assets that accommodate social services (New Zealand Social Infrastructure Fund [NZSIF] 2016)' has existed as isolated entities in the built environment. People's access to basic social services has been conceded. People need for public space is also negated and only have their fundamental need of shelter being satisfied.

1.3 HYPOTHESIS

Lusaka is a Reconstruction and Development Programme (RDP) settlement and its massing is made up of social housing with very few **public amenities** and **public spaces**. As a **catalyst** of urban and social change, issues such as monotonous settlement housing pockets, privatisation of public amenities and centralised service provision can be addressed. Architecture has the potential of providing these basic services and also the need for public spaces which are needed for the growing community

1.4 PROJECT INTENTIONS

This dissertation will seek a solution to collaborative working environments between citizens and authoritative and **government entities** that service them. It becomes imperative to foster a different relationship between a community and the people that serve them. The architecture will attempt to answer what a **post-apartheid public and civic space** can be and how it can function to better serve the people who the space is made for.



Figure 6: The intervention as the “in-between” formal and informal (Author 2016).

1.5 RESEARCH QUESTION

How can the provision of public amenities in a highly public interface allow for a different relationship between people of the community and the people who serve them?

What potential does architecture have in creating social cohesion in a Township with both informal and formal settlements which lack sufficient social infrastructure?

1.5.1 Sub Questions

- What is the **civic architectural identity** in our post-apartheid society?
- How to address the multi-layered scales of fragmentation of our environment through **various scales of intervention**?
- How to incorporate a highly authoritative government entity into the **public sphere**?

1.5 RESEARCH METHODOLOGY

Site and context analysis will be performed to uncover:

- o The social networks around the site and to get a better understanding of them.
- o A better understanding of the use of public spaces currently to know how to intervene appropriately without introducing an alien concept

Precedents studies comprising of South African examples of civic and public infrastructure will follow. They will be critically

analysed to understand their underlying principles to see where they succeeded or failed. International examples will also be looked at to better understand how such topics have been tackled in communities with similar challenges.

A study of programmatic relationships between public amenities will be conducted to understand which public amenities are complimentary. These will form the programme for the project.

2

SITE AND CONTEXT

Mamelodi was established as a black native township in 1945. The project site is located in Mamelodi, a township located on the east of Pretoria. Mamelodi had a humble beginning with only 16 houses to support the then new factory of Eerste Fabrieke. This township has grown to become one of South Africa's largest townships (GAPP 2010: 149). Mamelodi like many townships has had a massive need for housing. In 1948 when the National Party was governing the country they supplied many townships similar to Mamelodi with large mass housing known as the NE-51/9 House prototype (figure 7).

These NE-51/9 houses are mostly found in the west side of Mamelodi, where the township was first established. The township started to grow but because of the industrial buffer zones of Watloo and Silverton on the west, the settlement went eastwards towards the Magaliesburg ridge. The settlement continued to grow towards the east past the Pienaars River, which is the divider of Mamelodi East and West.



Figure 7:NE 51/9 House developed by the CSIR (Author 2016).

The exponential growth Mamelodi experienced led to its rapid growth towards the east which the government could not keep up with. The result of this is a great number of informal settlements located on the east and northern edges of the township. This large influx of immigrants was caused by the proximity of Mamelodi to Pretoria CBD. Much like many townships located on the peripheries of the city, Mamelodi acts as a gateway for those seeking refuge and employment in the city.

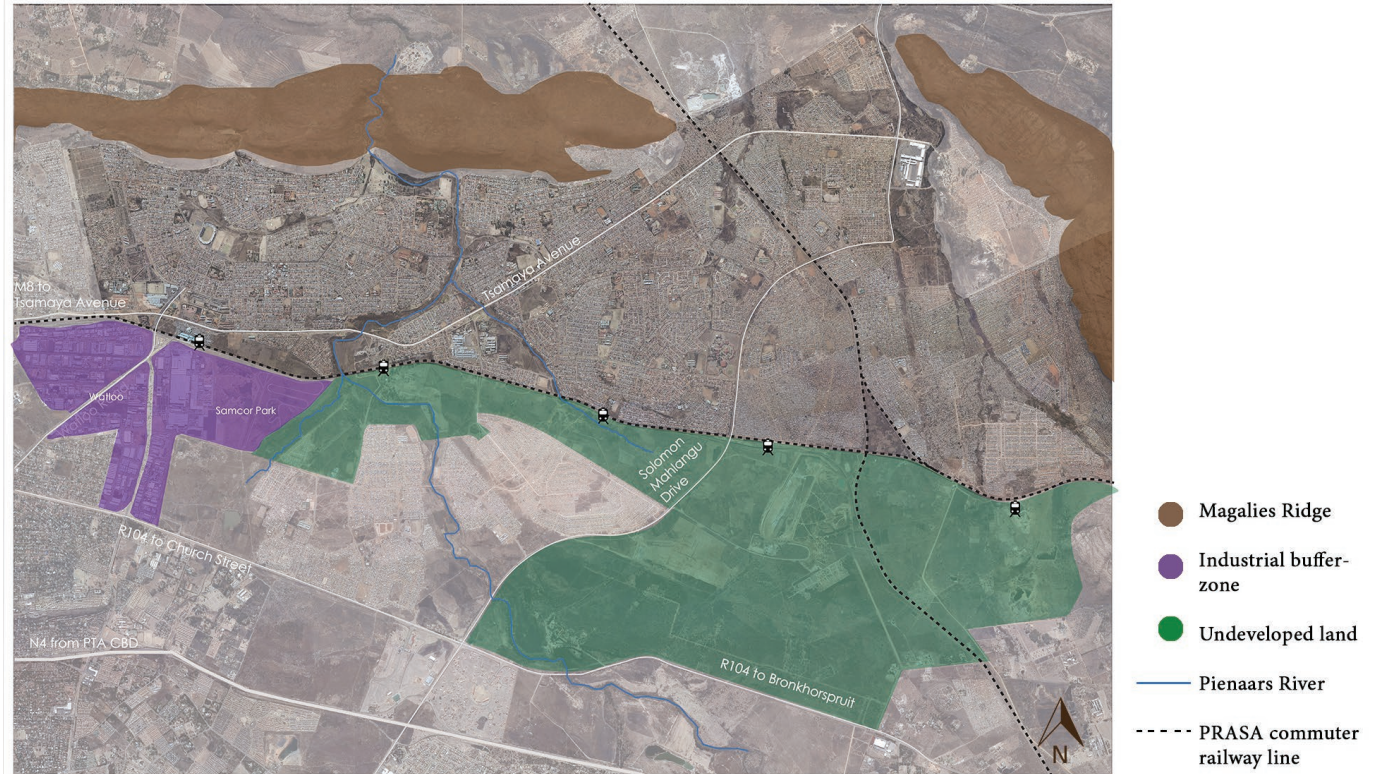

Figure 8: Buffer zones that define Mamelodi (Author 2016).

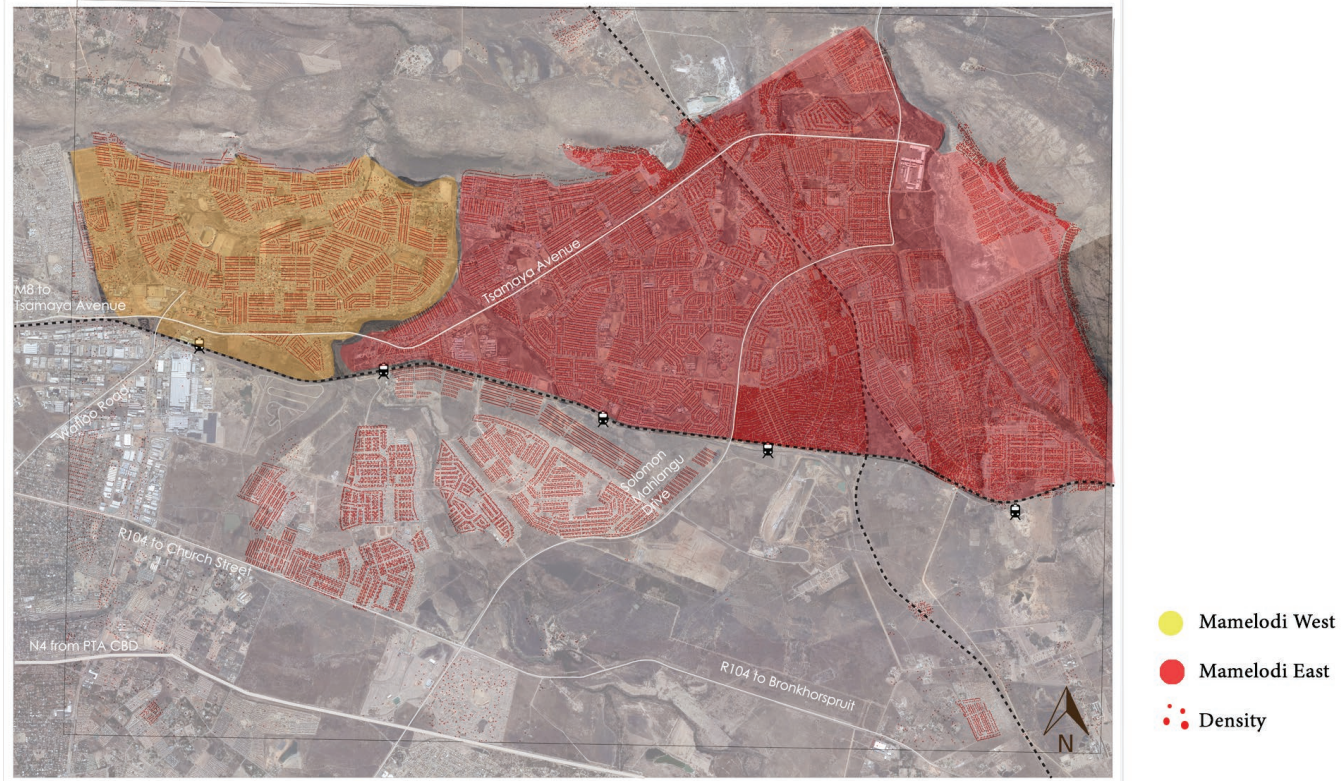

Figure 9: Density map (Author 2016).

Mamelodi grew steadily towards the east but after 1994. It grew rapidly in the east and this is where most informal settlements are located, as shown in the housing diagram, figure 10. As it is, the east is the densest portion of Mamelodi (see figure 9).

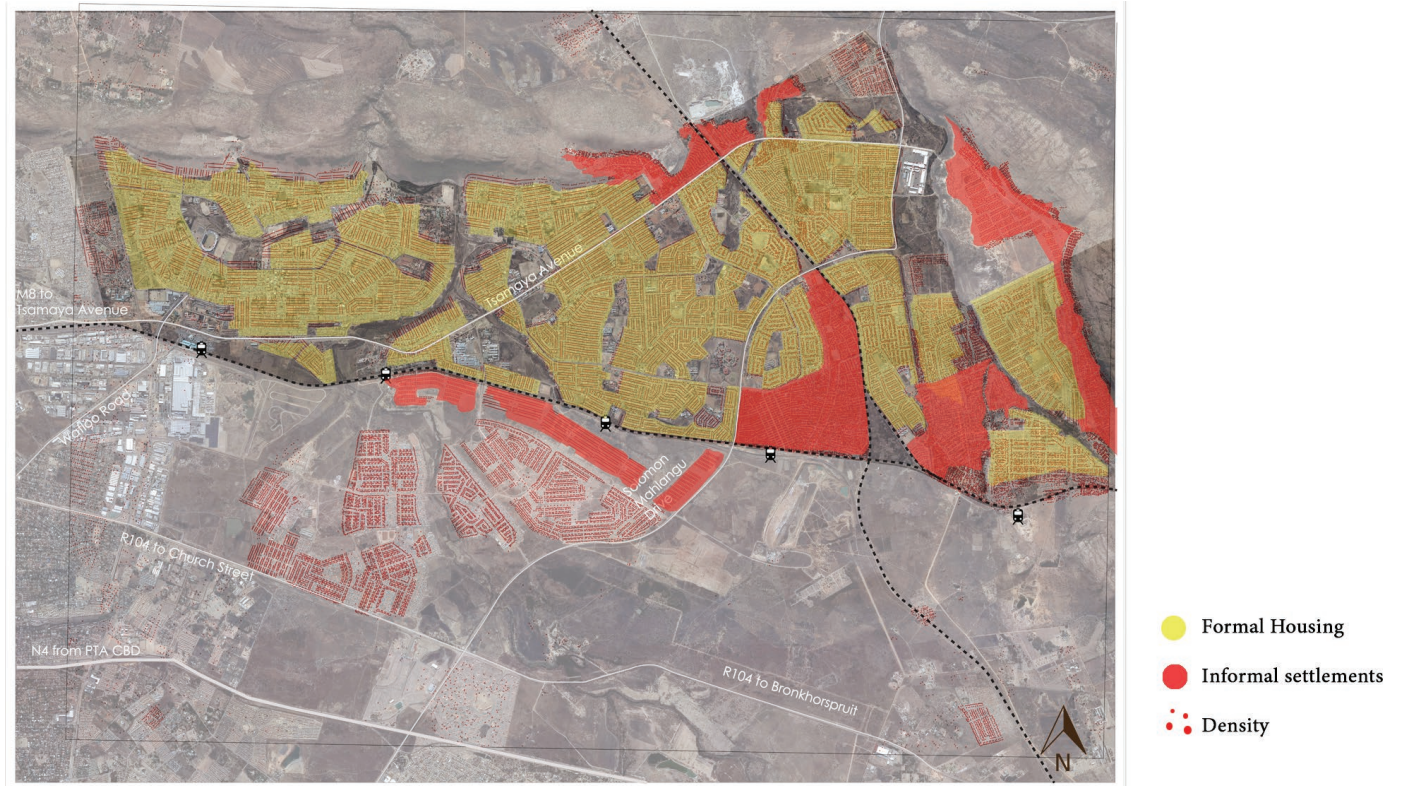

Figure 10: Formal and informal housing (Author 2016).

Post 1994 housing provision came by the Reconstructive Development Programme (RDP) introduced by the government to try and keep up with the housing needs of the community through subsidised housing. This was to cater for settlements established pre 1994 and then later those established post 1994. The programme led to the provision of mass housing schemes carried out in multiple phases across the east of Mamelodi. But unlike the provision of housing during the Apartheid era, the current provision of housing has not been supplemented by the provision of infrastructure networks to help support the growing township. The types of infrastructure that the township would need would be water and sewerage, energy and communication, roads and transportation, economic infrastructure and **public infrastructure**.

Public service infrastructure is well provided for in the west side but towards the east, it becomes less effective due to a larger population and a lack of investment into social infrastructure and more into housing. The provision of public or social infrastructure creates to a varied fabric in Mamelodi. As shown in the public amenities map, figure 11, Mamelodi west is well catered for in terms of the extent of the settlement and the number of public amenities. Mamelodi east is under serviced being the larger settlement with fewer amenities. Eastwards of the settlement there is more inadequate the provision of these services. Access to these basic services, that a community needs to grow, has been delimited and thereby reducing the quality of life that the community may have.

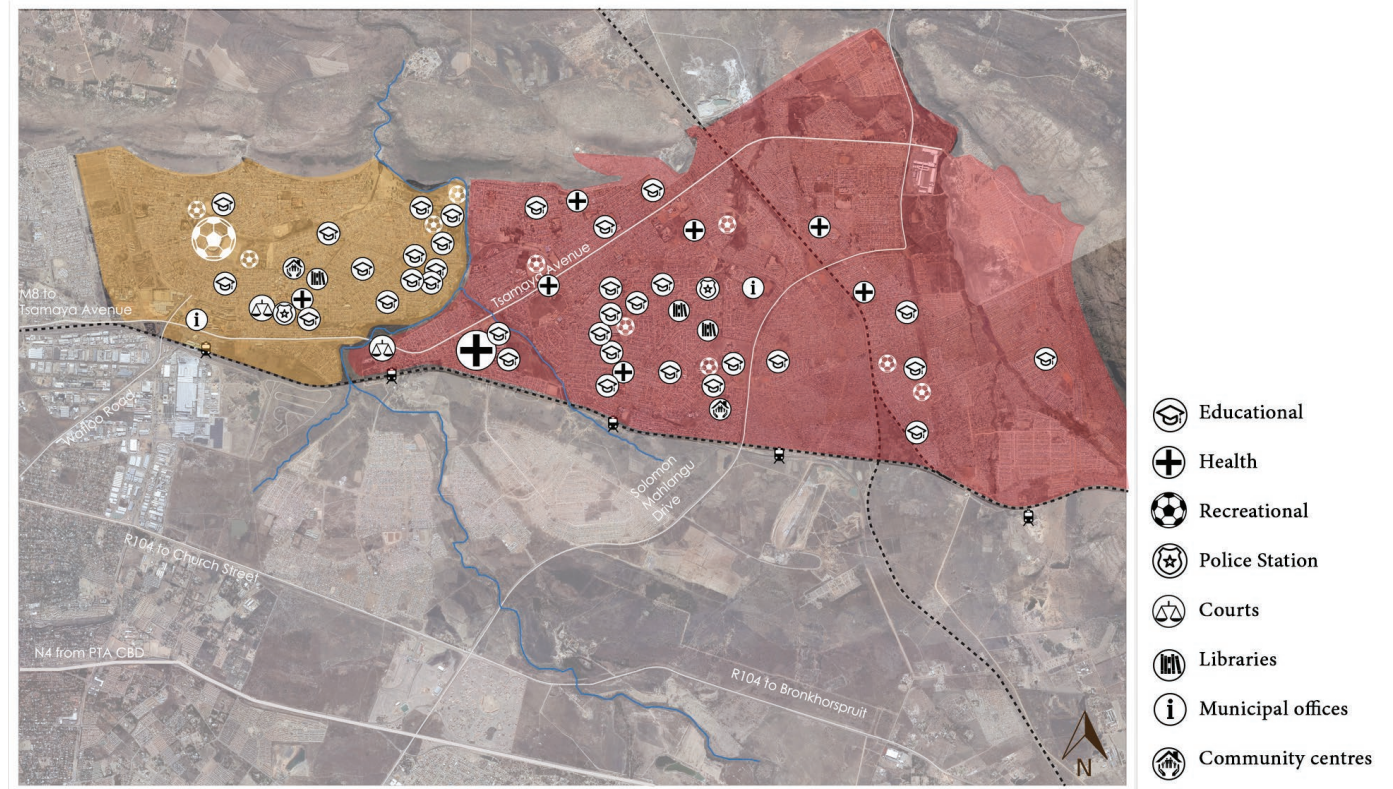

Figure 11: Public Amenities in Mamelodi (Author 2016).

2.1 SITE

The area of intervention is located in the Lusaka settlement (see figure 12). The settlement is located to the east of Mamelodi. It forms part of ward 10 and ward 97 of the City of Tshwane. The settlement is defined by Solomon Mahlangu drive on the northern edge and the commuter railway line on the South. On those two edges there is a large transport bus and taxi interchange on Solomon Mahlangu drive and the Pienaarspoort Train Station on the south. Hector Peterson Dr connects the site to Solomon Mahlangu drive and the greater extents of Lusaka to the east and the informal settlement of Alaska on the east periphery of the township.



Figure 12: Site location and extent of reach of the intervention (Author 2016).

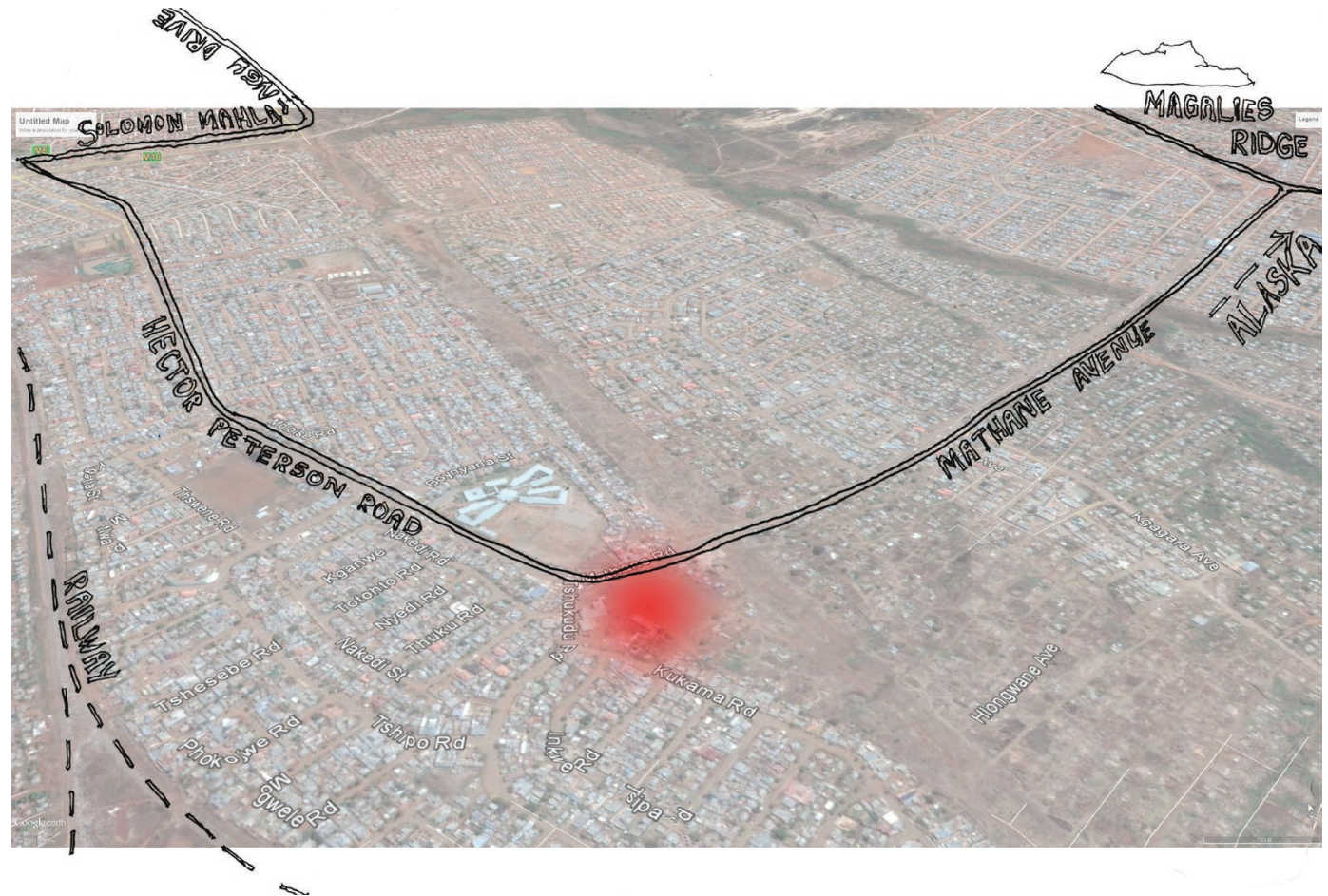

Figure 13: Site edges and constraints (Author 2016).

Lusaka is one of the first phases of the RDP housing scheme and as a result, it is made up of mass housing. Due to the high demand of housing at the time, the Lusaka also plays host to a number of informal dwellings. As a result, the settlement has a very peculiar character. This character can be summarised as a duality. The duality between the formal and informal, **permanence and temporality**.

2.2 ANALYSIS OF FABRIC

The dualities experienced in Lusaka leads to it being a very dynamic environment.

2.2.1 Movement

The highest frequency of movement on the site is along Hector Peterson Dr. This includes both vehicular and pedestrian traffic. This due to the aforementioned transport nodes located on the northern and southern borders. There is also north to south movement and this secondary movement is predominantly pedestrian traffic moving in the smaller residential pockets along and across Hector Peterson Dr. Mathane Ave. into other neighbourhoods



Figure 14: Energy flow and movement of people and vehicles (Author 2016).

2.2.2 The Street

Hector Peterson drive is the main road in the settlement and as such it allows for a vast amount of activities due to the high vehicular and pedestrian. The street edges can be characterised as a **linear public space** with various economic activities such as formal and informal trading, food stalls, welding and cabinet making and such like.

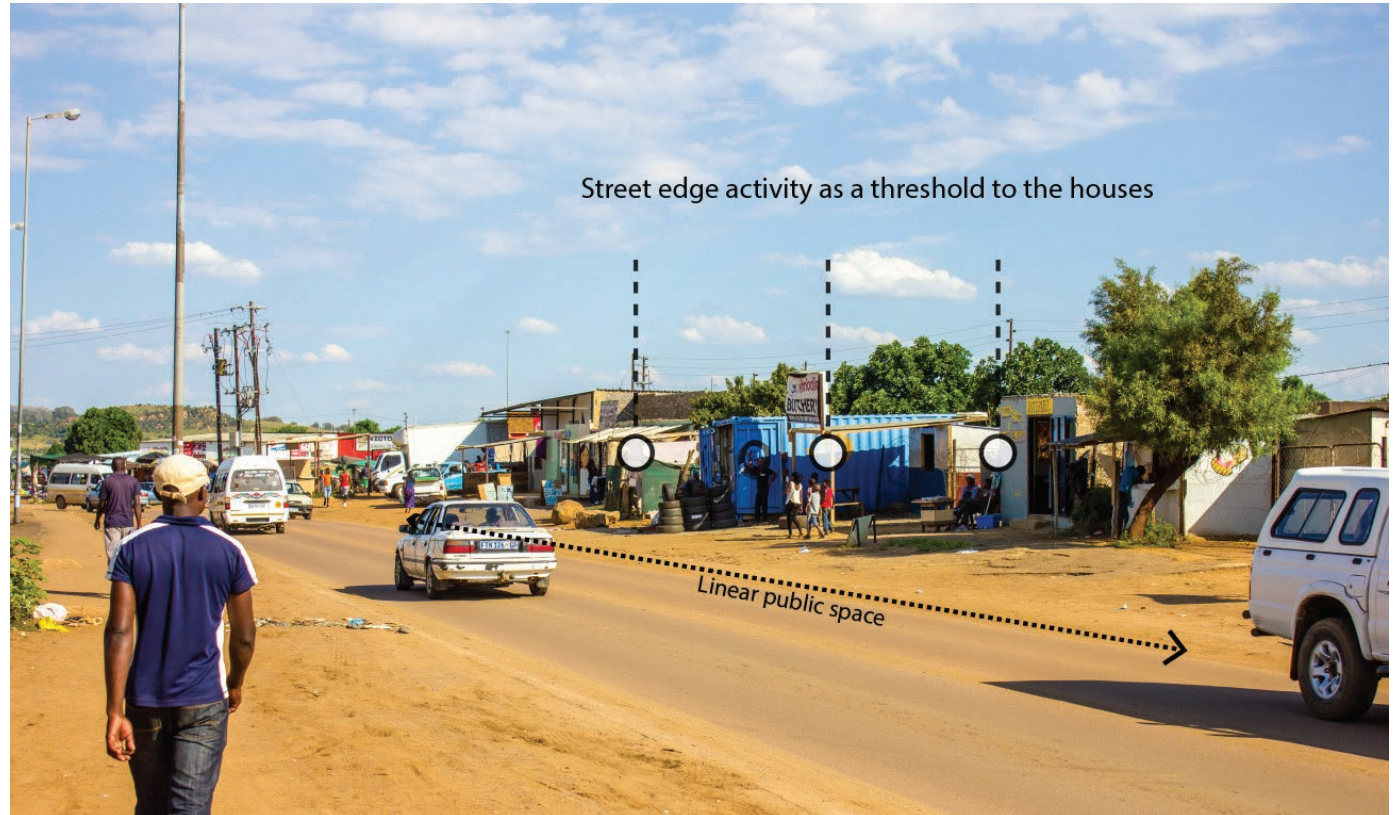

Figure 15: The street as a public space (Author 2016).

2.2.3 Housing

Lusaka is made up mostly of RDP houses of various phases. Small pockets of informal settlements are found around Lusaka. New shacks are still being erected across the Lusaka because of the open land around Lusaka and because Lusaka is better connected to the rest of Mamelodi as opposed to Alaska informal settlement found along the Magaliesburg Ridge. Most of the shacks located in and around Lusaka been around for years as some have been identified and recognised by the municipality and given permanent status.



Figure 16: Shacks that are marked and recognised by the municipality (Author 2016).

2.2.4 Social /cultural

Religion seems to be an important component in the lives of the community as you find varied religious denomination along the main road and even deeper in Lusaka. Recreational activities also form part of their lives. These include recreational spaces provided by the school such as the sports fields found in Meetse a Bophelo Primary School but also open lots where the public plays soccer. Some of the opens lots even belong to sports clubs such a Victory Soccer Field.



Figure 17: One of few recreational spaces and religious building (Author 2016).

2.2.5 Architectural

Formal and informal, permanence and temporality, as characteristics of Lusaka, play an important role in defining the architectural character of the site. It is a mixture of organised growth and organic growth. Additions to existing house also vary in form, some are of the same architectural language and some are in complete contrast.

The architectural language varies from Tuscan styled houses to you simple shack dwelling. The guiding principles that seem to determine the building language is the amount of money the home owner has, their **aspiration** levels, spatial constraints and whether they see Lusaka as a place of permanence or a transitory place.



Figure 18: Movement and energy flow across the site (Hector Peterson Road (Author 2016).



Figure 19: Commercial edges of the site (Tshukudu Street) (Author 2016).



Figure 20: Architectural language as signs of aspiration (Author 2016).

3 FRAMEWORK

MAMELODI URBANFRAMEWORK

Mamelodi a township located on the east of Pretoria. It was founded in 1945 as a black native township with workers stationed at Eerste Fabrieke. The township has grown steadily and is one of the biggest townships in Pretoria. Like many other townships, Mamelodi has been plagued by Apartheid spatial planning and as a result, the township is located 25km from Pretoria CBD. It is far removed from the financial and economic opportunities available in Pretoria. Even with this spatial disadvantage, Mamelodi is still the first port of arrival for those that are seeking employment and residency in Pretoria (Mahlangu et al. 2016)..

Everyday a large number of people make their way out of Pretoria and towards the city. This leaves the township without much energy. This energy has been recognised as an energy that, if kept in the township, will help grow Mamelodi into a self-sustaining entity, an entity that once that can contribute to Pretoria in a positive way (Mahlangu et al. 2016).

The broad objectives of this urban framework are rooted in the creation of opportunity within the context of Mamelodi, through the above-mentioned pointers as a guide. The generation of opportunity will be ensured by the integration of all the cells that make up the greater Mamelodi as a whole. Cells of social and economic opportunity will provide access to many physical and social resources that will result in the reduced dependency on the CBD.

Through understanding the energy that leaves Mamelodi on a daily basis through the daily exodus of people going to work in the CBD and other surrounding areas we have come up with a proposal to channel this energy back into Mamelodi. We begin to view Mamelodi as this cell that consists of various smaller cells that all work together in creating energy and opportunity in Mamelodi.

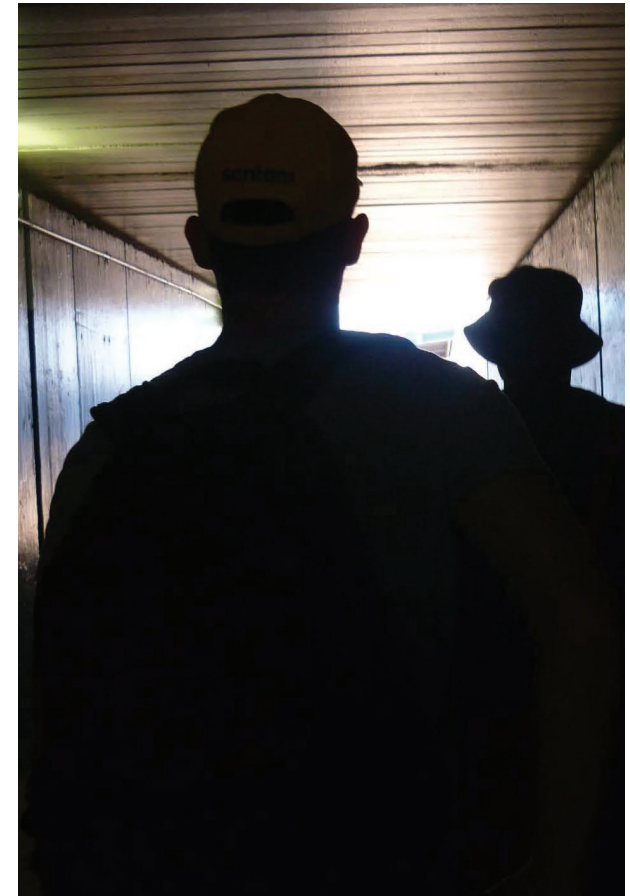

Figure 21: The daily exodus (Mahlangu et al. 2016).



Figure 22: Existing and proposed urban cores (Mahlangu et al. 2016).

The initial step is identifying Mamelodi's urban core, Denneboom, and then proposing two more urban hubs (Mahube Max City Mall and Greenview train station), creating a triangle around the township. These cores are linked by Tsayama Road, which is the major road run east to west through Mamelodi, the commuter railway line and Solomon Mahlangu Drive which is the road into the east of Mamelodi (Figure 22).



Figure 23: Primary nodes (Mahlangu et al. 2016).

The second step is identifying primary energy nodes, which have been identified as the train stations running on the southern edge of Mamelodi as shown in Figure 23. These train stations transport people and good throughout Mamelodi and then out towards the city.

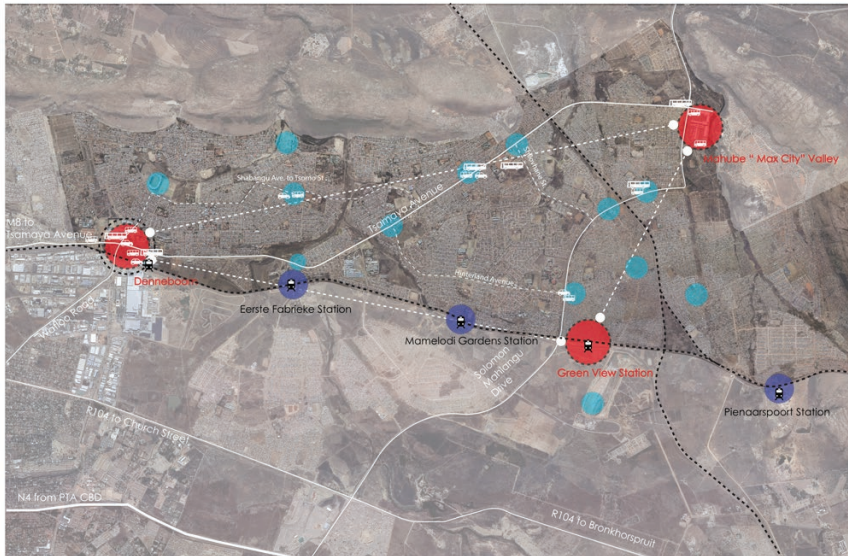

Figure 24: Secondary nodes (Mahlangu et al. 2016).

These primary nodes are then supplemented by the secondary nodes, which are public transport interchanges within the townships. These nodes are located in both the east and west of Mamelodi (figure 24).

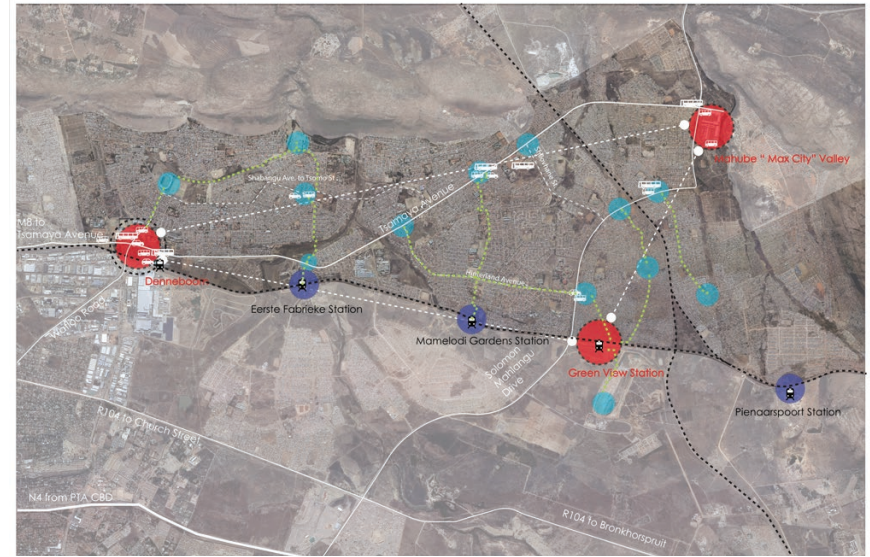

Figure 25: Activity spines connecting nodes (Mahlangu et al. 2016).

In order to achieve a greater distribution of energy within Mamelodi, the existing east to west movement will be disrupted by the implementing of north to south movement of people and goods through the activity spines we have proposed (figure 25).



MAHLANGU • WOLMARANS



BOPHELO PRECINCT PROPOSAL



Figure 29: Existing attributes of Lusaka and the proposed precinct location (Mahlangu & Wolmarans 2016).

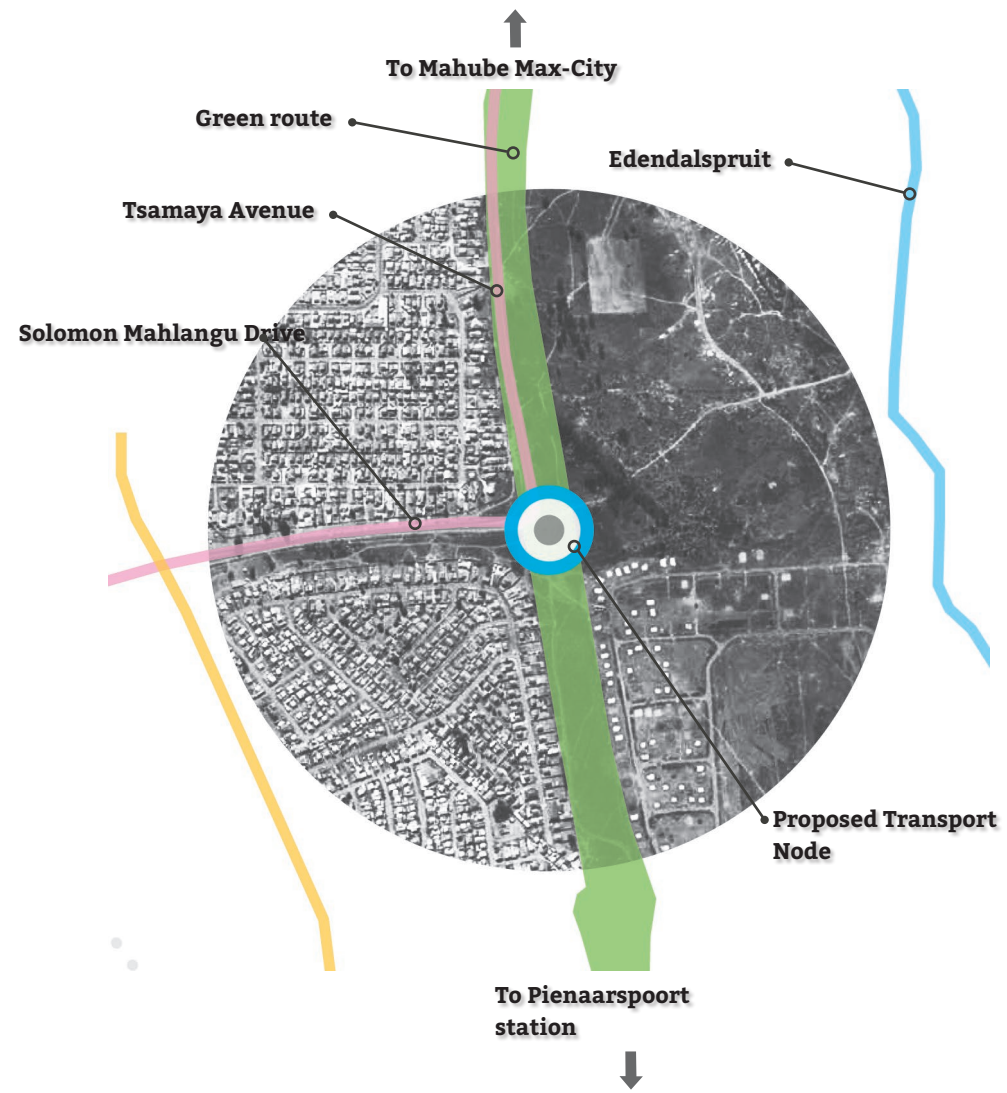

Figure 28: Proposed Urban Hub, Mahube Max City Mall, Mamelodi (Mahlangu & Wolmarans 2016)

MAHUBE PRECINCT

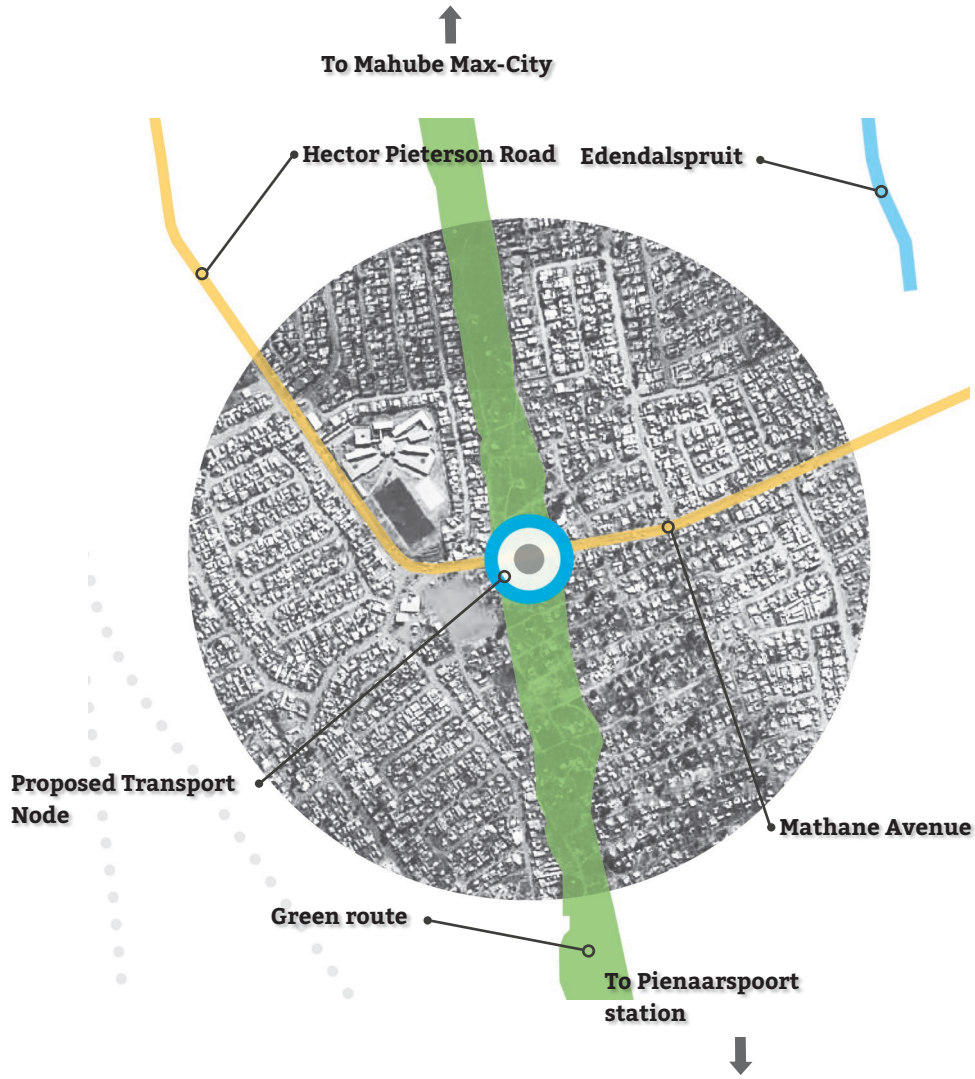

Figure 31: Points of interests and nodes linked to Bophelo Precinct (Mahlangu & Wolmarans 2016)

BOPHELO PRECINCT

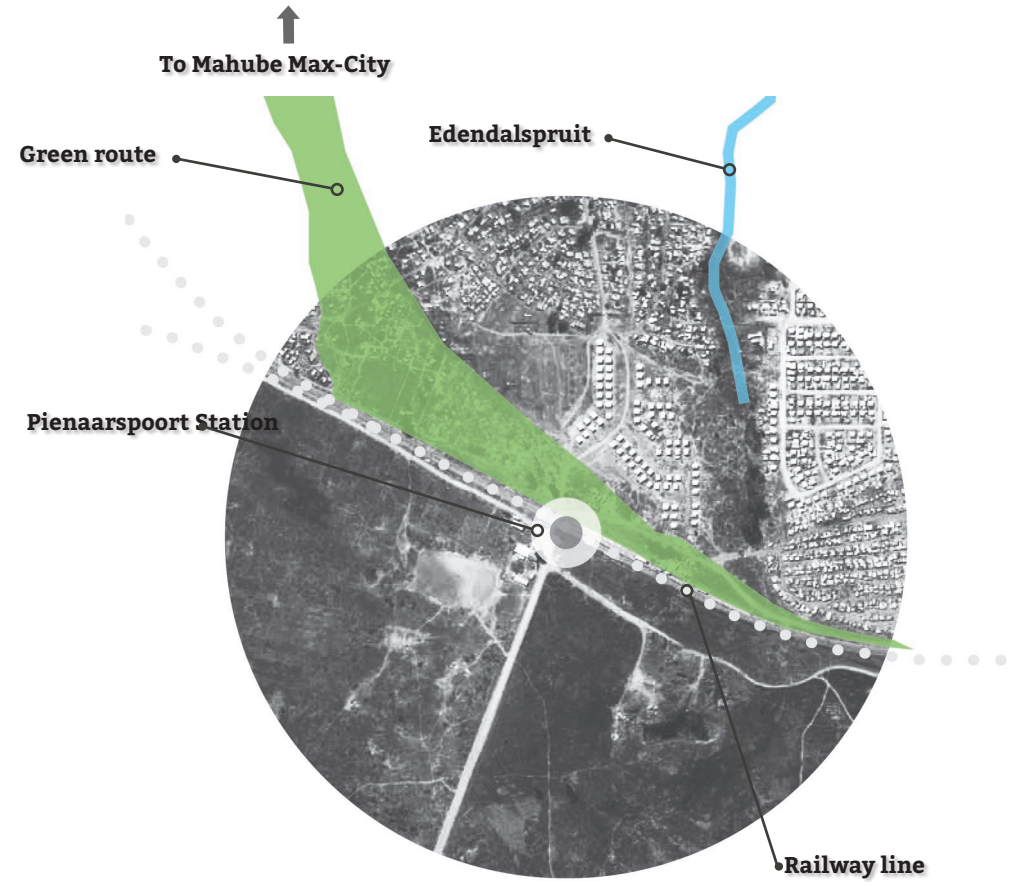

Figure 30: Points of interest around Pienaarspoort Train Station (Mahlangu & Wolmarans 2016)

PIENAARSPOORT PRECINCT



Figure 33: Pedestrian movement around the precinct where the best suited interventions will be implemented (Mahlangu & Wolmarans 2016)

EXISTING ROUTES



Figure 32: Existing zones of interest. This will be incorporated in the precinct proposal with various interventions (Mahlangu & Wolmarans 2016).

EXISTING ZONES



Figure 35: Proposed activities and interventions for the green route (Mahlangu & Wolmarans 2016).

PROPOSED GREENROUTE

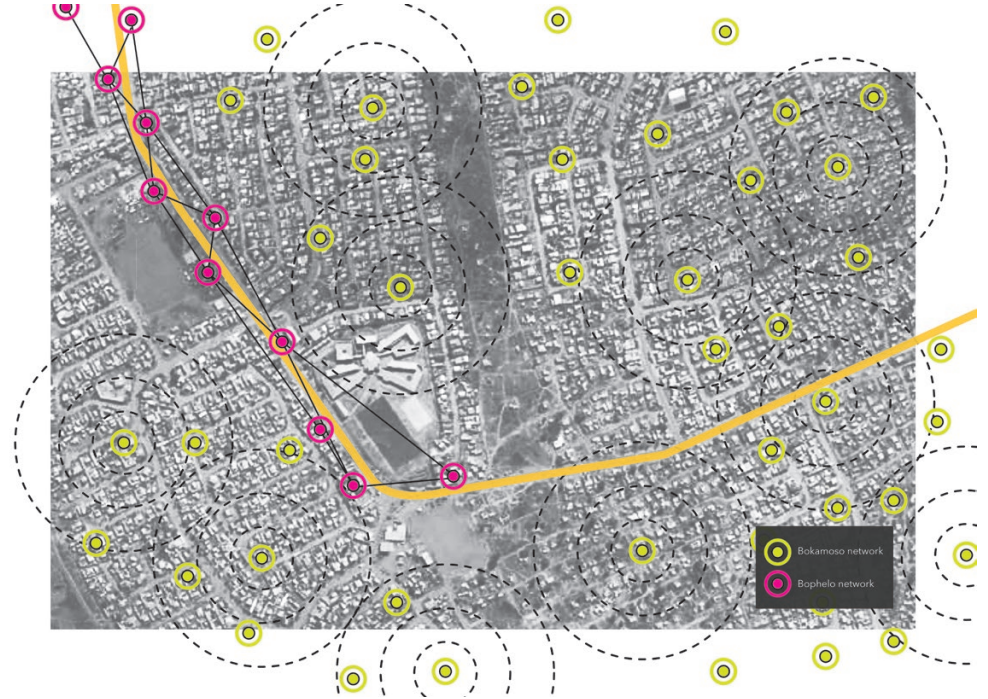

Figure 34: Proposed networks that will supplement the larger civic proposal that form part of the precinct plan (Mahlangu & Wolmarans 2016).

PROPOSED NETWORKS



Figure 37: Network diagram of nodes linked by activity spine (Mahlangu & Wolmarans 2016).

PROPOSED NODES + CONNECTIONS

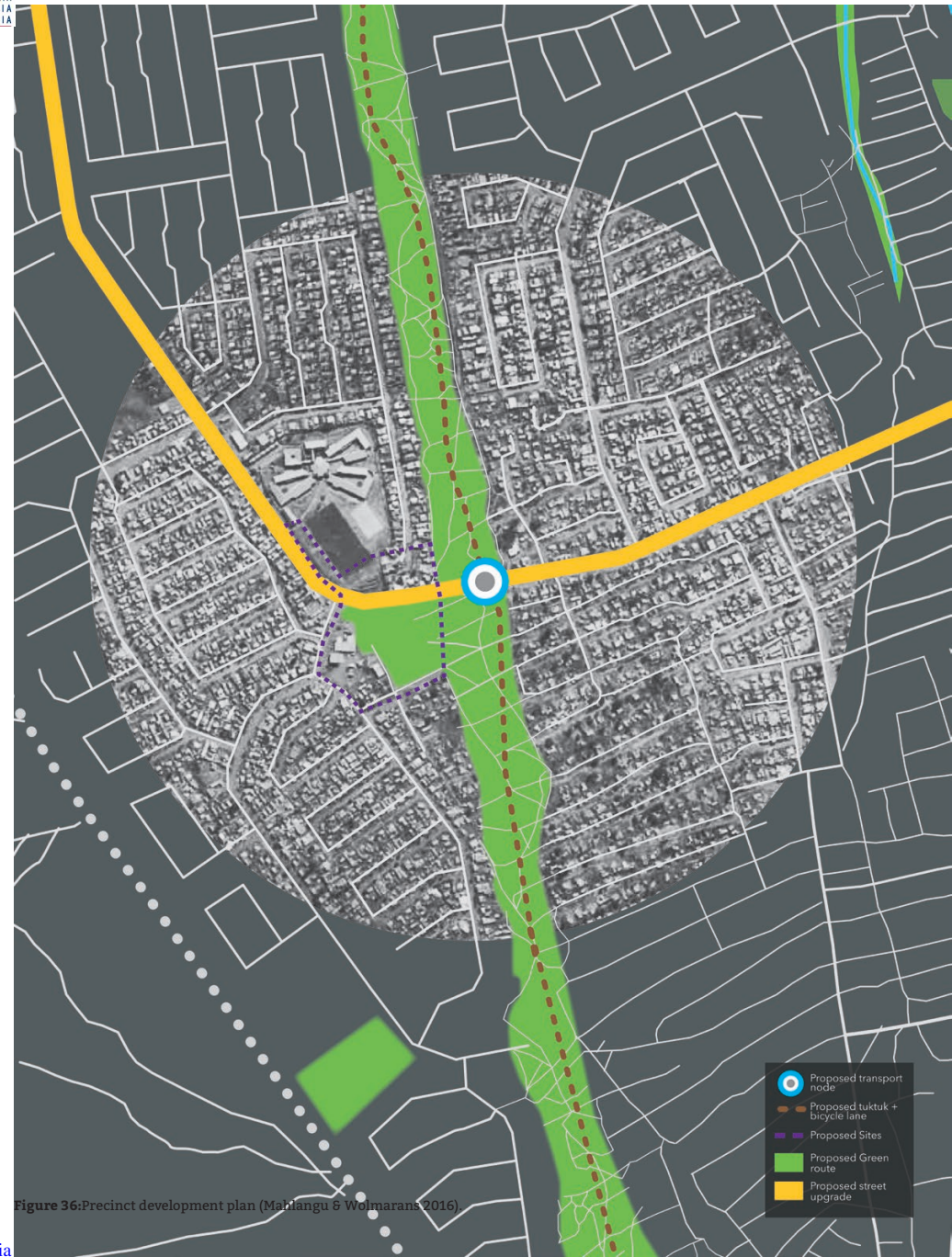
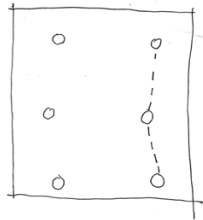
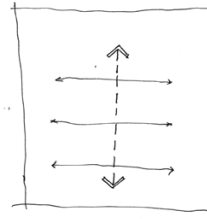

Figure 36: Precinct development plan (Mahlangu & Wolmarans 2016).



1. Improve connection between the nodes

The connection between an urban core (Mahube Max-City mall); the public transport interchange on corner of Hector Peterson road and Solomon Mahlangu Drive.; and Pienaarspoort train station. This is to strengthen the north to south axis within Mamelodi.



4. Connect existing east - west axis with a new north - south axis.

Movement of people and goods moves on an east - west axis. The green route and additional nodal activation strategies aim to fulfil a movement across the north - south axis to create a better network within Mamelodi.

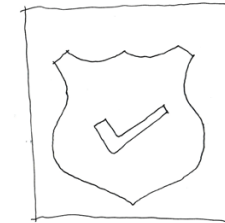

7. Improve safety within community

By improving the networks and relationships within Lusaka, there is an opportunity to improve the social cohesion and by doing that, a more healthier and more secure environment is created for the community

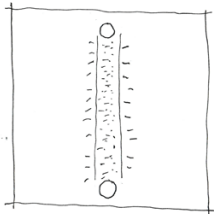

2. Activate the "green route"

The green route is an import route linking the various transport nodes to the urban core. The green route becomes a pedestrian route which will be activated at various points with commercial, agricultural and recreational activities. It also becomes a catalyst of reactivating green spaces in the community.



5. Upgrading street edge

The street is identified as a valuable and contested space. The street becomes a catalyst to greater urban change through identifying the street as a valuable element in the community and then upgrading these edges.

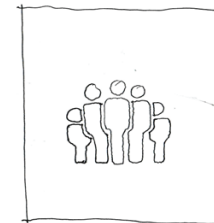

8. Increase access to public amenities

Public amenities are located far away from Lusaka thereby decreasing their access to basic services that a community needs. By increasing the access to these services, the community is better served and their right to the basic public services is addressed.



3. Promote pedestrian + cyclist movement

The public amenities, economical opportunities and public transports hubs within Mamelodi are far away from Lusaka. These social infrastructures will be implemented in Lusaka to give better access to these facilities and help promote a pedestrian oriented community.

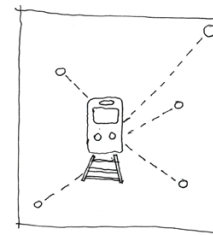

6. Improve access to public transport nodes

Public transport is an important component within the community as it connects them to the rest of Mamelodi and the city of Pretoria.

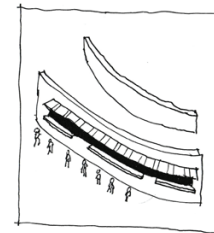

9. Improve the market edge

The street edge and the commercial activity identified in the main streets of Lusaka is an important element and presents an opportunity of identifying the informal market as an element of the culture of the community.

Figure 38: Summary block of development interventions (Mahlangu & Wolmarans 2016).

4 PROGRAMME

The CSIR compiled guidelines for human settlement planning and cited the importance of public amenities as they are the basic services for residential settlements (CSIR 2009: 1) These public amenities are there to serve the needs of individuals and communities, specifically “safety and security, communication, recreation, sports, education, health, public administration, cultural and social” (CSIR 2009: 1).

There are various types of public amenities and they all fall into one of four categories (CSIR 2009):

1. High order public facilities.

These amenities serve large metropolitan areas or city. Examples: university or hospital. These amenities aren’t planned together with residential settlements but as part of a development framework (CSIR 2009).

2. Middle order public facilities

These facilities serve a number of communities and are quite vital to the planning of a residential development. That is not to say they will only serve a single settlement. Examples: high schools, clinics (CSIR 2009).

3. Low order public facilities

These facilities serve a limited number of residential communities and they form part of a residential development. Examples: preschools, crèches (CSIR 2009).

4. Mobile facilities

These facilities move from one community to another to be able to serve a large number of people by bridging the gap to access to some of these facilities. Examples: clinics, post offices, libraries (CSIR 2009).

As part of this dissertation, middle order facilities will be prioritized as well as the decentralizing of some high order facilities will be considered. Public amenities are split into the following facilities (see figure 39 & 40):

- Educational facilities
- Health facilities
- Recreational facilities
- Cultural facilities
- Administrative facilities

Table 5.5.1: Functional categories of public facilities		
FUNCTIONAL CATEGORY OF PUBLIC FACILITY	NATURE OF FACILITY	PROVISION: PUBLIC OR PRIVATE
Educational facilities		
Crèche/nursery school	Local/middle order	Generally privately provided
Primary school	Local/middle order	Generally public provided, but may be private
Secondary school	Middle order	Generally public provided, but may be private
Tertiary facilities (colleges, technikons and universities)	Higher order	Generally publicly provided
Adult learning centres	Middle order	Generally public provided, but may be communal
Health facilities		
Mobile clinics	Mobile	Publicly provided
Clinics	Middle order	Publicly and privately provided
Hospitals	Higher order	Publicly and privately provided
Recreational facilities		
Playgrounds	Lower/middle order	Publicly provided
Sports fields	Middle order	Publicly provided
Sports clubs	Middle order	Usually privately provided
Sports stadiums	Higher order	Publicly provided
Cultural facilities		
Libraries	Middle order	Publicly provided
Community centres	Lower/middle order	Publicly provided
Religious centres (churches, synagogues, mosques, etc.)	Lower/middle order	Privately provided
Administrative facilities		
Cemeteries	Middle order	Publicly provided
Magistrate’s court	Higher order	Publicly provided

Figure 39: Functional categories of public facilities (CSIR 2009: 2).

There are qualitative guidelines that can be used when designing public facilities. They form a basis for urban planning in terms of organising public facilities to make them the effective to satisfy the needs of the public (CSIR 2009: 6):

The principle of reinforcement

- Public amenities should be located close to public spaces. The relationships between these elements will create a distinct urban form that the community can identify.
- Public amenities can be used to define hard open spaces to provide a sense of security due to providing passive surveillance and definition of these spaces.
- High and middle order facilities should be located in prominent positions relative to open space and movement systems (Vehicular / Pedestrian). This will help strengthen their importance within the settlement.
- Clustering public facilities has the advantage of having a large number of people utilising these facilities by accommodating a range of services.

The principle of continuity

- Soft open public spaces should be linked to create a network of recreational spaces that can be supported by public space.
- “A diverse and continuous network of multifunctional open and flexible movement routes should weave through settlement systems and connect public facilities” (CSIR 2009: 6).
- Public services that aim to serve multiple communities should be located along major transport routes enabling easier access to these services.

Table 5.5.1: Functional categories of public facilities (continued)		
FUNCTIONAL CATEGORY OF PUBLIC FACILITY	NATURE OF FACILITY	PROVISION: PUBLIC OR PRIVATE
Administrative facilities (continued)		
Municipal offices/pay points	Middle order	Publicly provided
Post offices	Middle order	Publicly provided
Police stations	Middle order	Publicly provided
Fire stations	Middle/higher order	Publicly provided
Old age homes	Middle order	Publicly provided
Children's home	Higher order	Publicly provided
Information centres	Middle order	Publicly provided

Figure 40: Functional categories of public facilities (CSIR 2009: 2).

The principle of discontinuity

- “Higher-order and middle-order public facilities should be located on stop-start activity streets, in order to create thresholds high enough to support facilities and also ensure that the people can gain direct and easy access to facilities” (CSIR 2009: 6).
- Public spaces and facilities can be used to create areas of intense activity thereby creating spaces that can range from public to private. These create a variety within the urban fabric creating diversity within the settlements.

The principle of externalisation

- Public facilities should be located in a position that allows the facility to be exposed to the public. This allows the public space and facility to be an enabler of cohesion and integration between various residential settlements.
- “The clustering and sharing of facilities is not only more efficient but can also have a positive impact on development, as it creates potential sites for local business and generates more concentrated activity and travel patterns” (CSIR 2009: 6).

The principle of hierarchical concentration along major routes

Public facilities serve different purposes and therefore the location of a public facility will depend on the specific function that it performs (CSIR 2009: 7):

- Public facilities that distribute emergency vehicles (ambulances, fire engines, etc) should be located on primary movement routes so that access by such vehicle is easier and faster. This will allow for faster service provision to the public.
- Public facilities need to be accessible and visible to get maximum exposure to the public. This should be through various movement systems such as public transport or vehicular as well as through pedestrians. This means these facilities have to be safe and secure have easy access to households.

The principle of hierarchical association of public space and public facilities

Public amenities can be used as elements that are able to create link within mix land use environments. They become social spaces that the public can gather in and use. Public facilities can be divided into 2 groups (CSIR 2009: 7):

- Homogenous facilities: Very local in nature and serve a particular community. Examples: A church / crèche.
- Heterogeneous facilities: Serve a variety of communities and can be found in locations accessible by the greatest number of people.

An investigation was then done to establish which facilities are needed in a residential settlement and which ones are absent in Lusaka as seen in figure 41.



Figure 41: Programme (Author 2016).

5 PRECEDENT STUDY

5.1 ALEXANDRA INTERPRETATION CENTRE

Architect: Peter Rich Architects
Location: Alexandra, Johannesburg
Project Year: 2003

Precedent_ [Functional / material / technology]

The project is located in Alexandra, one of South Africa's poorest townships. The project aims to celebrate Nelson Mandela, in his first home when he moved to Johannesburg. The centre is a 3 story building that spans over a busy street.

The centres house training facilities, a jazz archive shops, gallery exhibition spaces, library and shops. The building further defines two urban squares which play host to the social interactions of the people around Alexandra.

The building learns from its surrounding context by creating a collage like façade of materials used in and around the immediate context. The juxtaposition of both tectonic and stereotomic infill sections creates a playful and light hearted presence in the context. The scale of the centre doesn't impose its self in the landscape but is able to mediate between its civic nature and the residential context. The building aims to give the people of Alexandra a place where

they can appreciate the past while embracing the opportunities of the future.

Principles learned:

- Materials and technology are learned from the context.
- The scale of the building is able to negotiate between its civic function and its residential setting.
- The public space is reclaimed and the street is a source of energy for these spaces.

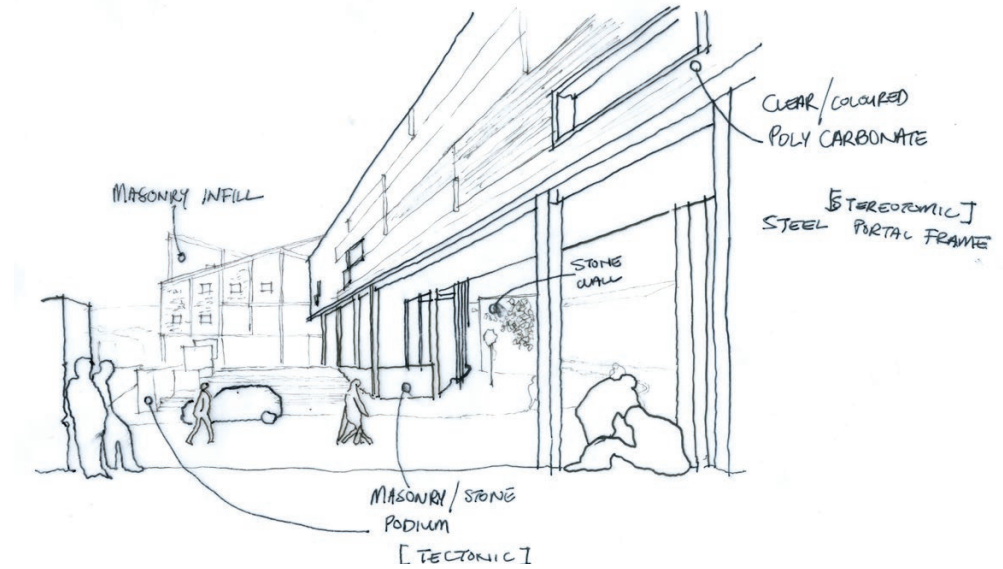

Figure 42: Material palette (Author 2016).

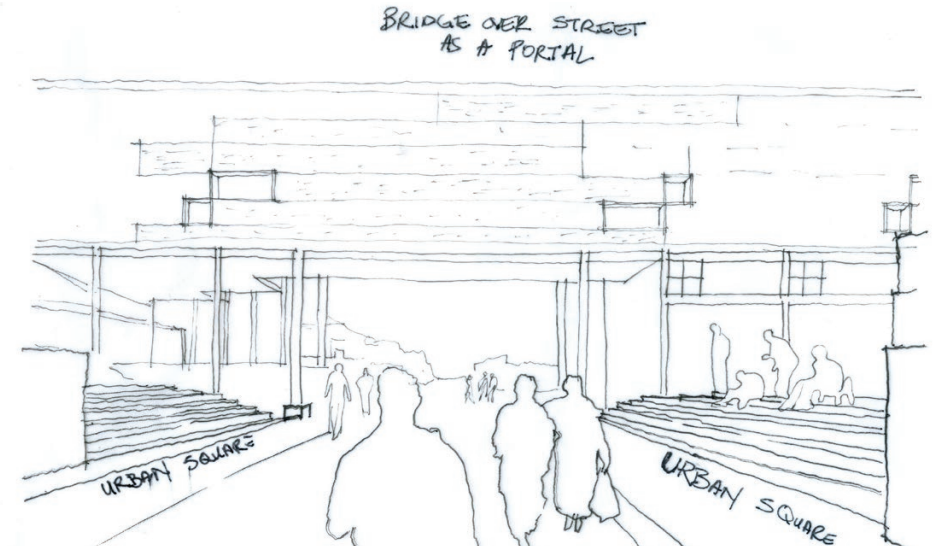

Figure 43: Definition of public space (Author 2016).



Figure 44: The building blends well with the context of Alexandra (Baan 2010).

5.2 OUTREACH FOUNDATION COMMUNITY CENTRE

Architect: Local Studio
Location: Hillbrow, Johannesburg
Project year: 2015

Precedent_ [Material, Technology]

The Outreach Foundation Community Centre is one of the first social infrastructure projects to be built in Hillbrow since the 1970. The building is situated on the roof top of a previously unfinished community centre. The three primary functions of the building are:

- Computer centre on the ground floor
- Dance studio on the first floor
- Office and meeting rooms on the second floor

The building uses materials that are rarely explored in the South African context. The form of the building is defined by its structure of light gauge steel clad with corrugated steel and poly carbonate sheeting. It gives homage to the industrial past of Johannesburg while still creating a new language within the built environment of the Hillbrow. The centre embodies the ideas of transparency, honesty, where materials are or dressed up or hidden but are exposed, displaying the intentions of the architecture.

Principles learned:

- Materials and technology are learned from the context.
- The architecture is able to negotiate with the aspiration of the community by honouring the past but also adding to the identity of Hillbrow. The current aesthetic of the city is not copied but is rather juxtaposed by the light steel structure against the concrete and masonry buildings.

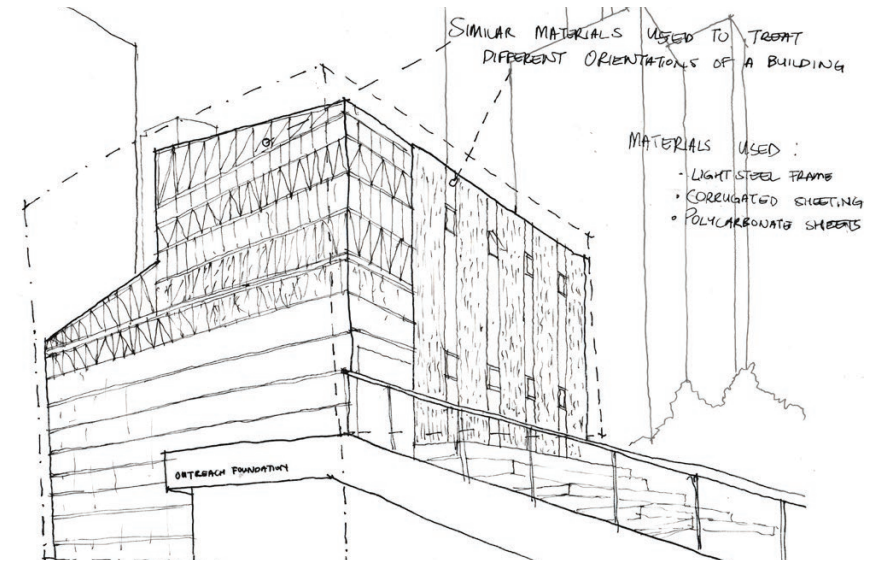

Figure 45: The skin of the building is different depending on the orientation of the wall and the function within the building (Author 2016).

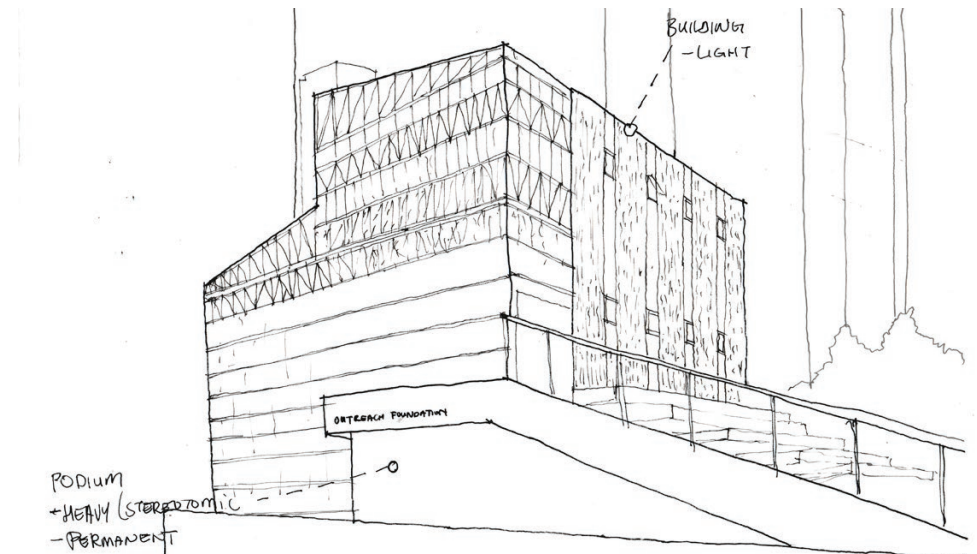

Figure 46: The Building is a light mass placed over the roof of an existing community hall. The community hall becomes the podium for the building (Author 2016).

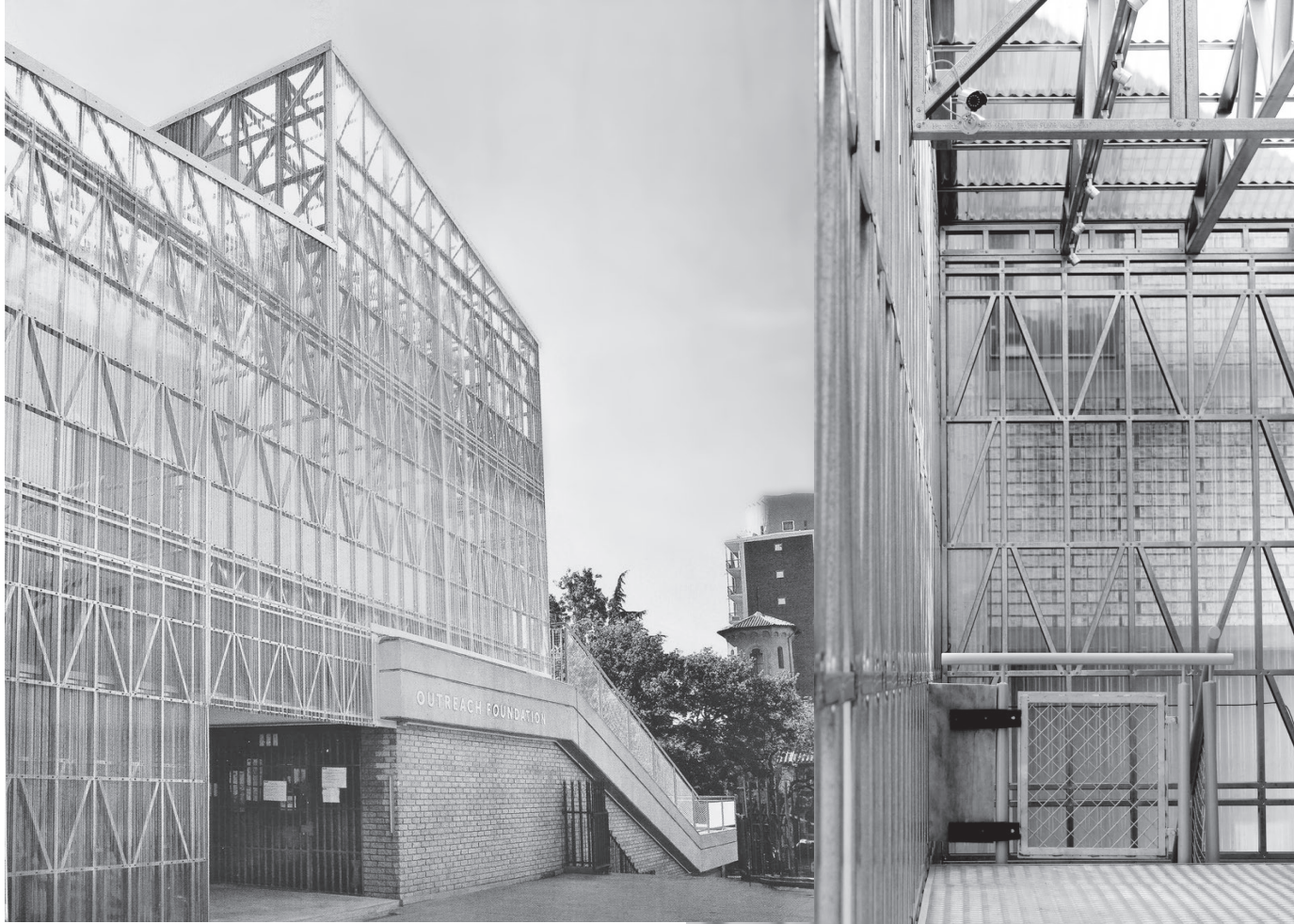

Figure 47:Material honesty as principle that embodies the characteristic of the material use of existing buildings in the immediate context (Local Studio 2015).

5.3 TAXI RANK NO.2

Architect: 26'10 South Architects
Location: Diepsloot, Johannesburg
Project year: 2012

Precedent_ [Design / materials]

Taxi Rank No.2 is located in Diepsloot, an apartheid township located on the outskirts of northern Johannesburg. It is a socially and economically volatile environment. The main taxi rank which connects it to the greater Johannesburg was in need of an upgrade and so, the project commenced. The project attempted to provide better public spaces within the township. The project aimed to improve the relationship between people and their public spaces but also provide a viable way of increasing the commercial viability of the rank and also the social standing of those that live and use the rank.

The rank's primary house

- The taxi rank.
- Administration offices
- Public ablutions
- Commercial spaces in the form of market stalls

“The rank upgrade is one of many planned within the city’s Corridors of Freedom, in line with the Johannesburg Growth and

Development Strategy 2040 (GDS).” (Johannesburg Development Agency [JDA] 2014). The strategy aims to ensure Joburg residents live nearer to their places of work and are able to work, live and play in them without having to use private motorised transport (JDA 2014).

The rank does not shy away from the street but converses with it by providing both a linear market which defines the street and an urban square where people can linger and congregate. “The intervention improves the environmental, social and commercial sustainability of the taxi rank and led to a layout which seeks to integrate the facility with the day-to-day life of Diepsloot” (JDA 2014).

Principles learned

- Celebrates the African street market as a public space
- Materials are derived from the material palette of the surrounding dwellings. Steel being the most predominant material used in shack construction.

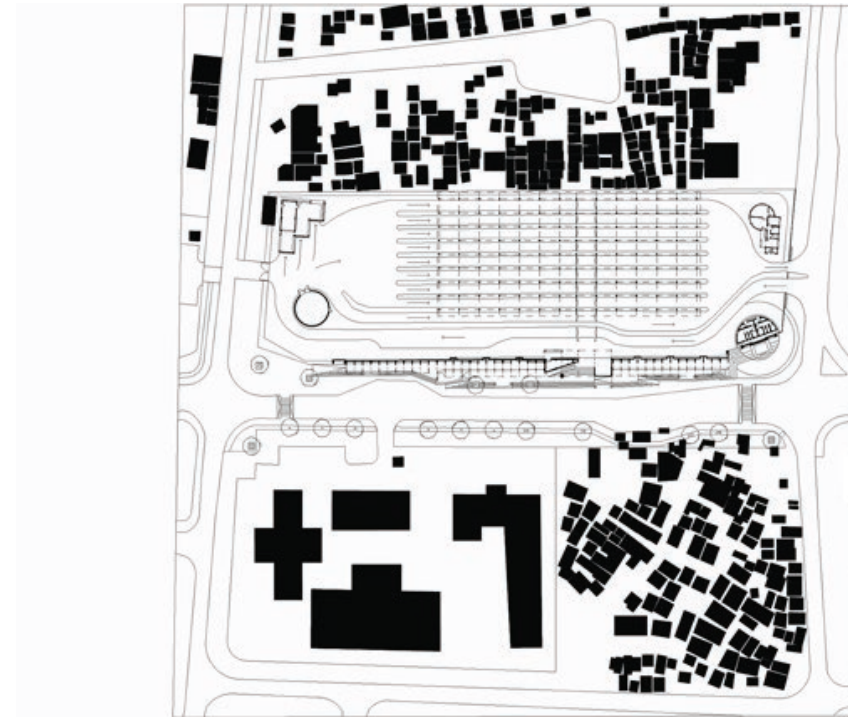

Site plan (2610 South Architects 2016).



Figure 48: The taxi rank within its context (Baan n.d.).

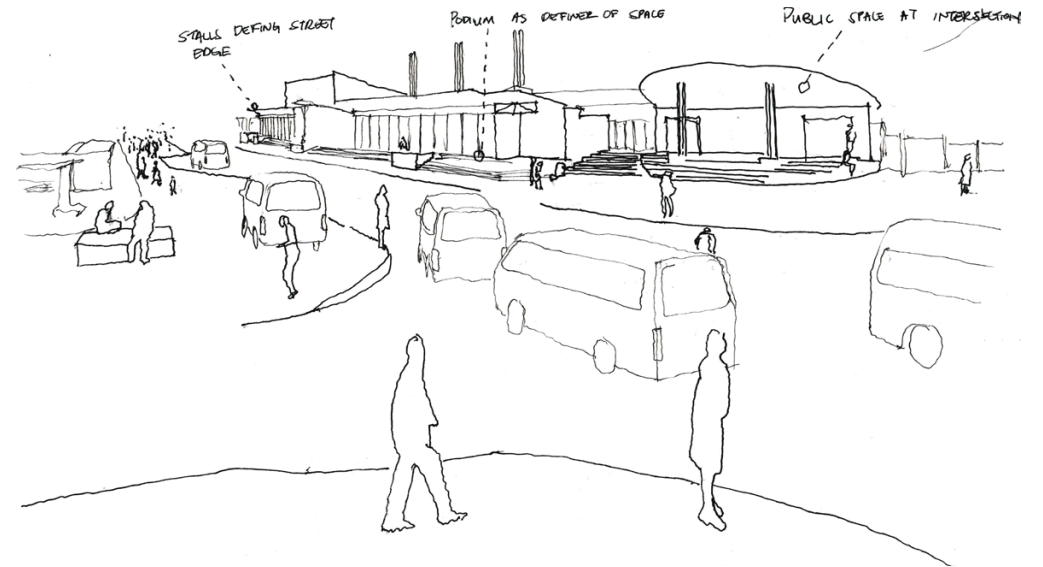

Figure 49: The linear market and public porch as the thresholds between the rank and the street (Author 2016).

5.4 VPUU – VIOLENCE PREVENTION THROUGH URBAN UPGRADING_ VPUU URBAN PARK AND ACTIVE BOX

Architect: Jonker & Barnes Architects / Tarna
Klitzner Landscape Architects

Location: Khayelitsha, Cape Town

Project year: 2011

Precedent_ [Urban]

The Violence Prevention through Urban Upgrading programmes aims to nurture sustainable and integrated communities. It does this by addressing issues and negative perceptions within the township. The programme integrates 5 components, namely:

- Community participation
- Social crime prevention
- Situational crime prevention
- Institutional crime prevention
- Knowledge management

The programme is invested in the active participation of the community, from the design inception phase all the way to the operation and management of the interventions. The first phase of the project proposed an urban park with a multi-purpose facility overlooking the park. This developed into the idea of 'balls on a string' (figure 32) concept where these multi-purpose

facilities, Active Boxes, are placed along a path that goes through the township. A previously dangerous route is redefined as a secure path for the residents starting from the train station, all the way through various neighbourhoods and undeveloped land parcels. These Active Boxes serve as landmarks within the context and serve as secure points for one to easily identify and go to in case and crime situation arises.

The Active boxes belong to community members, ensuring that these community facilities are maintained by them and also gives them the opportunity to be active in the safety of their neighbourhoods. The Active boxes are markers of safe public spaces. These public spaces are in the form of urban parks of varied scales depending on the location. These parks are not only recreational spaces but also safe spaces where people can congregate. What this programme has been able to

achieve is to change the perception of previously dangerous spaces into positive spaces that improve the lives of the people who use these spaces.

Principles learned

- The relationship the public space and the public building. The relationship allowed for both spaces to be used by the public and the energy(people) could occupy either the spaces or the building or even both.
- Decentralising security as way of reaching more people in a more economical manner

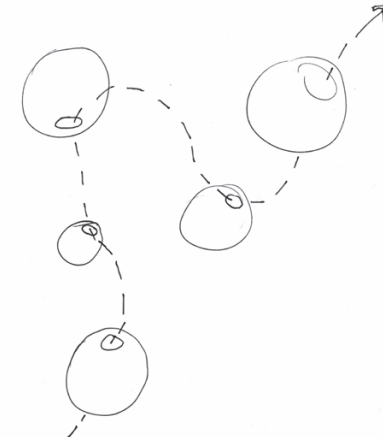

Figure 50: Active box along a route as balls on a string (Author 2016).



Figure 51: An Active box proximity to a recreational space (Dayton 2014).

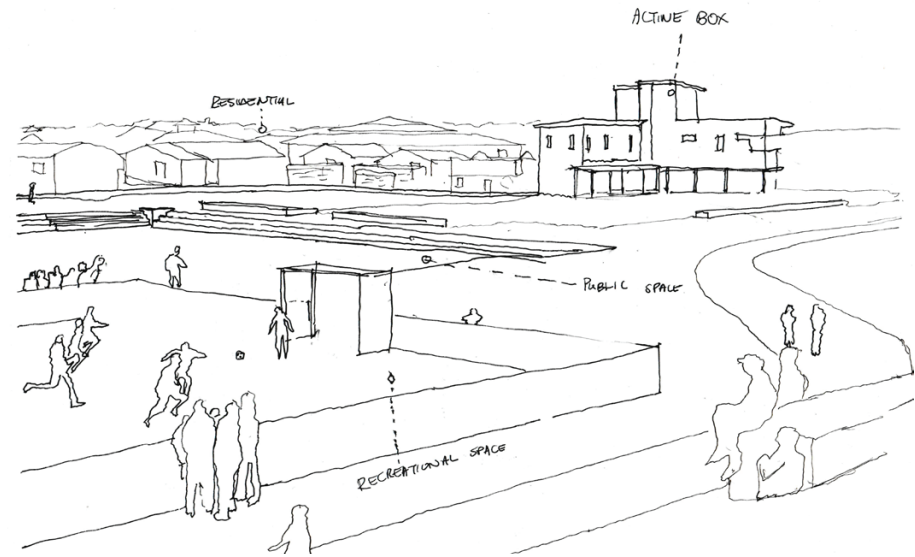

Figure 52: The Active Box is always placed close to a public space. It fosters a safe zone between the public space and residential zone (Author 2016).

5.5 KOBAN

Architect: Various

Location: Japan

Project year: Various

Precedent_ [Functional]

Koban or “police boxes” are scattered on the Japanese street scape. They are normally located near train stations, busy commercial streets and large public buildings. They act as community policing forums with the objective of deterring street crime.

They act as miniature police station where a member of the public may find one to ten police officers at a time who patrol their neighbourhood. The Koban are used by the public to seek directions, report petty crimes and as secure locations for people who are in need of security.

Principles learned

- Decentralised public service provision as way of reaching more people but also to provide a different perception to an otherwise highly institutionalised government entity. This allows for members of the public to be served in an efficient and manner.



Figure 53: Typical Koban (Thomas 2016).



Figure 54: Contemporary Koban within the city (Klein Dytham Architecture 2012).

6

THEORETICAL APPROACH

The theory component to this dissertation is focused on defining what public architecture is and can be. This will be in an urban scale and a local scale. Together with this, the aspirations that one can achieve through public architecture will be discussed as well as the idea of a shared identity through public architecture.

6.1 URBAN PUBLIC SPACE_ OUR “AFRICANESS” AND OUR SPATIAL LEGACY

With the coming of democracy in 1994, South Africa changed from being a European colonial outpost to being an African country ruled by black Africans (Steyn 2008: 42). The new leaders have their own set of ideals, goals and aspirations which differed from previous leaders. With this new change, one would try and disregard the past in search of a future but one must consider the colonial history of South Africa and the fact that it should not be erased but recognised as a reality. This poses a question of what “Africaness” is in the context of South Africa with its colonial history. A deep understanding of context needs to occur. The design of the urban spaces should respond to the demographic legacies present in South Africa. This could give architecture the potential to mediate these factors and have the ability to reflect the idea of “Africaness”.

The apartheid spatial legacy left a scar in

the South African landscape. This should not be ignored as it would be the same as ignoring the events that brought South Africa as well as negate the consequences of these events. The question then is, how does architecture address the spatial scarring left by South Africa’s past in a manner that not only acknowledges it but also attempts to re-imagine the urban space beyond its current condition. Steyn (2008) speaks of a good architecture being able to firstly address the African identity and its intertwined legacy heritage together with South Africa’s European and Asian heritage and secondly an architecture that responds to the physical, natural, social-political and historical context. This poses a difficulty for large scale civic buildings as they have to address a larger audience as opposed to a dwelling or a house.

Steyn (2008) suggests that that characteristics that could render the environment

African, are firstly the way our streets are occupied by hawkers and traders and secondly, the way informal settlements are shaped and inhabited. These are principles one could use to derive an appropriate architecture, an architecture that replaces the notion of a building as an isolated object in space and rather as a building that encourages connectivity of people to the built environment and social spaces to encourage better relationships among people.

The understanding of what an African urban space may be is very much dependant on the context in which one works in. Architecture should respond to the conditions it is presented with, whether they are physical, social, political or economic and this will change radically from site to site. In the case of this dissertation, the context deals with a community with a majority disadvantaged black people.

6.2 PUBLIC SPACE_ THE GOOD NEIGHBOURHOOD

European cities such as Barcelona and Paris have better designed public spaces, spaces that are not as celebrated in the South African context. South African cities have not had the same opportunity to have public spaces that can evoke feelings of pride and ownership. If one looks at the way in which RDP (Reconstruction and Development Programme) housing has been supplied in South African townships, the focus was on merely providing housing to meet the goals set out by the RDP and later the GEAR (Growth, Employment and Redistribution) strategy (Wehner 2000). This has created communities whose need for housing are being satisfied but in manner that deprives them of a quality life. These settlements are placed even further away from places of employment and economic opportunities and are created without providing the basic amenities needed by a community. This re-occurring practise perpetuates the spatial inequality experienced by many in the

Apartheid era. That is not to say that there are not any spaces afforded to the public, they just so happen to be organic in inception and growth. The African market is such a space and is discussed below.

6.2.1 The African space

There are major differences between the European and African perspectives of space. Lloyd (2003) highlights the European perception of space being private except for spaces that are specifically labelled as being public or for public use. Africans on the other hand perceive all space as being public except for spaces reserved for rituals or events which are designated as being private (Lloyd 2003: 107). This distinction shows clearly the different mind sets one may have when it comes to space depending on one's heritage. With this lens, the African market space and the street have the potential to become important components to the formation of new public spaces.



Figure 55: African public and private space [Diptych of a street market in Soweto on the left and a menstruation hut in Sangha on the right] (Adapted by Author 2016).



Figure 56: European private and public spaces. [Piazza della Signoria on the left and a Suburb in Colorado Springs on the right] (Adapted by Author 2016).

“The African market space is a terribly contested space, with vendors occupying a major portion of the side walk, often forcing customers and passers-by to share the street with taxis” (Steyn 2008: 159). An informal settlement can be characterised by the ever bustling street edge which affords the traders economic sustenance and the community with a lively and ever changing public realm. A large number of residents in Mamelodi still rely on walking as a mode of transport. This solidifies the importance of the street as a public realm but also the nature of most African public spaces being linear. The adaptation of the linear public realm is an important design driver for this study and will be the first element implemented and of which the design project will continue from.

6.2.2 The public architecture

Graham (2006) questions whether there can be public architecture. If architecture can be considered public, then it has to satisfy certain conditions. Graham (2006: 247-248) suggests that the architecture must both serve and give spatial expressions to the functions that members of society can appropriate. That means the architecture; the spaces around buildings and the function of said architecture, should not exclude any member of society. Therefore architecture will not merely become public because it was made for the public but that its functions can be appropriated by its users without exclusion.



Figure 57: Street edge activity [Hector Peterson road in Lusaka, Mamelodi] (Author 2016).

Aspirations in South Africa drive the individual in how and what they do. Success becomes an aspiration and, more importantly, the symbol of success which people aspire for. These architectural symbols of prosperity in the form of house styles can be seen in most suburbs located in East of Pretoria. This is why the built environment is scattered with Tuscan styled houses (Steyn 2008). This is the architecture that people in informal settlements and RDP settlements aspire towards. It is a style that is synonymous with economic growth and prosperity. This is not only true to the lower income home owners, but also to the middle and higher income homeowners. It begs the question whether one should really judge the taste that many agreed upon.

6.3.1 The vernacular

If one is to be inspired by the vernacular, one needs to understand what the vernacular is in a post-Apartheid society. As Steyn (2008) states that vernacular is not a style but a tool, a tool where design principles similar to those associated with critical regionalism can be learned and used to design appropriate architecture. That means there is value in the shack dwellings, in their materials and in their urban form and layout.



Figure 58: Informal settlement patterns and dwellings as lessons in rationalistic design [Alaska, Mamelodi] (Author 2016).

One has to be careful in such a context to not patronise a disadvantaged community by imitating their architecture as a means of creating an environment that they will find familiar and can associate with. Projects that aim to imitate the use of local materials, construction methods and technologies tend to be viewed as backwards and negatively received by a community as they see it as a ploy by the architect to mock their poverty (Steyn 2008: 50-51).

Therefore, the designer in this sense has the responsibility of synthesising the aspirations of a collective and the characteristics that make a built environment unique and function well. An appropriate building in this context will therefore engage with its physical context, its climate, its accessibility and its public space (Steyn 2008: 53) rather than being solely determined historicism.

This dissertation is about celebrating the public realm by appropriating spaces for daily rituals that form part of their life. It is suggested that an appropriated civic function should be applied to a community's needs. The civic service should then be placed in the public realm so as to foster a relationship between the architecture, the community and the public realm. The architecture then becomes the background upon which the relationship is played out and therefore the architecture takes the backseat and the rituals of the 'everyday' (figure 59-61) in the 'everyday space' becomes paramount. The architecture should be a manifestation of contextual characteristics, economic realities, existential necessities, aspirations and choice. This is a search for an appropriate architecture and for social equity.



Figure 59: An existing church found on site. Religion forms a part of the daily rituals on the site (Author 2016).



Figure 60: Soccer match on Victory soccer field [Lusaka, Mamelodi] (Author 2016).



Figure 61:Market spaces where people socialise an earn a living [Lusaka, Mamelodi] (Author 2016).

7

DESIGN DEVELOPMENT

7.1 THE CONCEPT

7.1.1 The programme

The programme of the design project was developed around the idea of decentralising the functions of the health and policing services in Mamelodi. The decentralising of these amenities is done with the aim of bringing basic services directly and more efficiently to the public. The public amenities administrative functions will be decentralised, allowing for blue collar activities to be delegated to the local community thus allowing them to participate in the well-being of their community.

On the health services, the COPC (Community Orientated Primary Care) will be the organisation that will be accommodated in the design project. The CPF (Community Policing Forum) will fall under policing services. These two organisations allow for members of the community to participate in the well-being and safe guarding of the community. These organisations are supported by the local clinics and police stations allowing

for a far more streamlined provision of services to the public with the backing of larger institutions, that is, existing hospitals and police stations in townships.

The COPC and CPF will be supported by bringing the municipality as a stakeholder in the project. The public amenities map, figure 10, shows there are only two Thusong Service Centres in Mamelodi. It is proposed that a Thusong Service Centre forms part of the programme of the design project to create a centre where the basic services the public may need are located in a central location.

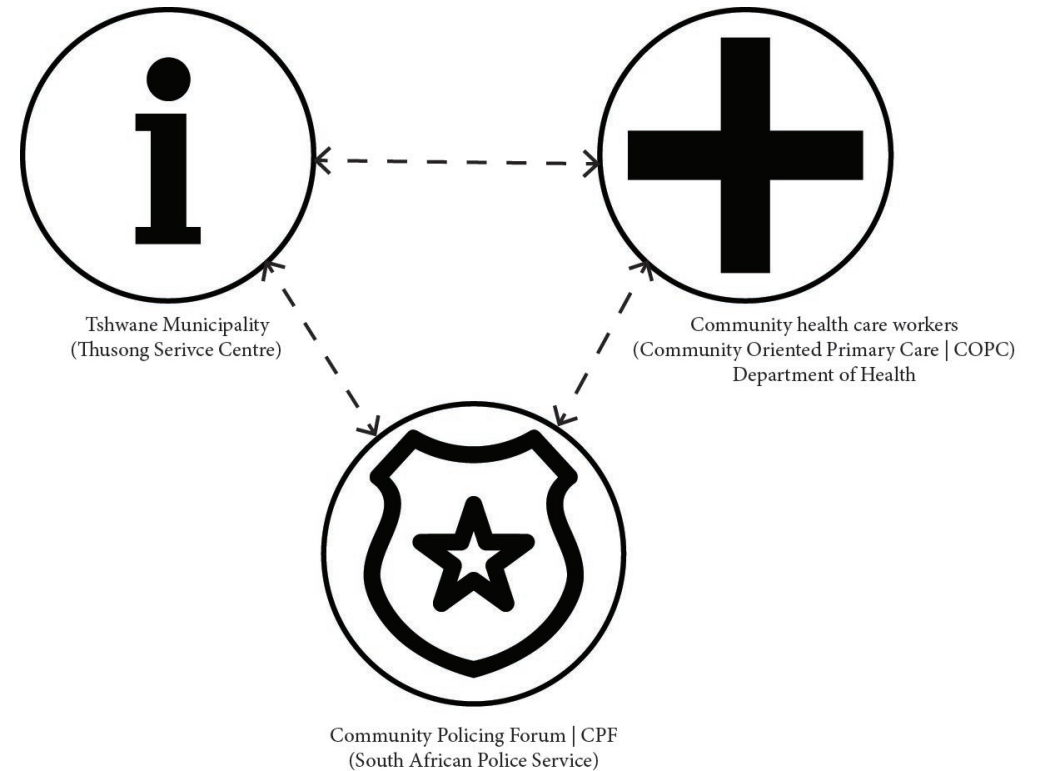

Figure 62: Stakeholders of the design project (Author 2016).

7.1.2 Phase 1

It is proposed that the project is situated in two levels of engagement, one being at a residential scale and one being on a civic scale. The first concept to be discussed is the proposal on a residential scale. Lusaka is highly populated and the informal settlements surrounding it add to the density of the area. It makes it hard for policing and medical services to reach households due to the inability to direct these services to an address or exact location. To better deal with this issue, the COPC has a geo-location database on which they record the households they are in contact with. This database will have the members of the household, the location of the household, the health status of the members and other information pertaining to their medical status. This database will be adapted and used to work together with the CPF and the larger police services in the second phase of the project.

Small hubs are proposed to be provided in neighbourhood. These hubs create a network which connects to the civic intervention in Concept B of the project. A single hub will serve a 10 – 20 households and will serve as a connector of these households to clinics, hospitals and police stations through the hubs and the civic intervention (see figure 63). The hub will be geo-located and serve as a point through which medical and policing services can be provided in case of an emergency. These services can then be provided to the specific household.



Figure 63: Network of Hubs which connect to phase 2, the proposed civic intervention (Author 2016).

CONCEPT A - PRECEDENT

The creation of each small hub will be based on the upgrading of an existing node. This node may be an existing shop or spaza (Tuck shop) with a big presence in the neighbourhood, a public transport node or a community leader as. The other criteria this hub has to satisfy the ability for vehicular and pedestrian access.

The incremental growth of economical nodes such as shops in the township occurs organically. The precedent below is of a local spaza shop, which over the years grew

to have a rental space which is a salon currently and a car wash on its street edge. This growth is due to the exposure of the spaza to the busy street, Hinterland Ave., the node was able to grow from a street side spaza shop in 2008 to an activity node in 2016 as illustrated in figure 64.

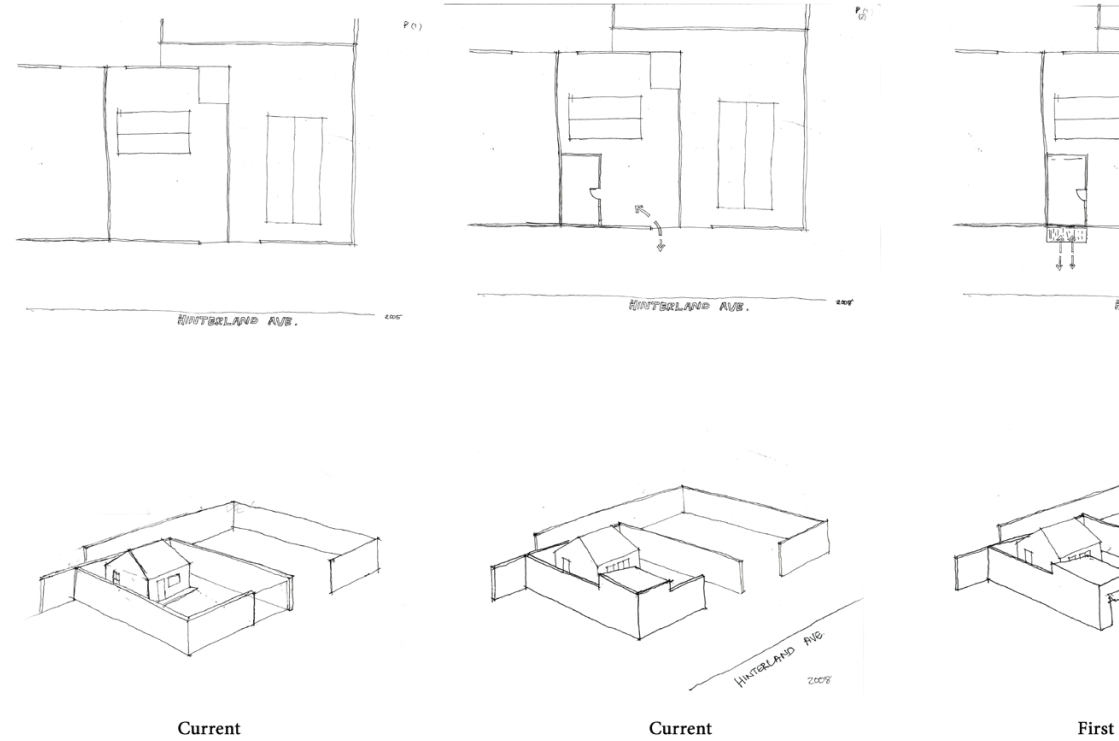

Criteria for nodal development:
Existing node: Commercial
"PT" zone
Community leader
Access: Pedestrian
Vehicular

Figure 64: The growth of street side spaza in Mamelodi Gardens, Mamelodi East (Author 2016).

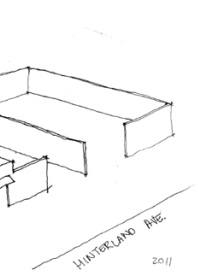
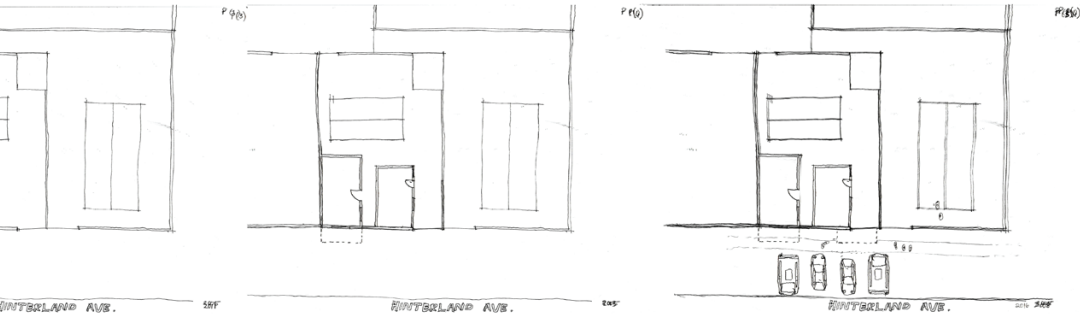

Phase

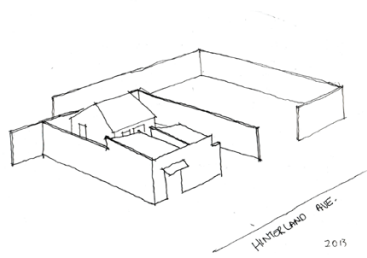

Second Phase

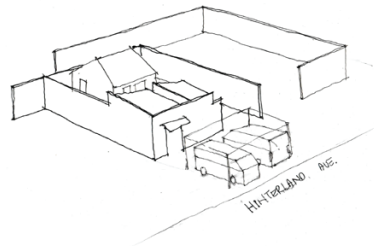

Third Phase

CONCEPT A - PROPOSED GROWTH

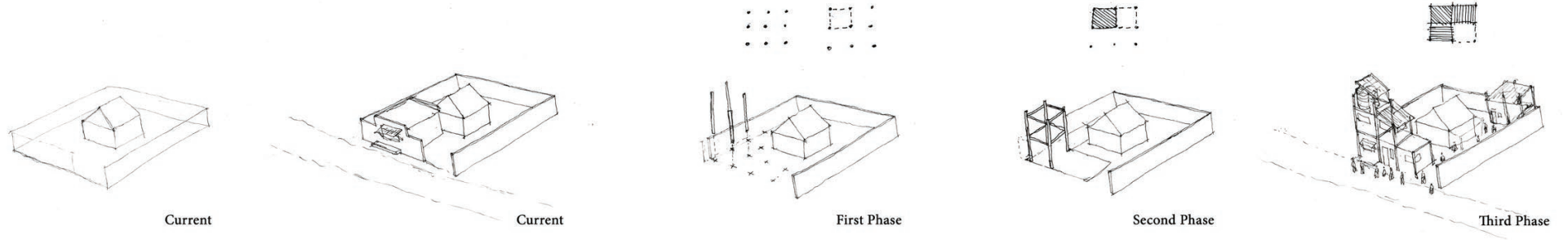

Figure 65: Potential growth of a typical hub (Author 2016).

The hubs will be upgradable buildings which can grow if there is a need for larger spaces. They will work on the same principles as small spazas and similar business and how they grow of the years as they get more and more exposure as shown in figure 65. The growth of the hub will be incremental and it will share its ideas of modularity and adaptability with those of the civic intervention.

7.1.3 Phase 2

The second concept of the design project is a civic scale proposal. Lusaka, as previously mentioned, has elements of temporality and permanence. This is evident in the type of housing within the context as seen in figure 48. This creates an interesting duality that will be manifested in the design project. The approach is that of providing enough structure to become a catalyst of change but to also give enough freedom to allow for adaptability as the community moves along the axis between temporality and permanence. A guiding

principle in achieving this is to make the public space the most important element within this design. The identification and defining of the public space becomes paramount. In this respect, the building becomes background for the public space, the foreground. The architecture becomes less about the building as isolated entity but as interaction between the buildings and the landscape.



Figure 66: Shacks and RDP buildings in Lusaka (Author 2016).

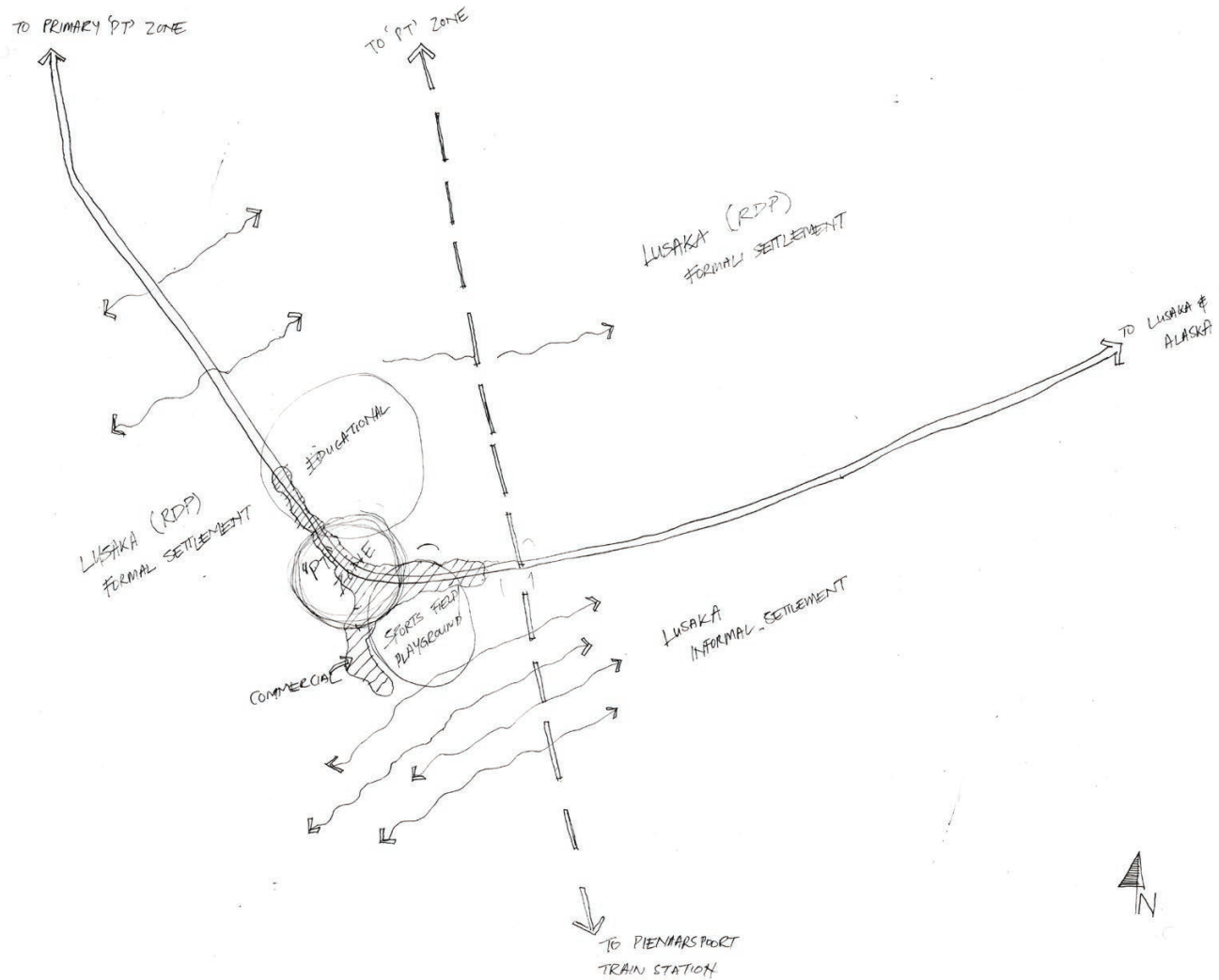
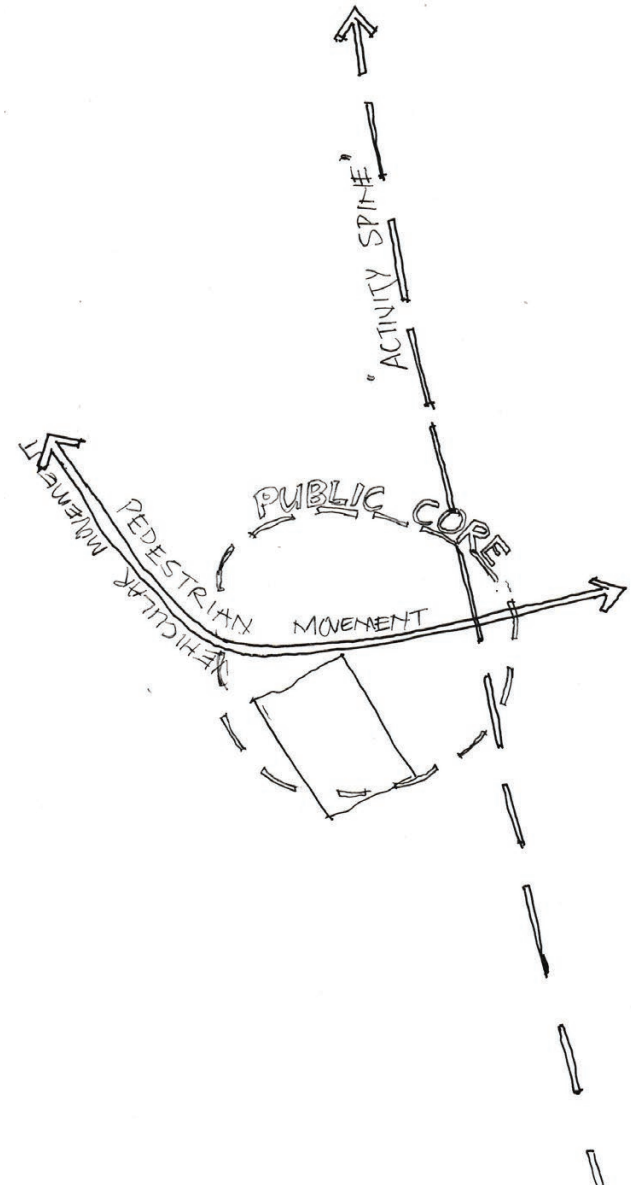

Figure 67: Urban plan sketch derived from understanding the context and incorporating in the urban vision (Author 2016).



Urban intentions. (Author 2016).

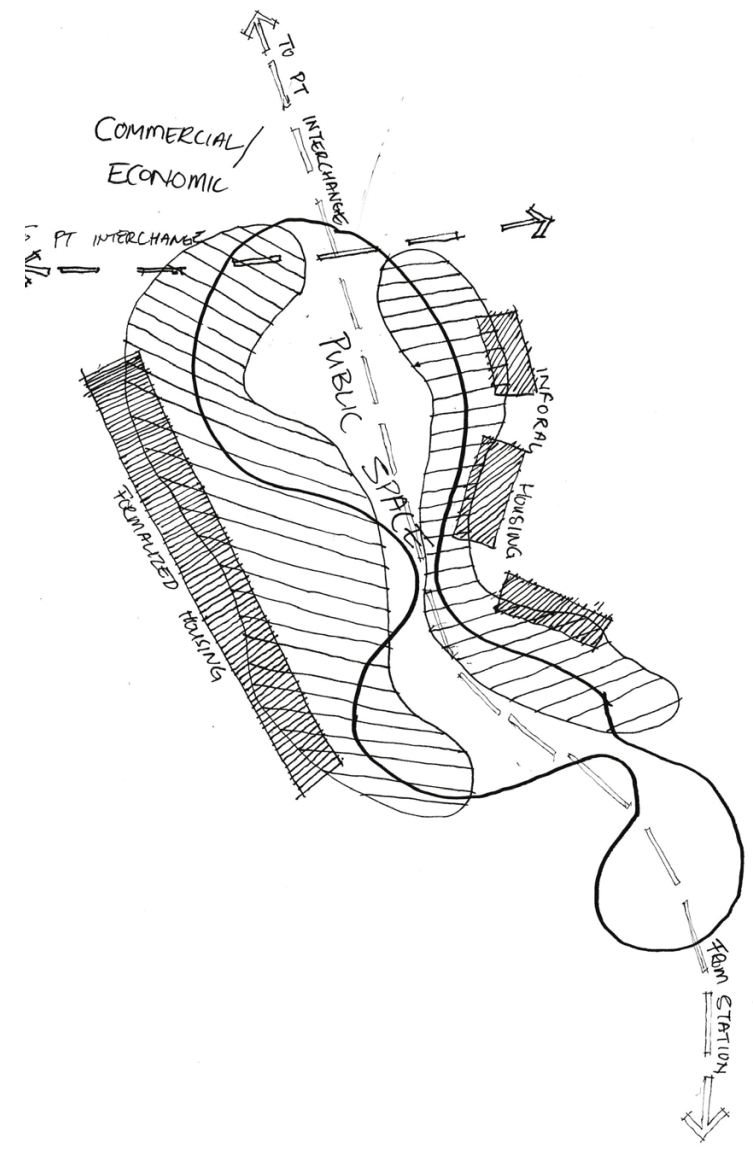
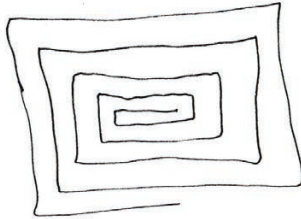

Figure 68: The public space becomes the most important space and the intervention is based on these spaces. (Author 2016).

PUBLIC SPACE AS A SQUARE



PUBLIC SPACE AS A LINEAR FUNCTION

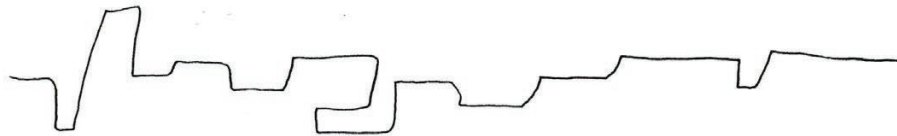

Figure 69: The public spaces will have qualities from a square typology to a linear typology (Author 2016).

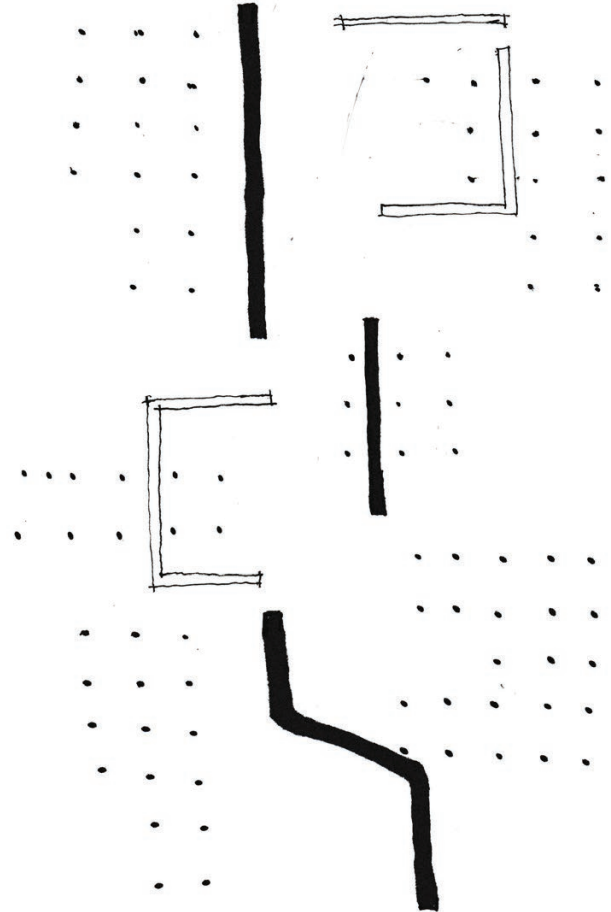

Figure 70: Partii Diagram. The public spaces will be control by grid and small structures to loosely define space (Author 2016).



Figure 71: Concept model



Figure 72: Concept model

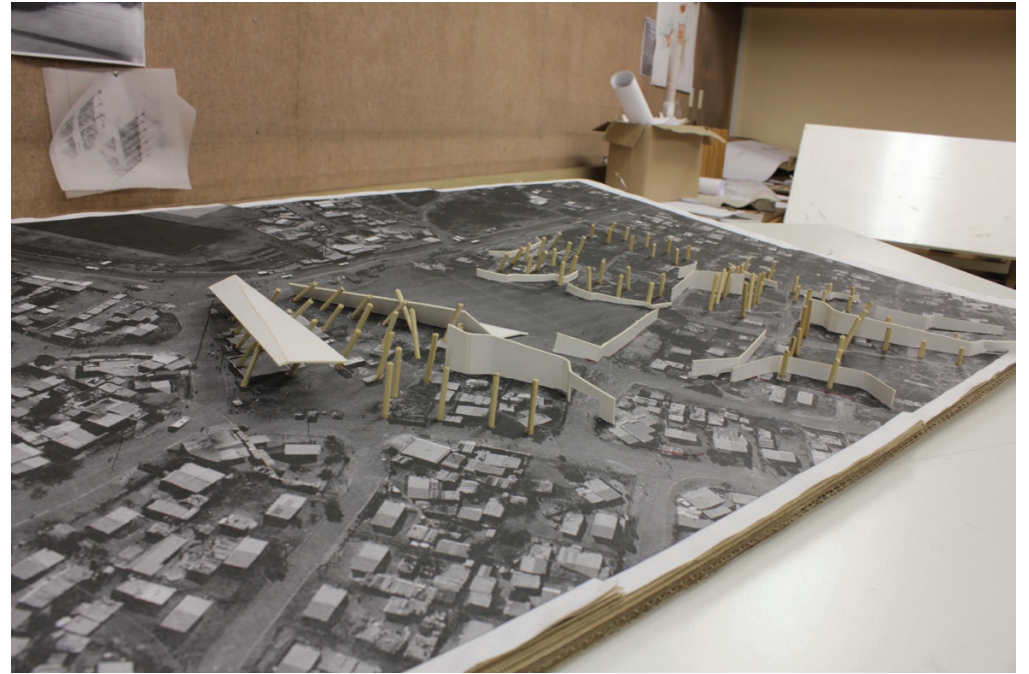

Figure 73: Concept model

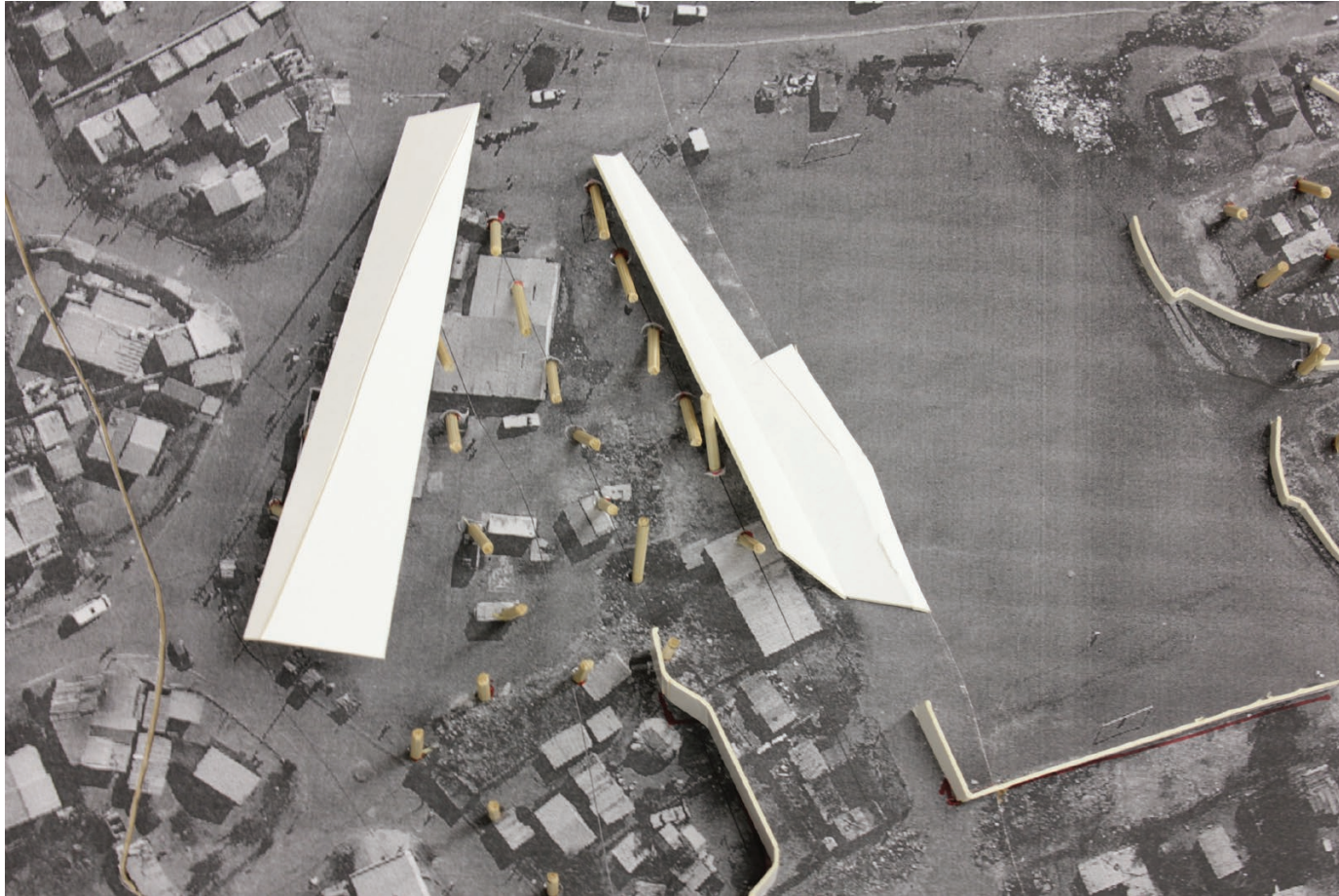

Figure 74: Concept model

7.2 PRINCIPLES

To begin with the design process, the principles discussed below, had to be established to aid in achieving the intention of creating an appropriate architecture for the community of Lusaka. The principles are revealed in both text and diagrammatically.



Context that is in flux

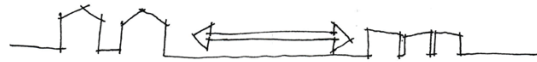

Public space as common space

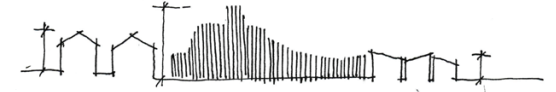

Civic to residential scale



Edge treatment and boundaries:
Boundary as demarcation
Boundary as defense mechanism

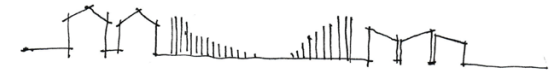

New centre as new public space

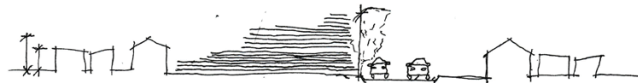

Relation to the road:
Scale

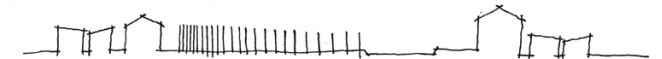

Transition from public to private space

Figure 75: Design principles employed in developing the intervention (Author 2016).

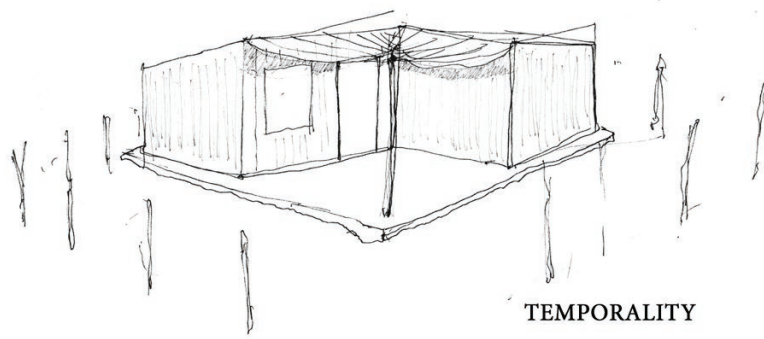

TEMPORALITY

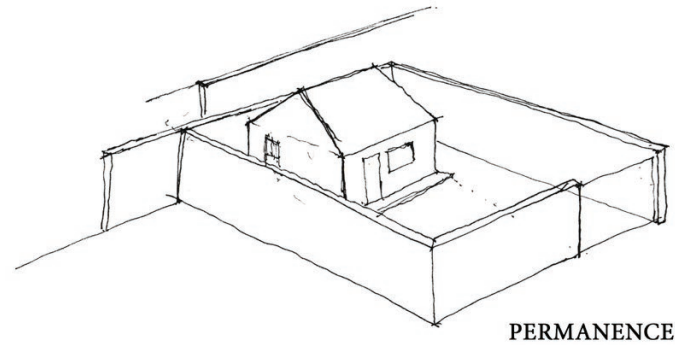

PERMANENCE

- The duality of temporality and permanence is explored and used to derive principles to design with.

Figure 76: Temporality and permanence (Author 2016).

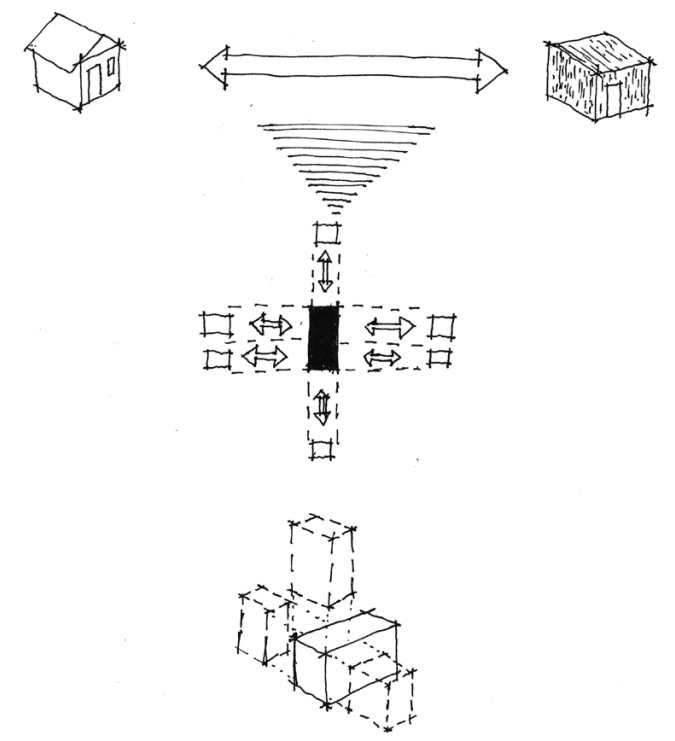

Figure 77: Synthesis of the qualities of both temporality and permanence (Author 2016).

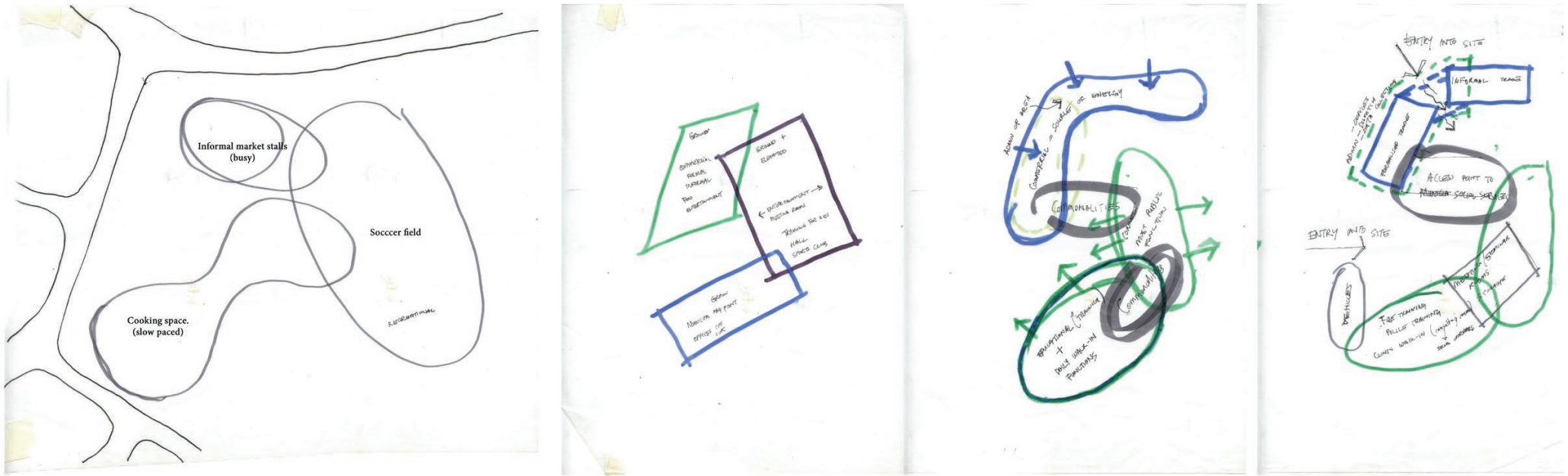

Figure 78: identifying public and structuring the internal programmes according to the public spaces (Author 2016).

To begin the process of organising the spatial layout of the project started by:

- Identify activities on site (figure 78):
 - Economic activity – reflect on site (Market space)
 - Recreational space
 - Communal space
- Identify possible functions on site (figure 78):
 - Market space
 - Recreational space
 - Communal space



Figure 79: Definition of public spaces A. Existing activities and spaces on the site are defined and the arrows show the relation to the street. B. The edges of the proposed building are shown. C, the various components of the building and their relations to the street and the public spaces around them are illustrated.

- **Defining the street edge**

Understanding the context, the street edge on Hector Peterson Road, is an important space as it is the most occupied and active space. Most activities associated with the street edge are those of a commercial nature such as stalls, carpenters, welders, cabinet makers and mechanics. The street edge is a source of energy that will be funnelled into the identified public spaces to bring life into these spaces.



Figure 80:Massing model that defines the 3 public spaces on its edges (Author 2016).

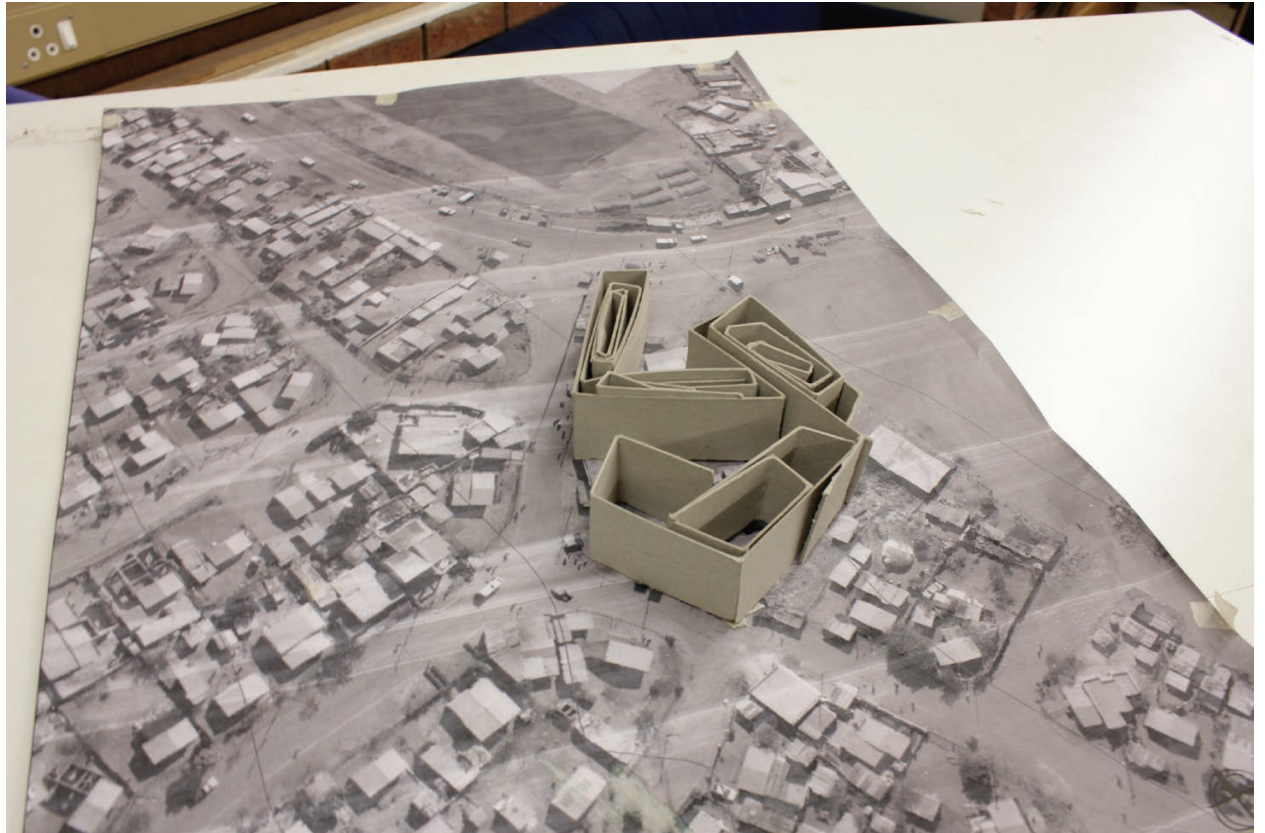

Figure 81:Massing model that defines the 3 public spaces on its edges (Author 2016).

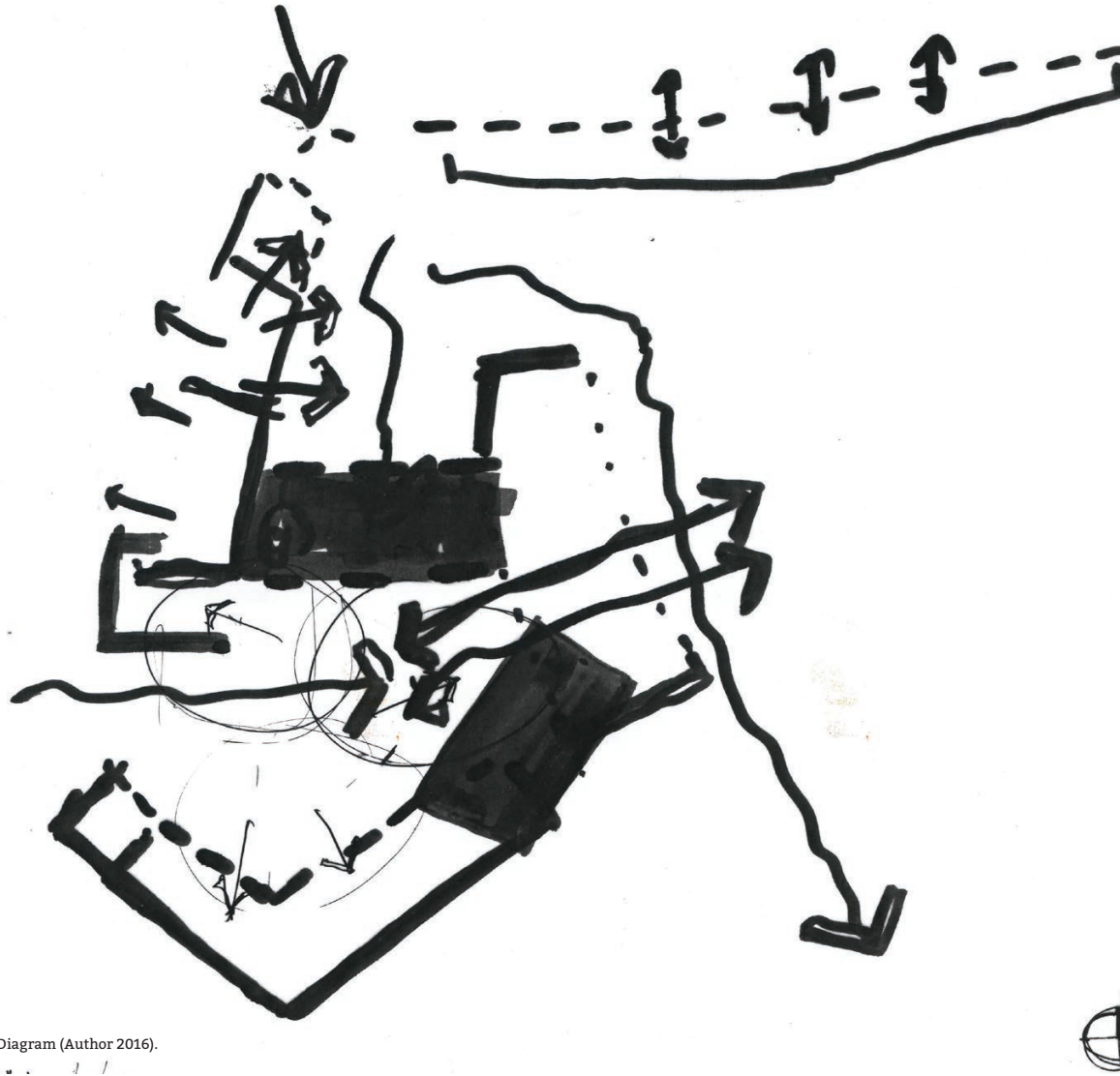

Figure 82:Parti Diagram (Author 2016).

Phase 1 of the project will not be investigated but it forms part of the narrative as well as the programmatic function and feasibility of the concept B, the civic building.

7.3 INITIAL DESIGN

The following images show the initial process of relating the programmatic functions to the public space proposed. It is important to define the street edges and the public space and the public spaces had to be connected, so fluid pedestrian movement from the street towards the internal spaces of the site is important becomes a principle that is carried throughout the building.

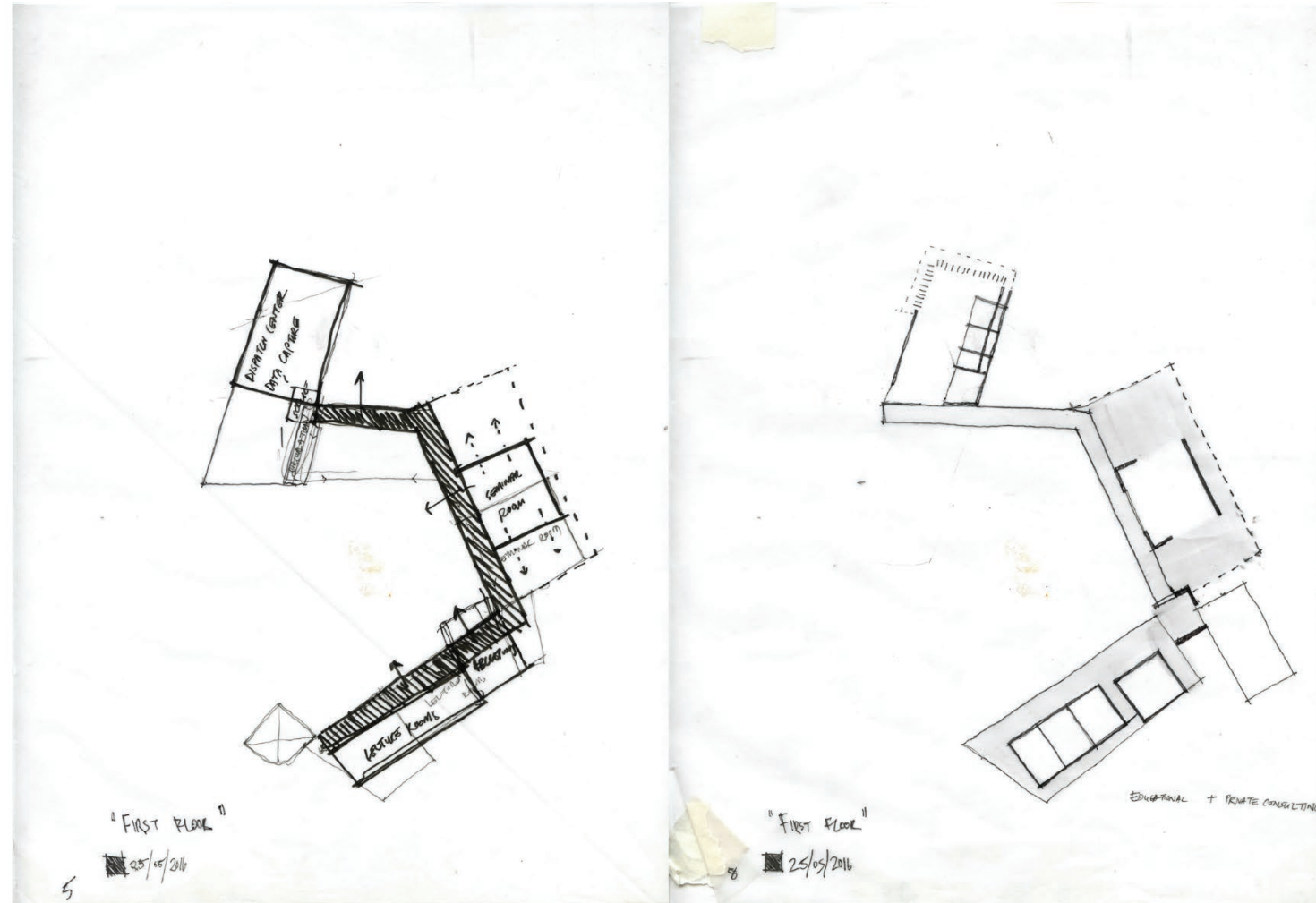
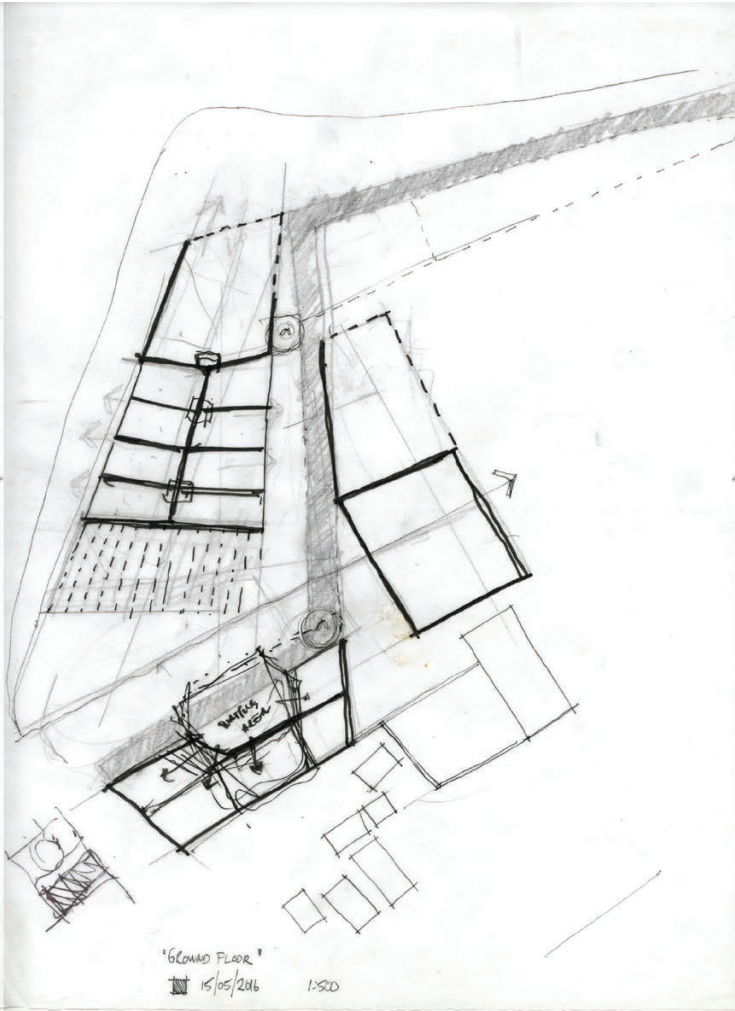
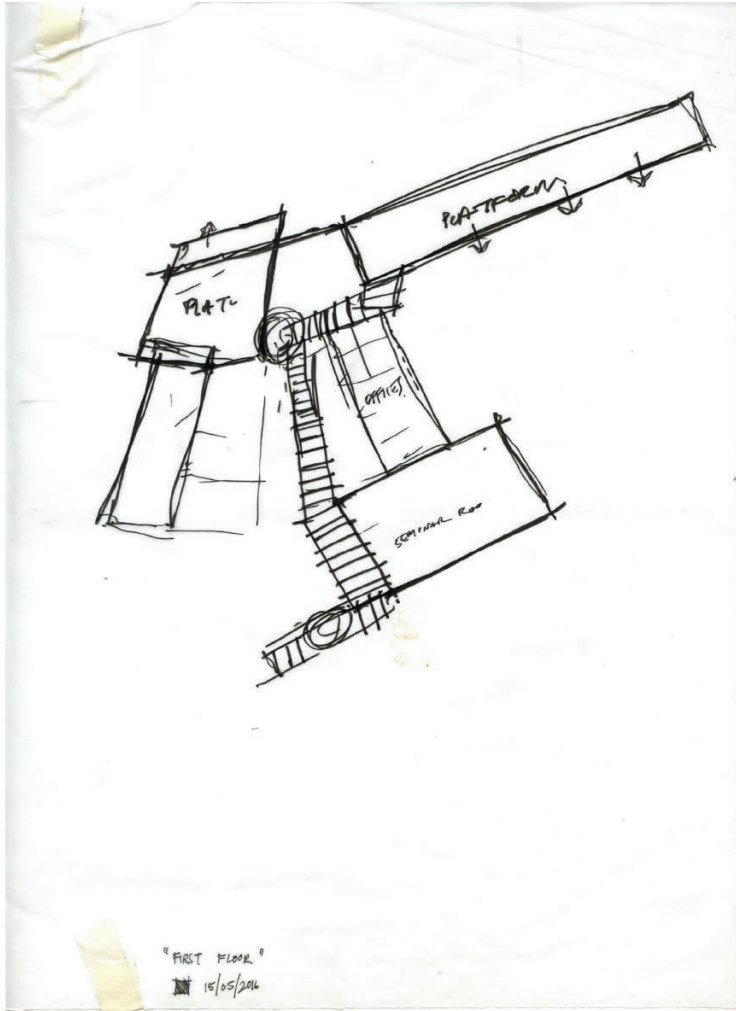

Figure 83: Site Plan development. (Author 2016). The proposed public spaces are related to the programmes in the building.



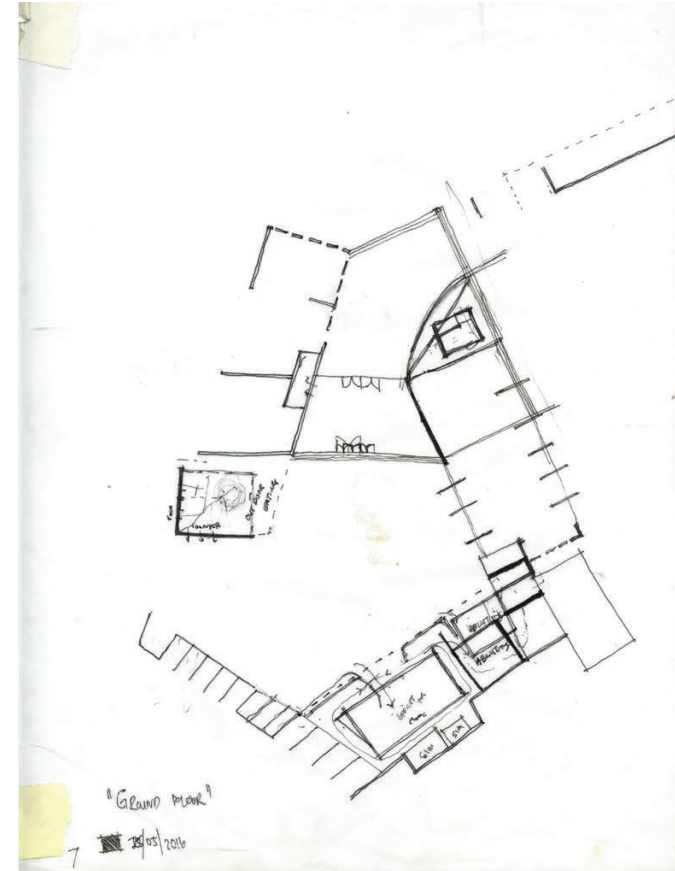
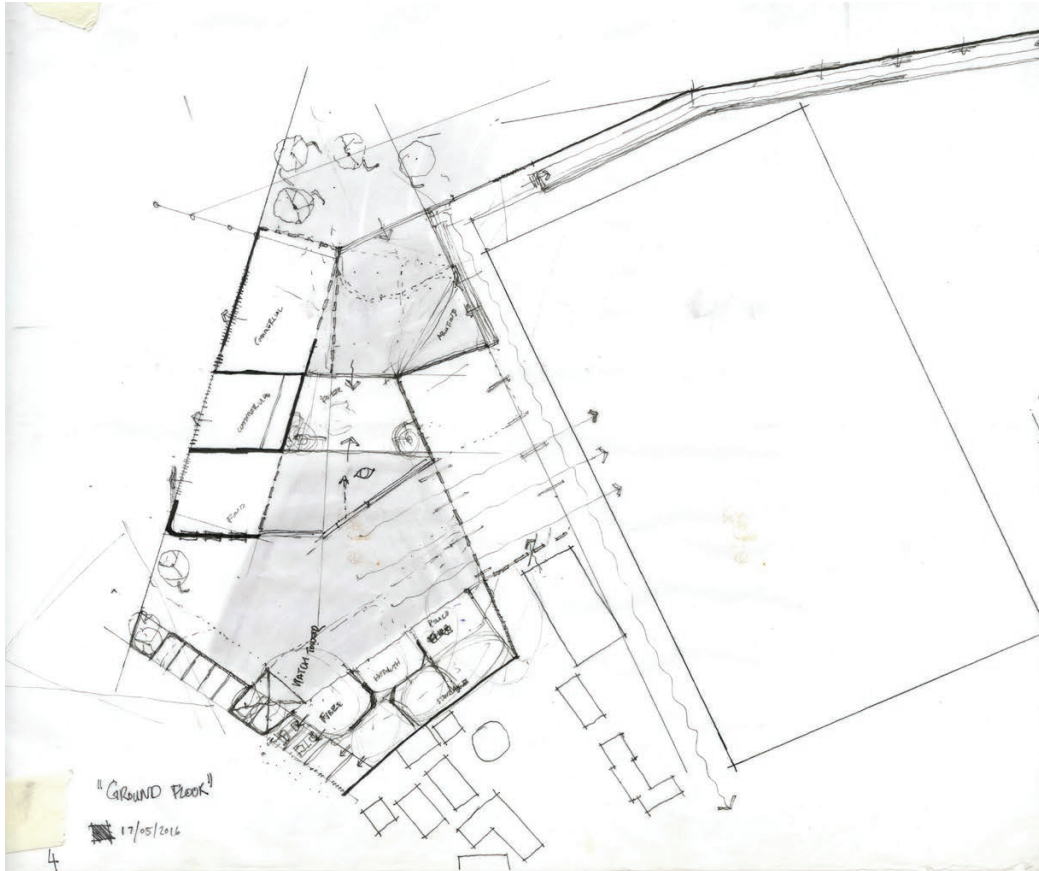

Figure 84: Site Plan Development (Author 2016). The existing pedestrian movement across the site is maintained and visual links between the street and the public spaces are created so that the spaces are not closed off from each other.

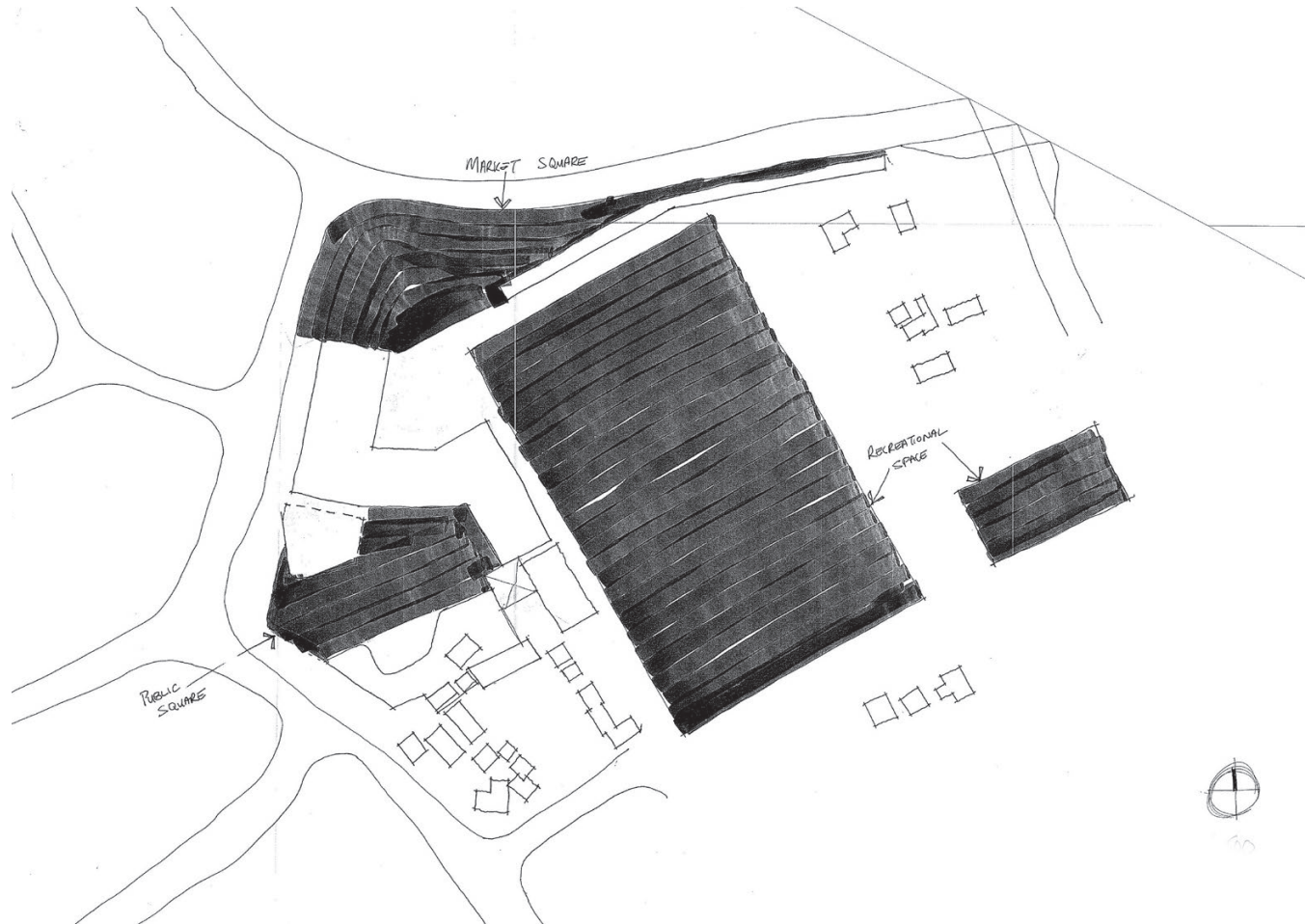

Figure 85: illustration of the public spaces (Black) and the structures that define the spaces (Author 2016).

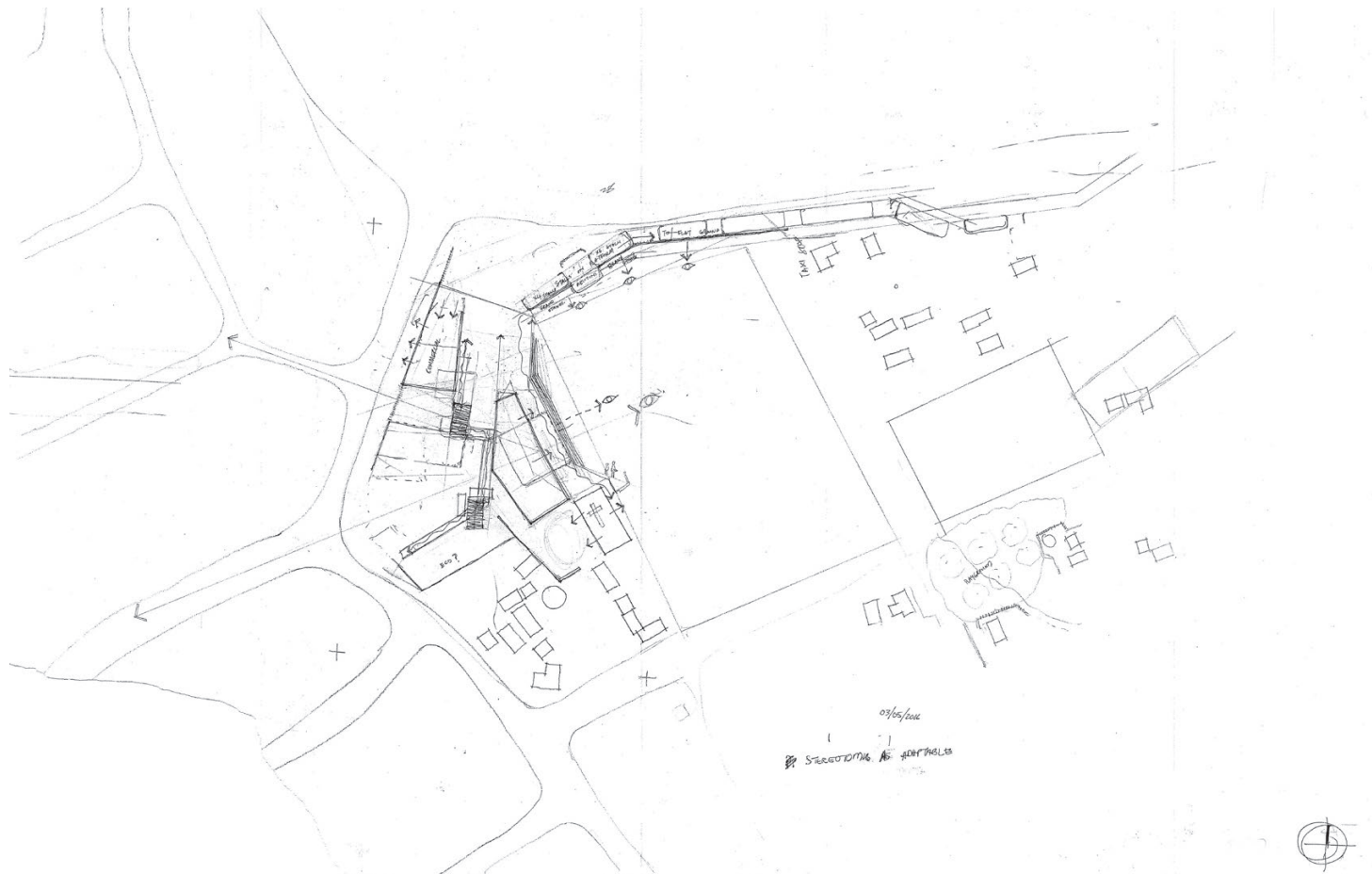

Figure 86: Draft site plan illustrating the response to the street edge, public spaces and existing view across the site. N.T.S(Not to scale) (Author 2016).

By understanding the form of the public spaces on a plan allowed for the buildings around the spaces to be extruded and then see how the buildings define the public spaces on 3D. The massing model, figure 85 & 86, show potentially how the

building will relate to the public space on a civic and residential scale. The mass model exercise achieved the definition of the public space on a three dimensional level. The market and recreational spaces are celebrated on a civic scale with double

volume masses while the communal space is defined by single storey volumes. This will aid in creating a human scale that is intended for this space as well as facilitate a relationship with the surrounding residential units.

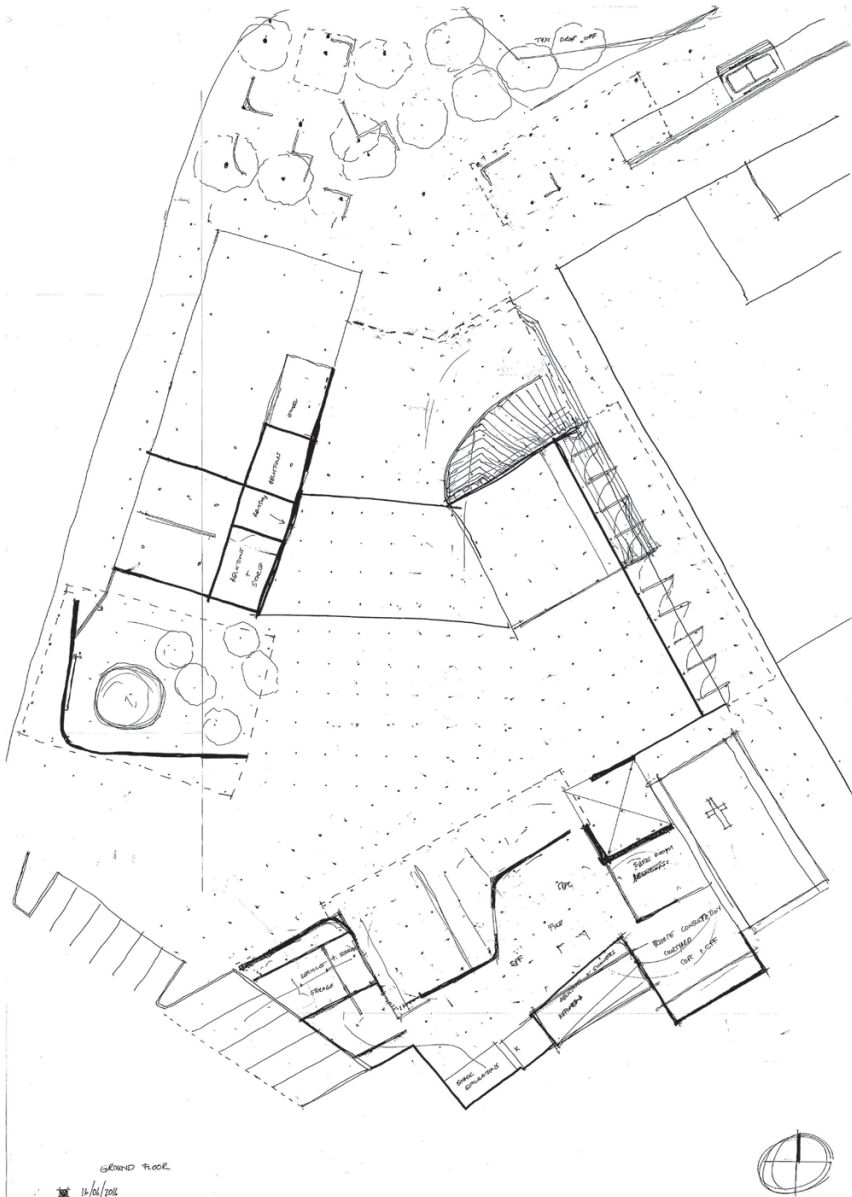

Figure 87:3x3meter grid used to control both building and landscape (Author 2016).

To create order in composing the architecture, two grid systems on different axes are used to constrain and structure the buildings and the relationship to the public spaces.

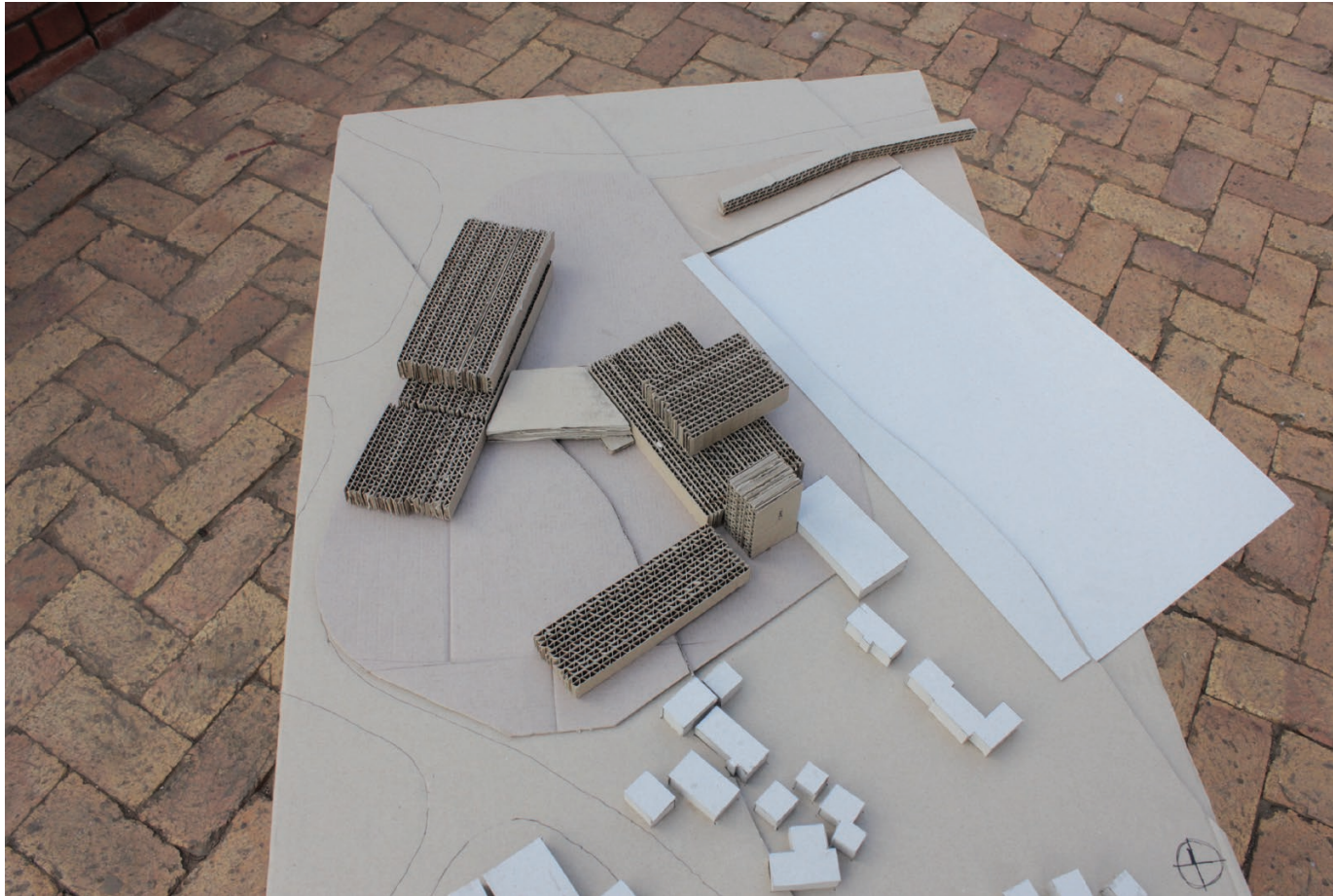

Figure 88: Massing model. (Author 2016)

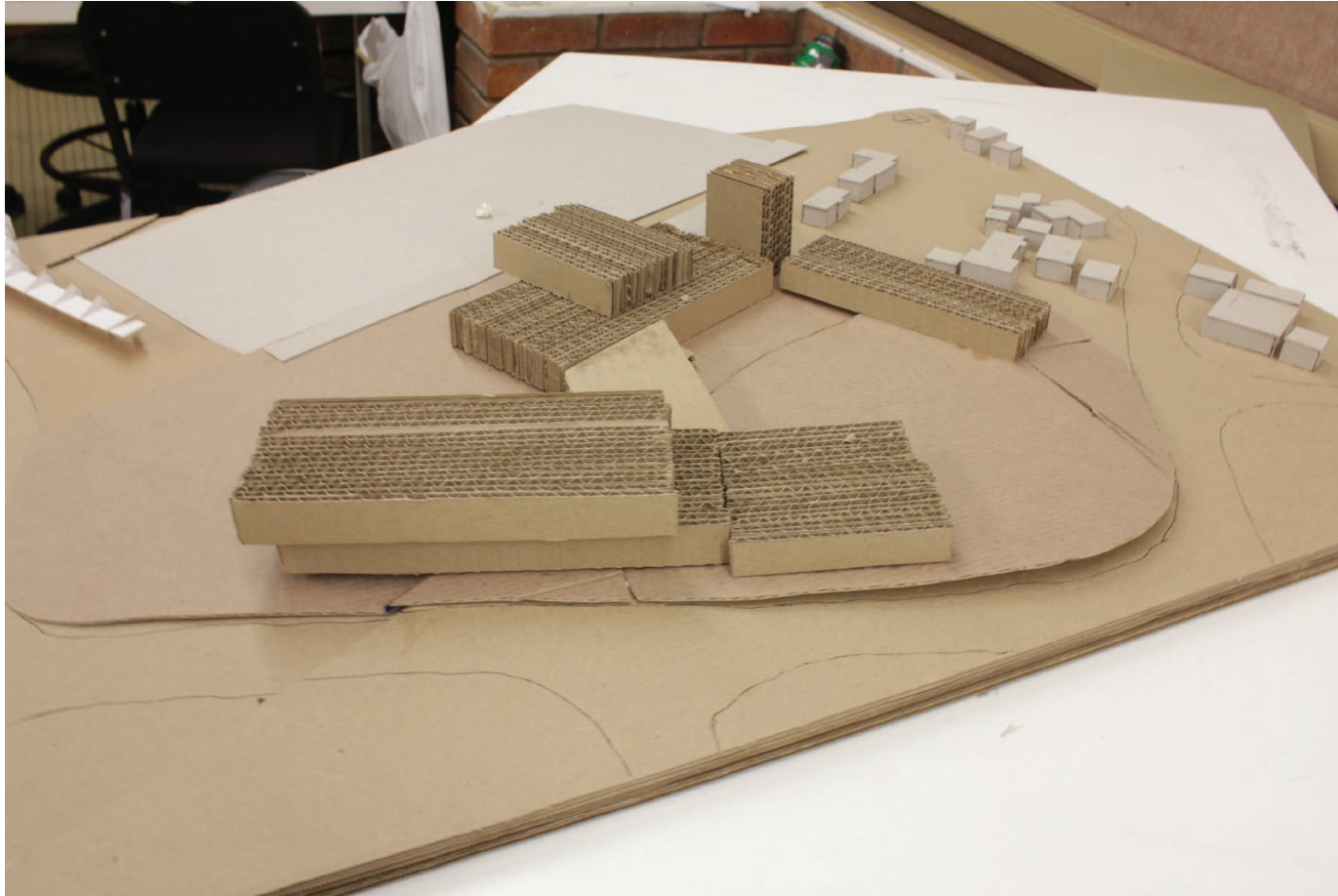

Figure 89: Massing model. (Author 2016)

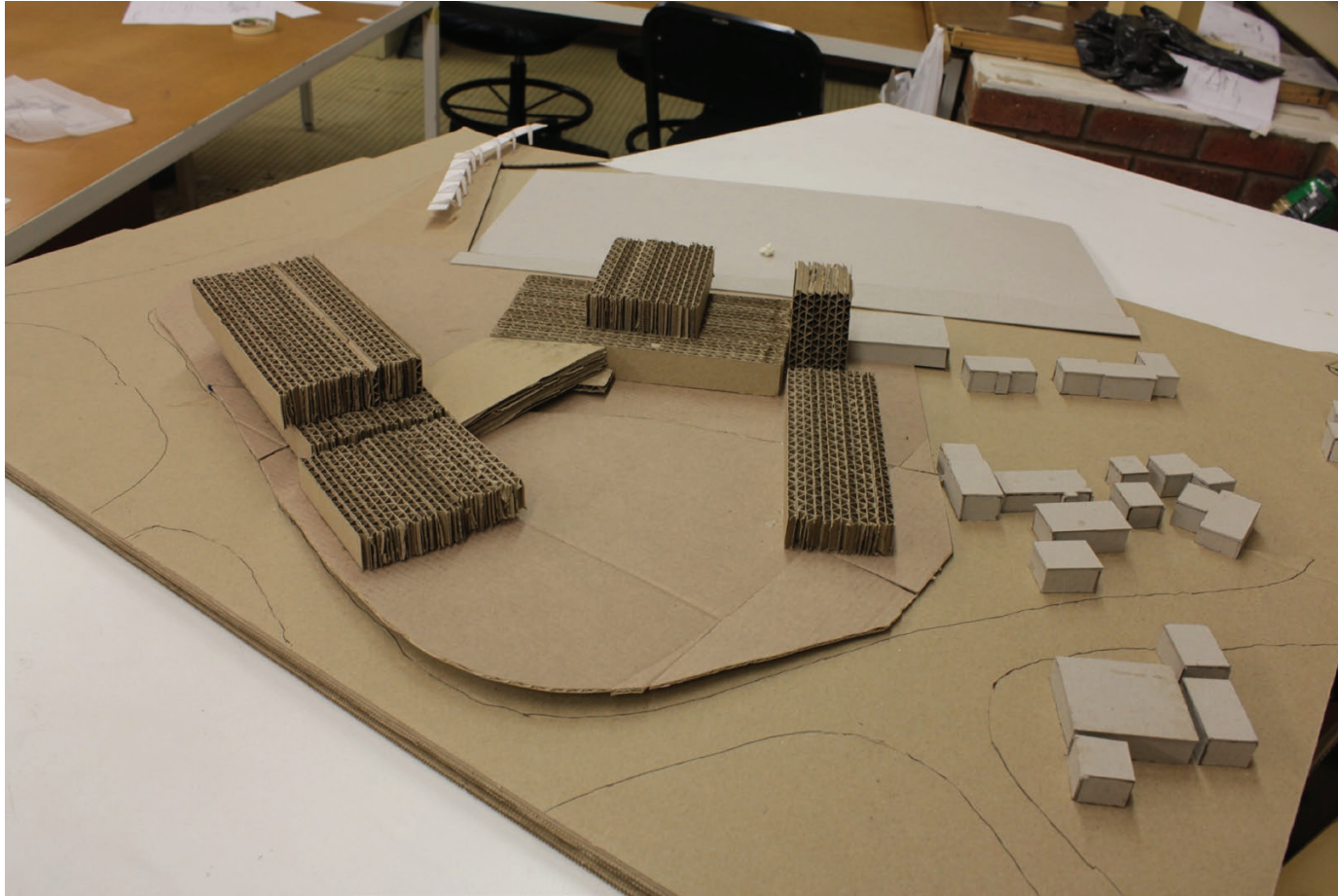

Figure 90: Massing model. (Author 2016)

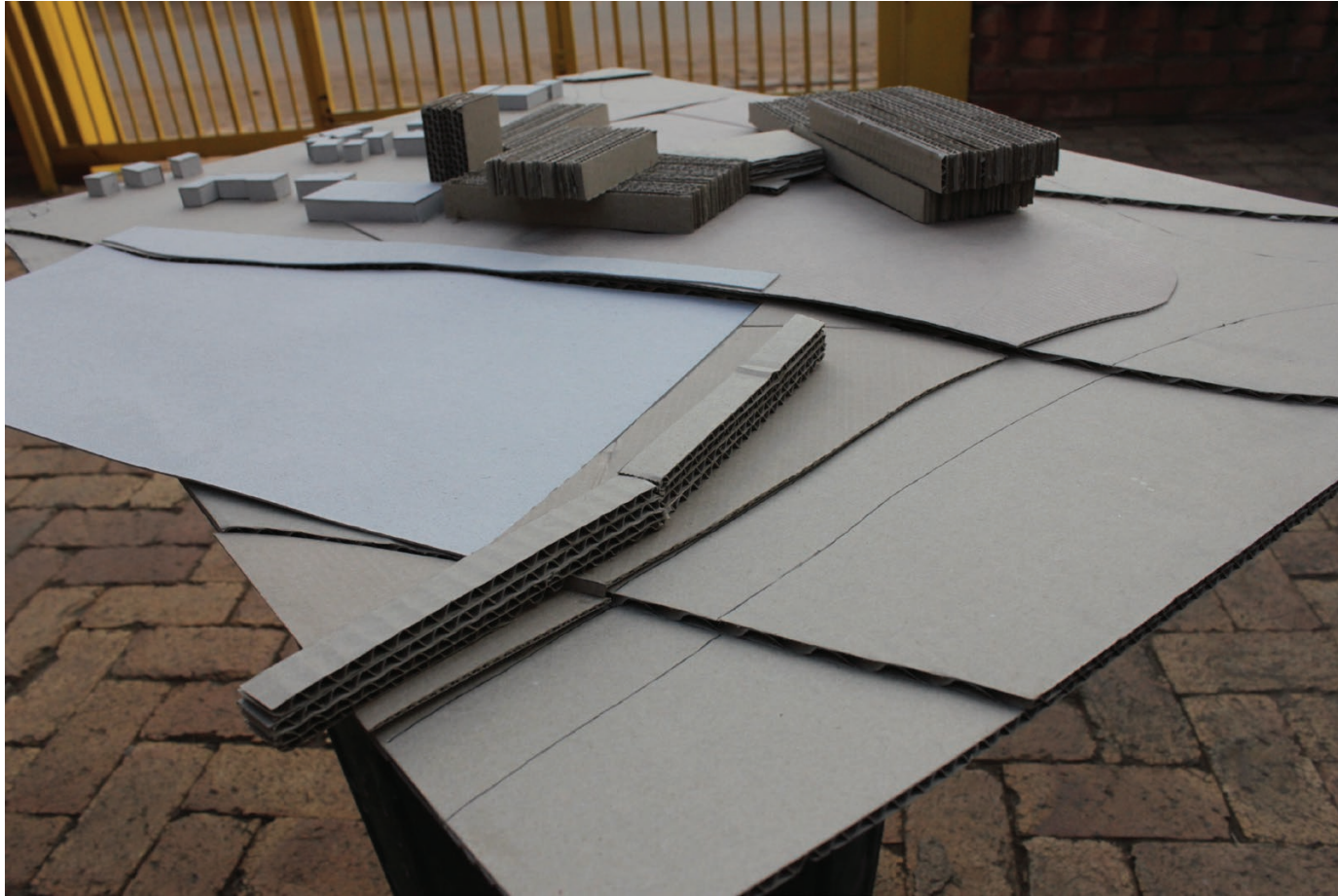

Figure 91: Massing model. (Author 2016)



Figure 92: Site Plan (Author 2016)



Figure 93: Ground floor plan. N.T.S (Author 2016).

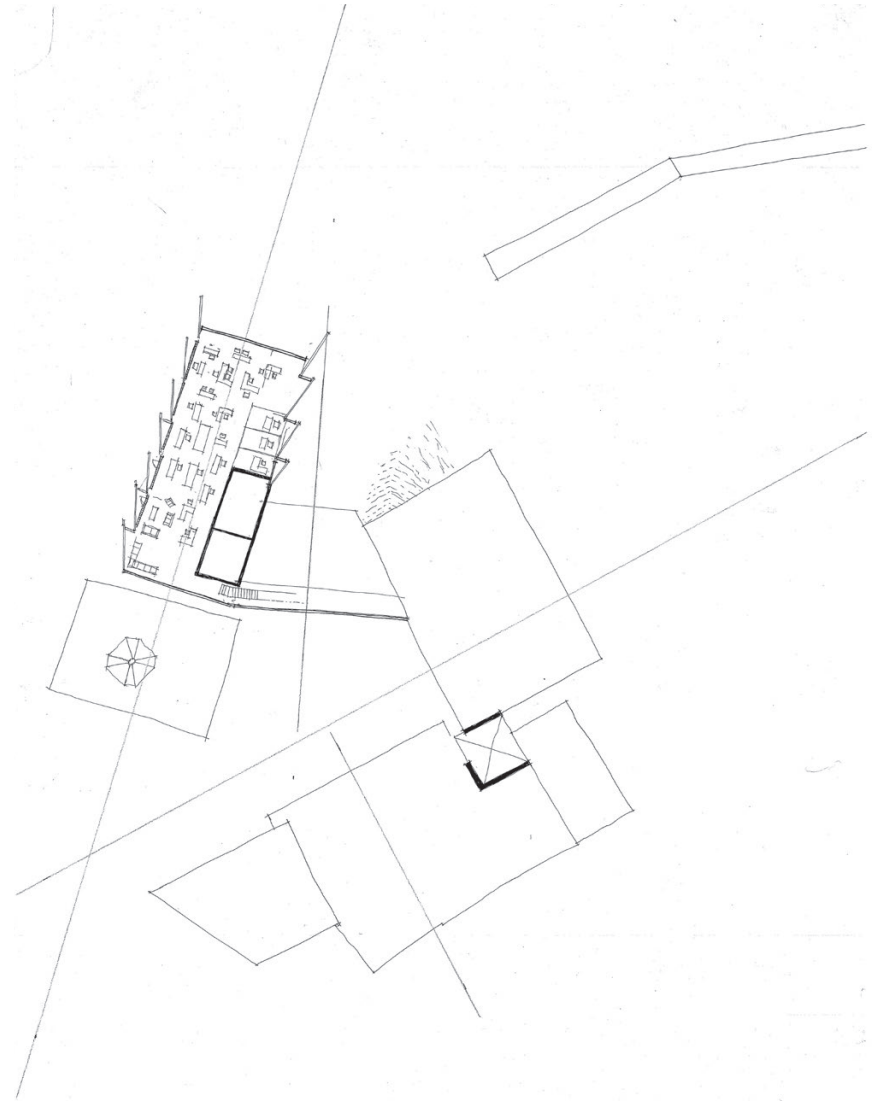

Figure 94: First floor plan (Author 2016).

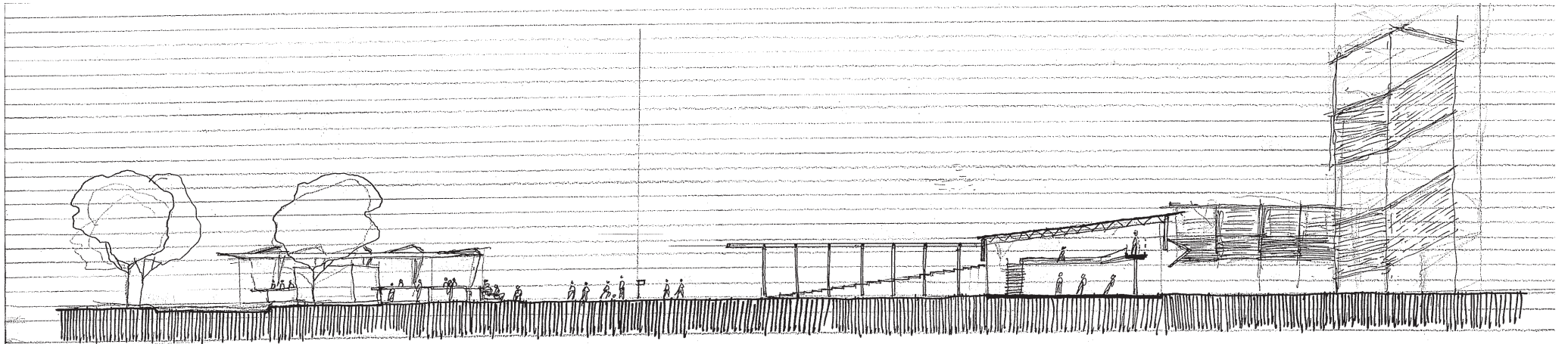

Figure 95: Section through the public spaces.(Author 2016).

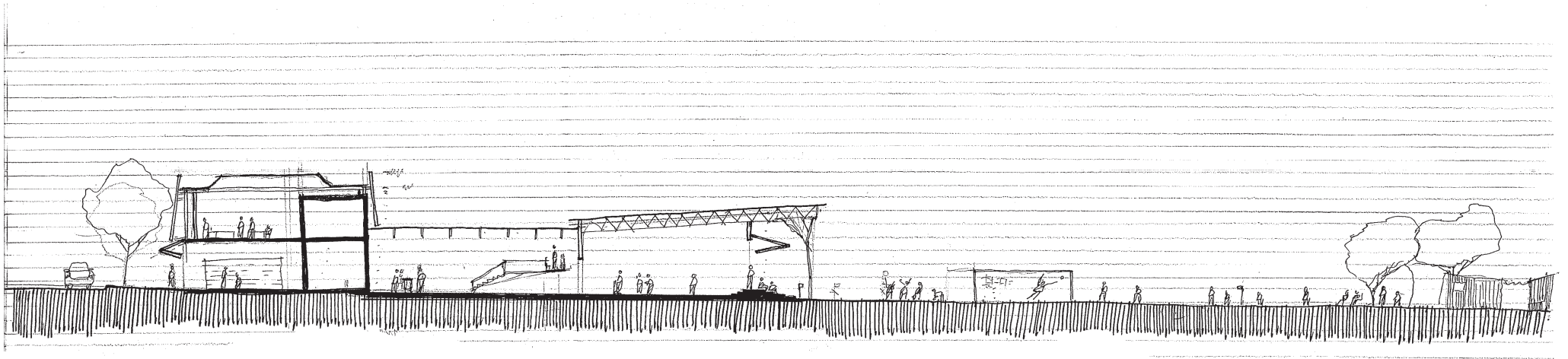

Figure 96: Section through the public spaces. (Author 2016).

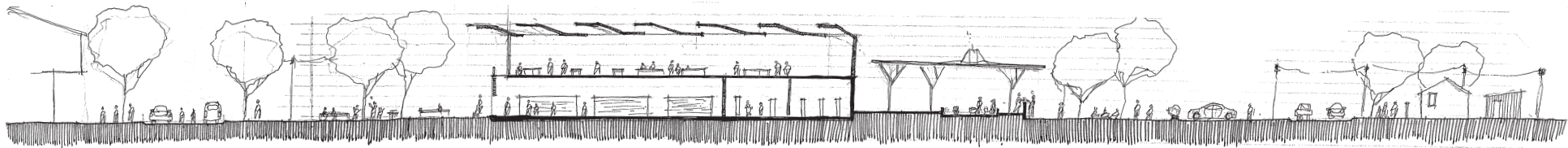

Figure 97: Sections through the building (Author 2016).

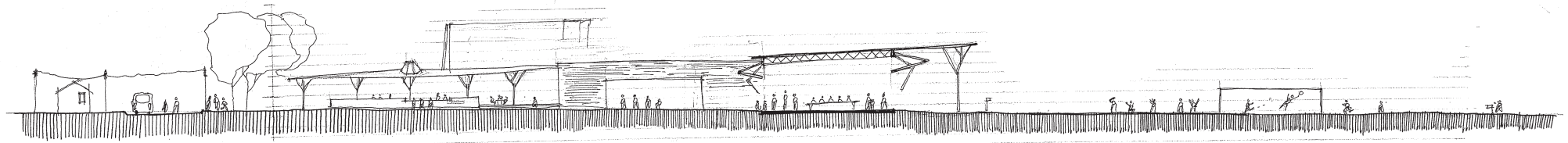

Figure 98: Sections through the building (Author 2016).

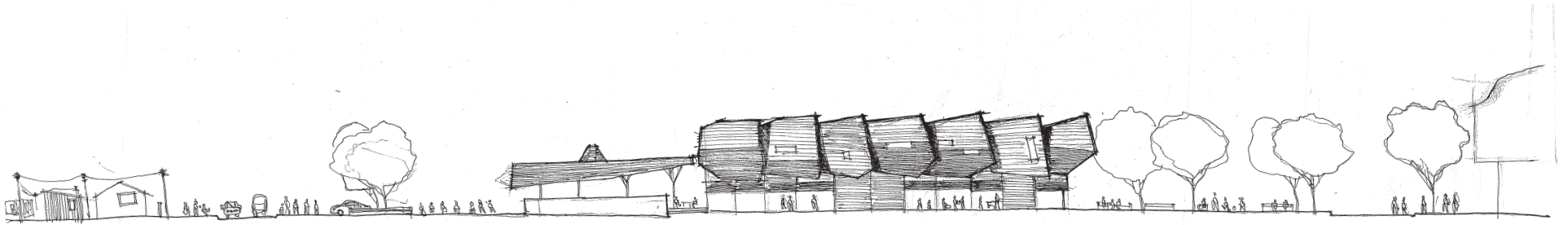

Figure 99: Elevations of building within context (Author 2016).

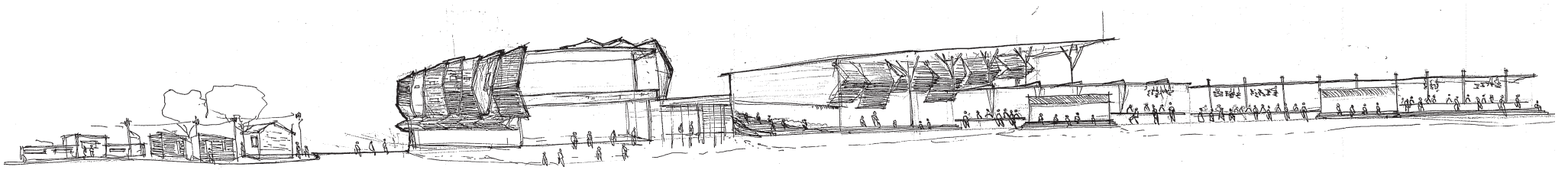

Figure 100: Elevations of building within context (Author 2016).

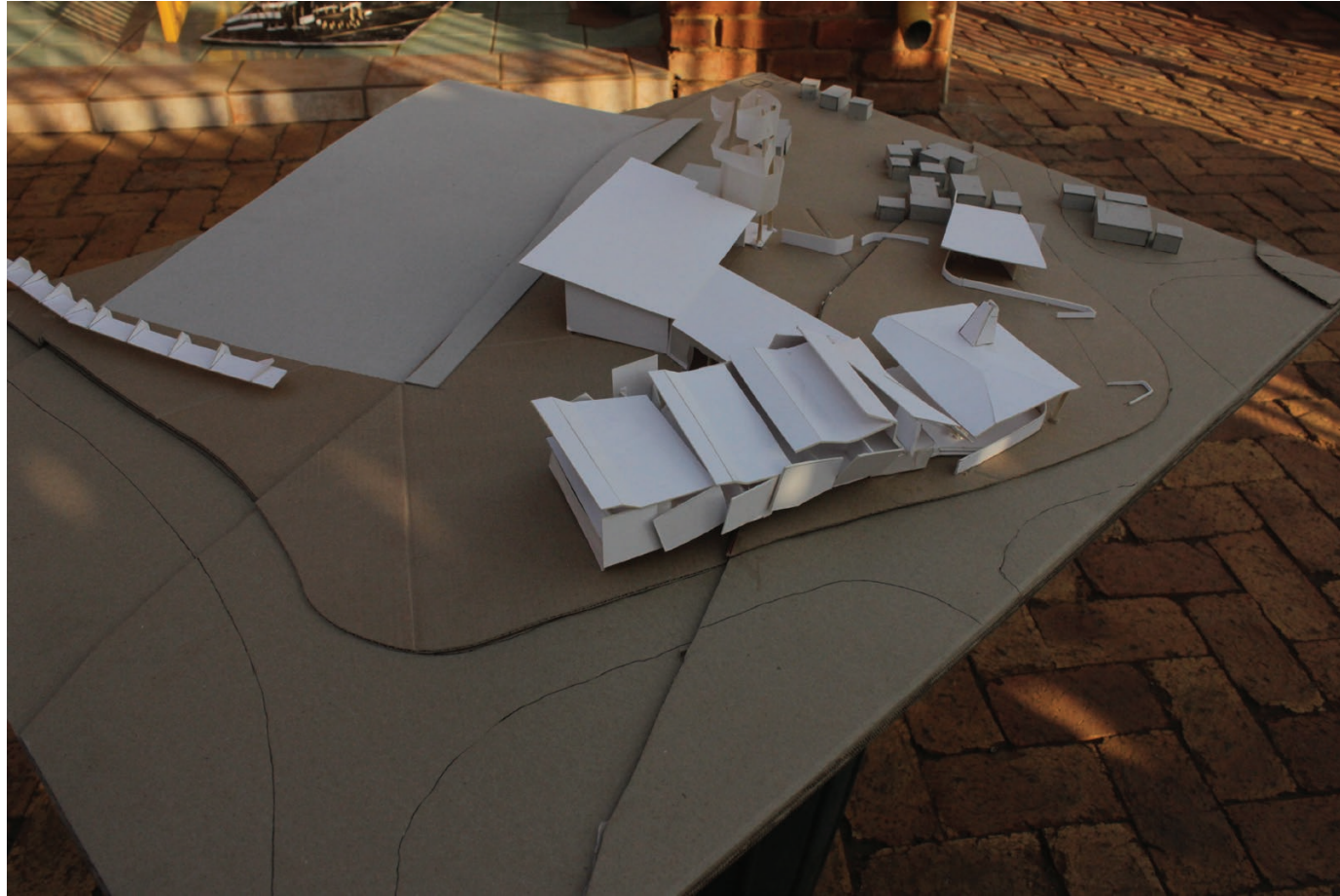

Figure 101: Marquette of building in the landscape. Aerial view (Author 2016).

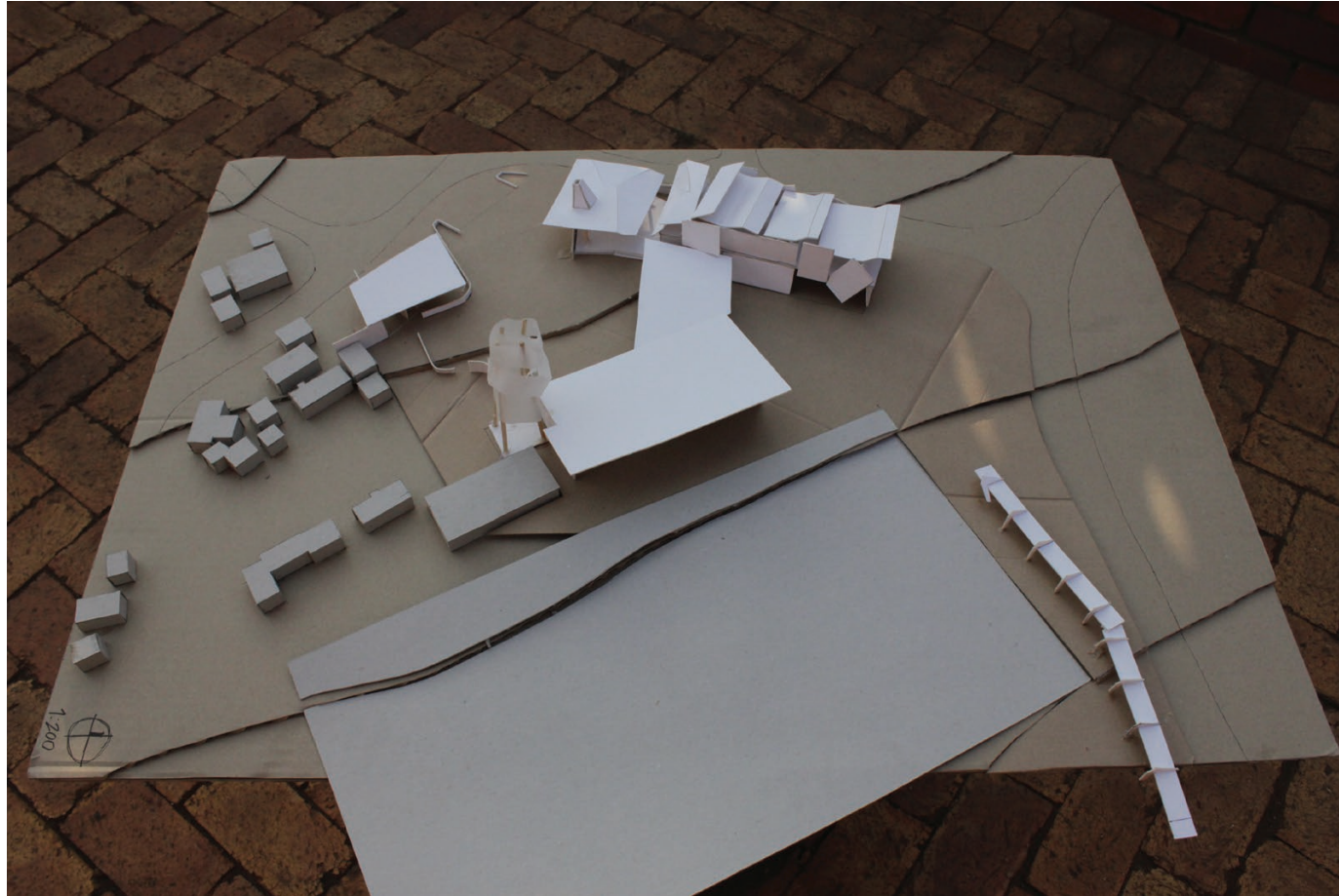

Figure 102: Marquette of building in the landscape. Aerial view from the soccer field (Author 2016).

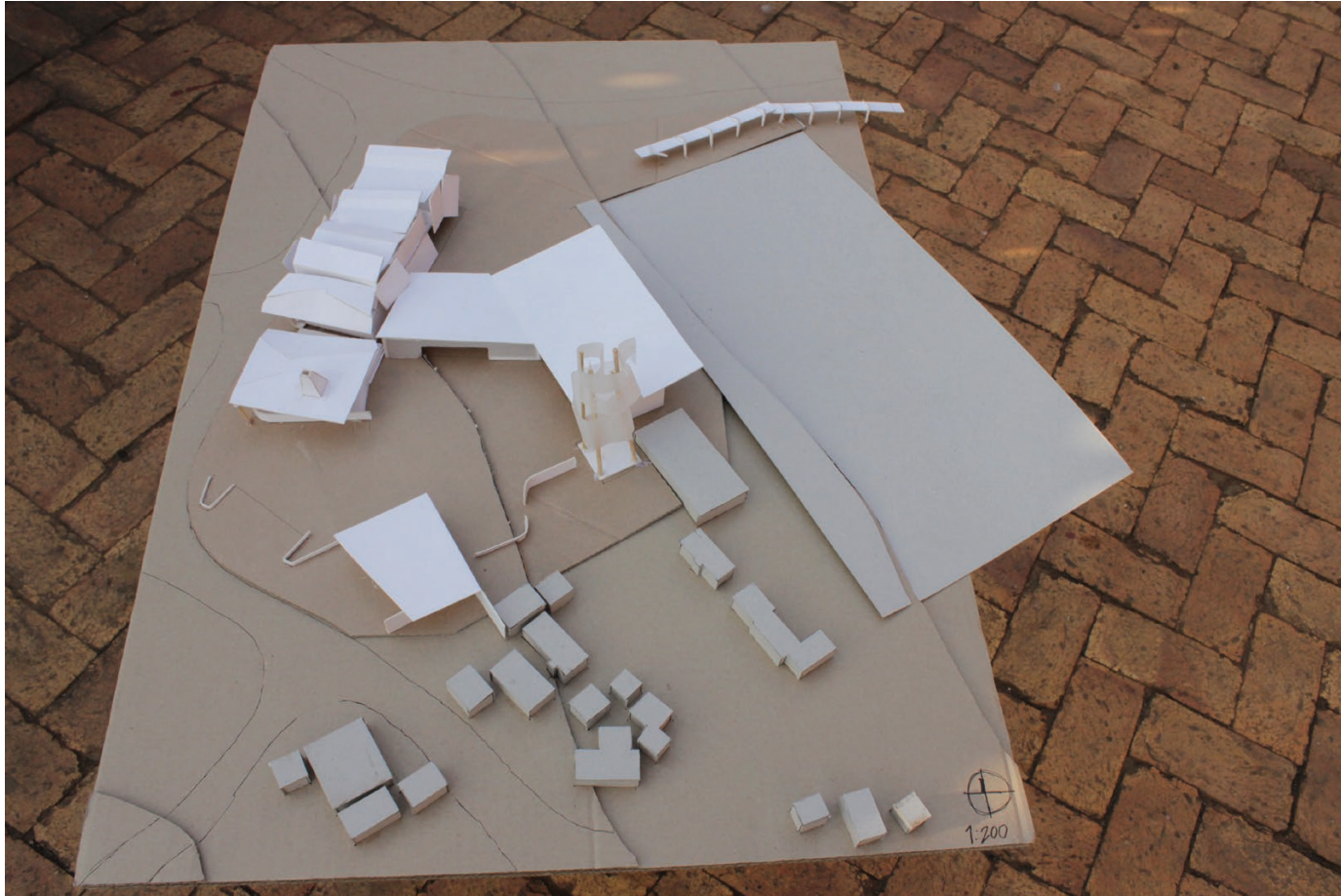

Figure 103: Marquette of building in the landscape. Aerial View (Author 2016).

The initial design achieved the following:

- Defining the street edges.
- Defining the 3 public spaces.
- The buildings defining the public spaces are addressing the programmes of the public through the buildings programmatic layout.

The design failed in the following ways:

- The scale of the building failed to address the design principle of negotiating between civic and residential scale.
- The language of building at this stage was not appropriate for the context. Through its architectural form and proposed materials.
- The space allocation proved too much for the programme and therefore had large uncontrolled spaces.

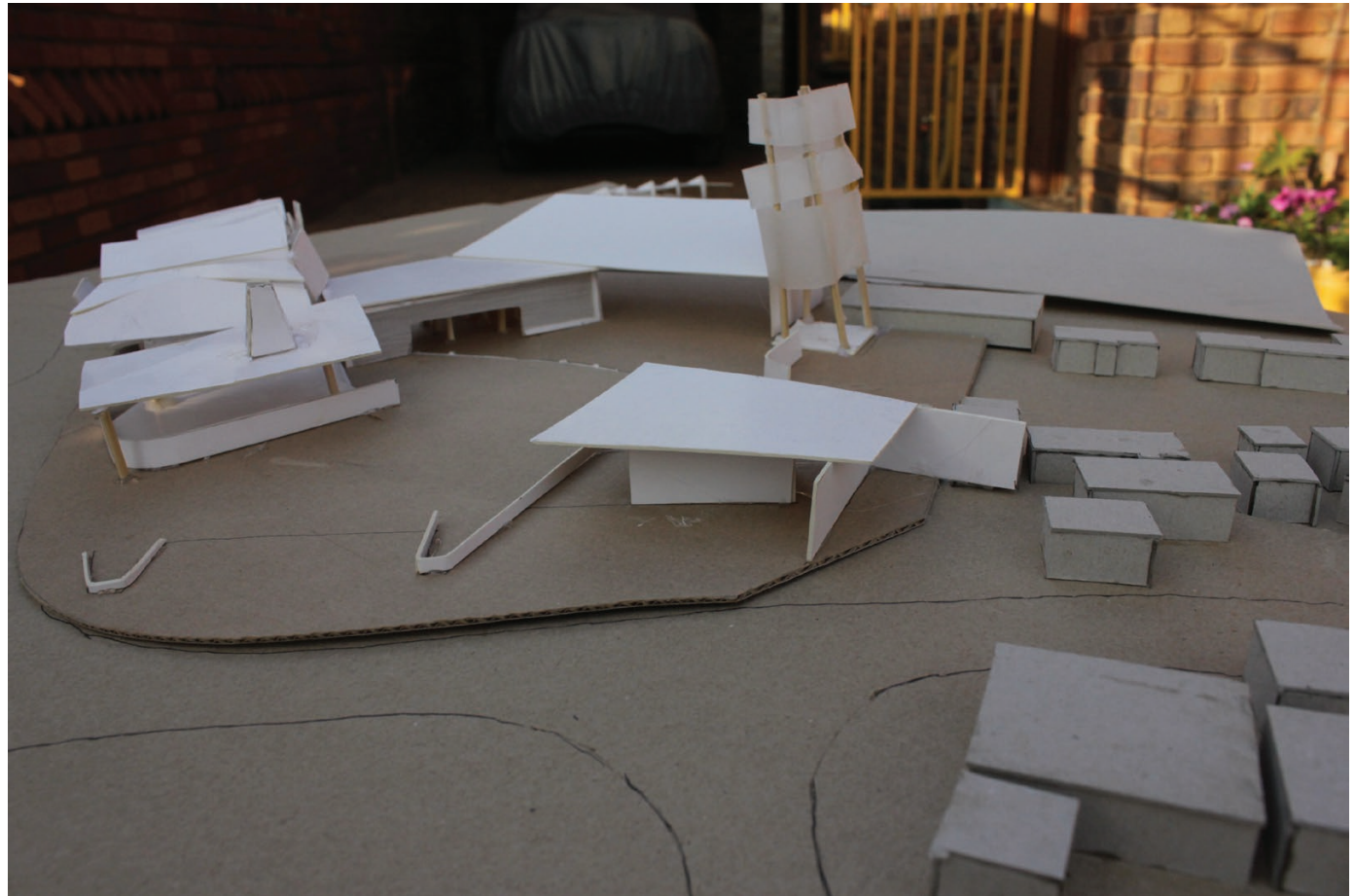

Figure 104: Marquette of building in the landscape. View from residential side of the building. (Author 2016).

7.4 DESIGN ITERATION

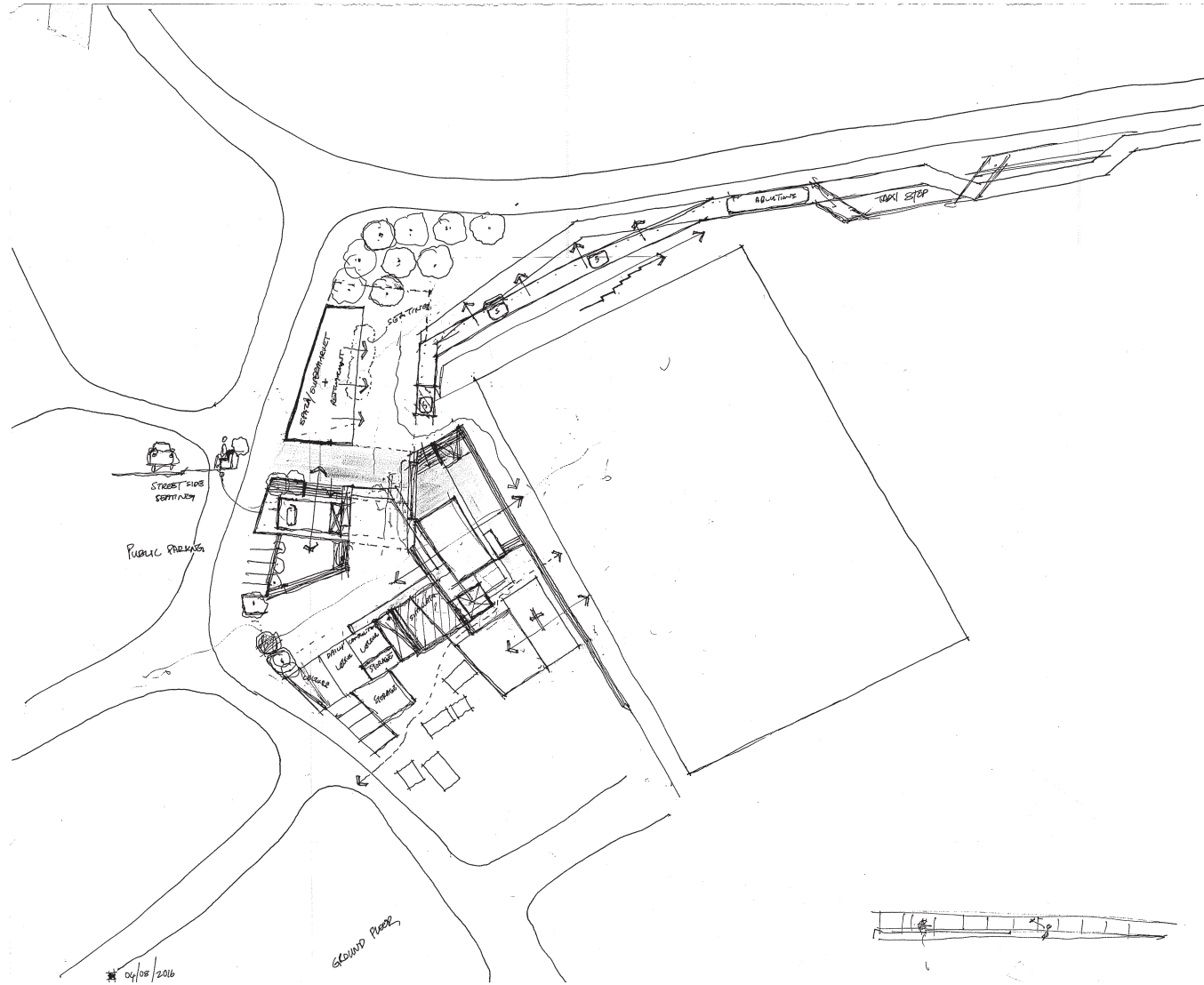

Figure 105: Layout and scale of buildings are redesigned to achieve the initial intentions. (Author 2016)

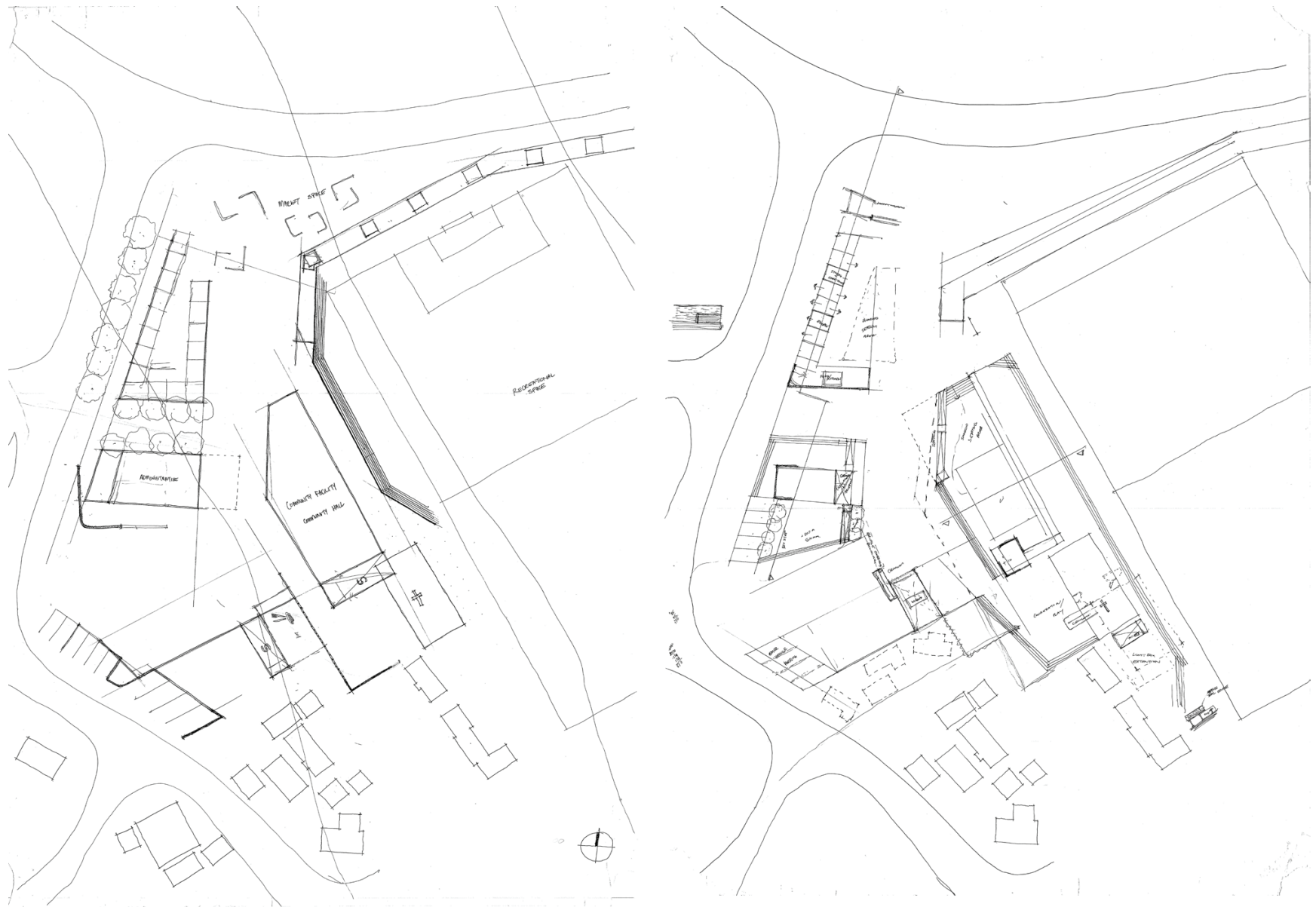

Figure 106: Site plan on the left and ground floor plan iteration on the right (Author 2016).



Figure 107: Investigating thresholds between the building and the landscape (Author 2016).

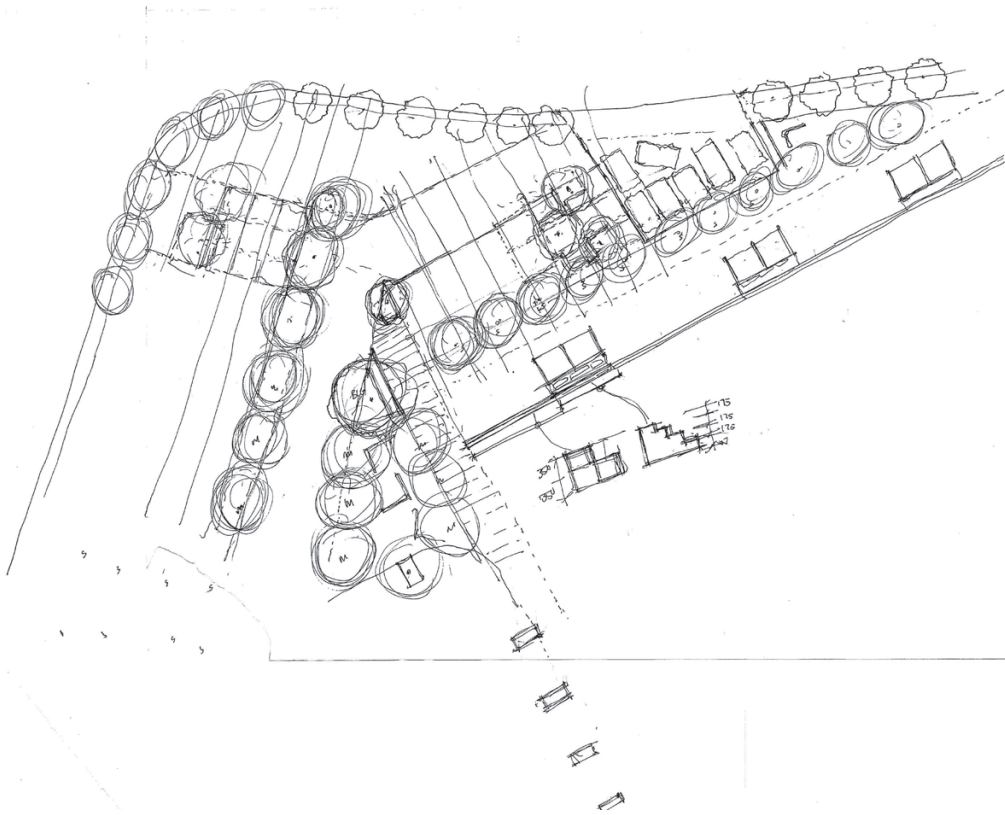

Figure 108: Redesigning the street edge of Hector Peterson Rd. and the thresholds to the market stalls (Author 2016).

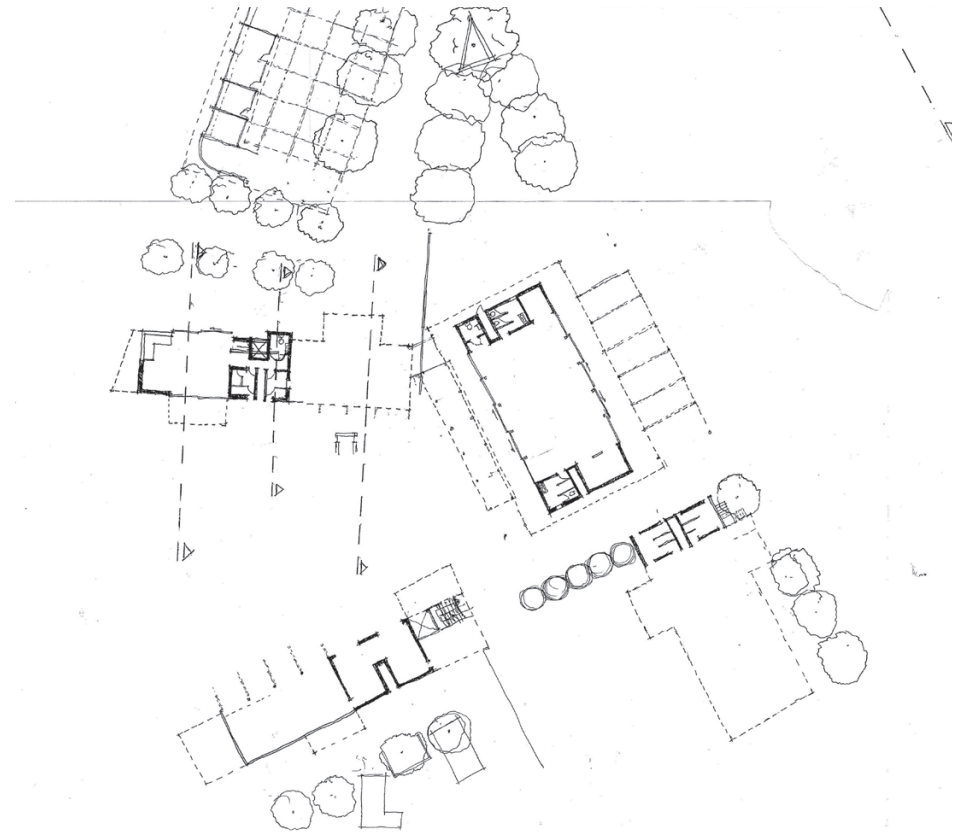

Figure 109: Sketch of landscape and roofs as thresholds. (Author 2016).

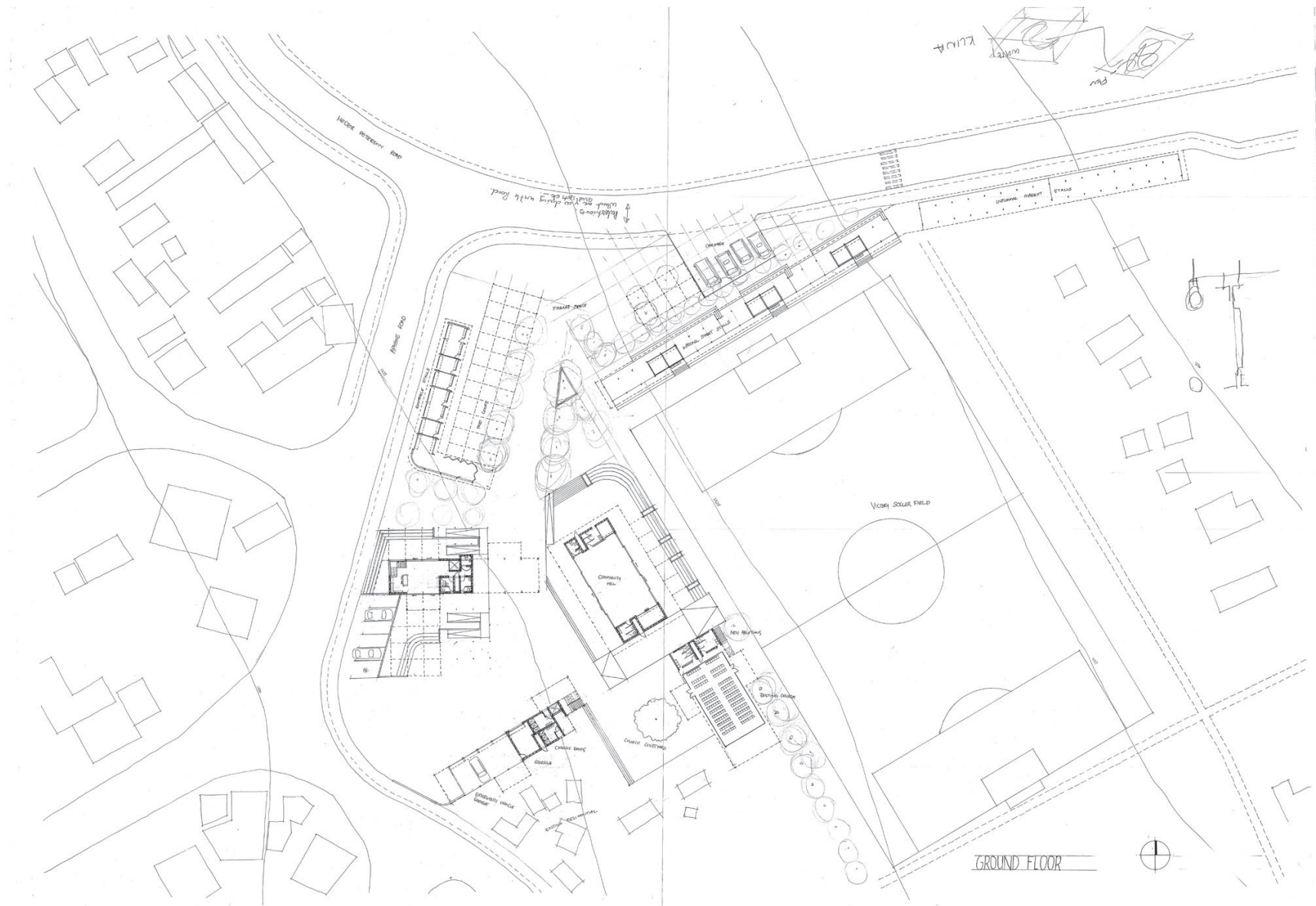

Figure 110: The iterated ground floor plan (Author 2016).

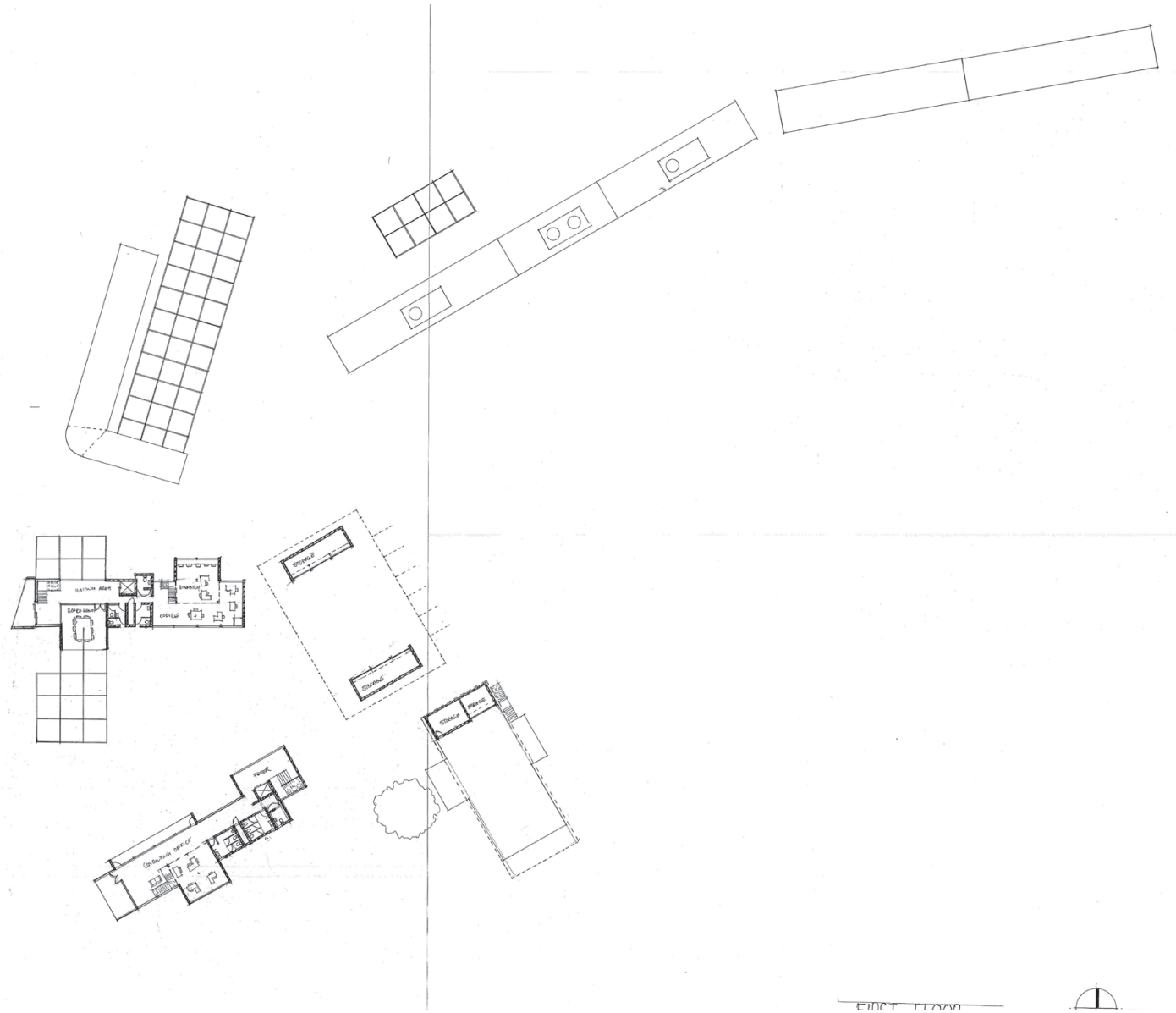

Figure 111: The iterated first floor plan (Author 2016).

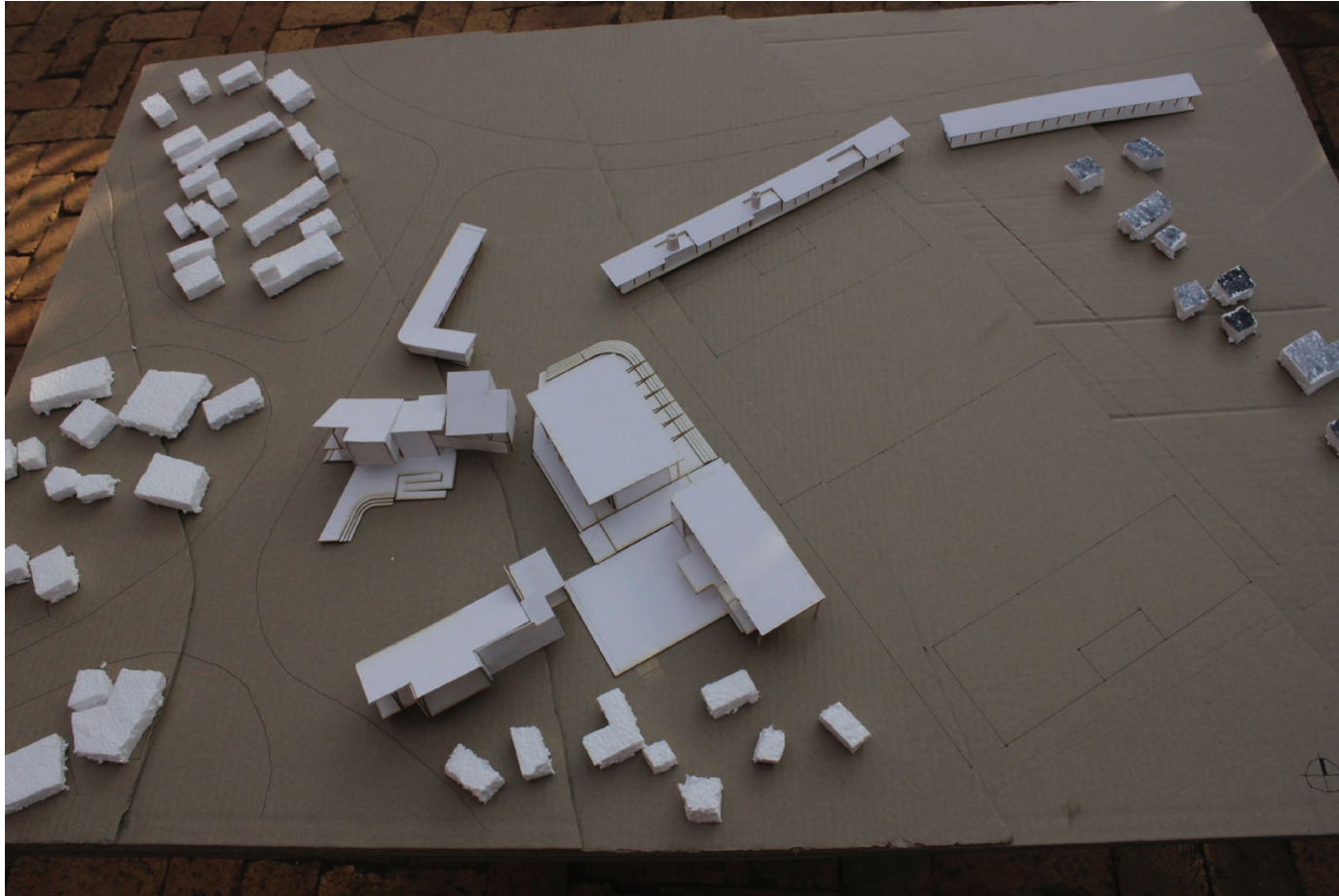

Figure 112:Marquette. Aerial View. The model shows the character of the architecture in relation to the space around it (Author 2016).

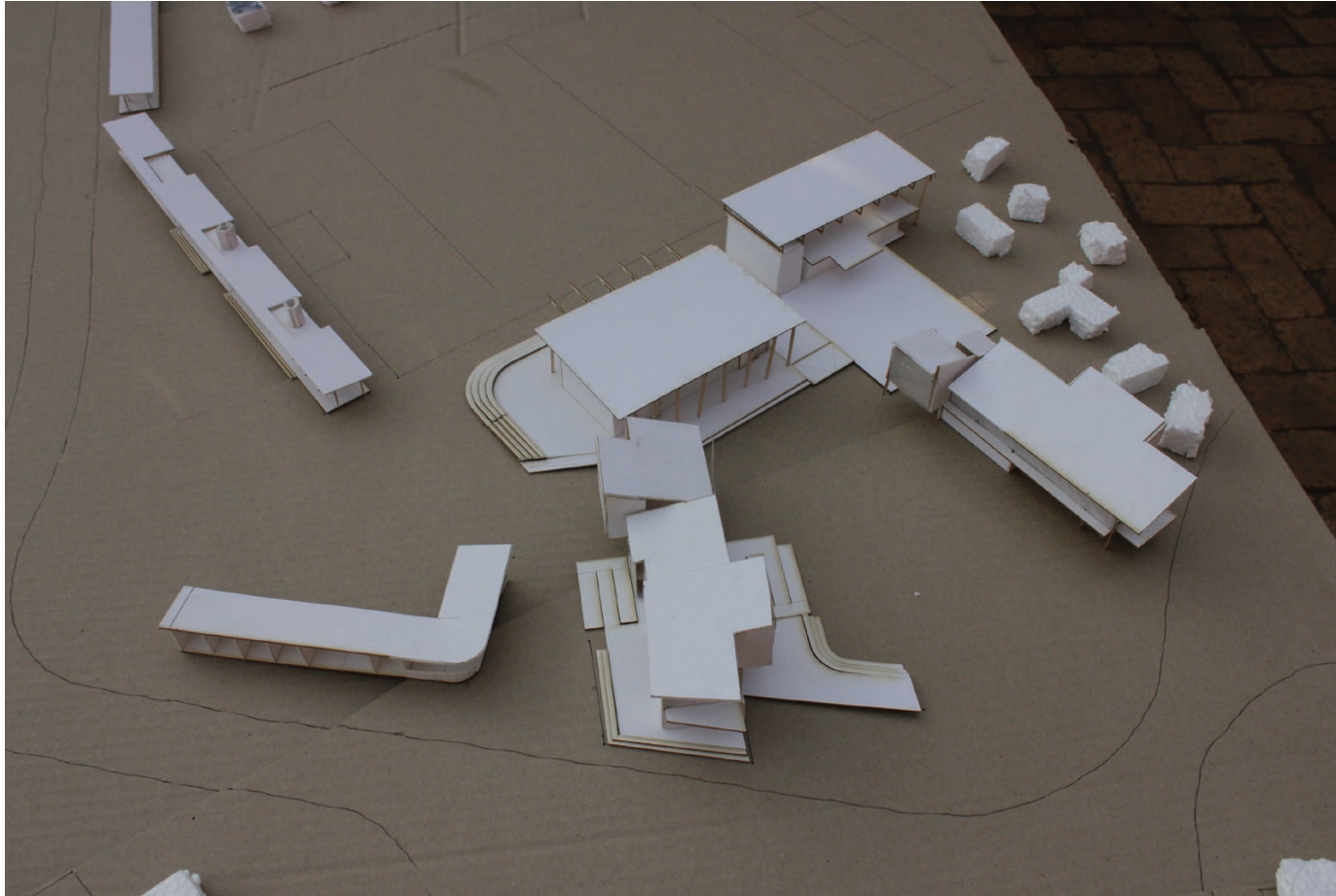

Figure 113:Marquette. Aerial View. The model shows the character of the architecture in relation to the space around it (Author 2016).



Figure 114:Marquette. Aerial view from the residential side of the site. The model shows the character of the architecture in relation to the space around it (Author 2016).

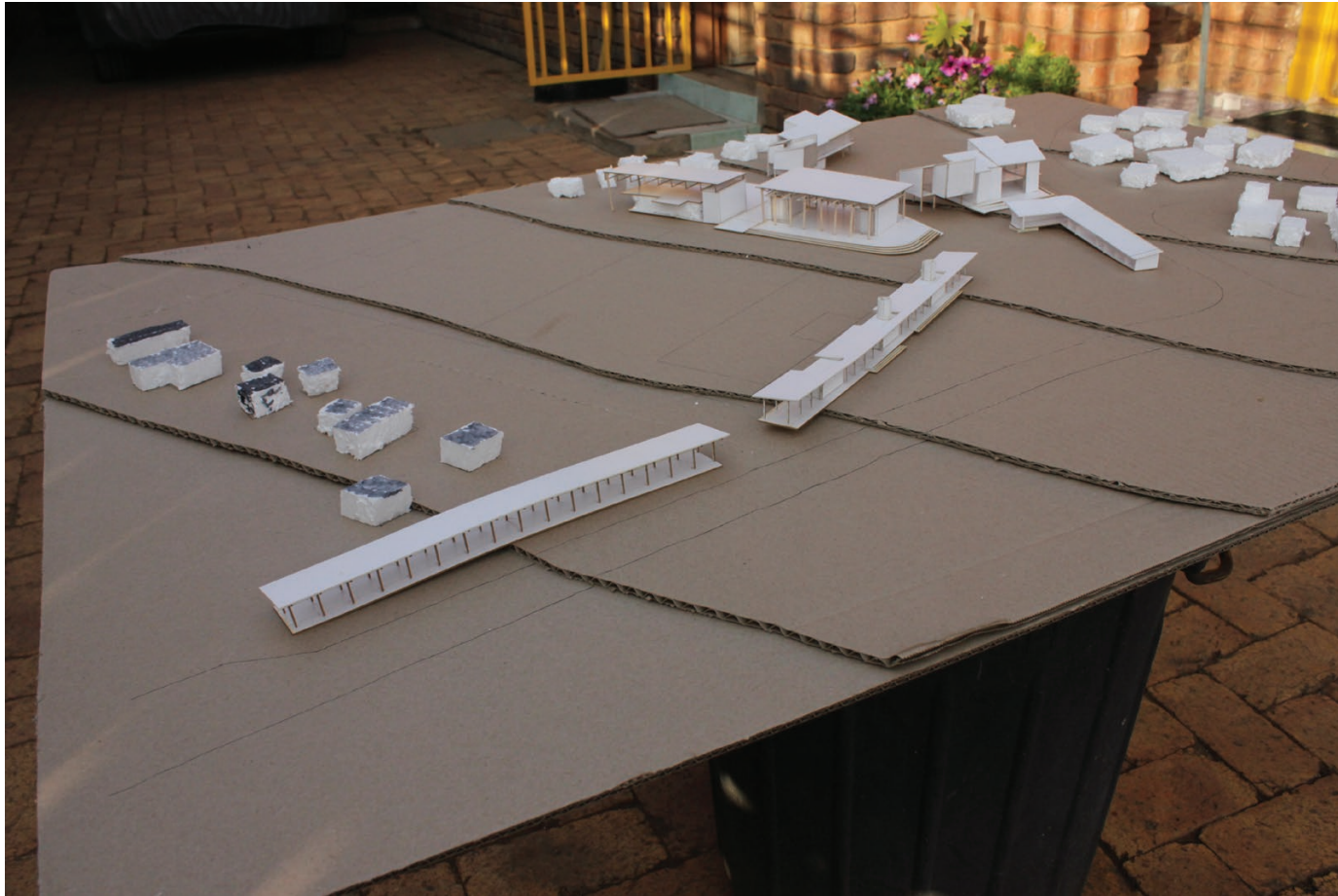

Figure 115:Marquette. View across Hector Peterson Road and the primary school. The model shows the character of the architecture in relation to the space around it (Author 2016).

The iteration of the initial design achieved the following:

- Defining the street edges.
- Defining the 3 public spaces.
- The buildings defining the public spaces are addressing the programmes of the public through the buildings programmatic layout.
- The buildings scale addresses the civic scale of the project but also the residential scale of the surrounding context.
- Thresholds between the building and the public space are created and they start a dialogue between the building and the landscape.
- The size / foot print of the building is more appropriate to the function of the project and the spatial requirements



Figure 116:Marquette. View from across the soccer field. The model shows the character of the architecture in relation to the space around it (Author 2016).

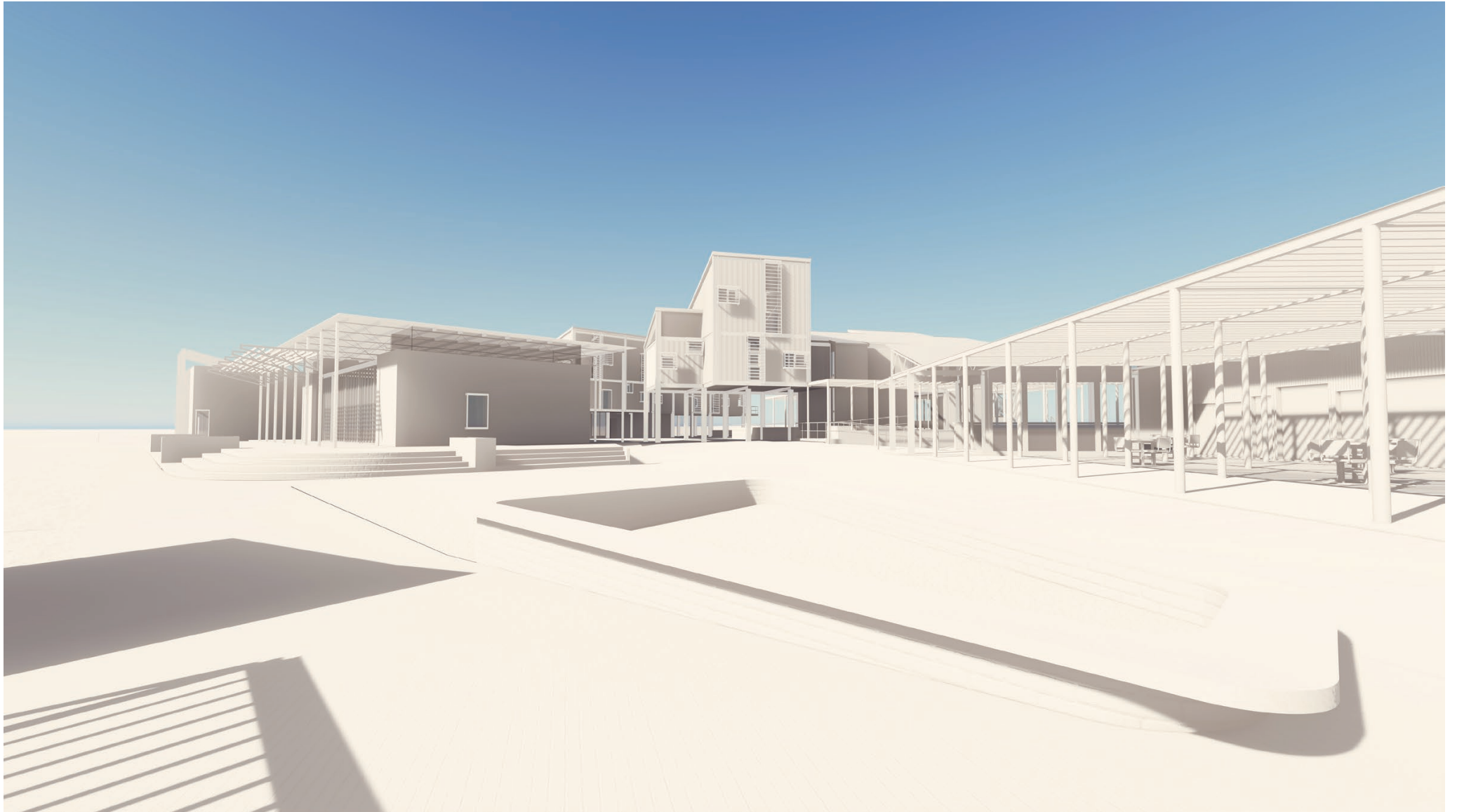

Figure 117:3D rendering as you enter from the Market space (Author 2016).

7.5 FINAL DESIGN

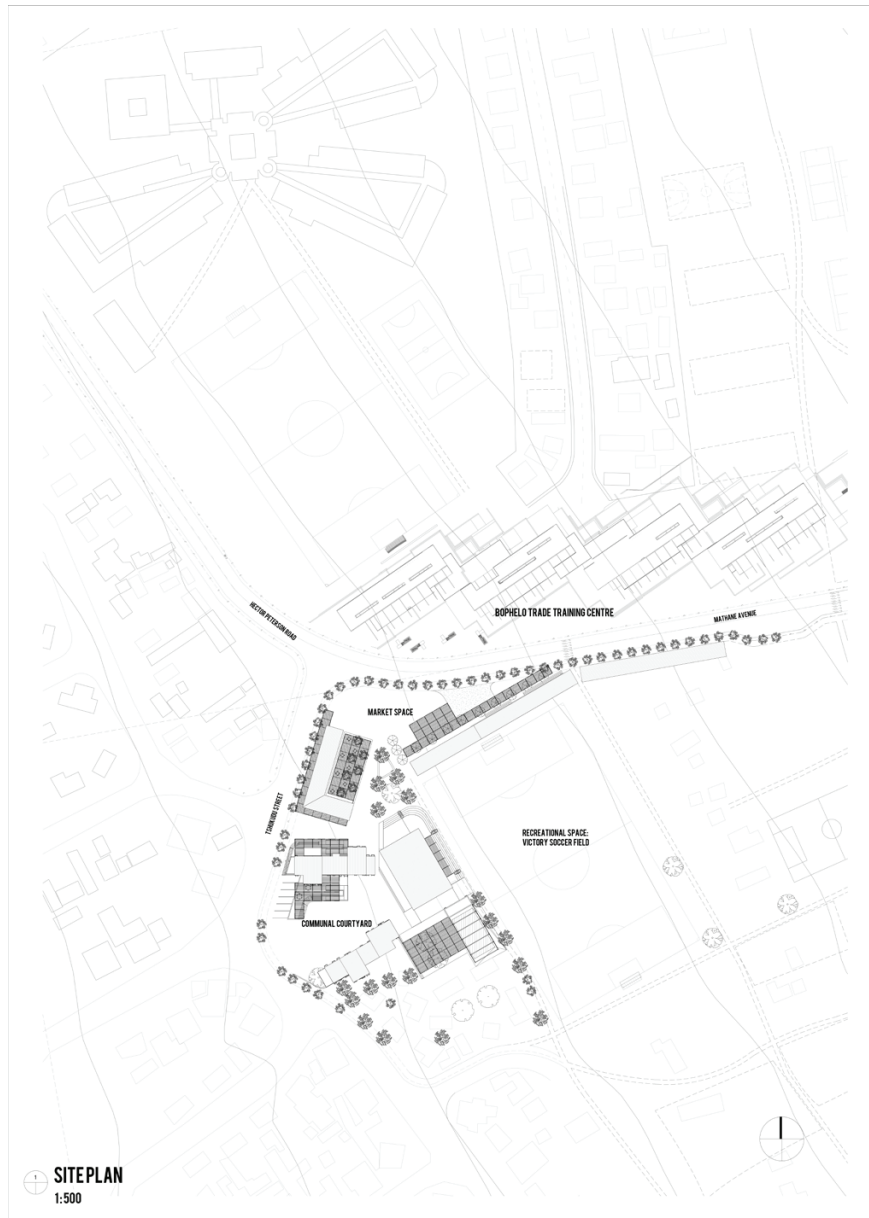

Figure 118: Site plan. 1:500 in presentation (Author 2016).



Figure 119:Ground floor plan . 1:200 in presentation. (Author 2016).

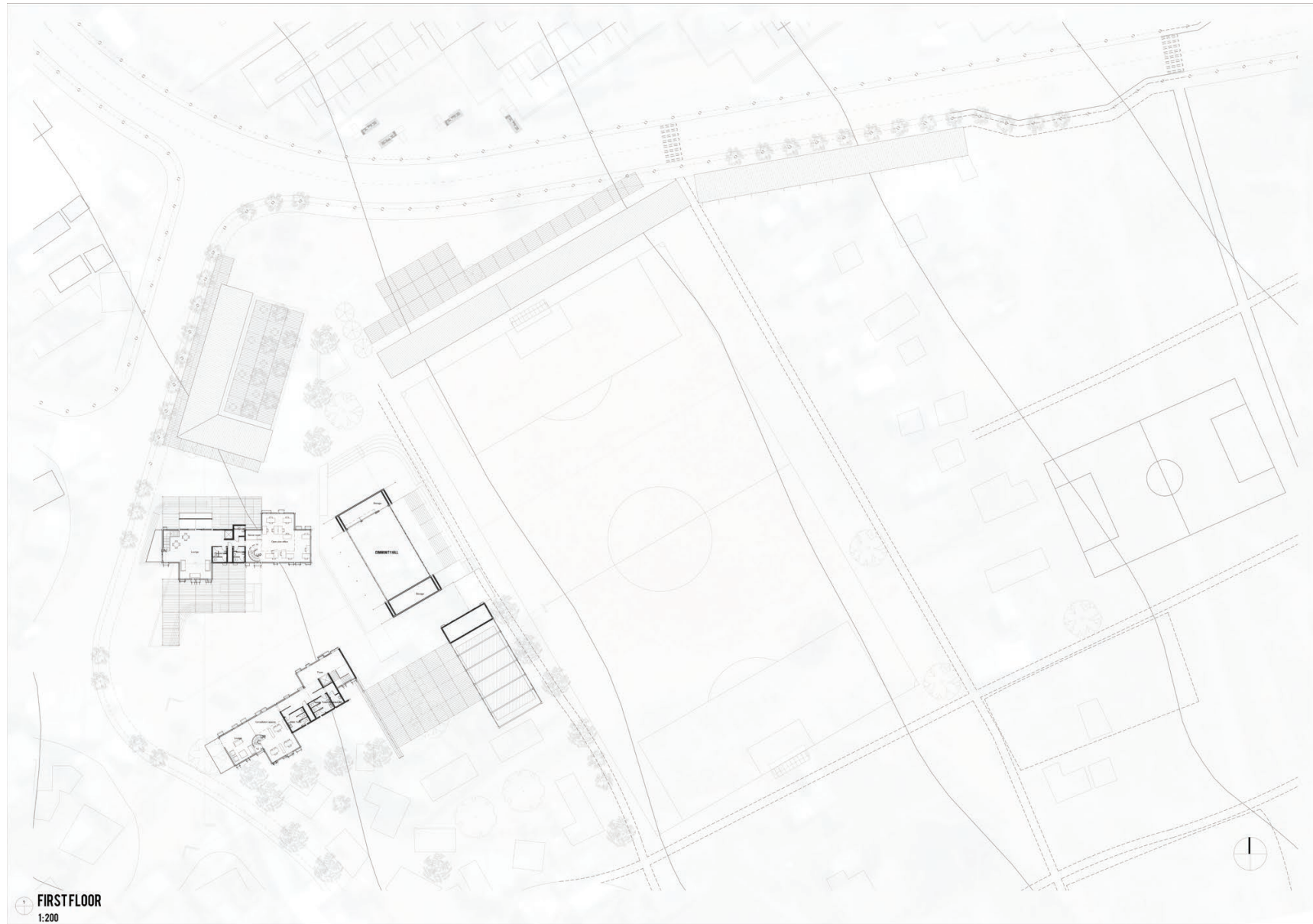

Figure 120:First floor plan. 1:200 in presentation (Author 2016).



Figure 121:3D rendering. View as you enter from the Market space (Author 2016).



Figure 122:Northern Street Elevation [Hector Peterson Road]. Clay rendering (Author 2016)



Figure 123:Northern Street Elevation [Hector Peterson Road] (Author 2016).

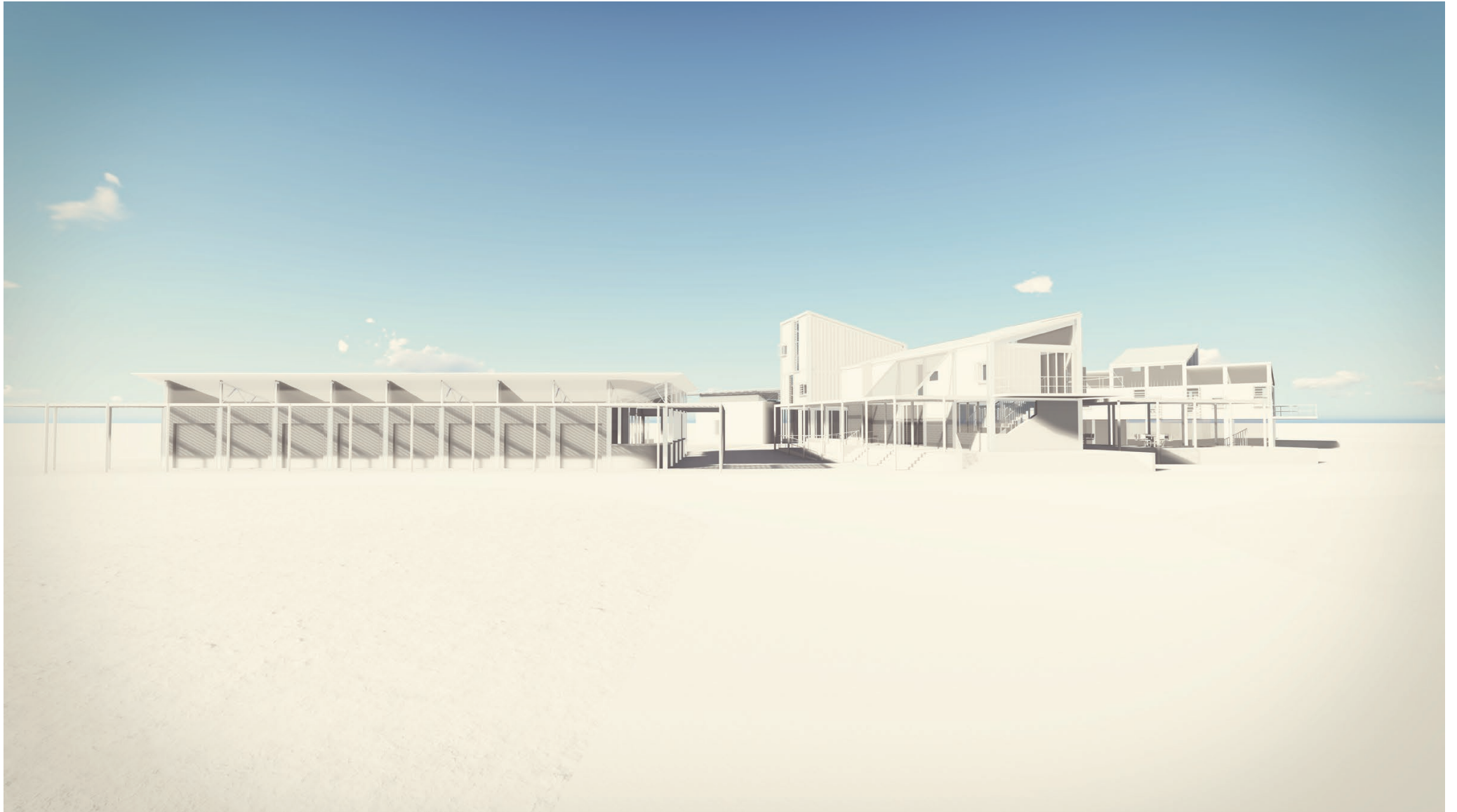

Figure 124: Western Street Elevation [Tshukudu Street]. Clay rendering (Author 2016)



Figure 125: Western Street Elevation [Tshukudu Street] (Author 2016).



SECTION B-B
1:100

Figure 126: Section through the Community Hall. 1:100 in the presentation (Author 2016).

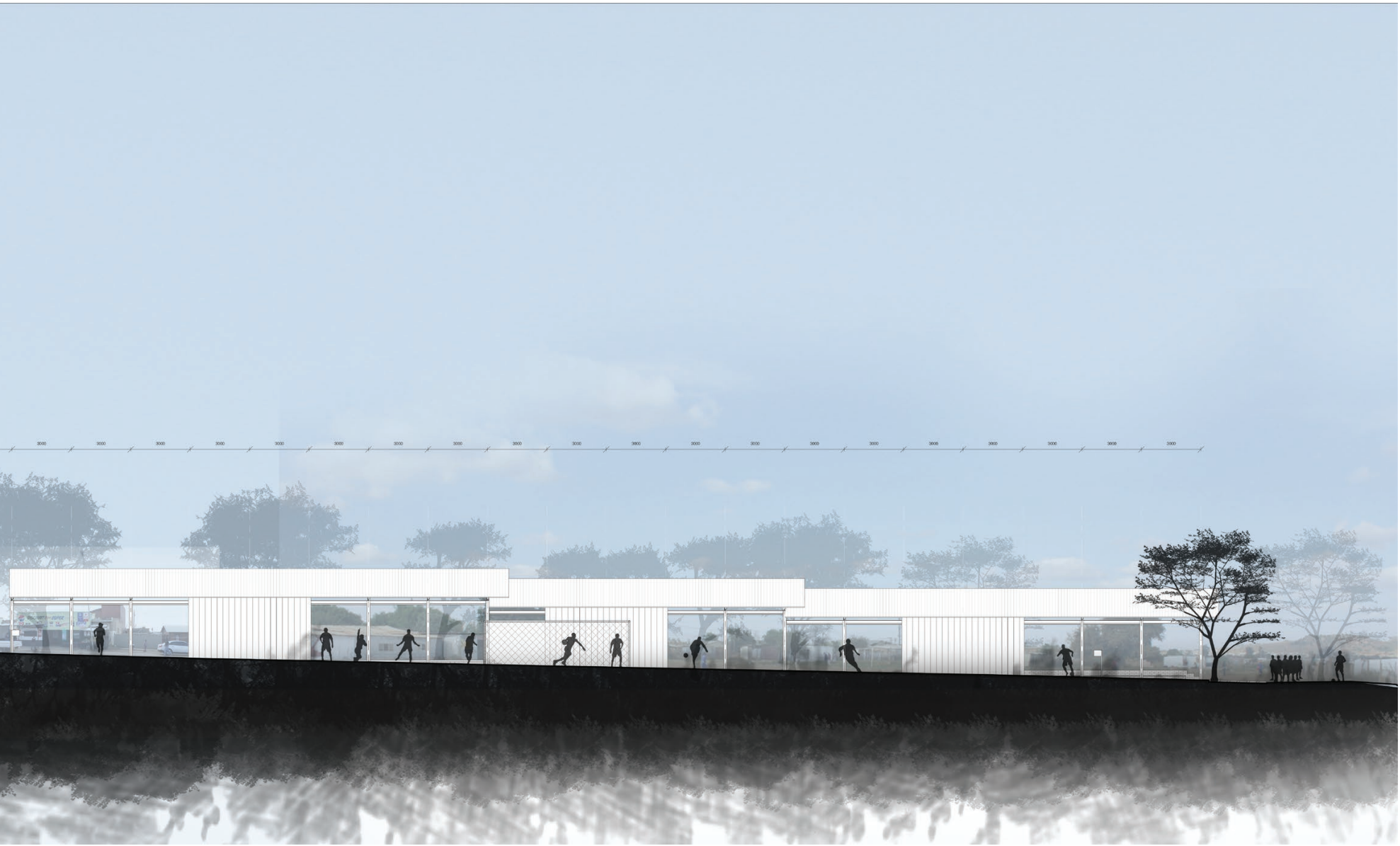
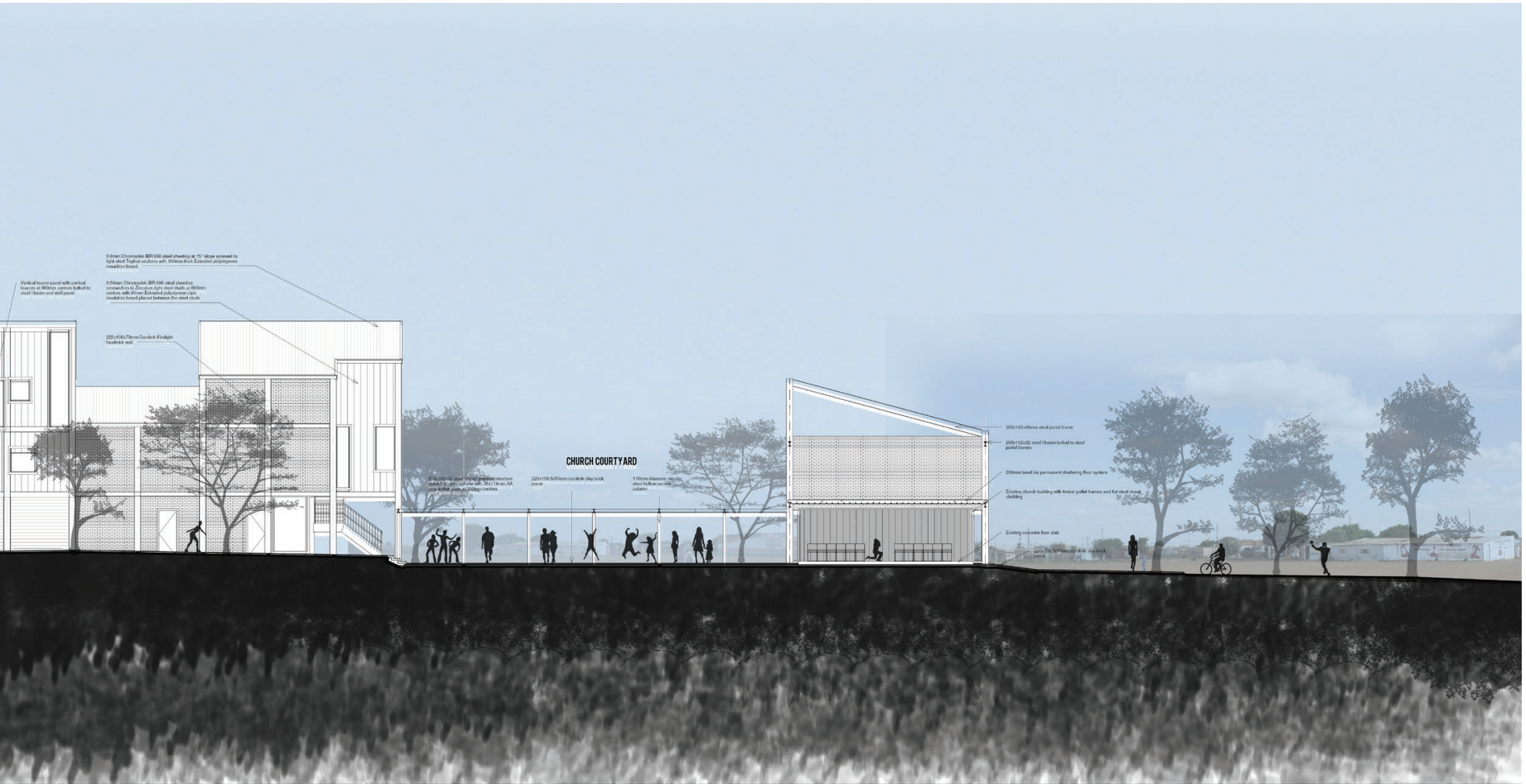



Figure 127: Section through the Church and the courtyard. 1:100 in the presentation (Author 2016).



8 TECHNICAL INVESTIGATION

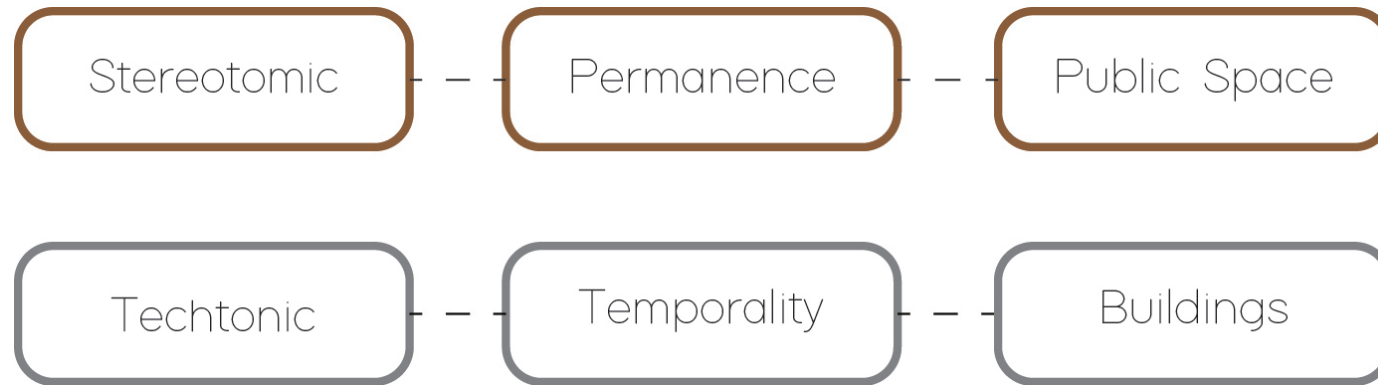

Figure 128:Tectonic concept. (Author 2016)

8.1 TECTONIC CONCEPT

The immediate context of the project is defined by a duality. There is a continuous influx of people traversing the state of permanence and temporality. The intention is to create an architecture that allows the public spaces to be defined with very limited choices of change and also an architecture that will allow for changes related to the changing needs of the growing community. The **public realm** will be defined as the most important component of the project and the community, as such, will be permanent. The buildings within the intervention will engage with the idea of temporality and as such become the ever changing background to the public realm.

8.2 TECHNOLOGICAL INTENTION

An investigation of the materials mostly used in the context led to the concept of engaging with the idea of permanence and temporality. The public realm and its platform will use stereotomic elements and materials such as concrete and masonry. The buildings will be tectonic, allowing for easier adapting of the building and increased visual and physical transparency.

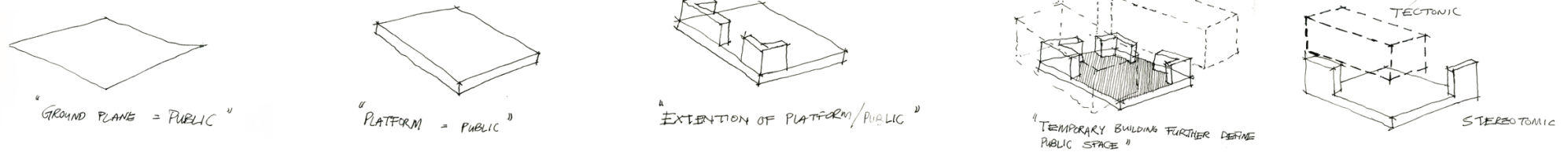

Figure 129: The platform and the process the building begins to grow from it (Author 2016).

8.3 STRUCTURAL INTENTION

The **platforms**, the podiums which form the primary structure of the buildings, which define the public space, will use masonry a material normally used in the vertical plane. The service core of the buildings will also be stereotomic and function as a structural component to the building and also as a structure through which adaptations may occur. The buildings will use steel and light gauge steel structures to reveal the makings of the building (material honesty) transparency and allow for adapting of the building. This will be based on 3x3 metre grid.



Figure 130: The RDP house and the shack, and the materials [Lusaka, Mamelodi] (Author 2016).

8.4 LEARNING FROM THE CONTEXT

Understanding the temporality and permanence duality in Lusaka becomes paramount. It goes beyond understanding the social consequences of this duality and towards the technological consequences. There are two main building types, namely the RDP house and the shack.

The RDP dwelling being made up of masonry units symbolise permanence. This same material is taken further

and used to building even larger homes. The traditional shack is made up of a timber frame made from timber pallets and clad with steel sheeting. This building method is considered as a cheap and temporary way of building a house. The basic shack can be adapted to a growing family or for greater spatial needs. Building technologies from these two typologies are incorporated in the project.

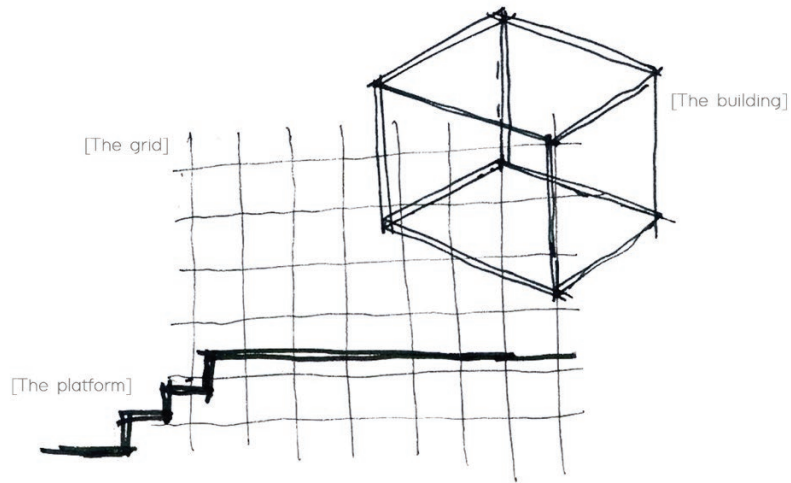

Figure 132: The relationship between the platform, the grid and the building. Tectonic concept (Author 2016).

The platform, which defines the public spaces, will be made of and use masonry and concrete. The intention is to recognise the public space as being permanent and therefore defining with a material symbolising permanence. The building will have a temporary aspect by allowing adaptable elements within the structural framework of the building.

The following architectural elements and their relationship will be investigated: The platform, the building and the grid. The grid becomes an important element as it functions on two levels:

The grid creates a dialogue between the building and the landscape. This is done by utilising the same grid size of 3x3 meter and using it to control space. The grid size remains constant to create a link between the landscape, the building and its components. This grid on two axes (figure 120) the first axis is for the market and recreational space. The second axis is for the communal space. The public spaces and relative buildings respond to these axes.

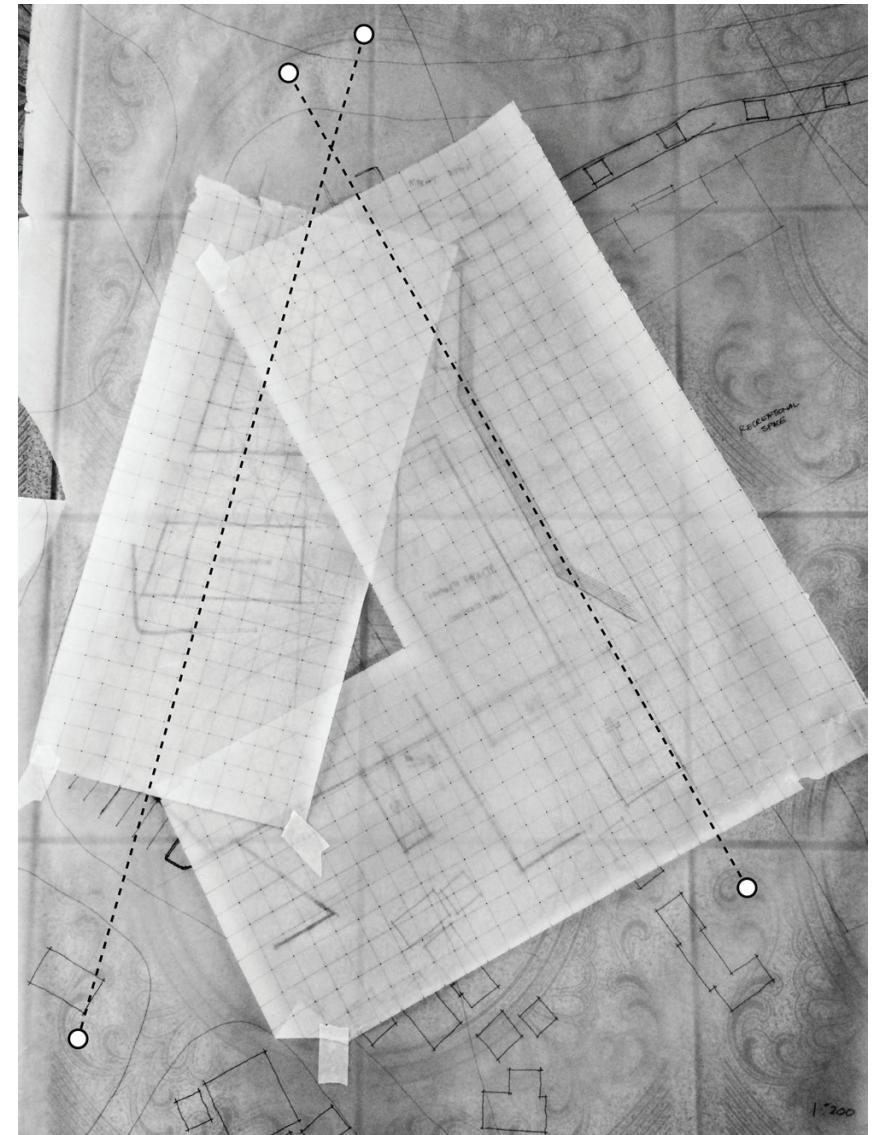

Figure 131: Grid and Axes the building layout and structure are based (Author 2016).



[Alternative energy generation]

8.5 SERVICES AND SUSTAINABILITY

Alternative ways of producing electricity are employed in the building. The cell module will be extracted from a traditional solar PV panel and be used to create an architectural element that creates a threshold between the building and the landscape; and an element that produces electrical energy that is to be used in the building.

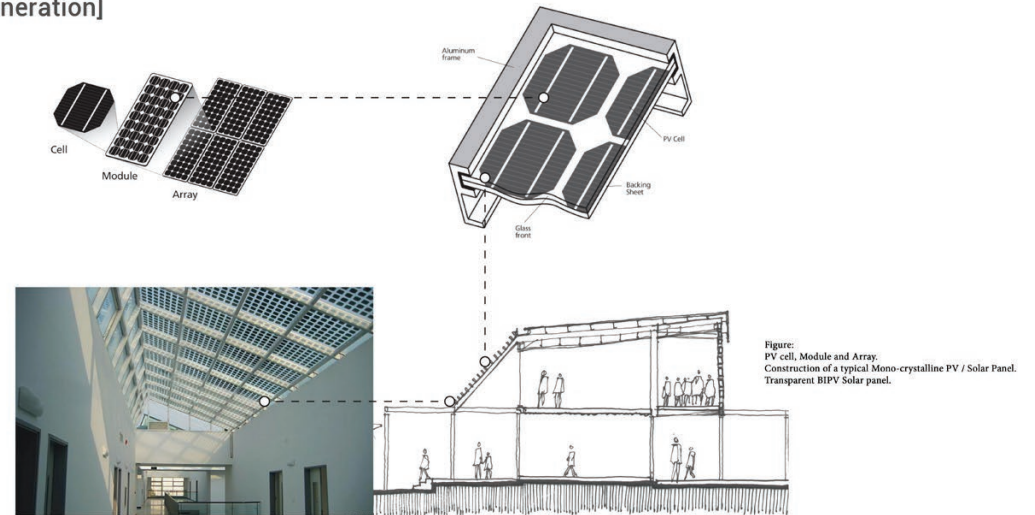

Figure 133: Reimagining the solar panel (Adapted by Author 2016).

[Water + Heating and Cooling]

With the large surfaces from the roofs, 500 square meters and the platforms, water will be collected and stored underneath the platform. This water will be used as grey water for the ablutions as well as for irrigation. The platform performs another function. Geothermal pipes are routed under the platform and are used to heat and cool the building.

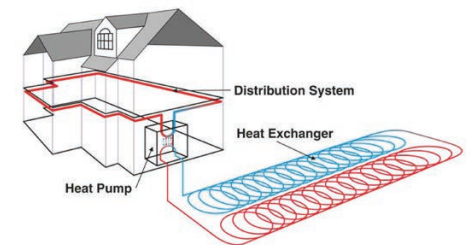
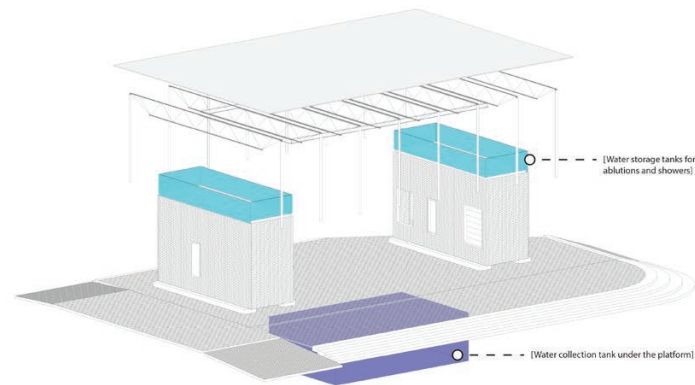

Figure: Ground-source heat pumps require three elements: heat exchanger, heat pump and distribution system.

Figure 134: Water cooling + heating and cooling strategy (Adapted by Author 2016).

Technical precedent

Stack ventilation uses the difference in air temperature to move air. It works from the principle that hot air rises because of its lower pressure. As it rises, it sucks in colder air, bring fresh air into the room (Sustainabilityworkshop.autodesk.com n.d.). The stack effect used in conjunction with a solar chimney which uses the sun as energy source to heat up the air in the

chimney which is then exhausted out of the chimney thereby sucking in cold air at the bottom. This strategy is similar to the one used in the Eastgate Building in Harare, designed by Mick Pearce. It uses solar chimney that ventilate the office spaces and the atria (Doan 2012).

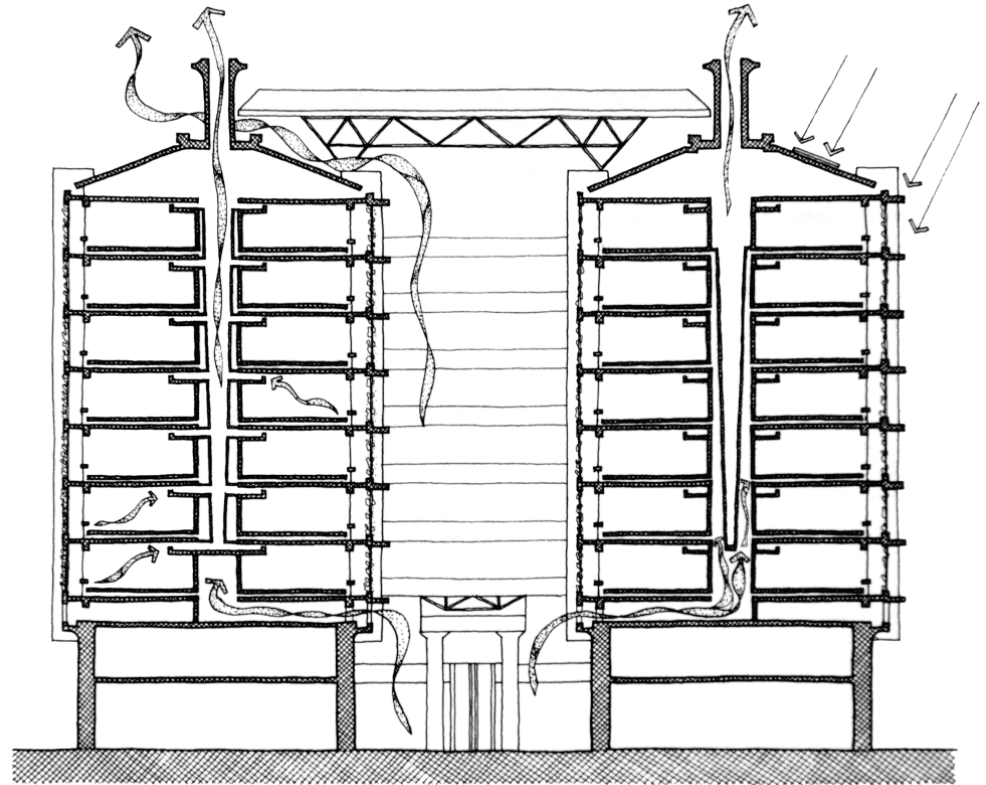

Figure 135:Section of the Eastgate building illustrating the movement of air through the building due to the passive ventilation strategy used (Sustainabilityworkshop.autodesk.com n.d.)

[Ventilation]

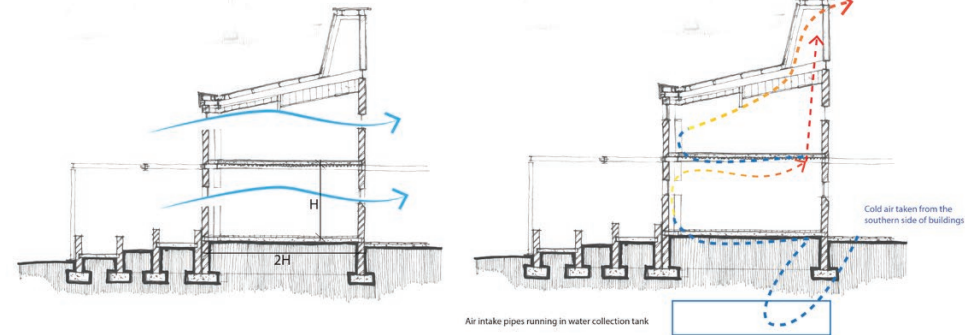

Figure 136: Illustration of ventilation strategies used in the building (Author 2016).

Natural ventilation is possible in all building on the site as the buildings proportions are within the prescribed limit of $h / 2h$, with 'h' being the height from floor to ceiling, will allow for natural wind to exhaust the building of hot air. Alternatively, the water collected under will also be used to drive the passive ventilation system. Cool air will be pulled from the southern side of each building. The pipe that collect the air will be

routed inside the water collection tanks to help further cool the air in the pipes. The air is then injected in the buildings, on all levels, and is the exhausted through the service core of each building.

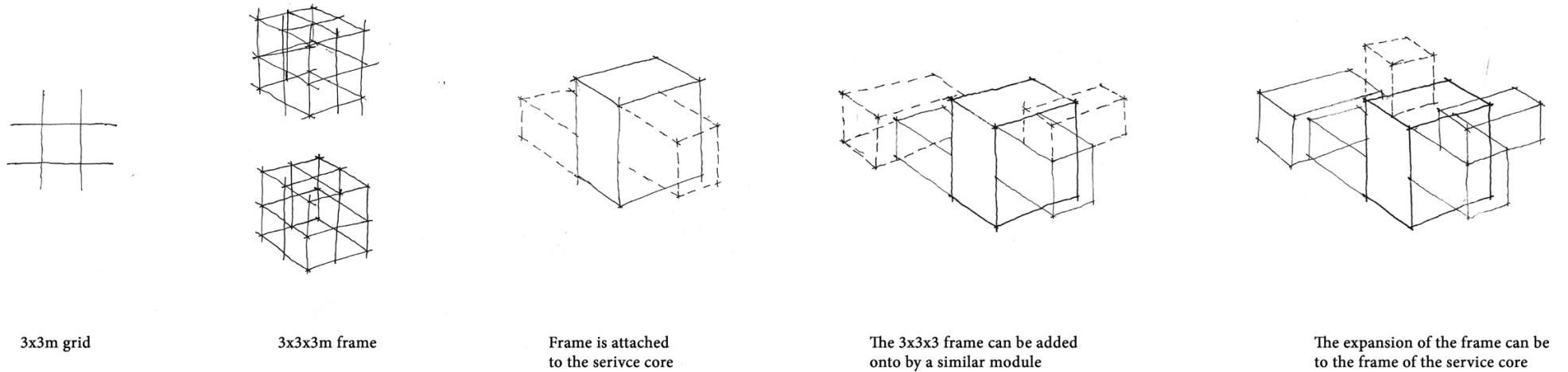

Figure 137: The formation of the grid and how changes can be implemented through it (Author 2016).

8.6 THE STRUCTURE

The grid becomes a three dimensional element which organises and structures the different parts of the building. The grid becomes the primary structure on which the buildings are based upon as shown in figure 122. The modular 3x3 grid is the made into a 3x3x3 frame the buildings are based on. The modular frame will allow for the ability to adapt the

building in the future when the spatial requirements change. The grid could become a universal principle that is used for various building typologies and in this case, it could be used for both the civic proposal of the project and the residential component (small network hubs).

[The GRID]

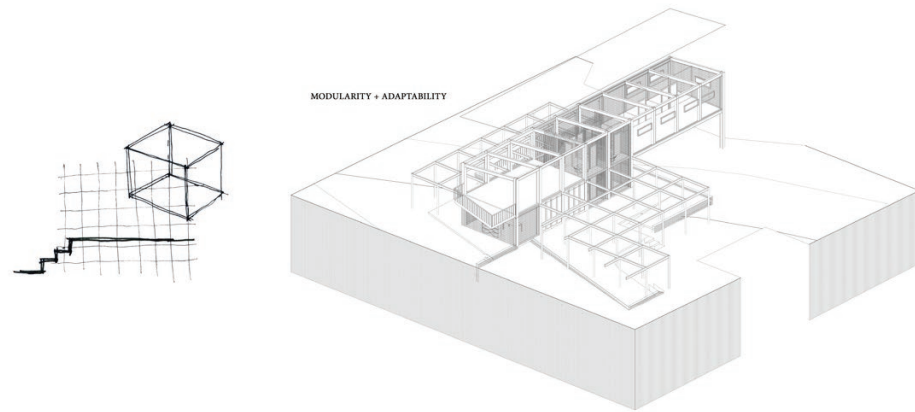

Figure 138: The grid and how it is used to create a building and a link to the landscape (Author 2016).

When one unpacks the architectural technology of the shack, two elements are used:

- A frame
- Cladding

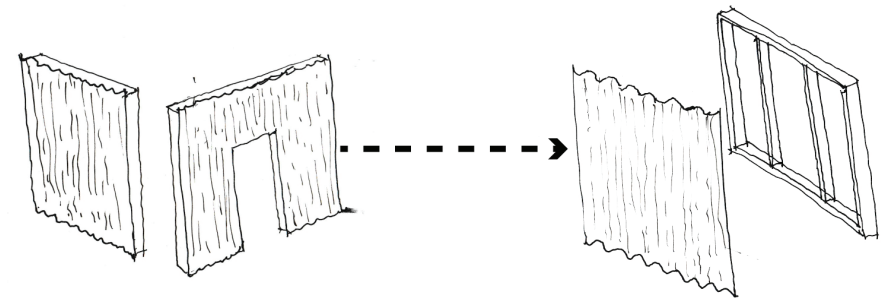
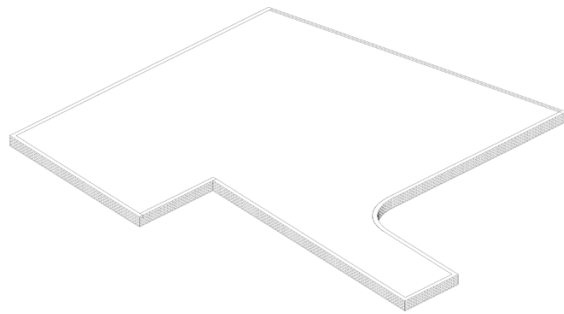

Figure 139: Exploded view of a shack panel. The shack panel elements are reinterpreted to create a new architectural language (Author 2016).

These elements are reinterpreted as:

- The grid
- The panel.

These are elements used to construct the architecture. They reuse familiar building elements in a way that uplifts the existing architectural language in the context.



The platform (podium) that is the base of the building as well as the initial definer of the public space.

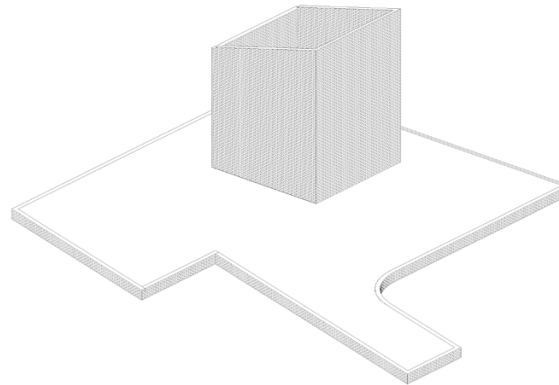

The service core is then built on the platform. These two elements are stereotomic and are built with masonry and form part of the buildings primary structure

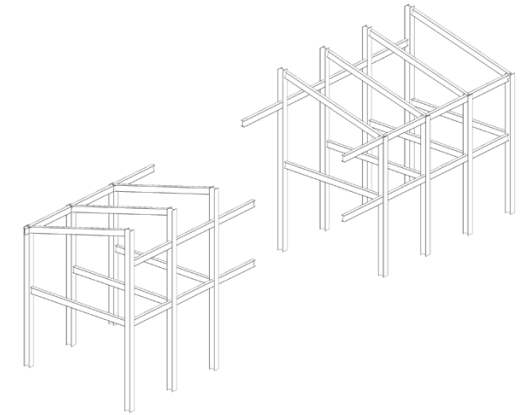

The 3x3 meter grid becomes the basis for the buildings secondary structure

Figure 140: The construction and adaptation of the building (Author 2016).

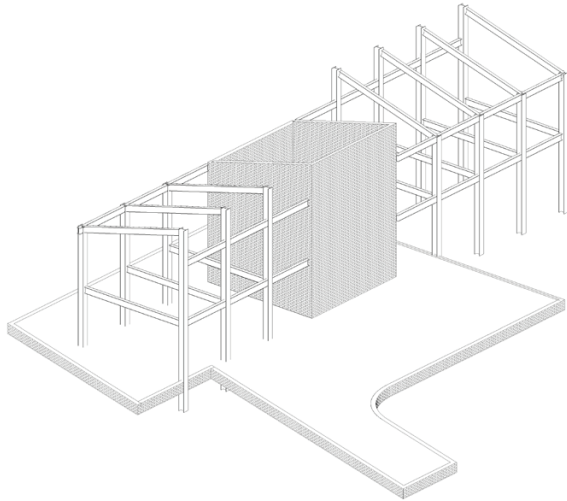

The steel frame are then attached to the platform and the service core, linking the primary and secondary structural elements.

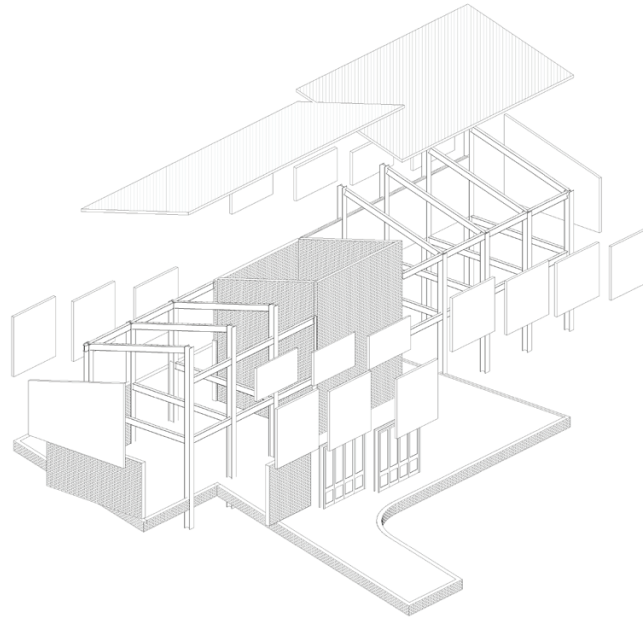

Prefabricated wall, roof and floor panels will then infill the steel frame. The type of panel will depend on the orientation of the wall panel and the internal function / activity that is enclosing.

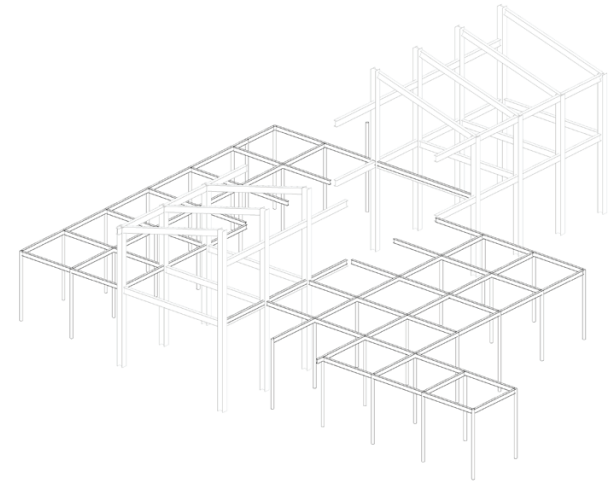

The steel frame can be adapted with a frame using the same 3x3 metre grid. The grid becomes the element that will link the landscape and building.

8.7 THE PANEL

The panel becomes an integral element. It becomes the infill of grid and an element that adds to the architectural language of the building. The panel is a familiar architectural element that is then reinterpreted and given more meaning. The panel will take different forms depending in the function of the space inside, its orientation to the sun and the level of privacy needed. The panel can be a static element; as a wall / roof panel or a dynamic element such as a door or a movable interior panel.

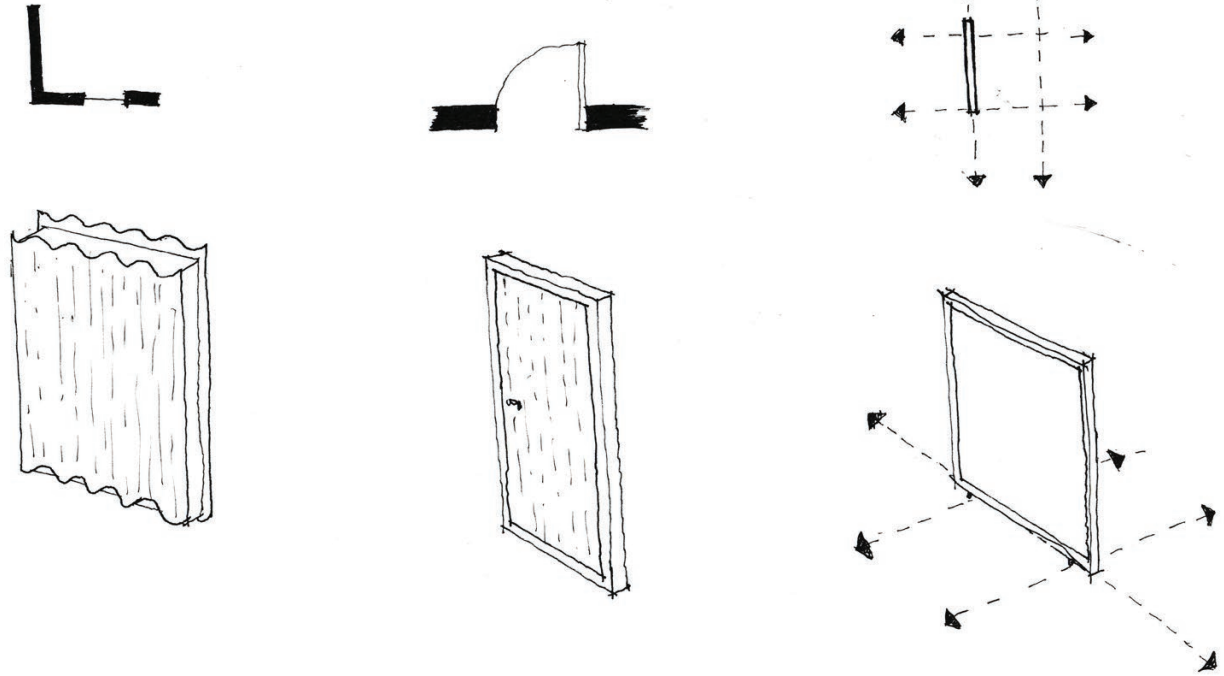
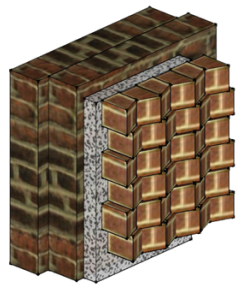
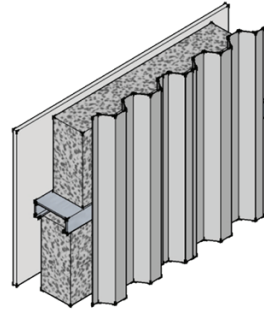

Figure 141: The panel in the various forms. (Author 2016)

[The PANEL]



[Brick infill]
East and west orientated walls
Service cores



[Light gauge steel]
North orientated walls
Service rooms
Office spaces

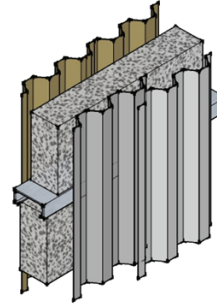

[Light gauge steel]
North / South orientated walls
Office spaces

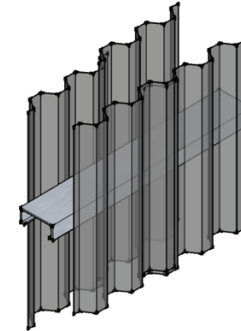

[Light gauge steel]
South orientated walls
Circulation spaces

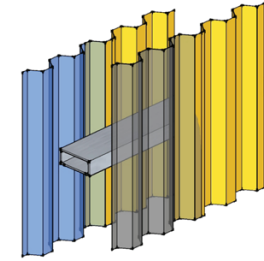

[Aluminium]
Sliding door panels

Figure 142: Variations of the panel (Author 2016).

The panel will be a locally manufactured item. The panel structure will have two structures:

- SA pine structure
- Light gauge steel

The choice between the two depends on the structural needs and the financial constraints. Having a structure that is cheaper to produce allows for smaller projects to use the similar design principles and technology. This project will

use light gauge steel as the primary structure of the panel. This is to illustrate the option of this being a feasible building technology in this context. This may result in a new business venture that may be created.

Standard panel size fitting a 3x3 meter grid frame will be made off site and additional panels that can not fit the standard grid will be made on site. The panels will be created off site and then brought to site for installation. This creates a possible production network within Mamelodi, from raw material to final product. Petrus Wolmarans' dissertation on TVET colleges and their guilds will produce the panels.

THE PANEL - Infill panels which become the initial phase of the building.

8.7.1 The wall panel.

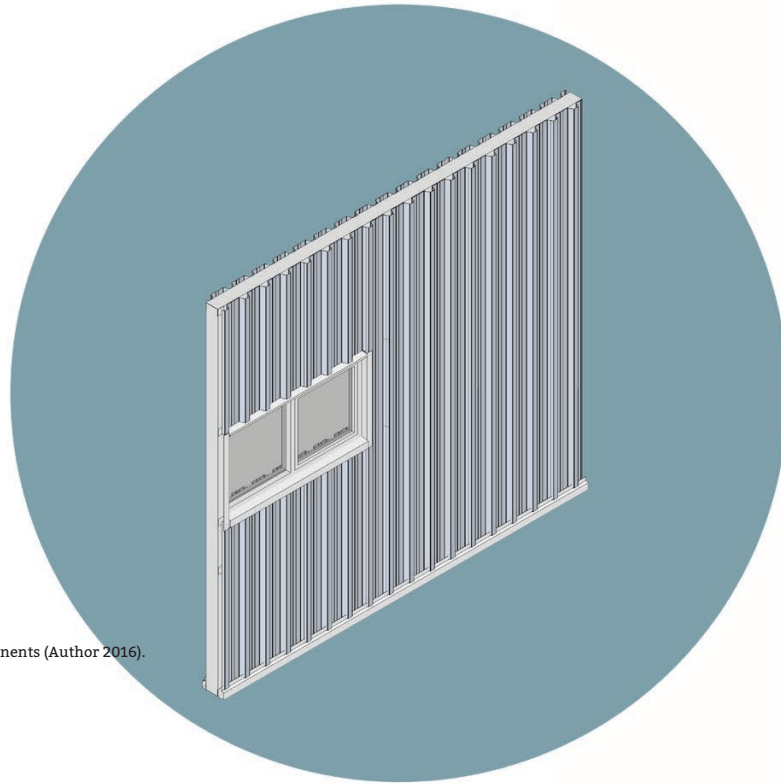
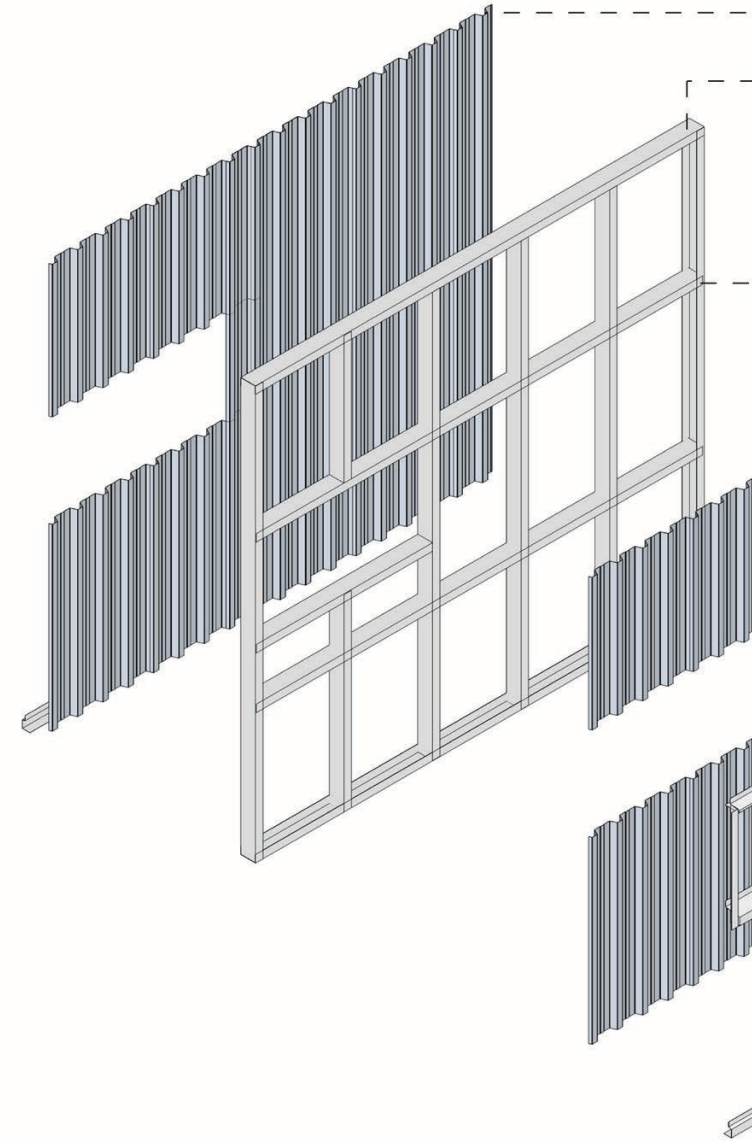

Figure 143: Basic corrugated steel wall panel and its components (Author 2016).



The Panel

The panels are designed to be a prefabricated panel system that is inserted into a frame. The panel system becomes the initial phase for the building. This is then followed by the addition of an attachment system.

0.58mm Chromadek IBR 686 steel sheeting screwed on to Zin-
calum light steel studs at 600mm centres

102mm Zincaluminium steel Top track

102mm Zincaluminium light steel studs placed at 1200mm centres

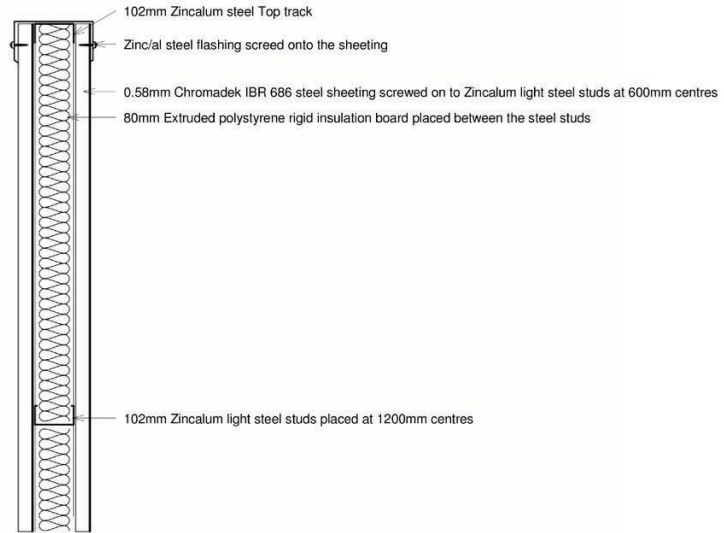
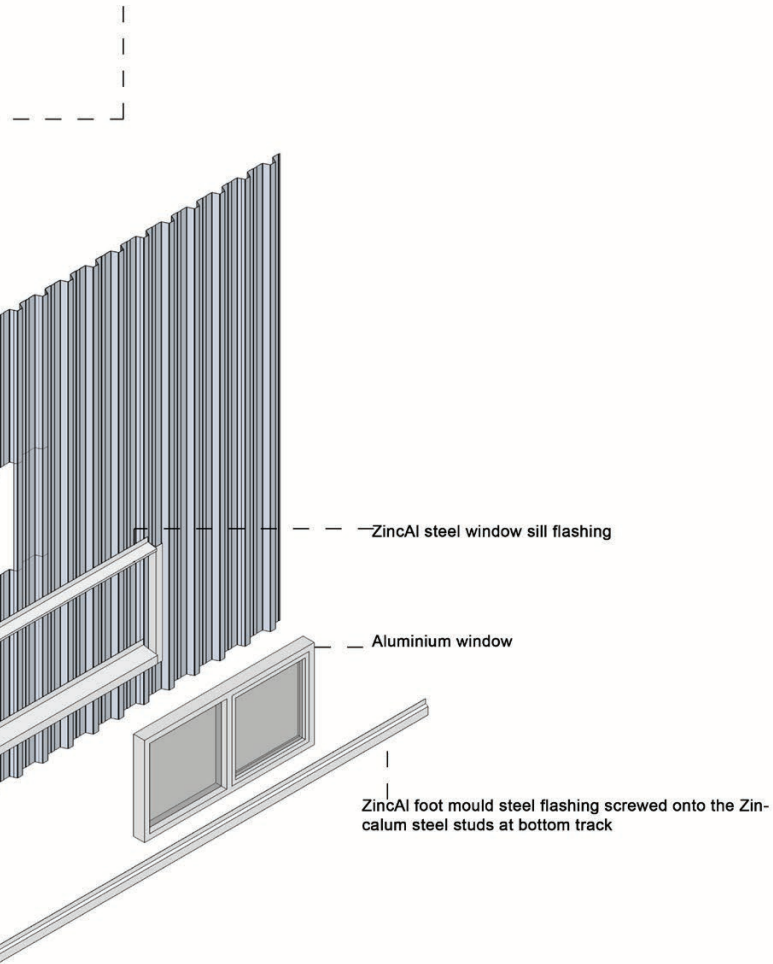

PANEL DETAIL TOP

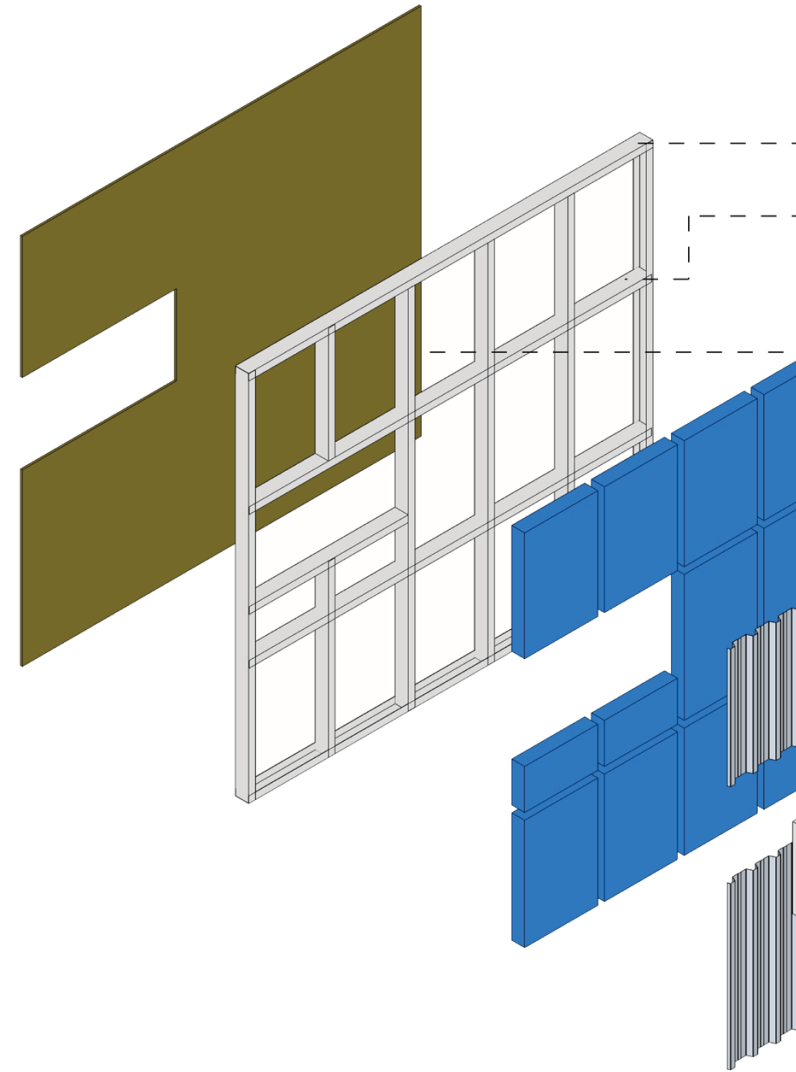
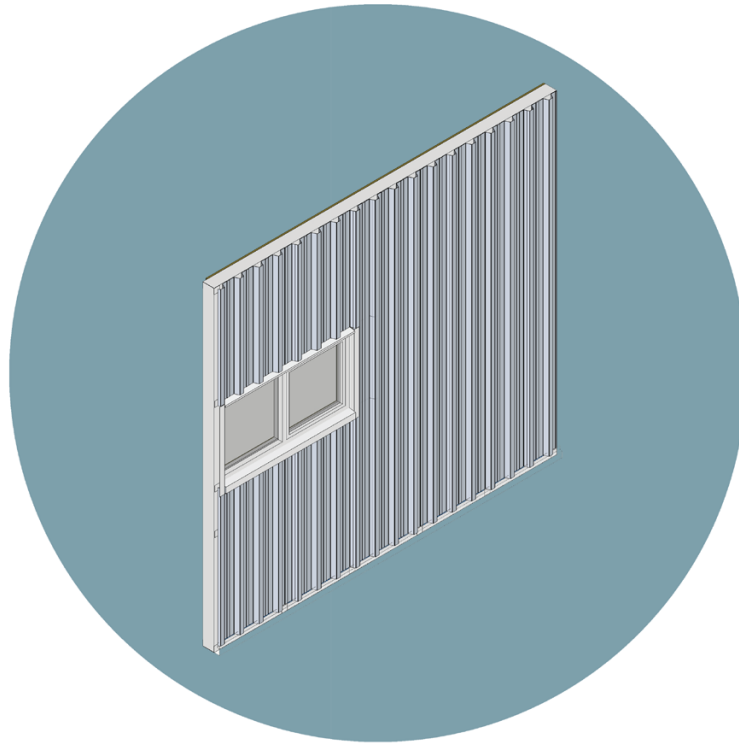
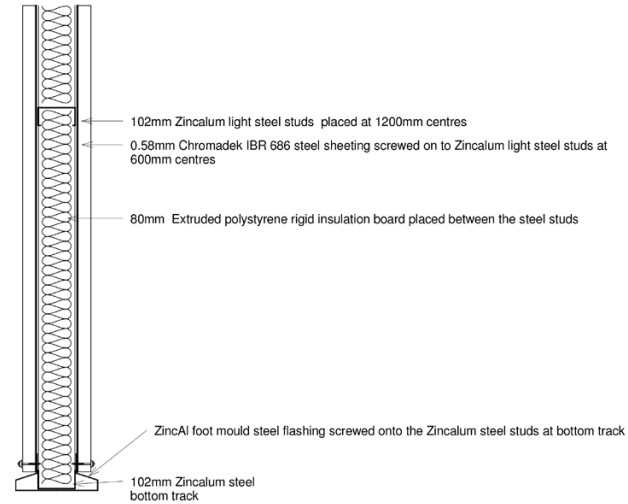
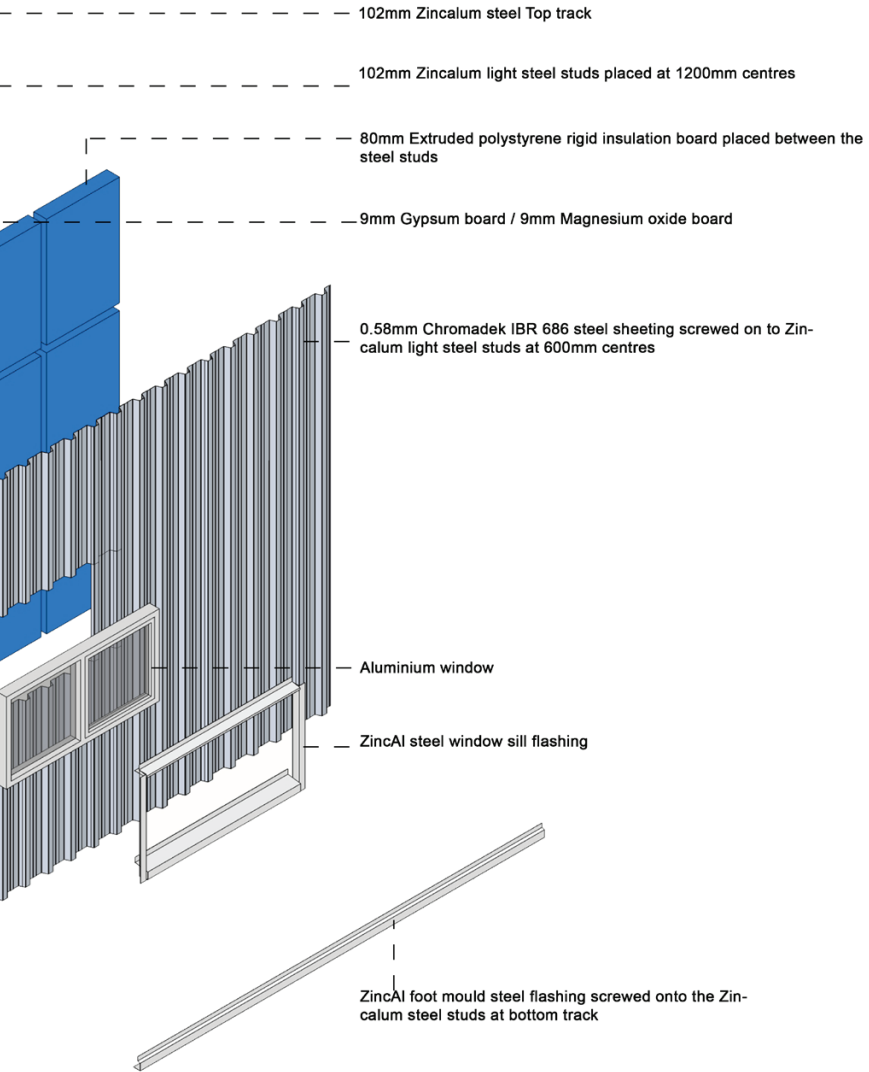

Figure 144: Wall panel. Corrugated steel and magnesium board or gypsum board as an interior finish (Author 2016).



PANEL DETAIL BOTTOM

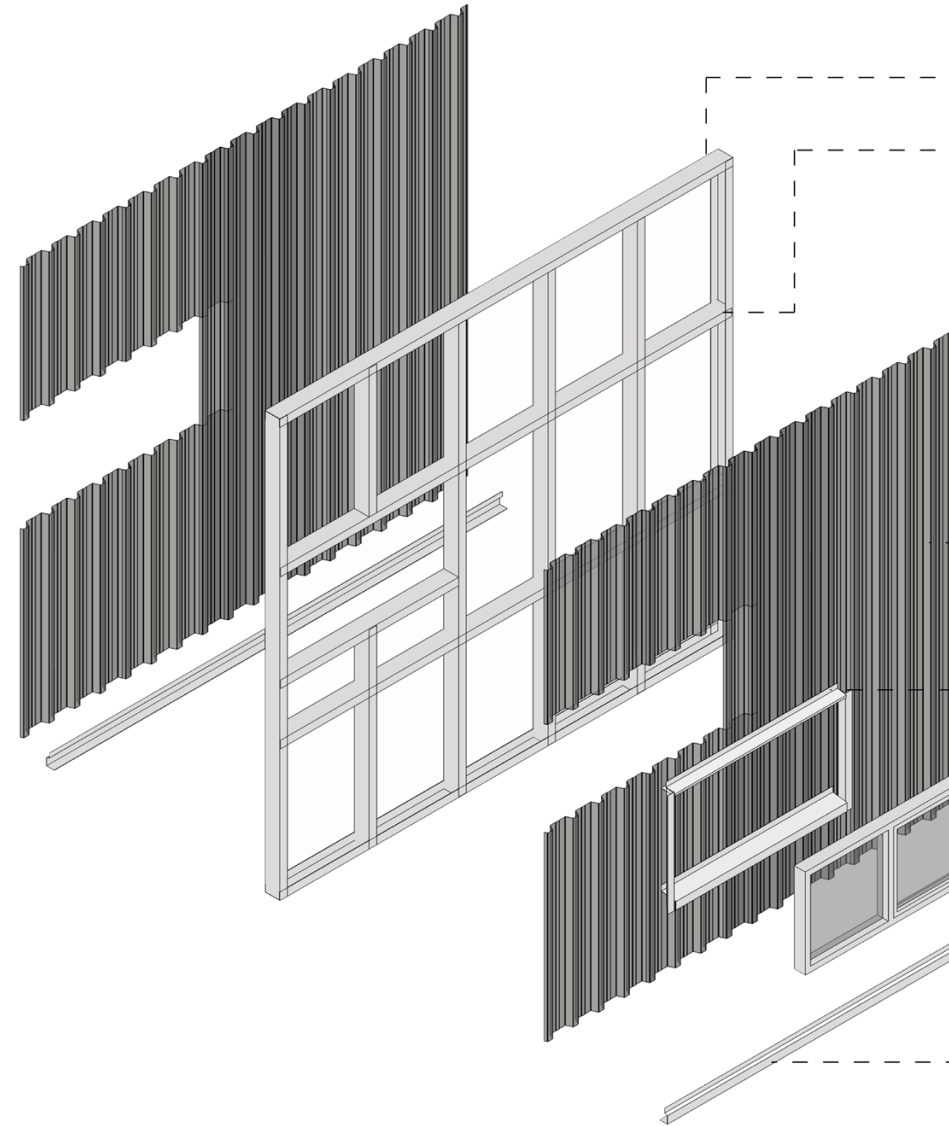
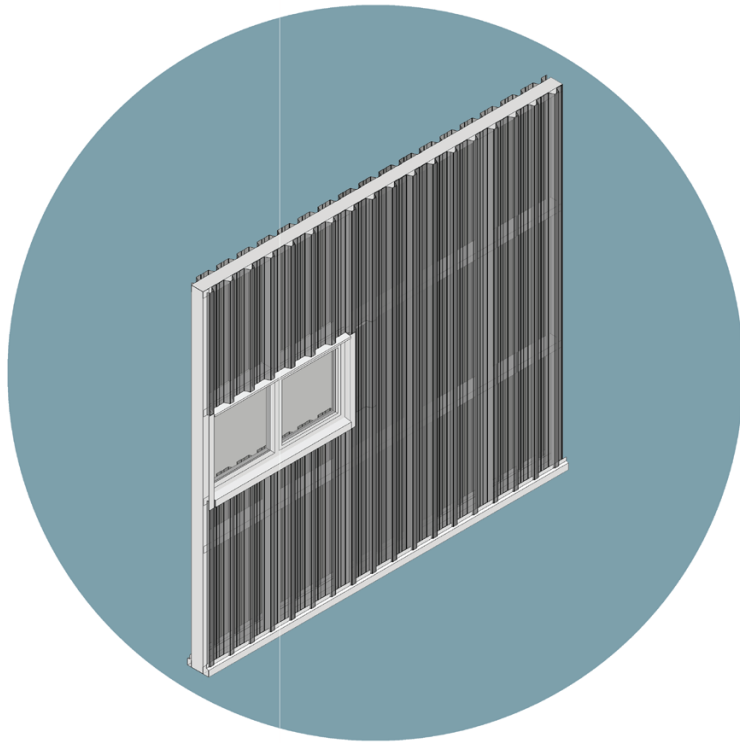
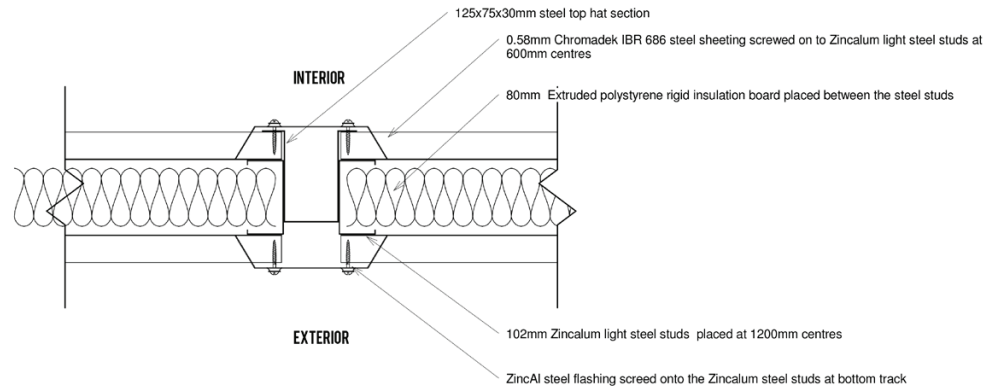
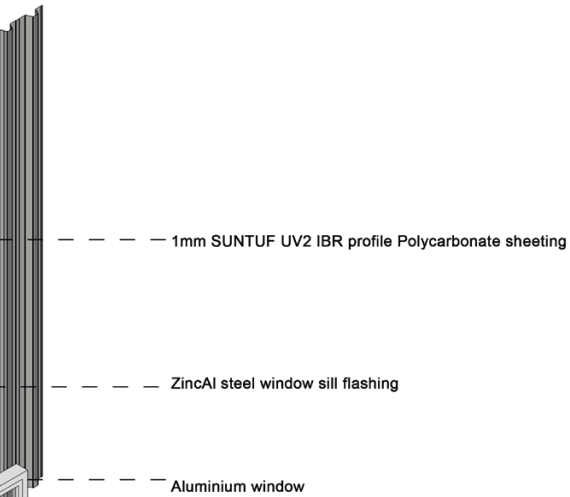

Figure 145: Wall panel. Polycarbonate sheeting with a UV layer placed on both the interior and exterior (Author 2016).

- 102mm Zincaluminium steel Top track
- 102mm Zincaluminium light steel studs placed at 1200mm centres



 **PANEL DETAIL JOINT**

- ZincAl foot mould steel flashing screwed onto the Zincaluminium steel studs at bottom track

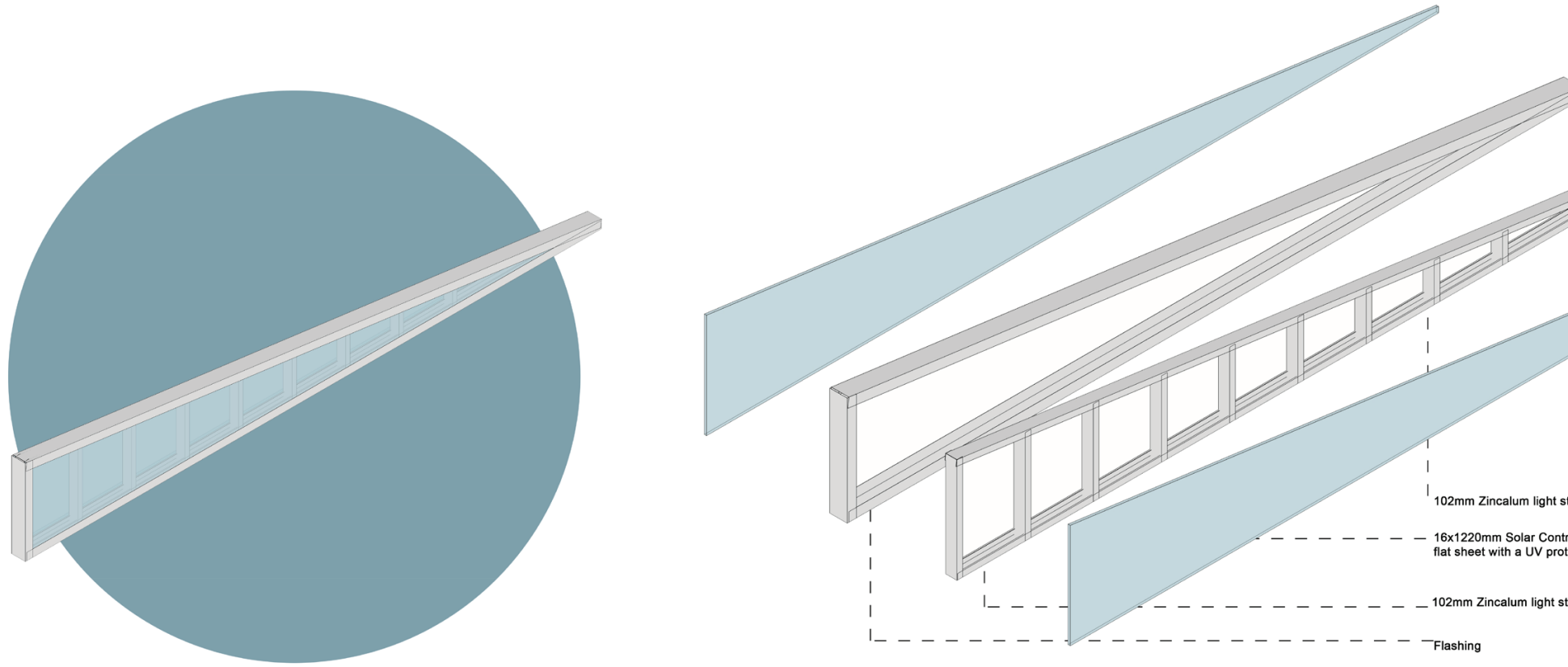
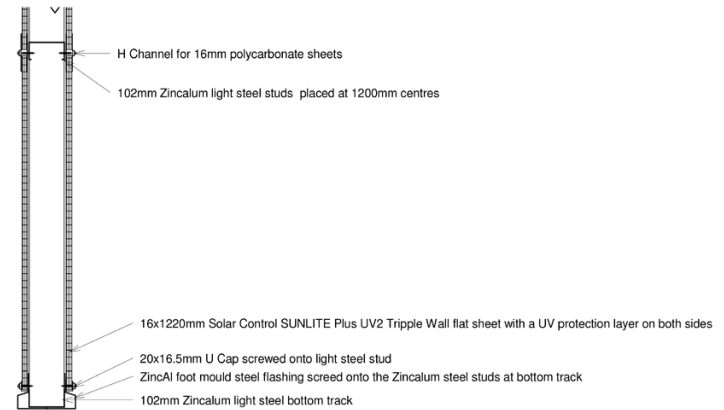
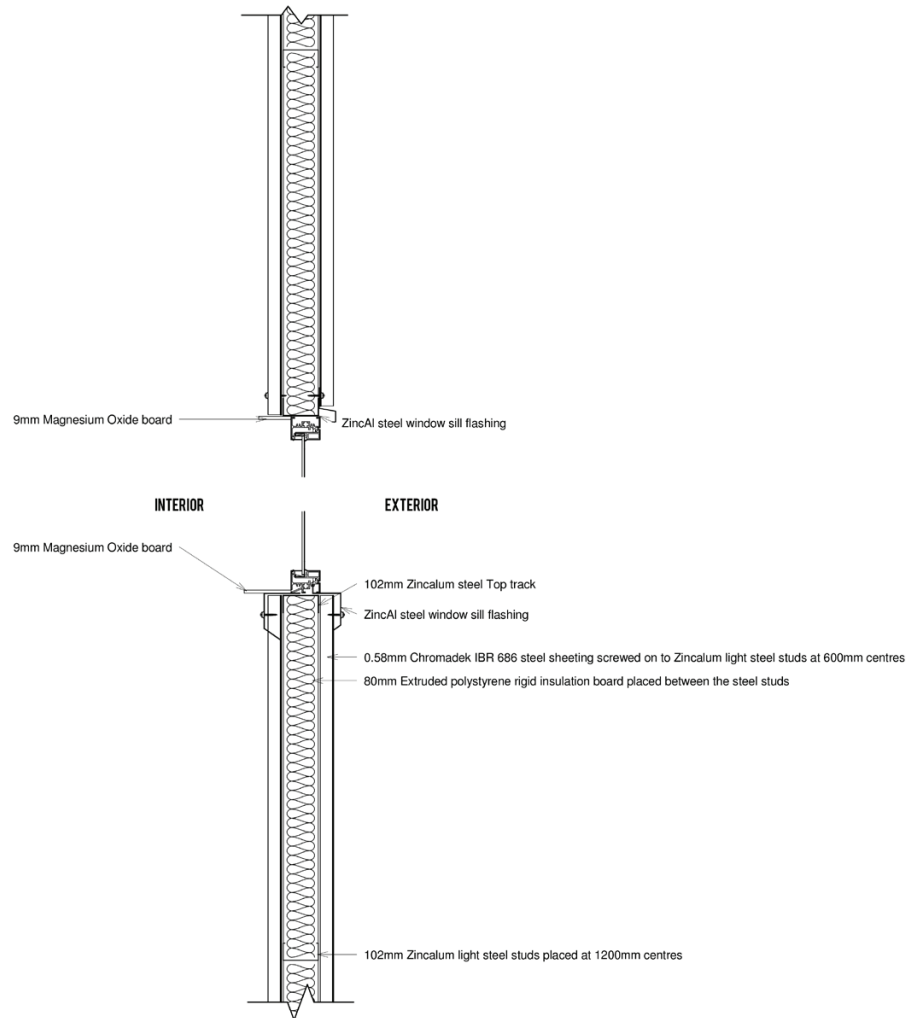

Figure 146: Wall panel. This is a custom wall panel. This item will be used for non-modular infill panels (Author 2016).



WINDOW DETAIL



TRANSLUCENT PANEL BOTTOM DETAIL

8.7.2 The door panel

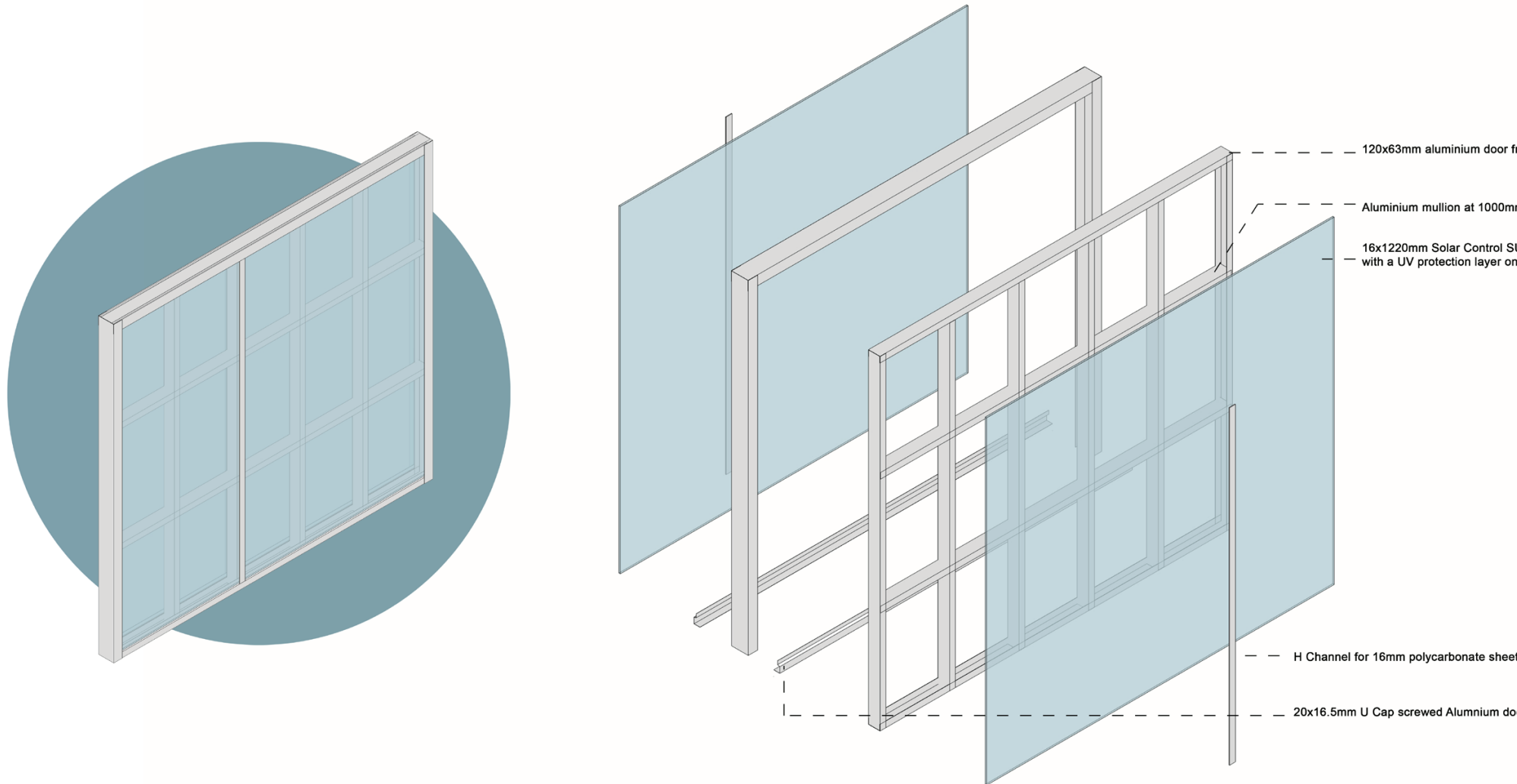
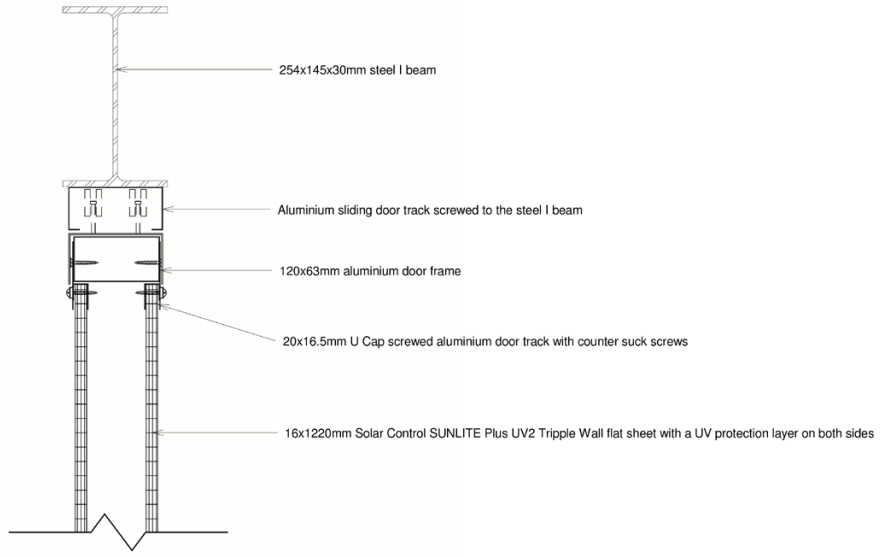

Figure 147: Sliding door panel. This sliding door is used in the administration building and the community hall (Author 2016).

frame

m centres

SUNLITE Plus UV2 Tripple Wall flat sheet
both sides



is screwed to aluminium mullion

or track with counter suck screws



SLIDING DOOR DETAIL TOP RAIL

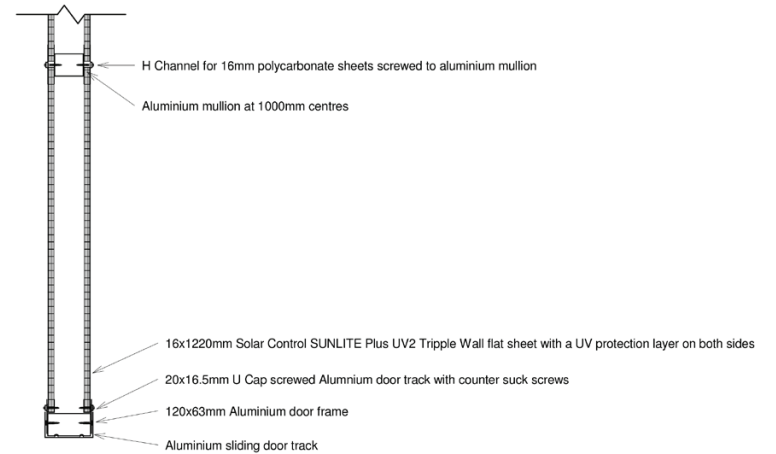

SLIDING DOOR DETAIL

8.7.3 The roof panel

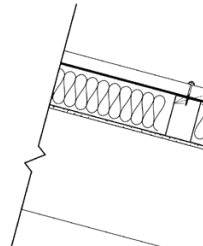
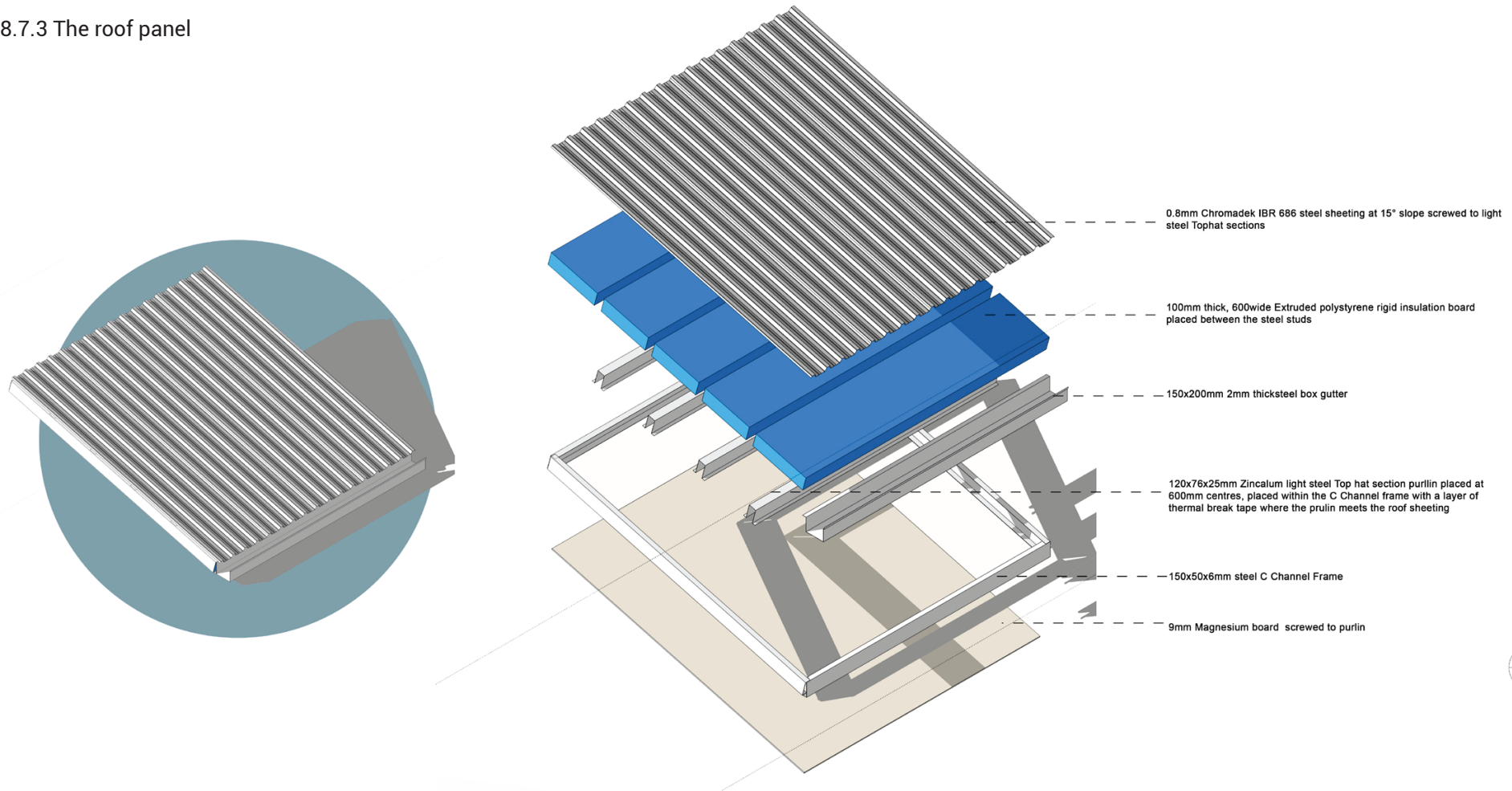

ROOF GUTTER

Figure 148: Roof panel. The panel is a modular element (Author 2016).

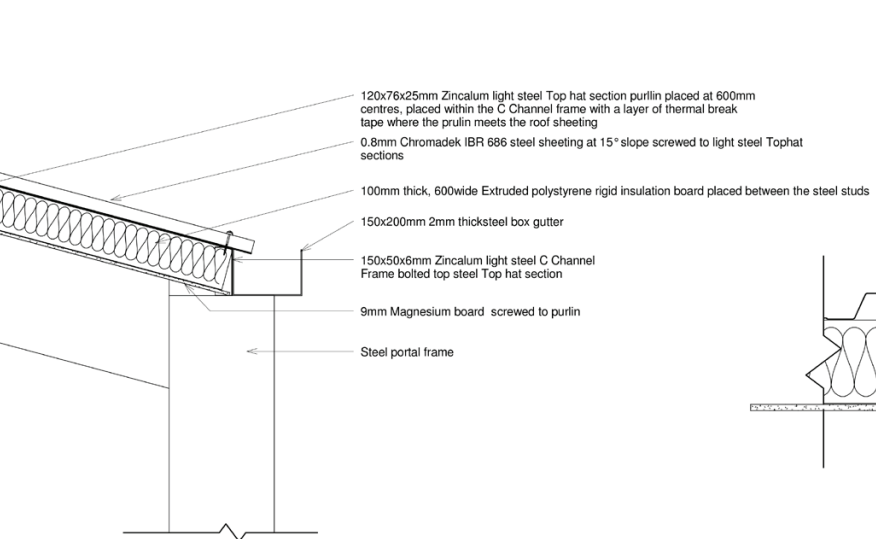

R DETAIL

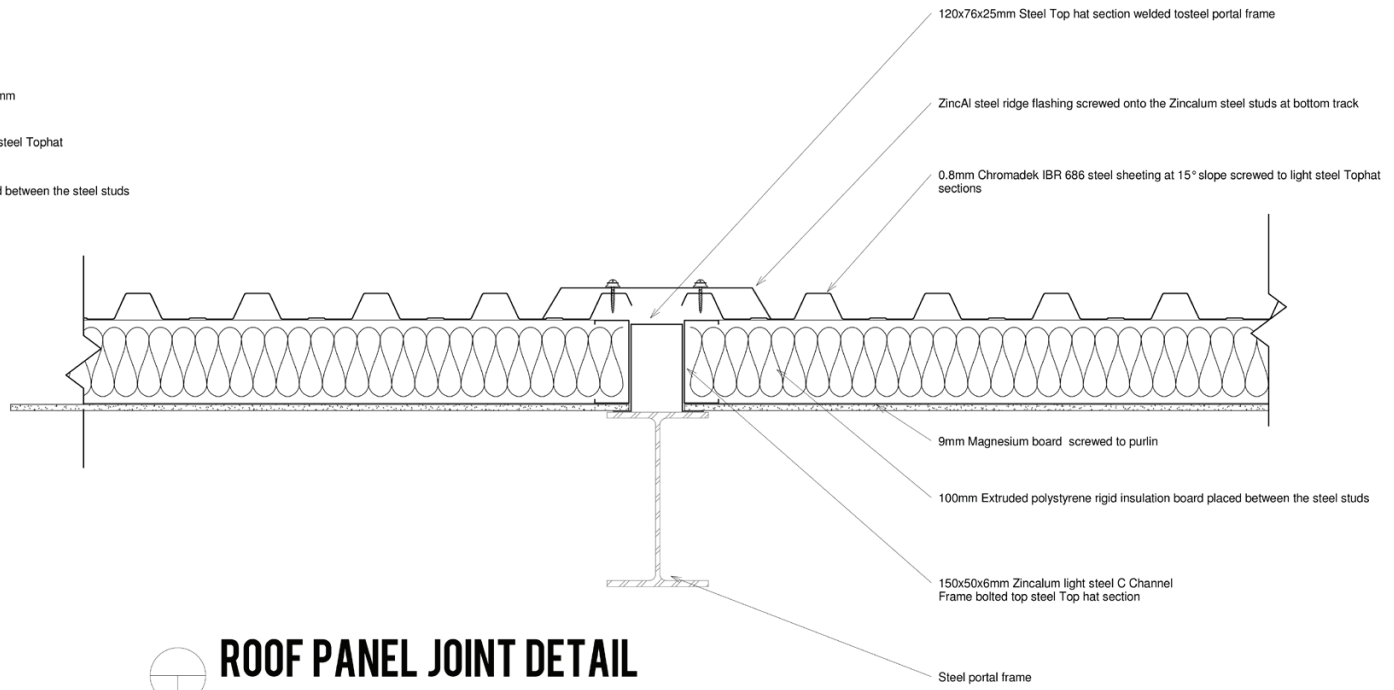

ROOF PANEL JOINT DETAIL

THE PANEL - Attachments to the basic panel. Second phase adapting of the building.

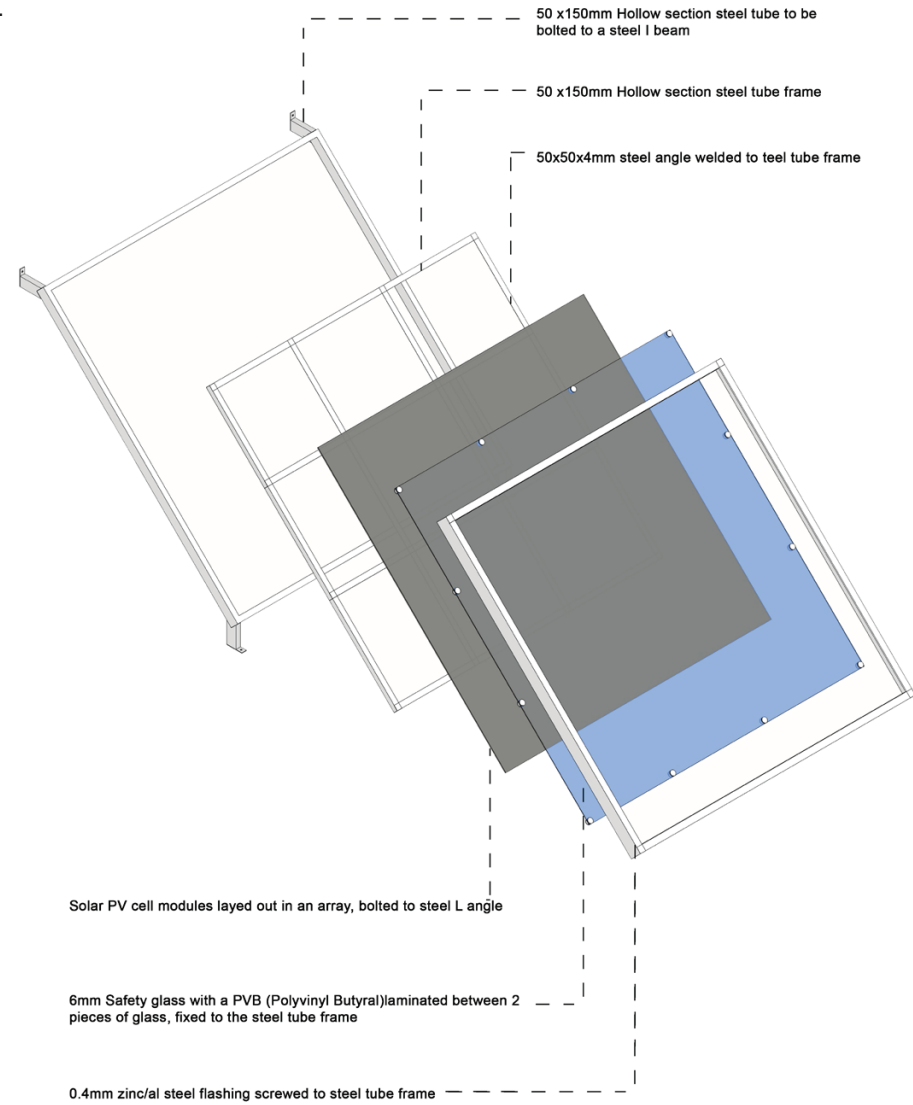
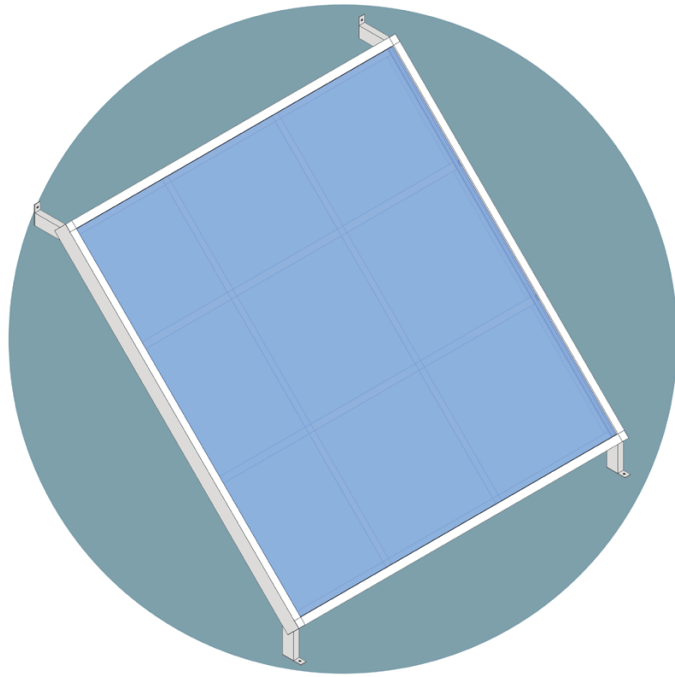

Figure 149: The solar panel. This becomes an attachment to the building and works with the 3x3x3 grid (Author 2016).



8.7.5 Shading attachments

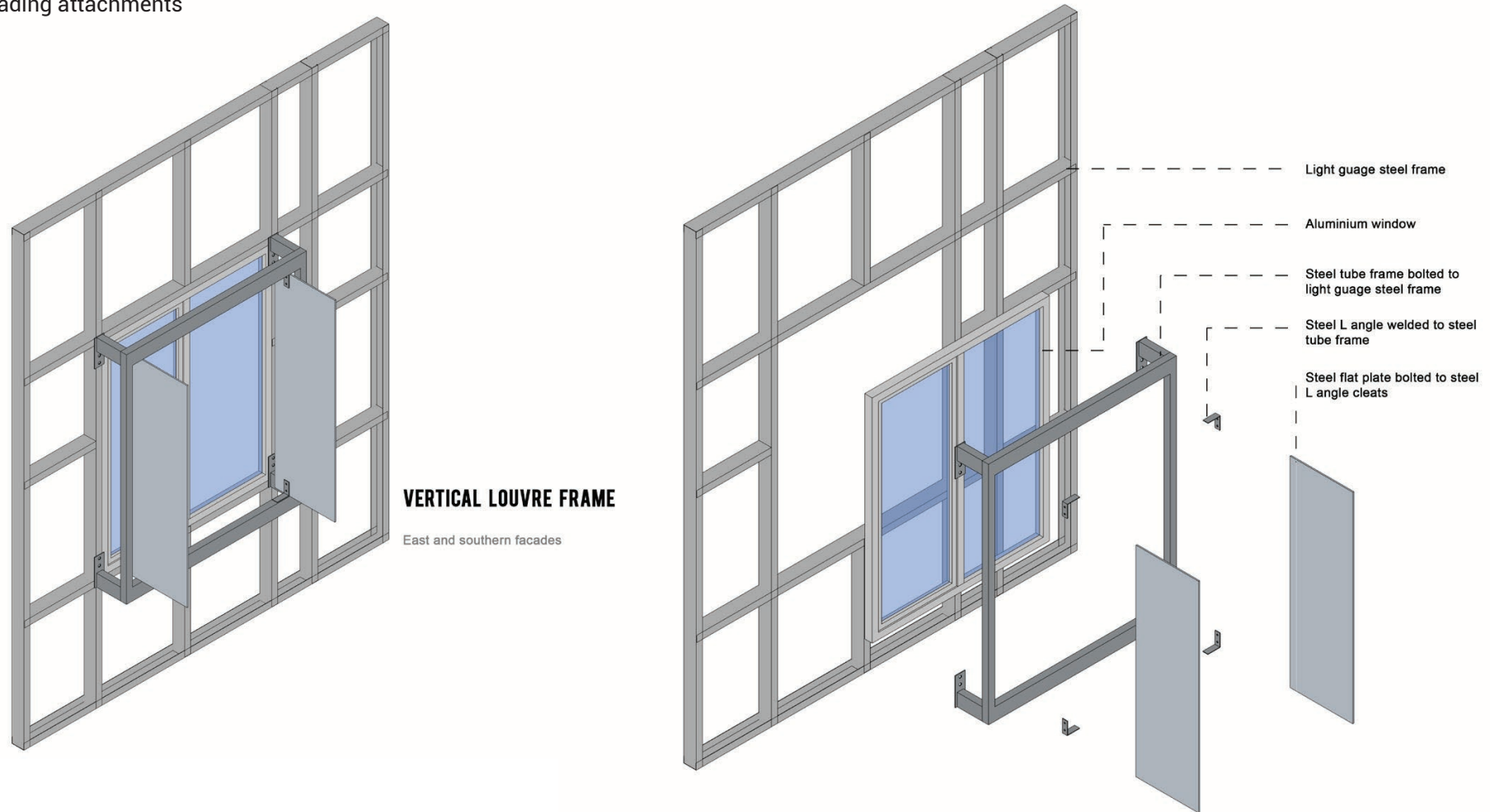
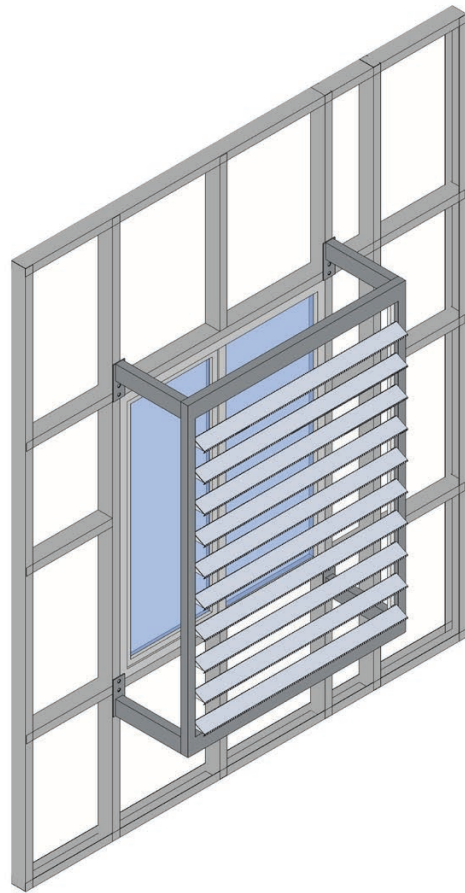
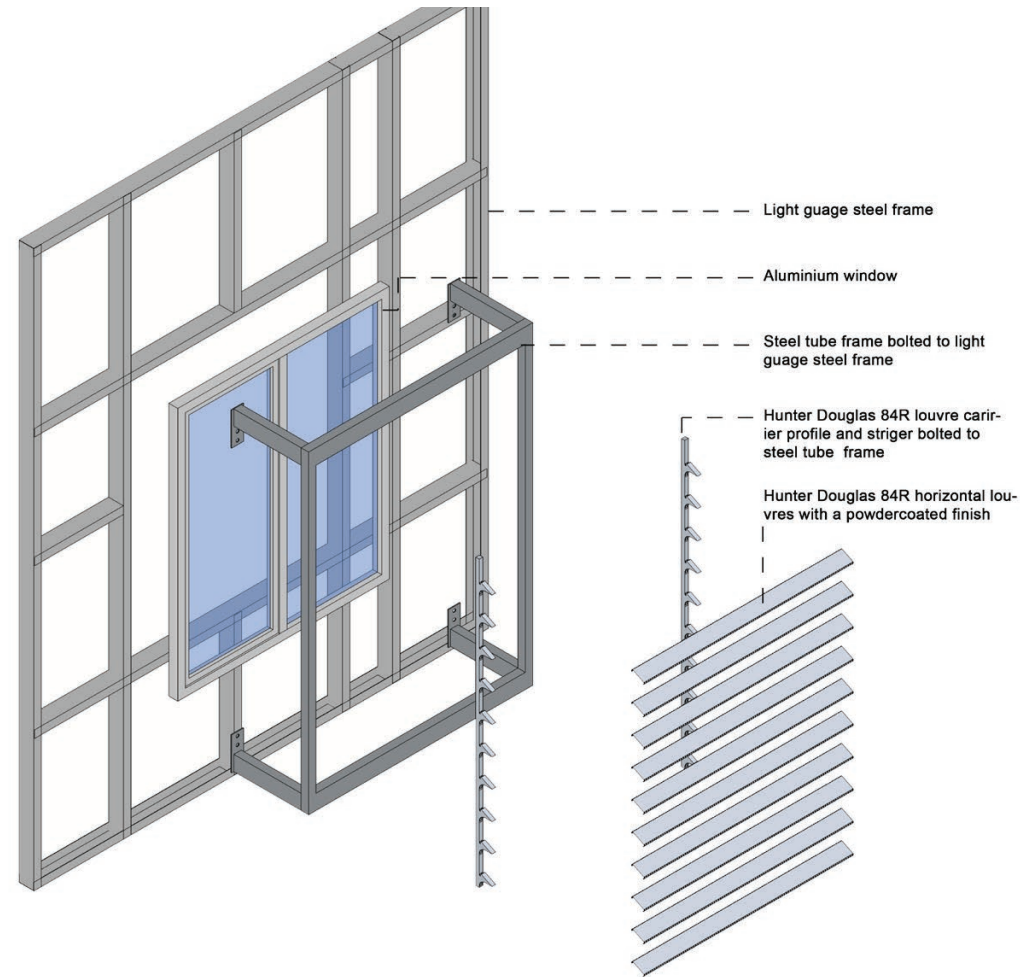

Figure 150: Shading system. The modular system leads to a building with no overhangs over the fenestration. The system allows the building to perform better climatically (Author 2016).



HORIZONTAL LOUVRE FRAME

Northern facades



Attachments

The following attachments form a system that is used to adapt the architecture. They become the second phase of adapting the building. The attachments have various roles to aid the sustainability of the building.

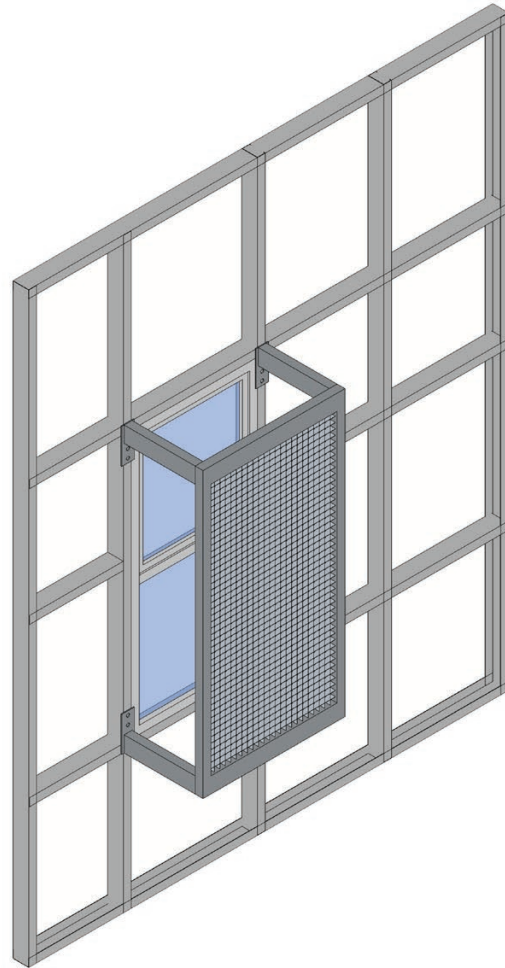

MENTIS LOUVRE FRAME

All facades. Used for privacy

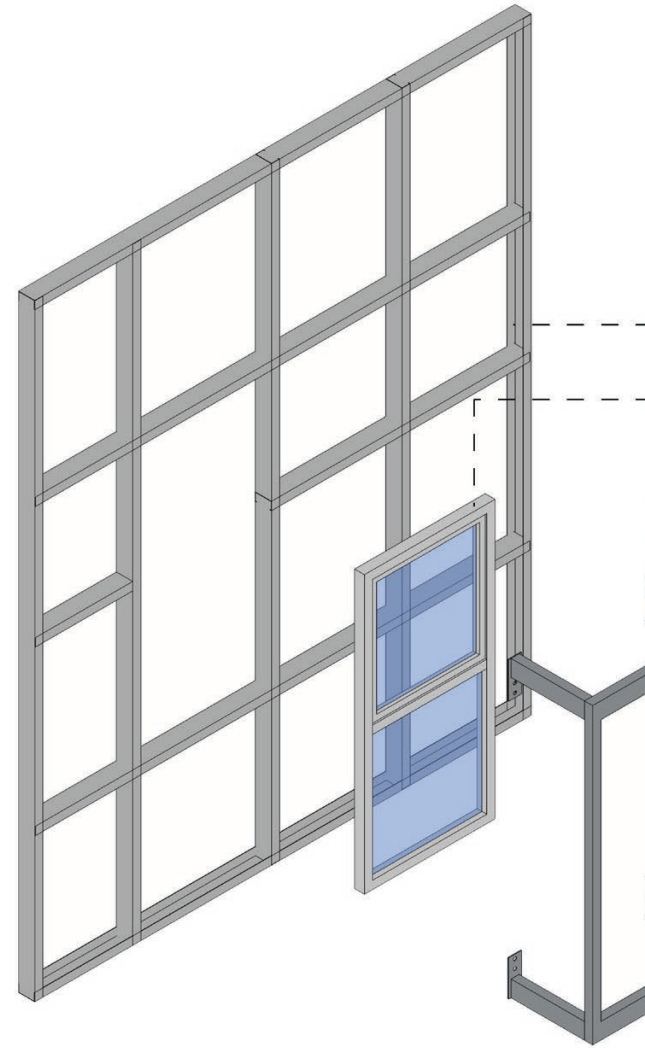
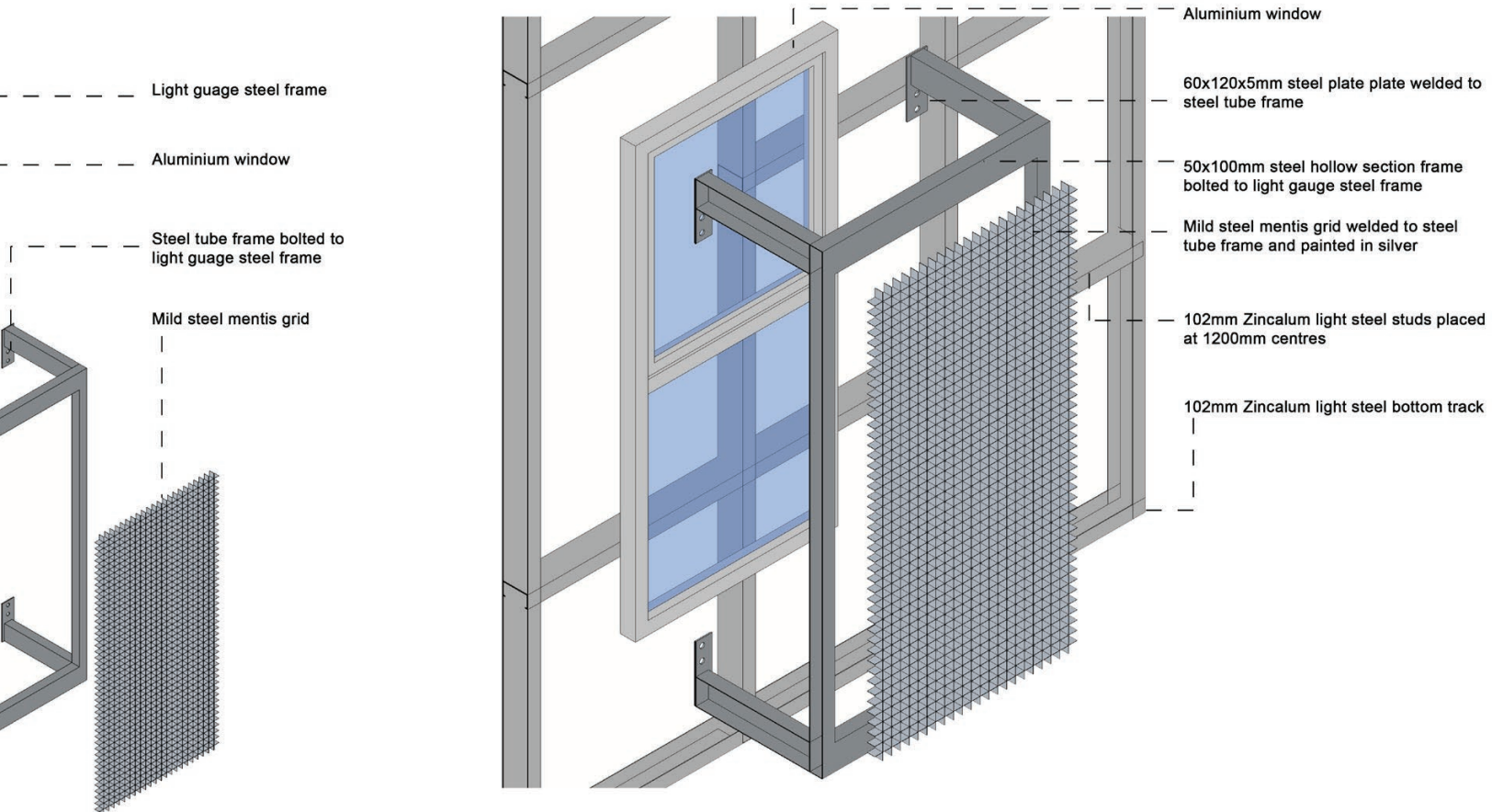

Figure 151: Shading system (Author 2016).



8.7.6 The adapted building

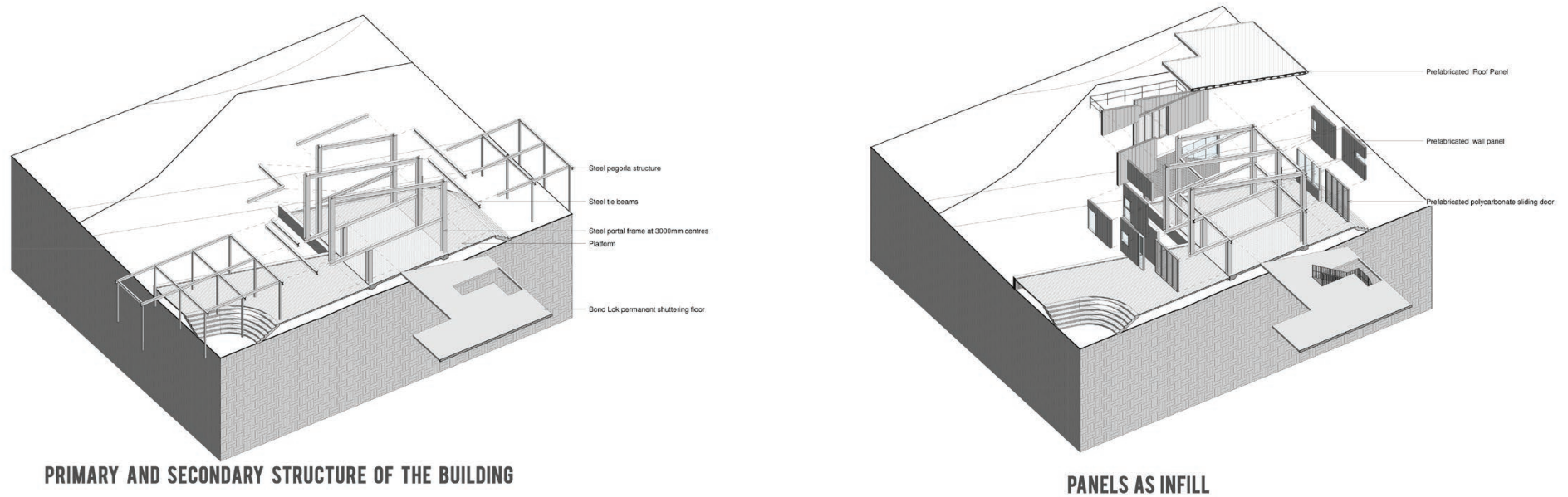
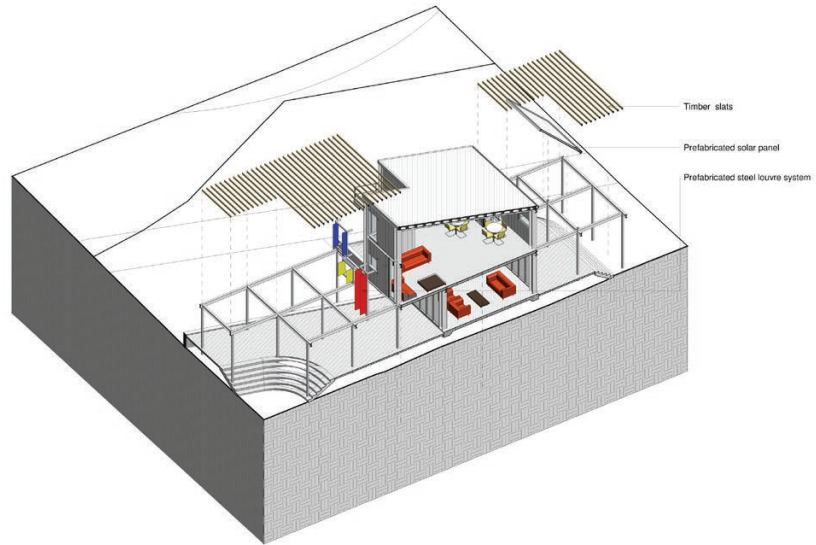
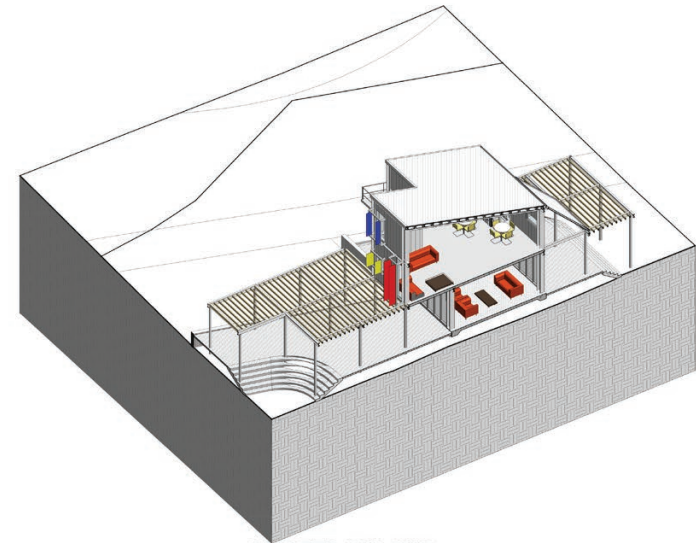

Figure 152: The adapting of the building over time (Author 2016).



ADDING ATTACHEMENTS



ADAPTED BUILDING

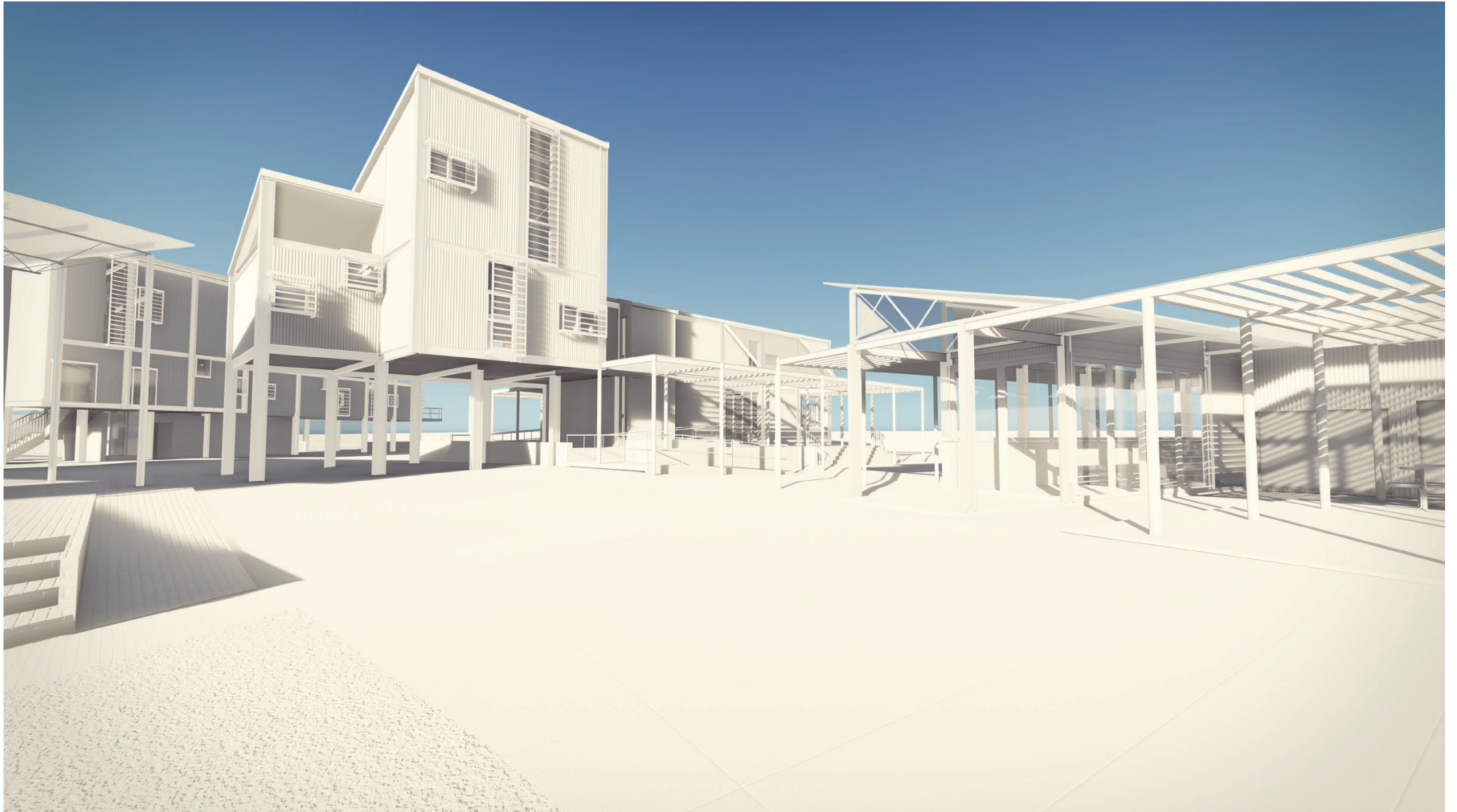
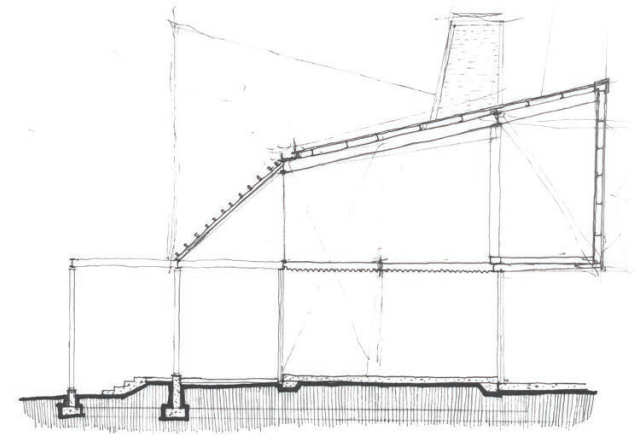
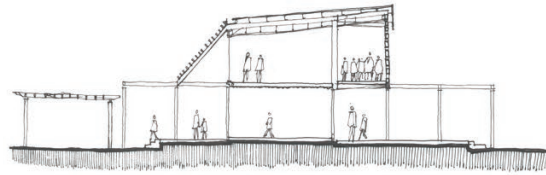

Figure 153:3D rendering of the building in its adapted phase with both panels and attachments (Author 2016).



Figure 154:3D rendering of the building in its adapted phase with both panels and attachments (Author 2016).



Two buildings are detailed to investigate the two different primary structure employed in the design project. The Administration building uses a portal frame structure while the community hall uses a beam and column structure. The connection between the structure and the prefabricated panels are investigated.

Three sections of the administration building are developed to illustrate the possible frame infill depending on the internal function as well as the orientation of the planes.

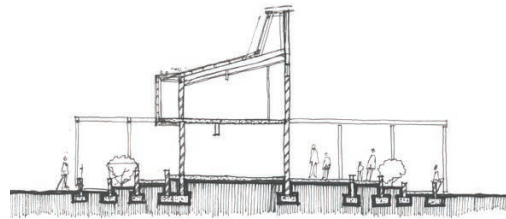
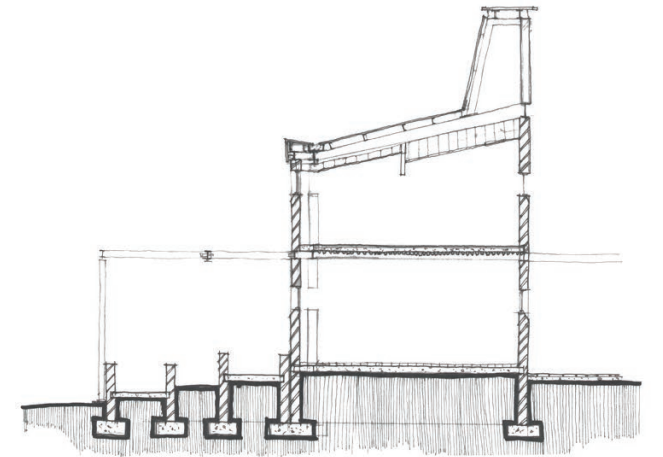

Figure 155: Admin building sections (Author 2016).



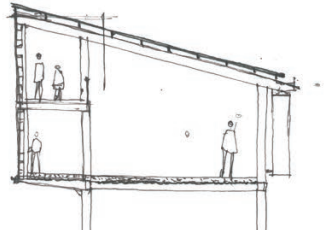
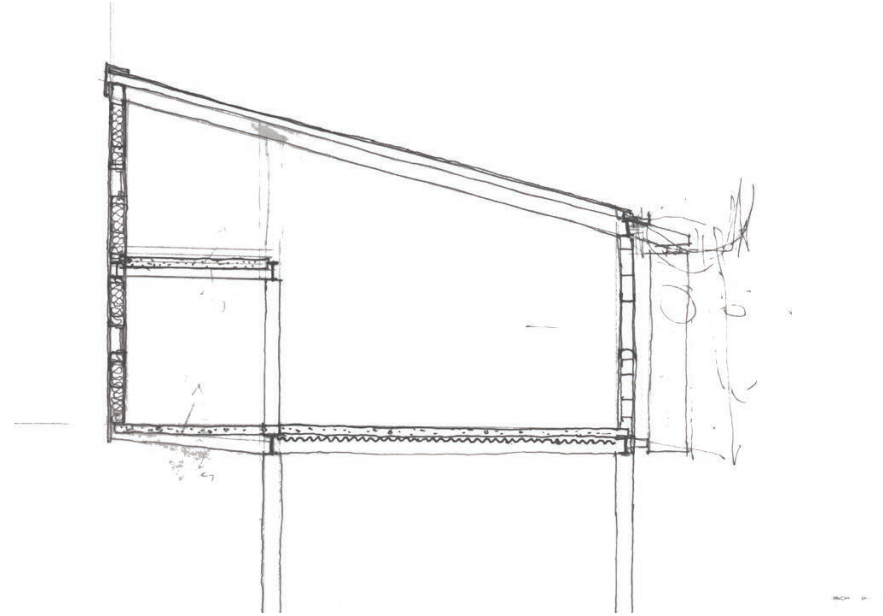

Figure 156: Admin building sections (Author 2016).



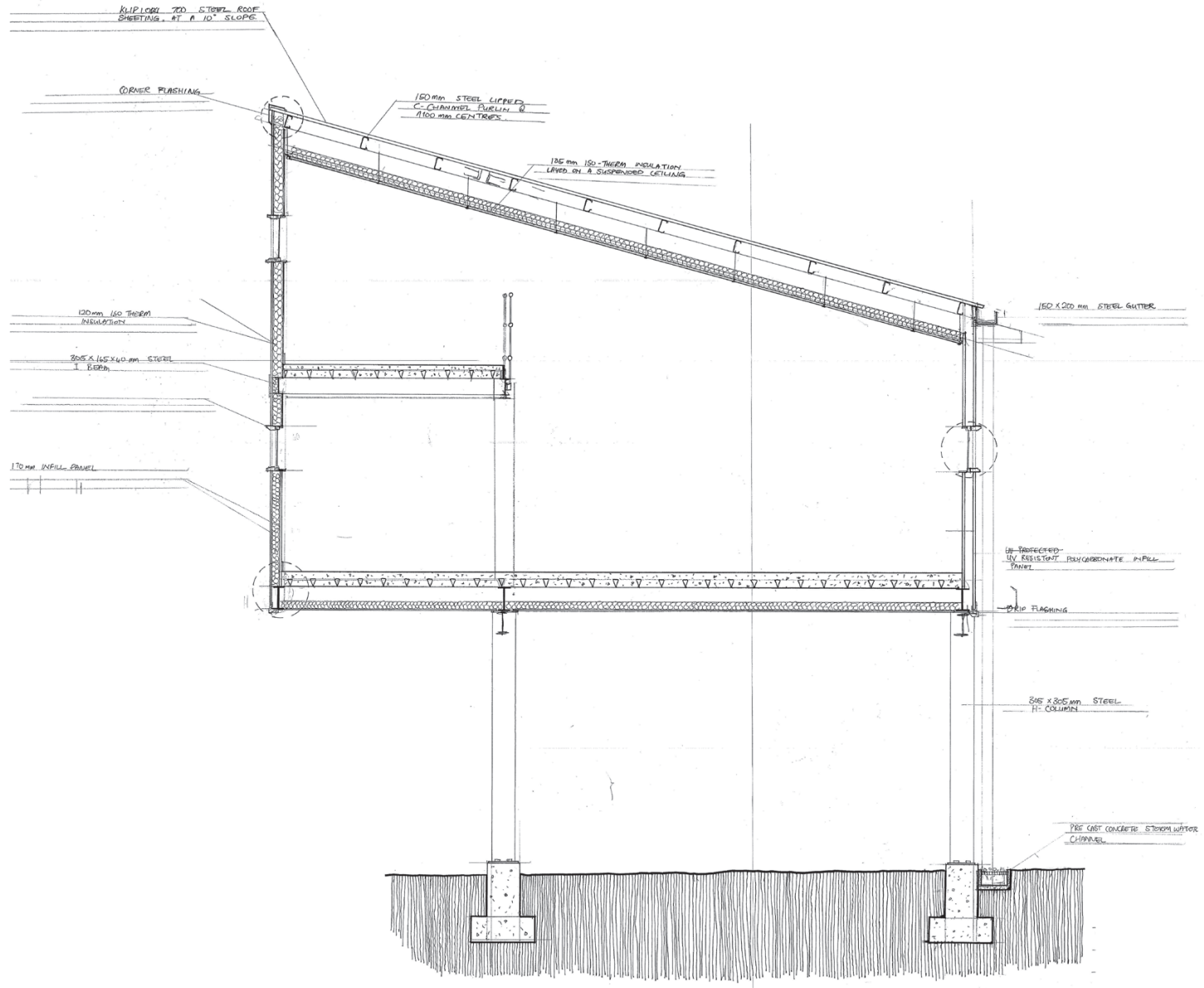

Figure 157: Technical exploration of the administration building N.T.S (Author 2016).

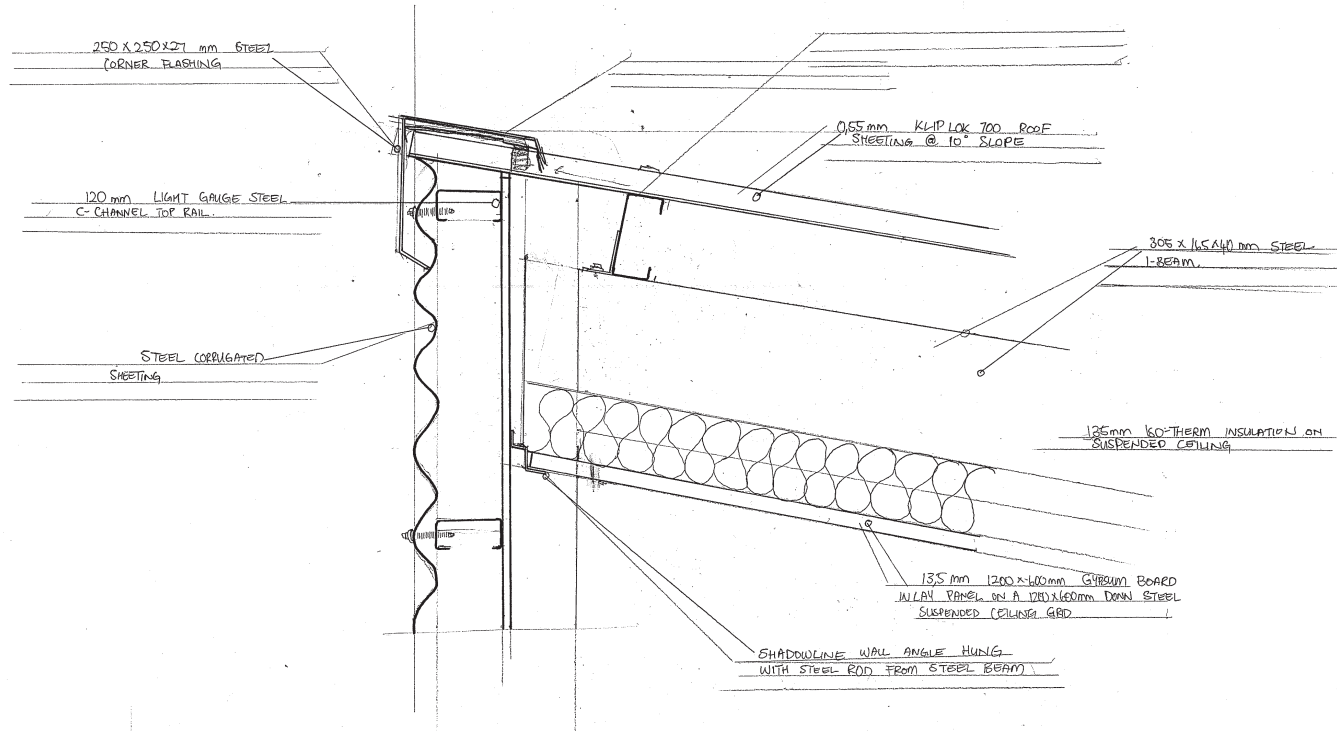

Figure 158: Roof detail N.T.S (Author 2015)

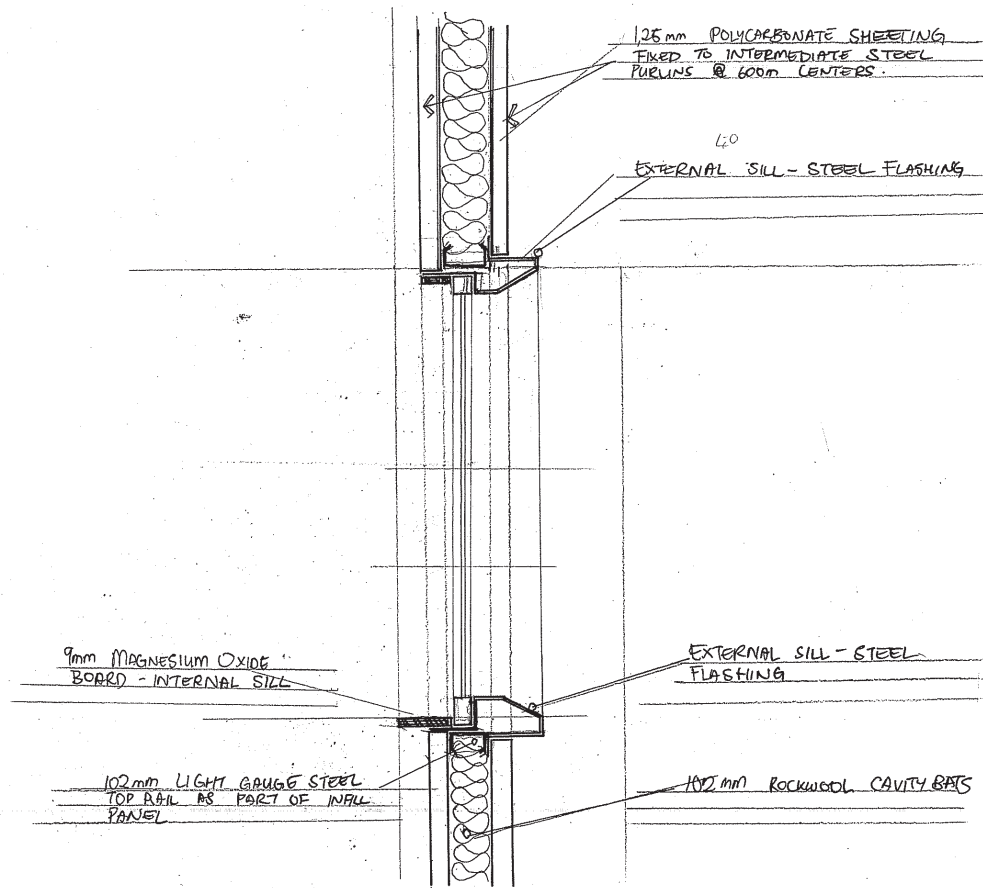

Figure 159: Window detail N.T.S (Author 2016)

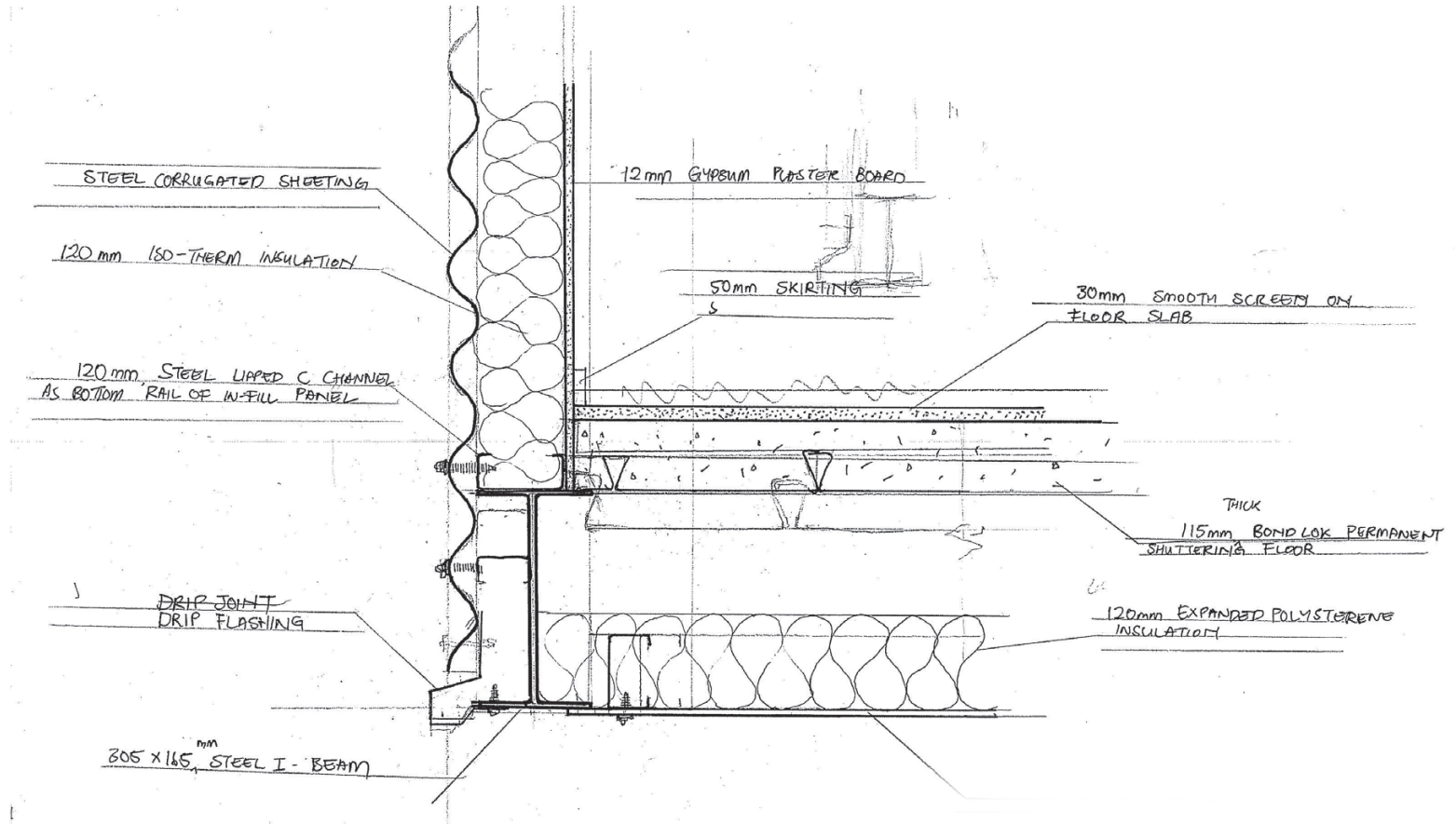

Figure 160: Wall to floor detail connection (Author 2016).

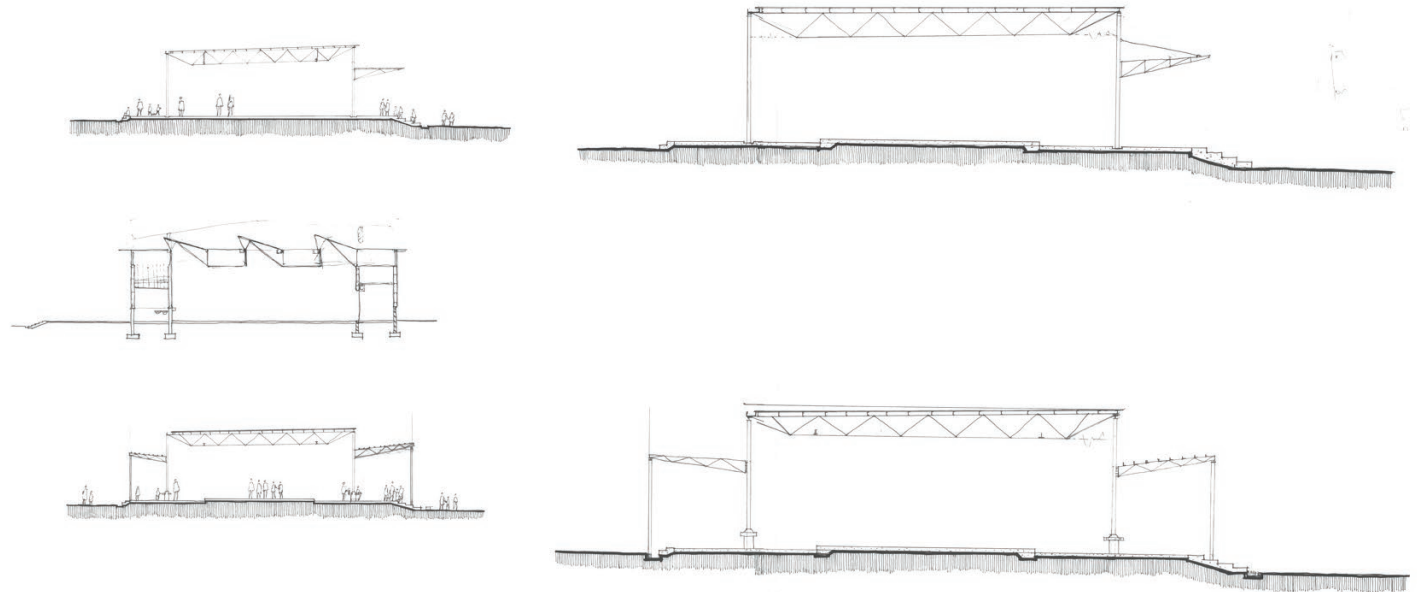

Figure 161:Community sectional development: Thresholds and structure (Author 2016).

The community hall is a portal between the communal public space and the soccer field. As such, the building has two service cores on either end with the roof beams support on the towers and the columns on the platform. A threshold space is created to celebrate the soccer field. The, roof structure and platform to column connection are investigated.

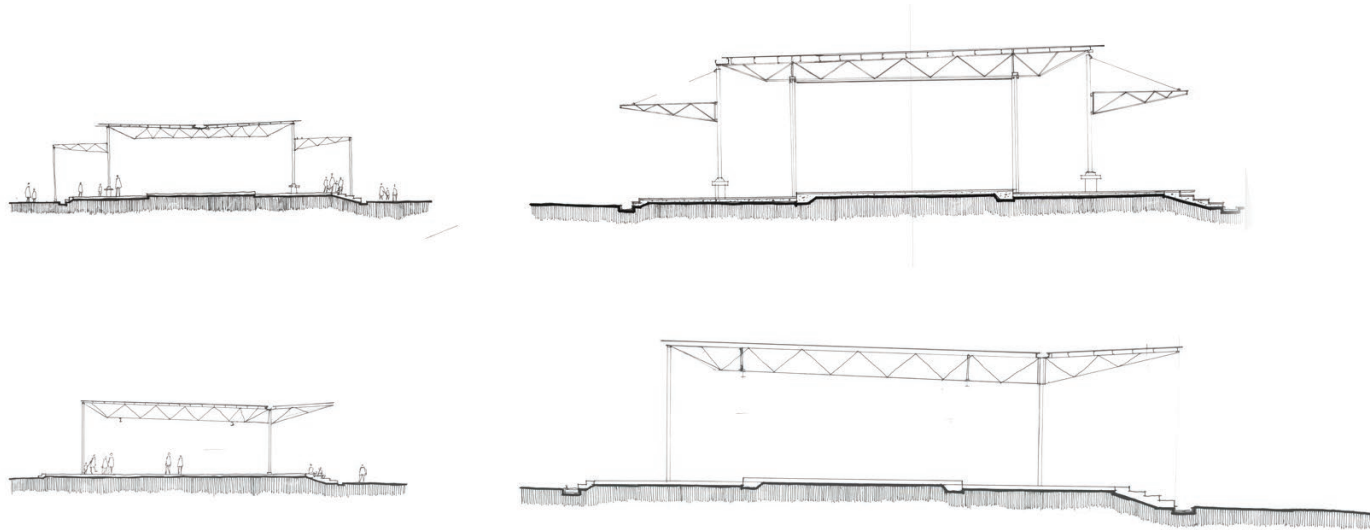

Figure 162:Community sectional development: Thresholds and structure (Author 2016).

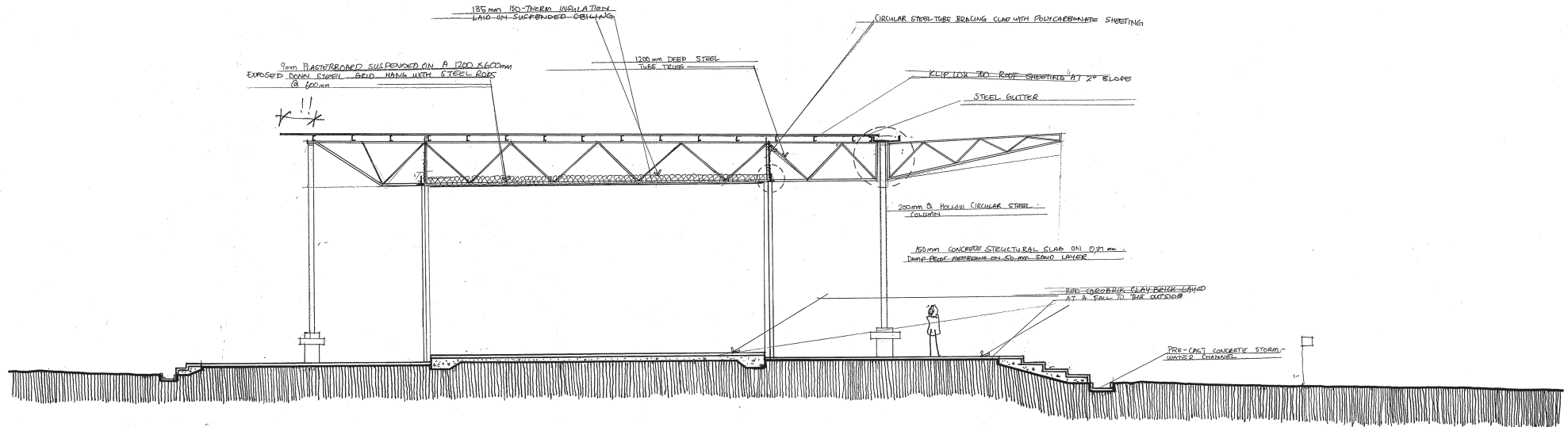

Figure 163: The community hall detail investigation (Author 2016).

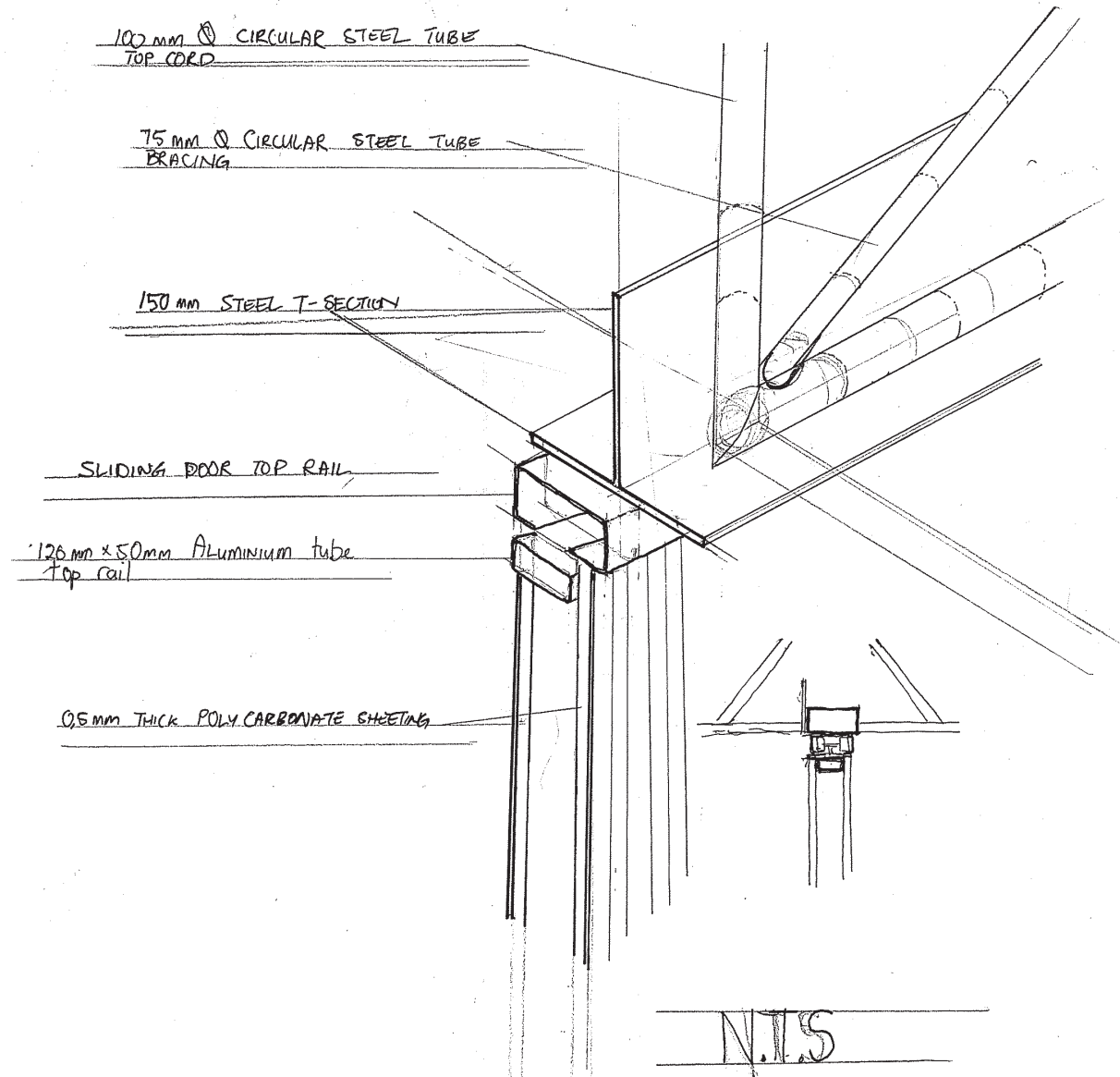

Figure 164: Detail connection of the door panel and rail to the structure of the community hall (Author 2016).

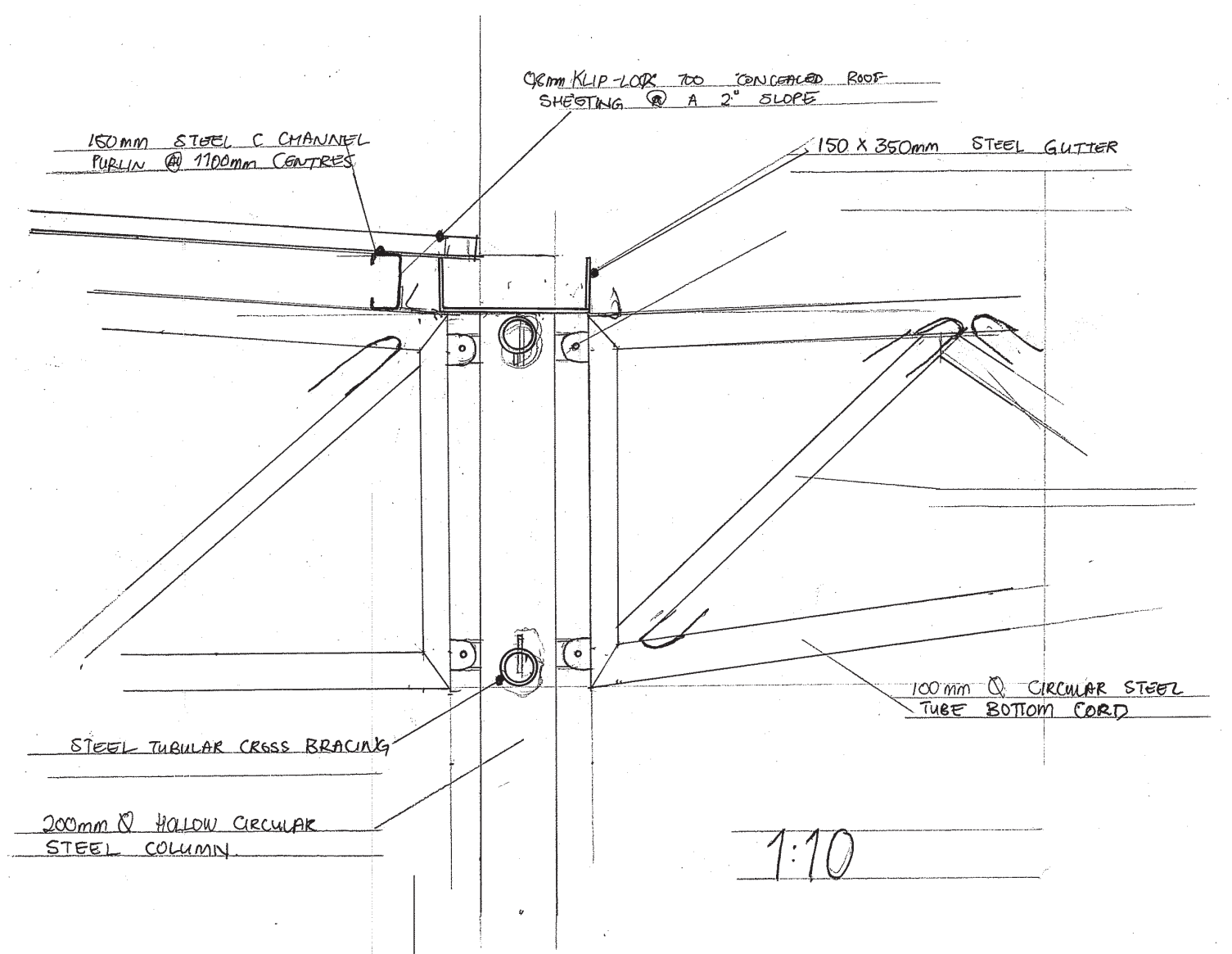

Figure 165: Beam to column and brace detail N.T.S (Author 2016).

8.9 FINAL DETAILING

The final detailing of the building brings together the detailing from the investigation of the panel system into the context of the buildings' structural frame.

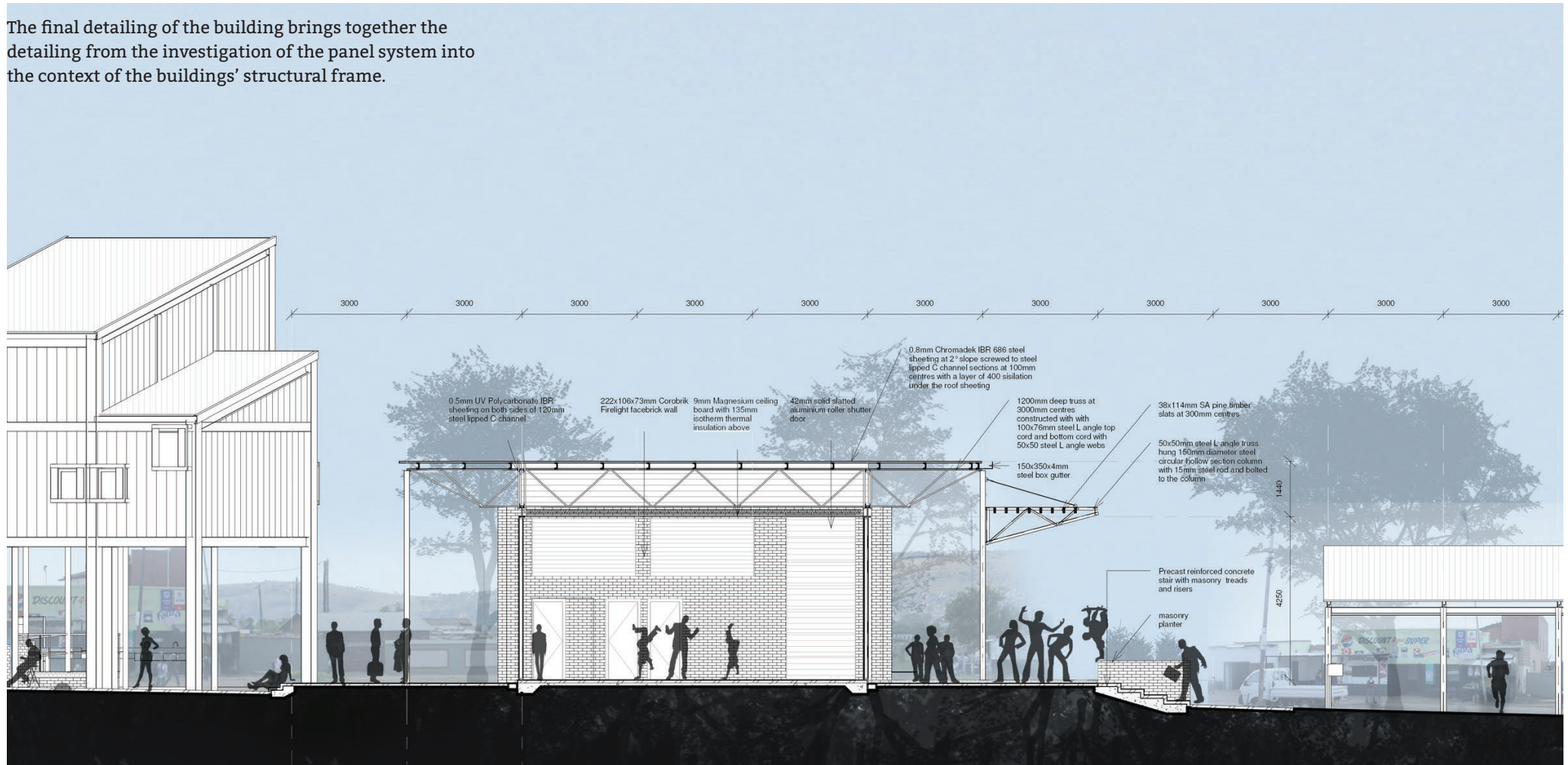

Figure 166: Hall section. 1:100 in Presentation. Section cut to show the Community Hall in context (Author 2016).

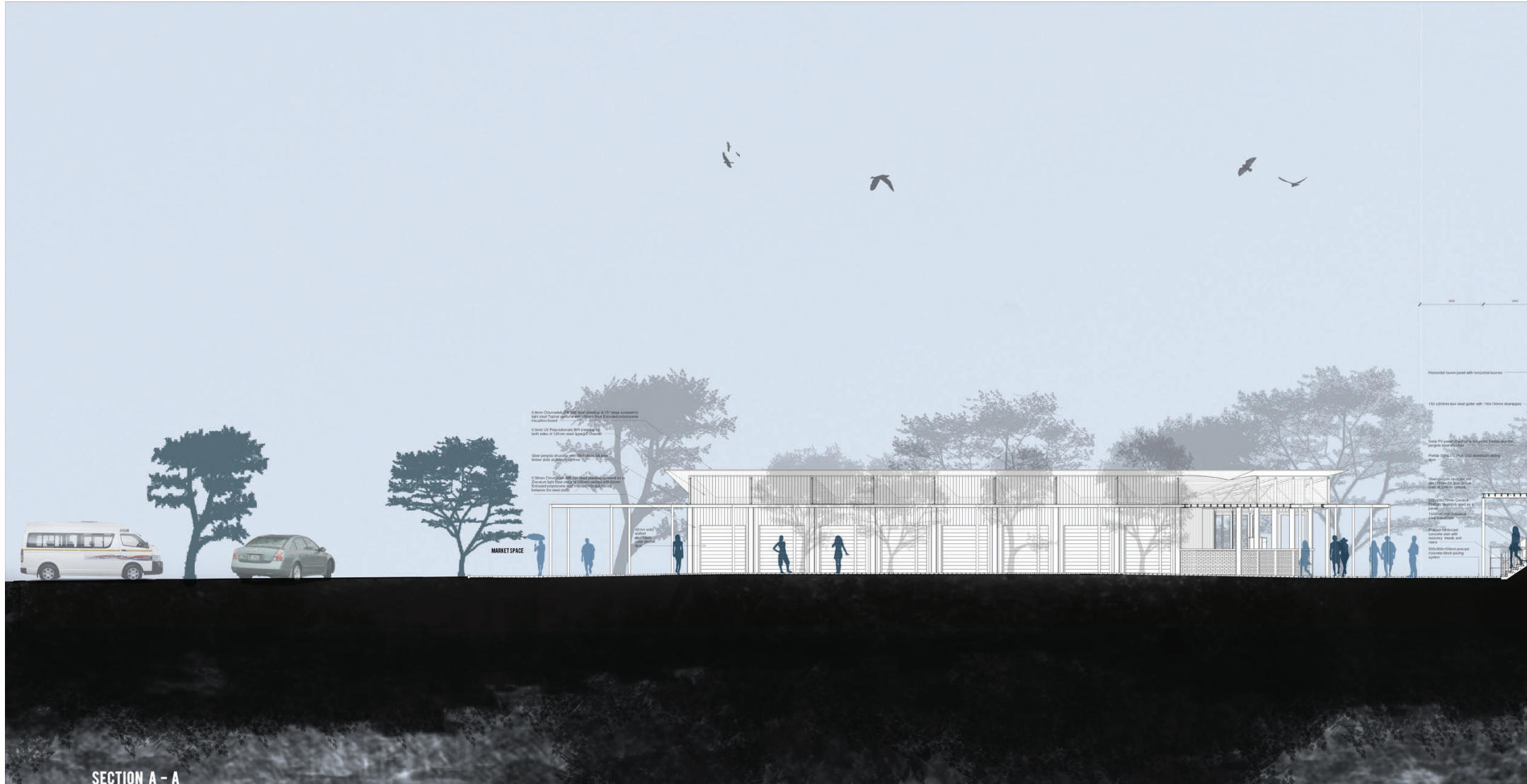

Figure 167: Administration building section. 1:50 in presentation (Author 2016).



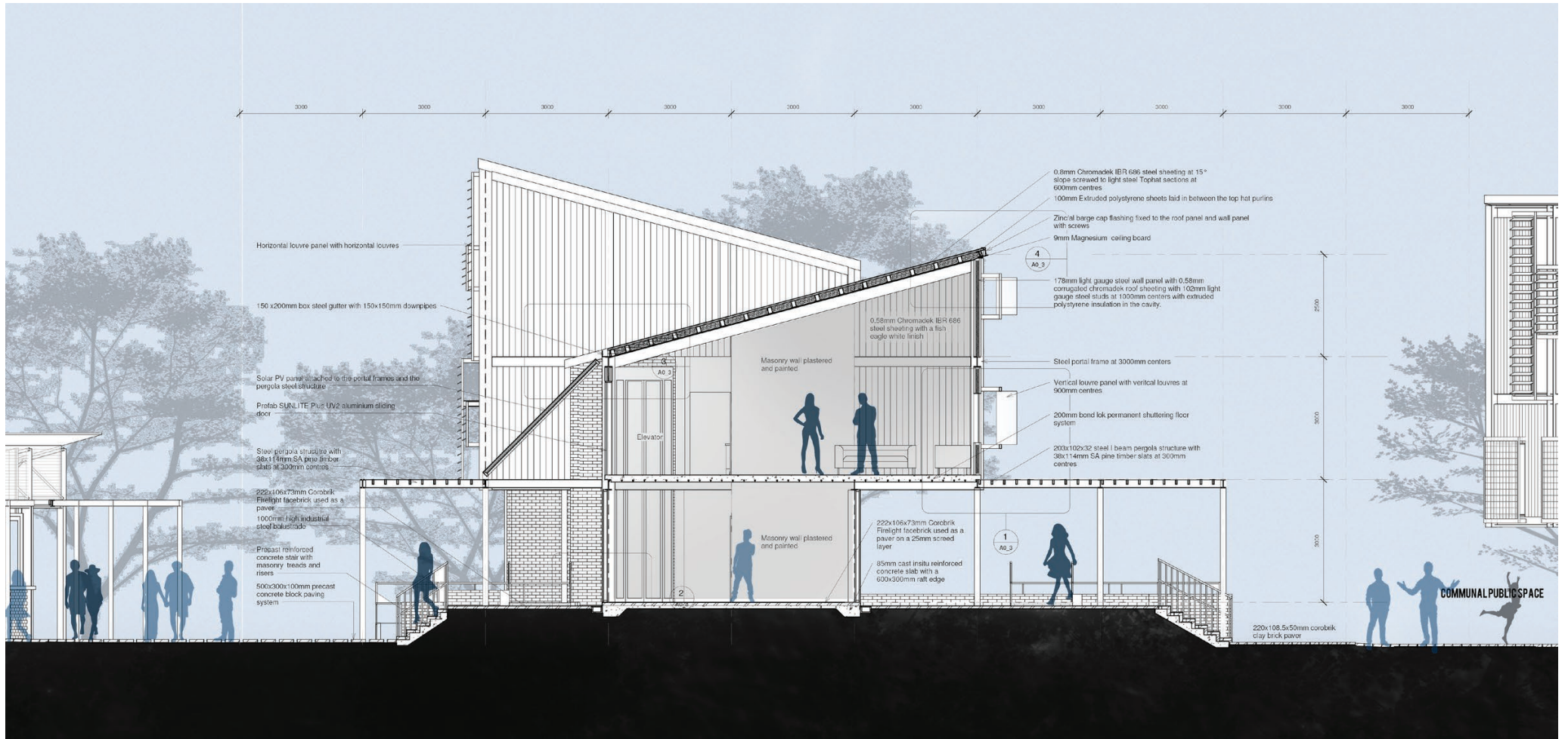
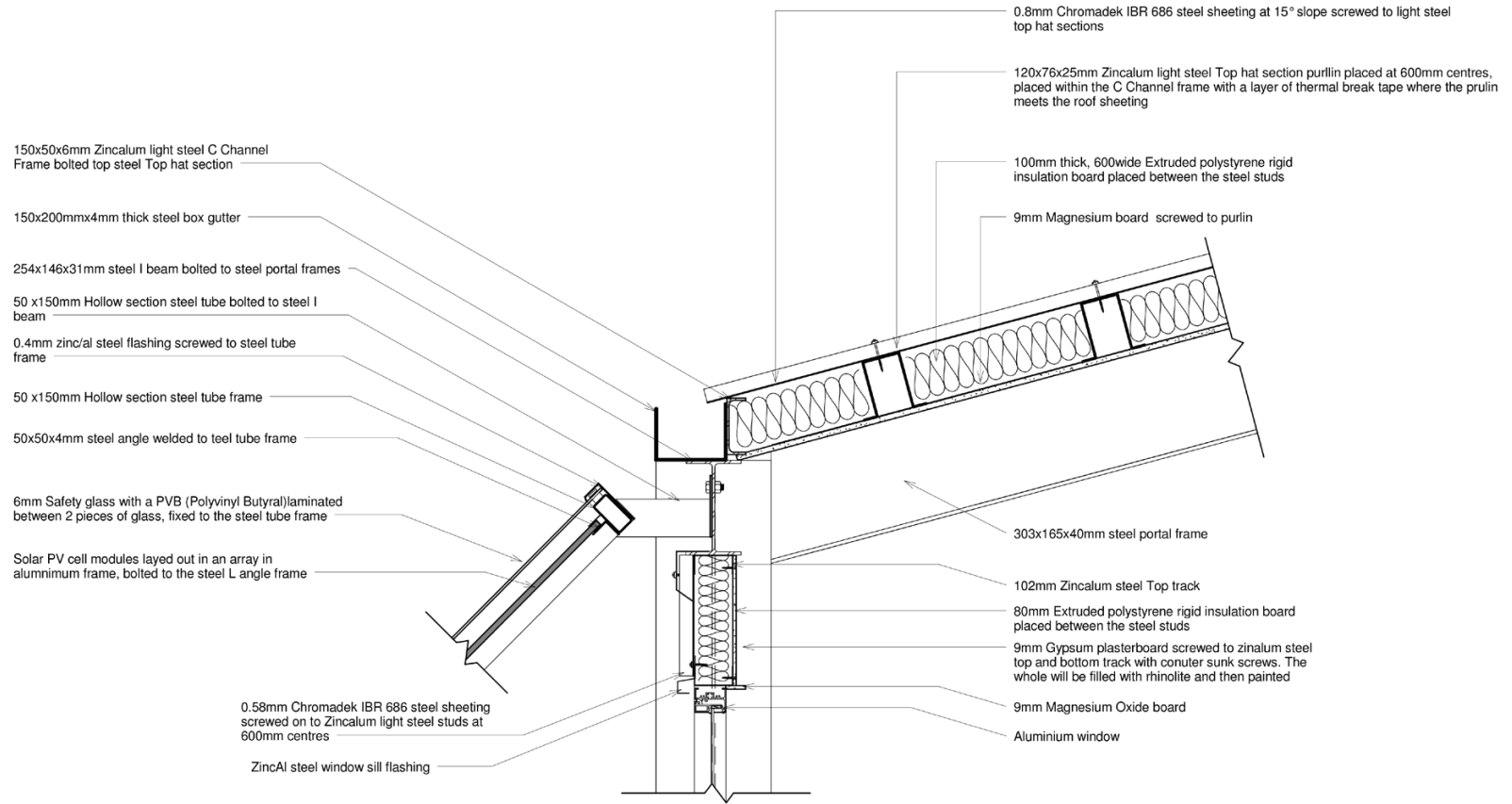
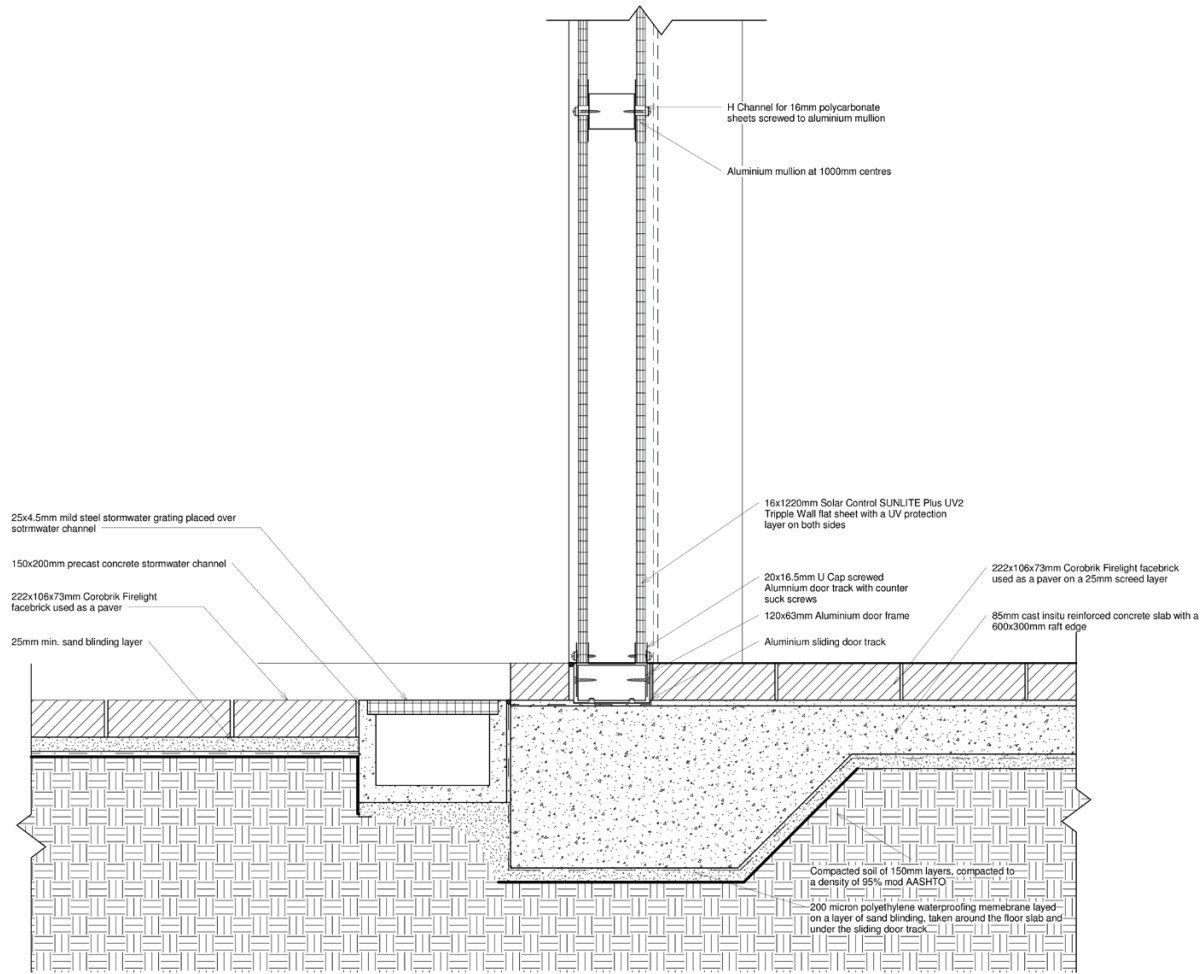

Figure 168: Administration section (Author 2016).



GUTTER / SOLAR PANEL DETAIL

Figure 169:Gutter / solar panel detail. 1:10 in Presentation (Author 2016).



2 FLOORDETAIL

Figure 170: Floor / sliding door detail. 1.5 in presentation (Author 2016).

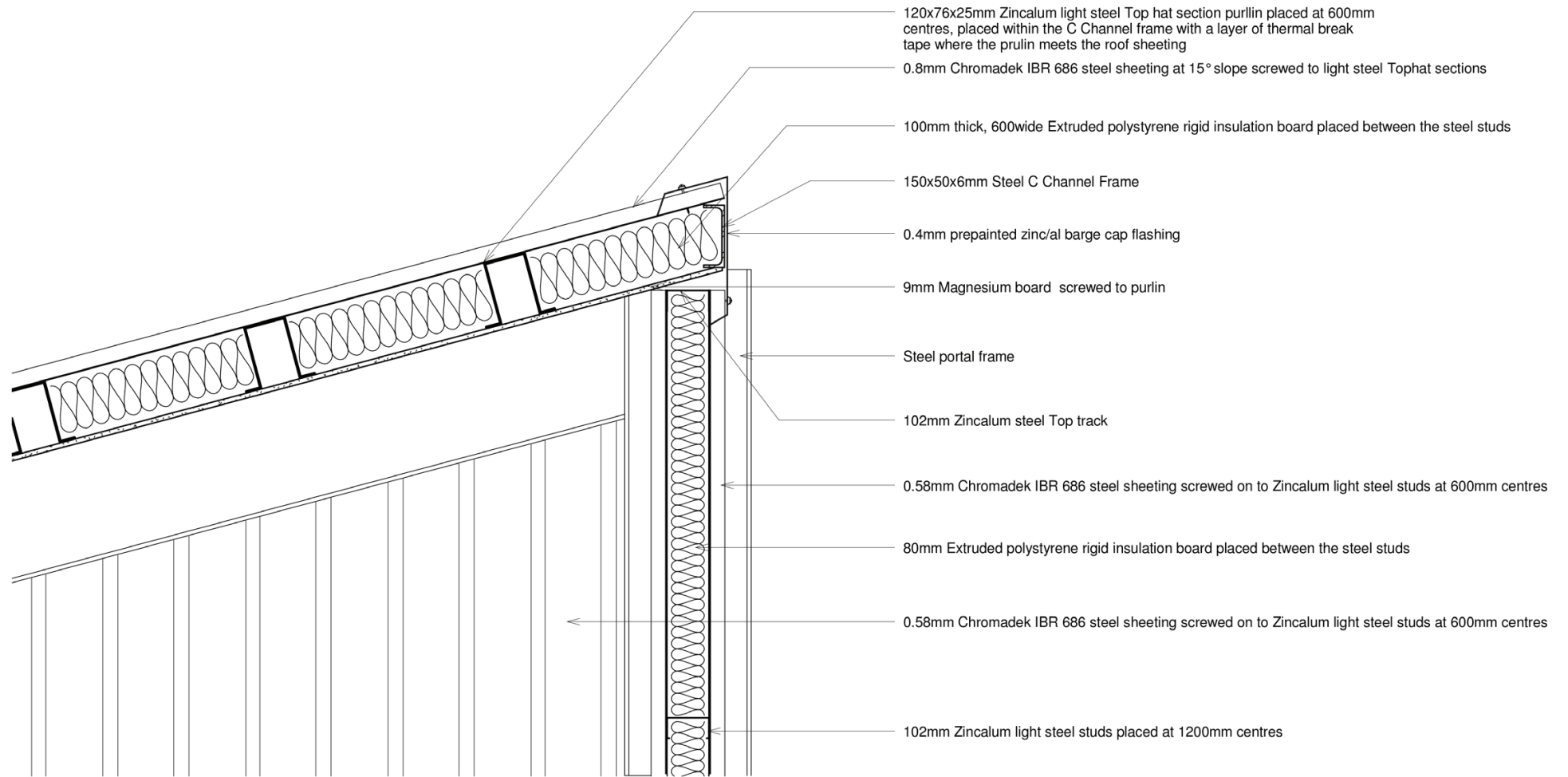

ROOF / WALL DETAIL

Figure 171:Roof to wall detail. !:5 in presentation (Author 2016).

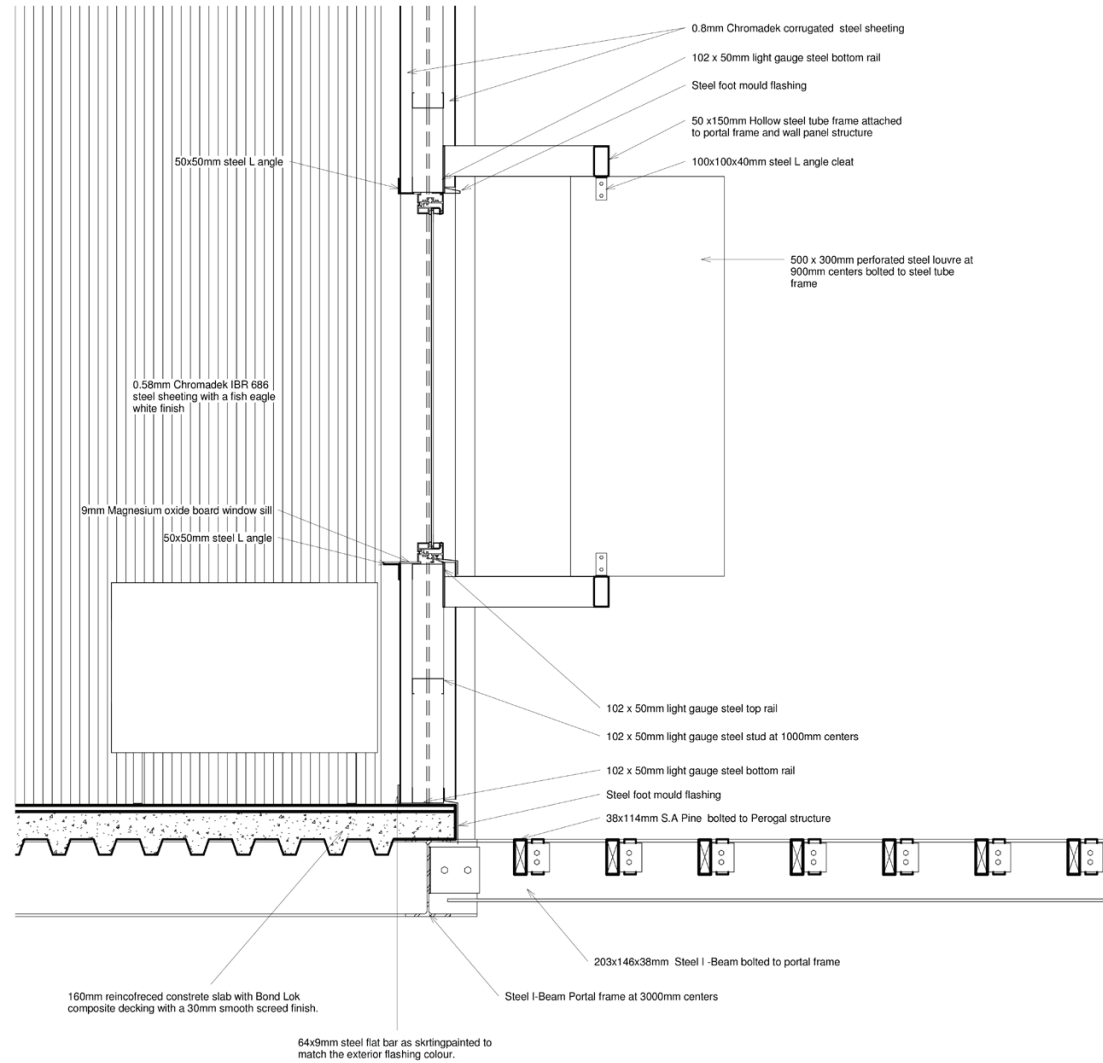

1
SUSPENDED FLOOR DETAIL

Figure 172: Suspended floor detail. 1:10 in presentation (Author 2016).

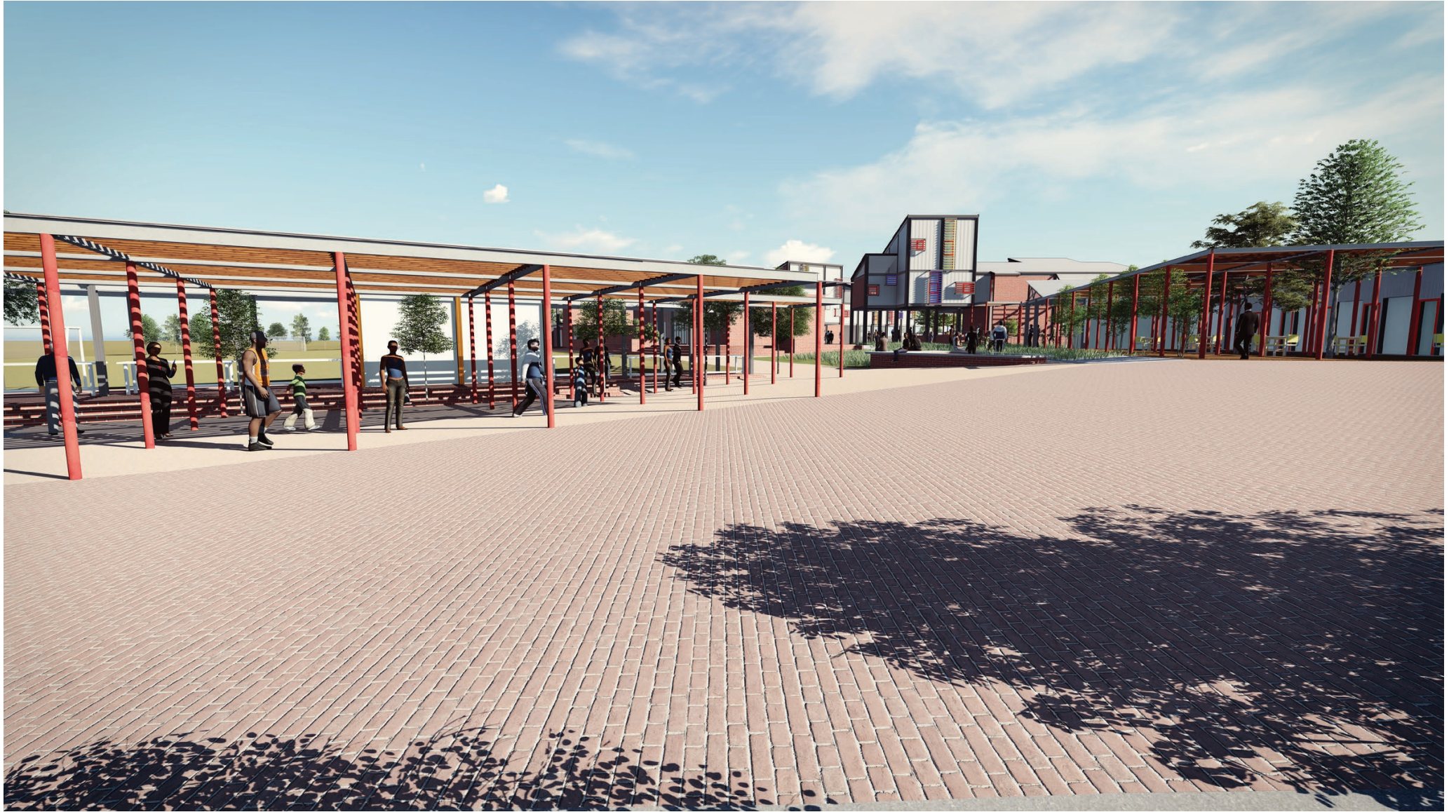

Figure 173:View from the Market Space (Author 2016).

CONCLUSION

The projects' initial intentions have been met and the project has been able to achieve architecture that not only gives access to public amenities but also access to great public spaces. The principles derived and learned in the process show the potential of place making in context similar to Lusaka. The project has been able to reimagine the way in which public amenities are implemented in a community where very few are found. It shows the potential of decentralising public services to a level where the blue collar work of a government entity can be performed by the community members, thereby actively involving them in their health and safety.

In trying to decentralise the public functions, the programme of the project has become too loose to a point where the accommodation list is general leading to an architecture that is open ended. This is both a positive and a negative factor. It allows for the building to be highly adaptable to a point that a completely function could be house the in the building but creates internal conditions that are not specific to the proposed programme. The project does not seek to create an absolute architecture but rather investigate principles that can be employed when designing in a context similar to that found in Lusaka and therefore be able to create an architecture that is appropriate to its social, economic and political contexts.

The understanding of the context and the translation of this understanding into a modular architectural system that can

be used and adapted gives value to an architectural typology that has not been widely used in the township concept. The technical investigation of the project should have occurred concurrently with the design development so that the architectural form could have been investigated more thoroughly so that the potential of the panel system could have been reached.

If Architecture is for the people, has this project achieved the intention of better serving the people in a better space? The project has made a valuable contribution to the architectural field, in a topic that is very relevant in current South Africa. The project has proposed a valid way of intervening in a context like Lusaka and has successfully shown that one is able to create a good neighbourhood where there previously wasn't.

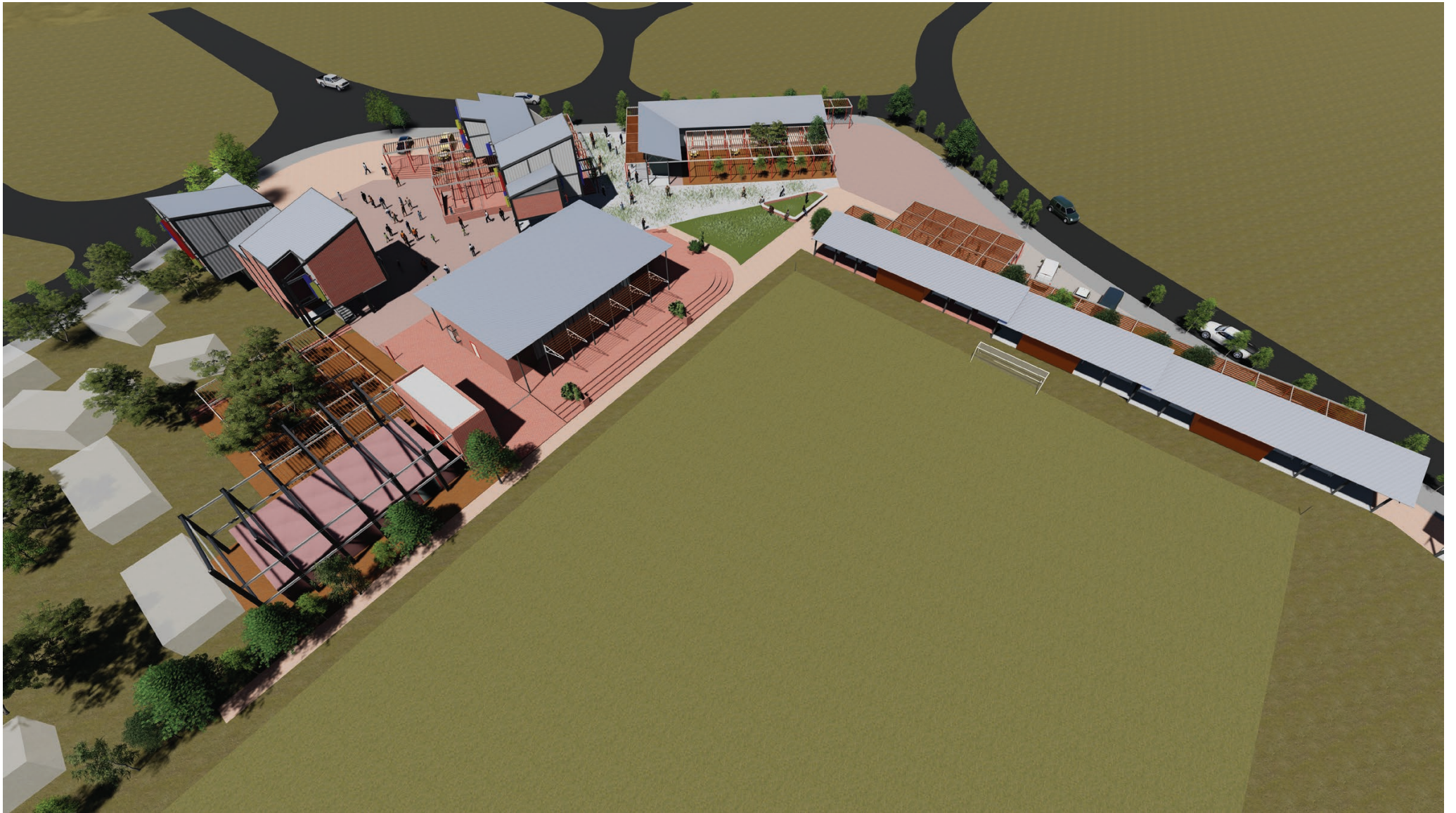

Figure 174: Aerial view of site (Author 2016).

9

ADDENDUM

9.1 FINAL MODEL



Figure 175: Final model in context (Author 2016).



Figure 176: View into communal public space (Author 2016).



Figure 177: View down Mathane Street (Author 2016).



Figure 178: Aerial view of model (Author 2016).

9.2 PRESENTATION

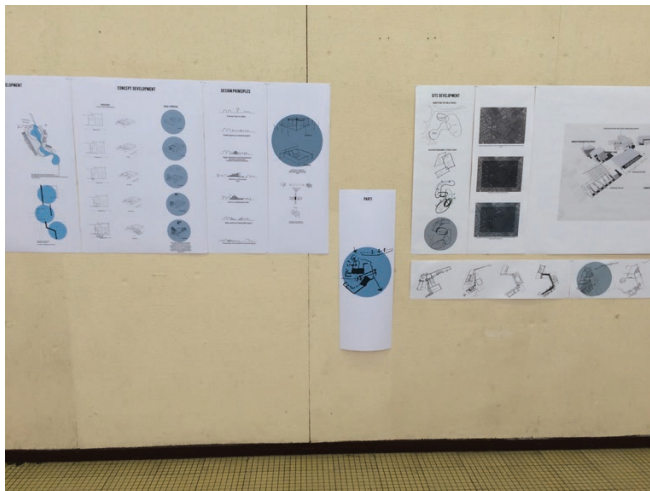
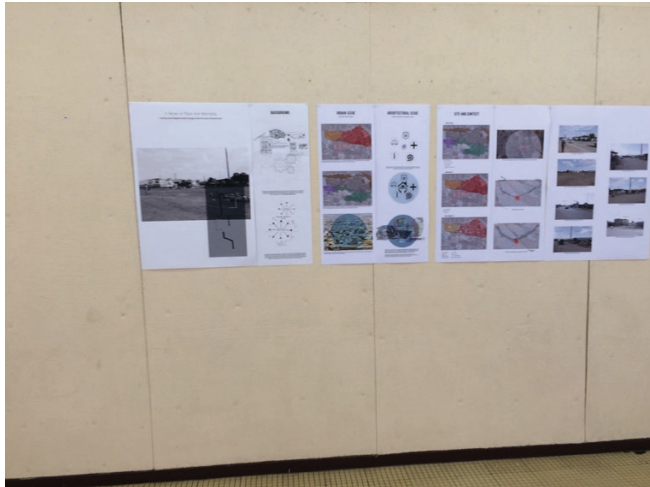
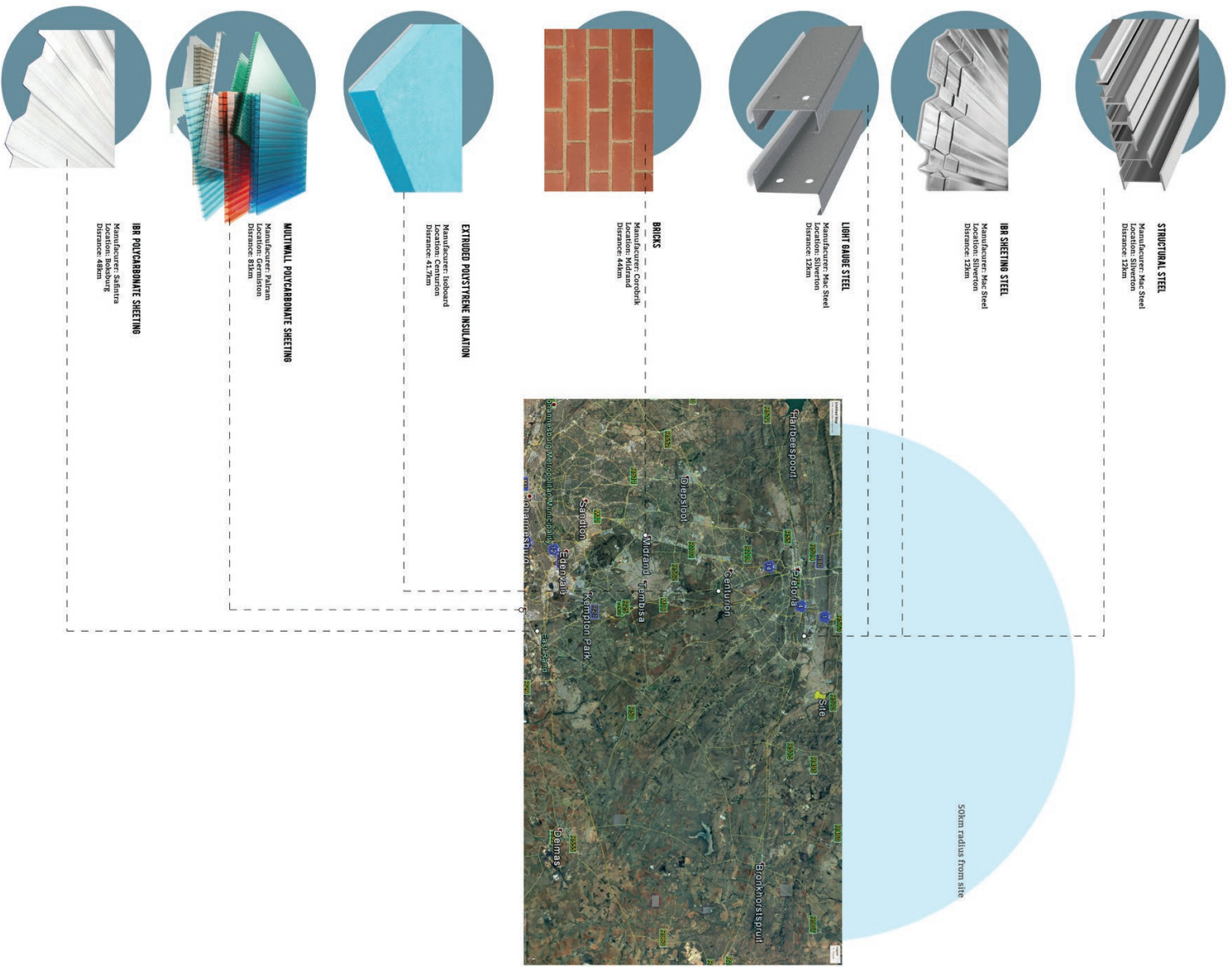

Figure 179: Presentation panels (Author 2016).

MATERIALS



9.3 MATERIALS

Figure 180: Material used in project and the distances from manufacturer and the site (Author 2016).

9.3 LETTER FROM DESIGN EXAMINER

M. (Prof) Assessment of dissertation (design component) by external examiner.

Name of candidate: Siyabonga Mahlangu

Title of Dissertation: A Sense of Place and Belonging

Name of external examiner (design): Thomas Chapman

Date: 11 Nov 2016

Comments:

GENERAL: This project asks some very relevant questions, I sincerely enjoyed being taken on the student's dynamic journey through some difficult theoretical terrain. The student's passion and interest for design is evident throughout the project and I am looking forward to finding out whether any of the research questions posed at the beginning of the document have been resolved through the design process.

STRENGTHS:

- **Precinct-scale planning:** The project demonstrates an intimate knowledge of the site and has made some very mature decisions at the urban precinct scale, with a sensitive scalar and placemaking response to context.
- **Design iterations:** The student has successfully used model-making to refine the design and the latest iteration shows that the student has developed a critical understanding of scale and context.

SHORTCOMINGS

- **Precedent Studies:** Although not directly related to the design process, my feeling is that the student could have constructed his entire argument through a far more critical review of precedent studies. I am not sure that the student has visited any of the projects in Chapter 5, as the reading and understanding of the work is thin and far too kind! My feeling is that the student should have supplemented the formal/ architect-designed projects with other successful examples of community spaces that demonstrate the type of tectonic and spatial qualities he is trying to create- in urban design we would call this a 'tissue- study'. There are some anecdotal studies of incremental growth of RDP houses but this is far too generic. I am thinking the student should showcase a successful Chisa-Nyama or carwash etc. and analyse it in minute detail.
- **Large Urban Design (Ch 3):** I find this portion of the project very naïve, and should not be termed an urban design framework, rather a research/ though framework. The interventions read as very 'top-down' proposals which contradict the students very well-considered precinct planning in later chapters (from pg 80 onwards)/.

ASPECTS THAT NEED CLARIFICATION

- **Precedent Studies:** Some kind of synthesis statement/ diagram that demonstrates a better/ more critical understanding of the precedents.
- **Overall Form:** There is a great deal of architectural information lacking in the document that I am looking forward to seeing in the final presentation.

CREDIBILITY OF ARGUMENT AND BIBLIOGRAPHY: *No Comment (Design examiner only)*



10

REFERENCES

LIST OF FIGURES

Figure 1	Diagram illustrating a new way of conceptualising the interaction between a public building and a public space (Author 2016).	6	Figure 23	Primary nodes (Mahlangu et al. 2016).	26
Figure 2	Components that make up a city (Author 2016).	2	Figure 24	Secondary nodes (Mahlangu et al. 2016).	27
Figure 3	Calderwood's plans of black native townships and the infrastructure required to make it a good neighbourhood (Calderwood 1953).	3	Figure 25	Activity spines connecting nodes (Mahlangu et al. 2016).	27
Figure 4	Service Provision Collage (Adapted by Author 2016).	4	Figure 26	Proposed nodal development and activity spine activation (Mahlangu et al. 2016).	28
Figure 5	Architectural Intention Collage (Adapted by Author 2016).	4	Figure 27	Phased growth of street (Mahlangu et al. 2016).	28
Figure 6	The intervention as the "in-between" formal and informal (Author 2016).	5	Figure 28	Existing attributes of Lusaka and the proposed precinct location (Mahlangu & Wolmarans 2016).	32
Figure 7	NE 51/9 House developed by the CSIR (Author 2016).	8	Figure 29	Proposed Urban Hub, Mahube Max City Mall, Mamelodi (Mahlangu & Wolmarans 2016)	32
Figure 8	Bufferzones that define Mamelodi (Author 2016).	9	Figure 30	Points of interests and nodes linked to Bophelo Precinct (Mahlangu & Wolmarans 2016)	33
Figure 9	Density map (Author 2016).	10	Figure 31	Points of interest around Pienaarspoort Train Station (Mahlangu & Wolmarans 2016)	33
Figure 10	Formal and informal housing (Author 2016).	11	Figure 32	Pedestrian movement around the precinct where the best suited interventions will be implemented (Mahlangu & Wolmarans 2016)	34
Figure 11	Public Amenities in Mamelodi (Author 2016).	12	Figure 33	Existing zones of interest. This will be incorporated in the precinct proposal with various interventions (Mahlangu & Wolmarans 2016).	34
Figure 12	Site location and extent of reach of the intervention (Author 2016).	13	Figure 34	Proposed activities and interventions for the green route (Mahlangu & Wolmarans 2016).	35
Figure 13	Site edges and constraints (Author 2016).	14	Figure 35	Proposed networks that will supplement the larger civic proposal that form part of the precinct plan (Mahlangu & Wolmarans 2016).	35
Figure 14	Energy flow and movement of people and vehicles (Author 2016).	15	Figure 36	Network diagram of nodes linked by activity spine (Mahlangu & Wolmarans 2016).	36
Figure 15	The street as a public space (Author 2016).	16	Figure 37	Precinct development plan (Mahlangu & Wolmarans 2016).	36
Figure 16	Shacks that are marked and recognised by the municipality (Author 2016).	17	Figure 38	Summary block of development interventions (Mahlangu & Wolmarans 2016).	37
Figure 17	One of few recreational spaces and religious building (Author 2016).	18	Figure 39	Functional categories of public facilities (CSIR 2009: 2).	40
Figure 18	Movement and energy flow across the site (Hector Peterson Road (Author 2016).	19	Figure 40	Functional categories of public facilities (CSIR 2009: 2).	41
Figure 19	Commercial edges of the site (Tshukudu Street) (Author 2016).	20	Figure 41	Programme (Author 2016).	42
Figure 20	Architectural language as signs of aspiration (Author 2016).	21			
Figure 21	The daily exodus (Mahlangu et al. 2016).	25			
Figure 22	Existing and proposed urban cores (Mahlangu et al. 2016).	26			

Figure 42	Material palette (Author 2016).	45	Figure 60	Soccer match on Victory soccer field [Lusaka, Mamelodi] (Author 2016).	61
Figure 43	Definition of public space (Author 2016).	45	Figure 61	Market spaces where people socialise and earn a living [Lusaka, Mamelodi] (Author 2016).	62
Figure 44	The building blends well with the context of Alexandra (Baan 2010).	46	Figure 62	Stakeholders of the design project (Author 2016).	65
Figure 45	The skin of the building is different depending on the orientation of the wall and the function within the building (Author 2016).	47	Figure 63	Network of Hubs which connect to phase 2, the proposed civic intervention (Author 2016).	66
Figure 46	The Building is a light mass placed over the roof of an existing community hall. The community hall becomes the podium for the building (Author 2016).	47	Figure 64	The growth of street side spaza in Mamelodi Gardens, Mamelodi East (Author 2016).	67
Figure 47	Material honesty as principle that embodies the characteristic of the material use of existing buildings in the immediate context (Local Studio 2015).	48	Figure 65	Potential growth of a typical hub (Author 2016).	69
Figure 48	The taxi rank within its context (Baan n.d.).	50	Figure 66	Shacks and RDP buildings in Lusaka (Author 2016).	70
Figure 49	The linear market and public porch as the thresholds between the rank and the street (Author 2016).	50	Figure 67	Urban plan sketch derived from understanding the context and incorporating in the urban vision (Author 2016).	71
Figure 50	Active box along a route as balls on a string (Author 2016).	51	Figure 68	The public space becomes the most important space and the intervention is based on these spaces. (Author 2016).	72
Figure 51	An Active box proximity to a recreational space (Dayton 2014).	52	Figure 69	The public spaces will have qualities from a square typology to a linear typology (Author 2016).	73
Figure 52	The Active Box is always placed close to a public space. It fosters a safe zone between the public space and residential zone (Author 2016).	52	Figure 70	Partii Diagram. The public spaces will be controlled by grid and small structures to loosely define space (Author 2016).	73
Figure 53	Typical Koban (Thomas 2016).	53	Figure 71	Concept model	74
Figure 54	Contemporary Koban within the city (Klein Dytham Architecture 2012).	54	Figure 72	Concept model	75
Figure 55	African public and private space [Diptych of a street market in Soweto on the left and a menstruation hut in Sangha on the right] (Adapted by Author 2016).	57	Figure 73	Concept model	75
Figure 56	European private and public spaces. [Piazza della Signoria on the left and a Suburb in Colorado Springs on the right] (Adapted by Author 2016).	57	Figure 74	Concept model	76
Figure 57	Street edge activity [Hector Peterson road in Lusaka, Mamelodi] (Author 2016).	58	Figure 75	Design principles employed in developing the intervention (Author 2016).	77
Figure 58	Informal settlement patterns and dwellings as lessons in rationalistic design [Alaska, Mamelodi] (Author 2016).	59	Figure 76	Temporality and permanence (Author 2016).	78
Figure 59	An existing church found on site. Religion forms a part of the daily rituals on the site (Author 2016).	60	Figure 77	Synthesis of the qualities of both temporality and permanence (Author 2016).	78
			Figure 78	Identifying public and structuring the internal programmes according to the public spaces (Author 2016).	79
			Figure 79	Definition of public spaces A. Existing activities and spaces on the site are defined and the arrows show the relation to the street. B. The edges	

	of the proposed building are shown. C, the various components of the building and their relations to the street and the public spaces around them are illustrated.	80	Figure 100	Elevations of building within context(Author 2016).	100
Figure 80	Massing model that defines the 3 public spaces on its edges (Author 2016).	81	Figure 101	Marquette of building in the landscape. Aerial view (Author 2016).	101
Figure 81	Massing model that defines the 3 public spaces on its edges (Author 2016).	81	Figure 102	Marquette of building in the landscape. Aerial view from the soccer field (Author 2016).	102
Figure 82	Parti Diagram (Author 2016).	82	Figure 103	Marquette of building in the landscape. Aerial View (Author 2016).	103
Figure 83	Site Plan development. (Author 2016). The proposed public spaces are related to the programmes in the building.	84	Figure 104	Marquette of building in the landscape. View from residential side of the building. (Author 2016).	104
Figure 84	Site Plan Development (Author 2016). The existing pedestrian movement across the site is maintained and visual links between the street and the public spaces are created so that the spaces are not closed off from each other .	85	Figure 105	Layout and scale of buildings are redesigned to achieve the initial intentions.(Author 2016)	105
Figure 85	Illustration of the public spaces (Black) and the structures that define the spaces (Author 2016).	86	Figure 106	Site plan on the left and ground floor plan iteration on the right (Author 2016).	106
Figure 86	Draft site plan illustrating the response to the street edge, public spaces and existing view across the site. N.T.S(Not to scale) (Author 2016).	87	Figure 107	Investigating thresholds between the building and the landscape (Author 2016).	107
Figure 87	3x3meter grid used to control both building and landscape (Author 2016).	88	Figure 108	Redesigning the street edge of Hector Peterson Rd. and the thresholds to the market stalls (Author 2016).	108
Figure 88	Massing model. (Author 2016)	89	Figure 109	Sketch of landscape and roofs as thresholds.(Author 2016).	108
Figure 89	Massing model. (Author 2016)	90	Figure 110	The iterated ground floor plan (Author 2016).	109
Figure 90	Massing model. (Author 2016)	91	Figure 111	The iterated first floor plan (Author 2016).	110
Figure 91	Massing model. (Author 2016)	92	Figure 112	Marquette. Aerial View. The model shows the character of the architecture in relation to the space around it (Author 2016).	111
Figure 92	Site Plan (Author 2016)	93	Figure 113	Marquette. Aerial View. The model shows the character of the architecture in relation to the space around it (Author 2016).	112
Figure 93	Ground floor plan. N.T.S (Author 2016).	94	Figure 114	Marquette. Aerial view from the residential side of the site. The model shows the character of the architecture in relation to the space around it (Author 2016).	113
Figure 94	First floor plan (Author 2016).	94	Figure 115	Marquette. View across Hector Peterson Road and the primary school. The model shows the character of the architecture in relation to the space around it (Author 2016).	114
Figure 95	Section through the public spaces.(Author 2016).	95	Figure 116	Marquette. View from across the soccer field. The model shows the character of the architecture in relation to the space around it (Author 2016).	115
Figure 96	Section through the public spaces.(Author 2016).	96			
Figure 97	Sections through the building (Author 2016).	97			
Figure 98	Sections through the building (Author 2016).	98			
Figure 99	Elevations of building within context(Author 2016).	99			

Figure 117	3D rendering as you enter from the Market space (Author 2016).	116	Figure 137	The formation of the grid and how changes can be implemented through it (Author 2016).	139
Figure 118	Site plan. 1:500 in presentation (Author 2016).	117	Figure 138	The grid and how it is uses the platform to create a building and a link to the landscape (Author 2016).	140
Figure 119	Ground floor plan . 1:200 in presentation. (Author 2016).	118	Figure 139	Exploded view of a shack panel. The shack panel elements are reinterpreted to create a new architectural language (Author 2016).	140
Figure 120	First floor plan. 1:200 in presentation (Author 2016).	119	Figure 140	The construction and adaptation of the building (Author 2016).	141
Figure 121	3D rendering. View as you enter from the Market space (Author 2016).	120	Figure 141	The panel in the various forms. (Author 2016)	143
Figure 122	Northern Street Elevation [Hector Peterson Road]. Clay rendering (Author 2016)	121	Figure 142	Variations of the panel (Author 2016).	144
Figure 123	Northern Street Elevation [Hector Peterson Road] (Author 2016).	122	Figure 143	Basic corrugated steel wall panel and its components (Author 2016).	145
Figure 124	Western Street Elevation [Tshukudu Street]. Clay rendering (Author 2016)	123	Figure 144	Wall panel. Corrugated steel and magnesium board or gypsum board as an interior finish (Author 2016).	147
Figure 125	Western Street Elevation [Tshukudu Street] (Author 2016).	124	Figure 145	Wall panel. Polycarbonate sheeting with a UV layer placed on bot the interior and exterior (Author 2016).	149
Figure 126	Section through the Community Hall. 1:100 in the presentation (Author 2016).	126	Figure 146	Wall panel. This is a custom wall panel. This item will be used for non-modular infill panels (Author 2016).	151
Figure 127	Section through the Church and the courtyard. 1:100 in the presentation (Author 2016).	128	Figure 147	Sliding door panel. This sliding door is used in the administration building and the community hall (Author 2016).	153
Figure 128	Tectonic concept. (Author 2016)	130	Figure 148	Roof panel. The panel is a modular element (Author 2016).	155
Figure 129	The platform and the process the building begins to grow from it (Author 2016).	131	Figure 149	The solar panel. This becomes an attachment to the building and works with the 3x3x3 grid (Author 2016).	157
Figure 130	The RDP house and the shack, and the materials [Lusaka, Mamelodi] (Author 2016).	132	Figure 150	Shading system. The modular system leads to a building with no overhangs over the fenestration. The system allows the building to perform better climatically (Author 2016).	159
Figure 131	The relationship between the platform, the grid and the building. Tectonic concept (Author 2016).	133	Figure 151	Shading system (Author 2016).	161
Figure 132	Grid and Aces the building layout and structure are based (Author 2016).	133	Figure 152	The adapting of the building over time (Author 2016).	163
Figure 133	Reimagining the solar panel (Adapted by Author 2016).	135	Figure 153	3D rendering of the building in its adapted phase with both panels and attachments (Author 2016).	165
Figure 134	Water cooling + heating and cooling strategy (Adapted by Author 2016).	136	Figure 154	3D rendering of the building in its adapted phase with both panels and attachments (Author 2016).	166
Figure 135	Section of the East gate building illustrating the movement of air through the building due to the passive ventilation strategy used (Sustainabilityworkshop.autodesk.com n.d.)	137			
Figure 136	Illustration of ventilation strategies used in the building (Author 2016).	138			

Figure 155	Admin building sections (Author 2016).	167	Figure 179	Presentation panels (Author 2016).	192
Figure 156	Admin building sections (Author 2016).	168	Figure 180	Material used in project and the distances from manufacturer and the site (Author 2016).	193
Figure 157	Technical exploration of the administration building N.T.S (Author 2016).	169			
Figure 158	Roof detail N.T.S (Author 2015)	170			
Figure 159	Window detail N.T.S (Author 2016)	171			
Figure 160	Wall to floor detail connection (Author 2016).	172			
Figure 161	Community sectional development: Thresholds and structure (Author 2016).	173			
Figure 162	Community sectional development: Thresholds and structure (Author 2016).	174			
Figure 163	The community hall detail investigation (Author 2016).	175			
Figure 164	Detail connection of the door panel and rail to the structure of the community hall (Author 2016).	176			
Figure 165	Beam to column and brace detail N.T.S (Author 2016).	177			
Figure 166	Hall section. 1:100 in Presentation. Section cut to show the Community Hall in context (Author 2016).	178			
Figure 167	Administration building section. 1:50 in presentation (Author 2016).	180			
Figure 168	Administration section (Author 2016).	181			
Figure 169	Gutter / solar panel detail. 1:10 in Presentation (Author 2016).	182			
Figure 170	Floor / sliding door detail. 1:5 in presentation (Author 2016).	183			
Figure 171	Roof to wall detail. 1:5 in presentation (Author 2016).	184			
Figure 172	Suspended floor detail. 1:10 in presentation (Author 2016).	185			
Figure 173	View from the Market Space (Author 2016).	186			
Figure 174	Aerial view of site (Author 2016).	188			
Figure 175	Final model in context (Author 2016).	190			
Figure 176	View into communal public space (Author 2016).	190			
Figure 177	View down Mathane Street (Author 2016).	191			
Figure 178	Aerial view of model (Author 2016).	191			

BIBLIOGRAPHY

- o 2610 South Architects. (n.d). Site Plan [jpeg]. 2610south.co.za. Available from: <http://www.2610south.co.za/gallery7.php>. [Accessed 25 April 2016]
- o 2610south.co.za. [n.d.]. 26'10 South Architects in Johannesburg. Available at: <http://www.2610south.co.za/gallery7.php> [Accessed: 25 April 2016].
- o ArchDaily. 2010. Alexandra Interpretation Centre / Peter Rich Architects. Available from: <http://www.archdaily.com/58495/alexandra-interpretation-centre-peter-rich-architects> [Accessed: 20 May 2016].
- o Archidatum.com. 2015. Alexandra Interpretation Centre / Peter Rich Architects. Available from: <http://www.archidatum.com/projects/alexandra-interpretation-centre-peter-rich-architects/> [Accessed: 20 July 2016].
- o Baan, I. (n.d). Informal-extension-no-2-8-entrance [jpeg]. 2610south.co.za. Available from: <http://www.2610south.co.za/gallery7.php>. [Accessed 25 April 2016]
- o Baan, I. 2010. Alexandra Interpretation Centre / Peter Rich Architects [jpeg]. N.T.S. Archdaily.com. Available from: http://images.adsttc.com/media/images/5008/fa0c/28ba/0d27/a700/1054/large_jpg/stringio.jpg?1414080126. [Accessed: 23 May 2016]
- o Calderwood, D.M. 1953. An investigation into the planning of urban native housing South Africa. Doctoral thesis. The University of the Witwatersrand, Johannesburg. Available from: <http://wiredspace.wits.ac.za/handle/10539/11249> [Accessed: 17 February 2016].
- o Crosset, P. (n.d). Soweto - South Africa [jpeg]. africa.quora.com/African-Markets. Available from: https://qph.ec.quoracdn.net/main-qimg-610d4df1f916d-443607091b7823e23c3-c?convert_to_webp=true. [Accessed: 2 September 2016]
- o CSIR. 2009. Guidelines to Human Settlement Planning and Design, Vol.1, Available from: http://www.csir.co.za/Built_environment/Redbook/Vol_I/Volume_I.pdf > [Accessed: 3 April 2016].
- o Dayton, S. 2014. Tour of VPUU active box in Harare, Khayelitsha. [jpeg]. [www.twitter.com](https://twitter.com/daytoncapetown/status/472380440125644800). Available from: <https://twitter.com/daytoncapetown/status/472380440125644800>. [Accessed: 22 July 2016]
- o Doan, A. 2012. BIOMIMETIC ARCHITECTURE: Green Building in Zimbabwe Modeled After Termite Mounds. Inhabitat.com. Available from: <http://inhabitat.com/building-modelled-on-termites-eastgate-centre-in-zimbabwe/> > [Accessed :10 October 2016].
- o Foster, J. 2012. Review. African Identity in Post-Apartheid Public Architecture: White Skin Black Mask by J.A Noble. *Traditional Dwellings and Settlements Review*, 23(2), 86-87.
- o Futurecommunities.net. 2016. Lack of social infrastructure affects community wellbeing | Future Communities. Available from: <http://www.futurecommunities.net/socialdesign/188/lack-social-infrastructure-affects-community-wellbeing> > [Accessed: 13 March 2016].
- o Graham, G. 2006. Can There Be Public Architecture?. *The Journal of Aesthetics and Art Criticism*, 64(2), 243-249.
- o Haarhof, E.J. 2011. Appropriating modernism: Apartheid and the South African township. School of Architecture and Planning University of Auckland, New Zealand. Available from: <http://www.az.itu.edu.tr/azv8no1web/16-haarhoff-08-01.pdf> > [Accessed: 16 February 2016]
- o Hirshen, S. & Dovey, K. 1989. Public Service Architecture. *JAE*, 35(1), 28-31.
- o Hunter, F & Hunter D. 2012. Ritual compound, Sangha, with menstruation hut [jpeg]. <http://www.travelsinafrica.com/>. Available from: <http://www.travelsinafrica.com/wp-content/uploads/2012/12/Menstruation-hut-Sangha.jpg>. [Accessed: 2 September 2016]
- o Japanvisitor.com. 2016. Koban | JapanVisitor Japan Travel Guide. Available at: <http://www.japanvisitor.com/japanese-culture/koban> > [Accessed: 3 May 2016].
- o Johannesburg Development Agency [Jda.org.za]. 2014. Diepsloot taxi rank upgrade a welcome change. Available at: <http://www.jda.org.za/latest-news/1481-jda-diepsloot-taxi-rank-upgrade-a-welcome-change> > [Accessed: 25 April 2016].
- o Klein Dytham Architecture. 2012. kob03 [jpeg]. Urbanpeek.com. Available from: <http://urbanpeek.com/wp-content/uploads/2012/04/Koban-Police-Station-3-e1334427103381.jpg>. [Accessed: 21 July 2016]
- o Kostof, S. 1991. *The City Shaped: Urban Patterns and Meanings through History*, New York: Bulfinch Press.
- o Kotze, P. 2014. Taxi Rank No 2, Diepsloot, Johannesburg. Available at: <http://www.artefacts.co.za/main/Buildings/bldgframes.php?bldgid=12046> > [Accessed: 25 April 2016].
- o Lintula, S. 2006. Urban space (Florence) [jpeg]. <https://en.wikipedia.org>. Available from: https://upload.wikimedia.org/wikipedia/commons/6/6f/Piazza_della_Signoria.jpg. [Accessed: 1 September 2016].

- o Lloyd, R. 2003. Defining spatial concepts toward an African urban system. *Urban Design International*, 8, 105-117.
- o Local Studio. 2015. IMG_0153 [jpeg]. www.localstudio.co.za. Available from: <http://www.localstudio.co.za/new-blog/2015/10/1/outreach-foundation-community-centre>. [Accessed: 21 July 2017].
- o Local Studio. 2015. LCOF+SCAN [jpeg]. www.localstudio.co.za. Available from: <http://www.localstudio.co.za/new-blog/2015/10/1/outreach-foundation-community-centre>. [Accessed: 21 July 2017]
- o LOCAL STUDIO. 2015. Outreach Foundation Community Centre. Available at: <http://www.localstudio.co.za/new-blog/2015/10/1/outreach-foundation-community-centre> > [Accessed: 21 July 2016].
- o Lynch, K. 1981. *Good City Form*. Cambridge, Massachusetts: The MIT Press.
- o Mahlangu, S.L. & Wolmarans, P. 2016. Bophelo Precinct Development Plan.[n.p]
- o Mahlangu, S.L., Wolmarans, P., Rukambe, V. & Gowar, M. 2016. Mamelodi Urban Framework. [n.p]
- o New Zealand Social Infrastructure Fund. [n.d]. What is Social Infrastructure? Available from: <http://www.nzsif.co.nz/Social-Infrastructure/What-is-Social-Infrastructure/> [Accessed: 6 March 2016]
- o Parr,D. 2012. Biomimicry Lessons for Building Ventilation, Submitted for qualification of Environmental Design of Buildings MSc, at Cardiff University – Welsh School of Architecture.
- o Shankbone, D. 2008. Tract housing in Colorado Springs, Colorado [jpeg]. <https://en.wikipedia.org> . Available from: https://upload.wikimedia.org/wikipedia/commons/thumb/3/37/Suburbia_by_David_Shankbone.jpg/800px-Suburbia_by_David_Shankbone.jpg [Accessed: 1 September 2016].
- o Steyn, G. 2005. Patterns for people-friendly neighbourhoods in Mamelodi, South Africa. Paper presented at the World Congress on Housing, Transforming Housing Environments through Design, September 27-30, Pretoria, South Africa: 1- 6
- o Steyn, G. 2008. Current trends in South African architecture and the way to the future. *SAJAH*, 24(2), 41-64.
- o Steyn, G. 2008. Market streets in South Africa’s informal settlements. *SAJAH*, 23(1), 175-189.
- o Sustainabilityworkshop.autodesk.com. (n.d.). Stack Ventilation and Bernoulli's Principle | Sustainability Workshop. [Sustainabilityworkshop.autodesk.com](http://sustainabilityworkshop.autodesk.com/buildings/stack-ventilation-and-bernoullis-principle). Available from: <http://sustainabilityworkshop.autodesk.com/buildings/stack-ventilation-and-bernoullis-principle> > [Accessed 10 Oct. 2016].
- o Thomas. 2013. Azuchi [jpeg]. Japan Reference. Available from: <http://www.jref.com/media/azuchi.3491/>. [Accessed: 22 July 2016]
- o UN-Habitat. 2003. *The challenge of slums: global report on human settlements 2003 / United Nations Human Settlements Programme*. London and Sterling, VA: Earthscan Publications Ltd.
- o Wehner, J. 2000. Development Strategies in Post-Apartheid South Africa. *Africa Spectrum*, 35(2), 189-192.

DECLARATION

In accordance with Regulation 4(e) of the General Regulations (G.57) for dissertations and theses, I declare that this thesis, which I hereby submit for the degree Master of Architecture (Professional) at the University of Pretoria, is my own work and has not previously been submitted by me for a degree at this or any other tertiary institution.

I further state that no part of my thesis has already been, or is currently being, submitted for any such degree, diploma or other qualification.

I further declare that this thesis is substantially my own work. Where reference is made to the works of others, the extent to which that work has been used is indicated and fully acknowledged in the text and list of references.

Siyabonga Lunga Mahlangu

December 2016