

8 TECHNICAL INVESTIGATION

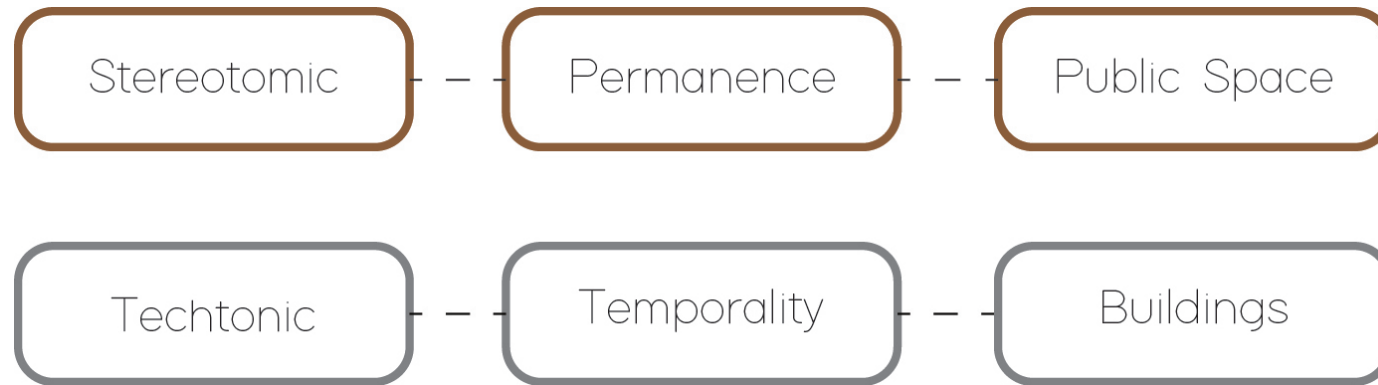

Figure 128:Tectonic concept. (Author 2016)

8.1 TECTONIC CONCEPT

The immediate context of the project is defined by a duality. There is a continuous influx of people traversing the state of permanence and temporality. The intention is to create an architecture that allows the public spaces to be defined with very limited choices of change and also an architecture that will allow for changes related to the changing needs of the growing community. The **public realm** will be defined as the most important component of the project and the community, as such, will be permanent. The buildings within the intervention will engage with the idea of temporality and as such become the ever changing background to the public realm.

8.2 TECHNOLOGICAL INTENTION

An investigation of the materials mostly used in the context led to the concept of engaging with the idea of permanence and temporality. The public realm and its platform will use stereotomic elements and materials such as concrete and masonry. The buildings will be tectonic, allowing for easier adapting of the building and increased visual and physical transparency.

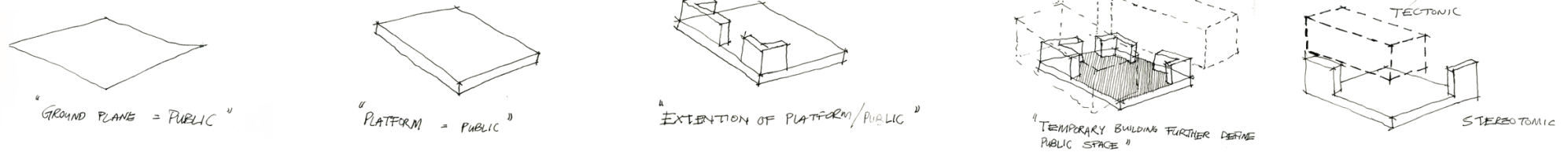

Figure 129: The platform and the process the building begins to grow from it (Author 2016).

8.3 STRUCTURAL INTENTION

The **platforms**, the podiums which form the primary structure of the buildings, which define the public space, will use masonry a material normally used in the vertical plane. The service core of the buildings will also be stereotomic and function as a structural component to the building and also as a structure through which adaptations may occur. The buildings will use steel and light gauge steel structures to reveal the makings of the building (material honesty) transparency and allow for adapting of the building. This will be based on 3x3 metre grid.



Figure 130: The RDP house and the shack, and the materials [Lusaka, Mamelodi] (Author 2016).

8.4 LEARNING FROM THE CONTEXT

Understanding the temporality and permanence duality in Lusaka becomes paramount. It goes beyond understanding the social consequences of this duality and towards the technological consequences. There are two main building types, namely the RDP house and the shack.

The RDP dwelling being made up of masonry units symbolise permanence. This same material is taken further

and used to building even larger homes. The traditional shack is made up of a timber frame made from timber pallets and clad with steel sheeting. This building method is considered as a cheap and temporary way of building a house. The basic shack can be adapted to a growing family or for greater spatial needs. Building technologies from these two typologies are incorporated in the project.

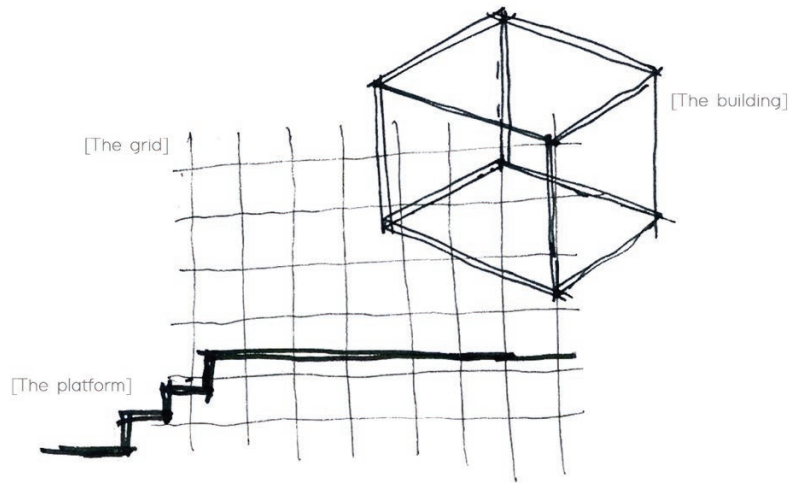

Figure 132: The relationship between the platform, the grid and the building. Tectonic concept (Author 2016).

The platform, which defines the public spaces, will be made of and use masonry and concrete. The intention is to recognise the public space as being permanent and therefore defining with a material symbolising permanence. The building will have a temporary aspect by allowing adaptable elements within the structural framework of the building.

The following architectural elements and their relationship will be investigated: The platform, the building and the grid. The grid becomes an important element as it functions on two levels:

The grid creates a dialogue between the building and the landscape. This is done by utilising the same grid size of 3x3 meter and using it to control space. The grid size remains constant to create a link between the landscape, the building and its components. This grid on two axes (figure 120) the first axis is for the market and recreational space. The second axis is for the communal space. The public spaces and relative buildings respond to these axes.

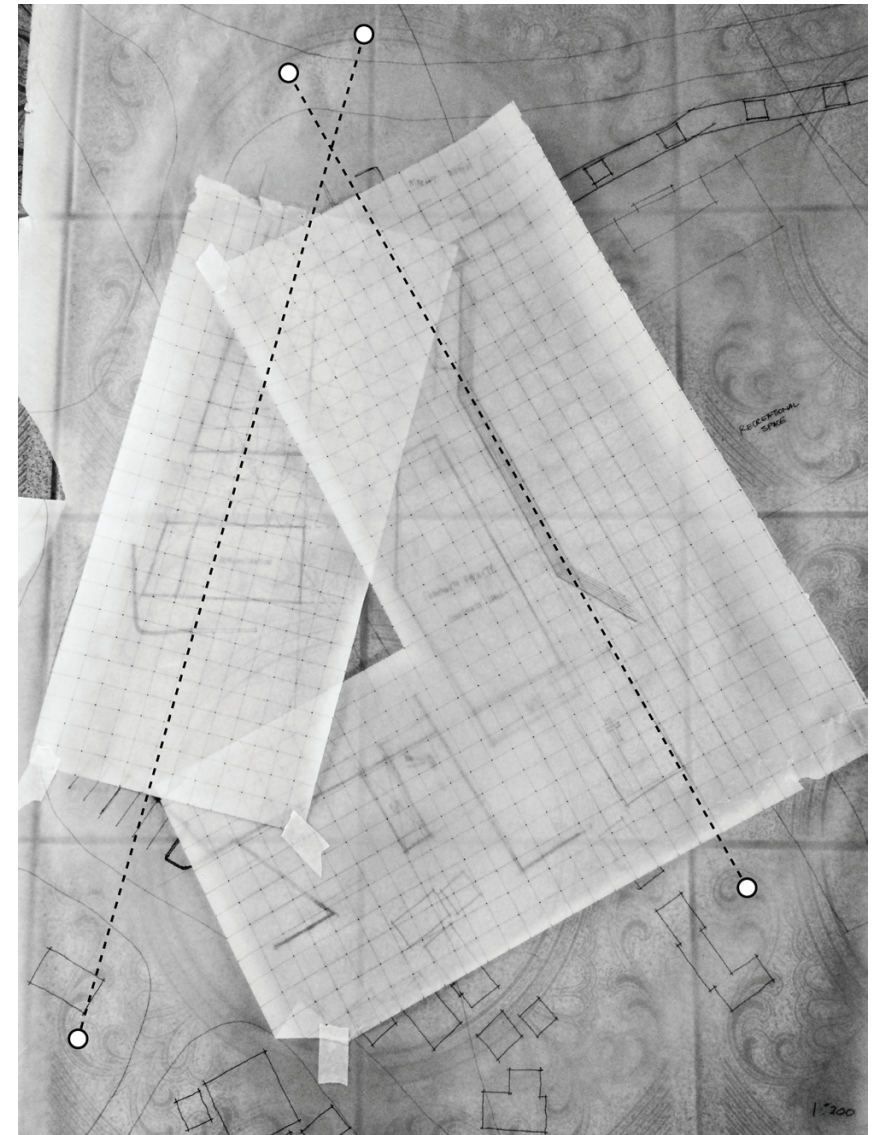

Figure 131: Grid and Axes the building layout and structure are based (Author 2016).



[Alternative energy generation]

8.5 SERVICES AND SUSTAINABILITY

Alternative ways of producing electricity are employed in the building. The cell module will be extracted from a traditional solar PV panel and be used to create an architectural element that creates a threshold between the building and the landscape; and an element that produces electrical energy that is to be used in the building.

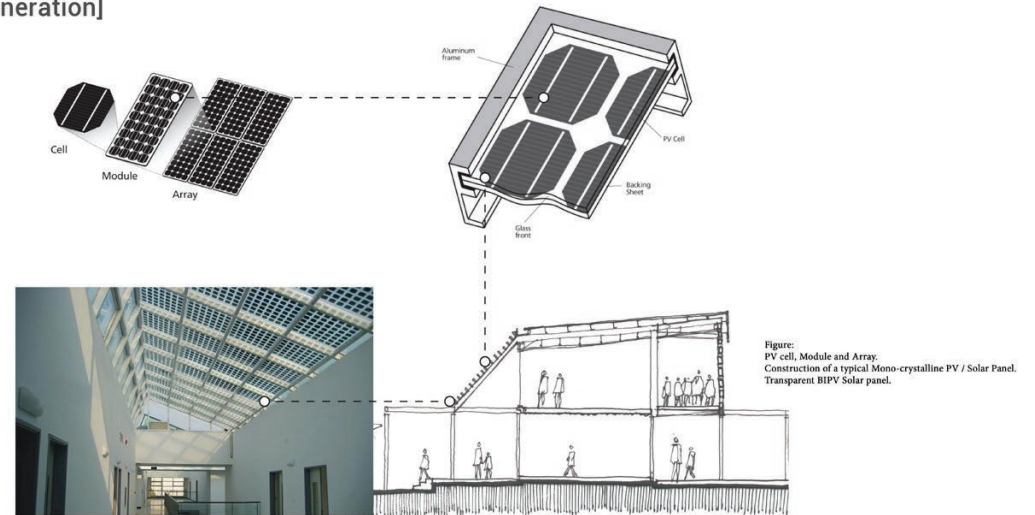

Figure:
PV cell, Module and Array.
Construction of a typical Mono-crystalline PV / Solar Panel.
Transparent BIPV Solar panel.

Figure 133:Reimagining the solar panel (Adapted by Author 2016).

[Water + Heating and Cooling]

With the large surfaces from the roofs, 500 square meters and the platforms, water will be collected and stored underneath the platform. This water will be used as grey water for the ablutions as well as for irrigation. The platform performs another function. Geothermal pipes are routed under the platform and are used to heat and cool the building.

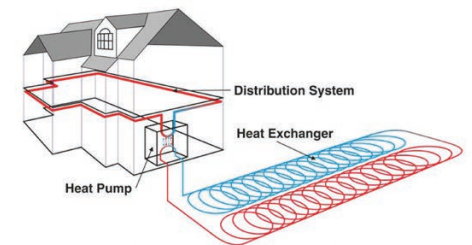
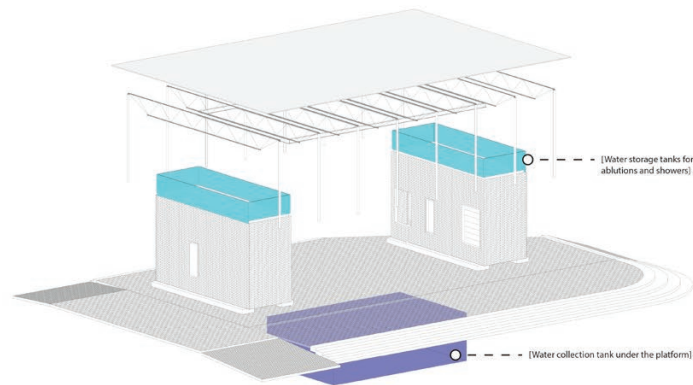

Figure: Ground-source heat pumps require three elements: heat exchanger, heat pump and distribution system.

Figure 134: Water cooling + heating and cooling strategy (Adapted by Author 2016).

Technical precedent

Stack ventilation uses the difference in air temperature to move air. It works from the principle that hot air rises because of its lower pressure. As it rises, it sucks in colder air, bring fresh air into the room (Sustainabilityworkshop.autodesk.com n.d.). The stack effect used in conjunction with a solar chimney which uses the sun as energy source to heat up the air in the

chimney which is then exhausted out of the chimney thereby sucking in cold air at the bottom. This strategy is similar to the one used in the Eastgate Building in Harare, designed by Mick Pearce. It uses solar chimney that ventilate the office spaces and the atria (Doan 2012).

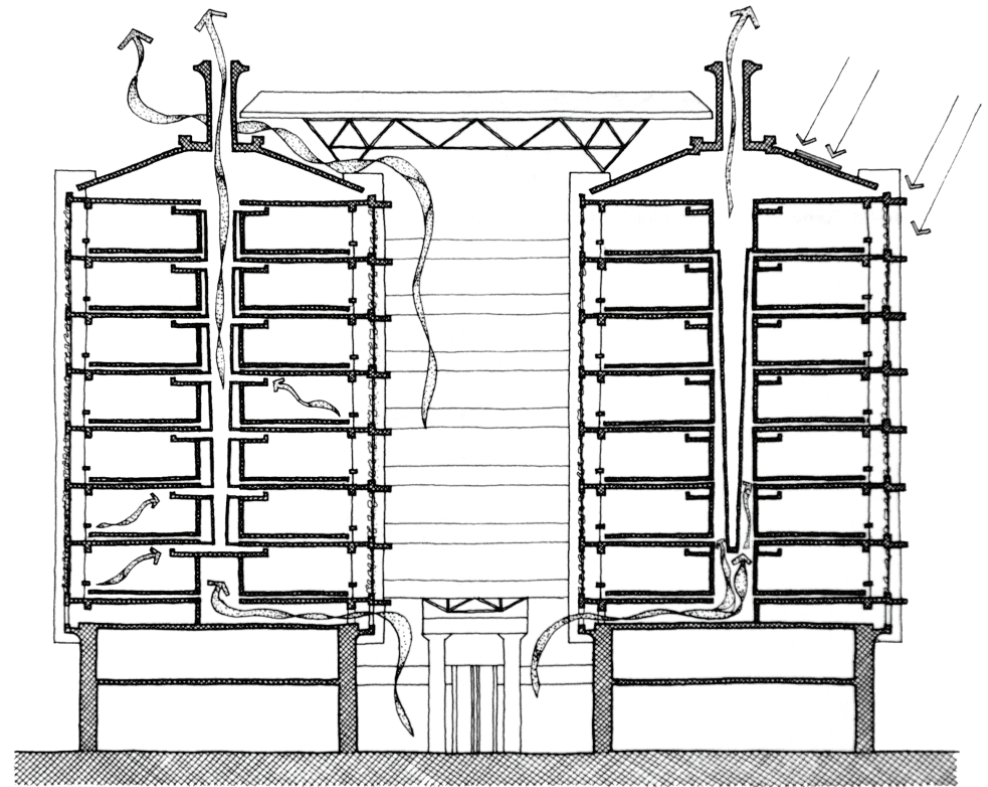

Figure 135: Section of the Eastgate building illustrating the movement of air through the building due to the passive ventilation strategy used (Sustainabilityworkshop.autodesk.com n.d.)

[Ventilation]

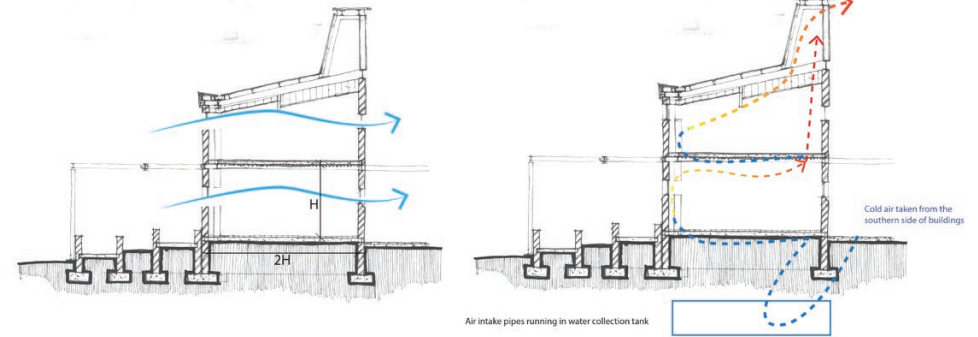

Figure 136: Illustration of ventilation strategies used in the building (Author 2016).

Natural ventilation is possible in all building on the site as the buildings proportions are within the prescribed limit of $h / 2h$, with 'h' being the height from floor to ceiling, will allow for natural wind to exhaust the building of hot air. Alternatively, the water collected under will also be used to drive the passive ventilation system. Cool air will be pulled from the southern side of each building. The pipe that collect the air will be

routed inside the water collection tanks to help further cool the air in the pipes. The air is then injected in the buildings, on all levels, and is exhausted through the service core of each building.

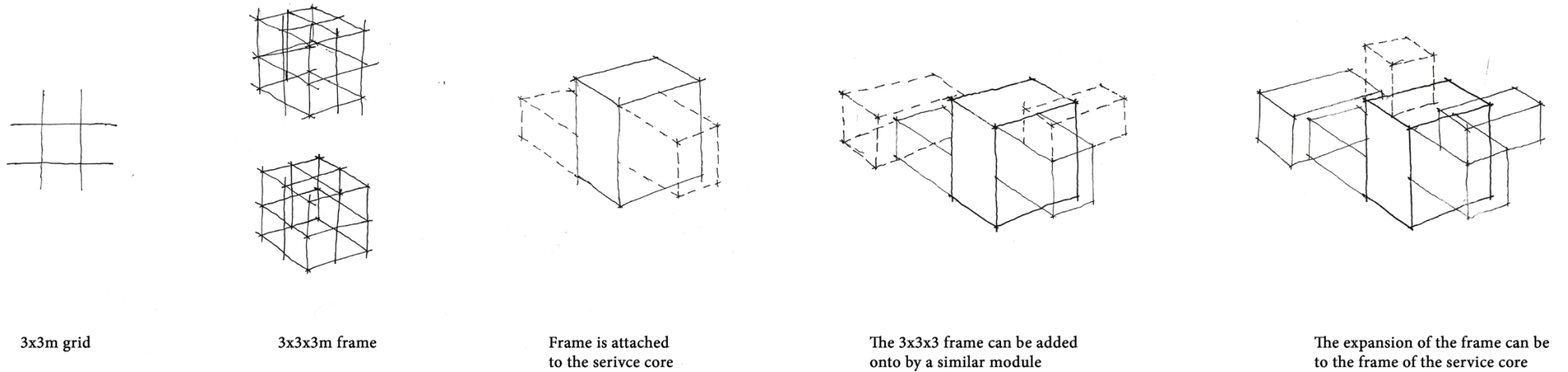

Figure 137: The formation of the grid and how changes can be implemented through it (Author 2016).

8.6 THE STRUCTURE

The grid becomes a three dimensional element which organises and structures the different parts of the building. The grid becomes the primary structure on which the buildings are based upon as shown in figure 122. The modular 3x3 grid is the made into a 3x3x3 frame the buildings are based on. The modular frame will allow for the ability to adapt the

building in the future when the spatial requirements change. The grid could become a universal principle that is used for various building typologies and in this case, it could be used for both the civic proposal of the project and the residential component (small network hubs).

[The GRID]

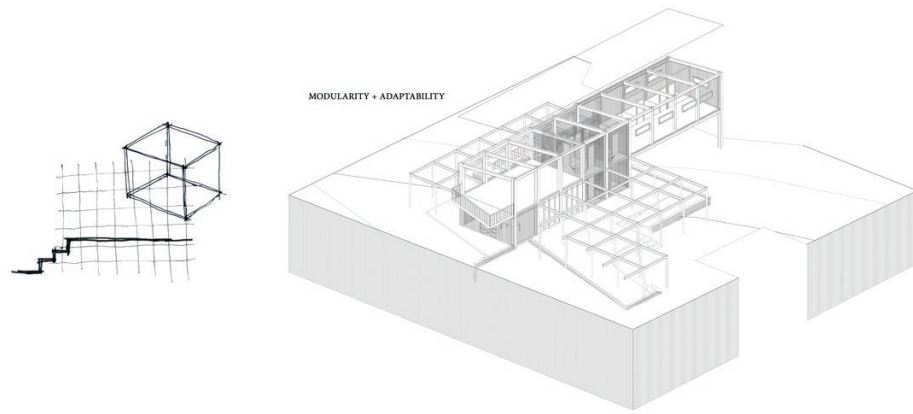

Figure 138: The grid and how it is used to create a building and a link to the landscape (Author 2016).

When one unpacks the architectural technology of the shack, two elements are used:

- A frame
- Cladding

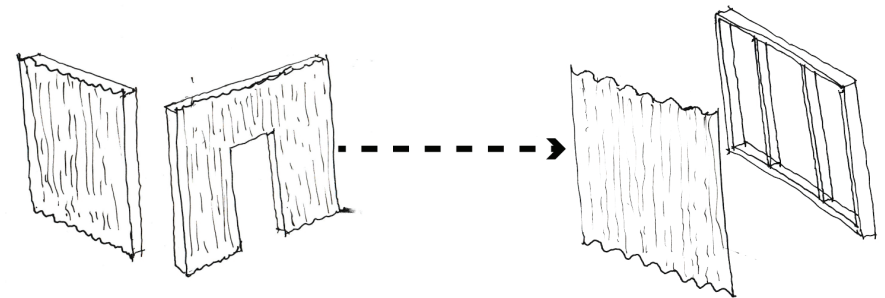
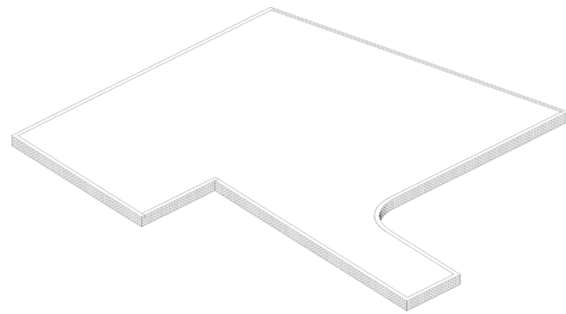

Figure 139: Exploded view of a shack panel. The shack panel elements are reinterpreted to create a new architectural language (Author 2016).

These elements are reinterpreted as:

- The grid
- The panel.

These are elements used to construct the architecture. They reuse familiar building elements in a way that uplifts the existing architectural language in the context.



The platform (podium) that is the base of the building as well as the initial definer of the public space.

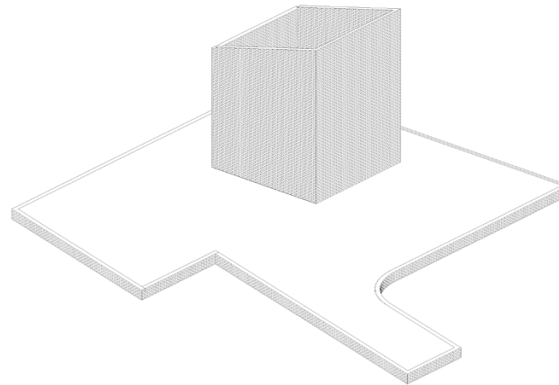

The service core is then built on the platform. These two elements are stereotomic and are built with masonry and form part of the buildings primary structure

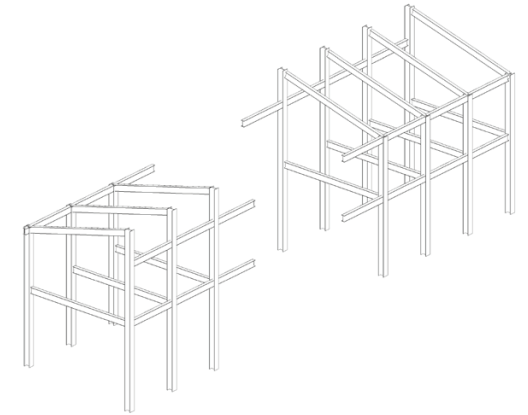

The 3x3 meter grid becomes the basis for the buildings secondary structure

Figure 140: The construction and adaptation of the building (Author 2016).

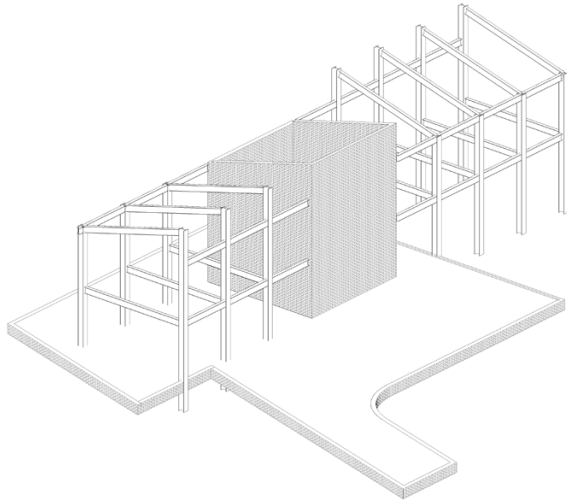

The steel frame are then attached to the platform and the service core, linking the primary and secondary structural elements.

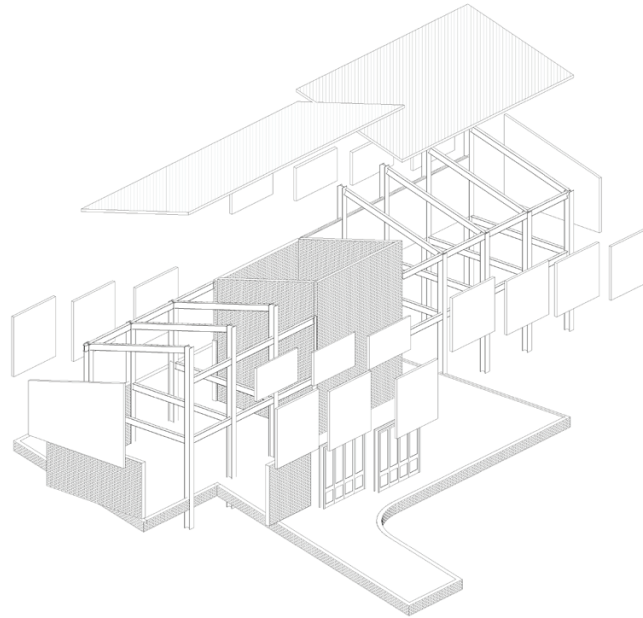

Prefabricated wall, roof and floor panels will then infill the steel frame. The type of panel will depend on the orientation of the wall panel and the internal function / activity that is enclosing.

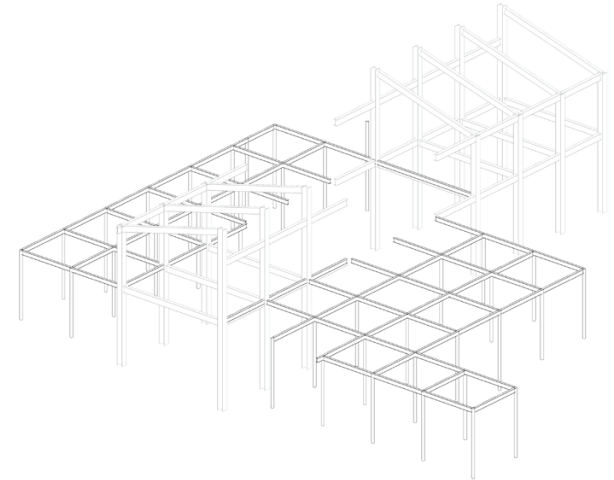

The steel frame can be adapted with a frame using the same 3x3 metre grid. The grid becomes the element that will link the landscape and building.

8.7 THE PANEL

The panel becomes an integral element. It becomes the infill of grid and an element that adds to the architectural language of the building. The panel is a familiar architectural element that is then reinterpreted and given more meaning. The panel will take different forms depending in the function of the space inside, it is orientation to the sun and the level of privacy needed. The panel can be a static element; as a wall / roof panel or a dynamic element such as a door or a movable interior panel.

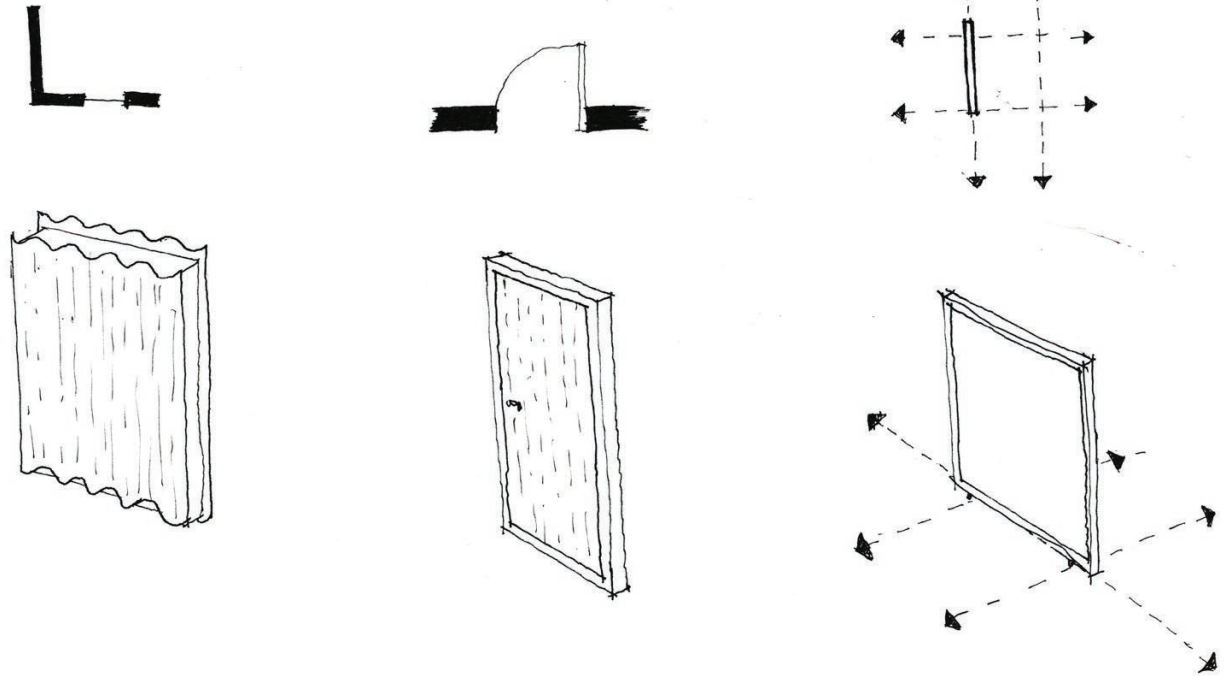
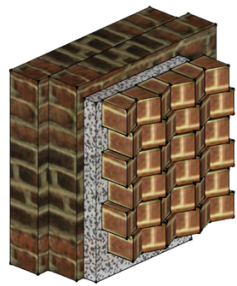
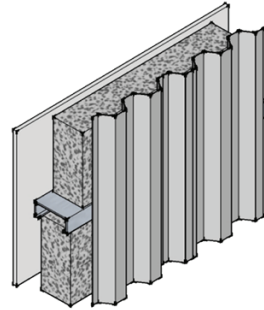

Figure 141: The panel in the various forms. (Author 2016)

[The PANEL]



[Brick infill]
East and west orientated walls
Service cores



[Light gauge steel]
North orientated walls
Service rooms
Office spaces

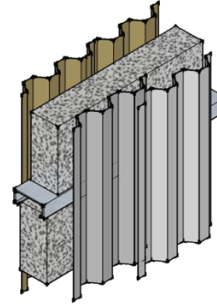

[Light gauge steel]
North / South orientated walls
Office spaces

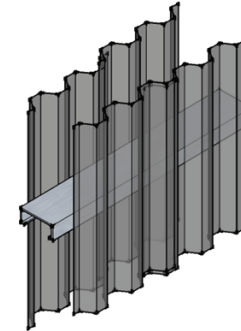

[Light gauge steel]
South orientated walls
Circulation spaces

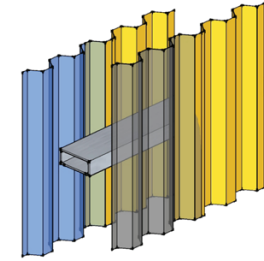

[Aluminium]
Sliding door panels

Figure 142: Variations of the panel (Author 2016).

The panel will be a locally manufactured item. The panel structure will have two structures:

- SA pine structure
- Light gauge steel

The choice between the two depends on the structural needs and the financial constraints. Having a structure that is cheaper to produce allows for smaller projects to use the similar design principles and technology. This project will

use light gauge steel as the primary structure of the panel. This is to illustrate the option of this being a feasible building technology in this context. This may result in a new business venture that may be created.

Standard panel size fitting a 3x3 meter grid frame will be made off site and additional panels that can not fit the standard grid will be made on site. The panels will be created off site and then brought to site for installation. This creates a possible production network within Mamelodi, from raw material to final product. Petrus Wolmarans' dissertation on TVET colleges and their guilds will produce the panels.

THE PANEL - Infill panels which become the initial phase of the building.

8.7.1 The wall panel.

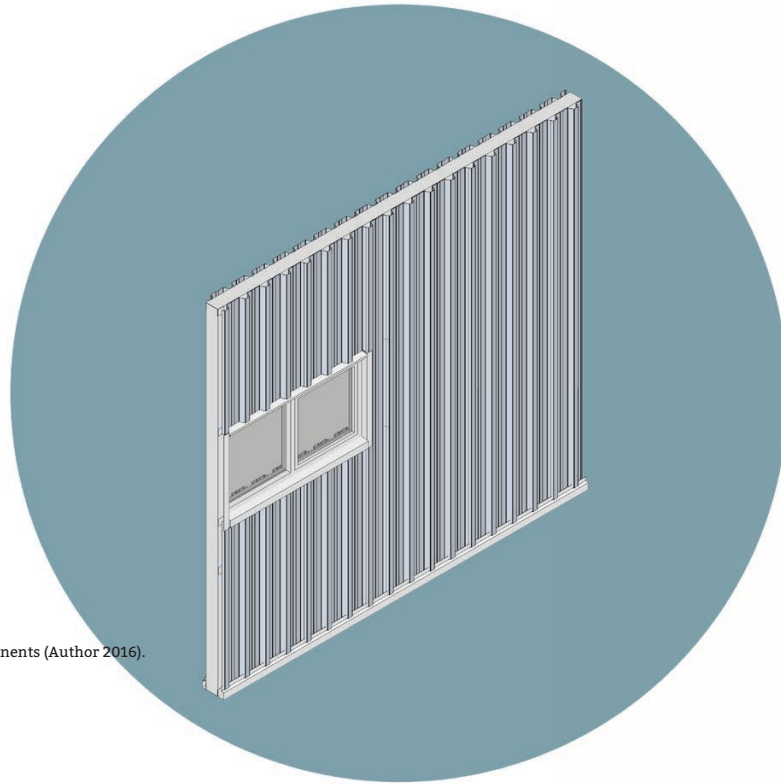
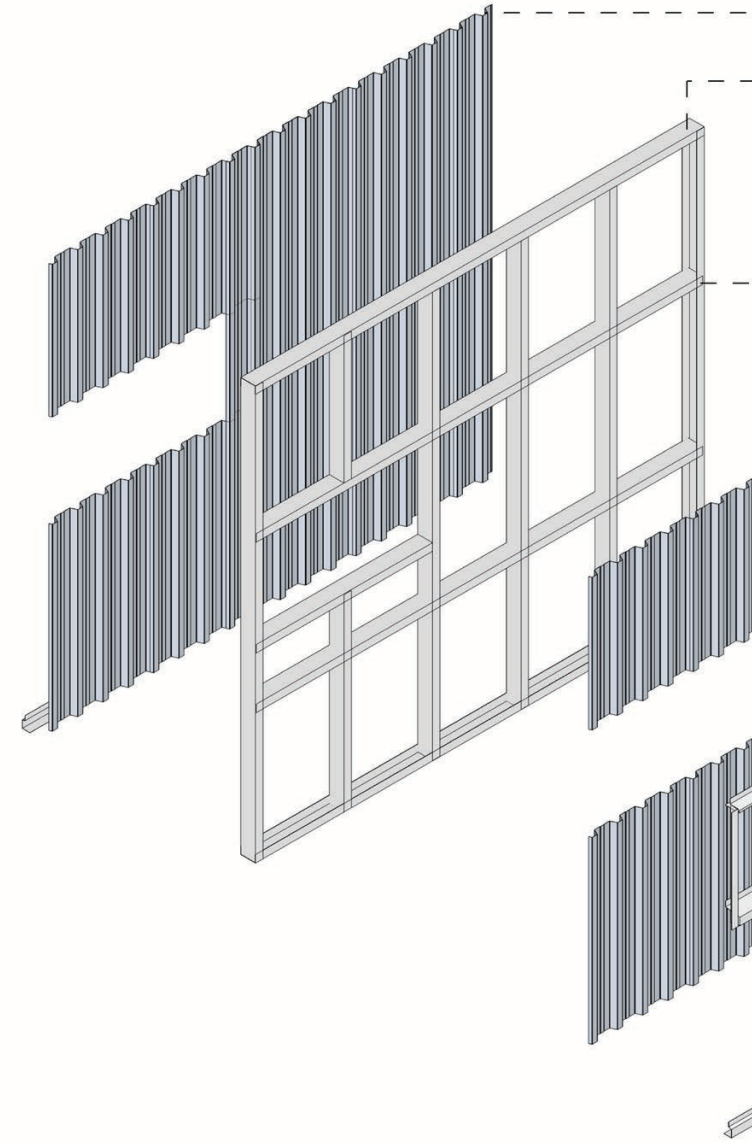

Figure 143: Basic corrugated steel wall panel and its components (Author 2016).



The Panel

The panels are designed to be a prefabricated panel system that is inserted into a frame. The panel system becomes the initial phase for the building. This is then followed by the addition of an attachment system.

0.58mm Chromadek IBR 686 steel sheeting screwed on to Zin-
calum light steel studs at 600mm centres

102mm Zincalum steel Top track

102mm Zincalum light steel studs placed at 1200mm centres

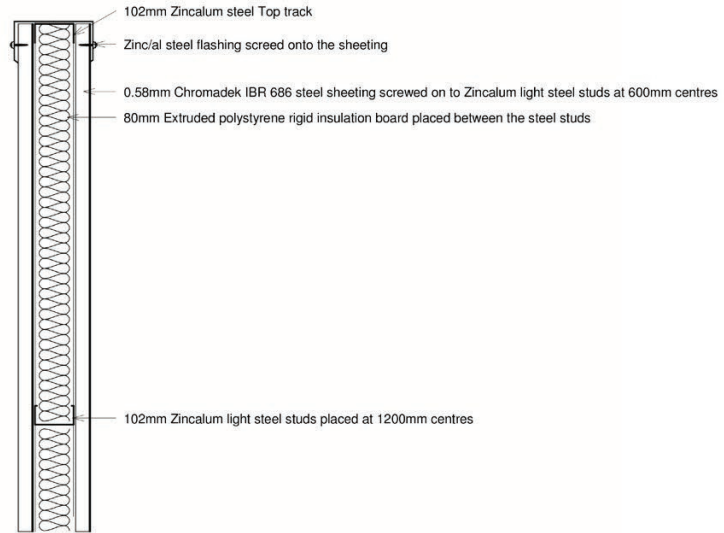
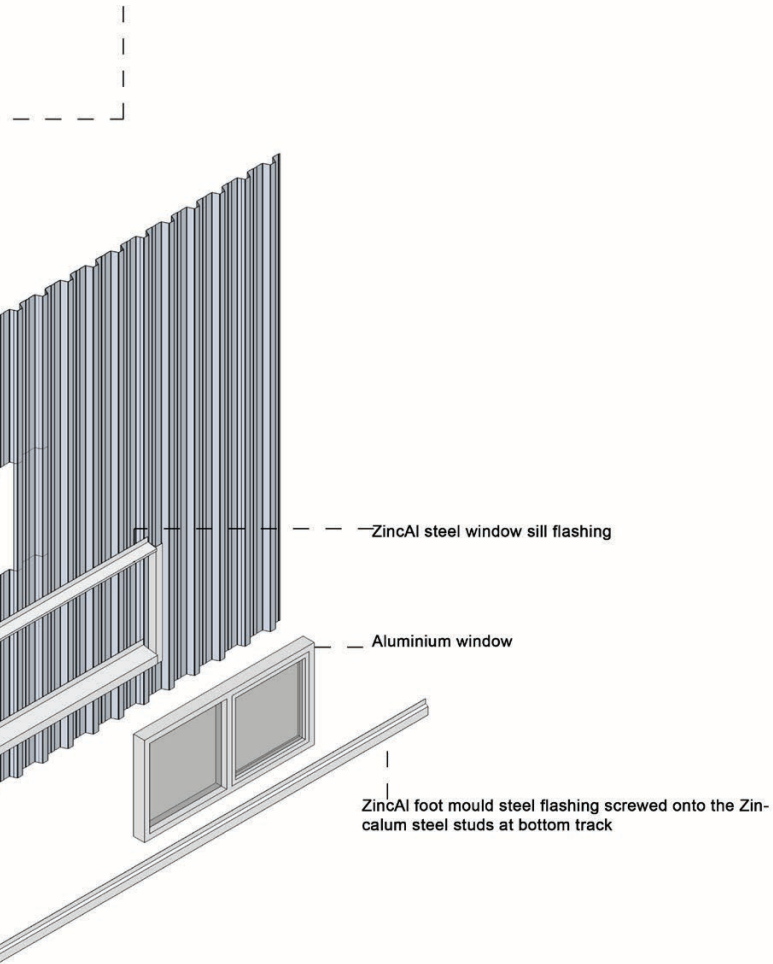

PANEL DETAIL TOP

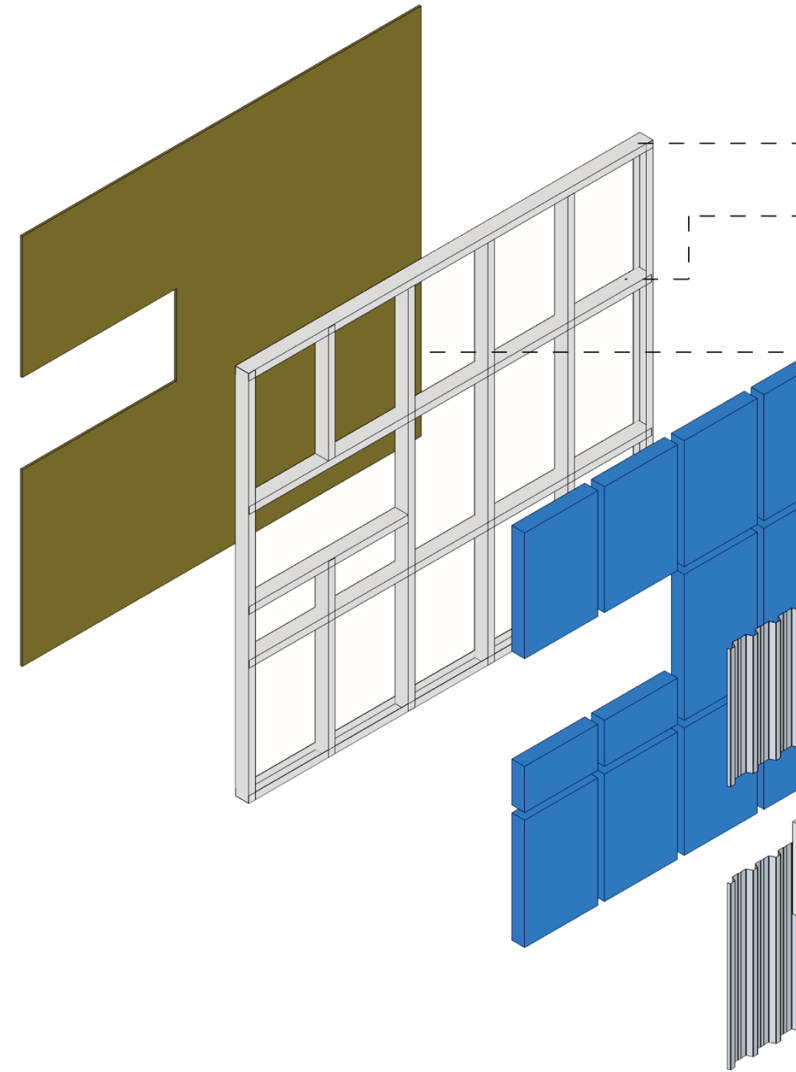
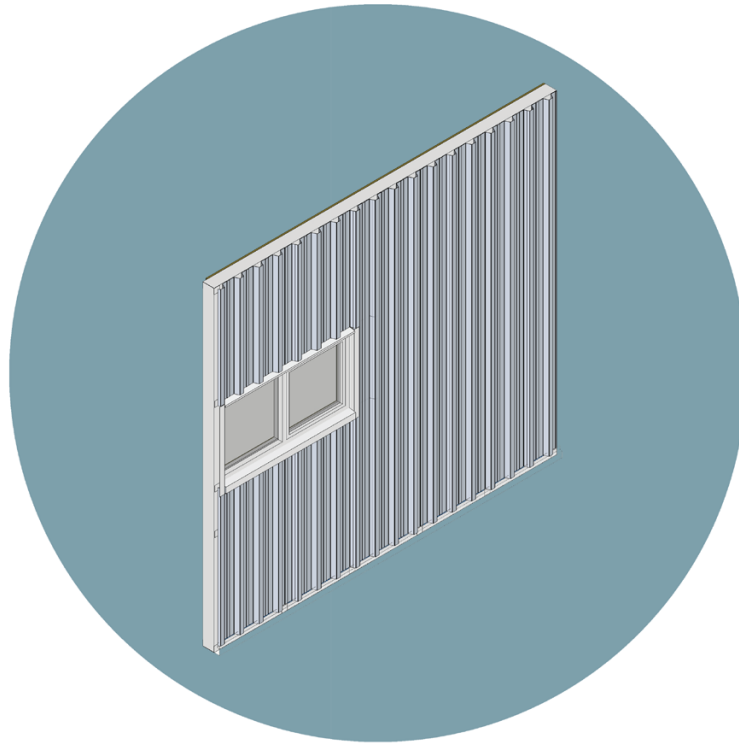
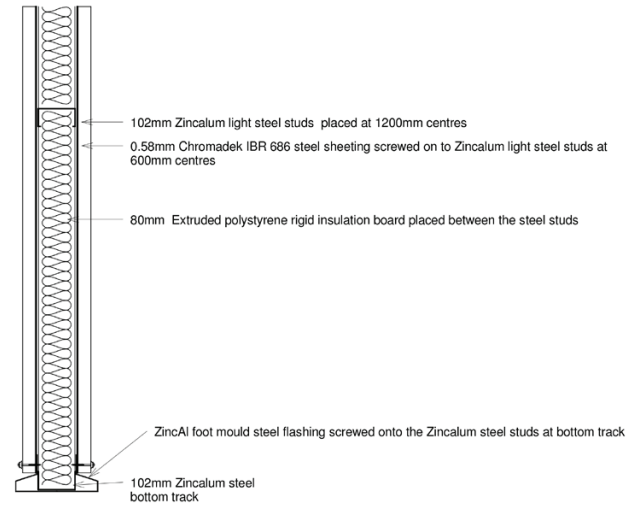
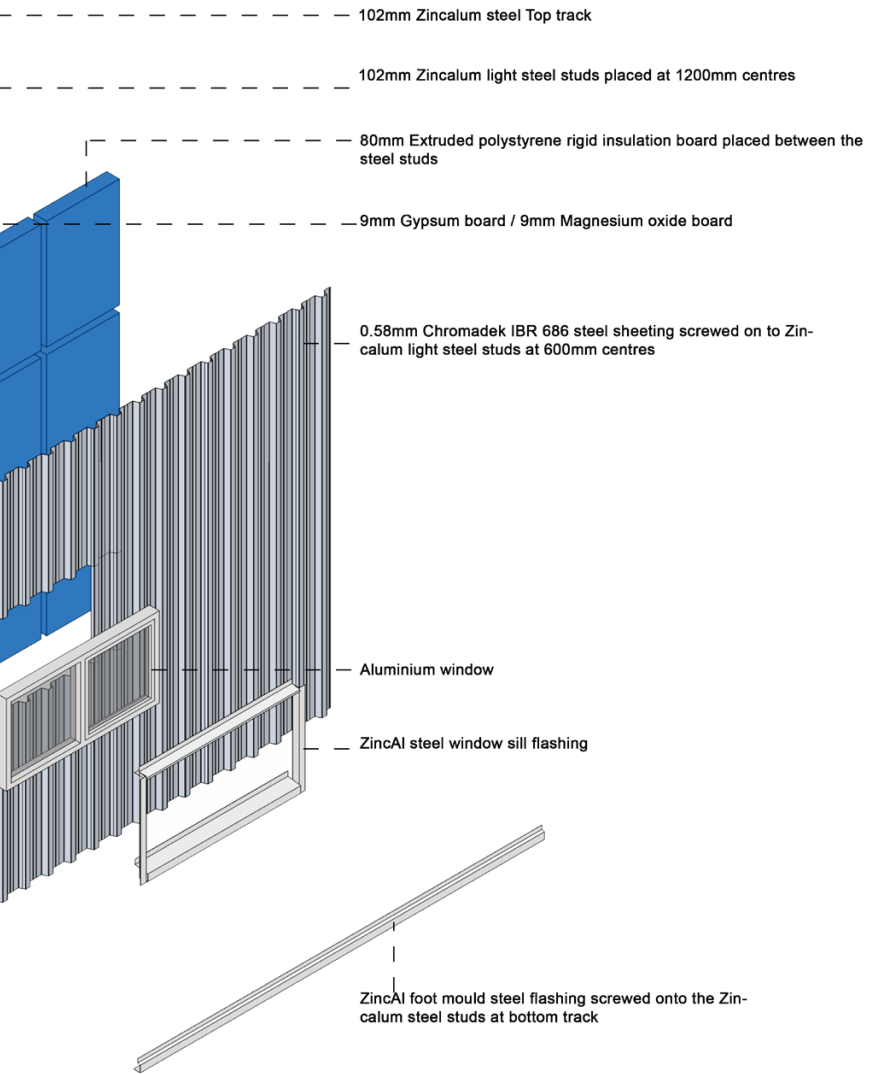

Figure 144: Wall panel. Corrugated steel and magnesium board or gypsum board as an interior finish (Author 2016).



PANEL DETAIL BOTTOM

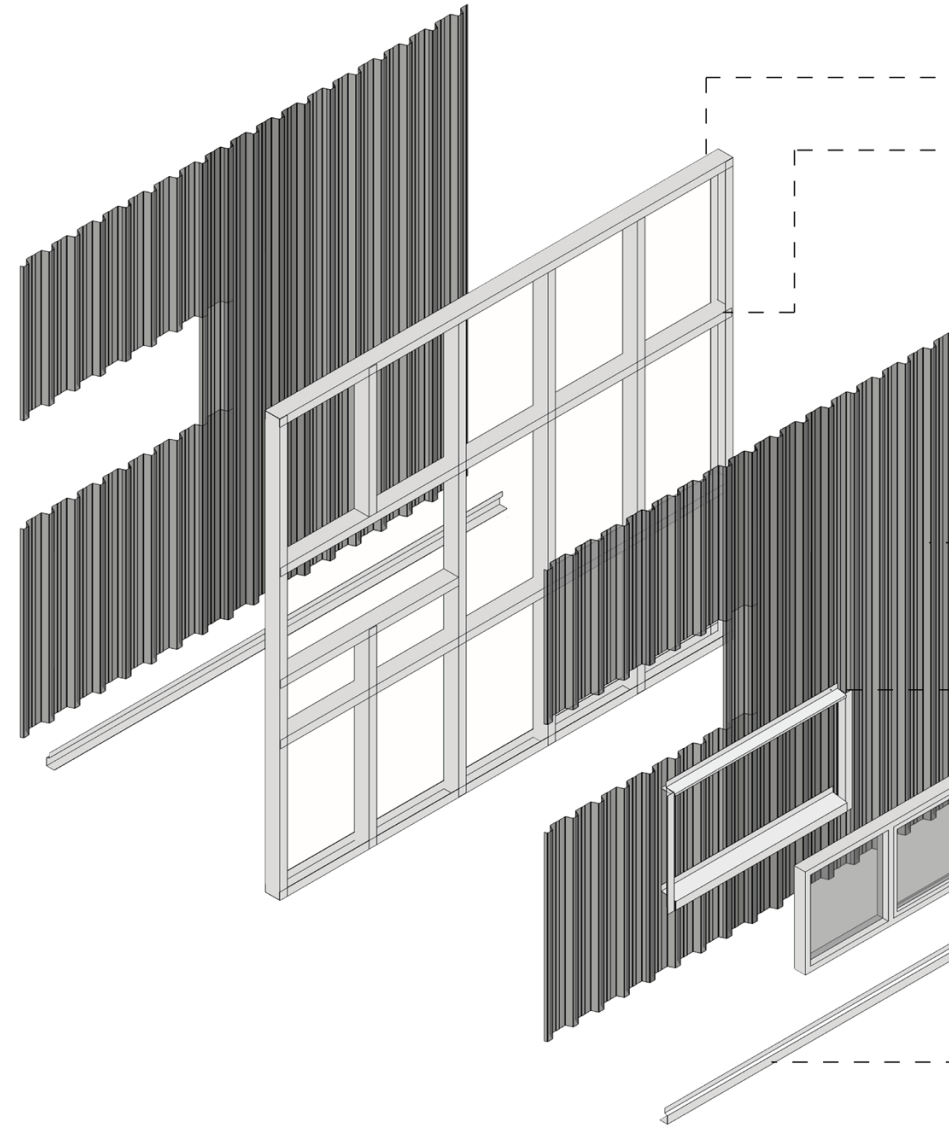
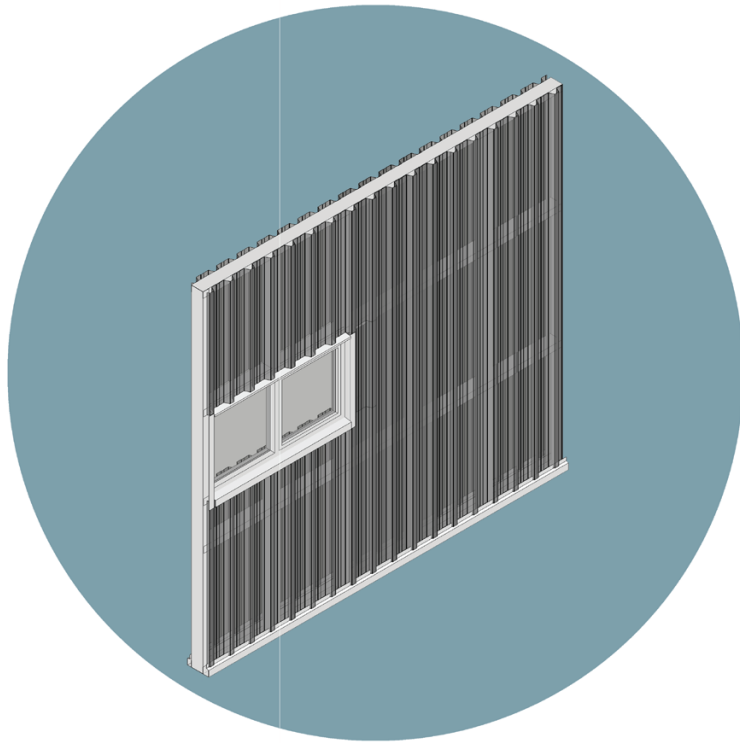
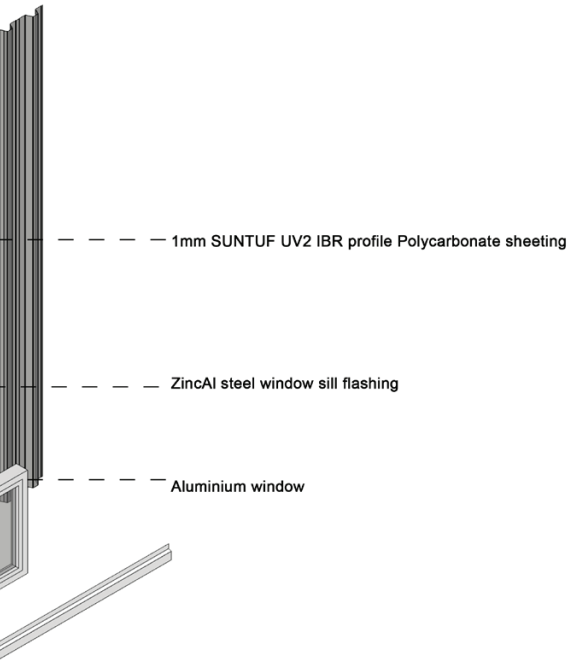
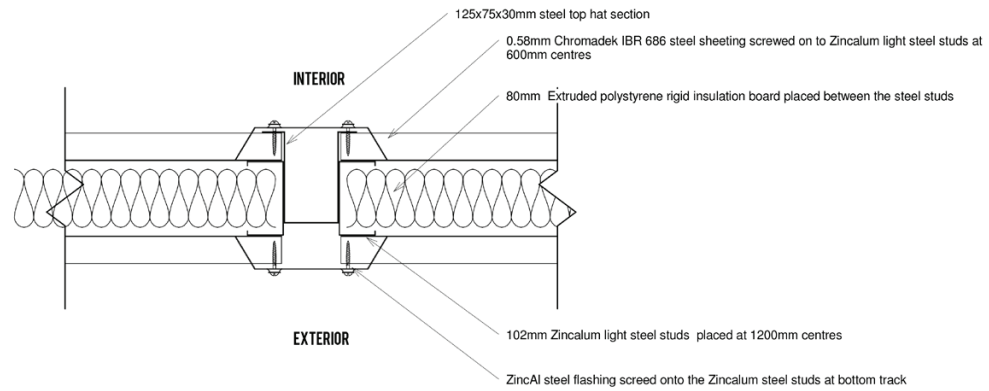

Figure 145: Wall panel. Polycarbonate sheeting with a UV layer placed on both the interior and exterior (Author 2016).

- 102mm Zincaluminium steel Top track
- 102mm Zincaluminium light steel studs placed at 1200mm centres



- ZincAl foot mould steel flashing screwed onto the Zincaluminium steel studs at bottom track



PANEL DETAIL JOINT

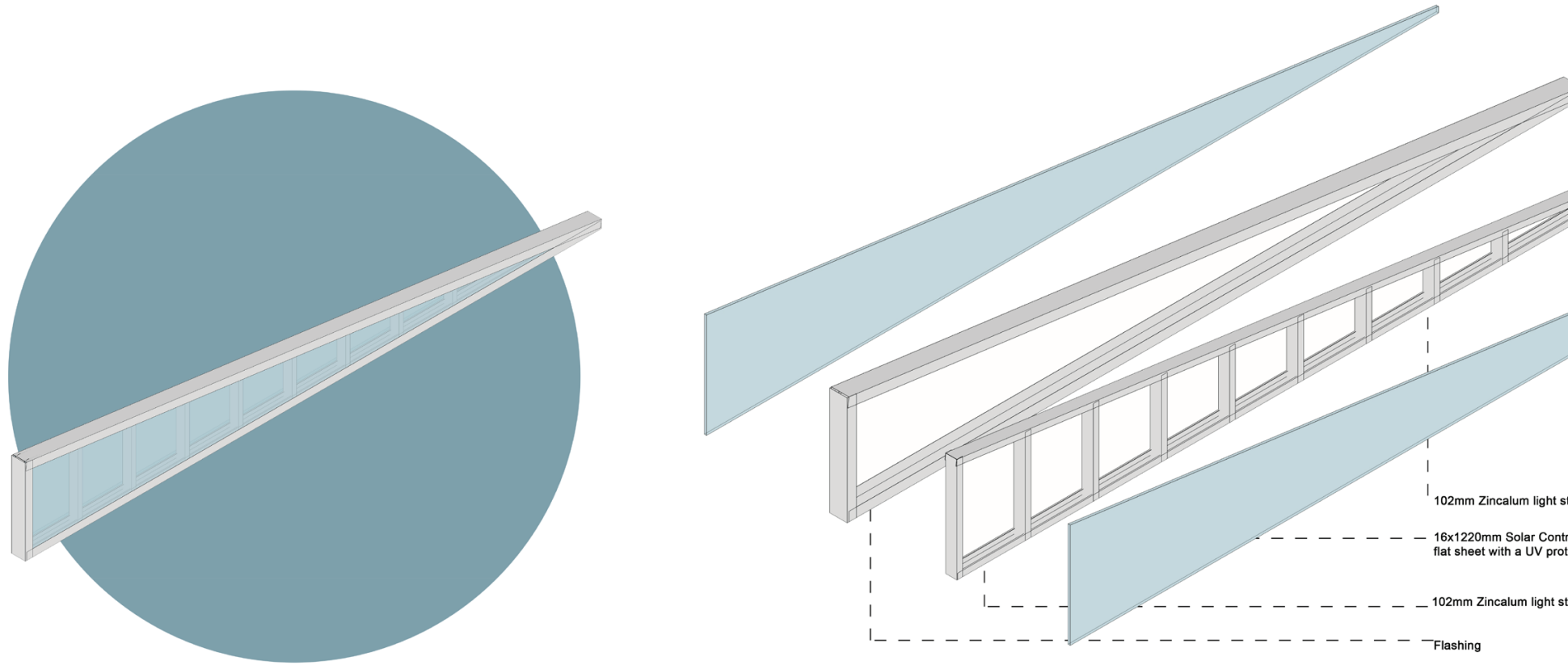
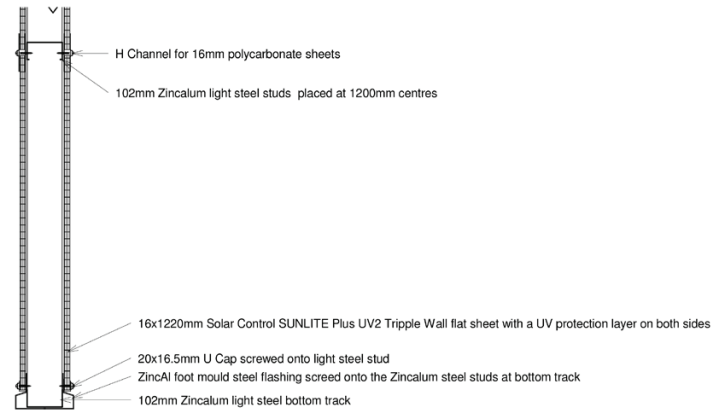
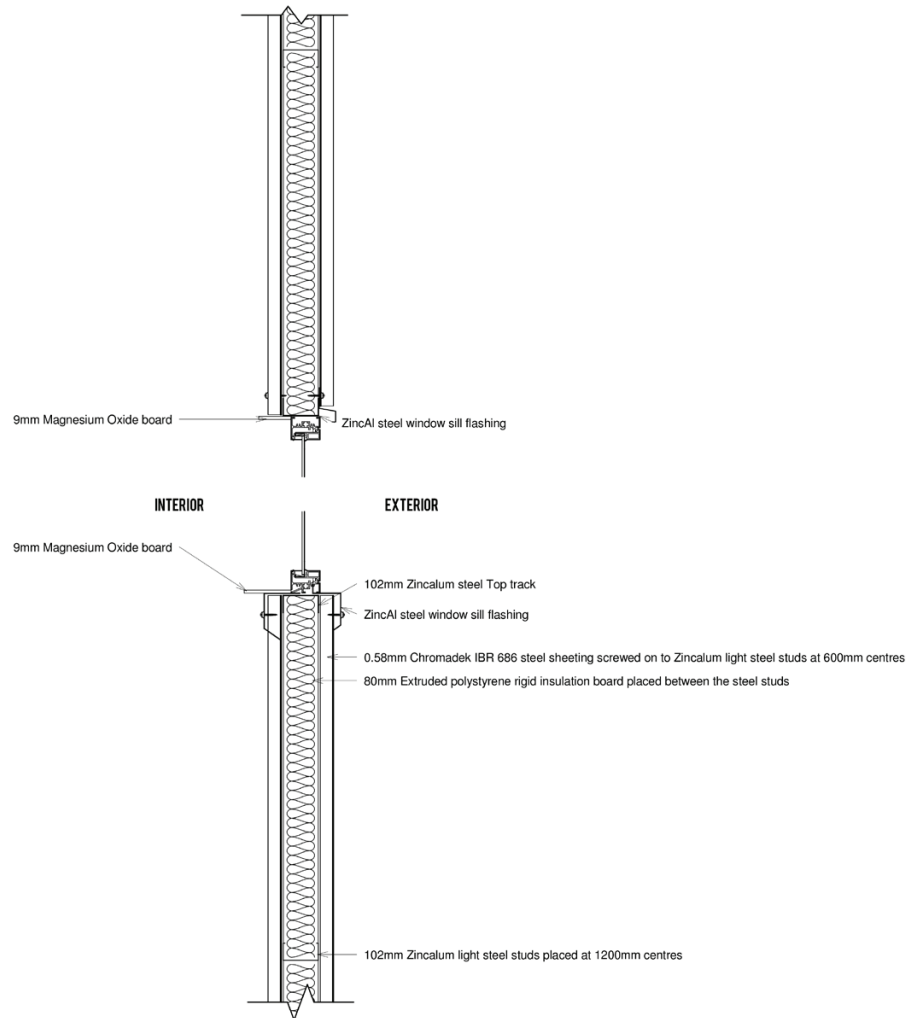

Figure 146: Wall panel. This is a custom wall panel. This item will be used for non-modular infill panels (Author 2016).



WINDOW DETAIL



TRANSLUENT PANEL BOTTOM DETAIL

8.7.2 The door panel

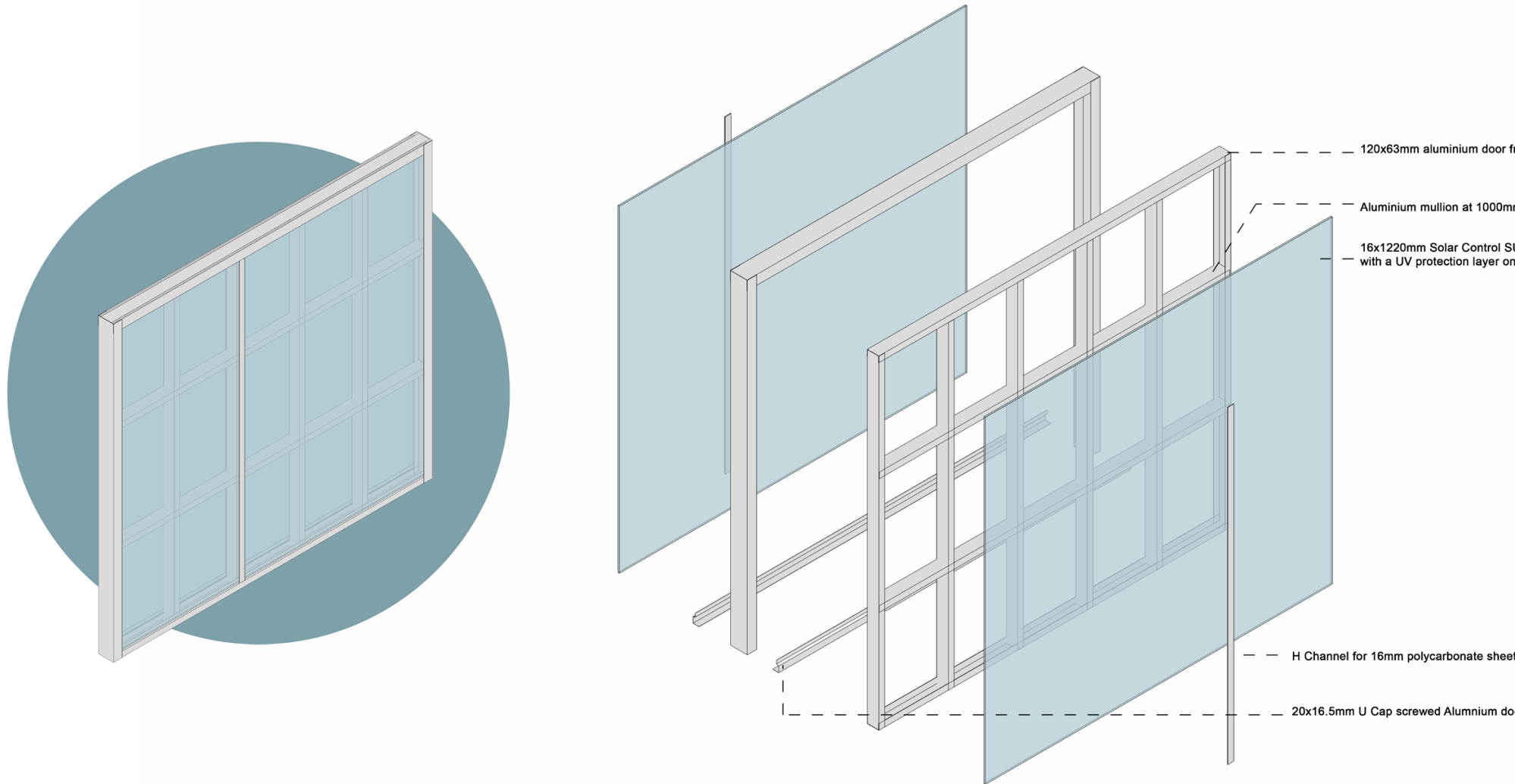
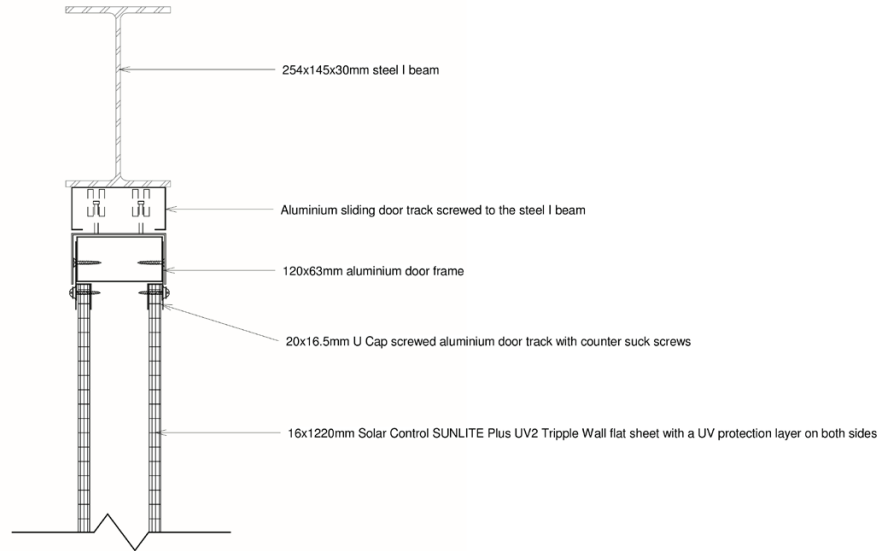

Figure 147: Sliding door panel. This sliding door is used in the administration building and the community hall (Author 2016).

frame

m centres

SUNLITE Plus UV2 Tripple Wall flat sheet
both sides



is screwed to aluminium mullion

or track with counter suck screws



SLIDING DOOR DETAIL TOP RAIL

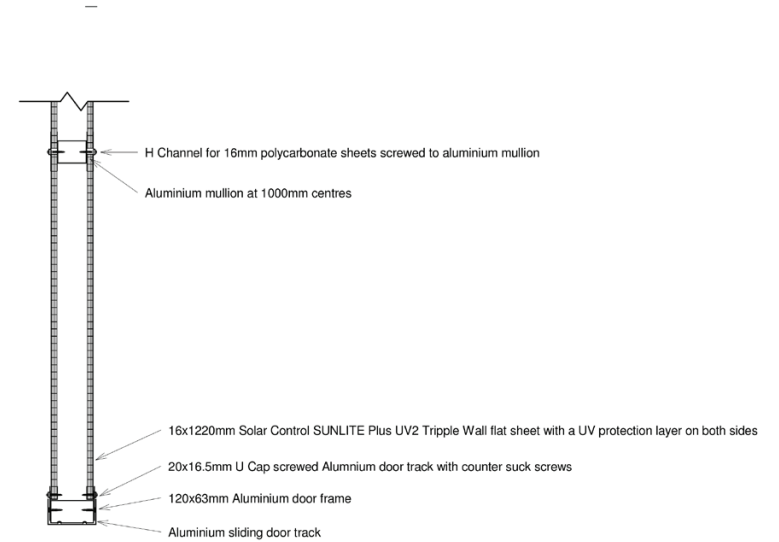

SLIDING DOOR DETAIL

8.7.3 The roof panel

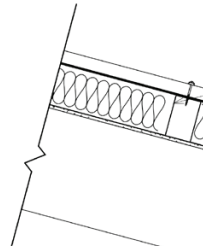
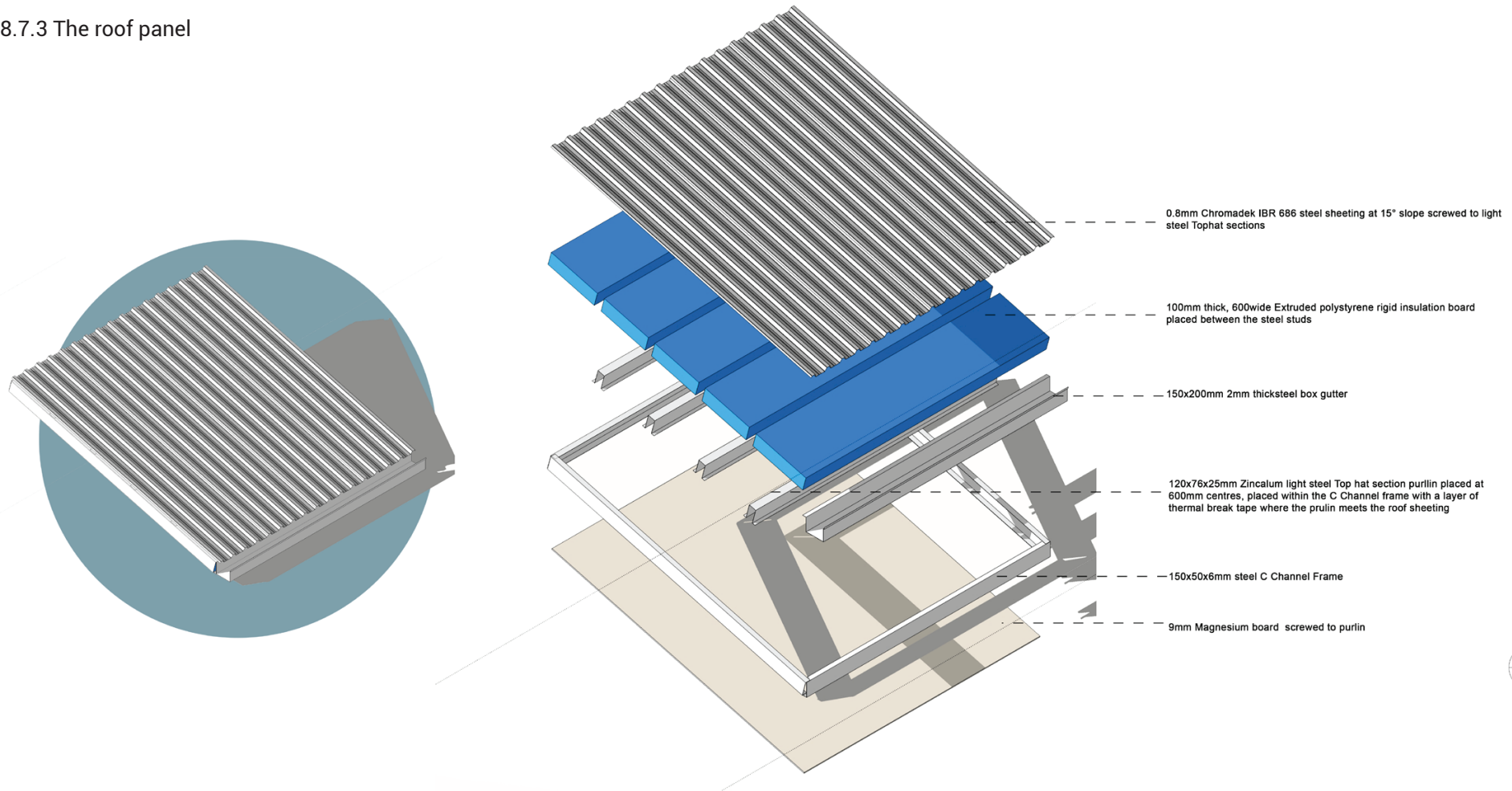

 **ROOF GUTTER**

Figure 148: Roof panel. The panel is a modular element (Author 2016).

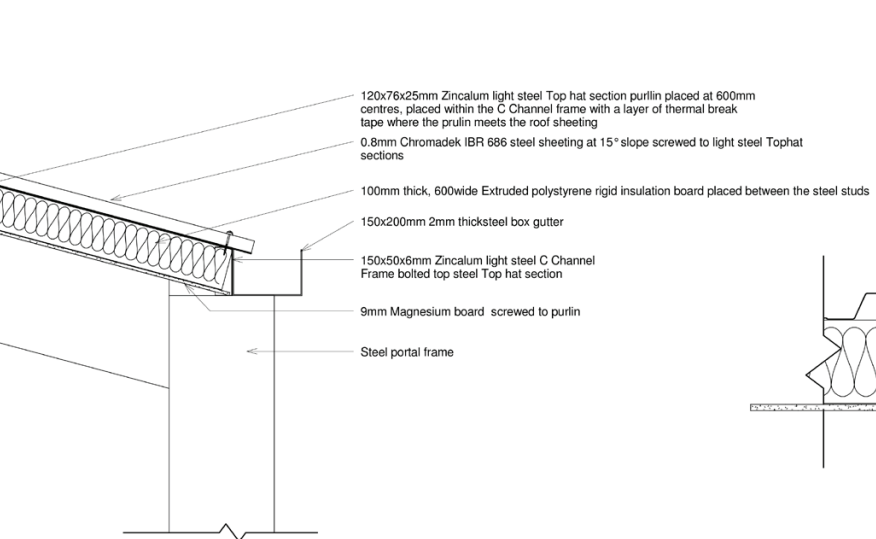

ROOF DETAIL

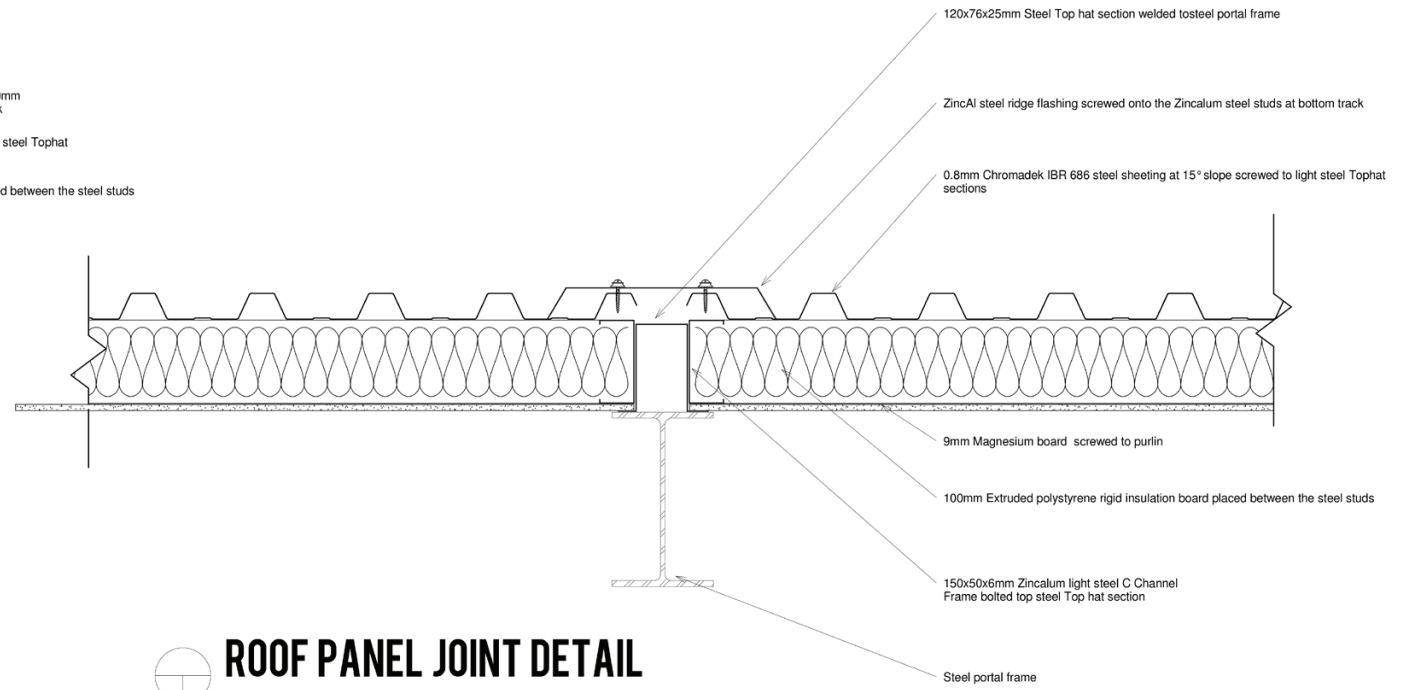

ROOF PANEL JOINT DETAIL

THE PANEL - Attachments to the basic panel. Second phase adapting of the building.

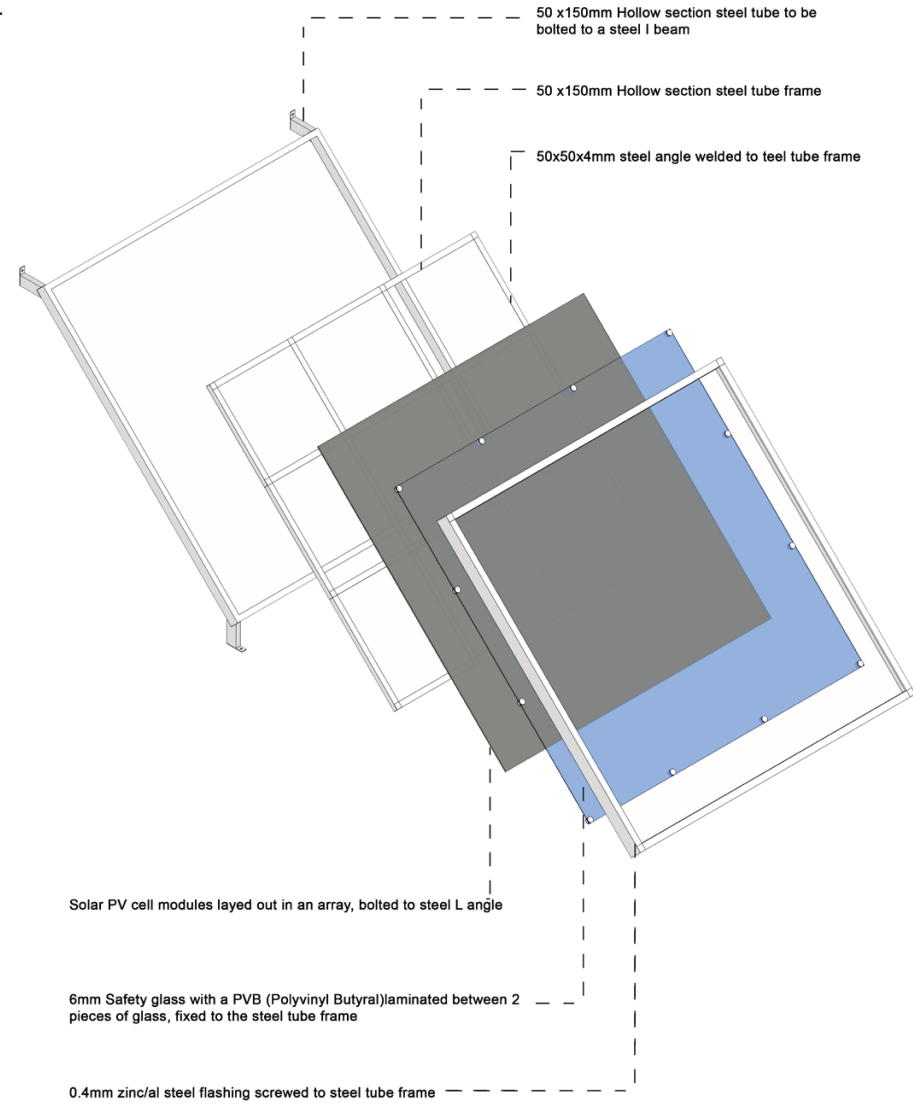
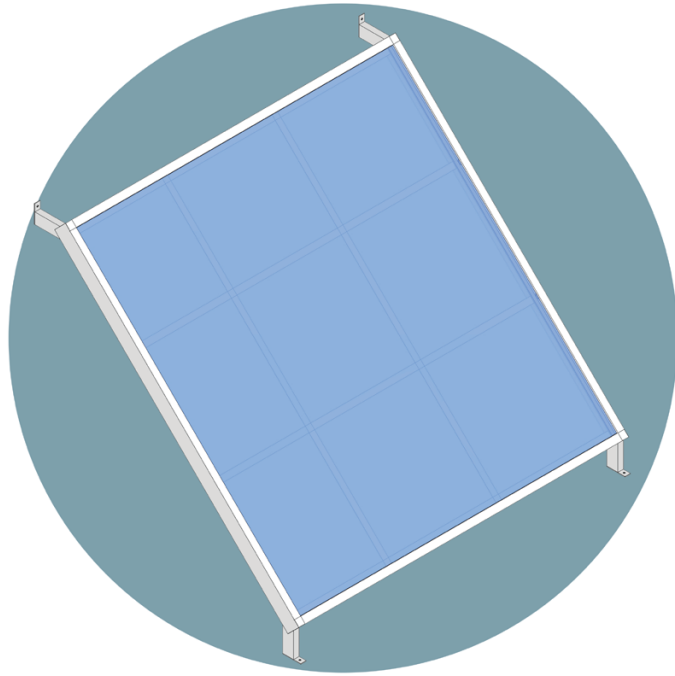
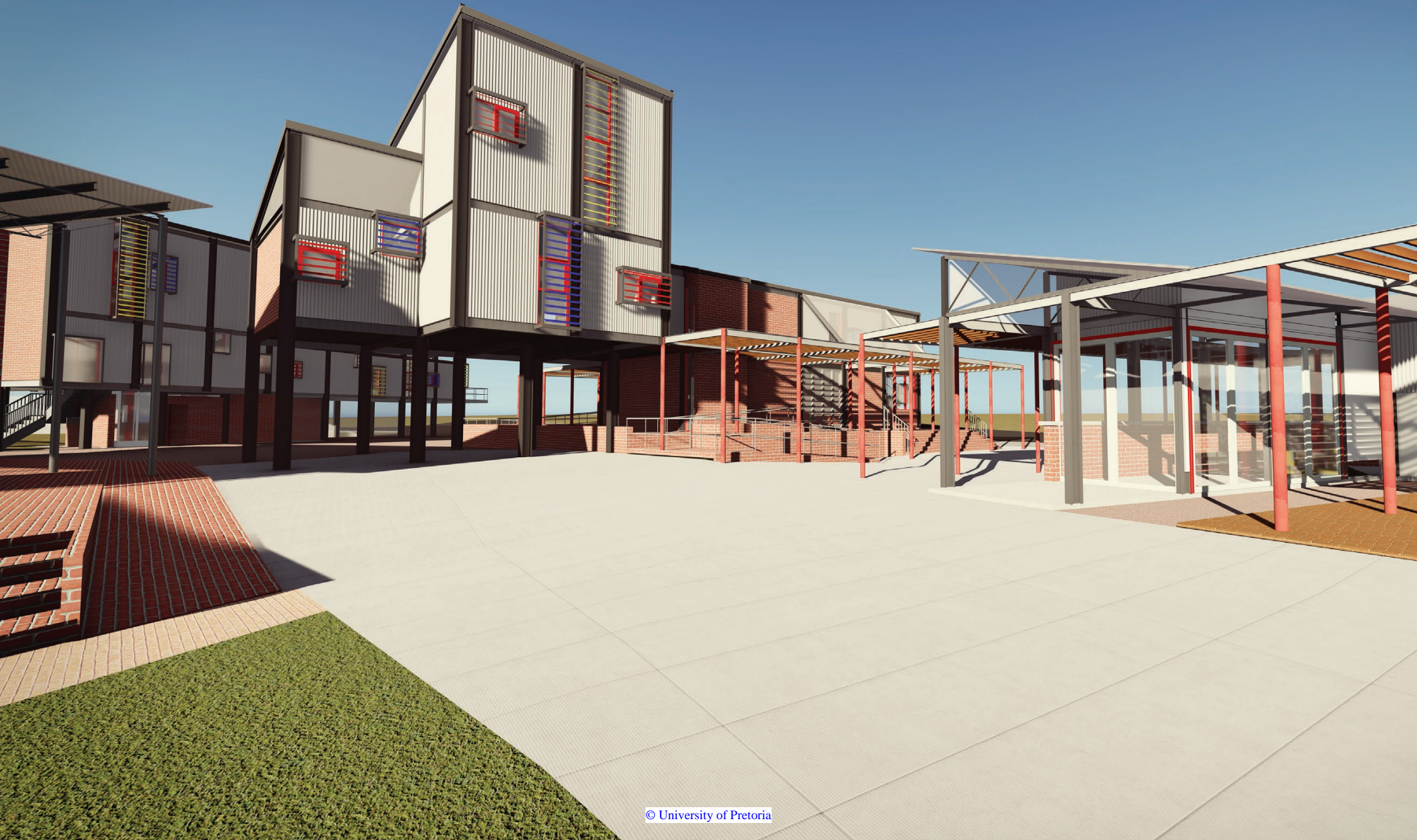

Figure 149: The solar panel. This becomes an attachment to the building and works with the 3x3x3 grid (Author 2016).



8.7.5 Shading attachments

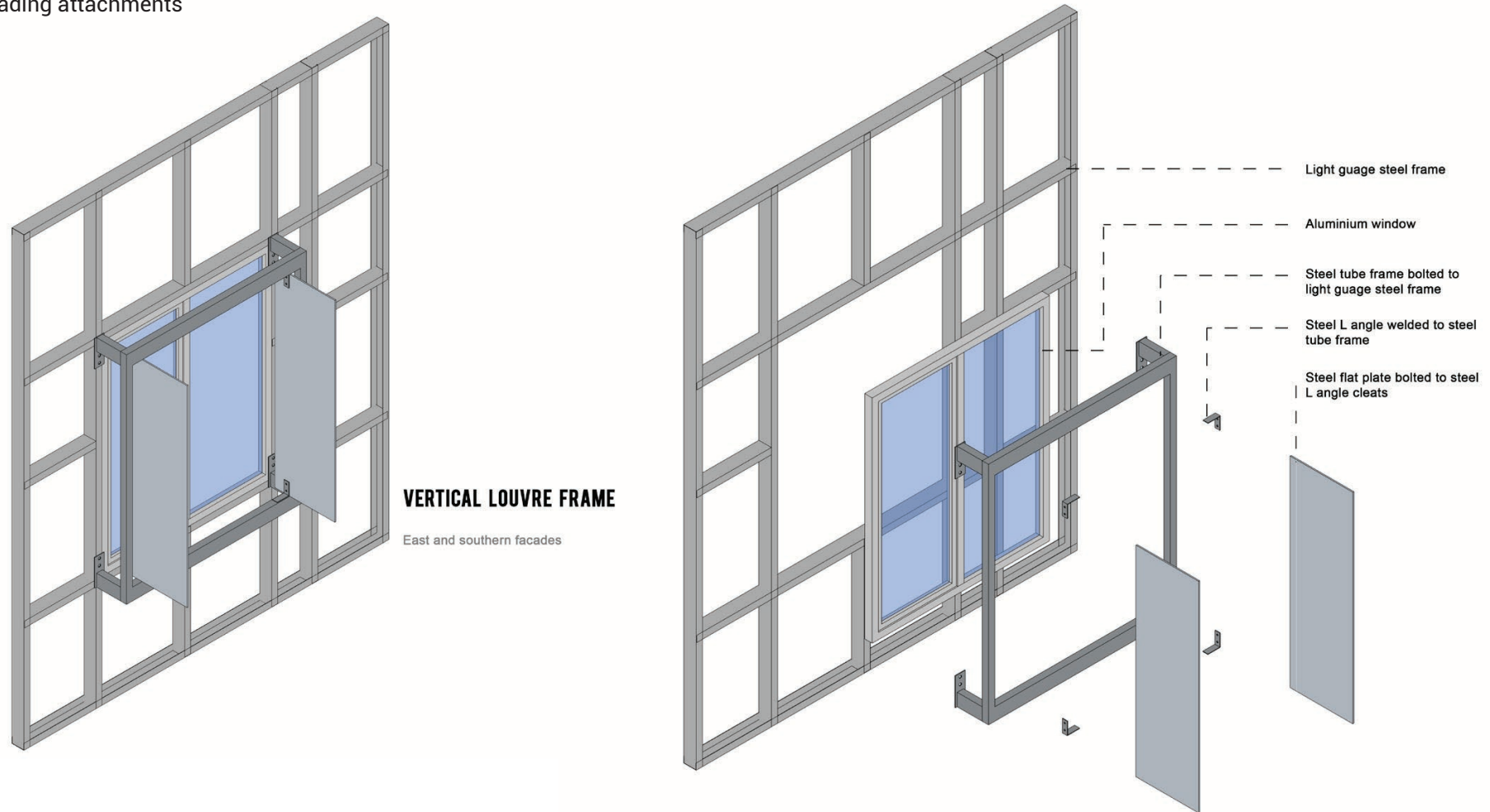
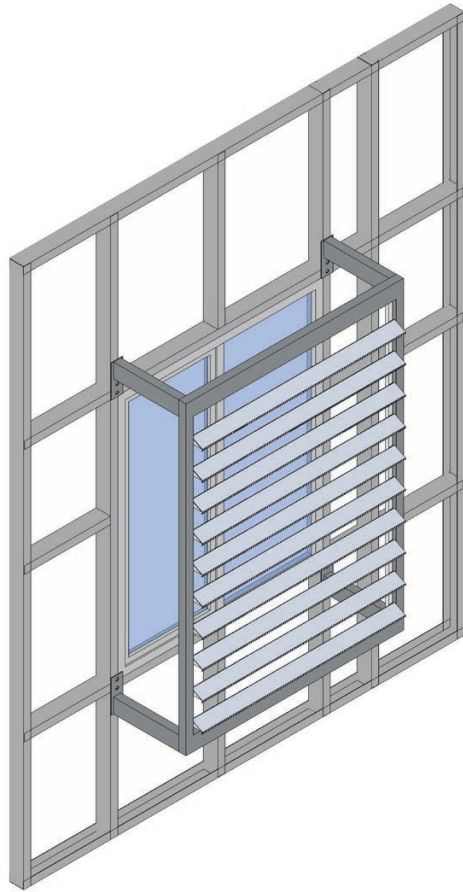
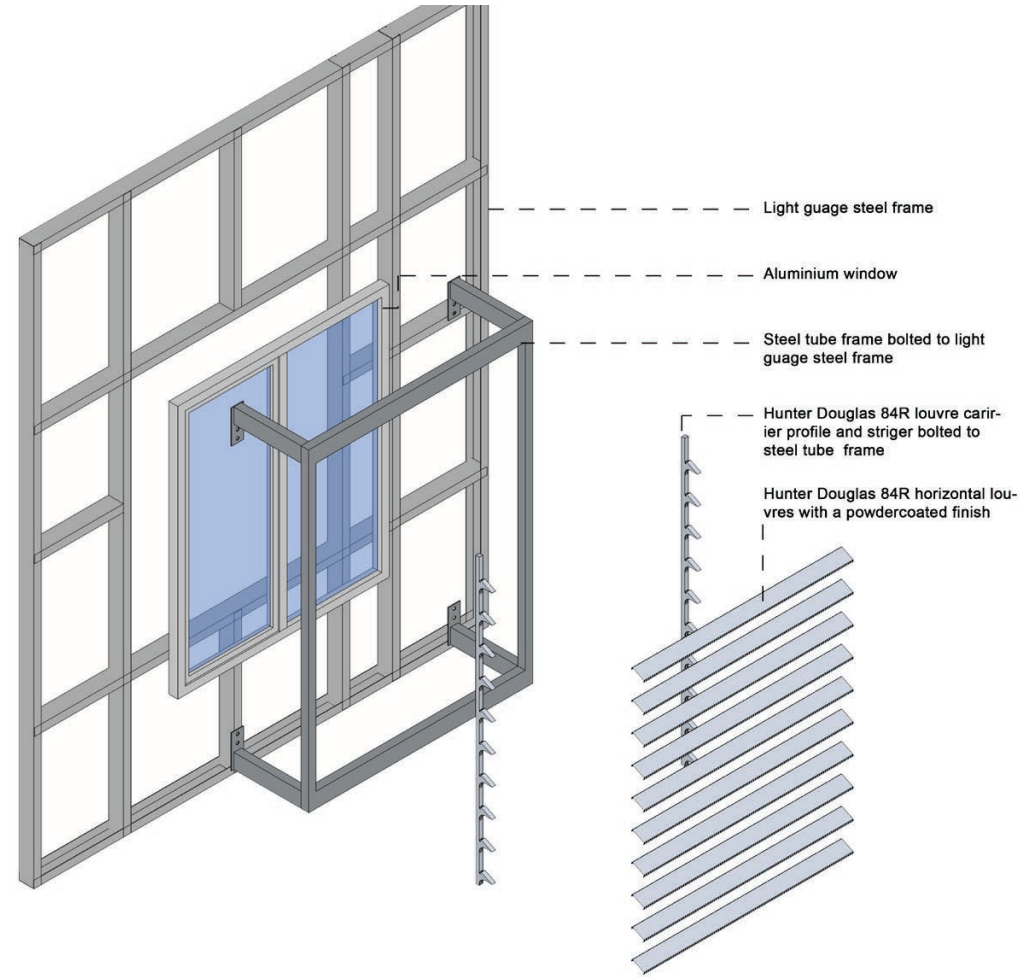

Figure 150: Shading system. The modular system leads to a building with no overhangs over the fenestration. The system allows the building to perform better climatically (Author 2016).



HORIZONTAL LOUVRE FRAME

Northern facades



Attachments

The following attachments form a system that is used to adapt the architecture. They become the second phase of adapting the building. The attachments have various roles to aid the sustainability of the building.

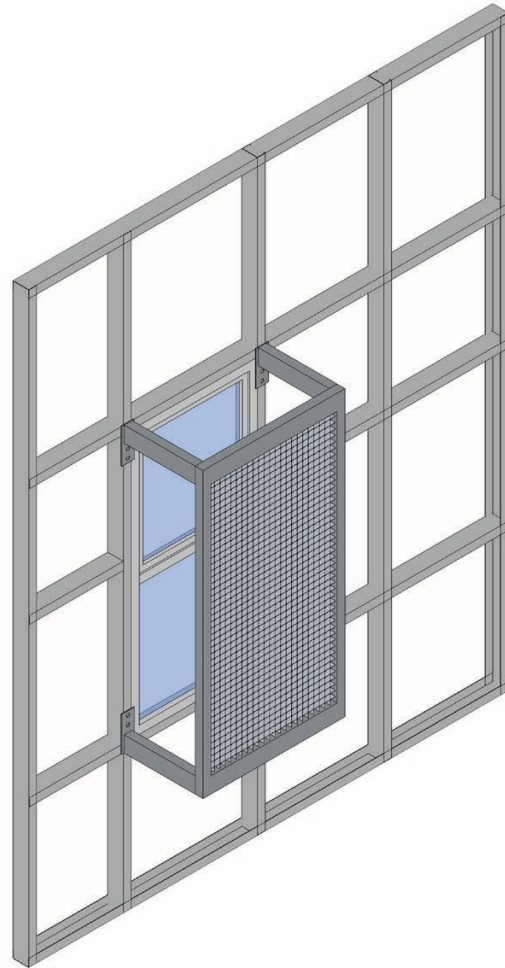

MENTIS LOUVRE FRAME

All facades. Used for privacy

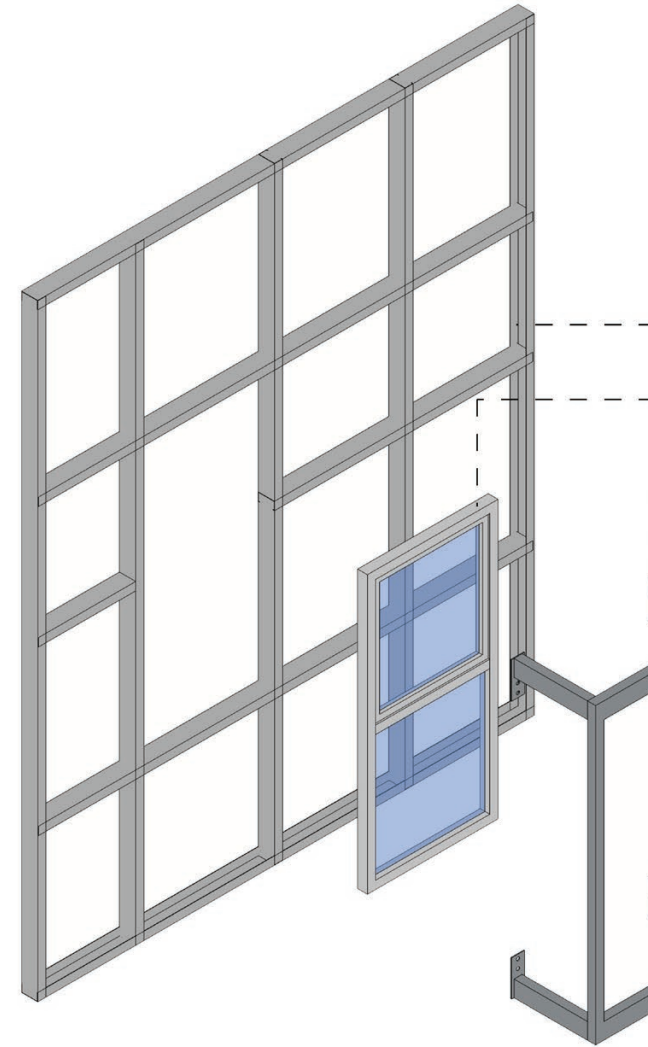
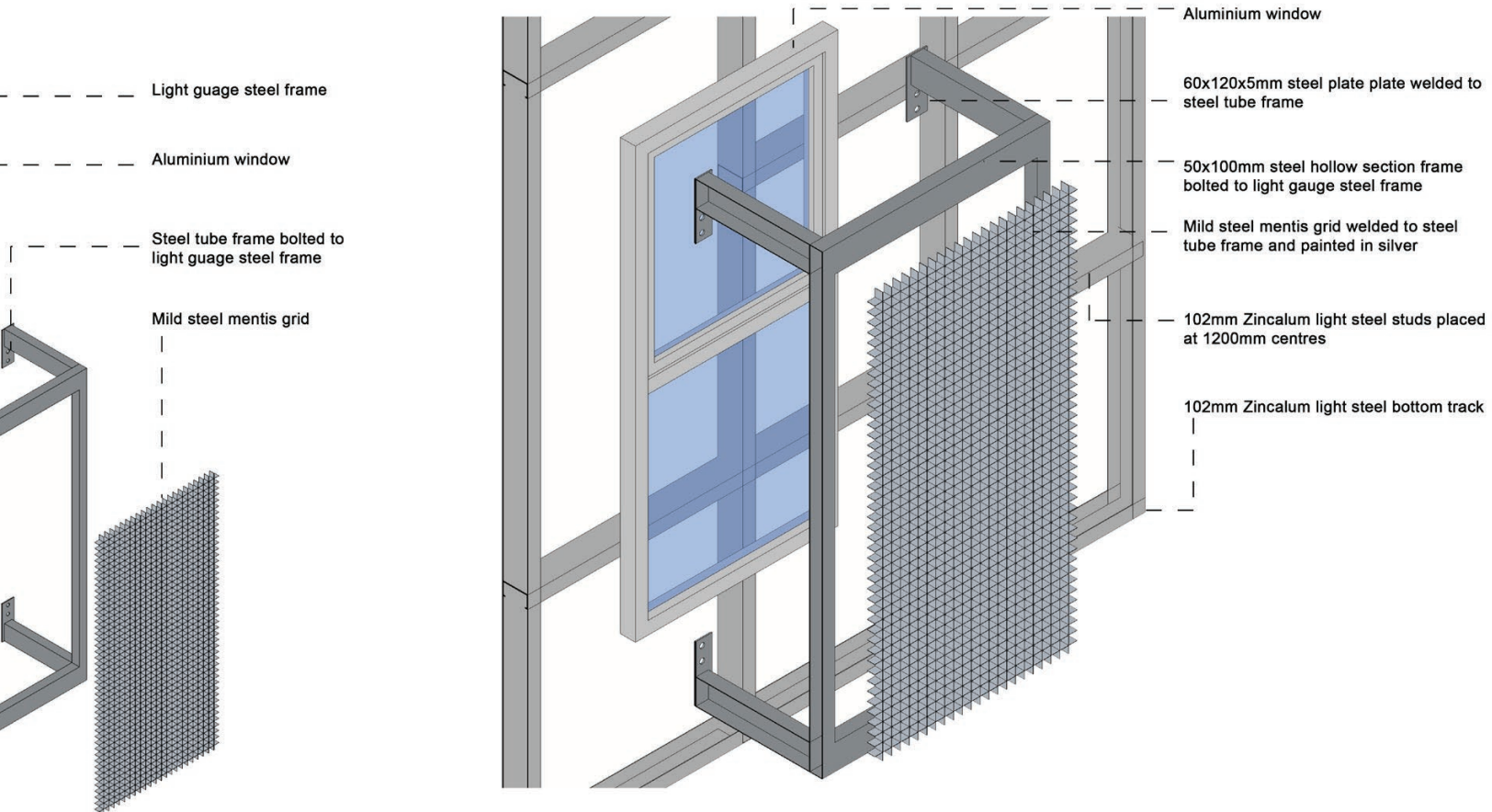

Figure 151: Shading system (Author 2016).



8.7.6 The adapted building

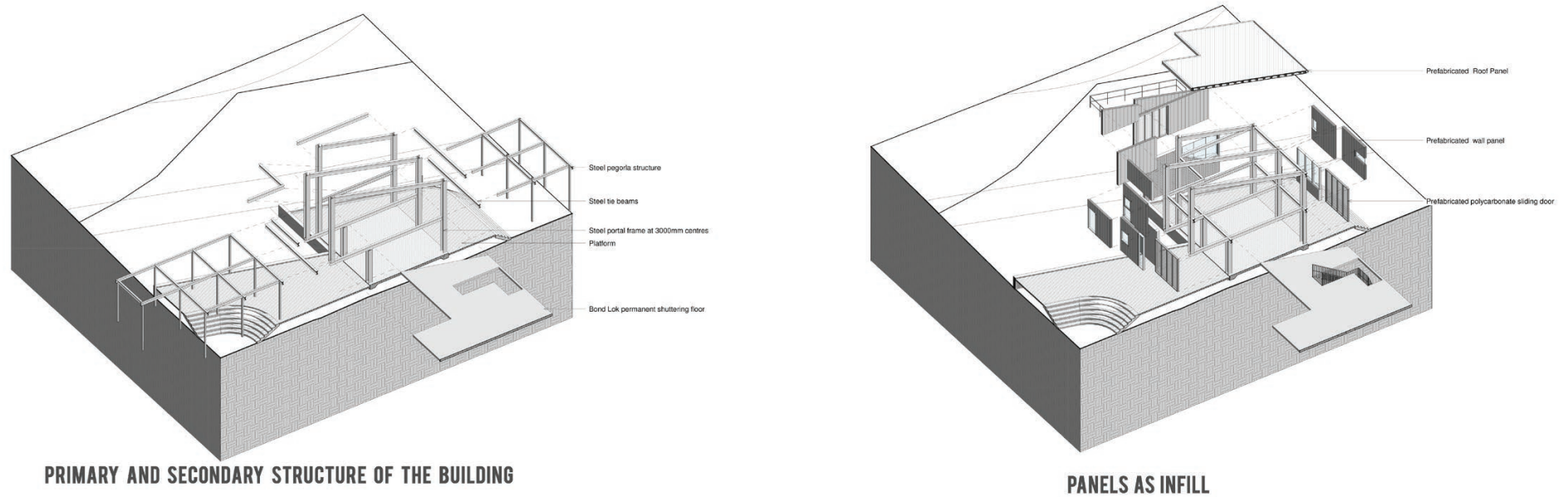
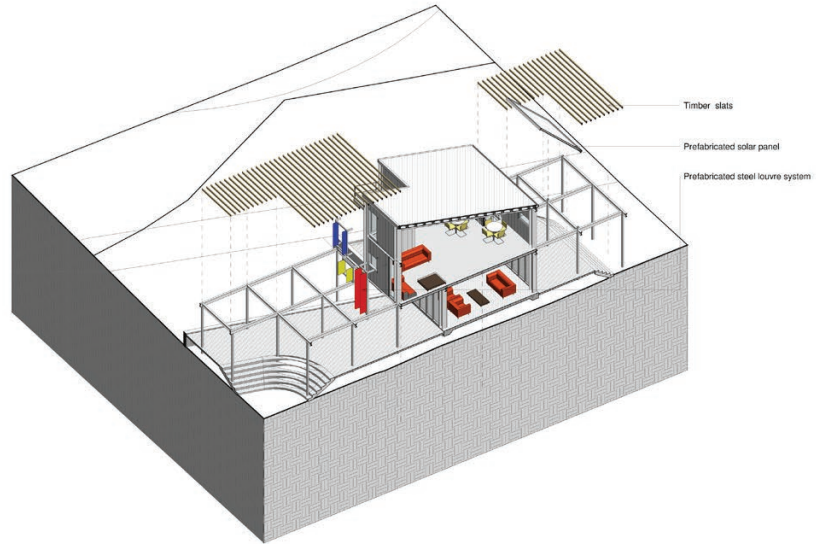
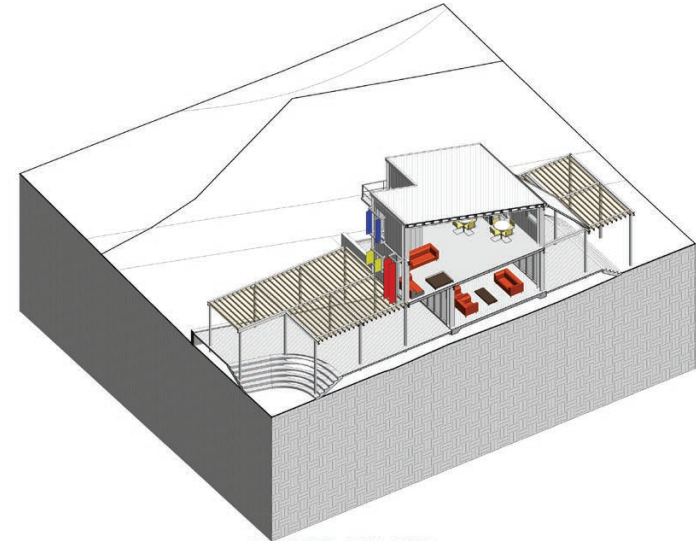

Figure 152: The adapting of the building over time (Author 2016).



ADDING ATTACHEMENTS



ADAPTED BUILDING

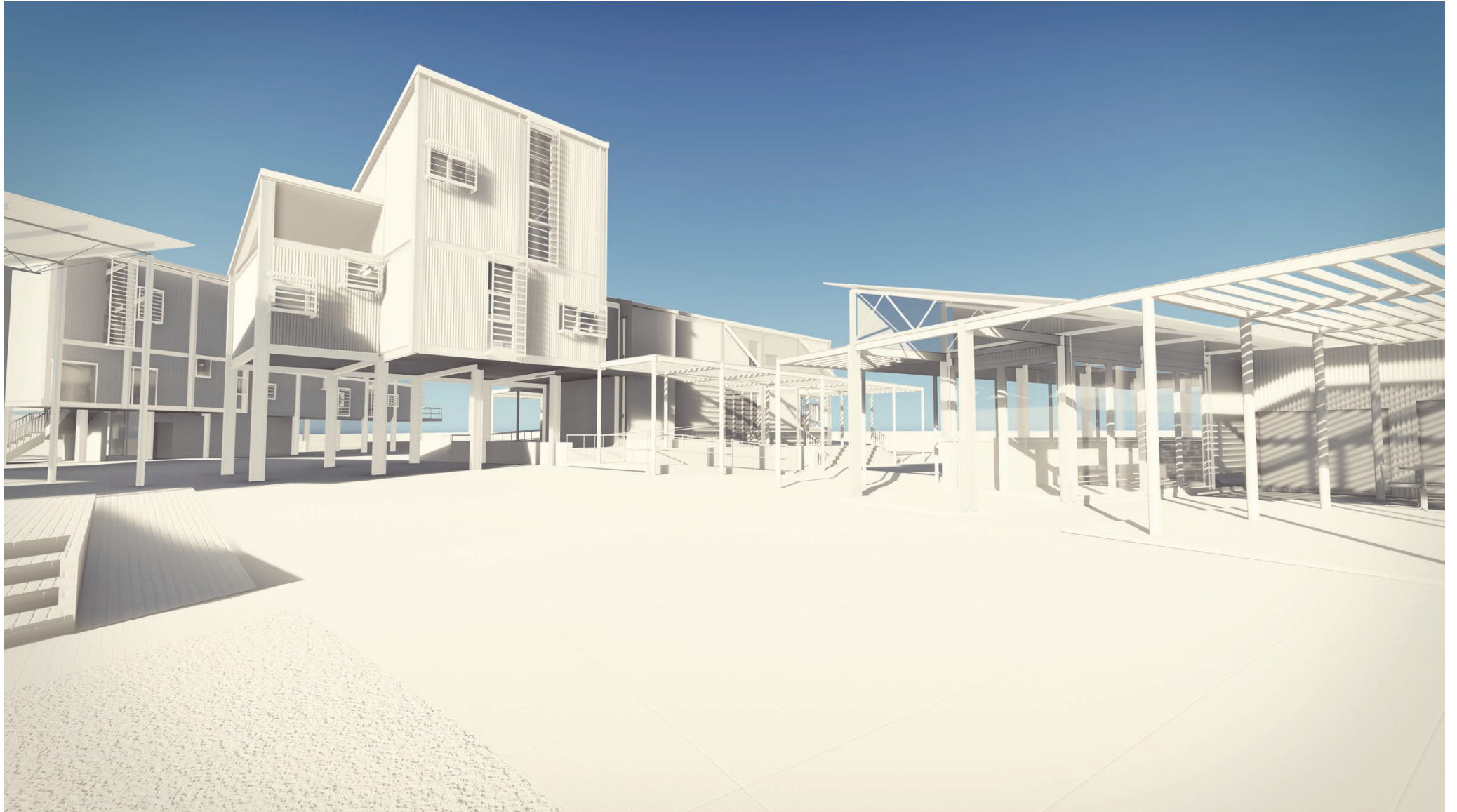
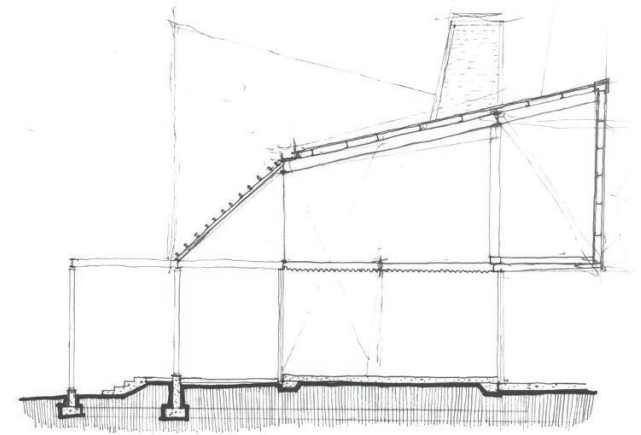
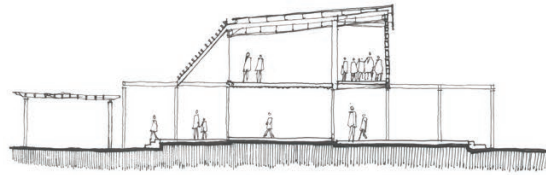

Figure 153:3D rendering of the building in its adapted phase with both panels and attachments (Author 2016).



Figure 154:3D rendering of the building in its adapted phase with both panels and attachments (Author 2016).



Two buildings are detailed to investigate the two different primary structure employed in the design project. The Administration building uses a portal frame structure while the community hall uses a beam and column structure. The connection between the structure and the prefabricated panels are investigated.

Three sections of the administration building are developed to illustrate the possible frame infill depending on the internal function as well as the orientation of the planes.

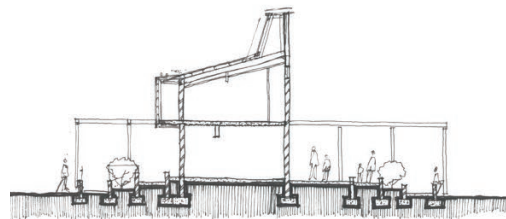
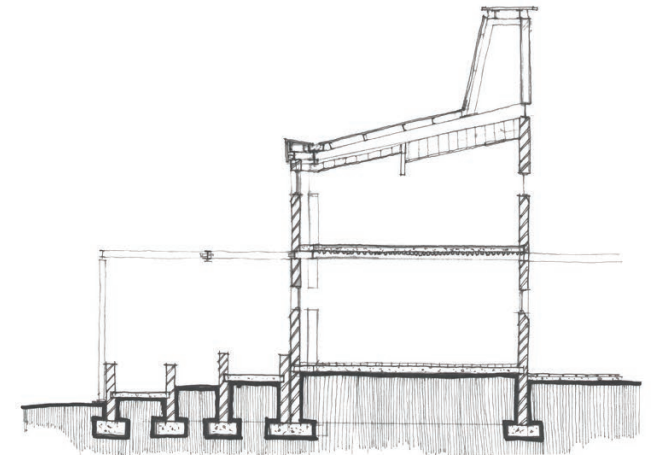

Figure 155: Admin building sections (Author 2016).



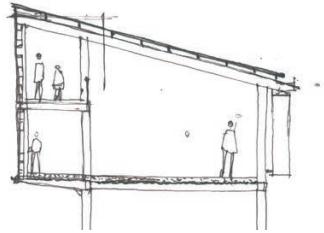
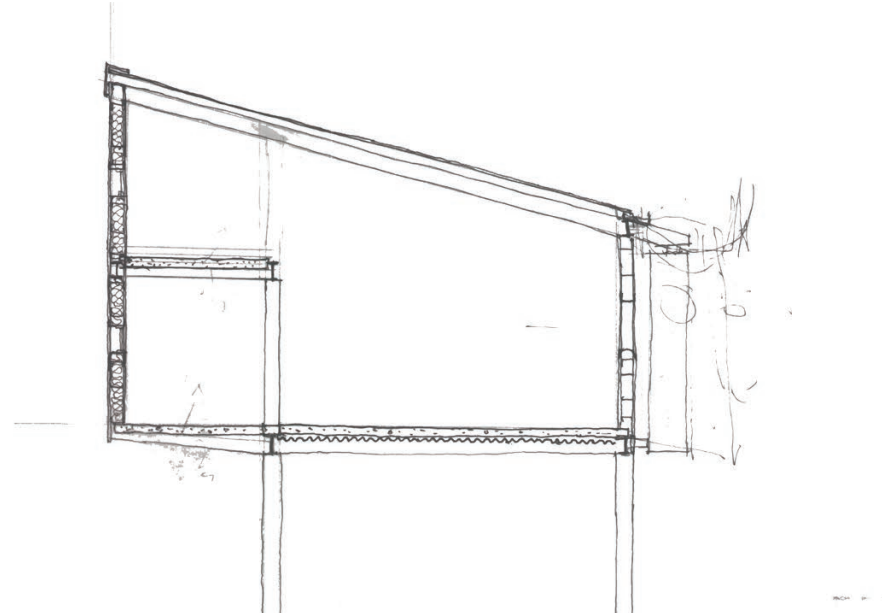

Figure 156: Admin building sections (Author 2016).



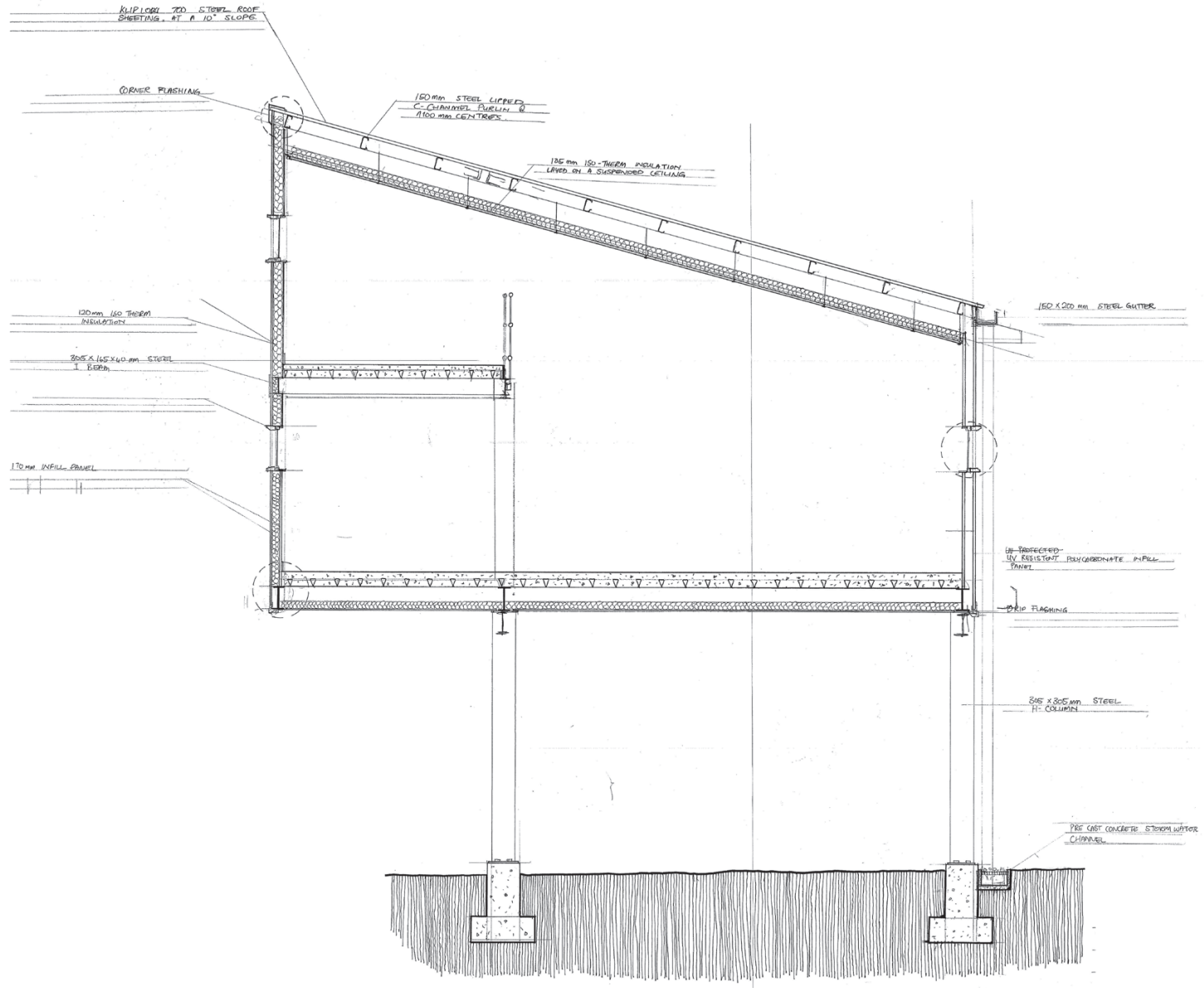

Figure 157: Technical exploration of the administration building N.T.S (Author 2016).

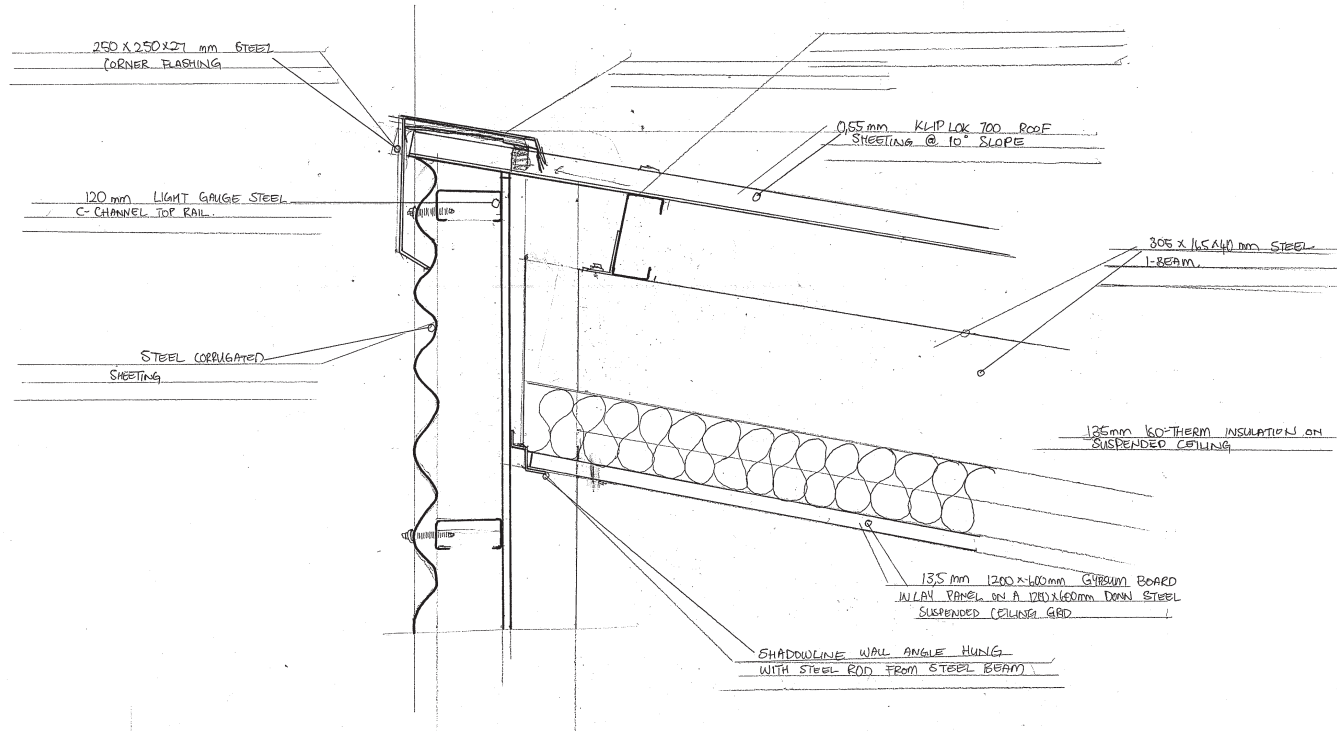

Figure 158: Roof detail N.T.S (Author 2015)

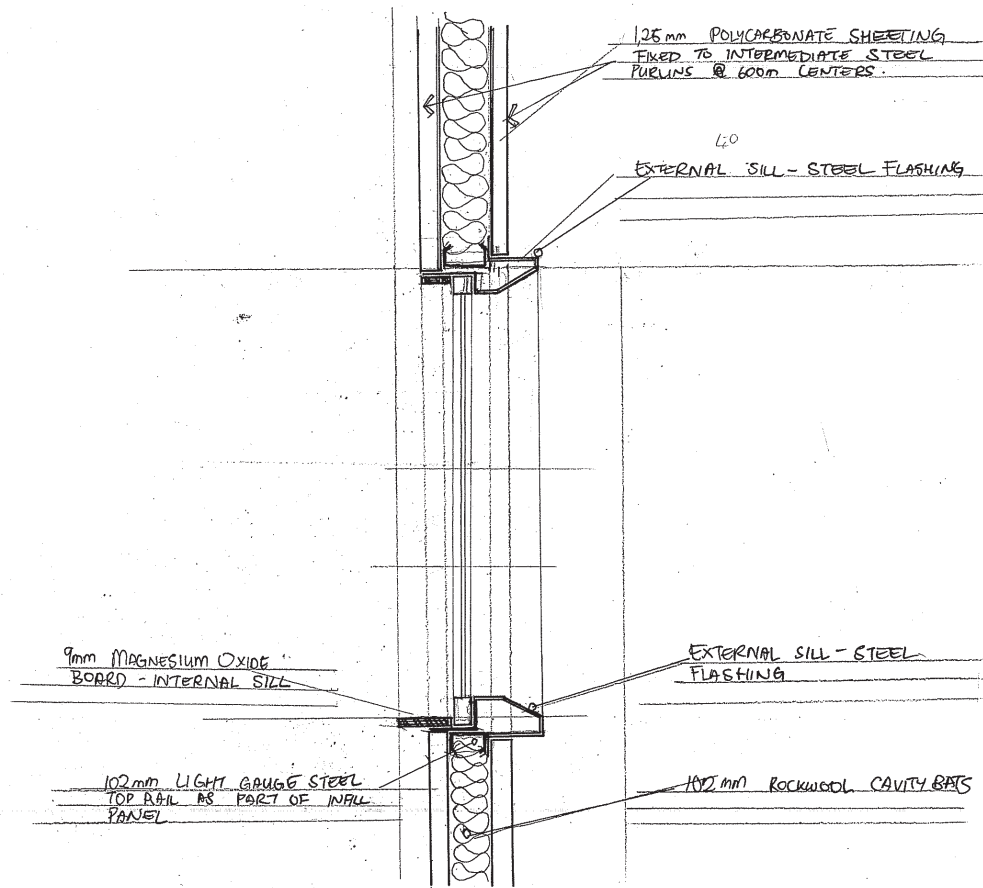

Figure 159: Window detail N.T.S (Author 2016)

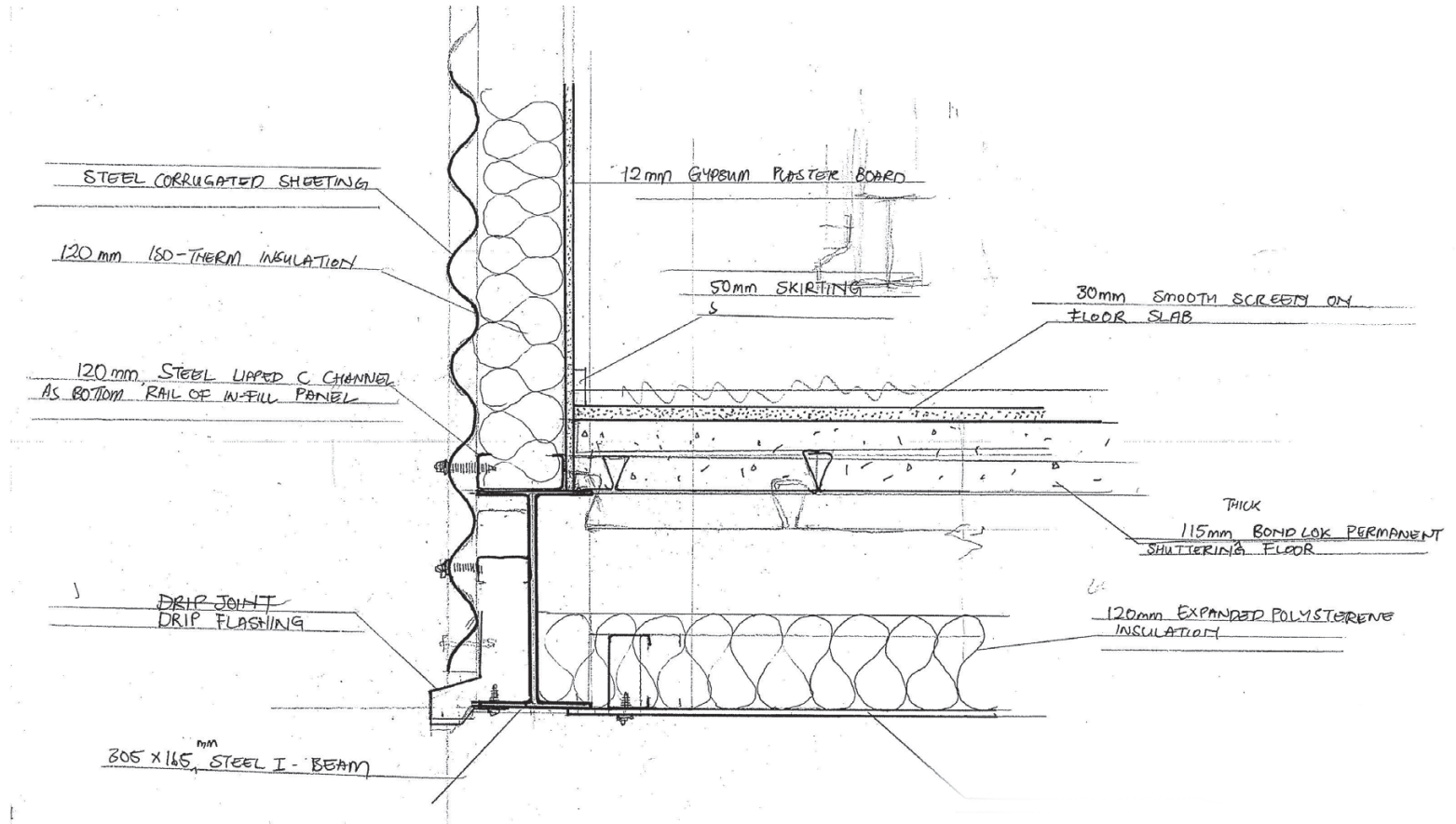
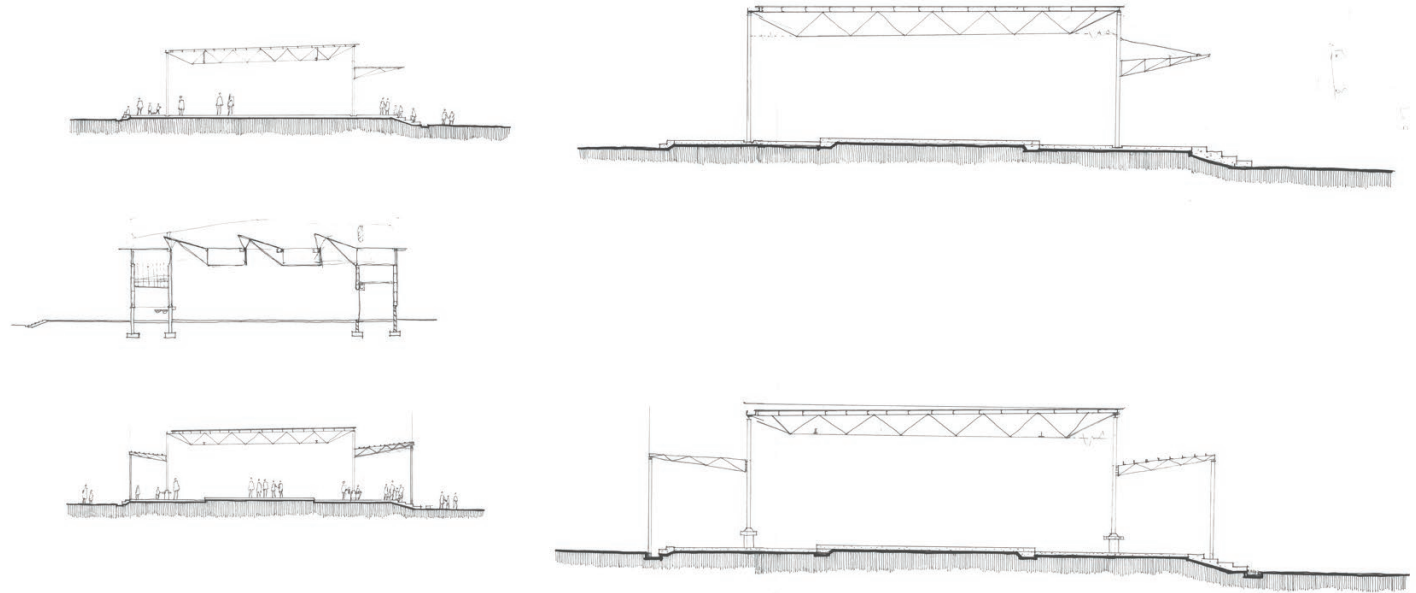

Figure 160: Wall to floor detail connection (Author 2016).



The community hall is a portal between the communal public space and the soccer field. As such, the building has two service cores on either end with the roof beams support on the towers and the columns on the platform. A threshold space is created to celebrate the soccer field. The, roof structure and platform to column connection are investigated.

Figure 161:Community sectional development: Thresholds and structure (Author 2016).

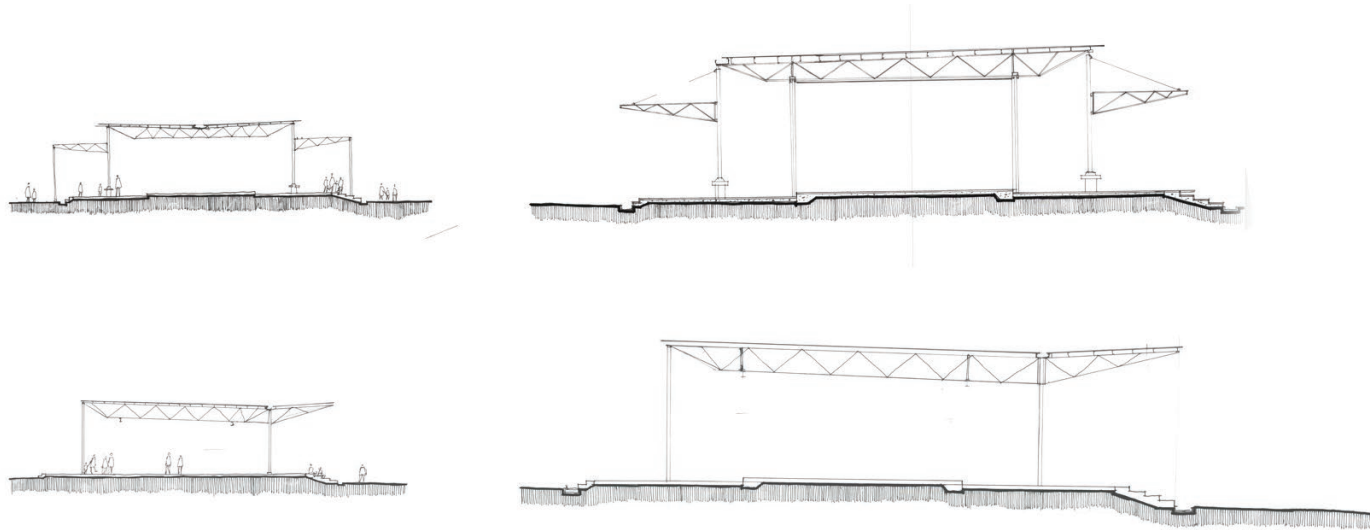

Figure 162:Community sectional development: Thresholds and structure (Author 2016).

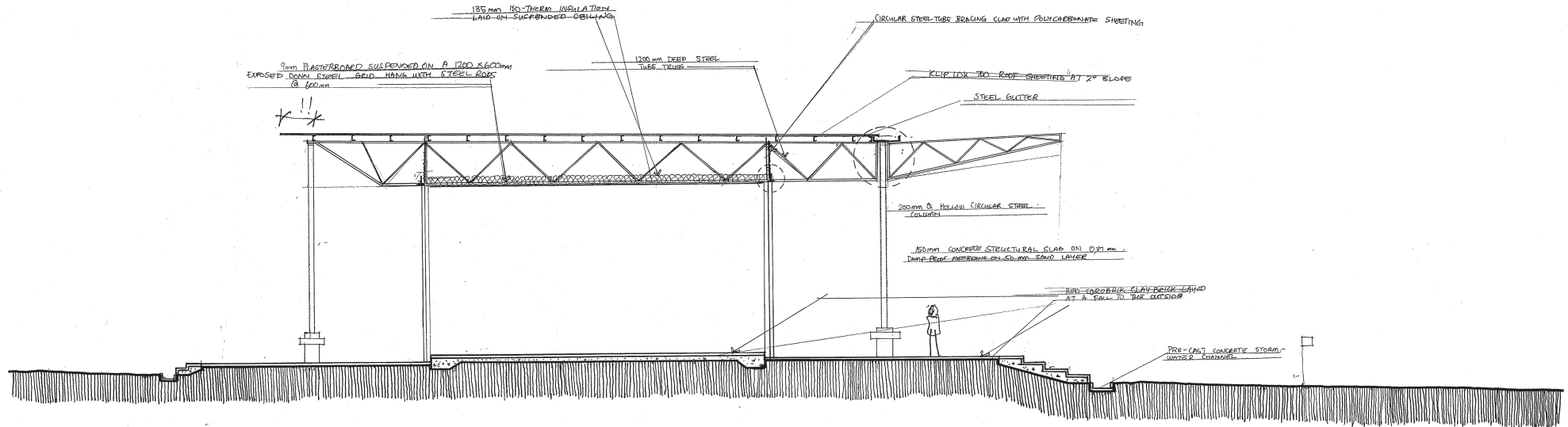

Figure 163: The community hall detail investigation (Author 2016).

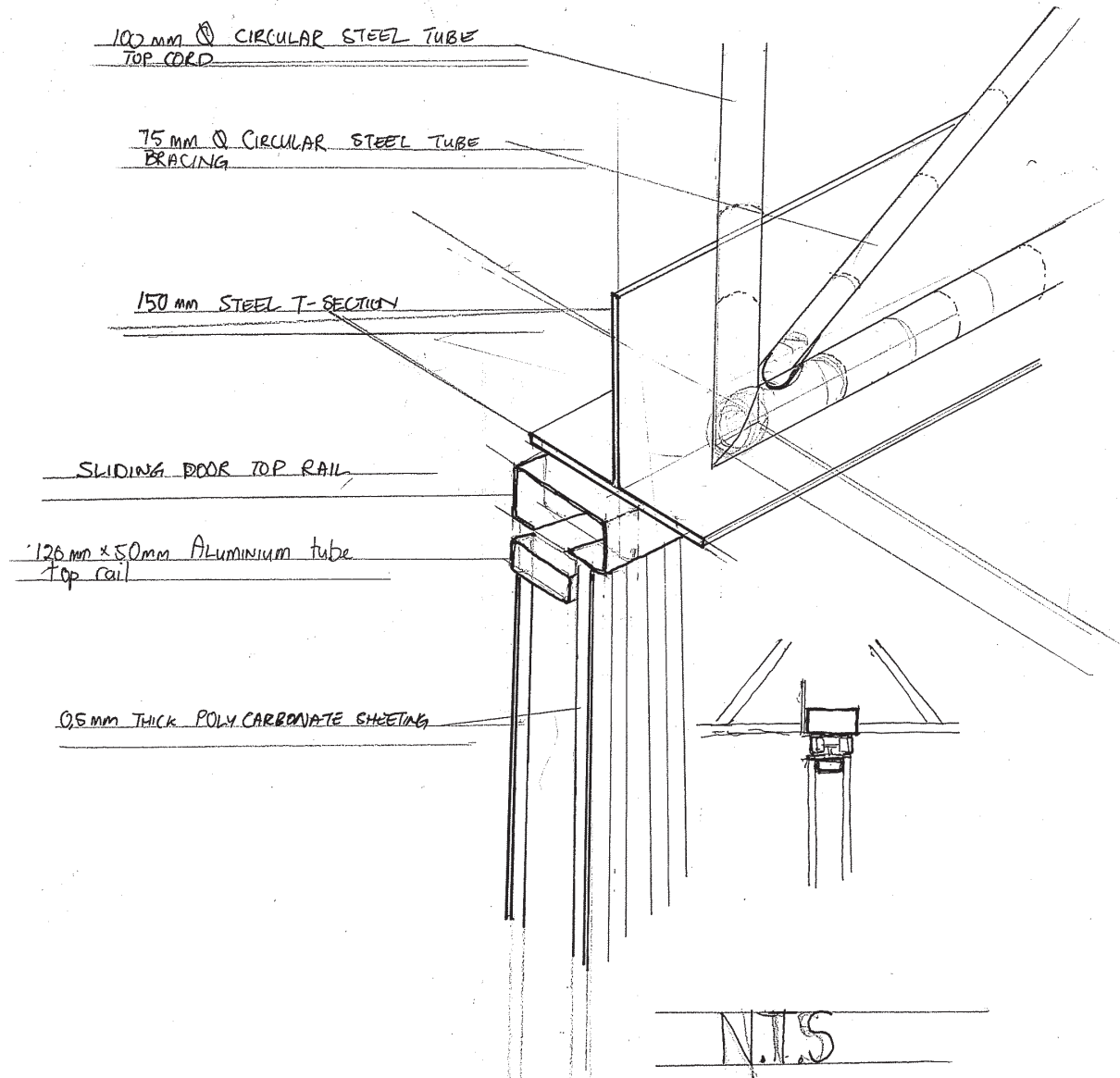

Figure 164: Detail connection of the door panel and rail to the structure of the community hall (Author 2016).

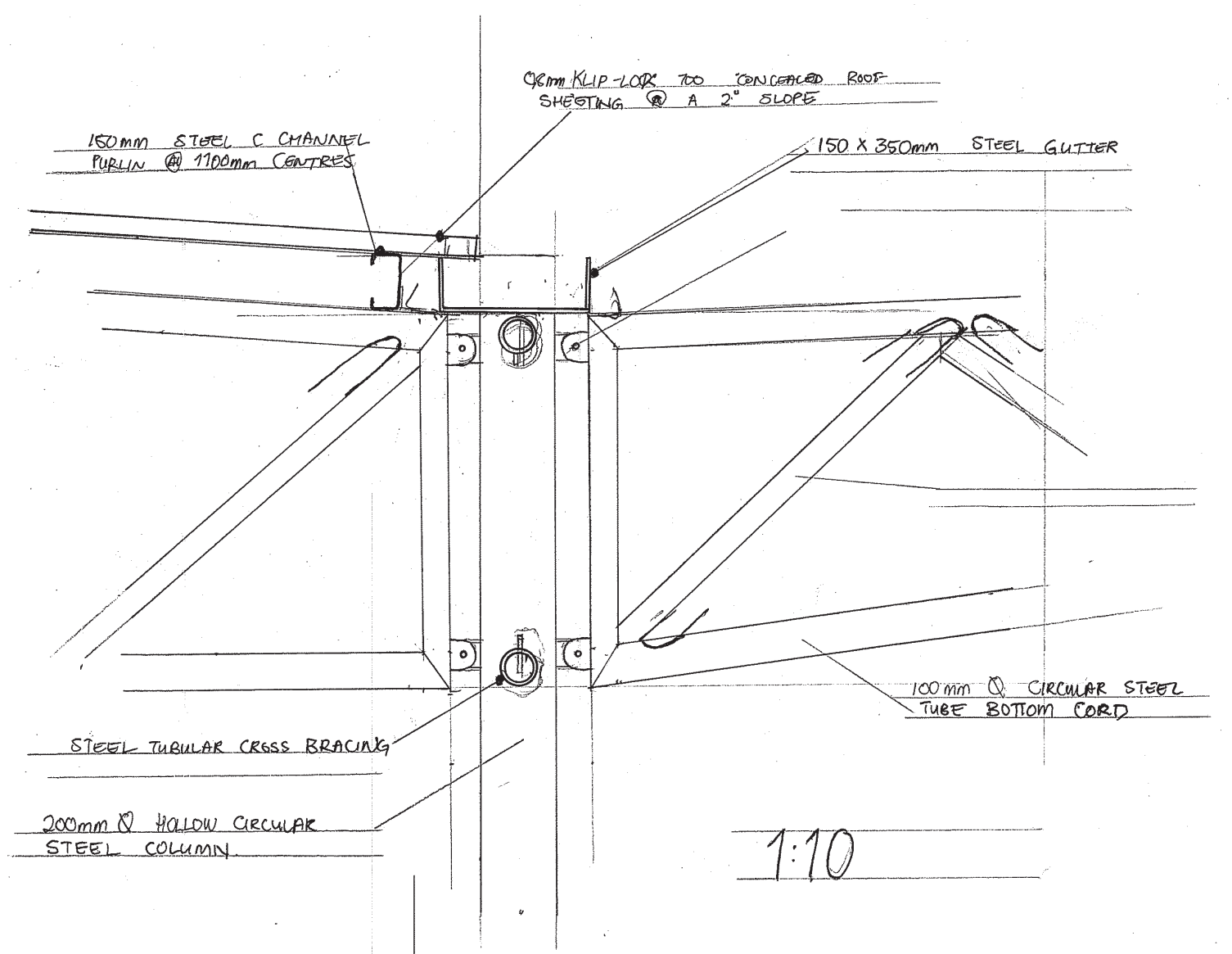

Figure 165: Beam to column and brace detail N.T.S (Author 2016).

8.9 FINAL DETAILING

The final detailing of the building brings together the detailing from the investigation of the panel system into the context of the buildings' structural frame.

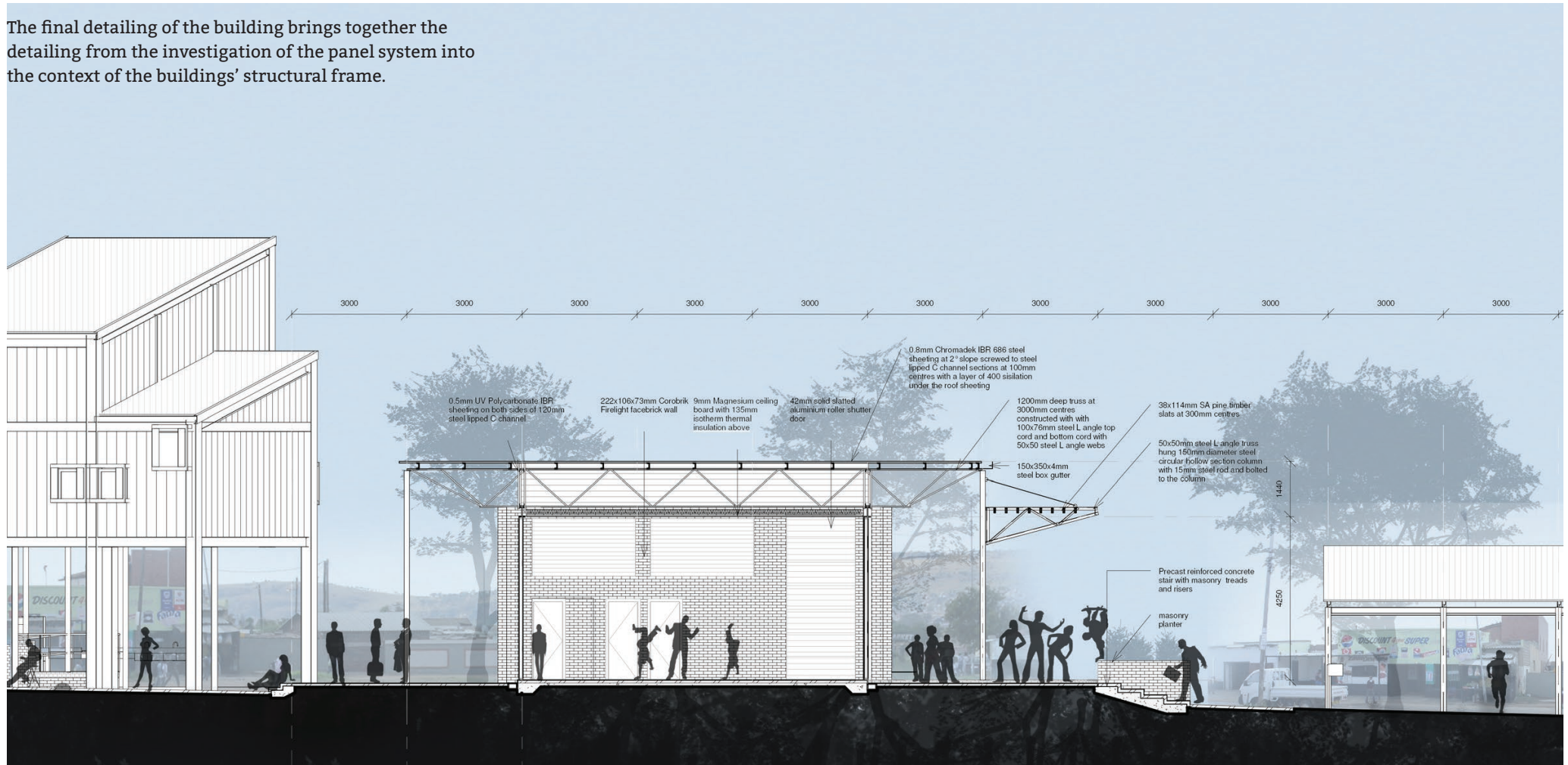

Figure 166: Hall section. 1:100 in Presentation. Section cut to show the Community Hall in context (Author 2016).

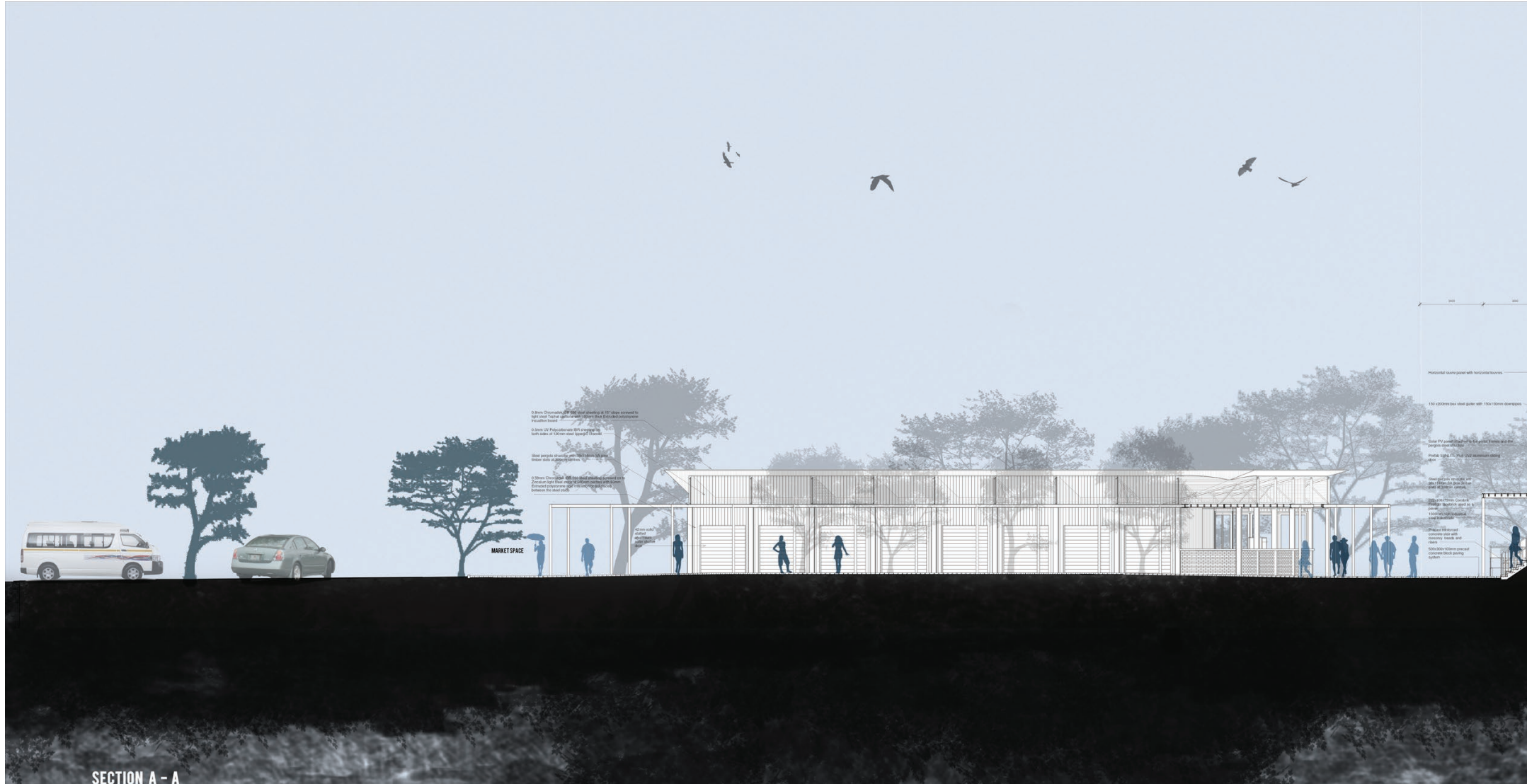
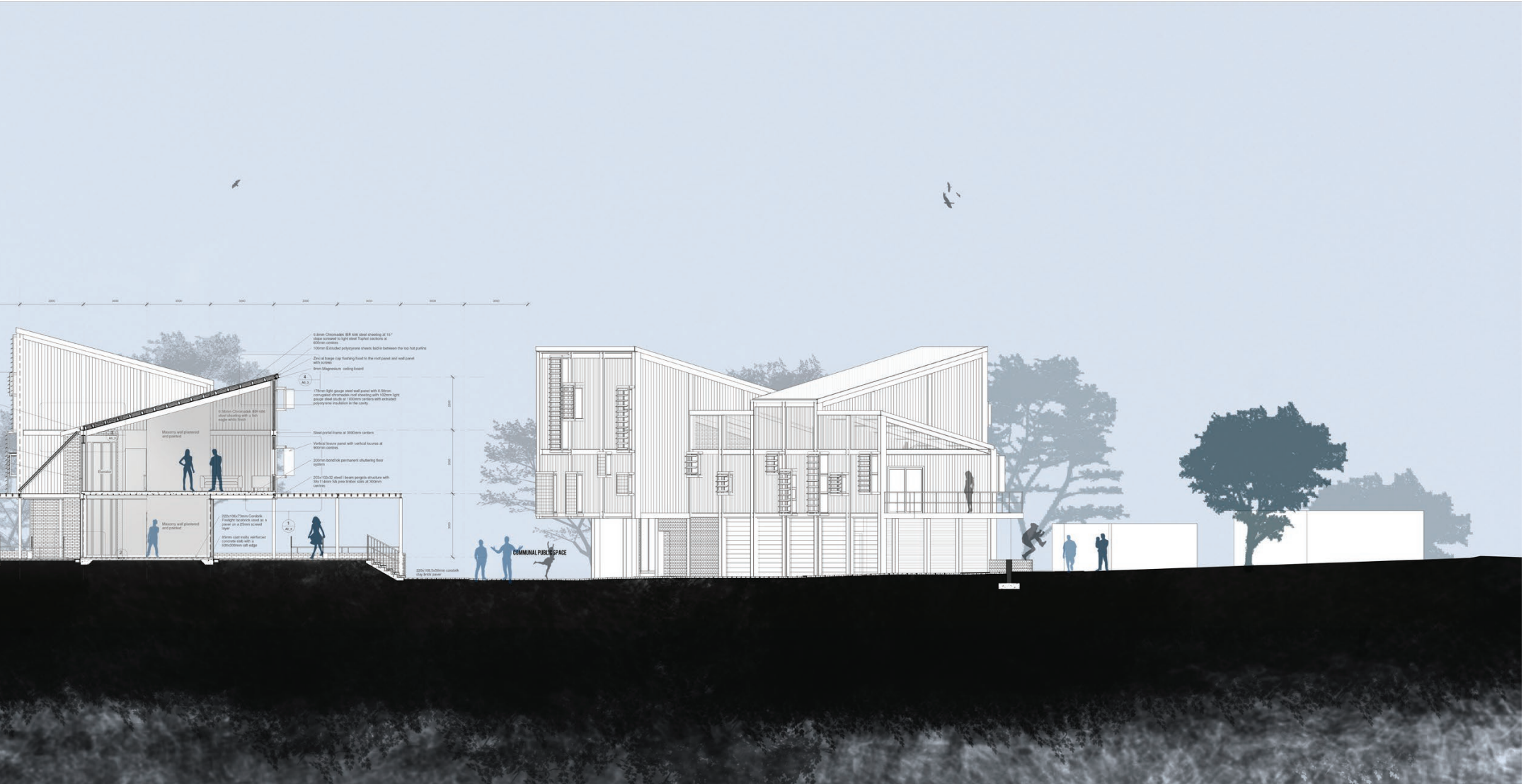

Figure 167: Administration building section. 1:50 in presentation (Author 2016).



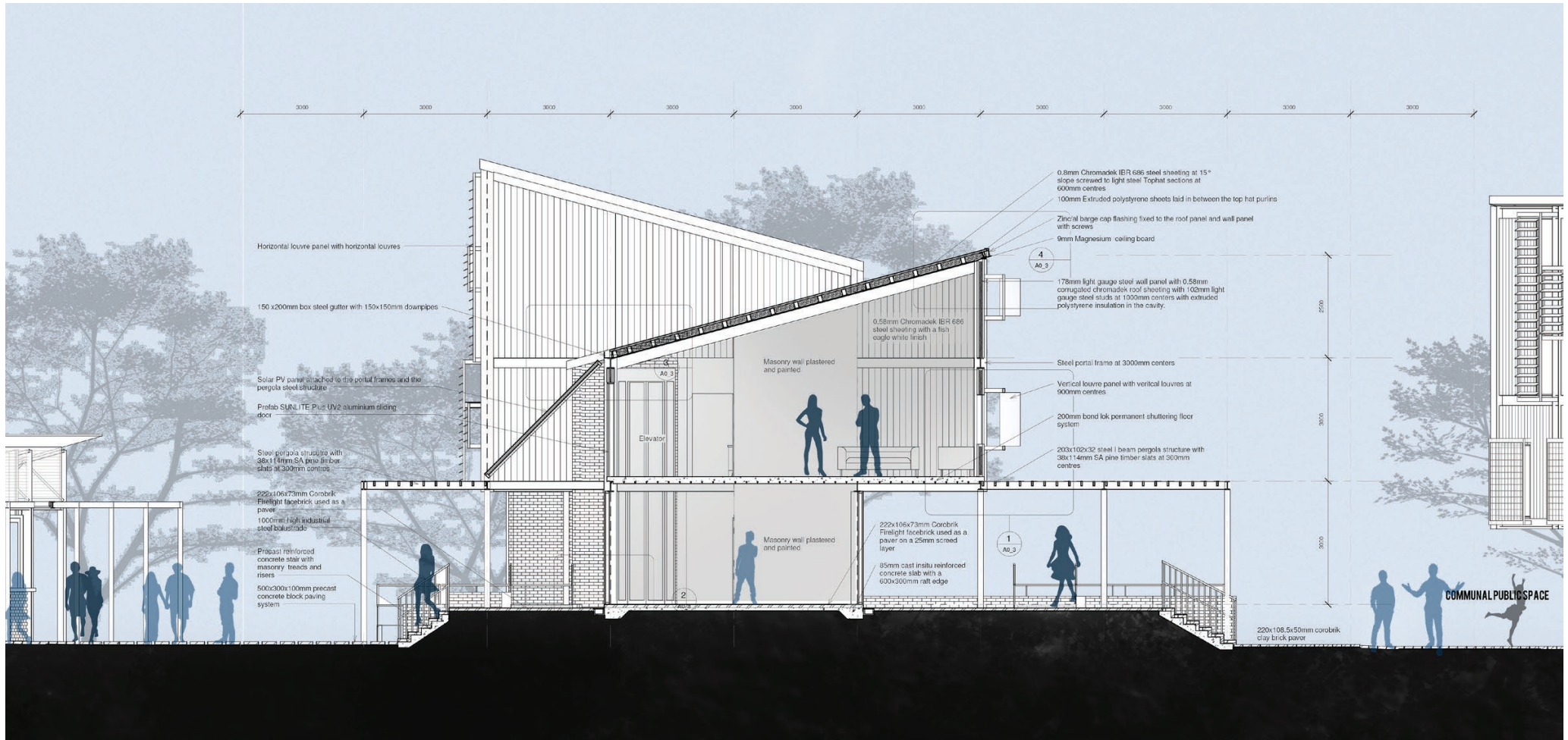
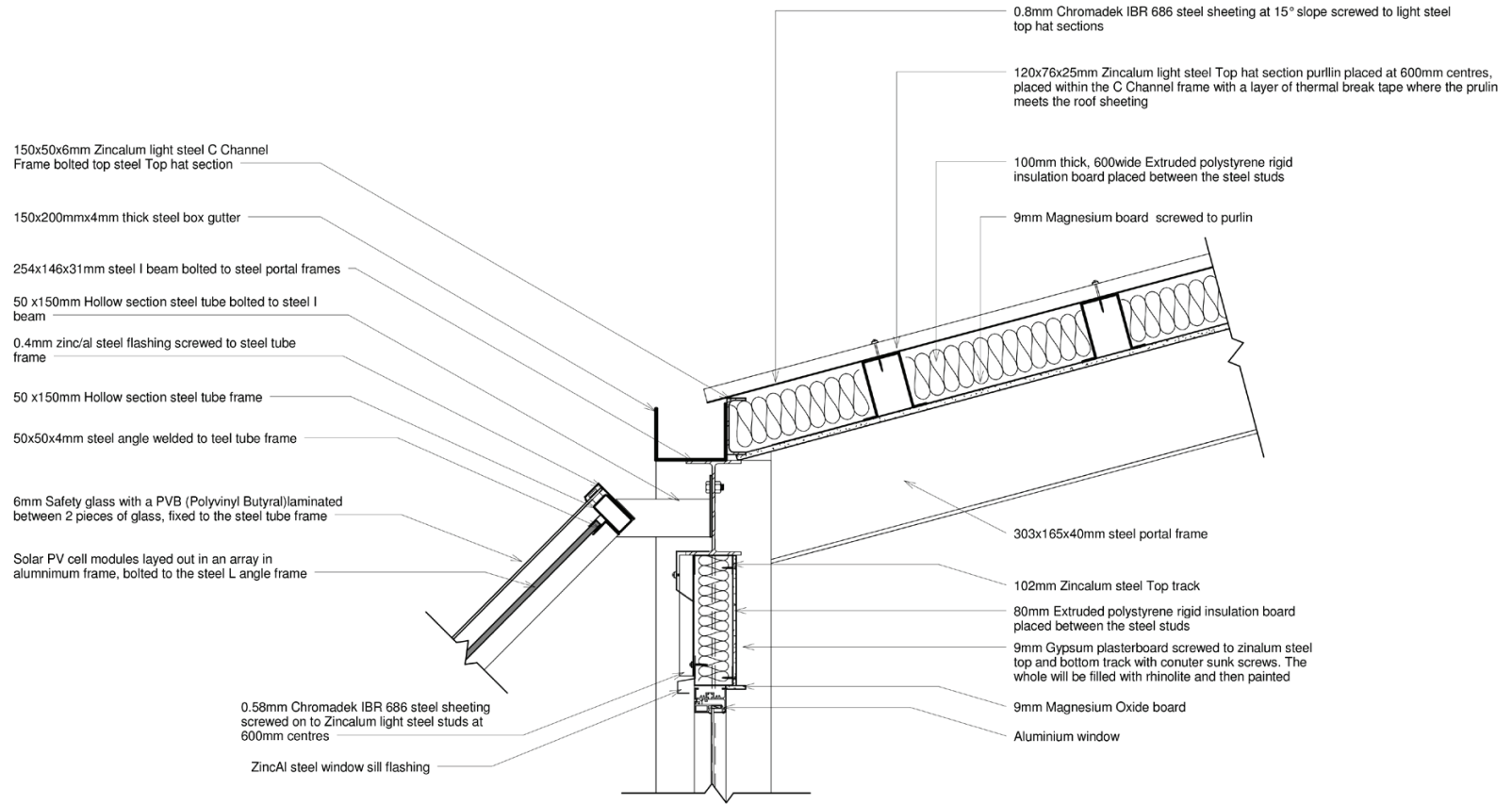
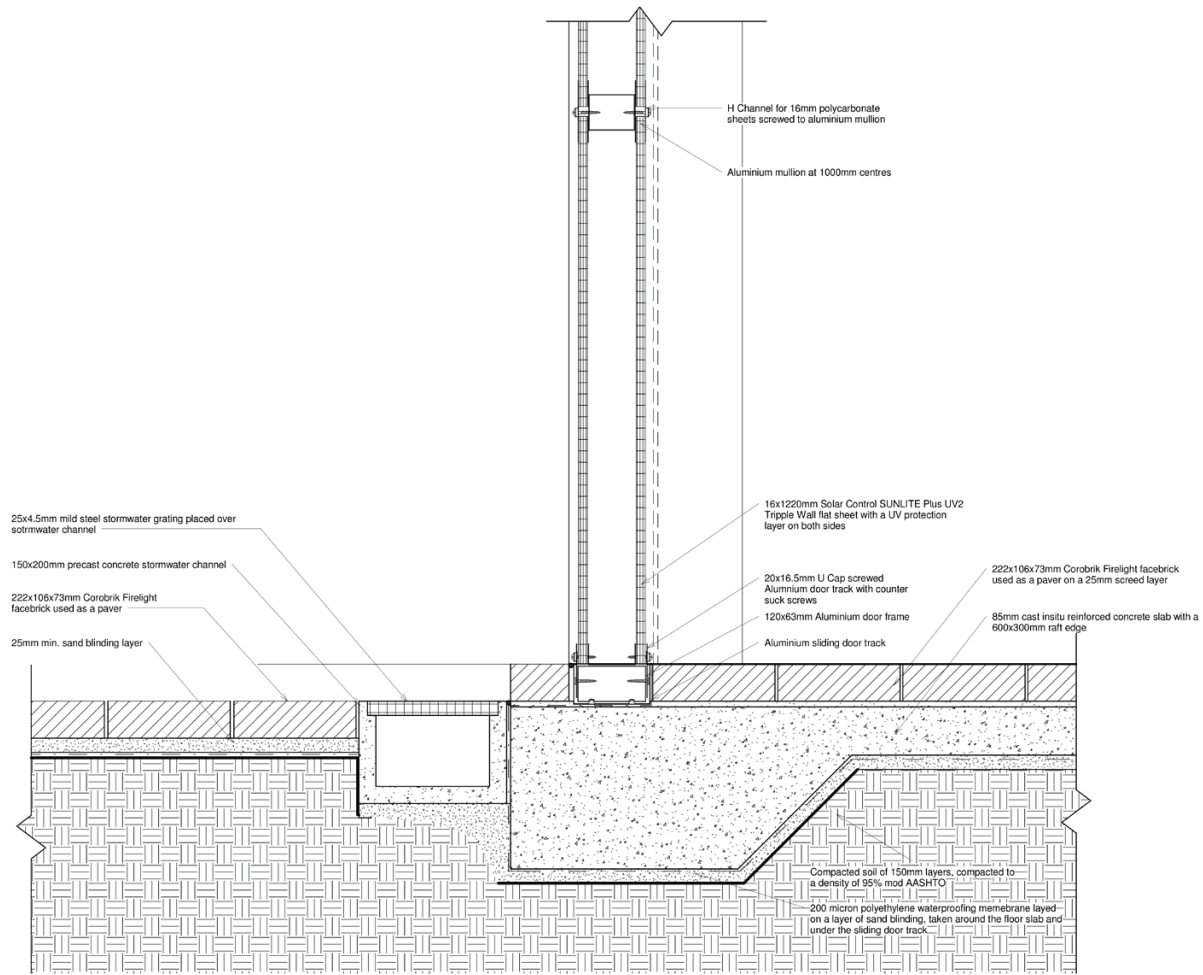

Figure 168: Administration section (Author 2016).



GUTTER / SOLAR PANEL DETAIL

Figure 169:Gutter / solar panel detail. 1:10 in Presentation (Author 2016).



2 FLOORDETAIL

Figure 170: Floor / sliding door detail. 1.5 in presentation (Author 2016).

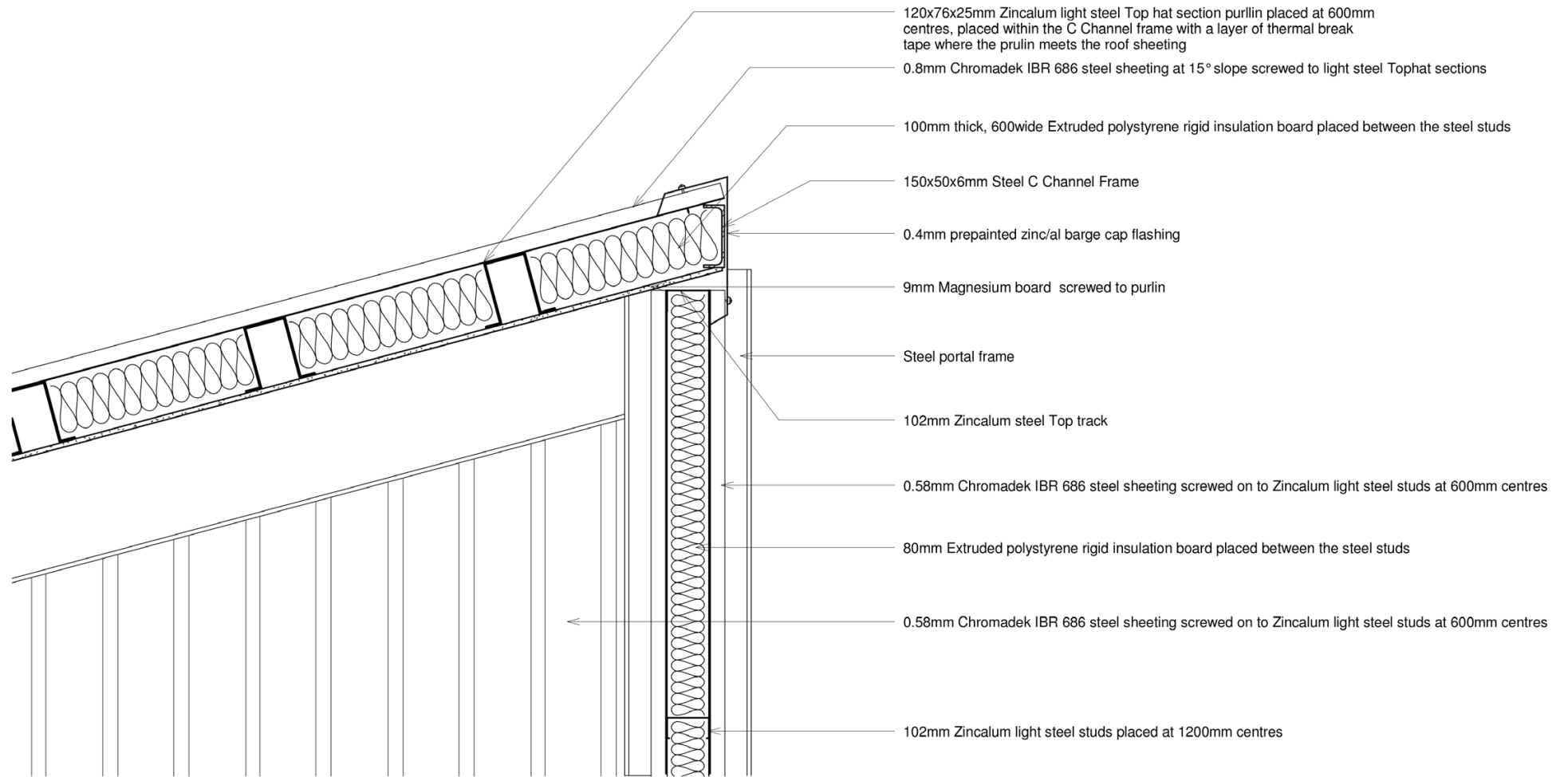

ROOF / WALL DETAIL

Figure 171:Roof to wall detail. !:5 in presentation (Author 2016).

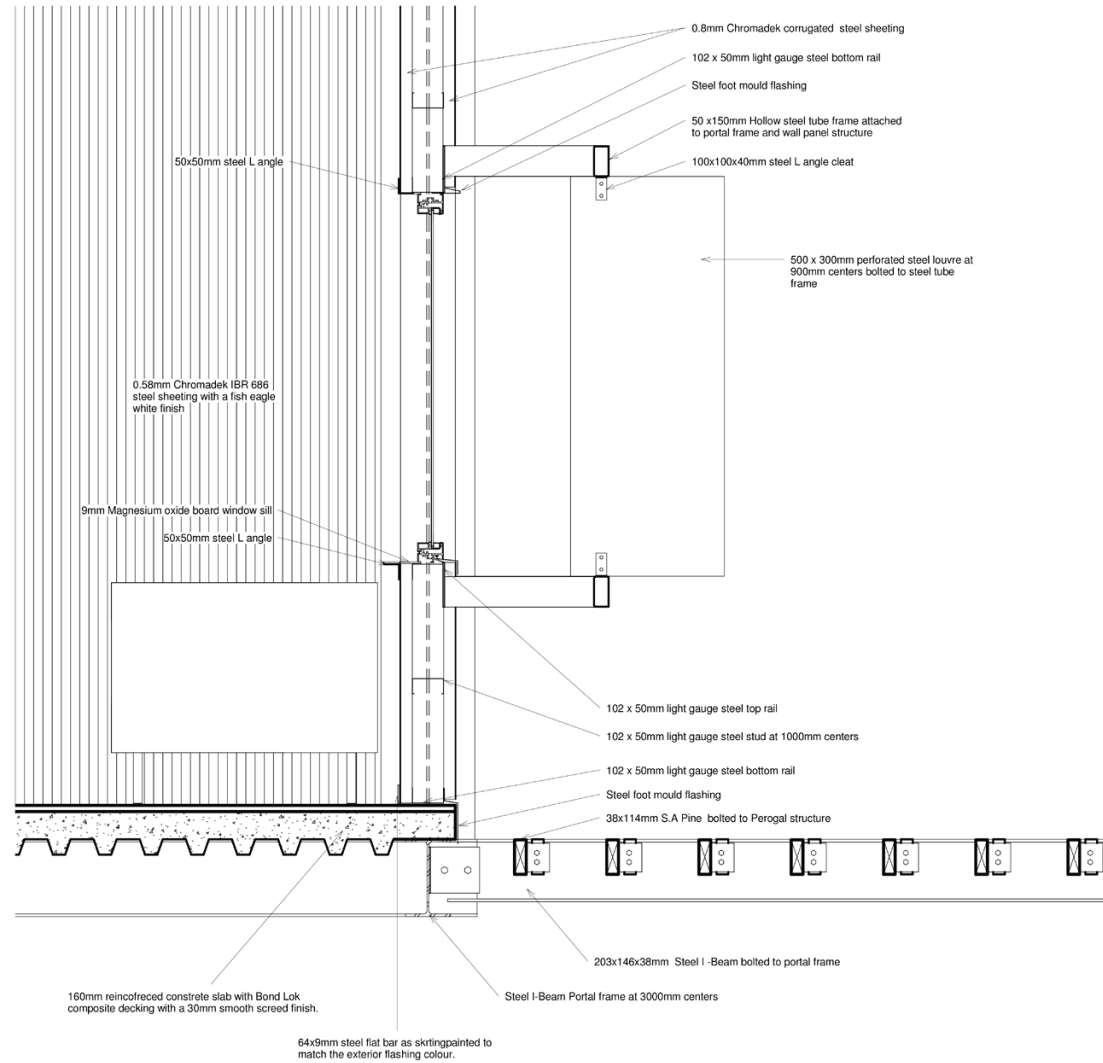

1
SUSPENDED FLOOR DETAIL

Figure 172: Suspended floor detail. 1:10 in presentation (Author 2016).

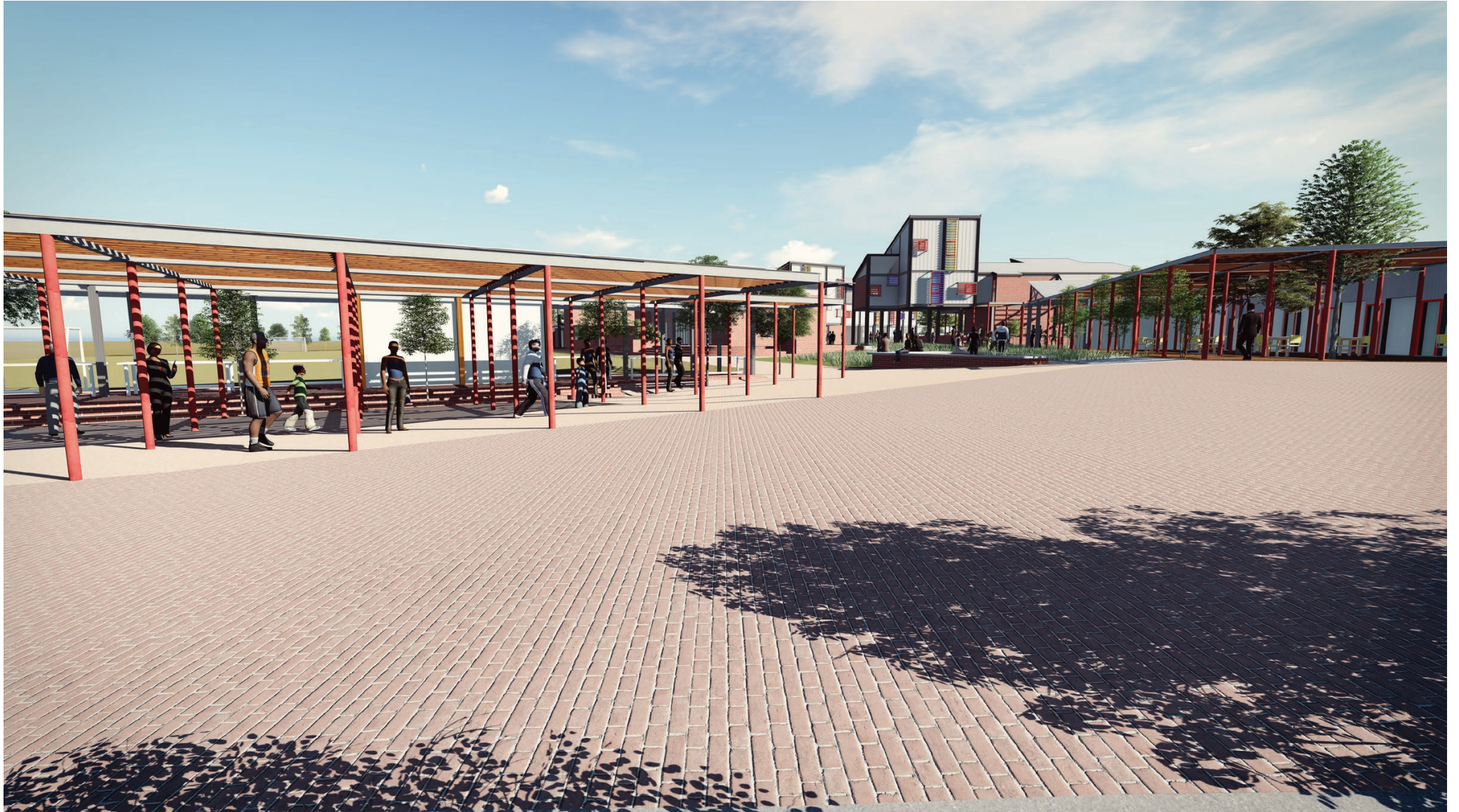

Figure 173:View from the Market Space (Author 2016).

CONCLUSION

The projects' initial intentions have been met and the project has been able to achieve architecture that not only gives access to public amenities but also access to great public spaces. The principles derived and learned in the process show the potential of place making in context similar to Lusaka. The project has been able to reimagine the way in which public amenities are implemented in a community where very few are found. It shows the potential of decentralising public services to a level where the blue collar work of a government entity can be performed by the community members, thereby actively involving them in their health and safety.

In trying to decentralise the public functions, the programme of the project has become too loose to a point where the accommodation list is general leading to an architecture that is open ended. This is both a positive and a negative factor. It allows for the building to be highly adaptable to a point that a completely function could be house the in the building but creates internal conditions that are not specific to the proposed programme. The project does not seek to create an absolute architecture but rather investigate principles that can be employed when designing in a context similar to that found in Lusaka and therefore be able to create an architecture that is appropriate to its social, economic and political contexts.

The understanding of the context and the translation of this understanding into a modular architectural system that can

be used and adapted gives value to an architectural typology that has not been widely used in the township concept. The technical investigation of the project should have occurred concurrently with the design development so that the architectural form could have been investigated more thoroughly so that the potential of the panel system could have been reached.

If Architecture is for the people, has this project achieved the intention of better serving the people in a better space? The project has made a valuable contribution to the architectural field, in a topic that is very relevant in current South Africa. The project has proposed a valid way of intervening in a context like Lusaka and has successfully shown that one is able to create a good neighbourhood where there previously wasn't.

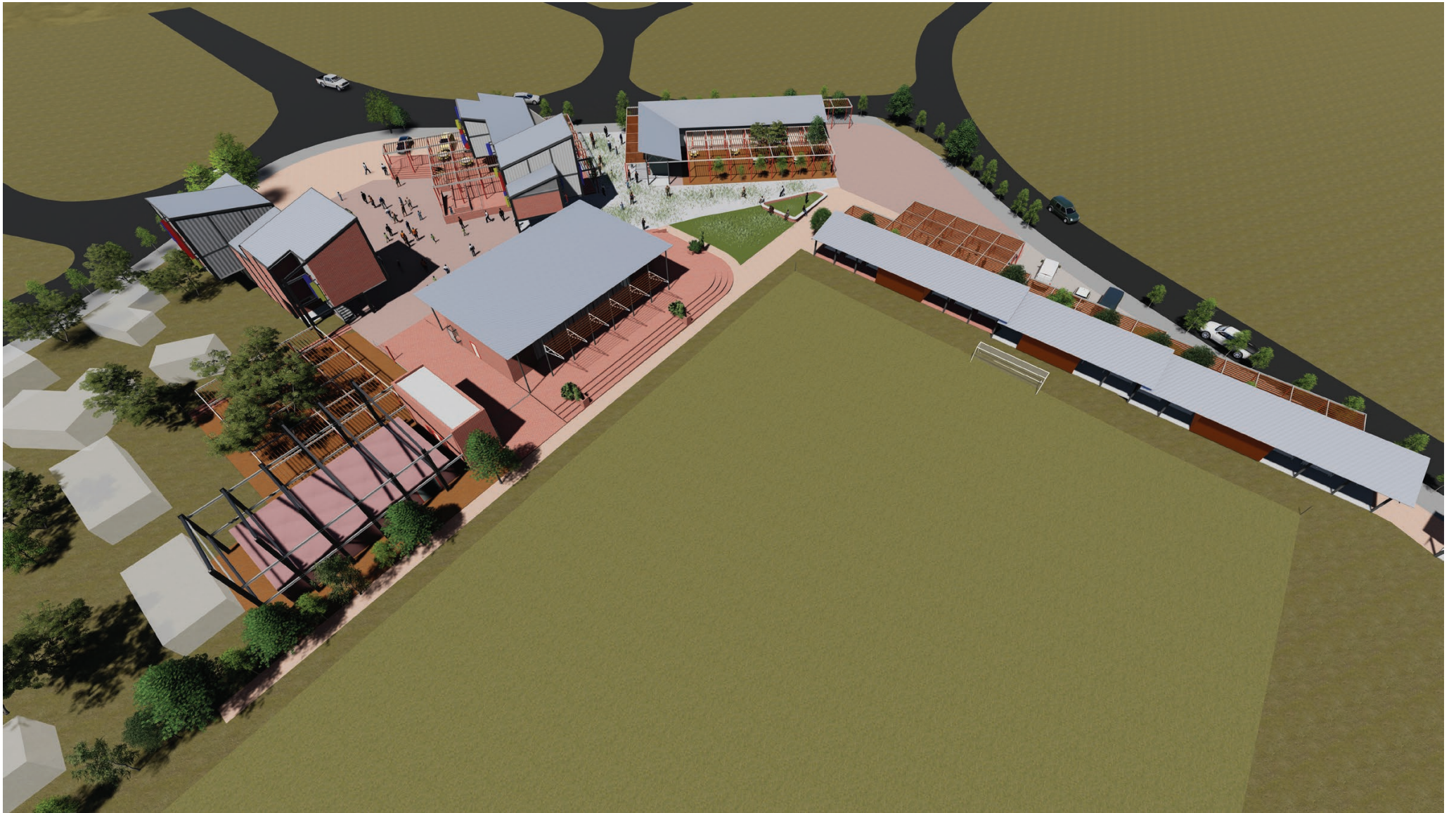

Figure 174: Aerial view of site (Author 2016).