

## A NOVEL COMBINED OTEC/SWRO PLANT

Dyer, D\* and J Ragan  
\*Author for correspondence  
Department of Mechanical Engineering  
Auburn University  
Auburn, Alabama USA  
Email: [ddyer@eng.auburn.edu](mailto:ddyer@eng.auburn.edu)

### ABSTRACT

All actual Ocean Thermal Energy Conversion plants (OTEC) that have been built or designed to date have been at sea level or above. While the concept of OTEC is more than 100 years old, the application has been very limited primarily because of the cost of the plant and the power it produces in comparison to other sources of power. Since OTEC plants are very inefficient (around 3%), huge amounts of low-grade heat must be supplied and rejected. Some authorities estimate that the cost of piping cooling water from some 1000 meters below the ocean surface represents nearly half of the plant cost. The purpose of this paper is to explore the possibility of siting an OTEC plant deep in the ocean and using it to drive a co-located Sea Water Reverse Osmosis Plant (SWRO). A thermodynamic analysis of this system is made to indicate the potential improvement in performance as compared to conventional designs. Data on the performance and cost of conventional plants are used in conjunction with the thermodynamic analysis to give insight into potential advantages of the proposed scheme for the case where it is desired to produce desalinated water. Several advantages are shown to result from employment of this system as compared to conventional technologies including higher efficiency, lower cost, resistance to environmental damage, and improved aesthetics. It is concluded that the potential improvements from submerging an OTEC/SWRO plant, could lead to significant penetration of the technology for this niche situation.

### INTRODUCTION

There are two necessities for the sustenance and sustainability of mankind that are very much intertwined. These necessities are abundant energy and water. Obviously, the goal of mankind is to have a sustainable and cost effective supply of these two elements essential to mankind's existence. This paper deals with two emerging technologies: Ocean Thermal Energy Cycle (OTEC) and Sea Water Reverse Osmosis (SWRO) which have a potential to satisfy these requirements for a sustainable amount of energy and fresh water. The challenge is to develop these technologies that would allow these essential elements to be cost effectively delivered. These two technologies (SWRO and OTEC) are merged into a single, novel system that results in increased efficiency and lower costs for both systems. In other words, neither system would likely be advantageous as compared to its competitor from an economic viewpoint if deployed in a conventional manner separately.

### BACKGROUND

In an earlier paper by the authors [1], a combination Ocean Thermal Energy Cycle (OTEC) plant use to drive a submerged seawater reverse osmosis desalination plant (SWRO) is disclosed. This earlier paper focused on the performance improvement due to submerging a SWRO plant and not on the OTEC plant's potential to improve efficiency and cut costs. Subsequent work by the authors [2] involved determining the optimum operating conditions for the submerged SWRO plant. This study shows that the operating conditions used in reference [1] were not near optimum (in particular the recovery rate defined as the ratio of permeate water to feed water). This paper focuses on the improved efficiency due to driving the submerged SWRO plant with an OTEC plant for the case in which the SWRO plant is operated at optimum conditions.

### CONVENTIONAL OTEC AND SWRO SYSTEMS

In reference (1, 2) by the authors, a complete review of the state of the art for both OTEC and SWRO technologies is presented. In these references it is concluded that a closed cycle OTEC plant and SWRO offer the best solution for providing sustainable, reasonably priced fresh water and power. Schematics of both the closed cycle OTEC plant and the SWRO plant are shown in Figures 1 and 2 respectively. The closed cycle OTEC plant operates on a modified Rankine cycle and utilizes a working fluid like ammonia. Warm sea water is used to evaporate liquid working fluid which is then introduced into a turbine. The turbine exhaust working fluid is condensed by cool sea water. The plant can be used in locations where there is a 20 C or greater ocean temperature difference to give an efficiency of about 3% and an ideal efficiency of about 7%. Typically the cold water must be drawn from a depth of 600 to 1000 meters. The conventional SWRO system draws water from near the ocean surface via a pump. The pump must produce a pressure in excess of the osmotic pressure which is basically proportional to the concentration of salt. The water is first conditioned to remove particulate and then fed through an RO filter. The filter separates the water into two streams: a near pure water stream (the permeate) and a concentrated waste stream. The recovery rate defined as the ratio of permeate to raw water input can be controlled. However, increasing this ratio results in increasing the concentration of the water, the osmotic pressure, the pump required discharge pressure, and the power that must be delivered to the pump. There is so much energy in the waste

stream that an energy recovery turbine must be used to capture its energy and used to supply some of the required power to the pump. It turns out that the optimum recovery ratio for a conventional SWRO is about 50% because the size and cost of the recovery turbine outweighs the value of increased permeate due to further increasing the recovery ratio.

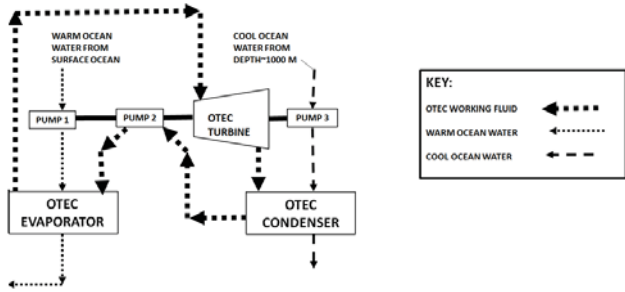

Figure 1. Conventional OTEC System

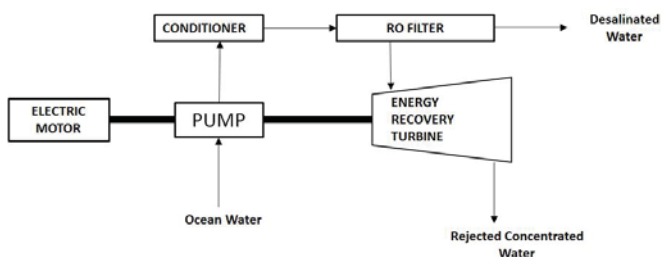

Figure 2. Conventional SWRO System

**COMBINED UNCONVENTIONAL OTEC AND SWRO SYSTEM**

The unconventional OTEC/SWRO system is shown in Figure 3. This system represents the concept that is being studied in this paper. As shown in Figure 3 the system is submerged to a depth of approximately 600 to 1000 meters. In the proposed unconventional OTEC system it is proposed to locate the evaporator in the warm sea water near the ocean surface and the condenser in the cool water at 600 to 1000 meters. This eliminates the need to pump water through pipes while using the flow of refrigerant to span the 600 to 1000 meters. The advantage of this idea is that the diameter of piping for water will be at least 3 times the diameter of piping for refrigerant. A potential disadvantage is that the OTEC piping between the evaporator and turbine will be under external pressure and must be robust enough to prevent collapse by buckling. In the submerged OTEC system, the warm water is drawn through a duct by pump 1 from near ocean surface and is used to evaporate its working fluid. The warm water pump 1 basically must overcome the friction in the evaporator and would be powered by an electrical supply from ocean surface. The cool water for the system is pumped directly from the system surroundings through the condenser. One advantage is that piping to connect the plant to shore for both the OTEC and SWRO plants is eliminated by the unconventional system. Another major difference between the conventional and unconventional plants is that the unconventional plant does not require electric generation, electric transmission, and an electric motor to drive all the pumps with the exception of pump 1. As shown in Figure 3, direct mechanical

transmission of power to all the other pumps with the exception of pump 1 is used. It is also shown in Figure 3, that no energy recovery turbine in the SWRO plant is required because the waste stream is at nearly the same pressure level as the ocean at the plant depth. This allows the SWRO plant to be operated with a recovery rate of less than 5% which is shown to be the optimum in reference (2). Another change from the conventional SWRO plant is the use of two pumps as shown in Figure (3). The upstream pump 4 must provide just enough pressure to overcome the friction in the RO filter since the ocean water pressure is already above the osmotic pressure. The downstream pump 5 must maintain the difference between the supply pressure to the RO filter and the permeate discharge pressure slightly greater than the osmotic pressure.

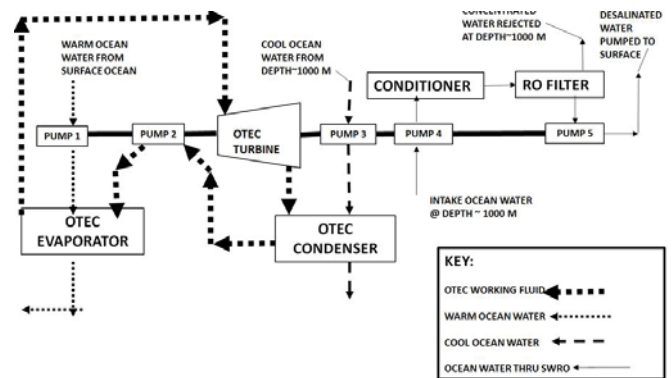

Figure 3. Combined Unconventional OTEC/SWRO Plant

**EXAMPLE ILLUSTRATING ADVANTAGE OF PROPOSED UNCONVENTIONAL SYSTEM**

To delineate the advantages of the proposed unconventional system over the conventional OTEC/SWRO plant, reference (3) is used as base line data for a conventional, land-based OTEC plant. Figure 4 gives the basic operating design and parameters for the plant considered in reference (3). Table 1 gives the detailed fluid properties at each point in the system. The advantages of the proposed system will be considered first by exploring the savings due to the unconventional OTEC system followed by the unconventional SWRO system.

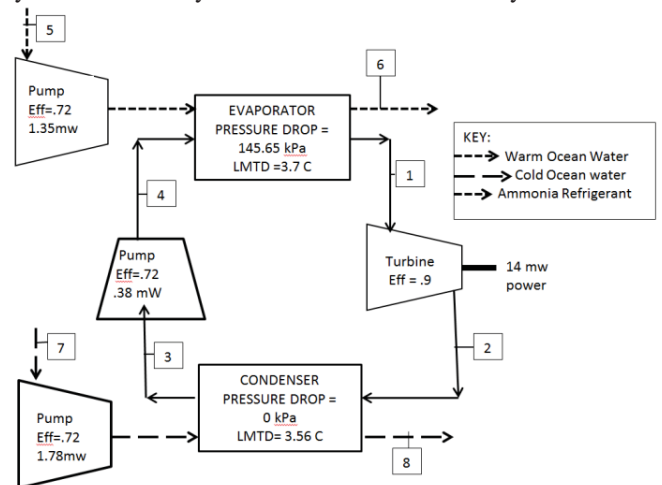

Figure 4. Schematic of Baseline OTEC

**Table 1. State properties for Base Case**

State	T,C	P,kPa	v,m <sup>3</sup> /kg	x	h,kJ/kg	Q,m <sup>3</sup> /s
1	21.1	889.35	0.14458	1	1460.93	44.24
2	10	615	0.1421	0.9859	1444	43.48
3	10	615	0.0016	0	226.75	0.4896
4	14.33	1035	0.0016	0	246.96	0.4896
5	26.6	p6-28.4	0.000974	0	106.96	33.75
6	24.39	p6-28.4	0.000974	0	98.03	23.75
7	4.4	p7	0.000974	0	17.4	31.17
8	7.88	p7-24.8	0.000974	0	31.42	31.17

**Key Table 1:**

**T=Temperature, P=absolute Pressure, v=specific volume, x=quality as decimal fraction, h=enthalpy, Q= volume flow rate, States are defined in Figure 4.**

**Savings Due to Reducing OTEC Evaporator Pumping Requirement**

The unconventional design of the OTEC evaporator does not require pumping of water to a remote spot but only a pump to overcome the actual pressure drop in the evaporator. This pumping power is the product of the volume flow rate and pressure drop divided by pump efficiency. Using the values from the base case (Table 1) gives

$$\text{Evaporator Pumping power} = 33.75 \text{ m}^3/\text{s} \times 28.4 \text{ kPa} / 0.72 = 1.33 \text{ mw}$$

For the base case the pumping power is 1.35 mw. The potential savings is small (.02 mw) since the line distances for the evaporator are small due to fact evaporator is located near ocean surface for the base and unconventional case.

**Savings Due to Reducing OTEC Condenser Pumping Requirement**

The unconventional design of the OTEC condenser does not require pumping of water to a remote spot but only a pump to overcome the actual pressure drop in the evaporator. This pumping power is the product of the volume flow rate and pressure drop divided by pump efficiency

$$\text{Condenser Pumping power} = 31.17 \text{ m}^3/\text{s} \times 24.8 \text{ kPa} / 0.72 = 1.074 \text{ mw}$$

For the base case the condenser pumping power is 1.78 mw. Hence, the unconventional design saves  $1.78 - 1.07 = .71$  mw

**Hardware Savings Due to Placement of OTEC Condenser at Depth 1000m**

The pressure drop from the outlet of the evaporator to the turbine entrance for the base case (Table 1) is 889.35kPa - 615 kPa = 174.35 kPa. Using the calculator from reference (4) shows that the pressure drop in a 1000 m long pipe of 1 meter diameter gives this same pressure drop. Hence, the required pipe diameter for providing a conduit from the evaporator to the turbine inlet for the unconventional OTEC system is approximately 1 meter. The pressure loss assumed for the base case in the cold water pipe is 16 kPa. In order to achieve the same pressure drop as used in the base case, the cold water

pipe diameter using the calculator from (5) must be 3.4 meters. Hence, using the unconventional OTEC system reduces the required pipe diameter from 3.4 meters to 1 meter. Another advantage is that one does not have to deal with fouling since the ammonia pipe is a closed system containing ammonia.

**Savings Due to Using Direct Drive for Unconventional OTEC**

The conventional OTEC system must provide pumping power by generating electricity and then supplying power to electric motors while the unconventional OTEC system can power the cold water pump and ammonia pump by direct drive. Typically this conversion to electric power and then to power via an electric motor will result in a 10% loss. The base case cold water pump and ammonia pump consume a total of 2.46 mw (Figure 4). Hence, the savings from the conventional system would be 10% of this amount or .25 mw.

**Savings Due to Combining an Unconventional OTEC with Unconventional SWRO**

The net power delivered to the unconventional SWRO from an unconventional OTEC can be increased by 10% as described previously due to utilizing a direct drive. The base case OTEC produces 10 mw (Figure 4), so that 1 mw more power can be delivered to the unconventional SWRO by utilizing direct drive.

**Savings Due to Enhanced Performance of Unconventional SWRO**

Reference (2) shows that the unconventional SWRO reduces the power requirements for a single stage conventional SWRO system is 7.4 kJ/kg while the unconventional SWRO system described above uses 4.5 kJ/kg. Hence, the unconventional SWRO reduces energy use by about 39% or, from another view, one can produce 39% more fresh water with the same power by utilizing the unconventional SWRO system.

An additional savings of energy of typically 10% is also gained by the unconventional system by using direct drives to power the pumps in the SWRO system. Hence, the overall energy savings in the SWRO system is 1.1 times 39% or approximately 43%.

**CONCLUSIONS**

This paper describes two innovations in hardware involving OTEC and SWRO systems. The novel OTEC system described involves immersing the entire system in the ocean and further eliminates the use of cold water piping by placing the OTEC condenser at approximately 1000 meters depth while placing the OTEC evaporator near the ocean surface. The SWRO system is also immersed in the ocean at approximately 1000 meters and is directly driven by the OTEC system. The SWRO system is optimized by using a very low recovery rate (order of 5%)

The novel system provides many advantages over conventional systems that have been built. Some of the important advantages are enumerated as follows:

- The amount of power that must be input into the OTEC condenser and evaporator water pumps is decreased by .73 mw for a 10 mw OTEC plant.
  - The amount of power lost in generating electricity and then driving the OTEC pumps by electric motors is reduced by .25 mw for a 10 mw OTEC plant.
  - The decrease in power consumption for items 1 and 2 increases the OTEC efficiency from 2.17% to an efficiency of 2.4 % but, more importantly, the power output for the same size unit increases by about 10%.
  - The cold water pipe with a diameter of 3.4 meters is eliminated by adding the same length of refrigerant pipe (from evaporator to turbine in the OTEC) that is 1 meter in diameter.
  - The submerged system would not be affected by hurricanes/tsunamis.
  - The plant would not provide visual pollution.
- More than 43% more water could be produced by the SWRO plant as compared to a conventional plant.

#### LIST OF REFERENCES

1. Ragan, J.S., Dyer, D.F., "Novel Reverse Osmosis Desalination of Sea Water", Sustainable Irrigation and Drainage IV, Transactions pp. 195-202, 2012
2. Ragan, J.S. Submerged Reverse Osmosis Desalination, Dissertation, Auburn University, Department of Mechanical Engineering, August 2014
3. Ocean Thermal Energy conversion (OTEC), Power Systems Development Preliminary Design Report, Final, Dec 4, 1978, Contract No EG=77=CV-03-1570, TRW Systems and Energy, Redondo Beach, CA
4. <http://www.globalspec.com/calculators/loss-in-straight-gas-lines>
5. <http://www.druckverlust.de/Online-Rechner/dp.php>