

CHAPTER 6



© University of Pretoria

DESIGN

TOWARDS ARCHITECTURE

Design process

*The subjective intimate city meets the
objective universal city*

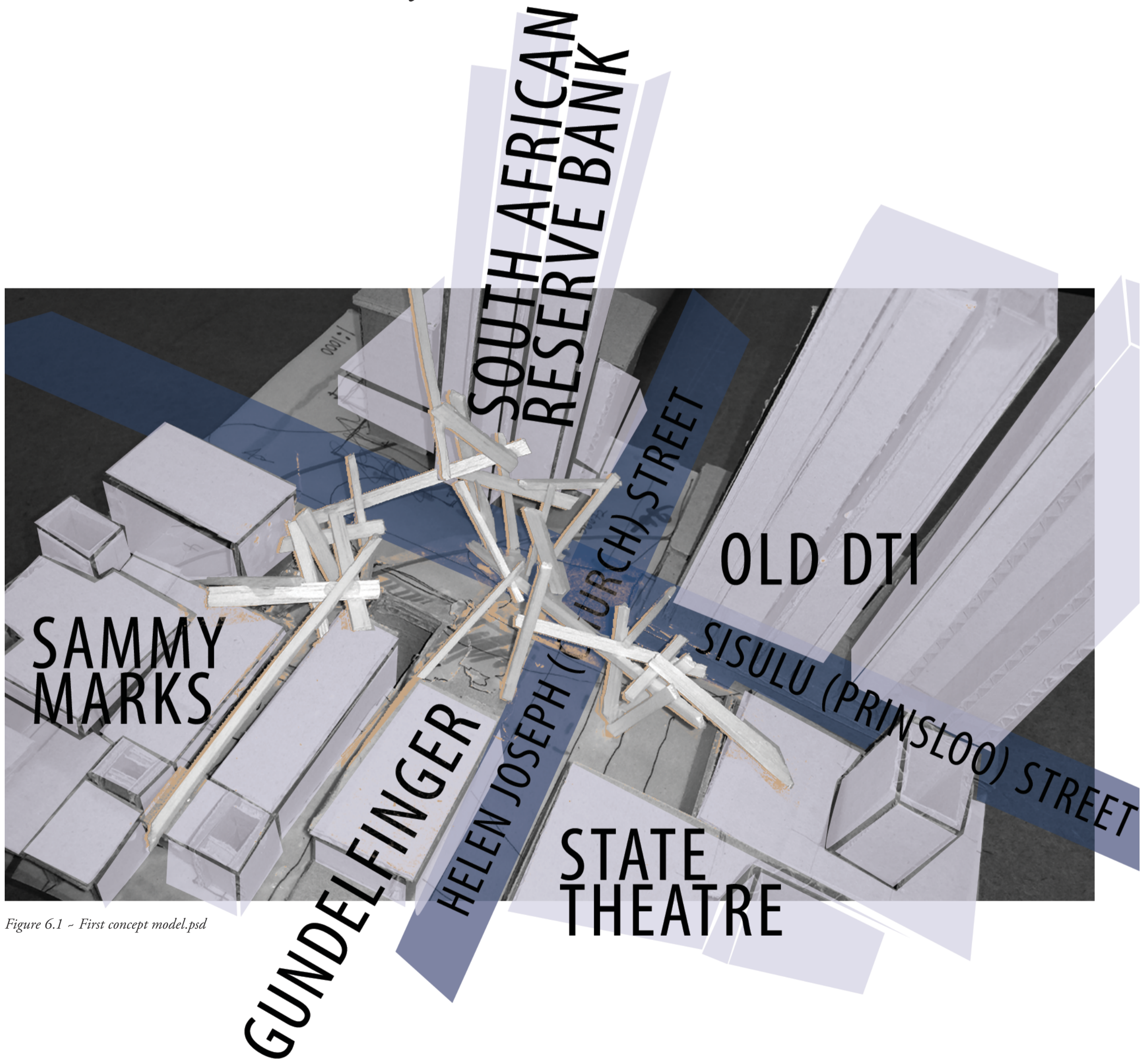

Figure 6.1 - First concept model.psd

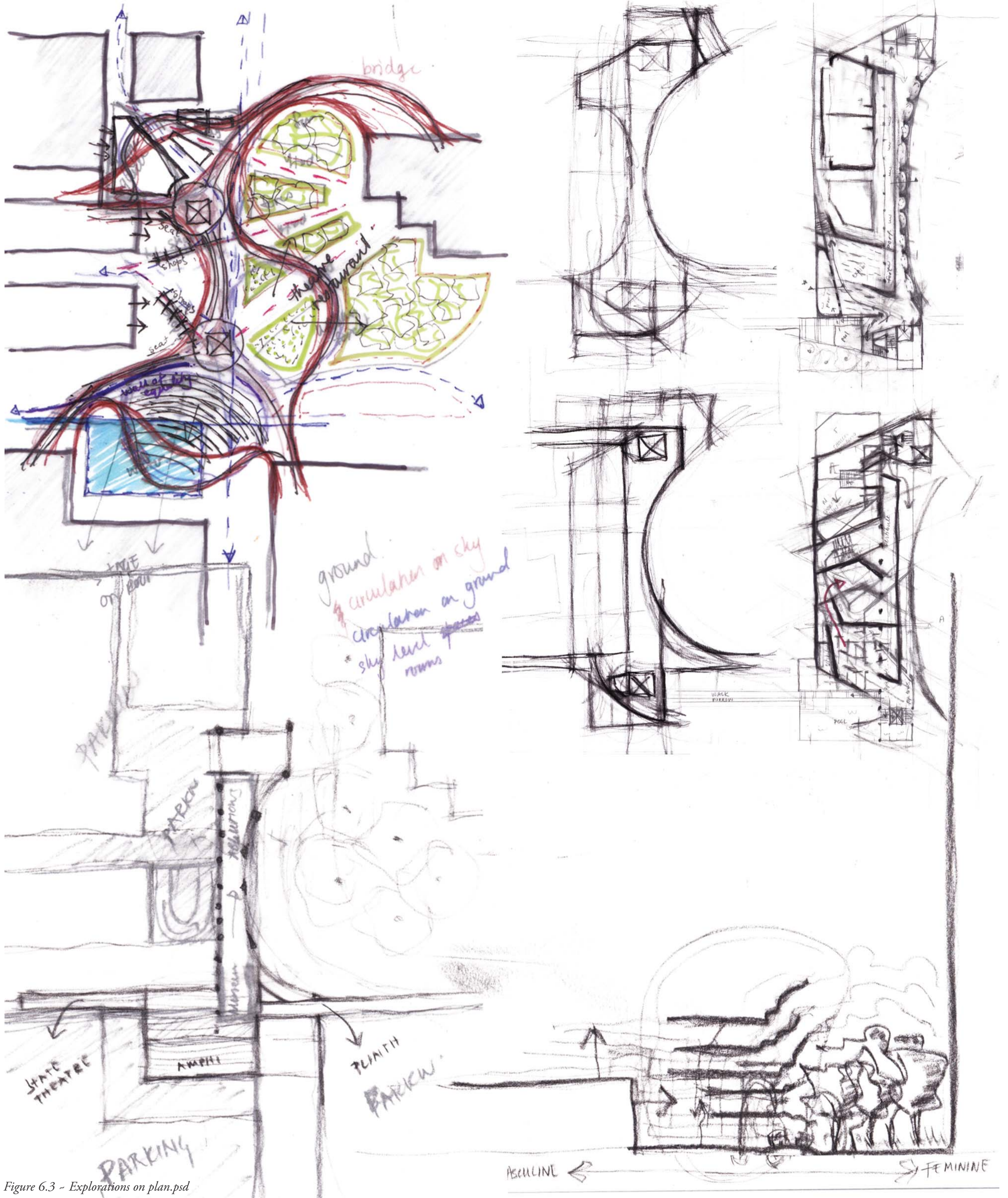

Figure 6.3 - Explorations on plan.psd

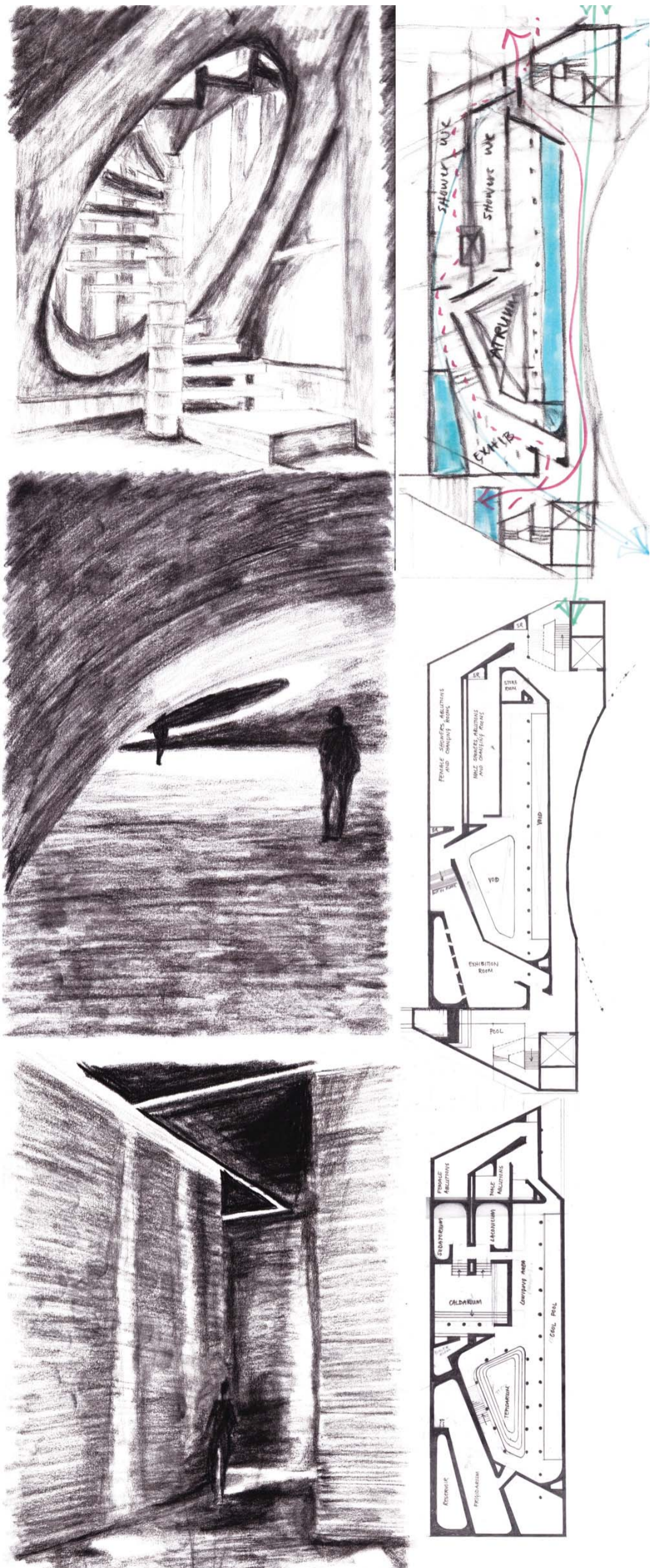

Figure 6.4 - Spatial inspiration drawing and concept underground bath house plans.psd

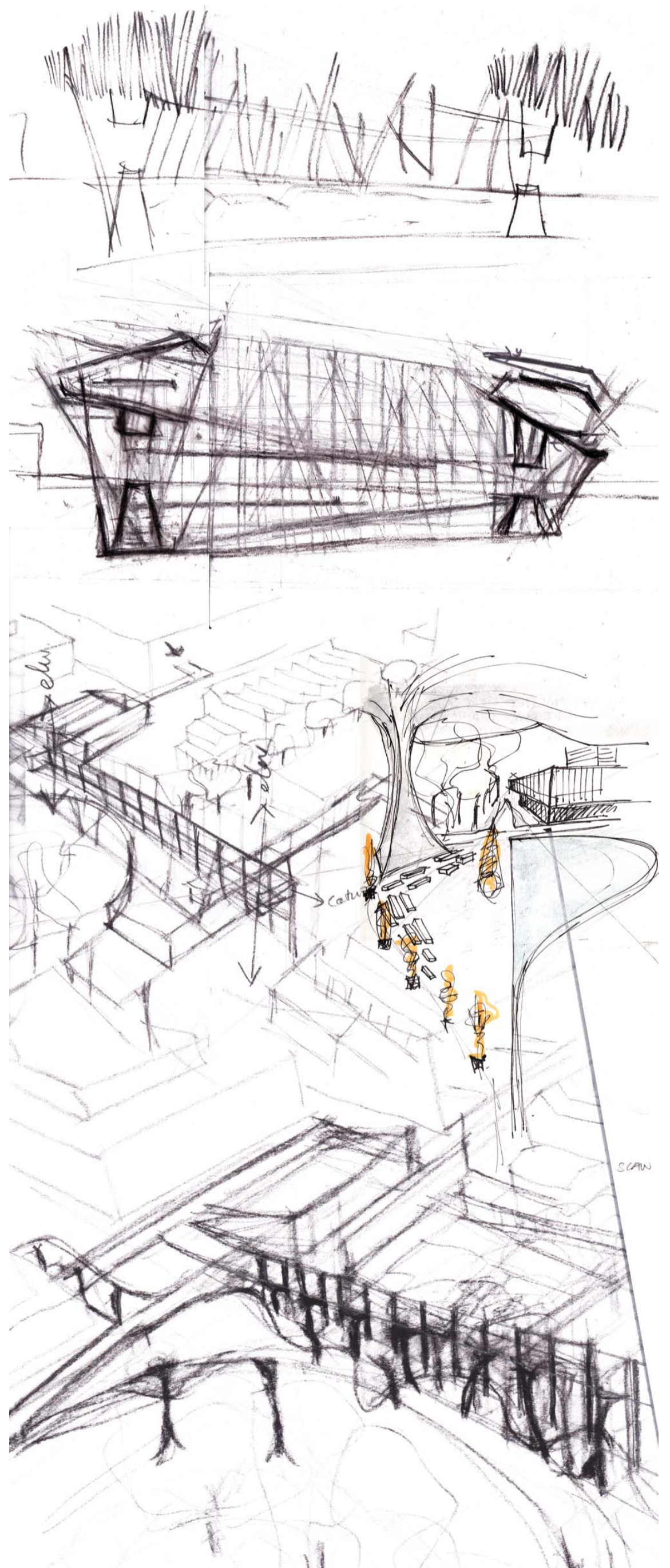

Figure 6.5 - Concept development of section on site.psd

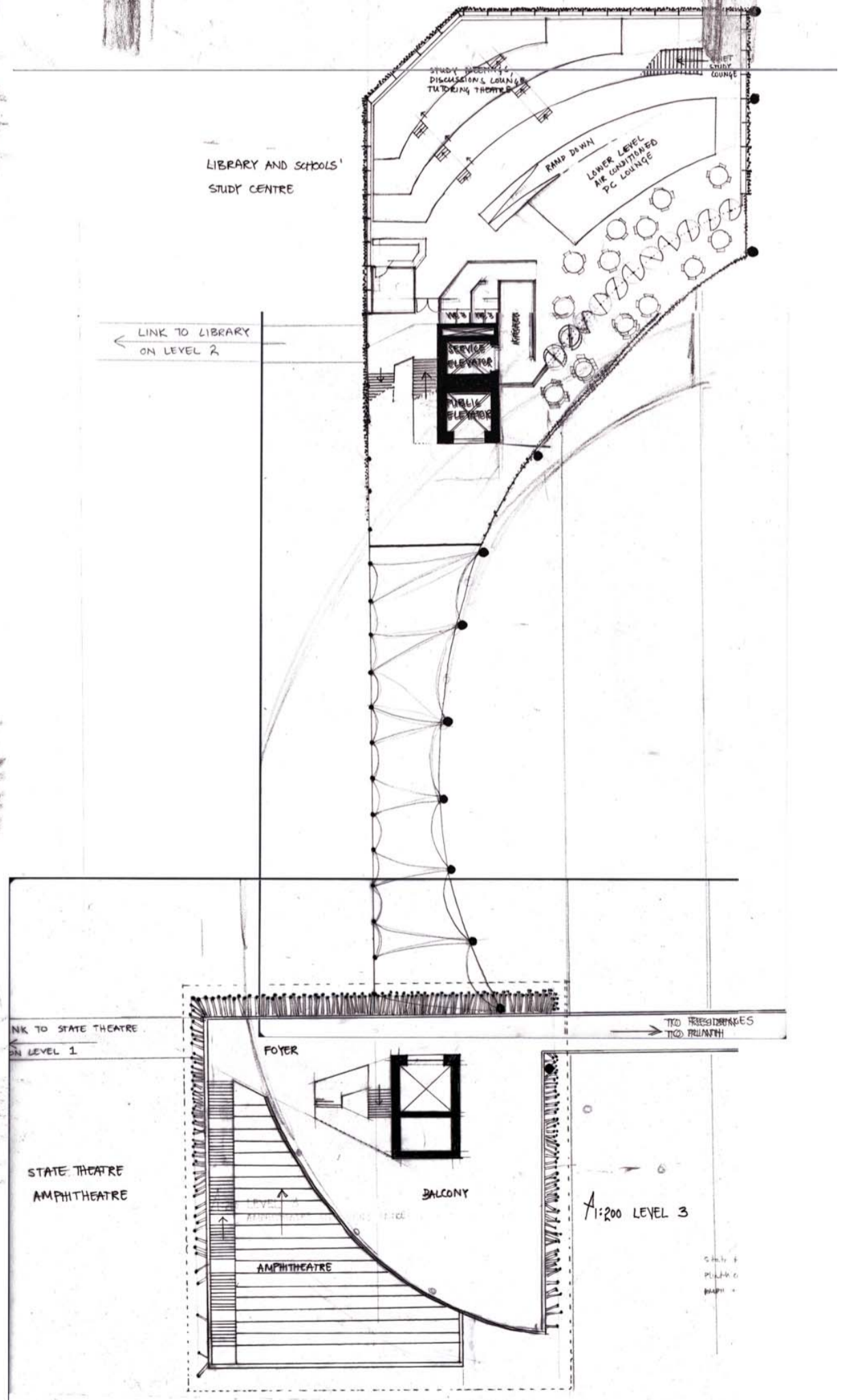
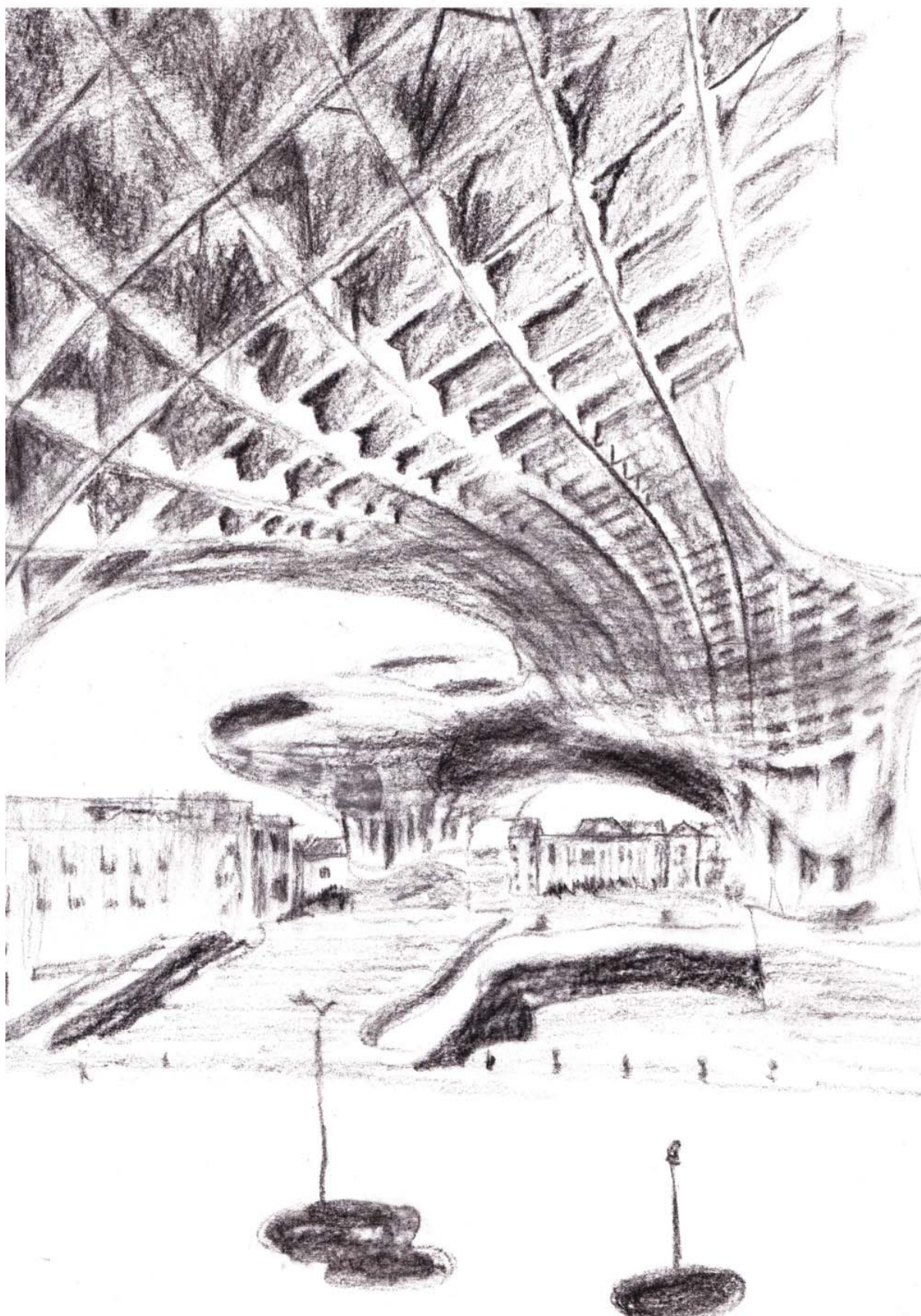
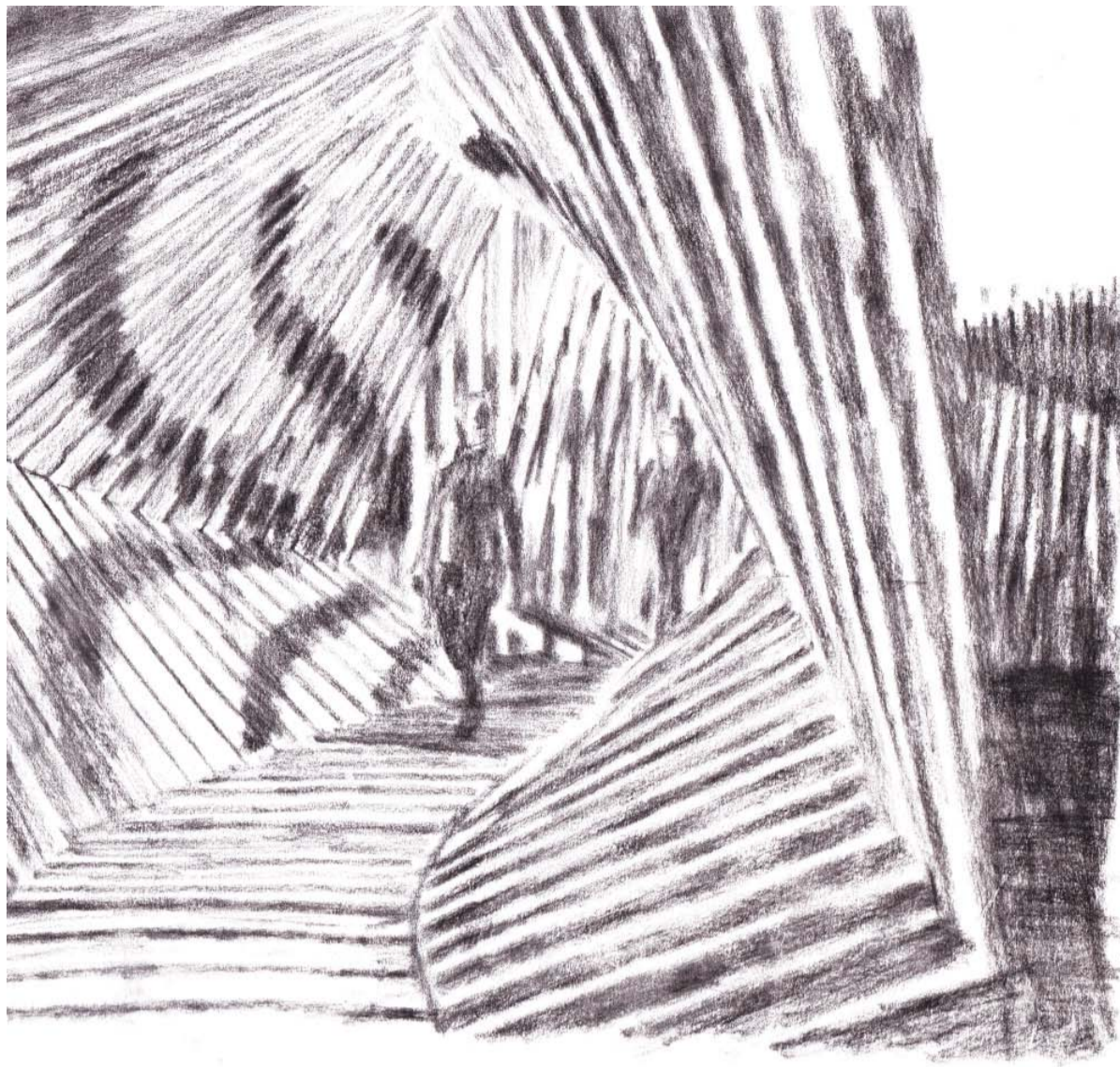

Figure 6.6 - Spatial inspiration drawings and concept plan for sky arcade top floor.psd

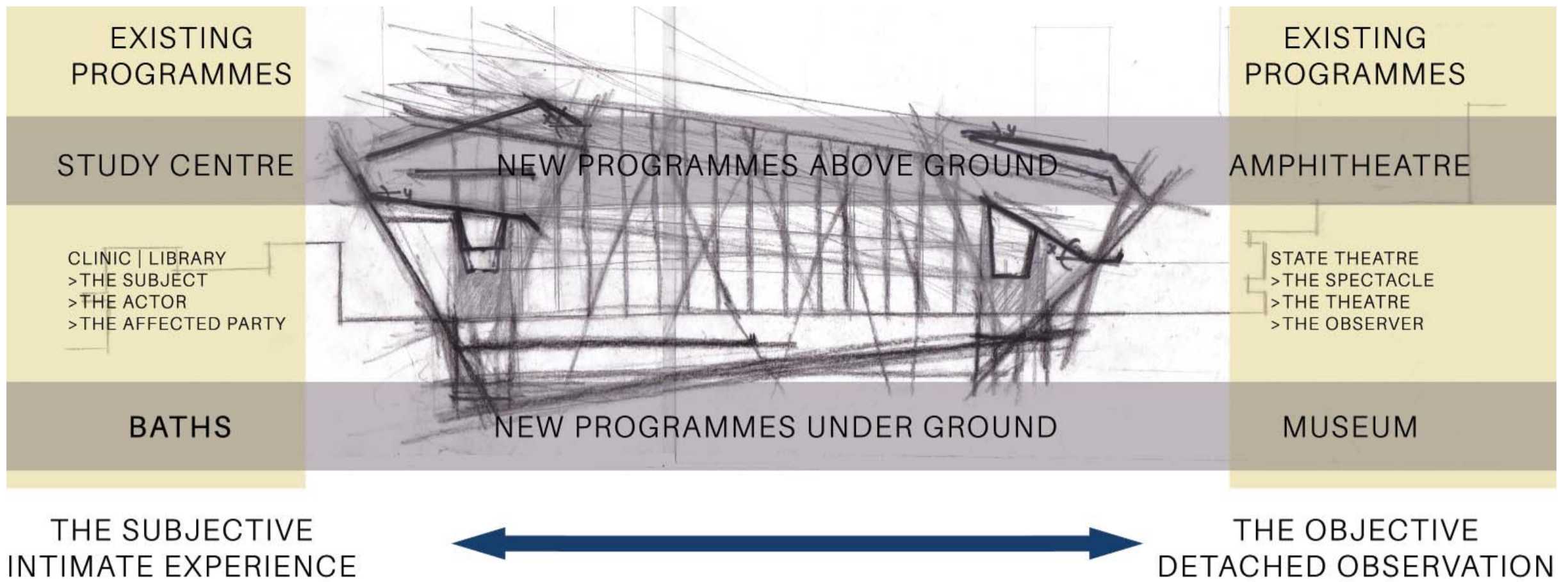

Figure 6.8 - Concept section diagram - Structure as mediator between the objective observation and subjective experience.psd

At this point water, the water furrows and programmes supported by water (a bath house) became the medium between the all the disconnected programmes and buildings. Water was the connector.

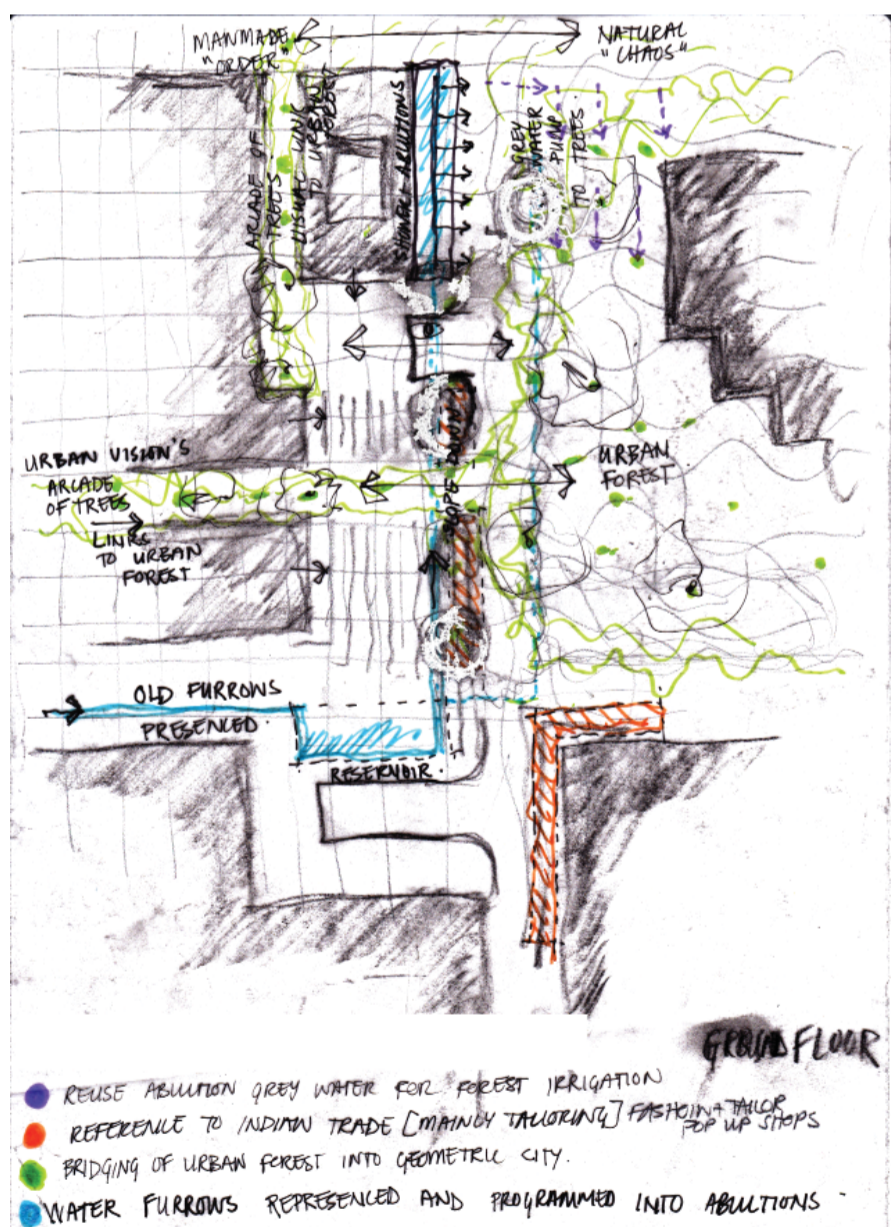

Figure 6.7 - Design intention on plan.psd

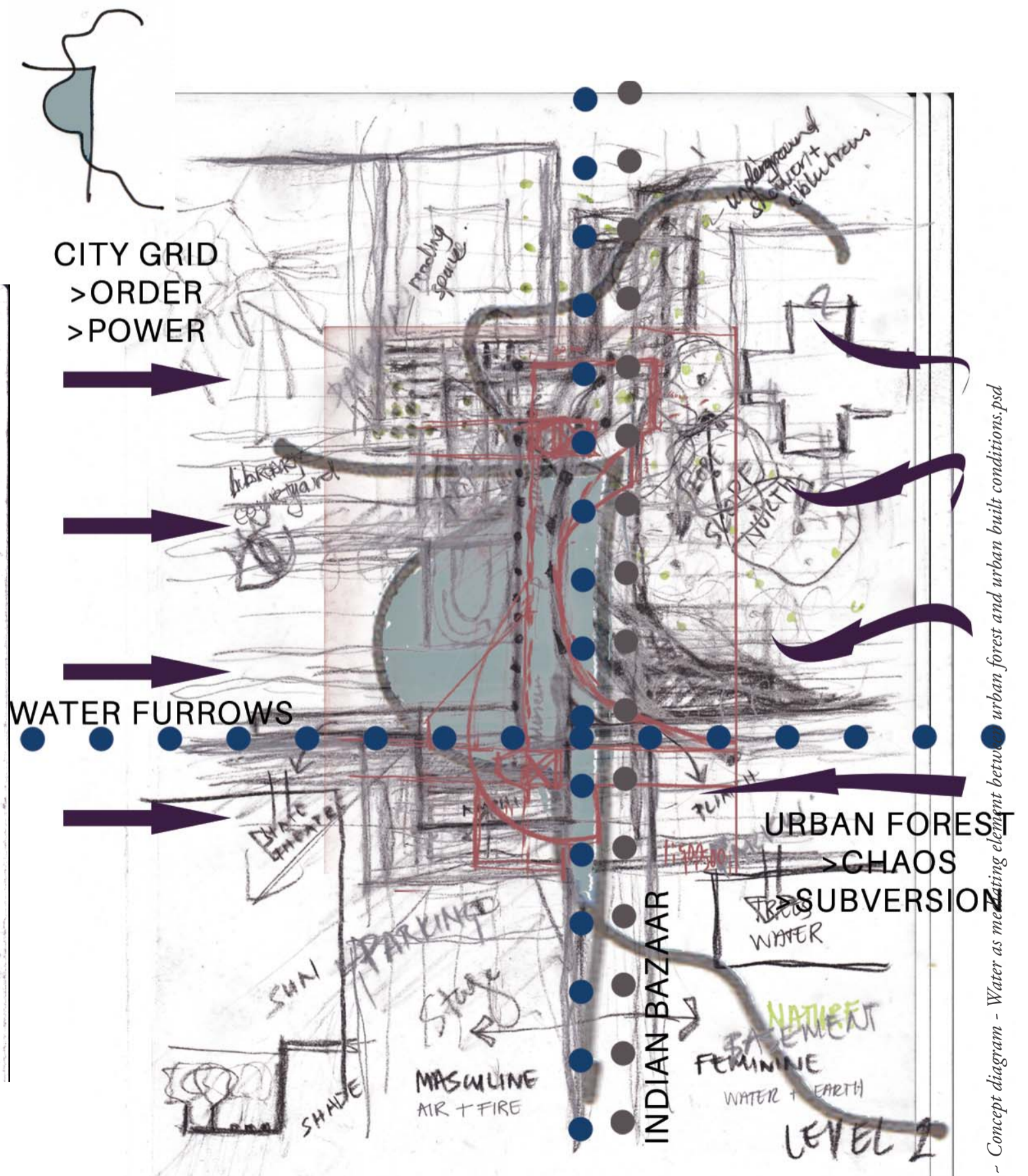

Figure 6.9 - Concept diagram - Water as mediating element between urban forest and urban built conditions.psd

New perceptions of the city are created through new architectural experiences

New architectural experiences:

- >contest the existing biased representations of history
- >merges existing programmes and buildings
- >re-present the historic narratives
- >and accentuates the arcades systems

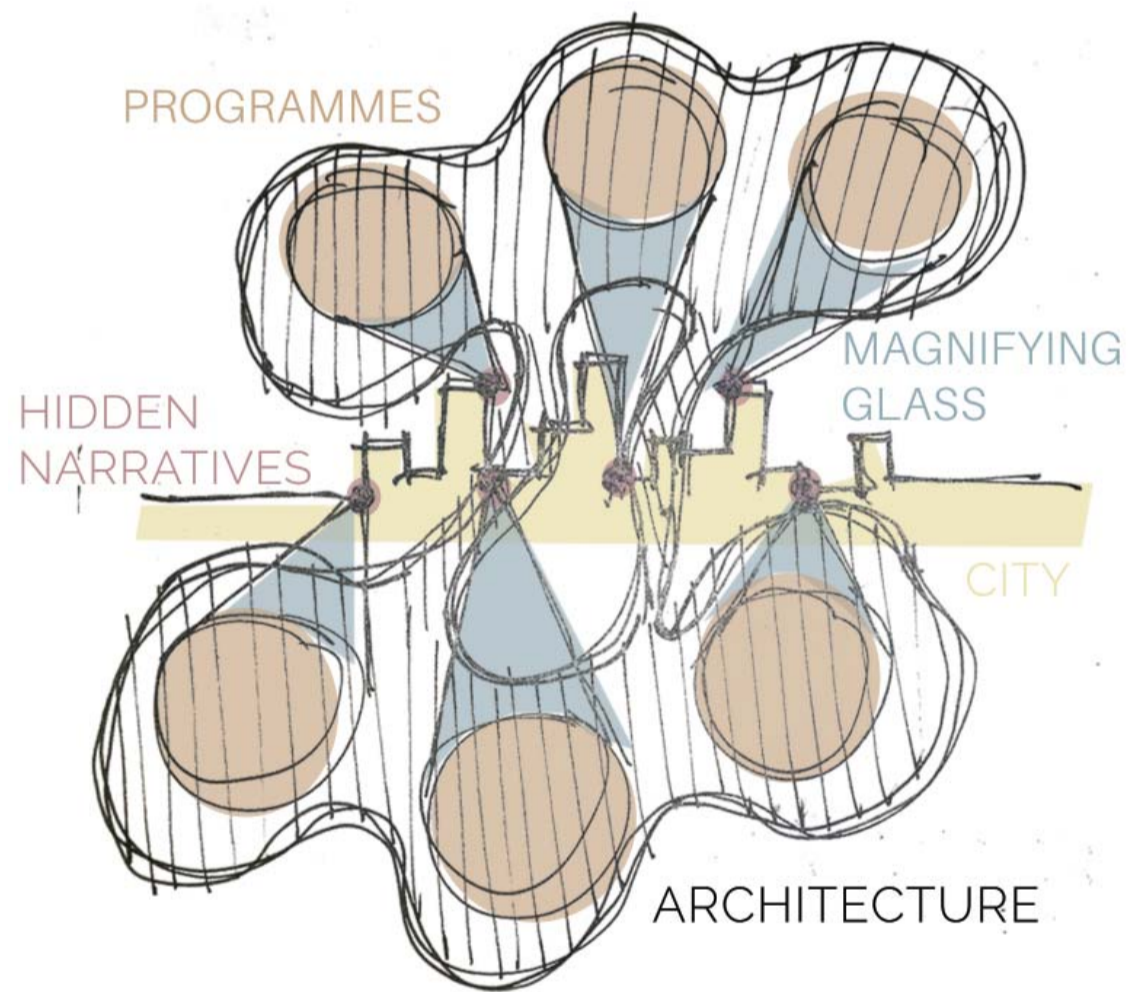

Figure 6.10 - Concept diagram - Represente the site's hidden narratives.psd

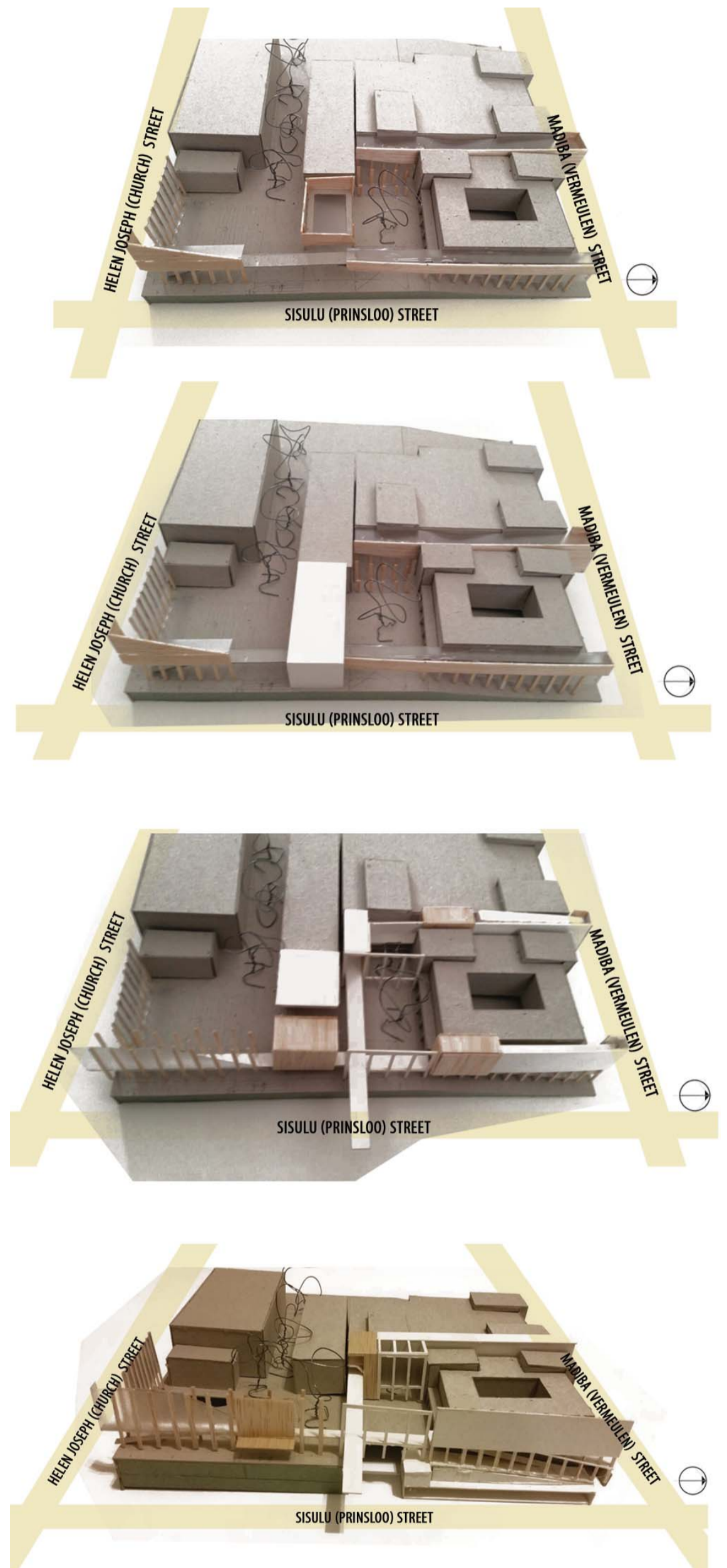
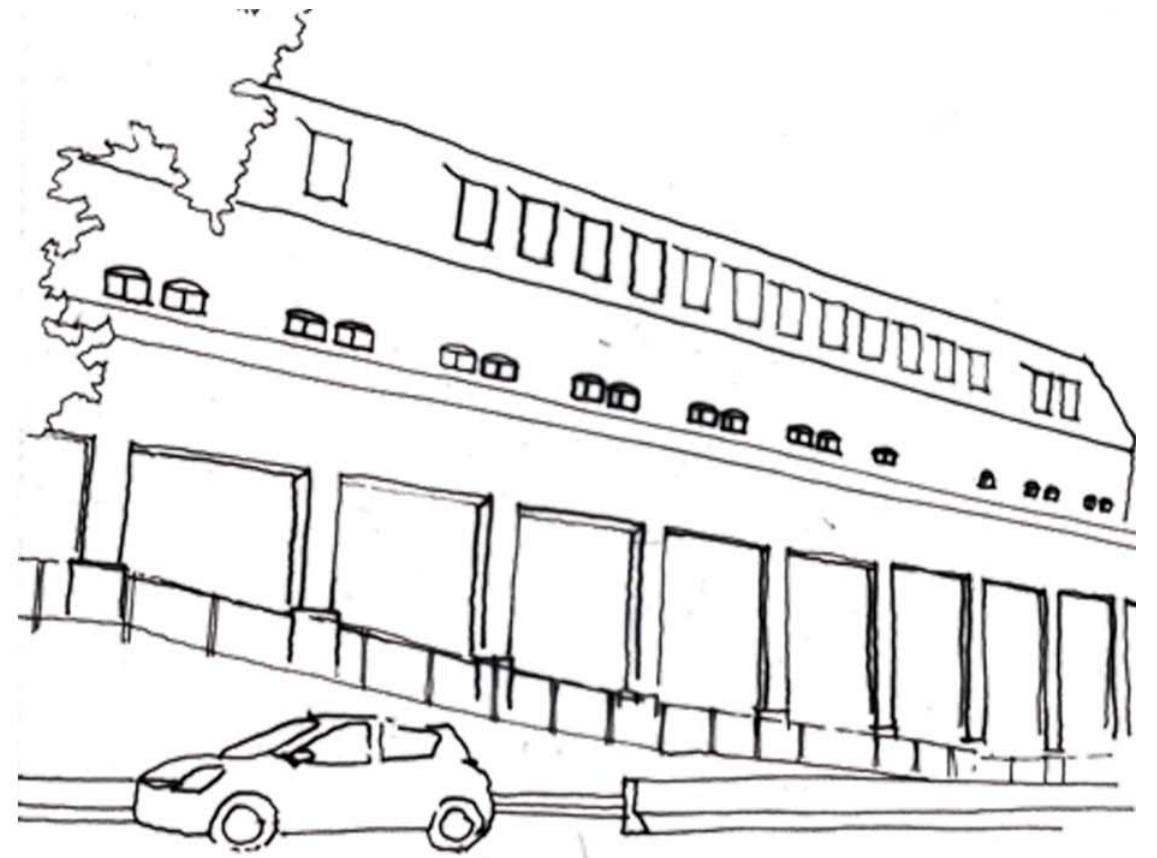

Figure 6.11 - Model explorations.psd



Colonnaded 'Stoep'

WHY? STOEP?

COLONNADE

HISTORICAL

PRETORIA
STOEP

INTERMEDIARY
SPACE

CURRENT

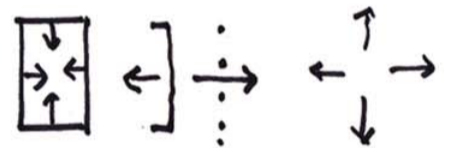

INSIDE THRESHOLD 'STOEP' OUTSIDE



WHY STEEL?

COLONNADE



MASS ON
SITE

JUXTAPOSE
WITH



JUXTAPOSITION



JUXTAPOSITION

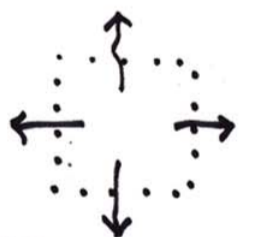

WHY STEEL STRUCTURE?

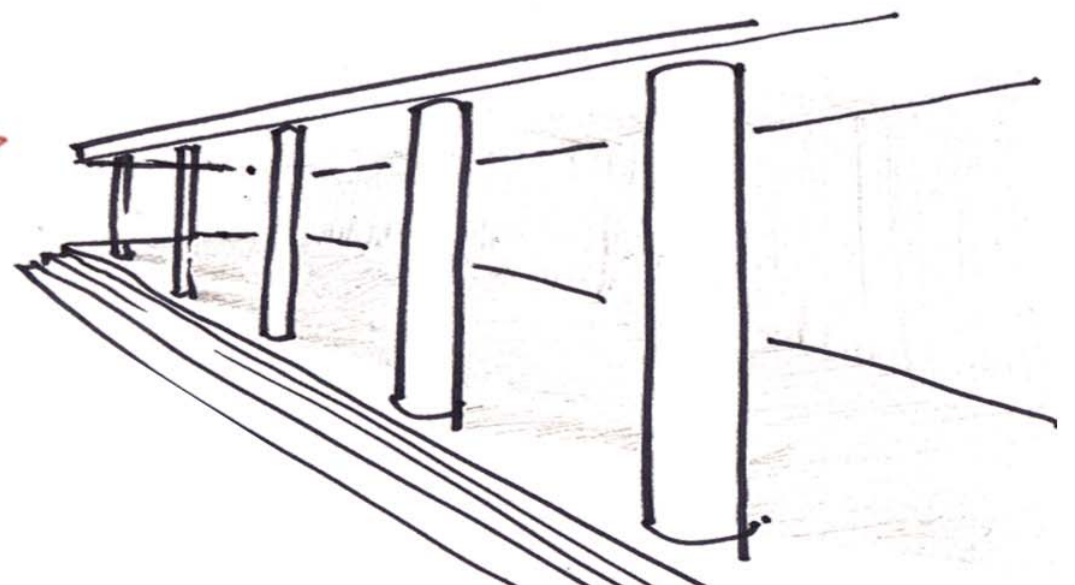
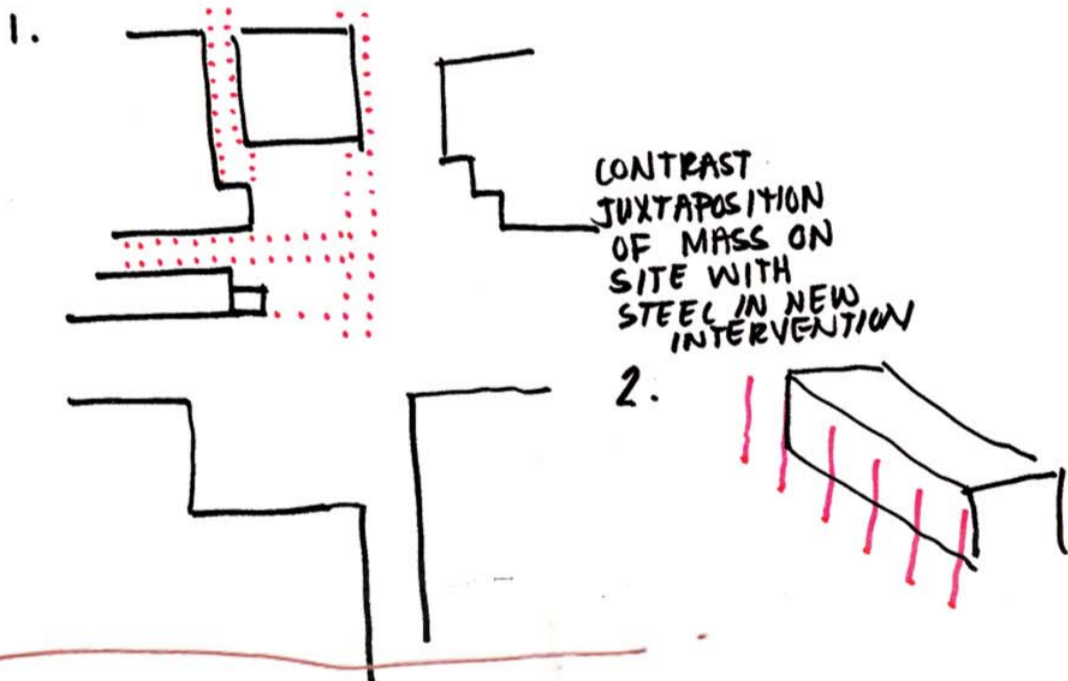

Figure 6.12 - Justification for colonnaded stoep typology.psd

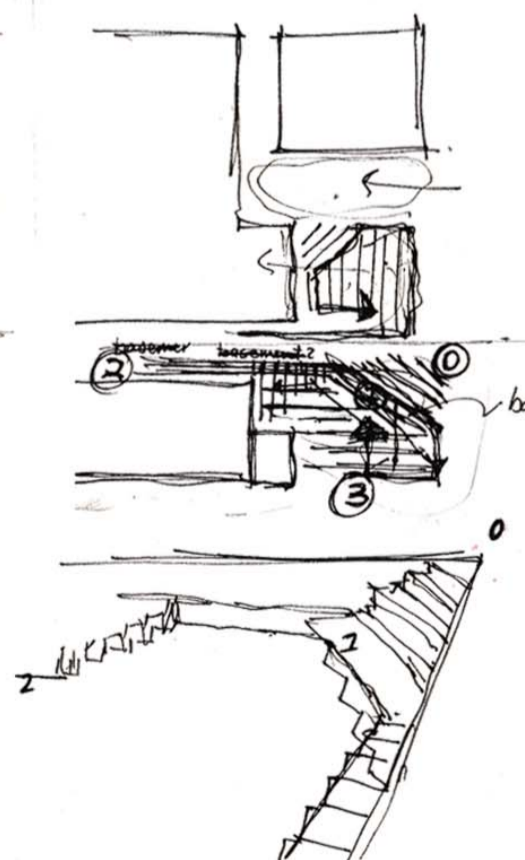
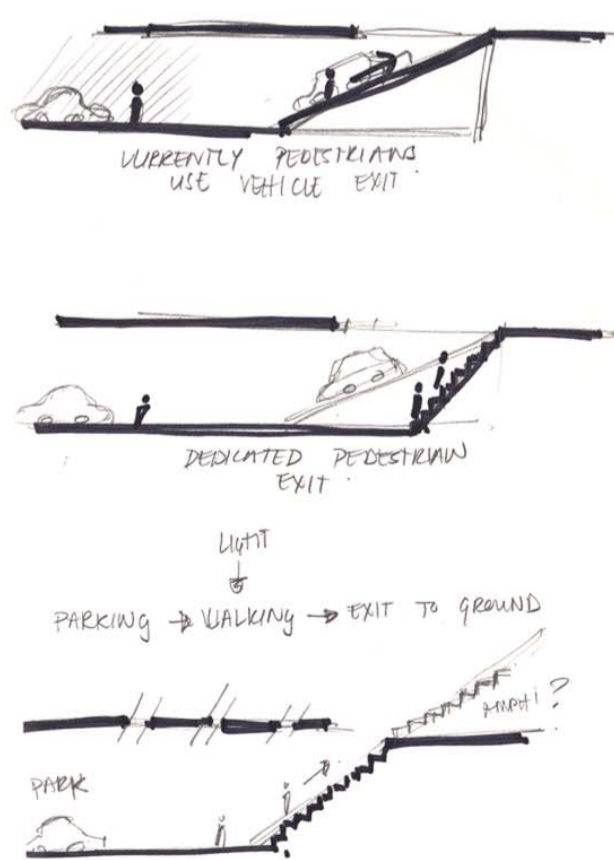
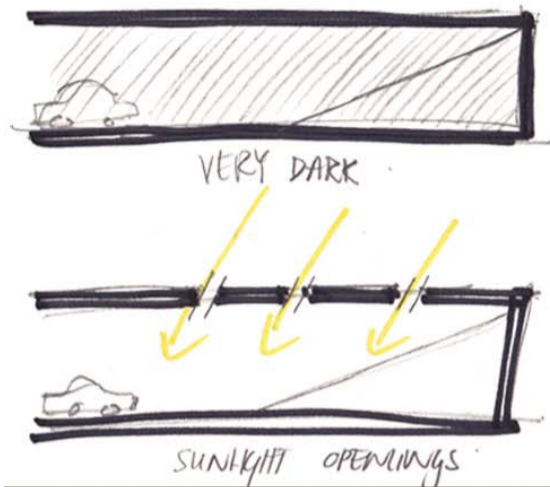

Figure 6.13 - Explorations for illuminating the basement.psd

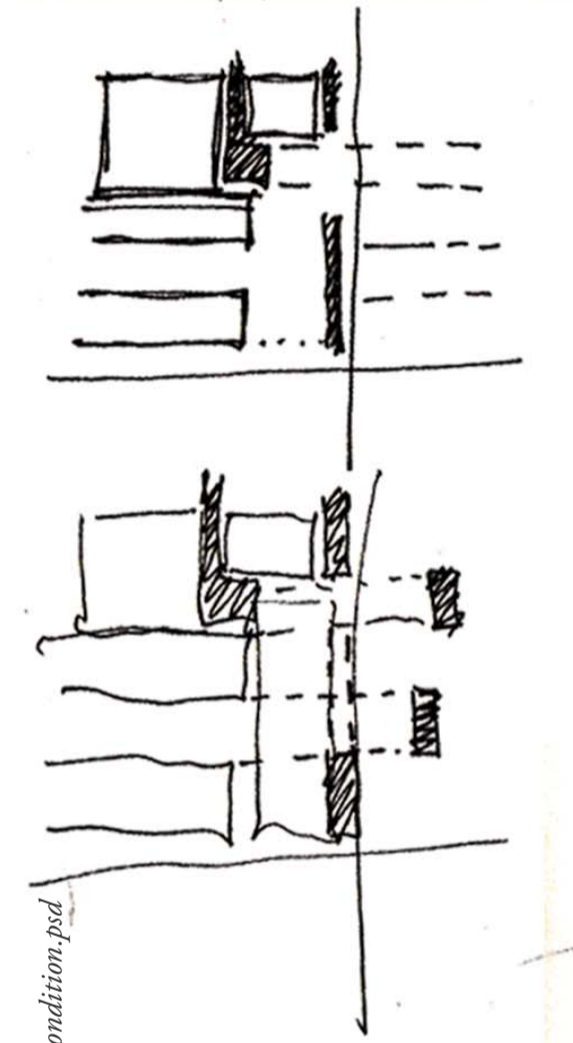
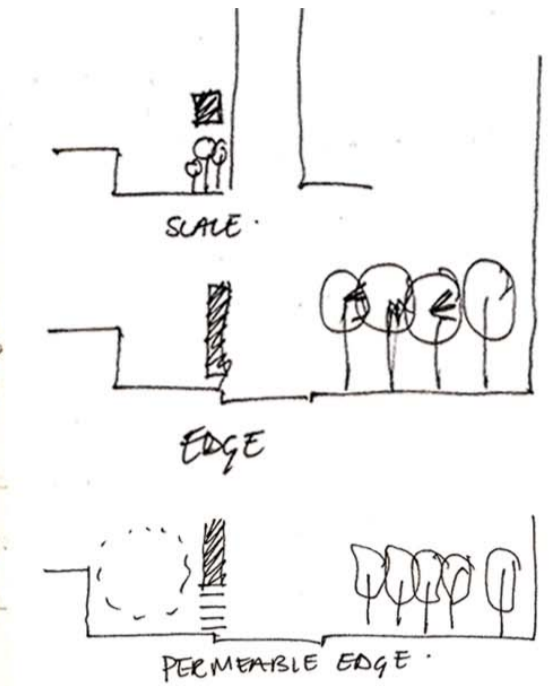
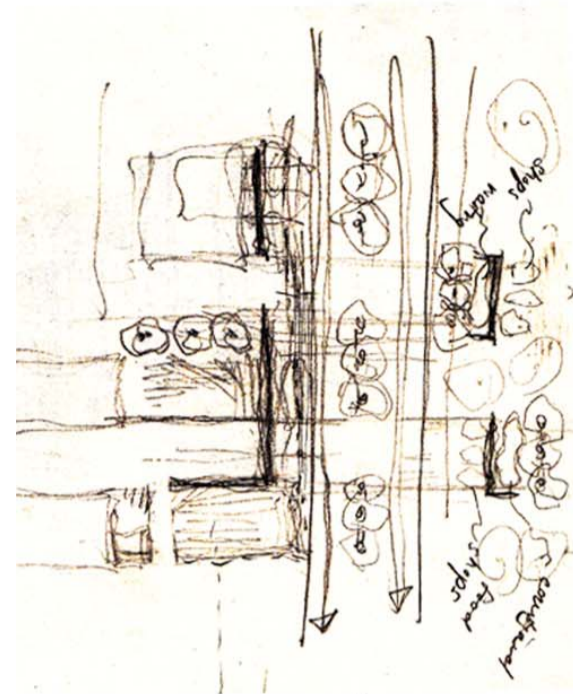
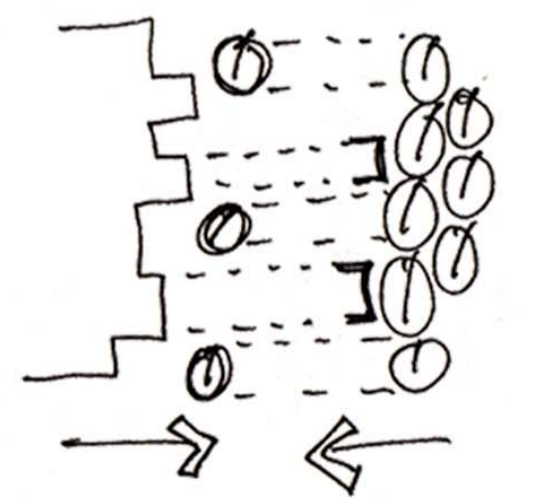
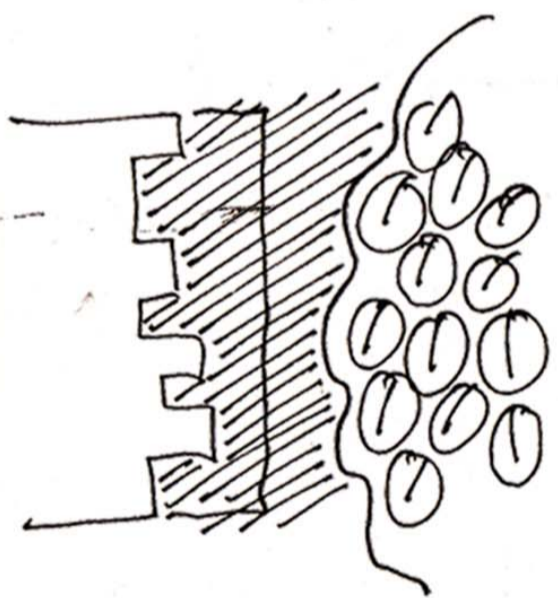
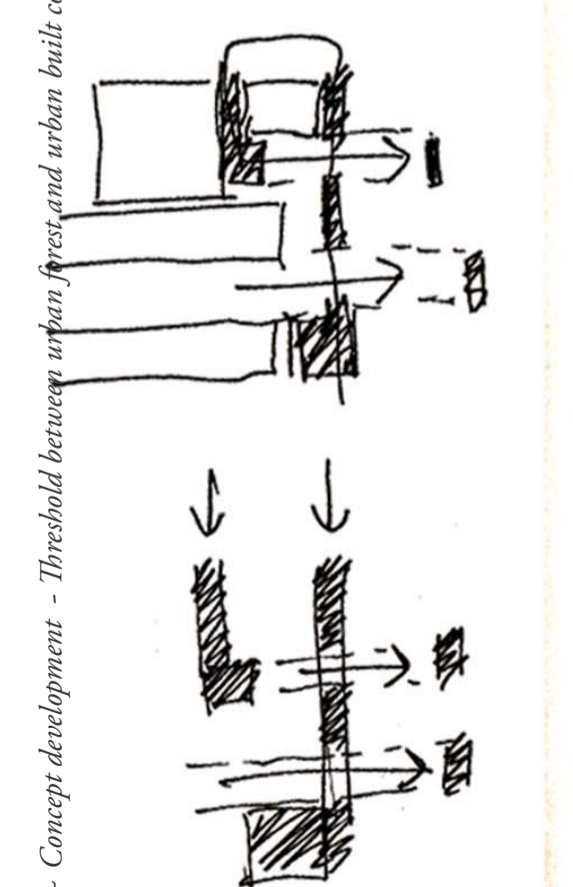
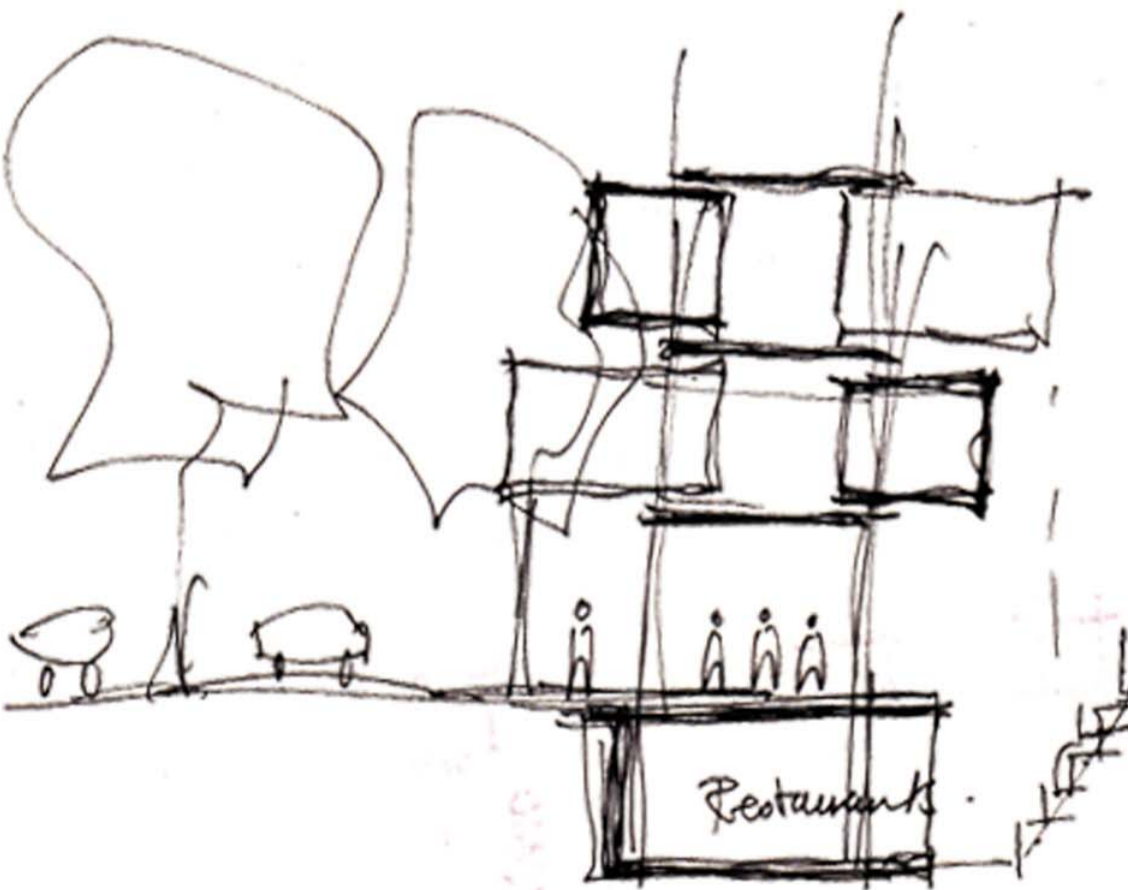
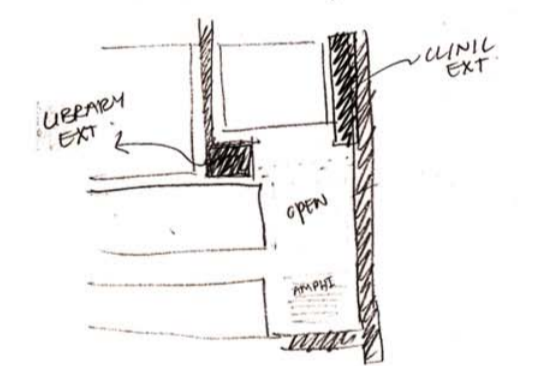
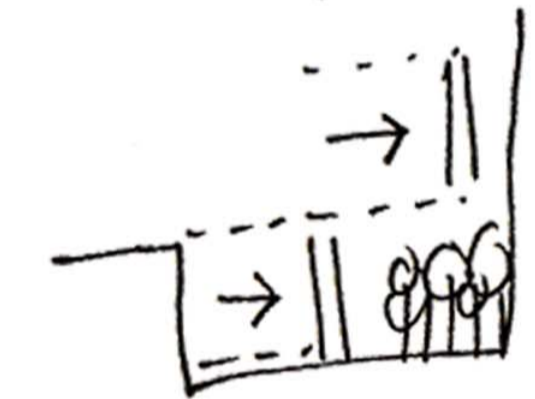
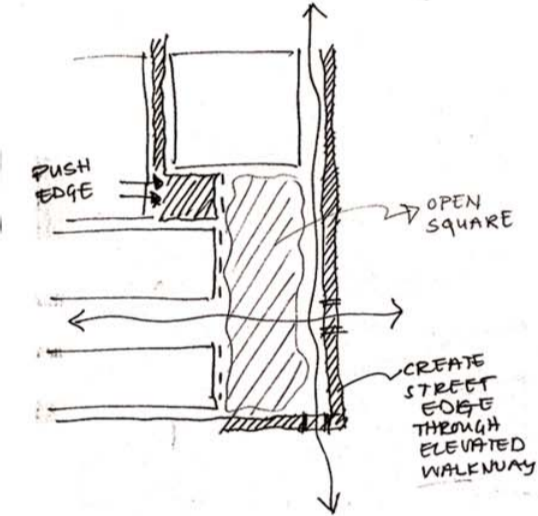
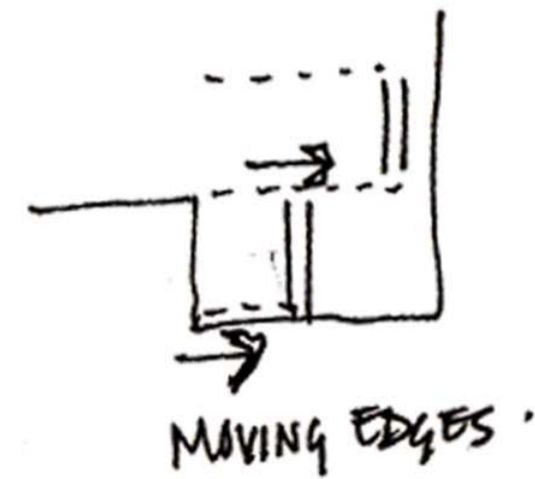
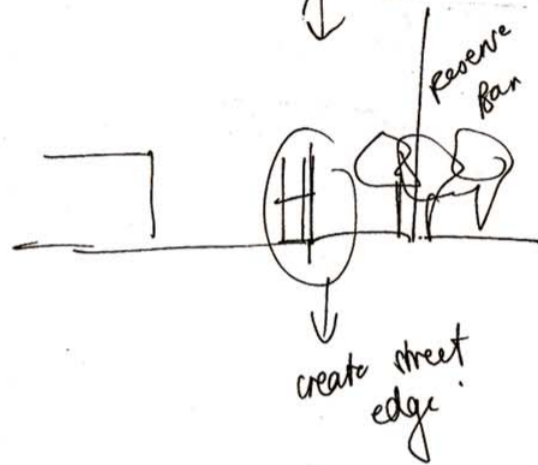
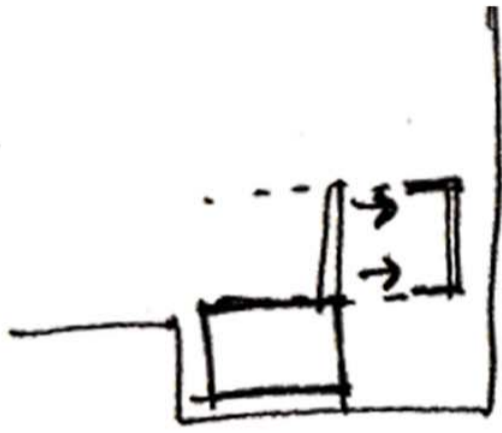
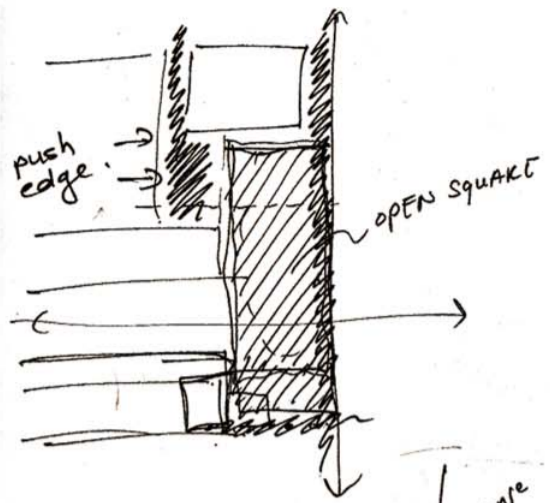
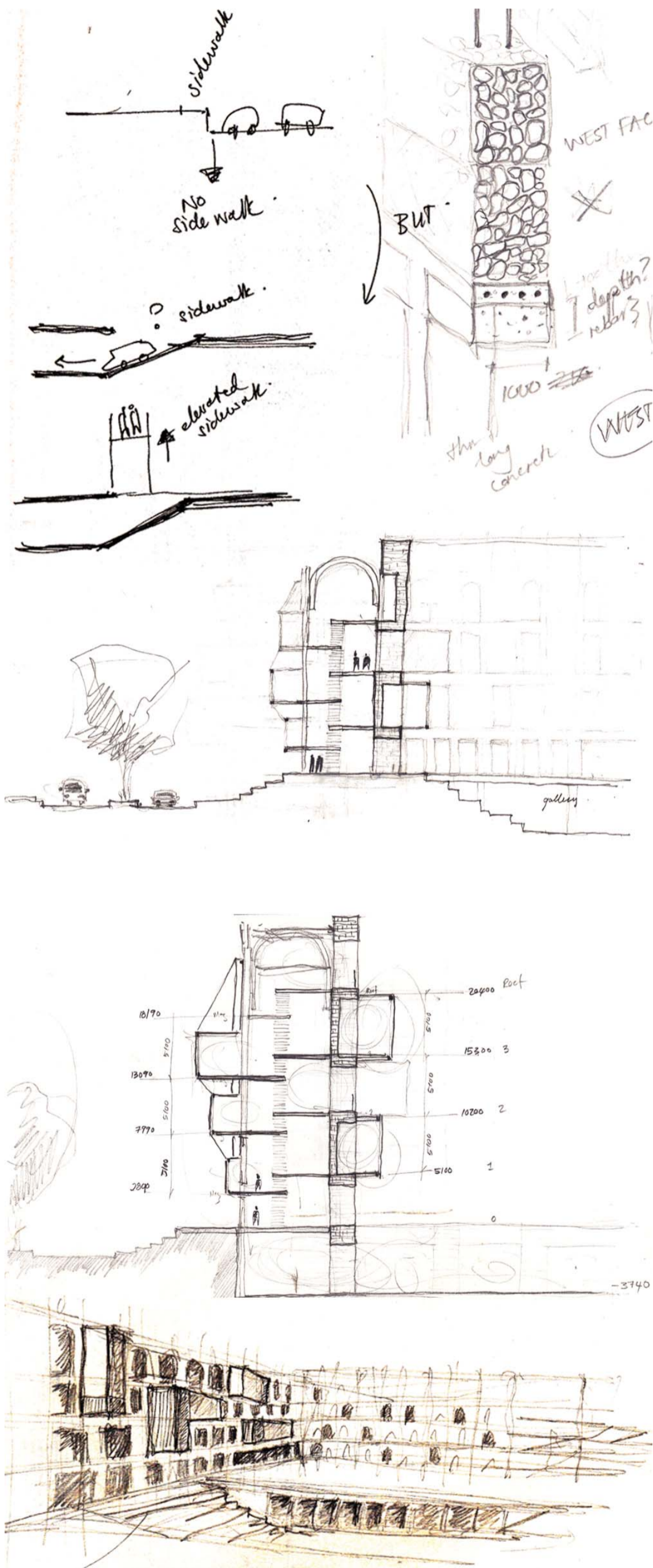

Figure 6.14 - Concept development - Threshold between urban forest and urban built condition.psd







Threshold between urban built and urban forest

Process and development

The intervention needs to downplay the design of the existing. This design will lend the new architecture the material freedom to contrast the current architecture. The structure must weave its way through and around the existing. It must connect otherwise unconnected programmes and break the boundaries between the inaccessible and unrelated buildings. It must create positive interaction between the existing buildings. At some places it should merge with the existing and at other places it should contrast it. This balance between the familiar and the new will make it accessible and visible.

The intervention as a whole will serve as a stoep into the city. Due to its location, en route to the major transport terminals, it becomes a programmatic threshold between the dweller's home and the city. And due to its location in the larger urban vision it becomes a tectonic threshold between the man-made forest around the Reserve Bank and the man-made city to the west.

The use of a columned structure is therefore very appropriate. An architectural language of columns not only mimics the stoep, a common vernacular typology of Pretoria, it also strengthens the idea of a colonnade – a reference to gathering spaces of antiquity. A colonnade creates a permeable edge that defines the public square and creates structure for informal commercial activities.

Pretoria's arcade typology is also strengthened by the intervention. Existing arcades are kept and new ones are created. Moreover, arcades will not only stop at ground level. New arcades at higher levels are created with programmes that will enhance the existing.

The appealing rhythms on site of the Gundelfinger building will inform the grid and hence the rhythms of the new structure.

Figure 6.18 - Design development on section.psd

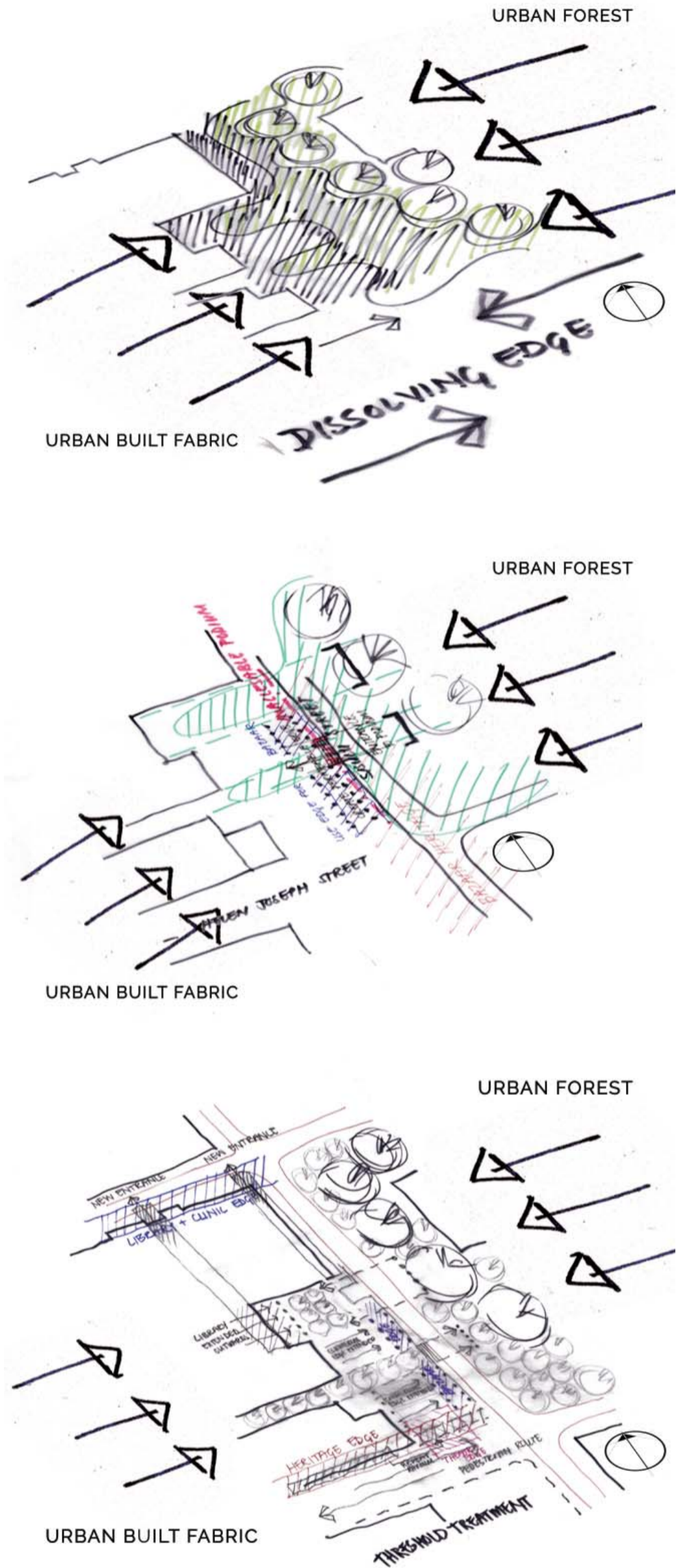

Figure 6.19 - Concept diagrams - Edge and threshold between Urban Built and Urban Forest.psd

The diagrams explain the site as becoming the threshold between the urban forest condition and the urban built condition. The middle image explains that an edge needs to be created to contain the new square and this edge becomes the point at which the two conditions meet. It also establishes that the edge must have permeability for the two opposing conditions to interact. The bottom image deals with the threshold of each of the programmes on site and how they should be addressed.

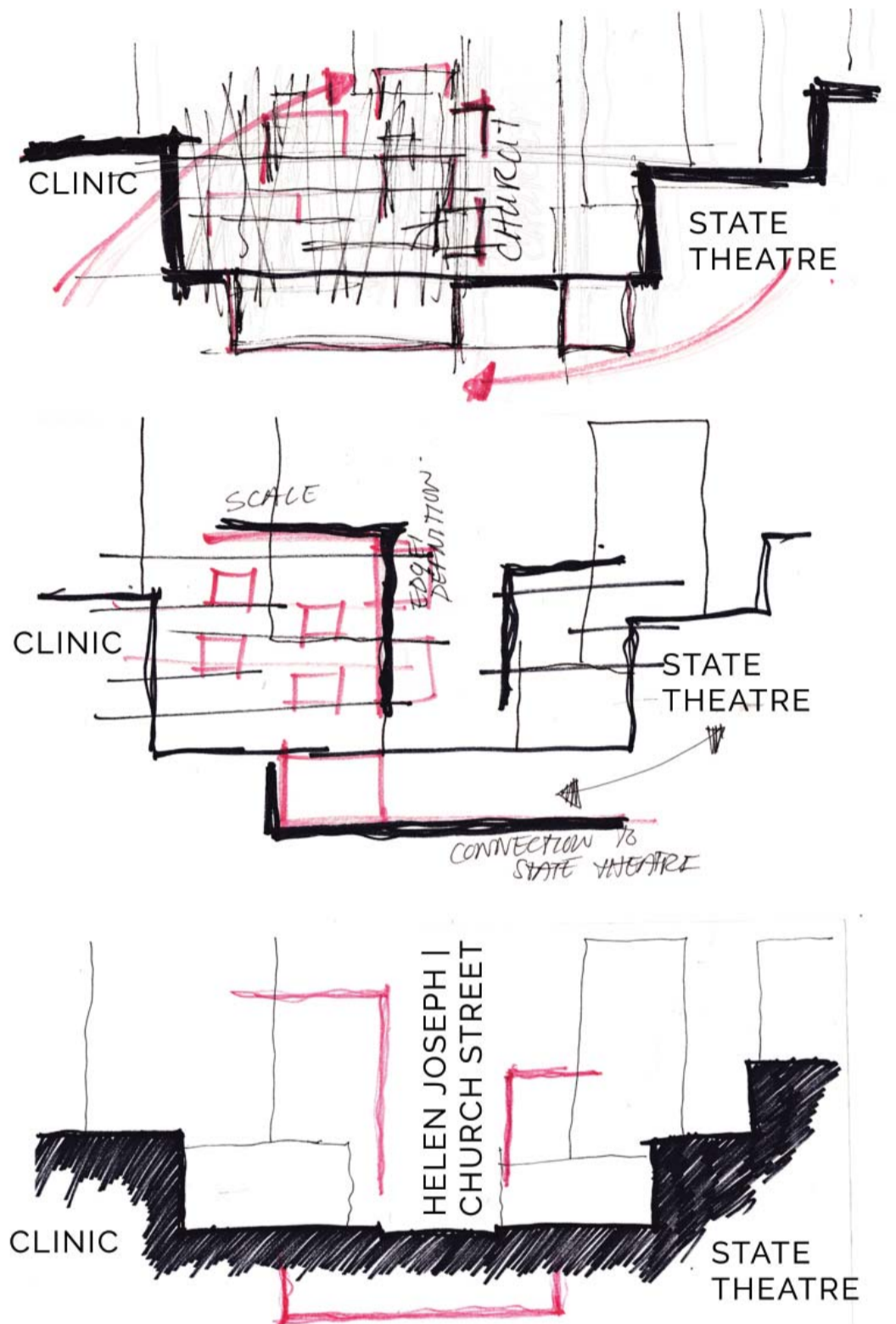

Figure 6.20 - Concept development on north-south section.psd

The diagrams explain the site as becoming the threshold between the urban forest condition and the urban built condition. The middle image explains that an edge needs to be created to contain the new square and this edge becomes the point at which the two conditions meet. It also establishes that the edge must have permeability for the two opposing conditions to interact. The bottom image deals with the threshold of each of the programmes on site and how they should be addressed.

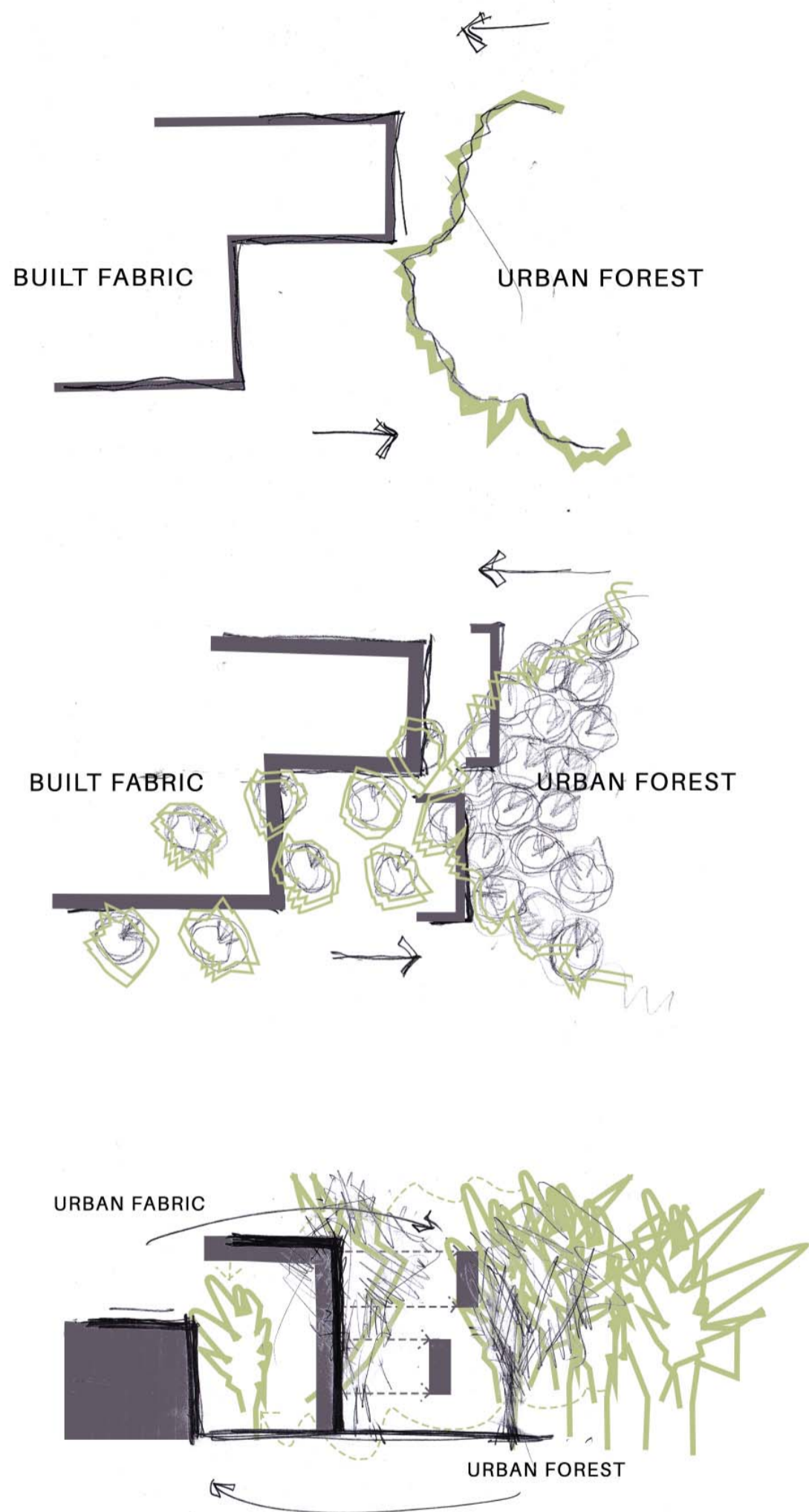

Figure 6.21 - Concept diagram - Urban Built versus Urban Forest.psd

These diagrams indicate the intention on the east-west section. The site becomes the threshold between the urban forest and the urban built fabric. As the forest dissolves into the city the city condition pushes itself into the urban forest.

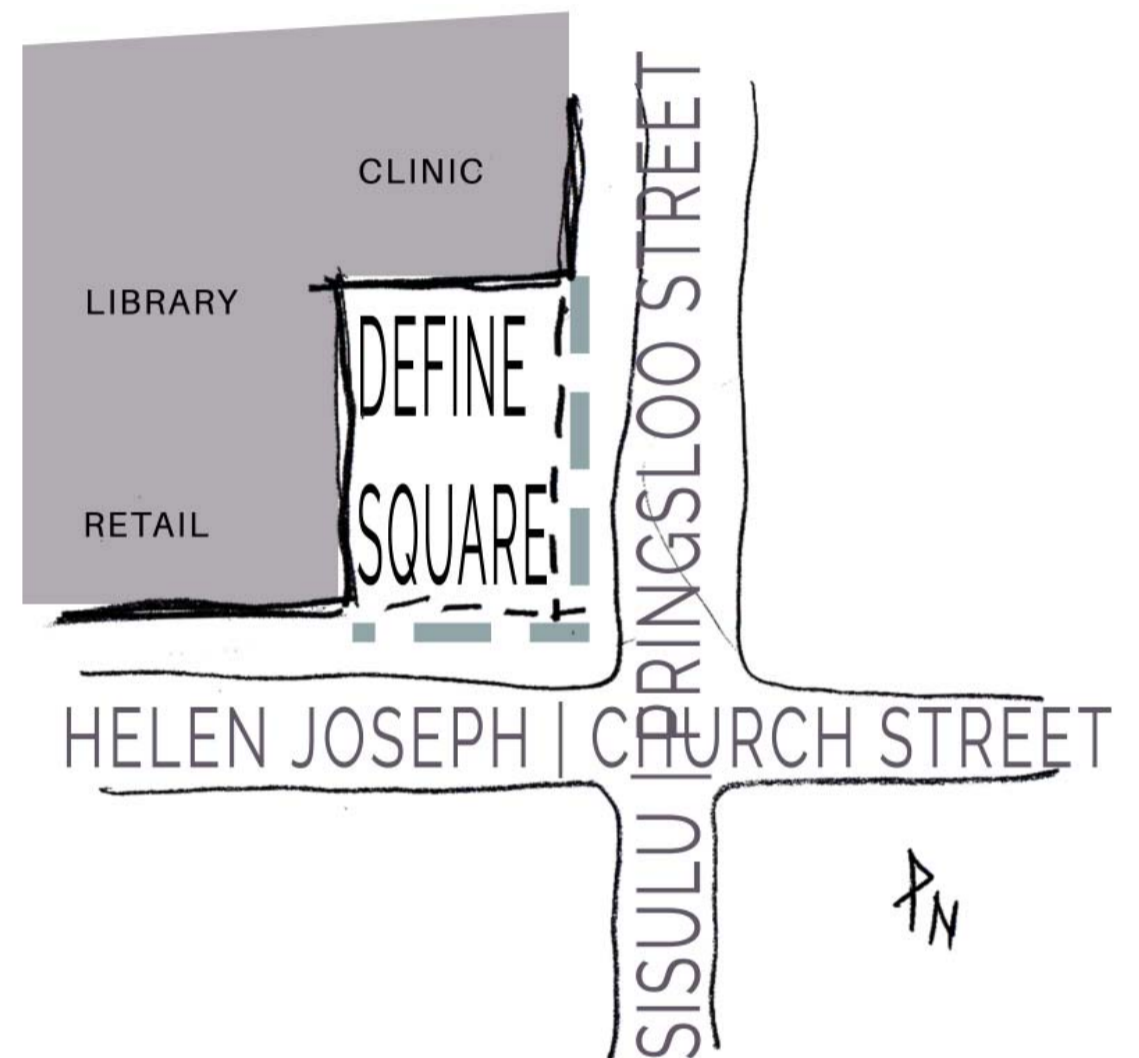

Figure 6.22 - Concept diagram - Define public square.psd

This diagram indicates the intention of creating a defined space that can become a public square. The site is currently a fenced off, forgotten construction site with no sense of place. It is therefore important to create an edge around the site to contain the space. This edge will serve as a colonnade from this stoep into the city.

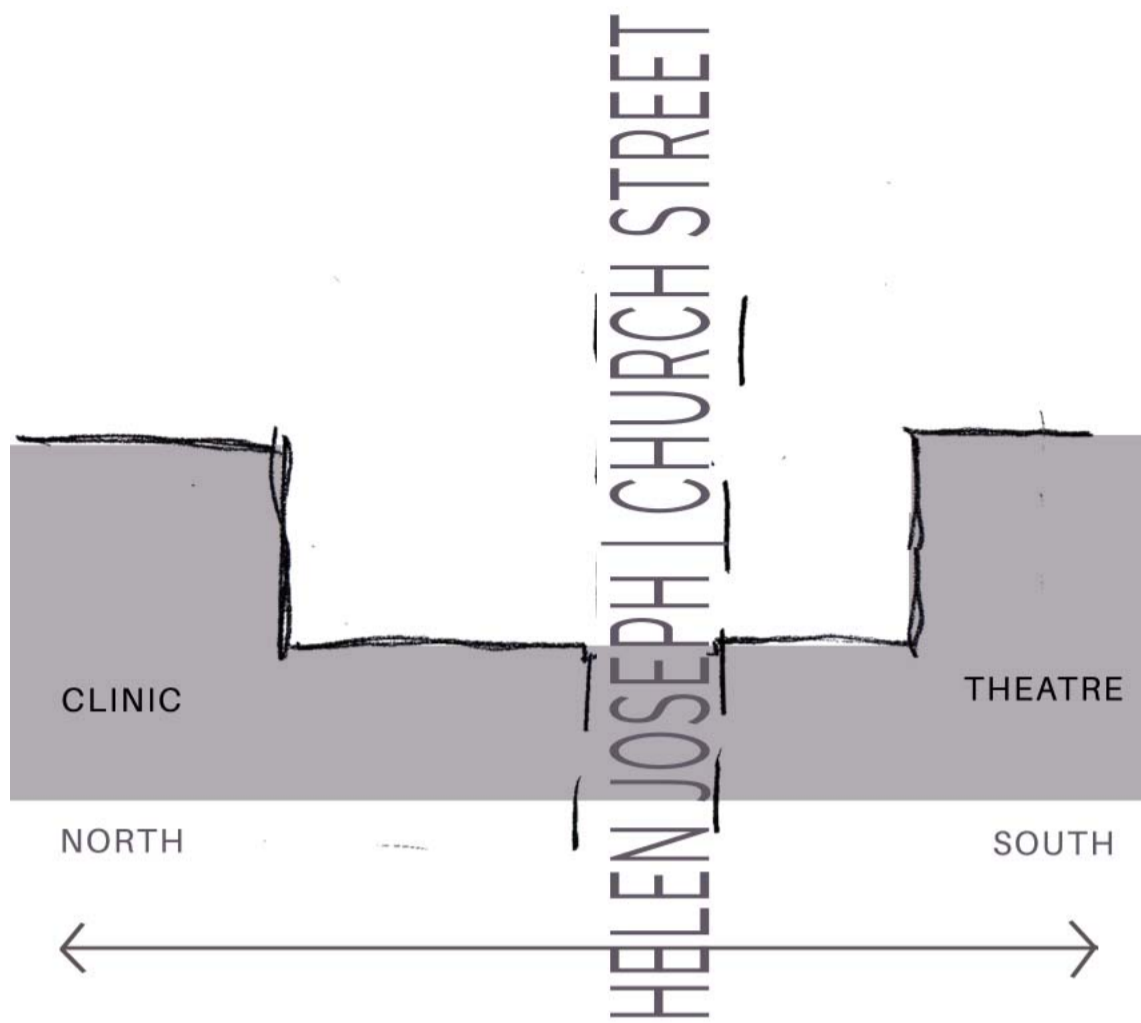

Figure 6.23 - Concept diagram - Helen Joseph (Church) Street axis.psd

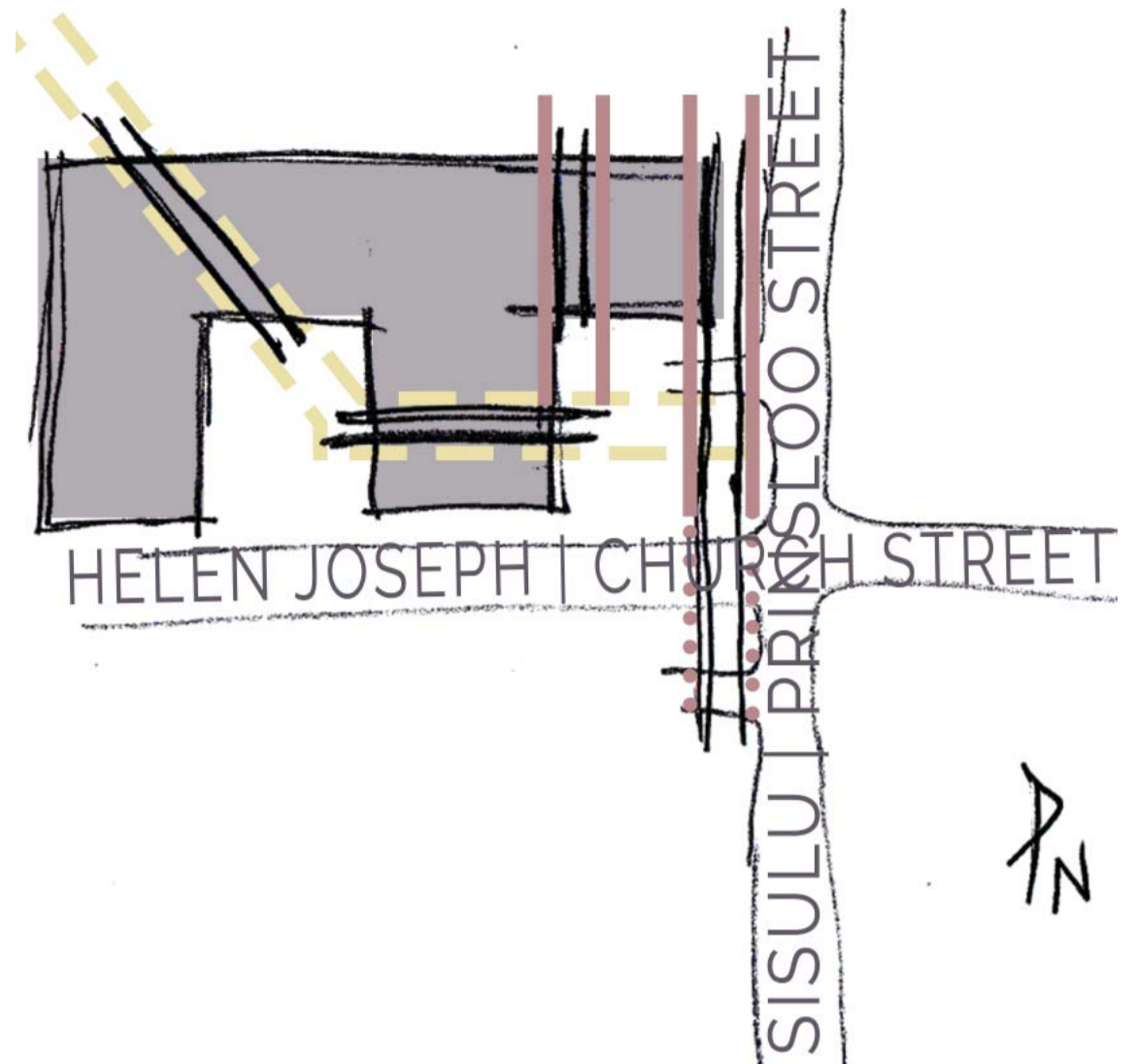

Figure 6.25 - Concept diagram - Define existing and new arcades.psd

This explains that the existing arcade is kept and extended and a new arcade between the library and the clinic is added. The edge of the site also serves as a colonnaded entrance to the square, but also as an arcade with programmes spilling off from it.

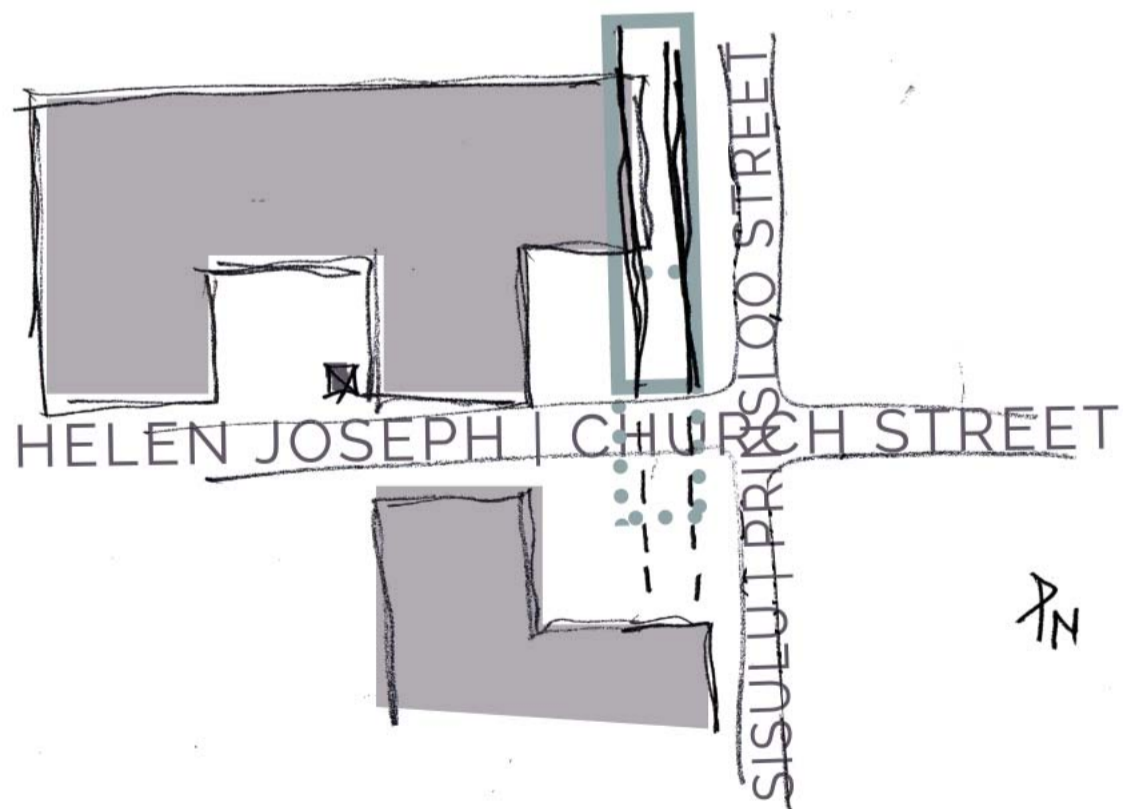

Figure 6.24 - Concept diagram - Underground connection to theatre.psd

Helen Joseph (Church) Street is a very prominent street in the history of South Africa as discussed in previous chapters. It is therefore important to keep the street visually uncluttered. As mentioned earlier, any connection to the State Theatre should be done underground.

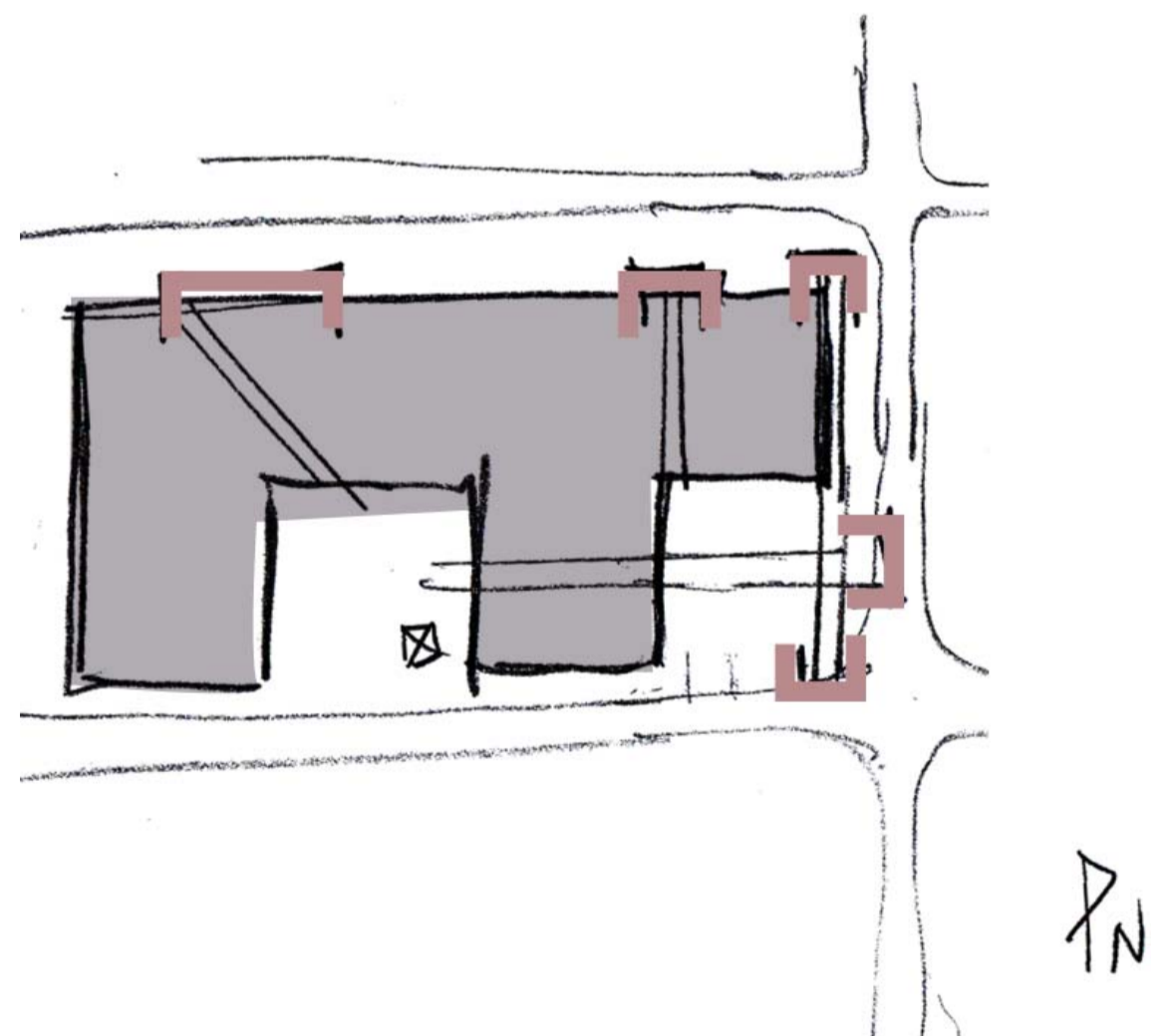

Figure 6.26 - Concept diagram - Define new entrances.psd

New entrances to the library and clinic are added to the north and the existing and new arcade also has definite thresholds.

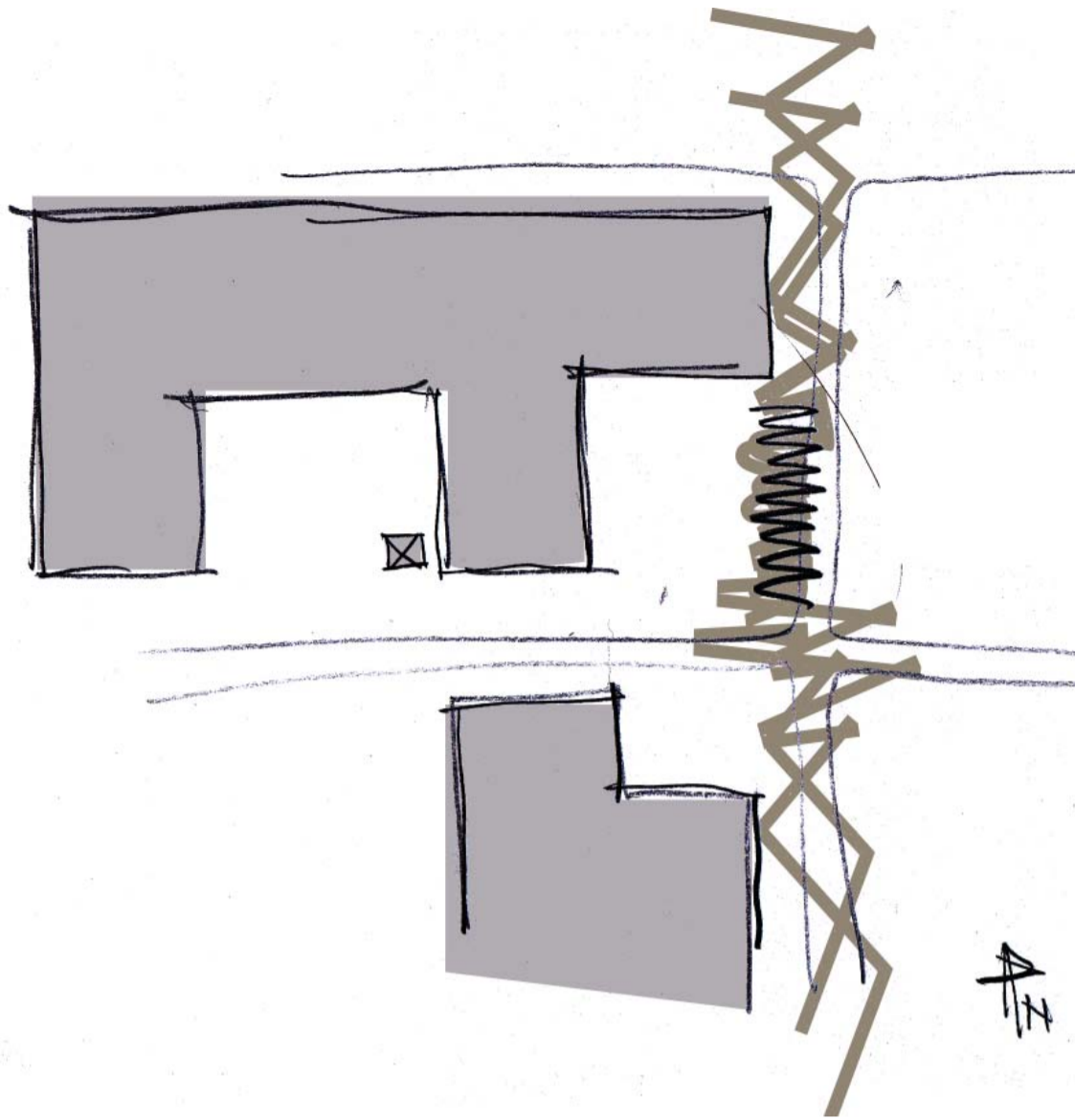

Figure 6.28 - Concept diagram - Significance towards historic Asiatic Bazaar.psd

The importance of reclaiming the energy previously generated by the Asiatic Bazaar is illustrated.

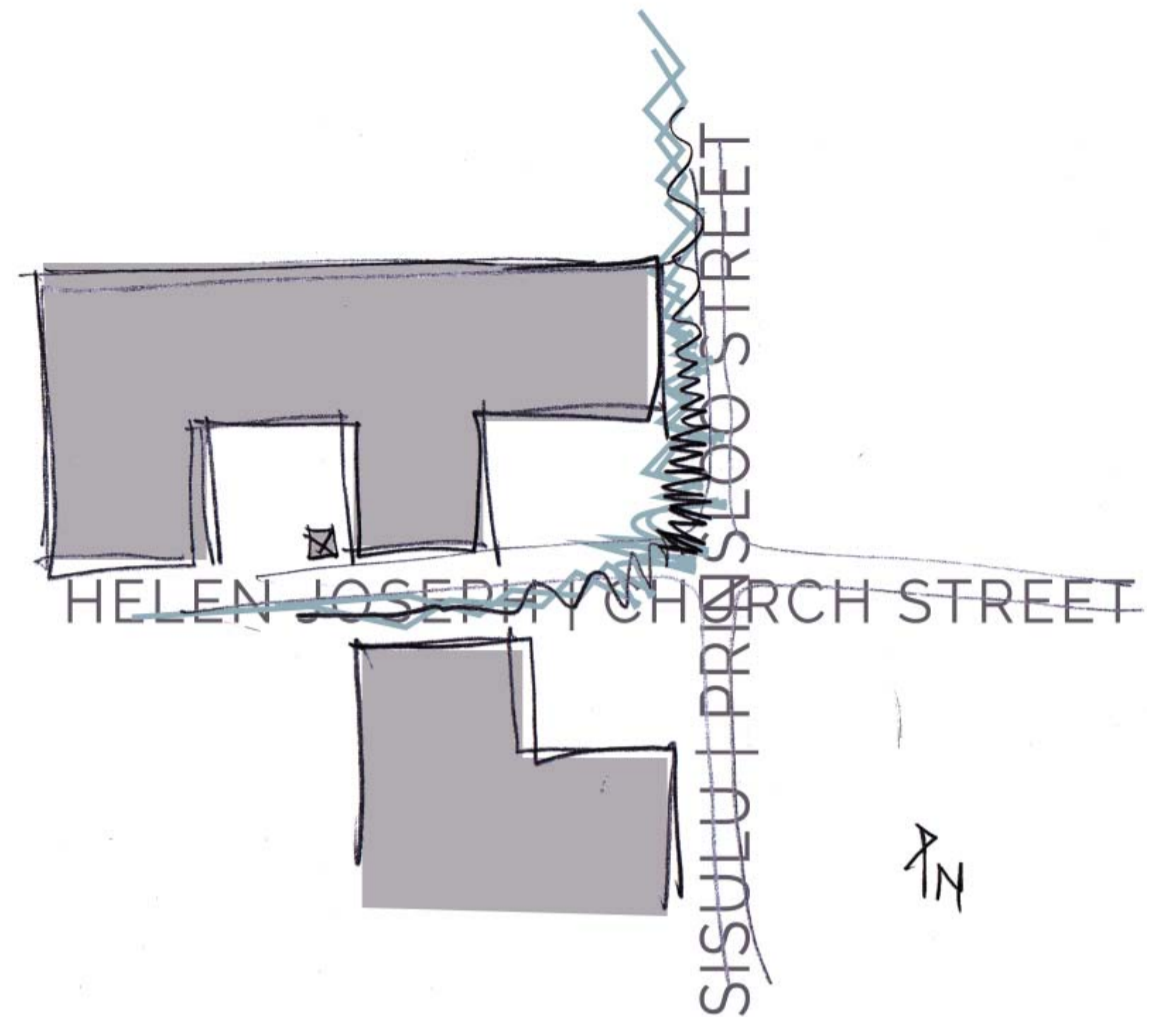

Figure 6.29 - Concept diagram - Significance towards historic water furrows.psd

This illustrates the route of the water furrows and where it will have greatest the influence on the site.

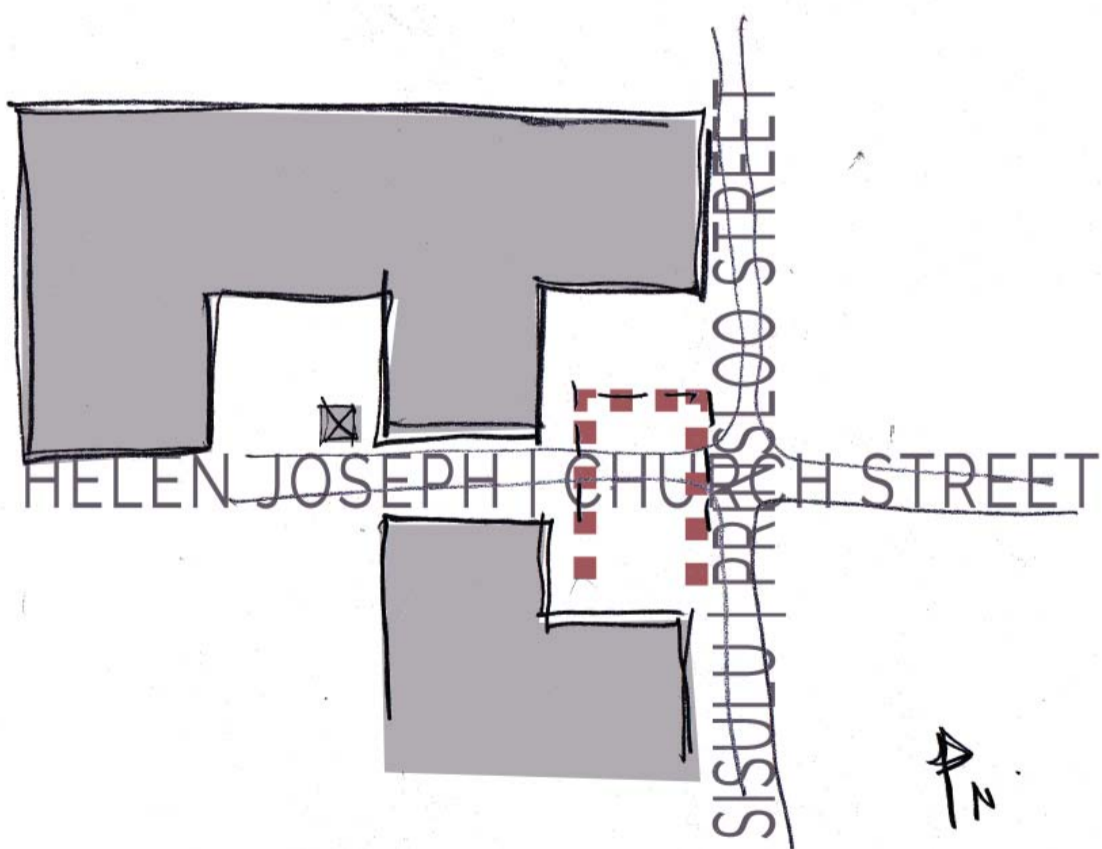

Figure 6.27 - Concept diagram - Site connection with theatre.psd

The most appropriate site for the open air amphitheatre is indicated. It connects with the State Theatre via the basement.

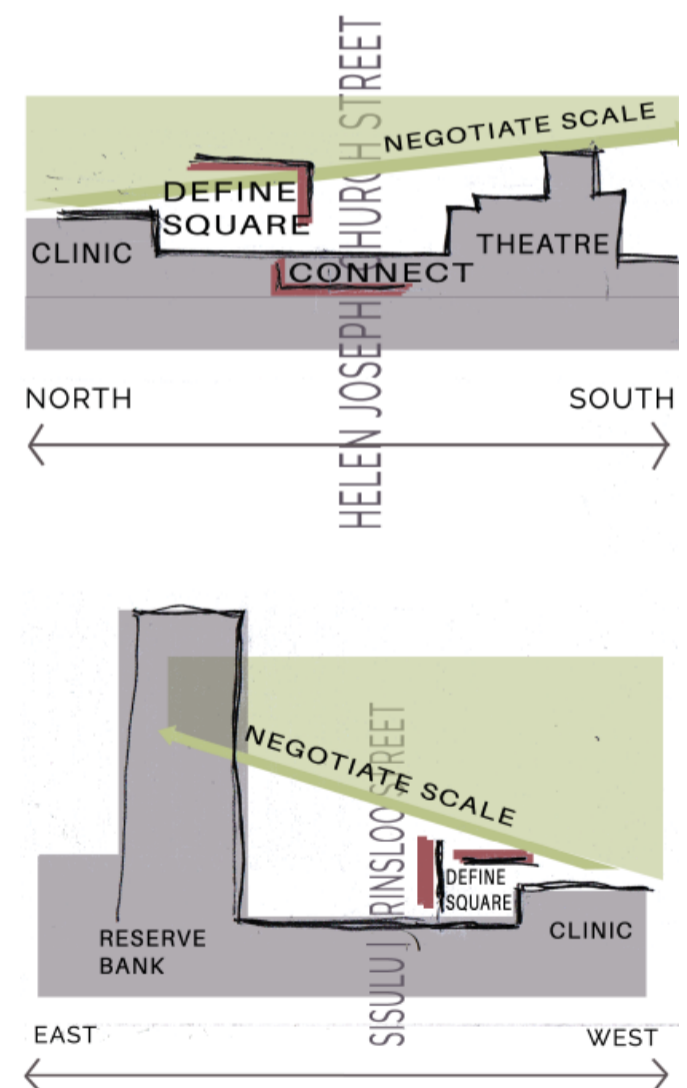

Figure 6.30 - Concept diagram - Scale and space definition.psd

As discussed in the previous chapter the new intervention will not try to bridge the scale with the Reserve Bank, but instead attempt to tie in with the scales of this historic part of Pretoria. It will therefore aim to match the scale of the State Theatre.

These diagrams, and consequent model explorations, explain the main drivers of the design. Of the site conditions more were however integrated in the design. These will be discussed in more specific terms in the section on design responses.

DESIGN RESPONSES

The site has a rich and complex narrative and became the main driver for the architecture. The design responds to the existing programmes by allowing the programmes to spill out of the existing buildings and into the street. It also responds to the buildings by attaching to them and extending their boundaries, as well as creating new alternative entrances. The materiality of the site is another driver and allows for the recognition of the familiar and the visibility of the new. The pedestrian circulation in the CBD is also responded to. It is programmatically strengthened and aesthetically articulated. The design finally responded to the environmental conditions by focussing on the smart treatment of western and eastern façades, as well as water harvesting methods. These responses will be discussed henceforth.

Programmatic Responses

The programmes responded to include the library, the clinic, the theatre and retail.

Library

As part of the greater urban vision the library falls under the civic precinct with the new Tshwane House and the existing clinic. The eastern façade of the library faces the site of intervention. On the ground floor of the library a café and a music library can be designed to spill out onto a newly designed library courtyard. It will also serve as an alternative entrance into the library.

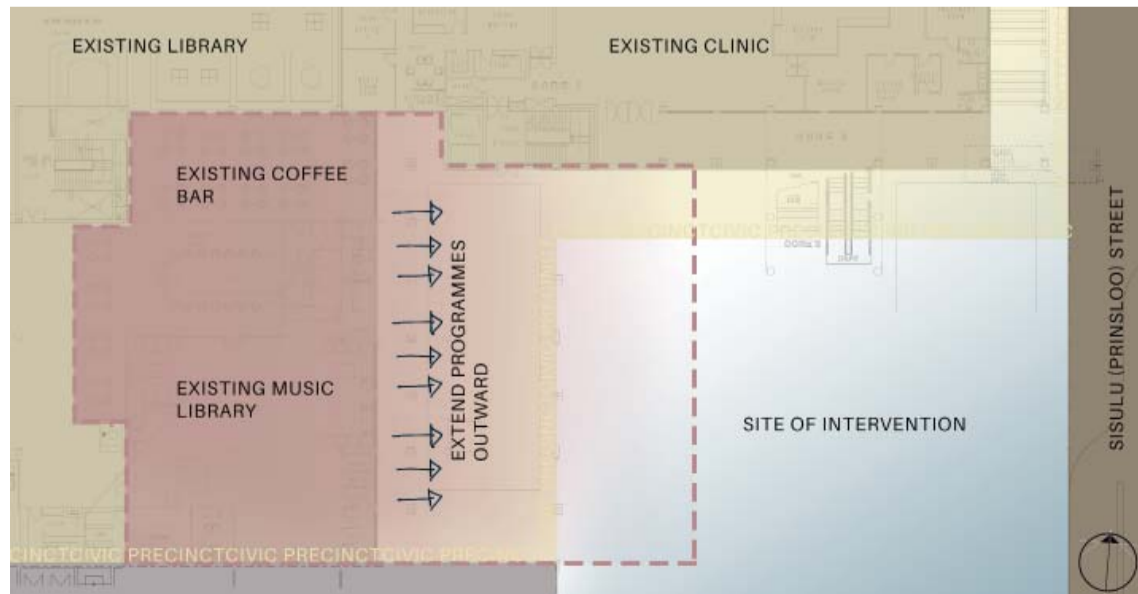

Figure 6.31 - Library intervention.psd



Figure 6.32 - Library on site.psd

A café and a music library designed to spill out onto a shaded courtyard.

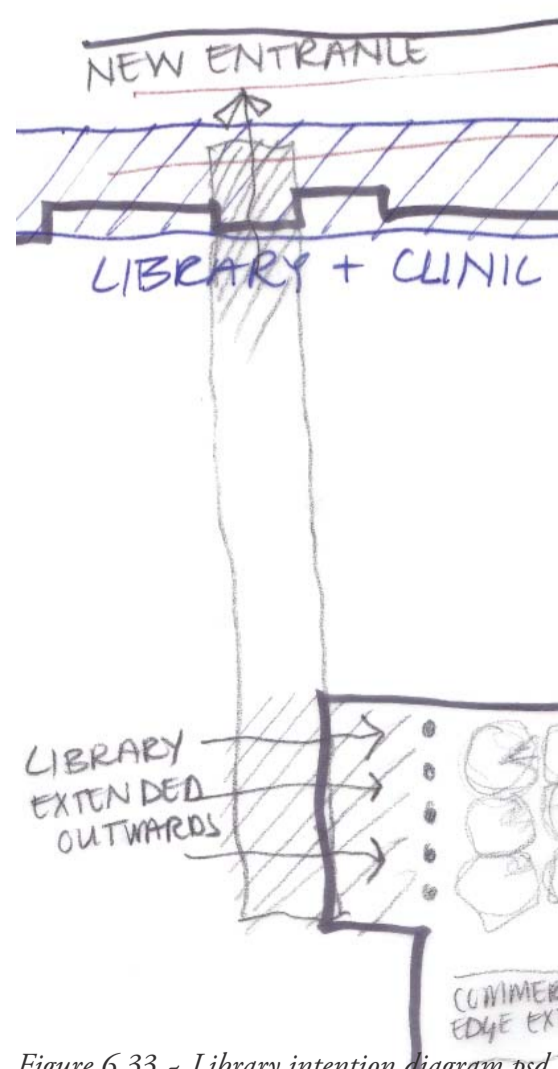

Figure 6.33 - Library intention diagram.psd

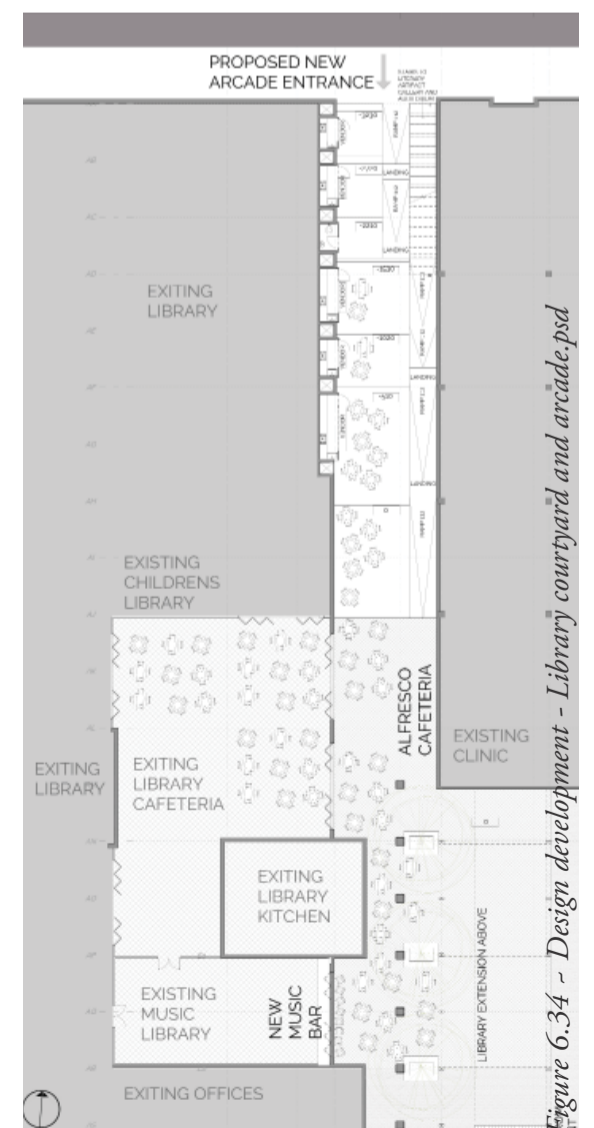

Figure 6.34 - Design development - Library courtyard and arcade.psd



Figure 6.35 - Clinic on site.psd

Clinic

The existing clinic's entrance on the ground floor is not visible and unobtrusive. The suggestion is to create a new entrance to the north where it meets the corner of Madiba (Vermeulen) and Sisulu (Prinsloo) Streets. It is also a very busy pedestrian route and will be more visible and accessible. The existing corridor next to the clinic can also be re-appropriated to include auxiliary programmes for the clinic.

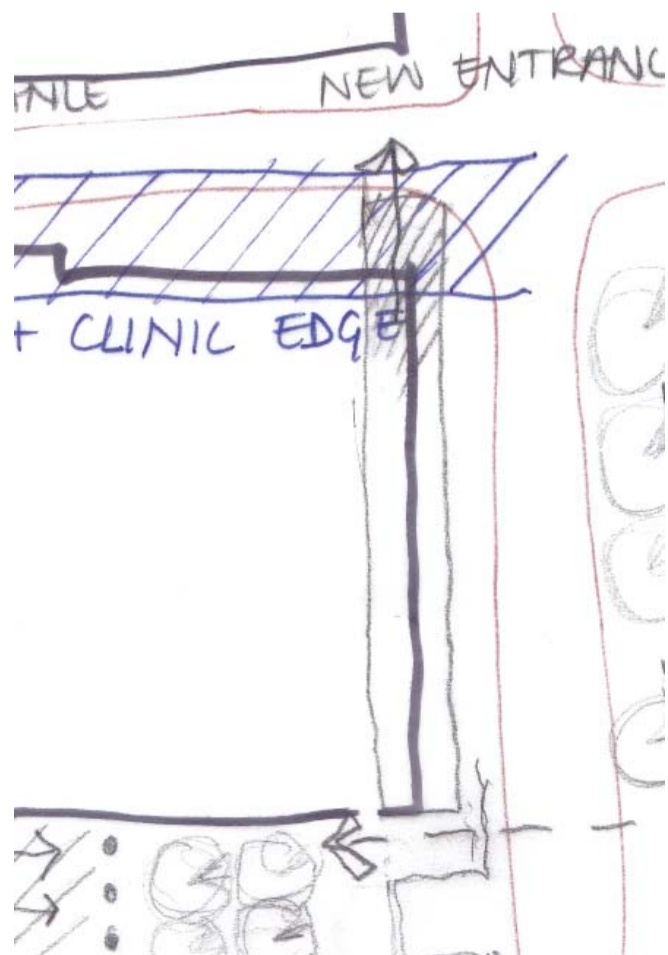

Figure 6.36 - Clinic intention diagram.psd

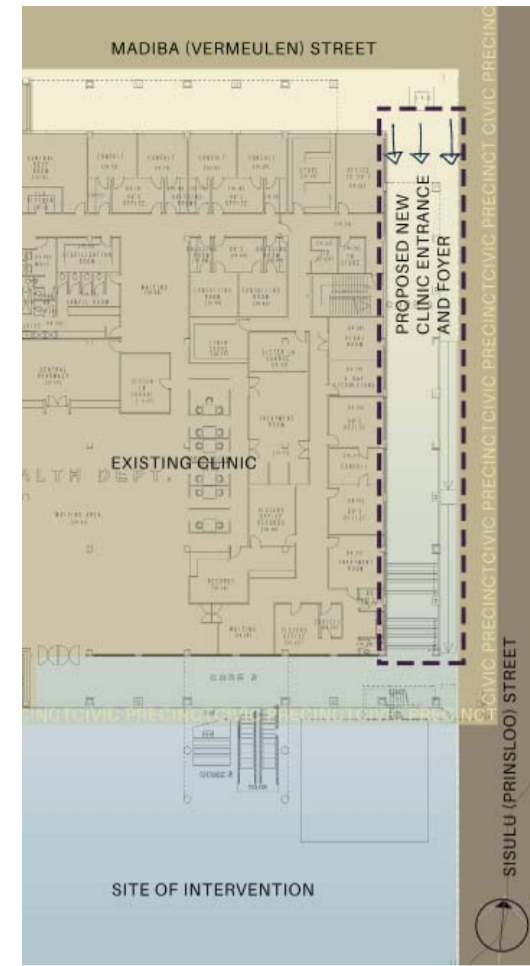

Figure 6.37 - Clinic intervention.psd

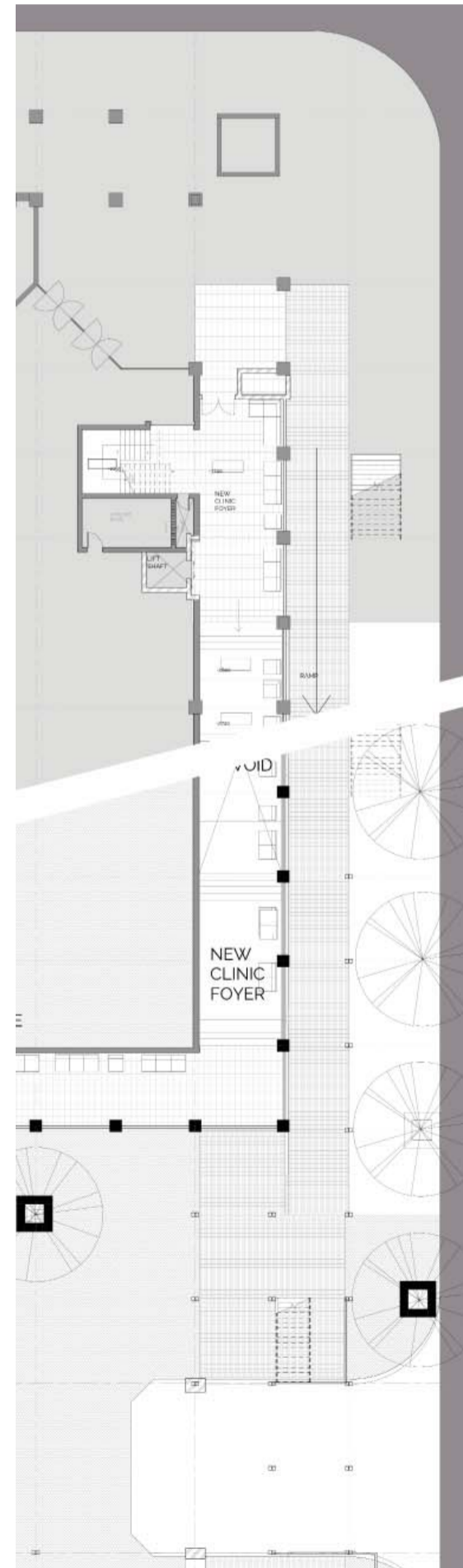

Figure 6.38 - Design development - New entrance and foyer to clinic.psd

Theatre

As part of a greater cultural precinct the theatre's extension beyond its physical walls are paramount. In the urban vision, the extension of the State Theatre was suggested by zoning the area in front of it as the foyer to the State Theatre, and for future interventions to use this new space to connect the State Theatre to the street. The basements of State Theatre and the Sammy Marks Centre are currently not connected, but the intention is to connect it and to augment the programme of the State Theatre with an outdoor amphitheatre. This amphitheatre will then be accessible via the basement parking of both the State Theatre and the Sammy Marks Centre.



Figure 6.39 - Theatre on site.psd

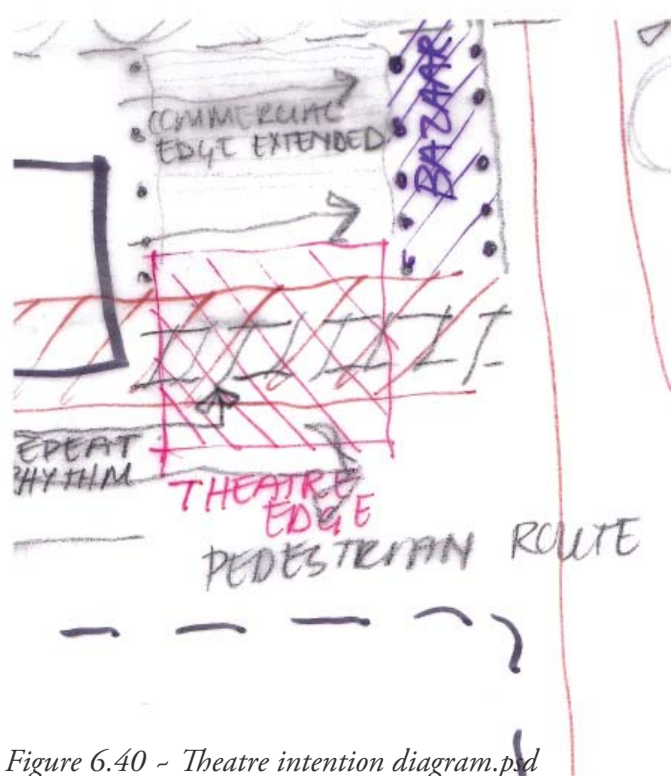

Figure 6.40 - Theatre intention diagram.psd

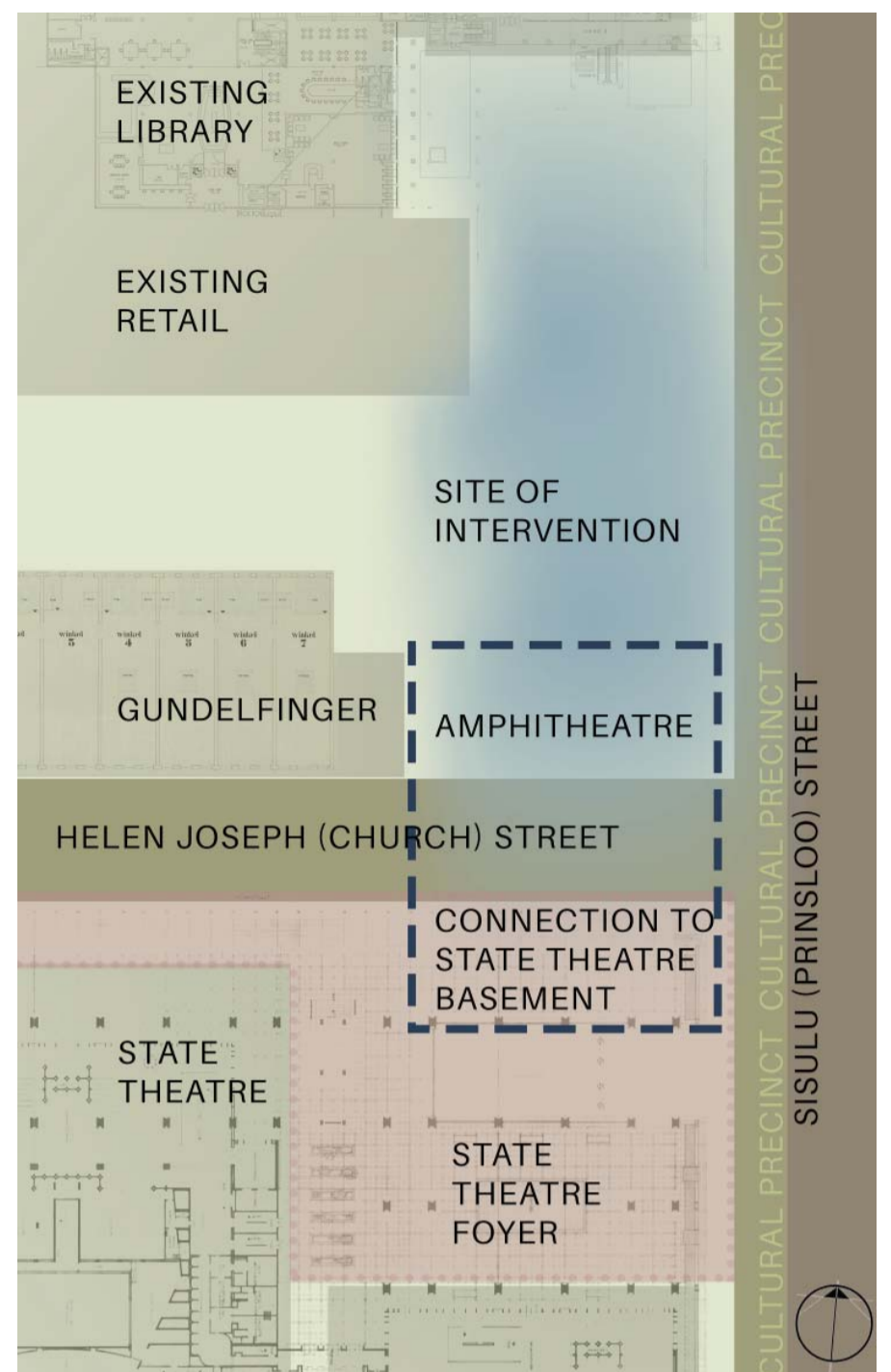

Figure 6.41 - Theatre intervention.psd

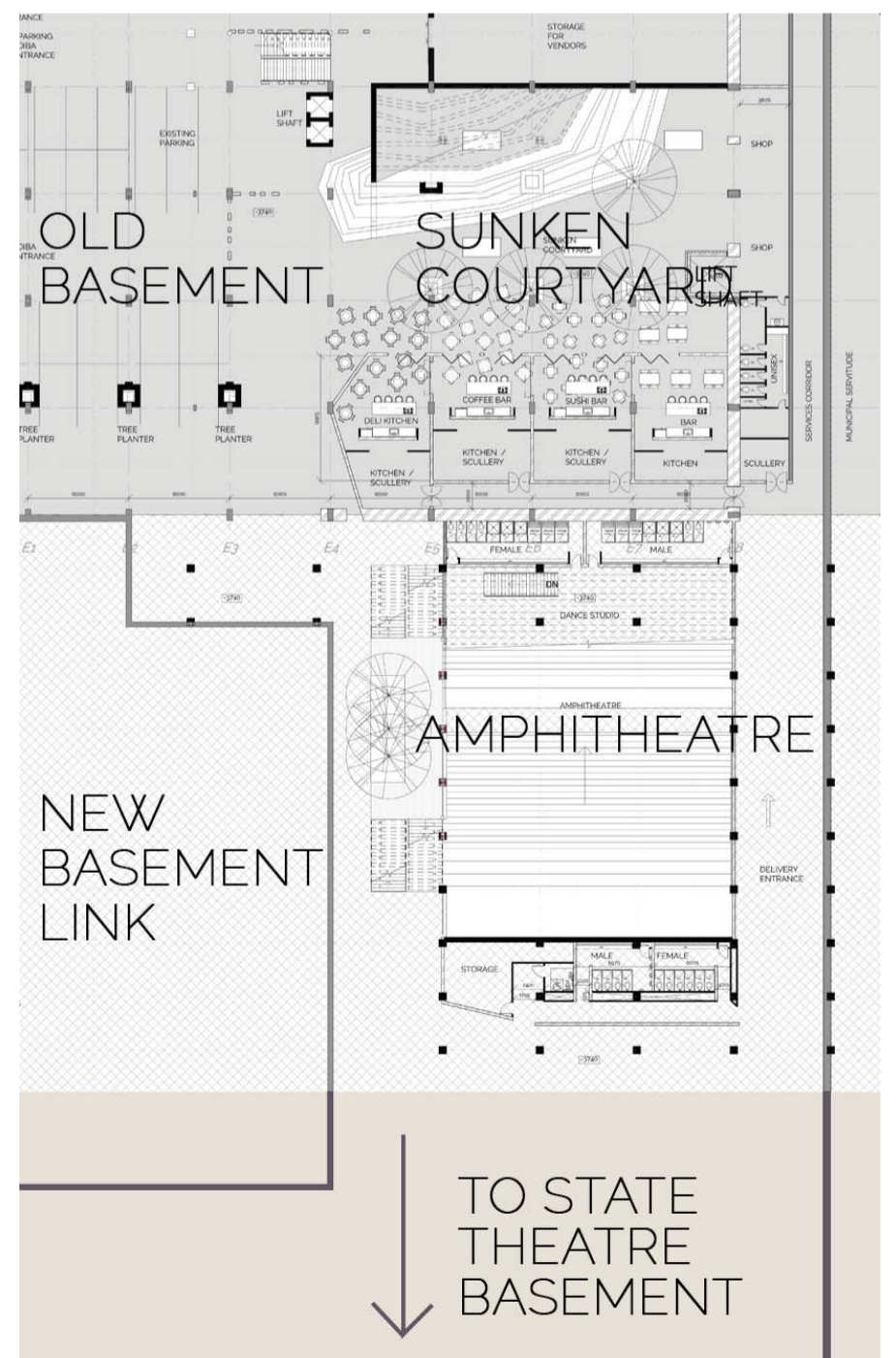

Figure 6.42 - Design development - Amphitheatre.psd

Retail

As discussed in the historical conditions of the site, Sisulu (Prinsloo) Street used to be a vibrant shopping street. Unfortunately the historic condition was lost. However the resilience of the informal vendor makes it possible to restore this condition. The informal vendors claim the street edges wherever there is the possibility of pedestrian traffic. This approach can be capitalised on. The site is situated on route from Bloed Street Taxi Terminal to Pretoria Station. It is therefore ideal to form a supporting structure for vendors.



Figure 6.43 - Retail on site.psd

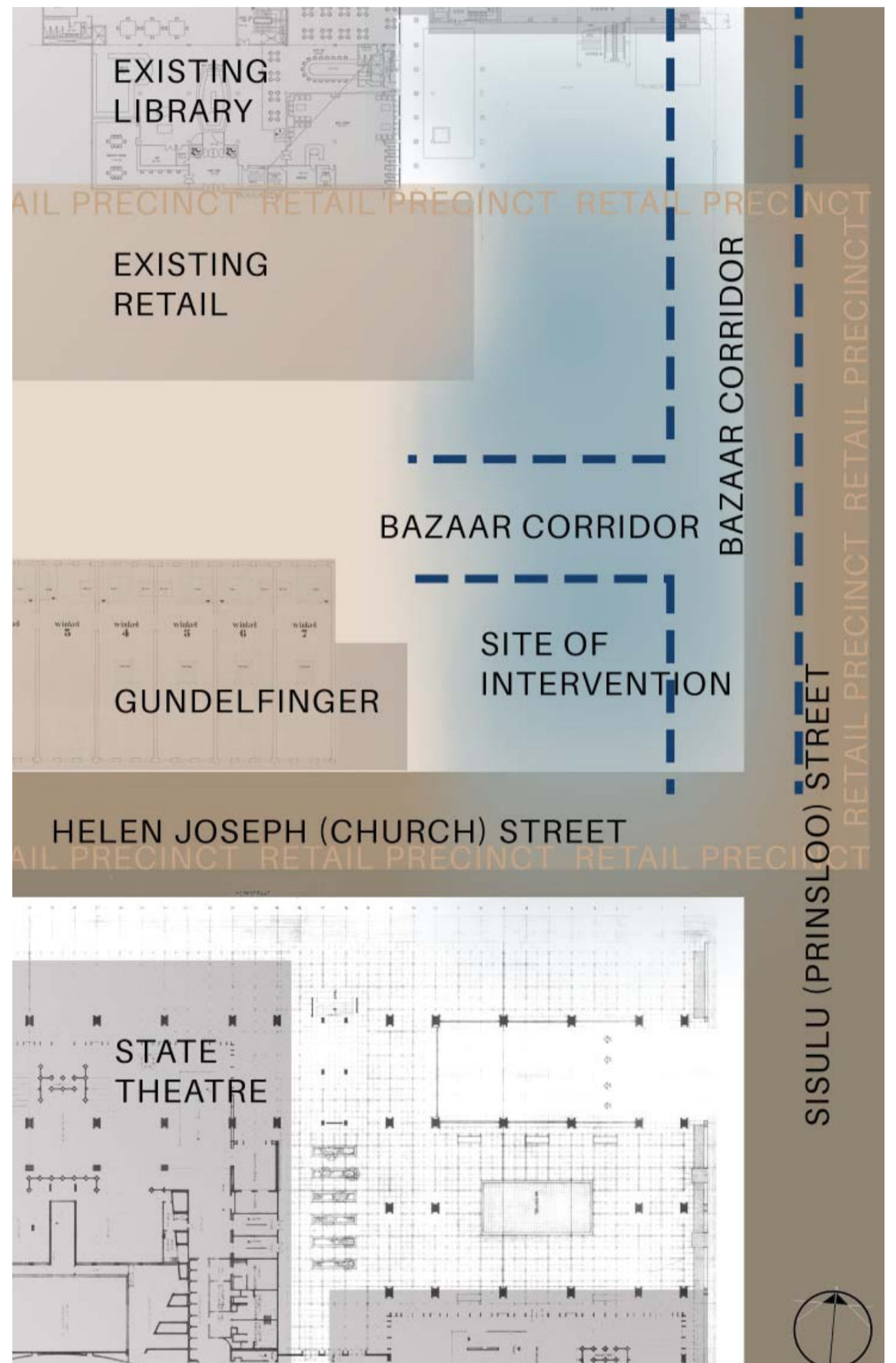

Figure 6.44 - Retail intervention.psd

Building response

The buildings specifically responded to were the State Theatre, Gundelfinger, the Sammy Marks Centre, the Reserve Bank and the Urban Forest.

State Theatre

The State Theatre building was responded to in scale and mass. The new intervention bridges the scale between the ground floor square and the heights of the surrounding buildings by creating a structure of a similar height to the State Theatre. The massing of the State Theatre forms part of the Urban Built condition which conceptually roots the design in this specific context.

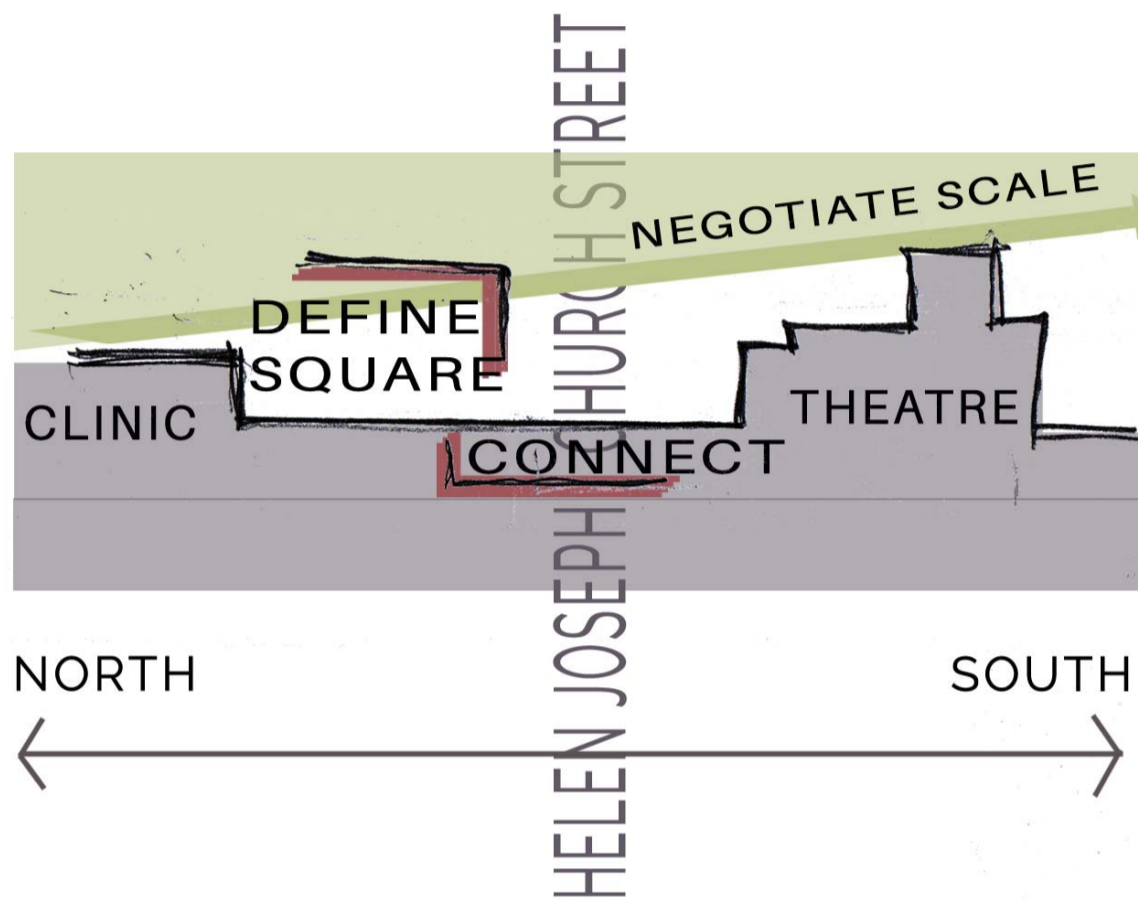

Figure 6.45 - Response to State Theatre building.psd

Gundelfinger

The Gundelfinger building is the oldest and most dignified on site. It gives the site its gravity. Conceptually it became the cornerstone or datum point for the design. The rhythm in the facade of the Gundelfinger building was analysed, repeated and extended to create an order on the site. It ordered the grid on site and it informed the proportions of the design.

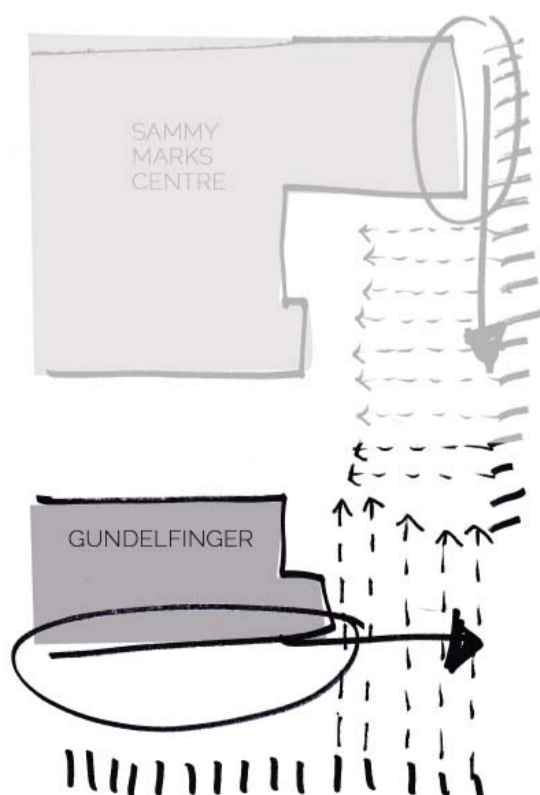

Figure 6.46 - Meeting of two rhythms - South facade repetition.psd

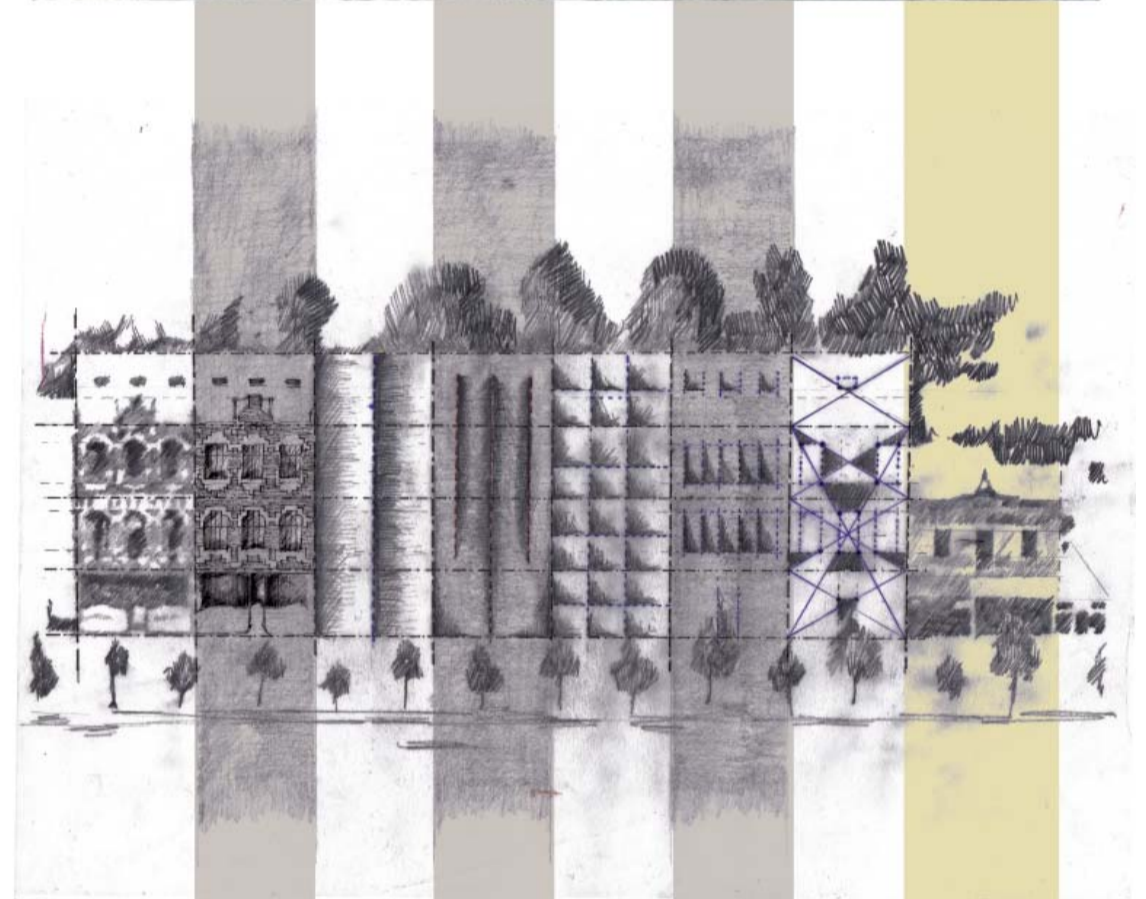

Figure 6.47 - Graphic analysis of Gundelfinger facade.psd

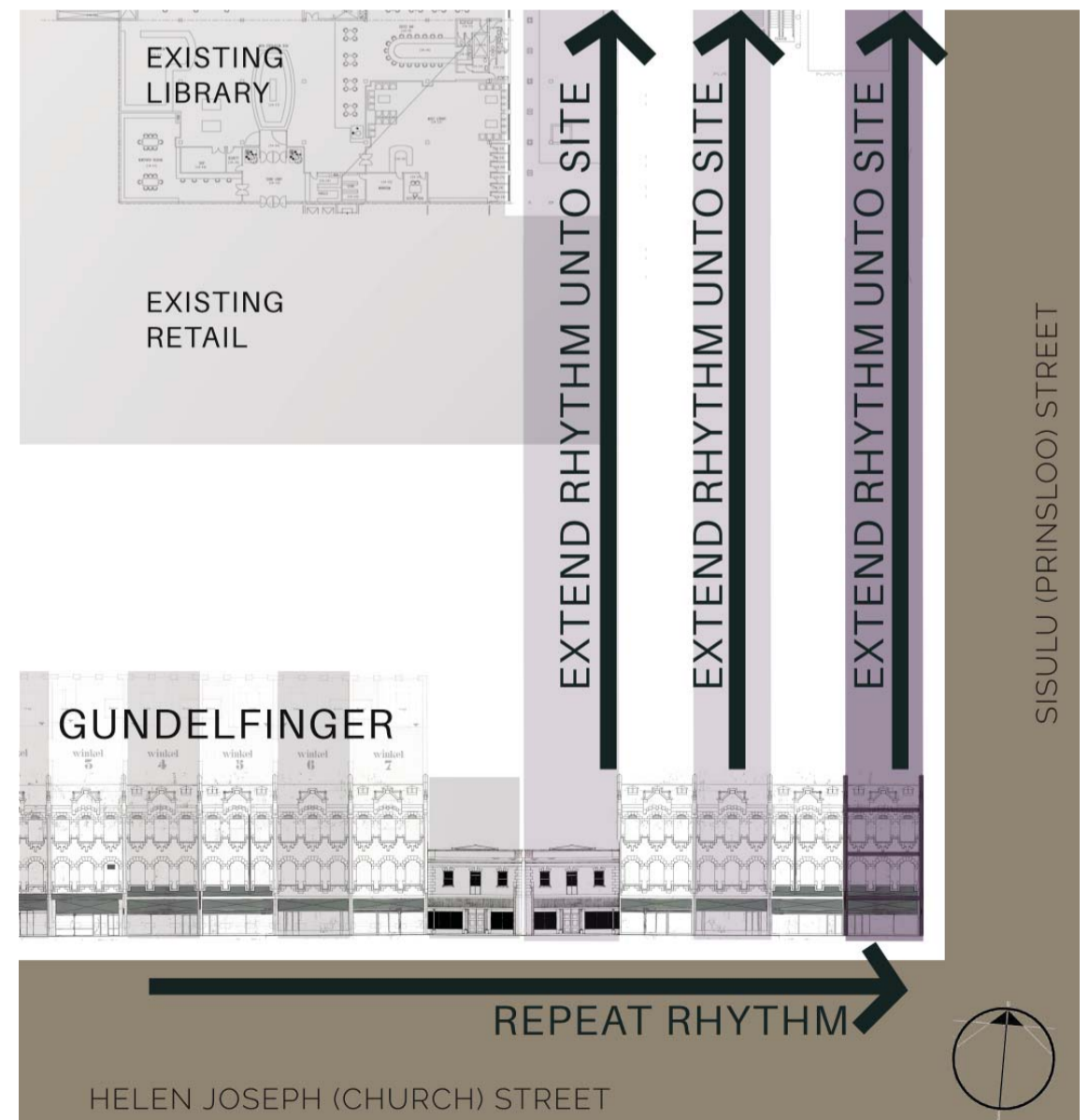

Figure 6.48 - Apply Gundelfinger facade rhythm onto site.psd

Sammy Marks

The Gundelfinger building roots the site to its contexts by determining the grid and proportions of the design. The same happens with the Sammy Marks building. The new intervention connects to and augments the clinic programme. The new structure connecting to it adheres to its rhythm and grid. This rhythm is repeated and extended.

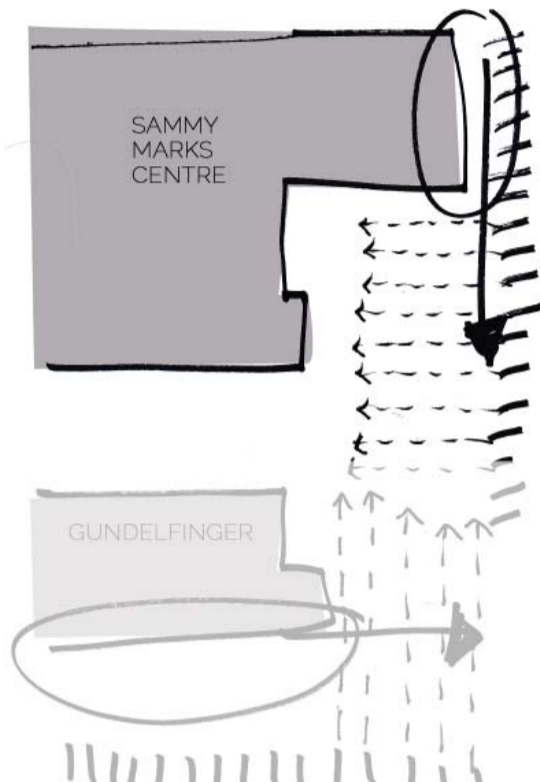

Figure 6.49 - Meeting of two rhythms - East facade repetition.psd

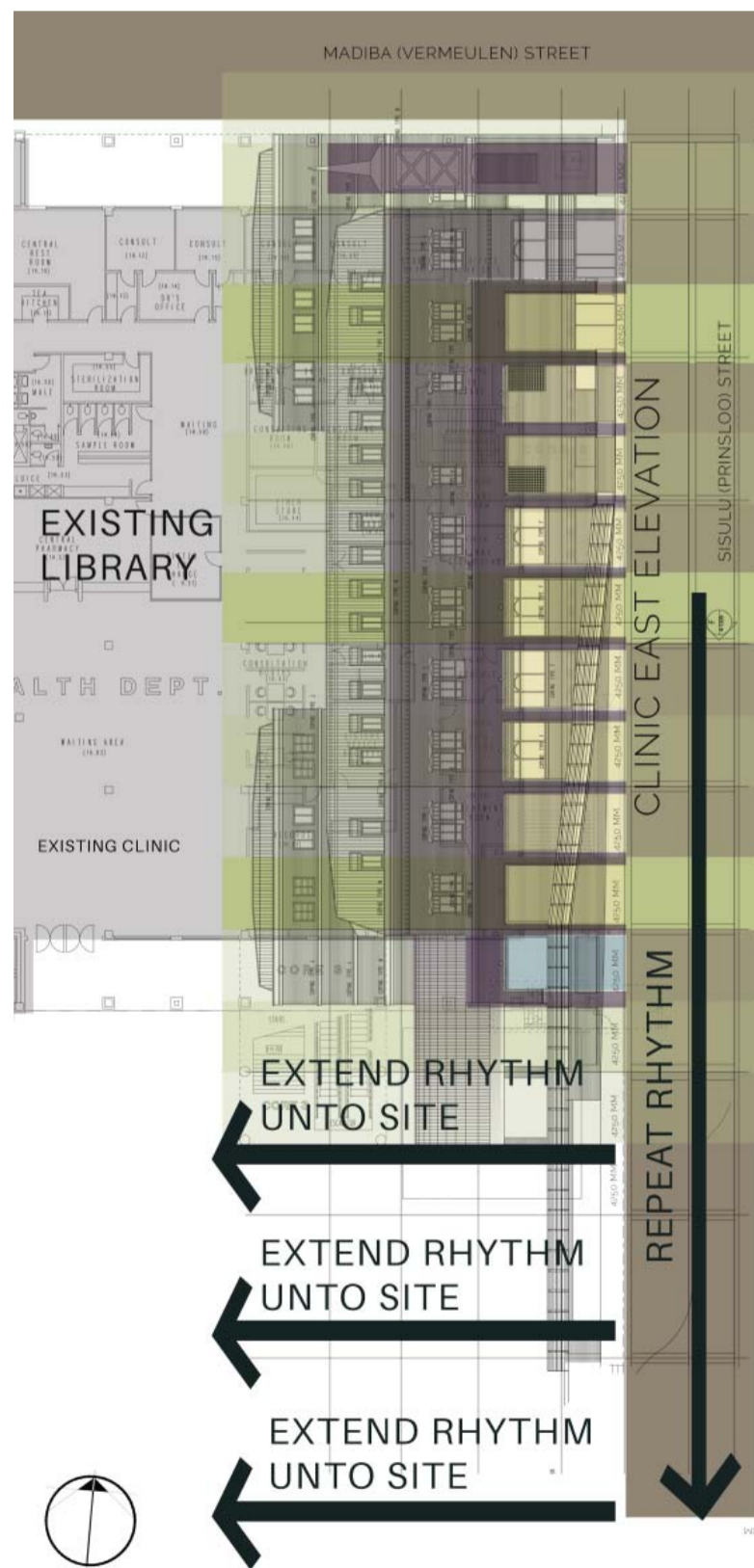

Figure 6.50 - Apply Sammy Marks Centre facade rhythm onto site.psd

Reserve Bank

The design response to the Reserve Bank is limited to its influence on scale. The new intervention brings the scale up to the level of the historic Church Street city scale.

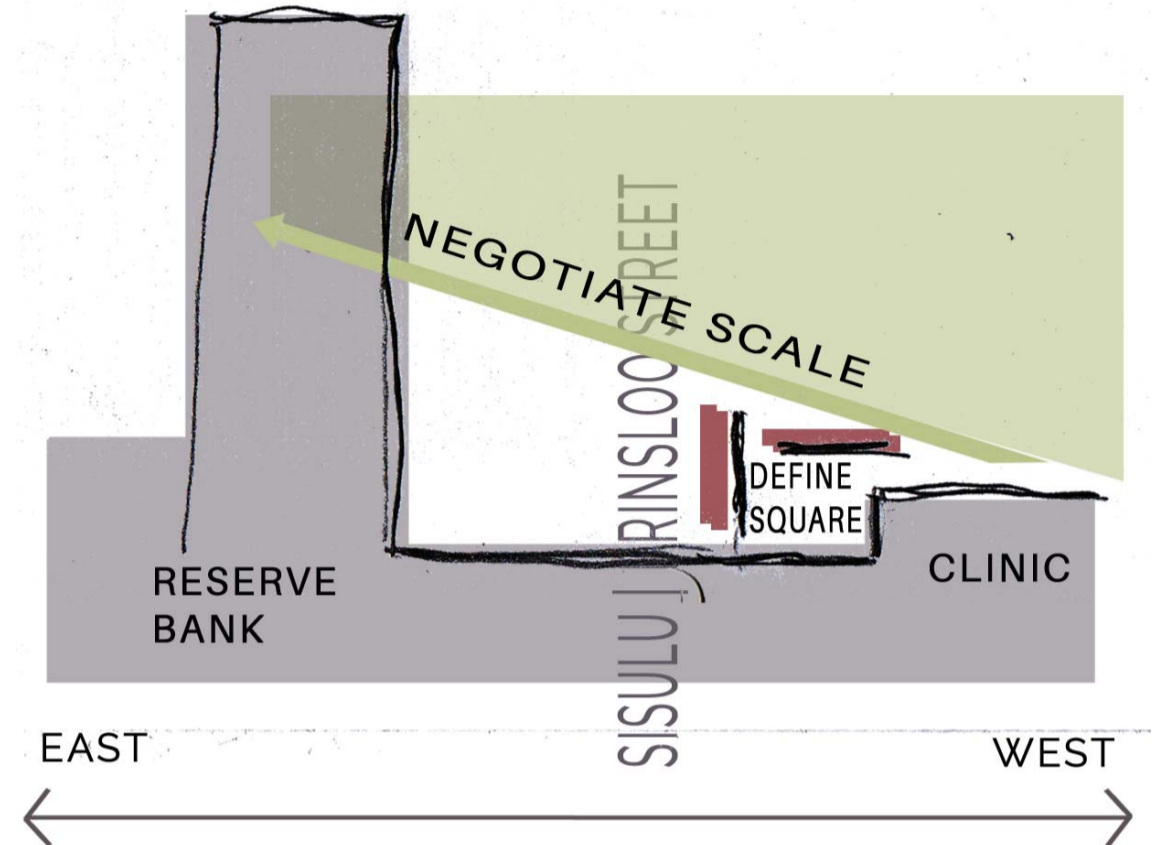

Figure 6.52 - Response to Reserve Bank building.psd

Urban Forest

As explained previously the Urban Forest becomes the antithesis of the Urban Built condition. The design response towards it is that the edge, created to define the square, becomes the mediator between the Urban Built condition and the Urban Forest.

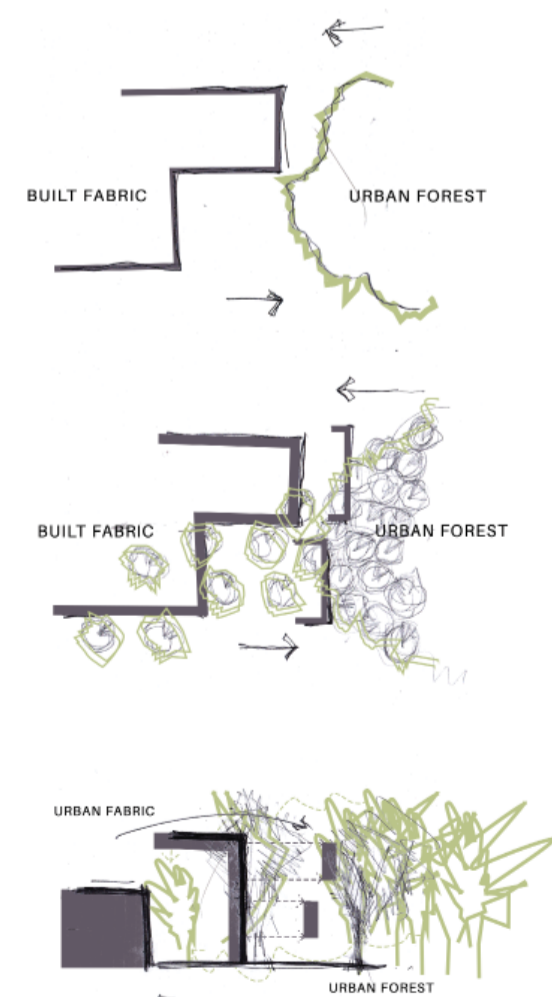

Figure 6.51 - Concept diagram - Urban Built versus Urban Forest.psd

Material responses

Stone, concrete, brick, steel and glass are the material conditions discussed earlier. The specific design response to them will be discussed below.



Figure 6.53 - Slate floor surfaces.psd
("LANTIC COLONIAL by Porcelanosa" 2015)

Stone

Sandstone, granite and shale are the only quarried materials in their natural form currently on site. Only shale will be specifically responded to. In order to strengthen the memory of the water furrows (built with shale) the shale will be used in the showers and the wet steam rooms of the public ablutions.

Concrete

The State Theatre's béton brut are referenced in the new amphitheatre. It is a structure completely built with in situ cast concrete.



Figure 6.54 - Concrete amphitheatre.psd (Sanjuan n.d.)

Brick



Figure 6.55 - Brick wall.psd
(James Bo Insogna n.d.)

The Gundelfinger building is the conceptual anchor to the Urban Built condition and its red clay bricks are very significant. It is therefore the material on site with the greatest gravity. Brick is therefore the material that will communicate the Urban Built condition in the design. The brick wall becomes the wall that supports the colonnade or stoep. Moreover, reminiscent of the Roman aqueduct it becomes the structure that supports and serves the public ablutions.

Steel

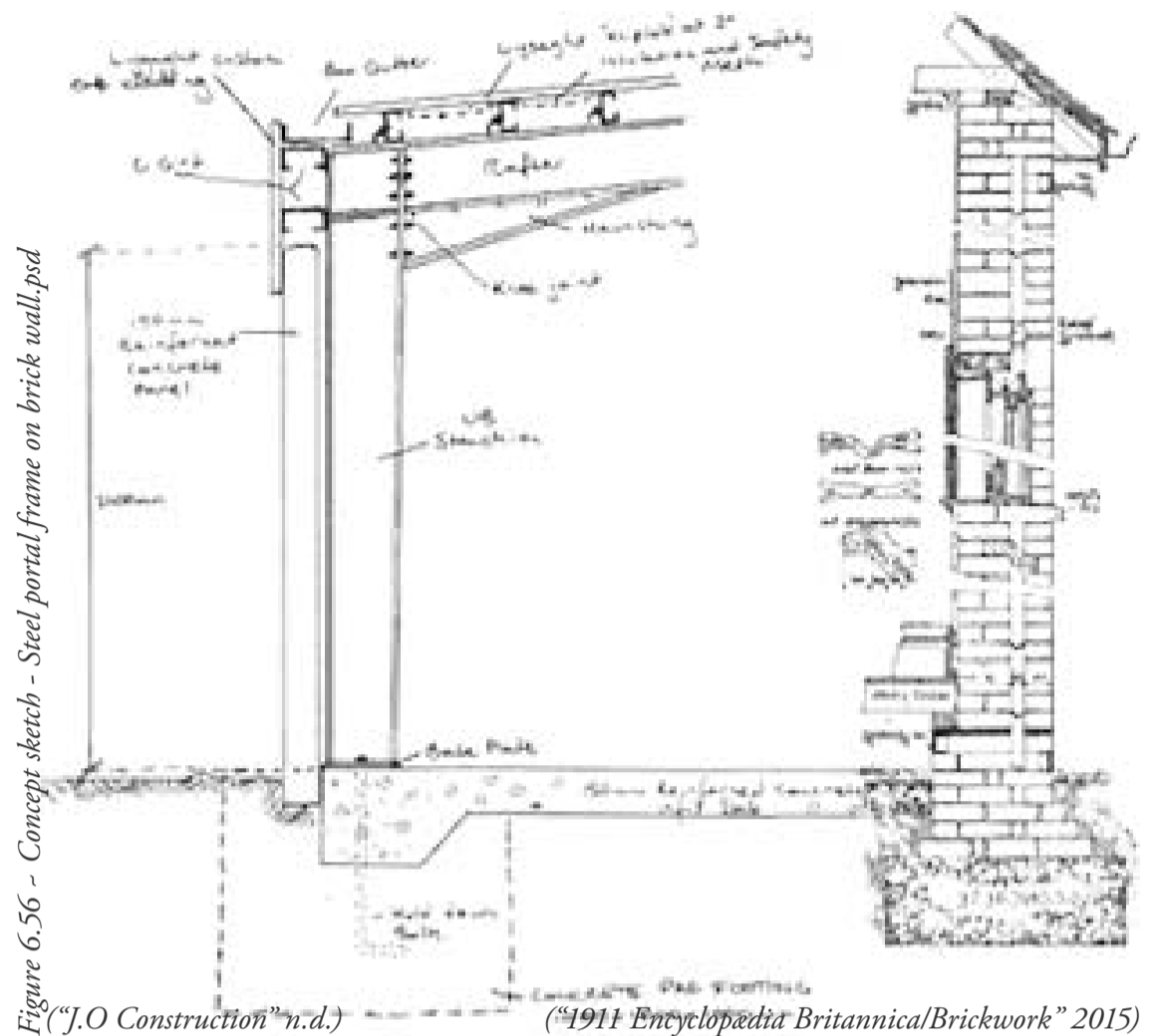

Figure 6.56 - Concept sketch - Steel portal frame on brick wall.psd
("J.O Construction" n.d.)

The steel arches on site are incorporated into the new design. As with wood, steel can be joined and assembled. It is therefore the more appropriate material to use as structural system for the translation of the Urban Forest condition.

Glass

The black glass used on the South African Reserve Bank will be used for glazing on the east and west façades of the design where vertical louvres will block direct sun. The black glass will still be visible from the south (louvres angled at 112° according to Pretoria's azimuth on summer solstice).



Figure 6.57 - Black glass.psd
("The World's most recently posted photos of steilneset" n.d.)

Circulation Responses

Specific design responses to the arcades, the streets and the basements

Arcades

Pretoria's arcades are a vital part of the city's character. It provides a network of shortcuts that breaks the long east-west façades of the city block. These arcades create the opportunity for an intimate human scaled space. The arcades were also implemented in the 1994 design of the Sammy Marks Centre. The strengthening thereof was one of the conclusions of the urban vision. The design aims to not only investigate the effect of the arcade on the ground but hopes to evolve it into arcades that connect the higher levels of the city as well.

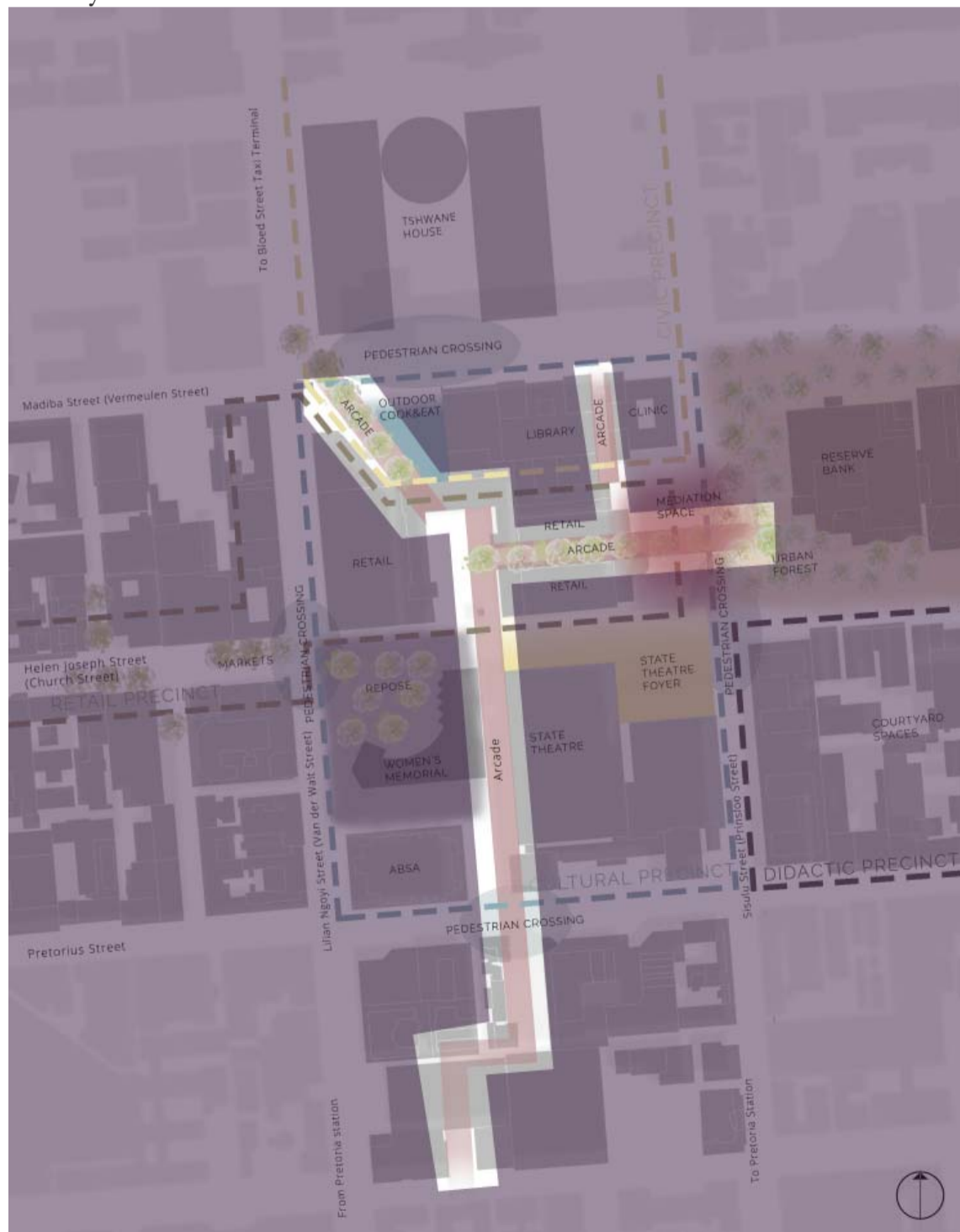
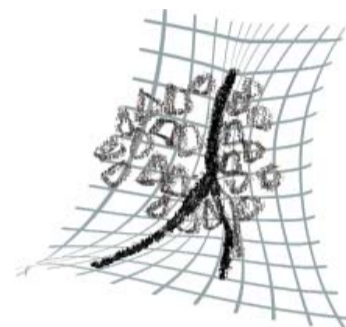
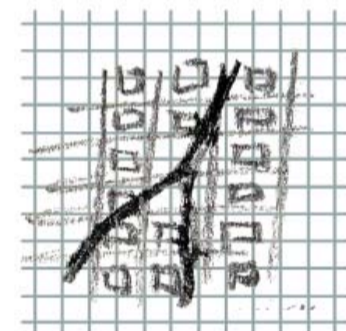

Figure 6.58 - Arcades on site.psd



TRADITIONAL TOWN DEVELOPMENT



MODERN TOWN DEVELOPMENT

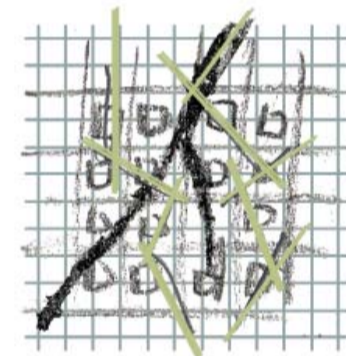

ARCADE DEVELOPMENT

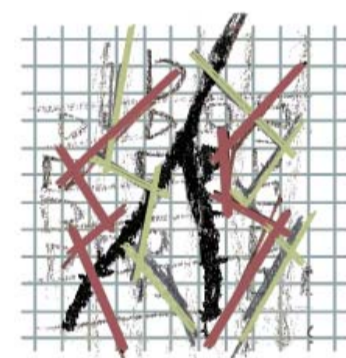

SKY ARCADES

Figure 6.59 - Arcade development on plan.psd

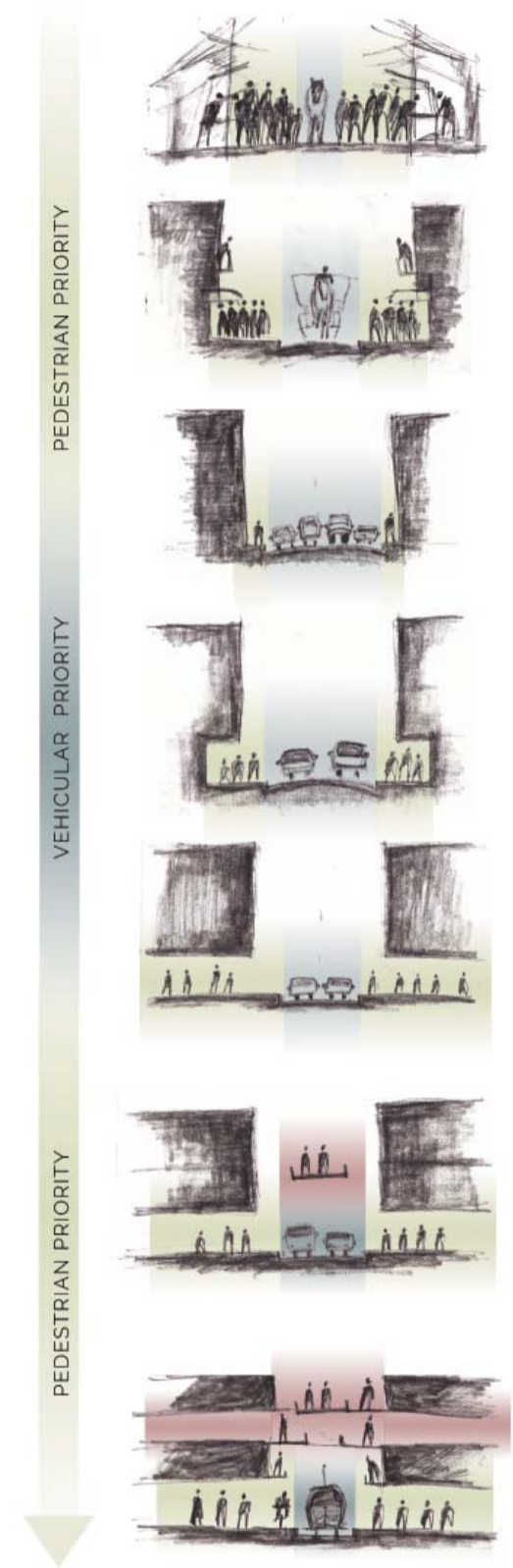

Figure 6.60 - Arcade development on section.psd

Streets

In the urban vision it was decided that specially designed pedestrian crossings with appropriate surface material and traffic control systems were the only way to prioritise the pedestrian in this busy part of the city. In this design a further measure is taken to communicate the ranking of the pedestrian in the hierarchy. It is done by changing the street surface from Madiba (Vermeulen) Street all the way to Pretorius Street and by inserting an island of trees that will not only provide additional green spaces, but also supports the concept of the Urban Forest spilling out into the rest of the city.

Basements

The basement parking under the Sammy Marks centre is badly lit and circulation for pedestrians is obscured. The decision to sink the courtyard and amphitheatre to lower levels was mainly done to keep the ground level clear on the eye level of the pedestrian. However flooding the basement with light makes it more accessible and visible.

Environmental responses

The main responses to the solar conditions include solar shading. The structure's orientation creates very large eastern and western façades and vertical louvres with angles of 112°E on the eastern façade and 112°W on the western façade are crucial.

Further desing development

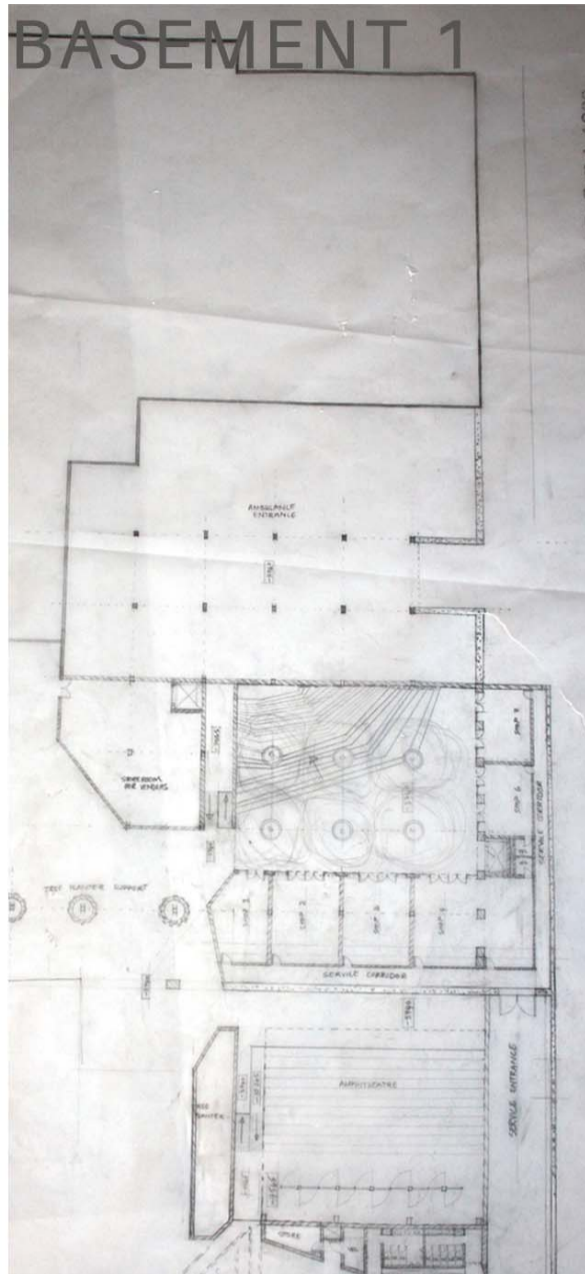

Figure 6.61 - Design development - Basement 1 floor plan.psd

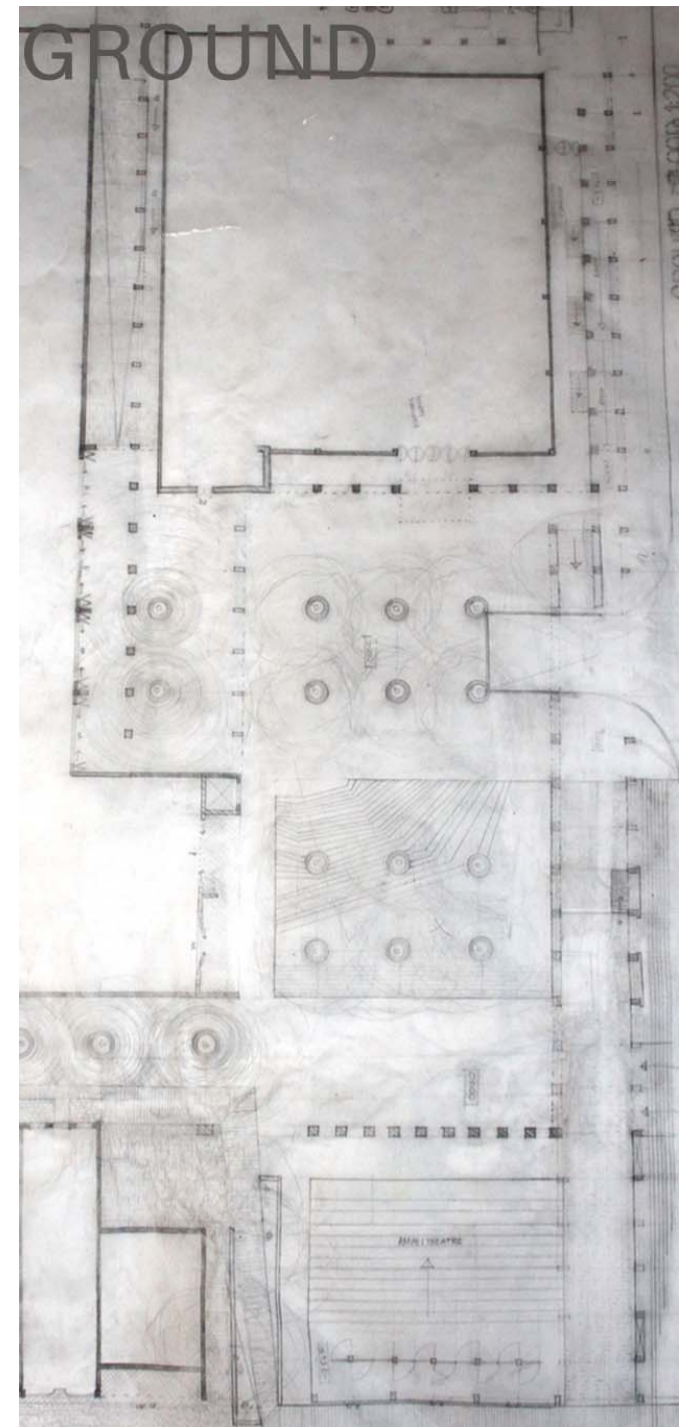

Figure 6.63 - Design development - Ground floor plan.psd

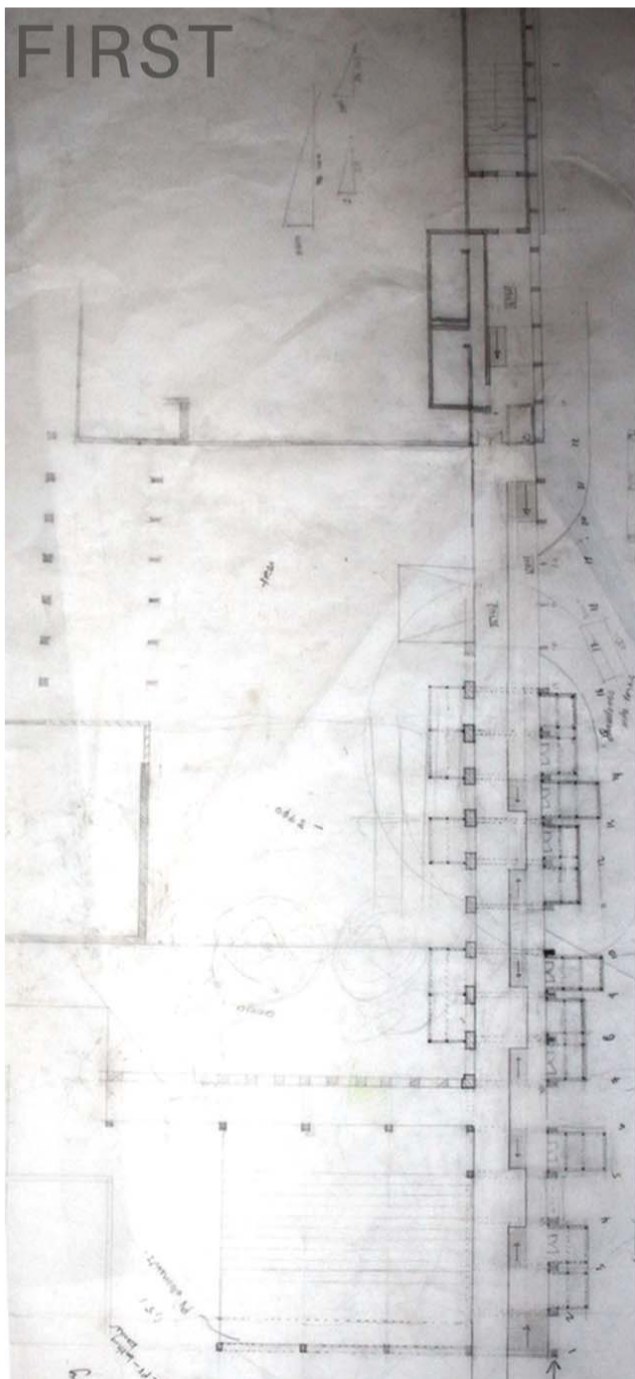

Figure 6.62 - Design development - First floor plan.psd

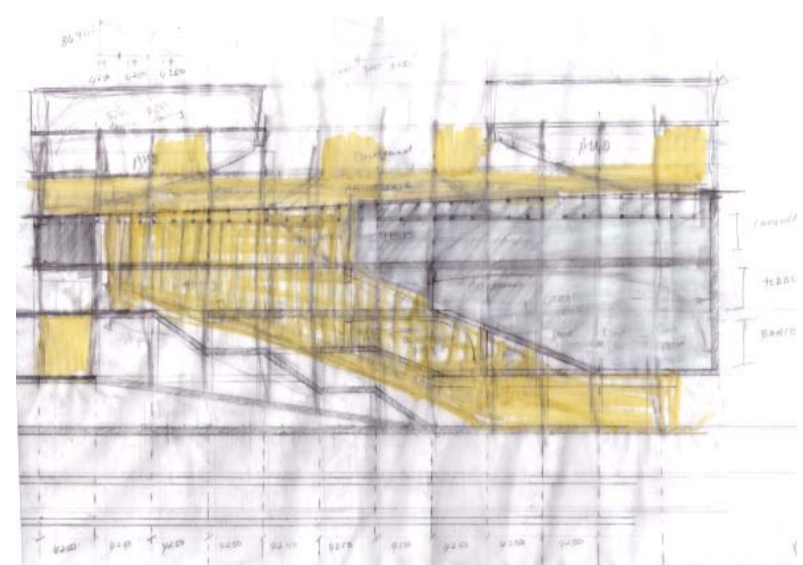

Figure 6.65 - Design development - Clinic addition.psd

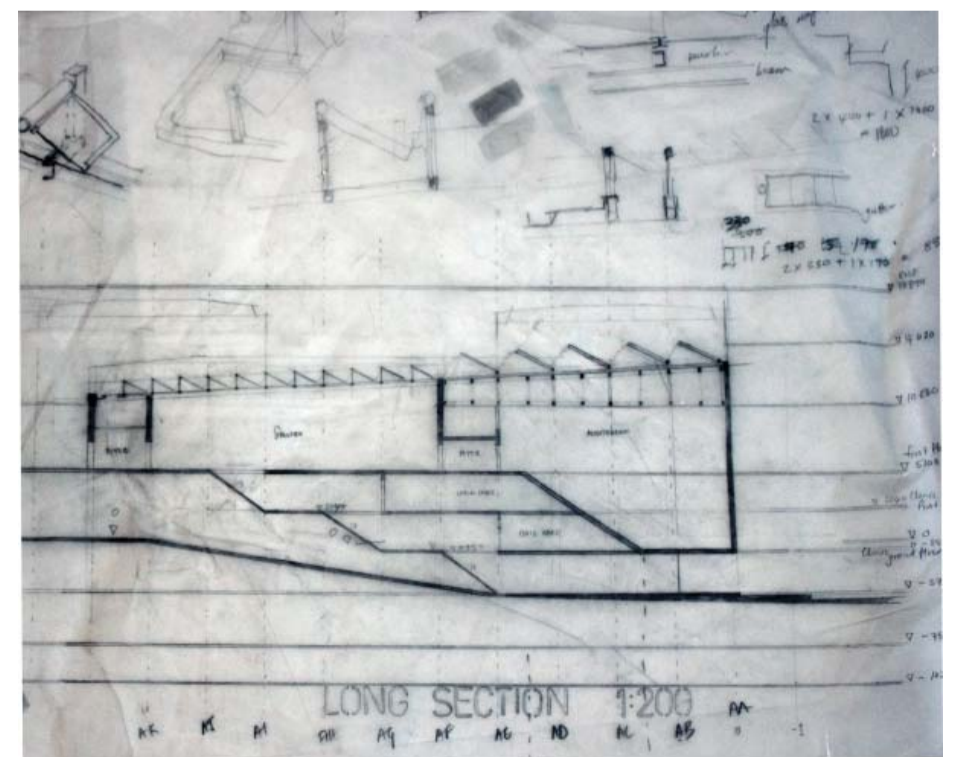

Figure 6.64 - Design development - Clinic section.psd

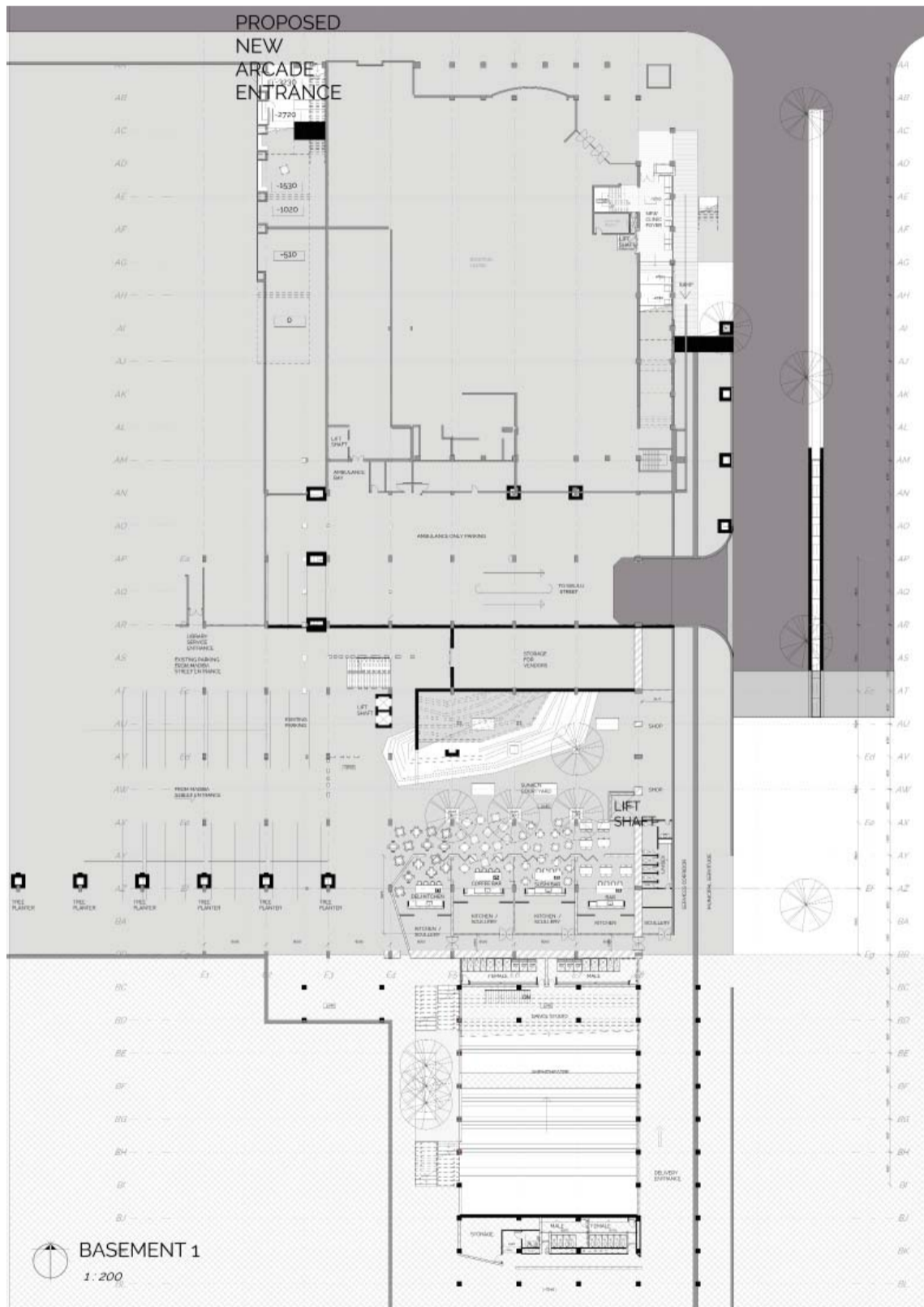

Figure 6.66 - Plan development - Basement 1.psd

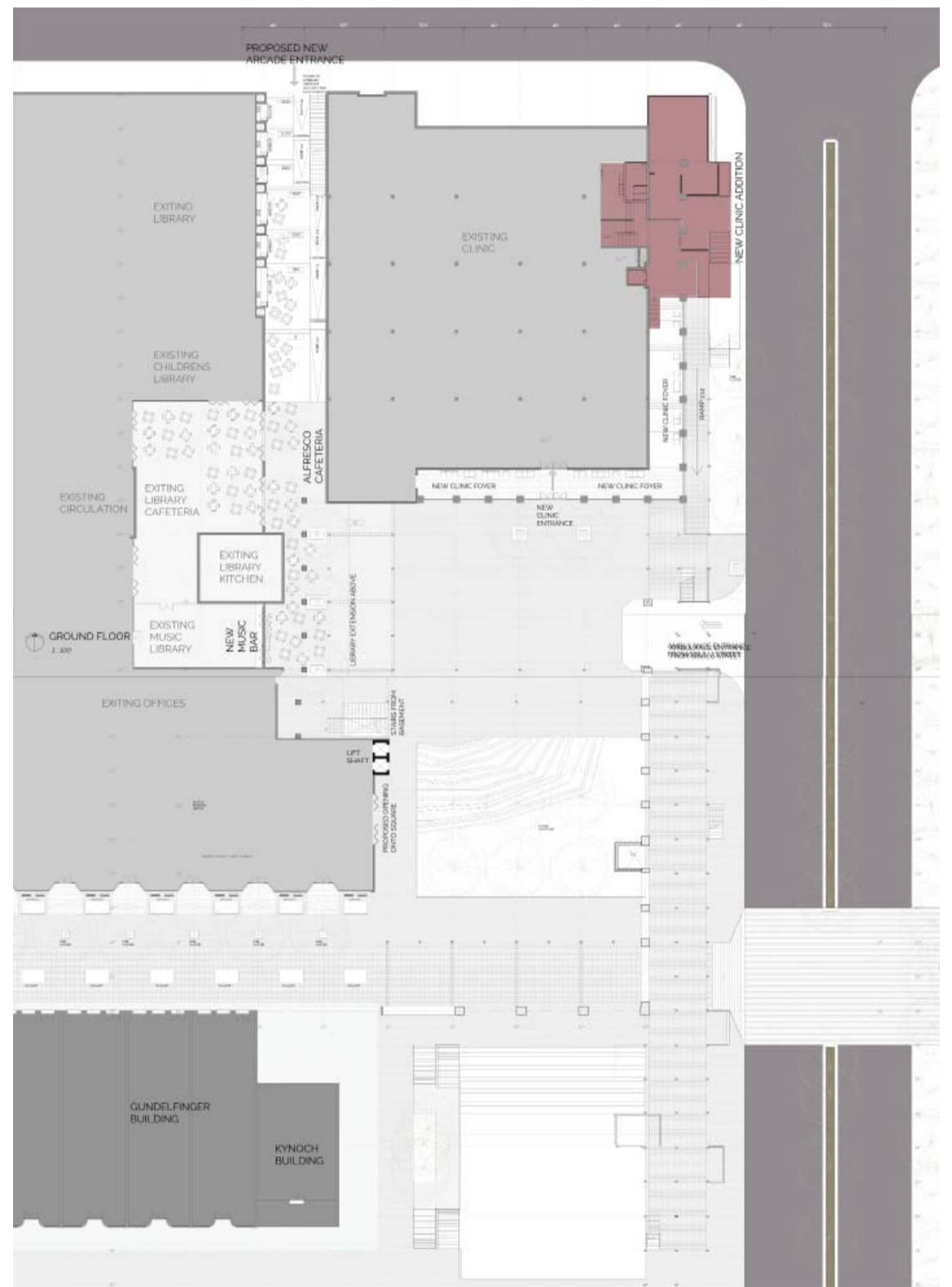

Figure 6.67 - Plan development - Ground floor.psd

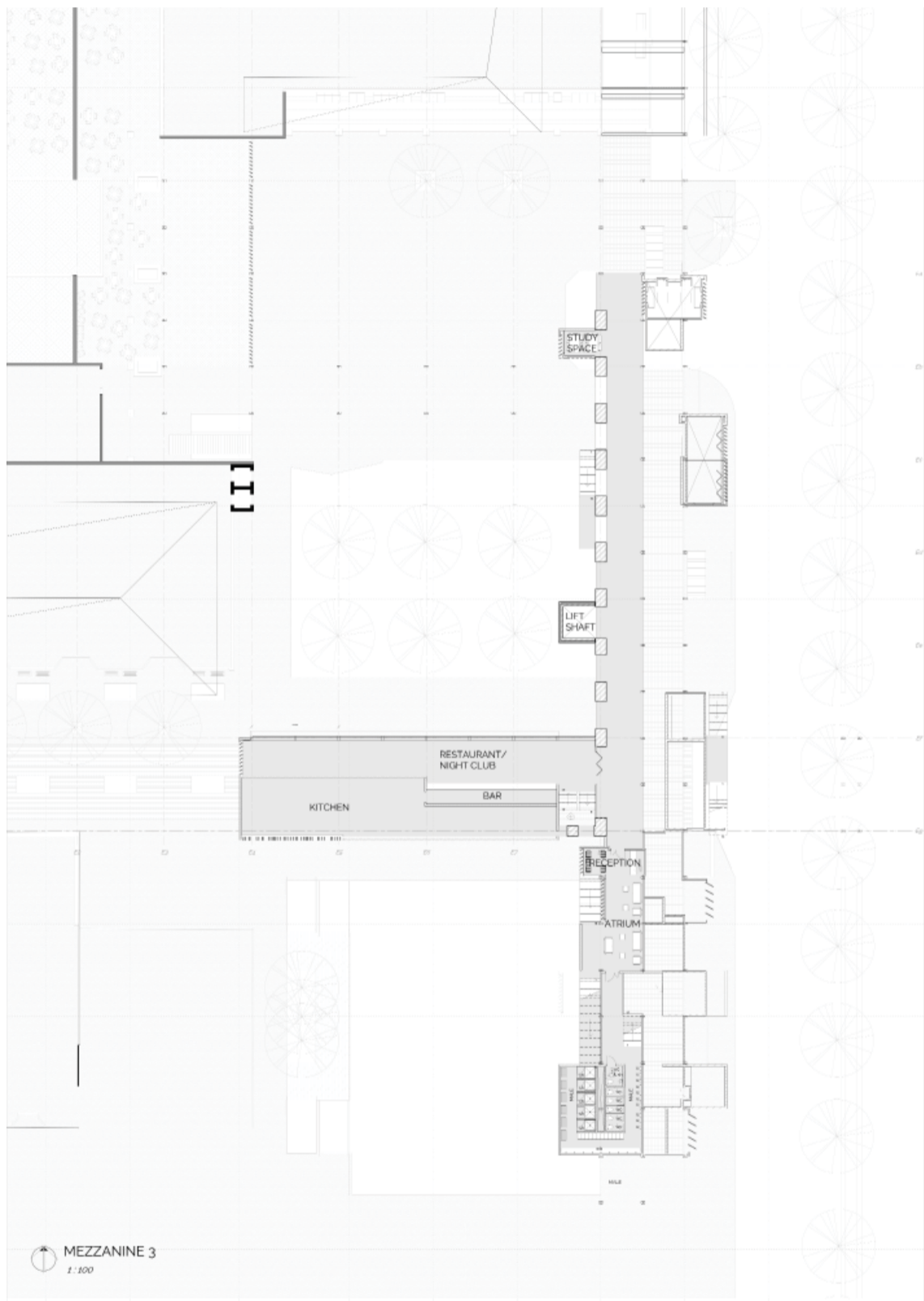

Figure 6.68 - Plan development - Mezzanine 3.psd

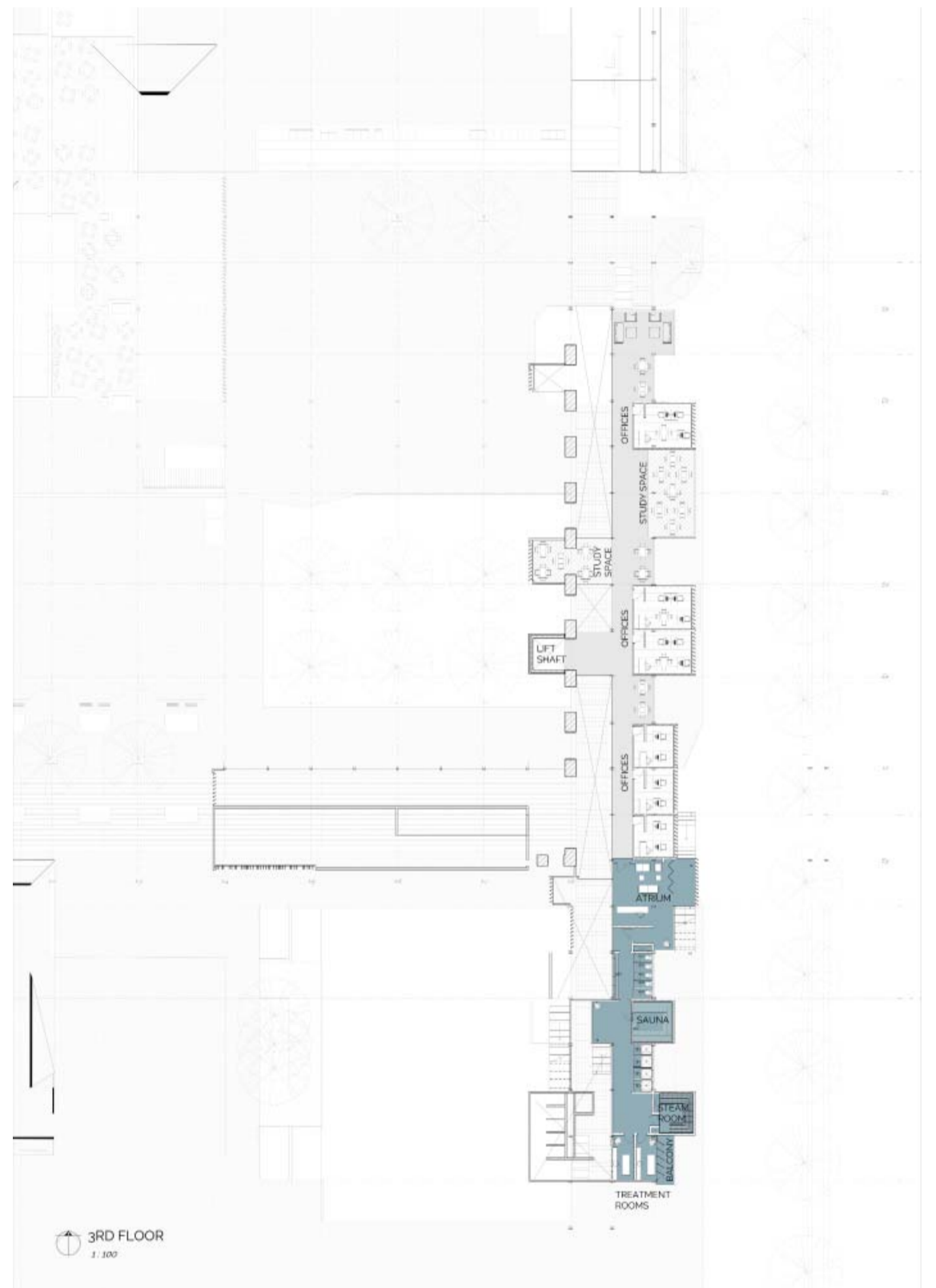

Figure 6.69 - Plan development - Third floor plan.psd

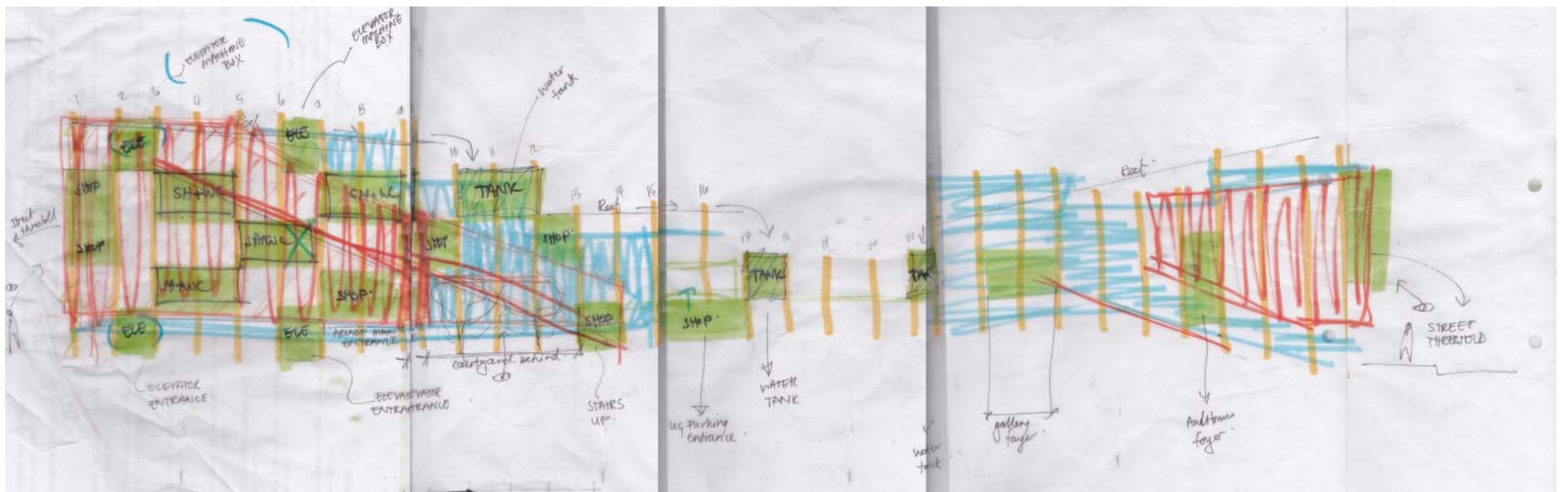

Figure 6.70 - Programme development on elevation.psd

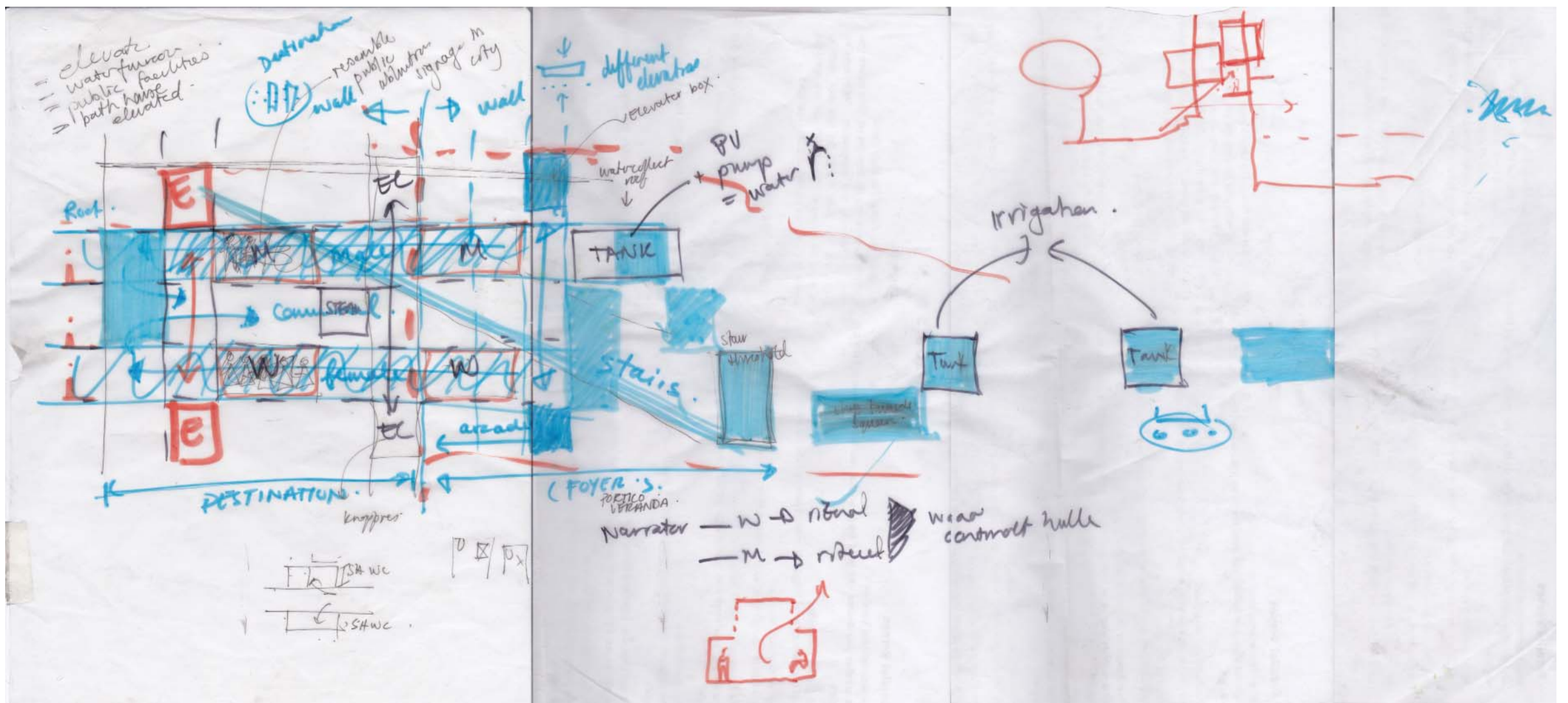
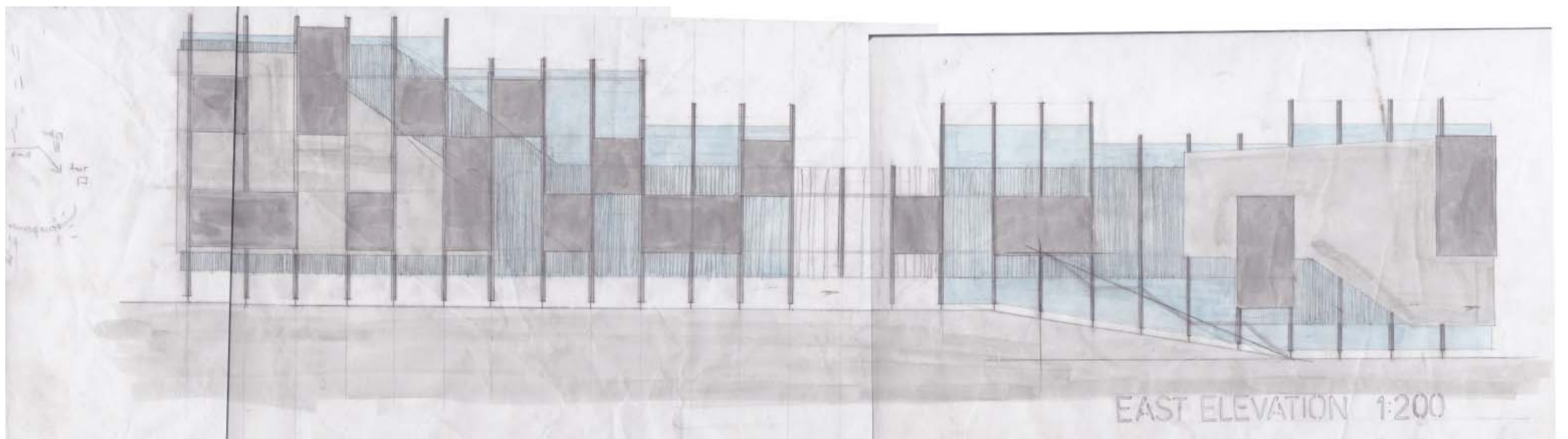
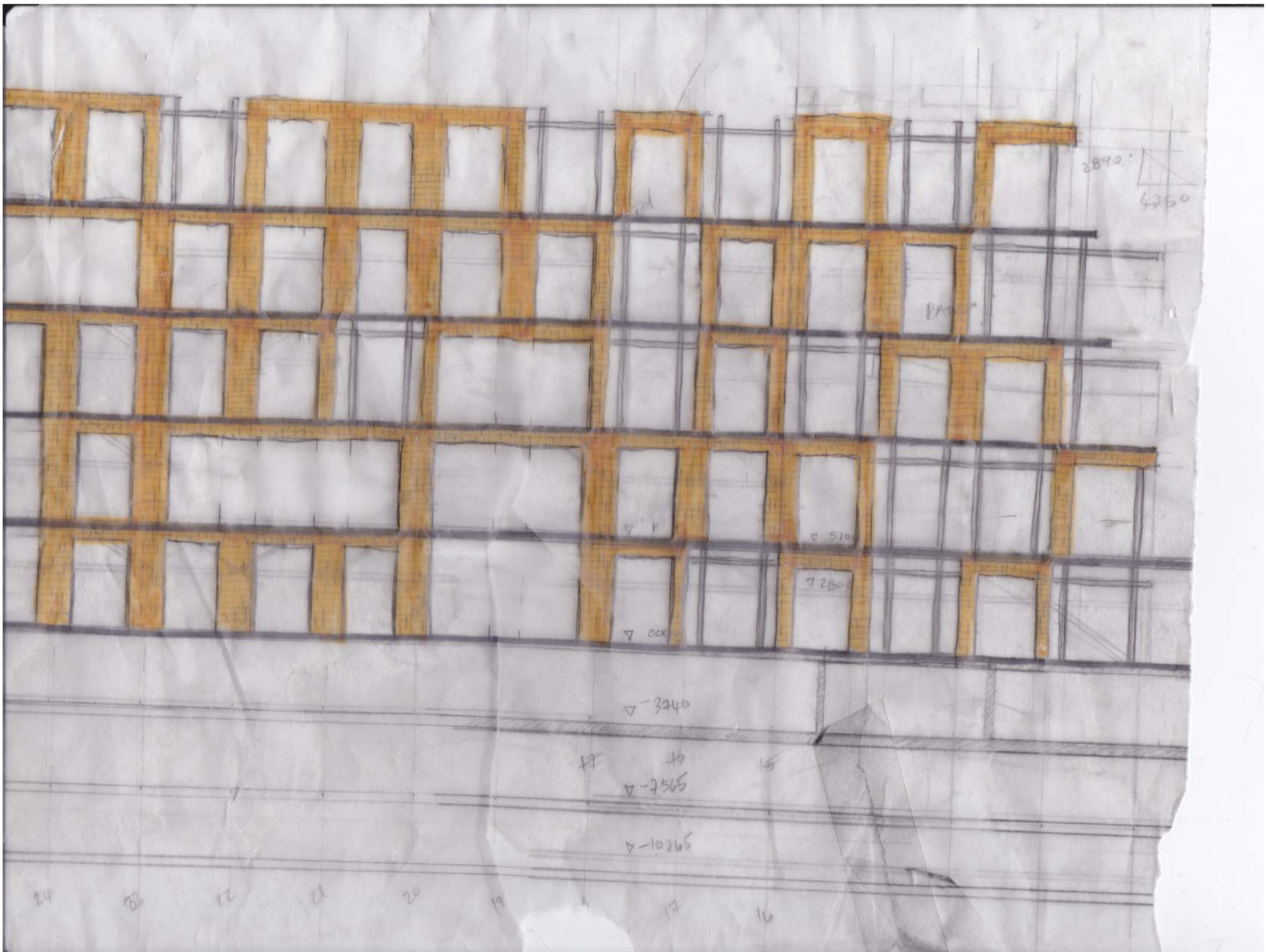

Figure 6.71 - Design development - water system on elevation.psd

Elevation design







© University of Pretoria

“When we look at the finished building, our eyes, guided by our analytical mind, tend to stray and look for details to hold on to. But the synthesis of the whole does not become comprehensible through isolated details. Everything refers to everything. ~Peter Zumthor (Zumthor, 2010:26)