

RECALIBRATING VOID

[DESIGN PHASE]

6

DESIGN DEVELOPMENT	113
MADIBA ART PRECINCT CLIENT	130
MADIBA ART PRECINCT PROGRAMME	131
FIGURE REFERENCES	133

“Architecture is a confluence of cultural, political, and ethical decisions that occurs in an estuary of broad societal currents; thus, ever-changing, it encompasses the aesthetic, the tectonic, and the functional, the urban and the global –

and now the sustainable.”

- Thom Mayne, Morphosis

[<http://morphopedia.com/projects/san-francisco-federal-building>]

EXPLORATION THROUGH DRAWINGS

Albeit of great influence, the theoretical component of the design and implementation thereof would be incomplete without the exploration of site through drawing. In order to generate form the designer must first generate a mental landscape that is not limited to the tangible realm within which the design is manifested. The generative process of design is a culmination of varying techniques, however the exploration through drawing is more prevalent in this design process than any other technique.

In keeping with the underlying theme of the investigation, each drawing alludes to the notion of recalibration. In essence, each sketch was consciously generated as a benchmark that challenged the design process and conventional design methodologies and/or outcomes. An unfolding sequence of drawings prevail in this chapter as an architectural narrative leading from larger, more unrefined scale of the urban to a smaller, more intimate scale of design detail.

Fundamentally, a macro understanding of site led to a micro understanding of site and furthermore a design that complemented both the macro and micro urban climate. The drawings are a collection of works that highlight a non-linear, circuitous design process that revels in the manipulation of form and space through ink and pencil.

Fig. 6.1
Morphosis, San Francisco Federal Building

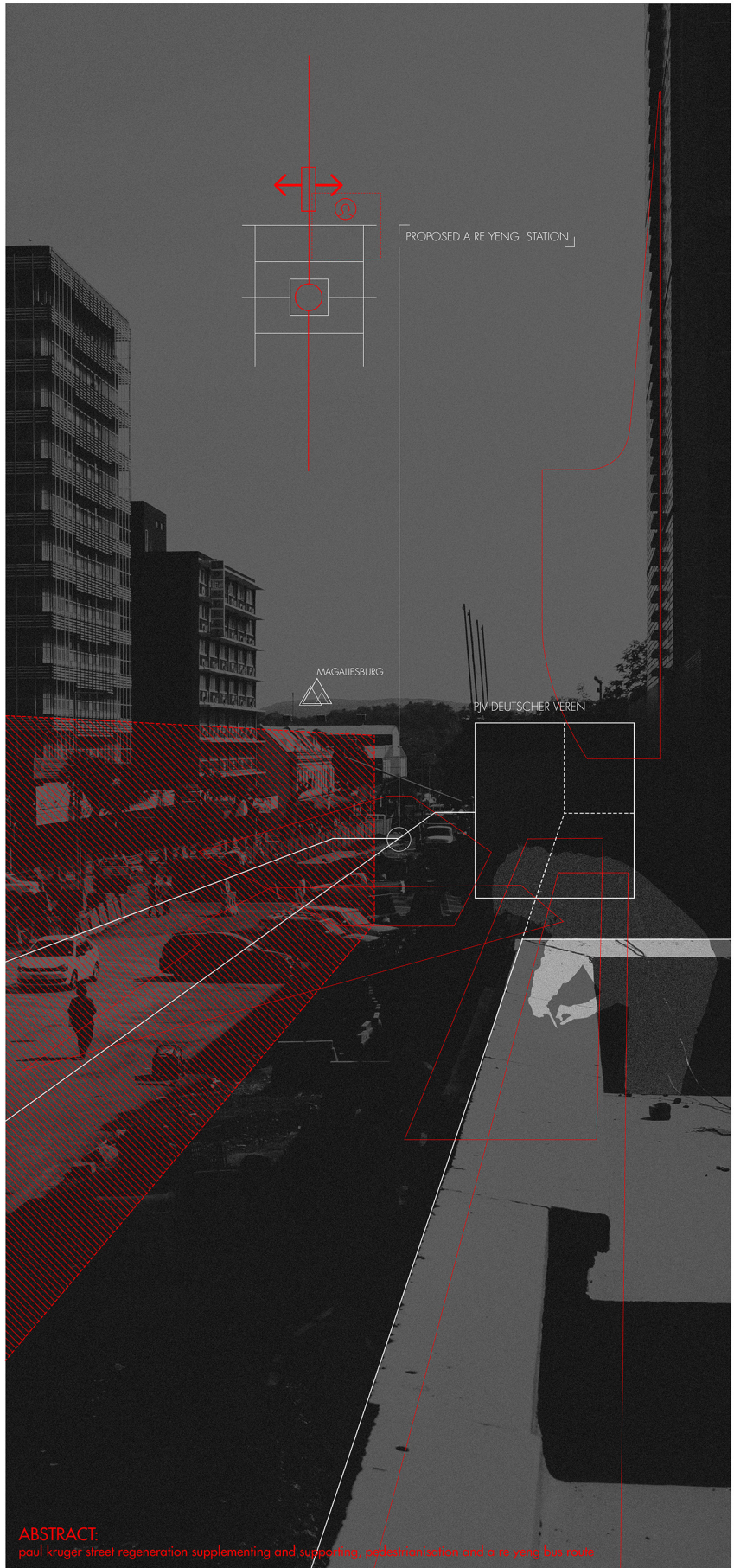

Fig. 6.2
Abstract | Street edge condition and exploration | City at Eye Level

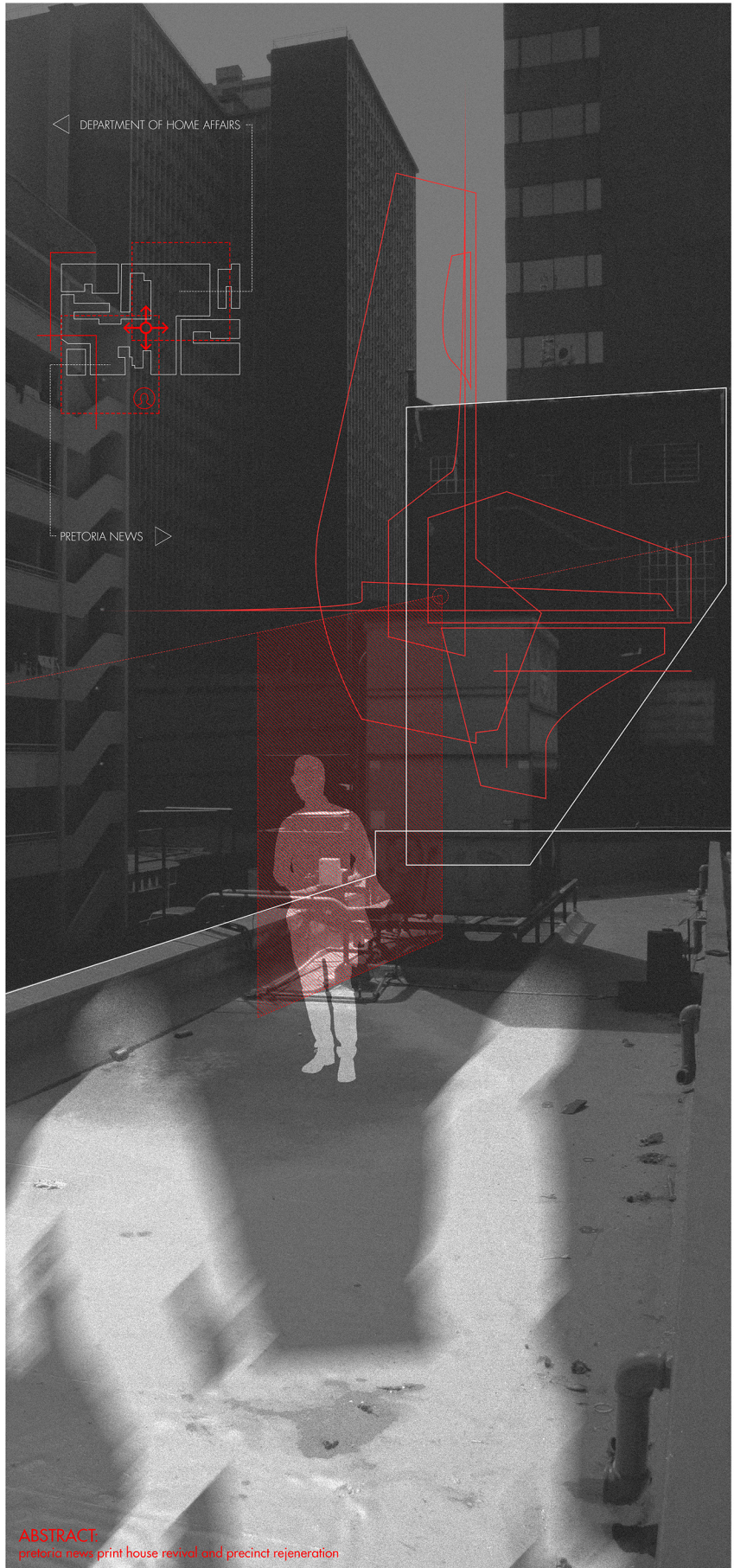
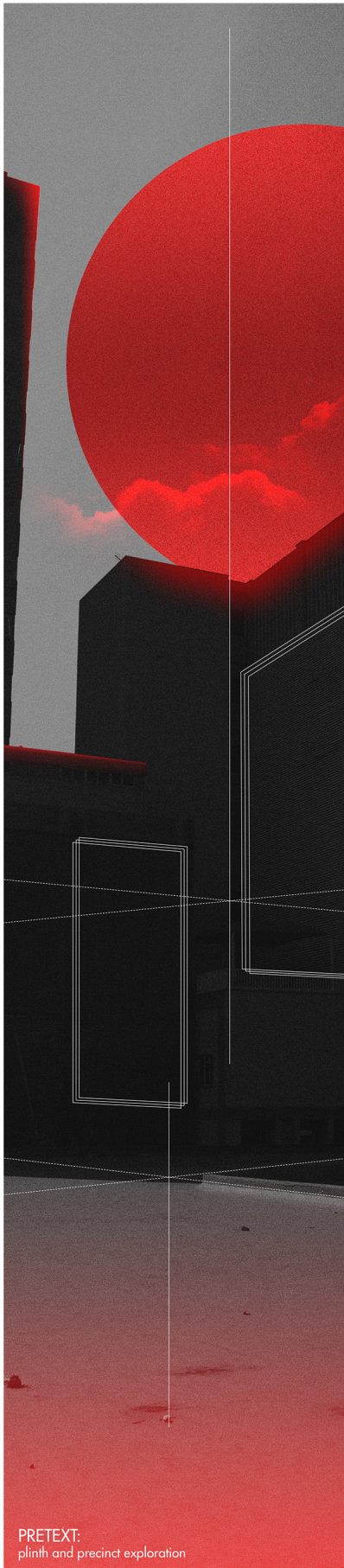

Fig. 6.3
Abstract | Plinth exploration | Hybrid plinth condition

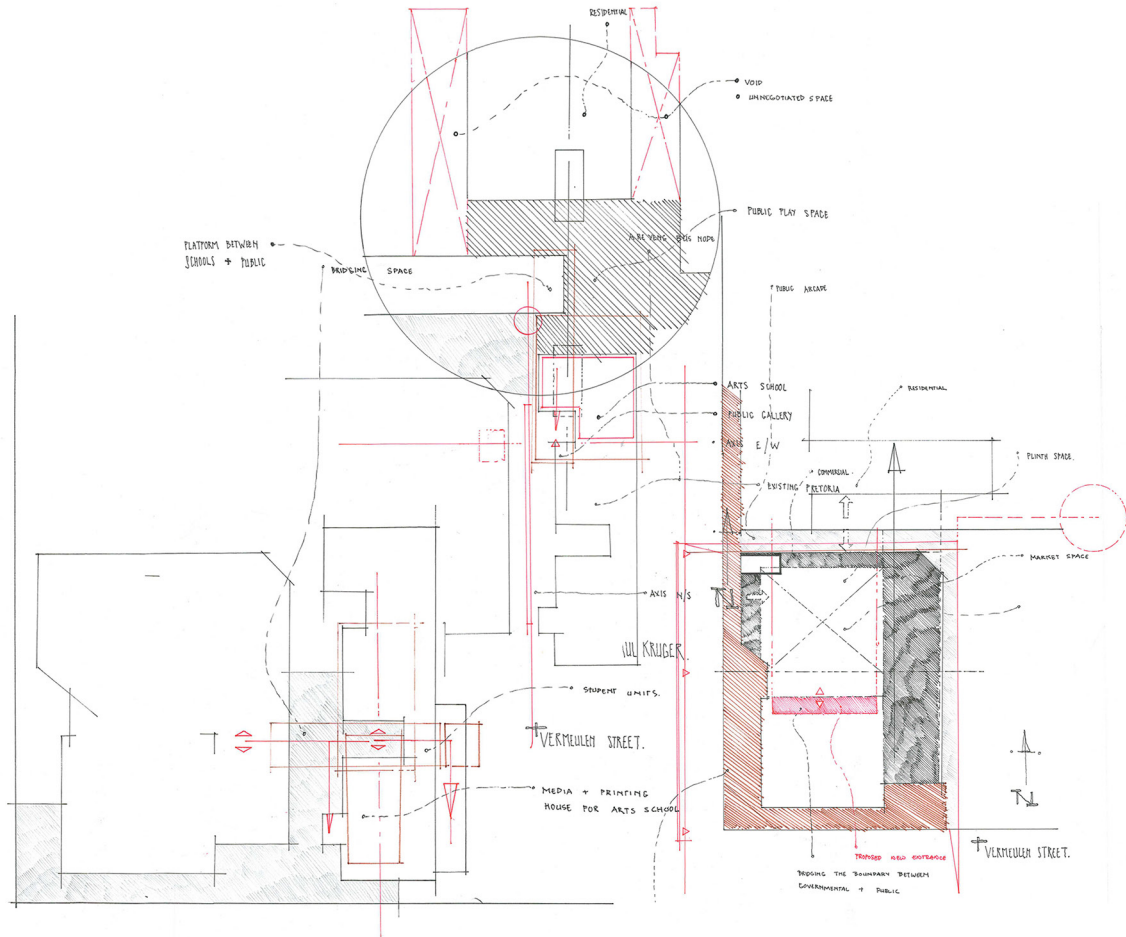
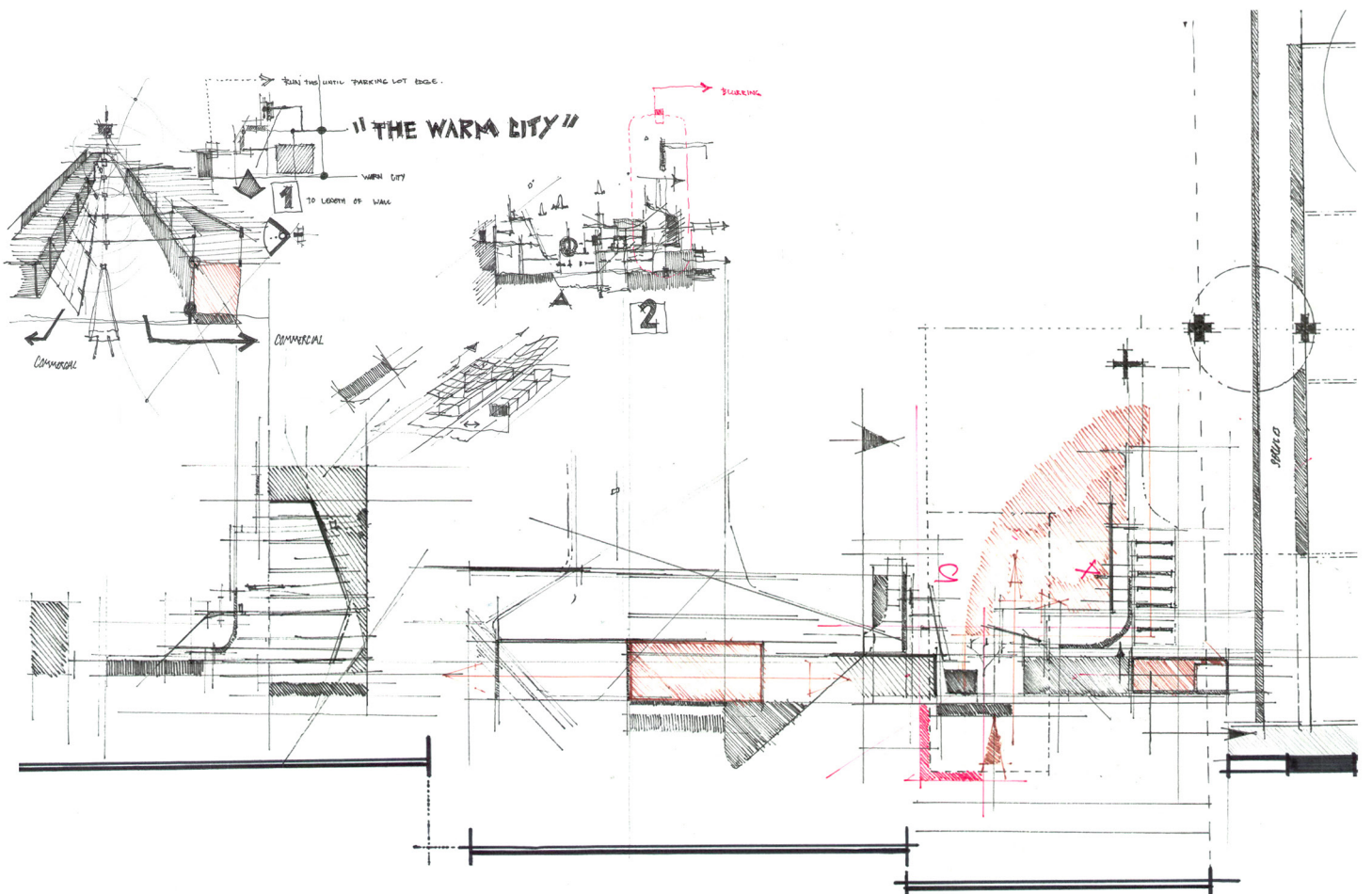

Fig. 6.4 Exploration of site | Micro urban climate



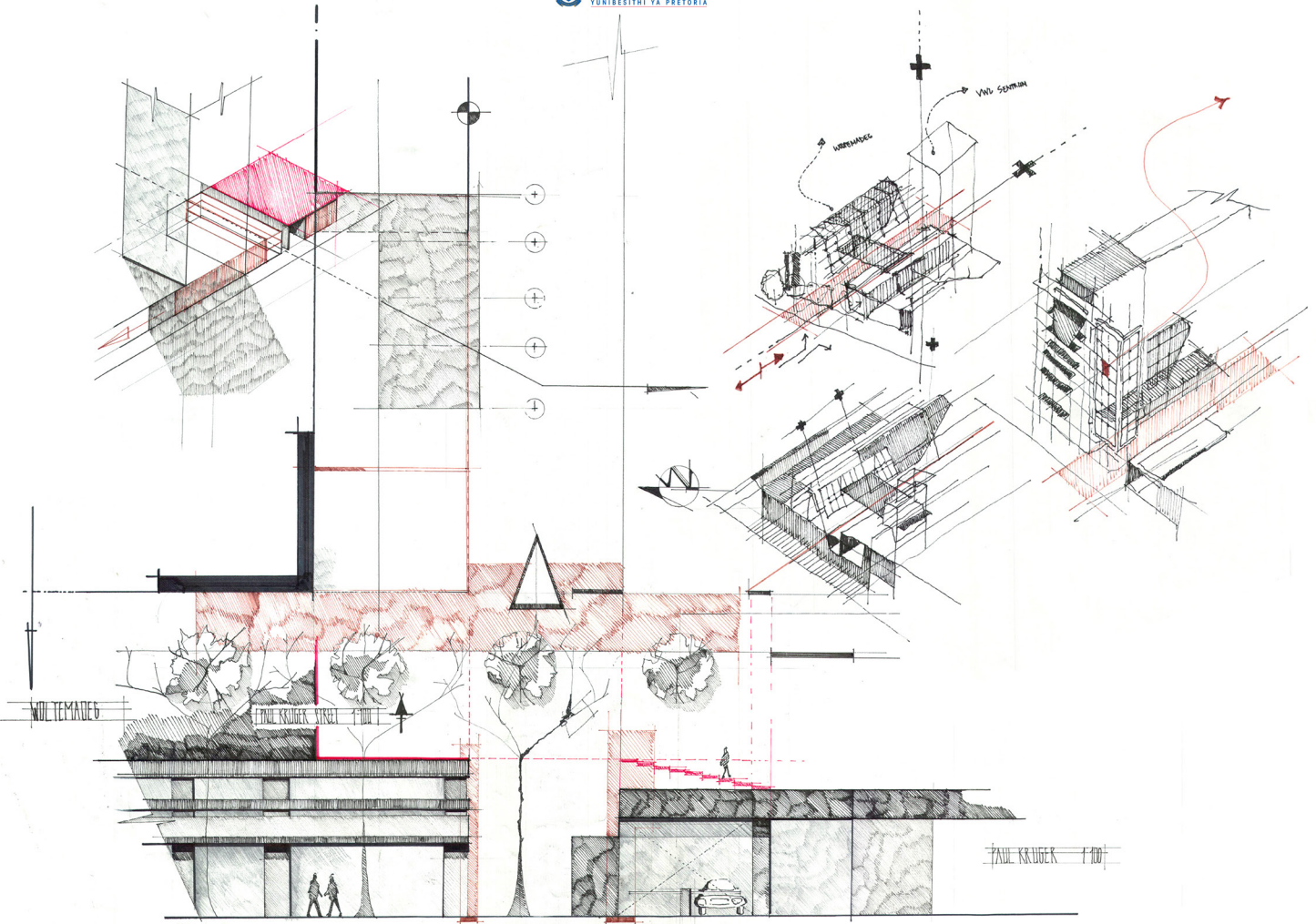
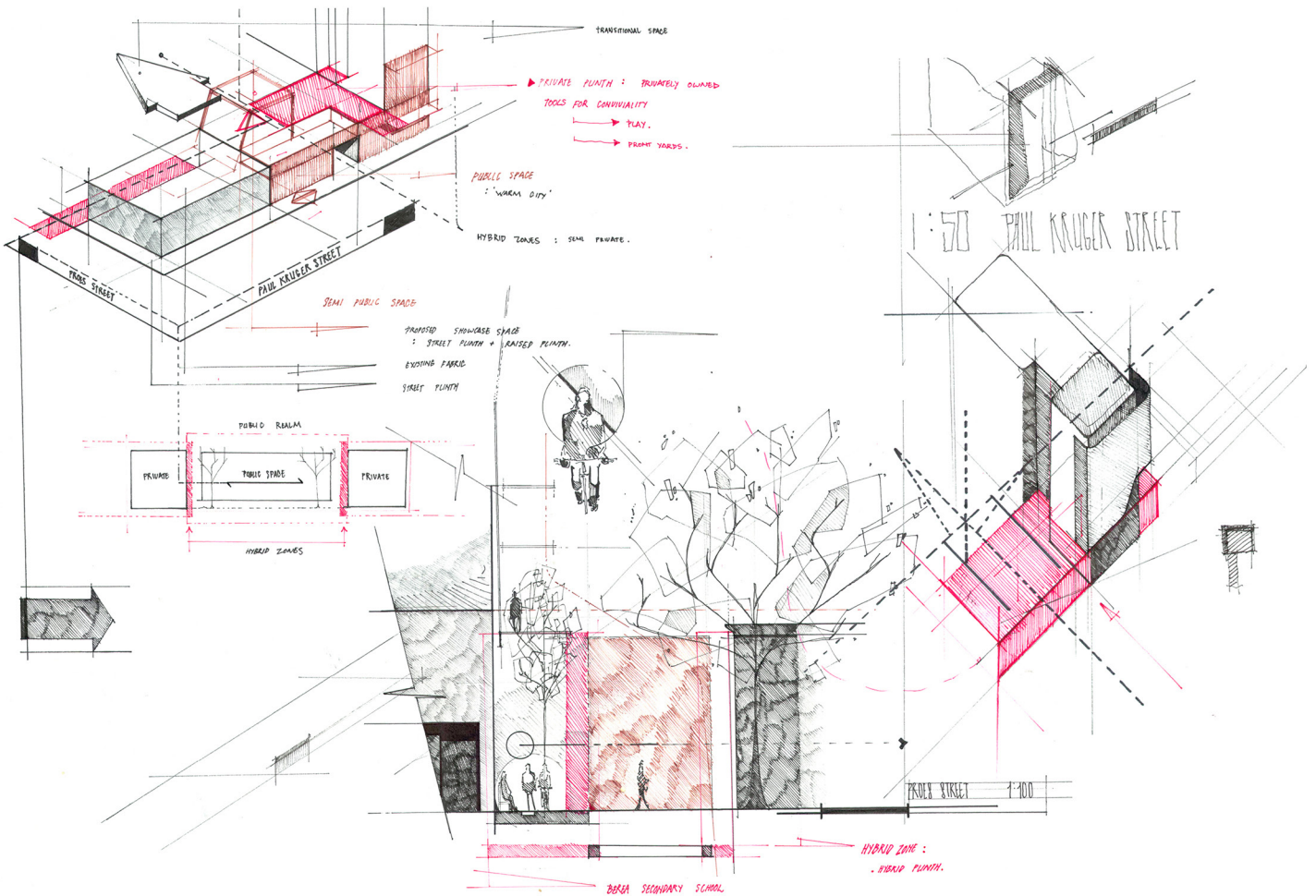

Fig. 6.5 Exploration of site | Micro urban climate



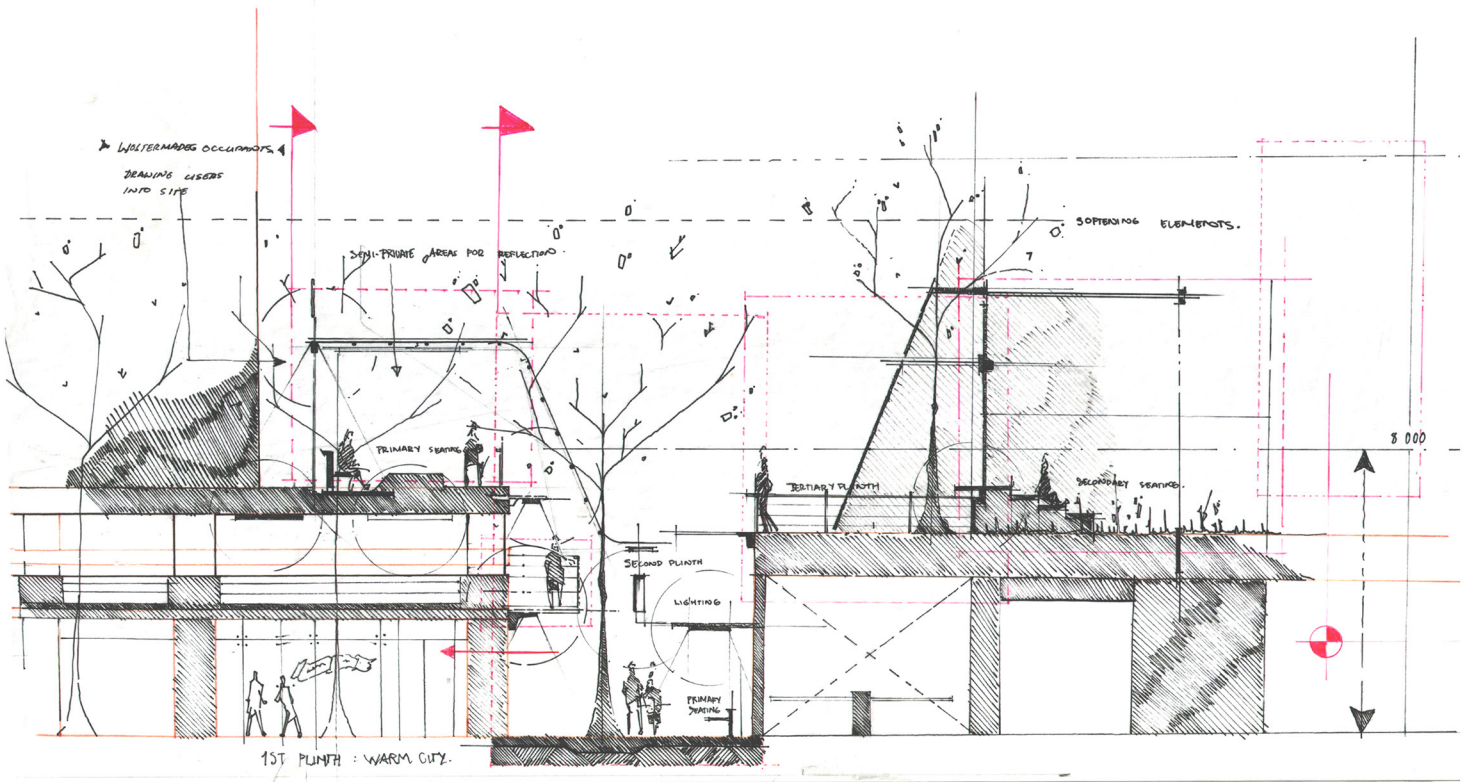
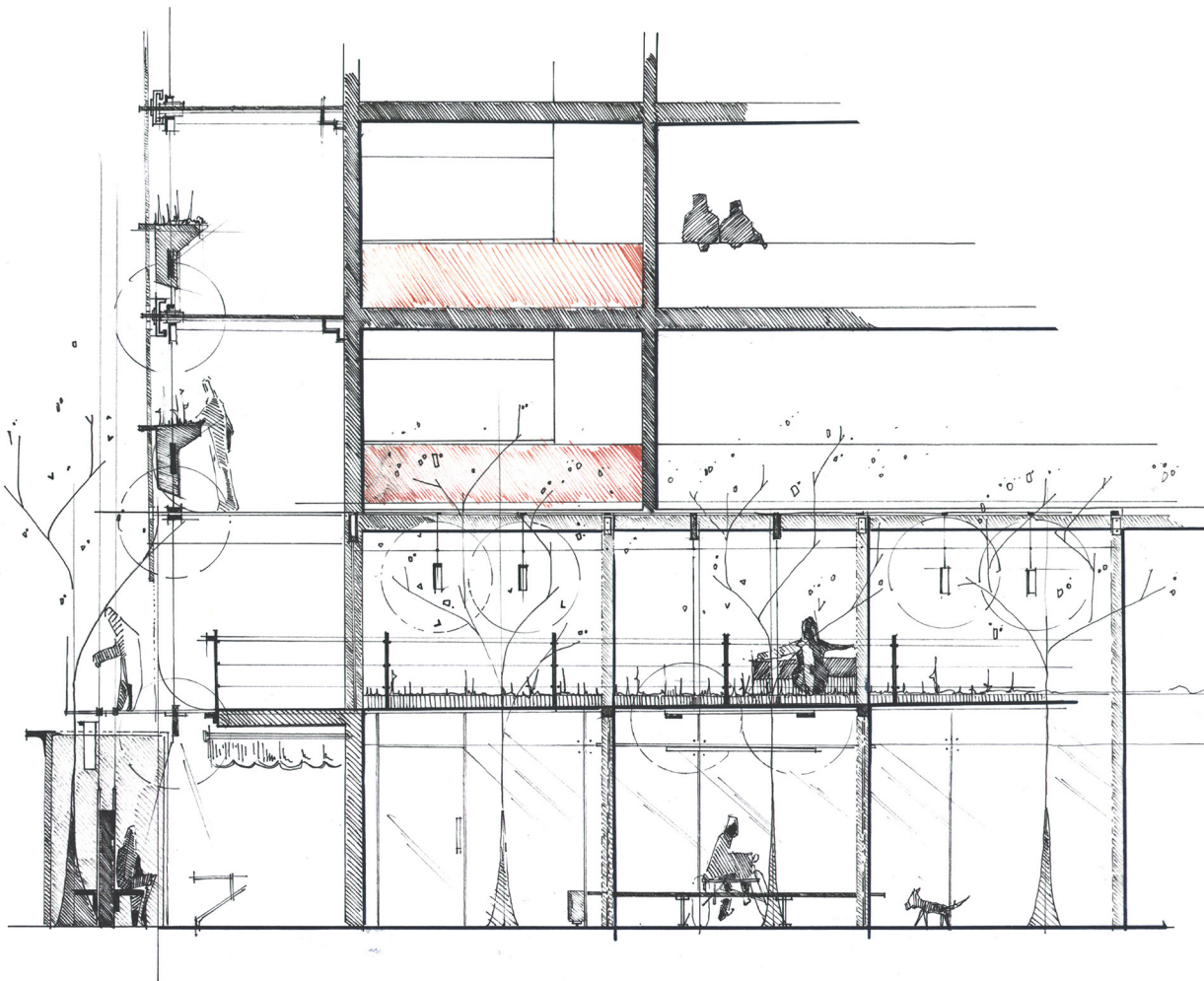

Fig. 6.6 Threshold and progression of public space from Paul Kruger Street



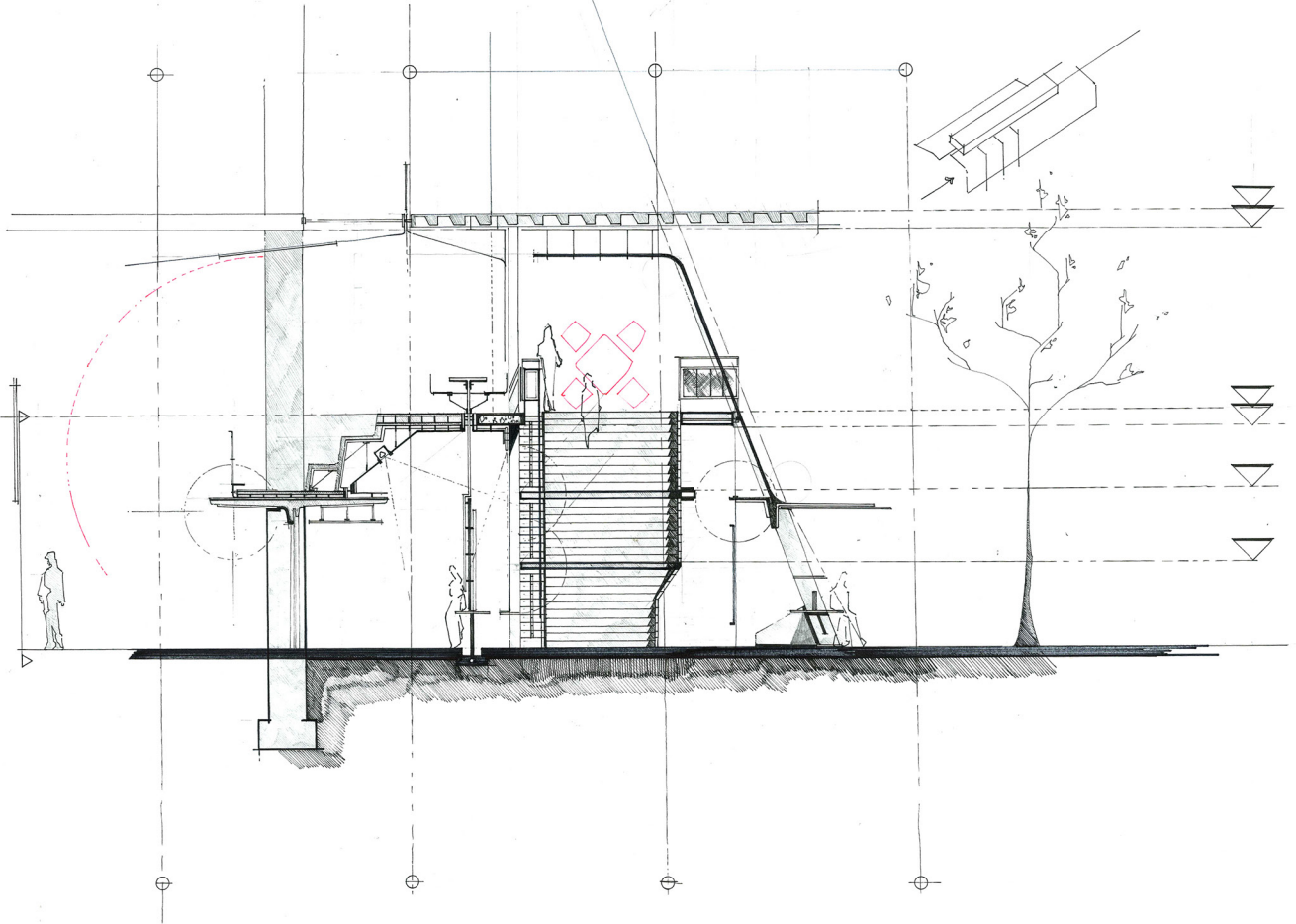
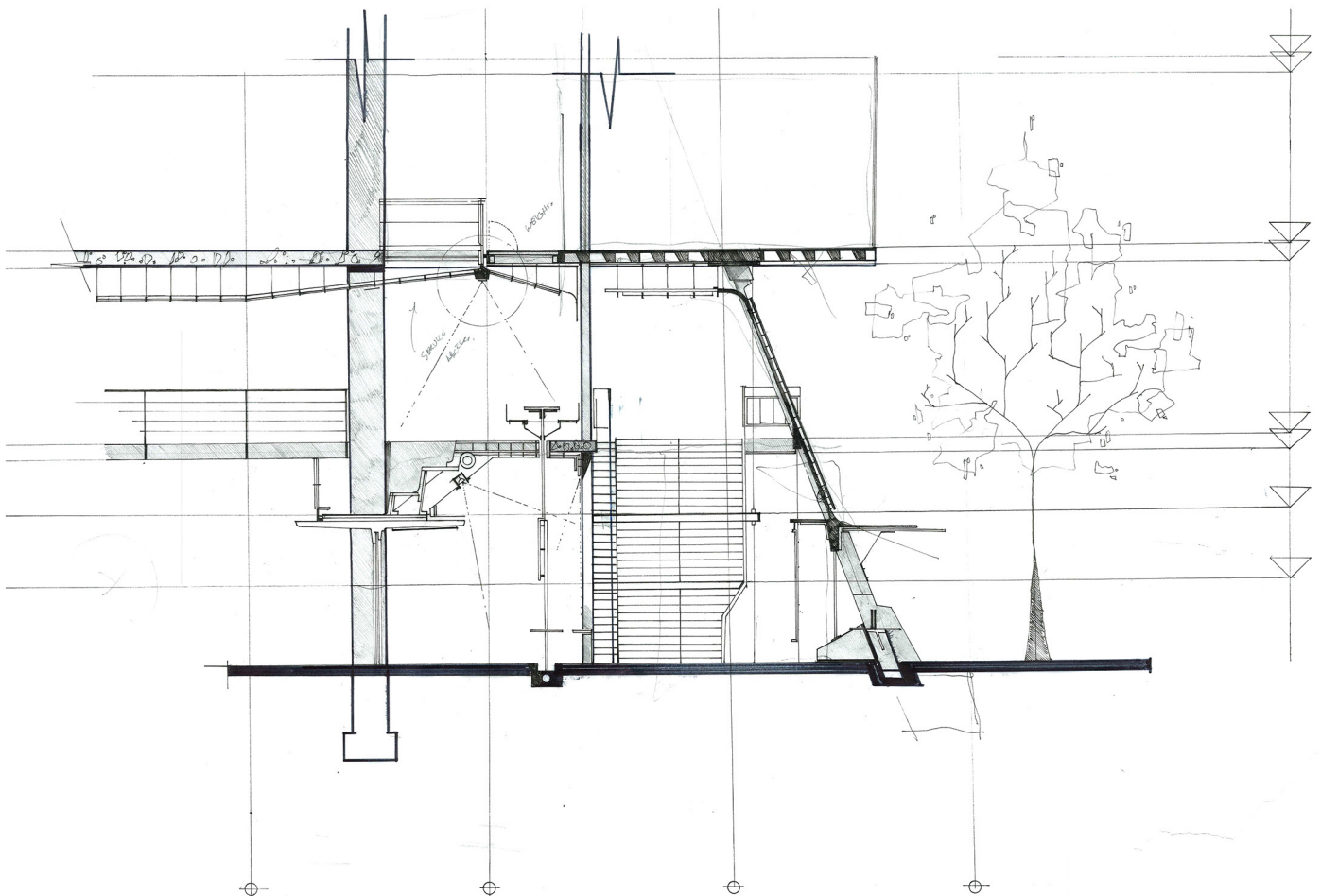

Fig. 6.7 Conceptual exploration of recalibration | public space / structure



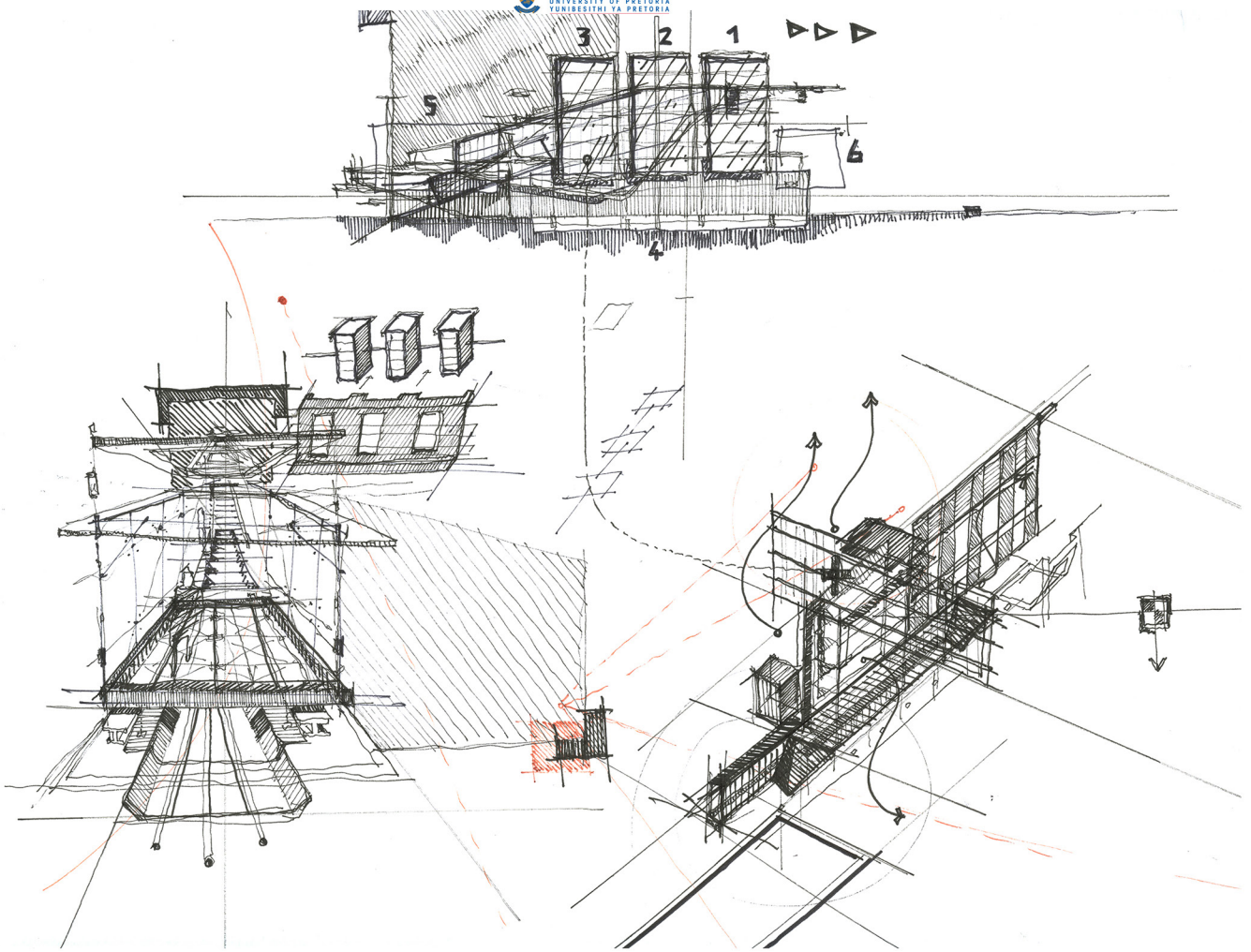
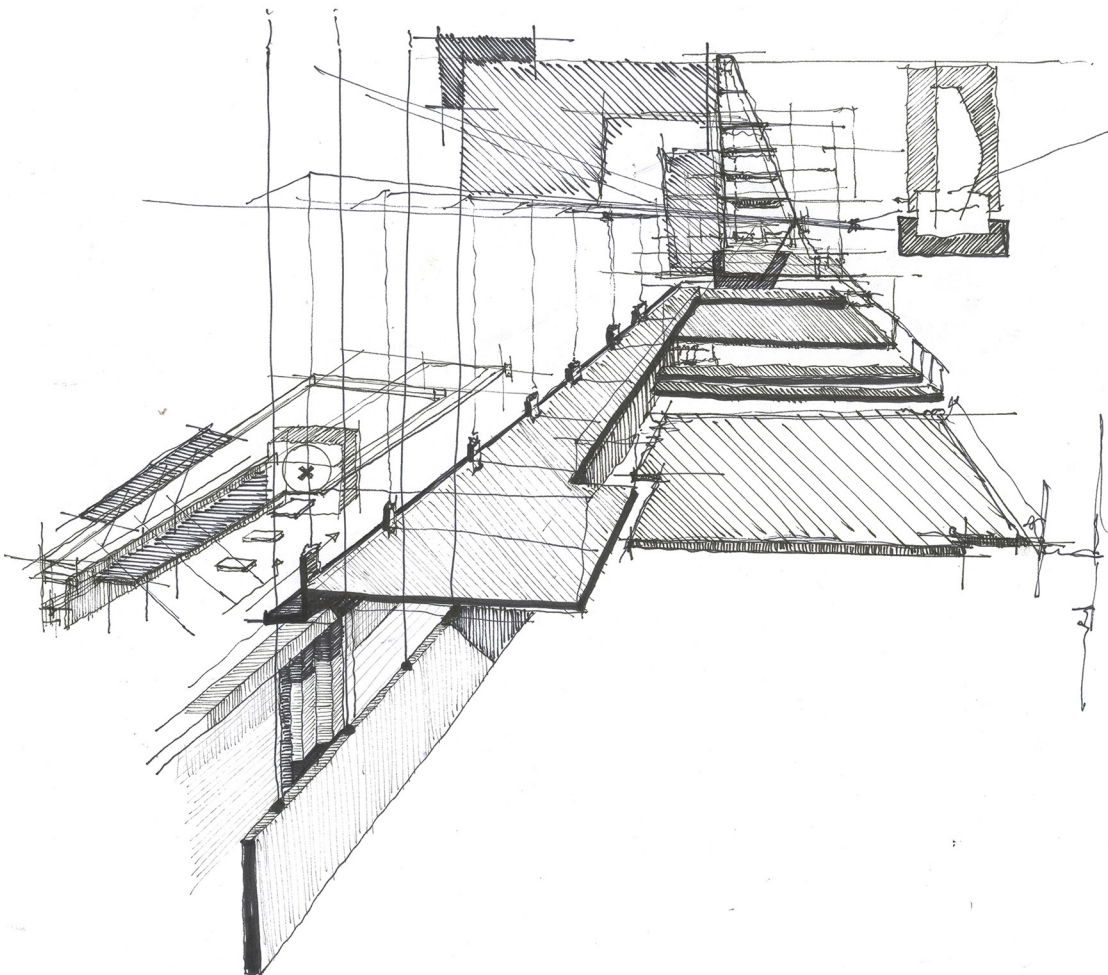

Fig. 6.8 Threshold and hierarchical progression of structure from Madiba Street entrance



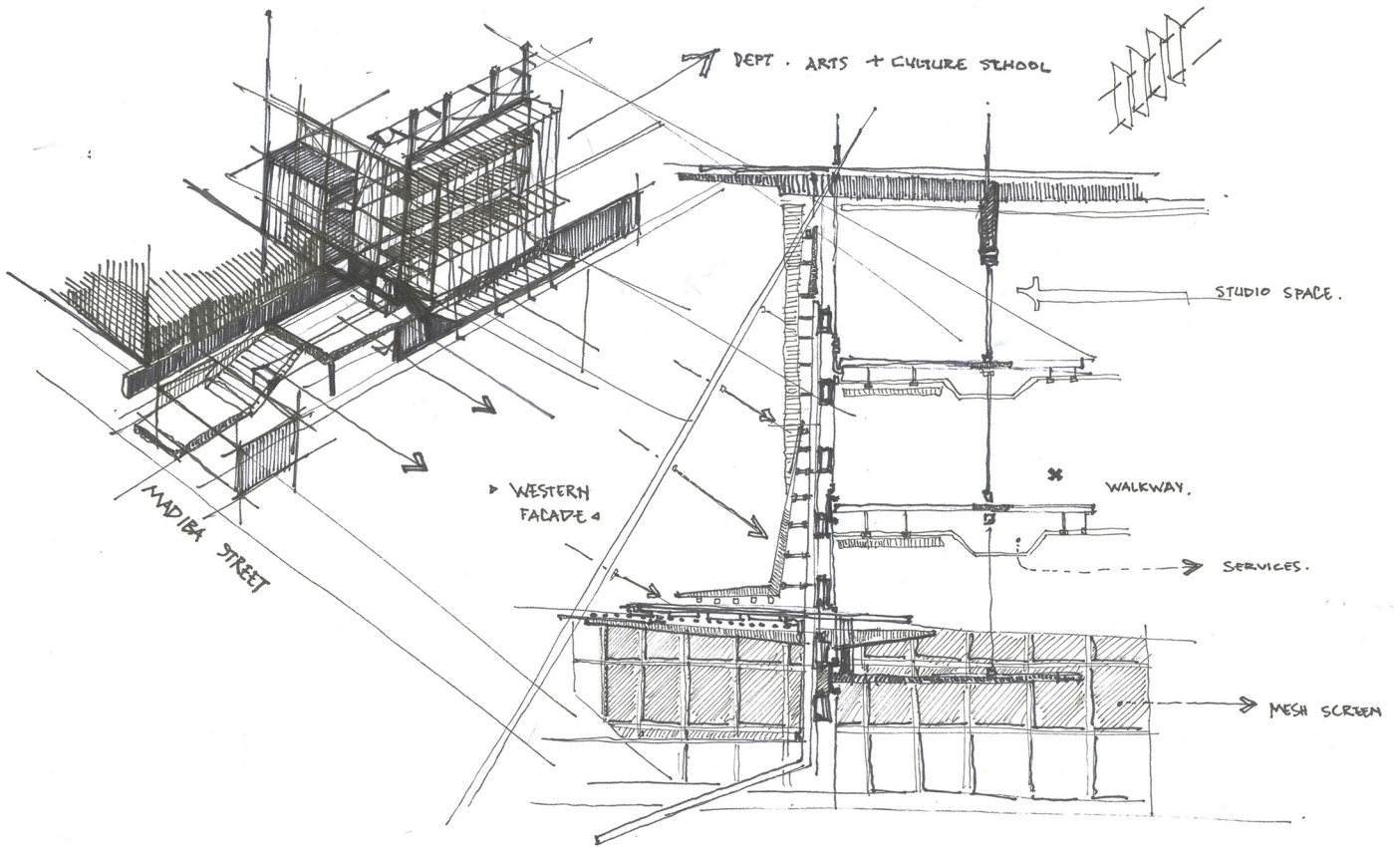
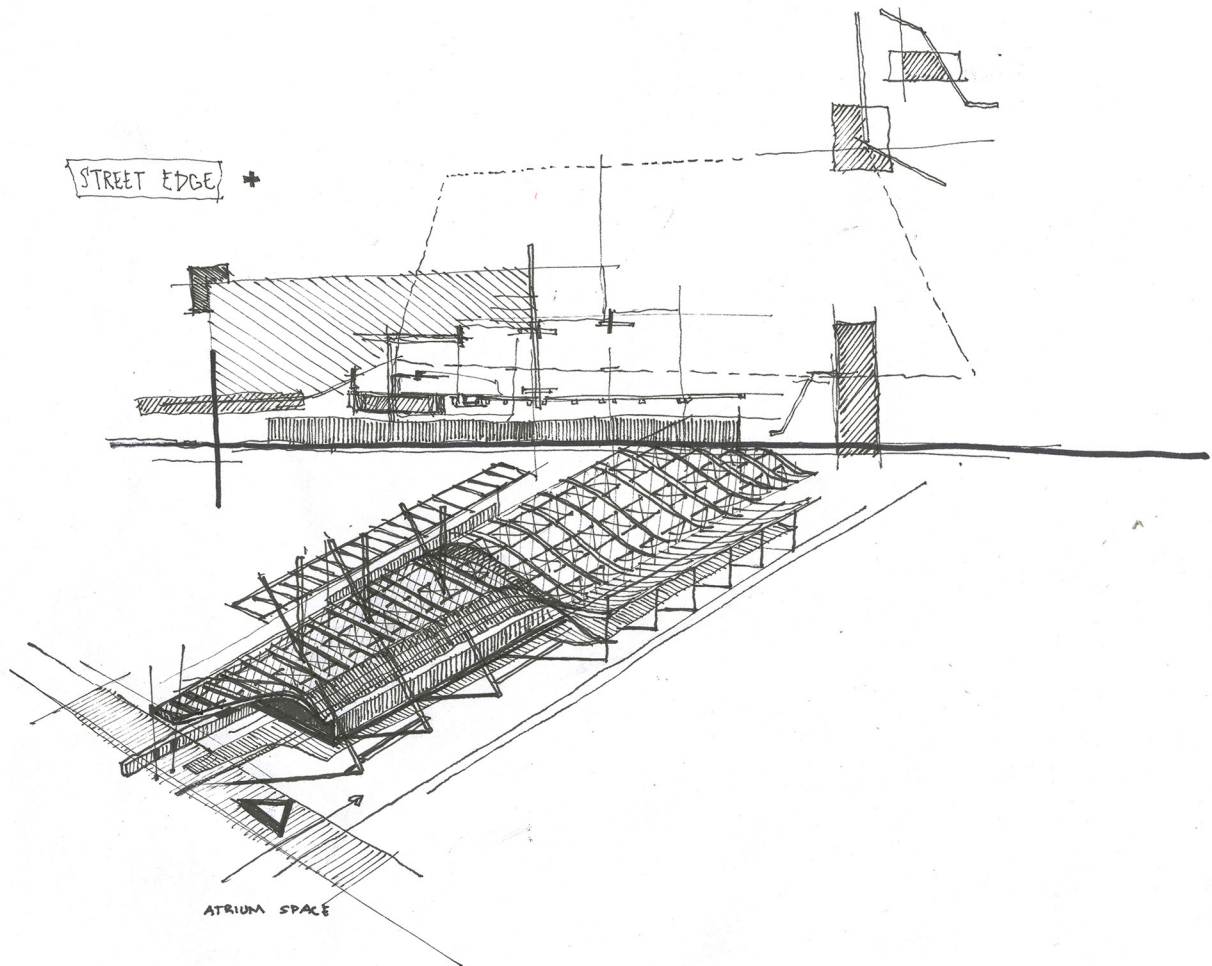

Fig. 6.9 Conceptual development of structure



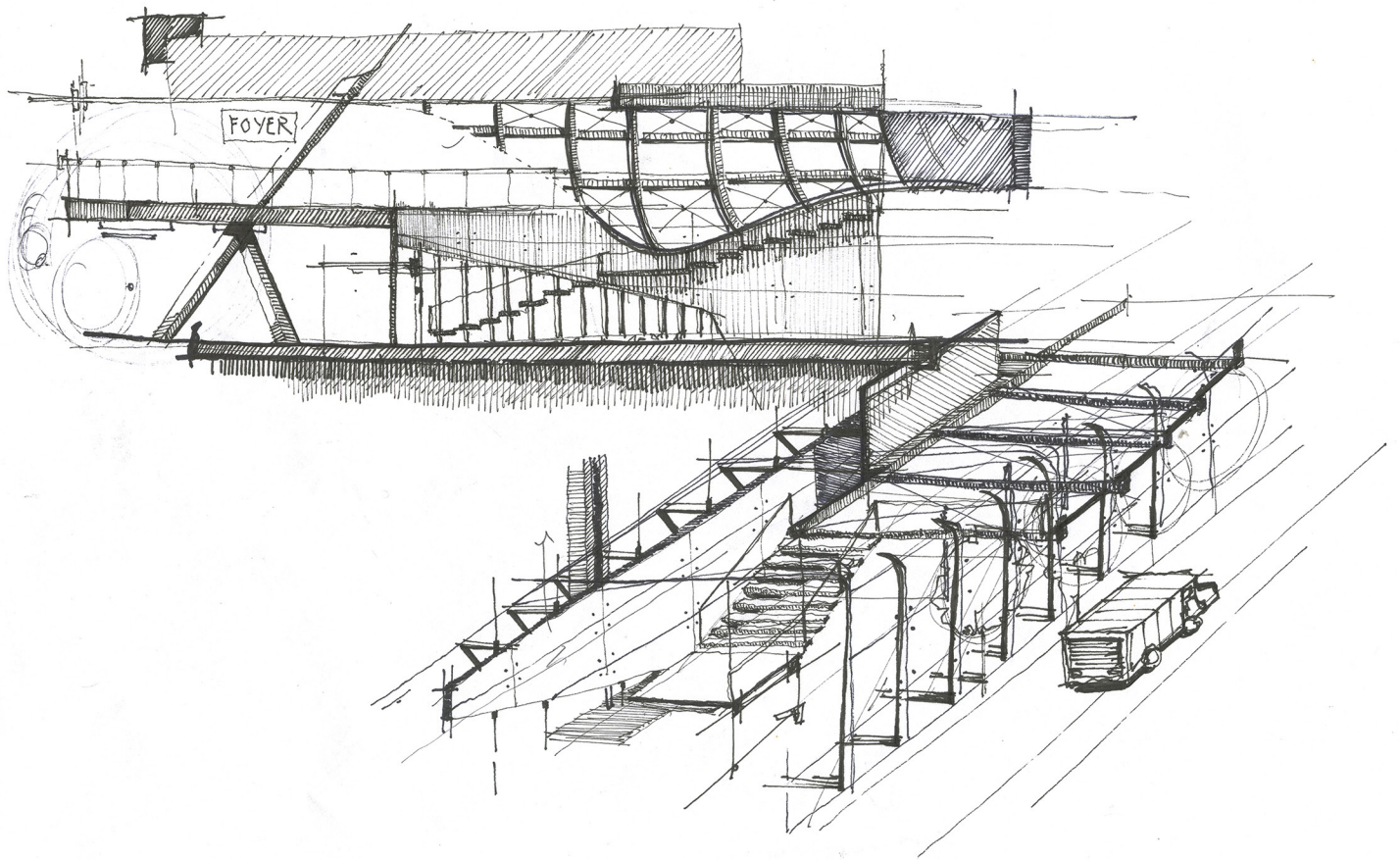
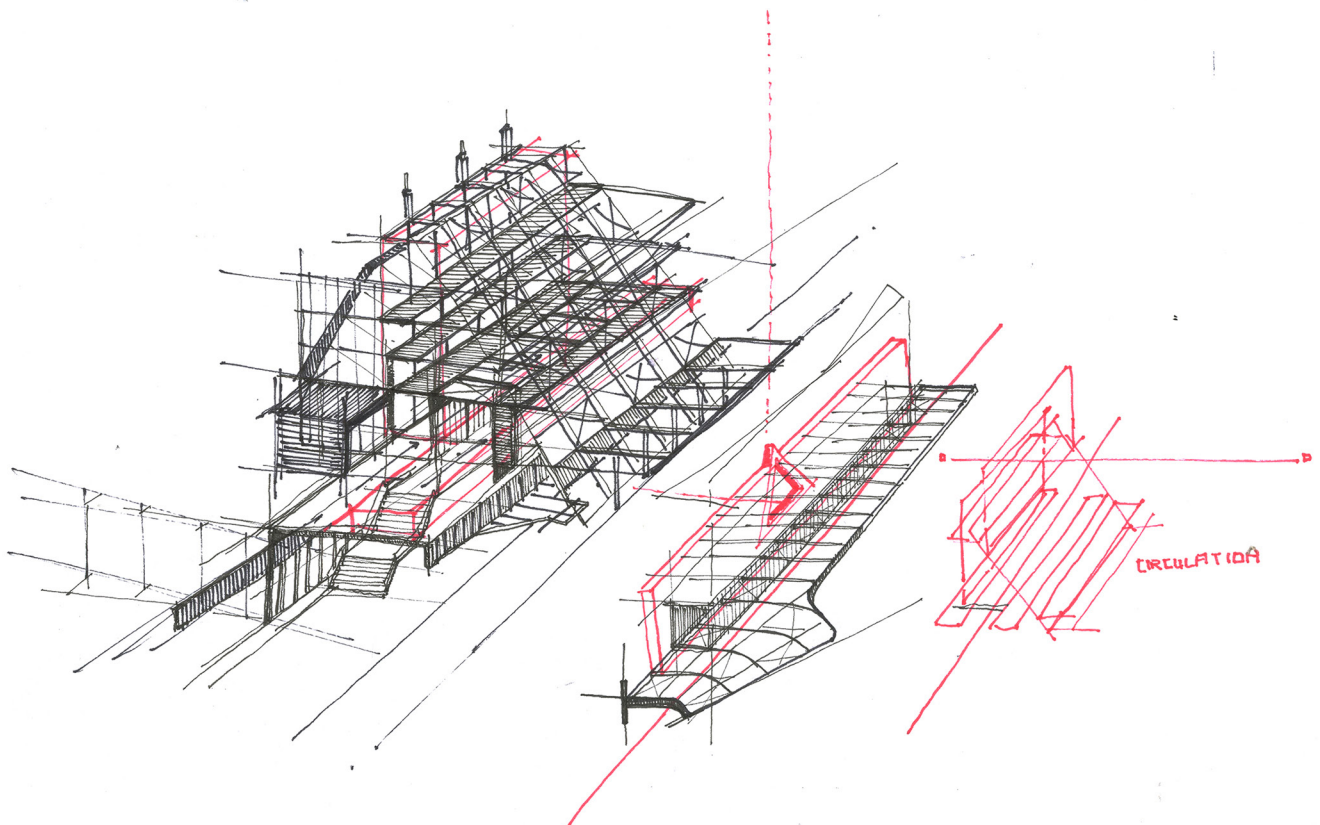

Fig. 6.10 Threshold and hierachical progression of structure from Madiba Street entrance



17 JANUARY 2012

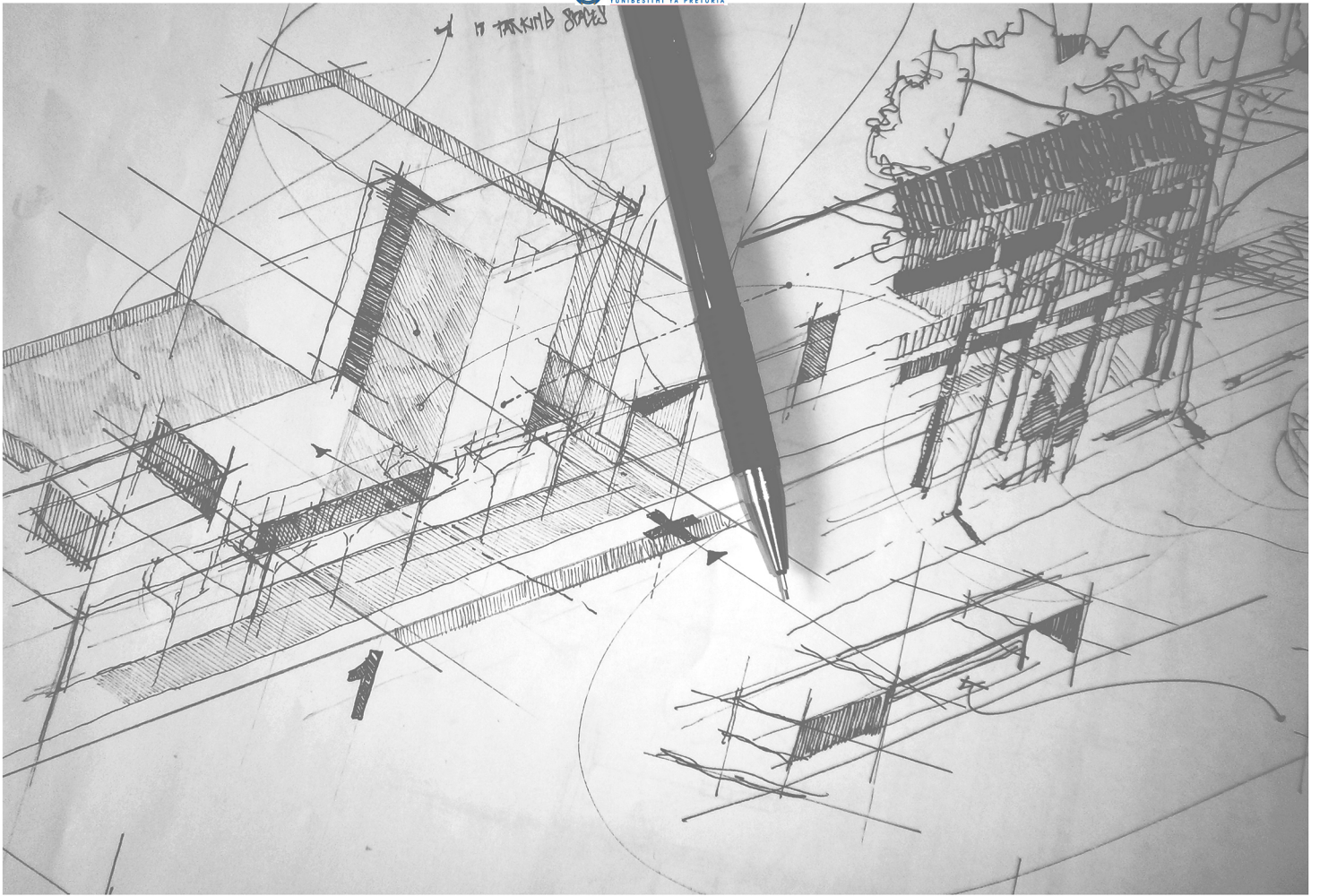
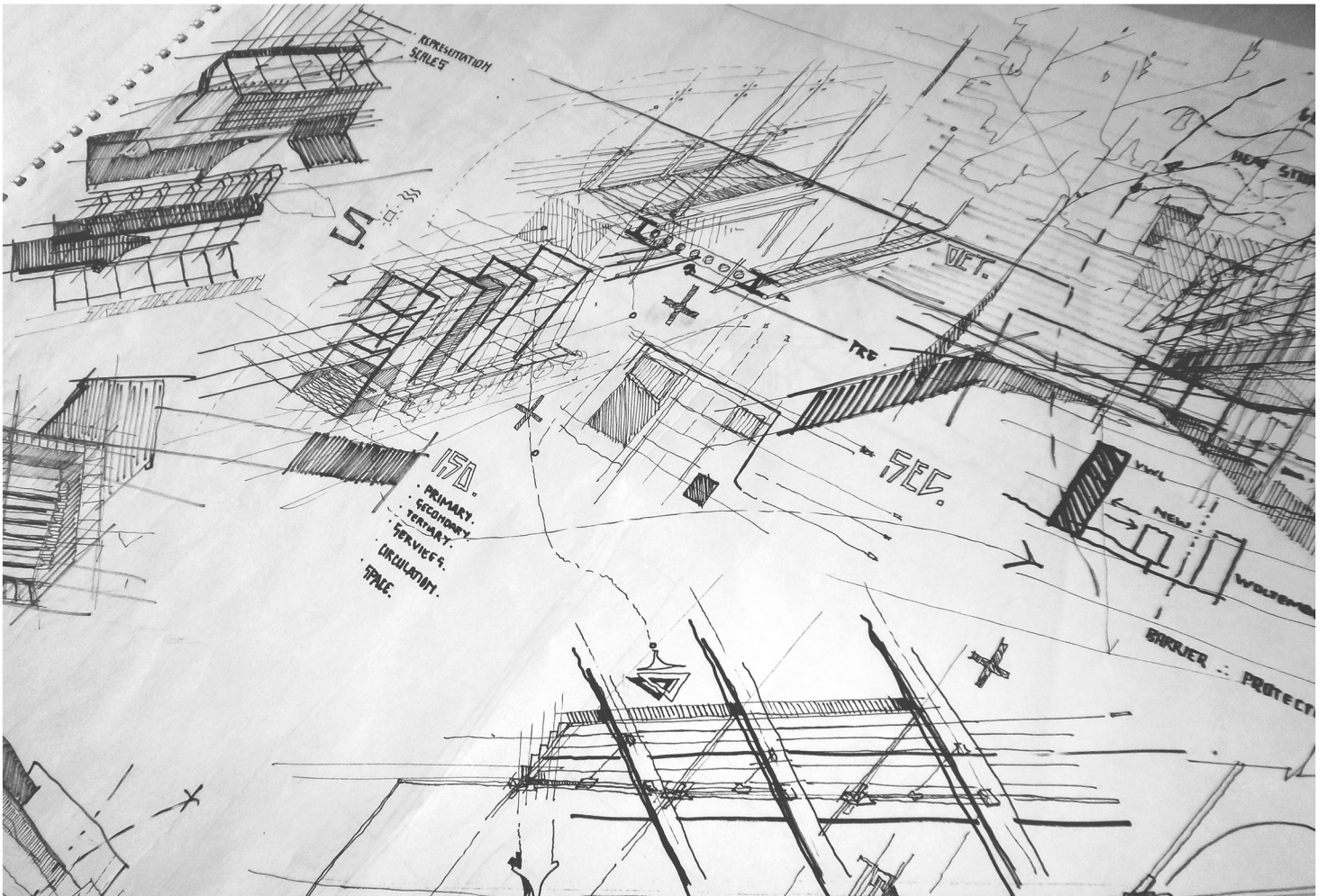

Fig. 6.11 Exploration of systems and access into site



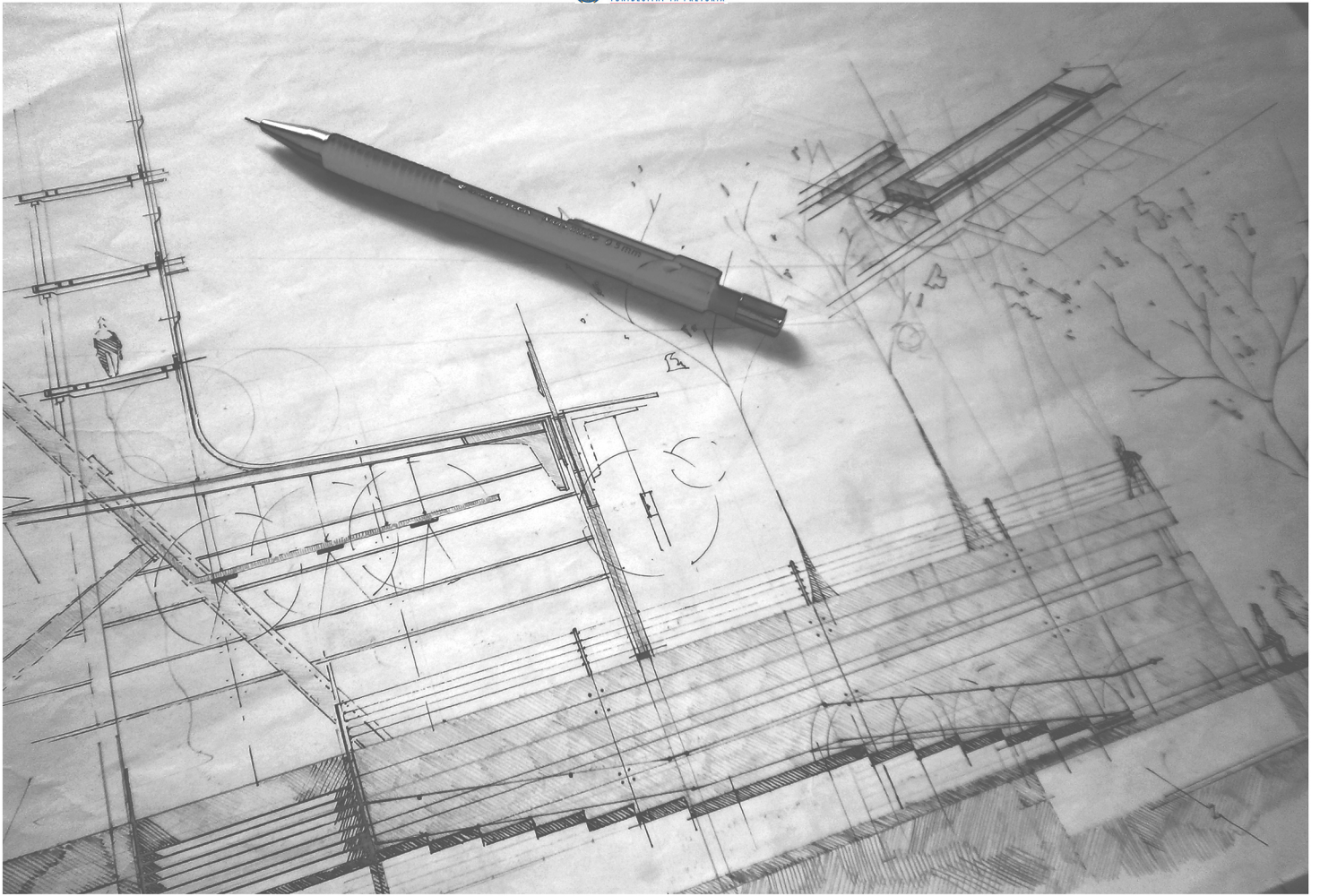
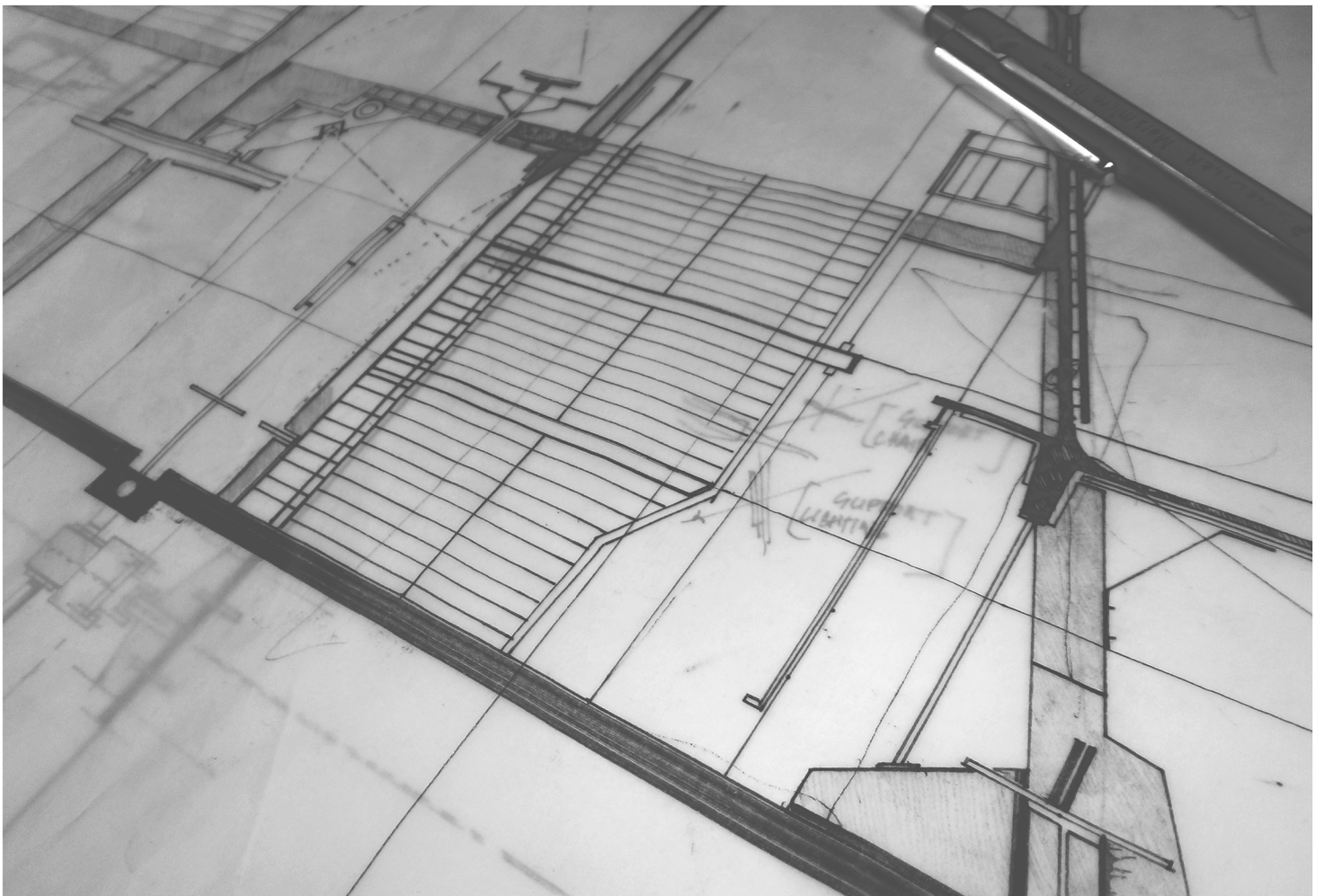

Fig. 6.12 Exploration of public recalibrated stairs as public seating | one element - multiple functions



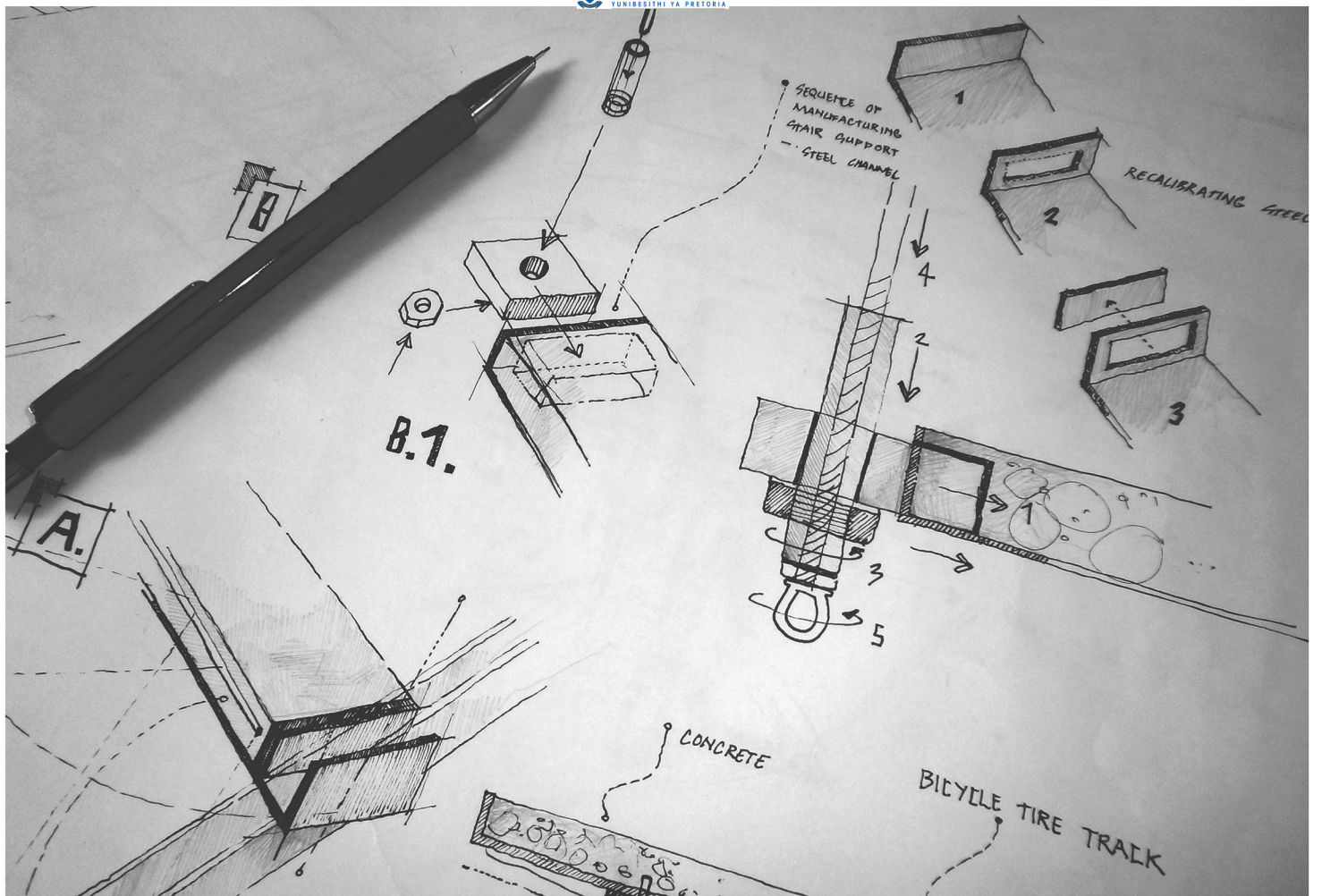
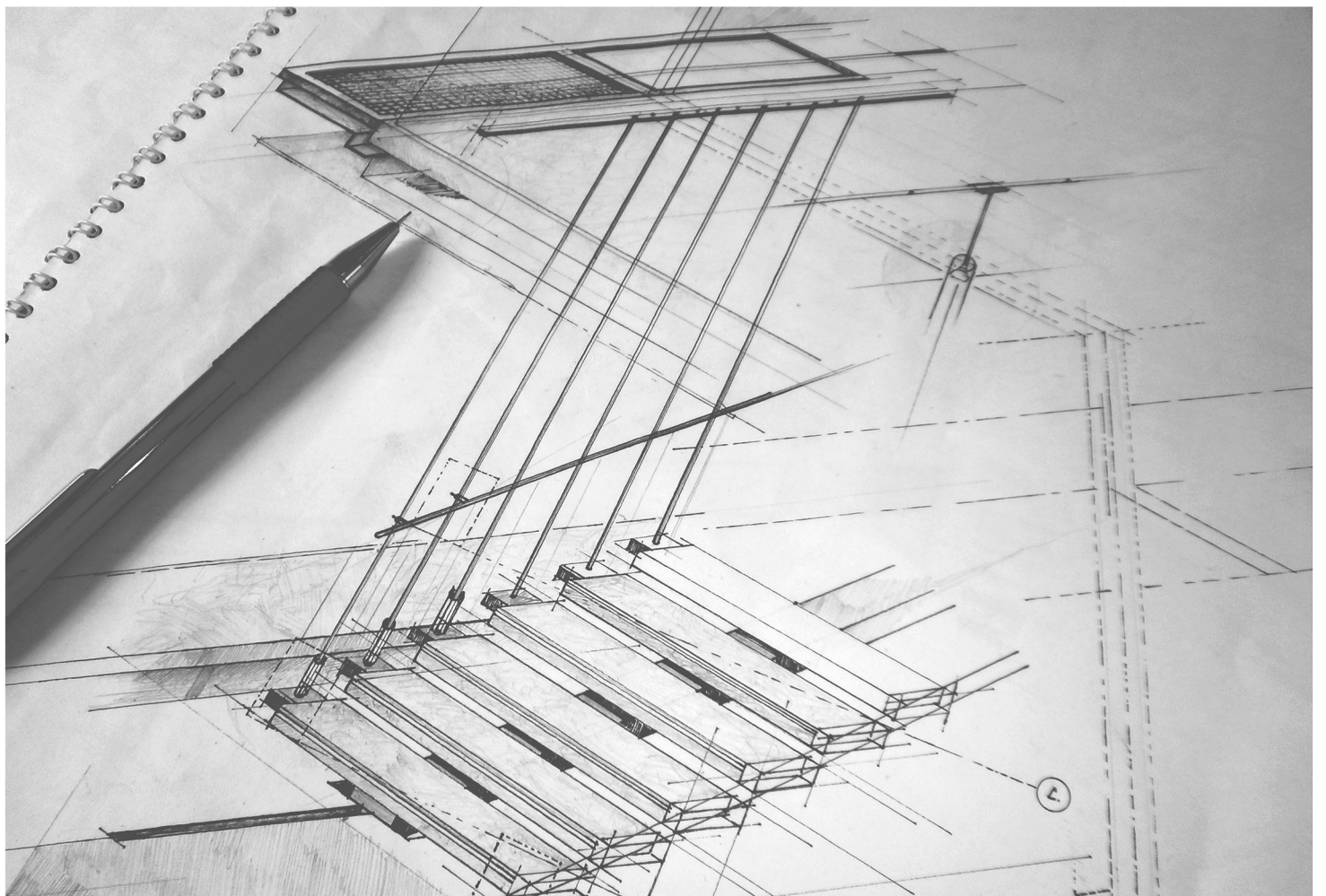

Fig. 6.13 Exploration of recalibrated stairs | detailing



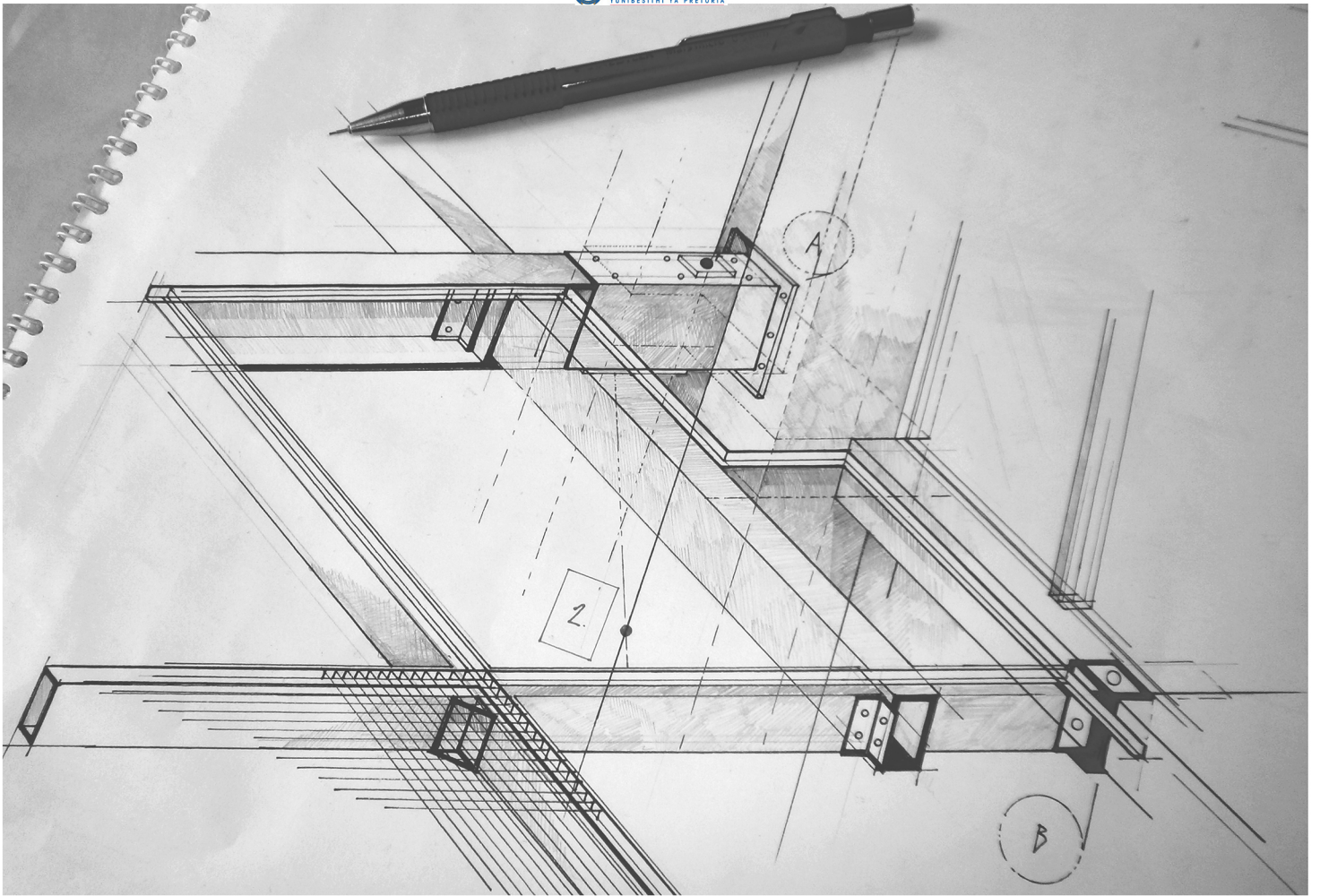

Fig. 6.14 Exploration of detailing | mentis grid walkway | beam to VWL column connection | beam to beam connection

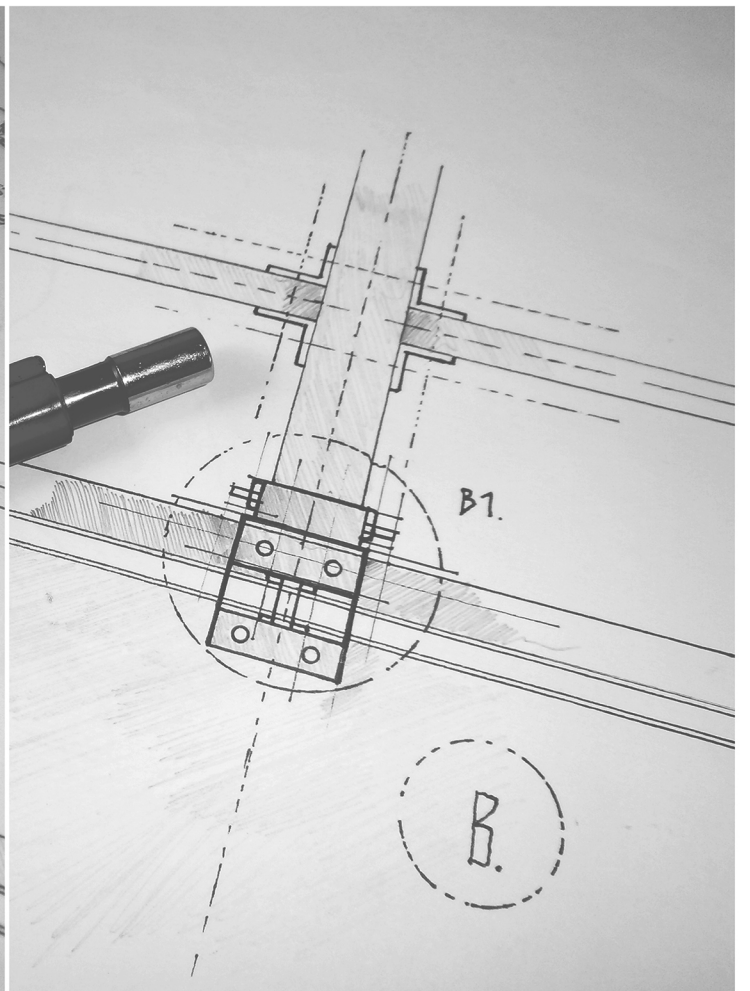
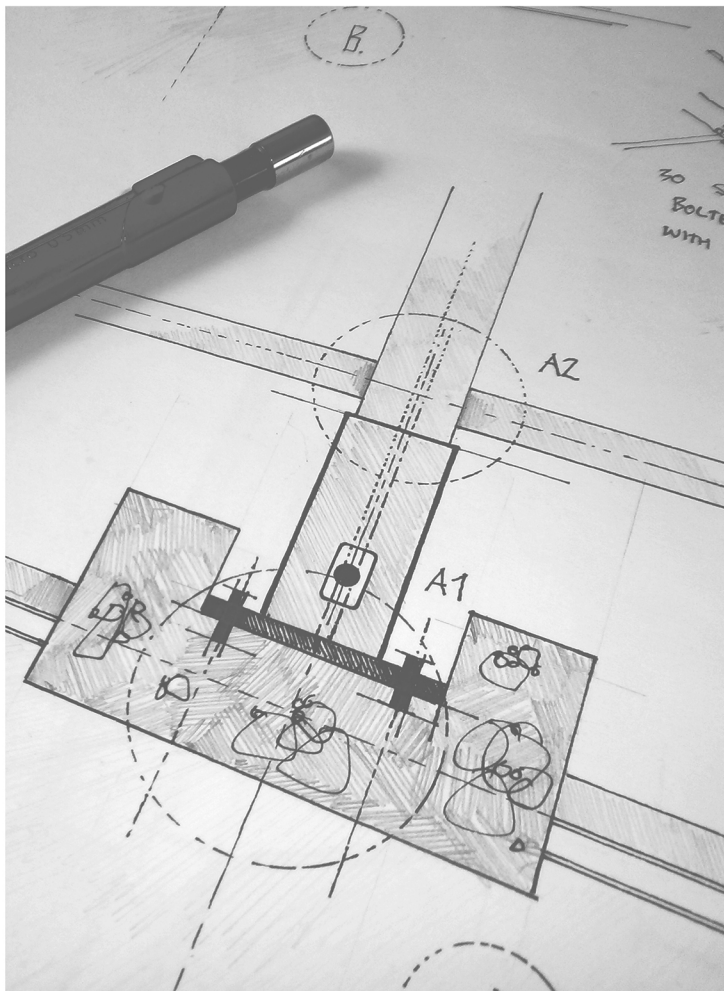
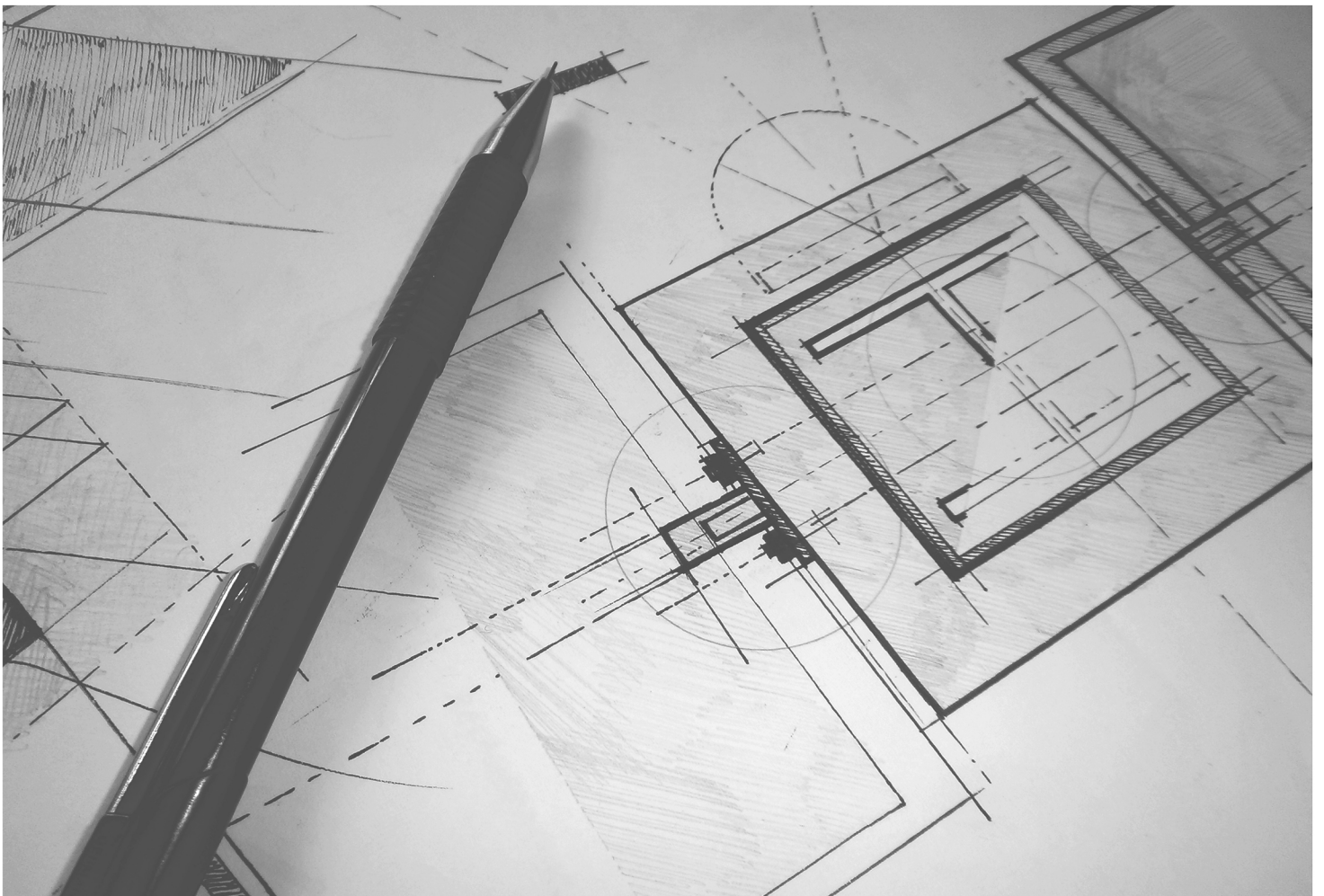



Fig. 6.15 Exploration of detailing | mentis grid walkway | column footing connection | public seating to column connection



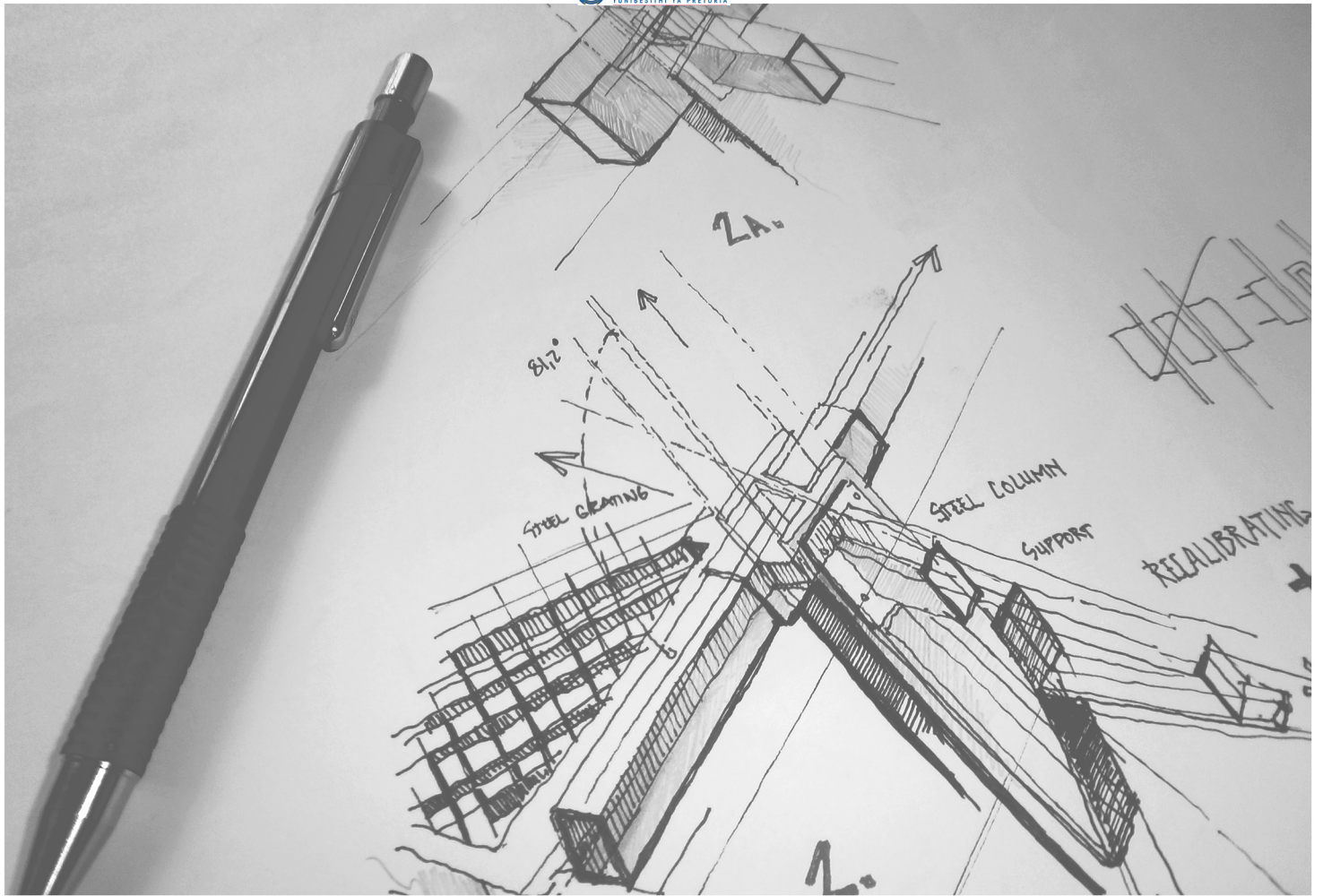
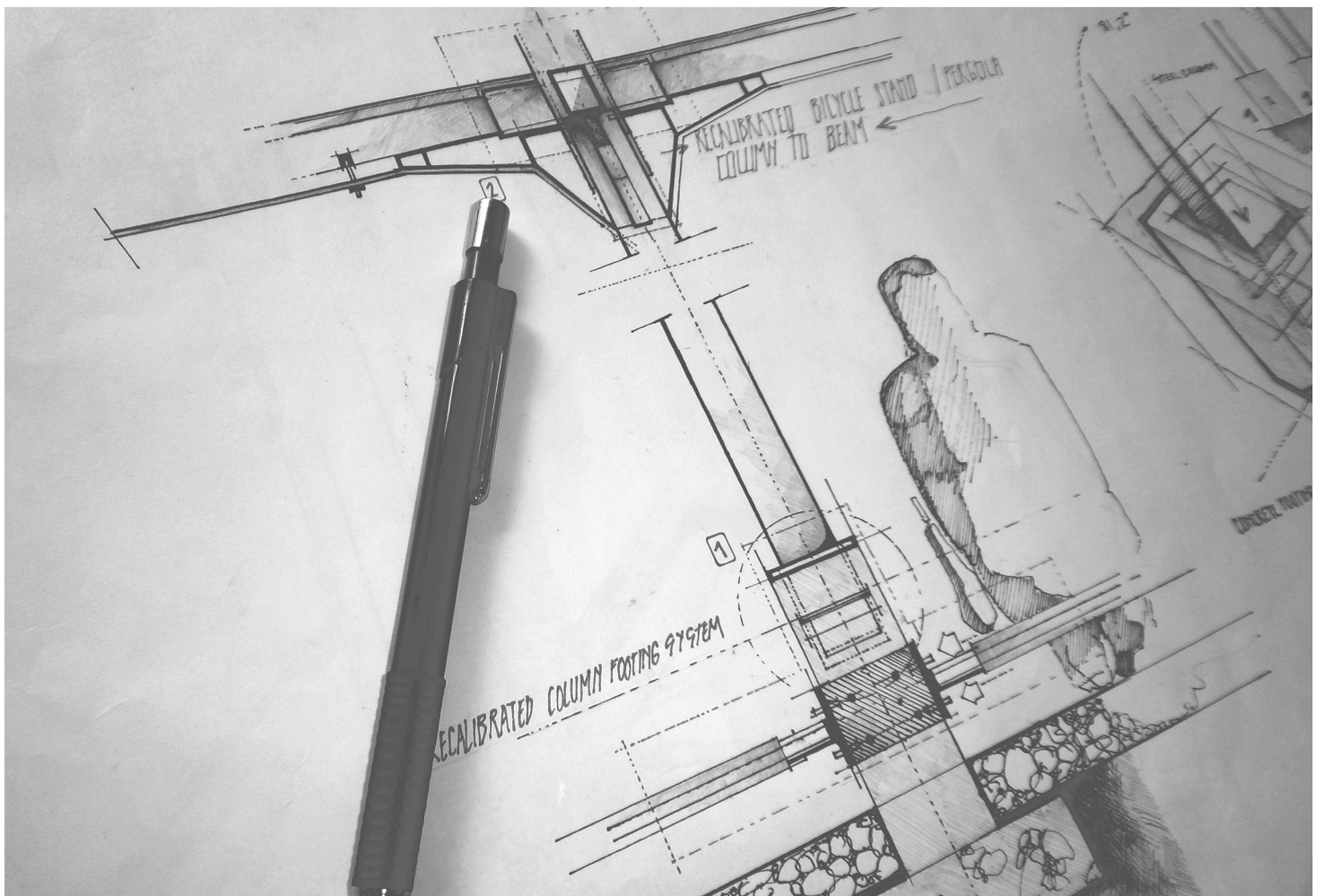

Fig. 6.16 Exploration of detailing | bicycle pergola construction | beam to beam connection



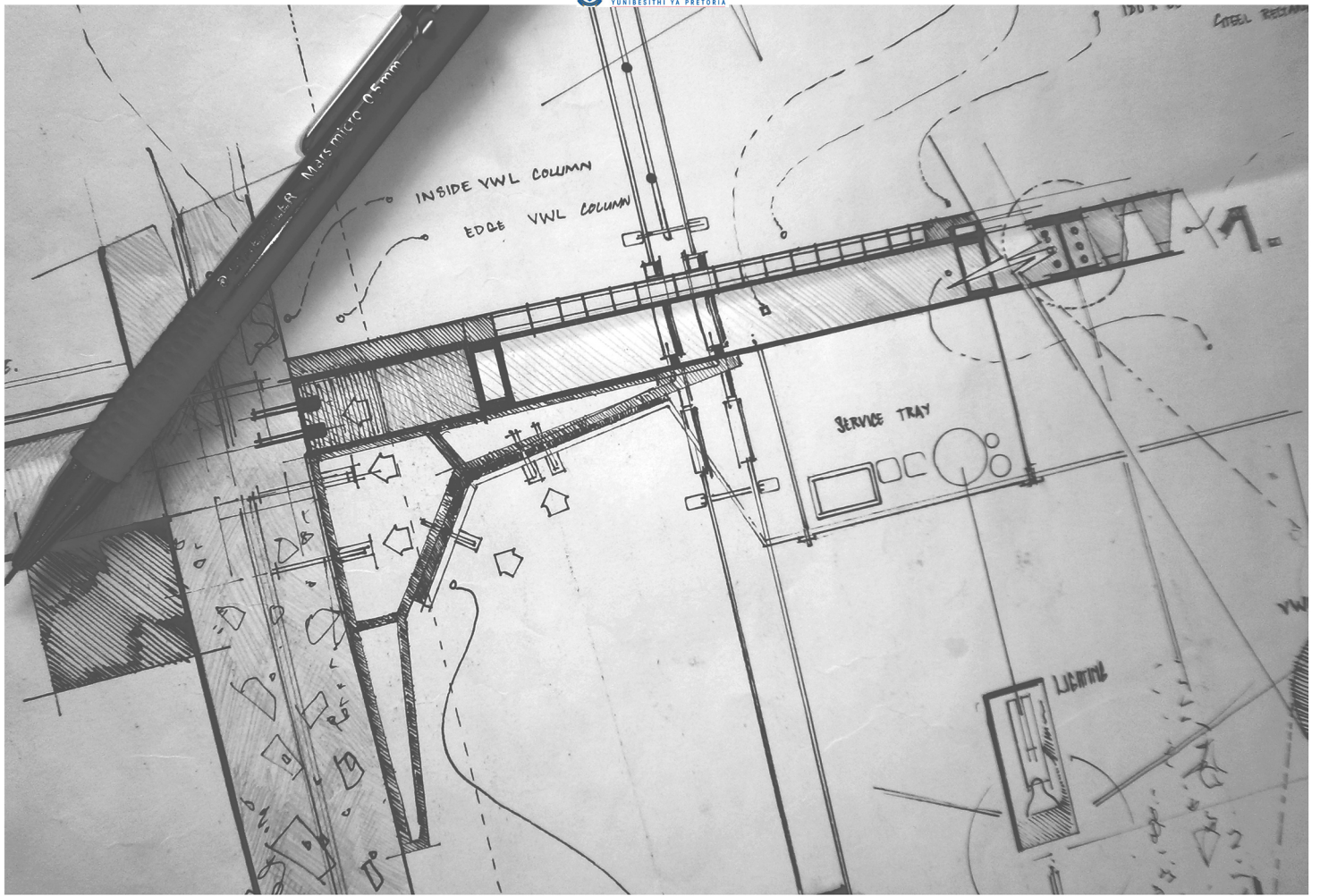
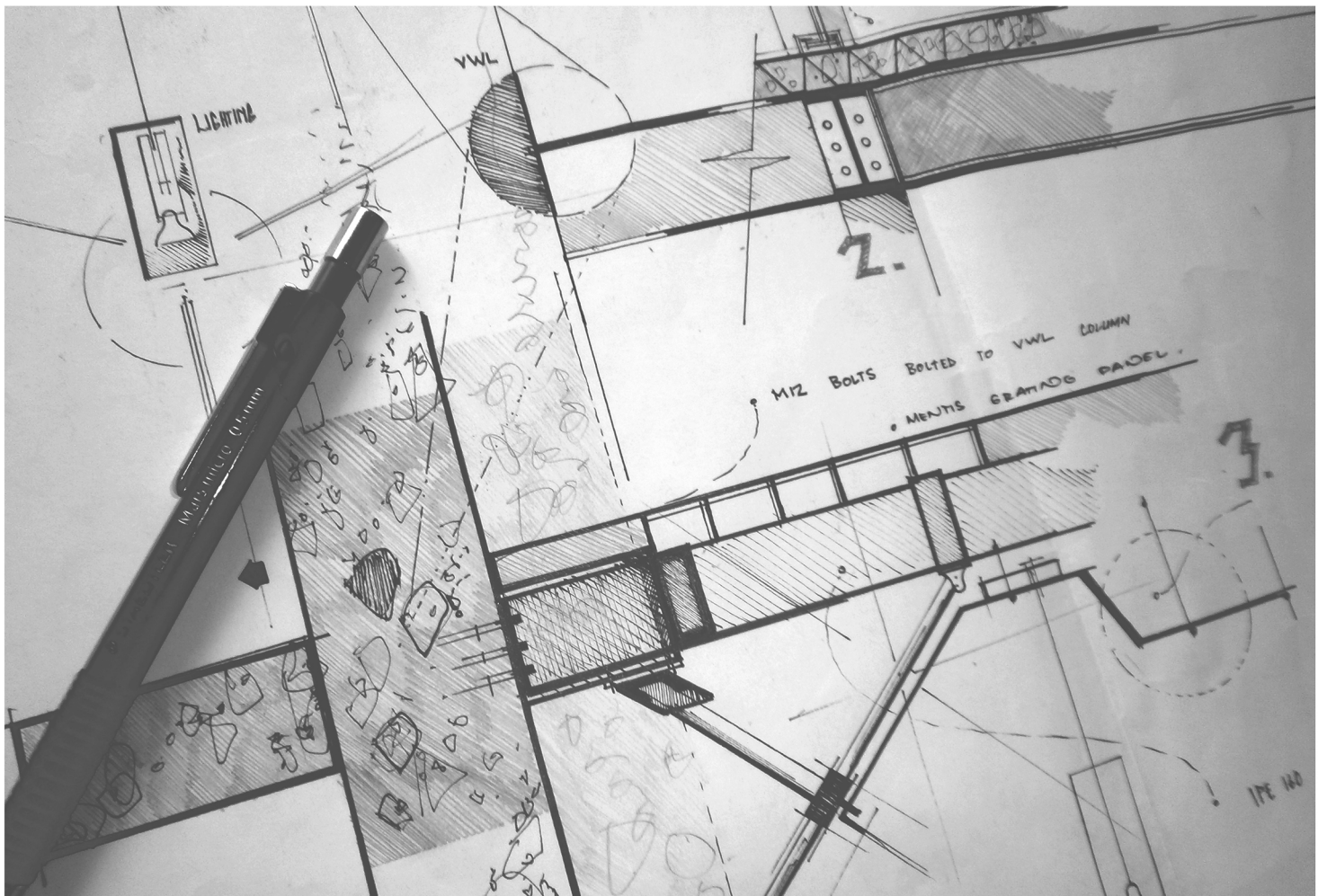

Fig. 6.17 Exploration of detailing | mentis grid detail | beam to VWL connection



TOP-DOWN MEETS BOTTOM-UP

- _ A new social contract
- _ A new condition

CLIENT

- A. DEPARTMENT OF ARTS AND CULTURE
- B. PRETORIA NEWS
- C. URBAN VANGUARD
- D. PUBLIC / ARTISTS/ CRITICAL MASS PRETORIA
- E. BEREA PARK INDEPENDENT SCHOOL

A. DEPARTMENT OF ARTS AND CULTURE

Two major clients are identified in terms of project feasibility and phasing. The first client is the Department of Arts and Culture. As the soon-to-be tenants of the VWL building, their presence initiates an art and educational precinct along the Ceremonial Route proposed for the City of Tshwane's Vision 2055. This programme would supplement the Department's 'arts' component of their profile. This would provide them with direct contact to their Public Art Programme. Furthermore, in keeping with their Mzansi Golden Economy Strategy, the precinct will initiate an interface between the Department and the public whilst providing one of five cultural precincts and information centres, which are being piloted in five major cities that are expected to create more than 2000 new work opportunities.

Programmes, Projects and Initiatives

The Public Art Programme, which will focus on 'beautification and story telling' (<http://www.gov.za/about-sa/arts-culture>, 2015) through art in communities and showcasing artistic talent, is one of three projects aimed at stimulating demand in the sector.

The programme is projected to create 5 000 work opportunities by 2014/15.

Mzansi Golden Economy Strategy

As part of the national target of creating five million jobs within the next 10 years, the DAC launched the Mzansi Golden Economy Strategy in 2011, which is expected to create more than 150 000 work opportunities between 2012 and 2017.

The strategy involves a number of arts and culture job creation programmes. These include the Public Art Programme, where youth will receive art classes, after which the department will employ them in their respective communities to beautify the environment through art. About 3 000 full time art facilitators will be deployed in schools throughout the country to facilitate the initiative. Along with the establishment of an Art Bank, this is expected to create 10 000 new work opportunities over the next three years.

B. PRETORIA NEWS

The second potential client is the Pretoria News that could supplement the identity of the Madiba Art Precinct as one of a precinct defined by the creative and cultural sector. The old printing works of the Pretoria News could be used for both public and institutional use as part of the an interactive programme that strengthens the public interface promoted by the Madiba Art Precinct. The intention with regards to along term vision is to utilise the old printing works as a school of journalism.

PROGRAMME

1. Practical implementation of programme

1. The Madiba Art Precinct would form part of the programmes, projects and initiatives framework of the DAC.
 2. The plinth and void condition of the VWL would be re-appropriated in recognition of a Smart Urbanism strategy.
 3. The act of urban recalibration would bolster the DAC's intention to provide economic opportunity for the arts and culture sector.
 4. To promote skill transfer among urban vanguards and the youth, and encourage interaction between Pretoria's artists and public.
-

2. Conceptual implementation of programme

1. The programme proposes mediation between the public and the government.
2. The programme proposes mediation between old and new ways of urban design strategies.
3. The Madiba Art Precinct could provide a catalytic response to the existing urban condition present in South African cities by proposing proto-urban conditions that recognise the importance of present and emergin vernaculars.

FIGURE REFERENCES

- Fig. 6.1 Morphosis, San Francisco Federal Building (morphopedia.com, 2015)
- Fig. 6.2 Abstract | Street edge condition and exploration | City at Eye Level (Author, 2015)
- Fig. 6.3 Abstract | Plinth exploration | Hybrid plinth condition (Author, 2015)
- Fig. 6.4 Exploration of site | Micro urban climate (Author, 2015)
- Fig. 6.5 Exploration of site | Micro urban climate (Author, 2015)
- Fig. 6.6 Threshold and progression of public space from Paul Kruger Street (Author, 2015)
- Fig. 6.7 Conceptual exploration of recalibration | public space / structure (Author, 2015)
- Fig. 6.8 Threshold and hierachical progression of structure from Madiba Street entrance (Author, 2015)
- Fig. 6.9 Conceptual development of structure (Author, 2015)
- Fig. 6.10 Threshold and hierachical progression of structure from Madiba Street entrance (Author, 2015)
- Fig. 6.11 Exploration of systems and access into site (Author, 2015)
- Fig. 6.12 Exploration of public recalibrated stairs as public seating | one element - multiple fucntions (Author, 2015)
- Fig. 6.13 Exploration of recalibrated stairs | detailing (Author, 2015)
- Fig. 6.14 Exploration of detailing | mentis grid walkway | beam to VWL column connection | beam to beam connection (Author, 2015)
- Fig. 6.15 Exploration of detailing | menti grid walkway | column footing connection | public seating to column connection (Author, 2015)
- Fig. 6.16 Exploration of detailing | bicycle pergola construction | beam to beam connection (Author, 2015)
- Fig. 6.17 Exploration of detailing | mentis grid detail | beam to VWL connection (Author, 2015)