

Active enhanced tunable high-Q on-chip E-band resonators in 130nm SiGe BiCMOS

Nishant Singh and Tinus Stander

Carl and Emily Fuchs Institute for Microelectronics
 Dept. EEC Engineering, University of Pretoria
 Pretoria, South Africa
 mr.nishant.singh@ieee.org

Abstract—A simulation study of a high-Q resonator in a commercial 130nm SiGe BiCMOS process for E-band frequencies is presented. The resonator is a planar quarter-wave microstrip resonator that uses a HBT based negative resistance circuit to counter losses and enhance the unloaded Q-factor. Using 3D EM (FEM) and circuit co-simulation, enhanced unloaded Q-factors of up to 892 are shown at a frequency of 83.5 GHz compared to the unenhanced unloaded Q-factor of 7. The negative resistance circuit sufficiently compensates for low Q-factors of the planar resonator and the varactor. The resonator is also shown to be continuously tunable in frequency from 82 to 84 GHz, and in unloaded Q-factor from 7 to 892, whilst maintaining unconditional stability in all tuning states.

Keywords— millimeter wave integrated circuits; BiCMOS integrated circuits; Q measurement; heterojunction bipolar transistors; resonators

I. INTRODUCTION

The millimeter-wave spectrum offers significant unused bandwidth for short and medium range wireless communication systems such as next generation cellular networks [1]. Two channels in the E-Band have been specially designated for this purpose within the frequency ranges of 71-76 GHz and 81-86 GHz [2].

Silicon based monolithic solutions have the potential to make this technology cheaper and smaller leading to wider adoption and utilization of the band. A significant barrier to fully-integrated single-chip solutions is the high loss associated with on-chip transmission lines on the back-end-of-line (BEOL) metallization layers [3].

Quarter or half wavelength transmission lines are used to make resonators which are a basic building block of filters and oscillators [4]. Quarter-wave resonators made using lossy on-chip transmission lines exhibit low unloaded Q-factors (Q_0) between 3 and 15 across various topologies such as microstrip and CPW [5]. Coupled resonator bandpass filters made with low-Q resonators yield high insertion loss with poor selectivity [6].

Negative resistance circuits have been shown to counter losses in resonators and improve Q_0 [7]. This concept has been

shown to be feasible at 60 GHz on a GaAs MMIC [8], but has never been demonstrated for the E-band using a commercial SiGe BiCMOS process. Furthermore, combining active Q-enhancement with resonant frequency tuning will allow for the synthesis of low loss frequency agile filters, though this dual tuning ability has not been demonstrated yet.

This work contributes to the state-of-the-art by demonstrating a high-Q frequency tunable resonator using an active negative resistance circuit in IHP SG13G2 130nm SiGe BiCMOS technology with f_i/f_{max} of 300/500 GHz [9]. The simulations are carried out using Keysight ADS software supplemented with the foundry PDK. FEM is used for 3D-EM and circuit co-simulations.

II. NEGATIVE RESISTANCE CIRCUIT

The negative resistance is generated at the base of the transistor Q_1 in a common collector-configuration biased with a current source and connected to a feedback network made using capacitor C_1 and varactor C_2 [10]. A simplified circuit diagram neglecting biasing details is shown in Fig. 1.

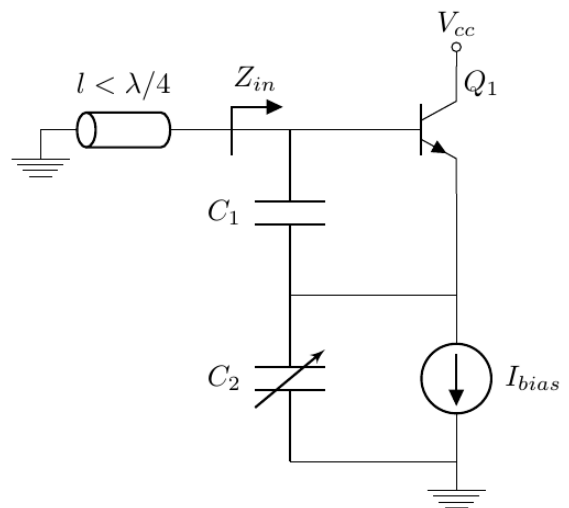

Fig. 1. Transmission line resonator with negative resistance circuit

The input impedance is expressed as [11]:

$$Z_{in} = \frac{-g_m}{\omega^2 C_1 C_2} + \frac{C_1 + C_2}{j\omega C_1 C_2} \quad (1)$$

The real term is the negative resistance that counters resonator losses when the resonator is connected at Z_{in} while the imaginary term signifies capacitive loading. The capacitive loading reduces the resonant frequency of the resultant circuit thus reducing the length of the transmission line resonator required for a given frequency. This is desirable as size reduction saves real-estate on the die, thereby reducing manufacturing costs.

The input impedance of the circuit is simulated as shown in Fig. 2 for values of C_1 as 14 fF and a bias current of 681 μ A. C_2 is a varactor with four columns with each column having a width of 3.74 μ m and a length of 0.3 μ m biased at 0.1 V. Q_1 is a HBT with an emitter width of 0.07 μ m and an emitter length of 0.9 μ m, with eight emitters on the same collector increasing the maximum I_C to 786 μ A. The f_t/f_{max} of this transistor at this bias current is 170/310 GHz.

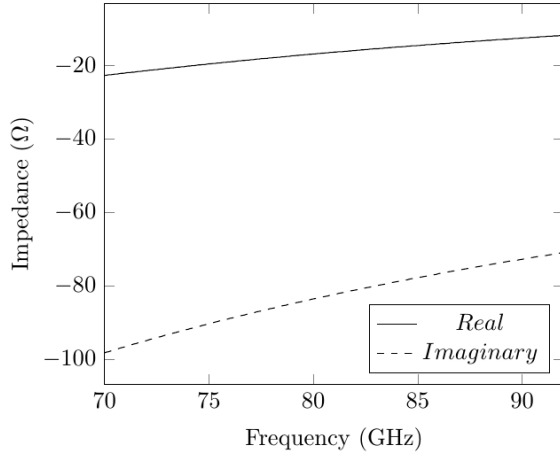

Fig. 2. Input impedance of active enhancement circuit

III. ACTIVE ENHANCED RESONATOR

Based on published literature [5], a microstrip transmission line was used to make a quarter-wave resonator with weak symmetrical input and output coupling. The thick top metal layer (TM2) was used for the signal while the lowest metallization layer (M1) for ground as shown in Fig. 3. One end of the resonator was shorted using a 43 μ m by 2 μ m via array from TM2 to M1. This layout was simulated using FEM in ADS which accounts for 3D-EM effects of the via array.

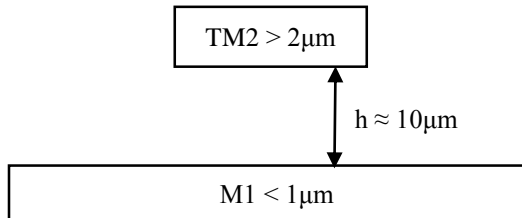

Fig. 3. Microstrip using typical 130nm SiGe BiCMOS BEOL

Due to the capacitive loading by the negative resistance circuit, the passive resonator length was shortened to approximately 65° at a center frequency of 83.5 GHz. This resulted in a resonator length of 350 μ m while the resonator width was chosen to be 43 μ m. The negative resistance circuit was connected to the open circuit end of the planar resonator as shown in Fig. 4. This active and passive arrangement was simulated using ADS EM and circuit co-simulation.

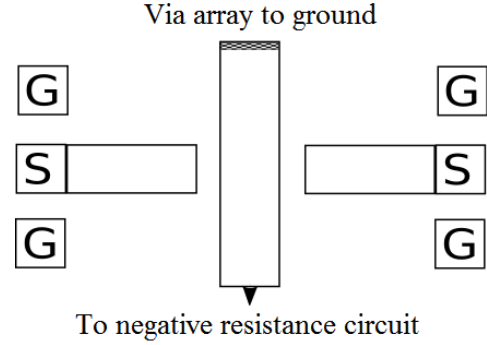

Fig. 4. Microstrip resonator with enhancement circuit

Q_0 was extracted from two port s-parameters using the following formulations [12]:

$$Q_L = \frac{f_c}{BW_{3dB}} \quad (2)$$

$$Q_0 = \frac{Q_L}{1 - |S_{21}|_{f=f_c}} \quad (3)$$

Q_0 was increased from 7 to 892 using the negative resistance circuit as shown in Fig. 5. The active resonator is assessed to be unconditionally stable using Rollett's stability criterion ($K > 1$) as shown in Fig. 6 [13]. The resonant frequency can be tuned by changing the varactor voltage as shown in Fig. 7 and Table I. Q_0 can be tuned by varying the bias current while keeping the capacitors constant as shown in Fig. 8 and Table II. This is because Z_{in} is dependent on g_m in (1) while g_m is dependent on I_C as follows:

$$g_m = \frac{I_C}{V_T} \quad (4)$$

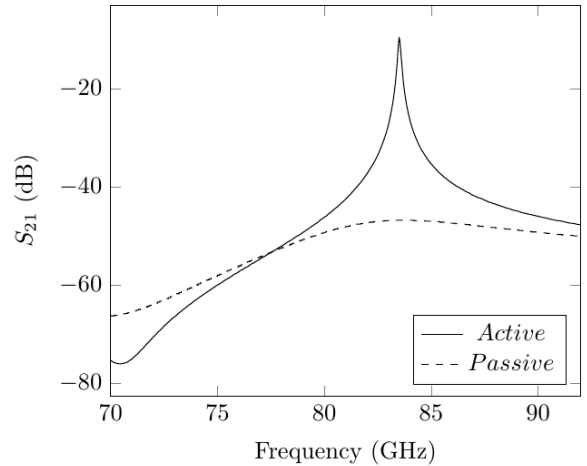

Fig. 5. Comparison of transmission response with and without enhancement

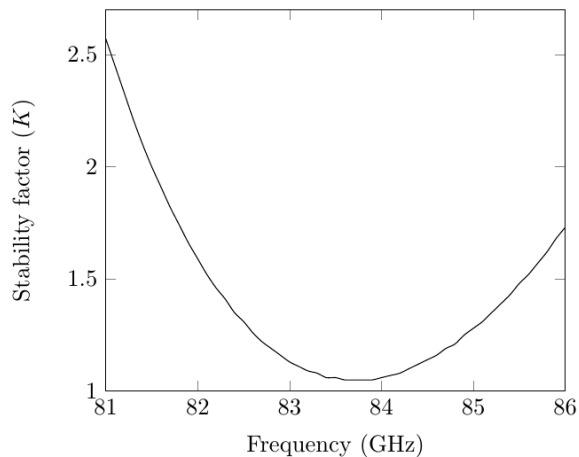

Fig. 6. Stability factor (K) of active resonator

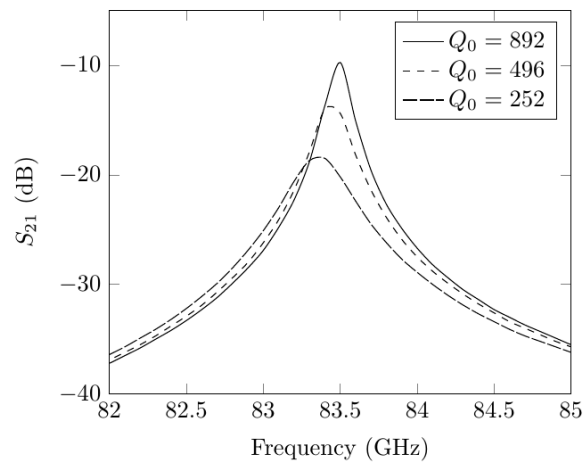

Fig. 8. Tuning of Q_0

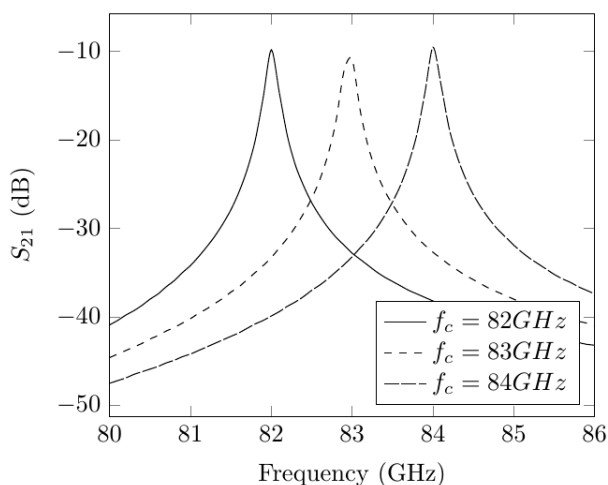

Fig. 7. Tuning of resonant frequency

TABLE I. FREQUENCY TUNING PARAMETERS

f_c	Varactor voltage	I_c
82 GHz	-1.2 V	686 μ A
83 GHz	-0.3 V	650 μ A
84 GHz	0.9 V	756 μ A

TABLE II. Q_0 TUNING PARAMETERS

Q_0	I_c
252	644 μ A
496	669 μ A
892	681 μ A

IV. CONCLUSION

An active Q-enhanced fully-tunable on-chip microstrip resonator for the E-band is presented using a commercial 130nm SiGe BiCMOS process. Simulations show that Q_0 of up to 892 is possible for a center frequency of 83.5 GHz. The negative resistance circuit is able to compensate for low Q_0 of the resonator as well as the varactor used in the feedback network. The resulting active resonator is unconditionally stable. The center frequency is tunable from 82 to 84 GHz while Q_0 is tunable from 7 to 891. It is expected that this resonator can be used to make frequency agile lossless bandpass filters resulting in full monolithic integration of millimeter-wave systems on silicon.

ACKNOWLEDGMENT

This work is supported by the National Research Foundation of South Africa (NRF) under Grants 92526 and 93921, as well as the UNESCO Participation Programme.

REFERENCES

- [1] S. Rangan, T. S. Rappaport, and E. Erkip, "Millimeter-Wave Cellular Wireless Networks: Potentials and Challenges," *Proc. IEEE*, vol. 102, no. 3, pp. 366–385, Mar. 2014.
- [2] O. Katz, R. Ben-Yishay, R. Carmon, B. Sheinman, F. Szenher, D. Papae, and D. Elad, "A fully integrated SiGe E-BAND transceiver chipset for broadband point-to-point communication," in *2012 IEEE Radio and Wireless Symposium*, 2012, no. 1, pp. 431–434.
- [3] C. H. Doan, S. Emami, A. M. Niknejad, and R. W. Brodersen, "Millimeter-wave CMOS design," *IEEE J. Solid-State Circuits*, vol. 40, no. 1, pp. 144–155, Jan. 2005.
- [4] R. Levy, R. Snyder, and G. Matthaei, "Design of microwave filters," *IEEE Trans. Microw. Theory Tech.*, vol. 50, no. 3, pp. 783–793, Mar. 2002.
- [5] T. Stander, "A comparison of basic 94 GHz planar transmission line resonators in commercial BiCMOS back-end-of-line processes," in *2014 International Conference on Actual Problems of Electron Devices Engineering (APEDE)*, 2014, pp. 185–192.
- [6] R. Evans, "Design of integrated millimetre wave microstrip interdigital bandpass filters on CMOS technology," in *2007 European Microwave Conference*, 2007, no. October, pp. 680–683.

- [7] U. Karacaoglu and I. D. Robertson, "High selectivity varactor-tuned MMIC bandpass filter using lossless active resonators," in *Proceedings of 1994 IEEE Microwave and Millimeter-Wave Monolithic Circuits Symposium*, 1994, pp. 237–240.
- [8] M. Ito, K. Maruhashi, S. Kishimoto, and K. Ohata, "60-GHz-Band Coplanar MMIC Active Filters," *IEEE Trans. Microw. Theory Tech.*, vol. 52, no. 3, pp. 743–750, Mar. 2004.
- [9] H. Rucker and B. Heinemann, "SiGe BiCMOS technology for mm-wave systems," in *2012 International SoC Design Conference (ISOCC)*, 2012, pp. 266–268.
- [10] V. Jain, B. Javid, and P. Heydari, "A BiCMOS Dual-Band Millimeter-Wave Frequency Synthesizer for Automotive Radars," *IEEE J. Solid-State Circuits*, vol. 44, no. 8, pp. 2100–2113, Aug. 2009.
- [11] Y. Chen, K. Mouthaan, and M. Geurts, "A wideband colpitts VCO with 30% continuous frequency tuning range using a tunable phase shifter," *2010 IEEE Int. Conf. Electron Devices Solid-State Circuits, EDSSC 2010*, pp. 5–8, 2010.
- [12] J. R. Bray and L. Roy, "Measuring the unloaded, loaded, and external quality factors of one- and two-port resonators using scattering-parameter magnitudes at fractional power levels," *IEEE Proc. - Microwaves, Antennas Propag.*, vol. 151, no. 4, p. 345, 2004.
- [13] J. Rollett, "Stability and Power-Gain Invariants of Linear Twoports," *IRE Trans. Circuit Theory*, vol. 9, no. 1, pp. 1–4, 1962.