

FISHER R C

AN ECOSYSTEMIC ROLE FOR ARCHITECTURAL STYLE:
BEARING 'THE PLAN' IN 'MIND'

PhD

UP

1992

AN ECOSYSTEMIC ROLE FOR ARCHITECTURAL STYLE:
BEARING 'THE PLAN' IN 'MIND'

by
ROGER CHARLES FISHER

Submitted in fulfilment of part of the
requirements for the degree
Philosophiae Doctor (PhD Architecture)
in the Faculty of Science
UNIVERSITY OF PRETORIA

OCTOBER 1992

'Architecture has nothing to do with the "styles"
(Le Corbusier, 1986[1923]:47).

For Mom and Dad

ACKNOWLEDGEMENTS

To be involved in tertiary education is a privilege. To teach that for which one was merely trained to practice is an exciting voyage of discovery. My time in teaching matches almost my extended time of being formally taught in the discipline. I have 'learnt' architecture twice, once by rote and once in humility. To thank all by name would be difficult.

All my educators at all times,
my colleagues, of all institutions and in practice,
my students past and present,
my friends and my family

share in the achievements of this study. They have all mostly borne and sometimes dragged me through difficult times. Even when I was floating they were there.

The technical demands of producing this document are such that if Kobie Olivier, Rosa Olivier, Frank Gaylard, Francois Swanepoel, Elaine Silver and Eve Stanley had not helped it would never have happened. To them my gratitude.

All the librarians of the Merensky Library, 'en by name' Annetjie Greyling, Hannie Bezuidenhout, Gerda Pretorius and Carin le Roux, have not only been helpful but also supportive. To all of them my appreciation.

The bursars Neill Powell and Neill are hereby acknowledged for their 1990 award.

Schalk le Roux, as Subject Co-ordinator of Environmental History, through friendship and example, having himself trod the path, made the study less formidable and highlighted its pleasures.

Prof. Dieter Holm has been instrumental in introducing me to a particular manner of thinking. This, in consolidating my own catholic interests, has not only been intellectually satisfying but also enriching. He has been inspirational, critically astute, mindful of my failings and tolerant of my iconoclasms. I could and would have had no other mentor for this particular study.

CONTENTS

	PAGE NO.
CHAPTER 1 : THE STUDY PROPOSAL	1
1. THE PROBLEM AND ITS SETTING	1
1.1 THE STATEMENT OF THE PROBLEM	1
1.2 THE MAIN HYPOTHESIS	1
1.3 THE DELIMITATIONS	1
1.4 THE DEFINITION OF TERMS	1
1.5 THE ASSUMPTIONS	2
1.6 THE MATERIAL, ITS TREATMENT AND ITS INTERPRETATION	2
1.7 THE CRITERIA GOVERNING THE ADMIS- SIBILITY OF THE MATERIAL	3
1.8 THE RESEARCH METHODOLOGY	3
1.9 THE IMPORTANCE OF THE STUDY	3
1.10 THE QUALIFICATIONS OF THE RESEARCHER	3
 CHAPTER 2 : THE ECOLOGY OF THE ARTEFACT	 4
2.1 SUBPROBLEM 1	4
2.2 HYPOTHESIS 1	4
2.3 OUTLINE OF CHAPTER 2	4
2.4 BACKGROUND	5
2.5 INTRODUCTION	5
2.6 WHAT'S IN A NAME?	7
2.7 SOME POSTULATES OF THE ECOSYSTEMIC MINDSET	9
2.8 SOME TERMINOLOGY	10
2.9 THE 'NESTING' OF SYSTEMS	11
2.10 THE BIOLOGY OF THE ARTEFACT	13
2.11 BEARING THE ARTEFACT IN 'MIND'	18
2.12 VISUAL THINKING	19
2.13 VISUAL 'GRAMMAR'	20
2.14 SUMMARY	21
2.15 CONCLUSIONS	22
 CHAPTER 3 : A SENSE OF 'STYLE'	 23
3.1 SUBPROBLEM 2	23

3.2	HYPOTHESIS 2	23
3.3	OUTLINE OF CHAPTER 3	23
3.4	INTRODUCTION	24
3.5	PLAIN WORDS	24
3.6	THE ETYMOLOGY OF 'STYLE'	25
3.7	LINES OF THOUGHT	26
3.8	'STYLE' IN ARCHAEOLOGY	27
3.9	ISOCHRESTIC STYLING	27
3.10	SKEUOMORPHIC STYLING	28
3.11	ICONIC STYLING	28
3.12	GOMBRICH AND 'STYLE' SCEPTICISM	29
3.13	THE OBJECTION TO HISTORICISM	31
3.14	STYLE CHANGES	33
3.15	THE CANONISING OF ICONIC STYLE	35
3.16	THE NAMING OF STYLES	37
3.17	THE INTERPRETATIVE HIERARCHY	38
3.18	AN ECOSYSTEMIC SENSE OF 'STYLE'	39
3.19	SUMMARY	41
3.20	CONCLUSION	42
CHAPTER 4 : THE ICONOGRAPHY OF 'THE PLAN'		43
4.1	SUBPROBLEM 3	43
4.2	HYPOTHESIS 3	43
4.3	OUTLINE OF CHAPTER 4	43
4.4	INTRODUCTION	44
4.5	THE PLAN BY DEFINITION	45
4.6	THE MUSICAL ANALOGY	45
4.7	THE ANACHRONIC PLAN	47
4.8	THE PLANS OF ANTIQUITY	48
4.9	THE MEDIEVAL PLAN	50
4.10	FROM THE RENAISSANCE TO THE PRESENT	51
4.11	THE CONTEMPORARY PLAN	52
4.12	SUMMARY	54
4.13	CONCLUSION	54
CHAPTER 5 : THE ICONOLOGY OF THE PLAN		56
5.1	SUBPROBLEM 4	56

5.2	HYPOTHESIS 4	56
5.3	OUTLINE OF CHAPTER 5	56
5.4	INTRODUCTION	57
5.5	THE PHENOMENOLOGICAL PLAN	57
5.6	THE PERCEPTUAL PLAN	58
5.7	THE HOMOSPACIAL PLAN	59
5.8	THE PLAN OF PLACE AND PATH	60
5.9	THE PLAN OF TYPES	60
5.10	THE ARCHETYPAL PLAN	61
5.11	THE NARRATIVE PLAN	61
5.12	ARTICULATION	63
5.13	THE SPACE-FORCE FIELDS OF THE PLAN	64
5.14	THE PLAN AS IMAGE	64
5.15	THE PLAN AS SIGN	65
5.16	THE PLAN AS SYMBOL	66
5.17	THE PLAN AS ICON	67
5.18	THE REPRODUCED PLAN	71
5.19	SUMMARY	71
5.20	CONCLUSION	72
CHAPTER 6 : THE TRADITIVE PLAN		74
6.1	SUBPROBLEM 5	74
6.2	HYPOTHESIS 5	74
6.3	OUTLINE OF CHAPTER 6	74
6.4	INTRODUCTION	75
6.5	ENGLISH PALLADIANISM	77
6.6	FROM PALLADIANISM TO PICTURESQUE	78
6.7	FROM PICTURESQUE TO PRAIRIE STYLE	79
6.8	THE DEMISE OF TRADITION	80
6.9	FROM TABULA RASA TO REGIONALIST REACTIONS	81
6.10	TWO CONTEMPORARY INTERPRETATIONS	82
6.11	SUMMARY	83
6.12	CONCLUSION	83
CHAPTER 7 : THE INTERACTIVE PLAN		85
7.1	SUBPROBLEM 6	85
7.2	HYPOTHESIS 6	85

7.3	OUTLINE OF CHAPTER 7	85
7.4	INTRODUCTION	86
7.5	THE SYMPATHETIC HOUSE	88
7.6	THE COSMIC HOUSE	89
7.7	THE SYMBIOTIC HOUSE	91
7.8	THE MECHANISTIC HOUSE	92
7.9	THE ECOSYSTEMIC HOUSE	96
7.10	SUMMARY	99
7.11	CONCLUSION	99
CHAPTER 8 : RECAPITULATION, CONCLUSION AND ACHIEVEMENTS		101
8.1	RECAPITULATION	101
8.2	CONCLUSION	107
8.3	DELIMITATIONS AND COUNTER-ARGUMENTS	111
8.4	ACHIEVEMENTS	112
CHAPTER 9 : SPECULATIONS AND OPPORTUNITIES		114
9.1	OUTLINE OF CHAPTER 9	114
9.2	INTRODUCTION	114
9.3	THE CULTURAL AUTOPOIESIS OF EDUCATION	114
9.4	EDUCATION AND THE DESIGN DISCIPLINES	115
9.5	DEVELOPMENTAL RECAPITULATION	117
9.6	HOLOGRAMMIC THOUGHT	118
9.7	TEACHING THROUGH PARADIGMS	121
9.8	THE MIND OF THE HISTORIAN	122
9.9	THE HISTORIAN AS CULTURAL HOMEOSTAT	123
9.10	A SYNOPTIC HISTORY	124
9.11	SIGNIFICANT METAPHORS AND ICONS	125
9.12	LIBERTY THROUGH HISTORY	125
9.13	THE ARCHITECTURAL CURRICULUM IN AN ECOSYSTEMIC PARADIGM	126
9.14	SUMMARY	127
9.15	CONCLUSION	127

LIST OF FIGURES

NOTE : Figure 4.1 is not referred to directly in the text but supports the observations of Chapters 2.12 and 2.13 (19 & 20) and Bateson's 1980 'Multiple Versions of the World' (119).

	PAGE NO.
FIGURE 2.1 The successive levels of organisation (Laslo,1987:49)	12
FIGURE 2.2 The stratified structure of the real world (Riedl,1984:182)	12
FIGURE 2.3 Chimpanzee's use of tools in nature (Riedl,1984:181)	13
FIGURE 2.4 The nest of the bower bird (Gombrich, 1979:plII)	15
FIGURE 2.5 The relationship between plumage and bower development (Hansell,1984:77)	15
FIGURE 2.6 The motif of the sacrificial tortoise as plan for the capital of London (Guidoni,1978:302)	16
FIGURE 2.7 'Marcus standing', contour drawing (Beukes,1992)	19
FIGURE 2.8 'Marcus standing', as 'figure' (Beukes,1992)	19
FIGURE 2.9 'Marcus standing', as 'ground' (Beukes,1992)	19
FIGURE 2.10 'Tina curled asleep', detail (Fisher, 1992a)	19
FIGURE 2.11 'Tina curled asleep' (Fisher,1992a)	19
FIGURE 2.12 Hagia Sophia - line drawing, axonometric plan (Meiss,1992:24)	20
FIGURE 2.13 Hagia Sophia - shadow drawing of ceiling (Meiss,1992:23)	20
FIGURE 2.14 Hagia Sophia - plan-figure (Meiss, 1992:23)	20

FIGURE 2.15	Hagia Sophia - plan-ground (Meiss, 1992:23)	20
FIGURE 3.1	The analogy of word evolution to that of knives (after Steadman, 1979:164)	25
FIGURE 3.2	The range of marks developed by Summerian Scribes (Kramer,1968:131)	25
FIGURE 3.3	Two kinds of stylus and a book of wax tablets (Hadas,1966:105)	25
FIGURE 3.4	Sand-drawings of the New Hebrides (Guidoni,1978:130)	26
FIGURE 3.5	Wonderboom Late Acheulean handaxes (Mason,1969:173)	28
FIGURE 3.6	Blaaubank Earlier Sangoan handaxes (Mason,1969:190)	28
FIGURE 3.7	Blaaubank Later Acheulean handaxes (Mason,1969:199)	28
FIGURE 3.8	Skeuomorphs of timber construction in architecture (Steadman,1979:118)	28
FIGURE 3.9	Six Petrarchan Triumphs - Love, Chastity, Death, Fame, Time, Divinity. C15 Florentine engraving (Gombrich, 1972:pl.143)	29
FIGURE 4.1	Chronological sequence of significant historical plans to the same scale. (Frigyes,1955:247-313)	43-111
FIGURE 4.2	Plan development from 'bubble-diagram' (Coetzee,1992)	44
FIGURE 4.3	Conventional plan representations - ground floor plan, Gildehuis, Nieuw Muckleneuk, Pretoria (Holm & Holm, 1986:Dwg. no.291 4/3)	45
FIGURE 4.4	J S Bach - Autographed manuscript copy of the Christmas Oratorio (in Werner, 1989:50)	46
FIGURE 4.5	Bach Christmas Oratorio - performing edition (Shering,1922(?):1&3)	46

FIGURE 4.6	Beaux-Arts reconstructed plan from classical antiquity (Labrouste in Drexler,1977:164&5)	47
FIGURE 4.7	Plan drawings of apse at Notre-Dame de Chalons - E E Viollet-le-Duc (in Steadman,1979:44)	47
FIGURE 4.8	Apses of Oen, Rouen (1318 - 1515) as shown by Banister Fletcher (in Palmes,1975:591)	47
FIGURE 4.9	A painting depicting an Amarna palace from the tomb of Mery-Re, high priest of Aten; XVIII Dynasty (Kostof,1977:9)	48
FIGURE 4.10	Landscape architect's ink sketch plan for a grove fronting the temple at El-Dier el Bahari; XI Dynasty (Porter,1979:1)	48
FIGURE 4.11	Marble fragment of the Urbis Romae (Giedion,1971:77)	49
FIGURE 4.12	Detail of Piranesi's map of Rome in his ' <u>Antichita romane I</u> ' (Scott, 1975:117)	49
FIGURE 4.13	Fragment of Roman bath in mosaic (Kostof,1977:33)	49
FIGURE 4.14	Monastery plan of St Gall (Kostof, 1977:72)	50
FIGURE 4.15	Detail from note book of Villard de Honnecourt (C13) (Lassus,1968:p.XXVII)	51
FIGURE 4.16	Drawing by J H Harvey of the tracing floor of Wells Cathedral (Porter, 1979:4)	51
FIGURE 4.17	'PLATE XIII Plan of the Theatre of Herodes Atticus, excavated on the side of the Acropolis at Athens. It corresponds in some respects with the directions given for the plan of the	

	Greek Theatre in Book V. Chapter VIII' (Vitruvius, 1874:pl.13)	52
FIGURE 4.18	An office development with leisure facilities and housing on the outskirts of the town of Chartres - competition entry Bernard Tschumi (1991) (Papadakis, 1992:42)	53
FIGURE 4.19	A night scene of an unbuilt Frank Lloyd Wright house by Intergraph (Ward, 1989:740-1)	54
FIGURE 5.1	Plan of the 1st floor of the Faculty of Economic Sciences, University of Pretoria (Pauw, 1991)	58
FIGURE 5.2	Students representations of the passageway on the 1st floor, Faculty of Economic Sciences building, UP ([1]Juby, 1992; [2]Scholtz, 1992; [3]Visser, 1992)	58
FIGURE 5.3	Eaton's 'Very approximate layout of Lamu town and island drawn from memory' (Eaton, 1949)	58
FIGURE 5.4	Three perceptual plans of Gildehuis and their superimposition (Kuhn, 1992)	59
FIGURE 5.5	The Temple of Rameses II, figure and ground image (Martienssen, 1976:121)	59
FIGURE 5.6	Nolli's map of Rome, detail, figure and ground representation (Meiss, 1992:93)	60
FIGURE 5.7	The modeling of Man's existential space in terms of points and paths ([1] Norberg-Schulz, 1971:21&3; [2]Norberg-Schulz, 1986:27)	60
FIGURE 5.8	The megarons of Tiryns (Palmer, 1975:188)	60
FIGURE 5.9	The Greek Megaron Temples (Huyghe, 1966:247)	60

FIGURE 5.10	Roman Basilica of Maxentius, C4 (Pevsner, 1972:44)	61
FIGURE 5.11	The basilica church of St Sabina, Rome (Norberg-Schulz, 1975:134)	61
FIGURE 5.12	The Earth four-square ([1]Stewart & Editors, 1971:16; [2]Lethaby, 1974:63;)	61
FIGURE 5.13	The paths of life ([3]Roux, 1983:28; [4] Kostof, 1985:193)	61
FIGURE 5.14	The sphere of heaven ([5]Gilot, 1962: pl. XVI; Jung, 1978:276)	61
FIGURE 5.15	A comparison of the structural bays of the Basilica of Maxentius, Rome and those of the Crystal Palace, London and their footprint analogies ([1]Sacriste, 1968:pl. 34&41; [2]Smithes, 1983:536&628)	62
FIGURE 5.16	A palimpsest of plans including a Roman Hoppodrome, Old St Peter's Basilica and New St Peter's Cathedral as depicted by Alfarani (Rasmussen, 1962:229)	63
FIGURE 5.17	The articulation of a Gothic Cathedral (Krier, 1988:369)	64
FIGURE 5.18	The Articulation of Ionic columns (Theodorescu, 1980:pp.147)	64
FIGURE 5.19	Some depictions of space force-fields after Portoghesi (Meiss, 1992:25, 113&115)	64
FIGURE 5.20	The Oikema at the Ideal City of Chaux, Ledoux (1987:pl.238)	65
FIGURE 5.21	The theatre at Epidauros (Meiss, 1992:17)	67
FIGURE 5.22	A plan of the theatre at Epidauros (Martienssen, 1976:126)	67
FIGURE 5.23	A schematic representation of the development of the Greek theatre form	67

FIGURE 5.24	Representations of the cross-shaped motif before 2000 BC (After Flinders Petrie 1930) (in Gombrich,1979:247)	68
FIGURE 5.25	Diagrammatic representation of the centralisation of the point of crossing in the Christian Church (after Norberg-Schulz,1986:13)	70
FIGURE 6.1	Villa Moncenigo, Palladio (1980:183)	77
FIGURE 6.2	Holkam Hall (1734-), Kent and Burlington (Wittkower,1974:122)	78
FIGURE 6.3	Fonthill Abbey (1976-), Beckford (Middleton & Watkin:1980:318)	79
FIGURE 6.4	Ward Willits House (1904-), Frank Lloyd Wright (Kaufmann & Raeburn, 1960:41))	79
FIGURE 6.5	A Country Home (1923), Mies van der Rohe (Blaser,1965:223)	80
FIGURE 6.6	House Kaufman (1946-), Richard Neutra (Cantacuzino,1970:28)	80
FIGURE 6.7	Martins House (1953-), Amancio d'Alpoim Guedes (Contacuzino,1970:154)	81
FIGURE 6.8	Niemeyer House (1953-), Oscar Niemeyer (Contacuzino,1970:146)	82
FIGURE 6.9	House Biermann (1961-), Barrie Biermann (Beck,1985:47)	82
FIGURE 6.10	De Silva House (1961-), Geoffrey Bawa (Taylor,1986:11)	82
FIGURE 7.1	The evolution of the round hut in Southern Africa (detail from Frescura,1981:20)	86
FIGURE 7.2	Varieties of round huts from pre-history to the present ([1]Camesasca, 1971:22; [2]Rykwert,1972:174; [3]Hall,1987:54; [4]Fisher,1992b:2&3; [5]Corbeil,1986:159; [6]Kahn, 1973:16)	86

FIGURE 7.3	An aerial photograph of an Iron Age settlement at Klipriviersberg (Mason, 1969:399)	89
FIGURE 7.4	A representation, after Kuper of the 'Bantu cattle pattern' showing the symbolic significance of left/right, up/down and centre/side (Hall, 1987:73)	89
FIGURE 7.5	A reconstructed dwelling, Blantyre Cultural Museum, Malawi showing places of significance (Bakker,1991)	89
FIGURE 7.6	A reconstruction of an Upper Palaeolithic dwelling in the Ukraine (Howell & Editors,1970:152)	90
FIGURE 7.7	Diagrammatic plan of an Etruscan tumulus (C7-5 B.C.) (Giedion,1971:60)	90
FIGURE 7.8	The 'Treasury of Atreus', Mycenae (c.1325 B.C.) (Giedion,1971:51)	90
FIGURE 7.9	The mausoleum of Hadrian, Rome (A.D. 139) (Palmes,1975:316)	91
FIGURE 7.10	S. Constanza, Rome (A.D. 330) (Palmes, 1975:368)	91
FIGURE 7.11	Pantheon, Rome (A.D. 120-4) (Martienssen, 1976:131)	92
FIGURE 7.12	Plate 8 of <u>Carceri d'invenzione</u> , Piranesi (c.1761) (Penny,1988:54)	94
FIGURE 7.13	The architecture of death - Newton Cenotaph, Boullée (c.1780) and the Funerary Chapel, Fontaine (1785) (Rosenau,1976:52;Etlin,1987:102)	95
FIGURE 7.14	Bank of England - detail plan of banking halls, John Soane (1788-1833) (Architectural,1983:62)	95
FIGURE 7.15	Desert de Retz, floor plans of house for Racine de Monville, Francois Barbier (1774) (Middleton & Watkin,1980:184))	95

FIGURE 7.16	Dymaxion House, Buckminster Fuller (1927-) (Meller,1972:pl.7)	96
FIGURE 7.17	Geodesic Dome, Buckminster Fuller (1954-) (Meller,1972:pl.11)	96
FIGURE 7.18	'What we love and hate about our dome' 60ft Red Rocker's dome (1970) (Kahn,1973:138-9)	97
FIGURE 7.19	The Tower - Jung's home in Switzer- land (c.1920) (Jung,1977:opp.224)	98
FIGURE 7.20	The Electronic Hut - Twin Thatches living room, Kloofzicht, Pretoria (1887 and 1987)	99

CHAPTER 1

THE STUDY PROPOSAL

AN ECOSYSTEMIC ROLE FOR ARCHITECTURAL STYLE : BEARING 'THE PLAN' IN 'MIND'

1. THE PROBLEM AND ITS SETTING

1.1 THE STATEMENT OF THE PROBLEM

The main problem is to determine an ecosystemic rôle for the changing style of 'the plan', it being an artefact characteristic of the discipline of architecture.

1.2 THE MAIN HYPOTHESIS

The main hypothesis is that 'the plan' through style, has an ecosystemic rôle in the cultural realm.

1.3 THE DELIMITATIONS

Only Western culture will be examined and used to formulate and substantiate the relevant arguments.

1.4 THE DEFINITION OF TERMS

Note : '[]' in the text refers to the numbered dictionary meaning.

Ecosystemic - see pp. 7-13 for discussion.

His - see 'Man'

Man - 'a human being regardless of sex or age, considered as a representative of mankind, a person

(Collins,1979:[3]) which leads to the use of the determiner 'his'.

Mind - This is the integral term used for the unconscious, sub-conscious, conscious and self-conscious activities of the organ of the brain.

Plan - see p.45 for definition and p.54 for a synoptic definition.

Style - The word and its derivatives all have the neutral sense. An understanding of the word is given in Chapter 3.

All other terms will have their contextual Oxford English Dictionary meaning unless the discernment of meaning is integral to the study in which case it will be included in the discussion.

1.5 THE ASSUMPTIONS

It is assumed that records used to substantiate or illustrate the evidence are authentic and accurate.

1.6 THE MATERIAL, ITS TREATMENT AND ITS INTERPRETATION

1.6.1 The material will comprise writings and artefactual reproductions of the C20.

1.6.2 Writings not originally in English will be accessed through translation.

1.6.3 Artefacts will be investigated through the recording thereof, for example printed reproductions of plans, and photographic recording of visual material.

1.7 THE CRITERIA GOVERNING THE ADMISSIBILITY OF THE MATERIAL

Material which has been published in sources which are reputable and have academic credibility will be considered admissible.

1.8 THE RESEARCH METHODOLOGY

The methodology of research is in the heuristic and phenomenological school of thought. It is comprised of a literature survey and an assemblage of suitable examples for the purpose of supporting this thesis.

1.9 THE IMPORTANCE OF THE STUDY

The study is important in that it revives the debate on the role of style in the discipline of architecture. There is a need to understand style ecosystemically. The plan is used since it is a persistent and economic artefact of the discipline. Yet its role as bearer of encoded cultural material has not been specifically investigated or elaborated. If this is done then significant plans from the past can be identified and past ideas conveyed synoptically.

1.10 THE QUALIFICATIONS OF THE RESEARCHER

The candidate is a M Arch(Pret) graduate, currently Senior Lecturer at the Transvaal School of Architecture, University of Pretoria. Since commencing duties in July 1986 he has been teaching the eighth semester (fourth year) course in Environmental History to Architectural and Landscape Architectural students as well as lecturing in Building Science and acting as Design Studio Master.

CHAPTER 2

THE ECOLOGY OF THE ARTEFACT

2.1 SUBPROBLEM 1

The first subproblem is to determine the role of the architectural artefact in the cultural realm.

2.2 HYPOTHESIS 1

The first hypothesis is that the artefact has ecosystemic agency.

2.3 OUTLINE OF CHAPTER 2

A background to the study will be briefly given. A short presentation of Kuhn's 'paradigm' will be given. Evidence for the demise of the Mechanistic paradigm and the status of scientific knowledge will be outlined. The emergent paradigm will be termed the 'Ecosystemic Paradigm'. Some terms relevant to the Ecosystemic Paradigm will be defined. A setting out of the evolutionary hierarchy will be derived from Laszlo, Riedl and Jantsch. The place of the artefact, specifically the built artefact, will be discussed as regards the biological, sociobiological, cultural and mental realm. The artefact as 'meme bearer' and cultural agent will be explained. The mental realm of the artefact will be briefly outlined and a hierarchy of images will be determined.

2.4 BACKGROUND

The Transvaal School of Architecture, University of Pretoria, resorts in the Faculty of Natural Sciences. The planning disciplines are the only disciplines within the faculty which offer courses in history. The final course in Environmental History is directed at senior students of Architecture and Landscape Architecture, fourth and third year students respectively. The course has been developed by Professor Dieter Holm and modelled on the Metabletics of Dr J H van den Berg (1974). In attempting to formulate an intellectual frame of reference and to systematise the curriculum of the course there has also been a turning to T Kuhn as Science Historian and an appropriation of his formulation of paradigms. Only now is a meta-level of understanding being articulated in order to make accessible the particular approach followed by the School.

2.5 INTRODUCTION

'Informed people in the second half of the twentieth century are inundated by an ever-increasing flow of information: fragmented bits and pieces of an eternally changing puzzle that we venture to solve in order to gain fleeting glimpses of new realities. We are aware of a profusion of alternative modes of thinking, as no other people or civilization has ever been ... Our art, our science, and our world view are all eclectic. Our concepts and ideas are littered with parts and pieces - some well petrified, some warm, and some still quivering - from other civilizations, past and present' (Dunning, 1991:213).

Our time has taken the postmodern turn. The term 'postmodern' has been appropriated throughout the disciplines, and is associated, not with a stylistic movement, but with a discomfort with the underlying premises of Western man's thinking. It is seen as

denoting 'an archaeological shift in the presuppositions of our thinking' (Palmer, 1977, 21), of being a 'condition' which has 'altered the ground rules for science, literature and arts' (Lyotard, 1981:xxiii). 'Postmodern science is one in which practical and theoretical issues, contemplation and action can no longer be separated' (Toulmin, 1982:264). We stand in a critical relationship to the time of the Modern. The tacit tenets of the Modern, in order to be critically assessed, are having to be made manifest.

Science, as it epitomised the discovery of 'truth' through the objective observation of physical reality which could be quantified and represented abstractly, became the ideal to which all disciplines aspired. The Humanities in attempting to achieve the status of Science copied the techniques of measuring and statistical analysis. This often led to the comic mimicking of scientific method, only to achieve trivial results. This provoked Barnes' (1963:385) observation that 'in future we probably shall have to differentiate more sharply between the true historian and the record clerk'.

Those of a post-modern bent view Science as a way of knowing which has specific validity and not as the paradigm of all knowledge. Heron (in Reason and Rowan, 1981:19-35) has offered the following as ways of knowing:

'Experiential knowledge is knowing an entity ... face-to-face encounter and interaction ... [and] through sustained acquaintance'

Practical knowledge is the knowing of "how to do".

Presentational knowledge involves grasping the 'whole' of perceptual experience, of orientating oneself in space and time which is then that 'spatio-temporal whole presented [as] the mark, the gesture, the signature, the "speech", of a presence'.

Propositional knowledge is where 'the outcome of research is stated in propositions, which claim to be assertions of facts or truths, a contribution to the corpus of knowledge statements'.

It is here accepted that all the above ways of knowing have validity and each is deserving of currency in the fullness of knowledge. If we are to grant validity to the full spectrum of knowledge then the ways of communicating our ideas about reality will need to be broadened. We are going to have to encourage and exploit the disciplines which are particularly dependant on other ways of 'knowing'. History as discipline would seem useful since it requires the scientific method for validating the artefactual record but once the corpus of factual material is analysed and categorised then it in turn requires meaningful interpretation.

Modern thought has come to be seen as the Mechanistic or Newtonian world view (Toffler in Prigogine and Stengers, 1986:xiii) and its tenets, or postulates those of the Scientific Imagination. But what is the emergent world view to be called?

2.6 WHAT'S IN A NAME?

Jan Smuts (1987) - who pioneered the intellectual framework for an integrated understanding of the

universe and our place therein - coined the term 'holism' for this. Unfortunately the term has been abused and overused.

Kuhn (1970) would have the term 'paradigm' appropriated for the intellectual milieu wherein ideas have viability. His original writings have been criticised for the equivocal usage of 'paradigm' (Shapere, 1964:383-94; Buchdahl, 1965:55-59; Masterman in Lakatos & Musgrave:1979:59-89). His 1970 postscript to the 1962 original writings have given a sense of the term which Gregory (1984:561-2) parallels with James' (1907) 'philosophic atmosphere' and Whitehead's (1985) 'circumambient atmosphere'. Laslo (1973:277-9) has seen 'style' in art as analogous with 'paradigms' in science and this has provoked a broadening of the understanding of the term. The following is a summary of a sense of the term derived from the above readings:

1. A paradigm is implicit and shared and directs the common endeavours of a community in its encountering of the phenomenological world at a particular time.
2. A paradigm is a property of man's abstract world. Its precepts are tacit and unformulated but direct the intellectual modelling of the community. It however exists beyond the meta-level of cognition and cannot therefore be articulated by the community. It is an endlessly regressive set of schemata that cannot be determined at will.
3. The paradigm, as a shared intellectual model, directs and limits the normal activities of the community. It is however important that it is in a state of dynamic equilibrium in order that the paradigm may adapt to altered circumstances of the community.
4. The paradigm will be exclusive of certain unshared schemata. If enough of these become shared a period of crisis will prevail.

5. A paradigm changes after a period of crisis and gives rise to a new paradigm which might be partly or wholly inclusive or exclusive of the previous paradigm'. [Kuhn's 'paradigm' in science can be extended as being the tacit directive of 'style' in the arts] (Fisher, 1989b:49-50).

In the 1980's the Mechanistic Paradigm came directly under assault. A plethora of terminology has been coined to describe what is now seen as the intellectual frame of reference for a new cosmology. Jantsch (1980), in the foreword to his 'The Self-Organizing Universe', provides the 'Who's Who' of the emergent paradigm-in-search-of-a-name. Names such as Bateson, Capra, Feyerabend, Laszlo, Prigogine, Riedl, Soleri (the architect!) and Waddington (his list is far longer) all lend the prestige of their fields of expertise to his enterprise. Some terms which have emerged are 'Systems Philosophy', 'Evolutionary Paradigm', 'Ecological Paradigm' and 'Ecocentric Paradigm'.

The root 'eco-' serves well as prefix in that it relates the emergent paradigm both to the issues of the day and the highest realm of biological activity, the home of man, his planet. As suffix '-system' is useful in that it incorporates the sense of process within the conceptual framework. 'Ecosystemic' as label seems a suitable conjunction because of its linguistic contemporaneity to the emergent World View. Ecosystemic Paradigm will serve as the name of the emergent paradigm for the purpose of this study.

2.7 SOME POSTULATES OF THE ECOSYSTEMIC PARADIGM

For the Ecosystemic Paradigm the following are accepted as postulates (or unquestioned premises): the patterns of organisation in all things inanimate and

living:

- are created according to their own internal nature; that is, natural laws determine the pattern-making.
- existing hierarchical structures which are ascendent in complexity, that is things can give rise to things more complex than themselves.
- are systems which have dynamic equilibrium and can be either entropic or negentropic, that is levels of greater complexity can evolve to higher energy or information states or become extinct.
- form part of an ascendant complexity, the evolution of which is a function of time, that is, that evolution is in the "arrow of time".
- are internal to the nature of one level of complexity and do not predict that of the next, that is novelty in organisation can arise spontaneously.
- have mechanisms of feedback or recursion (see below), that is matter is self regulating.

2.8 SOME TERMINOLOGY

The entire known universe, from sub-atomic particles up to human communities and their enterprises are encompassed by the Ecosystemic Paradigm. For the purposes of this discussion only those terms which have bearing on the cultural domain will be illuminated. These are:

autopoiesis - the regeneration by living systems

Opp. 11

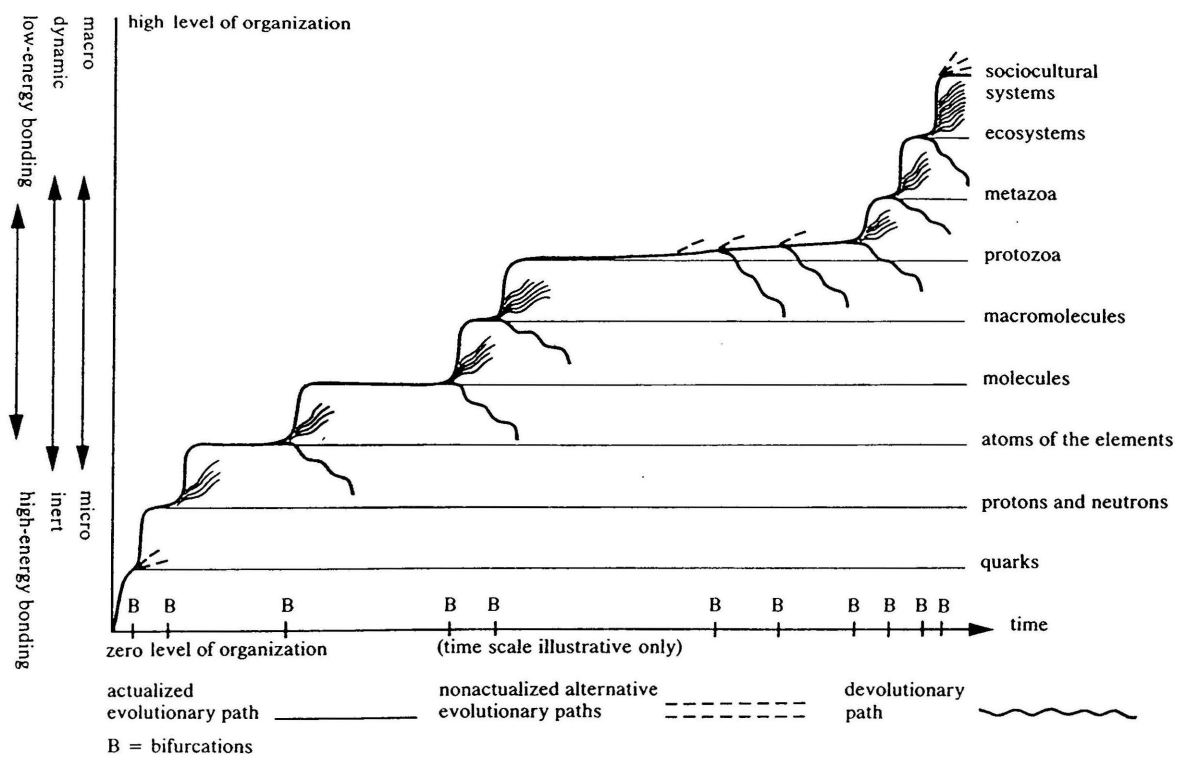

FIGURE 2.1 The successive levels of organisation.

of themselves (ascribed by Jantsch [1980:7] to the Chilean biologist Humberto Maturana).

homeostasis - the internal self-correcting mechanism of a system (ascribed by Bateson (1980:52) to the Frenchman Claude Bernard).

recursiveness - the process of systemic 'feedback' for achieving homeostasis (see above).

2.9 THE 'NESTING' OF SYSTEMS

Central to the emergent paradigm is the concept of systems.

'• The systems concept proves applicable to the description of those phenomena in living systems which defy description purely in terms of micro-mechanical cause-effect chain reaction; it thus lends substance to the principle of systemic organization.

• Applying the systems concept, an organism as a system reveals itself as encompassing and operating through the agency of sub-systems, each of which, in turn, contains and operates through groups of systems of still lower order, and so on down through molecules into the atomic and sub-atomic range.

• The fact that the top level operations of the organism thus are neither structurally nor functionally referable to direct liaison with the processes on the molecular level in a steady continuous gradation, but are relayed step-wise from higher levels ... [to] lower levels of again more rigorously ascertainable determinacy, constitutes the principle of hierarchical organization' (Weiss in Koestler and Smythies, 1969:33).

Rather than thinking of 'hierarchy' when referring to systems the idea of 'nesting' seems more useful. 'Hierarchy', literally the ordering of priestly power, still connotes a devolution of pyramidal power whereas

Opp. 12

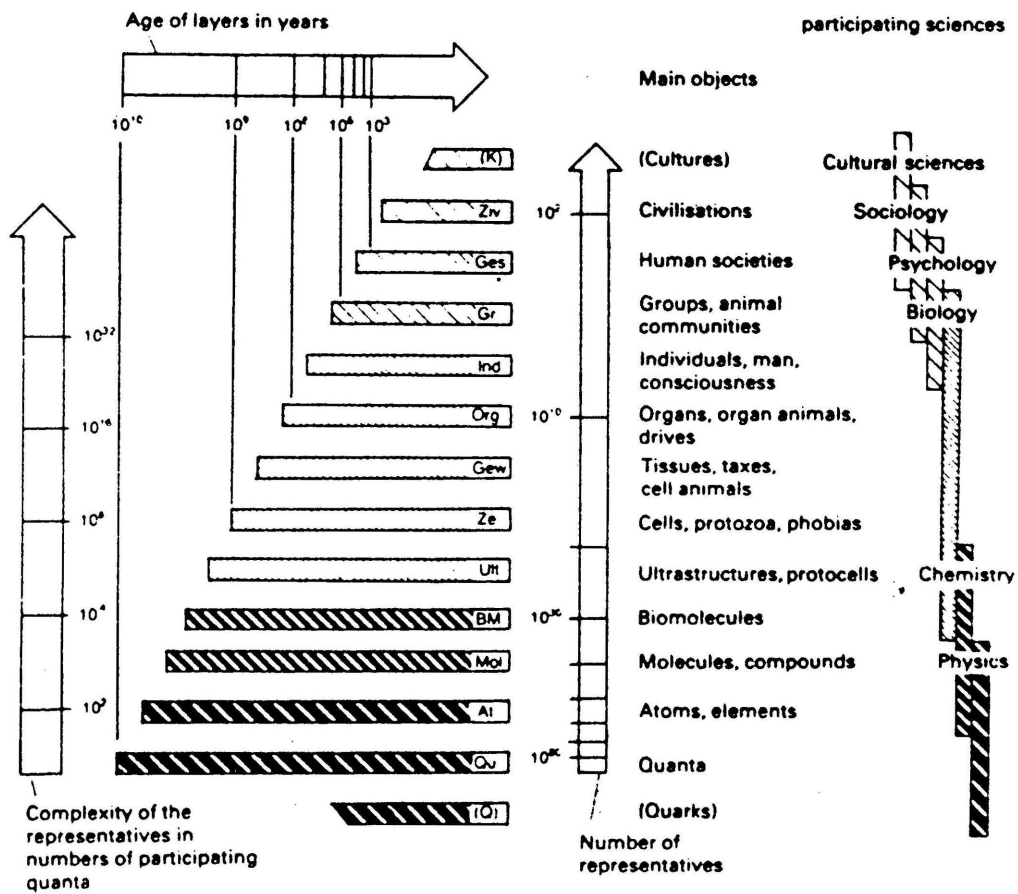

FIGURE 2.2 The stratified structure of the real world.

systems, being interactive, have influence in both the ascendant and descendant levels in which they are enwombed, much like Russian Dolls or Chinese Boxes. The term 'nesting' is preferred to emphasize this characteristic of systems.

The Ecosystemic Paradigm is an understanding of the universe in terms of a 'Grand Synthesis' of systems (Laszlo, 1987). Jantsch (1980) has called this universe 'Self Organising' and Riedl (1980) would see the increasing evolutionary complexity as a growth in the hierarchy of 'knowledge'.

Laszlo (1987:23) has set up the following hierarchy and related the bonding strength of the organisation of matter to time (figure 2.1):

'particles - atoms - molecules - macro-molecules
- protobionts - organisms - ecosystems -
sociocultural systems'.

Riedl (1984:183) offers the following evolution of the stratified structure of the real world (figure 2.2):

'? - Quanta - atoms - molecules - bio-molecules -
cell structures - cells - tissues - organs -
individual - group - human societies -
civilisation - culture'.

In order to discover an ecosystemic role for the artefact it is at first necessary to establish the realms wherein the artefact might be encountered.

Jantsch (1980) distinguishes between 'socio-biological' and 'socio-cultural evolution'. The co-operative processes of organisms are seen as being socio-biological. The socio-cultural realm is the co-operative system of man achieved through self-reflective behaviour.

Opp. 13



FIGURE 2.3 Chimpanzee's use of tools in nature.

If an artefact is considered to be the extension of the organism into its environment through the manipulation of the environment then biotic artefacts can be discovered within the biosphere as products of the activity of all organisms, from unicells right through to the sociocultural behaviour of man.

2.10 THE BIOLOGY OF THE ARTEFACT

Only man is a tool manufacturer although the exploitation of sticks to extract termites or reach edible fruit has been observed in the behaviour of chimpanzees (figure 2.3). Many creatures however build homes for themselves. Hansell (1984), following the lead of von Frisch (1975) has documented the building activities of creatures and offered theories as to the significance of such activity. If it is accepted that man shares in many of the traits of lower creatures, then it will be useful to examine some of the aspects of such building activity.

2.10.1 The Genetic Basis of Building Behaviour

'If artefacts have evolved through natural selection then:

- (a) building behaviour must have some genetic basis;
- (b) there must be variation within a population of builders in the nature of their artefacts;
- (c) differences in building style must result in differences in fitness between builders'

(Hansell, 1984:261).

It must be granted that if man did not have a genetic propensity for building then he would not be capable of such activity.

Opp. 14



FIGURE 2.4 The nest of the bower bird.

However through the acquisition of self-reflective mentation he is freed from the direct evolutionary consequences of 'fitness' which might have been achieved by the employment of differing building 'styles'. Yet the following paragraph, if read with the suggested insertions, would appear to hold true for man:

'Building behaviour must have some genetic basis; genetic change may therefore result in phenotypic novelty in the completed artefact. This novelty will then be exposed to the forces of natural selection. If advantageous it will prosper and become widespread, perhaps superseding the former architectural style. The appearance of an architectural feature in evolutionary history must indicate a change in the style of life of the builder, not just in the trivial sense that the building behaviour itself is different, but that the new style of building alters the constraints acting upon the animal [individuals]. This may permit it [them] either to use the artefact itself in a new way or to engage in other essential aspects of its [their] life differently. It would, of course, be quite misleading to give the impression that changes in architecture are the cause of other evolutionary changes. However ... changes in architecture may be accompanied by other changes in the lifestyle of the organism [individuals; community] ...'

(Hansell, 1984:236).

2.10.2 Protection From Climatic and Predation Hazards

'The function of mammalian artefacts is ... to provide protection from climatic and predation hazards' (Hansell, 1984:46).

Like the young of the European wild boar or the spotted hyena of Africa, the infants of man are born naked and helpless. Just as the young of the afore-mentioned species require protection in dens, so too the young of man require protection. When born man is still foetal, and certain

Opp. 15

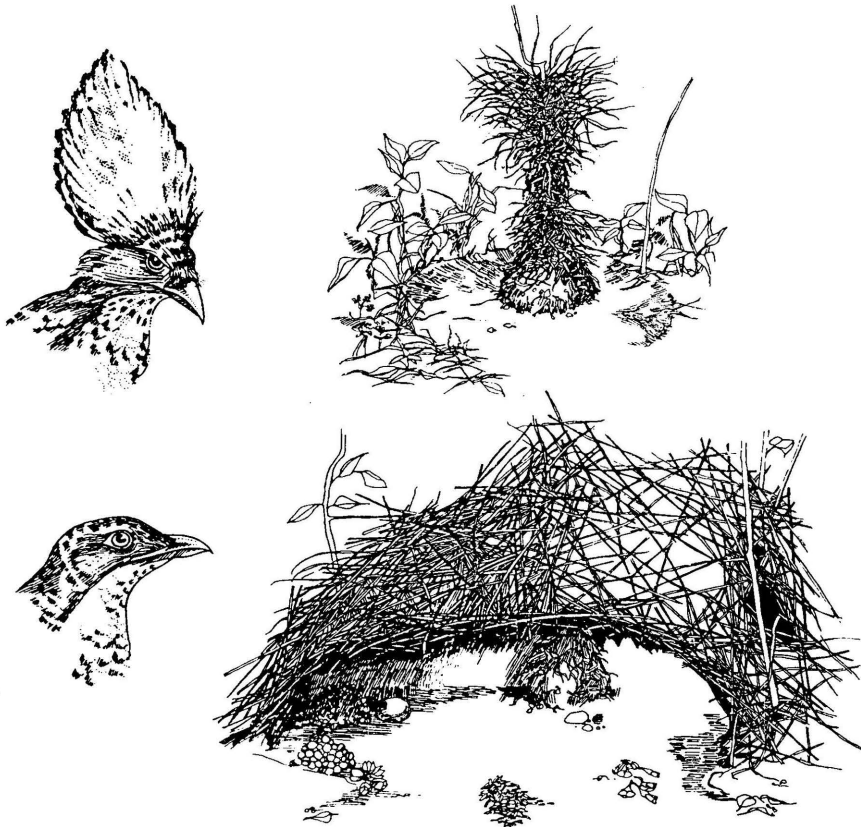

FIGURE 2.5 The relationship between plumage and bower development.

aspects of this foetal state or neotony, persist into adulthood. Man's persistent foetal nakedness is the sacrifice made to the enlarged cranium and balloon brain. The shelter which man builds for himself could be viewed as a surrogate womb to compensate for his never having acquired the coat of his cousins.

2.10.3 **Changes in the Function of the Artefact**

'One of the consequences of the generation of novel architecture is that it may come to fulfil a function, which it previously did not have' (Hansell, 1984:237)

'In the bower birds ... there seems little doubt that the bowers built by males serve only to enhance the attractiveness of the builder, [for] after mating, the female goes off and builds a breeding nest of her own ... The example of the bower bird shows the display becoming, partially detached from the animal ...' (Hansell, 1984:76-7). (Figures 2.4 & 2.5).

This detached functioning of the artefact is, for the study of man and his culture, the most significant. The artefact can operate in two separate ways. At the socio-biological level it can convey information as to the social structure of the community. This spacial disposition of the built structure is manifested even in the lowly ghost crab:

'The evolution of artefacts as social signals is simply a particular example of the evolution of any communicatory behaviour ... The male ghost crab ... builds a cone-shaped sand pyramid of material excavated from the home burrow. The pyramid is regular in form, steep-sided and positioned in a strict spatial relationship to the entrance of the burrow. The function of the pyramid, which is only built by males, is to deter the encroachment of rival males and to

Opp.16

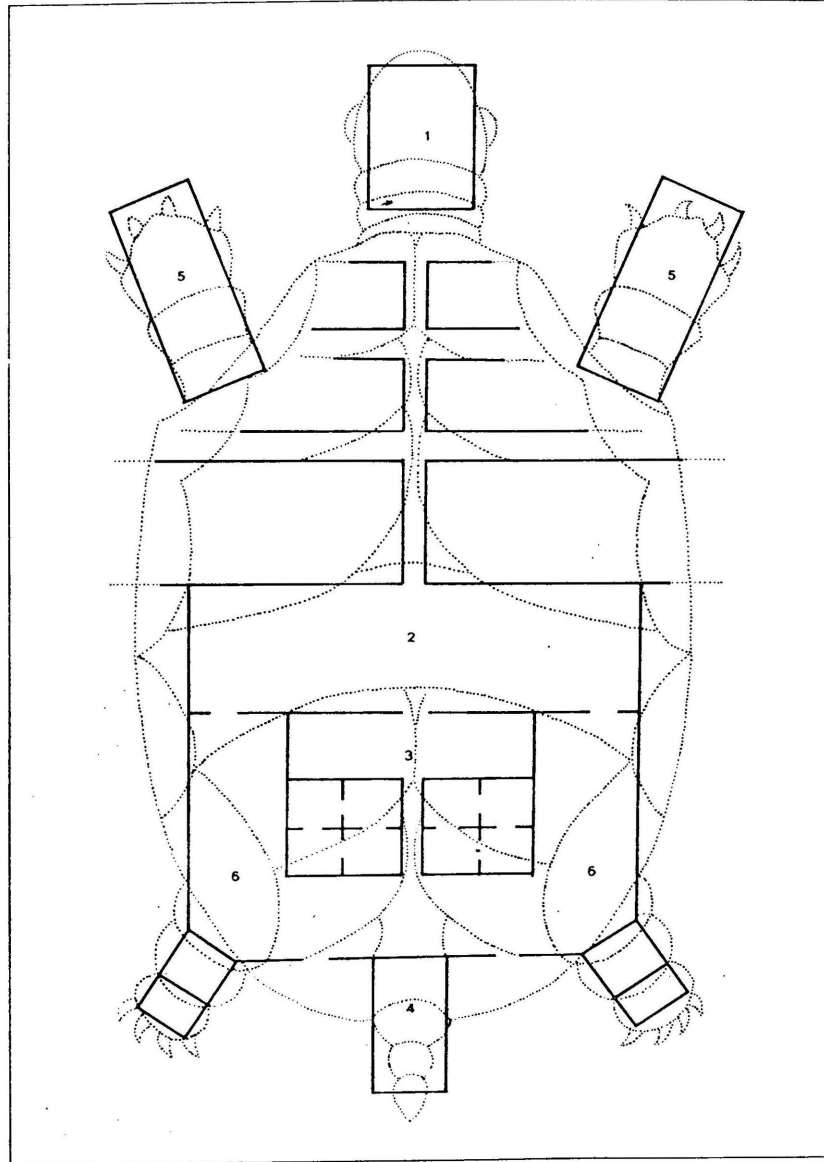

FIGURE 2.6 The motif of the sacrificial tortoise as plan for the capital of London.

attract females' (Hansell,1984:225).

We find the bio-social structure of communities reflected in the spacial disposition of dwellings of primitive cultures:

'In central southern Africa ... one [has] royal courts, which functioned for varying periods as territorial poles, drawing together the diverse political components of the "states". Those cities were primarily residences created to reflect the familial and bureaucratic power imposed on a number of subject lineages by the dominant lineage. Such a court, intimately connected with the person of the king, directly administered all nonagricultural activities and the judicial and military systems without ever bringing about the development of an intermediary class, a bourgeoisie that could confer urban characteristics on a central settlement ... Viewed thus, the court-city represents an extreme expansion of the concept of the dominant lineage, which uses totemic forms to lend credibility to its own power. An extremely clear example of this may be found in the plan of the ancient capital of the Lunda kingdom in central Africa, where the royal court buildings were organized according to the zoomorphic model of the tortoise [figure 2.6], we may visualize that capital less as a city than as an enormous house in which the familiars of the king and the most important functionaries assembled to exercise their power over the entire territory. [The tortoise is] present in its organization, and in extraordinarily overt form, was the concept of the dissection of the sacrificial animal as basis for the division of space, and for the division of the territory according to the cardinal directions. Here it was royal power that exploited the cultural substratum to demonstrate its own legitimacy to perpetuate the dynasty. Architecture was at the service of a single chief at the top of the social pyramid ...' (Guidoni,1978:296-7).

Although the socio-biological attributes of the artefact are significant, it is the second level

at which the artefact can operate, the socio-cultural level, which is the concern of this study.

2.10.4 **The Artefact as 'Meme' Carrier**

Dawkins, in 'The Selfish Gene' (1976), has posited the 'meme' which, as the cultural equivalent of the gene, is the unit or transference of cultural information. The gene can only transmute and follow the pattern of Darwinian evolution, that pattern of inheritance where only adaptively advantageous characteristics survive. The 'meme' has however the ability to be transformed in a Lamarckian way where characteristics are acquired and transmitted. Characteristics can be acquired in the immediate present or recaptured from a distant past, unlike genetic inheritance where only traits peculiar to the organism directly in the line of inheritance are transferable. Cultural changes are then not changes of accident but by design.

The 'meme' is understood as being the smallest recognisable cultural schema. The artefact can act as agent for such schemata or 'memes'. These are encoded during its fabrication. Through its message-carrying, or memetic, content the artefact is the agent of cultural homeostasis (or stabiliser) in its time, in that it is encoded with the values and meanings of its time and place. As such the artefact is active within the cultural system. The persistence of the artefact preserves its agency as message bearer. Past values and meanings can be continually transmitted into the present. Through

interpretation the memetic content of the artefact can be decoded and anachronistic ideas and meanings be reintroduced in novel fashion. Thus the artefact retains potency within the cultural realm as agent for cultural retrieval or change.

This view of the artefact is distinctly different from that within the Mechanistic Paradigm where the artefact was viewed merely as the curiosity of a bygone era sloughed off in its own time and unrelated to the time when rediscovered. Within the Ecosystemic Mindset the artefact is energised and its potency acknowledged. Past dead letters are literally revitalised.

But for 'memes' we do not only need artefacts but 'minds'. Thus to understand the significance of the artefact we need to know something of the nature of 'mind'.

2.11 BEARING THE ARTEFACT IN 'MIND'

Our understanding of the functioning of the brain was greatly enhanced by the pioneering studies of Sperry (1970) on split-brain patients. The discovery of the lateralisation of brain functions has given us the opportunity to speculate on the difference in abilities of the left and right sides of the brain.

The left brain, the centre of linearity or linear thinking, logic and language, is the brain best known to us since it is articulate and self revealing in its action. Its skills have been those required of 'Modern' man, that is the rational and mechanistic scientific mind which has given us the industrial world. It is therefore not surprising that in devising

Opp. 19



FIGURE 2.7

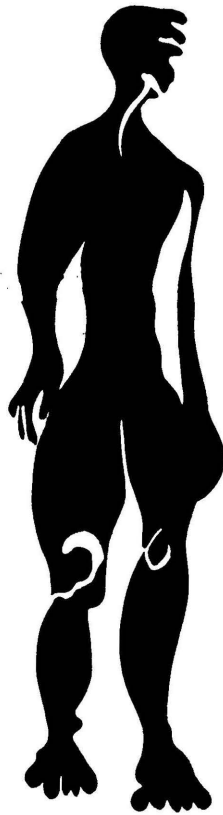

FIGURE 2.8

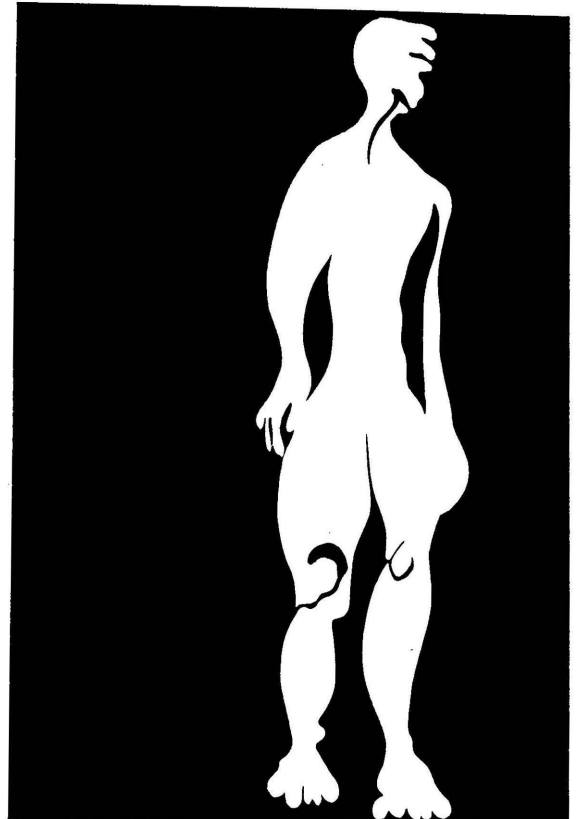

FIGURE 2.9

FIGURE 2.7 'Marcus standing', contour drawing.

FIGURE 2.8 'Marcus standing', as 'figure'.

FIGURE 2.9 'Marcus standing', as 'ground'.

theories of the ascent of the human mind in evolution that the development of language could be considered pivotal. It is only more recently that the 'intelligence' of the right hemisphere - that of integrative functioning, visual literacy, the synthesised present, and imagined futures - is being understood.

2.12 VISUAL THINKING

The evolution of culture has been paralleled by a diversification of representational drawing. Either through physiological inevitability or happy coincidence (these aspects of evolution tend to test credulity) the devices by which the human mind 'sees' manifests in the abstractions of drawings. It is therefore possible to stimulate recall by means of drawings alone. What are these devices?

The first is the outline, which matches the physiological or Mach effect whereby the contour of the object perceived is concentrated in the line of difference, the edge which distinguishes the object from its surround and whereby the object is recognised through its profile (figure 2.7).

The second derives from the distinction of the object from its surround where the object is recognisable through its silhouette or figure, and where the remnant area or surround is seen as background or ground to the object (figures 2.8 & 2.9).

The third representation derives from the reduction of the object to abstract planes of light and dark. The 'modelling' of the object is thereby reduced to a schema of shadow-light patterns (figures 2.10 & 2.11).

Opp. 20



FIGURE 2.10 'Tina curled asleep', detail.

FIGURE 2.11 'Tina curled asleep'.

There are ofcourse many other devices for capturing images pictorially but those that have been outlined seem to be the sufficient minimum for graphic representation and recall and are those employed to create the plan image (figures 2.12, 2.13, 2.14 & 2.15).

From the abstractions which derive from representation through line and form features are recognised by eliciting a response in the brain where these forms are stored in memory. The variety of images which are evoked will be cast as fishing nets (Mc Crone, 1990:34-63) by memory and the appropriate image ensnared for recognition in the fine matrix of their intersection. Another analogy would be that the brain will be troubled by each schema of recognition of form and that each schema, like pebbles in a pond, will cause a spreading ripple. Where all these ripples of response intersect and cause the greatest disturbance will be the recognition of the specific integrated form.

2.13 VISUAL 'GRAMMAR'

Through the constant re-use of pictures various images have undergone pictorial condensation leading to visual metonymy - for instance a crown used to symbolise the pharaoh, or synecdoche - for instance the horns used to symbolise the ox. From such devices arose what today is the alphabet.

Since the right hemisphere of the brain is 'dumb' (although it would seem to have a limited number of words available, such as expletives, those connected with emotional states) the hierarchy of imagery wherewith it deals can only be deduced by analogy.

Opp. 21

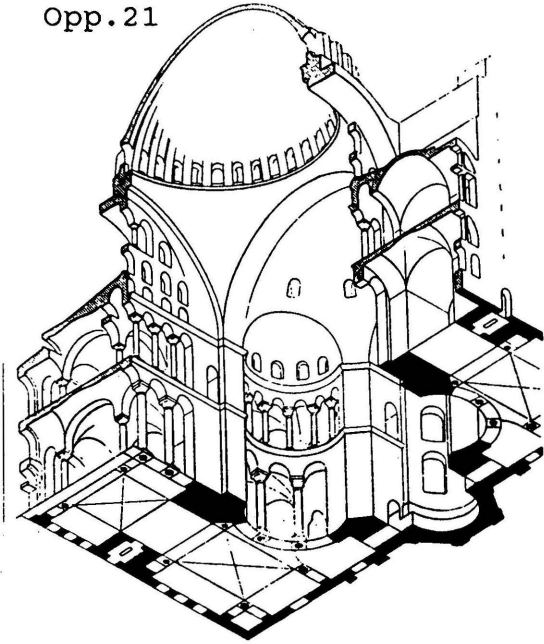

FIGURE 2.12

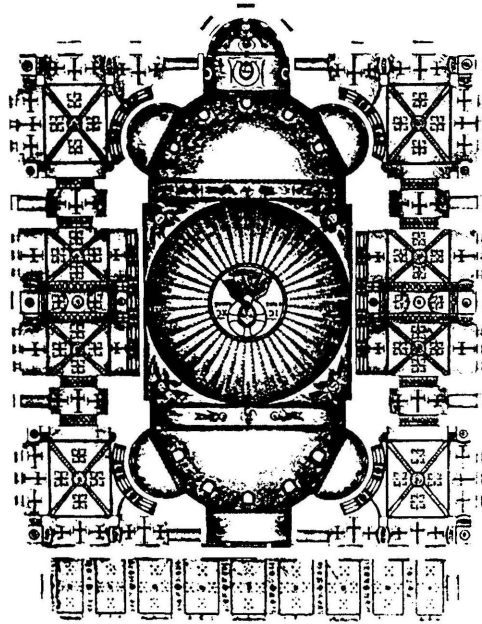

FIGURE 2.13

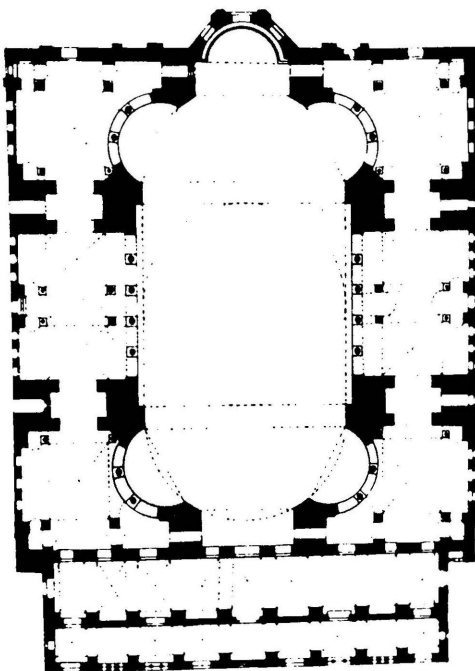

FIGURE 2.14

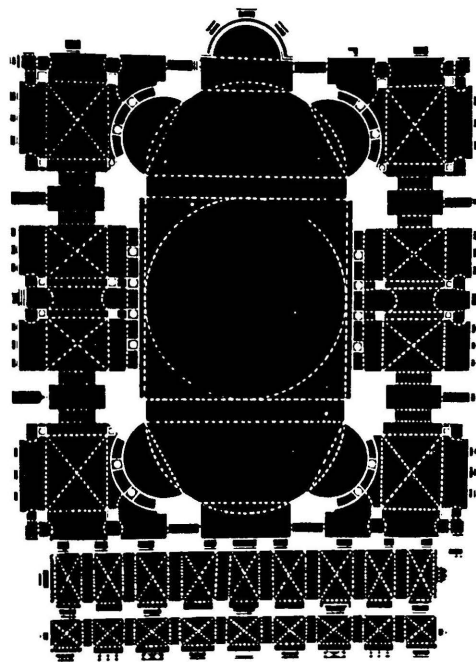

FIGURE 2.15

- FIGURE 2.12 Hagia Sophia - line drawing, axonometric plan.
- FIGURE 2.13 Hagia Sophia - shadow drawing of ceiling.
- FIGURE 2.14 Hagia Sophia - plan-figure.
- FIGURE 2.15 Hagia Sophia - plan-ground.

It is assumed that the manner of recording by the brain hemispheres is homologous. One could have, analogous to the hierarchy of language a similar hierarchy of images, from plain images through to what is an equivalent of the metaphor.

In language the hierarchy is as follows:

word, simile, analogy, metaphor.

In pictorial recall the imagery can be arranged hierarchically by analogy as follows:

image - 'a pictorial representation produced by the imagination' (Collins,1979:[4])

sign - '[a representation] that acts as a token of fact...' (Collins,1979:[1])

symbol - that which stands for something else by association or convention (Collins,1979:[1])

icon - a symbol analogous to that which is represented (Collins,1979:[3])

This is not an established hierarchy and is here presented by way of suggestion. The meanings ascribed are the conventional dictionary definitions. There would appear to be an implicit hierarchy through the employment of the terminology in the respective definitions. It is also accepted that usage outside of this study will require other meanings. The meanings given here will be the restricted understanding of the terms in this study.

2.14 SUMMARY

The ecosystemic view permits the placing of the artefact within a hierarchy of the biological realm, from the byproduct of biotic activity through to a

bearing of the imagined artefact in mind. The systemic activity of the level at which the artefact is examined will determine its ascribed significance. The greatest significance which the artefact can achieve is as cultural agent within the socio-cultural domain. Here the significance is abstracted into a hierarchy of image, sign, symbol and icon.

2.15 CONCLUSION

The first subproblem was to determine the role of the architectural artefact in the cultural realm.

The first hypothesis was that the artefact has ecosystemic agency.

The artefact within the socio-cultural realm is actively encountered by mindful individuals with the associated techniques of memory and recall. The role of the artefact within the cultural realm is that of meme bearer and as such it has ecosystemic agency. The hypothesis is thus supported by the arguments presented.

CHAPTER 3

A SENSE OF 'STYLE'

3.1 SUBPROBLEM 2

The second subproblem is to determine a sense of style within the Ecosystemic Paradigm.

3.2 HYPOTHESIS 2

The second hypothesis is that, through styling, artefacts are encoded with cultural significance.

3.3 OUTLINE OF CHAPTER 3

In Chapter 3 the etymology of 'style' will be given. The use of the term as proposed by Sackett will be discussed and his idea of isochrestic styling expounded. The nature of iconic styling will be contrasted with this. The idea of style in an historicist sense as objected to by Gombrich will be examined. Style change as proposed by Ackerman will be expanded. The naming of styles will be discussed. A hierarchy of style analysis will be presented. An ecosystemic sense of 'style' will be set out.

Opp. 24

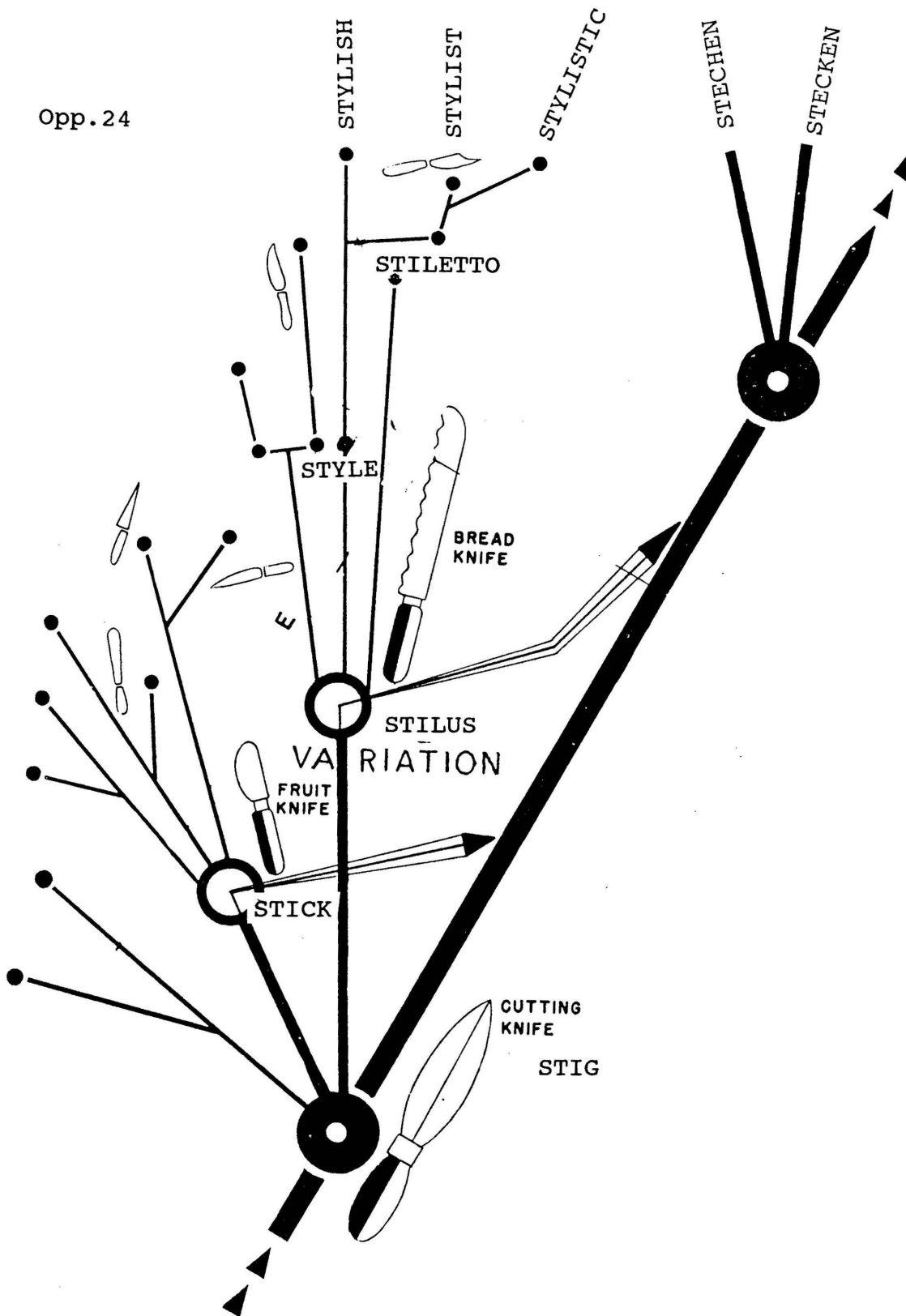

FIGURE 3.1 The analogy of word evolution to that of knives.

3.4 INTRODUCTION

The idea of style and style periods which had been expanded by the C18 and C19 style taxonomists was spurned by the C20 Modernists. They wished to ride the crest of an eternal future in a present ever nascent, ever new. The avante garde purveyed a series of innovations in rapid succession to ensure that these could never be canonised as style. This was a reaction (or over-reaction) to the C19 cannibalising of every identifiable style into an eclecticism of revivals.

The Mechanistic Paradigm, epitomised by the Modern, is now in the descendant, therewith the dogma of individual uniqueness and the promise of continuous progress. Within the Ecosystemic Paradigm the present is viewed as a palimpsest of all pasts and heir to a plurality of all possible knowledge. What sense should 'style' then have in the emergent Ecosystemic Paradigm?

3.5 PLAIN WORDS

If we accept that words are artefacts then we can discover the style of the words in their usage. Take for instance the following paragraph :

'At the stroke of five each morning Mother and Father leaped out of bed. Then they began to do many chores about the house. Before the sun rose Mother took water from the well while Father went out into the fields to feed the cows and look after the horses' (Maleska, 1983:170).

There are no words with roots foreign to English here. We have plain words in plain English which have their roots in the Anglo-Saxon language. Were these words implements then we would say they still serve the utilitarian purpose for which they were founded. Just

Opp. 25

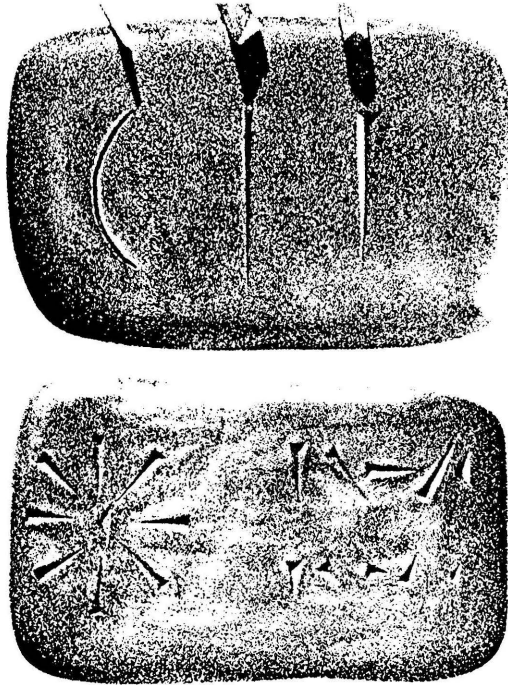
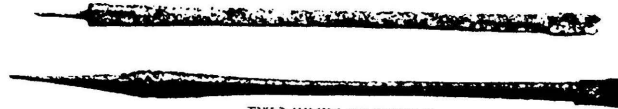

FIGURE 3.2



A BOOK OF WAX TABLETS



TWO KINDS OF STYLUS

FIGURE 3.3

FIGURE 3.2 The range of marks developed by Summerian Scribes.

FIGURE 3.3 Two kinds of stylus and a book of wax tablets.

as a knife is for cutting so the meaning of the words are incisive and without nuance. Yet there is a certain pedestrian blandness about what is being communicated.

Usage and circumstance give words associations beyond their original direct meanings. With time meanings become abstracted into simile and metaphor. As with the evolution of the knife the necessity for specific linguistic tasks requires specifically adapted meanings (figure 3.1).

3.6 THE ETYMOLOGY OF 'STYLE'

In attempting to discover the meanings of the term 'style' one can do no better than quote Lucas (1974:15-6) directly (with the relevant footnote included):

'What, in fact, is "style"? A dead metaphor. It meant originally "a writing-implement" - a pointed object, of bone or metal, for inscribing wax [figures 3.2 and 3.3].

Also, adds the Oxford Dictionary (with unintended irony), "used as a weapon of offence, for stabbing, etc." For the Latin stilus comes from the root STIG - cf. Greek σίζω, stigma, stimulus, instigate, stick, German stechen, stecken. We should, were English a logical language, write "stile" (cf. German Stil, Italian stile, Spanish estilo). But the Latin stilus became corrupted to stylus by confusion with the Greek στυλος "a pillar"; and this spurious "y" does at least save us now from confusing the "styles" of writers with the "stiles" of field-paths.

But already in Classical Latin the word stilus was extended to mean, first, a man's "way of writing"; then, more generally, his "way of expressing himself", in speech as well as in writing. In modern English, "style" has acquired further senses. As in French, it has been narrowed to signify "a good way of expressing

Opp. 26

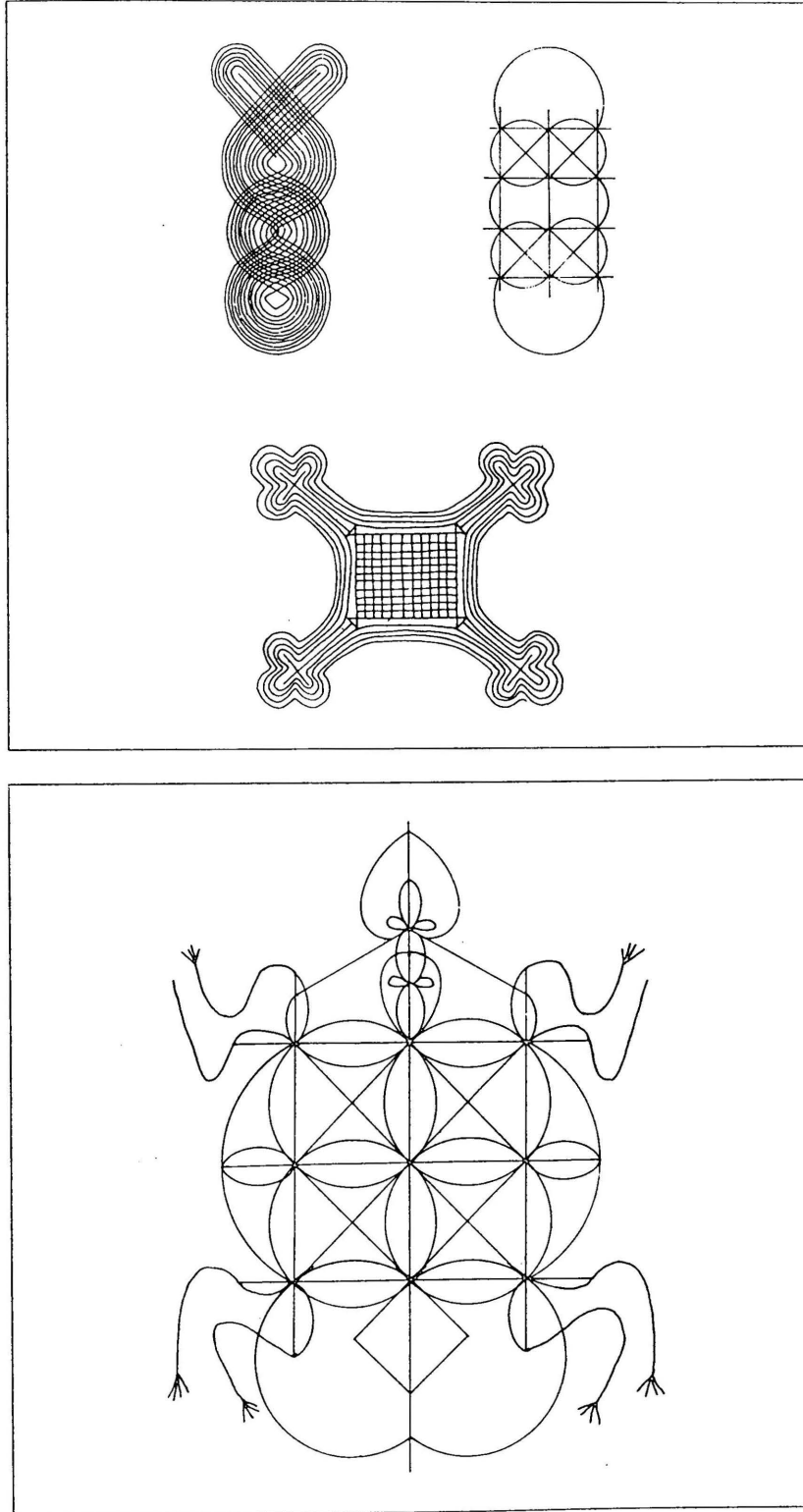

FIGURE 3.4 Sand-drawings of the New Hebrides.

oneself" - "his writing lacked style"; and it has been extended to other arts than literature, even to the art of living - "her behaviour showed always a certain style".'

3.7 LINES OF THOUGHT

Sticks and stones are the stuff of human culture. Through the Indo-European root 'stig', meaning 'stick', of the word 'style' we are linked to the proto-human crouched idly at the fire he has just mastered. The stick with which he coaxed life from the kindling he would idly draw through the sand and leave his first ephemeral mark.

In the scheme of things this mark became associated with mystical powers. The pygmies draw the image of their prey in the sand, which they then obliterate at the first light of day. Then they hunt, having enchanted the endeavour by the ritual (Frobenius, 1933:163). Once the prey is caught and hunger sated the exploration of the sand drawing as art fills the leisure of their success, so providing opportunity to engage in 'art' (figure 3.4).

The change from the transient techniques of sand drawing to stylus and clay is directly related to the change from the here-and-now culture of hunter-gatherer to the seasonal rhythm and forward planning of the agrarian.

Through the manner of his marking with his stylus in the clay man would identify himself through his style. And through the style of his writing - his petroglyphs, pictogrammes, hieroglyphs and electroglyphs (to coin a term) - he would identify the style of his culture.

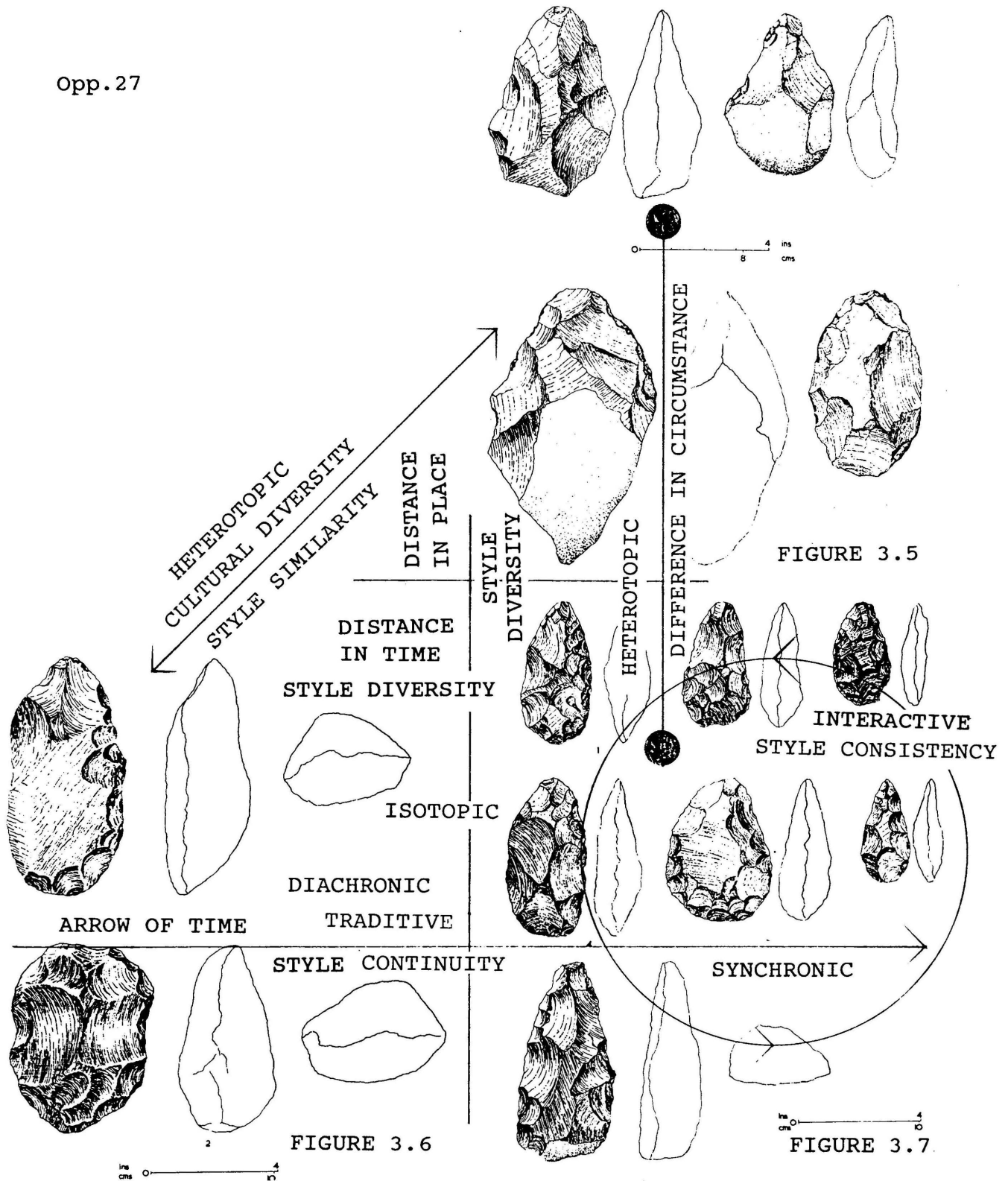

FIGURE 3.5 Wonderboom Late Acheulean handaxes.

FIGURE 3.6 Blaauwbank Later Acheulean handaxes

FIGURE 3.7 Blaauwbank Earlier Sangoan handaxes

We discover thus that style, both the term and the concept, is a huge metaphor through which we access our cultural memory.

3.8 'STYLE' IN ARCHAEOLOGY

It may be useful to consider how the term is used by the archaeologists. Sackett (1977:370) posits that:

'style

- (a) concerns a highly specific and characteristic manner of doing something, and
- (b) that this manner is always peculiar to a specific time and place'.

Hence to have 'style', we must have an enterprise - the 'doing' of something in time and place. If this 'doing' - that is 'manufacture' - results in an artefact rather than ritual - that is 'behaviour' - then the artefact can be said to embody the style of a time and place.

3.9 ISOCHRESTIC STYLING

'Style', when applied to the earliest and therefore essential level of culture, is seen to emerge where communities adopt a particular manner of doing, when there are various ways of doing, whereby to achieve the same utilitarian end. For this particular application of 'style' Sackett (1982:73) employs the term 'isochrestic' style, 'isochrestic' meaning literally 'equivalent in use', from Greek 'iso' - = even or equivalent and 'chrestein' = to use.

The individuals of a community engaged in the day-to-day 'doings' are mimicking the 'doings' of others. Their style is that of the community and as such is

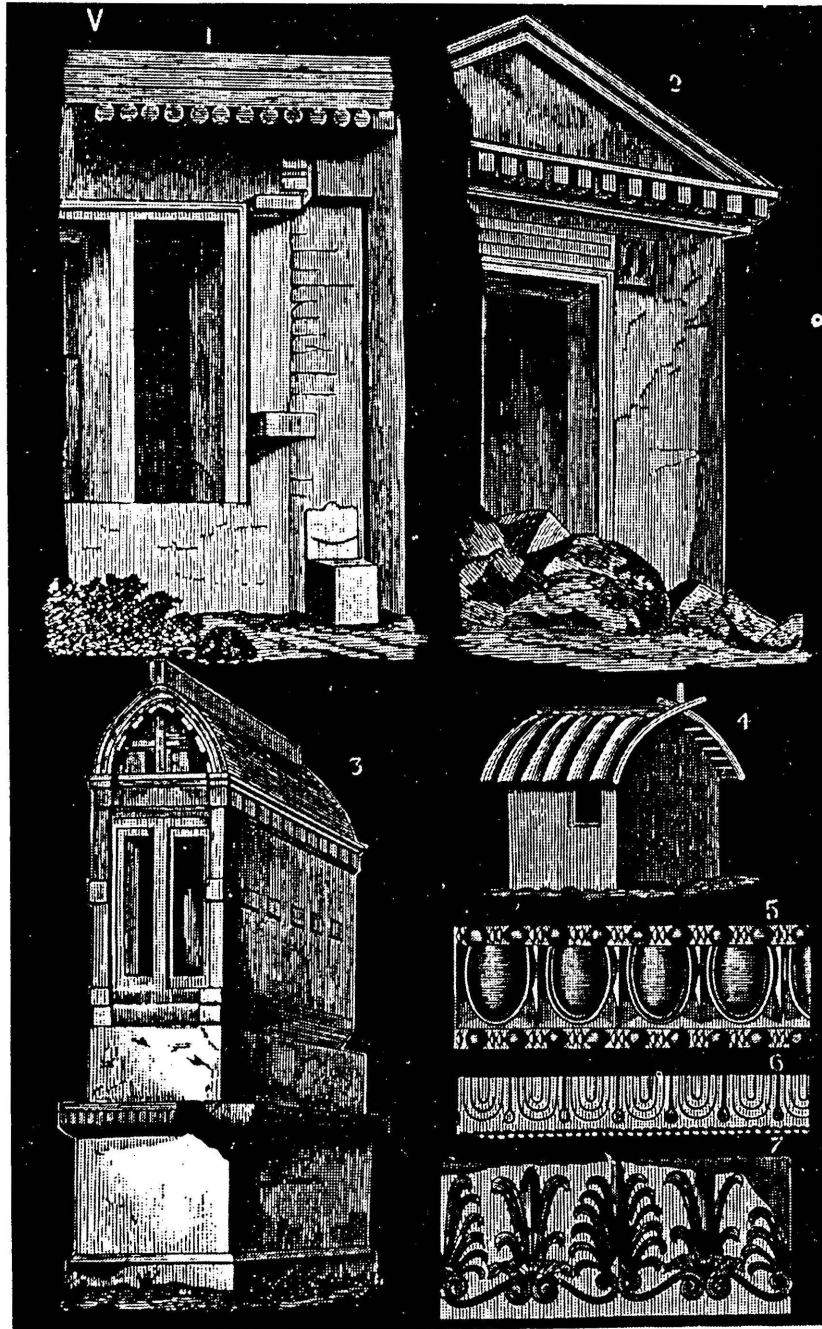

FIGURE 3.8 Skeuomorphs of timber construction in architecture.

facilitating social cohesion. If any choice is exercised it is subliminal and tacit. Thus if we discover style variation in functionally equivalent artefacts which are from the same time it indicates that they derive from different cultural groups (figures 3.5, 3.6 & 3.7).

3.10 SKEUOMORPHIC STYLING

Techniques of manufacture of prototypic artefacts can later serve as the source of its styling. This is termed 'skeuomorphic' styling, a 'skeuomorph' being a form which mimicks the making of the original, from the Greek 'Skeuein' = to hide and 'morph' = form. Steadman (1979:112) attributes the use of the term to Colly March of the late C19, but he is thought to have got it from the contemporary Sir John Myres.

The best known 'skeuomorph' in architecture is the triglyph which derives from the beam ends of timber prototypes (figure 3.8). Much of ornamentation derives from skeuomorphic styling which is readily copied and perpetuated and adopted by other cultures. Gombrich (1979) in 'The sense of order' gives an expansive account of decoration as art and has identified nature and geometry as the source of all such styling.

3.11 ICONIC STYLING

By contrast, the deliberate and conscious styling of the artefact is termed 'iconic' styling, iconic meaning 'having formularised style' which derives from the Greek root 'eikon' meaning 'image' and is allied to the idealised Greek memorial statues and busts of victorious athletes (American:1970). Hence the elaborate styling of the utilitarian artefact, or artefact destined for secular or religious ceremony

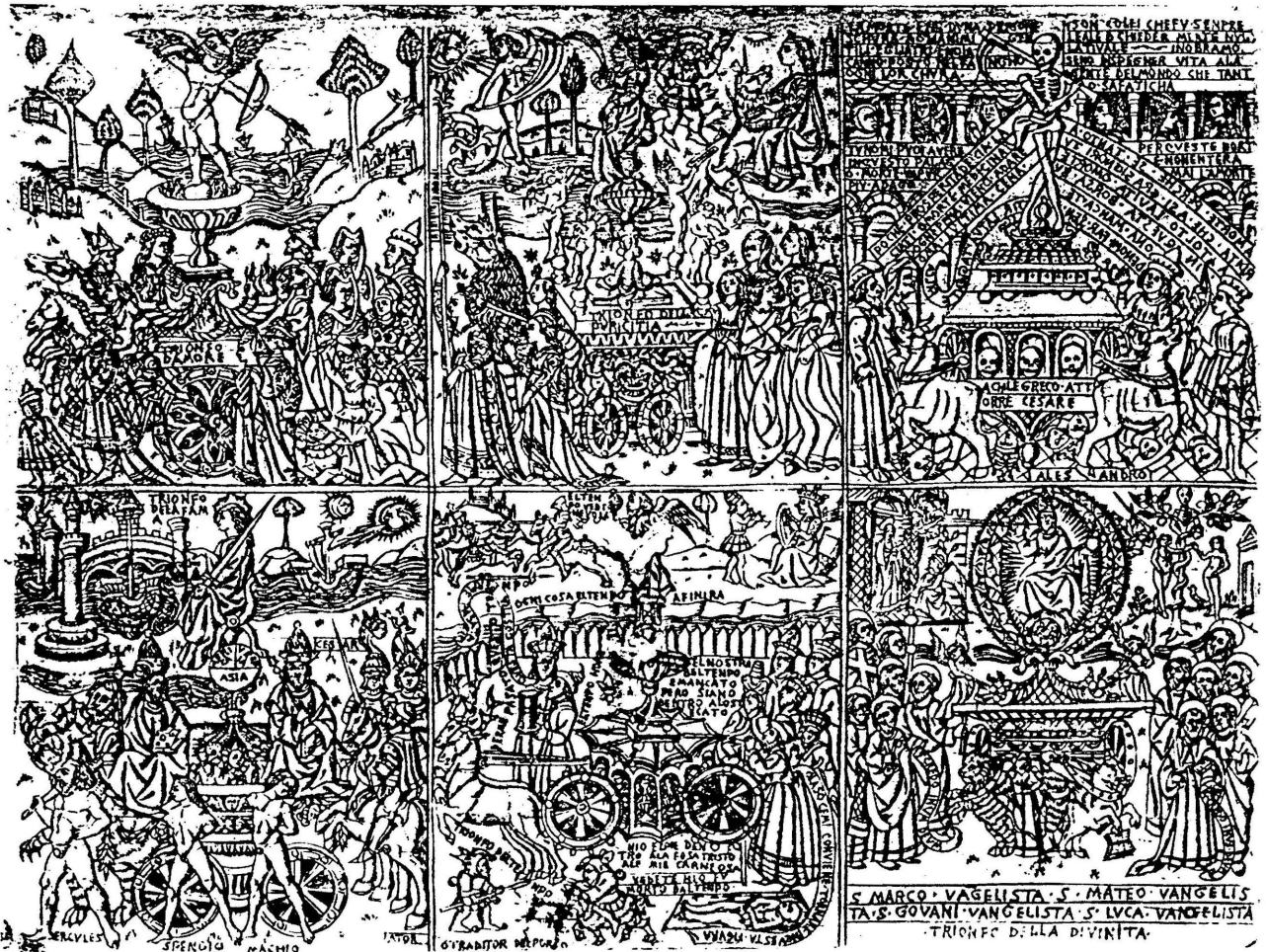

FIGURE 3.9 Six Petrarchan Triumphs - Love, Chastity, Death, Fame, Time, Divinity. C15 Florentine engraving.

will be iconic. Works of 'art' are those artefacts created purely as medium for iconic styling since the sole objective is the encoding the artefact with symbolic significance.

The European Middle Ages, particularly in the C12 and C13 had produced the most integrated programme for iconic styling encompassing all manner of artefacts over a broad geographic spread. Digby (in Knights and Cottle, 1960:39) cites Emile Mâle's exposition of the comprehensive hierarchical employment of a complex symbol system by philosophers, theologians and artists and craftsman of that time:

'Four levels of understanding were distinguished: (1) historical, (2) allegorical, (3) tropological - in which the image was understood symbolically in terms of the psychology of religion (Jerusalem=soul; Job=its trials), (4) anagogical - which referred to the highest meanings where there was a spiritual or mystical content' (figure 3.9).

This illustrates the degree of complexity and sophistication which can be attained in a mature and cohesive culture through conscious or iconic styling.

3.12 GOMBRICH AND 'STYLE' SCEPTICISM

Gombrich (1979:216) in his Chapter 'The psychology of style' has raised a number of objections to various interpretations of 'style'. His first objection is to the 'inner logic' of style where the logical cohesion of every 'great' style could be seen as 'a vast deductive system' (Gombrich, 1979:199) as expounded by Riegl and Viollet le Duc.

'No wonder the study of styles was coloured by this quest for inner cohesion and unity. Its roots lie in the situation [an escape from the round of historical styles] of the nineteenth

century' (Gombrich, 1979:197).

This may explain the necessity of such a theory but does not invalidate their arguments for it.

Gombrich is even more vigorously opposed to the idea of an effluorescence of style in art as being indicative of cultural superiority. Transferring the idea of the style of a graphologist to that of art

'implies a belief in some kind of collective spirit or group mind which would permit us to speak of races, classes or ages in terms we use for individuals' (Gombrich, 1979:200).

Although he does not use the term, it is the sense of 'Zeitgeist' to which he objects.

If this 'collective spirit' is seen to be some mystical emanation which possesses and imbues a group, tribe or nation with a specific style then the objection must be supported. Yet, however subtle the difference, from an ecosystemic viewpoint it must be granted that a group of individuals involved in common enterprise generate, what the C18 'philosophe' D'Alembert (Norberg-Schulz, 1979:7) termed the 'esprit de système', and any communal enterprises will be tacitly guided by and expressive of this communal spirit. This is the same as Kuhn's (1970) 'paradigm' which he has coined for the milieu wherein the scientific enterprise is conducted, but as a term, more expressive.

Gombrich (1979:213) is supportive of Kimball's interpretation of 'The Creation of the Rococo' where Gombrich observes that 'style in art, like style in language, is rather a matter of weighted preference'. It is however unfortunate that the Rococo style is

chosen as model since it is the swansong of the Western classical tradition. The stylist was presented with a multiplying number of choices. The post-Reformation world was in flux and the paradigm in change. Style revolution was in the offing and style-diversity the order of the day.

Which brings us to his observation, that style decadence is the end result of the concept of 'logical development'. 'Styles come to an end where [the conflicting demands of technique and ornament] have, run their course and can go no further' (Gombrich, 1979:209). As an alternative to style as a sense of 'spirit of the age' he offers the 'concrete [sic] notion of "movements"':

'Movements may be started by individuals who find followers among whom a strong sense of identity develops. Sometimes they want to distinguish themselves from others in their dress, deportment and preferences. Sometimes they may even adopt style as their badge' (Gombrich, 1979:215).

But how does this solve the problem of a shared spirit? Is this sense of shared style more acceptable since not defined by national boundaries? All that can be deduced from this is that style changes are wrought by individuals but that they are quickly appropriated by all who identify with that individual.

3.13 THE OBJECTION TO HISTORICISM

Ackerman (1962:231) objects to a determinist view of style where the historical process is seen as one of destiny fulfilment:

'Twentieth - century scholars do not grant a priority value to any phase of evolution, but a value-concept lurks in the shadows; if it is the destiny of styles to evolve as they did, then

those works of art which promoted that evolution are destiny - fulfilling and those which did not are destined to stagnate. The implication that the former are superior cannot be avoided'

This objection is directed against the historicist viewpoint which requires a sense of predestination. Popper (1969:V-VI) in his introduction to the second edition of 'The poverty of historicism' states his argument against such a view of history succinctly:

- '(1) The course of human history is strongly influenced by the growth of human knowledge. (The truth of this premise must be admitted even by those who see in our ideas, including our scientific ideas, merely the by-products of material developments of some kind or other).
- (2) We cannot predict, by rational or scientific methods, the future growth of our scientific knowledge.
- (3) We cannot, therefore, predict the future course of human history.
- (4) This means that we must reject the possibility of a theoretical social science that would correspond to theoretical physics. There can be no scientific theory of historical development serving as a basis for historical prediction.
- (5) The fundamental aim of historicist methods ... is therefore misconceived; and historicism collapses.'

Here he has aptly and adequately dealt with the flaws of this sense of history and the argument will not be pursued. Predestination is a component of a belief system and as such cannot be gainsaid or counter-argued. What should be observed is that from an ecosystemic viewpoint Bateson's (1980:245) sense of the 'stochastic process' is more useful:

'Stochastic. (Greek, stochazein, to shoot with a

bow at a target; that is, to scatter events in a partially random manner, some of which achieve a preferred outcome). If a sequence of events combines a random component with a selective process so that only certain outcomes of the random are allowed to endure, that sequence is said to be stochastic'.

Thus a range of possibilities is opened by directed change but in the process of change other possibilities at the level at which the change occurred are forever precluded. Riedl (1978) has demonstrated this in 'The order of living organisms' where he shows that evolution has precluded the possibility of certain of the bestiaries of which the mythologists and zoographers are so fond. We cannot have mermaids, cherubims, griffins or seraphims since there is a genetic exclusion of the combination of the somatic features required through the stochastic process. The same can be assumed of history. Each historical event precludes the occurrence of certain historical possibilities. Events are not destiny fulfilling but destiny selecting.

3.14 STYLE CHANGES

Ackerman (1962) is chiefly concerned with the idea of style change. He, like Gombrich, is also concerned with what he terms, the 'biological metaphor' (Ackerman, 1962:230) and particularly the determinist sense of 'preordained pattern of "evolution"'. 'Biological evolution' should not however be considered as a metaphor of 'cultural evolution'. In the hierarchy of systems it follows its own pattern of change by techniques different from those of biological evolution. The agencies of change too are different - 'individuals' rather than 'gametes', and the system less linearly time-bound. Artefacts from the past can return the memetic content it bears.

Ackerman states that

'given our background in the dialectic of German art history, it is necessary to emphasise that a nation, a religion, a Zeitgeist is likely ... to resist rather than to promote [his italics] change in style' (Ackerman, 1962:232).

Zeitgeist becomes an amorphous concept unless seen as a component of that from whence it manifests - 'society' - just as 'mind' is allied to 'brain'. Hence the preference for the previously mentioned concept 'esprit de système'.

The idea that 'the 'spirit of the system,' once established, will have an inertia to change and offers no problems. Mature cultures will be conservative and static by nature but this inertia is tempered by the destiny selective character which that culture acquires.

Ackerman (1962:233) then states that:

'The problem is to discover an explanation of recurrent patterns that avoids on one hand the tyranny of external historical forces or laws, and on the other hand the anarchy of mere chance'.

'my primary aim is to explain change in style as the manifestation of the imagination of individual artists than that of historical forces that guide the action of men and nations'.

There are however no 'historical forces' to 'guide actions'. There are also not 'external historical laws'. To speak of the 'anarchy of mere chance' would suppose a chaos of individuals without any social sense.

Yet his observation that it is the individual who precipitates style change can be supported. Systems

are in a state of dynamic equilibrium. If the homeostatic aspects - the checks and balances which act through feedback - are disturbed then the system will be in flux. This usually occurs when the size of that system exceeds the extent of the channels of communication. In societies this results in paradigm change or shift and for the period of system disturbance the individual is given more freedom for experimentation.

If style change is viewed ecosystemically then the role of the individual is acknowledged but not viewed as of constant importance at all times. In times of paradigm crisis the individual is nurtured and individual freedom cherished and his style will not be that of the community. With the stylistic hiatus which results in a period of paradigm crisis or change there is an opportunity for the individual genius to arise and fill the vacuum. Hence personalities such as Goya in art and Beethoven in music are given free range for their personal genius and from their style experimentations the phoenix might rise.

3.15 THE CANONISING OF ICONIC STYLE

Iconic styling, since it exists in the realm of abstract meaning, requires the interpretive act to be understood and redeployed. Bonta (1979:142) has studied the case of the Barcelona Pavilion (1929) of Mies van der Rohe as an example for critical attention. He has identified two phases of style interpretation - pre-canonical, and canonical.

'Pre-canonical interpretations are the most creative ones. In facing a new form for the first time (or an old form from a new angle, as if it were new) the interpreter is left on his own to find its meaning. Constructing the interpretation is a challenge to his intuition, sensitivity and

imagination'.

By contrast canons:

'[have] meaning ... attached to form by social consensus. Individuals learn the meaning, rather than construct or reconstruct it for themselves. As the canon becomes fixed, the initial insights that led to the association of form, and meaning may be completely lost' (Bonta, 1979:142-3).

This loss of ideas is part of the process of canonisation which Bonta (1979:145) ascribes to 'filtering' rather than 'growth':

'The canonical interpretation is a cumulative result of many previous responses, distilled by repetition and reduced to bare essentials.'

The question then is why certain aspects of interpretation are lost in the process of canon formation? The simple answer is so as to eliminate contradictory and conflicting aspects of pre-canonical interpretations and present the canon as having an internal consistency. With time, ideas which have been canonised in style can then be represented in a reduced fashion.

'As individuals learn to recognise the form as a canon, they will be able to identify it even when the form becomes increasingly more schematic, simplified, or distorted' (Bonta, 1979:143).

From the above it can be seen that style canonisation is a selective and reductive process. Although requiring the creative input of interpretations by individuals these are eventually synthesised into an internally consistent whole and aspects of conflict and contradiction are omitted. This is a necessary requirement if individual 'style' is to achieve currency in the cultural domain.

3.16 THE NAMING OF STYLES

'Maybe it is only post factum, by a process of hindsight, that styles can come to express the spirit of an age - an age which has acquired the quality of a myth' (Gombrich, 1979:216).

It should not surprise us that the recognition of stylistic unity and sense of a spirit of an age is post factum, for a community is unable to articulate or bring to meta-cognition the tacit and subliminal directive which dictate their 'doing'.

It is also of interest that the naming of a period, particularly that of the most recent past, is usually pejorative. Hence to be "Gothic" in the Renaissance was to be barbaric. It was only the C19 stylists who could use the term neutrally or, as was the case, with appreciation. Banister Fletcher (Palmer, 1975) did not allow for the 'Baroque' in his 'Comparative history of architecture' since the term was only then gaining currency, and then with a sense of derision. Burckhardt in 1855 initially used the term to contrast with the Renaissance 'a wild, and barbarous art known as "baroque", the degenerate bastard of the Renaissance' (Bazir, 1968:15). We see the same attitude emerging to the sense of 'Modern':

Now 'modern' is a curious term - it can be used to degrade as well as (or more often than) to elevate. It can mean decadent, degenerate, nihilistic, abysmal, at one end ...' (Bellow, 1992:23).

There is no doubt that the word 'Modern' will be later employed as a neutral term for the period and its initial sense of 'contemporary' will fade.

We should not feel alarmed that a designation of a style term in some way negates the realities of the

communal enterprise of a time simply because it is psychologically useful to telescope the diverse enterprises of a period into a term and supplant all the issues of debate and discovery by a sense of 'spirit'. Were this not possible we would not be human and like the rest of the animal kingdom would be living in the eternal present.

3.17 THE INTERPRETATIVE HIERARCHY

It was a Dane, Christian Thomson (1788-1865) who, by a creative accident that often leads to profound discovery, categorised the collection in his charge in terms of materials employed, rather than usage of the artefact (Boorstin, 1983). This arrangement of artefactual material led to an understanding of the stratification of cultural evolution. Much as the stratification of fossil-bearing material is indicative of the place of the organism in the evolutionary chain so too the stratification of artefactual material implies a hierarchy of cultural evolution.

A hierarchy of interpretations can be distinguished within the temporal strata of cultures. The artefactual material, the artefactual type, and artefactual style all need to be ascertained. A cognitive hierarchy of interpretation has been given by Panofsky (1962) for investigating artwork as artefact. Within the interpretative hierarchy each act of interpretation is directed at a particular object type and accessed through a different historical system.

Pre-iconographic interpretation is descriptive and has natural and factual matter as objects which are accessed through analysis of their

stylistic characteristics.

- Iconographic interpretation is associative, has conventional subject matter as object and is accessed through an historical understanding of types.
- Iconological interpretation is speculative, has the symbolic content as object and is accessed through a familiarity and empathy with the nature of the human mind which produced the artefact.

This interpretative hierarchy could be broadened to the full spectrum of artefacts throughout the disciplines. Hence the architectural historian too is ultimately obliged to interpret those artefacts of particular concern, for example buildings, elements and plans iconologically.

3.18 AN ECOSYSTEMIC SENSE OF 'STYLE'

In an ecosystemic approach 'style' characterises a particular culture but need not be construed as a means of passing judgement. It needs to be seen as functioning systemically at the cultural level. If 'style' is accepted as the way for cultural communication and interaction of communities which have common experience and endeavour, then it can only be evaluated in terms of the success in achieving this end.

Doubts which have a place within the causal and deterministic world-view of the Mechanistic paradigm where the dogma of 'progress' supposes that any event or process which contributes to that 'progress' is laudable and superior to all those which did not, are

untenable in Ecosystemic thought. Such arguments may even hold where the forfeit of biological 'unfitness' is extinction. Cultural evolution has advantage over biological evolution in that ideas can be given currency and tested without sacrificing the bearer of the ideas, although the martyrdom of heretics proves the rule! But then again ideas persist long after the flesh is vanquished.

Any argument which attempts to deny the existence of style is not only denying culture the medium for its being but also its persistence. With time comes tradition, refinement, sophistication and variation. Through cultural depth arises an iconology, where prototypes gain cultural significance and acquire cultural 'meaning'. Styling can therefore be exploited and diversified for cultural enrichment.

The synchronic and diachronic purposes of style are different. The stylist is communicating in his time and with his culture - that is synchronically. Yet through the persistence of the artefact the stylist is also communicating and revealing something of his culture through time, that is diachronically. This is the equivalent of the interactive (synchronic) and traditive (diachronic) characteristic of open systems.

Styling is thus a complex inter-action of the components of place and time. The variation of styling through the exploitation of the diversity of available cultural resources should hypothetically lead to an infinite variety of styles. What is surprising is that there is a consistency in the stylistic response at a particular place during a specific time. This suggests cultural conservatism and continuity of tradition rather than revolutionary change.

3.19 SUMMARY

Certain cultural activities of a community are at a pre-iconic level and are not exploited for stylistic experimentation. Such aspects will persist and become canonical and not be consciously recognisable as 'style' to the members of a community. Such pre-iconic, or isochrestic style is tacitly agreed to and further style variation thus limited.

The opportunities for enrichment of styling are a function of time. The degree to which each level of styling is exploited and the degree to which the manner of doing becomes canonical in time is indicative of evolving cultural stability and diversity. The degree of abstraction in styling is indicative of cultural depth and maturity. This should all be able to be 'read' in the styling of the artefact.

Since styles always emerge from traditive elements and the future determined by the destiny selection of the past the logic of style development has to be established ex post facto.

If the cultural system of which the style is part changes then the style will change. If change encourages the historians to coin a new style term then it is indicative of a changed system of culture with another set of tacit guides. Through style interpretation these can be made overt by the historian. The use of a synoptic terminology for style designation helps to capture the essence of the manner and spirit of such doing.

Past cultures can be accessed hierarchically through analysis of artefact from pre-iconographic, through

iconographic up to iconological interpretation. As such, artefacts retain potency. Ideas can be reformulated and again given currency. The artefact thus has ecosystemic agency.

3.20 CONCLUSION

The second subproblem was "to determine a sense of style within the Ecosystemic Paradigm".

The second hypothesis was that, through styling, artefacts are encoded with cultural significance.

Styling has not only been shown as a means of cultural encoding but the employment of style has been shown to be hierarchical and dependent on the cultural maturity of the community with which it is associated. Ecosystemically styling has cultural significance both synchronically or interactively as a means of cultural recursiveness and diachronically or traditively as a means of cultural autopoiesis. The hypothesis is supported but seems to be restricted and will therefore be expanded into the assertion that 'artefacts have stratified encoding of cultural significance through styling'.

Opp. 43

Chronological sequence of significant
historical plans to the same scale.

CHAPTER 4
THE ICONOGRAPHY OF 'THE PLAN'

4.1 SUBPROBLEM 3

The third subproblem is to determine the relationship of 'style' to 'plan'.

4.2 HYPOTHESIS 3

The third hypothesis is that the plan has style.

4.3 OUTLINE OF CHAPTER 4

In Chapter 4 the rôle of the plan in the discipline will be outlined, a contemporary definition presented, and the nature of the plan as artefact be determined by musical analogy. The plan in history, from antiquity to the present and the future as artefactual type, will be outlined.

Opp. 44

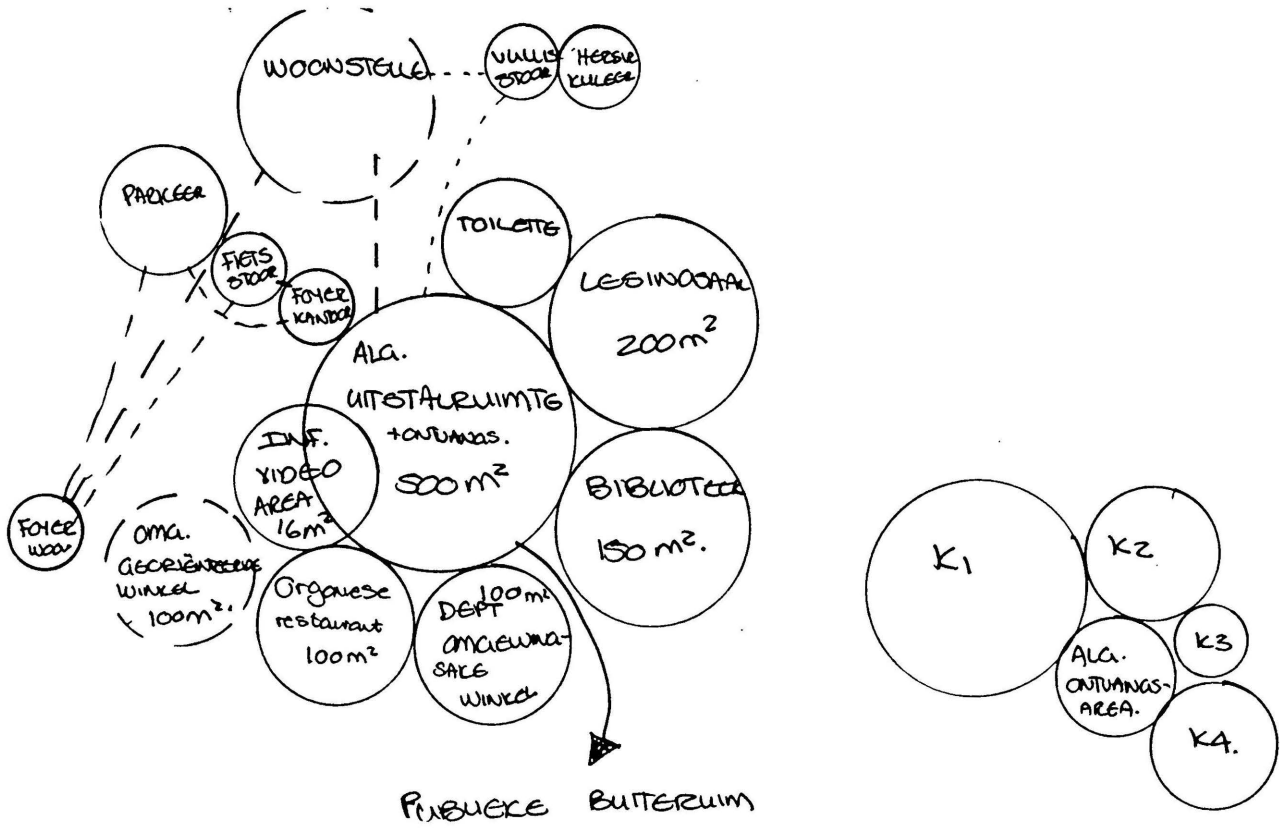
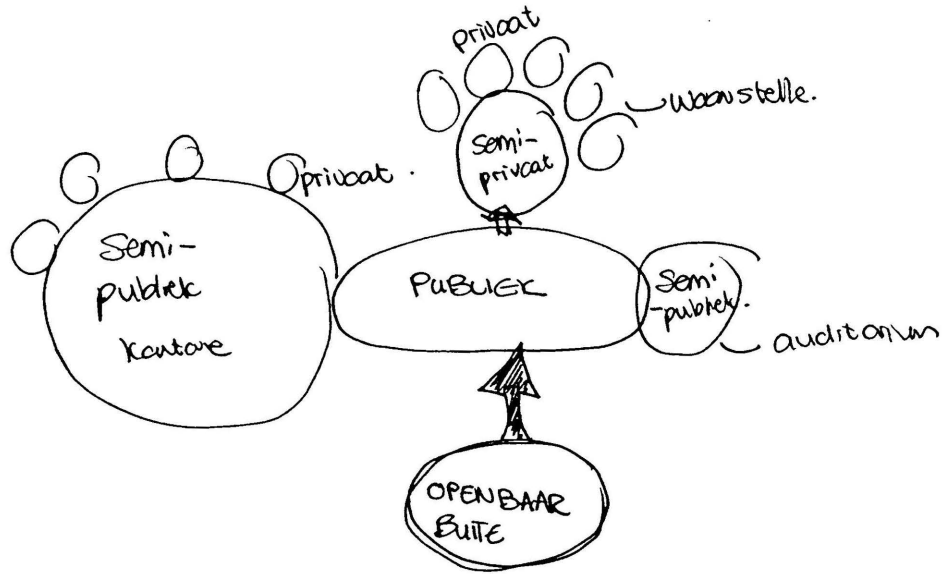

FIGURE 4.2 Plan development from 'bubble-diagram'.

4.4 INTRODUCTION

The building as artefact is a complex amalgam of the talents of various disciplines. Yet even though the artist might have the surfaces, the sculptor the forms and the technician the structures, the plan remains the preserve of the architect. In the discipline of architecture the plan is the artefact for short-hand communication. Each plan encountered adds to the array of gestalt images which the architect has in his mental memory-bank and broadens the scope of his response as designer.

The plan is not the planning. This is evidenced by the fact that the function of buildings, and hence the planning might change, but the plan remains recognizable. Also compelling is the idea that, while every architect might be given the same brief with the same planning requirements, the plan of each will be different. A bubble-diagram satisfies the requirements of planning but presents no plan (figure 4.2). In having solved the planning, architects have always felt free to offer the plan without annotation as product, thus going beyond the functional relationship of the areas planned.

In architecture the plan, as an image of the essence of architectural intent, is independent of its built form. As a gestalt image it is the schema which is the currency of cultural exchange.

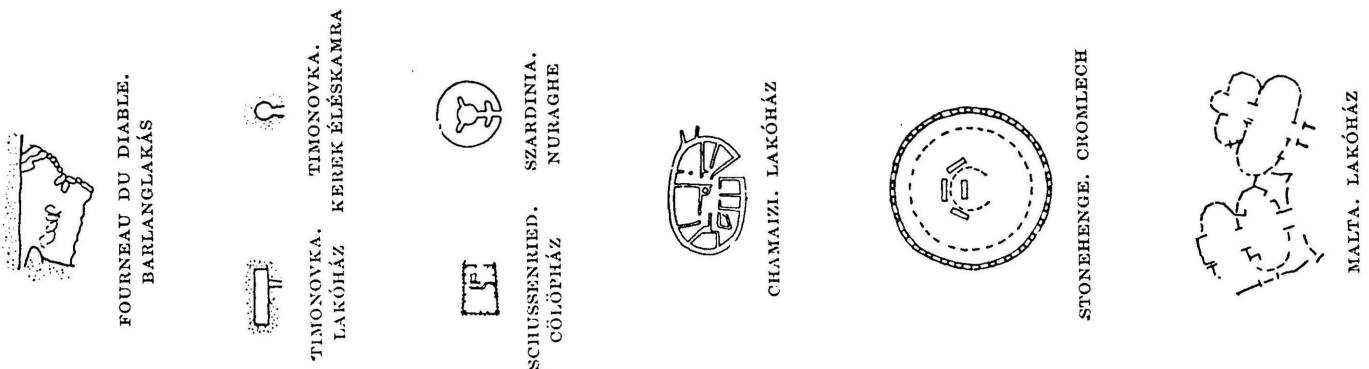

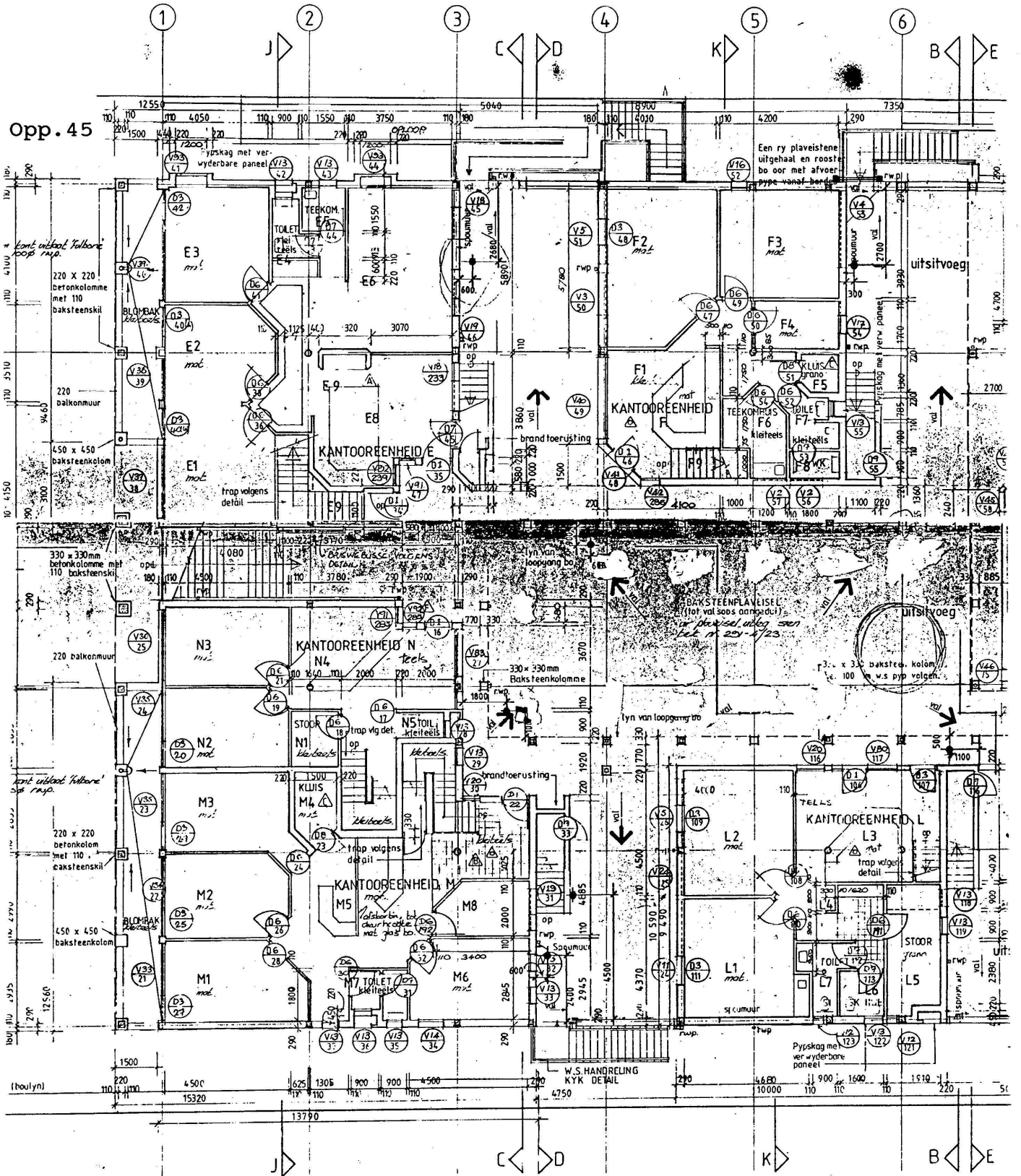

FIGURE 4.3

Conventional plan representations - ground floor plan, Gildehuis, Nieuw Muckleneuk, Pretoria (compare figure 5.4).

4.5 THE PLAN BY DEFINITION

'How to think about the plan?', that is the question.

The straightforward understanding of 'the plan' is that it is

'basically a horizontal cut or section through space. Things which are cut such as walls or columns are outlined in a heavy line weight. Things which can be seen below the place where the plan was cut are indicated in a lighter line weight. Things ... which cannot be seen because they are above the level of the cut, can be shown in with a heavy dashed line if required' (Laseau, 1980:44) (figure 4.3).

This might be enough for a contemporary interpretation of the plan, but is it adequate for understanding all plans throughout history? Should all plans not look the same, and if not can we speak of plan style?

4.6 THE MUSICAL ANALOGY

Let us look by way of analogy to another creative discipline, that of music. The composer, like the architect, is also required to provide instructions for the execution of the work, specifically by means of the score. When looking at a musical score, especially if not trained in the reading of musical notation, it is still apparent that the notation has a 'style' and that this 'style' of pattern-making allies it to the period of its composition, and if

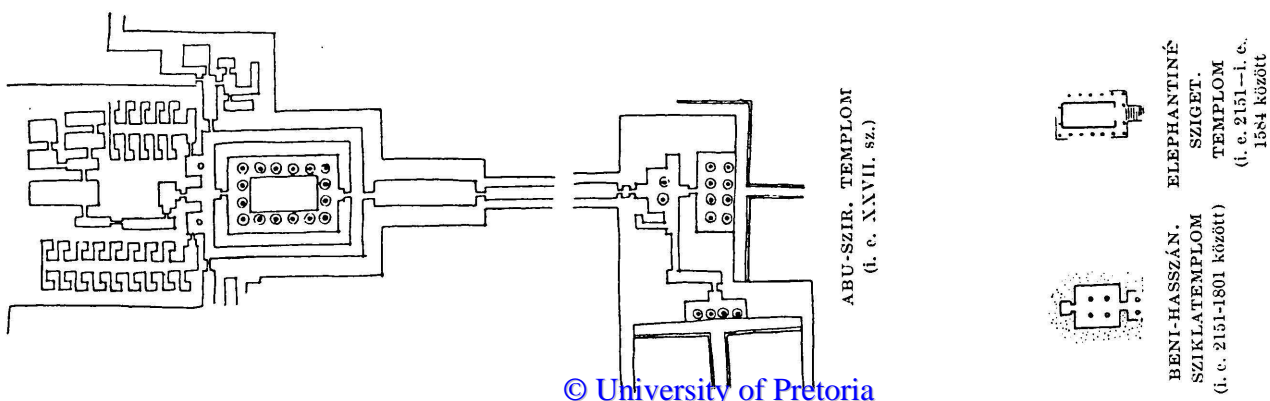

Opp. 46



FIGURE 4.4

The image shows a printed musical score for the Christmas Oratorio. It is a performing edition, featuring a full orchestral and vocal arrangement. The score is divided into two systems. The left system includes staves for Tromba I in D, Tromba II in D, Tromba III in D, Timpani, Flauto trav. II, Oboe I, Oboe II, Violino I, Violino II, Viola, Fagotto, and Organo e Continuo. The right system includes staves for Violoncelli, Tutti, and other instruments. The score is written in a clear, printed font, and includes various musical notations such as notes, rests, and clefs.

FIGURE 4.5

No. 962

E.E. 4353

FIGURE 4.4 J S Bach - Autographed manuscript copy of the Christmas Oratorio.

FIGURE 4.5 Bach Christmas Oratorio - performing edition.

gazing upon an original manuscript, the particular composer. Even the mood of the music might be discerned, ponderous or agitated, in its graphic representation (figure 4.4).

The plan is as a musical score. Whereas the lines, bars and notes abstract the disposition of sound through time, the plan is the abstraction of the disposition of elements through space. The thought of architecture as frozen music is therefore not only appropriate to the analogy in the use of elements of pattern, rhythm, texture and suchlike, but also extends to the manner of abstract presentation and means of final execution.

Like a musical score it is the most entire artefact of the discipline revealing of the architect's intent. As the musical score allows a certain latitude of realisation by the interpreter, so the plan may be brought to built form in more than one way. 'The plan is the generator' (Le Corbusier, 1986:47) but not the determinator. Just as the musical score can be reproduced (figure 4.5) so too can the plan. Iconographically it is different to the original, but iconologically (assuming no error in transcription) the same. In this way the disciplines of music, architecture and literature differ from the purely visual arts.

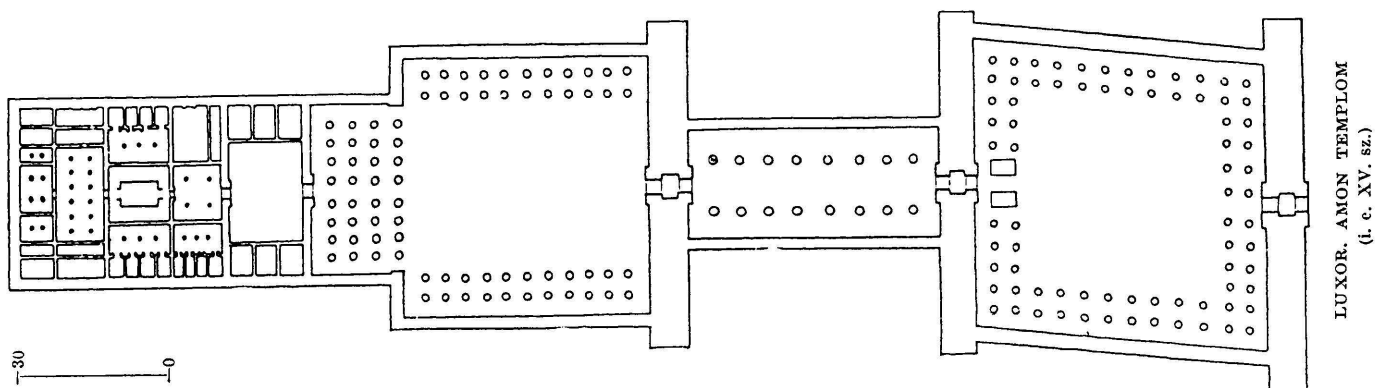

Opp. 47

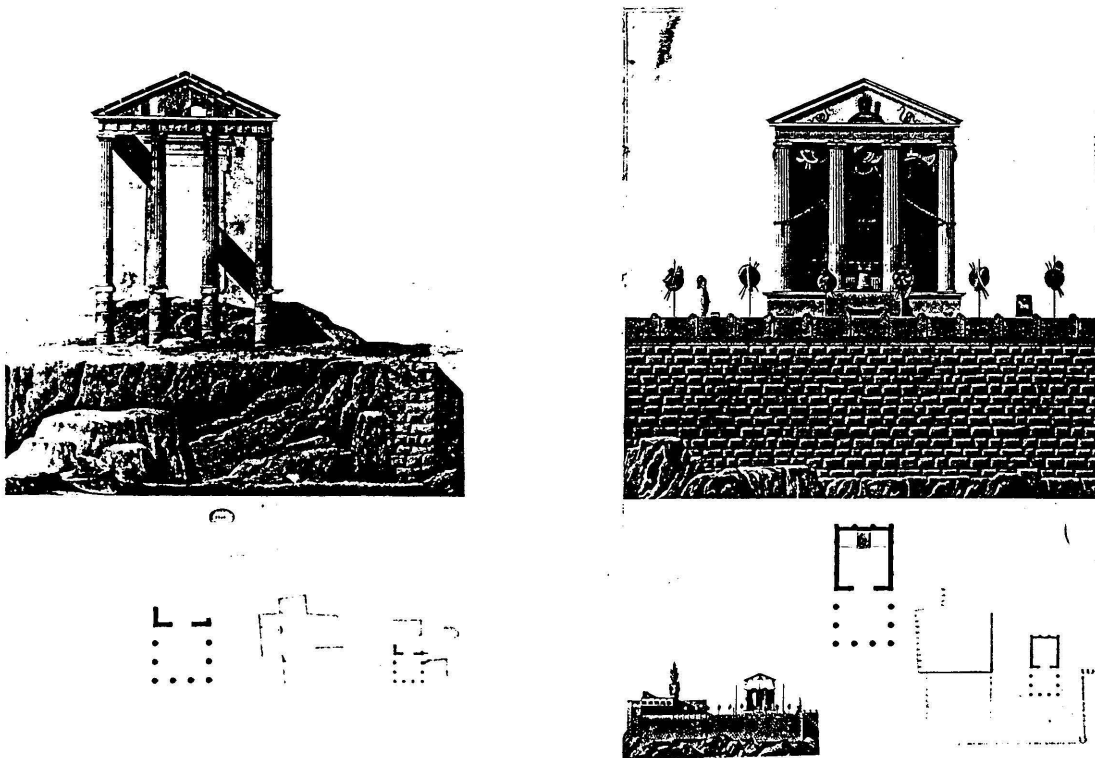

FIGURE 4.6

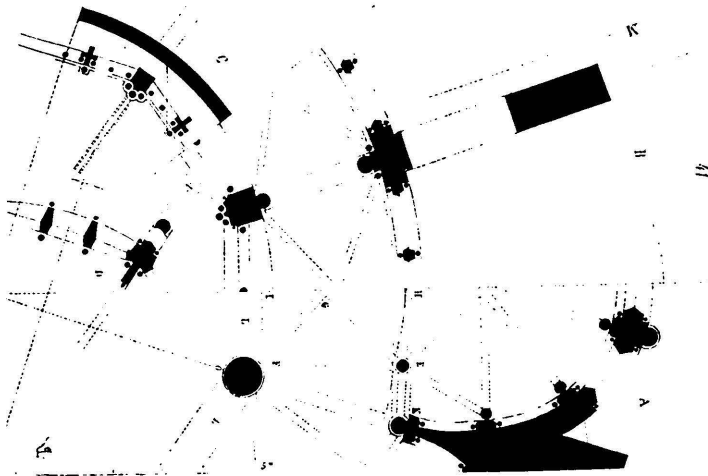

FIGURE 4.7

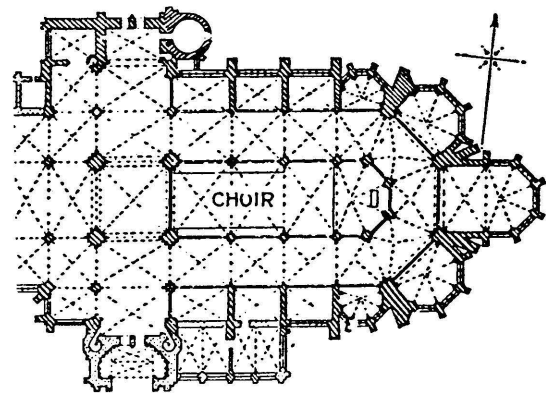

FIGURE 4.8

FIGURE 4.6 Beaux-Arts reconstructed plan from classical antiquity.

FIGURE 4.7 Plan drawings of apse at Notre-Dame de Chalons - E E Viollet-le-Duc.

FIGURE 4.8 Apse S. Oen, Rouen (1318 - 1515) as shown by Banister Fletcher.

4.7 THE ANACHRONIC PLAN

We must proceed cautiously. Not all plans come to us from their time. On the contrary, most plans which we have of historical structures are of relatively recent making. The Beaux Arts education brought to us many of those plans which are known from Classical times (figure 4.6). And here lies the rub. Any plan constructed after the event will carry the stamp of its time of making. For the plan is not a bland mark like a fingerprint. It is an abstraction. A plan conveys the information which its author wishes to communicate. If the author has a particular interest in groin vaults and flying buttresses then he will be sure to employ the necessary conventions in order to convey the information on plan (figures 4.7 & 4.8). For on plan there will not be vaults or buttresses, only clustered columns and piers. The configuration of vaulting can however be shown by the device of hatched lines, a convention which changes the reading of the plan from two to three dimensions and aids the stereometric visualisation thereof.

Artefacts from the past, through the pre-iconographic and iconographic interpretation of experts, have been categorised and such plans can therefore be chronologically arranged. What follows is a presentation of some of these in order to discover the evolution of the plan as artefact.

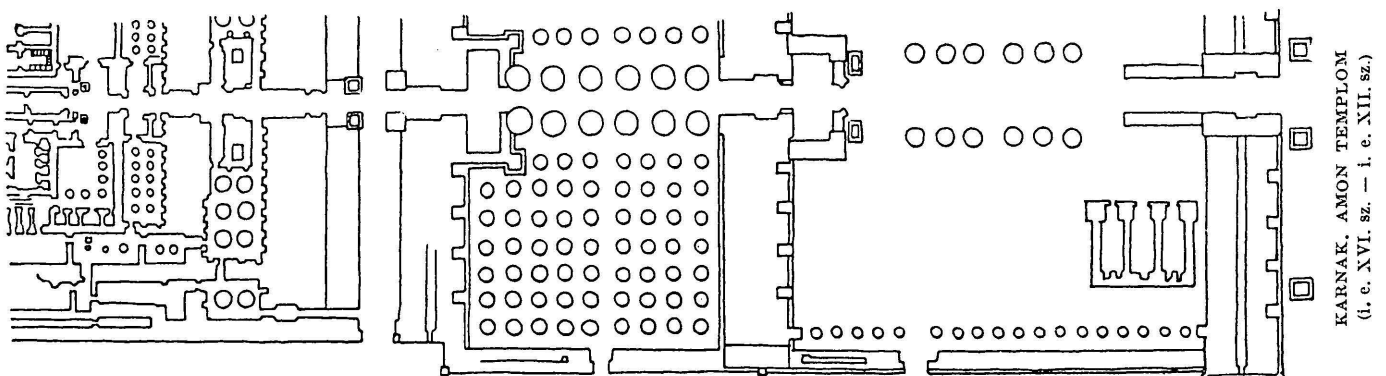

Opp. 48

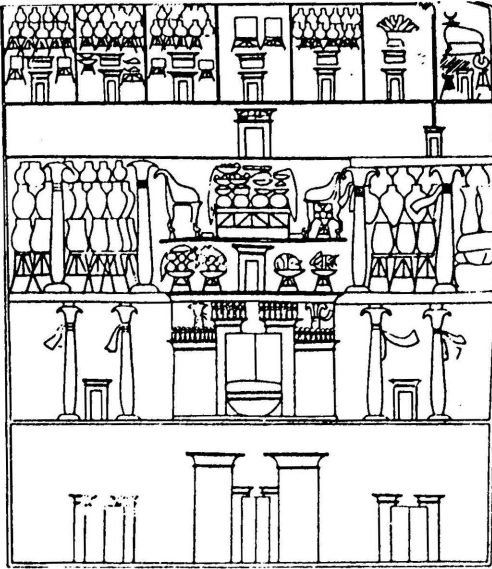

FIGURE 4.9



FIGURE 4.10

FIGURE 4.9 A painting depicting an Amarna palace from the tomb of Mery-Re, high priest of Aten; XVIII Dynasty.

FIGURE 4.10 Landscape architect's ink sketch plan for a grove fronting the temple at El-Dier el Bahari; XI Dynasty.

4.8 THE PLANS OF ANTIQUITY

The Egyptians, thanks to the nature of their culture and climate, have been generous in their legacy and we have displayed amongst their hieroglyphs, diagrams of the planning of buildings. Yet these would not pass as plans in our understanding of the word (figure 4.9).

What interests us in the Egyptian plan representation are the devices employed. Walls which cordon areas are shown in section. The position of doors are shown by their juxtaposition in elevation. Their positioning as central and symmetrical seems implicit. Functions or uses are shown by associated pictogrammes - gods and offerings - in the rooms. The purpose of the plan was not as a representation for the execution of the building but as vehicle for eternalising the activities associated with the deceased. We do however have evidence that the Egyptians were given to planmaking. A landscape design layout (figure 4.10) circa 2100 BC of ink on sandstone attests to this. It is a simple rectilinear grid giving only a geometry of layout and has not the sense of a horizontal section.

As for the Greeks, we are not even sure whether they were given to plan-making or not. Their plans emanated from the choice of order and would follow logically from the 'archi-tect' or chief builders' 'paradeigma' or modelling thereof.

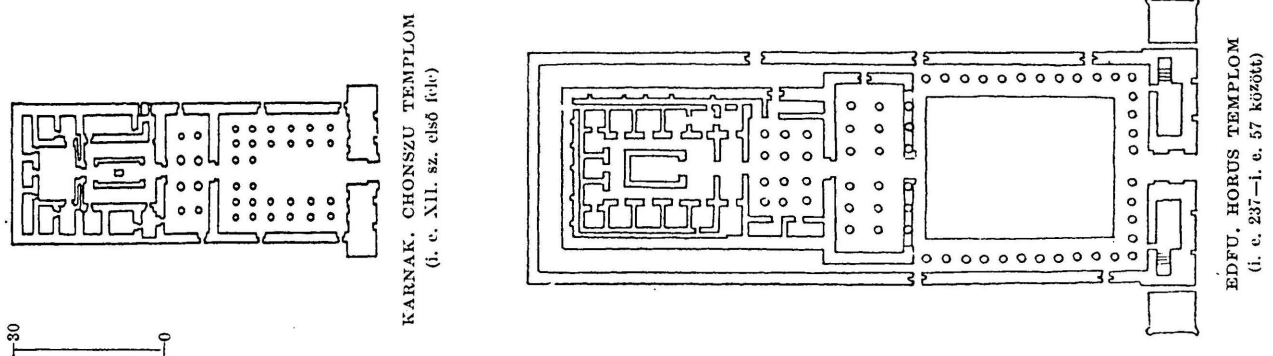

Opp. 49

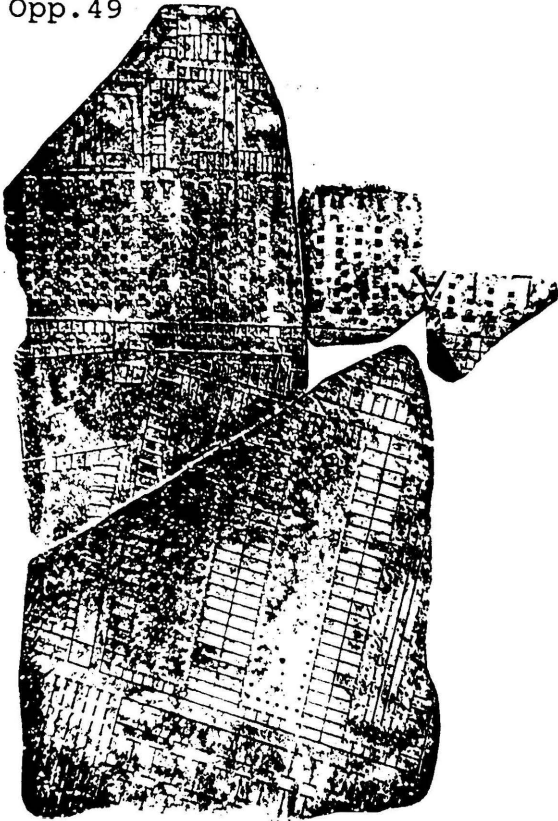

FIGURE 4.11

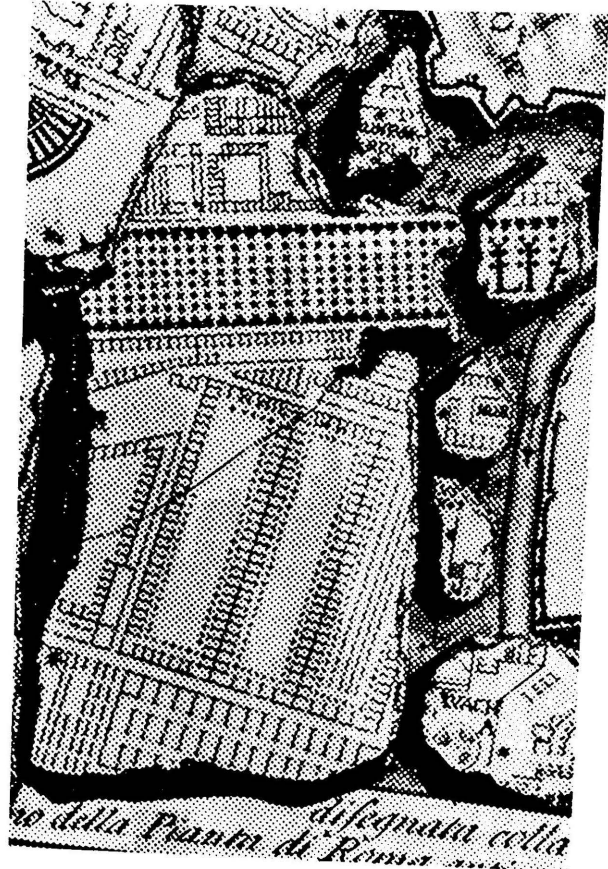

FIGURE 4.12

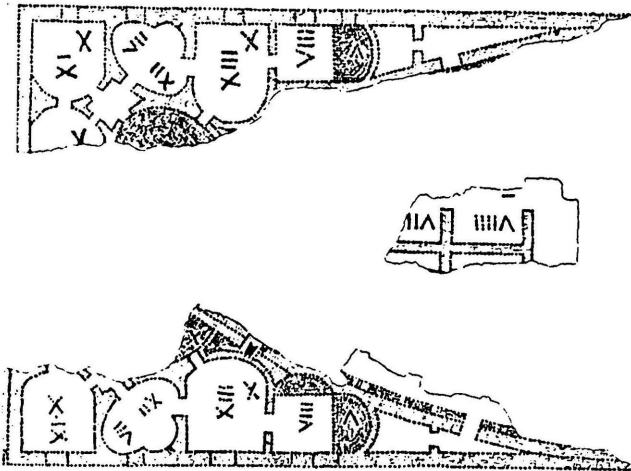

FIGURE 4.13

FIGURE 4.11 Marble fragment of the Urbis Romae.

FIGURE 4.12 Detail of Piranesi's map of Rome in his 'Antichita romane I'.

FIGURE 4.13 Fragment of Roman bath in mosaic.

There is no point in entering the debate as to whether the Greeks produced plans for their buildings. All that can be noted is that we have no evidence either way and that in our search for plan-style we can only assume Greek plan-style to be of the same geometrical nature as that of the Egyptians.

What evidence we have of Roman plan-making is also of a post factum type. The Forma Urbis Romae initiated by Septimus Severus as inventory of the built C2 Rome exists in fragments of engraved marble (figure 4.11). These so tantalised Piranesi that they were represented as decorative surround to one of his etchings (figure 4.12). Vitruvius enlightens us as to the manner of Roman planning but we have no artefactual representation by which to judge or understand their style.

'Drawing is employed in representing the forms of his [the architect's] designs. Geometry affords much aid to the architect : to it he owes the use of the right line and circle, the level and the square; whereby his delineations of buildings on plane surfaces are greatly facilitated' (Vitruvius, 1874:4).

A fragment of a mosaic plan (figure 4.13) dimensioned in Roman numerals may well have been copied from an architects drawing (MacDonald in Kostof, 1977:30). It is in the 'baroque' manner of the classical tradition, thus post-Vitruvian and the complexity of the plan suggests that a drawing would be necessary to execute

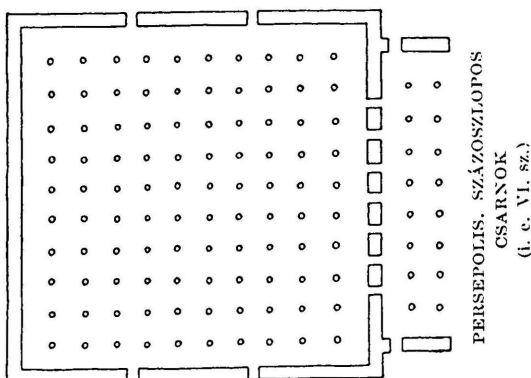

PERSEPOLIS. SZÁZSZILOPOS
 CSARNOK
 (i. e. VI. sz.)

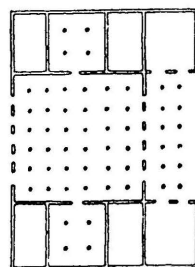

PERSEPOLIS. FOGADÓCSARNOK
 (i. e. VI. sz.—V. sz. eleje)

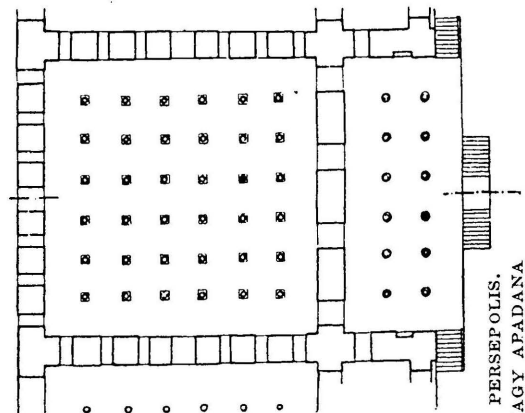

PERSEPOLIS.
 NAGY APADANA
 (i. e. VI. sz.—V. sz.)

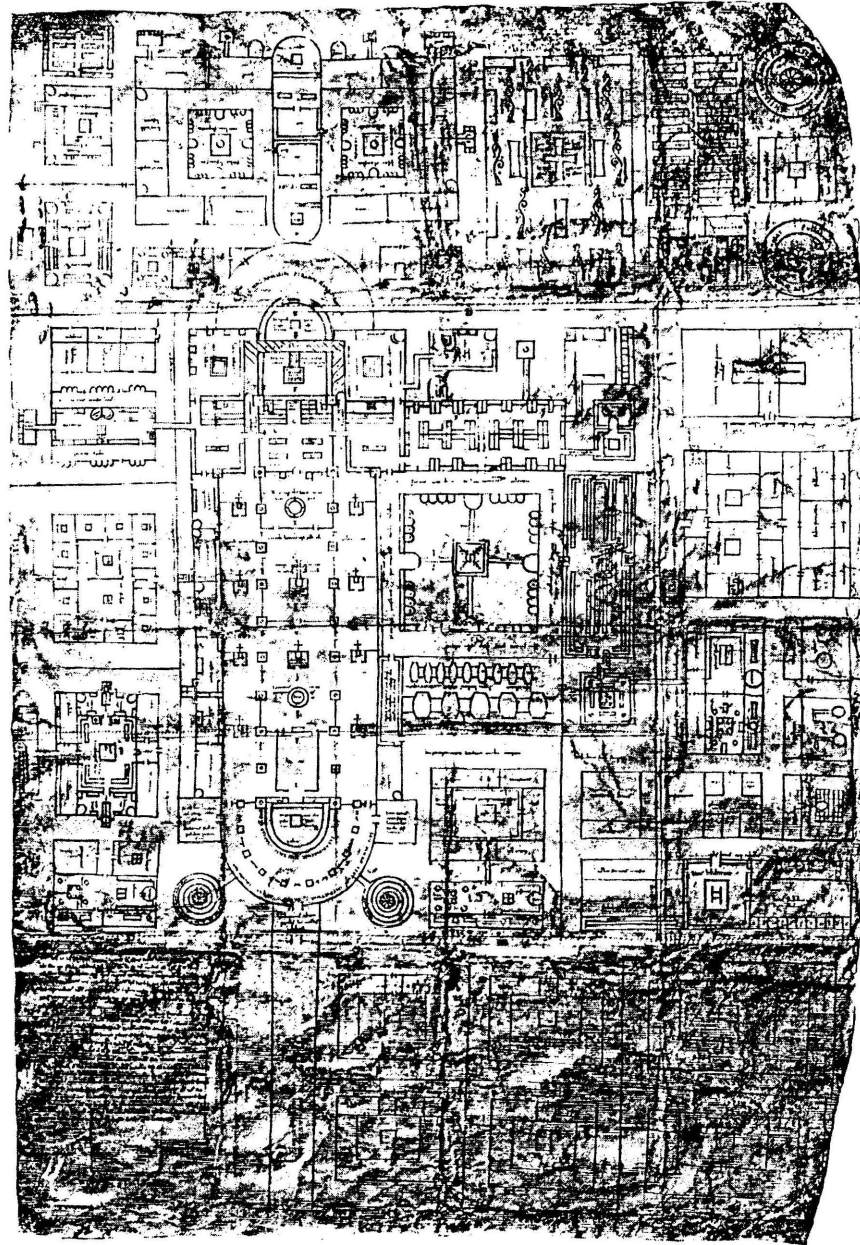

FIGURE 4.14 Monastery plan of St Gall.

the building. That this style of buildings was in fact drawn can be deduced from the C11 condensed text of Dio Cassius:

'Once when Trajan was consulting him [Apollodorus] on some point about buildings he had said to Hadrian, who had interrupted with some remark: "Be off, and draw your pumpkins ..."' (Mac Donald in Kostof, 1977:48).

Those 'pumpkins' are most probably the domes of buildings associated with Hadrian and he was therefore involved in the enterprise of their draughting at the time.

4.9 THE MEDIEVAL PLAN

We leap in time from the fall of the Roman Empire to the rise of the Carolingian Empire to discover our next plan artefact, the renowned layout of the ideal monastery of St Gall (figure 4.14). It is a plan diagram depicting the configuration of the forty buildings arranged in a squared grid about the church, the only building on plan which depicts some structural substance. The planning derives from the process of continuous halving to create modules which gives the plan the character of additive regularity. It is not an architect's original drawing since it lacks the characteristic auxiliary lines or pierced reference points, but a copy prepared for Abbot Gozbert of St Gall by a Superior to apprise him of official policy enunciated at the palace of Aachen in 816-7 (Kostof, 1977:71-3).

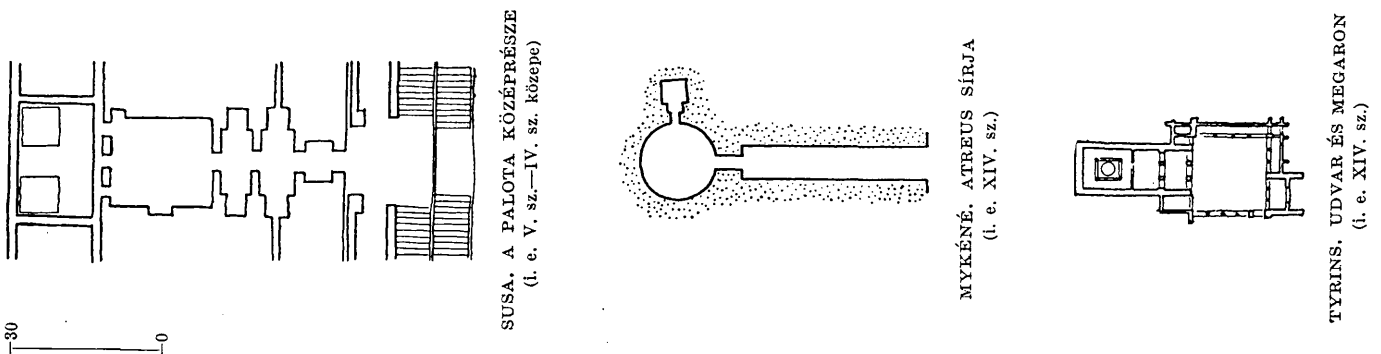

Opp. 51

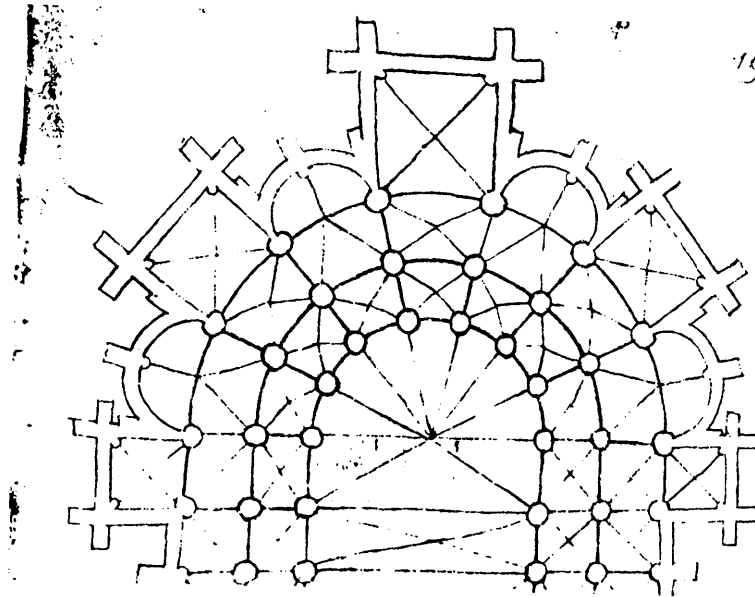

FIGURE 4.15

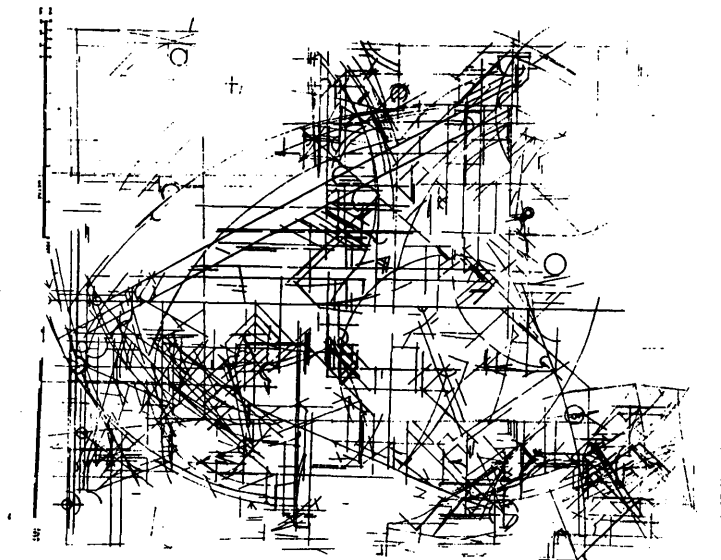

FIGURE 4.16

FIGURE 4.15 Detail from note book of Villard de Honnecourt (C13).

FIGURE 4.16 Drawing by J H Harvey of the tracing floor of Wells Cathedral.

Again we move another half millenium in time and enough has been built for the architect to journey through Europe and set up pattern books or exemplars of works which have taken either his or his patron's fancy. Such is the nature of the treasured C13 album of Villard de Honnecourt (figure 4.15). These are also post factum representations which would influence the geometrics carried in the 'minds-eye' of the architect. Much of the drawing, its geometry steeped in the mysticism of Pythagorean numerology, was constructed full-scale on site as can be discovered in the tracings of the floor of Wells Cathedral (figure 4.16). This geometry is what is promised by Villard de Honnecourt in his note of Plate II

'... you will find therein the art of drawing, the elements being such as the discipline of geometry required and teaches' (Kostof,1977:89).

4.10 FROM THE RENAISSANCE TO THE PRESENT

The production of pattern books, particularly as deriving from Classical precedent as was practised in the Renaissance, the development of etching as technique, perspective as pictorial representation and the printing press as means for broad and rapid dissemination, all have had a profound influence on the importance of the plan image.

The illustrating of Vitruvius through personal

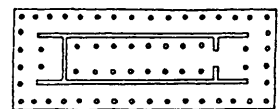
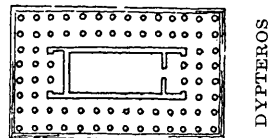
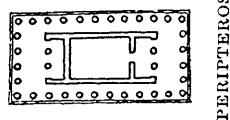
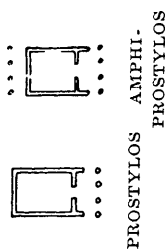
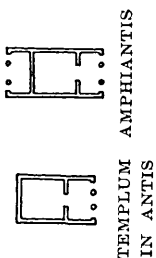
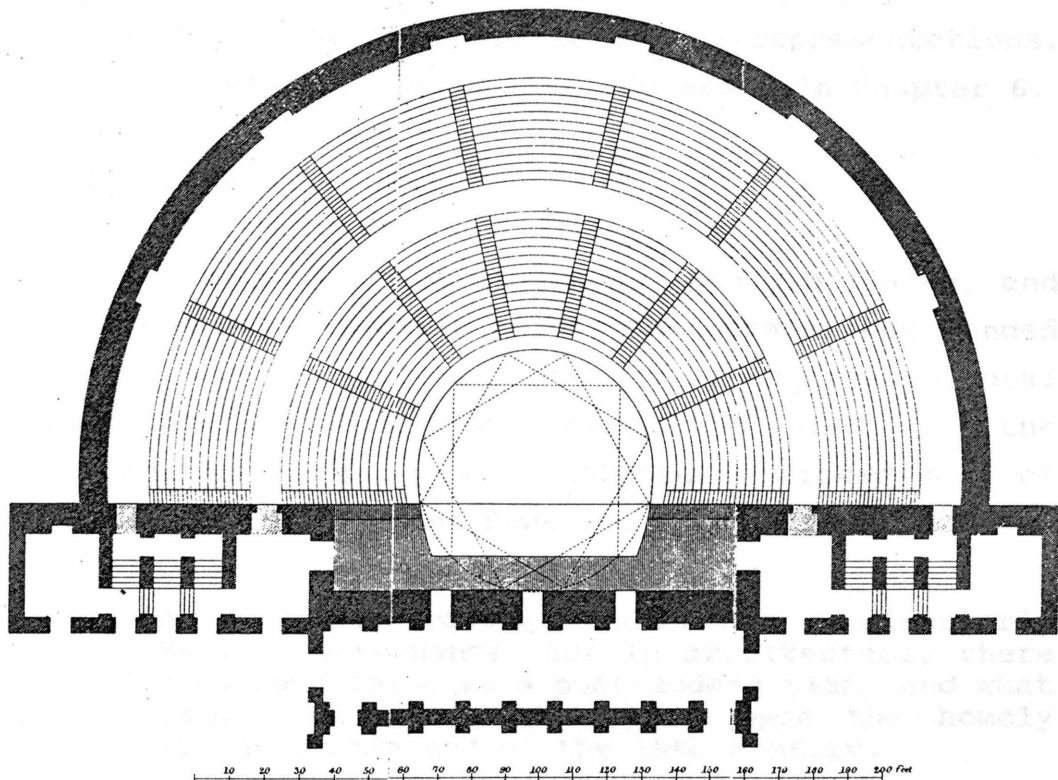

Plate 13.



London: Lockwood & Co., 7 Stationers Hall Court, Ludgate Hill.

FIGURE 4.17

'PLATE XIII Plan of the Theatre of Herodes Atticus, excavated on the side of the Acropolis at Athens. It corresponds in some respects with the directions given for the plan of the Greek Theatre in Book V. Chapter VIII'.

contemporary example became an enterprise of the learned and the practice continued until the demise of drawn illustrations in the C19 (figure 4.17). Imagery derived from the reconstruction of the Classic examples through description or later from measured ruins gave rise to the stylistic notion of Neo-classicism. Had Palladio not published his Quattro Libri the Grand Tourist would not have so readily imported Palladianism into the Whiggish England of the C18. It would be difficult to deny that the plan image contributed just as readily to the propagation of style as any of the other pictorial representations. This subject will be further addressed in Chapter 6.

4.11 THE CONTEMPORARY PLAN

The introduction of photography into publishing, and particularly the cheap colour photograph, has tended to suppress the use of plan imagery in architectural publication. This has been supplanted by the propagation of the photogenic facadism of postmodernism, a trend bewailed in a recent text:

'As a label, post-modernism has a singularly American provenance. But in architecture, there is no such thing as a post-modern plan, and what passes for such work relies upon the homely clichés of the end of the 19th century.

The plan of a building, therefore, is the most accurate measure we have of changes in architectural thought since the Beaux Arts.

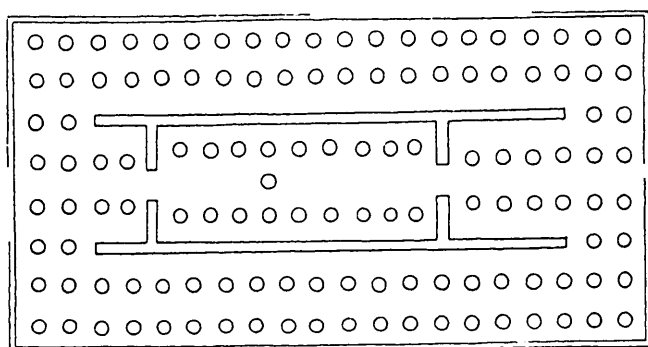

EPHESOS. ARTEMIS TEMPILOM
(i. e. IV. sz.)

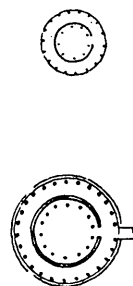

EPIDAUROS.
THOLOS
(i. e. IV. sz.)

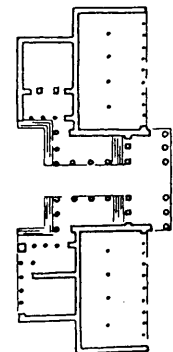

ATHÉN. PROPYLAIÁK
(eredeti szimmetrikus terv)
(i. e. V. sz.)

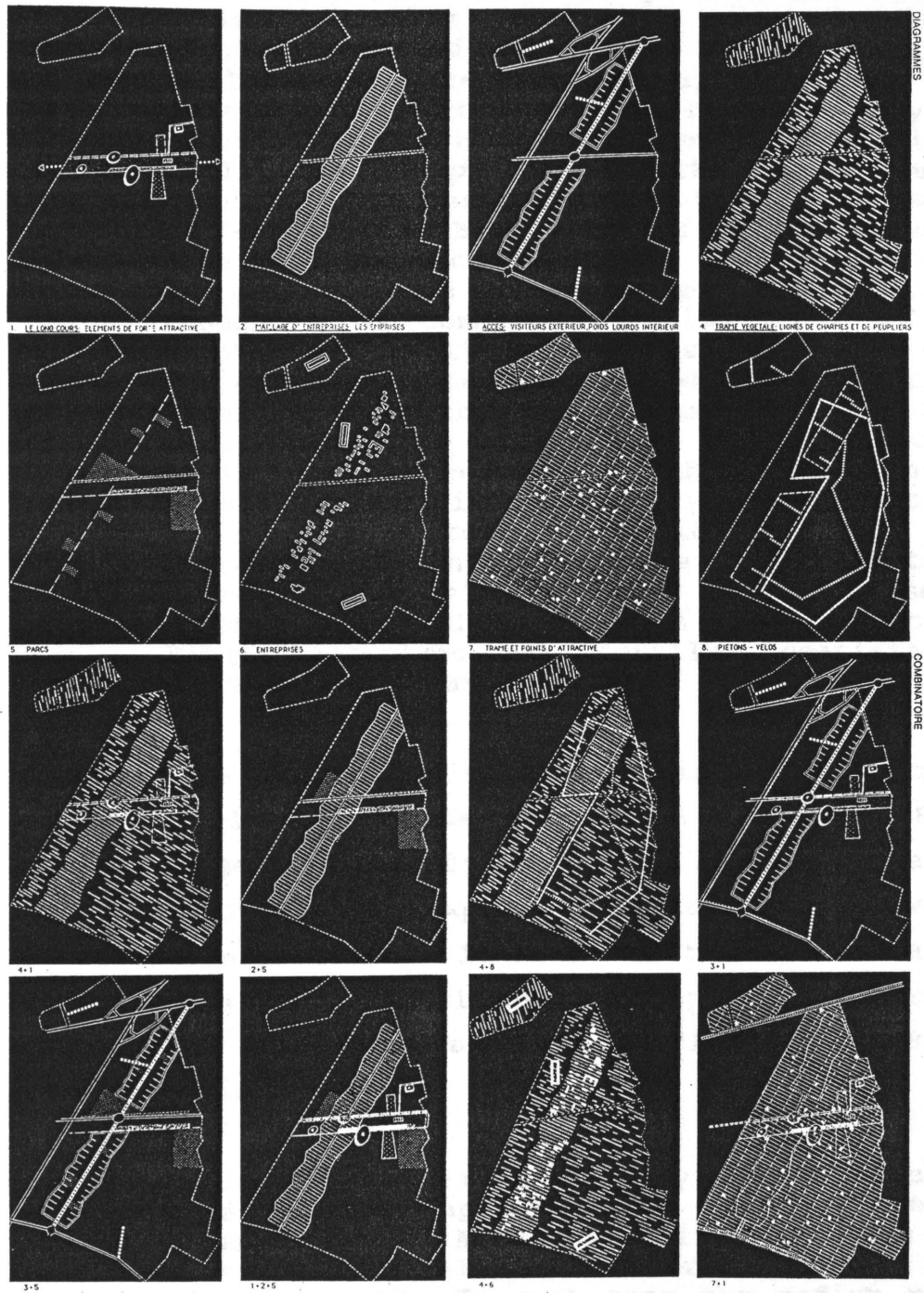
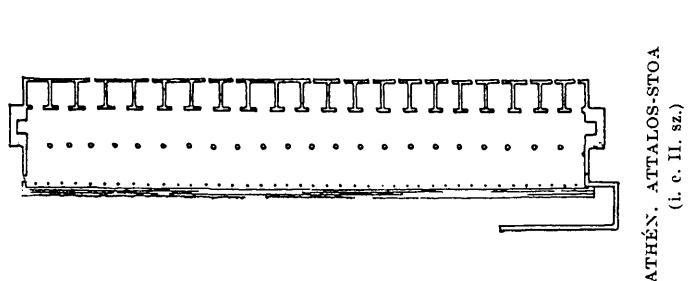
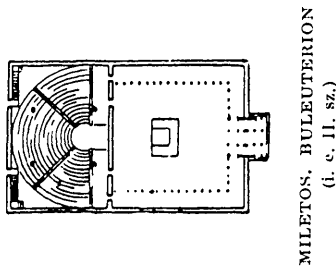
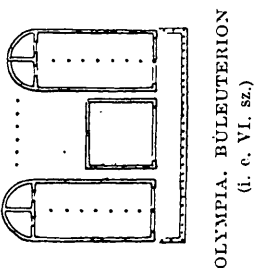

FIGURE 4.18 An office development with leisure facilities and housing on the outskirts of the town of Chartres - competition entry Bernard Tschumi (1991).

Recent experience of the post-modern brouhaha could have this conclusion as its epitaph. Architects should be reminded of the techniques of drawing and representation, which are their single most particular skill, when they are confronted with the crude historicist facadism of much currently published work. Plans are the result of a process which involves criticism and self-criticism. Both forms of criticism entail some dialogue between the eye and what is drawn on paper. Words need be neither spoken nor thought. The concepts in play need only be graphic or architectural. Post-modernism deals entirely with literal images which need words in order for the symbols to make sense. A plan needs none, and while drawing it the architect is simultaneously in contact with abstractions and a potential reality. A history of architecture, or even a history of building, needs this representation in order to tie it closely to the order of work which produces the discourse, of which any one plan is but a small component. Words themselves are totally unsatisfactory descriptions of architecture' (Dunster,1985:3).

Even more disturbing is the promotion of the computer graphic imagery of deconstruction (figure 4.18) as plan imagery. Initially intriguing in its complexity, it has now already acquired a gestalt of its own but without any content. It is as if the Wells tracings (figure 4.16) exist without any hope of a Cathedral. This has lead to Broadbent's (in Papadakis,1992:15) observation:

'I don't find my mind blown by complex, Duchamp-like images on paper any more; they look the same after a while. As do hard line drawings now, however thin the lines, however complex the forms they represent. In each case the medium really has become the message so they're not very



involving. I want our 'imagineers' ... to visualise spaces that even they with their consummate skills cannot begin to conceive on flat paper; spaces that cannot be drawn, and certainly cannot be built in any known - or yet as unknown - materials'.

Beyond computer graphic lies the electroglyphics (to coin a term) of the television screen where one can dwell in the ephemeral world of virtual reality (figure 4.19). The plan image, fractured by computer aided design, might be at the brink of extinction.

4.12 SUMMARY

The plan is more than the planning. By definition it is an abstracted graphic section to scale of the arrangement of building elements depicted through conventions on the horizontal plane. Yet not all plans have the same image. Through the musical analogy the original might show the style of the author, but even though transcribed still conveys also his intent. This persists while copies are extant, the building being merely an interpretation thereof. The manner of making of the plan allows for iconographic interpretation whereby its type can be ascertained and its historical time and place determined.

4.13 CONCLUSION

The third subproblem was to determine the relationship

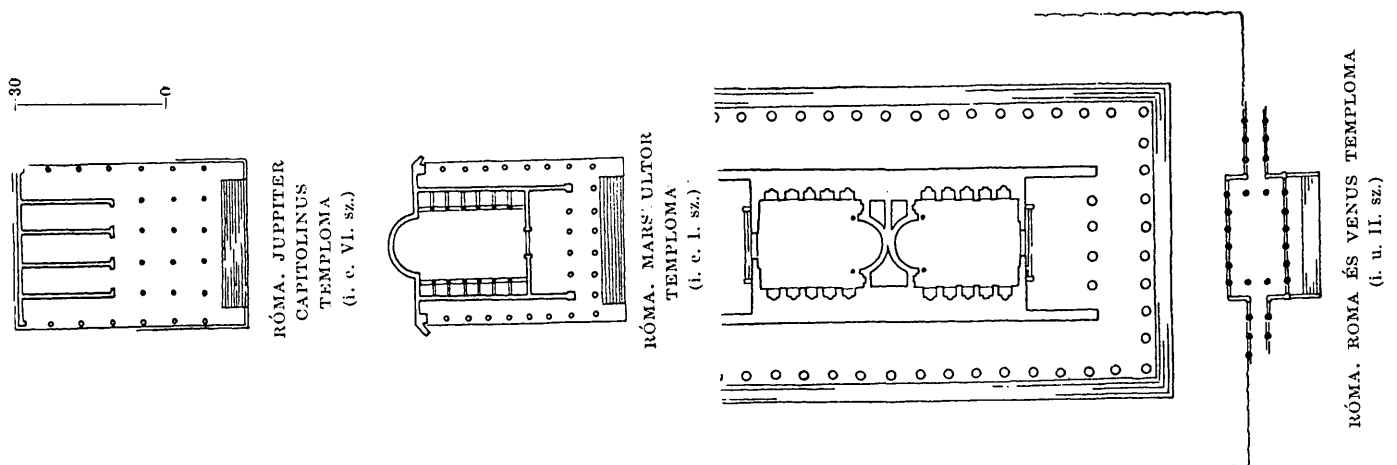

Opp. 54

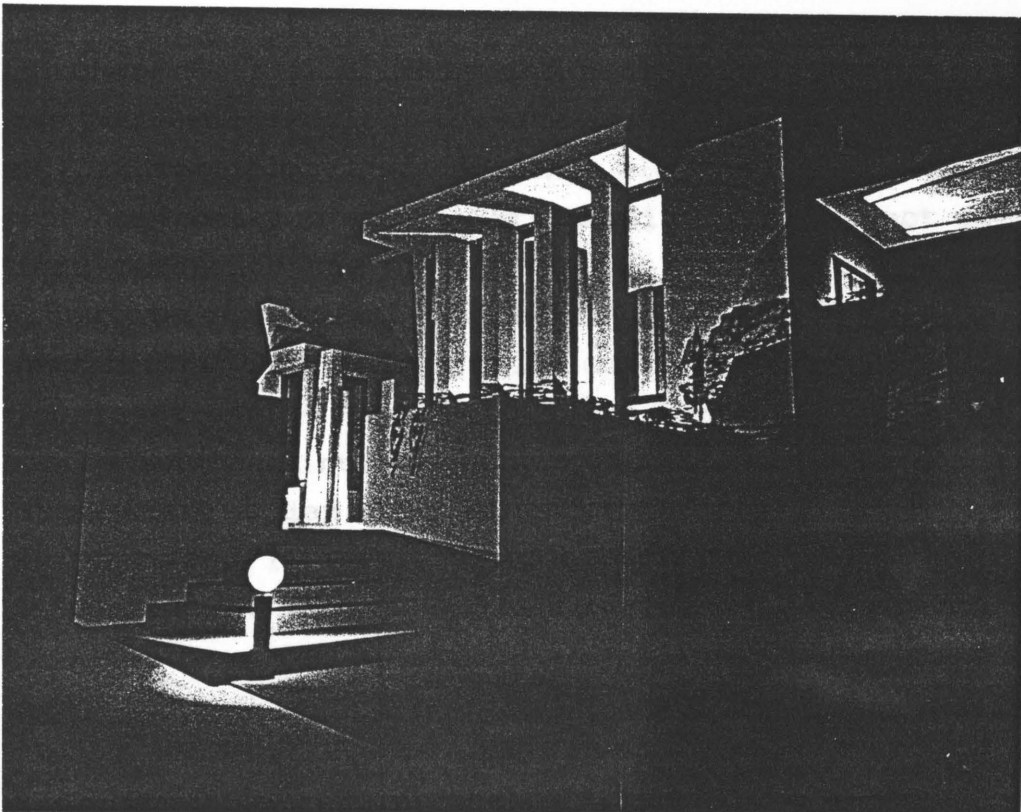
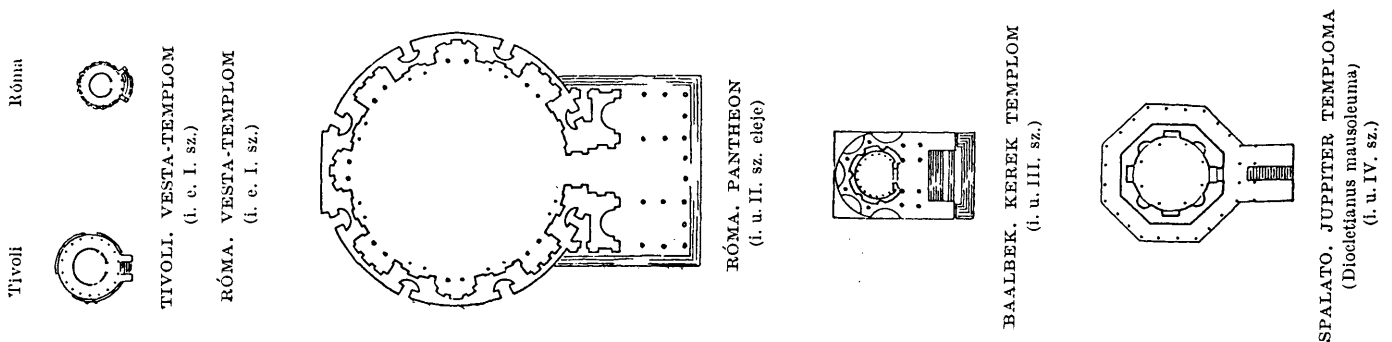

FIGURE 4.19 A night scene of an unbuilt Frank Lloyd Wright house by Intergraph.

of 'style' to 'plan'.

The third hypothesis was that the plan has style.

Iconographic interpretation allows for the association of the artefact with its type, place and time. The historical overview of the plan as artefactual type has given some insight into the manner of doing in its time and place of making. By definition the style of the plan allows for iconographic interpretation. Hence the plan must be said to have style. The hypothesis is thus supported by the investigation.



CHAPTER 5

THE ICONOLOGY OF THE PLAN

5.1 SUBPROBLEM 4

The fourth subproblem is to identify which aspects of the plan as image can be iconologically interpreted.

5.2 HYPOTHESIS 4

The fourth hypothesis is that the plan-image matches the hierarchy of visual recall, namely: image, sign, symbol and icon.

5.3 OUTLINE OF CHAPTER 5

In Chapter 5 the plan-image will be presented with associated meaningful readings: as a product of phenomenological and perceptual experience; as vehicle for homospacial thought and record of place and path; its identity of type and archetype and the recognition of these as the narrative of their location; the articulation and space-force fields as aspect of the discipline. The plan as sign, symbol and icon with appropriate examples will be explored and the rôle of the reconstructed and reproduced plan in iconological interpretation discussed.

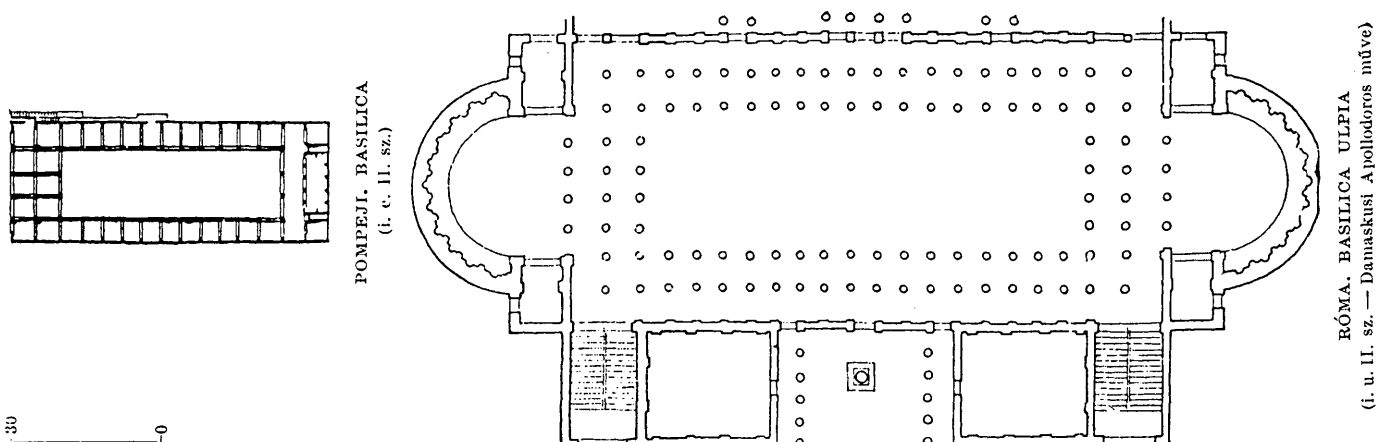

Opp. 57

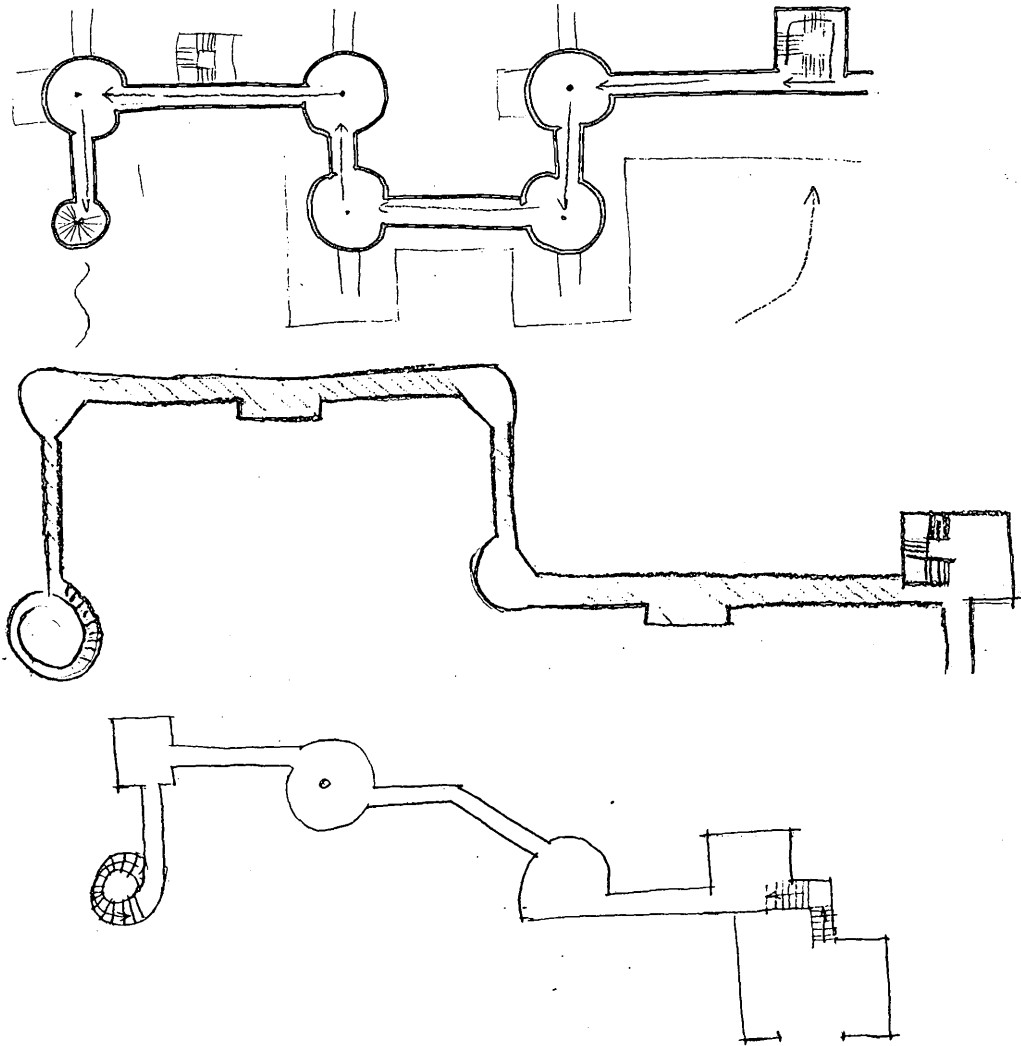
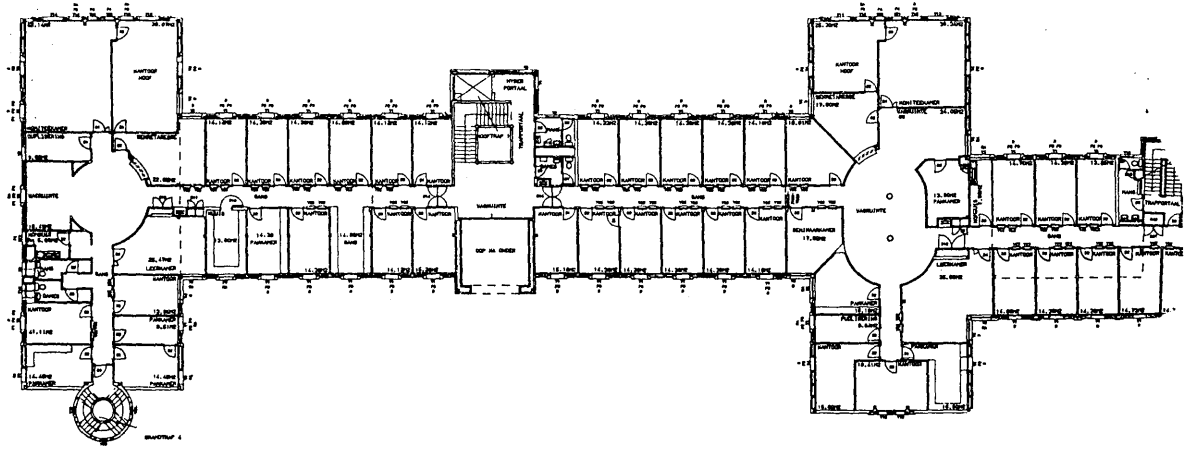

FIGURE 5.1 Plan of 1st floor of the Faculty of Economic Sciences, University of Pretoria.

FIGURE 5.2 Student representations of the passageway on the 1st floor, Faculty of Economic Sciences Building, UP.

5.4 INTRODUCTION

Even though the plans we have cannot all be iconographically related to their time of relevance they can still be 'read' as if of that time. This would suggest that certain abstract elements can be encoded into the plan and that these remain meaningful even in transcription. If the plan can be so encoded then it is available for iconological interpretation and can then be considered as a vehicle of meaningful information. What this information might be is dependant on the abstract qualities which avail for such encoding. In the following discussion some of these qualities will be presented.

5.5 THE PHENOMENOLOGICAL PLAN

'It seems remarkable that the true nature of a building should be revealed by its plan, that is, by view not available to anybody once the building is standing. ... When we walk through the intact building, its plan is distorted by perspective and broken up by partitions, and the simultaneity of the overall pattern is replaced by a sequence of vistas. Yet almost inevitably do we try to reconstruct mentally the plan of the whole from the partial glimpses we receive. When we succeed, the flash of insight is a genuine Aha-experience' (Arnheim, 1977:54).

This aha-experience is reinforced if one is shown also a drawing of the plan - 'At a glance we have grasped its essence' (Arnheim, 1977:54). Arnheim explains that

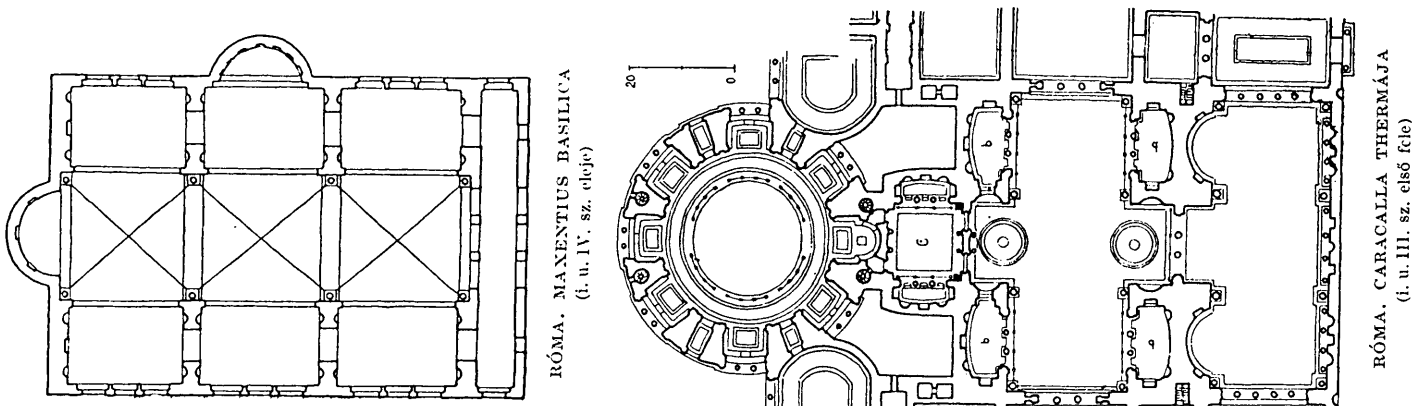

Opp. 58

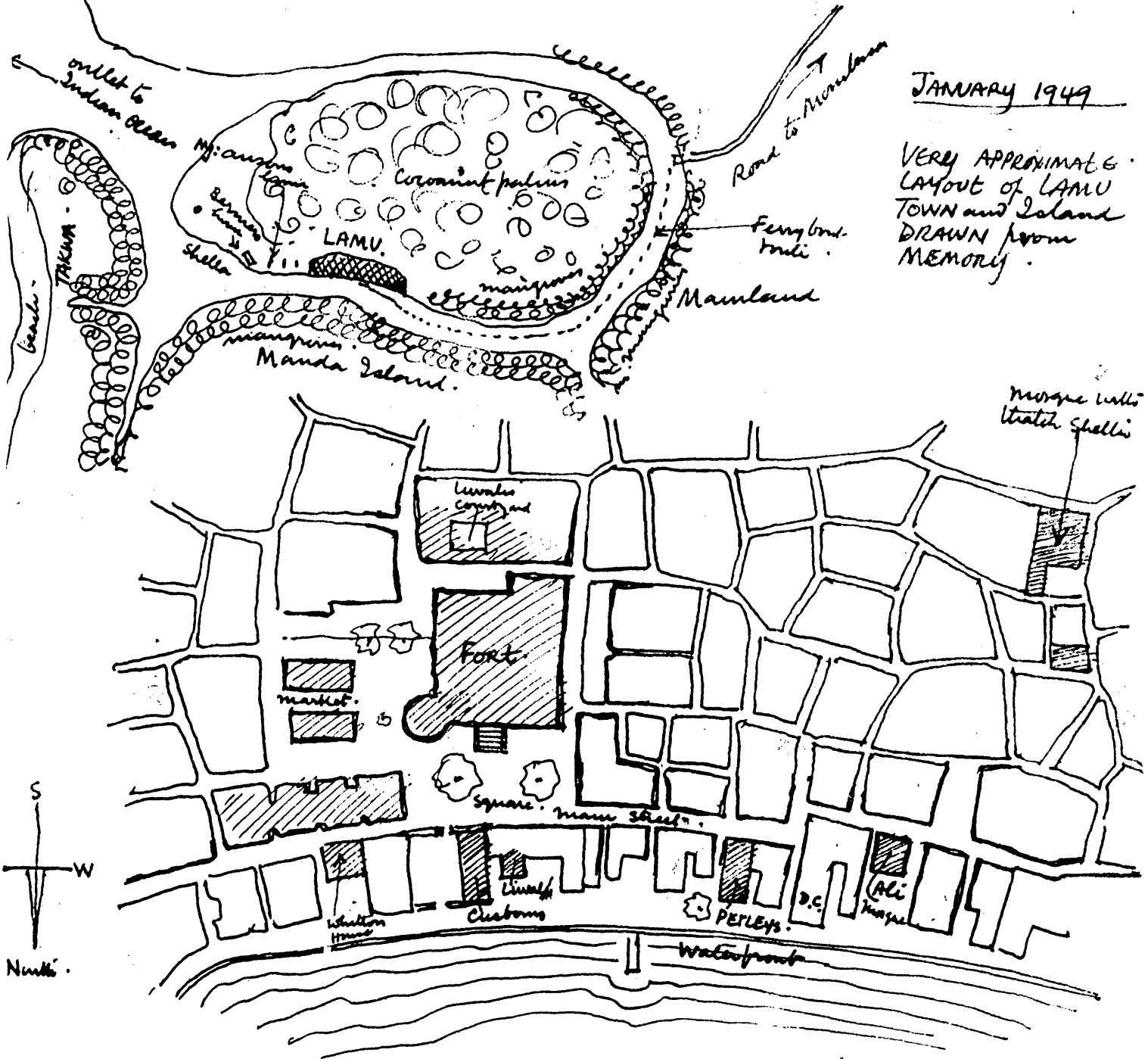

FIGURE 5.3 Eaton's 'Very approximate layout of Lamu town and island drawn from memory'.

the plan is the dimension of human activity whereas the section relates directly to the visual world. Hence the plan reveals something of the nature of the organisation of human activity.

The ability to 'map' the environment must be, to an extent, genetically predetermined and is related to the kinaesthetic perception and the commitment of this perception to memory. The translation of this memory, through the technique of graphic representation allows for the drawing of a plan which derives from such recall. Such plans are usually naïve (figures 5.1 & 5.2) but in the hands of the schooled architect can be very sophisticated (figure 5.3).

5.6 THE PERCEPTUAL PLAN

The edge of difference can be represented by line. The reading of the edge of difference allows for the mental construction of plan-form. As has been previously noted, this in most instances requires the integration of the many images perceived.

Porter (1979:27) has devised an exercise for the discovery of the plan-line. It requires that the viewer rotate through 360° and draw the perceptual boundaries where the ground meets the vertical plane. Were one to move to three different positions within the space and overlay the maps of the spacial boundaries the diagram would approximate the plan

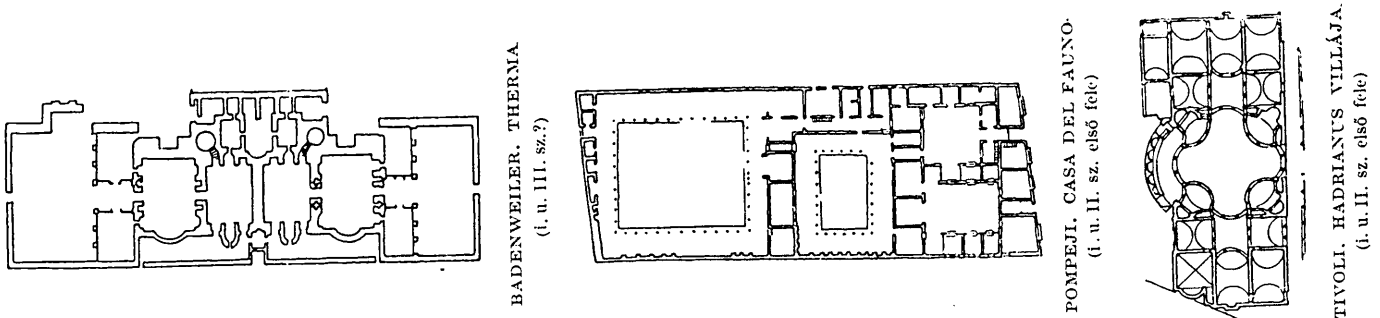

Opp. 59

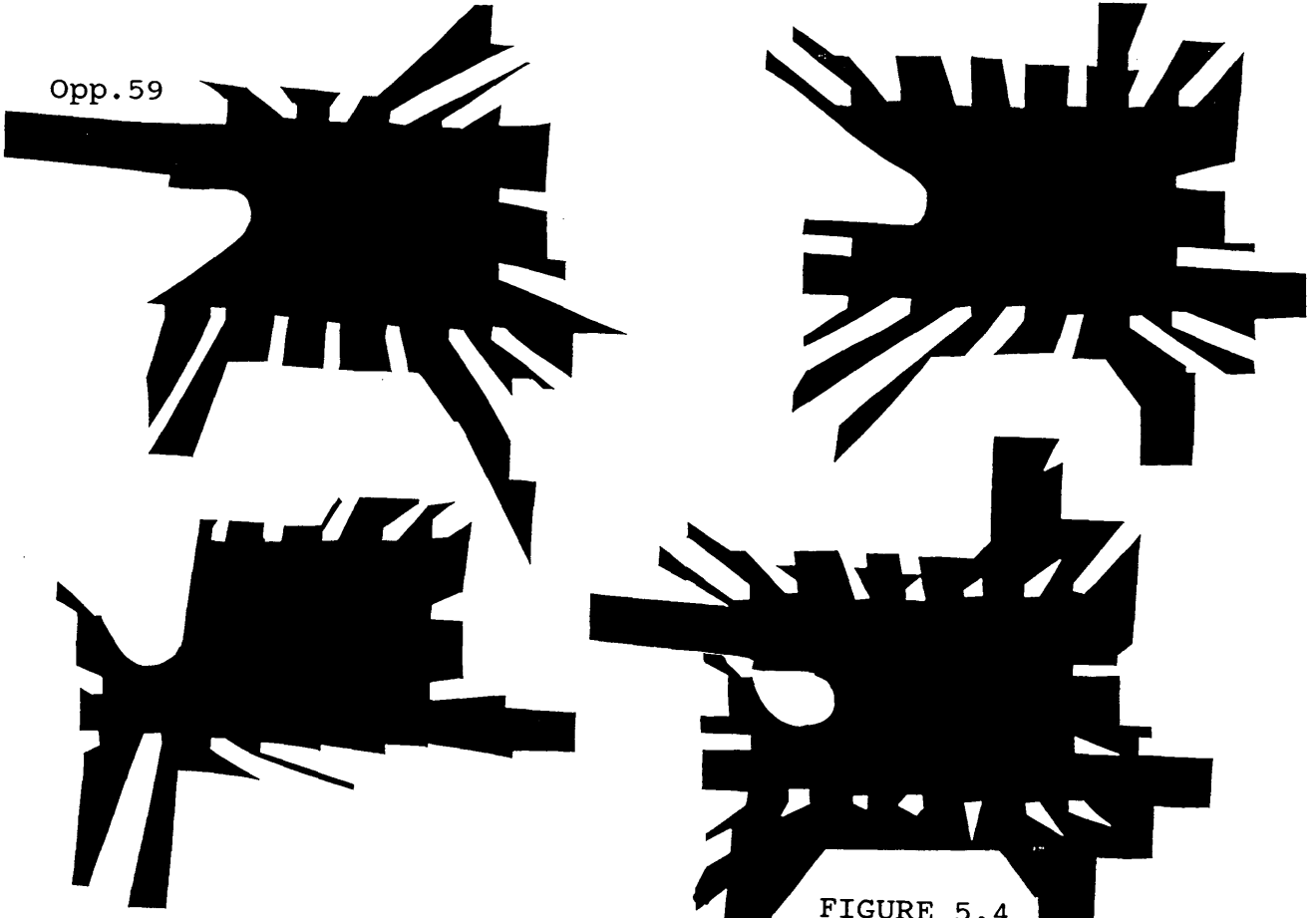

FIGURE 5.4

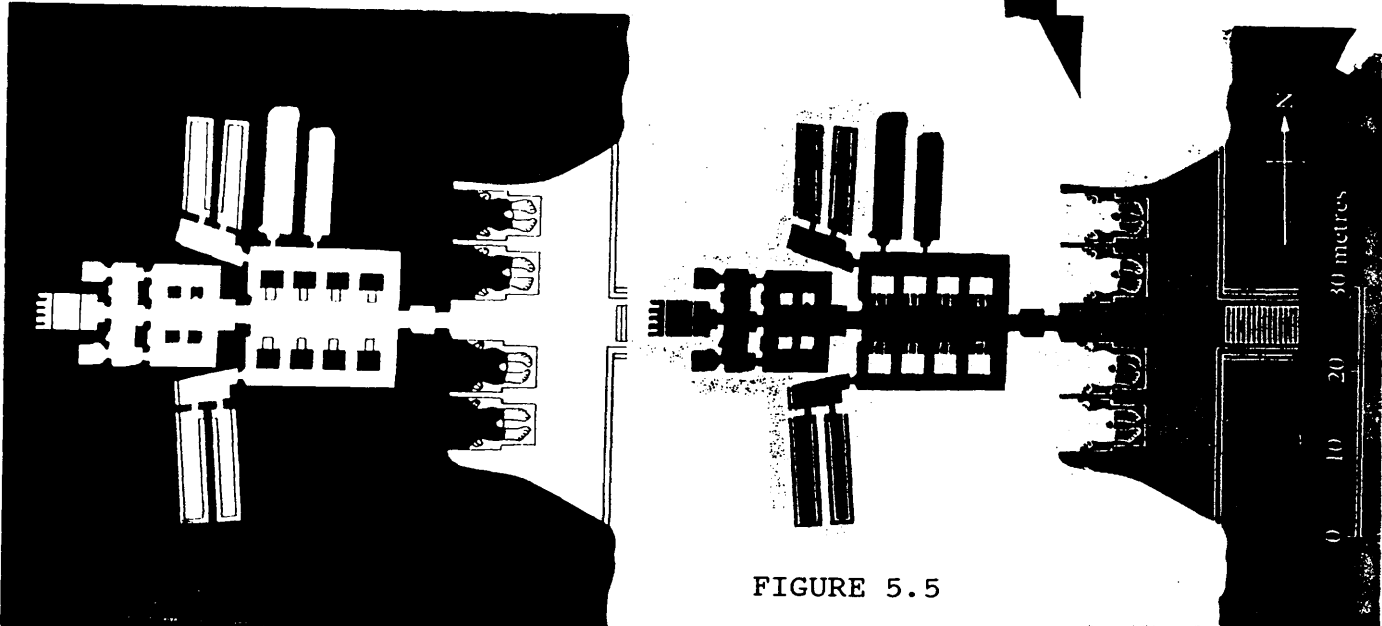

FIGURE 5.5

FIGURE 5.4 Three perceptual plans of Gildehuis and their superimposition.

FIGURE 5.5 The Temple of Rameses II, figure and ground image.

perceived in all directions. This exercise leads to the 'discovery' of the plan through the perception of its built boundaries and reveals the accuracy with which the plan can be recreated in the perceptive mind (figure 5.4).

5.7 THE HOMOSPACIAL PLAN

In perceptual studies the psychologists have developed the terms 'figure' and 'ground' to distinguish between the articulate object of perception, or 'figure', and the undefined, unbounded and receding plane wherein it is encountered or the so-called 'ground' (Arnheim, 1977:68-9).

The plan is usually seen thus, as a 'figure' drawing, and the residual space the 'ground'. Two aspects however are important in architectural thinking. The first is the process of 'reversal', where through focal change the complement becomes the 'figure'. The plan of the architecture of 'speos' (Martienssen, 1976:121), or excavated architecture, serves ideally to illustrate this (figure 5.5).

From the process of 'reversal', derives the concept of 'homospacial thinking' which is 'the simultaneous or conjunctive consideration of two or more aspects of the same spacial condition' (Faruque, 1984:157). The complement of the plan is usually termed 'negative

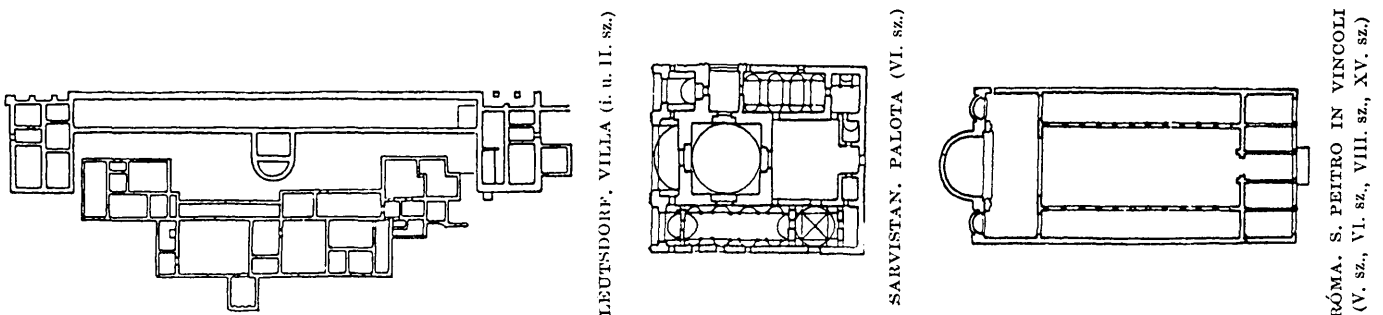

Opp. 60

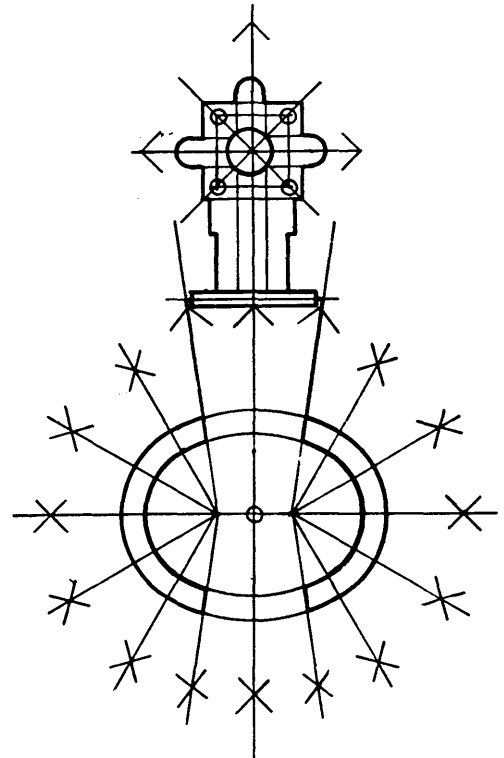
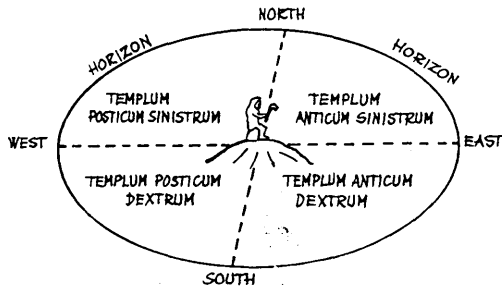
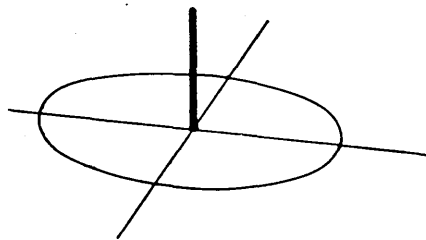
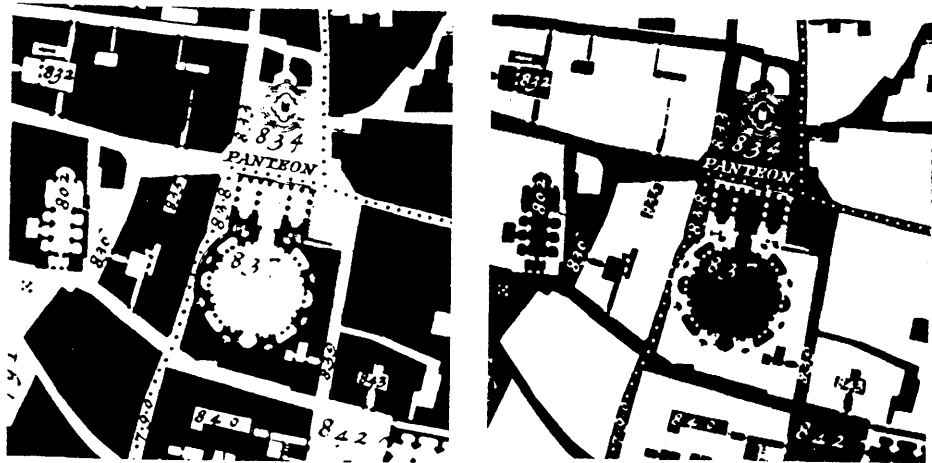

FIGURE 5.6 Nolli's map of Rome, detail, figure and ground representation.

FIGURE 5.7 The modeling of Man's existential space in terms of points and paths.

space' but in reality it is the 'positive' space enveloped or defined by the built form. Nolli's map of Rome (figure 5.6) ideally illustrates the idea of continuous spacial modulation by buildings. Modern graphic techniques now make it easy to generate the reversal of plan image and manipulate figure-ground configurations.

5.8 THE PLAN OF PLACE AND PATH

Norberg-Schulz (1971) has presented us with a theoretical discussion of the underlying elements of 'existential space'. In effect these aspects can be reduced to point as indicator of place and 'path' represented by line. The interaction of these two aspects determines the structuring of the spacial environment, when planning these aspects are concretised into the plan-form. Hence when the plan is read it can be reduced to the underlying aspects of 'point' and 'path' (figure 5.7).

5.9 THE PLAN OF TYPES

The plan-forms which occur repeatedly take on a gestalt image which allows for their identification in more complex compositions or modified form.

The megaron is recognised as a component of the complex layout of Tiryns (figure 5.8) for instance, or as the modified prototype of the Greek

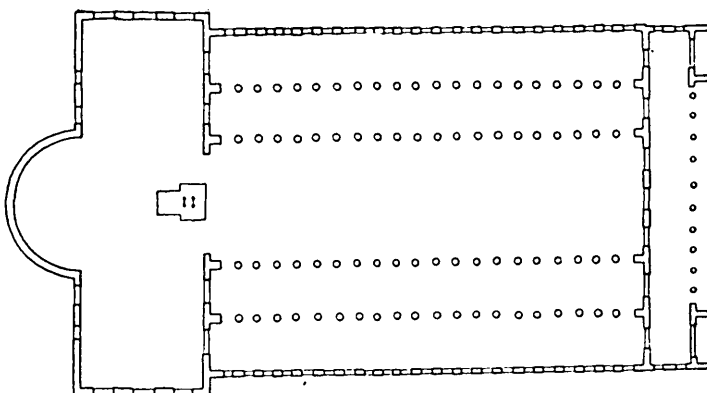

RÓMA. S. PAOLO FUORI LE MURA
(IV. és V. század fordulója)



CHIRBET BU ADUFEN TEMPLOMA
(V. sz. vége)

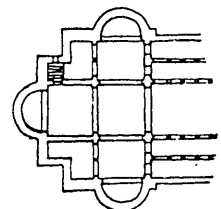

BETLEHEM. SZÜLETÉS-TEMPLOM
(IV. sz., VI. sz.)

Opp. 61

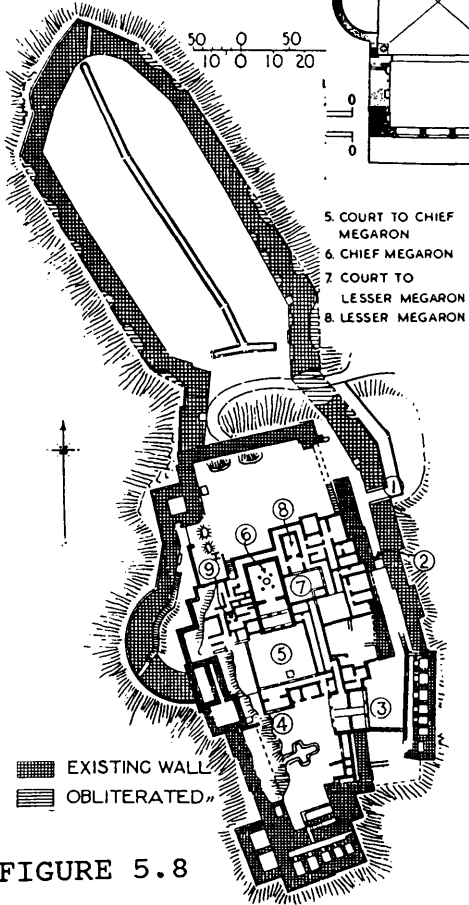

FIGURE 5.8

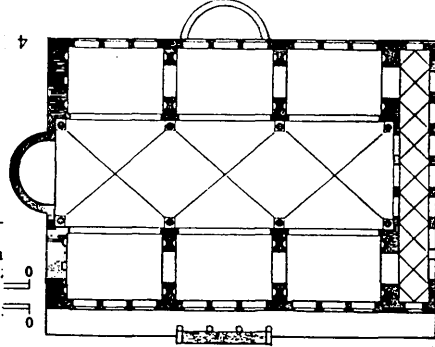

FIGURE 5.10

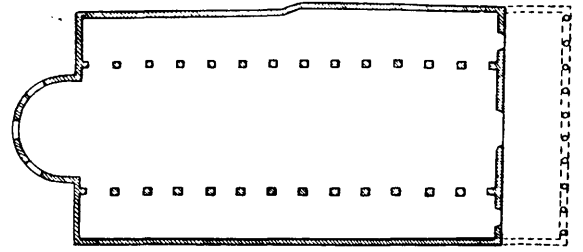

FIGURE 5.11



FIGURE 5.12

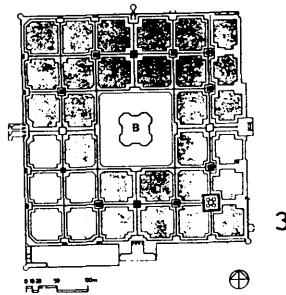
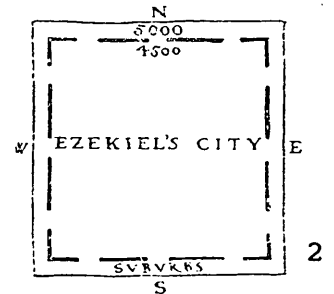

FIGURE 5.13

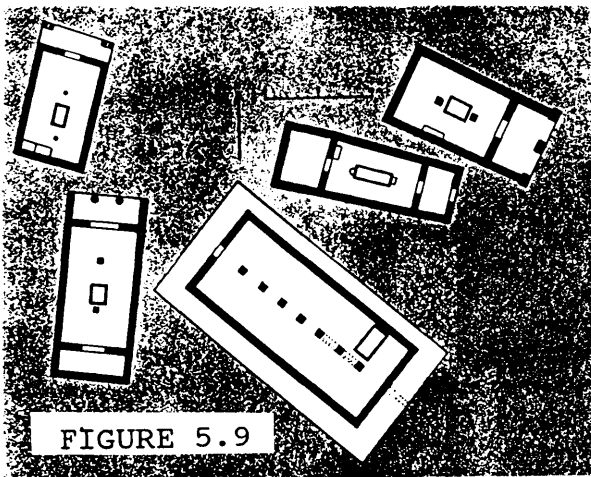
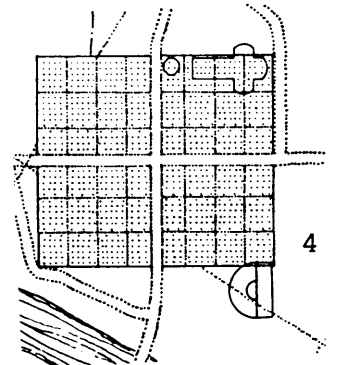

FIGURE 5.9

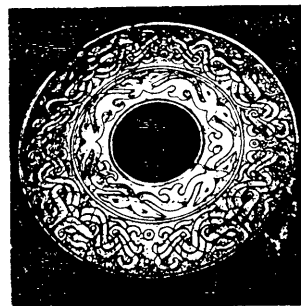

FIGURE 5.14

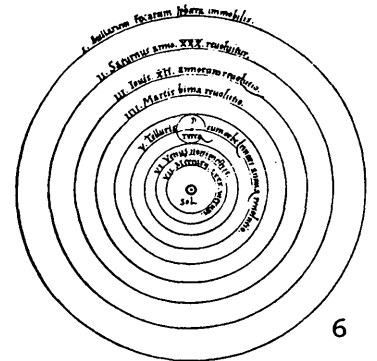

FIGURE 5.8

The megarons of Tiryns.

FIGURE 5.9

The Greek Megaron Temples.

FIGURE 5.10

Roman Basilica of Maxentius, C4.

FIGURE 5.11

The basilica church of S Sabina, Rome.

FIGURE 5.12

The Earth four-square.

FIGURE 5.13

The paths of life.

FIGURE 5.14

The sphere of heaven.

temple (figure 5.9). The Roman basilica (figure 5.10) is seen as being source to the plan of the basilica church (figure 5.11).

5.10 THE ARCHETYPAL PLAN

Lethaby (1977), Norberg-Schulz (1975) and Thiis-Evensen (1987) have all promoted the understanding of architecture in terms of its archetypal content. The plan-form lends to the reading of three universals.

Square - this form relates to the earthly domain (figure 5.12) and man's place on earth.

Cross - this form derives from the heavenly and seasonal activity and relates to these cycles (figure 5.13).

Circle - this form has the sense of cosmos and relates to the constancy and completeness thereof (figure 5.14).

5.11 THE NARRATIVE PLAN

The idea that the plan is a 'spoor' or 'footprint' has been promulgated.

But this is finding a metaphor in the abstraction. Unlike the paw of an animal or the human foot, the building cannot be put down and then lifted to leave a

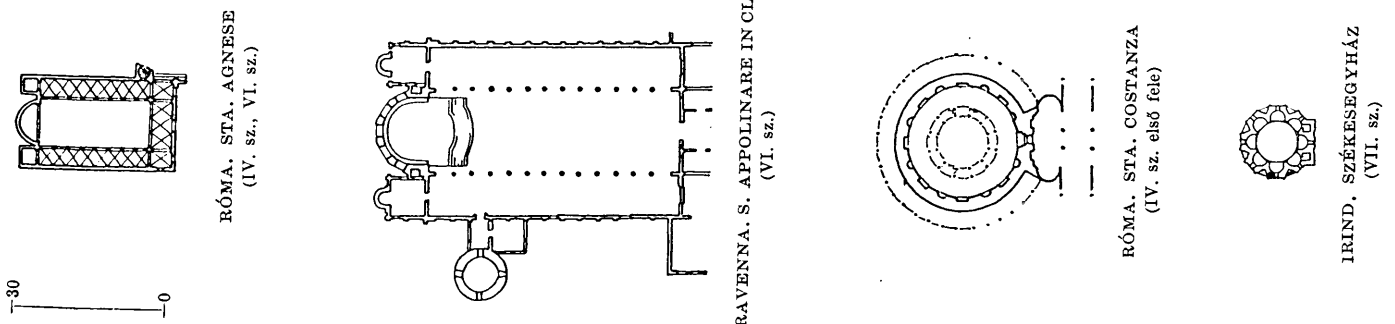

Opp. 62

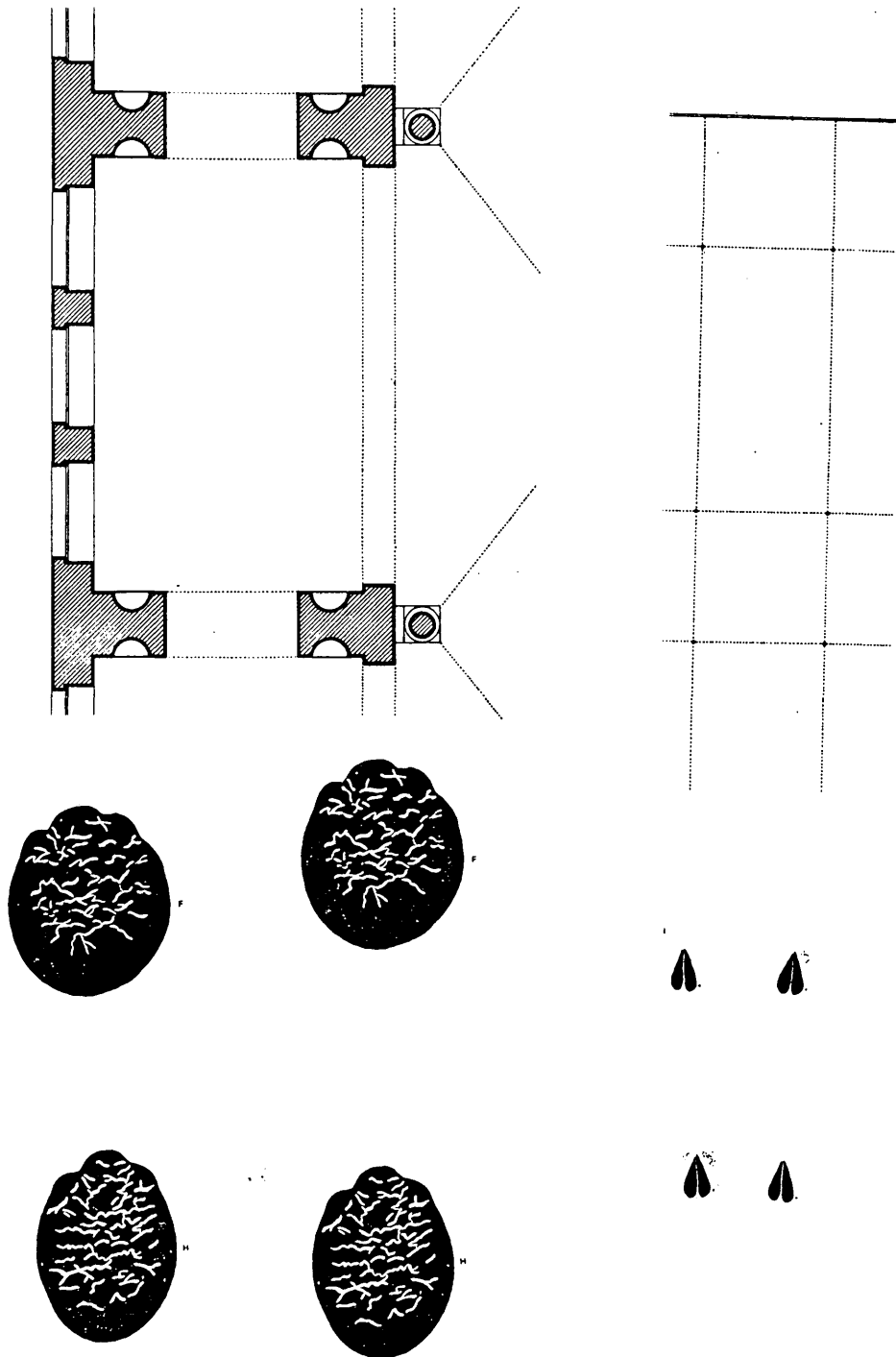

FIGURE 5.15 A comparison of the structural bays of the Basilica of Maxentius, Rome and those of the Crystal Palace, London and their footprint analogies.

recognisable imprint. Most buildings, like a tree, start their structural systems beneath the ground and what emerges is the resolution of this system into a space-envelope. Yet there is something in the 'footprint' analogy which alerts us to a particular quality of the plan.

'The plan may be considered in a sense as the "spoor" of a building. Just as an elephant will leave a large and positive imprint of its foot, and a small antelope a delicate hoof-print, so a structure of heavy stone will show in its plan a far bolder silhouette than a light structure of glass and metal [figure 5.15]. Carrying the footprint analogy a little further we may say that it is not only size and weight that are indicated but other characters of the building; as with animals the marks indicate hoof or pad, and by distribution, speed of travel, and thus possibly state of mind from tranquility to terror' (Martienssen, 1976:116).

'Man also has been leaving behind traces of his roving round the world. These traces speak of customs, techniques, social orders and the soul of our ancestors, who, with their ambitions, their tenacity, their successes and their failures, have forged the present for us - a present in which we, in turn, prepare the way for others. The tangible form of the "footprints" left by mankind in its march through history is constituted by the remains of its works - the ruins of cities, of temples and palaces, of private and public buildings.

. . .

Each of these monuments constitutes a sign of a certain kind that we must discover and comprehend. A monument is rooted in the ground; when its disappears it leaves behind a cast or

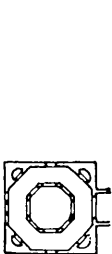

EZRA. SZT. GYÖRGY TEMPLON (VI. sz.)

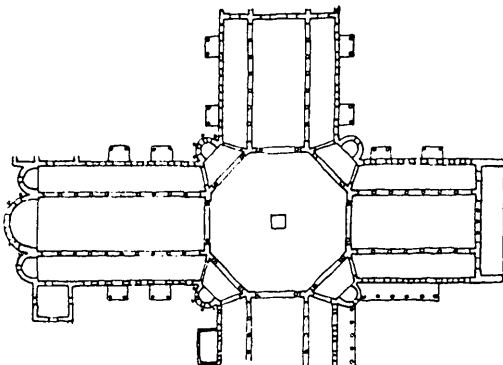

KALAT SIMAN (V. sz. vége; VI. sz. eleje)

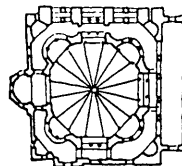

KONSTANTINÁPOLY.
SERGIUS ÉS BACCHUS TEMPLOMA
(527-538)

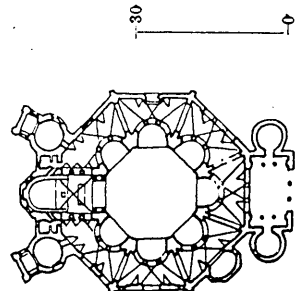

RAVENNA. S. VITALE TEMPLOMA
(526-547)

Opp. 63

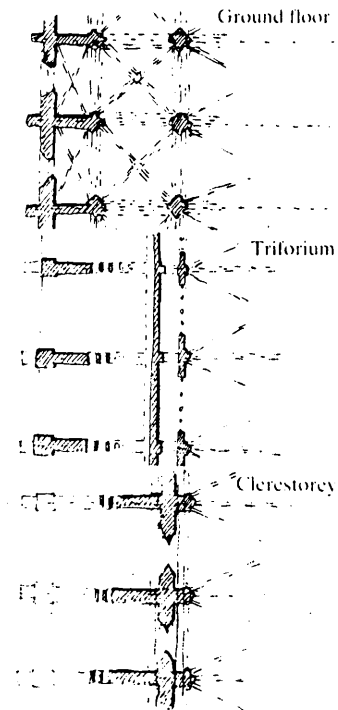
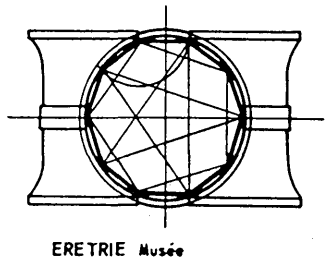
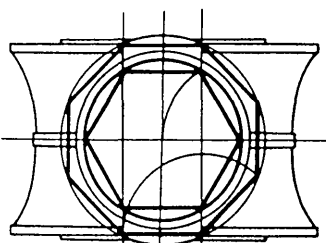

FIGURE 5.17



ERETRIE Musée



DELPHES STOA des ATHENIENS

FIGURE 5.18

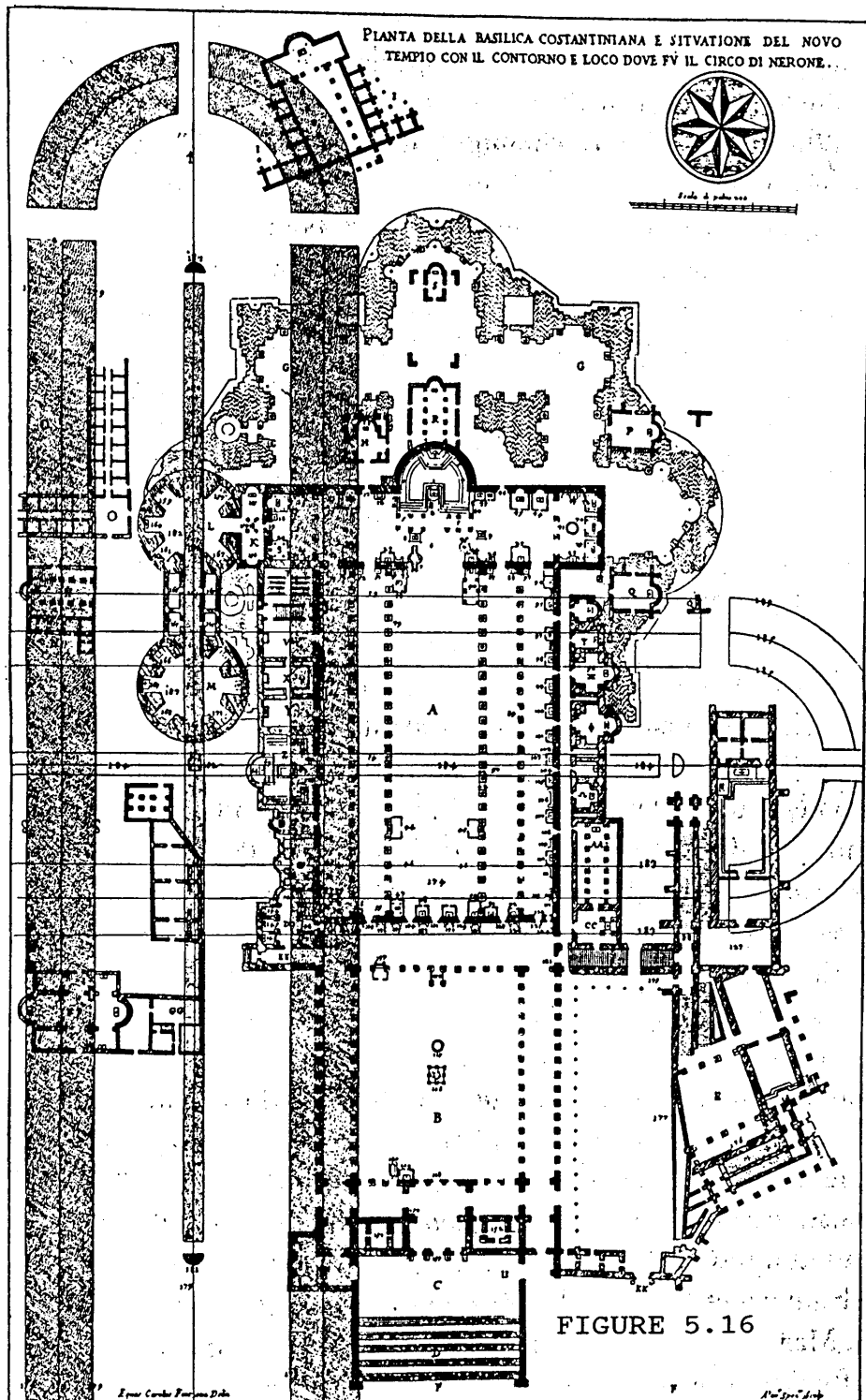

FIGURE 5.16

FIGURE 5.16 A palimpsest of plans including a Roman Hippodrome, Old St Peter's Basilica and New St Peter's Cathedral as depicted by Alfarani.

FIGURE 5.17 The articulation of a Gothic Cathedral.

FIGURE 5.18 The Articulation of Ionic columns.

mould. The foundations of each buildings are peculiar to, and characteristic of, each age and civilization. Or, in others words, this "footprint" reflects the spirit of its builders.

. . .

The ground plan is the image of the footprint of a building. It is the imprint that the building leaves on the ground. This contact is peculiar to each historical moment. The footprints that each age leaves have much greater significance than we suppose at first thought. These footprints are rather like an X-Ray of the age: they reflect the technique, the social and economic conditions and the very soul of the people' (Sacriste, 1968:9-10).

A palimpsest of plan images (figure 5.16) revealed through the endeavours of archaeologists would be unintelligible if we were not able to distinguish the different plan types. Like in the spoor analogy each can be allocated to the culture of its making and in the reading and interpretation tell the story of the place of their making.

5.12 ARTICULATION

The plan reveals something of the manner in which disparate elements, diverse materials or structural systems are reconciled and resolved. This can often only be insinuated because of the scale of depiction but it is in the essence of the architectural enterprise. It is here that one discovers the resonance between the macro- and microscopic aspects

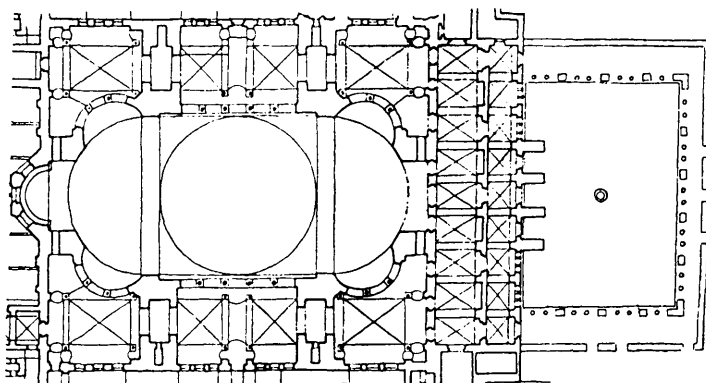

KONSTANTINÁPÓLY, HAGIA SOPHIA
 (VI. sz. — XIV. sz. — Trallesei Anthemios és
 Miletosi Isidorosz műve)

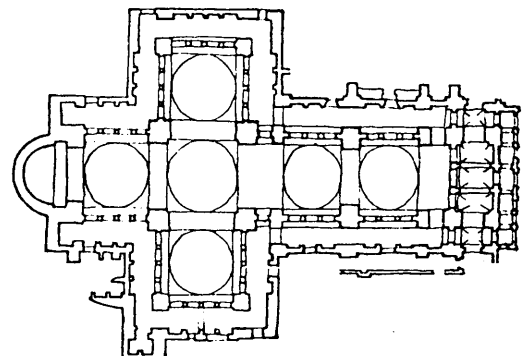

EPHEZOS, SZT. JÁNOS TEMPLOM
 (VI.—VII. sz.)

Opp. 64

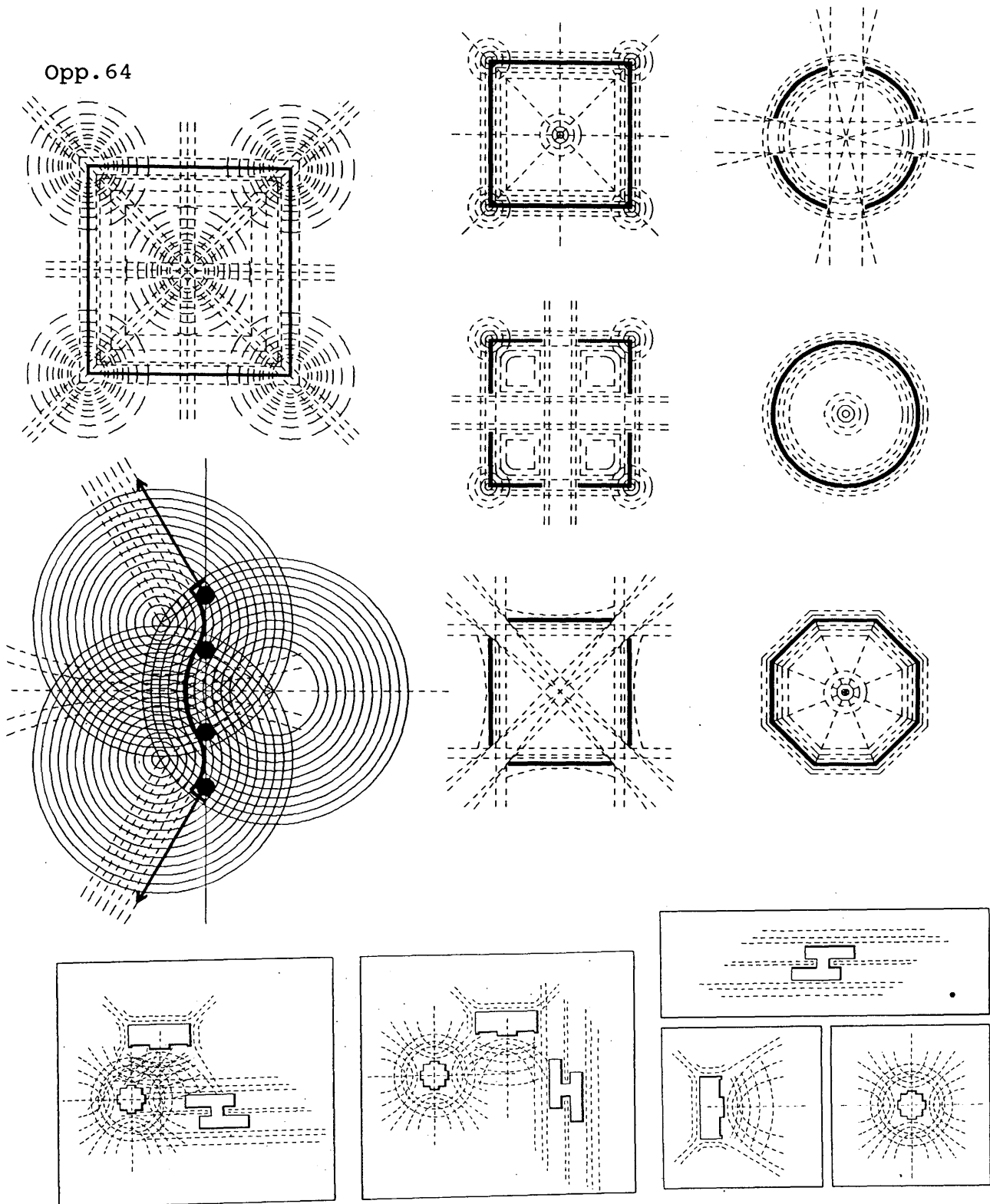

FIGURE 5.19 Some depictions of space force-fields after Portoghesi.

of the design. Successive horizontal plan sections, in their changing form, speak of the articulation of the building through space (figure 5.17) or of the element along its length (figure 5.18).

5.13 THE SPACE-FORCE FIELDS OF THE PLAN

In terms of techniques developed by Portoghesi (1968), tendered by Arnheim (1977) and exploited by Meiss (1992) architectural forms can be thought of as having a 'radiance' of spacial fields, the interaction of which create 'space-force' field. The plan form can be explored graphically for discovery of these spacial fields. This is a technique whereby the figures of the buildings or elements are seen as being in the 'ground' or spacial pool and, much as the ripples of flung pebbles create patterns of wave amplification or interference, reinforce or negate the presence of each other (figure 5.19). How each form or element is manipulated or where openings are placed will determine the character of the 'field pattern'. Conversely, the consideration of the field patterns of adjacent elements will influence the reading of elements and of openings.

5.14 THE PLAN AS IMAGE

In Chapter 2 it was determined that the image is the primary form of meaningful visual association as 'a pictorial representation produced by the imagination'.

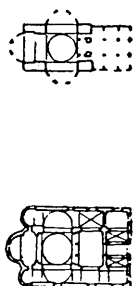

KONSTANTINÁPOLY,
KODJA MUSTAFA DZSÁMI
(Szt. András temploma)
SZALONIKI,
ST. ELIAS (XI. sz.)

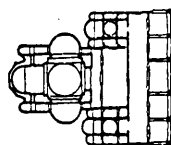

LAWRA. KOLOSTORTEPLOM
(X. sz.)

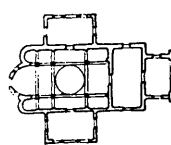

TRAPEZUNT. HAGIA SOPHIA
(XI–XII. sz.)

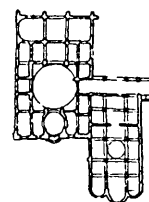

STIRIS. HOSIOS LUKAS
(X–XI. sz.)

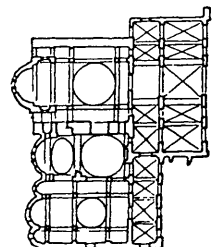

KONSTANTINÁPOLY,
HAGIOS PANTOKRATOR
(XII. sz.)

Opp. 65

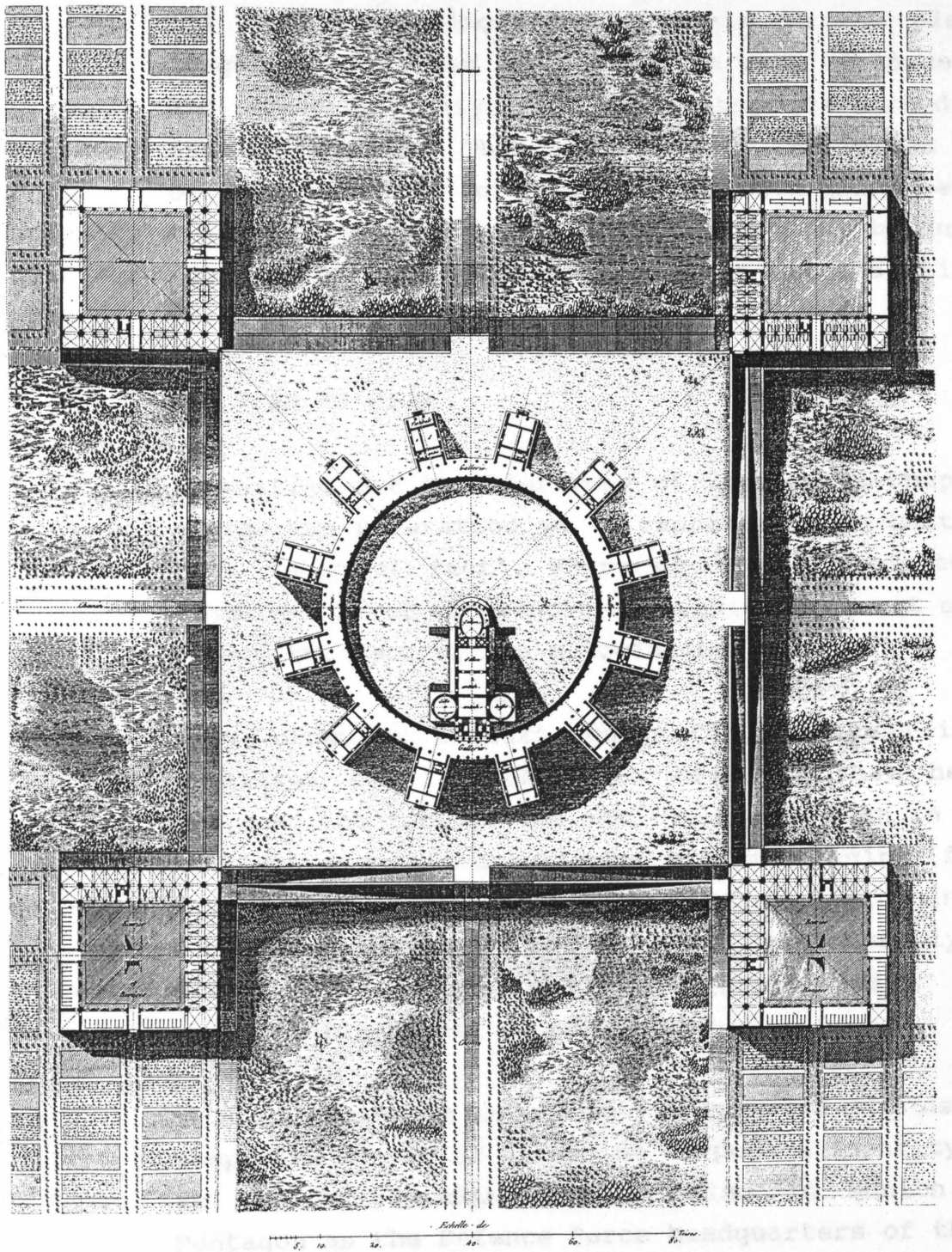

FIGURE 5.20 The Oikema at the Ideal City of Chaux, Ledoux.

All the afore-going aspects relate to the plan as image. The plan can be examined in each of these ways and through analysis significance discerned and meaning ascribed. This is however at the lowest level of the hierarchy of meaning. Certain plans embody meaning at higher levels in the hierarchy because of the programmatic requirements or an eventful time of their making.

5.15 THE PLAN AS SIGN

In setting out the hierarchy of imagery in Chapter 2 a sign was understood as 'a representation that acts as a token of fact'. Where plans are exploited as signs the level of associated meaning does not extend beyond the fact of the association.

If we consider Ledoux' design for an Oikema in his idealised town of Chaux we discover that he has employed the form of the phallus in the plan in order to alert us to the functioning of the building (figure 5.20). It must also be remembered that ballooning was a recently discovered mode of travel and possibly this novelty also encouraged the exploitation of a recognisable object as plan form.

The plan as sign or 'logo' is now readily used by companies by way of extending corporate identity such as the BMW headquarters building in Munich. The Pentagon as the Defence Force headquarters of the

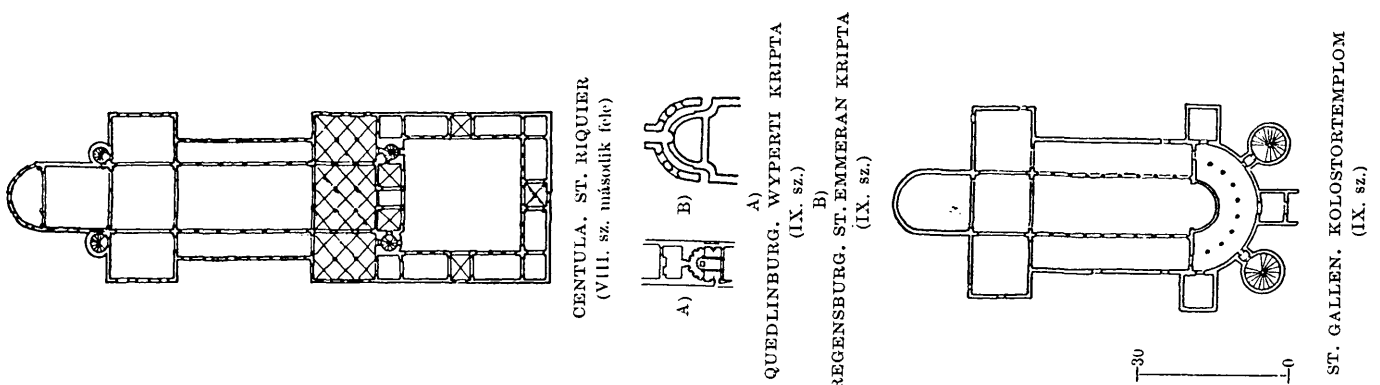

Opp. 66

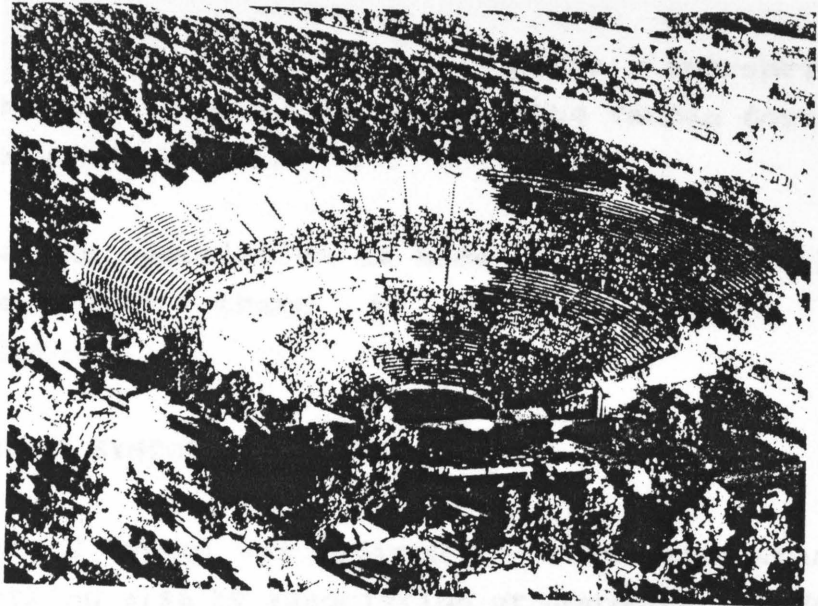

FIGURE 5.21

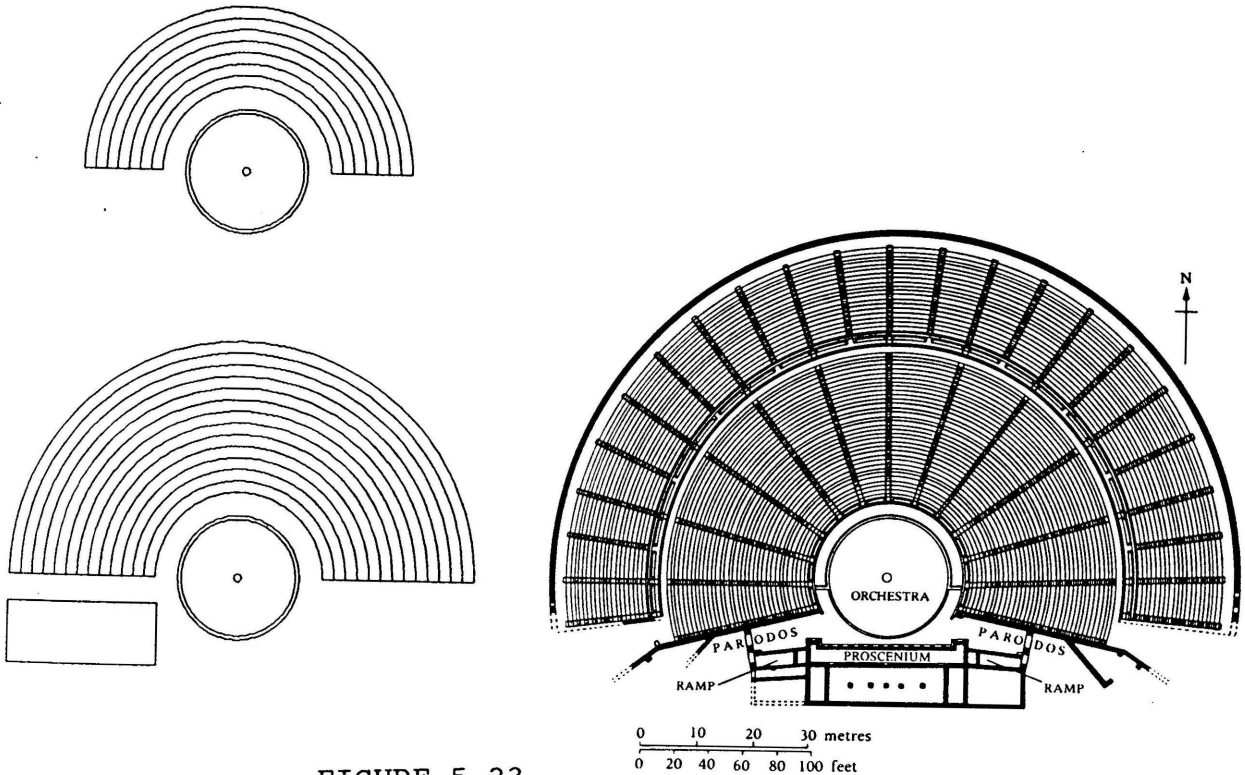

FIGURE 5.23

FIGURE 5.22

FIGURE 5.21 The theatre at Epidauros.

FIGURE 5.22 A plan of the theatre at Epidauros.

FIGURE 5.23 A schematic representation of the development of the Greek theatre form.

United States of America gains appropriate representation by association with the Vauban fort as a defensive structure.

Yet once the association is made in these and other suchlike cases there is nothing further to contemplate.

5.16 THE PLAN AS SYMBOL

In Chapter 2 symbol was defined as 'that which stands for something else by association or convention'. Many building types have associated meanings but the theatre, both in its history and in its function has probably the richest associations.

The root of the theatre is the Greek word 'theasthai' meaning 'to look at' which is related to the Greek 'thauma' meaning 'miracle' (Collins, 1979). Why should theatres and miracles bear a relationship?

'Theatre' derives from the ancient Dionysian rites performed on the threshing floors to celebrate the harvest. The threshing floor in itself has the cosmic emblem of circle and centre and through the rites is linked to the cosmic consciousness of cyclical death and rebirth. The first theatres were thus the threshing floors and celebrated the miracle of the perennial rebirth of nature as provider for sustenance.

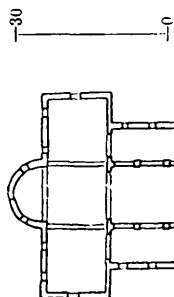

AUGSBURG. DÓM
(IX. sz.)

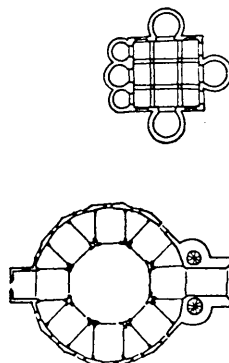

AACHEN.
PALOTATEMPLOM PRÉS. TEMPLOM
(VIII. sz. vége)

GERMIGNY DES
PRÉS. TEMPLOM
(IX. sz. eleje)

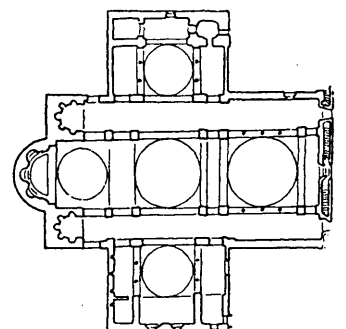

VELEENCE. SAN MARCO
(IX.-XII. sz.)

The formalisation of the rites lead both to the development of Greek plays and the theatre as building type so as to accommodate both the performance by the players on the 'orchestra' - the ancient threshing floor, - and the spectators (figures 5.21, 5.22 & 5.23). The root of 'spectator' is the Latin term 'specere' meaning 'to look at' through which it is linked to 'speculate' meaning 'to meditate on a given subject, reflect (American,1970:1). In root meaning theatre-goers and spectators are allied and so too are 'speculations' and 'theories'. 'Theory' has as its root the activities of Greek theatre-goers (Williams,1981:316-8), which, through metaphor, has given us the meaning of

'systematically organised knowledge applicable in a relatively wide variety of circumstances; especially, a system of assumptions, accepted principles, and rules of procedure devised to analyze, predict, or otherwise explain the nature or behaviour of a specified set of phenomena' (American).

Whereas the root term has been abstracted into metaphor the plan, once cosmic, has been narrowed by functional requirements of tiered seating and stage. But even in its secularised form the theatre still evokes something of the mystery of its origins and the universality of its messages.

5.17 THE PLAN AS ICON

In Chapter 2 an icon was defined as 'a symbol

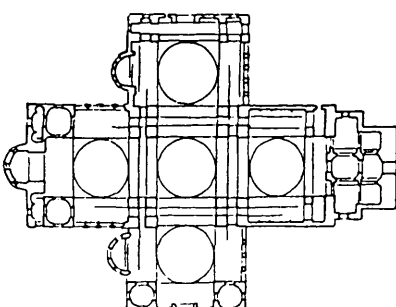

PERIGUEUX. S. FRONT
 (XII. sz. elejc)

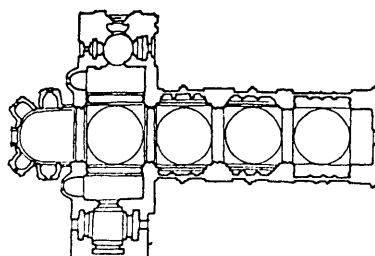

ANGOULÊME. KATEDRÁLIS
 (XII. sz. elejc)

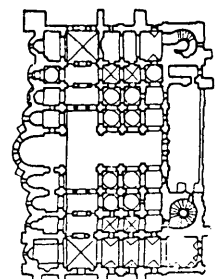

KIEV. SOPHIA-TEMPLOM
 (XI. sz.)

Opp. 68

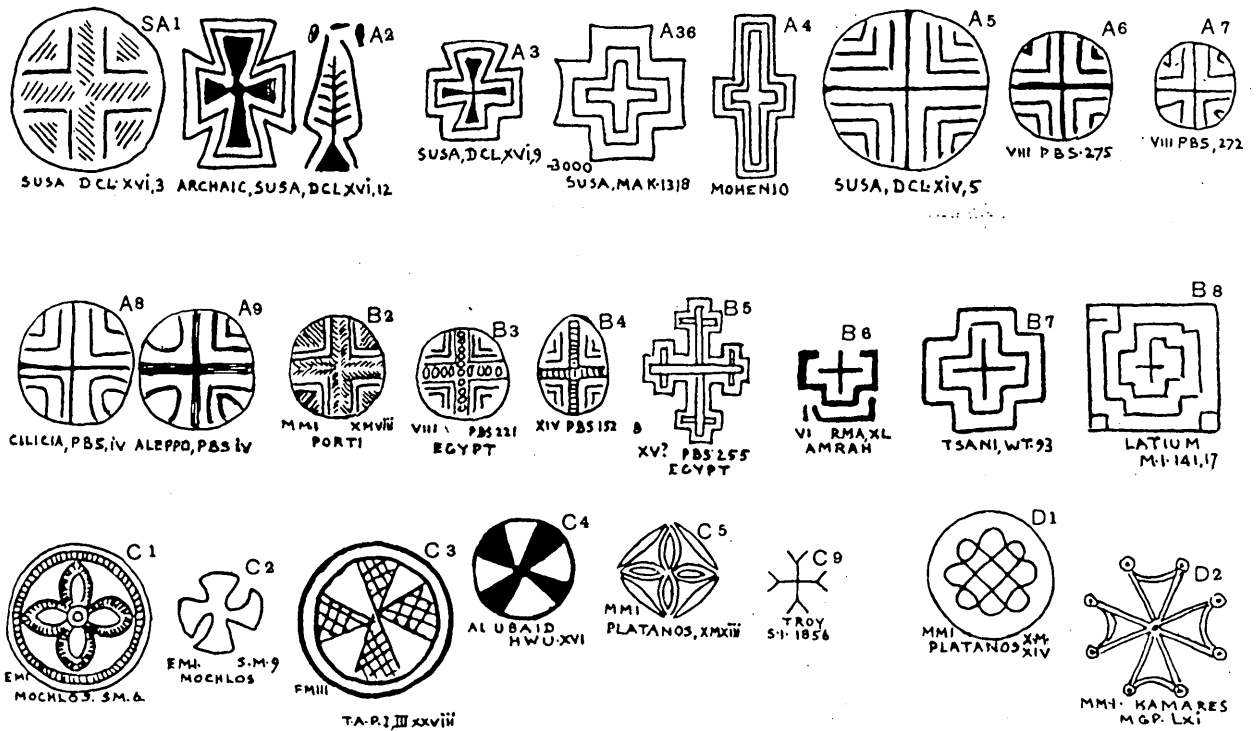

FIGURE 5.24

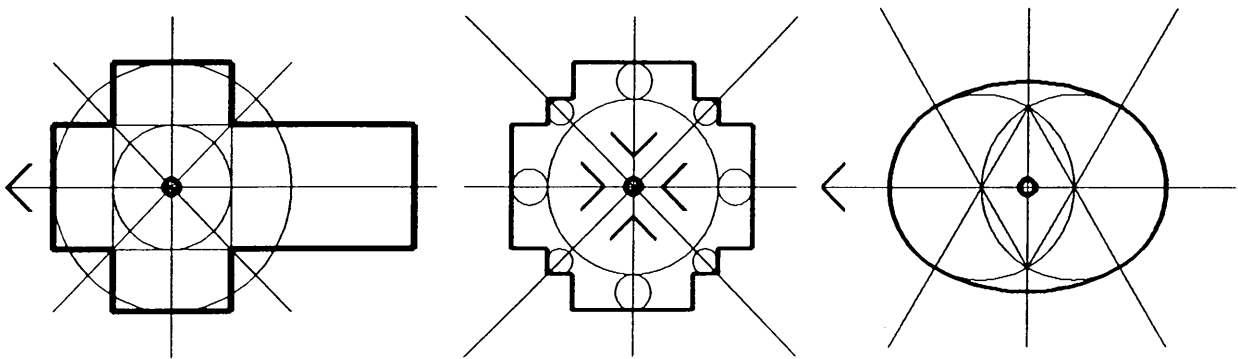

FIGURE 5.25

FIGURE 5.24 Representations of the cross-shaped motif before 2000 BC (After Flinders Petrie 1930).

FIGURE 5.25 Diagrammatic representation of the centralisation of the point of crossing in the Christian Church.

analogous to that which is represented'. No plan serves better than that of the Christian church.

'It is well known that Christian churches incorporated the shape of the cross in the plan of the building. Though this would surely not have happened had the symbol of faith been a different shape such as the crescent' (Gombrich;1979:248).

In fact, the original Christian symbol was the vesica piscis, the anagrammatic representation of the avowal of faith. The cross as a motif can be traced back through the millenia (figure 5.24) but as a Christian symbol was depicted extensively only after Europe was entirely Christianised (Clark,1974:29).

'We can ... draw on the parallel with etymology to illustrate [the] ... fluctuations in intensity of meaning which is still felt to be present in the sign. The word cross derives from Latin crux which really means pain or torture, but thanks to the transfer of the word to a particular configuration the original meaning has been forgotten' (Gombrich,1979:247).

Yet it is not as symbol that the form of the Christian church has significance. It is for this reason that the suggestion that if the symbol had been a crescent that it would never have achieved built-form is absurd. It is because the church as built-form is analogous to the Christian life - baptism, path of redemption, death and resurrection that the plan-form has significance. It is here that Arnheim's sense as

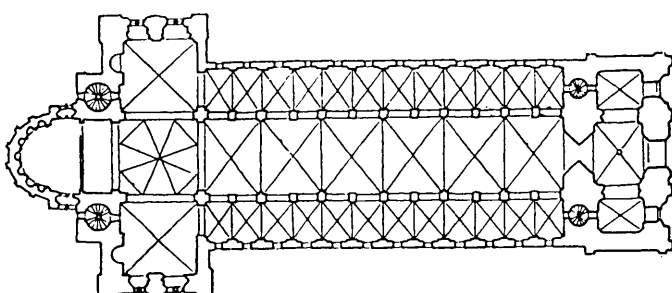

SPEYER. DÓM
(XI. sz.)

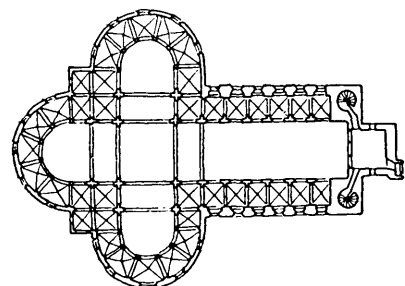

KÖLN. HL. MARIA IM KAPITOL
(XI. sz.)

the building as the organiser of human activity proves fruitful.

'In its plan a building reveals itself as an instrument for human activity. Accordingly, the plan displays the principal dimension of those buildings, whose main thrust symbolises Human behaviour' (Arnheim, 1977:55).

The iconic plan should embody aspects which bring to recall the condition of being human. That this is possible can only be accepted if Arnheim's proposition that the plan has elements which symbolise human behaviour is accepted.

'As the medieval architect laid out the design of a church in which the longitudinal nave was crossed by a shorter transept, he was conscious of creating a building in the image of the cross and of this symbolic shape some of the building's users were certainly aware. But this underlying design is not immediately evident to the person entering the church through its main portal ... The visitor is presented with a linear vista, a path for his pilgrimage to the sanctuary at the altar, ...

Perceived in that way the church is the architectural embodiment of a path, but not really a dwelling place ... Here the transept provides an essential modification. For one thing it transforms the building from a channel into a place because the crossing marks a place.

Mere passage gives way to stable position. A building can be said to become a "place" ... when its basic pattern occupies both horizontal dimensions [that is plan dimensions], not just

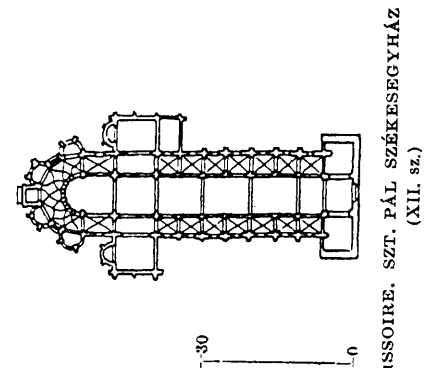
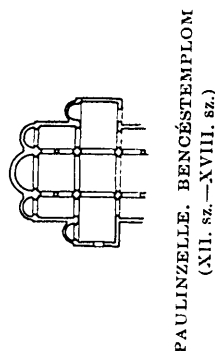
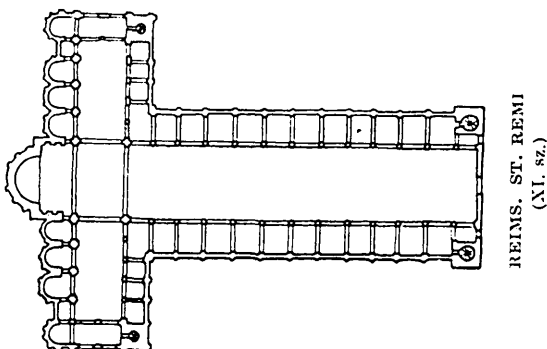

one. The building makes it mark.

The building also establishes a dwelling place for the worshipper on his way to the altar. It creates a second centre, rivalling the first in importance. This ambiguity in the basic arrangement, the presence of two compacting centres [altar and crossing] enables the layout of the Latin cross to function as a highly dynamic image of the meeting of man and God.

Thus the crossing stakes out an architectural place of sufficient weight for the worshipper, and confirms him in his identity before he proceeds further to pay homage at the altar' (Arnheim, 1977:89).

Not only is the point of crossing a 'place' and point of affirmation but also a threshold, a point of transfiguration. Once crossed the worshiper is in the company of God and in the spiritual realm. He should too, in the process, become spiritualised.

The Renaissance switch from the Latin cross to centralised plan (figure 5.25) revealed a changed relationship between man and God. This differs from what is symbolised by central planning of Classical times where gods dwelt amongst men.

'When we consider the historical shift by which the double-centred ambiguity of the Latin cross was collapsed, as it were, into a simple unity of the centralised plan, we may conclude that by the bold coincidence of the two centres, the duality of man and God was being fused into a single power, to the major glory of both' (Arnheim, 1977:91).

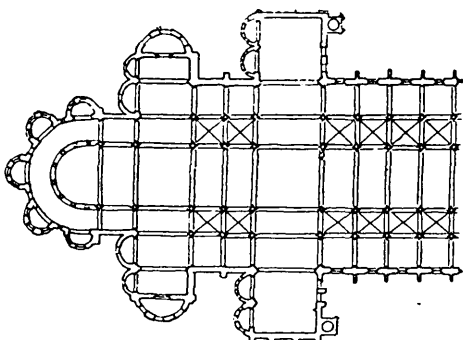

CLUNY. III. TEMPLUM
(1088—1220)

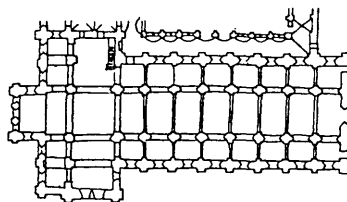

FONTENAY. CISZTERCIJA TEMPLUM
(XII. sz.)

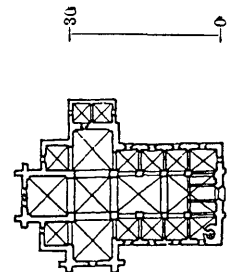

BÉLAFÁTFALVA.
CISZTERCIJA TEMPLUM
(XIII. sz.)

We may also conclude that life was no longer seen as a path of redemption and that man had no longer to cross a threshold into God's presence. Man and God were equally about each others work at all times.

From the preceding can be deduced that the iconic plan is analogous to human activity and in organising that activity reinforces the understanding of the human condition.

5.18 THE REPRODUCED PLAN

Since the plan image can embody abstract aspects of place and path, as well as archetypal forms, and since abstract aspects of the discipline such as the articulation of components or spacial disposition of elements can be read from the plan, it is not necessary to have those plan artefacts required for iconographic interpretation in order to achieve iconological understanding. Hence the reconstructed plans of archaeologists or reproduced plans of the media are valuable sources for iconological interpretation.

5.19 SUMMARY

The plan as image has been shown to have various meaningful aspects namely:

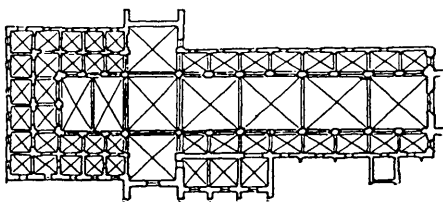

RIDDAGSHAUSEN.
 CISTERCIATA TEMPLUM
 (XIII. sz.)

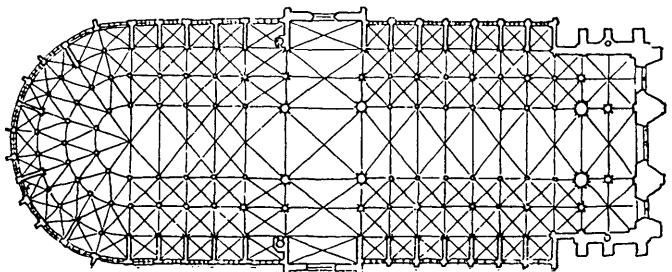

PÁRIZS. NOTRE DAME
 (1163—1320 — J. de Chelles ;
 P. de Montereau ; P. de Chelles műve)

- phenomenological discovery
- perceptual recall
- homospacial display
- place and path
- type
- archetypal association
- narrative
- space-force fields

The plan can also be interpreted at higher levels in the visual hierarchy:

- as sign its function can be represented by its form, for instance Ledoux' 'Oikema'.
- as symbol its associations can be recalled through employment of typical imagery, for instance the theatre as building type.
- as icon it can symbolise the analogous activity of man's associated enterprise, for instance the Christian church as icon of the Christian life.

These abstract elements of plan style can be read just as readily from reconstructed or reproduced plans as from the original plan artefacts.

5.20 CONCLUSION

The fourth subproblem was "to identify which aspects of

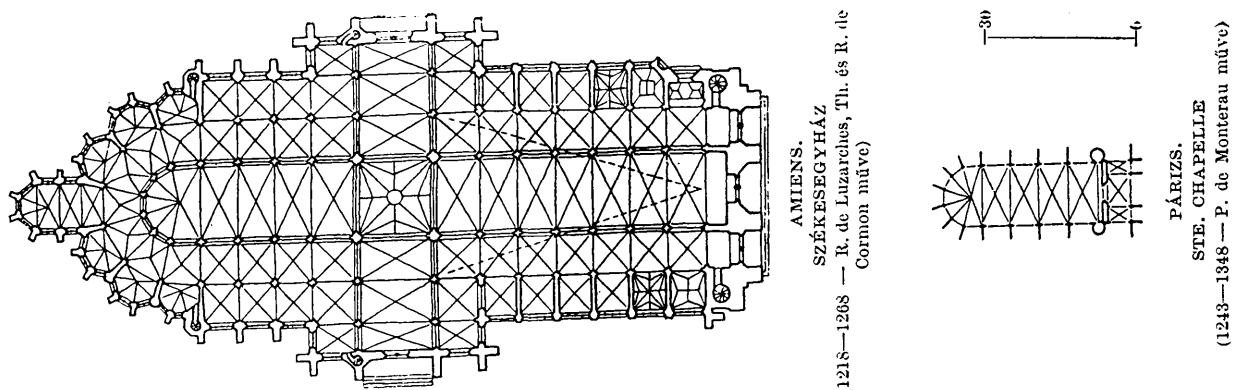

the plan as image can be iconologically interpreted".

The fourth hypothesis was "that the plan-image matches the hierarchy of visual recall, namely: image, sign, symbol and icon".

In being able to present a meaningful discussion the hypothesis is supported.

The plan, both as original or reconstructed or reproduced artefact, is a valuable source for iconological interpretation.

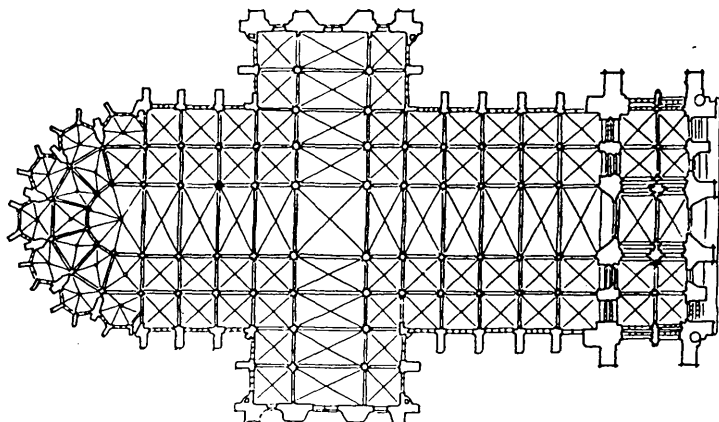

KÖLN. DÓM
(XIII–XIV, XIX. sz. — Gerhard, Arnold,
Johann és más mesterek műve)

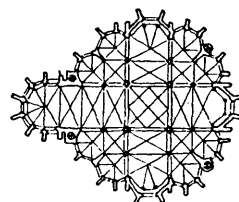

TRIÉR.
MIASSZONYUNK TEMPLOMA
(1242–1253)

CHAPTER 6

THE TRADITIVE PLAN

6.1 SUBPROBLEM 5

The fifth subproblem is the demonstration of the continuity of architectural type through the genealogy of plan images.

6.2 HYPOTHESIS 5

The fifth hypothesis is that the plan can evolve in a traditive manner.

6.3 OUTLINE OF CHAPTER 6

In Chapter 6 the sense of artefactual type as pertains to the discipline of architecture will be determined. A plan type, specifically that of the 'country house' will be presented and its development discussed and illustrated by relevant examples. In the discussion meaning will be given to the evolutionary pattern.

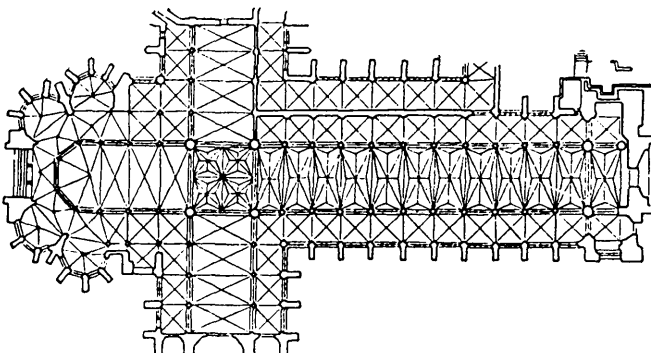

LONDON,
WESTMINSTER-APÁTSÁGI TEMPLOM
(1245—1269)

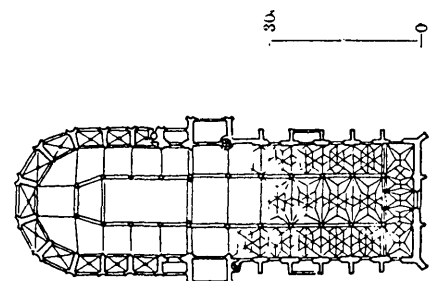

SCHWÄBISCH GMÜND,
SZT. KERESZT TEMPLOMA
(1351 — Heinrich és más mesterek műve)

6.4 INTRODUCTION

If it is acknowledged that the Modern imagination emerges in the C18 (Collins,1965), then the house as vehicle of architectural pursuit must be seen as a Modern concern. Why is this so? The dogmas of the equality of man and the opportunity of progress beyond the station of one's birth plus the propagation of the democratic ideal, places the well-being of the individual as central to all concerns. Hence the home of the common man and his place of work were the primary architectural endeavours. Whereas the application of these dogmas should devolve to a standardised solution, the synchronous discovery of the diversity of individual experience and emotional response led to the exploits of the Romantic spirit. This has been the delicate balance of the Modern condition - the universalising of the rational solution and the giving of expression to the individual experience.

It is so that the home of the common man was not always given to architectural exploitation. Hence Spengler (1934:120-1) could speak of the dwelling as being a natural and not architectural, manifestation:

'Of all expressions of race, the purest is the House. From the moment when man, becoming sedentary, ceases to be content with mere shelter and builds himself a dwelling, this expression makes its appearance and marks off, within the

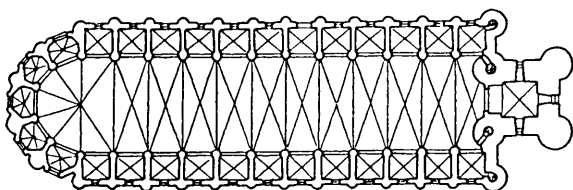

ALBI.
 STE. CÉCILE SZÉKESÉGHÁZ
 (1282—1390)

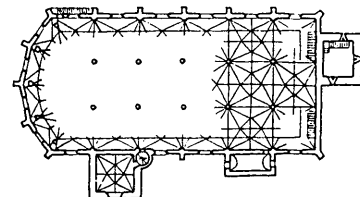

SCHNEEBERG.
 ST. WOLFGANG-TEMPLOM
 (1515—1540)

race "man" (which is the element of the biological world-picture) the human races of world-history proper, which are streams of being of far greater spiritual significance. The prime form of the house is everywhere a product of feeling and of growth, never at all of knowledge.

. . .

This domain art-history ought never to have laid its hand on. It was an error to treat the building of the dwelling-house as a branch of the art of architecture. It is a form that arises in the obscure courses of being and not for the eye that looks for forms in the light; no room-scheme of the boor's hovel was ever thought out by an architect as the scheme of a cathedral was thought out'.

Even in the time when architecture flourished under patronage the architect's own home remained architecturally anonymous. Do we for instance readily recognise the home of Michelangelo Buonarroti?

The home which the architect designs and builds for himself is revealing because of the intimate personal involvement at all levels of execution. Much as in the world of recorded music, the composer, when conductor of his own score, is seen to present the definitive performance, so too the definitive architecture of the architect is often his own home.

The rise of the importance of the individual in the Modern time and the symbolical significance of his home presents the opportunity to examine the inter-relationship of the published plan and search for

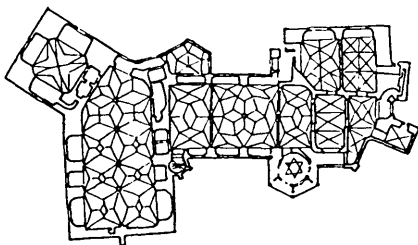

MEISSEN
 ALBRECHTSBURG. VÁRKASTÉLY
 (1471—1481, 1520—1534)

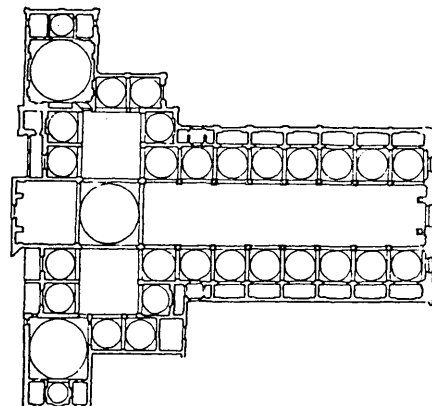

FIRENZE. S. LORENZO
 (1421 — F. Brunelleschi mífve)

Opp. 77

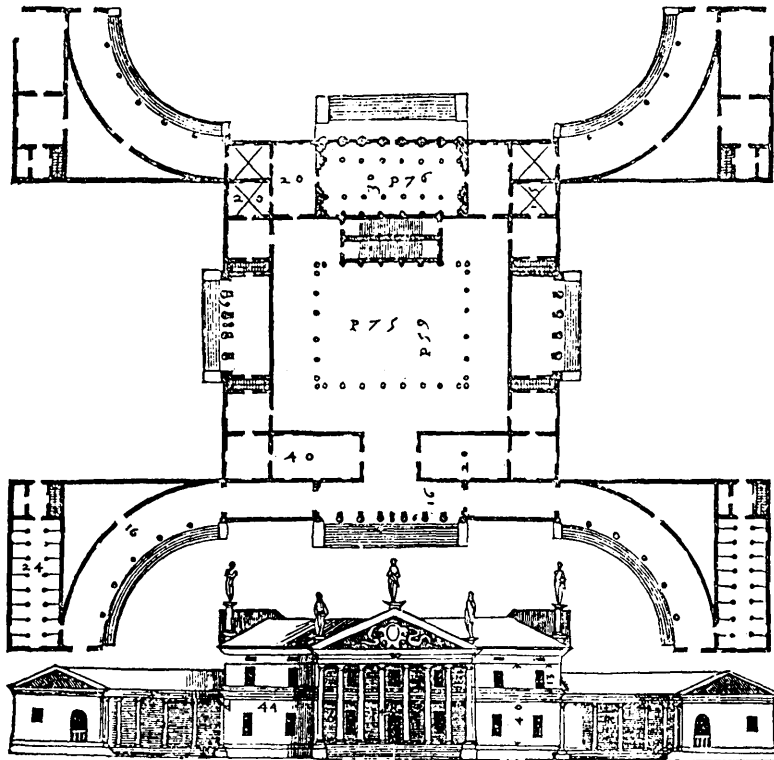

FIGURE 6.1 Villa Moncenigo, Palladio.

a possible evolution in plan image and plan-manipulation. If discovered this will reveal a genealogy, an ongoing line of inheritance. The plan image could be said to play a traditive rôle in the development of the type, specifically the country home.

6.5 ENGLISH PALLADIANISM

The plan as artefact gained relevance and importance in the printing era. The most enduring of such examples are the plans published by Palladio. These became the first pattern-books for the landed English gentry looking for a style which would symbolise the democratic ideal and their parliamentary importance (Wittkower, 1974).

The plan type which is to be investigated is the country house with central core and arms extended into the landscape. The type derives from Palladio's Villa Moncenigo (figure 6.1) a commission believed to have been published without being built, or only partially constructed (Puppi, 1975:358-9) since Jones refers to it in his annotated copy:

'This villa is otherwis ordered for I saww yt and yt is les and as I remember hath thes circular logges. I haue summ nott of yt in my Papars' (Jones, 1970a:78; 1970b:33).

The debate as to whether what Jones saw and recorded

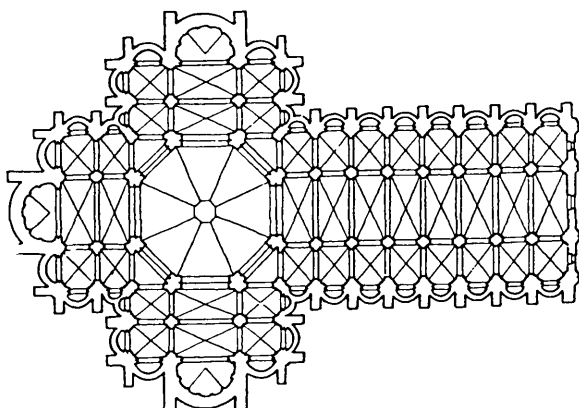

PAVIA. DÓM
(1487 — C. Rocchi műve)

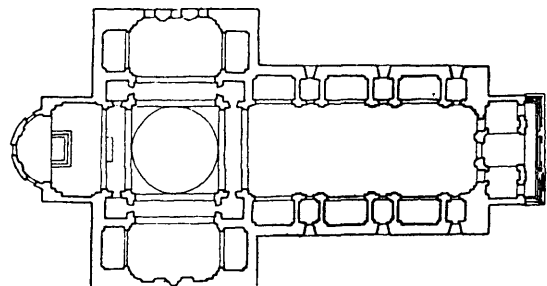

MANTOVA. S. ANDREA
(1470—1494 — L. B. Alberti műve.
A barokk korban kupolával és keresztázzal
bővítve)

30
0

Opp. 78

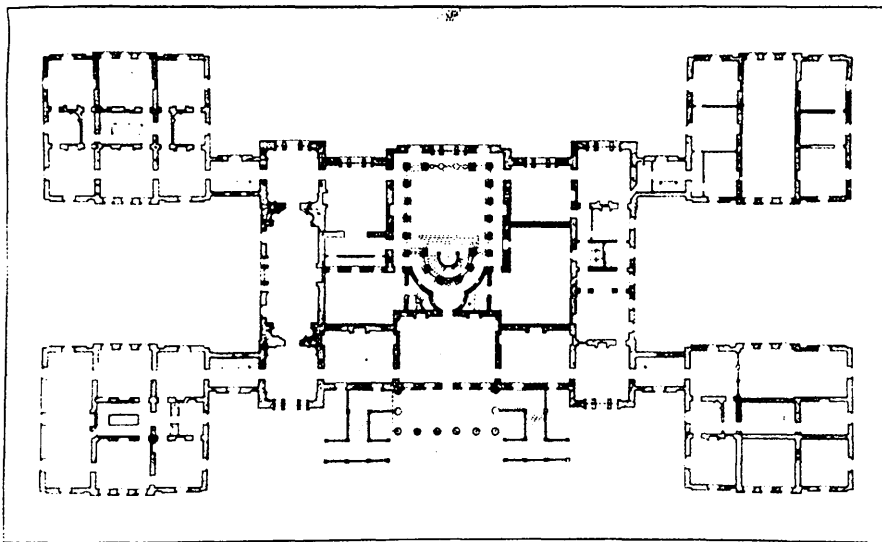

FIGURE 6.2 Holkam Hall (1734-), Kent and Burlington.

is the pertinent Villa is of no consequence to this discussion. What is of interest is that the Villa derives both from the reconstruction of Vitruvius' 'house of the Ancients' and Palladio's design of the Villa Thiene at Cicogna (Puppi, 1975:359).

Lord Burlington through his protégé William Kent influenced the course of English domestic architecture by turning to Classical and Palladian precedent for inspiration in their commissions. Holkam, seat of Lord Leicester, shows the plan type under discussion (figure 6.2). Although drawn by Kent, Wittkower (1974:122-4) sees Burlington's influence through Palladian interpretation. Elements were taken almost verbatim from Pallazzo Thiene '... the most beautiful modern building in the world...' (Burlington in Wittkower, 1974:124). Yet the authorship of this Palazzo is in dispute and 'that Scamozzi's responsibility is to be considered preponderant and decisive, [although] the name of Palladio is justified by the recollection of Pallazzo Barbarans...' (Puppi, 1975:403). We are however not interested in stylistic alliance but plan type and the Palladian Villa is most certainly precedent to the C18 English country home.

6.6 FROM PALLADIANISM TO PICTURESQUE

The C18 Palladian tradition in building country residences in England was superseded by the

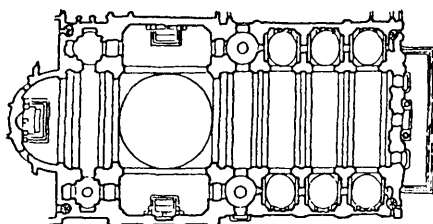

RÓMA. IL GESÙ
 (1568—1684
 J. B. da Vignola, G. d. Porta műve)

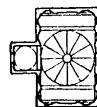

FIRENZE.
 CAP. DEI PAZZI
 (1430—1443 — F. Brunelleschi műve)

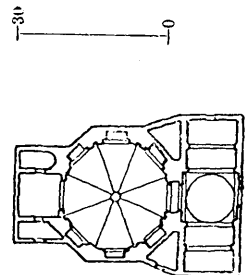

PISTOIA. MADONNA DELL'UMILTA
 (1494 — V. Vittoni műve)

Opp. 79

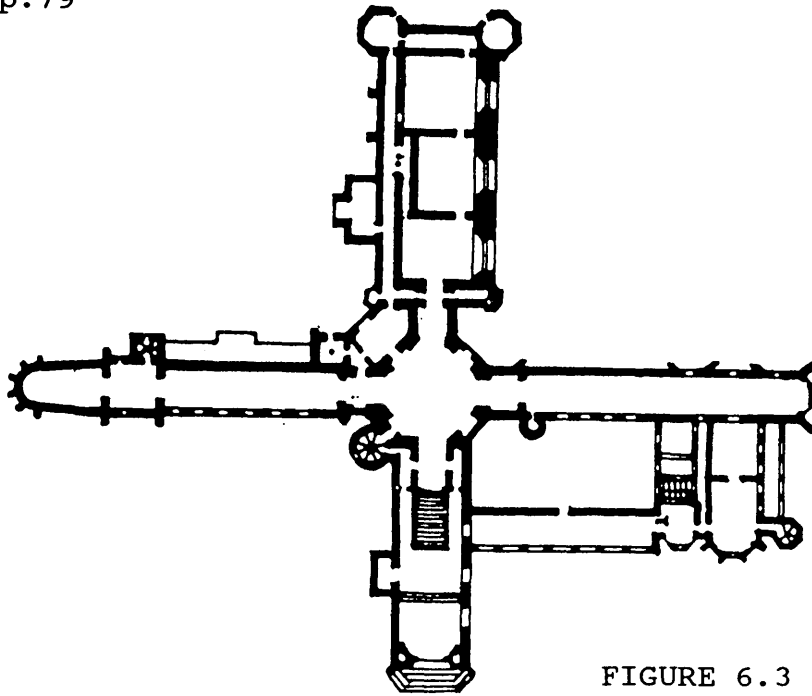

FIGURE 6.3

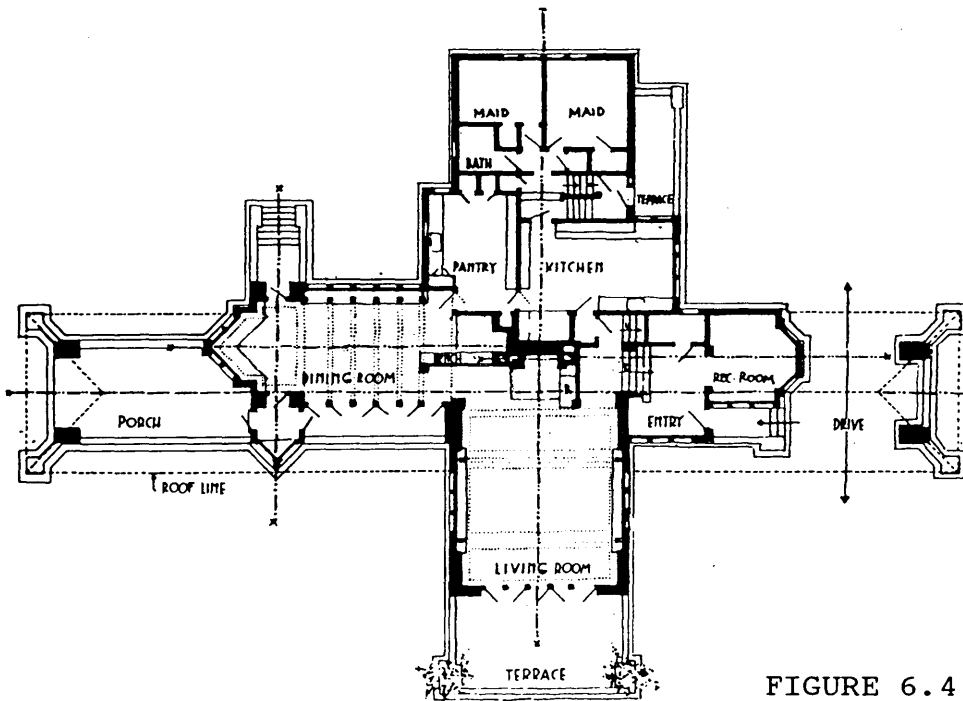

FIGURE 6.4

FIGURE 6.3 Fonthill Abbey (1796-), Beckford.

FIGURE 6.4 Ward Willits House (1904-), Frank Lloyd Wright.

Picturesque homestead. Beckford's Fonthill Abbey provides the perfect example, possibly because of the extravagance of conception, possibly the eccentricity of its owner or the romance of association following its ruination in a storm in 1825 after the spectacular collapse of its octagonal tower.

The ideals of the Picturesque school of thought were the 'elegant prospect' and the planned happenstance. A longing backward-glance was cast upon the Middle-Ages and an attempt made to recapture the happiness of the craftsman engaged in his labours. What results is a concatenated asymmetrical disposition of rooms to create a sense of accidental arrangement and intuitive planning, with exaggerated attenuations to invoke the sublime, all styled in the 'Gothick' manner (figure 6.3).

6.7 FROM PICTURESQUE TO PRAIRIE STYLE

In 1910 Wasmuth published 'Ausgefuehrte Bauten und Entwuerfe von Frank Lloyd Wright'. To ease its way into German acceptance, Frank Lloyd Wright had the English Arts & Crafts architect Charles Ashbee preface the monograph since both the movement and architect had a sympathetic German following. The portfolio featured amongst other, the Ward Willits house, Highlands Park, Illinois (figure 6.4). This Arts and Crafts reinterpretation is progeny to the Picturesque grand-daddy and probably served as inspiration to Mies' country home.



RÓMA. TEMPIETTO
(1502 — Bramante múve)

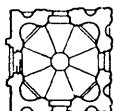

RÓMA.
STA. MARIA DI LORETO
(1507 — ifj. A. da Sangallo, G. del Duca múve)

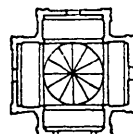

PRÁTO.
MADONNA DELLE CARCERI
(1485—1491 — G. da Sangallo múve)

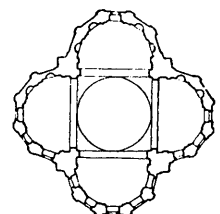

TODI.
STA. MARIA DELLA CONSOLAZIONE
(1508—1524 — D. Bramante múve)

Opp. 80

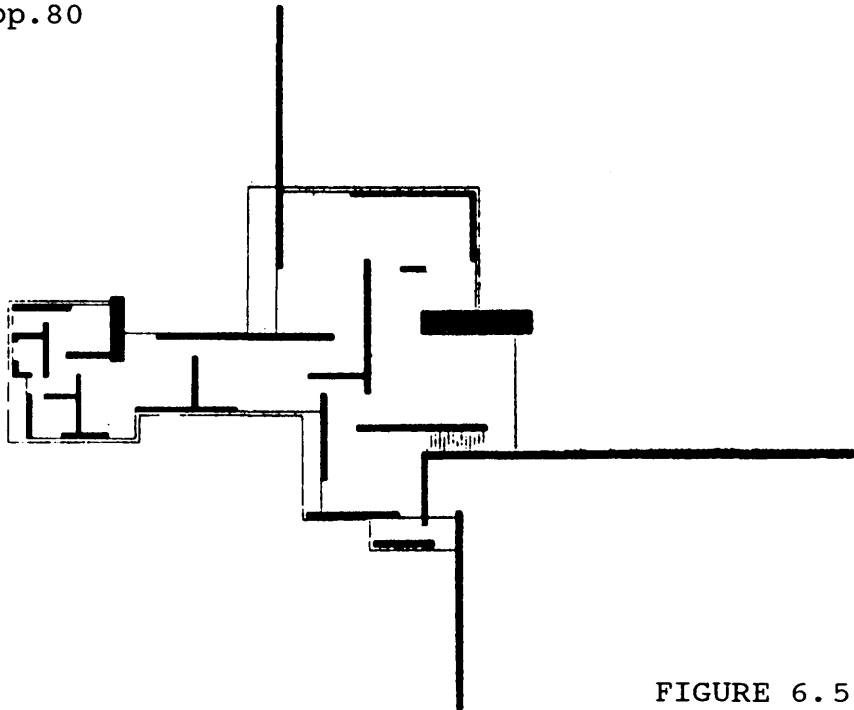

FIGURE 6.5

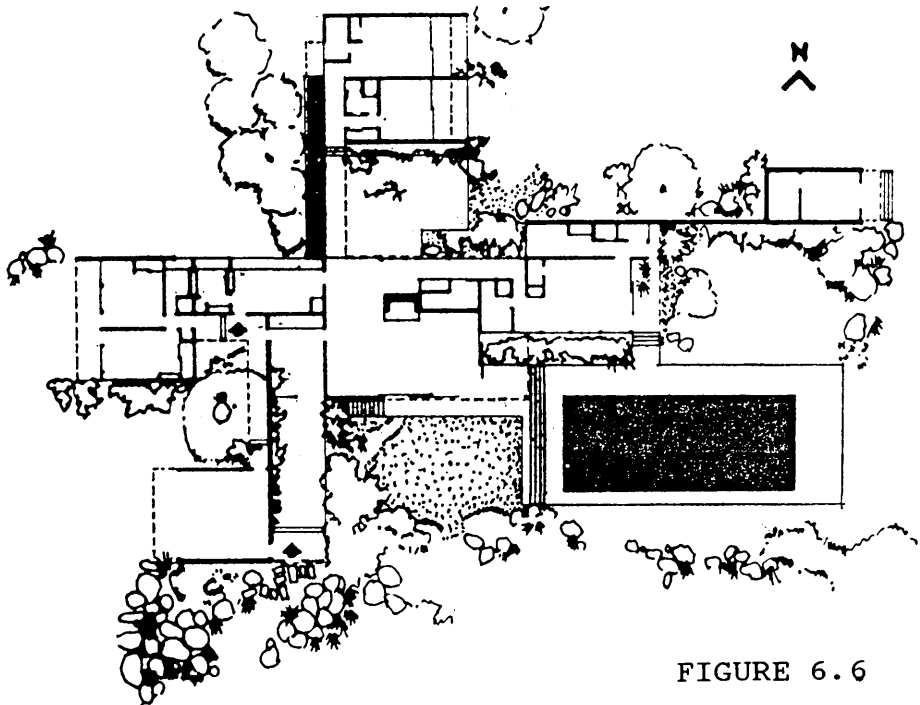

FIGURE 6.6

FIGURE 6.5 A Country Home (1923), Mies van der Rohe.

FIGURE 6.6 House Kaufman (1946-), Richard Neutra.

6.8 THE DEMISE OF TRADITION

In the fashion of the reactionist passion which typifies the C20 the De Stijl movement emerged as snuffer to the intuitions of the Romantic spirit. Extreme in the reductionism, a scheme of provocatively arranged cuboids hovering in space was generated. This conceptualisation became literally concretised by the architecture of the new technologies of structural steel and ferro-concrete. Mies van der Rohe's design for a country home of 1923, generated from the pin-wheel conception of Gropius' Bauhaus plan embodies these abstractions, although conceived in brick (figure 6.5). It has remained the potent emblem for all subsequent Modernists approaching the problem of the country residence. This plan attempts the bringing to domestic architecture the abstract plasticism of the De Stijl movement through the moulding of the fabric. In the disposition of the plan it is however progeny of the Picturesque School via that of the Arts and Crafts.

House Kaufman in the Colorado Desert of 1946 by Richard Neutra (figure 6.6), now abandoned and buried, overtly derives from this cardinal disposition of rooms about a pivotal centre. More expansive than the projected country house of Mies, it still retains the strict orthogonal geometry of the De Stijl ilk.

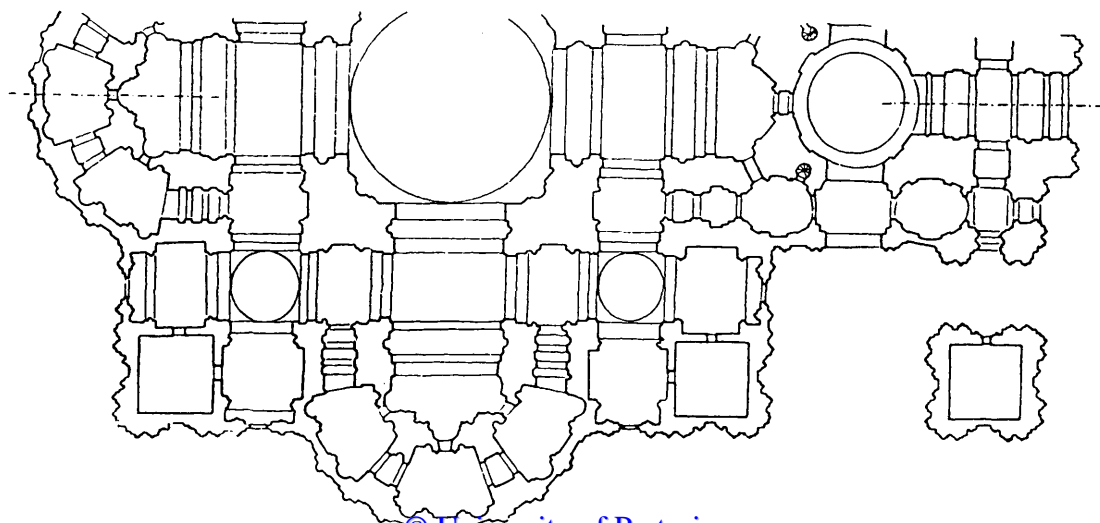

RÓMA. S. PIETRO
(XVI. sz. eleje — G. da Sangallo terve)

Opp. 81

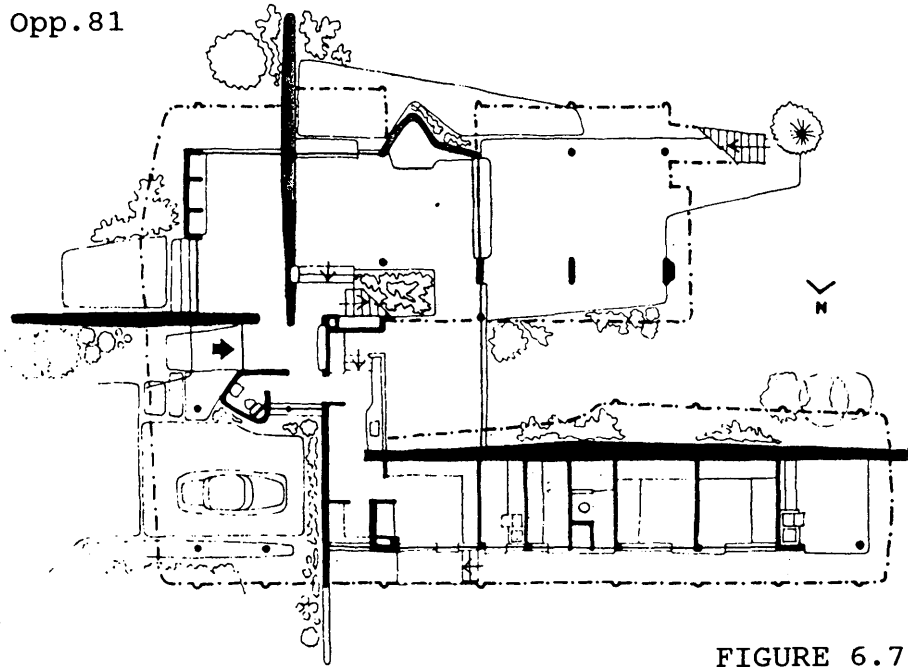

FIGURE 6.7

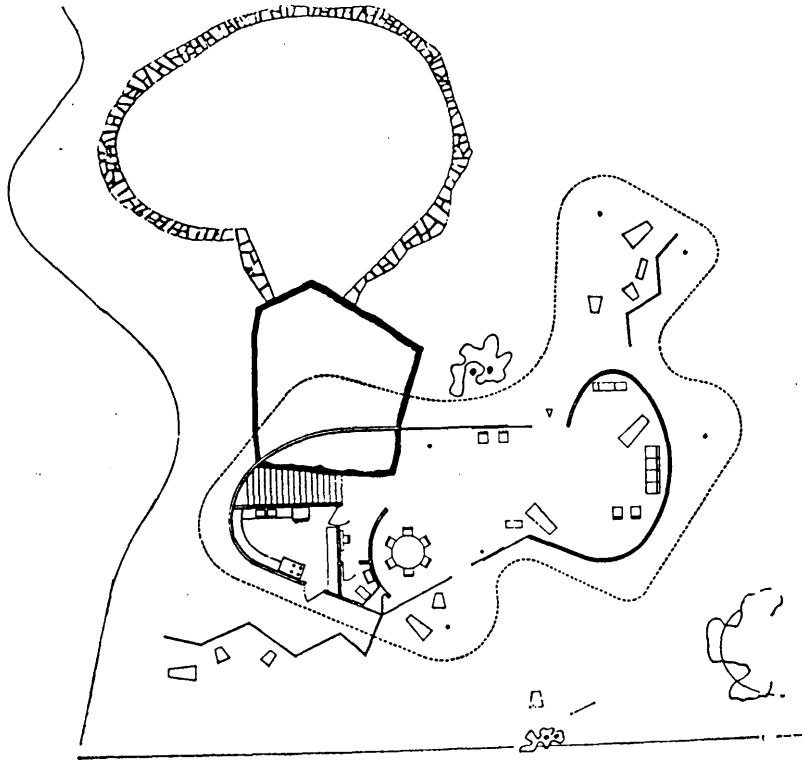

FIGURE 6.8

FIGURE 6.7 Martins House (1953-), Amancio d' Alpoim Guedes.

FIGURE 6.8 Niemeyer House (1953-), Oscar Niemeyer.

6.9 FROM TABULA RASA TO REGIONALIST REACTIONS

Amancio Guedes, in his Martins House, Lourenco Marques (1953) appropriates the image of Mies' Country home but puts it to his own devices (figure 6.7).

It is he who demonstrates the liberation of the elemental masses from the geometry of the straight line. Though still adhering to the cardinal disposition of rooms, the elements swell and grow about the pin-wheel core. Beinart, critic of the *Architectural Review* (1961:248), discerned influences descending from Iberian Baroque and the Art Nouveau of Gaudi. 'His work is characteristic of those extravagant tendencies to be found in the Southern extremities of Latin Europe' (Cantacuzino, 1970:152).

As far as the interpretation of this plan is concerned the commentator is mistaken. The Baroque, even in its most sinuous curves, is still regulated by complex geometry derived from the Renaissance. Art Nouveau abandons orthogonal geometry in the plan, yet the planning still derives in the main from straight-line geometry and it is only in the section and elevation that we discover the self-conscious exploration of the free line. Yet in being mistaken the critic proves the point at issue. He recognises the departure from the geometries of Modernism but incorrectly ascribes their origins.

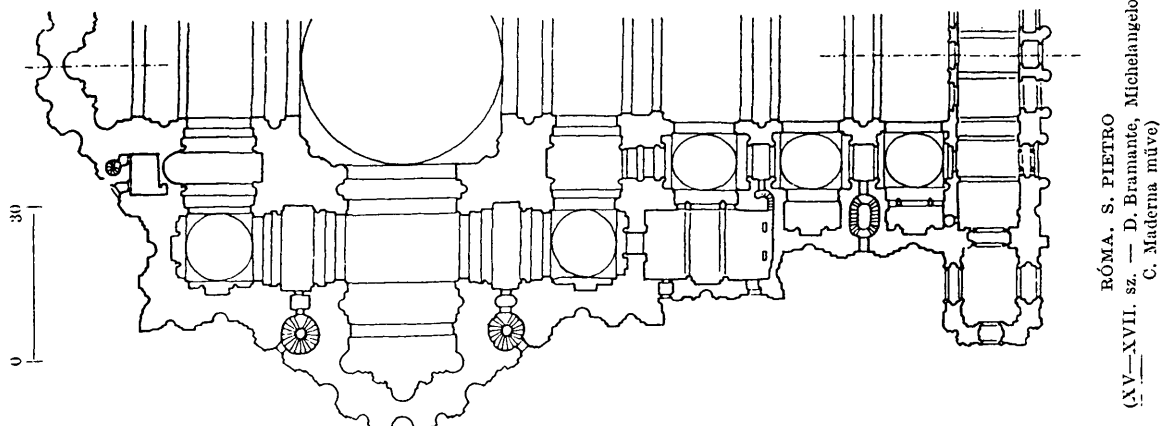

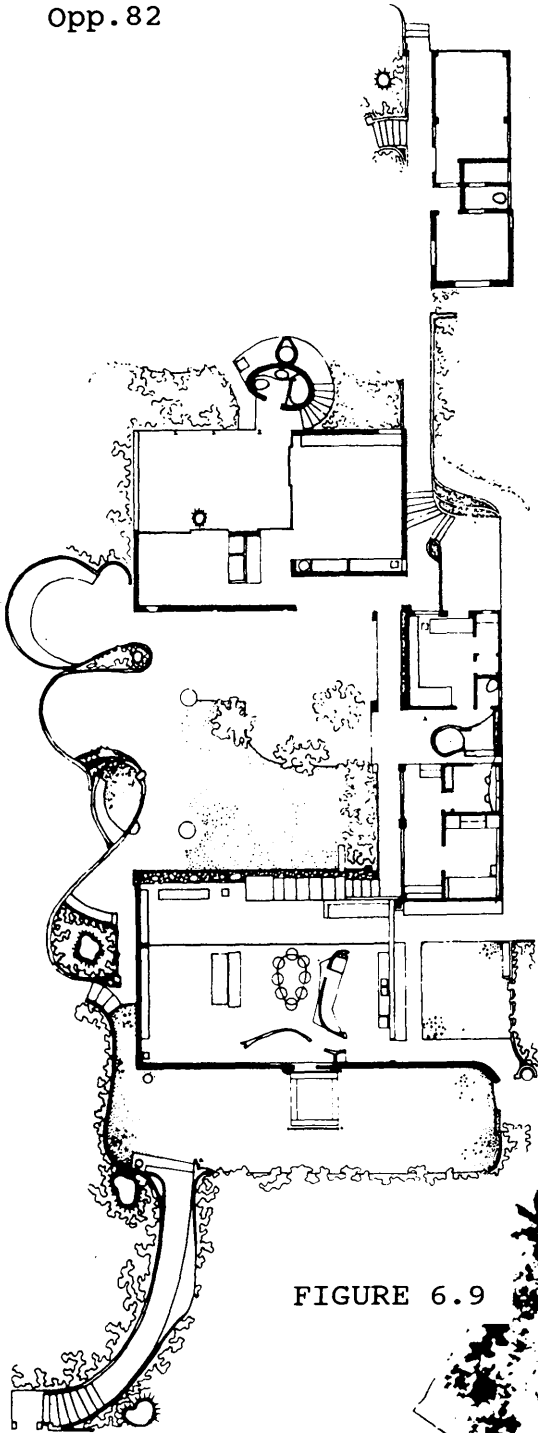

FIGURE 6.9

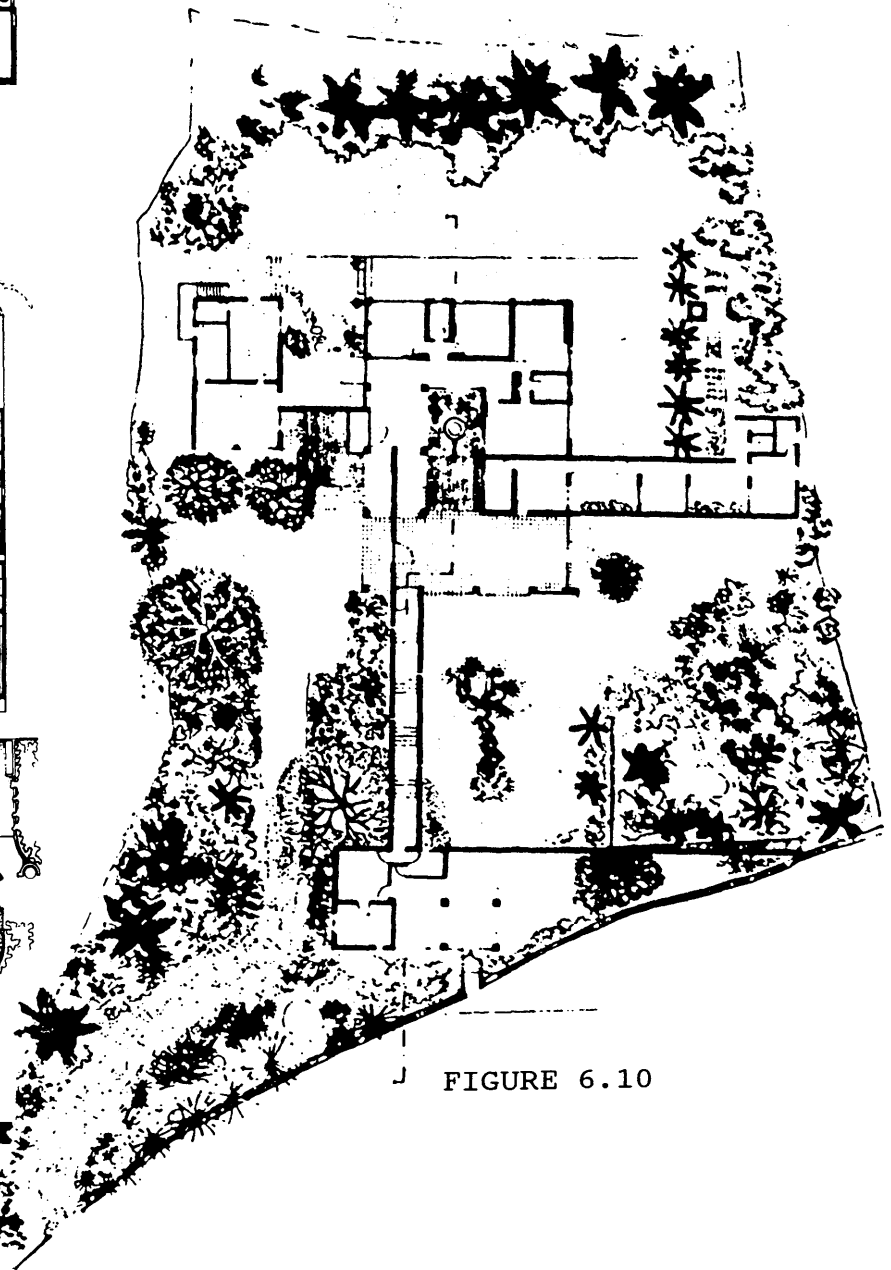

FIGURE 6.10

FIGURE 6.9 House Biermann (1961-), Barrie Biermann.

FIGURE 6.10 De Silva House (1961-), Geoffrey Bawa.

The intuitive line is the "line of beauty" which Hogarth propagated as deriving from nature. Its use by the designer reflects on the giving of expression to his innate inspiration. Hence the intuitive line is the popular tool of the Expressionist, such as the house of Oscar Niemeyer for himself (figure 6.8). The use of the intuitive line can therefore only be traced to precedent but has no genealogy. Each time it is employed it is rediscovered. This insinuation of the intuitive line into the emblem of the plan within the rational world of Modernism is discovered in the Guedes plan.

6.10 TWO CONTEMPORANEOUS INTERPRETATIONS

It is of interest to compare the two contemporary house plans, that of Barrie Biermann (figure 6.9) with that of Geoffrey Bawa (figure 6.10). Both have hollowed the hearth areas into a tranquil courtyard, a cool heart within a humid climate. Both have the roof as a single linking element following the slope of the terrain. Bawa is still progeny to the forefather with arms extending into the landscape. These are reduced to amputated appendages in the Biermann opus, emphasising the withdrawing and defensive nature of the home. The intuitive line tentatively introduced by Guedes becomes the contrapunctal theme of the Biermann home giving expression to the free spirit of the man, though still strictly disciplined by the rational geometries of its forebears. The Biermann plan is like

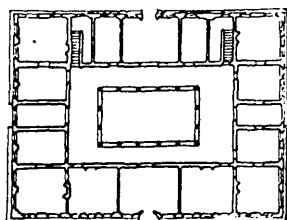

FIRENZE. PAL. STROZZI
 (1489 — B. da Majano és S. Cronaca m. úvc)

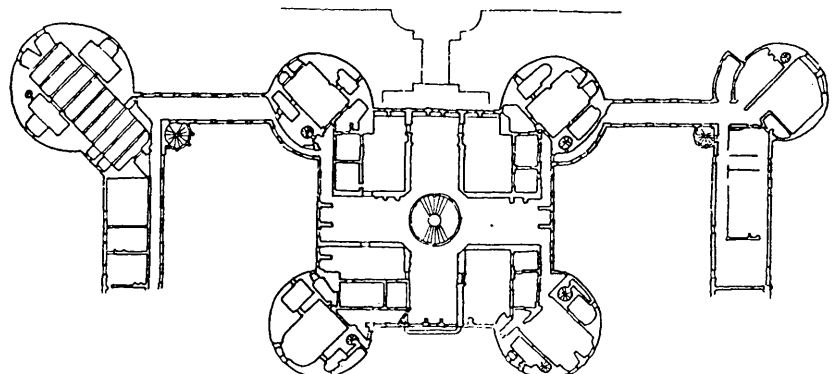

CHAMBORD VÁRA (részlet)
 (1526 — P. Nepveu műve)

the musical compositions of the Brazilian composer Heitor Villa Lobos. While accepting the abstract formalities of the Old World it brings to them the exotic sonorities of the New World. If Guedes is the Iberian spirit luxuriating in subtropical climes, Biermann's is the Northern rational mind finding liberation in the intuitions of Africa.

6.11 SUMMARY

A pedigree of the free plan, centred around a core and extending into the landscape has been set out.

In our exploration we have seen that the plan as emblem may be propagated through time in terms of its 'memetic' content, but that the individual will bring to the pattern schema of his own. These derive just as readily from the rational as from the intuitive mind. The potency for perpetuation through time of the individual contribution is dependent on the clarity and dissemination of the plan image. This can thereafter be investigated, reinterpreted and elaborated. It becomes part of the currency of exchange of the discipline. Whereas the rational component of the plan can be perpetuated and modified, the intuitive component has every time to be rediscovered and re-explored.

6.12 CONCLUSION

The fifth subproblem was "the demonstration of the

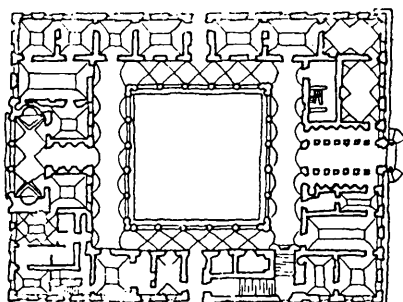

RÓMA.
 PAL. FARNESE
 (1514—1589)
 (fj. A. da Sangallo, Michelangelo,
 G. della Porta műve)

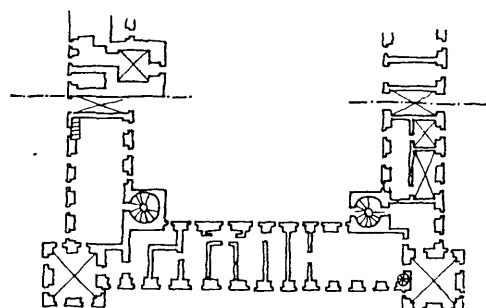

ASCHAFFENBURG.
 VÁRKASTÉLY
 (XVI—XVII. sz.)

0 30

continuity of architectural type through the genealogy of plan images".

The fifth hypothesis was "that the plan can evolve in a traditive manner".

It has been discovered that the Palladian English country house, as emblem of the propertied and enfranchised individual, has been popularised through the medium of publication and has undergone stylistic metamorphosis in its redeployment. The plan image can thus be said to have played a traditive rôle in the development of the country residence. The hypothesis, through illustration, is supported.

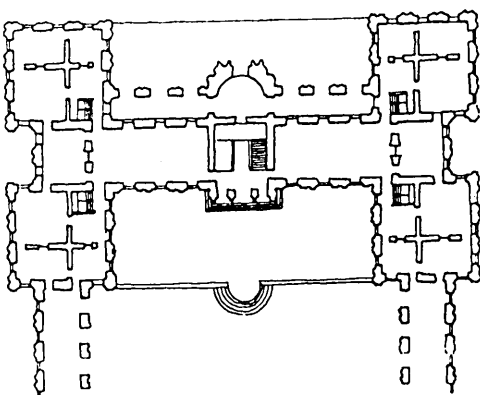

PÁRIZS. PAL. LUXEMBOURG
(1615—1620 — S. de Brosse műve)

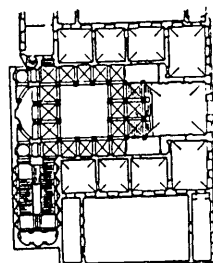

GENOVA. PAL. DURAZZO
(1620 körül, feltételezően B. Bianco műve)

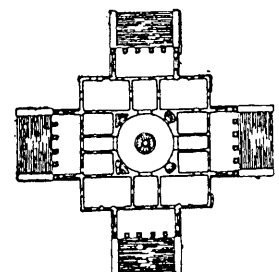

VICENZA. VILLA ROTONDA
(XVI. sz. vége — A. Palladio műve)

CHAPTER 7

THE INTERACTIVE PLAN

7.1 SUBPROBLEM 6

The sixth subproblem is to ally plan styling to episodes of paradigm shift or change.

7.2 HYPOTHESIS 6

The sixth hypothesis is that since the plan is an interactive artefact of its time it can only be iconologically interpreted contextually.

7.3 OUTLINE OF CHAPTER 7

In Chapter 7 a constant plan - the circular plan - and a constant building type - the dwelling - will be explored. Paradigmatic episodes throughout history will be illustrated through the appropriate examples and thereby meaning ascertained.

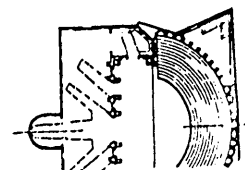
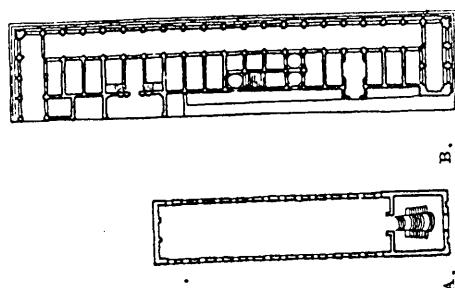
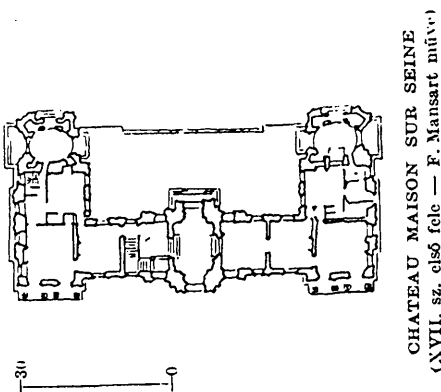

Opp. 86

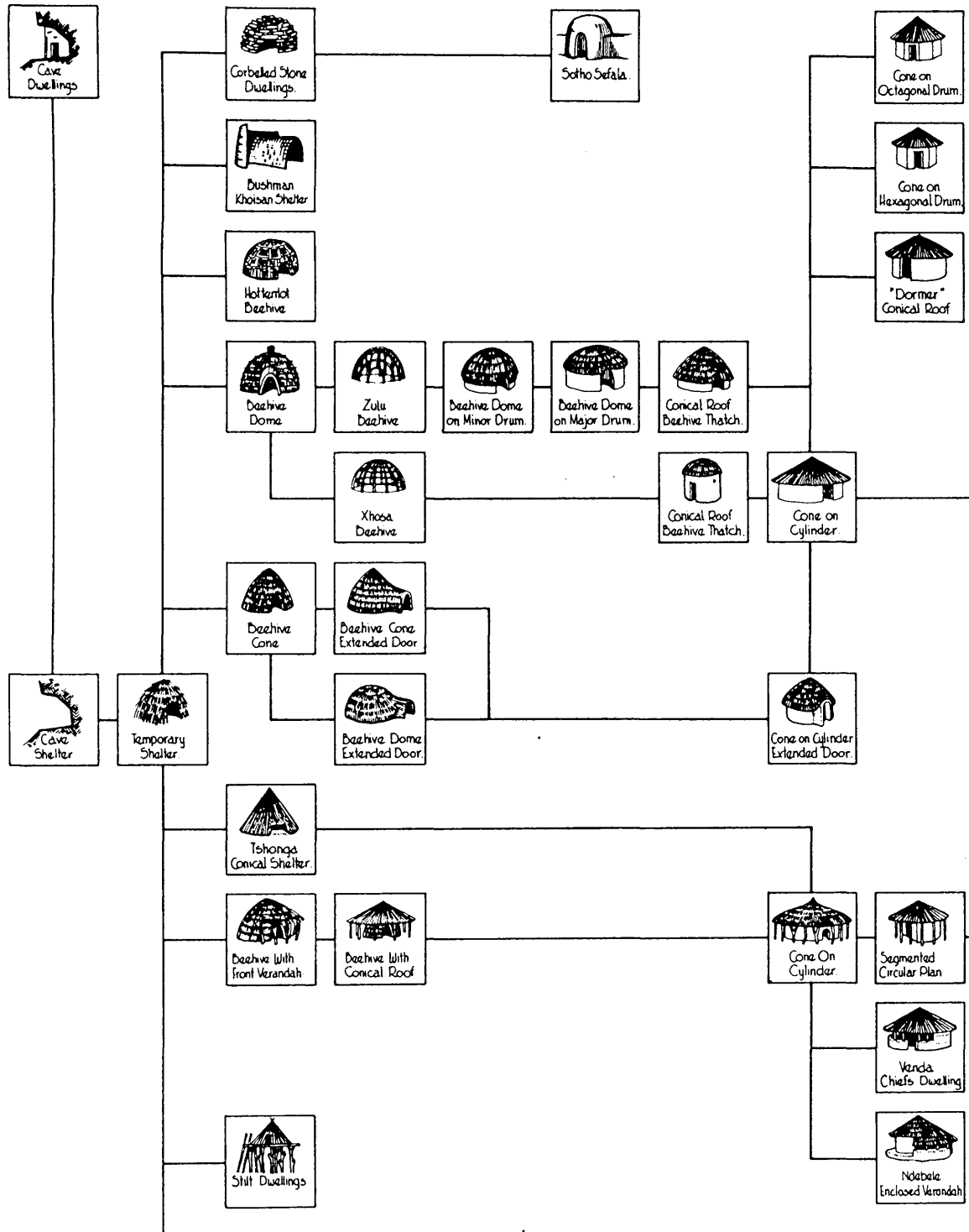

FIGURE 7.1 The evolution of the round hut in Southern Africa.

7.4 INTRODUCTION

The home of man is the oldest building type. In its construction man reveals something of his inherent biological nature and, in its modification through time, his cultural evolution (figure 7.1). Rapoport (1969;46) has identified the following as that which was traditionally seen as generators of house form: climate, materials, site, defence, economics and religion (figure 7.2).

Another determining factor could be added to this list, that of meaning. When meaning becomes style determinant then the form-giving, or styling, can be said to be 'iconic' in that there is a deliberate exploitation of the making of the home to convey more than is required by purely utilitarian consideration. The styling will be more narrowly associated with its time and specifically the time wherein a particular set of beliefs are ascribed to and where a specific cosmic understanding holds sway.

Rapoport (1969:75) has provided the following as three attitudes of man to environment:

- '1. Religious and cosmological. The environment is regarded as dominant, and man is less than nature.
2. Symbiotic. Here man and nature are in a state of balance, and man regards himself as

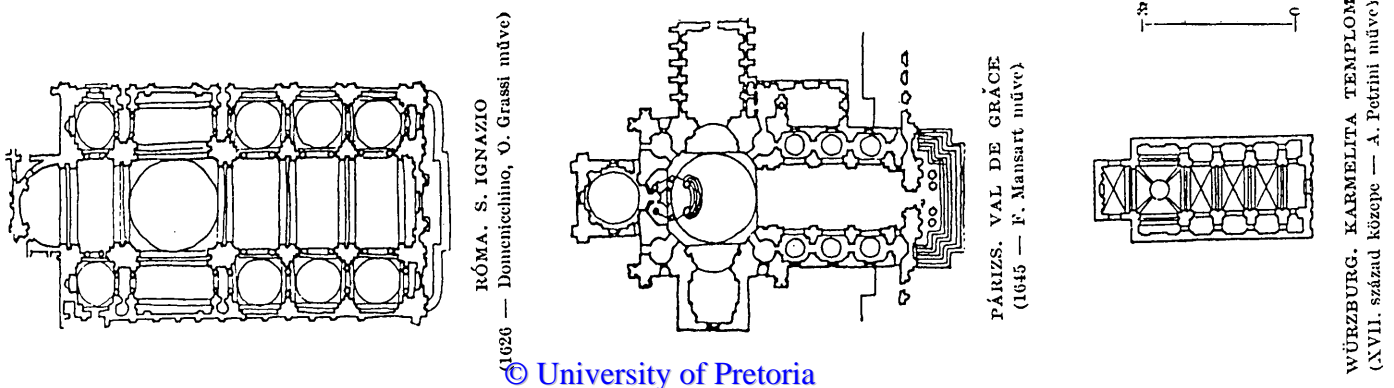

Opp. 87



Rock carvings of huts
from the Alps
2 nd millenium BC

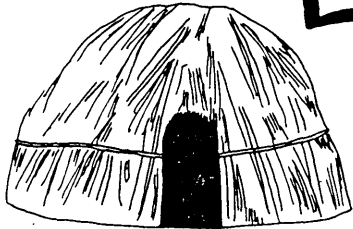

temporary beehive hut
tydelike byekorfhut



Romulus and Remus hut

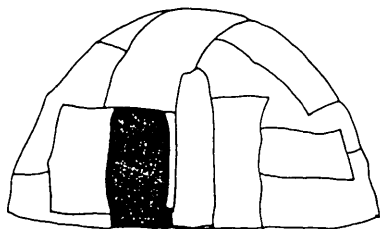

nomadic beehive hut
nomadiese byekorfhut

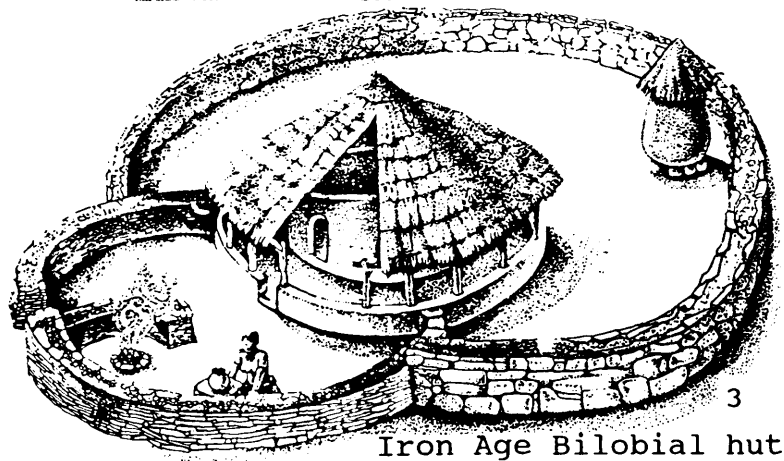

Iron Age Bilobial hut

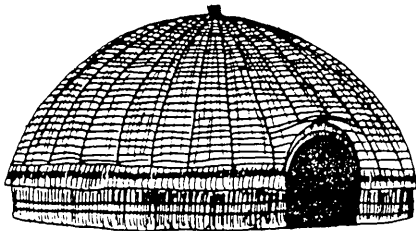

beehive hut
byekorfhut

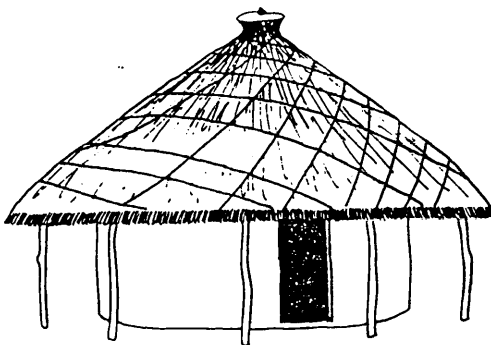

palisaded rondavel hut
ompaalde rondawelhut

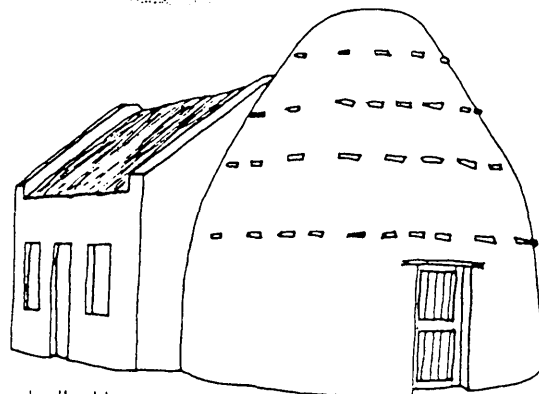

corbelled house
korbeelhuis

FIGURE 7.2

Varieties of round huts from pre-history to the present.

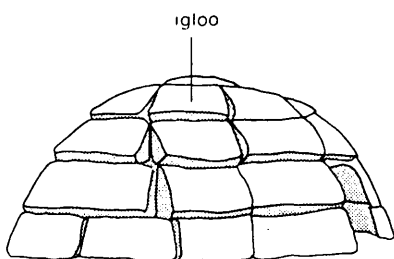

igloo

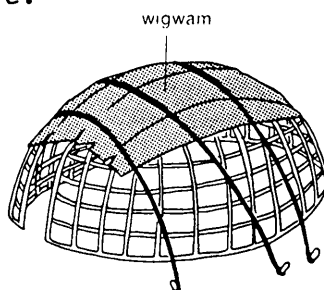

wigwam

5

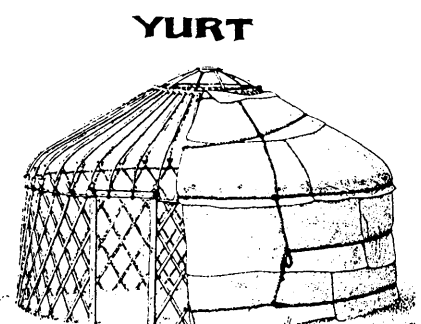

YURT

6

responsible to God for nature and the earth and as a steward and custodian of nature.

3. Exploitative. Man is the completer and modifier of nature, then creator, and finally destroyer of the environment'

These could be more accurately called three paradigms. The third has previously been termed the 'Mechanistic Paradigm' and this will be retained. To them should be added two others, one preceding and one concluding the list:

- Sympathetic-analogous with the musical meaning 'relating to vibrations occurring as a result of similar vibrations in a neighbouring body' (Collins,1979[5]). In this view the world is animist - 'natural objects, phenomena, and the universe possess souls' (Collins,1979[1]), which allows for shamanist practices based on the belief that the world is pervaded by good and evil spirits with whom the Shaman can commune and through whom they can be appeased.
- Ecosystemic - already extensively discussed in Chapter 2.

From this then a chronology of paradigms namely:

- the Symbiotic Paradigm
- the Sympathetic Paradigm
- the Cosmic Paradigm

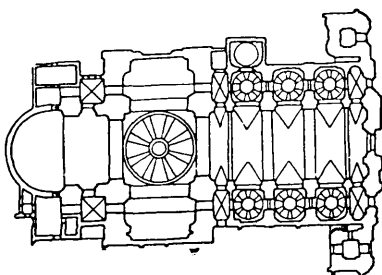

MÜNCHEN.
THEATINUS-TEMPLOM
{ 1679—1768 — A. Barcili, E. Zuccali,
d. F. Cuvilliers müve)

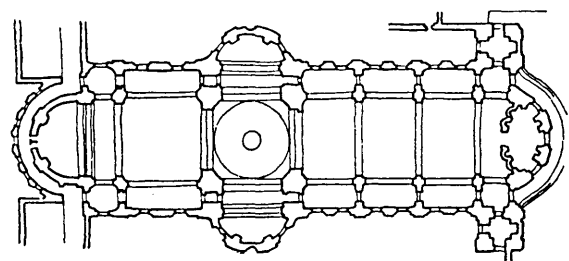

WEINGARTEN. BENCÉS-TEMPLOM
{ 1715—1724 — F. Beer, G. Frisoni müve)

the Mechanistic Paradigm
 the Ecosystemic Paradigm

The acceptance of these as identifiable paradigmatic episodes allows another dimension for interpretation of the house form, namely that of 'socio-cultural forces', considered to be 'primary' by Rapoport (1969:47):

'Buildings and settlements are the visible expression of the relative importance attached to different aspects of life and the varying ways of perceiving reality. The house, the village, and the town express the fact that societies share certain generally accepted goals and life values. The forms of primitive and vernacular buildings are less the result of individual desires than of the aims and desires of the unified group for an ideal environment. They therefore have symbolic values, since symbols serve a culture by making concrete its ideas and feelings. At the same time, house forms, more than other artifacts, are influenced and modified by climatic forces, choice of site, and availability and choice of materials and construction techniques' (Rapoport, 1969:47).

In this chapter the building type, namely the house, is to remain as a constant and the plan form, specifically the circular plan, is to be investigated in order to discover how its exploitation manifests changes in meaning within the time of its making.

7.5 THE SYMPATHETIC HOUSE

The circular dwelling would appear to be the natural

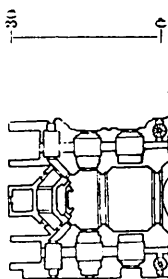

ELK. BENCÉS APÁTSÁGI-TEMPLOM
 (1702—1736 — J. Prandauer műve)

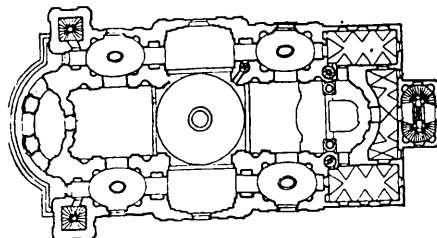

SALZBURG, KOLLÉGIUMI TEMPLON
 (1696—1707 — J. B. Fischer v. Erlach műve)

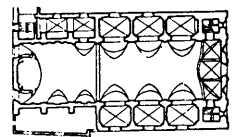

GYÓTR. SZT. IGNÁC TEMPLON
 (XVII. sz. második fele)

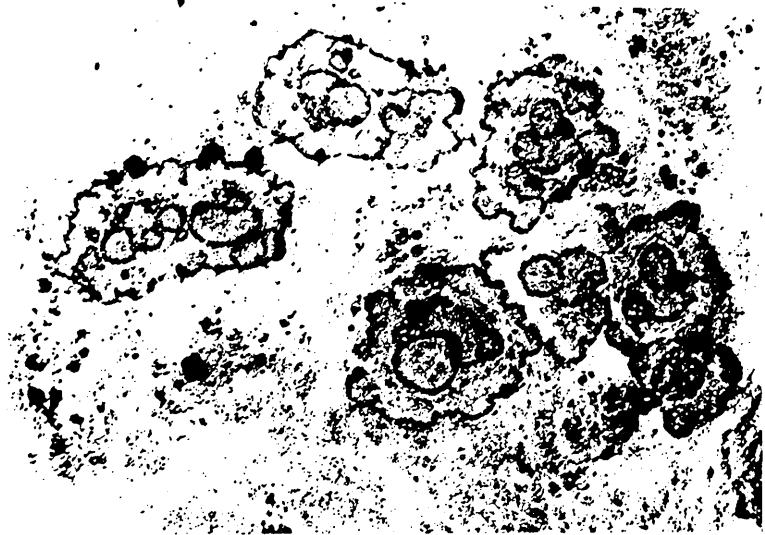

FIGURE 7.3

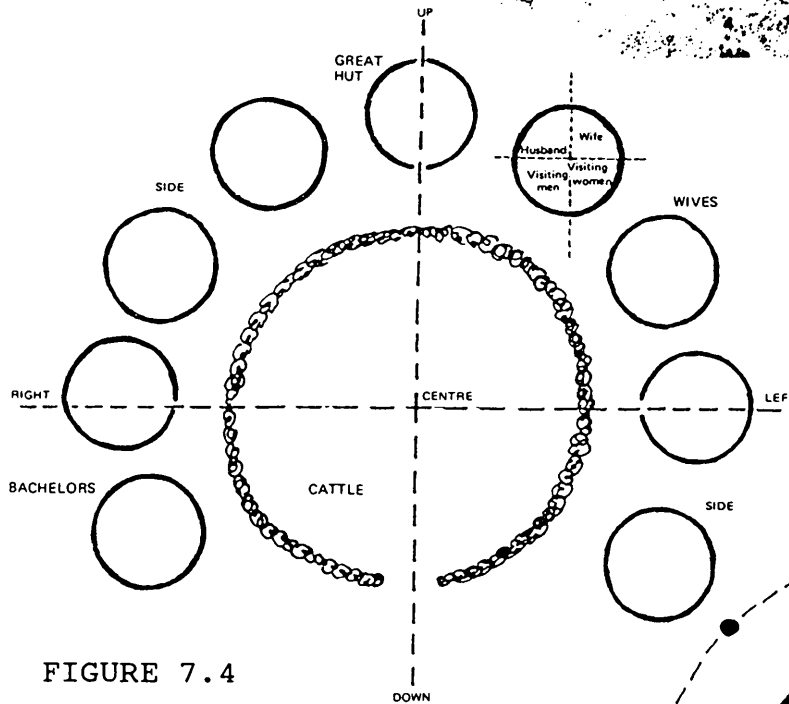

FIGURE 7.4

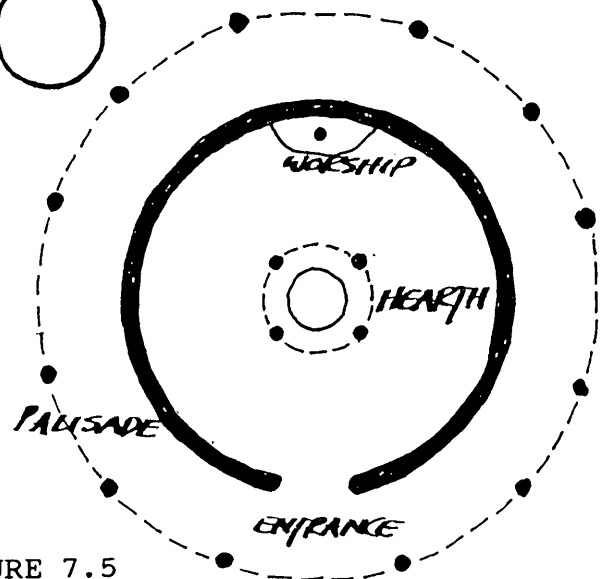

FIGURE 7.5

- FIGURE 7.3 An aerial photograph of an Iron Age settlement at Klipriviersberg.
- FIGURE 7.4 A representation after Kuper of the 'Bantu cattle pattern' showing the symbolic significance of left/right, up/down and centre/side.
- FIGURE 7.5 A reconstructed dwelling, Blantyre Cultural Museum, Malawi showing places of significance.

biological response of man to his environment since the type is found in the extremes of climatic conditions, from the igloo of the Inuit to the temporary twig shelter of the desert-dwelling San. The form would seem to be well associated with the existence of the hunter - gatherer lifestyle where it is accepted that when the resources are depleted then it is time to move on to where the hunting is good and the food abundant or the soil fertile. If Africa is accepted as the home of mankind, then we can first examine the type of dwellings of this continent.

Photographs of a community of such dwellings (figure 7.3) reveal the natural organic layout. Although the circular form is self-focused the dwellings are always related to site and community. The hierarchy which exists in such a community is one of kinship. This finds expression in the disposition of the dwellings. There are no 'empty' or non-utilitarian buildings in such a community and the symbolic component derives from the geographic disposition of elements (figure 7.4). Ancestral worship occurs at the heart of the home. This is the existential significance of the round house (figure 7.5). It concretises the phenomenological understanding of home as cosmic centre, a centre which orientates the occupant as they move away from or towards it in their daily routines.

7.6 THE COSMIC HOUSE

Wherever man wandered in his colonisation of the globe

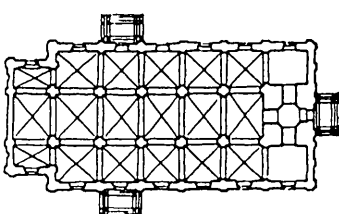

LENINGRÁD.
 PÉTER-PÁL SZÉKESEGYHÁZ
 (XVIII. sz. eleje
 D. Trezzini, J. Usztinov műve)



MARIA LIMBACH
 BÚCSÚJÁRÓ TEMPLOM
 (XVIII. sz. közepe — A. Hassfurt műve)

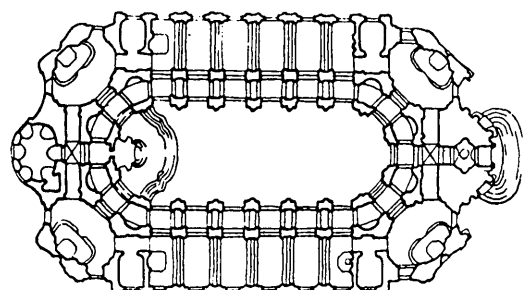

DREZDA.
 KATOLIKUS UDVARI TEMPLOM
 (1738—1751
 G. Chiaveri, Knöfel, Schwarz műve)

Opp. 90

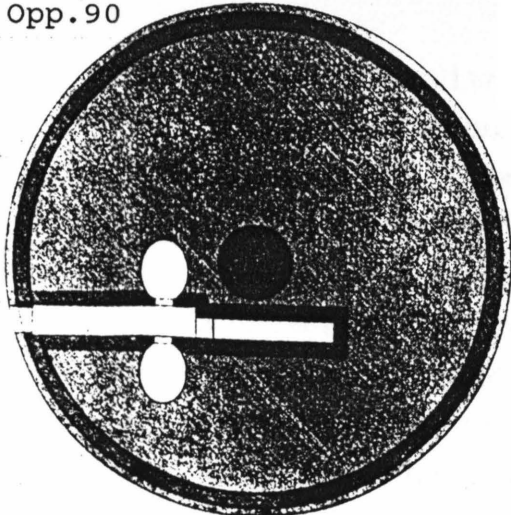

5 10 15 20

FIGURE 7.7

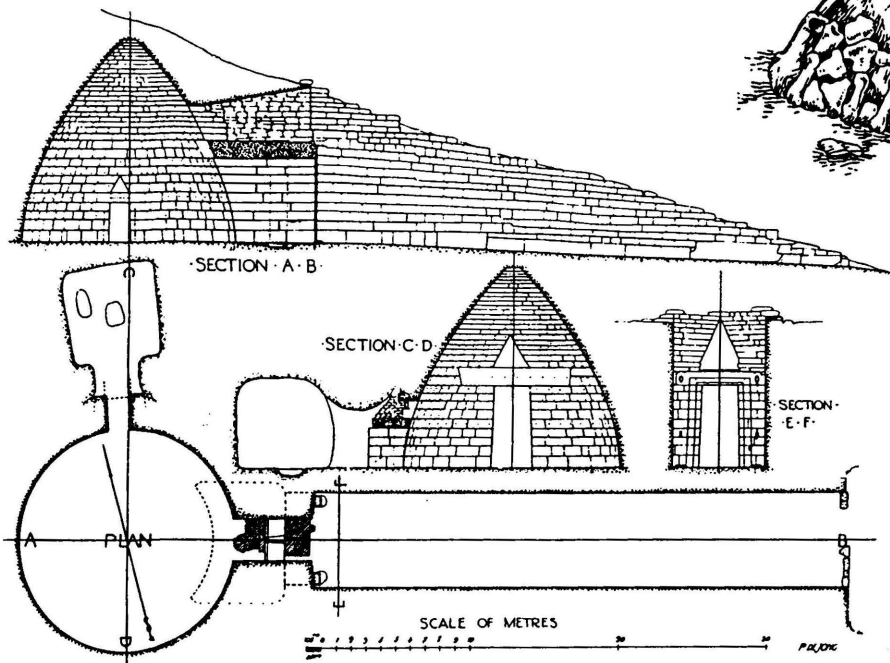
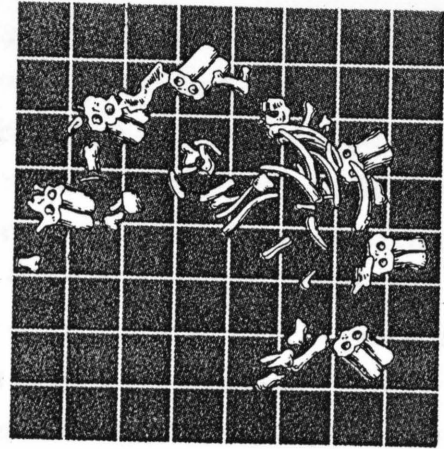
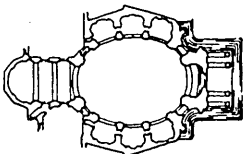

FIGURE 7.8

- FIGURE 7.6 A reconstruction of an Upper Palaeolithic dwelling in the Ukraine.
- FIGURE 7.7 Diagrammatic plan of an Etruscan tumulus (C 7-5 B.C.).
- FIGURE 7.8 The 'Treasury of Atreus', Mycenae (c.1325 B.C.).

he carried with him the pattern of "home". This he gave expression in whatever material came to hand. When locked into the white wastes of an Ice Age he even resorted to mammoth bones, skin and sods driven from the permafrost (figure 7.6). In his longing for a return to Eden he imagined his Soul immortal and buried his dead with rituals which would assure a rediscovered Paradise and an everlasting life. The memory of the home which he had devised in Eden became the home of his eternal Soul. The round house which had found expression in so many materials now became the funerary memorial to the Soul. Giedion (1971:20-68) discusses the significance of this building form in the transition from what he terms the 'first space conception' to the 'second space conception'. Here we shall only examine the plan form.

As the soul has no size so the dimensions had no material value and needed only to be modelled in miniature. Such a home for the soul can be found in the relics of the Etruscan culture, (figure 7.7) baked from the potters clay and designed to hold those physical remnants after decay or cremation.' The intention of the building a house for the dead was not only to guarantee the comfort of familiarity but also the perpetuation of memory and the deification of the deceased. Hence tombs such as the tholos of Agamemnon are of monumental scale in order to glorify the dead and rank them with the Gods (figure 7.8). These tombs became the models of the cosmos, coned and



RÓMA. STA. MARIA DI MONTE SANTO
(XVII. sz. vége — C. Rainaldi,
G. L. Bernini, F. Fontana műve)

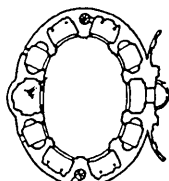

RÓMA. S. ANDREA AL QUIRINALE
(1678 — G. L. Bernini műve)

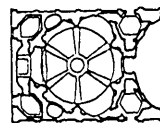

RÓMA. S. IVO ALLA SAPIENZA
(1660 — F. Borromini műve)

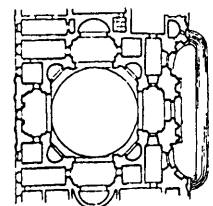

RÓMA. STA. AGNESE
(XVII. sz. közepé — C. Rainaldi,
F. Borromini műve)

Opp. 91

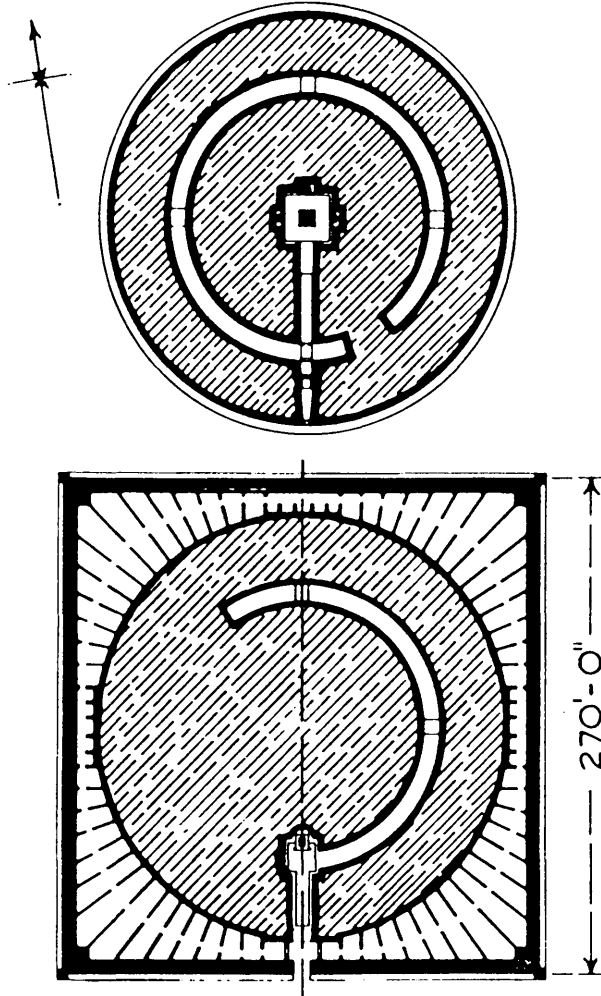

FIGURE 7.9

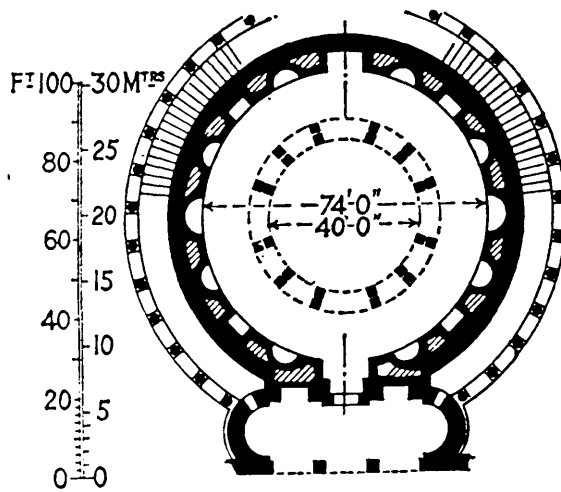

FIGURE 7.10

FIGURE 7.9 The mausoleum of Hadrian, Rome (A.D. 139).

FIGURE 7.10 S. Constanza, Rome (A.D. 330).

centralised. They emphasise the importance of the deceased and by modelling their position in the cosmos hoped thereby to guarantee their place in the cosmic realm.

The Romans who had looked to the Greeks as rôle models for their way of doing, and as heirs to the Etruscans, erected on the cemetery side of the River Tiber their tombs of the dead. Hadrian's tomb, one of the most monumental of these, which survives as the Castel San Angelo, displays the same cosmic modelling of centralised plan and circular plan form (figure 7.9). This tradition of mausoleum (a term derived from the tomb of King Mausolus) as deification of the dead persisted into the Christian era and is exemplified by Santa Constanza, the tomb erected by Constantine for his daughter Constanza in Rome (figure 7.10).

7.7 THE SYMBIOTIC HOUSE

The centralised circular plan has been explored and exploited where the Godhead has needed to be concretised. In that the circular plan deified the dead, it was meant also to make manifest God on earth. Particularly in the domed central plan the building gave expression to the cosmic order - usually as a square ground plan portraying the earth with its cardinal points and relating it to the path of the sun. This order was subjugated to that of the heavens by the superpositioning of the dome. This gives



RÓMA.
 S. CARLO ALLE QUATTRO FONTANE
 (XVII. sz. második fele —
 F. Borromini műve)

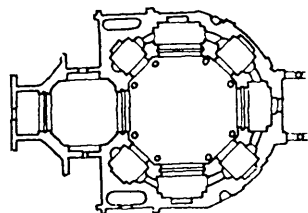

TORINO. LA SUPERBA
 (1717—1731 — F. Juvara műve)

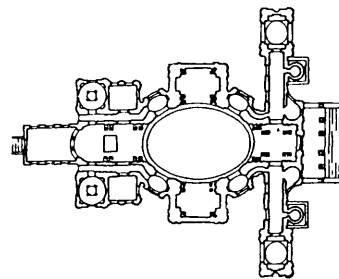

BÉCS. CARL BORROMÄUS TEMPLOM
 (1716—1739 — J. B. Fischer v. Erlach műve)

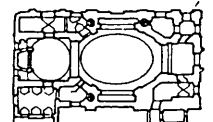

BUDAPEST. SZT. ANNA TEMPLOM
 (1740—1762 — Hámton K., Nepauer M.
 műve)

Opp. 92

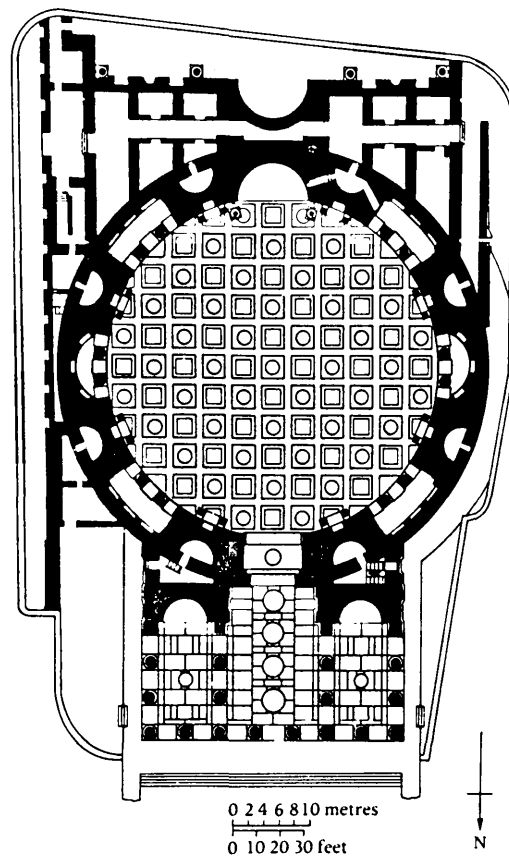

FIGURE 7.11 Pantheon, Rome (A.D. 120 - 4).

expression to cosmic space where sun, moon, planets and stars traverse in eternity. The circular plan embodies this sense of cosmic infinity and eternity. The Pantheon of Rome is the most perfect of all such expressions since not only could it be dedicated to a circularity of seven gods but also to their equal eminence in the cosmic order (figure 7.11). The reinterpretation of the cosmic order within the Christian Church lead to the compromising of the centralised space to the path of salvation.

Where the Christian Church has been geographically more closely allied to the culture of the Middle-East the symbolism of the centralised space has held and is still given expression in both the churches of Greek and Russian orthodoxy. It is a form which continues to be explored as the concretisation of the earthly house of God and a theme boundless in opportunity.

7.8 THE MECHANISTIC HOUSE

'One may look at the strange idea of a spherical building from various viewpoints. One may recognize in it the unbridled will of innovation, the will to create something extraordinary, or one may blame its lack of "soundness". One may find the motivating force behind the curious invention in a predilection for elementary shapes or one may point out that the sphere represents the "withdrawing" form in the most perfect manner and thus is most suitable to express the idea of self-contained individualism. To Houel, the

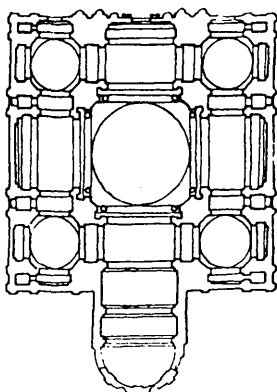

BRESCIA. DÓM
(XVII. sz. eleje)

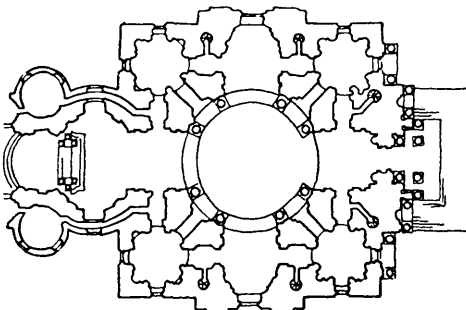

PÁRIZS. INVALIDUSOK DÓMSJA
(XVIII. sz. eleje — J. H. Mansart műve)

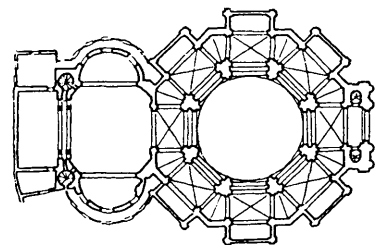

VELENCE. STA. MARIA DELLA SALUTE
(1631—1687 — B. Longhena műve)

sphere was the perfect symbol of equality; Ledoux praised it as an excellent means to express sublimity. Since time immemorial the sphere has been to mankind the symbol of eternity. It appealed quite particularly to the architects of the Revolution who were artists enough to forget about practicality, when they aimed at grandeur or at form' (Kaufmann, 1968:185).

In the Age of Reason man usurped that which was traditionally held to be the preserve of God as his own. Not only did he take unto himself the creative faculty of God (as is evidenced by the discussion of the word in Chapter 9) but also the symbolic expression of his presence on earth. Here the circular dwelling was expropriated as being expressive of man's own divinity and the symbolism reformed to give expression thereto. Man, the focus of a homocentric cosmos, the equal of all other men, infinite in faculty, united in brotherhood and equipoised in reason took unto himself the centralised plan as symbol of all this. The pursuit of Primitive or Natural Man also re-inforced the rightness of such a plan-form as being the natural home to reasonable man. It is therefore not surprising that the theme was explored almost fetishistically by the Revolutionary architects. Even less surprising is that so little of what was visualised was built since not only was the form impractical but also atectonic.

The Enlightenment of the C18 paradoxically stood the primeval fear of darkness on its head and lent to it

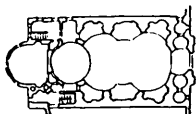

MÜNCHEN. ANNA TEMPLUM
(XVIII. sz. első fele — J. M. Fischer műve)

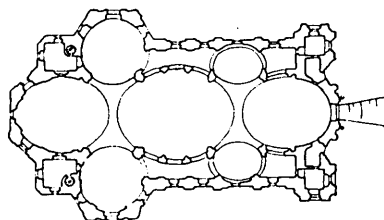

VIERZEHNHEILIGEN.
BÜCSÚJÁRÓ TEMPLUM
(1743 — B. Neumann műve)

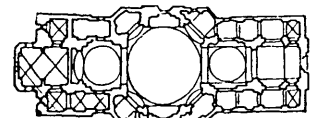

ROTT AM INN. BENCÉS-TEMPLOM
(XVIII. sz. második fele)



Opp. 94



FIGURE 7.12 Plate 8 of Carceri d'invenzione , Piranesi (c. 1761).

a desirability. Piranesi, inspired by the ruins and tombs of ancient Rome, explored the darkness of the psyche in his series of 'Carceri'. It was particularly in the second state of the etchings that these gloomy interiors of bridges and stairs-to-nowhere defied the logic of perspectival space and took the beholder into a labyrinthine nether-world of the sub-conscious (figure 7.12). Edmund Burke (in Bouldon, 1967) grasped the opportunities offered by the discovery of the sub-conscious and in a parallel to Linnaean taxonomy of the biological realm attempted his ordering of the range of sensations. He juxtaposed the experience of the sublime with that of beauty. The sublime he related to, amongst others, the sensations of 'tranquil terror' excited by darkness and blackness.

Tranquil terror, as member of that particularly European affliction of sado-masochism, can probably be psychologically related to the exquisite pain and bearable suffering explored in Baroque religio-erotic representations of martyrdoms - drawn tongues, gouged eyes, flayed skins and unwound entrails. Only, in its degree of abstraction away from the directly physical to the psychological, from animate to the inanimate and from the spiritual to the temporal, sublimity is a discovery by the emergent rational mind as expounded by the C18 French man of letters and propagator of the art of anarchic sexual violence, the Marquis de Sade.

The tranquil terror excited by experience of darkened

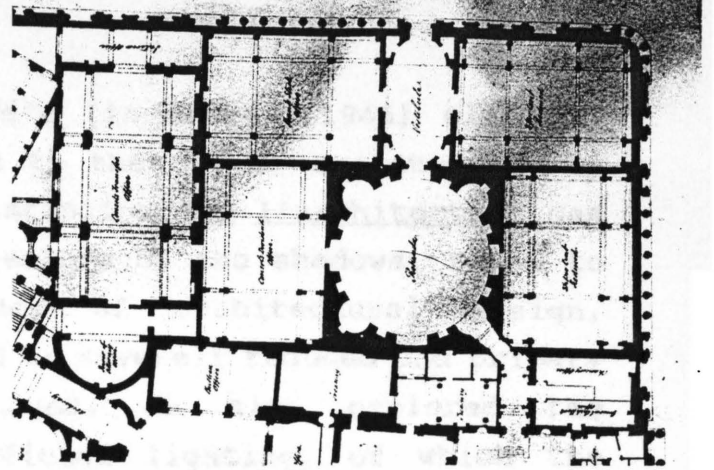
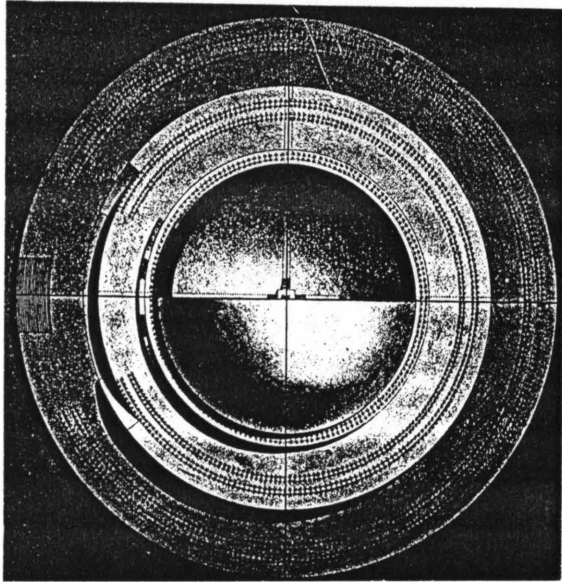

FIGURE 7.14

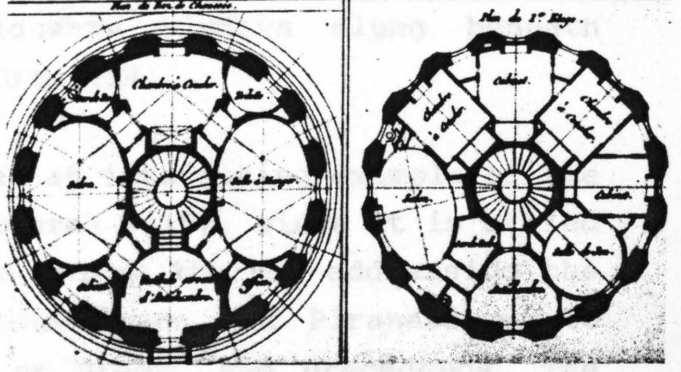
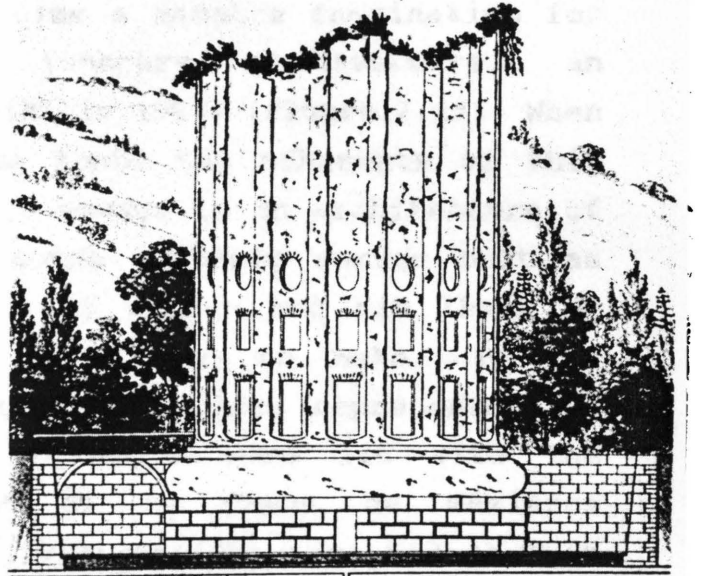
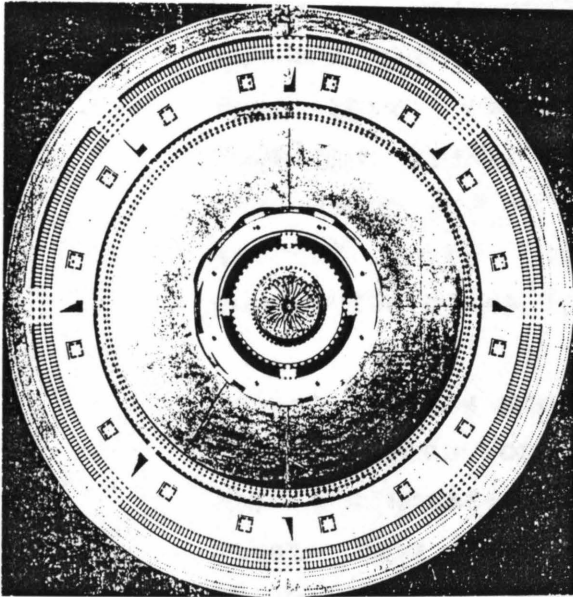

FIGURE 7.13

FIGURE 7.15

FIGURE 7.13 The architecture of death - Newton Cenotaph, Boullée (c. 1780) and the Funerary Chapel, Fontaine (1785).

FIGURE 7.14 Bank of England - detail plan of banking halls, John Soane (1788 - 1833).

FIGURE 7.15 Desert de Retz, floor plans of house for Racine de Monville, Francois Barbier (1774 - 84).

spaces led to Boullée's (in Rosenau,1946) claim of making a contribution to the art of architecture by introducing to the discipline "de l'architecture des ombrés" or the architecture of the shadows. So as to emphasize this aspect of architectural design, decoration was omitted or severely reduced and primary tectonic forms employed. He also explored the architecture of artificial lighting, of which the Newton Cenotaph remains the famed example. There existed also at that time a macabre fascination for the designing of funerary architecture, an architecture of death (Etlin,1984) (figure 7.13). When not actually designing tombs the adherents of this school of thought would engage in an architecture of subterranean spaces. Soane probably serves best as exponent of this genre of design and his 'Bank of England' (shamefully demolished to make way for Baker's successor) as the exemplary representative. The linked sequence of halls were lit with the 'lumiere mysterieuse' of Le Camus de Mézières (Middleton and Watkin,1980:206&408) admitted through pierced oculi or lunette windows slung beneath pendentive domes (figure 7.14).

Desert de Retz provides an interesting example of the circular plan form (figures 7.15), since it is styled into a truncated Ionic column thereby addressing the debate spirited by Winckelmann and Piranesi as to which culture, Roman or Greek, had precedence. The sublime of the ancient, the enormous, the decayed the

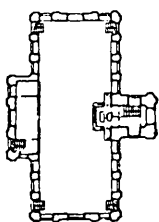

L. STURM PROTESTÁNS TEMPLOM
 TERVE
 (XVII. sz. végc — XVIII. sz. eleje)

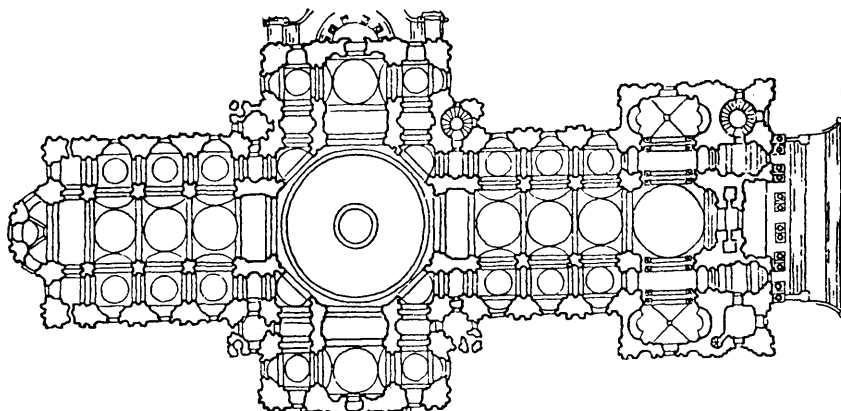

LONDON, SZT. PÁL SZÉKESEGYHÁZ
 (1675—1710 — Ch. Wren műve)

June 29, 1954

R. B. FULLER
BUILDING CONSTRUCTION

2,682,235

Filed Dec. 12, 1951

8 Sheets-Sheet 1

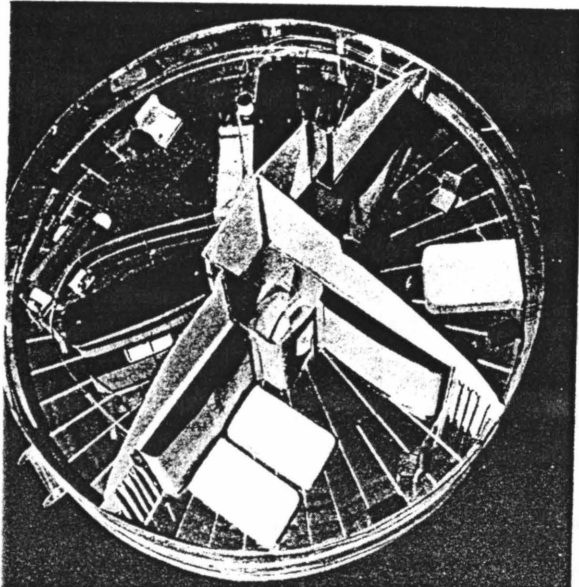
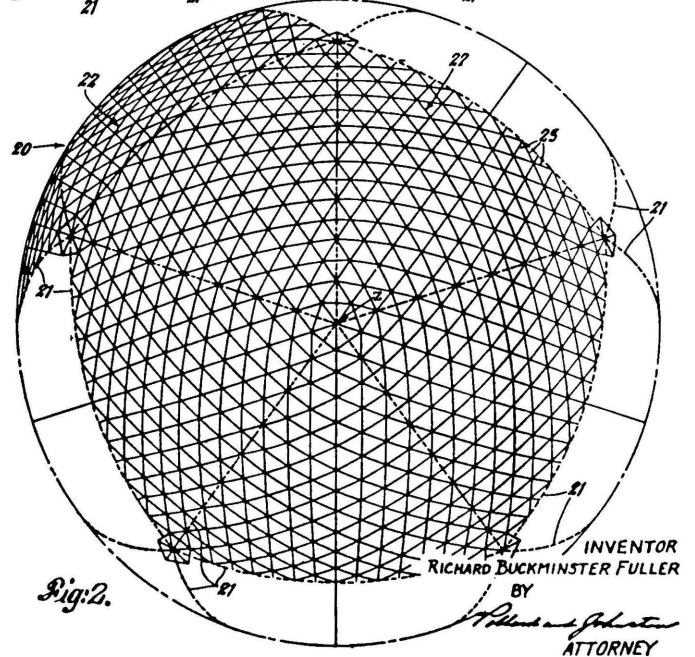
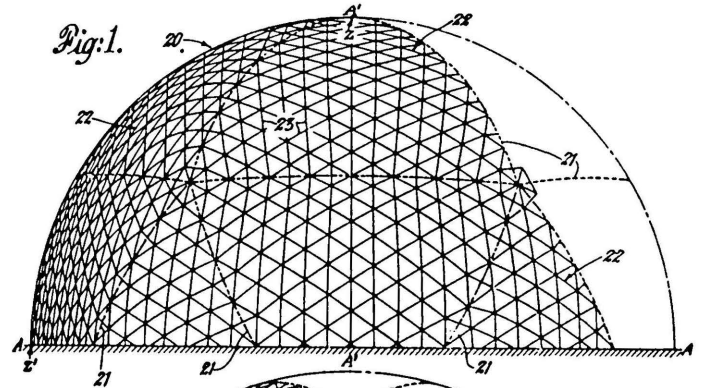

FIGURE 7.16

FIGURE 7.17

FIGURE 7.16 Dymaxion House, Buckminster Fuller (1927-).

FIGURE 7.17 Geodesic Dome, Buckminster Fuller (1954-).

succumbing of the works of man to Nature and the transience of man are all here deployed. This then the darker side of the idealisation of Man and his works.

7.9 THE ECOSYSTEMIC HOUSE

Enlightened Man, who sacrificed the hope of his soul to the here-and-now of physical being, became ever more obsessed with the possibilities posed by his material reality. The Industrial Revolution had brought with it a host of materials which could be explored and creatively exploited in the built environment. What should be the guiding principle in the use of these materials? The pioneers of the Modern Movement having abandoned the determinance of style had no tradition in the use of the materials available. The principles whereby the materials should be utilised were those dictated by function and honesty. Buckminster Fuller was supreme exponent of the use of the minimum material to achieve maximum efficiency. He coined 'synergy' to name his ruling principle which is: 'The behaviour of a whole system unpredicted by the behaviour of any one or any sub-set of its parts' (Meller, 1972:385). His Dymaxion house (figure 7.16) is prime example of the reinterpretation of the home delivered from tradition and invented afresh. So too the geodesic dome (figure 7.17), which evokes memories of Man's first home but with the rationale of maximum enclosed space by a minimum of material. Drop City of the Hippy drop-out generation

Opp. 97
WHAT WE LOVE ABOUT OUR DOME...
IT'S BIG

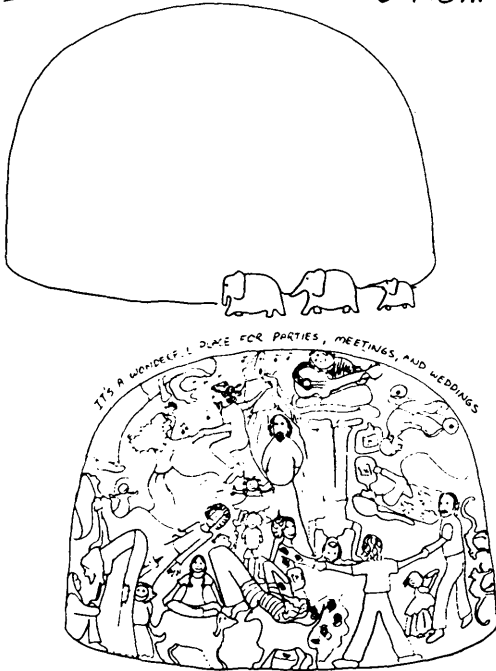

KIDS LOVE IT!

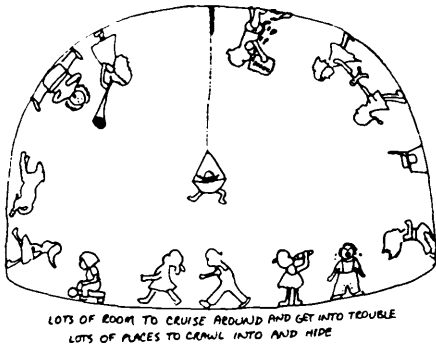

LOTS OF ROOM TO CRUISE AROUND AND GET INTO TROUBLE
LOTS OF PLACES TO CRAWL INTO AND HIDE

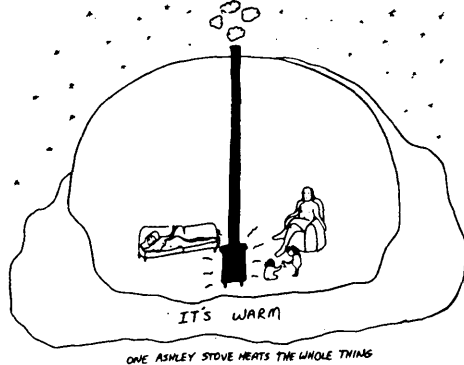

ONE ASHLEY STOVE HEATS THE WHOLE THING

WHAT WE HATE ABOUT OUR DOME

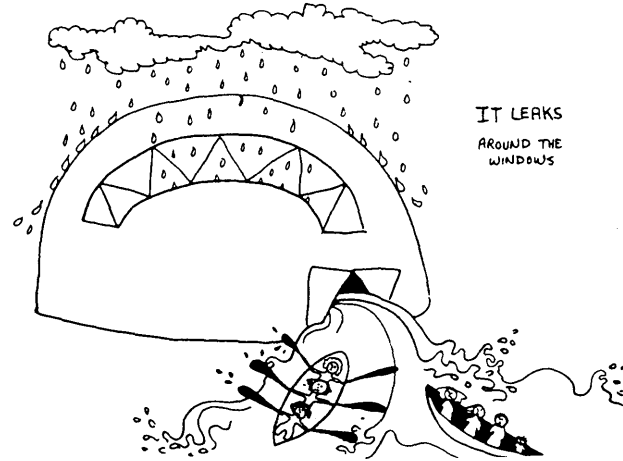

IT LEAKS
AROUND THE
WINDOWS



IT'S TOO HOT IN THE SUMMER AND
IT ATTRACTS FLIES!
(SOME KIND OF GIANT WINDOWSHADE SHOULD SOLVE THESE)

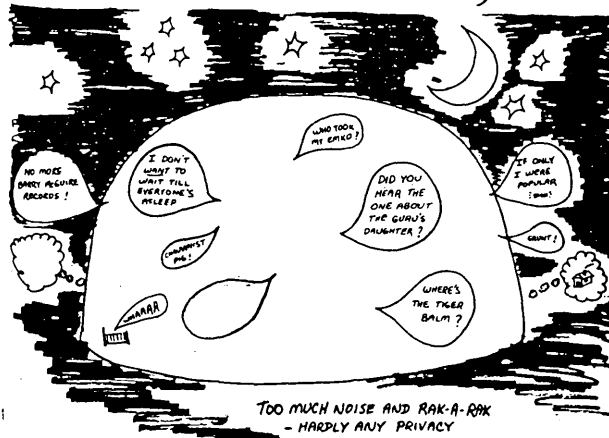

TOO MUCH NOISE AND RAK-A-RAK
- HARDLY ANY PRIVACY

FIGURE 7.18 'What we love and hate about our dome'. 60ft Red Rocker's dome (1970).

welded this minimalism with a cult of back-to-nature and the make-love-not-war ethic. The use of a minimum material, recycled waste and natural energy satisfied their tender-minded sense of being kind to Mother Earth (Kahn,1973) (figure 7.18).

Yet however noble the sensitivity to the limits of the resources of the earth, in only addressing physical aspects the full ecosystemic realm remains unsatisfied.

'Dr. M.-L. von Franz has explained the circle (or sphere) as a symbol of the Self. It expresses the totality of the psyche in all its aspects, including the relationship between man and the whole of nature. Whether the symbol of the circle appears in primitive sun worship or modern religion, in myths or dreams, in the mandalas drawn by Tibetan monks, in the ground plans of cities, or in the spherical concepts of early astronomers, it always points to the single most vital aspect of life - its ultimate wholeness' (Jaffé in Jung,1978:266).

'Every building, sacred or secular, that has a mandala ground plan is the projection of an archetypal image from within the human unconscious onto the outer world. The city, the fortress, and the temple, [the house] become symbols of psychic wholeness, and in this way exercise a specific influence on the human being who enters or lives in the place' (Jaffe in Jung,1978:273).

It was Jung who in the description of his own home, welded to the physical manifestation the archetypal image:

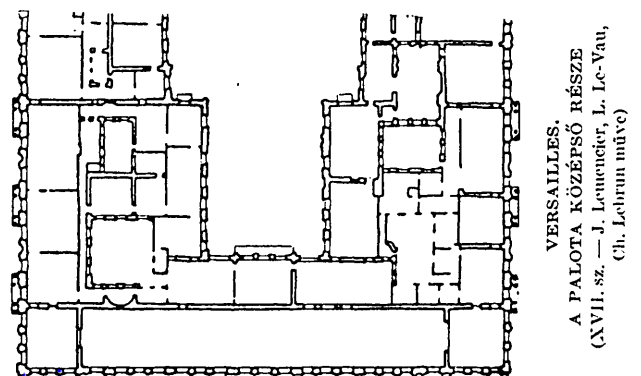
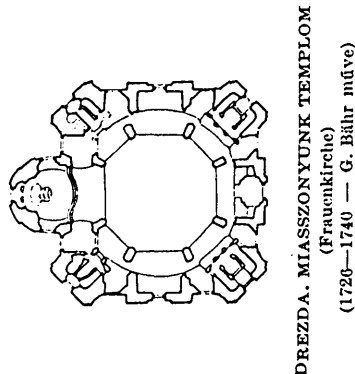
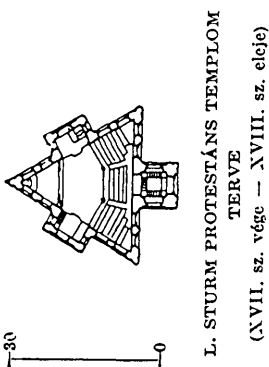

Opp. 98



FIGURE 7.19 The Tower - Jung's home in Bollingen, Switzerland (1920).

'At first I did not plan a proper house, but merely a kind of primitive one-storey dwelling. It was to be a round structure with a hearth in the centre and bunks along the walls. I more or less had in mind an African hut where the fire, ringed by a few stones, burns in the middle, and the whole life of the family revolves round this centre. Primitive huts concretise an idea of wholeness, a familial wholeness in which all sorts of small domestic animals likewise participate. But I altered the plan even during the first stages of building, for I felt it was too primitive. I realised it would have to be a regular two-storey house, not a mere hut crouched on the ground. So in 1923 the first round house was built, and when it was finished I saw that it had become a suitable dwelling tower.

The feeling of repose and renewal that I had in this tower was intense from the start. It represented for me the maternal hearth' (Jung, 1963:250-1) (figure 7.19).

That which was locked into the communal memory is now revealed and in knowing that he is heir to such memory Man has lost his innocence. No longer is that which we make just the product of the enterprise of manufacture but also a revelation of what we innately are. But though without innocence we can still make meaningful our enterprises. So it is with architecture. We do not only have to continue to satisfy Man's physical needs but must also nurture his psychological and spiritual well-being.

In our exploration of the round house we have come full circle. We must once more examine the home of natural Man and discover those archetypal elements

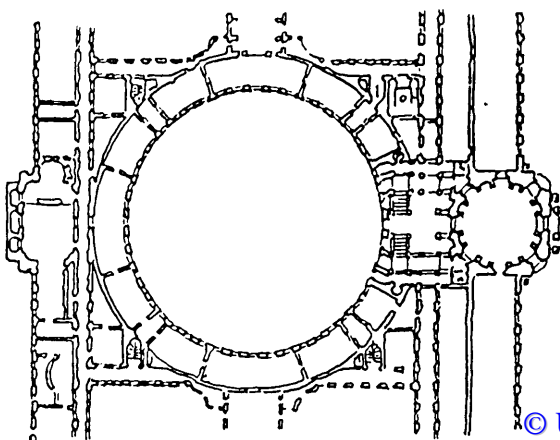

LENINGRÁD.
 SZÉPMŰVÉSZETI AKADEÉMIA
 (1765-772 — J. B. Dellanotte,
 A. F. Kokorinov műve)

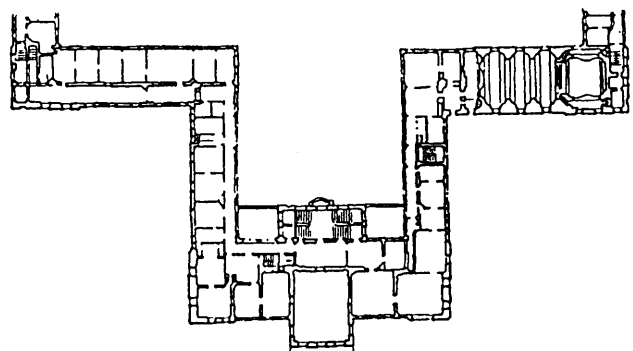

GÖDÖLLŐ. KASTÉLY
 (1744-1750 — feltetékén Mayerhofer A. műve)

Opp. 99

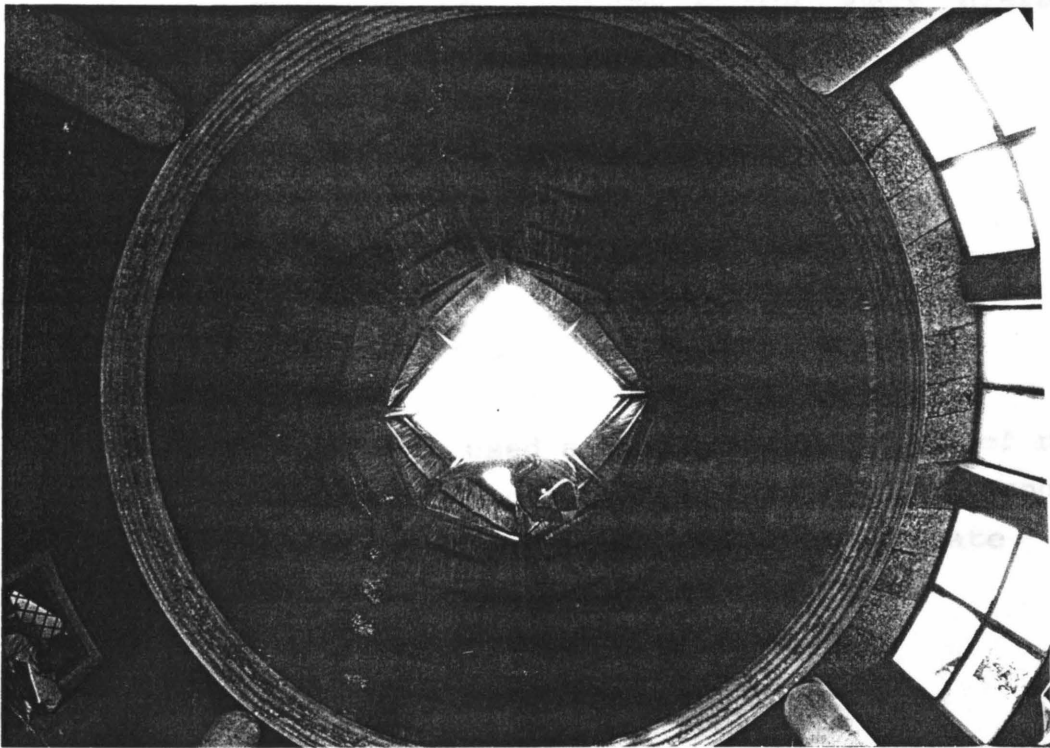

FIGURE 7.20 The Electronic Hut - Twin Thatches living room, Kloofzicht, Pretoria (1887 and 1987).

which satisfy the psyche - the hearth at the centre, the dome of the heavens, the pillars of the earth, the oculus, the "wind-eye" - all are things to which Man responds intuitively and which comfort him in his earthly sojourn (figure 7.20).

7.10 SUMMARY

In wishing to interpret the house, and specifically the round house, iconologically Rapoport's socio-cultural approach has been accepted. To the categories, here termed paradigmatic episodes, of Cosmological, Symbiotic and Exploitative (here termed Mechanistic) have been added Sympathetic and Ecosystemic to form an evolutionary hierarchy of paradigms:

- Sympathetic
- Cosmic
- Symbiotic
- Mechanistic
- Ecosystemic

Each has been used as a contextual frame of reference for understanding the exploitation of the round plan-form for the house and appropriate meanings ascertained.

7.11 CONCLUSION

The sixth subproblem was to ally plan styling to

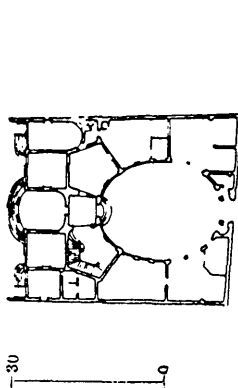

PÁRIZS, HOTEL AMELOT
(XVIII. sz. első féle — G. Boffrand műve)

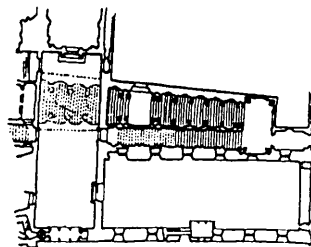

RÓMA, Vatikáni Palota részlete
»Scala Regia«
(XVII. sz. vége — G. L. Bernini műve)

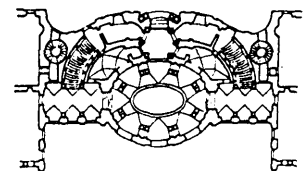

TORINO, PAL. CARIGNANO
(1680 — G. Guarini műve)

episodes of paradigm shift or change.

The sixth hypothesis was that since the plan is an interactive artefact of its time it can only be iconologically interpreted contextually.

When placed within the context of the prevailing paradigm wherein it is employed the round plan form as 'house' can be iconologically interpreted and its meaning discerned. Although the plan-form remains constant, the meaning ascribed is dependent on the context of not only the time and place but also the paradigm of its making. The artefactual material, namely the plan, need not be of its time to be understood, but the paradigm of the time should be identified for meaningful interpretation. The enquiry is supportive of the hypothesis.

30
0

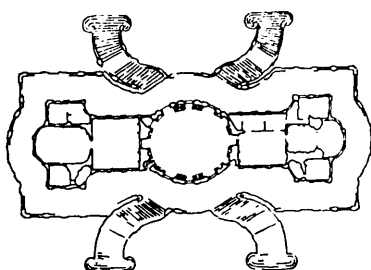

STUTTGART.
SOLITUDE KASTÉLY
(XVIII. sz. közepe
— P. de la Guépière műve)

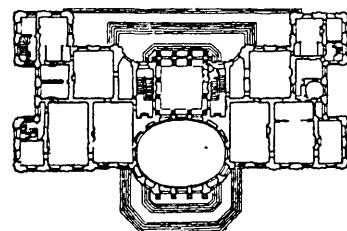

VAUX LE VICOMTE.
KASTÉLY
(1643—1661
— L. Le Vau műve)

CHAPTER 8

RECAPITULATION, CONCLUSION AND ACHIEVEMENTS

8.1 RECAPITULATION

In this study the following aspects of the plan have been investigated:

- as artefact
- as style bearer
- the iconographic reading thereof
- the iconological reading thereof
- its traditive role function
- its interactive role in the cultural realm

In Chapter 2 it was found that :

"the ecosystemic view permits us a placing of the artefact within a hierarchy of the biological realm, from the by-product of biotic activity through to a bearing of the imaginary artefact in mind. The systemic activity of the level at which the artefact is examined will determine its ascribed significance. The greatest significance which the artefact can achieve is as cultural agent within the socio-cultural domain. Here the significance is abstracted into a hierarchy of image, sign symbol and icon".

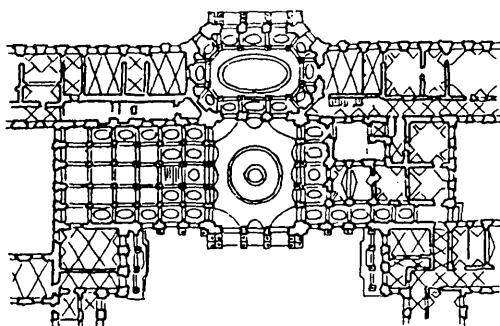

WÜRZBURG.
 ÉRSEKI PALOTA KÖZÉPRÉSZE
 (1719—1744 — J. B. Neumann műve)

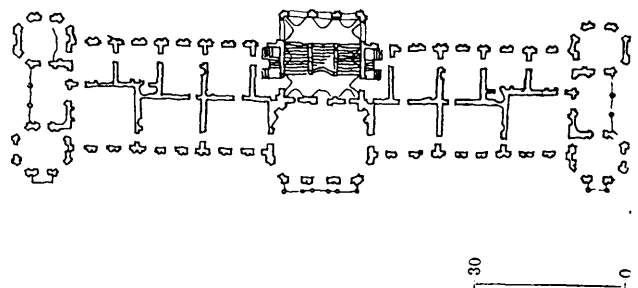

BÉCS. BELVEDERE
 (1893—1724 — L. v. Hildebrand műve)

In Chapter 3 an ecosystemic understanding of the term style was explored.

"Certain cultural activities of a community are at a pre-iconic level and are not exploited for stylistic experimentation. Such aspects will persist and become canonical and not be consciously recognisable as 'style' to the members of a community. Such pre-iconic, or isochrestic, style is tacitly agreed to and further style variation thus determined.

The opportunities for enrichment of styling is a function of time. The degree to which each level of styling is exploited and the degree to which the manner of doing becomes canonical in time is indicative of evolving cultural stability and diversity. The degree of abstraction in styling is indicative of cultural depth and maturity. This should all be able to be 'read' in the styling of the artefact.

Since styles always emerge from traditive elements and the future determined by the destiny selection of the past the logic of style development has to be established ex post facto.

If the cultural system of which the style is part changes then the style will change. If change encourages the historians to coin a new style

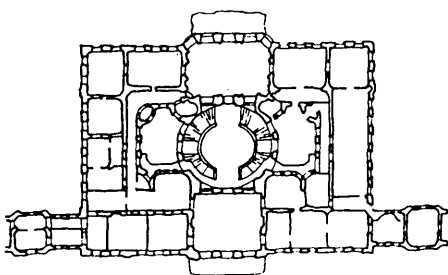

BRUCHSAL.
A PALOTA KÖZÉPSŐ RÉSZÉ
(XVIII. sz. első fele —
I. Stahl, B. Neumann műve)

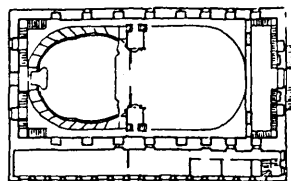

DREZDA. SZÍNHÁZ
(XVIII. sz. első fele — Bibiena műve)

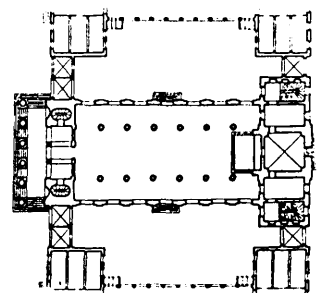

KARLSRUHE.
EVANGÉLIKUS TEMPLOM
(1807—1815 — F. Weinbrunner műve)

term then it is indicative of a changed system of culture with another set of tacit guides. Through style interpretation these can be made overt by the historian. The use of a synoptic terminology for style designation helps to capture the essence of the manner and spirit of such doing.

Past cultures can be accessed hierarchically through analysis of artefact from pre-iconographic, through iconographic up to iconological interpretation. As such, artefacts retain potency. Ideas can be reformulated and again given currency. The artefact thus has ecosystemic agency".

In Chapter 4 a particular view was taken of the plan-artefact.

"The plan is more than the planning. By definition it is an abstracted graphic section to scale of the arrangement of building elements depicted through conventions on the horizontal plane. Yet not all plans have the same image. Through the musical analogy the original might show the style of the author, but through transcription conveys also his intent. This persists while copies are extant, the building being merely an interpretation thereof. The manner of making of the plan allows for iconographic interpretation whereby its type can

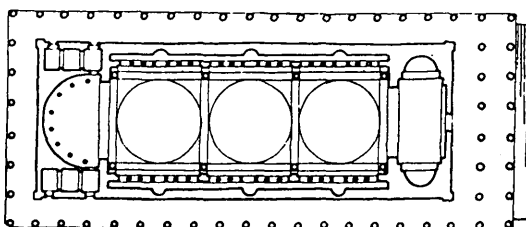

PÁRIZS. MADELEINE
(XIX. sz. eleje — B. Vignon műve)

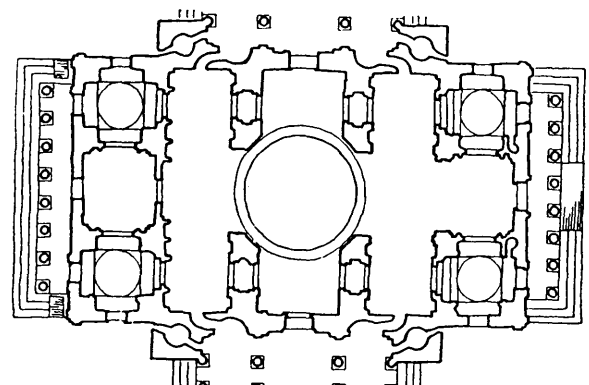

LENINGRÁD.
IZSÁK SZÉKESEGYHÁZ
(XIX. sz. közepe — R. De Mont-Ferrand műve)

be ascertained and its historical time and place determined.

In Chapter 5 select aspects of plan-style which can be iconologically interpreted were identified.

"The plan has been shown to have as image various meaningful aspects namely:

- phenomenological meaning
- perceptual recall
- homospacial display
- articulation
- type
- narrative
- space-force fields
- place and path
- archetypal association

The plan can also be interpreted at higher levels in the visual hierarchy:

- as sign its function can be represented by its form, for instance Ledoux 'Oikema'.
- as symbol its associations can be recalled through employment of typical imagery, for instance the theatre as building type.

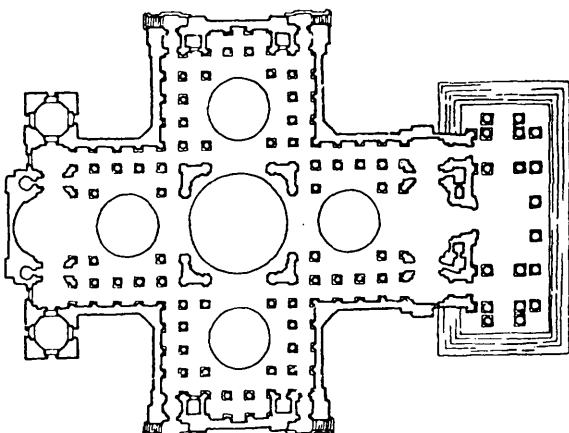

PÁRIZS, PANTHEON
(1764—1781 — J. G. Soufflot műve)

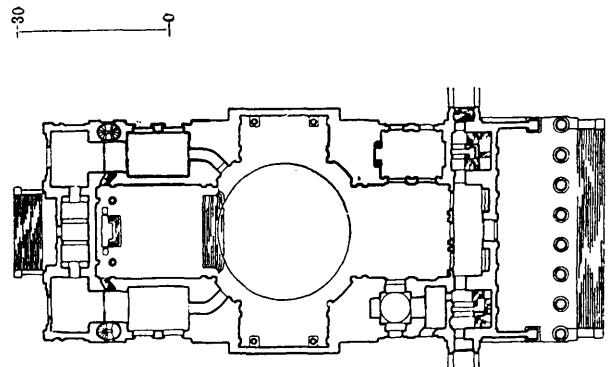

ESZTERGOM, SZÉKESEGYPHÁZ
(1822 — Kúthnel J., Paekh J., Hild J. műve)

- as icon it can symbolise the analogous activity of man's associated enterprise, for instance the Christian church as icon of the Christian life.

These abstract elements of plan style can be read just as readily from reconstructed or reproduced plans as from the original plan artefacts".

In Chapter 6 the plan as traditive agent was tested through the pursuance of the country house as plan-type.

"A pedigree of the free plan, centred around a core and extending into the landscape has been set out.

In our exploration we have seen that the plan as emblem may be propagated through time in terms of its 'memetic' content, but that the individual will bring to the pattern schema of his own. These derive just as readily from the rational as from the intuitive mind. The potency for perpetuation through time of the individual contribution is dependent on the clarity and dissemination of the plan image. This can thereafter be investigated, reinterpreted and elaborated. It becomes part of the currency of exchange of the discipline. Whereas the rational component of the plan can be perpetuated and

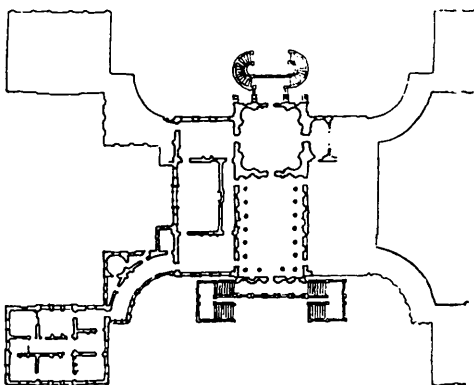

DERBYSHIRE, KEDLESTONE HALL
 (XVIII. sz. vége —
 Robert és James Adam műve)

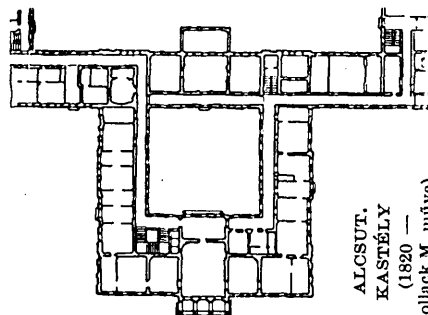

ALCsut.
 KASTÉLY
 (1820 —
 Pollack M. műve)

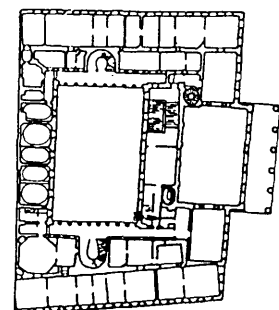

BUDAPEST, LLOYD-PALOTA
 (1827—1830 — Hild J. műve)

modified, the intuitive component has every time to be rediscovered and re-explored".

In Chapter 7 the round house was investigated as type and contextual meaning derived from the prevailing paradigm of its making.

"In wishing to interpret the house, and specifically the round house, iconologically Rapoport's socio-cultural approach has been accepted. To the categories, here termed paradigmatic episodes, of Cosmological, Symbiotic and Exploitative (here termed Mechanistic) have been added Sympathetic and Ecosystemic to form an evolutionary hierarchy of paradigms:

- Sympathetic
- Cosmic
- Symbiotic
- Mechanistic
- Ecosystemic

Each has been used as a contextual frame of reference for understanding the exploitation of the round plan-form for the house and appropriate meanings ascertained".

8.2 CONCLUSION

The main problem was "to determine an ecosystemic role for the changing style of 'the plan', it being that

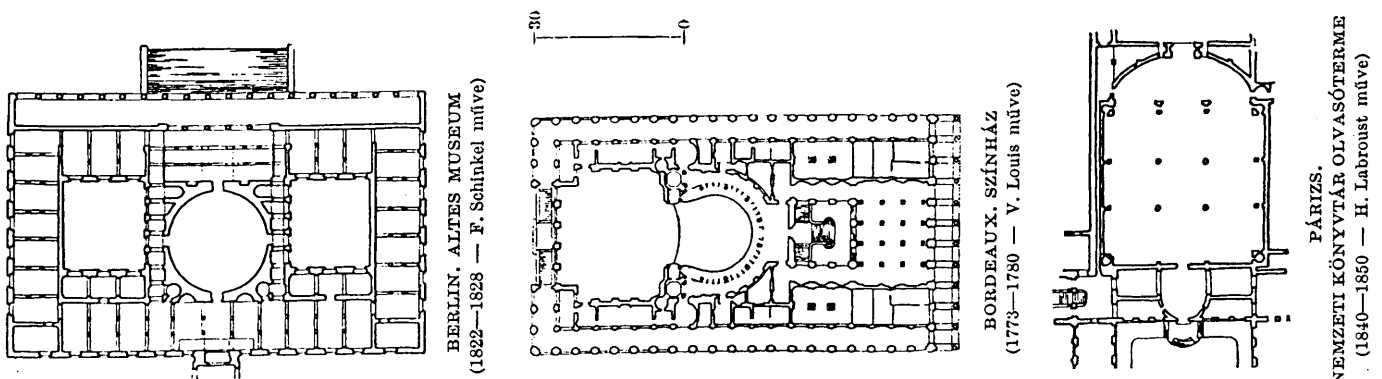

artefact characteristic to the discipline of architecture".

The main hypothesis was "that 'the plan' through style, has an ecosystemic role in the cultural realm".

The first subproblem was "to determine the role of the architectural artefact in the cultural realm".

The first hypothesis was "that the artefact has ecosystemic agency".

"The artefact within the socio-cultural realm is actively encountered by mindful individuals with the associated techniques of memory and recall. The role of the artefact within the cultural realm is that of meme bearer and as such it has ecosystemic agency. The hypothesis is thus supported by the arguments presented".

The second subproblem was "to determine a sense of style within the Ecosystemic Paradigm".

The second hypothesis was "that, through styling, artefacts are encoded with cultural significance".

"Styling has not only been shown as a means of cultural encoding but the employment of style has been shown to be hierarchical and dependent on the cultural maturity of the community with which

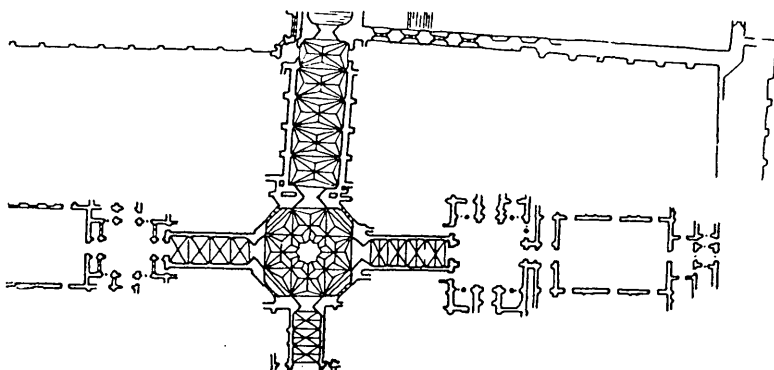

LONDON, PARLIAMENT
(1840—1852 — Ch. Barry müve)

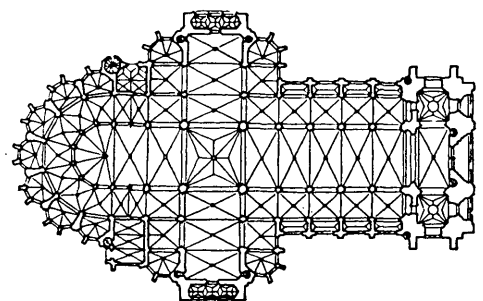

BÉCS, FOGADALMI TEMPLOM
(1856—79 — H. v. Ferstel müve)

it is associated. Ecosystemically styling has cultural significance both synchronically or interactively as a means of cultural recursiveness and diachronically or traditively as a means of cultural autopoiesis. The hypothesis is supported but seems to be restricted and will therefore be expanded into the assertion that 'artefacts have stratified encoding of cultural significance through styling'".

The third subproblem was "to determine the relationship of 'style' to 'plan'".

The third hypothesis was "that the plan has style".

"Iconographic interpretation allows for the association of the artefact with its type, place and time. The historical overview of the plan as artefactual type has given some insight into the manner of doing in its time and place of making. By definition the style of the plan allows for iconographic interpretation. Hence the plan must be said to have style. The hypothesis is thus supported by the investigation".

The fourth subproblem was "to identify which aspects of the plan as image can be iconologically interpreted".

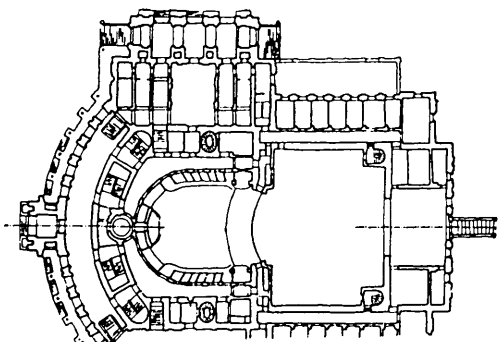

DREZDA. SZÍNHÁZ
(1871—1878 — G. és M. Semper műve)

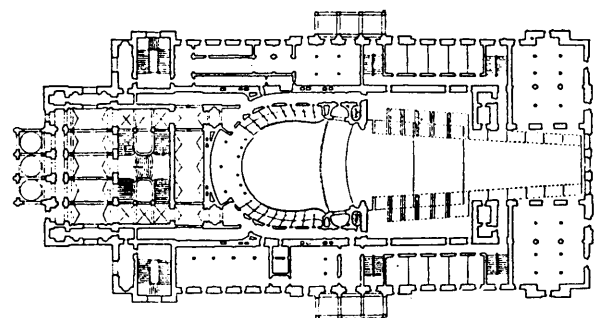

BUDAPEST. OPERAHÁZ
(1870—1884 — Ybl M. műve)

The fourth hypothesis was "that the plan-image matches the hierarchy of visual recall, namely: image, sign, symbol and icon".

"In being able to present a meaningful discussion the hypothesis is supported.

The plan, both as original and reconstructed or reproduced artefact, is a valuable source for iconological interpretation".

The fifth subproblem was "the demonstration of the continuity of architectural type through the genealogy of plan images".

The fifth hypothesis was "that the plan can evolve in a traditive manner".

"It has been discovered that the Palladian English country house, as emblem of the propertied and enfranchised individual, has been popularised through the medium of publication and has undergone stylistic metamorphosis in its redeployment. The plan image can thus be said to have played a traditive role in the development of the country residence. The hypothesis, through illustration, is supported".

The sixth subproblem was "to ally plan styling to episodes of paradigm shift or change".

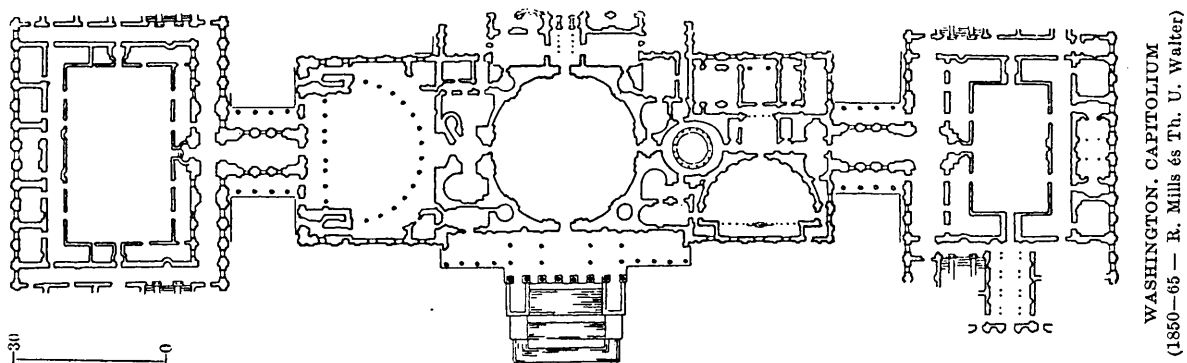

The sixth hypothesis was "that since the plan is an interactive artefact of its time it can only be iconologically interpreted contextually".

"When placed within the context of the prevailing paradigm wherein it is employed the round plan form as 'house' can be iconologically interpreted and its meaning discerned. Although the plan-form remains constant, the meaning ascribed is dependent on the context of not only the time and place but also the paradigm of its making. The artefactual material, namely the plan, need not be of its time to be understood, but the paradigm of the time should be identified for meaningful interpretation. The enquiry is supportive of the hypothesis".

The ecosystem was argued as being an hierarchical nesting of interactive systems. The artefact was understood to be an active agent as 'meme' bearer in the socio-cultural realm. 'Style' was argued to be the means whereby the artefact is encoded with cultural significance, and that this significance is hierarchical, from isochrestic through to iconic styling. The plan-artefact through the style of its making allies it to place and time and hence can be iconographically interpreted. Yet the plan has also abstract elements which allow for iconological interpretation. Both the iconographic and iconological interpretations have been demonstrated through the

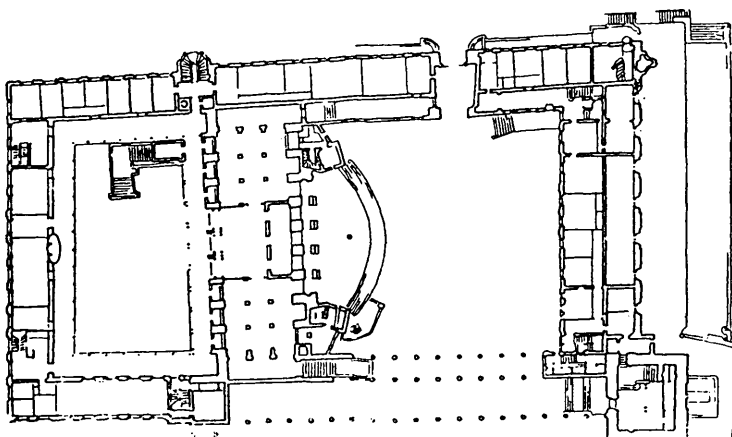

STOCKHOLM. VÁROSHÁZA
(1912—1923 — R. Östberg műve)

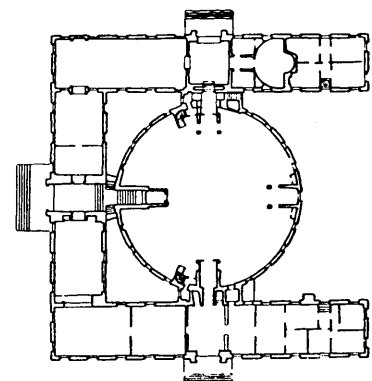

STOCKHOLM. VÁROSI KÖNYVTÁR
(1923—1928 — E. G. Asplund műve)

choice of the house as type for exploration as a testing case.

If the socio-cultural realm is accepted as uppermost in the ecosystemic hierarchy and if it is accepted that the plan has style and through its styling is encoded with 'memetic' content which through iconographic and iconological interpretation gives it both traditive and interactive systemic agency in the cultural realm then the plan must be seen to play, through its styling, an ecosystemic role in the cultural realm. The main hypothesis is thus supported and the main problem resolved.

8.3 DELIMITATIONS AND COUNTER-ARGUMENTS

In Chapter 1 the delimitation was that "only Western culture [would] be examined and used to formulate and substantiate the relevant arguments".

It might be otherwise hypothesised that the plan has the utilitarian function of conveying pertinent architectural information only as regards built form but this would be recognising the pragmatic function of the plan exclusively. As has been argued artefacts are styled, not merely isochrestically but also iconically, and the plan as artefact should be able to be stylistically exploited at the iconic level.

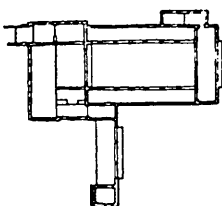

PÉCS. PÁLÓS TEMPLOM
(1933. — Wetelinger K. műve)



STOCKHOLM.
»SÖDRA BEGRÄVNINGSPÅLATS» KÅPOLNA
(1916. — E. G. Asplund műve.)

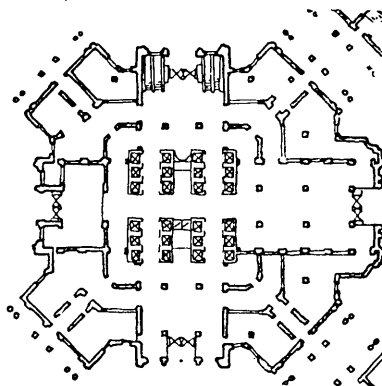

MOSZKVA. MAGASHÁZ. KÖZÉPRÉSZ
(1951. — D. N. Csicsilin, J. M. Gigratov)

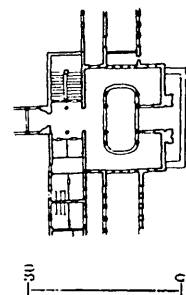

BUDAPEST. ÚJ MŰSZAKI EGYETEM
BEJÁRATI RÉSZE
(1954 — Rimandóczy Gy. műve)

8.4 ACHIEVEMENTS

In the study 'A paradigmatic approach to architectural history: post-modernism' (Fisher, 1989a), the paradigmatic approach was summarised as follows:

"A paradigmatic approach to architectural history requires:

1. the identification of episodes of crisis in the prevailing norms and theories;
2. the identification of the unique artefact within the contemporaneous disciplines;
3. the encountering and interpretation of these artefacts;
4. that these interpretations are synergized to an understanding of the whole period;
5. the retention of the wholeness or context of a period studied" (Fisher, 1989a:23).

In that study style in art was not seen to parallel the paradigms of science as suggested by Laszlo (Chapter 2) but seen to reflect those paradigms. Style change was seen to be as indicative of paradigm shift or change. In choosing the plan as specific artefact characteristic of the discipline of architecture it has now been possible to demonstrate this argument.

The Ecosystemic School of thought which characterises the Transvaal School of Architecture at the University of Pretoria is thus further articulated and in overtly formulating the meta-level of understanding it can be systematically applied, broadened and gainsaid.

In persuing the many readings of the plan-artefact it has been demonstrated how rich the interpretation can be and how valuable the plan is as an aid to architectural understanding.

The role of the plan-artefact as agent for communication has been argued and the importance of significant plans in the synoptic understanding of historical episodes highlighted. The identification of such plans for presentation in the curriculum becomes a paramount consideration.

This study serves as model for investigating other significant architectural artefacts and as basis for parallel investigations.

Finally the methodology followed in the structure of this study can serve as model for similar studies.

CHAPTER 9

SPECULATIONS AND OPPORTUNITIES

9.1 OUTLINE OF CHAPTER 9

Education as the autopoietic agent for cultural stability will be described. The creative nature of education in the design disciplines will be contrasted. The idea of developmental recapitulation will be extended from the biological to the cultural realm. From Poppers' and Eccles' 'Three Worlds' a role for the historian in achieving cultural stability and development will be given. It will be argued that if the individual is exposed to the significant artefacts then it may be possible to recapitulate cultural evolution synoptically. This understanding will serve as basis for an approach to the role of history in the curriculum of architectural education. From this a speculative structuring of the broad architectural curriculum will be given.

9.2 INTRODUCTION

The preceding chapters have set out an understanding of the plan-artefact and plan-style in the socio-cultural realm. Through iconographic interpretation the artefact can be ascribed to place and time and through iconological interpretation meaning ascribed. This understanding of the plan allows it a role in the teaching of architecture. But how can this be appropriately exploited?

9.3 THE CULTURAL AUTOPOIESIS OF EDUCATION

Education can be viewed systemically as the self-

regeneration, or autopoiesis, of the cultural systems of societies. How this is achieved is dependent on the complexities and skills required of that society. One dependent on the psychomotorial skills of hunting and gathering will have the young out with the elders even before they are teenagers. Western society, with its array of specialised disciplines and high demand on cognitive and analytical skills, has formalised the corpus of knowledge into curricula which are then disseminated through institutionalised learning. The young are closeted in classrooms, sometimes right into advanced physical adulthood! Yet the end goal of both is the continuation and regeneration of the cultural systems. Education is of necessity conservative and suspicious of change. It should be the overt aim of educators to maintain the status quo and suppress novelty. Only through such conservatism can a programme of education be successfully recursive and achieve cultural homeostasis. But can such educational conservatism persist?

9.4 EDUCATION AND THE DESIGN DISCIPLINES

The idea that the human being could be creative is of fairly recent import. Prior to that the creative act was reserved for the Godhead (Williams, 1981:827). Renaissance man saw himself as God made manifest on earth. His attributes were seen as parallel to those of God and bestowed upon him to carry out the duty of the Godhead by proxy. He then took unto himself the creative act, ever mindful, however, to thank (and sometimes, like Michaelangelo, chastise) his Maker for the privilege. The creative act was the revealed in the artistic enterprises and the making of the artwork was meant as a reflection of Godly creation.

The modern use of 'creative' has the sense of

'original and innovating' (Williams, 1981:82). It cannot be coincidental that the rise in interest in creativity in the latter 1960's and 1970's was synchronous with the threatened demise of the Mechanistic Paradigm. Koestler's (1962) discourse in 'The Act of Creation' set the intellectual stage for the dissemination of ideas on creativity. De Bono brought creativity to the popular imagination through his sense of 'lateral thinking' and 'thinking exercises' (a contemporary phenomenon which parallels Ignatio Lloyola's 'spiritual exercises' of the Counter Reformation!).

The teaching of creativity in the design disciplines is considered pivotal yet this is paradoxical. If teaching is meant to be culturally recursive then 'creativity' in the sense of achieving originality and innovation is subversive in educational terms. Yet in evolutionary terms novelty can lead to 'anagenesis' or 'upward evolution' which leads to improvements of all sorts, from detailed adaptations to specializations, from the greater efficiency of some major functions ... to overall advance in general organization' (Huxley, 1969:34).

The inclusion of such subversive elements may possibly signal cultural improvisation for permitting the broadening of the scope of ideas from the well of human creativity. From this might crystallize a new paradigm to encompass the wider understanding. This presumes that at some stage in cultural evolution cultural patterns will revert to a system in a state of dynamic equilibrium-'stasigenesis' or 'stabilized limitation' (Huxley, 1969:34).

There is however another possibility and that is that the pattern of human society is undergoing dramatic

evolutionary change. It is possible that, just as the mind of the individual who is constantly exposed to new environments and new challenges is always in a state of innovative alertness, so too complex societies make these individual traits part of the cultural character, the esprit dé système or spirit of the system. This will lead to psycho-cultural 'branching' or 'cladogenesis' (Huxley, 1969:34).

This supposes human society interacting as a single super-system on global scale where ideas are traded, Theilhard de Chardin's (1967) 'noospheres' stripped of its mysticism. Within this system will exist many systems of sub-cultures. Jantsch (1980:256) states it thus:

'A pluralism emerges in which many dynamic structures penetrate each other at the same level. In such a pluralism, there is no longer the familiar evolution in big step functions. Change, increasing in absolute measure, occurs ... horizontally, in a multitude of simultaneous processes, ... The reality of the human world becomes dissolved into many realities, its evolution into a multitude of horizontally linked evolutions. One may think of, the evolution of a pluralistic ecosystem ...'

We are speaking of an ecosystem of paradigms! The implications for the architectural educationalist are that we are to teach a Norman Foster and a Paolo Soleri side by side and that the system of education has to be such that both they and all others can be accommodated therein.

9.5 DEVELOPMENTAL RECAPITULATION

The human being matures more quickly than before. This is a puzzle if one thinks of puberty as the onset of fertility. In our overcrowded globe a younger fertility can surely not be a requisite. Yet puberty

does not only foreshadow a reproductive readiness but also the onset of adult intelligence. Just as biological evolution pushes back the biological clock through a technique which Haeckel (1866), the C19 German biologist, has termed 'recapitulation'.

He proposed a model of somatic recapitulation where in the embryonic stage the developing foetus 'recapitulates' the states of its evolutionary ancestry. Thus at various phases the human embryo will resemble that of fish, reptile and non-primate before becoming recognisably human (figure 9.1). But why should this pattern be restricted to the biological realm and to somatic development?

It is feasible that this recapitulation of more primitive evolutionary cultural states occurs through the long childhood which is man's. The early onset of adult intelligence is readying the individual for the wealth of cultural information to which he or she is heir. Yet if the individual is to claim that inheritance it must be made available in comprehensible form. It behoves the educationalist to consider in what manner our cultural past might be made accessible.

If cultural recapitulation is possible then the teaching of history becomes important in the cultural development of the individual in that it allows him to recapitulate on the various phases of cultural development, and specifically the realm of ideas current within those stages. These ideas then become part of his "mental toolkit".

9.6 HOLOGRAMMIC THOUGHT

The biological technique involved in equipping the

individual for encountering the world lies in stereoscopic and -phonic vision and sound respectively and brain lateralization. Perception is dependent on the brain integration of the physically distanced reception of stimuli, or stereo-aesthesia, be it through eyes or ears. Bateson (1980) terms this 'multiple versions of the world'. It would appear that man is programmed to require memory for recognition and disparity for discovery. The disparity is further extended through the lateralisation of brain function, the left brain being analytical and serial by nature, the right envisaging and integrative. This distinction allows for a diverse knowledge about the world integrated into a richer whole through the elision of these two brain types. One can use the analogy of the hologram, where two sources of the same light have to be out of phase to reveal the image. The brain would seem to require a certain disparity of understanding to construct a meaningful whole. Such integrated 'wholeness' of understanding is here termed 'hologrammic' thought.

When Lewis Carroll (1966) (alias mathematician Charles Dodgeson) asserted that the proof is only completed when stated thrice as regards the Jubjub, he, in his whimsical fashion has provided us with a useful illustration of the three ways of knowing:

'Tis the voice of the Jubjub'

'Tis the note of the Jubjub'

'Tis the song of the Jubjub. The proof is complete ...'

'Voice' is a sensorial recognition, 'note' an analytical recognition, and 'song' the totality of possible knowledge. Thus when saying "oh yes, I see" and "oh yes, I know" the student is reflecting these

types of knowledge. "Oh yes, I understand" reflects that hologrammic knowledge is attained.

A discipline, such as architecture, has the advantage of offering the student just such hologrammic insight. The discipline requires both strong analytical and representational skills. Through examining the architectural artefact the student can discover both the technical and visionary response of the author. He can thus 'see', 'know' and 'understand'.

So too with history.

Facts in themselves are at the level of knowing and occupy Panofskys pre-iconographic strata. The recognition of images carried by artefactual material occupies the iconographic strata and gives gestalt recognition. It however requires the integration of both factual and gestalt knowledge to achieve understanding and derive meaning. This is at the highest level of Panofsky's hierarchy of artefactual interpretation, the iconology of the artefact.

In teaching the history of a discipline, in this case that of Architecture, the ultimate objective is the familiarisation of the student with the field to the point where he attains independent critical faculties and fully liberated creative capacity.

It will be recognised that Bloom's (1960) taxonomy of cognition is of relevance, and that which is to be presented is a technique for aiding the senior student in reaching the higher levels of the cognitive hierarchy, namely evaluation and criticism, and particularly self-evaluation and -criticism.

9.7 TEACHING THROUGH PARADIGMS

A suitable technique for making available cultural wealth is through the paradigmatic understanding of history. If history is a sequence of paradigmatic episodes then what were once tacit directives of the prevailing paradigms of the various historic episodes can be articulated and disseminated. This requires the selection of 'meaningful' historical events, 'synchronic' manifestations of ideas across a broad spectrum of disciplines, the identification and employment of the 'significant' artefactual material and an employing of the 'deep' vocabulary. In order to present a cultural recapitulation it is necessary that the material employed is synoptic and representative. There is no room in such an approach for the trivial or the encyclopaedic.

Through the paradigmatic methodology it should not only be possible to help the maturing individual access that culture to which he is heir but also to alert him to cultures which were never personally their own. By the same token the culturally impoverished (the greater portion of the video-generation!) and the culturally disadvantaged (the greater portion of the adolescent Third World and ghetto population) might be given access to a cultural realm to which they are not direct heirs. This would assume a commonality at the biological level which allows that individuals outside of the cultural stream to which they are to be part can 'recapitulate' individually the cultural inheritance of their species. Hence cultural evolution is accelerated within the individuals own mind through exposure to significant artefactual material.

9.8 THE MIND OF THE HISTORIAN

The educator requires a hierarchy of expertise, and this expertise brings us closer to the mind of the interpreter. It is here that Popper's and Eccles' (1977) model for the interrelationship of mind and artefact proves of interest.

They propose a Three World model : World 1 is the world of 'natural' objects and is cumulative since artefacts too become part of World 1. Within Riedl's hierarchy it would be all that which 'is' even the products of 'natural' or 'biological' man. It could be considered as the World of the meme carrier since that is in effect the role of the artefact. It can be seen to be the World which is the object of interpretation in pre-iconographic analysis.

World III is the realm of abstract ideas and that world which is brought about by the cultural activity of man. It is entirely the product of the cultural strata in Riedl's hierarchy and exclusively the preserve of man. It could be called the meme pool. It too is accumulative since culture is in a dynamic state of growth and change. This is the realm of iconographic interpretation since it requires the allying of abstract ideas which are preserved in writings and ideogrammes and allegorical representations to the art object.

World II is the inner realm of mental being and is the preserve of the individual. It is unique and transitory and is directly associated with the life, experience and existence of the individual. The historian brings his personal expertise to the interpretation of artefacts which is derived from the wealth of experience and imbues them with meaning.

This is the task of iconological interpretation. It could be considered as the World of memetic en- and decoding.

From the intersection of Panofsky's processes of analysis of the artefact with Eccles' and Popper's 'Worlds', the following relationships can be established. The mind of the historian (World 2) engages the artefact (World 1) and through an identification process (World 2) discerns the iconography (World 3) of the artefactual material (World 1) and through interpretation derives meaning (World 2) to produce from known material (World 1) an iconology (World 3) which will reposit, if recorded, as additional artefactual material (World 1).

World 1 is then the repository of artefactual material produced by the culturally active, then also the writings of historians. This demonstrates the interactive nature of the historian and evolving cultural complexity of his world.

9.9 THE HISTORIAN AS CULTURAL HOMEOSTAT

The above setting-out leads to the conjecture that historians, as interceptors, decoders and interpreters of artefactual material, are functioning recursively by providing feedback to the cultural pool. It is they who return the past for re-interpretation and re-incorporation into the present cultural strata.

The discipline of history is thus seen to be dynamic within an Ecosystemic Paradigm. Rather than being the objective bystander of the Mechanistic Mindset, the historian enters the fray as active participator. History gives proxy to the 'experience' while being absent from the event. It is the extension of the

present into the reaches of the dimmest past of an emergent human intellect. Culture, as a complex system, is thereby freed from the immediate present and also from the limitations of having to gain only from directly experienced events.

It is through the agency of the artefact and the interpretation thereof that culture is disseminated and through the persistence of the artefact that culture displays temporal depth and continuity.

The distinction between the record clerk and the historian is the difference between the acts of catalogueing and that of interpreting. The interpretative role of the historian within a system of culture, far from being an academic nicety becomes an ecological necessity.

If culture can be seen to be uppermost in the hierarchy of systems of evolution, and the artefact the agency of communication within the cultural system, then the ecological role of the artefact must be admitted. As the gene, the molecule and the atom are ecological agents so too should the artefact be acknowledged as potent agent within the cultural system as the medium for transmitting memes within the cultural pool.

9.10 A SYNOPTIC HISTORY

In making ideas accessible it is necessary to employ techniques whereby these ideas are conveyed in condensed intellectual packages.

The first of these techniques is what has been termed "the paradigmatic approach" (Fisher, 1989a). This requires that history be packaged intellectually into

its relevant paradigmatic episodes and concentrated on the episodes of paradigmatic crisis. A restriction is placed on the choice of artefacts, namely that they be the unique artefacts, those which have come to be recognised as significant. The broadest spectrum of synchronous artefacts from diverse disciplines should be investigated by exploring the unique artefacts from each in order to discover common tacit directives.

9.11 SIGNIFICANT METAPHORS AND ICONS

As has been expounded in this treatise there are words in language and images in representation which have particular cultural potency through their powerful metaphorical and iconic content. It is important that these become part of the intellect of the student since once encountered they will make accessible the realm of ideas synoptically.

It is here that the plan should not be forgotten for as has been argued the plan embodies both the style and ideas of its time and as such becomes the emblem of the manner of architectural doing of its time and place.

9.12 LIBERTY THROUGH HISTORY

We have come to the end of history. We have conquered historical time by the mastering of techniques for investigating that time. Yet the study of history is now more important than ever before. What we must know of history, however, are not the facts and the details. The understanding of ourselves required an understanding of our historical selves, those forces and ideas which have moulded our contemporary understanding.

If the past is accessed in this synoptic fashion then the intellectual realm to which the individual is heir becomes rightfully theirs. Once the 'esprit de système' of each paradigmatic episode is encountered then it is in the fabric of the mind and part of the individual's intellect. The discovering through history of the realm of ideas and their context by encountering the significant artefact the relevant metaphors and symbols the individual has experienced a process of recapitulating of intellectual evolution. The paradigm revolutions of the past will be the mind revolutions of the person.

9.13 THE ARCHITECTURAL CURRICULUM IN AN ECOSYSTEMIC PARADIGM

If the preceding arguments hold then the architectural curriculum which derives from ecosystemic understanding should have two aspects as guiding principles:

1. A course structure should be determined and guided by an understanding of cultural recapitulation. Hence for an integration of coursework and sequence of presentation all teaching should have chronological time as guide to the contents of subjects and the level of problem solving. For instance early work will be the teaching of gravity mass structures, simple structural techniques and the history of early civilisations. Design briefs will require the solving of tectonic massing, exploration of symbolic form and employment of natural decorative patterns. Senior work will be more in line with the curriculum as we now know it and its emphasis on contemporary issues.

2. The second guiding principle should be the recognition of creative diversity. If we accept that the world is moving to a supra-system of paradigms operating synchronously then we are going to have not only to accept but also to encourage stylistic diversity. The strengths and weaknesses of teaching personnel will have to be made clear and staff deliberately deployed to students on the basis of their Mindsets. If pluralism is to be the nature of the emergent paradigm then it needs to be fostered from the start.

9.14 SUMMARY

Education has been explained as Society's means of cultural autopoiesis. The design disciplines teach to develop the creativity of the individual. Although creativity can be seen as being subversive of cultural stability it draws on the creative resources of the individual in fomenting cultural change. The disparate understanding of the environment, both analytically and through image has led to the formulation of the concept of hologrammic thought. It has been argued that through the employment of the plan-artefact as synoptic representative of paradigm shift or change cultural development in the individual can be accelerated through recapitulation of the cultural past. 'Significant plans, 'deep' vocabulary and 'unique' artefacts' are all necessary in a 'synoptic' history. This provides a role for the historian as cultural homeostat.

9.15 CONCLUSION

Much of what has been presented here is speculative and tentative. What is however apparent is that

education is the dynamo of any cultural system.

If that system is to flourish then the educationalists must be attuned to the emergent demands which will be made by Society. Architecture is not the elitist profession of a decadent society. It is of the oldest of Man's formal disciplines and has provided his most enduring and comprehensive artefacts. As such the discipline is heir to a wealth of ideas from historical time. These ideas can still be read from the artefacts which persist. Because of the trans-disciplinary and intercultural nature of the practice of architecture it is well placed to serve as laboratory and innovator to an emergent ecosystem.

We should not forego the opportunity.

REFERRED WORKS

- ACKERMAN, J. 1962. A theory of style. The journal of aesthetics and art criticism, vol. 20. Spring: 227-37.
- AMERICAN, 1970. The American heritage dictionary of the English language. New York: American Heritage and Houghton Mifflin.
- ARCHITECTURAL MONOGRAPHS. 1983. John Soane. London: Academy Editions.
- ARNHEIM, R. 1977. The dynamics of architectural form. Berkeley: University of California Press.
- BAKKER, K. 1991. Argetipes in Argitektuur. Pretoria: Ongepubliseerd OMG lesing, 110 Universiteit van Pretoria.
- BARNES, H. 1963. [1937]. A history of historical writings. 2nd Revised Edision. New York: Dover.
- BATESON, G. 1980. Mind and nature. London: Fontana.
- BAZIN, G. 1968. The Baroque. London: Thames and Hudson.
- BECK, H. (Ed).1985. Southern Africa. UIA International Architect. Issue 8/1985. London: International Architect Publishing.
- BEINHART, J. 1961. Amancio Guedes. Architect of Lorenço Marques. Arch. Rev., Vol. CXXIX, No. 770: 241-9.
- BELLOW, S. 1992. Saul Bellow on Mozart. The Guardian, Thursday, April 1:23
- BERG, J.H. VAN DEN. 1974 [1956]. Metabletica of leer der veranderingen. Beginselen van een Historische Psychologie. Nijkerk G.F. Callenbach B.V.
- BEUKES, W. 1992 Pretoria: unpublished OTR211 coursework. University of Pretoria.
- BLASER, W. 1965 Mies van der Rohe. Die Kunst der Struktur. Zurich: Artemis.
- BLOOM, B. 1960. Taxonomy of educational objectives; the classification of educational goals. Handbook: Cognitive domain. London: Longmans.

- BOEZIGER, W. (Ed). 1950. Richard Neutra 1923-50. Buildings and Projects. New York: Praeger.
- BONTA, J. 1979. Architecture and its interpretation. London: Lund Humphries.
- BOORSTIN, D. 1983. The discoverers. Harmondsworth: Penguin.
- BOULDON, J. (Ed). 1967. Edmund Burke. A Philosophical enquiry into the origin of our ideas of the sublime and the beautiful. London: Routledge & Kegan Paul.
- BUCHDAHL, G. 1965. A revolution in Historiography of Science. Hist.Sci., Vol.4:55-69.
- CAMESASCA, E. (Ed). 1979. History of the house. London: Collins.
- CANTACUZINO, S. 1970. Modern houses of the world. New York: Studio Vista.
- CARROL, L. 1966. The complete works. London: Nonesuch.
- CHARDIN, T. DE. 1967 [1955]. The phenomenon of man. (Translated from the French). London: Fontana.
- CLARK, K. 1974. Civilisation. London: BBC.
- COETZEE, 1992. Pretoria. Unpublished preparatory drawings for degree thesis. Department of Architecture. University of Pretoria.
- COLLINS dictionary of the english language. 1979: London: Collins.
- COLLINS, P. 1965. Changing ideals in Modern Architecture 1750-1950. London: Faber & Faber.
- DAWKINS, R. 1976. The selfish gene. Oxford: Oxford University Press.
- DREXLER, A. 1977 The architecture of the Ecole de Beaux-arts. London: Seckler & Warburg.
- DUNNING, W. 1991. Changing images of pictorial space. Syracuse: Syracuse University Press.
- DUNSTER, D. 1985. Key buildings of the Twentieth Century. Volume 1: Houses 1900-1944. New York: Rizzoli.
- EATON, N. 1949 Pretoria:uncatalogued and unpublished.

- Eaton collection. Department of Architecture, University of Pretoria.
- ETLIN, R. 1984. The architecture of death. The transformation of the cemetery in Eighteenth-Century Paris. Cambridge, Massachusetts: MIT Press.
- FARUQUE, O. 1984. Graphic communication as design tool. New York: Van Nostrand Reinhold.
- FISHER, R. 1989a. A paradigmatic approach to architectural history: postmodernism. Pretoria: Unpublished M Arch thesis, University of Pretoria.
- FISHER, R. 1989b. The Paradigm as an intellectual model. Eduction Bulletin, Vol. XXXIII, December 1989:44-50).
- FISHER, R. 1992a. Pretoria: unpublished material.
- FISHER, R. 1992b. A visual lexicon of the South African dwelling. Cape Town: Maskew Miller/Longman (in Press).
- FRESCURA, F. 1981 Rural shelter in Southern Africa. Johannesburg : Raven.
- FRIGYES, P. 1955. Belső terek művészete. Budapest: Műszaki Könyvkiadó.
- FRISCH, K. VON. 1975. Animal Architecture. London: Hutchinson.
- FROBENIUS, L. 1933. Kulturgeschichte Afrikas. Zurich:Artemis.
- GIEDION, S. 1971. Architecture and the phenomena of transition. The three space conceptions in architecture. Cambridge, Massachusetts: Harvard University Press.
- GIRLOT, J. 1962. A Dictionary of Symbols (Translated from the Spanish by J. Sage). London: Kegan Paul.
- GOMBRICH, E. 1972 Symbolic Images. Studies in the art of the Renaissance. London: Phaidon.
- GOMBRICH, E. 1979. The sense of order. Oxford: Phaidon.
- GREGORY, R. 1984. Mind in Science. A history of explanations in psychology and physics. Harmondsworth: Penguin.

- GUIDONI, E. 1978. Primitive architecture (Translated from the Italian by R. Wolf). New York: Harry N. Abrams.
- HADAS, M and EDITORS. 1966. Imperial Rome. Amsterdam: Time Life International.
- HAECKEL, E. 1866. Generelle Morphologie der Organismen. 2 Vol. Berlin: Reimer.
- HALL, M. 1987. The changing past: farmers, kings and traders. Cape Town: David Philip.
- HANSELL, M. 1984. Animal architecture and building behaviour. London: Longman.
- HOLM & HOLM. 1986 Pretoria: unpublished drawings.
- HOWELL, F. and EDITORS. 1970. Early Man. Amsterdam: Time Life.
- HUXLEY, J. 1969. Essay of a Humanist. Harmondsworth: Penguin.
- HUYGHE, R. (Ed). 1966. Larousse encyclopaedia of prehistoric and ancient art. (Translated from French). London: Paul Hamlyn.
- JAMES, W. 1907. Pragmatism. A new name for some old ways of thinking. Popular lectures on philosophy. New York: Longmans & Greene.
- JANTSCH, E. 1980. The self-organizing universe. Oxford: Pergamon.
- JONES, I. 1970a. Inigo Jones on Palladio. Vol.1. Birmingham: Kynoch.
- JONES, I. 1970b. Inigo Jones on Palladio. Vol.2. Birmingham: Kynoch.
- JUBY, M. 1992 Pretoria: Unpublished OTR221 coursework, Department of Architecture, University of Pretoria.
- JUNG, C. 1977. Memories, dreams and reflections. Glasgow: Collins.
- JUNG, C. (Ed). 1978. Man and his symbols. London: Picador.
- KAHN, L. (Ed). 1973. Shelter. Bolinas: Shelter Publications.

- KAUFMANN, E. 1968. Architecture in the Age of Reason. Baroque and Post-Baroque in England, Italy and France. New York: Dover.
- KAUFMANN, E and RAEBURN, B. 1960. Frank Lloyd Wright : writings and buildings. Clereland: Horizon.
- KNIGHTS, L. AND COTTLE, B. (Eds). 1960. Metaphor and Symbol. London: Butterworths.
- KOESTLER, A. 1962. The Act of Creation. London: Hutchinson.
- KOESTLER, A. & SMYTHIES, J. 1969. The Alpbach Symposium 1968. Beyond reductionism. New perspectives in the life sciences. London: Hutchinson.
- KOSTOF, S. 1977. The architect. Chapters in the history of the profession. New York: Oxford University Press.
- KOSTOF, S. 1985. A history of architecture. Settings and rituals. New York: Oxford University Press.
- KRAMER, S and EDITORS, 1968. Cradle of civilization. Amsterdam: Time Life International.
- KRIER, R. 1988. Architectural composition. New York: Rizzoli.
- KUHN, H. 1992. Pretoria: unpublished OTR221 coursework, Department of Architecture, University of Pretoria.
- KUHN, T. 1970. [1962]. The structure of scientific revolutions. 2nd Editions. Chicago: University of Chicago.
- LAKATOS, I. AND MUSGRAVE, A. (Eds). 1979. Criticism and the growth of knowledge. London: Cambridge University Press.
- LASEAU, P. 1980. Graphic thinking for architects and designers. New York: Van Nostrand Reinhold.
- LASSUS, J. (Ed). 1968. Album de Villard de Honnecourt. Paris: Lèonce Laget.
- LASZLO, E. 1973. Introduction to Systems Philosophy. New York: Harper & Rowe.

- LASZLO, E. 1987. Evolution. The Grand Synthesis. Boston: New Science Library.
- LE CORBUSIER. 1986 [1931]. Towards a new architecture. (Translated from the French). Mineola: Dover.
- LEDOUX, C. 1987 [1804]. L'Architecture de C.N.Ledoux. Princeton: Princeton University Press.
- LETHABY, W. 1977 [1891]. Architecture, mysticism and myth. London: The Architectural Press.
- LUCAS, F. 1974. Style. 2nd Edition. London: Camelot.
- LYOTARD, F. 1981. The postmodern condition. A report on knowledge. Manchester: Manchester University Press.
- MALESKA, E. 1983. A pleasure in words. London: Hamish Hamilton.
- MARTIENSSEN, H. 1976. The shapes of structure. London: Oxford University Press.
- MASON, R. 1969. Prehistory of the Transvaal. A record of human activity. Johannesburg: Witwatersrand University Press.
- M^CCRONE, J. 1990. The ape that spoke. Language and the evolution of the human mind. London: Picador.
- MEISS, P. VON. 1992. Elements of Architecture. From form to place. (Translated from French). London: Van Nostrand Reinhold.
- MELLER, J. (Ed). 1972. The Buckminster Fuller reader. Harmondsworth: Penguin.
- MIDDLETON, R AND WATKIN, D. 1977. Neoclassical and 19th Century architecture. New York: Harry N. Abrams.
- NORBERG-SCHULZ, C. 1971. Existence, space and architecture. New York: Praeger.
- NORBERG-SCHULZ, C. 1975. Meaning in Western architecture (Translated from the Italian by Praeger). London: Studio Vista.
- NORBERG-SCHULZ, C. 1986. Baroque Architecture (Translated from Italian). New York: Electa/Rizzoli.

- PALLADIO, A. 1980 [1555-70]. I Quattro libri dell'architettura. Milan: Edizioni il Polislilio.
- PALMES, J. (Ed). 1975. Sir Banister Fletcher's A history of architecture. 18th Edition. London: Athlone.
- PALMER, R.E. 1972. Toward a Postmodern Hermeneutics of Performance. Benamou, M. and Caramello, C. (Eds). Performance in postmodern culture. Wisconsin: Centre for Twentieth Century Studies.
- PANOFSKY, E. 1967. Studies in iconology. New York: Harper and Row.
- PAPADAKIS, A. (Ed). 1992. Modern pluralism. Just exactly what is going on? London: AD.
- PAUW, S. 1991 Pretoria: unpublished documentation.
- PENNY, 1988. Piranesi. London: Bloomsbury Books.
- PEVSNER, N. 1972. An outline of European architecture. 7th Edition. Harmondsworth: Penguin.
- POPPER, K. 1969. The poverty of historicism. 2nd Edition. London: Routledge and Kegan Paul.
- POPPER, K. and ECCLES. K. 1977. The self and its brain. Berlin: Springer.
- PORTER, T. 1979. How architects visualize. New York: Van Nostrand Reinhold.
- PORTOGHESI, P. 1968. Borromini. London: Thames and Hudson.
- PRIGOGINE, I. and STENGERS. I. 1986. Order out of chaos. Man's New Dialogue with Nature. London: Fontana.
- PUPPI, L. 1975. Andrea Palladio. (Translated from the Italian). London: Phaidon.
- RAPOPORT, A. 1969. House form and culture. London: Prentice Hall.
- RASMUSSEN, S. 1962. Experiencing architecture. Cambridge, Massachusetts: MIT Press.

- REASON, P AND ROWAN, J. (Ed). 1981. Human inquiry. A sourcebook of New Paradigm research. Chichester: John Wiley & Sons.
- RIEDL, R. 1980. Order in living organisms: a systems analysis of evolution. (Translated from the German). Chichester: Wiley.
- RIEDL, R. 1984. Biology of knowlegde. The evolutionary basis of reason. (Translated from the German). Chichester: John Wiley and Sons.
- ROSENAU, H. 1976. Boullée & visionary architecture. London: Academy.
- ROUX, S. LE, 1983 Die Moslem-tuin: Spieël van die Paradys. Lantern, Vol. XXXII, No.4:26-37.
- RYKWERT, J. 1972. On Adam's house in paradise. New York: Museum of Modern Art.
- SACKETT, J. 1977. The meaning of style in archaeology: a general model. American antiquity, vol. 42, no. 3:369-80.
- SACKETT, J. 1982. Approaches to style in lithic archaeology. Journal of anthropological archaeology, 1:59-112.
- SACRISTE, E. 1968. Huellas de edificios una coleccion de plantas de edificios dibujadas en la misma escala. Buenos Aires: Eudeba.
- SCHOLTZ, J. 1992 Pretoria: Unpublished OTR 221 coursework, Department of Architecture, University of Pretoria.
- SCOTT, J. 1975. Piranesi. London: Academy Editions.
- SHAPER, D. 1964. The Structure of Scientific Revolutions. Phil. Rev. Vol.73:8-94.
- SHERING, A. (Ed). 1922(?) Bach Christmas Oratorio. London: Eulemburg.
- SMITHES, R. 1983. The mammals of Southern Africa. Pretoria: University of Pretoria.
- SMUTS, J. 1987. [1926]. Holism and evolution. Cape Town: N & S Press.
- SPENGLER, O. 1934. The decline of the West. (Translated from the German). London: George Allen & Unwin.

- SPERRY, R. 1970. Perception in the absence of the neocortical commissures. Perception and its disorders. Association for research in nervous and mental diseases. Vol. 48. Research Publication.
- STEADMAN, P. 1979. The evolution of designs. Biological analogy in architecture and applied arts. Cambridge: Cambridge University Press.
- STEWART, D and EDITORS. 1971. Early Islam. Amsterdam: Time Life.
- TAYLOR, B. 1986. Geoffrey Bawa. Singapore: MIMA.
- THEODORESCU, D. 1980. Le Chapiteau Ionique Grec. Genève: Librairie Droz.
- THIIS-EVENSEN, T. 1987. Archetypes in Architecture. Oslo: Norwegian University Press.
- TOULMIN, S. 1982. The return to cosmology postmodern science and the theology of nature. Berkeley: University of California Press.
- VISSER, H. 1992 Pretoria: Unpublished OTR221 coursework, Department of Architecture, University of Pretoria.
- VITRUVIUS. 1984 [C1 BC]. The Architecture of Marcus Vitruvius Pollio in ten books (Translated from the Latin by J. Givitt). London: Lockwood.
- WARD, F. 1989. Images for the Computer Age. National Geographic, Vol.175, No.6, June:718-51.
- WERNER, W. 1989. J.S. Bach. Weihnachtsoratorium. Freiburg: Deutche Harmonia Mundi (accompanying booklet to C.D.)
- WHITEHEAD, A.N. 1985. Science and the modern world. Lowell Lectures 1925. London: Free Association Books.
- WILLIAMS, R. 1981. Keywords. A vocabulary of culture and society. London: Fontana.
- WITTKOWER, R. 1974. Palladio and English Palladianism. London: Thames and Hudson.

SUMMARY

An Ecosystemic rôle for architectural style: bearing 'the plan' in 'mind'

by

Roger Charles Fisher

Supervisor : Prof. Dr. D. Holm
Department of Architecture
University of Pretoria
Degree : Philosophiae Doctor (Architecture)

In this study it is argued that 'style' is the encoding of artefacts with 'memetic' content. Style is then given an Ecosystemic rôle - synchronically, being interactive in the cultural milieu, it has ecosystemic agency; diachronically, being traditive, it has ecosystemic potency. The plan is interpreted as an 'image' derived from the graphic principles of perceiving line, figure-ground and shadow pattern. A hierarchy of images is shown as being 'image, sign, symbol and icon'. The 'plan', as economic artefact characteristic of the discipline of architecture, is analysed iconographically, demonstrating that the plan-artefact has style; and iconologically supporting the argument that the plan-image can be interpreted meaningfully. The house as type is chosen as testing case and both the traditive and interactive rôles of its plan-styling is illustrated. It is speculated that the teaching of history could be exploited to enhance 'cultural recapitulation' and that the architectura curriculum could be suitably structured to accommodate this understanding.

The study is seen as being important in that:

- it furthers the metalevel of understanding derived from

the Ecosystemic school of thought of the Department of Architecture, University of Pretoria, which emphasises the heuristic, phenomenological and contextual teaching of architecture, through overt articulation. The field of application of the Metabletics of van den Berg and Kuhn's 'paradigm' are broadened and "the Paradigmatic approach to architectural history" of the candidate's preceding study is expanded.

- it demonstrated the possibilities in reading the plan and allows therefore for the identification of significant plan-artefacts and -images as source-material for study.
- it serves as model both for investigating other architectural artefacts and for similar studies.

SAMEVATTING

Die Ekosistemiese rol vir styl in argitektuur: gedagtig aan die 'plan'

deur

Roger Charles Fisher

Leier : Prof. Dr. D. Holm
Departement Argitektuur
Universiteit van Pretoria
Graad : Philosophiae Doctor (Argitektuur)

In hierdie studie word argumenteer dat 'styl' die enkodering van artefakte met 'memetiese' inhoud is. Aan styl word 'n ekosistemiese rol toegeken - sinchronies beskik dit oor ekosistemiese bemiddeling omdat dit interaktief binne die kulturele milieu is; diachronies beskik dit oor ekosistemiese latente vermoë omdat dit traditief is. Die plan, afgelei van die grafiese beginsels waardeur lyn, figuur-grond en skadupatroon waargeneem word, word as 'n beeld interpreteer. 'n Hierargie van beelde word as 'beeld, teken, simbool, ikoon' aangetoon. Die 'plan', as ekonomiese artefak kenmerkend van die dissipline argitektuur, word ikonografies ontleed waardeur demonstreer word dat die plan-artefak stileerd is. 'n Ikonologiese analise ondersteun die argument dat die plan-beeld betekenisvol vertolk kan word. As toetsteen is die huis as tipe gekies. Beide die traditiewe en interaktiewe rolle van die stilering daarvan is illustreer. Daar word spekulêr dat die onderrig van die vak Geskiedenis ter verheffing van 'kulturele herroeping' ontgin kan word en dat die argitektuur-curriculum paslik struktureerbaar is om hierdie begrip te vervat.

Die bydrae van die studie lê daarin dat:

- dit die metabegripsvlak van die ekosistemiese leerskool van die Departement Argitektuur, Universiteit van Pretoria, bevorder wat heuristiese, fenomenologiese en kontekstuele onderrig van argitektuur deur uitgesproke artikulering benadruk, bevorder. Die toepassingsveld van die Metabletika van Van den Berg en die 'paradigma' van Kuhn word verruim en die "Paradigmatiese benadering tot argitektuurgeskiedenis" van die kandidaat se voorafgaande studie uitgebrei.
- dit die moontlikhede om die plan te lees demonstreer en toelaat dat betekenisvolle plan-artefakte en plan-beelde as bronmateriaal vir studie identifiseer kan word.
- dit as model vir beide die ondersoeking van ander argitektoniese artefakte en soortgelyke studies dien.