



Common Ground

A Landscape shared between man, his
productions and nature.

by Marise Joubert

To Daniel

By Marise Joubert

Course coordinators

Dr. Arthur Barker and Prof. Piet Vosloo

Study leader

Fourie Pieterse

ABSTRACT

This dissertation investigates how a productive landscape can increase the carrying capacity of the land, by analysing and responding to the existing site and a proposed post-industrial development of the site done in 2010. The aim is to effectively communicate the influence of man's highly consumerist nature on resources and the ecology on the user group. The chosen site is located in the high-density urban context of Pretoria West, Tshwane, South Africa. The motivation of this dissertation is for the landscape to be the synergy between the existing productive entities. The strategy was to design holistically, with the objective being to include the larger systems at play. Systemic thinking, in terms of production, increases resources and the variety of resources' deliverability. The only way that a productive landscape can be resilient is to instil positive meaning in the user and, consequently, indefinite stewardship. To achieve resilience, biophilic urban design guidelines were followed to have a positive psychological effect on the user. This dissertation aims to re-address age-old theories, such as biophilia and the "Web of Life", as crucial guidelines to inform interventions for the current, real time, global and African issues relating to increasing resource demands.

SAMEVATTING

Hierdie dissertasie ondersoek hoe 'n produktiewe landskap die drae kapasiteit van 'n omgewing kan verhoog, deur om te reageer op 'n analise van die bestaande en die 2010 post-industriële voorstelling vir die Pretoria Wes kragstasie. Die dissertasie beoog om die impak wat die mens se verbruikerskultuur op hulpbronne en die ekologie het aan die gebruiker te kommunikeer. Die gekose terrein is geleë in die stedelike gebied van Pretoria Wes met 'n hoë populasie digtheid.

Die landskap beoog om die sinergie te wees tussen die bestaande produktiewe entiteite. Die strategie is om die voorgestelde sinergie van 'n holistiese oogpunt af te benader met die doelwit om die oorhoofse betrokke sisteme in te sluit

in die besluiteming. 'n Sistemiese benadering, in terme van produksie, verhoog die teenwoordigheid, verkeidenheid en lewering van hulpbronne. Die "resilience" / veerkragtiheid van die voorstelling moet verseker word deur om betekenis in die gebruiker te vestig en uiteindelik rentmeesterskap aan die gebruiker toe te dien.

Om resilience te bereik word bio-phieliese urban ontwerp riglyne gevolg om 'n positiewe psigiese uitwerking op die gebruiker te he.

Die doel van die dissertasie is om eeue-oue teorieë soos biophilica, "Web of life" ens. as krietiese riglyne te herstel in hedendaagse globale, reële tyd en Afrika kwessies, in verbad met toemende hulpbron vereistes.

In accordance with Regulation 4(e) of the General Regulations (G. 57) for dissertations and theses, I declare that this dissertation, which I hereby submit for the degree Master of Landscape Architecture (Professional) at the University of Pretoria, is my own work and has not previously been submitted by me for a degree at this or any other tertiary institution. I further state that no part of my dissertation has already been, or is currently being, submitted for any such degree, diploma or other

I further declare that this dissertation is substantially my own work. Where reference is made to the works of others, the extent to which that work has been used is indicated and fully acknowledged in the text and list of references.

Marise Joubert

TABLE OF CONTENTS

1.INTRODUCTION	1	2.3 Secondary themes	30
1.1 Background	2	2.4Integrated theories	36
1.2 Definitions	4	3. THE URBAN ENVIRONMENT	37
1.3 Site selection	6	3.1 Urban Investigation	40
1.4 Site confirmation	10	3.2 Critique of 2010 Proposal	48
1.5 Problem statement	14	3.3 Urban objective	51
1.6 Hypothesis	15	3.4 Precedent studies	69
1.7 Research methodology and Research questions	16	3.5 Urban response on Framework level	75
1.8 Client and user identification	17	4. CONCEPT EVOLUTION	83
1.8 Limitations and delimitations	18	4.1 General intentions	84
1.9 Intent	19	4.2 Specific intentions	85
2.THEORETICAL PREMISE	21	4.3 Spatial/Architectural intentions	87
2.1 Introduction	22	4.4 Concept terms	88
2.2 Main themes	23		

5. DESIGN DEVELOPMENT	99	6.5. Site Sustainability Rating	183
5.1 Master plan site	100	7. FINAL PRODUCT	189
5.2 Understanding the site	101	7.1 Final presentation	190
5.3 Precedent studies	108	7.2 Model photographs	202
5.4 Design response	114	7.3: Conclusion	204
		8. APPENDIX	205
6. TECHNICAL INVESTIGATION	135	8.1 Water calculations	206
6.1 Introduction	136	8.2 Economic Module	214
6.3 Space for humans	138	8.3 SBAT/SSI inputs	215
6.4 Space for production	152	9. BIBLIOGRAPHY	222
6.5 Space for nature	159		
6.4 Edge conditions/ interface	174		

LIST OF FIGURES

Chapter 1

Figure 1: Racial population density of Tshwane according to census data 2011 (Frith, 2013)	2
Figure 2: Existing productive sites around Tshwane (Author, 2014).	7
Figure 3: Possible sites (Author, 2014).	9
Figure 4: Conceptual diagram of the city from west to east indicating the divide caused by the site (Author, 2014).	11
Figure 5: The framework site is indicated in relation to Tshwane and to the CBD (Author, 2014).	12
Figure 6: Panoramic photo taken from the administration building towards the west displaying the productive nature of the site (Author, 2014).	12

Chapter 2

Figure 7: Theoretical diagram indicating the key objectives which fuelled the theoretical works cited (Author, 2014)	22
Figure 8: Structured terrarium versus unstructured bushveld (Author, 2014).	24
Figure 9: Qinhuangdao Botanic Garden by Turenscape represent the geology of the nearby mountain range and the use of the colour red in response to the architecture in the vicinity (Landezine, 2012).	25
Figure 10: Periphery vision (Author, 2014)	28
Figure 11: Resilience seen in as multifunctional land uses interconnected. Image adapted from (Mehaffy & Salingaros, 2013) and (Heijden, 2013).	30
Figure 12: Image compilation of the book cover of the new science of cities indicating cities as an intertwined organism (MIT Press, 2014) under a microscope (Science Fried Art, 2014).	32
Figure 13: Image displaying ecological decline being an intangible problem (Author, 2014).	33
Figure 14: image displaying theoretical premise of man in relationship with nature (Author, 2014).	34
Figure 15: : Patterned aged concrete, illustrating the beauty of weathered environments, in contrast with newly-laid concrete (Author, 2014)	35

Chapter 3

Figure 16: Framework location (Author, 2014)	39
Figure 17: Timeline of the site (Author, 2014)	40
Figure 18: view towards south from bridge	41
Figure 19: : View towards East from productive complex (Author, 2014)	41
Figure 20: View towards south (Author, 2014)	41
Figure 21: View towards west from internal road (author, 2014)	41
Figure 22: view towards south (Author, 2014)	41
Figure 23: View towards the west from internal road (Author, 2014)	41
Figure 24: Site structures (Author, 2014)	42
Figure 25: : Existing land-use surrounding Pretoria West Power Station (Author, 2014)	43
Figure 26: Existing Power plant site features (Author, 2014)	44
Figure 27: Barrier between east and west created by the site (Author, 2014)	44
Figure 28: : Conceptual diagram of intentions for the framework by the Framework group 2010 (Smit, 2010).	45
Figure 29: Framework proposal by the 2010 framework group (Smit, 2010)	47
Figure 30: Base map constructed from the individual interventions from the framework group 2010 (Author, 2014)	47

Figure 31: The boundary acting as a separation due to energies focused on the east. The material differences between east and west also become part of the boundary (Author, 2014)	48
Figure 32: Identities on either side of the boundary is combined within the boundary (Author, 2014).	49
Figure 33: : Identities on either side of the boundary are combined within the boundary (Author, 2014)	50
Figure 34: Urban objective (Author, 2014)	52
Figure 35: Movement response to the framework group (Author, 2014)	53
Figure 36: The networks of productions on site, where the grey inputs and outputs indicate where resource management is required (Author, 2014)	54
Figure 37: Proposed networks in response to existing (Author, 2014)	55
Figure 38: A summation of the proposed programme (Author, 2014)	56
Figure 39 : Investigation of framework programme locality (Author,2014)	57
Figure 40: Requirements for bamboo production (Author, 2014)	58
Figure 41: Water treatment requirements (Author, 2014).	60
Figure 42: Horse habitat requirements (Author, 2014)	62
Figure 43: Timber and textile buy-back centre (Author, 2014)	63
Figure 44: Food production requirements (Author, 2014)	64
Figure 45: Movement diagram on site (Author, 2014)	65
Figure 46:Hierarchy of the productive programme (Author,2014)	66
Figure 47: Hierarchy of the public spaces (Author 2014)	66
Figure 48: Hierarchy of the the combined categories programme (Author,2014)	66
Figure 49: Site opportunities (Author, 2014)	67
Figure 50: Site constraints (Author, 2014)	68
Figure 51 View of Charlotte Maxeke Street	68
Figure 52: View of seepage through retaining wall(author,2014)	68
Figure 53: Artist's rendering of the Twisted Valley (Landezine / Landscape Architecture Works, 2014)	70
Figure 54: Figure ground of city with Twisted Valley proposed intervention (Landezine / Landscape Architecture Works, 2014)	70
Figure 55: Route seen as an entity of its own connecting the two sides of the river (Author, 2014)	71
Figure 56:Photograph of walkways up the steep slopes around the Vinalopo River (Landezine / landscape architecture works, 2014)	71
Figure 57: Photograph of walkways crossing the channelled Vinalopo Rriver (Landezine / Landscape Architecture Works, 2014)	71
Figure 58: An indication of the route's multifunctional use in a lower income community (Landezine / Landscape Architecture Works, 2014)	71
Figure 59: Urban intention / framework master plan indicating the extent of the urban spine that the river can create (Landezine/ Landscape Architecture Works, 2014)	71
Figure 60: Community members enjoying the pier (Landezine / Landscape Architecture Works, 2014)	72
Figure 61: Pathway that connects the whole precinct, serves as a main pedestrian artery (Landezine/Landscape architecture works, 2014)	72
Figure 62: Community interests included in the landscape (Landezine / Landscape Architecture Works, 2014)	72
Figure 63: Central network connects with surrounding fabric (Author, 2014)	72
Figure 64: Variety of activity along the water edge creates interest (Landezine/Landscape architecture works, 2014)	73
Figure 65: Aerial view of completed project(Landezine/Landscape architecture works, 2014)	73
Figure 66: Conceptual drawings showing intent for dwelling, movement and green open space(Landezine/Landscape architecture works, 2014)	73
Figure 67: Plan of precinct indicating a ringroad which connects the precinct to the rest of the city (Landezine/Landscape architecture works, 2014)	73

Figure 68: Social spaces created within the productive landscape (Turenscape, 2004)	74
Figure 69: Productive landscape complimentary to existing architecture (Turenscape, 2004)	74
Figure 70: Students partaking in the harvest process (Turenscape, 2004)	74
Figure 71: The system's concept and productive design development (Turenscape, 2004)	74
Figure 72: Layered response to possible program (Author, 2014)	75
Figure 73: Proposed land uses (Author, 2014)	76
Figure 74: Urban objective diagram indicating the site, which becomes the element linking the east and the west (Author, 2014)	77
Figure 75: Conceptual layout of route on site (Author, 2014)	77
Figure 76: Conceptual hierarchy of route (Author, 2014)	77
Figure 77: vision image of entrances and landings (Author, 2014)	78
Figure 78-82: Figure series indicating route typology (Author, 2014)	79
Figure 83: Proposed movement (Author, 2014)	79
Figure 84: Interaction points on site	80
Figure 85: Final framework(Author, 2014)	81
Chapter 4	
Figure 86: Conceptual diagram of humans understanding the system (Author,2014)	84
Figure 87: Vision image of productive landscapes combined with public space (Author, 2014)	86
Figure 88: User's linear construct of time (Author, 2014)	88
Figure 89: Biodiversity and production's cyclic construct of time (Author, 2014)	88
Figure 90: Time as a linear construct is in contrast with cyclical time (Author, 2014) Image adapted from Adaptable Futures, toolkit Do1 :integrating context.	89
Figure 91: Processes within the bamboo production that will inform space (Author, 2014)	90
Figure 92: Exploration of Francis DK Ching's path to space relationship (Author, 2014)	91
Figure 93: The path to space relationship as indicated through the concept of enthalpy (Author, 2014)	92
Figure 94: Parti diagram (Author, 2014)	97
Chapter 5	
Figure 95: Master plan site identification (Author, 2014)	100
Figure 96: Levels of master plan site (Author, 2014)	101
Figure 97: Existing fabric adapted by Author (2014) from Davey (2010)	102
Figure 98: Proposed programme (Author 2014)	103
Figure 99: Circulation(Author 2014)	104
Figure 100: Guiding people through the site (Author, 2014)	105
Figure 101: Waterfront becomes transitional space between urban and events landscape, which reads as a softer landscape (Author, 2014)	105
Figure 102 Vehicular movement(Author, 2014)	105
Figure 103: Masterplan iteration 4(Author, 2014)	105
Figure 104 : Final master plan n.t.s (Author, 2014)	106
Figure 105: Artificial valley created by Turen scape as an educational tool to educate users of surrounding geology (Landezine/ landscape architecture works, 2012)	108
Figure 106: Shading structures designed to accommodate climbing plants (Landezine/ landscape architecture works, 2012)	108
Figure 107: Definition between spaces emphasises different spaces communicating different ideas (Landezine/ landscape architecture works, 2012)	108
Figure 108: Turenscape uses colour in homogenous spaces to create interest (Landezine/ landscape architecture works, 2012).	109

Figure 109: Axis of soil displaying different soil types from rocky to loam(Landezine/ landscape architecture works, 2012)	109
Figure 110 Pathways and bridges are designed to connect interest views (Landezine/ landscape architecture works, 2012)	109
Figure 111: Artificial valley created by cutting out of artificial mound (Author, 2014)	109
Figure 112: Photograph of corroded metal pipes on site (Author, 2014)	110
Figure 113: Photograph of concrete presence (Author, 2014)	110
Figure 114: Red clay bricks on site (Author, 2014)	110
Figure 115: Coal on site (Author, 2014)	110
Figure 116: Water on site (Author, 2014)	110
Figure 117: Vertical metals on site (Author, 2014)	110
Figure 118: Diagram of different landscape identities assisting in the educational value of the landscape (Author, 2014)	111
Figure 119: Tributary Rivers flowing to the water body is a clear conceptual driver seen in this image (Landezine/Landscape architecture works, 2014)	112
Figure120: Sculptures are an extension of the forest concept (Landezine / Landscape Architecture Works, 2014)	112
Figure 121: Mounds create the perception of a natural landscape (Landezine/Landscape architecture works, 2014)	112
Figure 122: Natural materials contrasted with synthetic shaped concrete (Landezine/Landscape architecture works, 2014)	113
Figure123: The marble wall defines the edge of the park (Landezine/Landscape architecture works, 2014)	113
Figure 124: Vines crawling up the side of a tree is suggested in the green wall as an extension of the forest concept (Landezine/Landscape architecture works, 2014).	113
Figure 125: A TROP section adapted to portray the seclusion achieved by the design of the forest @ Pyne (Author, 2014)	113
Figure 126: Spatial relationship diagram n.t.s(Author, 2014)	119
Figure 127: Accommodating the main movement through the site (Author, 2014)	120
Figure 128:Creating a series of occuiable spaces. Which means creating seating, orientation points and shaded areas (Author, 2014)	120
Figure 129: Connection to upper level (Author, 2014)	120
Figure 130: Accommodating entrances to buildings and viewing building functions (Author, 2014)	121
Figure 131: Public space shared with bamboo crop (Author, 2014)	121
Figure 132: Proposed bamboo drying structure (overhead) (Author, 2014)	121
Figure 133: Conceptual Section A-A n.t.s (Author, 2014)	120
Figure 134: Proposed bamboo drying structure in 3D (overhead).	121
Figure 135: The channel is a constraint as it prohibits movement between square and waterfront (Author, 2014)	122
Figure 136: Steps are tapered according to the shape of the channel (Author, 2014)	122
Figure 137: Zero depth water feature tapered according to the shape of the channel (Author, 2014)	122
Figure 138: The channel is a constraint as it prohibits movement between square and waterfront (Author, 2014)	122
Figure 139: Organic waterfront edge is more appropriate as a transitional space between the events park and the square. (Author, 2014)	122
Figure 140: Sketch plan True height 1329m n.t.s. (Author, 2014)	125
Figure 141:Sketch plan section AA. (Author, 2014)	126
Figure 142:August Bamboo harvest(Author, 2014)	128
Figure 143:August- November drying, closed shutters (Author, 2014)	128
Figure 144: November - February Shutters closed accoriding to user need and new culm growth (Author, 2014)	128
Figure 145: February -August open shutters (Author, 2014)	128
Figure 146: Perspective view of Square, Looking West (Author, 2014)	129
Figure 147: Section B-B n.t.s (Author, 2014)	130

Chapter 6	
Figure 148: : Man part of space through peripheral vision and perception (Author, 2014)	136
Figure 149: User encapsulated in space to address approach(Author, 2014)	136
Figure 150: Transparency of productions for educational value and user comfort in an intimidating urban environment (Author, 2014)	136
Figure151: Montage of technical intent (Author, 2014 2014)	137
Figure 152 : Base line Shadow study of the sketchplan area (Author, 2014)	138
Figure 153: Layered shadows on the site. deepest blue indicating mostly shaded areas (Author, 2014)	139
Figure 154: Layered sun areas. Deepest red are areas most exposed to sun throughtout the year (Author, 2014).	139
Figure 155: Summer hottest areas (Author, 2014)	140
Figure 156: Winter, coolest areas (Author, 2014)	140
Figure 157: Where the areas overlap changeable design intervention is required (Author, 2014)	140
Figure 158: Areas requiring permanent shade structures. (Author, 2014)	141
Figure 159: Areas crucial for human comfort. (Author, 2014)	141
Figure 160: Waterfront shade concept (Author, 2014)	142
Figure 161: Node shade concept (Author, 2014)	142
Figure 162: Square shading concept (Author, 2014)	142
Figure 163: Operational Lighting (Author, 2014)	144
Figure 164: Aesthetical Lighting (Author, 2014)	144
Figure 165: Emergency Lighting (Author, 2014)	145
Figure 166: Lighting (Author, 2014)	145
Figure 167: Lighting applied to section B-B(Author, 2014)	146
Figure 168: Signage concept (Author, 2014)	148
Figure 169: Signage and bollard concept (Author, 2014)	149
Figure 170: Cut section through seating in square (Author, 2014)	150
Figure 171: Construction exploded view of seating and detail n.t.s(Author, 2014)	151
Figure 172: Different land uses on watershed (Author, 2014)	152
Figure 173: Proposed water watershed (Author, 2014)	153
Figure 174 : storm water diagram (Author, 2014)	155
Figure 175: water channel edge concept (Author, 2014)	156
Figure 176 : Locality section (Author, 2014)	156
Figure 177: Re-appropriated channel (Wetland channel) (Author, 2014)	156
Figure 178: Section and axonometric cut section through wetland/existing water channel (Author, 2014)	157
Figure 179: Bamboo process on in landscape (Author, 2014)	158
Figure 180:Arundo durax (Author, 2014)	159
Figure181: Arundo durax(Author, 2014)	159
Figure182: Peonix canariensis (Author, 2014)	159
Figure 183: Planting approach in reference with dissertation intentions (Author, 2014)	161
Figure 184: Image indicating the planting on site (Author 2014)	162
Figure 185 : <i>Bambusa glaucophylla</i> (Hankey, 2004)	164
Figure 186 : <i>Bambusa textilis</i> (Masupa, 2012)	164
Figure 187: <i>Bambusa hirose</i> (Masupa, 2012)	164

Figure 188: Bambusa balcoa (Notten, 2002)	164
Figure 189: Productive planting areas on master plan (Author, 2014)	166
Figure 190: <i>Juncus glaucus</i> (Dave, 2012)	168
Figure 191: <i>Nymphaea nouchali</i> (Notten, 2002)	170
Figure 192: Biodiversity planting areas (Author, 2014)	168
Figure 193: Planting layout lower level (Author, 2014)	170
Figure 194: Planting layout level upper level (Author, 2014)	171
Figure 195: Section A-A displaying planting application (Author, 2014)	173
Figure 196: Material palette (Author, 2014)	175
Figure 197: Locality section (Author, 2014)	176
Figure 198: Axonometric cut section through waterfront displaying piling support system for the deck (Author, 2014)	176
Figure 199: Waterfront section (Author, 2014)	177
Figure 200: Detail 1 (Author, 2014)	177
Figure 201: Detail 2 (Author, 2014)	177
Figure 202: Detail 3 (Author, 2014)	177
Figure 203: pergola 3D (Author, 2014)	178
Figure 204: Conceptual construction drawings of deck connection with existing column (Author, 2014)	179
Figure 205: Locality section (Author, 2014)	179
Figure 206: Axonometric cut section through upper deck walkway (Author, 2014)	179
Figure 207: Section through upper deck walkway (Author, 2014)	180
Figure 208: Conceptual construction drawing if ramp (Author, 2014)	181
Figure 209: 3d of construction allowing lighting to adjacent building facade (Author, 2014)	181
Figure 210: Ramp exploded section and detail drawing (Author, 2014)	182
Figure 211: Baseline SBAT/SITES rating tool (Author, 2014)	183
Figure 212: Iteration 1 of SBAT/SITES rating tool (Author, 2014)	185
Figure 213: Iteration 1 of SBAT/SITES rating tool (Author, 2014)	187
Chapter 7	
Figure 214: Panel 1 (Author, 2014)	191
Figure 215: Panel 4 (Author, 2014)	192
Figure 216: Panel 5 (Author, 2014)	193
Figure 217: Panel 6 (Author, 2014)	194
Figure 218: Panel 7 (Author, 2014)	196
Figure 219: Panel 8 (Author, 2014)	197
Figure 220: Panel 18 (Author, 2014)	199
Figure 221: Panel 15 (Author, 2014)	200
Figure 226: Southern view of Square from Fashion event building (Author, 2014)	202
Figure 227: North view of ramp against train station (Author, 2014)	202
Figure 222: View west from lower level, train station (Author, 2014)	202
Figure 228: North east view of Channel (Author, 2014)	202

Figure 223: View North East from Upper dam (Author, 2014)	202
Figure 229: View South from promenade (Author, 2014)	203
Figure 224: View East from Upper dam (Author, 2014)	203
Figure 230: View North East from Upper dam (Author, 2014)	203
Figure 225: View East from Upper dam (Author, 2014)	203
Appendix	
Figure 231: Pretoria annual precipitation (Weather world online, 2014)	206
Figure 232: South African evaporation rates (mm/a) (Schulze et al., 2008)	209

LIST OF TABLES AND GRAPHS

Graph 1 : Upper Dam's montly Yield and demand (Author, 2014)	154
Graph 2: Lower Dam's monthly Yield and demand (Author, 2014)	154
Table1: Volume of exsisting dam A (Author, 2014)	206
Table 2: Yield calculation for Upper dam : Watershed(Author, 2014)	207
Table 3: Yield calculation for Upper dam: Building complex (Author, 2014)	207
Table 4: Yield calculation for upper dam: Grey water (Author, 2014)	208
Table 5: Total yield(Author, 2014)	208
Table 6: Demand calculation for Upper dam (Author, 2014)	209
Table 7: Total demand for Upper dam (Author, 2014)	211
Table 8: Water budget balancing for Upper dam (Author, 2014)	211
Table 9: Calculation of volume of Lower dam (Author, 2014)	212
Table 10: Yield calculation for lower dam(Author, 2014)	212
Table 11: Demand calculation for Lower dam	212
Table 12: Water budget balancing for Lower dam (Author, 2014)	213

1. INTRODUCTION

1.1 Background

1.1.1 African urban densities

Approximately 41% of Africa's population will be urban dwellers by 2015. Africa has the highest urban growth rate in the world (African Planning Association, 2014). Forecasts for Africa indicate that average densities will increase from 34 to 79 persons per square kilometre between 2010 and 2050 (UN-Habitat, 2014).

1.1.2 African economic growth

By 2020, 128 million African households are projected to have progressed from a low income class to middle class, boosting consumption and spending potential, especially in capital cities (UN-Habitat, 2014).

However, 50% of Africa's current population has an income of \$1.25 US per day and the unemployment rate in South Africa is currently at 25% (Central Intelligence Agency, 2013).

1.1.3 Urban change

Future concerns include global resource constraints and the inevitable higher costs of energy, water and raw materials; in addition to the uncertainties associated with environmental and climate change (UN-Habitat, 2014). Densification is a reaction to the guarding of ecological and resource reserves. Many cities in Africa, including Tshwane, have wastelands and sprawling derelict sites with the potential to enable densification.

Urban derelict sites become a diaspora of scattered wastelands across the city. The Human Habitat report suggests that these wastelands should be designed to be habitable, to enhance densification in sprawling cities (UN-Habitat, 2014).

1.1.4 Urban unequipped-ness

Urban environments, like Pretoria West, are unequipped for the rapid urbanisation process. There is a lack of critical infrastructure such as energy, health, sanitation, water and other resources (UN-Habitat, 2014). The State of African Cities 2014 argues for an entirely new policy development, looking at opportunities for integrated urban planning, infrastructure and technologies. The argument is that there is a need for tailored site-specific in-

terventions and cooperation between interventions (UN-Habitat, 2014). Private investment groups or private-public partnerships have formed initiatives to transform and regenerate African cities. These developments have been highly criticized due to the gentrification of low-income communities (African planning Association, 2014).

Figure 1: Racial population density of Tshwane according to census data 2011 (Frith, 2013)

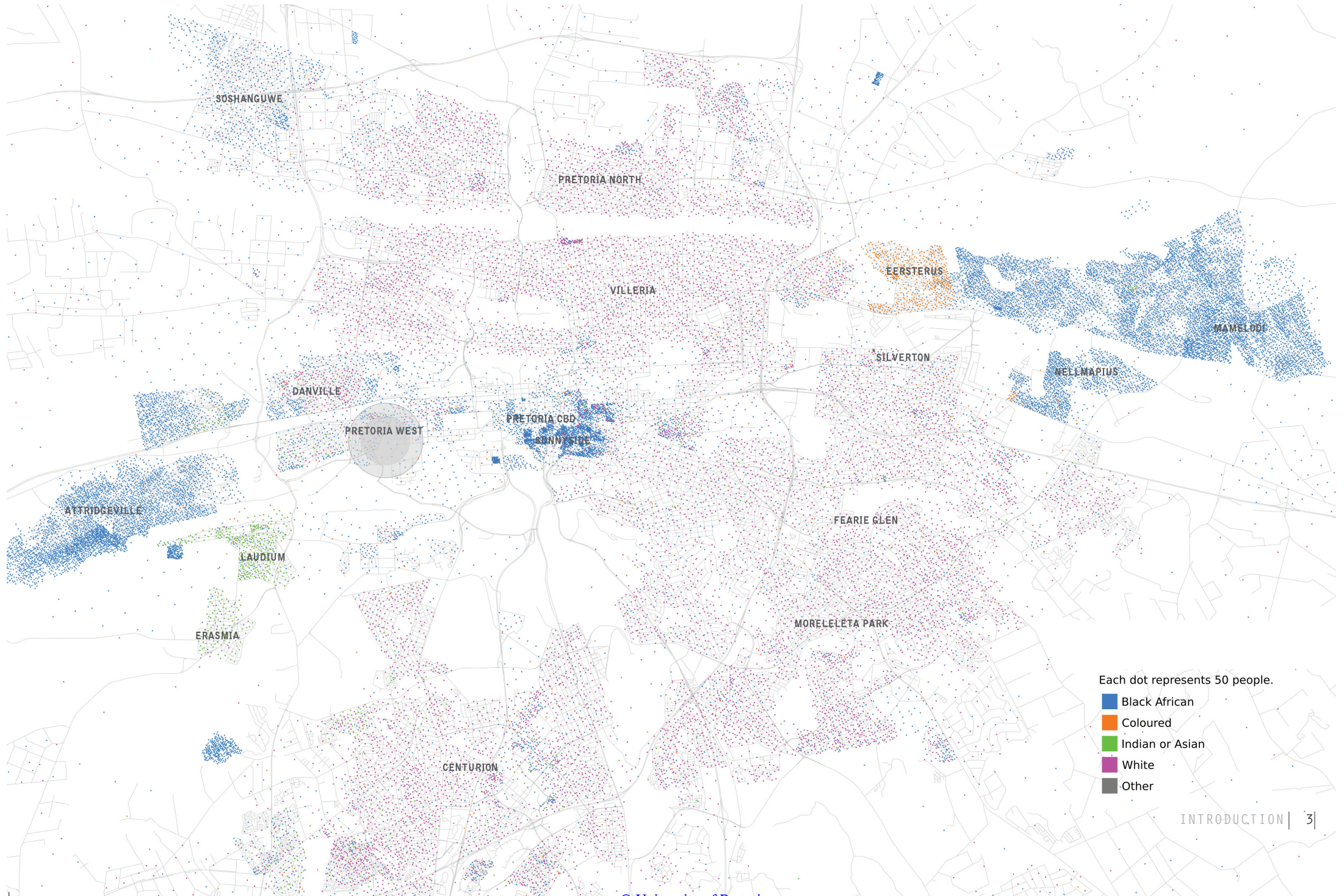

1.2 Definitions

The following theoretical concepts were used to formalise the problem statement and hypothesis:

1.2.1 Systemic approach

Systems thinking refers to the idea that all living and non-living things are connected. A systemic approach means that there is a shift from object-driven design to relationship-driven design. The term “deep ecology” sits within systems thinking. Deep ecology does not separate humans and their physical and psychological needs from the web of life (Capra, 1997).

1.2.2 Productive landscapes

An influx of people to urban environments calls for the land to be

used in an effective manner in order to respond resource demands (Wu, 2011). Productive landscapes refer to integrating the production of critical resources with conventional urban land uses to decrease the transit of resources. Productive landscapes increase the carrying capacity of the land. This means that the length of time that a population can live on one piece of land is increased. Productive landscapes need tools, planning and technology to efficiently increase their carrying capacity.

The Neolithic era for example is known for the development of human technology and tools, which resulted in agricultural activities, which terminated nomadic lifestyles (Mier et al, 2014).

This concept is synonymous with that of productive landscapes, as the objective is to sustain the life of a population for longer periods of time on a determined portion of land.

1.2.3 Biophilia

The theory of biophilic urban environments is that human habitats are designed to place people in contact with natural elements. Biophilia literally means the love for living systems. Edward O. Wilson stresses that people co-evolve with nature and that people need nature and the processes of nature in their daily lives (Newman 2014). Creating biophilic urban environments means bringing nature into all elements of urban contexts. This becomes a basic human need rather than a luxury.

1.2.4 Carrying capacity

Carrying capacity can be identified as the maximum size of a population of species that an environment can sustain given, food, habitat and water (McConnell & Abel, 2002).

1.2.5 Habitat

A habitat is the natural home or environment of an animal, plant or organism. This includes man in the web of life (Oxford University press, 2014).

1.2.6 Landscape Architecture

Landscape architecture is the design of outdoor spaces to achieve environmental, social-behavioural and aesthetic outcomes. “Landscape architecture combines environment and design, art and science. It is about everything outside the front door, both urban and rural, at the interface between people and natural systems” (International Federation of Landscape architects, 2014).

1.3 Site selection

The site was identified by investigating current productive sites in Tshwane, as illustrated in Figure 2. Productive sites were classified according to the type of production. Analysis found that unprocessed or raw resources for the city are obtained from sites situated 5 – 10km from the periphery of the urban edge. Productive sites within the urban boundaries are mainly of an industrial nature, where the processing of raw materials to semi-processed materials occurs.

Four possible sites were identified through a set of objectives or study parameters. The objectives refer to the ability of the sites to be a productive landscape and the possibility to have a positive psychological effect on the urban community.

The objectives were rated on each site individually as seen in Figure 3. The following five criteria were used to select the site:

1. Capacity to produce

Sites with larger potential areas to produce resources were given preference. Land available for cultivation was assessed in terms of slope and size.

2. Population density and access

This did not merely relate to the population density, but also to the access to the site from the surrounding neighbourhoods. The objective is to have a positive impact on the user, therefore the sites were

assessed in terms of potential interactions with surrounding users

3. Resource availability or the ability to generate resources

“Resources” in this case refers to the resources required for a landscape intervention to produce. Thus, sunlight, water harvesting potential or water availability on site were assessed.

4. Socio-economic context

Urban areas with low-income groups or sites, which displayed signs of communities with unemployment, were given preference. The objective is to make a difference in these neighbourhoods.

5. Production needs

Sites that show signs of requiring more resources were given higher priority. The factors that were taken into account were the high population density around the site, the industrial nature of the surrounding land use (which needs to process raw products) and a site that exhibits decay and degeneration.



Figure 2: Existing productive sites around Tshwane (Author, 2014).

1.4 Site selection graph

1

Site
Power station

Capacity to Produce
Population density and access
Resources availability or ability to generate resources
Socio economic context
Production needs

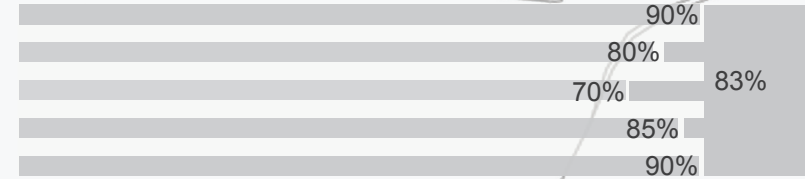

2

Daspoort waste water treatment plant

Capacity to Produce
Population density
Resources availability or ability to generate resources
Socio economic context
Production needs

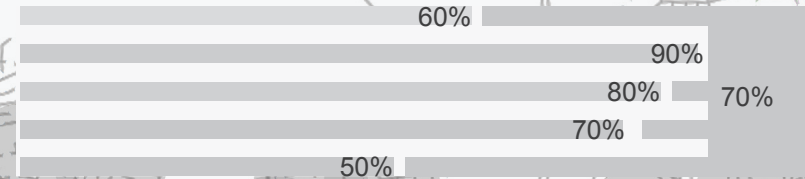

3

Steenhoven spruit

Capacity to Produce
Population density
Resources availability or ability to generate resources
Socio economic context
Production needs

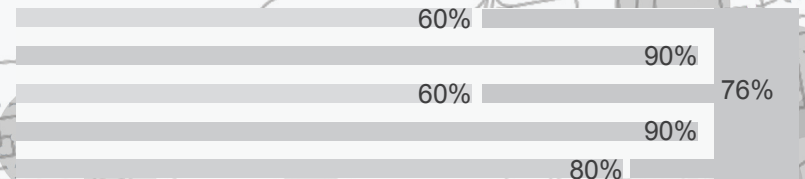

4

Skinner spruit west of Tshwane Market

Capacity to Produce
Population density
Resources availability or ability to generate resources
Socio economic context
Production needs





Figure 3: Possible sites (Author, 2014).

1.4 Site confirmation

The chosen site is situated closer to the Pretoria CBD than the other sites. In effect, less energy and resources are

required to transport goods to and from the site. Even if this is the case, the site still acts as a divide (Figure 4)

between Pretoria West and Kwag-gas Rand and Capital Park. The suburbs west of the divide are

viewed as the most rural portion of the city (Tshwane Spatial Development Framework, 2013).

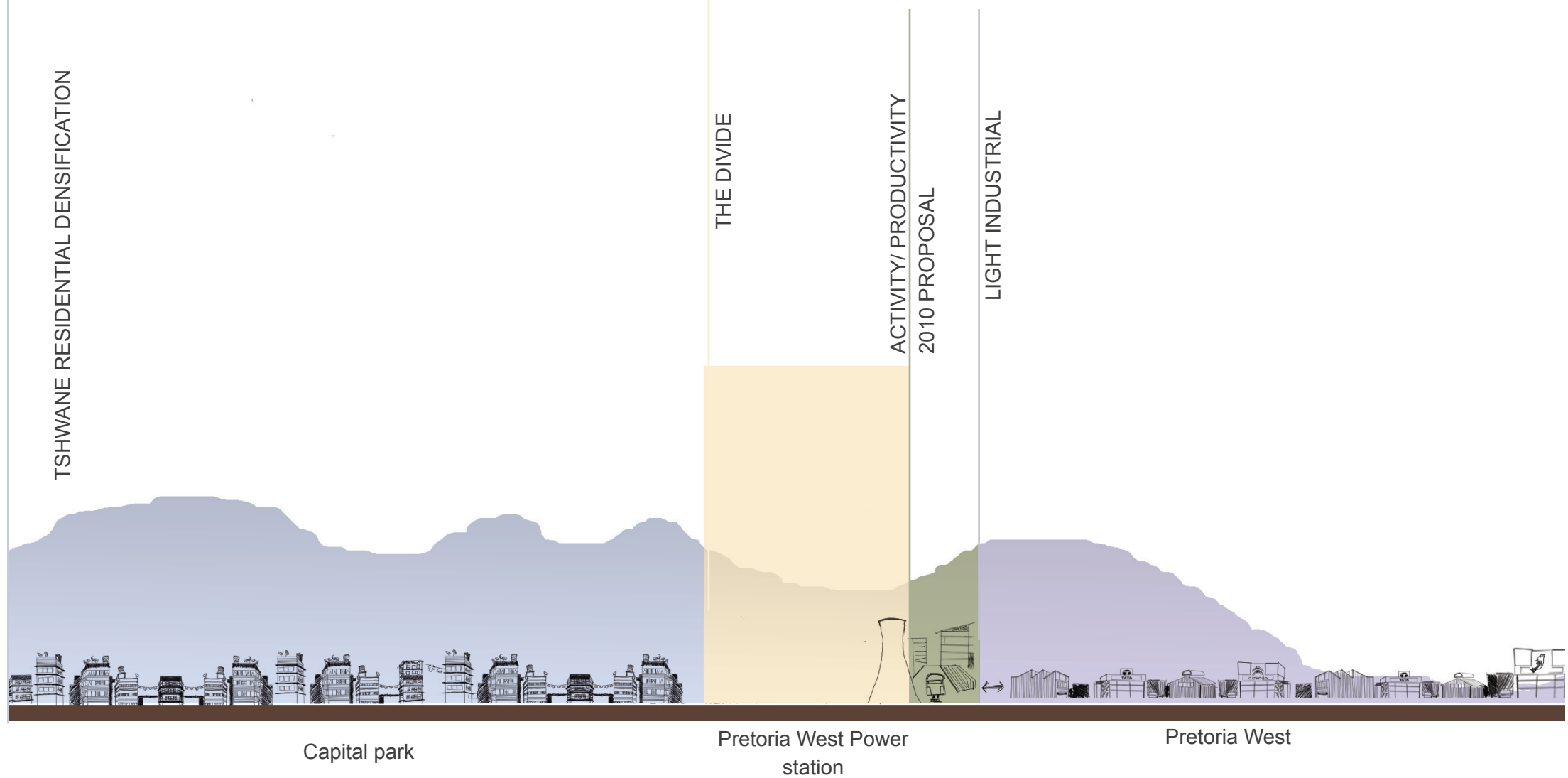

Furthermore the site is located within Region 3 of the Tshwane Spatial Development Framework (TSDF).

It is stated in the framework document that the western portion of this region is not only the most rural,

but also has a greater need of job opportunities (TSDF, 2013). The site previously provided job

opportunities and income to the region. The scale of the site has the potential to continue this legacy.

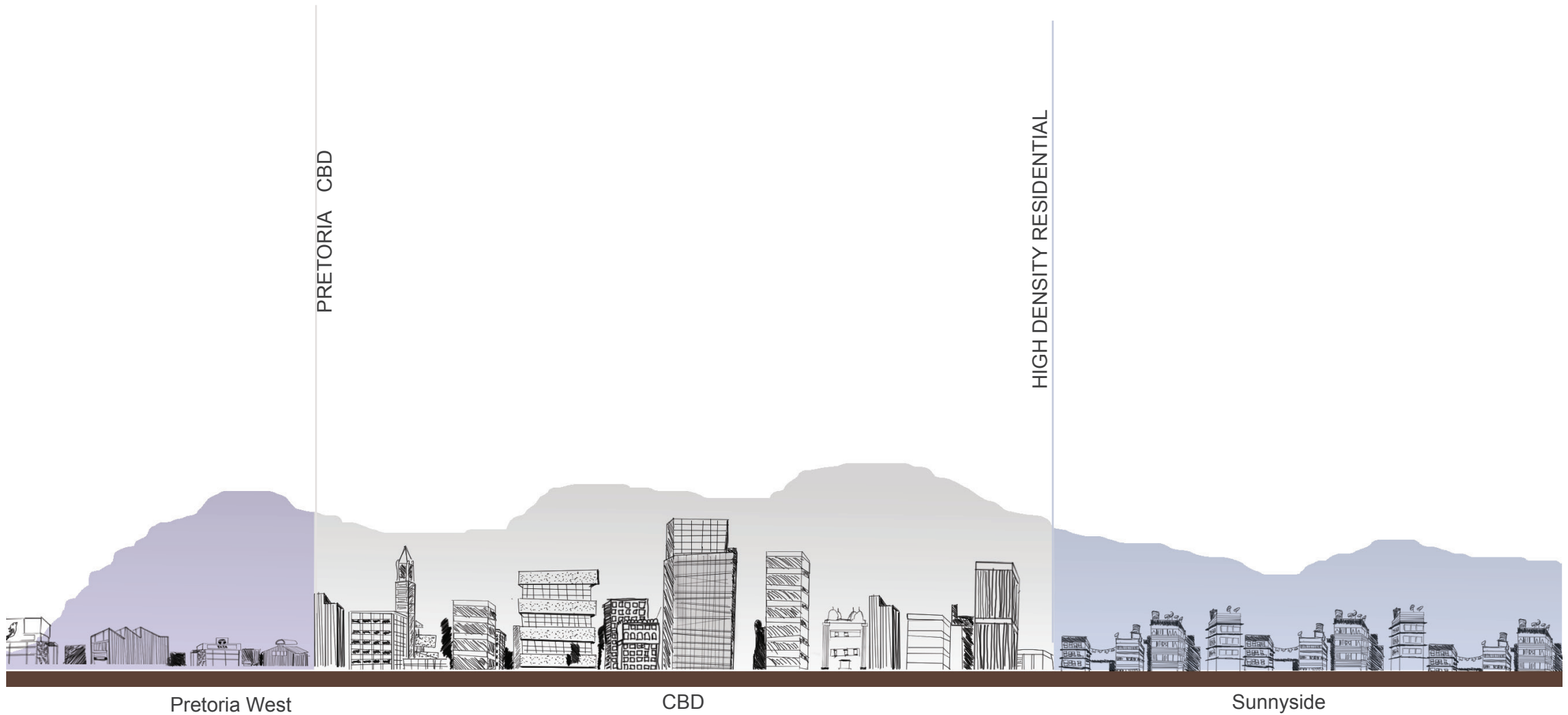

Figure 4: Conceptual diagram of the city from west to east indicating the divide caused by the site (Author, 2014).

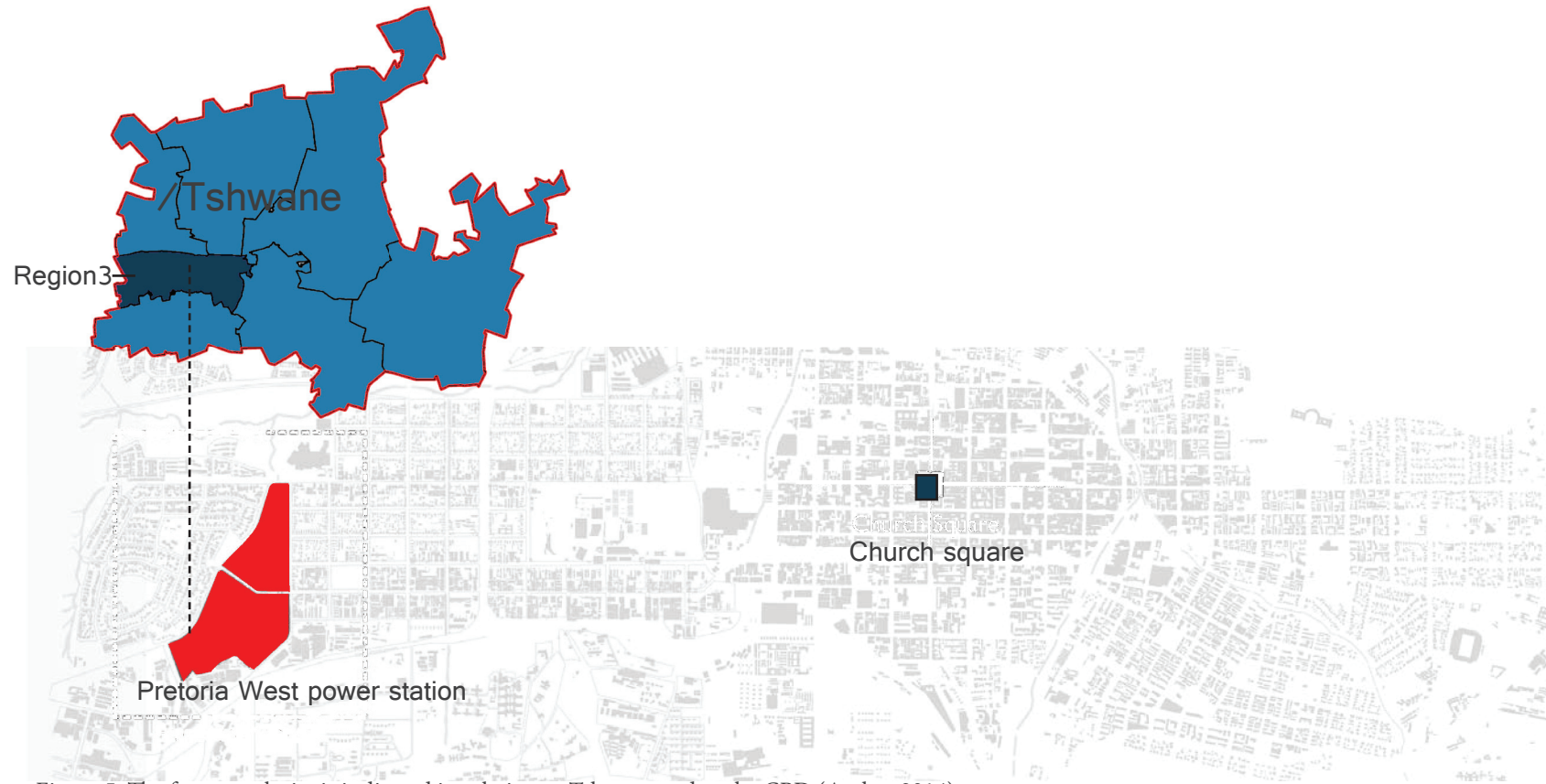

Figure 5: The framework site is indicated in relation to Tshwane and to the CBD (Author,2014).

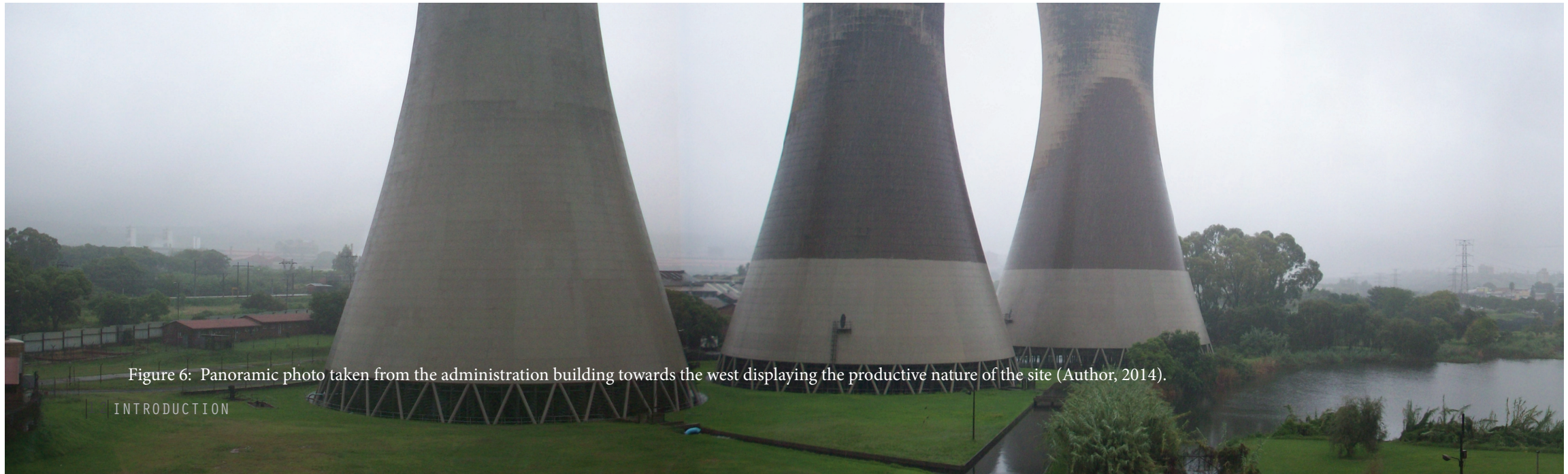

Figure 6: Panoramic photo taken from the administration building towards the west displaying the productive nature of the site (Author, 2014).



INTRODUCTION

1.5 Problem statement

1.5.1 Real world problem

As illustrated in Figure 1, a higher population density occurs around Pretoria West in relation to the rest of Tshwane's outlying areas. The surrounding high-density suburbs include Capital Park, Pretoria West, Kwagga's Rand and Atteridgeville (City of Tshwane, 2013). By 2055 more than two thirds of the world's population will be living in urban areas (African planning Association, 2014).

The city's resource demand is increasing and the carrying capacity of urban land to sustain life is decreasing. There are initiatives and urban framework proposals that react to this resource demand, but they lack synergy and the maximization of systemic interactions, operations and productions.

1.5.2 Urban Problem

Our urban centres are detached from resources production and nature. that makes it easy to be naive and just to consume. Pretoria West has an industrial character where industrial functions take preference in the urban and public realm. This results in a lack of quality habitable public spaces, which disables communities from forming neighbourhoods and developing environmental stewardship.

Future visions for Pretoria West include the densification of residential areas, especially in Capital Park, West Park and Kwagga's Rand. This will further increase the population density in this area. The Pretoria West Power Station, being an industrial site, operated in isolation. This isolation separated

the site from the surrounding urban fabric.

There is an abrupt contrast between the large-scale industrial structures and the residential buildings adjacent to the site.

1.5.3 Architectural problem

This precinct (as proposed by the 2010 framework group) has become a conglomerate of different architectural expressions. The thresholds between these expressions are not conducive to an environment that has a positive psychological effect on the user. The built precinct of the Pretoria West Power Station sits within a vast property of 48ha, which is not integrated with the surrounding functions and urban fabric. The industrial character of the site leads to a discon-

nection between the users and their perception of their ecological footprint.

I.6 Hypothesis

I.6.1 Hypothesis

Landscape architecture can be the medium through which social, ecological and productive structures are merged, in effort to educate the user on where products come from. A landscape architecture intervention will, as a response to the current Pretoria West urban environment, increase the carrying capacity of the site in support of the proposed framework. The site will become more than the mere resource commodity that it previously was, by way of achieving synergy between the productions in the landscape.

The Resilience and longevity of the intervention depends on whether the community values the landscape over an extended period. Therefore, it is crucial that the landscape communicates of the productive systems to the user group in a positive way. Biophilic design methods is used to instil a positive physiological effect on the user of the shared landscape.

1.7 Research methodology and Research questions

1.7.1 Research methodology

The research is guided by questions formed to critically analyse the socio-economic, physical, and global contexts of the site with specific reference to production-related issues. Information will be gathered by the following methods:

1. Interviews: interviews with affected parties will be held to gain knowledge about the past, and plans for the future, of the site.
2. Peer-reviewed sources: a literature study of peer-reviewed sources within the theoretical realm of the industry will be conducted. This includes precedent studies of works with similar conditions and desired outcomes.

3. Analysis conducted: The contexts will be analytically dissected in terms of the set objectives.

1.7.2 Research questions

The challenges regarding the currently evolving city are as much about process as they are about form (Inan, 2011). The research questions are formed by investigating past, current, proposed processes and how a functional landscape can be integrated into a social context for understanding:

1. How can a post-industrial site integrate into the surrounding urban fabric?

2. How can a landscape intervention improve the carrying capacity of an urban precinct?

3. How can landscape architecture introduce a biophilic urban environment into a post-industrial site?

4. Can a productive landscape be regenerative within the urban context?

5. How does a landscape intervention transform an urban environment from a singular economic commodity to a multi-faceted commodity, which increases the community's value of place, economic status and ecological sustainability?

1.8 Client and user identification

1.8.1 The client

The client is the city of Tshwane, who has plans for the rejuvenation of the Central Business District. The city of Tshwane is the owner of the Pretoria West Power Station.

1.8.2 The commercial user

Small business owners will lease the land from the city of Tshwane. The focus is placed on private companies that commercially grow bamboo. This private body will use the site for production and cultivation purposes.

1.8.3 Public user

Residents of Proclamation Hill, Westpark, Kwagga's Rand and Pretoria West, as well as existing and proposed neighbourhoods further west and east, will use this landscape. The site will provide the low-income group of Pretoria West with quality open space, economic opportunities and with a portion of their necessary resources.

1.8 Limitations and delimitations

1.8.1 Limitations

Analysis of the site

Due to the industrial nature of the site, access to the site is limited. The analysis is limited to the information available to the author.

The framework proposal done by a group of students in 2010 is assumed as existing built form for the purposes of this dissertation. Clarity of information is thus assumed according to available information, specifically regarding the final site levels. The 2010 framework group had proposed that the water pumped from the Daspoort waste water treatment facility continues its supply to the site with 1.8 mega litres of water per day. This assumption is not continued in this dissertation because the vi-

ability of the power station declined. The alternative assumption is that the water treated at Daspoort should be used for sites with higher demands.

Outcome

The results of this dissertation are not based on real-time experiments, but are tested by a panel of professionals.

Size and time

The Pretoria West Power Station is 48 ha in size. Due to time constraints, a detailed design will be done for a portion of this site only, which proves to be the most supportive of the study parameters and objectives.

1.8.2 Delimitations

Plans for the power station

The power station has not produced electricity since October 2013. The dated machinery and the size of the plant do not make it economically viable to supply electricity to the national power grid. The municipality is, however investigating alternative ways to maintain the site's function as a power station. In no way does this dissertation refer to Pretoria West Power Station as decommissioned. For this dissertation, however, the assumption is that the power station will not generate power in the foreseeable future and that proposals made in 2010 by students of the University of Pretoria will be realised.

1.9 Intent

1.9.1 Functional intent

In support of existing proposals, the intent of this study is to create a proposal that produces the maximum amount of resources in the given area by accessing the existing resource and production systems in collaboration with the urban needs of circulation, safety and infrastructural groundwork.

1.9.2 Design intent

The intent is to design an urban environment that strengthens relationships. These relationships are the relationship between man, nature and man's understanding of his integral part of the greater system; and the impact of man's consumerist nature on ecological structures and critical resources.

2. THEORETICAL PREMISE

2.1 Introduction

Chapter 2 introduces the theoretical, peer-reviewed works used to guide and inform the design process. The theoretical works cited were led by the study theme to produce resources in the high-density urban environment. Production is not the sole intention. The secondary intention is to design the environment for the user group to understand the proposed productions.

If the user understands the landscape, there is a greater chance for the user to value the landscape and its contribution to society. If the landscape can be valued in accordance with its contribution to society, it is more prone to be viable over an extended period. The aim of the theoretical investigation is to discover ways in which the system can thus be designed to achieve resilience.

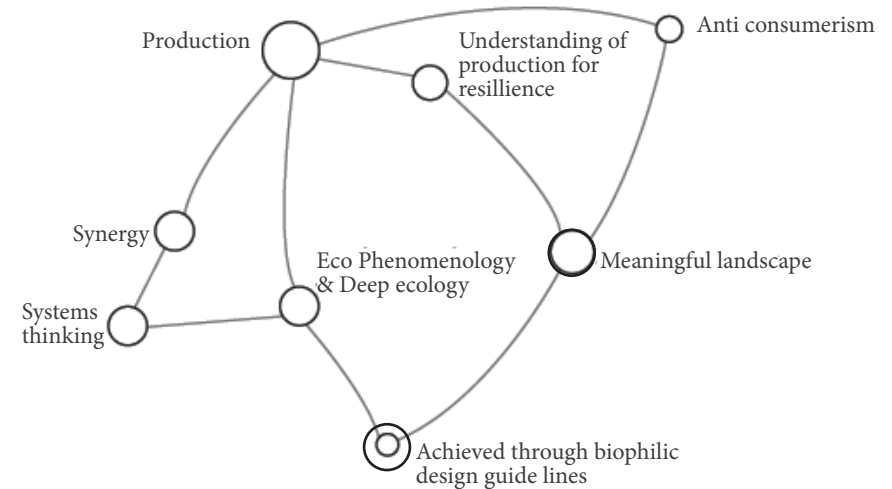

Figure 7: Theoretical diagram indicating the key objectives which fuelled the theoretical works cited (Author,2014)

2.2 Main themes

2.2.1 Biophilic cities

In contrast to the ideals of stewardship, the current world view is based on Cartesian / Newtonian ideals of people being dominant over nature. Nature and natural systems are secondary to the needs of humans. Contemporary urban design theories suggest that regenerative design solutions result from the co-evolution of human and natural systems (Cole, 2012). This theory is more than just the “green” pastiche of low energy products and relates to a living network and man’s affiliation to natural systems (Beatly, 2010).

Nature and natural elements must be included in the design of cities and buildings for a positive spatial ex-

perience (Newman & Beatly, 2013). Wilson’s definition of biophilia is the natural instinctive emotional connection that humans have with other living organisms. This natural instinct is genetic in all persons, as mentioned in the theory of deep ecology. Evidence of the power of the green qualities and features is also emerging at all scales of the urban context (Newman & Beatly, 2013). Natural systems are critical to human health, development, maturation and productivity.

Benefits of biophilic urban environments on human wellbeing

1. People living closer to open spaces have fewer health problems (Kellert et al., 2008).

2. Offices with natural lighting and natural ventilation have higher productivity rates.

3. Contact with nature has been linked to improved cognitive functioning on tasks requiring concentration, memory and healthy childhood maturation (Kellert et al., 2008).

4. Communities with higher quality environments reveal more positive valuations of nature (Kellert et al., 2008).

Designers have seen the value of including “nature” in urban environments, not just in the building designs, but also in the larger urban environments in which these buildings sit (Beatly, 2010).

Restorative environmental and biophilic design

Most sustainable initiatives have focused on low energy interventions instead of minimising harm to the natural systems (Kellert et al., 2008). Low-impact, cutting edge technology becomes obsolete in terms of resilience. True sustainability is as much about keeping a building alive as it is about creating it. It has to have positive ecological benefits during the life of the intervention.

Application of biophilic design

There are 2 dimensions to biophilic design:

1. The first refers to organic / naturalistic shapes and forms. Direct contact can be unstructured and without human impact like day light, plants' habitat and ecosystems.

Indirect contact is where nature needs human input to survive ; for example, an aquarium (Kellert et al., 2008).



Figure 8: Structured terrarium versus unstructured bushveld (Author, 2014).

2. The second dimension of biophilic design is place based / vernacular design. It responds to culture, ecology and geographic area to enhance the genius loci or meaning attached to place. It is described as “transforming inanimate matter into something that feels lifelike (Beatly, 2010). Spiritual satisfaction can be obtained from the intimate interplay of elements that form part of the unique genetics of place. Design as an extension of place becomes a tool for the comprehension of place. “Without complex knowledge of one’s place, without the faithfulness to one’s place, it is inevitable that the place will be used carelessly and

eventually destroyed” (Kellert et al., 2008).



Figure 9: Qinhuangdao Botanic Garden by Turenscape represent the geology of the nearby mountain range and the use of the colour red in response to the architecture in the vicinity (Landezine, 2012).

Within the 2 dimensions there are 6 design guidelines to materialise the biophilic theory (Kellert et al., 2008). The guidelines aid as a direct way of applying the theory within the design development chapter. Only those attributes applicable to the study objectives have been included:

1. Environmental features: this relates to basic environmental features to which humans respond positively, such as light, water, air, views etc.
2. Natural shapes and forms: Built forms inspired by nature can be translated literally or metaphorically. Natural shapes can spatially inform designs or be represented through motifs.
3. Natural patterns and processes: Humans need sensory variability. Natural patterns and processes provide this required variability, which is absent in conventional built forms.
4. Natural light and space: Complementary contrasts of light and shadow can stimulate the user. Creative manipulation of natural light fosters curiosity. People feel comfortable in spacious natural or built environments if there are sheltered, protected refuges around the edges. Spatial variability fosters intellectual stimulation.
5. Place-based relationship: Built interventions should have geographic, historical, ecological and cultural connections to place. The landscape should define the intervention's form and integrate culture and ecology.
6. Evolved human-nature relationship: The landscape should provide refuge and prospect, order and complexity, curiosity and enticement, change, attraction and beauty.

2.2.2 Meaningful landscapes

2.2.2.1 Why the landscape should have meaning

The drastic environmental decline is a popular message across various media platforms in an attempt to shift the minds of the public towards smaller ecological footprints. This message has had little impact on lifestyle changes. People respond more positively to constructive visions of change (Cole, 2012). The objective is to provide the public with a vision of positive change towards resilience, by showing them possibilities for the future.

“The taste of the apple ... lies in the contact of the fruit with the pal-

ate, not in the fruit itself” said by by Jorge Louis Borges (Butler, 2008).

The value that a productive landscape has does not lie in the landscape itself, nor in the products it delivers, but in the meaning that the user ascribes to (and connection that user has with) it.

2.2.2.2 How to instil meaning in a landscape

One of the main questions of this dissertation is how to instil meaning into a productive landscape. What is meaning within a landscape? Marc Treib says in his essay *Must Landscapes Mean?* that a landscape intervention that responds to the existing elements of place, instils a sense of

significance in the users of the place. In other words, the designer reacts to the *genius loci* (Treib, 2002). It becomes an extension of the existing; evolution rather than a revolution (German, 2006). Cultural richness further promotes local identity (Taylor, 2007).

In the case of this dissertation, the landscape has been touched and moulded by industrial functions, thus the intervention will not only have to be an evolution of the natural but also of the industrial context. In a man-made urban setting, the dominant actions of the user can promote meaning (Hester, 1995).

The most valuable of the ways to attach meaning through landscape is through the didactic approach, in which form should indicate the natural workings of the place.

According to Hester, action is one of the elements that denote meaning in the landscape. Action can be seen as a narrative when looking at daily or seasonal rituals. This especially relates to the value that people place on their everyday landscape.

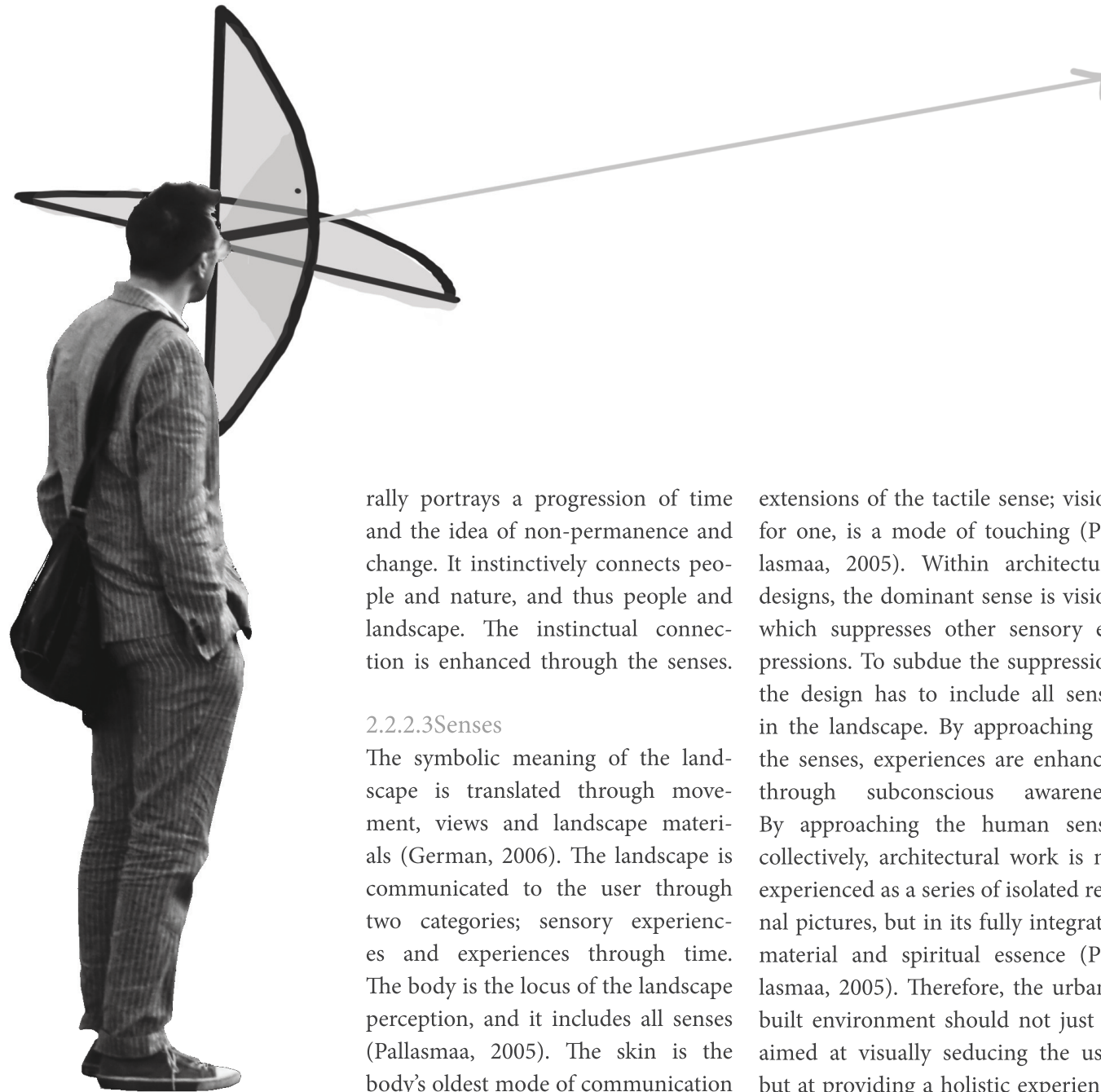

Figure 10: Periphery vision (Author,2014)
Like a narrative, the landscape natu-

rally portrays a progression of time and the idea of non-permanence and change. It instinctively connects people and nature, and thus people and landscape. The instinctual connection is enhanced through the senses.

2.2.2.3 Senses

The symbolic meaning of the landscape is translated through movement, views and landscape materials (German, 2006). The landscape is communicated to the user through two categories; sensory experiences and experiences through time. The body is the locus of the landscape perception, and it includes all senses (Pallasmaa, 2005). The skin is the body's oldest mode of communication to the psyche; touch integrates our experience of the world. All senses are

extensions of the tactile sense; vision, for one, is a mode of touching (Pallasmaa, 2005). Within architectural designs, the dominant sense is vision, which suppresses other sensory expressions. To subdue the suppression, the design has to include all senses in the landscape. By approaching all the senses, experiences are enhanced through subconscious awareness. By approaching the human senses collectively, architectural work is not experienced as a series of isolated retinal pictures, but in its fully integrated material and spiritual essence (Pallasmaa, 2005). Therefore, the urban / built environment should not just be aimed at visually seducing the user, but at providing a holistic experience.

The visual is, however, a mode through which meaning can be denoted. A direct view of an object might indicate or represent a direct relationship between a character and an important entity in a metaphor (German, 2006), but evidence indicates that peripheral vision has a higher priority in our perceptual and mental system (Pallasmaa, 2005). Peripheral vision integrates us with space, where focussed vision pushes us out of space, making us spectators, rather than part of the space.

2.3 Secondary themes

2.3.1 Resilience

The definition of resilience in this case is the ability of a system to maintain its identity in the face of internal change, external shocks and disturbances (Cumming et al., 2005). Ecological resilience is often defined at multiple scales with cross scale interactions (du Plessis, 2012). Part of the rules of resilience for built environment designs, according to du Plessis, is: to ensure a diverse urban environment, a space that can have multifunctional applications, thus be modular, clustered, flexible and reversible.

Cellular modules with a degree of versatility as a spatial design outcome offer organised complexity, which adds to the life of a city and, consequently, to its resilience, according to Jane

Jacobs in the *Life and Death of American Cities* (Helie, 2012). The concept of resilience is usually an urban design or an architectural point of departure for spatial design but has the potential to be expressed in landscape design.

Resilience is achieved through designing urban environments as complex adaptive systems, rather than monofunctional entities existing in isolation. The concept of resilience is applied to the Pretoria West Power Station that is currently an obsolete site in terms of its productive and social functions.

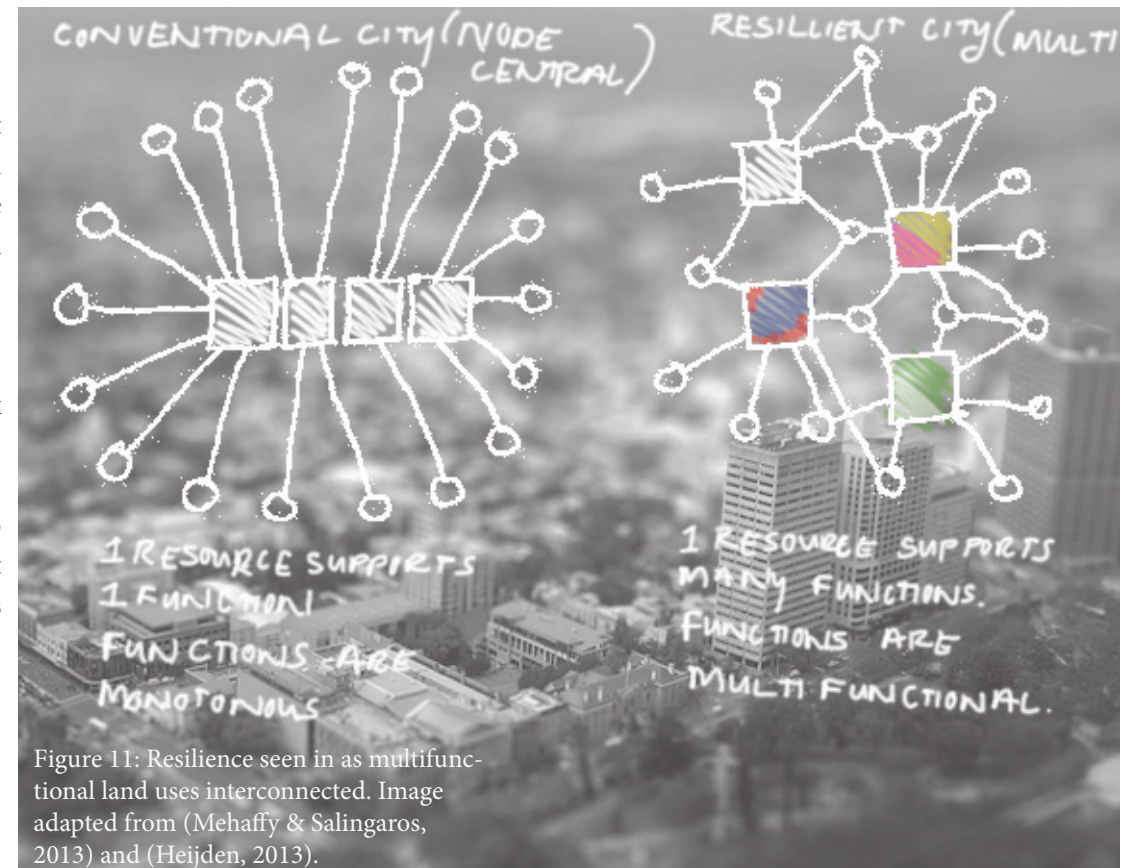

Figure 11: Resilience seen in as multifunctional land uses interconnected. Image adapted from (Mehaffy & Salingaros, 2013) and (Heijden, 2013).

The concept of resilience is used to re-purpose the obsolete sites with intentions that would avoid the degradation of the site and its surroundings in the future. The 2010 proposal for the Pretoria West Power Station is to create a mixed-use urban environment. The landscape needs to accommodate and add to the versatility of the site by allowing a certain amount of ambiguity for a variety of activities to occur. Over time, the versatility in resources and activities will ensure the longevity of the proposal.

2.3.2 Systems

The word “systems” within the urban context implies that the urban environment comprises of a series of relationships necessary for its successful function. The concept of relationships refers to changes or fluctuations between entities / objects in the city. The urban environment thus allows for such interactions.

Kelvin Campbell (2011) suggests in his book *Massive: Small, Smart Urban Rules and Guidelines* that previous urban design theories became an agent against flexibility in cities. Traditionally, cities were seen as static non-living entities in which each portion of the urban framework had an assigned function without versatility, complexity or potential for change (Cole, 2012). Tools and guidelines for urban design should rather

create the conditions for neighbourhoods to form (Campbell, 2014).

Viewing the city as a living organism enables the designer to analyse it holistically. General systems theory, as a response to the previously mentioned theories, refers to the inter-relatedness of complex systems. One element in the system is dependent on a range of other elements for survival and function (Amir Djalali, 2008).

To avoid the proposal for Pretoria West Power Station from becoming obsolete, the design resolution is approached as if the landscape is a fluctuating system that can facilitate the waves of change and interaction with its environment. Versatility in spaces responds to human needs, which will foster stewardship.

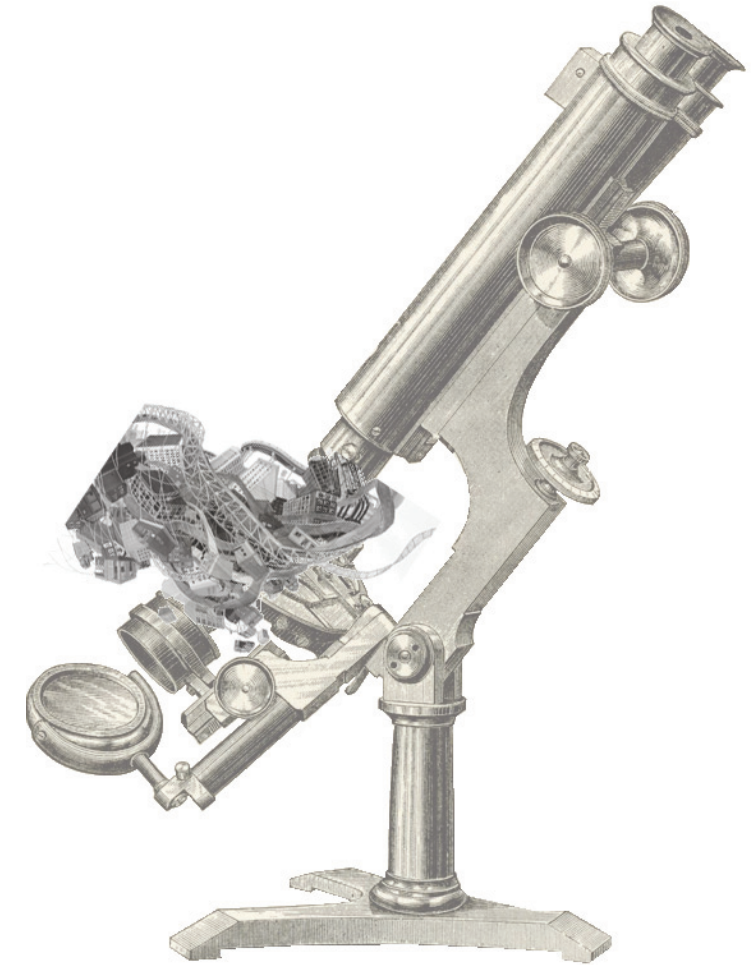

Figure 12: Image compilation of the book cover of the new science of cities indicating cities as an intertwined organism (MIT Press, 2014) under a microscope (Science Fried Art, 2014).

2.3.3 Eco phenomenology

Landscapes reflect human activity. The human culture shapes the landscape; it is a result of human ideologies (Taylor, 2007). The ordinary everyday landscape is a clue to the culture of a community. To understand the community one has to look at their everyday landscape and not just the national icons or privately owned spaces (Taylor, 2007).

The everyday landscape of Africa's urban dweller is a reflection of the community's disregard towards the natural and built environment (Amir Djalali, 2008). This disregard is prevalent in the Pretoria CBD and Western regions of Tshwane. A positive human relationship with the environment is necessary to undo the damage of environmental degradation. The design is thus proposed so as to move away from the utilitarian worldview and its consequential exploitation of the natural world (Amir Djalali, 2008).

Eco-phenomenology argues that the environmental crisis incorporates both the physical and the intangible. Everyday landscapes should be shaped according to Eastern views that landscape is an integral part of culture and are therefore inseparable from one another (Taylor, 2007). The dependency that humans have on the natural world must be made visible in the environment of everyday life and routine.



Figure 13: Image displaying ecological decline being an intangible problem(Author,2014).

2.3.4 Deep ecology

Deep ecology is a branch of environmental philosophy that considers human beings as part of environmental systems. Like humanity, the living environment has the same right to live and flourish (Amir Djalali, 2008). This theory reflects a systems approach in terms of design by expressing man's relationship with the web of life. This relationship is inherent to the human psyche.

Landscapes combine elements of space and time (Taylor, 2007), and humans inherently understand this; "we see it with our eye but interpret it with our mind and ascribe values to landscape for intangible – spiritual – reasons" (Taylor, 2007).

The contemporary term "regenerative urban design" is used as a synonym for respected endeavours of deep ecology.

Regenerative development is collectively focussed on enhancing life in all manifestations. These life forms give back more than they receive, but need man's responsibility and stewardship (Cole, 2012).

The landscape proposal has to evoke this idea of a "living landscape" with a series of layers, each able to tell a story: a human story, and of the relationships between people and natural processes (Taylor, 2007).

If Pretoria west power station is transformed into a synergetic network of

productions which integrally include man, it further manifests man's inherent relationship to the whole. The idea of man forming part of the system should be communicated to the user. The user's resources and natural systems will be directly visible and supply opportunities for interactions.

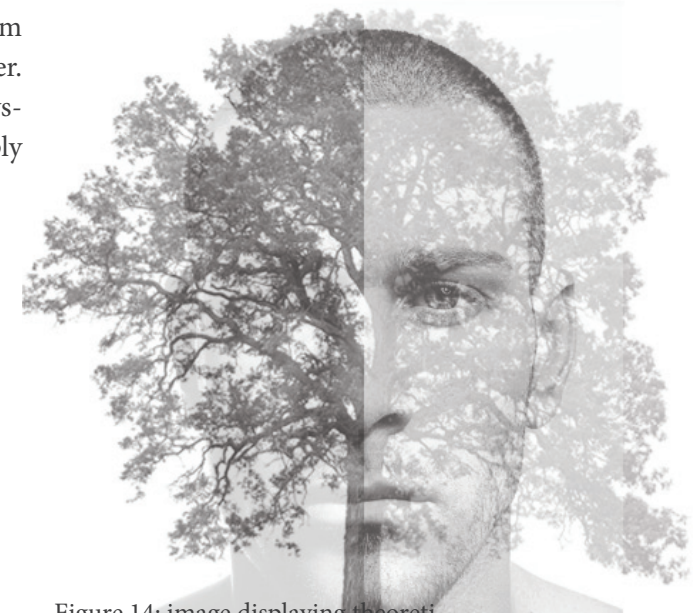

Figure 14: image displaying theoretical premise of man in relationship with nature (Author,2014).

2.3.5 A challenge to the consumerist paradigm

The term landscape has been seen as a man-made artefact since the Neolithic era because of cultural processes and values. Landscape originally referred to the clearing of forests and the introduction of fences, animals and huts (Taylor, 2007). A landscape can generate income, and is thus seen as a commodity.

Currently, urban landscapes are perceived as places for recreation, public urban spaces, or nature reserves (Armstrong, 2006). This contemporary perception causes the landscape to become one loosely connected 'sprawl'-generating entity, fuelled by a continuous desire for the new (Armstrong, 2006).

There is a constant regeneration of what is considered old, derelict and useless. Humans however are sub-consciously drawn to the transgressed qualities of derelict sites. Weathered environments are characterised by a particular intricacy associated with the embroidery of decay Humans identify with the intricacies and nature of decay. These intricacies are not present in the uniform housing and commercial developments that now occupy such spaces. The minority of designers and planners celebrate the anarchic qualities of derelict sites (Koolhaas, 2005).



Figure 15: : Patterned aged concrete, illustrating the beauty of weathered environments, in contrast with newly-laid concrete (Author, 2014)

The derelict sites have a subliminal resonance in people. By replacing everything with the new, it quickly erases the traces of failure and death (Armstrong, 2006). Artists and designers recognise such qualities (van Schaik & Golling, 2006).

Not only should the existing be recognised, but it should also challenge the consumerist paradigm. For the sake of resilience, the urban environment has to temper globalised economies. This is achieved by enabling communities to produce locally, like the 'Citteslow' / slow cities movement in Italy, where fresh produce is produced and used locally (Armstrong, 2006).

2.4 Integrated theories

According to eco phenomenology, ecological decline is directly related to humanity's relationship and value to the natural world. The aim of this dissertation is to successfully establish a positive psychological effect in the user group by creating an environment that has meaning to the user and simultaneously acts as a critical resource. The theory of biophilic urban environments can be used to create this positive psychological effect through the proposal of a productive landscape. The aim is to make the user aware of their role in the system, thereby seeing the value of synergising productions for a sustainable outcome

3. THE URBAN ENVIRONMENT

3.1 Introduction

The design extents is explored on 3 levels

1. A framework level, discussed in this chapter. This includes the entire property of Pretoria west power station.
2. A master plan level discussed in the design development
3. Sketch plan level also discussed in the design development chapter.

Figure 16: Framework location (Author, 2014)



3.2 URBAN INVESTIGATION

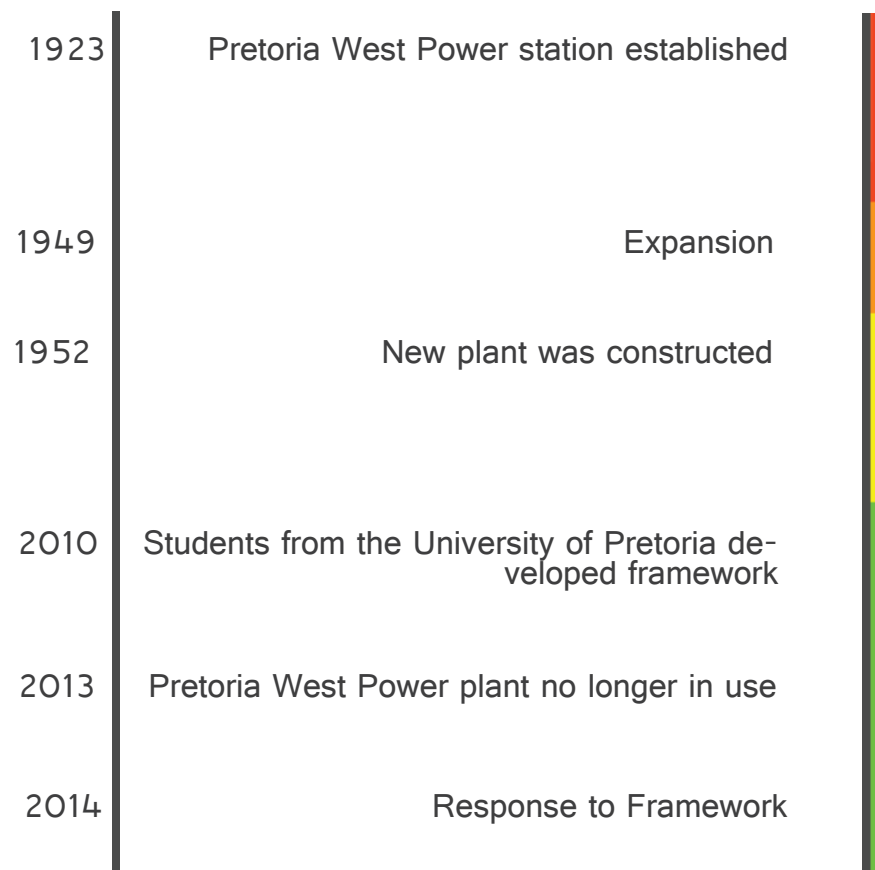

Figure 17: Timeline of the site (Author, 2014)

3.2.1 Chapter outline

The site chosen for framework response is the Pretoria West Power Station. Part 1 introduces the existing and 2010 proposals for the urban condition. The main critique of the urban condition is given in the second part of this chapter. The third part of this chapter is a response to the critique.

3.2.2 Site importance

The site acts as an identifiable landmark within the west of Tshwane. Its large structure has acted as a portal from industrial to residential since 1923. The site has a strong industrial identity visible in Figure 18-23.

3.2.3 Land use and land use potential

Smaller urban centres around the CBD of Tshwane causes sprawl and derelict sites between urban nodes. This is known as the leapfrog effect. The site is categorised as one of the derelict sites. It has the potential to be an integral part of preventing the leapfrog effect, by supporting the existing urban centre. The land use surrounding the site is distinctly different between the east and the west of the site. The west of the site includes residential and small business owners, whereas the east of the site is light industrial.

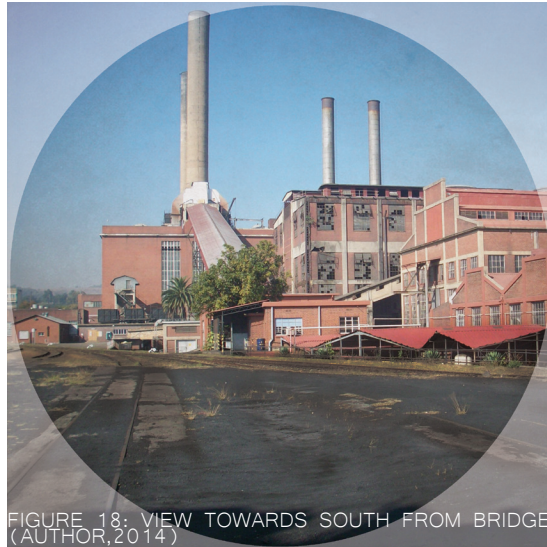

FIGURE 18: VIEW TOWARDS SOUTH FROM BRIDGE (AUTHOR, 2014)



FIGURE 19: VIEW TOWARDS EAST FROM PRODUCTIVE COMPLEX (AUTHOR, 2014)



FIGURE 20: VIEW TOWARDS SOUTH (AUTHOR, 2014)



FIGURE 21: VIEW TOWARDS WEST FROM INTERNAL ROAD (AUTHOR, 2014)



FIGURE 22: VIEW TOWARDS SOUTH (AUTHOR, 2014)



FIGURE 23: VIEW TOWARDS THE WEST FROM INTERNAL ROAD (AUTHOR, 2014)



3.2.4 Road classification

The road classification indicated in figure 25 specifies activities that can or cannot occur along that edge of the site.

- Mobility spine – Western edge of framework site
 - No direct access to adjoining land uses.
 - No on-street parking.
 - Pedestrian movement restricted.
 - Nodal development and mixed land uses (city of Tshwane, 2012).
 - Activity spine – Runs through the framework site
 - Vehicular mobility is compromised, to allow activity.
 - Pedestrian access and accessibility to land uses.
 - High-density development is promoted along routes (City of Tshwane, 2012).
 - Activity street – Eastern edge of Framework site
 - Local collector road.
 - Local economic and social amenities.
 - Mixed land uses along the side.
 - Land uses are accessible (City of Tshwane, 2012).
- The landscape can design entrances to the site on the eastern edge and along Charlotte Maxeke Street, which runs through the middle of the site.

FIGURE 24: SITE STRUCTURES (AUTHOR, 2014)

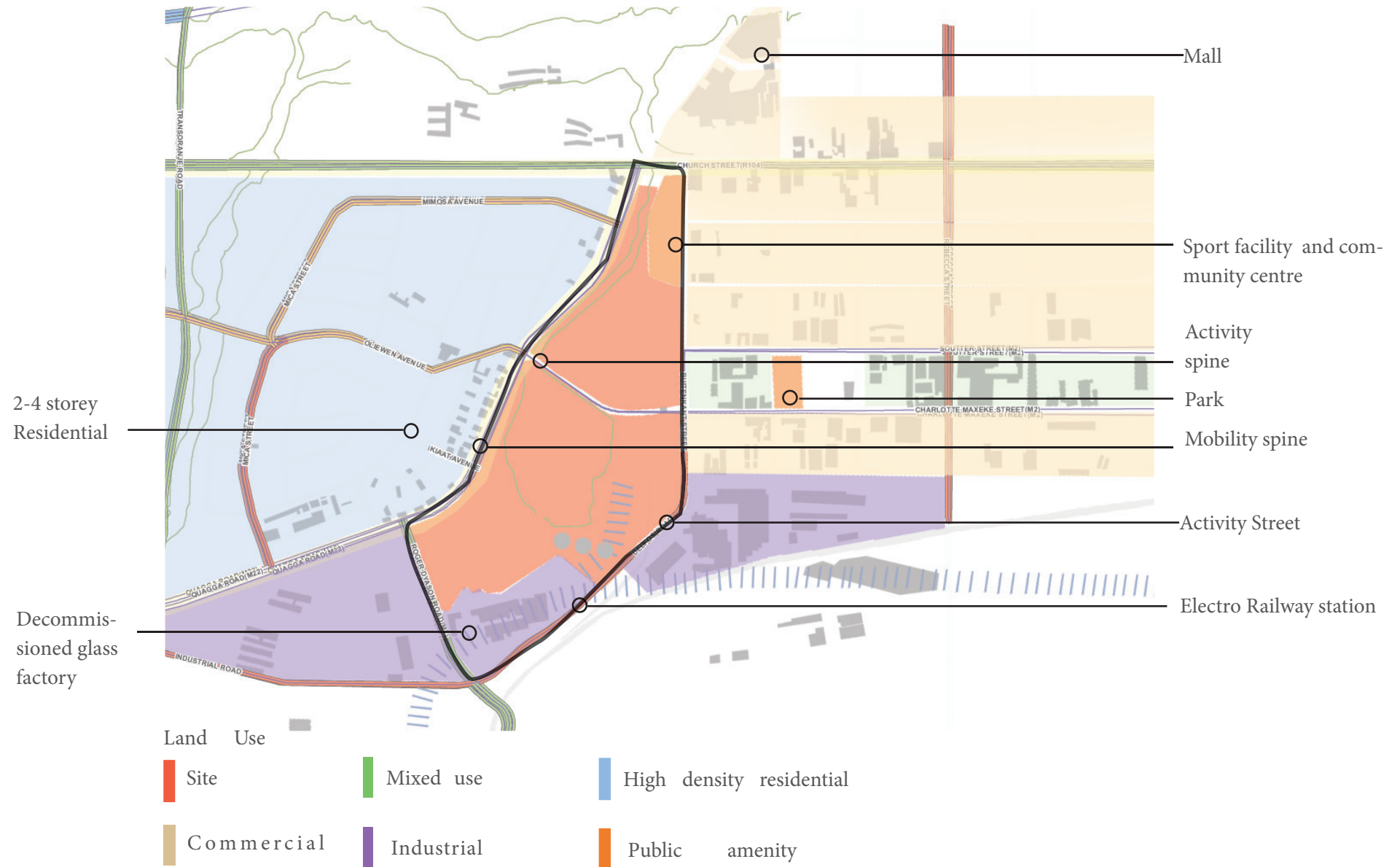

Figure 25: Existing land-use surrounding Pretoria West Power Station (Author, 2014)

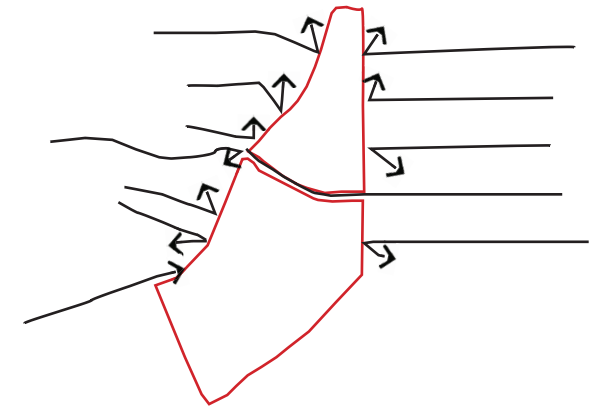

Figure 27: Barrier between east and west created by the site (Author, 2014)

3.2.5 Current site features

The current site is a coal-fired power station that has not been functioning since October 2013 because it is no longer economically viable (Masut, 2014).

The power station functioned in isolation as a demarcated space with a mono-functional program. In essence it created an impenetrable barrier, indicated in red in Figure 27. Apart from the dam visible from the street, the site is experienced as sterile and segregated from its surroundings.

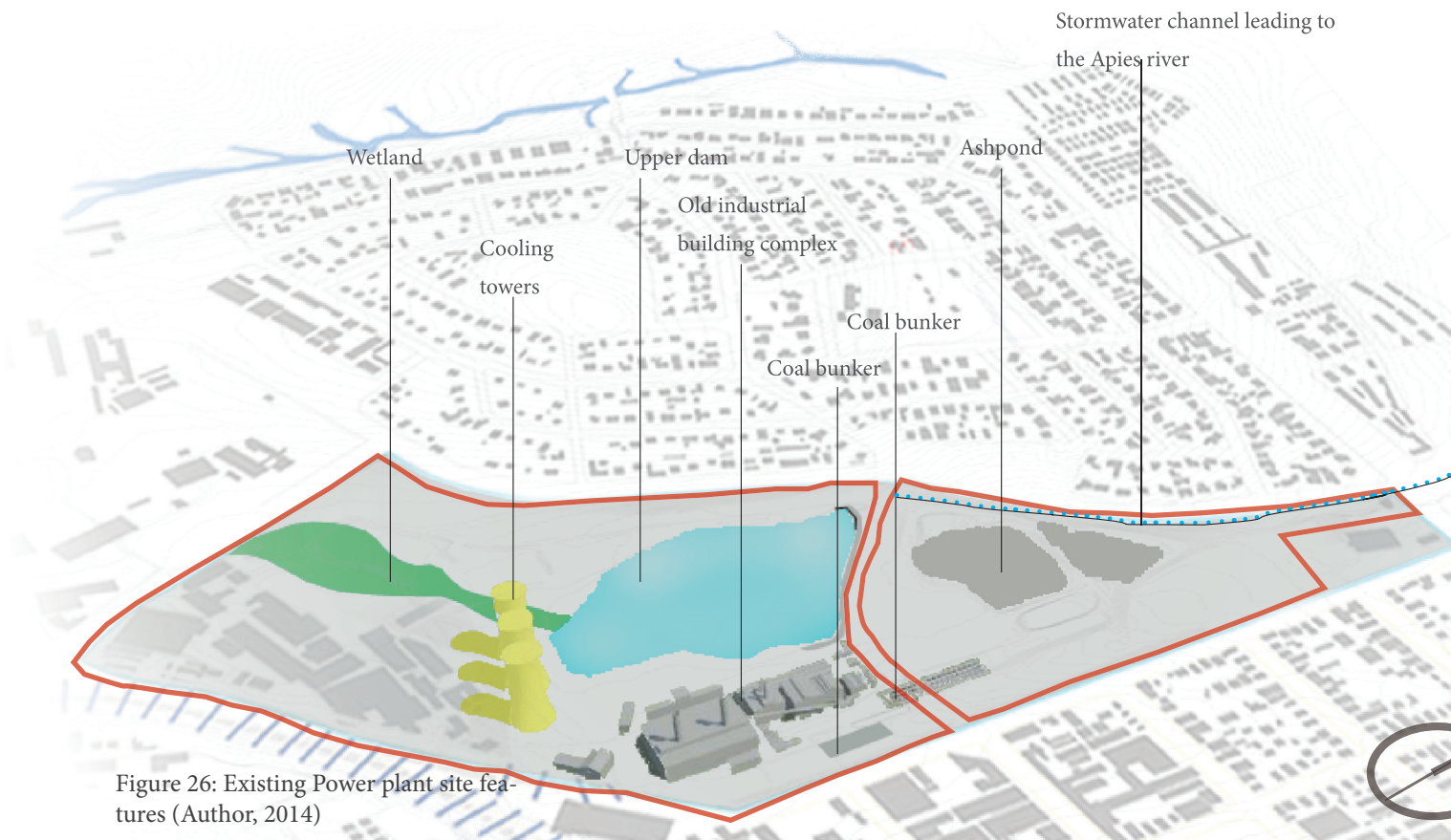

Figure 26: Existing Power plant site features (Author, 2014)

3.2.6 Framework proposal 2010

Description

A framework proposal by a group of master's students from the University of Pretoria identified Pretoria West Power Station as a potential site for regeneration, and a site that can counteract urban sprawl. The aim is not to discard the 2010 objectives but to develop key concepts of the proposal. The individual interventions on the site are seen as built form for the purposes of this dissertation. The framework proposal, however, is adjusted in this chapter:

The dissertations that were accessed include:

- Pauw, I. 2010. [re]-find: Pretoria West Power Station: reproducing the furniture industry through adaptive reuse. Furnitureworkshop.
- Joubert, D. 2010. [ex]change: an architecture for experience, a train station and intermodal freight warehouse in Pretoria West.

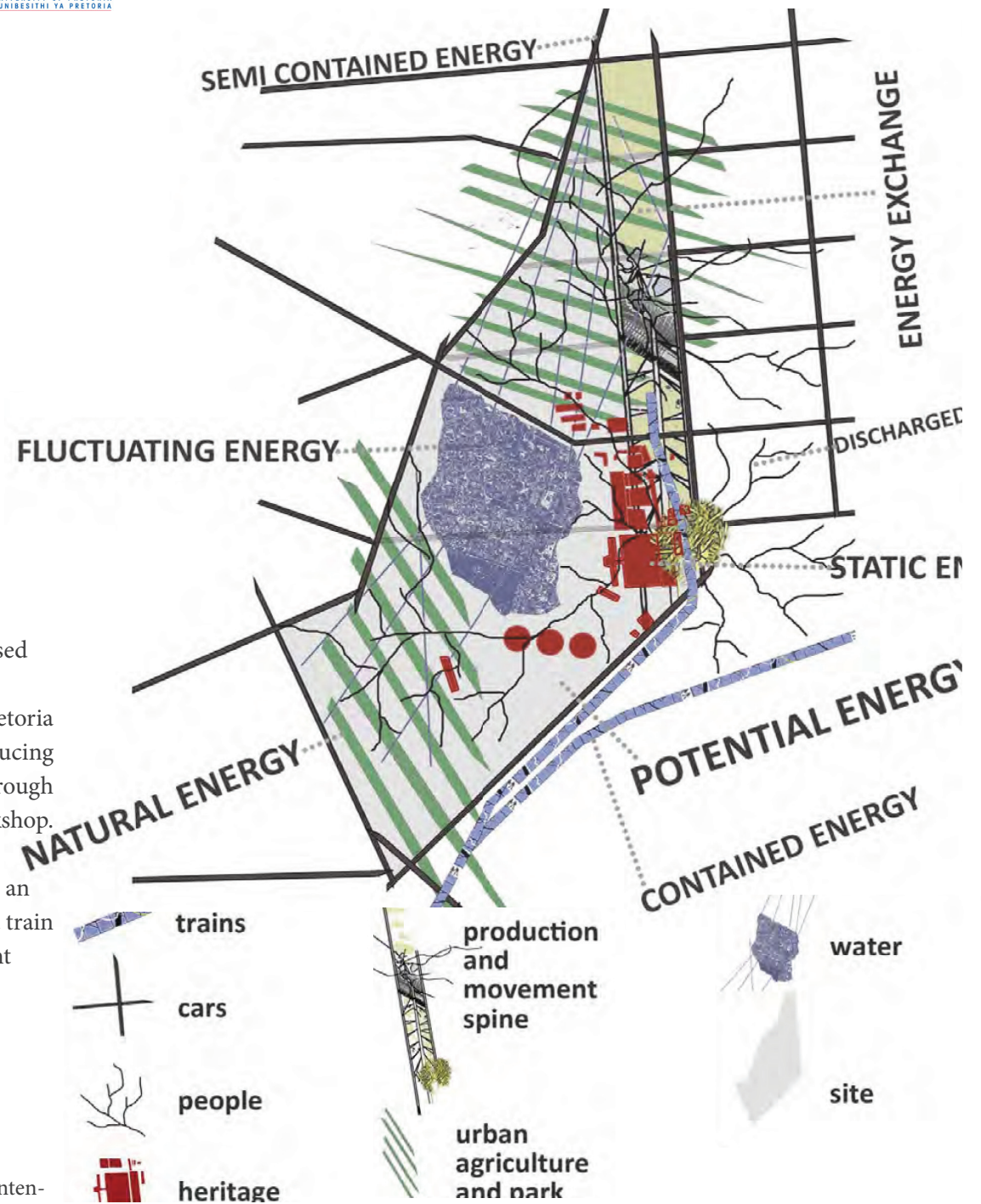

Figure 28: : Conceptual diagram of intentions for the framework by the Framework group 2010 (Smit, 2010).

- Clark, T.L. 2010. Preserve. Integrate Intervene: Progression at the Pretoria West Power Plant. (The intervention is a mix use building with the programme of residential, commercial and artist's workshops).
- van Biljon, J. 2010. -[Re]-dress: a fashion event facility in Pretoria West. (Fashion workshop and events space).
- Smit, P.G. 2010. Going West: using landscape to regenerate urban form. (This dissertation is a coal bunker transformed into a walled garden).
- Davey, C. 2010. Proximity: vertical agriculture in the old Pretoria West Power Station. (Hydroponic food farm).

The dissertation of Mias Claasens, which formed part of the framework,

was only accessed to develop a complete base plan. Due to the technical nature and limited data of the building, it has been excluded from this dissertation.

Vision:

The vision that the group collectively had was to transform Pretoria West into a productive cell that acts as a sub-support system for the city (Davey, 2010). The programme for the framework was to introduce light industrial interventions to alleviate stress on current productions in the city. Collectively the vision of the framework was to visualise the precinct as a gateway and acting as an urban border that funnels people from the west towards the east (Clark, 2010). City borders provide structure and identity to the city at the same time (Kokalanova, 2013)



Figure 29: Framework proposal by the 2010 framework group (Smit, 2010)

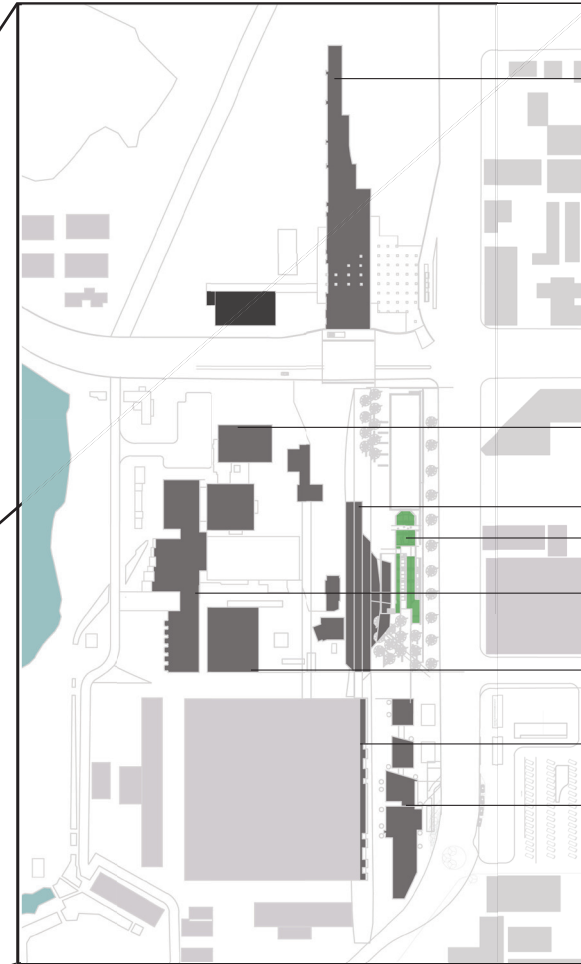

Hydroponic food farm

Clothing manufacturer

Train station

Entrance square

Mix use building- Residential, workshops and restaurant

Furniture manufacturer

Intermodal freight storage warehouse
Biodiesel plant

Figure 30: Base map constructed from the individual interventions from the framework group 2010 (Author, 2014)

3.3 Critique of 2010 Proposal

3.3.1 Urban border

3.3.1.1 Negative urban border:

Borders are placed to secure space. A border can have a dual function of connection and separation (Kokalanova, 2013). The Pretoria West Power Station proposal acts as a border between two land uses identified on either side. In this case, the urban border created by the framework group has solely focused its energy towards the east, as illustrated in figure 31. The low-income residential area towards the west is only acknowledged in terms of people moving through the gateway to access the so-called centre of society on the eastern side. The border in this case has a negative connotation, being linked to sociological terms like marginalisation and exclusion (Kokalanova, 2013).

3.3.1.2 Reversing the border

The negative connotation of the border can be modified through two models of integration. Homogeneity and diversity can alter the segregated effect that a border has.

a. Homogeneity

Homogeneity means that the two different identities or structures on either side of the border have to adapt into one melting pot to become a new identity (Kokalanova, 2013). The border should belong to both identities simultaneously, as indicated in figure 32, where green suggests the border that is now occupied by a combination of yellow and blue identities on either side.

b. Diversity

The precedent of the border between the “Fakulteta” segregated ethnic Roma settlement and the rest of Sofia is used as a comparison to the segregated areas of Proclamation Hill, West Park and Kwaggasrand from the centre of the Tshwane CBD. The socio-cultural groups of people in both areas are heterogeneous. There exists diversity in cultures according to the census data of 2011. The urban form has an undefined language. It is not to be confused with a spontaneous settlement or a slum. It is not excluded from the city but there is a border between this community and the rest of Tshwane.

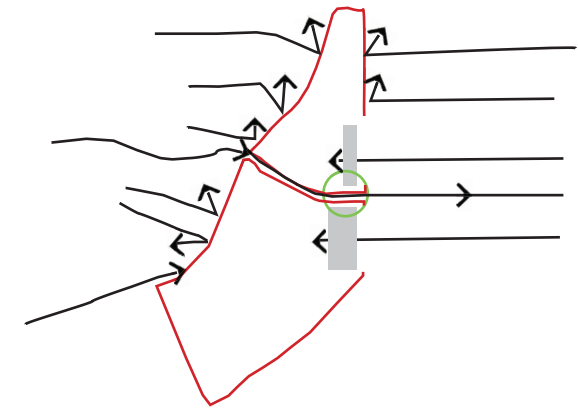

Figure 31: The boundary acting as a separation due to energies focused on the east. The material differences between east and west also become part of the boundary (Author, 2014)

A model of diversity was used to diminish the border of created by the Pretoria west power station. This model is based on the co-existence of different identities or structures without any adaptation, as seen in figure 33. The two identities that are merging is a residential and a light industrial / productive identity. A new public identity is formed.

3.3.1.3 Urban transformation

The transformation needs to be both a physical and a mental one:

a. Material border

The built structure of the site is completely different to its surroundings (Kokalanova, 2013). The border area (Pretoria West Power Station) has its own character and structure. Figure 25 indicates the different land uses that surround the power station. The power station has a different identity to its surroundings.

b. Mental border

Settlements situated west of the core of cities have an historical association with discrimination and are generally described in a derogatory way.

The border has to be acknowledged as a space of its own and has the potential to become a transitional space between the two areas. Dual function is crucial as a separating and connecting entity. The border can act as a symbol of interaction and encountering (Kokalanova, 2013). If borders are understood as transitional spaces, planning will not be focussed on the product of built urban form but on the processes involved.

3.3.2 Isolated productive entities

The individual productions on the site exist in isolation. There are no synergies between processes.

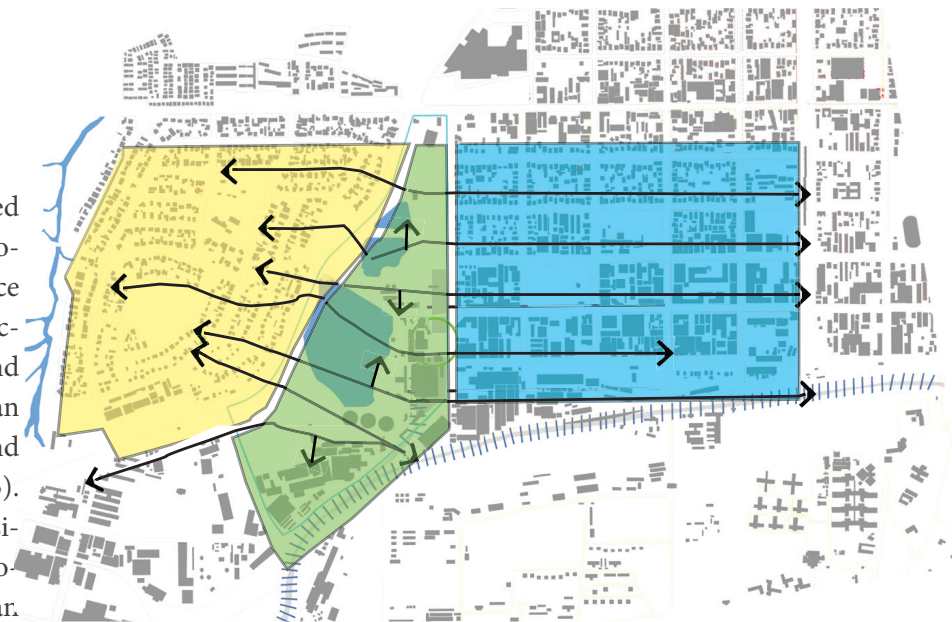

Figure 32: Identities on either side of the boundary is combined within the boundary (Author, 2014).

The resources are mostly sourced via rail transport from other regions in the country. The vast landscape available is labelled by the framework group as urban agriculture, but the basic requirements for such a productive landscape are un-resolved

b. Productive cell

The program is generated through identifying critical resources within the 2010 proposed system. The objective of the 2010 framework proposal is to become a sub support system for the city, but raw products are still imported from various sources without taking the resources of the site into account. The production types that this dissertation is focused on, is a response to a myriad of resource demands for the 2010 “productive cell”.

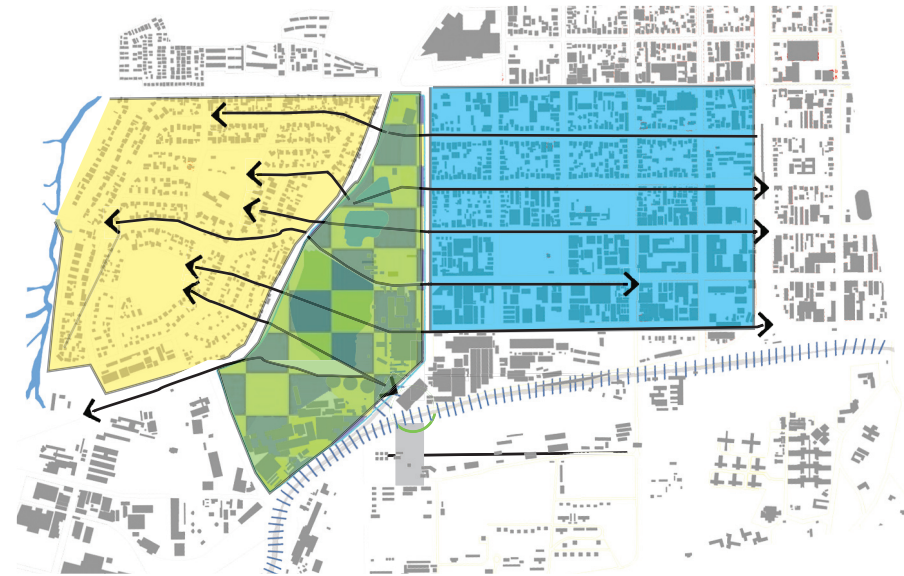

Figure 33: : Identities on either side of the boundary are combined within the boundary (Author, 2014)

3.4 Urban objective

The urban objective is a response to the urban investigation and critique.

3.4.1 Programmatically

The urban objective is to develop a program that responds to the critical need for resources on the site, as seen in figure 36. The ideal is that the landscape will be the synergy between the proposed light industrial schemes. The urban framework has to reflect the overall intention of subjecting the user to processes involved on site.

3.4.2 Combating the urban boundary

The two different identities on either side of the boundary can adapt to form one identity on the site. One identity that stretches between the

two identities will destroy the physical and subsequently the mental barrier between the east and the west. The two identities that have to merge are the social/public entity with the productive /semi industrial entity. Thus, the placement of the programs with contrasting identities has to intertwine.

3.4.3 Programme development

The programme of the proposed site is a result of the theoretical premise and the issues identified on site at a framework level. The landscape aims to respond to the raw resources required in the 2010 framework, as indicated in figure 37. The critical resources that the landscape can accommodate programmatically (as shown in figure 37-38) are discussed in the next section.



Figure 34: Urban objective (Author, 2014)

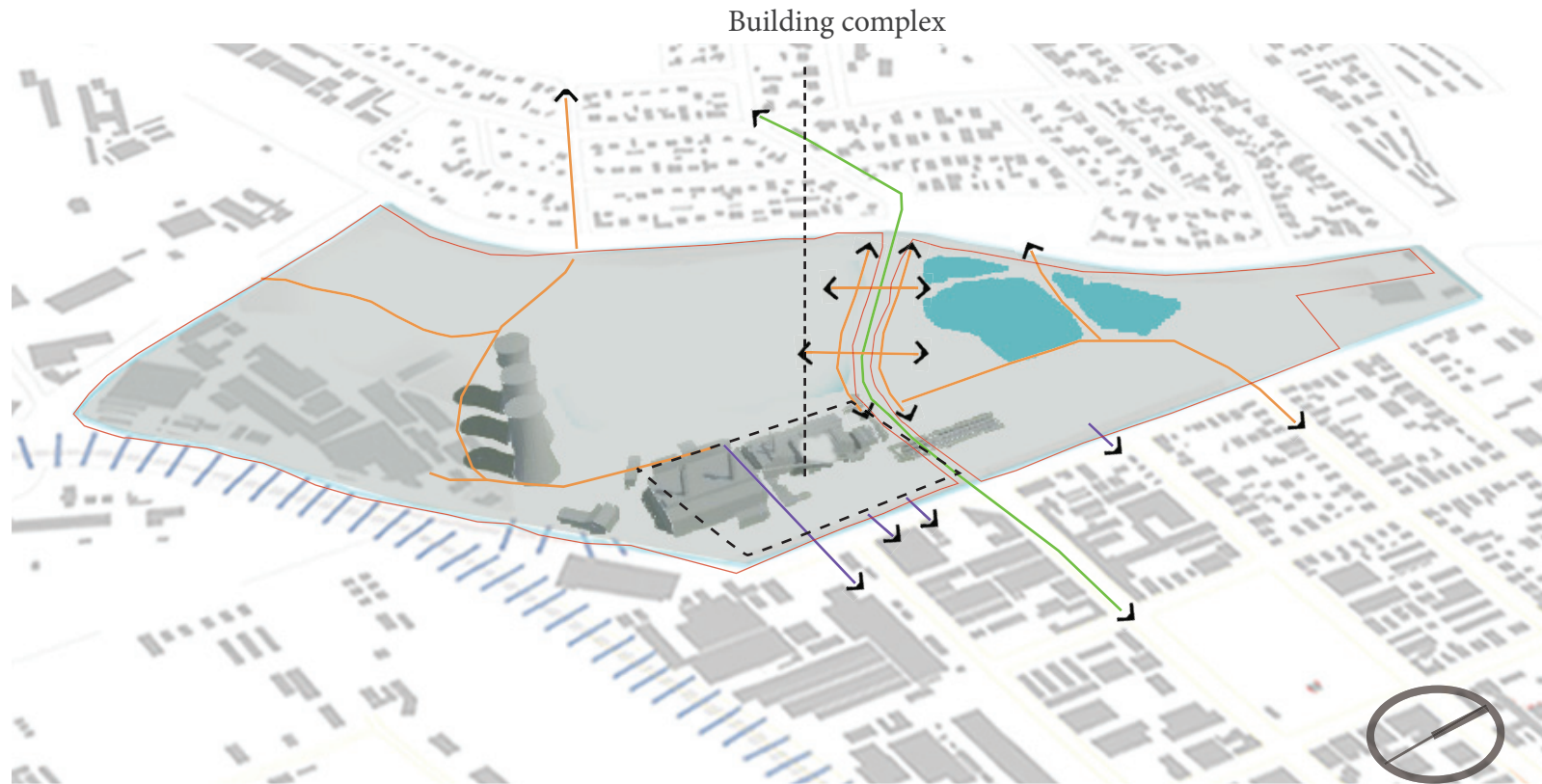

Figure 35: Movement response to the framework group (Author, 2014)

3.4.4 Programmatic requirements

The landscape intervention will supply different programmatic requirements focusing on the built complex indicated in figure 35. The existing infrastructure supplies a variety of resources for production. The design intent is to subject the user to the processing of resources. This is achieved

through locating the processes with the highest element of change in areas with high pedestrian and vehicular traffic. The proposed route / narrative has to inform the user on synergistic systems with interaction. It is therefore crucial for the systems to function as sustainably as possible, as they act as

a precedent for future productions. Figure 36 displays the network of productions existing on site. This is followed by figures 37 and 38 that introduce the productive landscape programme as a systemic network, in response to the existing productive shortfalls. A superficial analy-

sis of each of the proposed programs will indicate the viability of these programmes on a large-scale site.

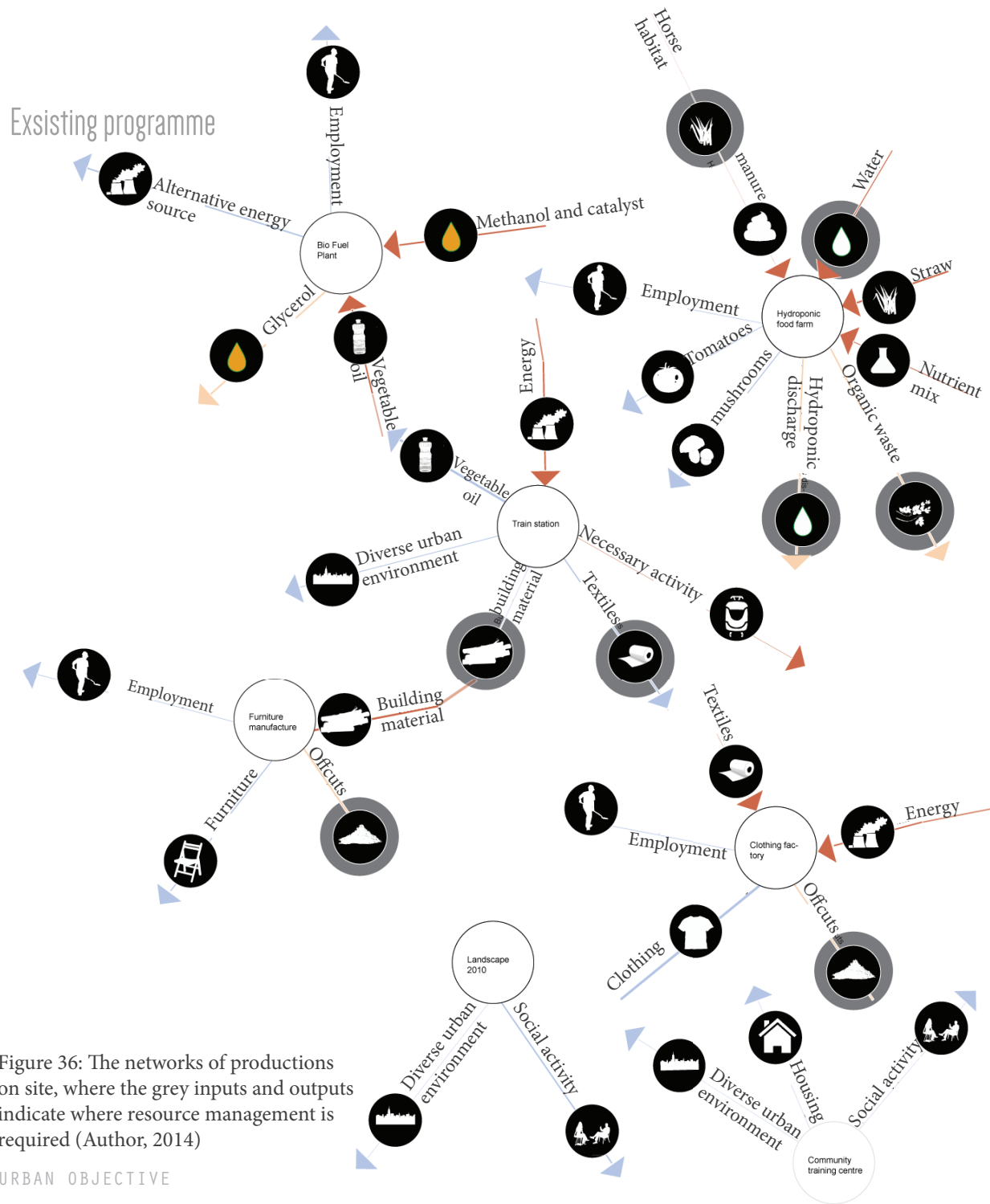

Figure 36: The networks of productions on site, where the grey inputs and outputs indicate where resource management is required (Author, 2014)

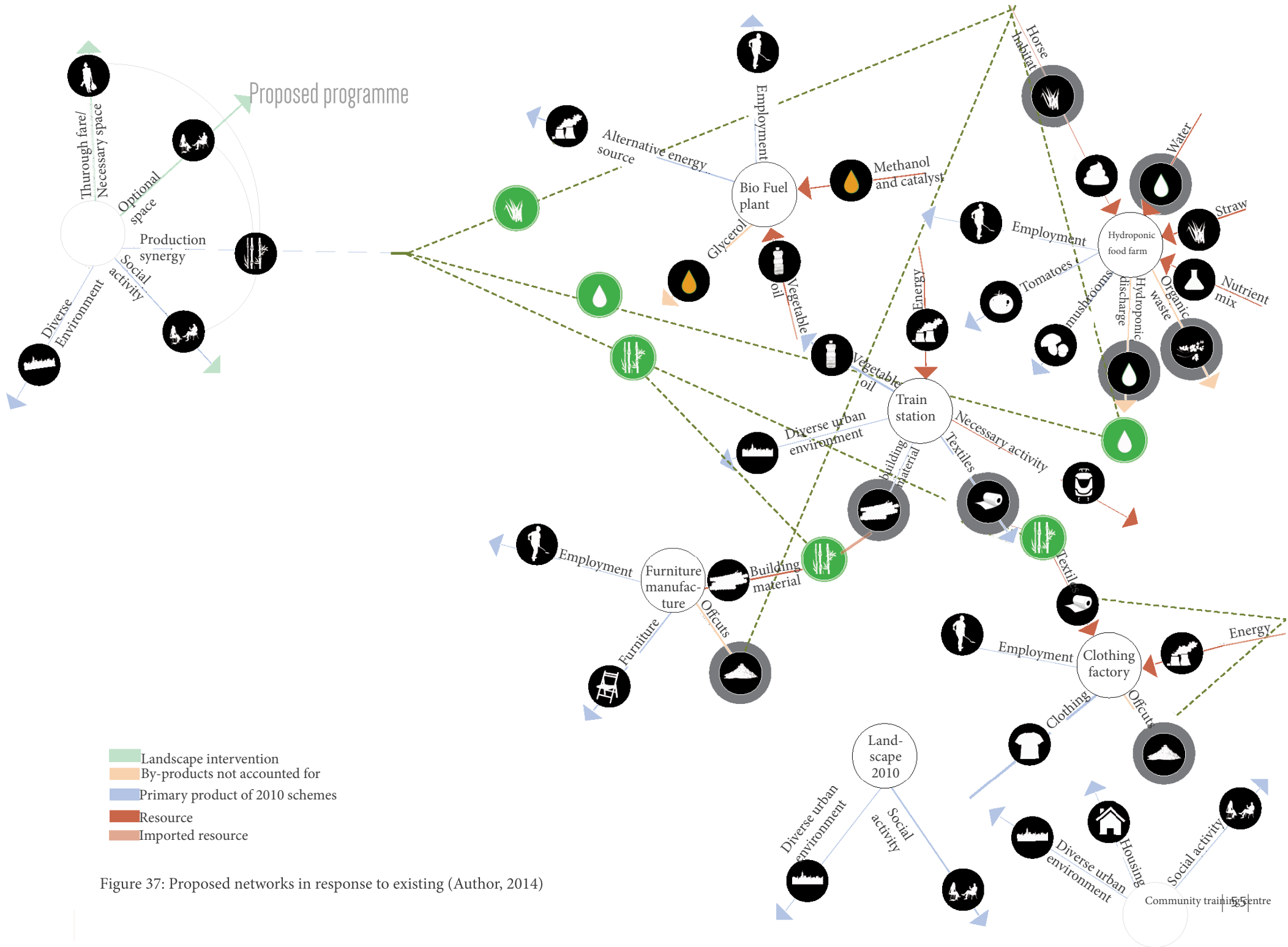

Figure 37: Proposed networks in response to existing (Author, 2014)

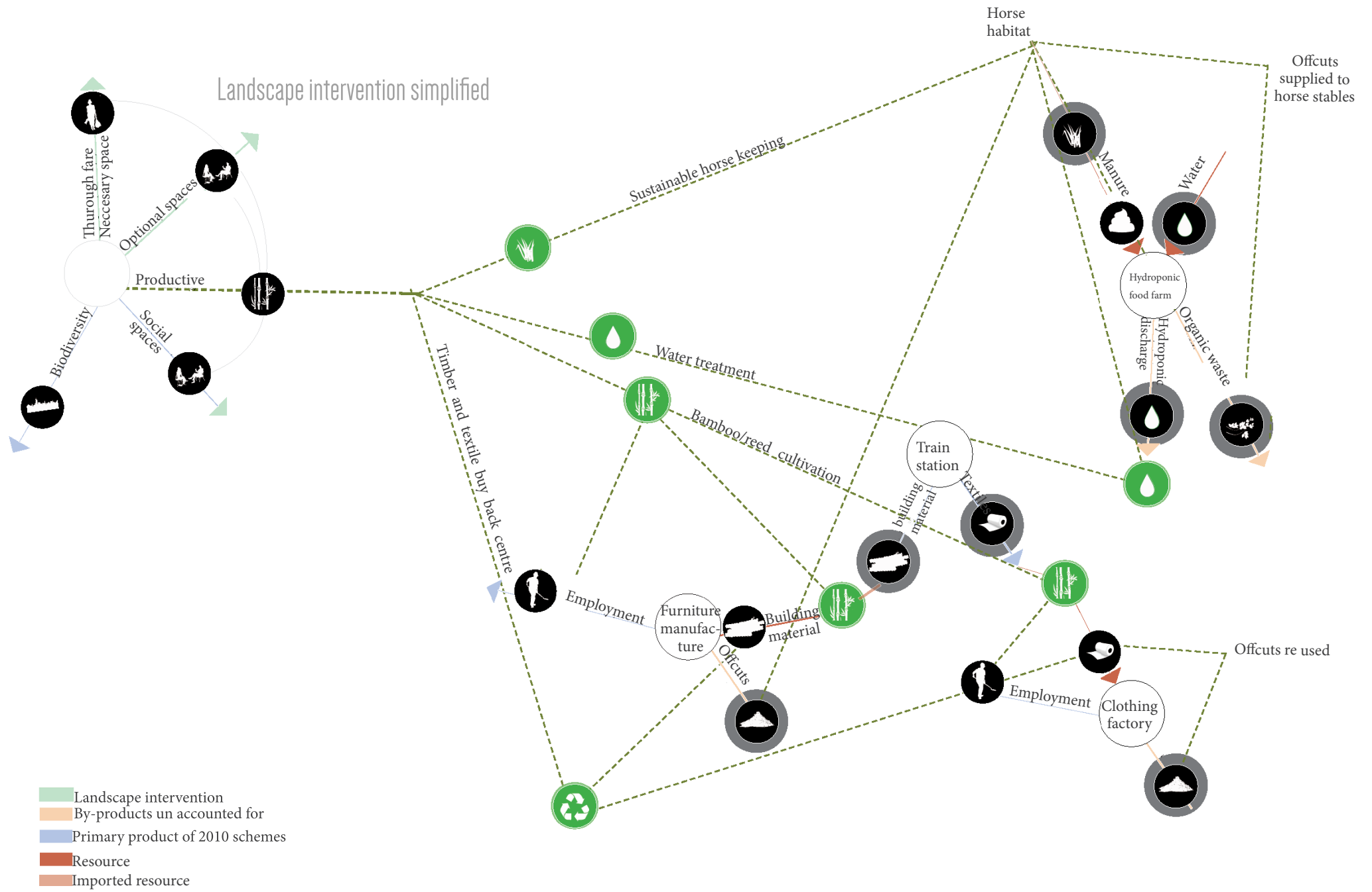

Figure 38: A summation of the proposed programme (Author, 2014)
56 URBAN OBJECTIVE

3.4.5 Programmatic proposals on the framework scale

The landscape intervention responds to the existing productive entities on site that are all located in the square indicated in the figure 39. It is proposed in this dissertation to introduce:

1. Bamboo as a landscape element (the economic viability study for the growth of bamboo is presented in appendix 9. 2).
2. A water treatment and management facility.
3. A timber and textile buyback centre.
4. A sustainable equine environment.

The productive entities introduced above are investigated separately to determine whether a site design can accommodate all of the requirements

of each individual programme. The investigation's aim is to determine whether the site has the capacity to accommodate an integrated productive cell. the site has the capacity to accommodate an integrated productive cell.

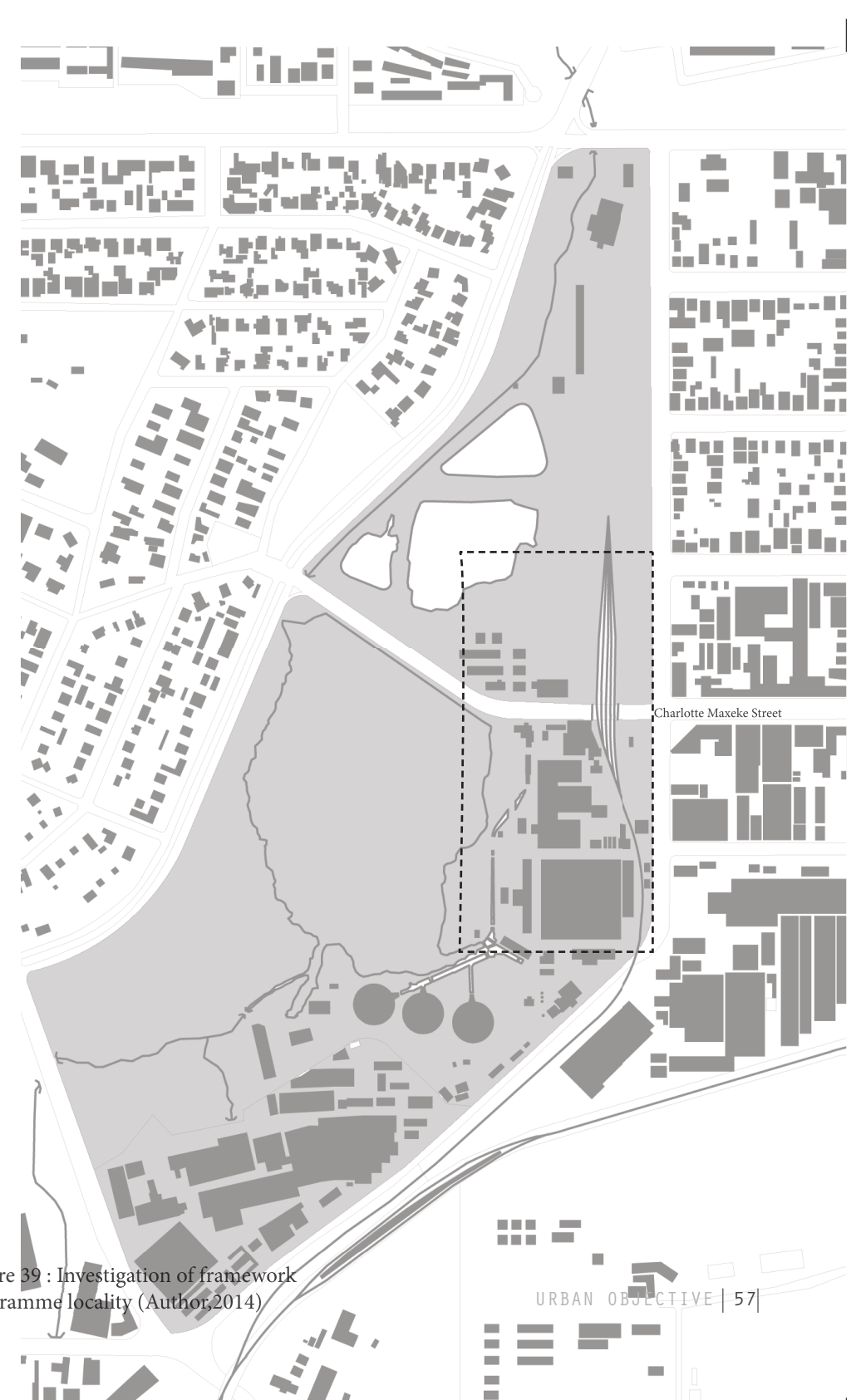

Figure 39 : Investigation of framework programme locality (Author,2014)

Bamboo production process

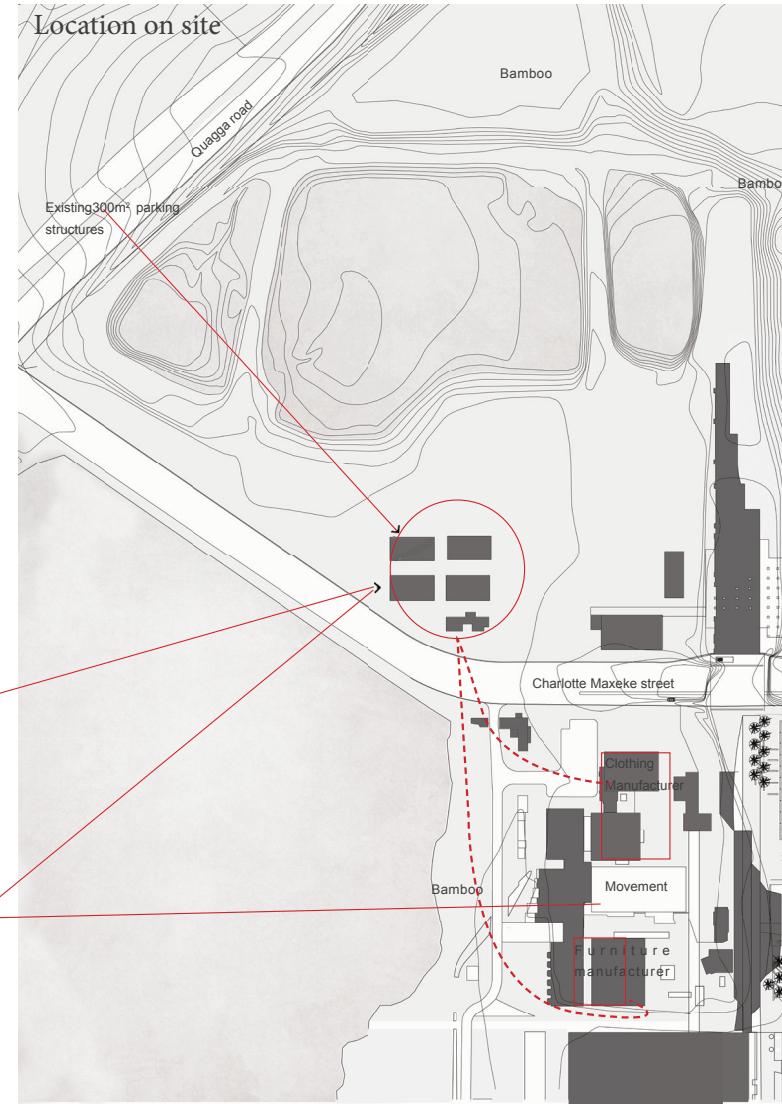
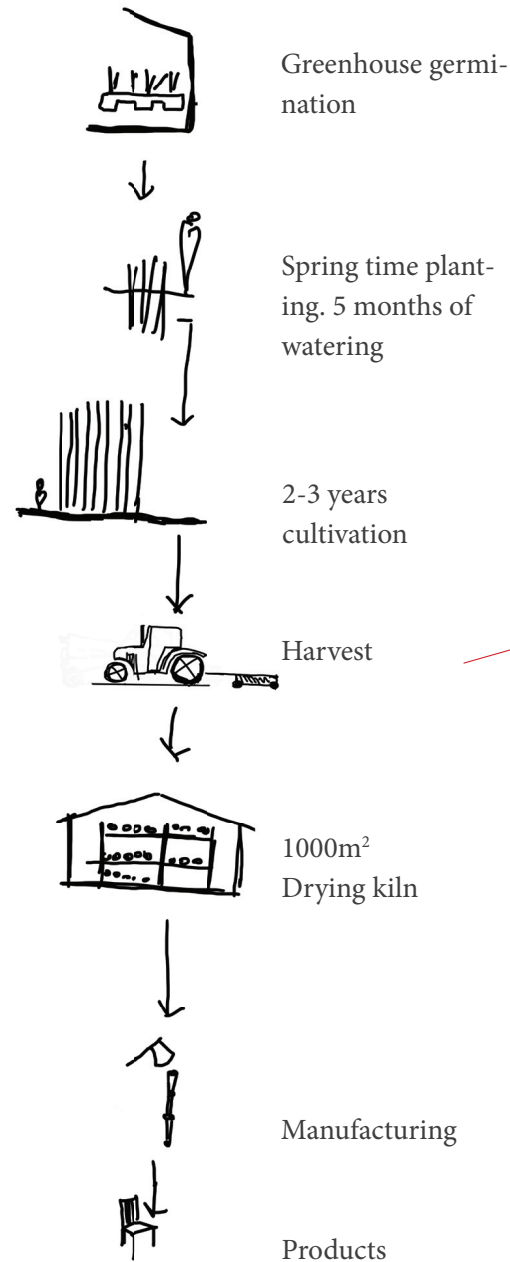

Figure 40: Requirements for bamboo production (Author, 2014)

3.4.5.1 Bamboo production

Possible species:

The viability of producing bamboo as a crop on the site is determined by assessing the conditions required for a minimum crop harvest. Therefore, species were chosen for functional reasons. Species with clumping, rather than with “running” or straggling root systems, were chosen, so as to have minimum damage to the urban environment in which it is planted. An indigenous species, *Thamnocla-manustesselatus* (Berg Bamboes) was chosen, in addition to the naturalised species, *Bambusa balcoa* which has a fast growth rate (Sampson, University of Pretoria Curator, 2014).

Phases of production:

There is a set of requirements for each phase of production. The first phase is cultivation. Micro propagation by means of tissue culture in a greenhouse is required. (Brightfields Natural Trading Company, 2009).

The second phase is supplying the correct habitat for the species. Bamboo grows in drained soils in temperate environments.

The main specie used reaches 21 – 25m in length. In addition to the habitat requirements, the young culms need to be staked within the first 5 months, as this is the time in which the culm reaches its mature length. Within the first 5 months regular watering is crucial. The remainder of the 3-year cycle requires less watering, until the culm is ready for harvest.

The third phase of production is the harvest. The harvest time depends on the application or use of the bamboo. The harvest time is 2 years if the application of the bamboo is screen- making. Bamboo with a higher biomass is harvested 3 years from planting. Products like laminated bamboo floors and products usually made from timber plantations are produced 3 years from planting.

The base of the bamboo clumps will remain and only the mature culms are harvested. Only 30 percent of the clump is harvested. This makes it viable as a landscape element because the spatial quality is maintained.

Harvesting the culm when sap levels are at its lowest ensures a quick drying rate and higher quality timber. Photosynthesis causes higher sap levels. The culms are therefore harvested at dusk or dawn when sap levels in the culm are at their lowest. In addition, sap levels are at their lowest at the end of the dry season (Dunkelberg, 2002).

Phase four is the manufacturing of the harvested materials. Harvesting requires transportation facilities such as a tractor. The landscape needs to accommodate the storage thereof. A covered structure 1000m² with good ventilation is required for the drying and processing of the bamboo. A re-used steel warehouse has the potential to serve this purpose.

Machinery is required for cutting, splitting, planing and board pressing. The bamboo production will need 10 people at the beginning and 15 people for processing (Brightfields Natural Trading Company, 2009).

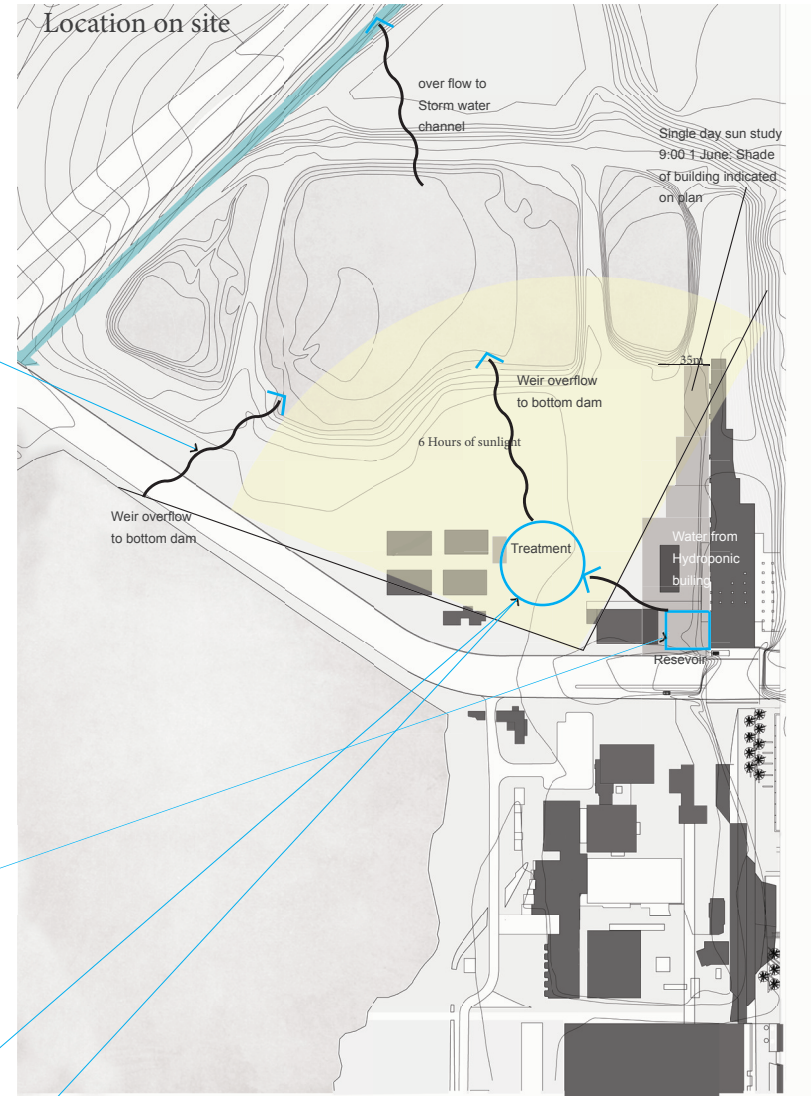
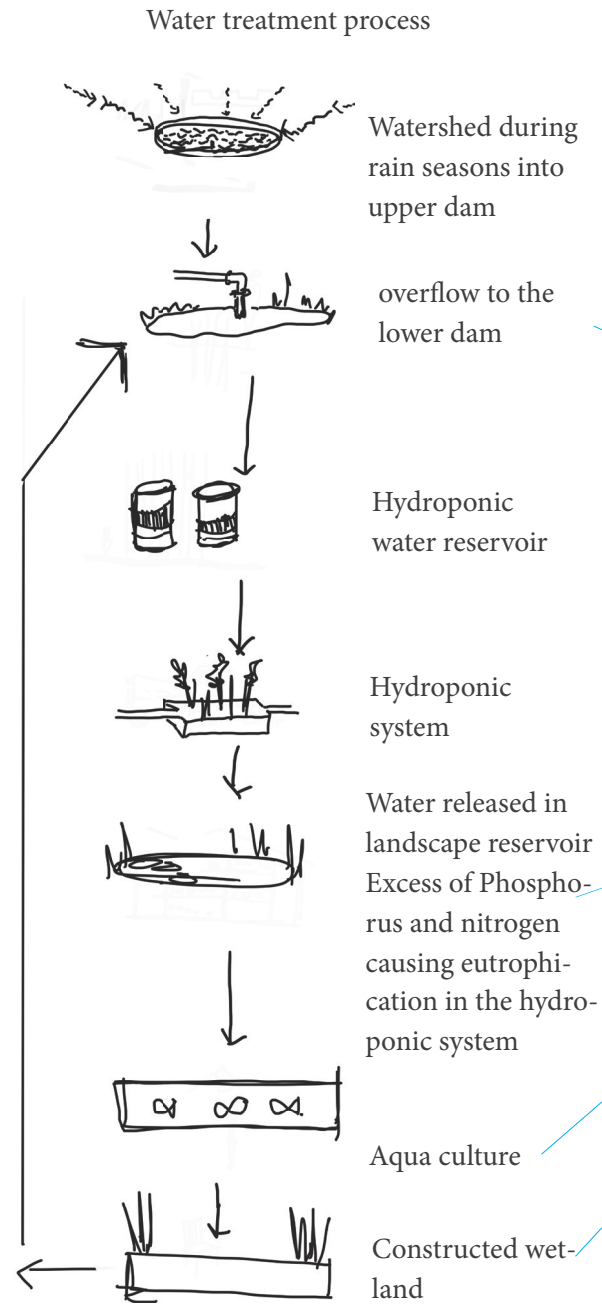

Figure 41: Water treatment requirements (Author, 2014).

3.4.5.2 Water management

Water treatment:

322,000 litres of water, containing excess nitrogen and phosphorus, exits the hydroponic food farm on a weekly basis. This water is released from the farm with high velocity into a landscape reservoir. The landscape reservoir releases the water at a slow rate into a treatment facility. The water is treated by a reed bed, followed by a water body containing algae-eating fish species (tilapia) that further acts as treatment.

Location of the treatment:

For treatment purposes, the body of water needs to be situated in an area that will have a minimum of 6 hours of sunlight per day (Gruyer, et al., 2013). The hydroponic food farm is situated on the eastern border of the site. 3D modelling software (Autodesk Revit) indicates that the 6 – 7-storey building prohibits morning sun for 40m west of the building in the winter solstice.

Water harvesting:

Water from the site is diverted into respective dams. Storm water management of the focus area of the scheme will be investigated on a master plan and detailed scale.

3.4.5.3 Horse habitat

The landscape can contribute to the resources required to maintain horses in the following way:

1. To support the horse's dietary needs.
2. Supply the required water demand.
3. Supply a healthy-sized paddock.
4. The site can supply pastures for forage. Grazing pastures need fertilisation (grass should never be less than 10 cm high for photosynthesis to occur). A paddock placed adjacent to the stables would be far from the irrigation ditches or waterlogged areas. The minimum size of the paddock is 25 m² per horse, thus 12 stables on site equals 300 m² Paddocks with trees around the edges ensure shade during the day, especially from the west. A horse needs between 20 – 40 litres of water per day. This equals to a monthly demand of 14 m³ (the water budget calculations are available in appendix 9.1)

Horse requirements

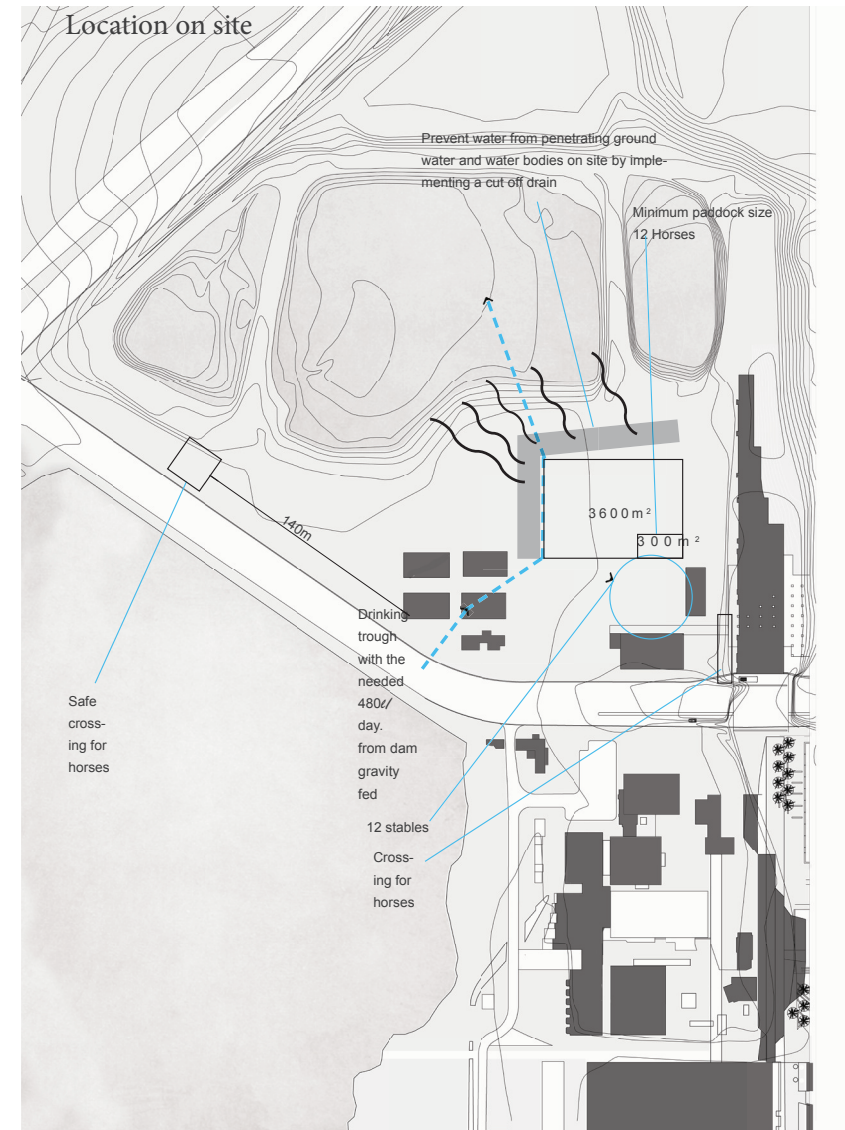
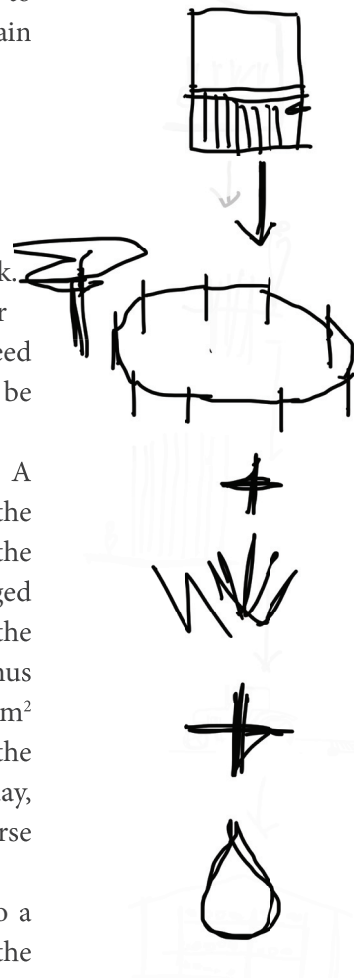

Figure 42: Horse habitat requirements (Author, 2014)

3.4.4.4 Timber and textile buy-back centre

A timber and textile buy-back centre is proposed to minimise imports for the clothing factory and furniture manufacturer. The landscape has to provide the buy-back centre with a defined space where vehicles can drop materials off. The landscape should gain access to a building where storage and sorting can take place and where secure transactions for goods can occur.

The landscape has to supply an appropriate route to transfer materials between the clothing factory and the furniture manufacturer.

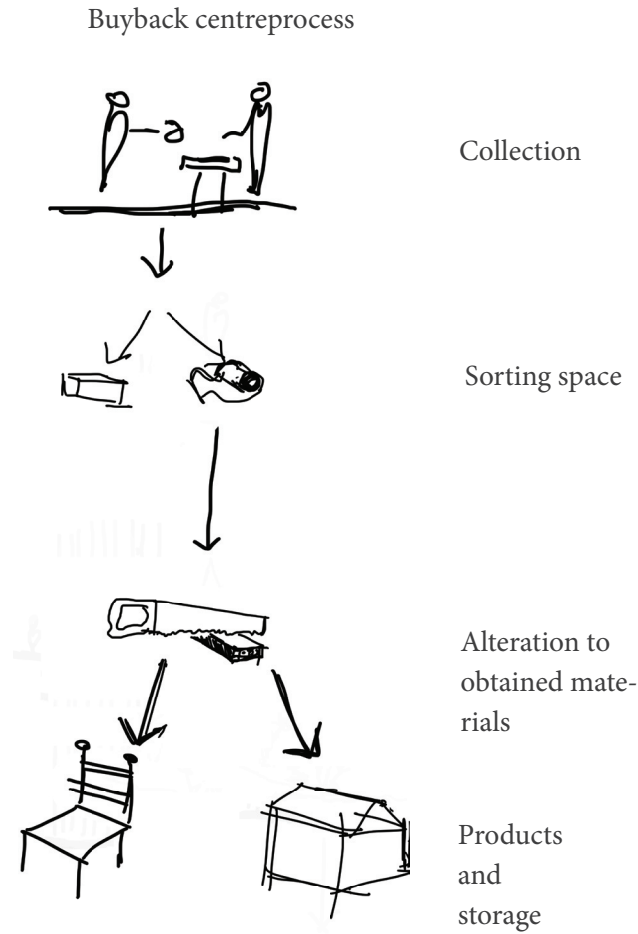

Figure 43: Timber and textile buy-back centre (Author, 2014)

3.4.4.5 Food production

The design of the hydroponic food farm building allows it to expand in a northward or eastward direction, depending on demand. The land use towards the north of the site around the building is thus zoned for agricultural use. The proposal is for the zoned area to become a controlled community food garden that is associated with the hydroponic food farm, allowing the building to expand if needed.

The requirements for the food garden are:

1. Exposure to sunlight.
2. Accessibility.
3. Water.

Water treatment process

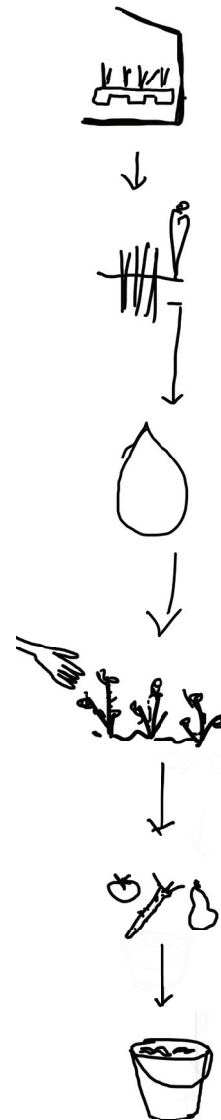

Greenhouse germination

Planting.

Year round watering

Harvest

Produce

Off cuts to horses

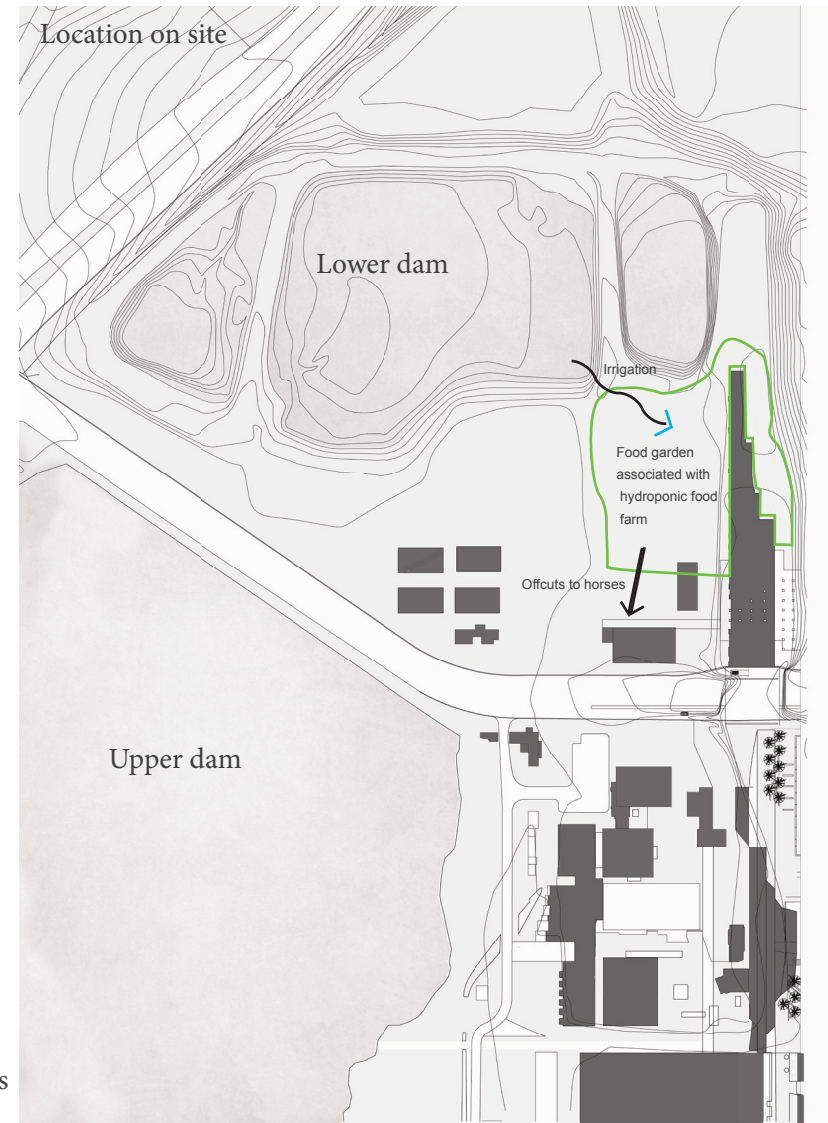

Figure 44: Food production requirements (Author, 2014)

3.4.4.6 Public spaces

Public spaces can be designed to create conditions for neighbourhoods to form (Campbell, 2014). Public spaces are categorised according to Jan Gehl's classification of activities in his book, "Life between buildings", 2006.

1. Necessary spaces

Smart, resilient cities are self-organised in terms of necessary and social spaces. Their complexity does not only focus on programmatic requirements. Necessary spaces are obligations and necessary activities. An example is going to school or grocery shopping. The influence of physical environment on these activities is minimal. There is no choice for these activities (Gehl, 2006). An example of necessary space in this context is:

- a. Thoroughfare connecting the transport interchange node with the residential area.
- b. The existing market.
- c. All internal circulation routes

2. Optional spaces

If time and place make it possible, then optional activities are pursued. Examples of optional activities are taking the dogs for a walk and sun-

bathing. These types of activities are only pursued in favourable weather conditions. When outdoor areas are of poor quality, only necessary activities occur. When outdoor areas are of high quality, necessary activities take place more or less at the same frequency but take longer because the physical conditions are better (Gehl, 2006).

An example of this within this context is:

- a. The route to the community centre.
- b. The horse trail for patrol and recreation.
- c. All activities associated with water and the events park
- d. The picnic areas
- e. The Walking trail.

2. Social spaces

Social spaces only occur with the presence of optional and necessary spaces. Social activities are conversations, communal activities, children at play etc. These activities are spontaneous, and only occur when the other activities are active.

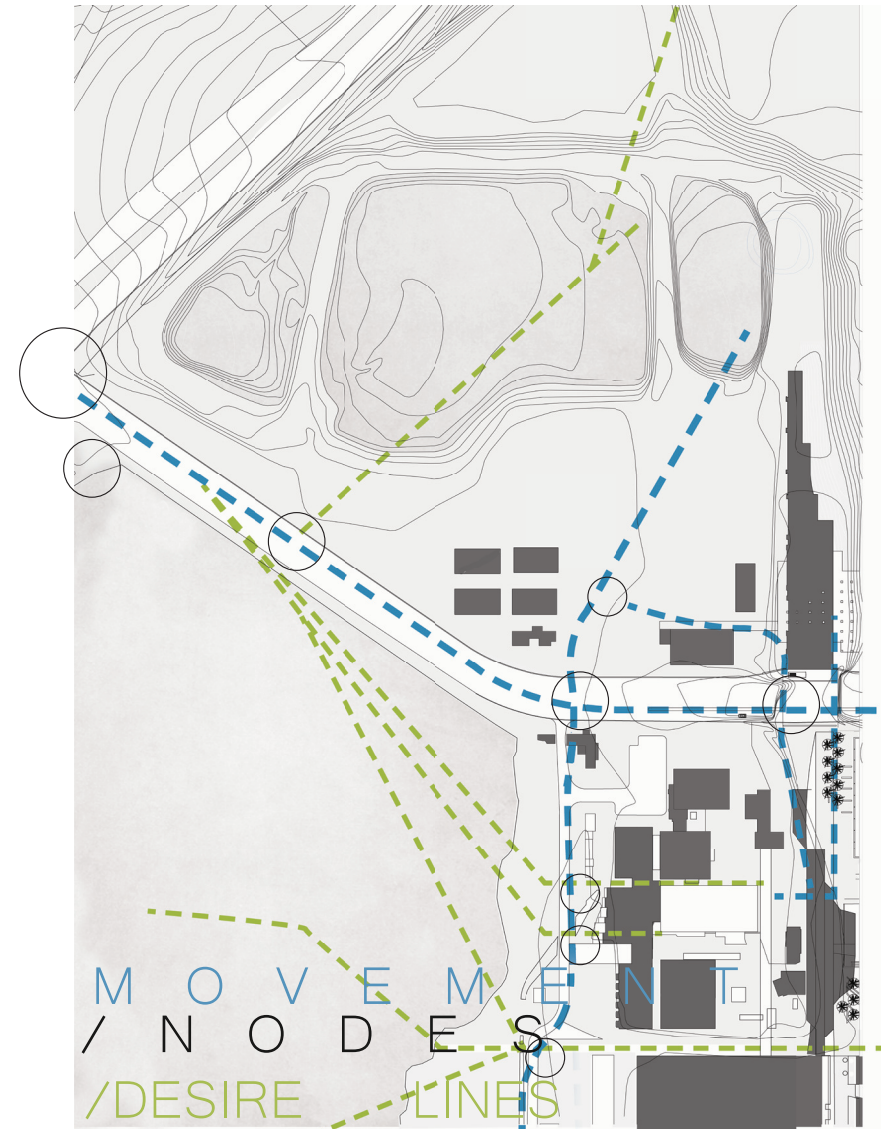

Figure 45: Movement diagram on site (Author, 2014)

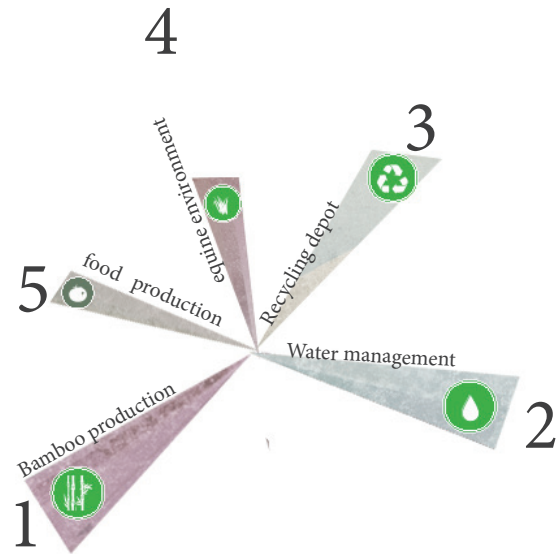

Figure 46: Hierarchy of the productive programme (Author, 2014)

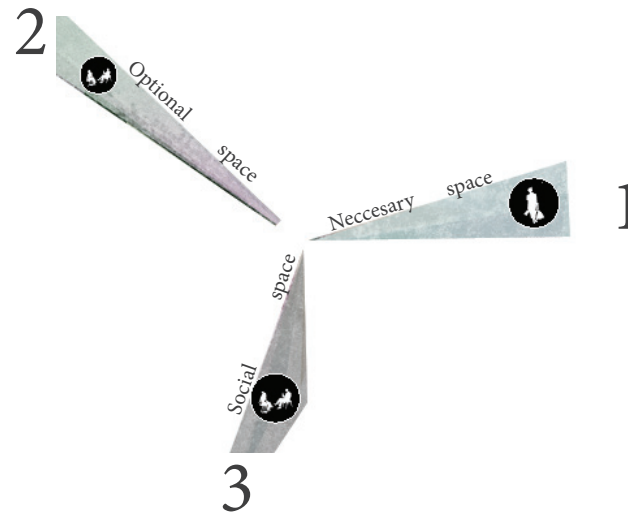

Figure 47: Hierarchy of the public spaces (Author 2014)

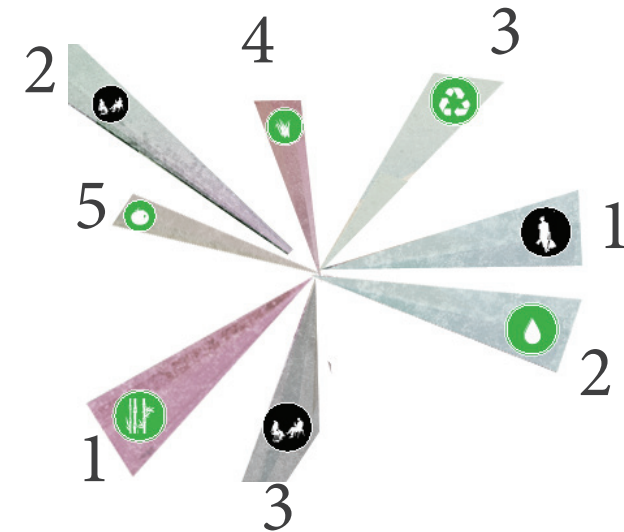

Figure 48: Hierarchy of the combined categories programme (Author, 2014)

The physical framework does not have a direct influence on the quality or the content and intensity of social interaction but can affect the possibilities of contact in the public space where people walk, sit and talk (Gehl 2006). Some examples here are

- a. A Playscape or conditions for children's play
- b. picnic spaces
- c. meeting areas

3.4.6 Programmatic hierarchy

A hierarchy is given to productive and public spaces to determine which element would form the focus for detail resolution.

3.4.6.1 Production hierarchy

The hierarchy is based on the carrying capacity of the land. The different productions on site are placed on a list of importance according to the production that will have the largest increase in resource.

3.4.6.2 Public space hierarchy

The landscape needs to be communicated in a non-consumerist way.

The hierarchy is based on how the different public spaces communicate the productions. The route and spaces most travelled (high traffic routes or necessary routes, according to Gehl) thus have hierarchy and are the most important to focus on. The classifications of spaces for human use and for production use are combined to have an integrated response.

3.4.7 Site Opportunities

1. Water pumped from the Daspoort wastewater treatment facility is expected to cease the moment construction on site begins. The dam is full due to the current continuous water supply from the Daspoort wastewater facility. When rainwater harvesting commences the site will have existing water as a starting point.
2. Water discharged from the hydroponic food farm is used in future systems. A contemporary way to treat hydroponic effluent is through constructed wetlands (Gruyer, et al., 2013). An opportunity is to use the *Typha capensis* reed to treat water and simultaneously act as an additional crop, Algae eating fish species dually act as a treatment mechanism and a species which is farmed commercially is the Mozambique Tilapia.
3. The site has 25 ha of plantable area. The crops of choice are species that grow easily in a temperate environment with minimal frost. The size of the framework site

allows for a variety of production and public spaces.

4. The production entities mentioned above are seen as an opportunity to create synergy on the site, as seen in figure 37-38.
5. Production can be combined with public walkways to educate the user about the productive systems.
6. Apart from the user being spatially embedded and part of the site, users can contribute to the systems by supplying timber or textiles to the buy-back centre or participating in the community gardens.
7. The drastic growth of the bamboo can have a large impact on the user, by both acting as a spatial definition and as a productive system.



3.4.8 Site Constraints

1. The western side of the site borders a mobility spine according to the TSDf (2012). A mobility spine does not allow direct access to adjoining land uses, no on- street parking is allowed and pedestrian movement is restricted. Land uses adjacent to the mobility spine are zoned as nodal development sites with mixed land uses
2. Charlotte Maxeke Street (figure 51) divides the framework site north and south. It is classified as an activity spine. The sharp corner and the level difference make it a dangerous crossing point. Movement across this street is necessary however, and the landscape has to respond to this movement as indicated in figure 50.
3. The public square is lower than the water level. Constant seepage occurs through the retaining wall as indicated in figure 50 and 52.
4. The logistics of supplying water to the horse paddock is a constraint. The water will have to be recycled from the treatment facility.



FIGURE 52: VIEW OF SEEPAGE THROUGH WALL (AUTHOR, 2014)

3.5 Precedent studies

Precedent studies aid the design process to achieve the intentions drawn from the hypothesis. The following scheme intentions communicate objectives for the urban framework.

Scheme intentions on an urban framework level:

1. To establish quality public open spaces for public regeneration. This holds specific reference to providing public open space for the diverse communities of Pretoria West and responding to the current segregated affect that the site has.
2. The urban framework must be designed skilfully to integrate the community into the surrounding urban context.
3. The productive systems must be designed to be an integral part of the urban setting.

3.5.1 Public open space and public access by regeneration

Project details

Twisted Valley by Grupo Aranea
Vinalopó / Elche / Alicante/ España
115,000 m²

Objectives:

- To connect users to a lost landscape.
- To assist in pedestrian movements that are necessary though the site, to points of attraction.
- To provide public open space to a high-density urban area.

The system of walkways gives a voice to the river.

Translation into scheme:

Twisted Valley displays a range of pathways with different characteristics. The network of trails “folds, bends, stretches, tightens, disperses, curves and twists” (Landezine / Landscape Architecture Works, 2014).

This system of pathways is based on how effectively the productions will be communicated to the user.

The concept of the path system being an entity on its own calls for continuity. This is achieved through using the same materials for the bridge and the pathway. The second method that the designers used to create the idea that the pathway is an entity on its own is how the pathway system does not adhere to the “orthogonality” of the city (Landezine / Landscape Architecture Works, 2014).



Figure 54: Figure ground of city with Twisted Valley proposed intervention (Landezine / Landscape Architecture Works, 2014)

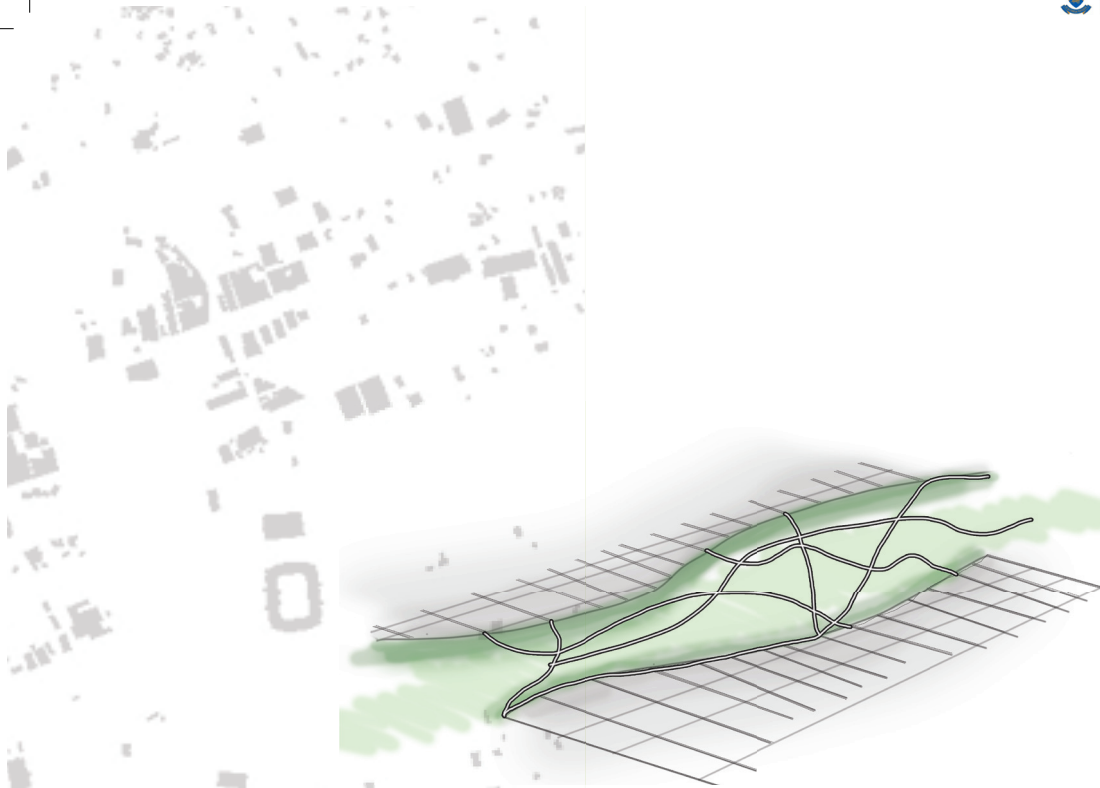

Figure 55: Route seen as an entity of its own connecting the two sides of the river (Author, 2014)



Figure 59: Urban intention / framework master plan indicating the extent of the urban spine that the river can create (Landezine/ Landscape Architecture Works, 2014)



Figure 56: Photograph of walkways up the steep slopes around the Vinalopo River (Landezine / landscape architecture works, 2014)



Figure 57: Photograph of walkways crossing the channelled Vinalopo River (Landezine / Landscape Architecture Works, 2014)



Figure 58: An indication of the route's multifunctional use in a lower income community (Landezine / Landscape Architecture Works, 2014)

3.5.2. Community relationships

Project details

Cantinho do Céu Complex Urbanization by Boldarini Arquitetura e Urbanismo

Grajaú district, São Paulo, Brazil, 2008

150 hectares

Objectives:

- The main objective is to integrate precarious settlements into the city.

- To provide the settlements with the necessary infrastructure for individuals to develop within a society and for communities to form.
- To create mobility within the settlement and integrate this mobility with the city as seen in figure 64.
- To provide a public collective space for the settlements and the community.

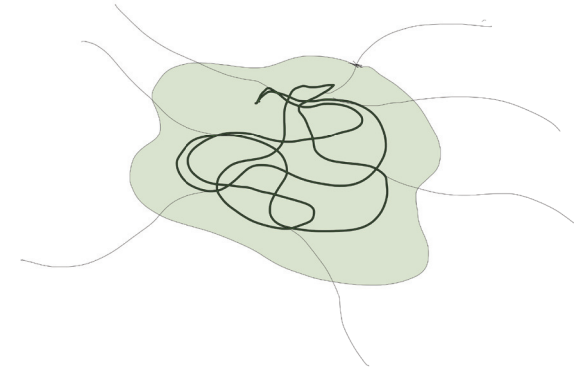

Figure 63: Central network connects with surrounding fabric (Author, 2014)

Translation into scheme

“This valuation of public space, understood here as the set of elements capable of supporting the widest range of collective daily manifestations – streets, alleys, squares, parks – tries to rescue

the sense of belonging to the city as a basic condition for the development of future generations” (Landezine / Landscape Architecture Works, 2014).



Figure 60: Community members enjoying the pier (Landezine / Landscape Architecture Works, 2014)



Figure 61: Pathway that connects the whole precinct, serves as a main pedestrian artery (Landezine/Landscape architecture works, 2014)



Figure 62: Community interests included in the landscape (Landezine / Landscape Architecture Works, 2014)



Figure 67: Plan of precinct indicating a ringroad which connects the precinct to the rest of the city (Landezine/Landscape architecture works, 2014)



Figure 64: Variety of activity along the water edge creates interest (Landezine/Landscape architecture works, 2014)



Figure 65: Aerial view of completed project(Landezine/Landscape architecture works, 2014)

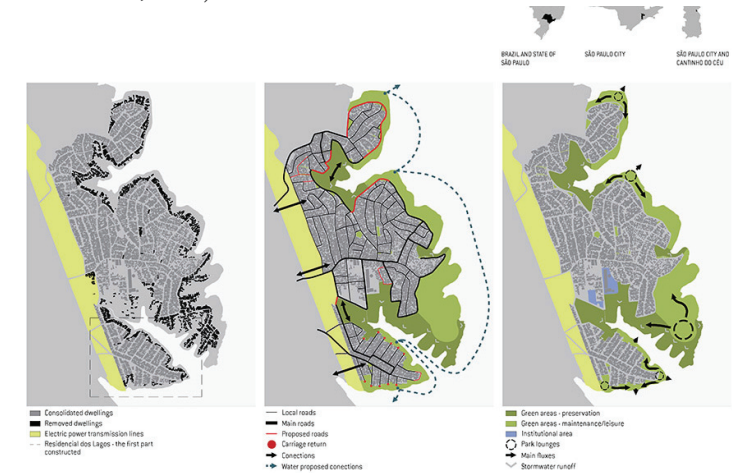

Figure 66: Conceptual drawings showing intent for dwelling, movement and green open space(Landezine/Landscape architecture works, 2014)

3.5.3 Productions integrated with urban fabric

Project details

Shenyang Architectural
University Campus
Shenyang City, Liaoning Province,
China
2004

21 hectares

Objectives:

- To combine an agricultural landscape with an urban area
- To create cultural identity through productive systems
- To respond to the urbanisation process in China (Turenscape, 2004).

Translation into scheme

Tshwane can be compared to cities in China, as it is the third largest city in the world, covering 6368 km² of Gauteng (City of Tshwane, 2010). The continuous urbanisation causes threat to valuable arable land.

The Shenyang University campus was previously a farm; therefore its productive nature is continued into a mixed-use land use where it serves both a productive and an urban role.

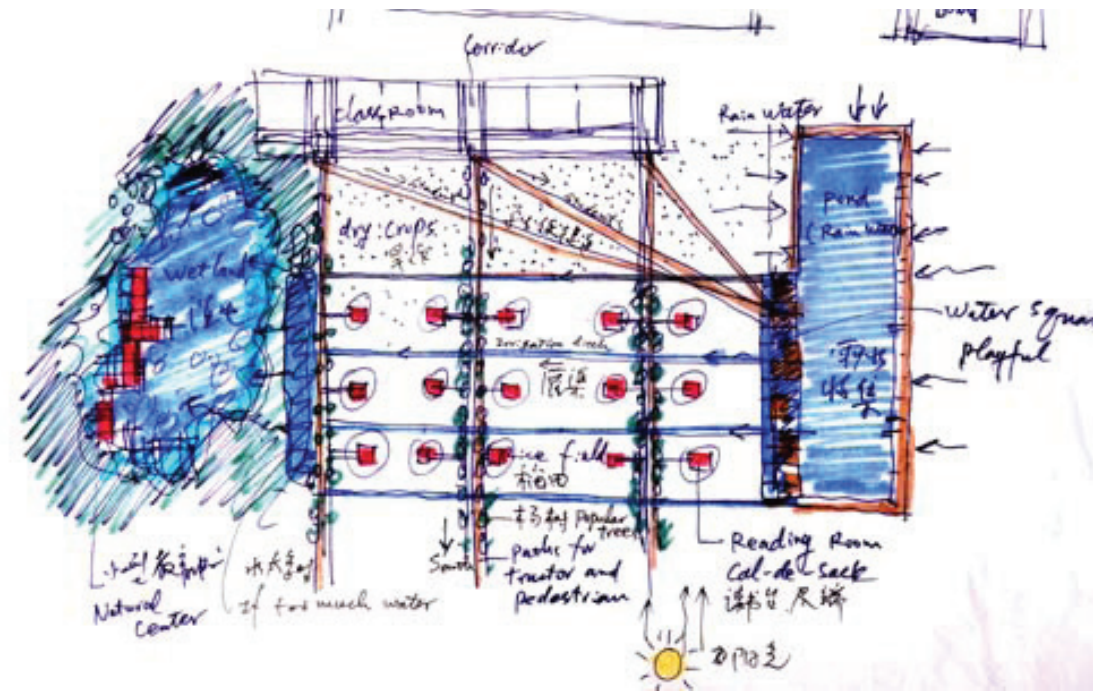

Figure 71: The system's concept and productive design development (Turenscape, 2004)



Figure 68: Social spaces created within the productive landscape (Turenscape, 2004)



Figure 69: Productive landscape complimentary to existing architecture (Turenscape, 2004)



Figure 70: Students partaking in the harvest process (Turenscape, 2004)

3.6 Urban response on Framework level

3.6.1 Layered iteration

The framework is a result of layering the following:

1. Response to the 2010 framework group.
2. Contextual response relating to the constraints and opportunities of the site.
3. The programmatic requirements.
4. The intentions.



Figure 72: Layered response to possible program (Author, 2014)

3.6.2 Proposed programme

The proposed land use is a combination of productive and social / public spaces. Public amenities and retail property is accessible to the community. The proposed residential areas are only accessible to the residents. Productive spaces are semi accessible to the public and are aimed at integrating with the surrounding fabric as if the boundaries are blurred.

Legend of proposed programme

- | | | |
|----------------|--|--|
| Public amenity | Public open space (community vegetable garden) | |
| | Public sports recreation and community centre | |
| | Public transport | |
| | Public open space (Landscape) | |
| | Public open space (Hardscape) | |
| Production | Light industrial | |
| | Productive space (Biodiversity) | |
| | Productive space (Resources for humans in landscape) | |
| Commercial | Commercial | |
| Mixed use | Residential and offices | |
| | Office and residential complex | |
| | Wetland | |
| | Office and residential complex | |
| | Productive cell | |
| | Productive space | |
| | Nursery | |
| | Community centre | |



FIGURE 73: PROPOSED LAND USES (AUTHOR, 2014)

3.6.3 Route and movement

The conceptual urban objective is to extend the new urban identity into the existing identities on either side of the site. In this way it consolidates and unifies existing surrounding land uses. The path/route is the element that integrates the surrounding urban fabric as a whole.

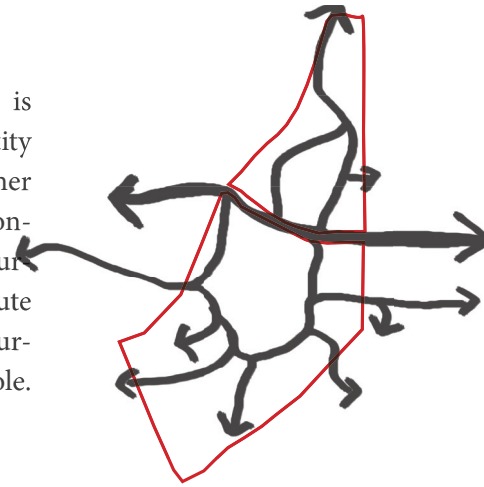

Figure 74: Urban objective diagram indicating the site, which becomes the element linking the east and the west (Author, 2014)

3.6.4 Route character

The user experiences the different land uses by travelling on the route through the site. The route's characteristics are influenced by activities adjacent to the route. These characteristics also relate to hierarchy. Routes travelled on a frequent basis is more robust. The users interaction with the production in these cases is more controlled. Seldom travelled routes allows for the user to move freely. The route typology can be seen in the following section.

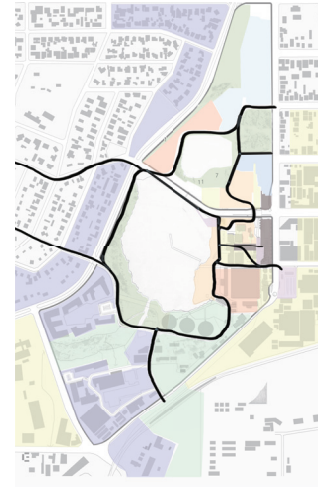

Figure 75: Conceptual layout of route on site (Author, 2014)

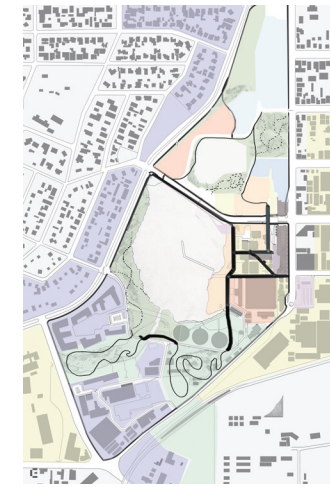
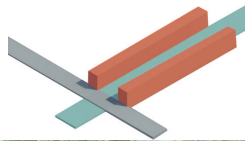

Figure 76: Conceptual hierarchy of route (Author, 2014)

3.6.4.1 Route typology

1. Vehicular movement:

Pedestrian routes have higher importance than vehicular routes. Vehicular movement is therefore limited by the implementation of a one-way road within the precinct boundaries. The route is defined and separated from the surrounding functions.



2. Entrances and landings:

The entrances introduce the site. These are orientation points with information displays regarding the site and its productions. Information boards blend with the surroundings. These spaces have an open feeling



3. The main circulation route / thoroughfare.

The main objective is to enhance mobility and movement of pedestrians. This route connects regularly visited areas and integrates the precinct as a whole. The materiality accommodates high usage. This route intersects with other route typologies. There is a clear distinction between functional, operational or service amenities and public amenities along the route.

Uses:

- a. Recreational
- b. Functional/operational services
- c. Cyclist

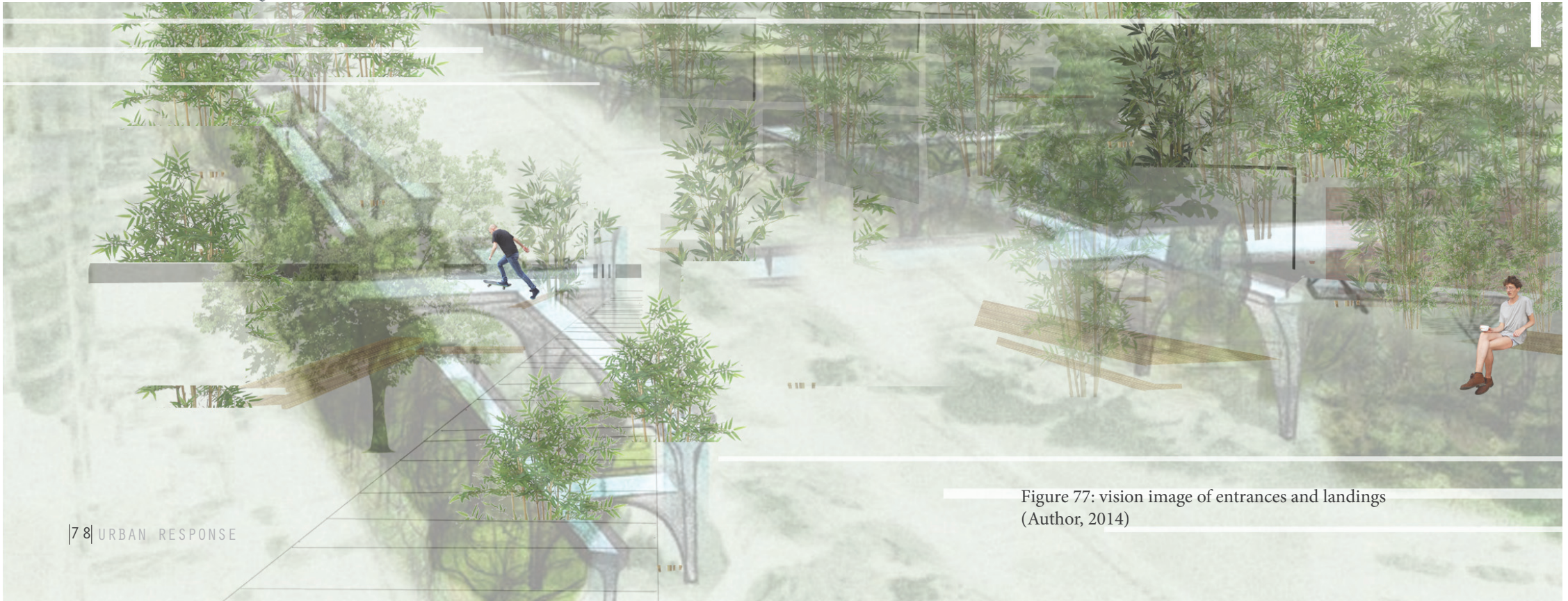
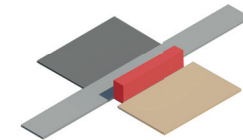

Figure 77: vision image of entrances and landings
(Author, 2014)

4. Secondary pedestrian circulation

These will be walkways that connect the occasionally visited spaces. This route branches from the main circulation route. The route interface between productive spaces and public amenities are thus blurred.

Uses:

- a. Recreational
- b. Cyclist

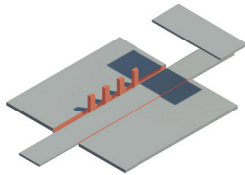

5. Dissipating

The dissipating route gives the user the freedom to explore. The route is not defined and spaces blend into one another; there are different options and the direction of the route is not defined.

Uses:

- a. Recreational
- b. Horse trail

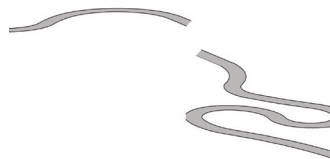

6. The trail

This route meanders through sensitive ecological areas exposing the user to natural systems

Uses:

- a. Recreational

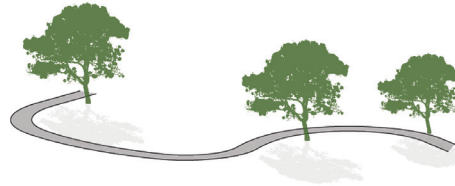

Figure 78-82: Figure series indicating route typology (Author, 2014)

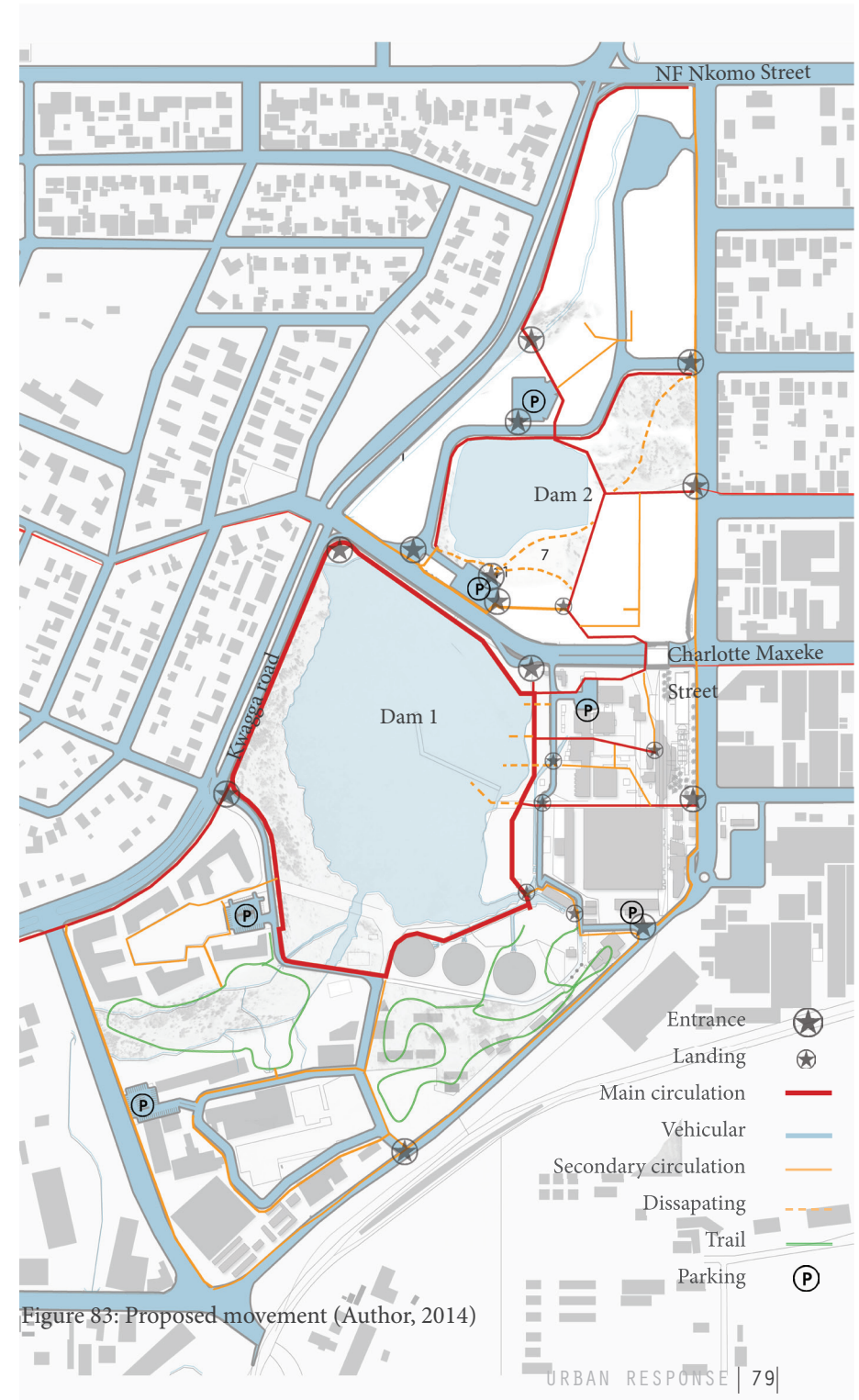

Figure 83: Proposed movement (Author, 2014)

3.6.5 Framework result: Route interaction with Production











Public space linear time	Productive space /cyclical time
1. Tea garden	Aeration weir-water exiting into the Steenhoven spruit
2. Horse trail and patrolling trail	Green house where bamboo is grown
3. Existing community centre	Indigenous veld, additional horse forage
4. Walking trail towards community centre	Water treatment with indigenous reeds and tilapia fish
5. Picnic space	Horse paddock
6. Orientation point	Greywater treatment
7. Walkway	Bamboo production
8. Thorough fare (Pedestrian bike and horse)	Biophilic water edge
9. Thorough fare (Pedestrian, bike and horse)	Biophilic water edge
10. Bus stop	Bamboo drying kilns



Figure 84: Interaction points on site

- 11. Pedestrian corridor — Furniture workshop
- 12. Pedestrian corridor — Clothing manufacturer
- 13. Pier as a social option — Access to water
- 14. Promenade — Bamboo forest
- 15. Water edge promenade — Biodiversity park
- 16. Residential / office — Agriculture
- 17. Horse trail / running — Wetland
- 18. Mixed use — Community production
- 19. Pedestrian entrance — Community agriculture

Legend of proposed programme

- | | | |
|----------------|---|--|
| Public amenity |  | Public open space (community vegetable garden) |
| |  | Public sports recreation and community centre |
| |  | Public transport |
| |  | Public open space (Landscape) |
| |  | Public open space (Hardscape) |
| Production |  | Semi industrial |
| |  | Productive space (Biodiversity) |
| |  | Productive space (Resources for humans in landscape) |
| Commercial |  | Commercial |
| Residential |  | Residential and offices |

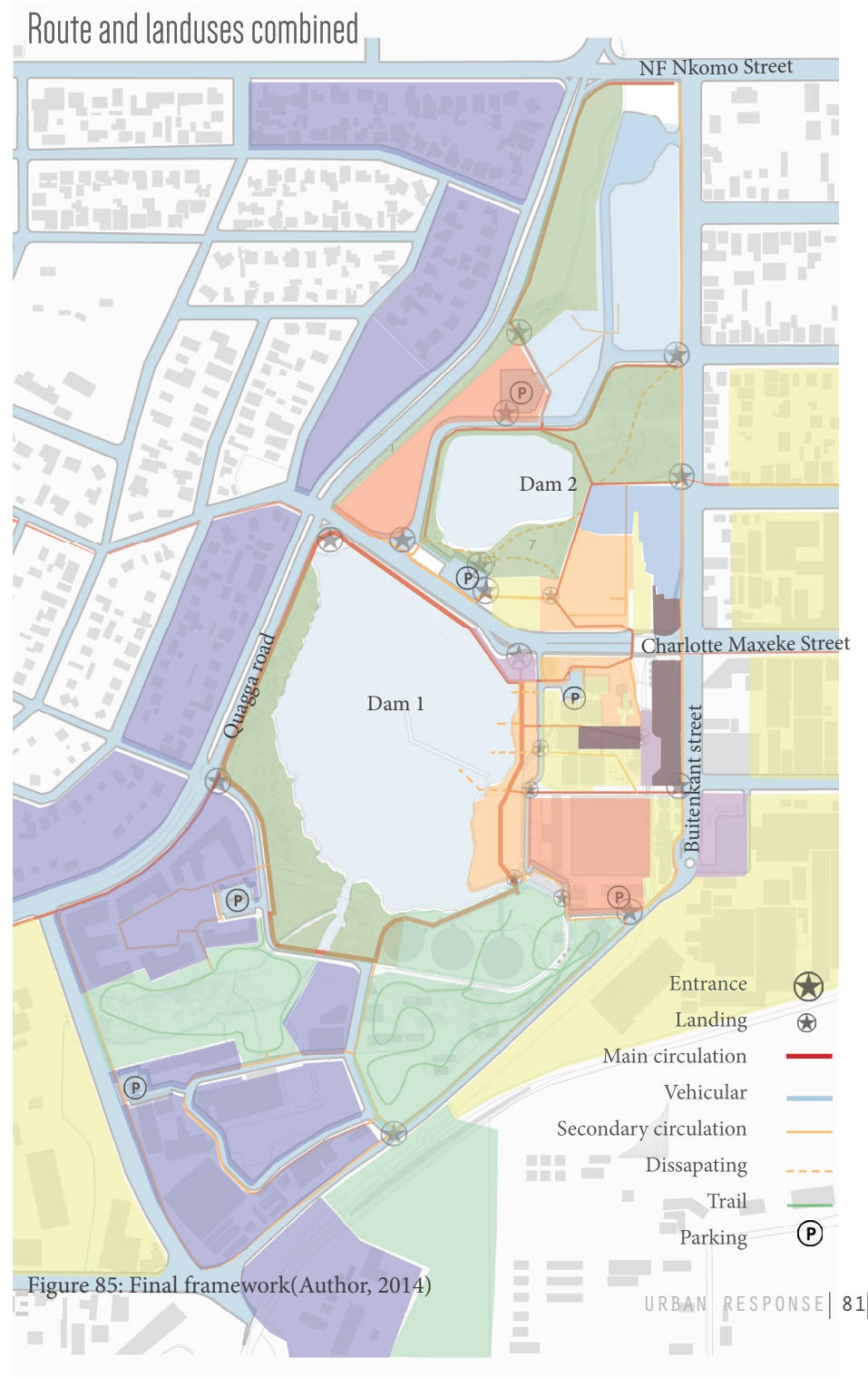

Figure 85: Final framework (Author, 2014)

4 . CONCEPT EVOLUTION

FOR MASTER PLAN AND SKETCH PLAN

4.1 General intentions

The general intention is to subject the user to different forms of production. The aim is to make the user aware of their consumerist nature. This landscape can become a precedent of how productive landscapes can become spatial informants in urban environments. Productive landscapes in urban environments minimise the import of products to the urban centre and capitalises on the re-use of brown field sites.

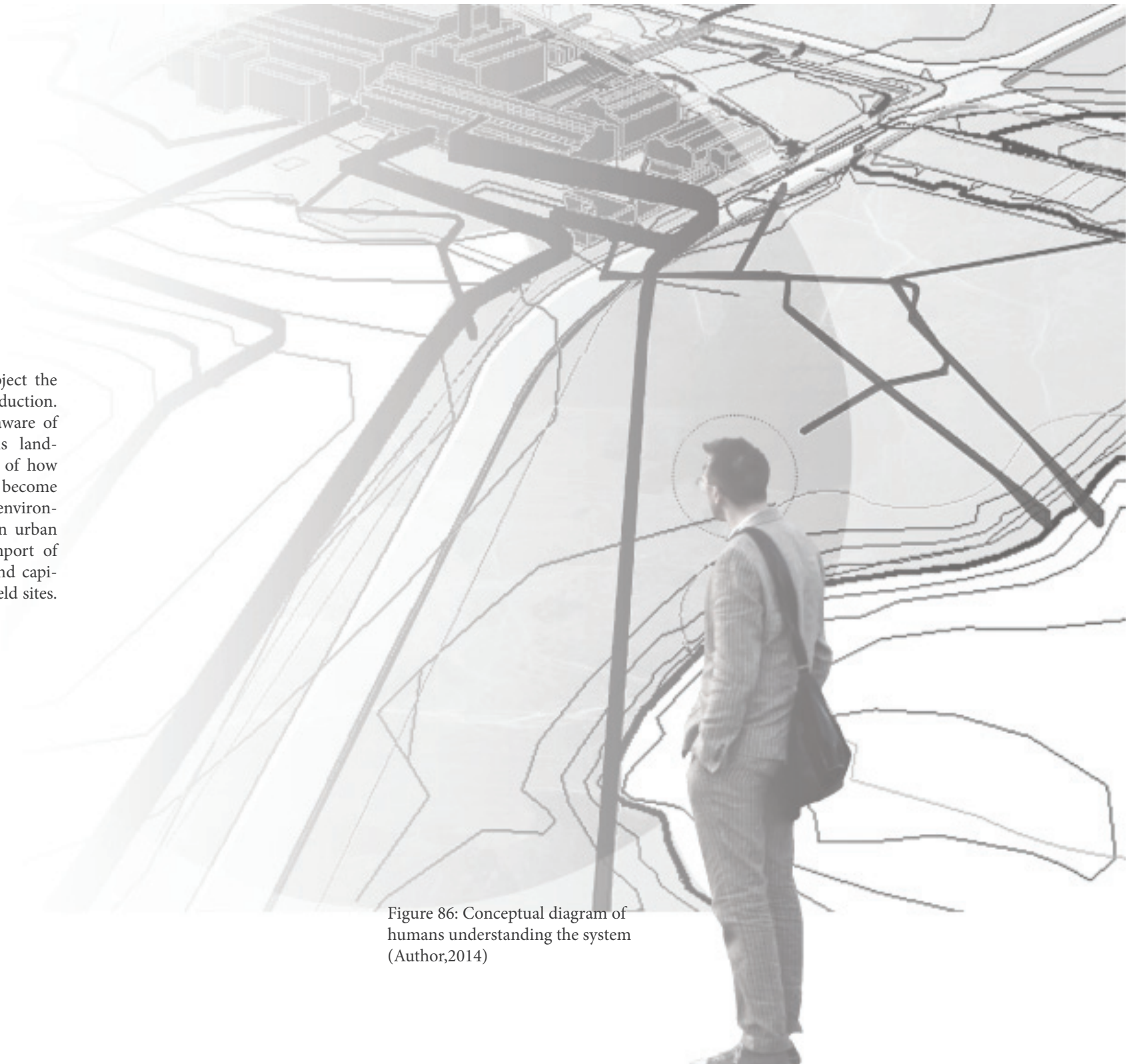

Figure 86: Conceptual diagram of humans understanding the system (Author,2014)

4.2 Specific intentions

4.2.1 Programmatic intent

The programme discussed in the previous chapter is an integration of productive light-industrial spaces, such as bamboo crop areas, bamboo processing areas and water treatment areas, combined with public spaces such as picnic areas, a thoroughfare, a waterfront and a public square.

4.2.2 Urban intent

The urban intention for the precinct of the Pretoria West Power Station is to introduce a new typology of urban form that stretches across the power station, creating unity between the east and the west.

4.2.3 Contextual intent

The site displays a timeline from 1930 to contemporary industrial architecture. The context is a modifier and not a determinant of the design outcome. The existing context plays a role in shaping the proposed design, but the heritage design is not the main objective. The design is proposed to contextually respond to the tectonics on site. As an example, the proposal will respond to the existing industrial forms, materials and layout of the precinct.



Figure 87: Vision image of productive landscapes combined with public space (Author, 2014)

4.3 Spatial/Architectural intentions

The intervention introduces a productive landscape that evokes a psychological resonance in the user. To achieve a dialogue between the user and the productions, the landscape provides a transparent interface between the user and the productive landscape. The word transparency relates to the prominence and visibility of productive entities and subsequently how the user understands them.

The interface is where biophilic design guidelines will be followed to achieve a positive psychological effect. The space-making is not addressed by haphazardly implementing biophilic guidelines into the scheme, but is introduced through a conceptual medium. A space-making concept is derived by assessing the overlapping qualities of the productive, social and ecological spaces.

4.4 Concept terms

The landscape has three different land uses: a public space; a space where biodiversity can flourish; and the productive landscape. The three different landscape applications have one thing in common, which is the construct of time.

4.4.1 Construct of Time

Landscapes have the ability to display a passing of time. Both the social spaces and the living landscape reflect passage of time through a series of ritual, routine and seasonal change. This results in a montage effect where a series of interactions can happen within different time frames. In other words, a user will experience the landscape in many different ways due to the changes that occur in the landscape.

There are two constructs of time applicable to the site.

1. The route that the user travels through the site. The user's construct of time is therefore linear in nature because he/she enters the site, experiences the landscape and leaves the site. The User's journey has a beginning and an end.
2. Each production is cyclic in nature. The significance of each step in the cycle shifts within a time frame like a series of cogs completing their circles at different times. Natural systems are also cyclic in nature according to season and stage within a plants life. The cycles all move at different rates



Figure 88: User's linear construct of time (Author, 2014)

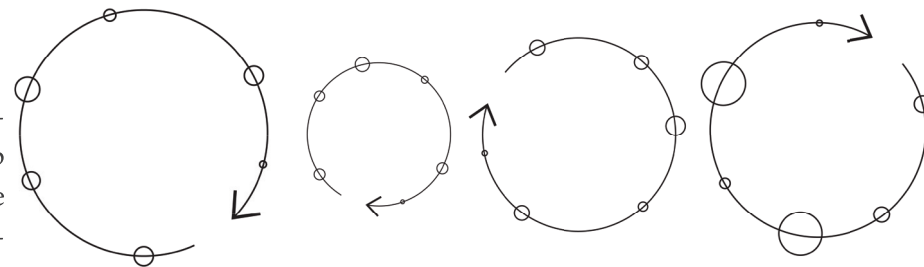

Figure 89: Biodiversity and production's cyclic construct of time (Author, 2014)

The point where the 2 time constructs intersect is where communication of the production with the user will occur. Each time the user moves through the site, the experience will be different. The user will be more aware of the surroundings if the landscape changes drastically. Sensory changes in the user's everyday landscape will have a positive psychological effect that will allow for a mind shift in the user about the impact that production has on the environment. The user will have a greater appreciation for products, as they understand and experience the making thereof.

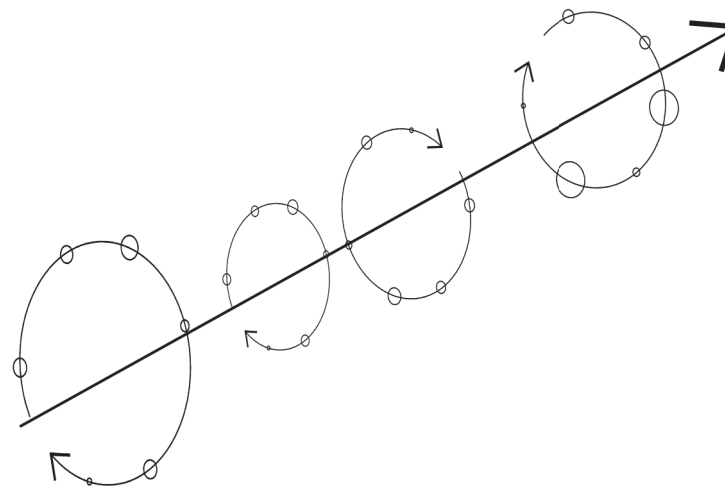

Figure 90: Time as a linear construct is in contrast with cyclical time (Author, 2014)
Image adapted from Adaptable Futures, toolkit Do1 :integrating context.

4.4.2 Enthalpy change

The definition of enthalpy change in terms of this dissertation: Enthalpy can be described as the change in energy in a system over time. Each of the productions on the site undergoes a cyclic change in energy within its own time frame. Change over time is a conceptual form driver. The production processes involved all work on a time cycle which repeats itself, as illustrated in the figure 91.

An example within the dissertation is the bamboo cycle. The annual bamboo production cycle is as follows:

In the month of August 33% of the bamboo clump is harvested. The drying process then occurs between August and November. Between October and February new bamboo

culms grow 21 meters before maturing. Harvested culms are simultaneously processed to be manufactured by the furniture and clothing warehouses between the months of October and July. The cycle then repeats.

The individual changes that occur within the individual processes are thus the form drivers for the public spaces.

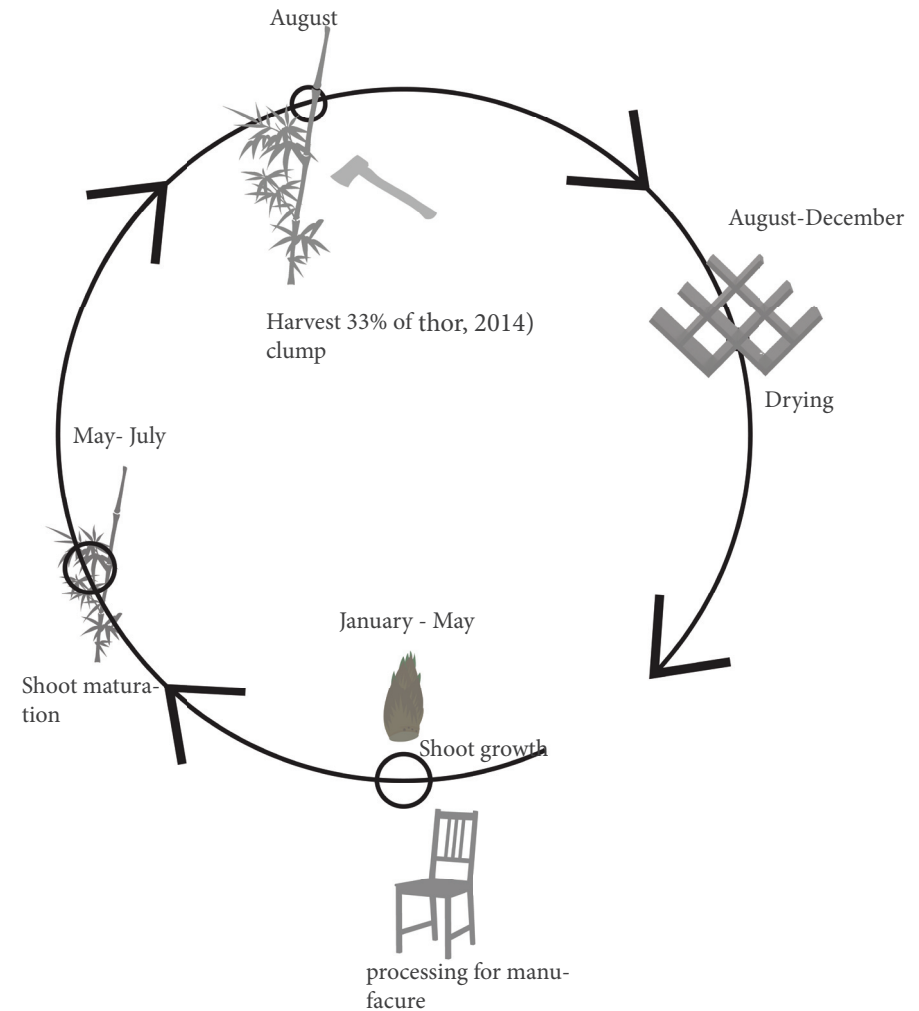

Figure 91: Processes within the bamboo production that will inform space (Au-

4.4.3 The travelled route

Activities drive the user group through the site. The movement has different velocities. Public spaces between places of production are where the user's involvement with the processes becomes the most prevalent. The routes are classified according to a hierarchy of use. The route becomes the medium through which change in time is expressed.

The path to space relationship is used as a departure point to design the dialect and portray the interaction (Ching, 2007). Francis D.K. Ching's 3 ways of path space relationship has been explored within the framework of the site.

The 3 ways in which the path holds relationship with space are indicated in figure 92

1. Path terminating in a space
2. Path intersecting a space
3. Path running along a space.

More emphasis is placed on point 2, intersecting space, as the peripheral vision has more importance on subconsciously affecting the user, as mentioned in the theoretical premise.

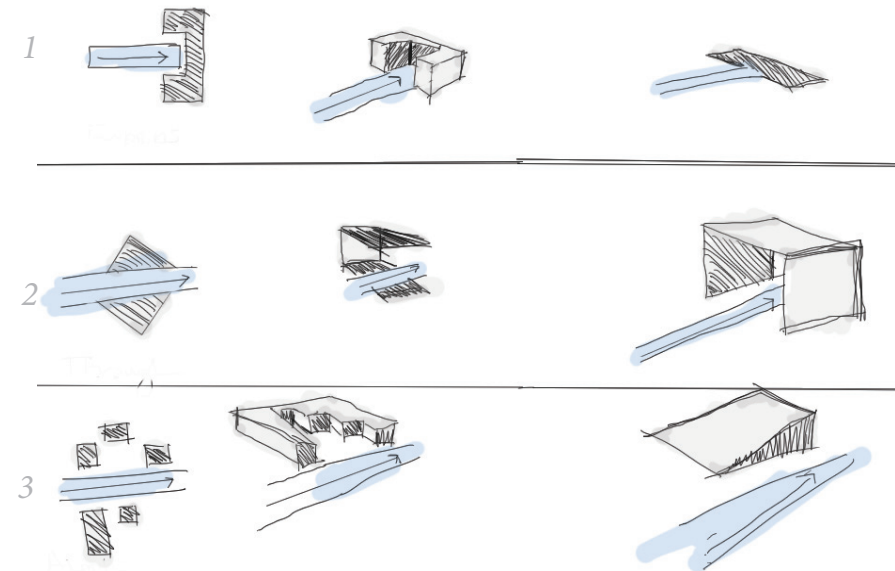

Figure 92: Exploration of Francis DK Ching's path to space relationship (Author, 2014)

4.4.4 Space

The spaces are affected by the (cyclical) productions around the space combined with the movement of people. The space reflects a communication between the users and their productions. This concept is reflected in figure 93 where productions are designed along with the route and as a result informs how the space is shaped the space has to reflect this communication between man and the production.

4.4.5 Interface

4.4.5.1 Applicable Biophilic design guidelines:

Applicable design guidelines were followed according to the biophilic elements present on site:

1. The interaction with the water body.
2. Emphasising aging elements on site, such as weathered concrete and rusted metals, with contrasting new materials
3. Presence of natural elements
4. Incorporating natural patterns

4.4.6 Summarised concept

The following parti diagram is a summation of the concept terms mentioned

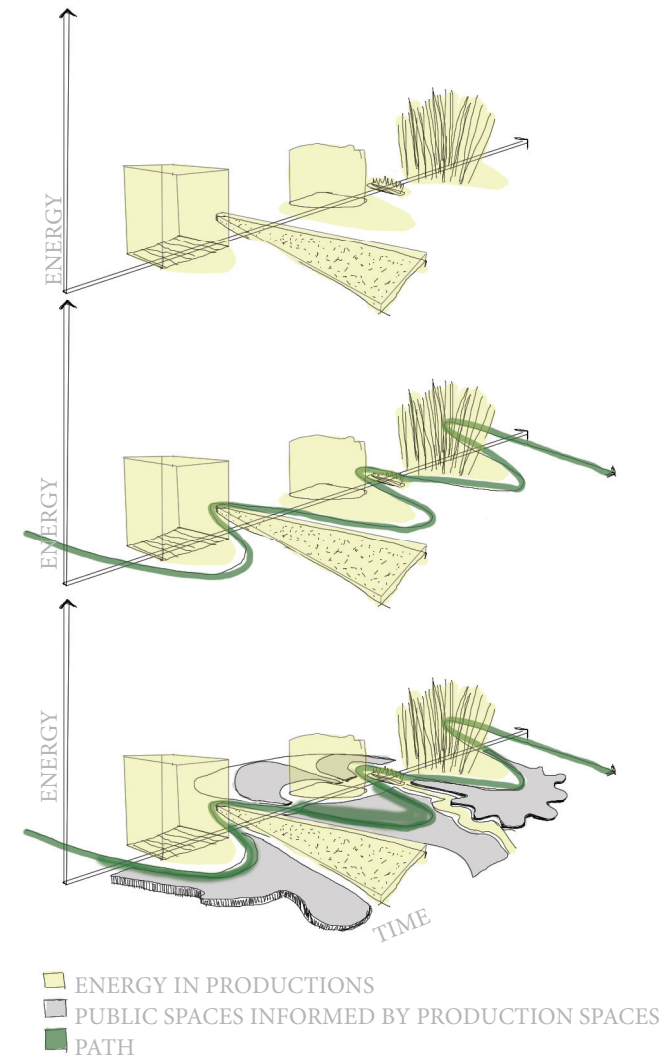
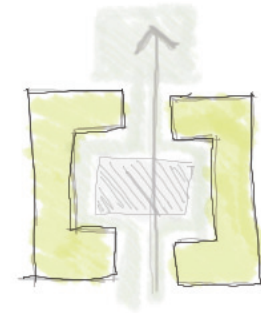

Figure 93: The path to space relationship as indicated through the concept of enthalpy (Author, 2014)

4.4.6.1 Parti diagram displaying concept intentions

Productions(cyclical in nature)



Linear movement through site



Public space

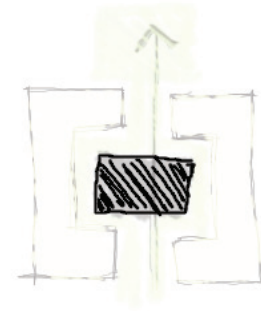

Biophilic elements



4.4.6.1 Parti diagram displaying concept intentions

Productions(cyclical in nature)

Linear movement through site

Public space

Biophillic elements



Figure 94: Parti diagram (Author, 2014)

5. DESIGN DEVELOPMENT

FOR MASTER PLAN AND SKETCH PLAN

5.1 Master plan site

5.1.1 Introduction

The design is developed on the premise that a dialogue between the user group and the productions on site can be established. The narrative of production is communicated to the user through a series of spaces along the most frequently travelled route, instead of a nodal intervention.

The focus area is the area where the highest number of interactions between productive and public spaces takes place. It includes interaction of the existing productive buildings and the proposed landscape productions. Figure 95 indicates the area where most of the productions occur.



Figure 95: Master plan site identification
(Author, 2014)

5.2 Understanding the site

5.2.1 Levels

The chosen focus area has been drastically altered over the years. As a result, vast level changes occur on site. The availability of information on levels done by the framework group is limited. The levels indicated in figure 96 are the assumed levels and are used as the existing levels for this dissertation. The level changes were altered by the author.



Figure 96: Levels of master plan site
(Author, 2014)

5.2.2 Existing masterplan programme

5.2.2.1 Productive spaces in master plan:

- Furniture manufacture
- Hydroponic food farm
- Horse stables
- Clothing factory

5.2.2.2 Social spaces in master plan:

- Train station
- Sunken garden
- Public square

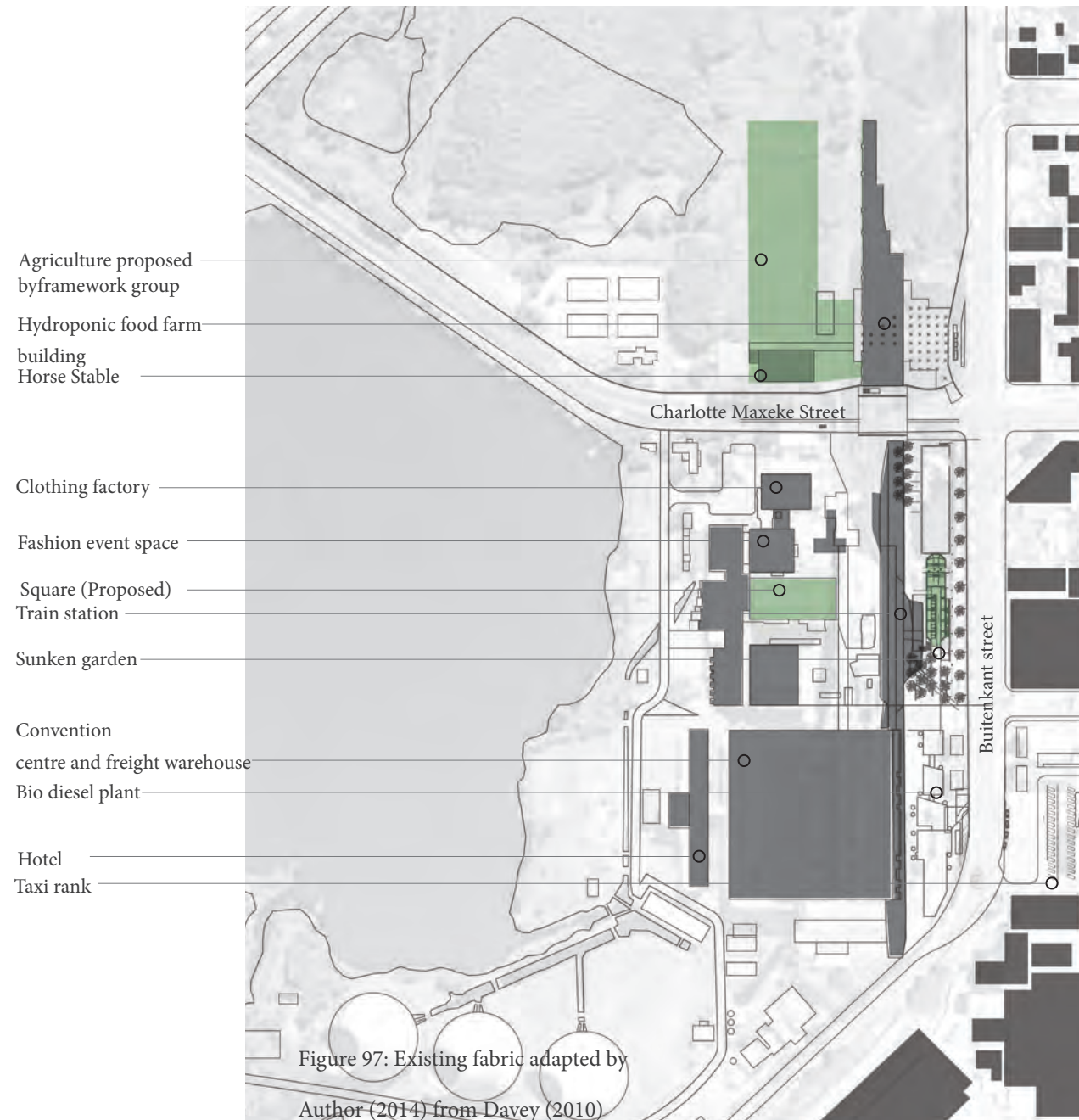

Figure 97: Existing fabric adapted by

Author (2014) from Davey (2010)

5.2.3 Proposed master plan programme

5.2.3.1 Spaces in master plan:

The intention is to create a connected series of public spaces, informed by productions. People filter through the train station from the taxi rank. The waterfront becomes an extension of the square.

Buildings:

- Timber and textile buy-back centre
- Greenhouse
- Bamboo warehouses

Landscape

- Bamboo cultivation
- Water treatment
- Equine environment
- Square



Figure 98: Proposed programme
(Author 2014)

5.2.4 Circulation on Upper level

Users that arrive on site at level 1 arrive via bus, taxi, private vehicle or on foot from either Buitenkant Street or Charlotte Maxeke Street. This level of the master plan aligns with the level of the promenade running along the eastern edge of the upper dam. The true height of this level is 1331.520 metres above sea level.

5.2.5 Circulation on lower level

If the user arrives by train, they have the option to enter the site on the level of the square. The true height of this level is 1327.563 metres above sea level. Entrances to the fashion event space, restaurant, internet cafe, public ablutions and furniture showroom are on this level. The circulation allows for access to the individual functions as proposed to celebrate the productive nature each building offers.

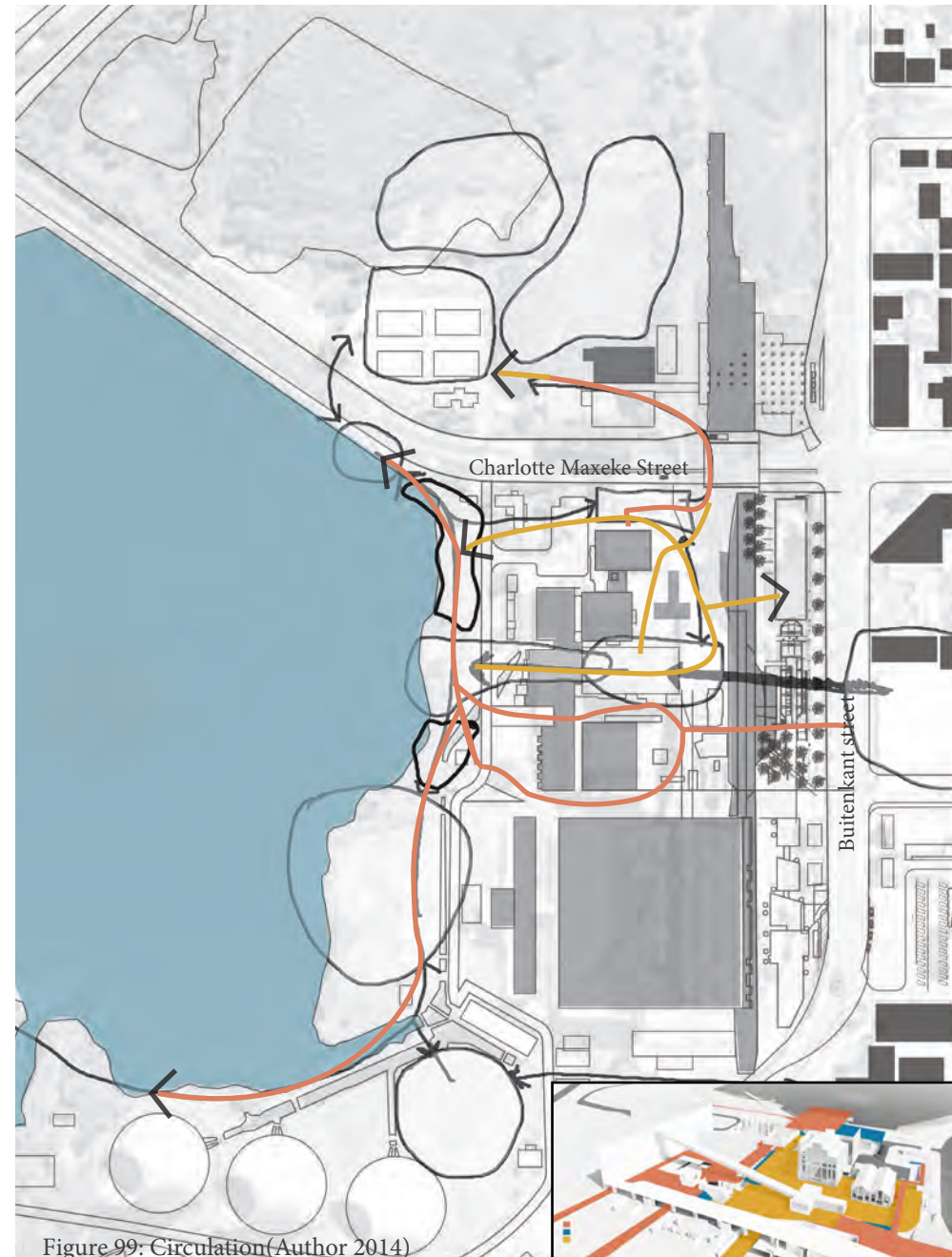

Figure 99: Circulation (Author 2014)

5.2.6 Master plan Iteration



Figure 100: Guiding people through the site (Author, 2014)

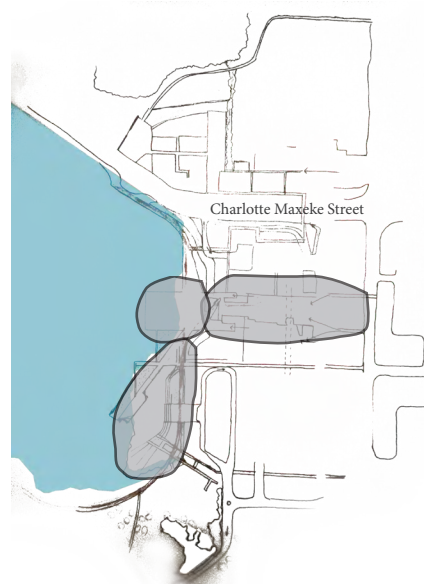

Figure 101: Waterfront becomes transitional space between urban and events landscape, which reads as a softer landscape (Author, 2014)



Figure 102 Vehicular movement(Author, 2014)

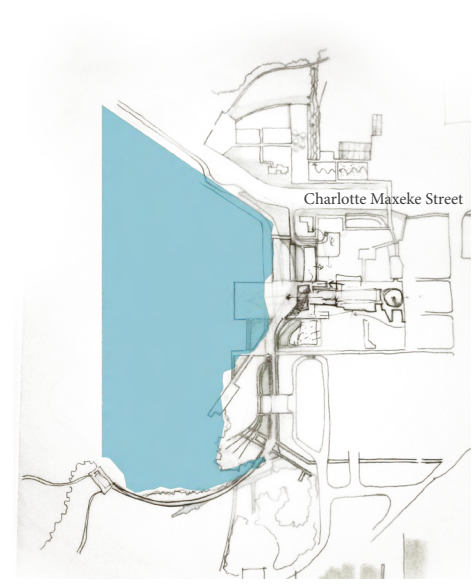
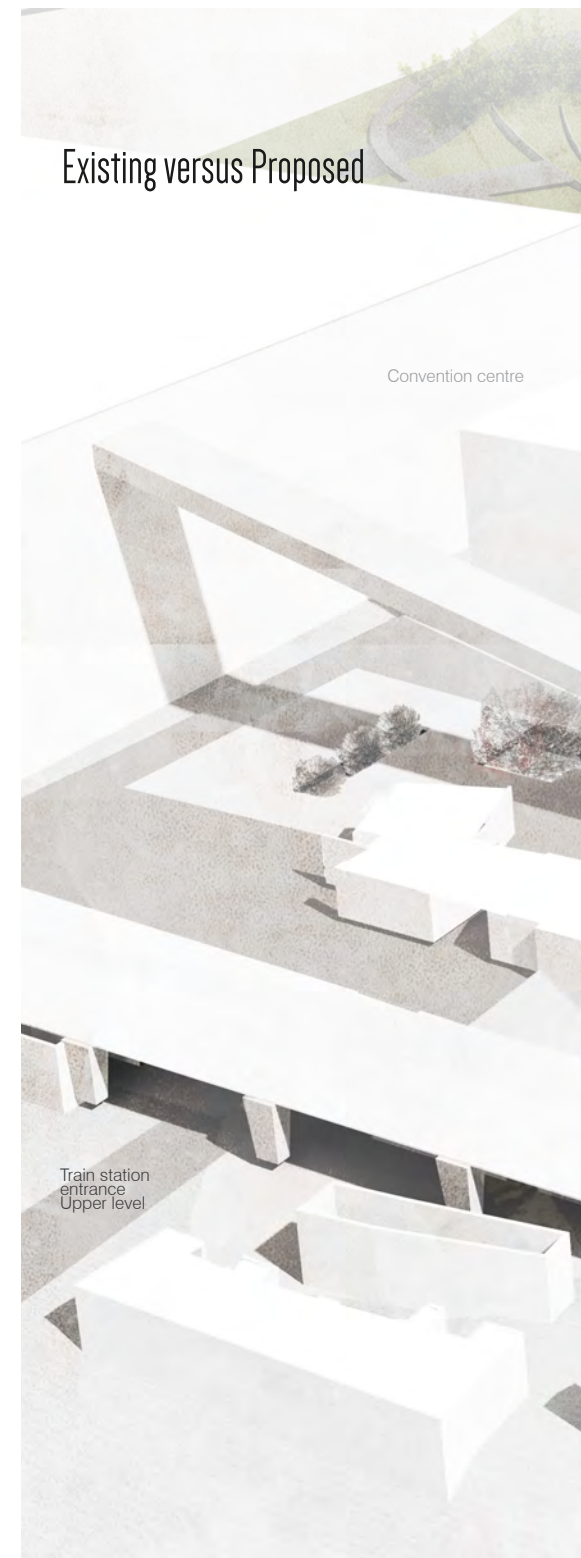

Figure 103: Masterplan iteration 4(Author, 2014)



Figure 104 : Final master plan n.t.s (Author, 2014)





Sketch plan determination

The master plan gives context to the sketch plan. The waterfront, as an extension of the square, was chosen. This is the area with the highest pedestrian traffic, and highest possibility of interaction with productions. The square becomes the nucleus from which all the master plan activities stem.

2. The site has to display the productions in a biophilic way in order to have a positive effect on the user.

In the following section, precedents are consulted to achieve the above-mentioned intentions on sketch plan level.

5.2.2 Design intentions

On master plan level, the organisation of the programme has been laid out according to interactions between man and production. In order to assure the required interaction on a detailed level, precedents of schemes with similar intentions were investigated.

Scheme intentions for sketchplan design:

1. Create landscape spaces, which have educational value. Design the space in a way that informs the users of productions in a non-obtuse manner. It should rather be integrated with the existing and proposed fabric, than being a candid element of the landscape, existing in isolation

5.3 Precedent studies

5.3.1 Educational value

Project details

Qinhuangdao botanic garden by Turen-
scape

Qinhuangdao City,
Hebei, China

26.5 Hectares

Objectives:

- Public open space to allow public to visit freely.

- For the landscape to become a tourist attraction.
- Education facility for communities to learn about native plants and vernacular landscapes.

How is the landscape designed to educate the user:

The landscape is divided into different scenes or settings. An example of these changes is how the vegetation communities change according to soil types. For a unique educational experience, the landscape is moulded and cut.

The level changes dramatise the difference between one space and the next to give understanding to the vernacular landscape. An example is visible in figure 104, where an artificial valley is cut out of a mound. The bridge crossing the valley enables the user to view the landscape from an alternative perspective and gain an understanding of the geological layers.



Figure 105: Artificial valley created by Turen scape as an educational tool to educate users of surrounding geology (Landezine/ landscape architecture works, 2012)



Figure 106: Shading structures designed to accommodate climbing plants (Landezine/ landscape architecture works, 2012)



Figure 107: Definition between spaces emphasises different spaces communicating different ideas (Landezine/ landscape architecture works, 2012)

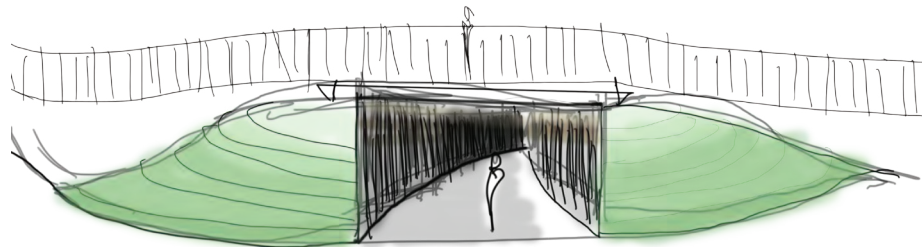

Figure 111: Artificial valley created by cutting out of artificial mound (Author, 2014)

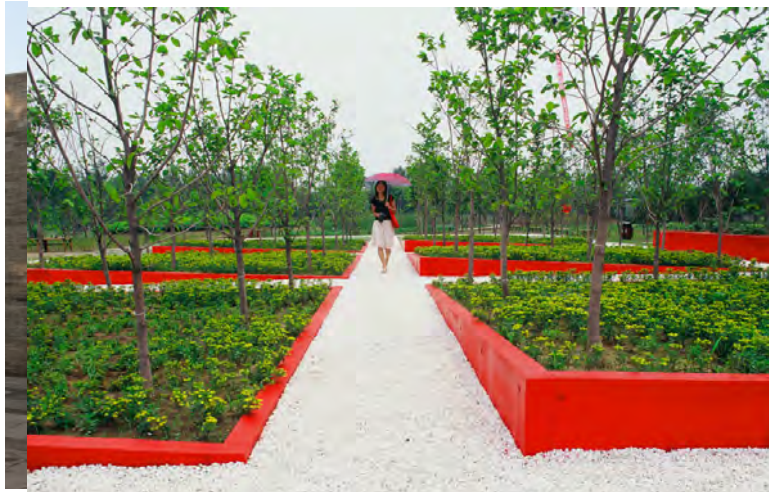

Figure 108: Turenscape uses colour in homogenous spaces to create interest (Landezine/ landscape architecture works, 2012).



Figure 109: Axis of soil displaying different soil types from rocky to loam(Landezine/ landscape architecture works, 2012)



Figure 110 Pathways and bridges are designed to connect interest views (Landezine/ landscape architecture works, 2012)



FIGURE 112: PHOTOGRAPH OF CORRODED METAL PIPES ON SITE (AUTHOR, 2014)

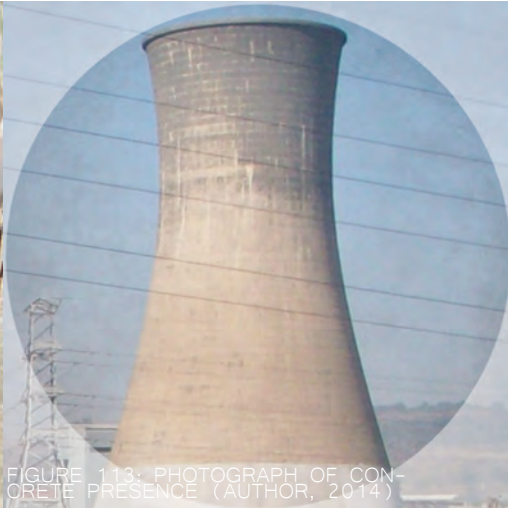

FIGURE 113: PHOTOGRAPH OF CONCRETE PRESENCE (AUTHOR, 2014)



FIGURE 114: RED CLAY BRICKS ON SITE (AUTHOR, 2014)



FIGURE 115: COAL ON SITE (AUTHOR, 2014)



FIGURE 116: WATER ON SITE (AUTHOR, 2014)



FIGURE 117: VERTICAL METALS ON SITE (AUTHOR, 2014)

12 DESIGN DEVELOPMENT

Translation into scheme

The movement through spaces and the transition from one identity to the next is applicable to the sketch plan site. The vernacular of the Pretoria West Power Station is of an industrial kind, The landscape can educate the user by responding to the vernacular elements of the site, as shown in figures 112-117

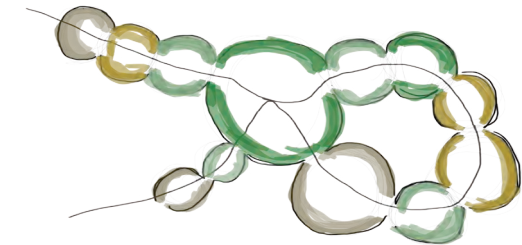

Figure 118: Diagram of different landscape identities assisting in the educational value of the landscape (Author, 2014)

5.3.2 Biophilic design intentions

Project details

The Forest @ Pyne
by Sansiri by TROP
Bangkok, Thailand
2900 m2

Objectives:

- The main objective was to provide open space to a high-rise condominium building..
- To create a feeling of seclusion from the busy urban surrounds
- The objective was to create an urban forest.

To subject the users to nature, perpendicular lines were avoided and only angled lines combined with curves were used. The Forest @ Pyne has the biophilic intention of creating an oasis for residents in the city.

Translation into scheme:

The precedent is applicable in terms of the application of biophilic theory. The materials and forms used is an interpretation of the concept of creating an urban oasis. The materials used were natural combined with synthetic. The synthetic

as a juxtaposition places emphasis on natural and man-made materials.

Seclusion was one of the primary design objectives. This was achieved by creating a space, that contrasts with its urban surrounds. The marble wall defines the edge of the park and gives the users a sense of seclusion. A critique is that the site isolates itself from the surrounding urban fabric, but in this case, it is appropriate for a condominium building.



Figure 119: Tributary Rivers flowing to the water body is a clear conceptual driver seen in this image (Landezine/ Landscape architecture works, 2014)



Figure 120: Sculptures are an extension of the forest concept (Landezine / Landscape Architecture Works, 2014)

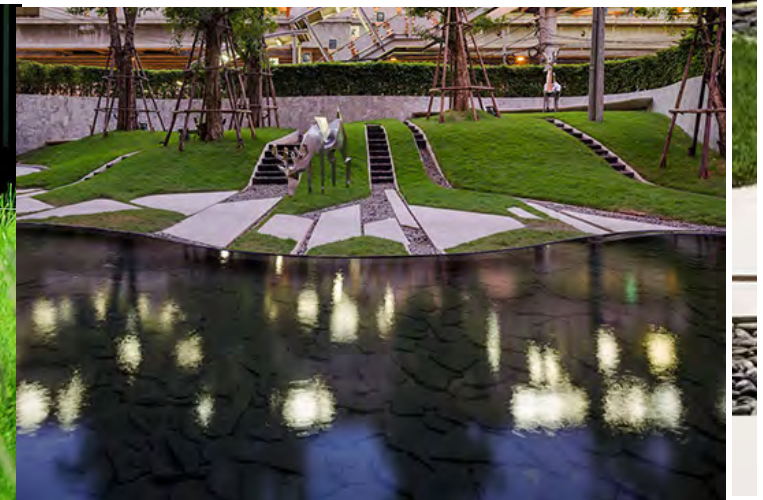

Figure 121: Mounds create the perception of a natural landscape (Landezine/Landscape architecture works, 2014)



Figure 125: A TROP section adapted to portray the seclusion achieved by the design of the forest @ Pyne (Author, 2014)



Figure 122: Natural materials contrasted with synthetic shaped concrete (Landezine/Landscape architecture works, 2014)



Figure 123: The marble wall defines the edge of the park (Landezine/Landscape architecture works, 2014)



Figure 124: Vines crawling up the side of a tree is suggested in the green wall as an extension of the forest concept (Landezine/Landscape architecture works, 2014).

5.4 Design response

A spatial relationship diagram is used to organise the flow of different spaces into one another. The spatial relationship diagram aims to apply the design intentions through the use of the concepts mentioned in chapter 4.

5.4.1 Spatial relationship diagram displaying concept intentions

- Productions (cyclical in nature)
- Linear movement through site
- Public space
- Biophilic elements

Productions(cyclical in nature)

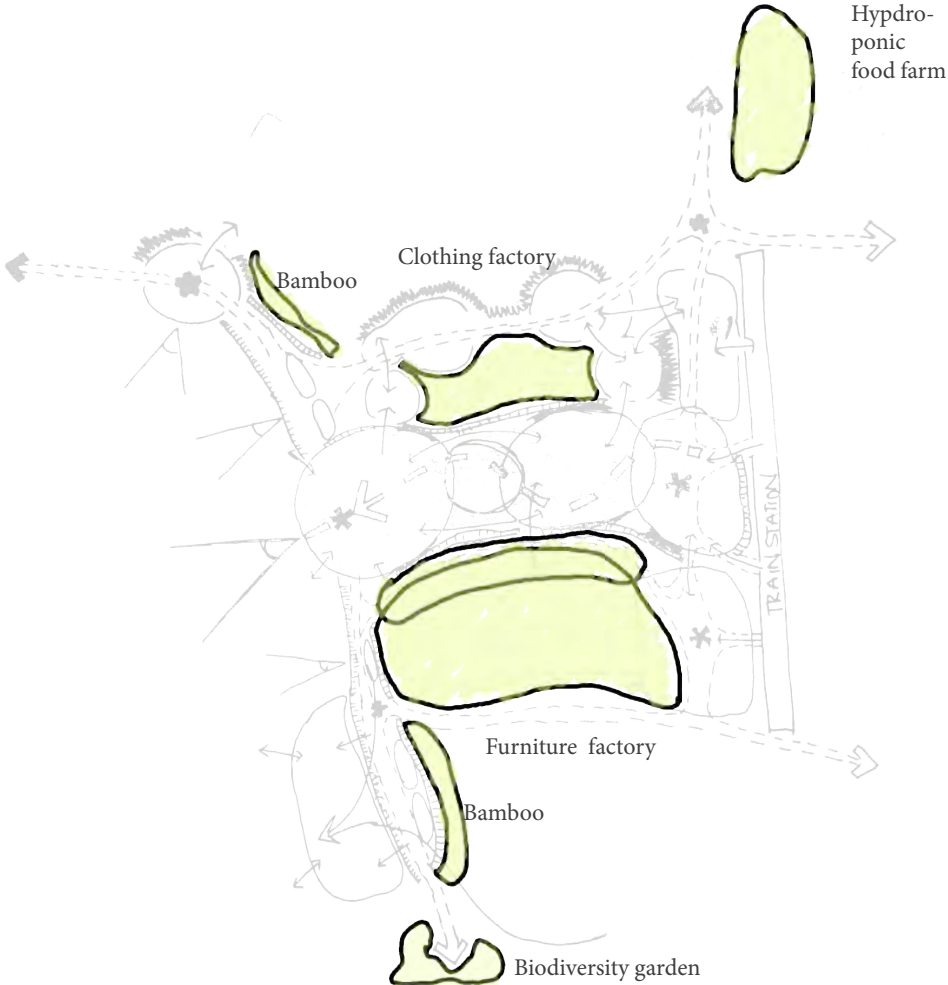

Movement through site (Linear time)

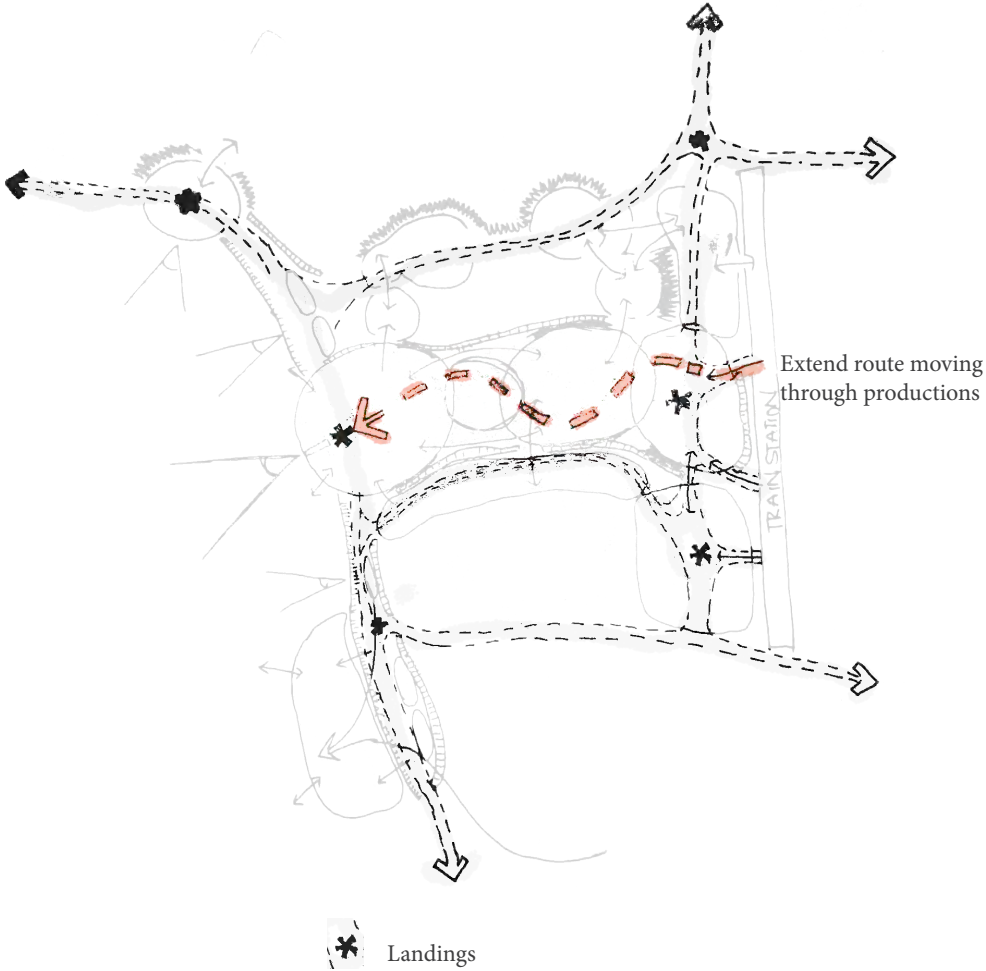

Public space

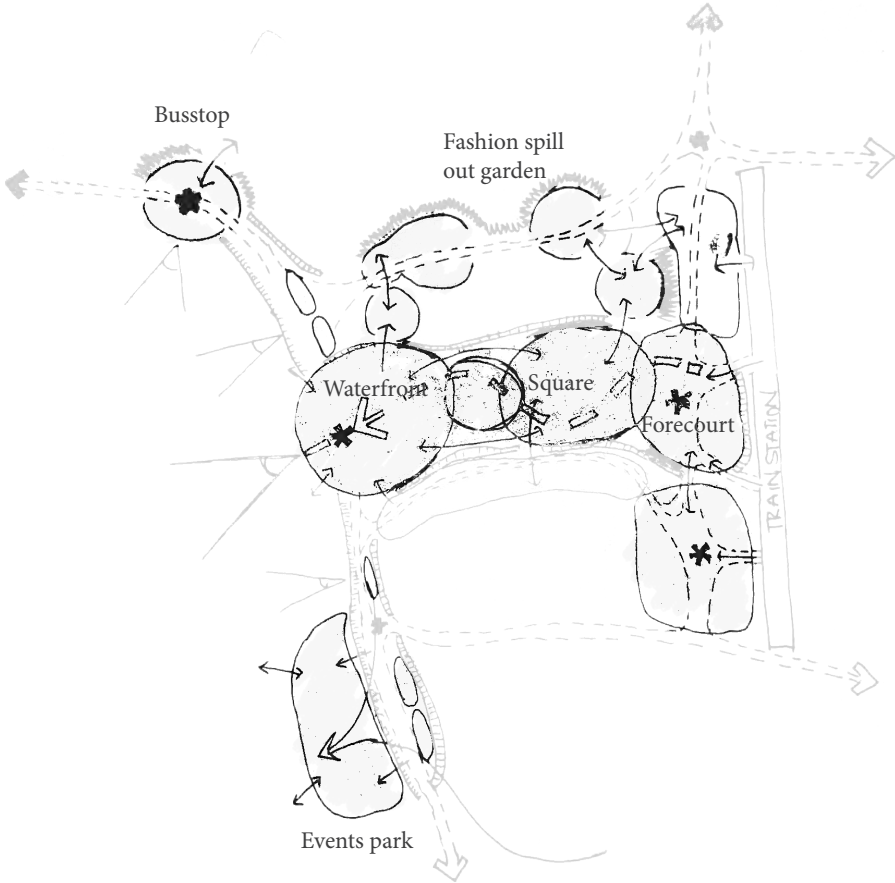

Biophilic elements

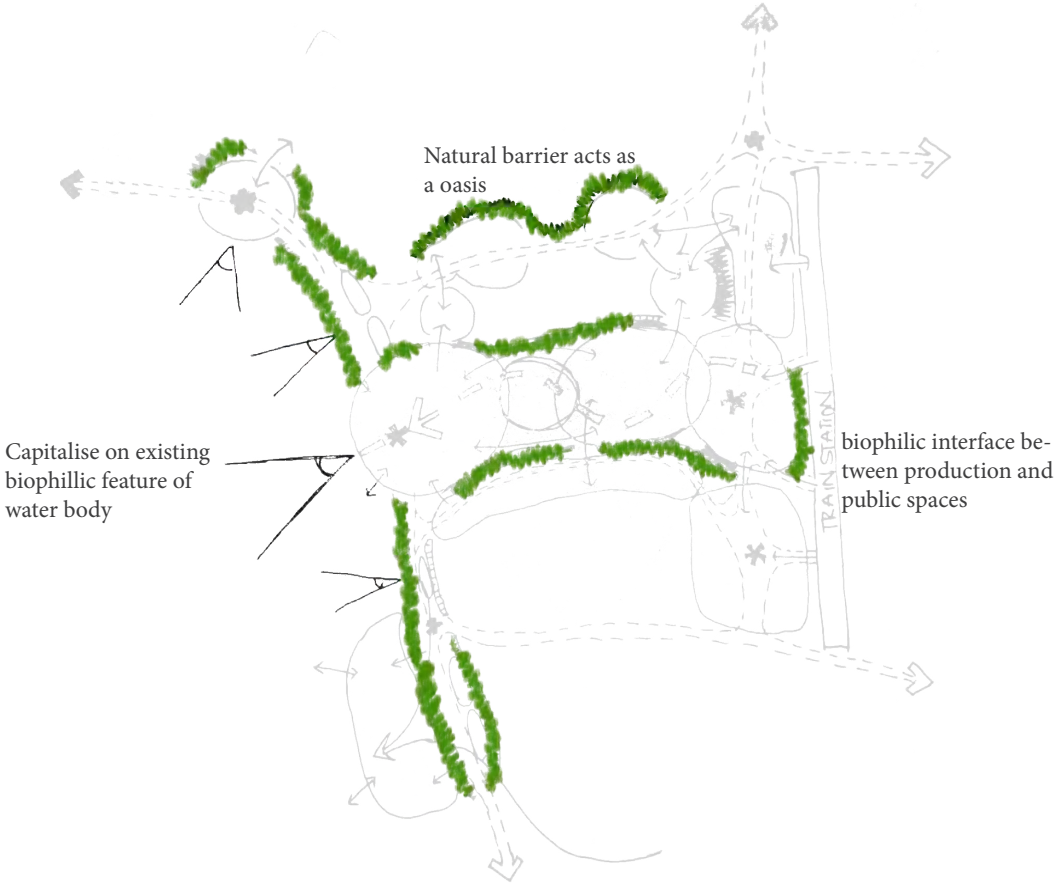

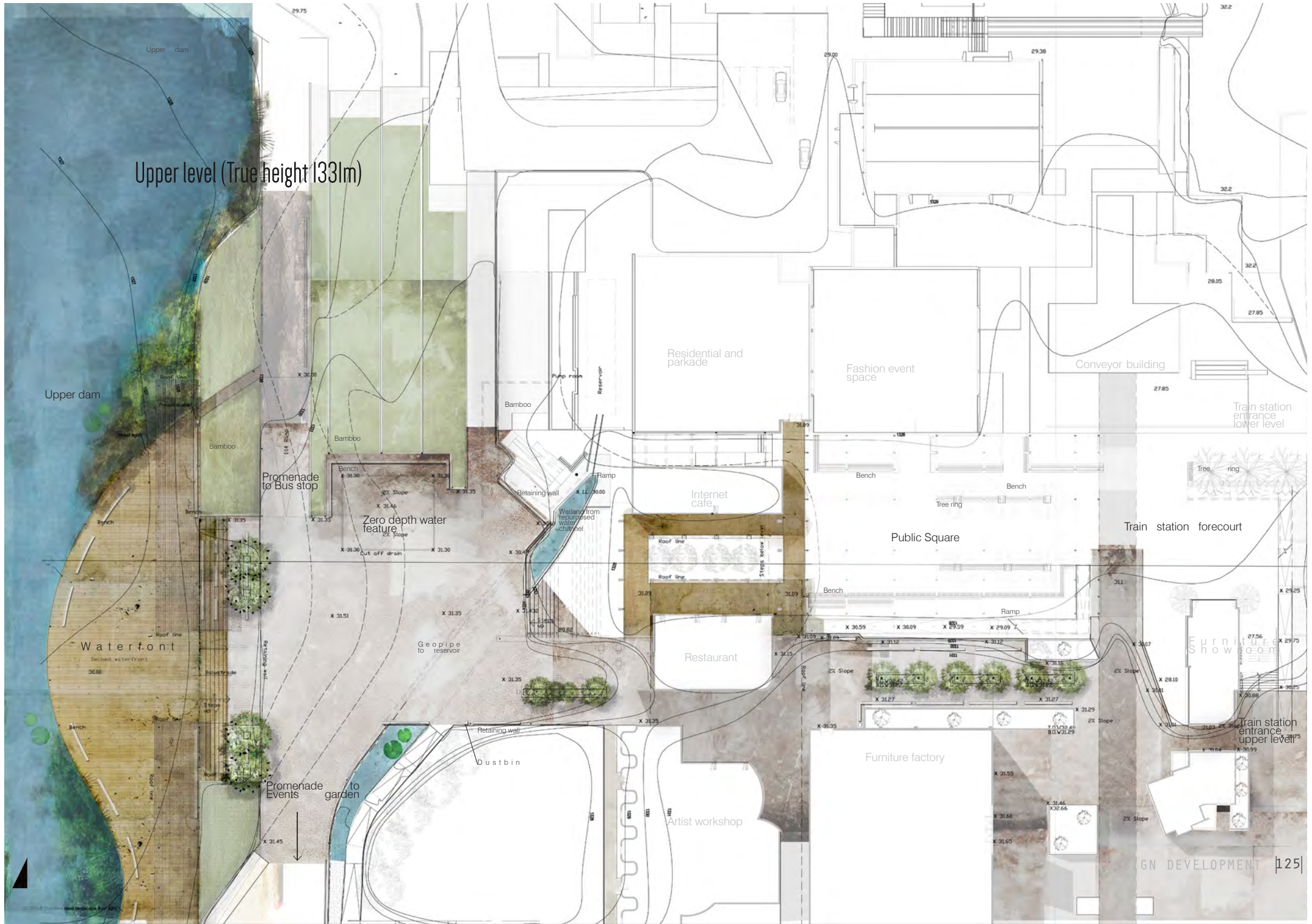

5.5.2 Sketch plan

Lower level (True height 1329m)

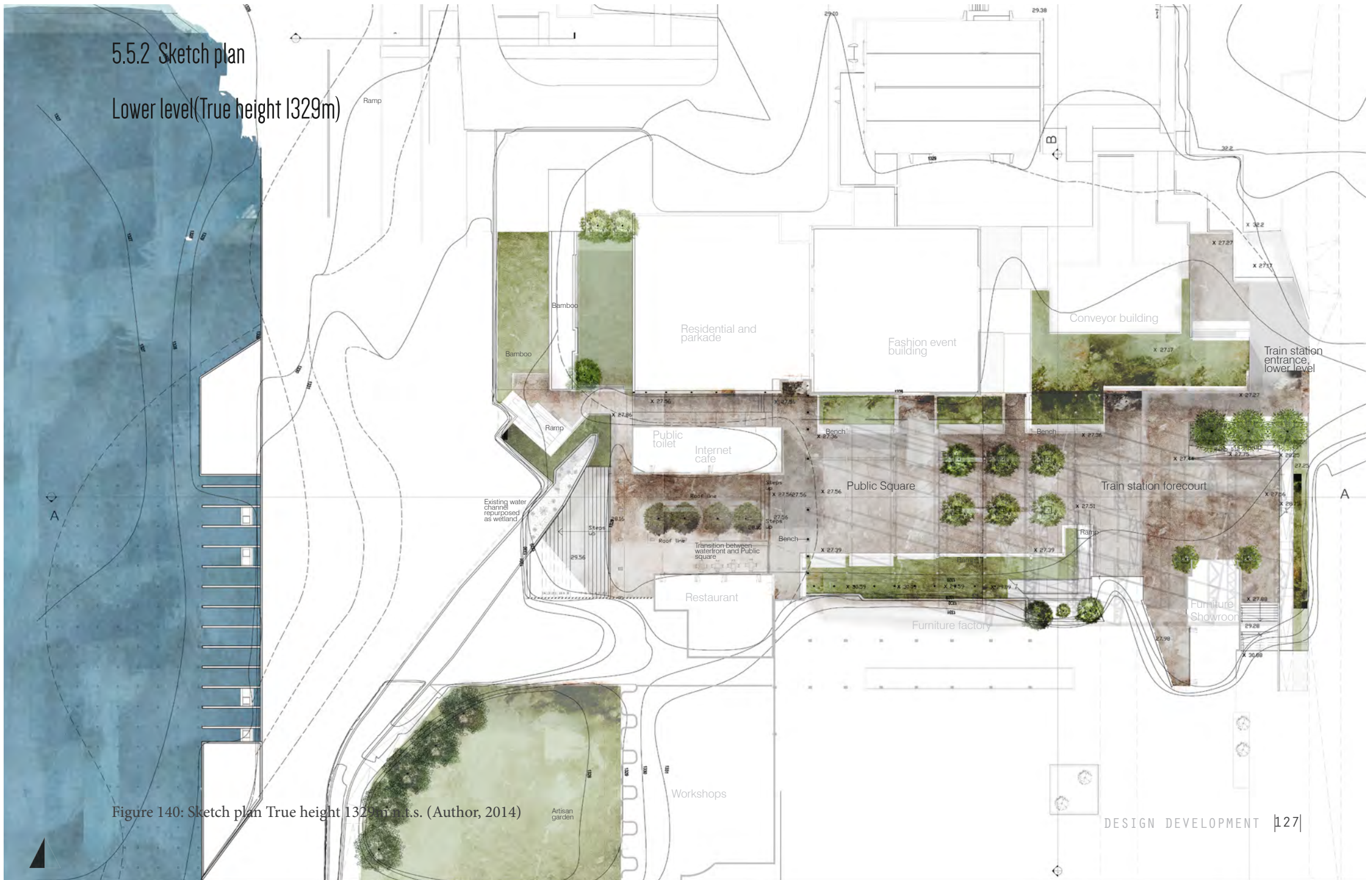

Figure 140: Sketch plan True height 1329 m n.t.s. (Author, 2014)

5.4.1 Spatial relationship diagram displaying concept intentions

Productions (cyclical in nature)

Linear movement through site

Public space

Biophilic elements

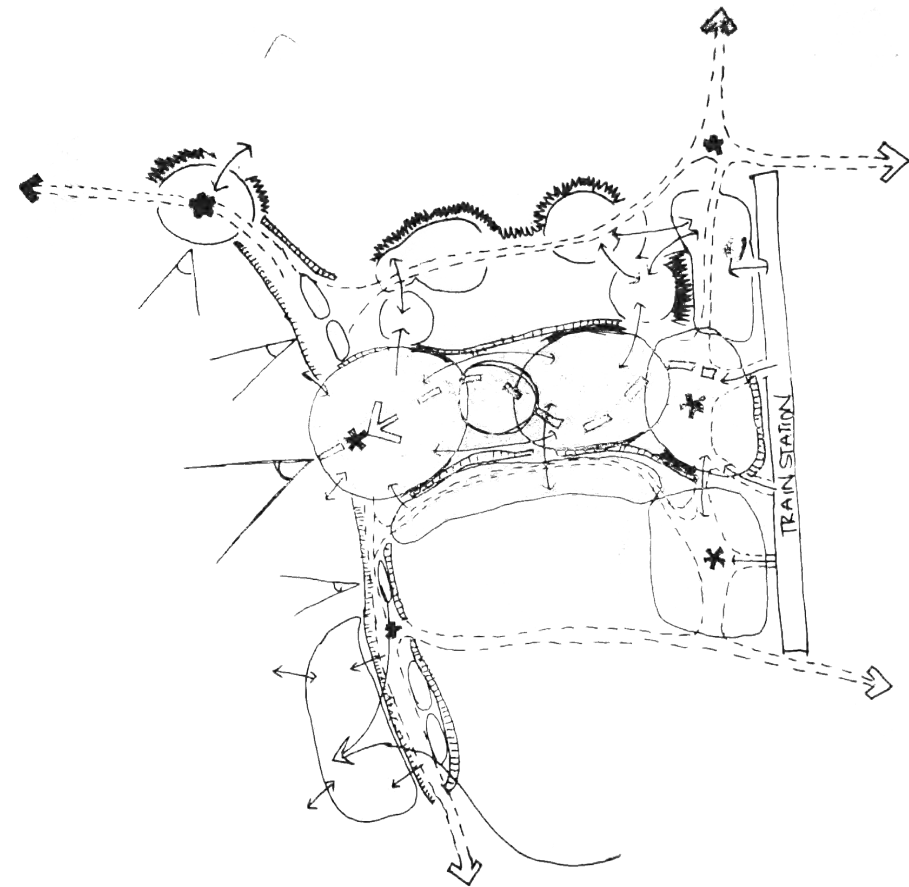

Figure 126: Spatial relationship diagram n.t.s(Author, 2014)

5.4.2 Design development

The spatial relationship diagram is translated into the context of the site, with iterations displaying the design intentions.

Square

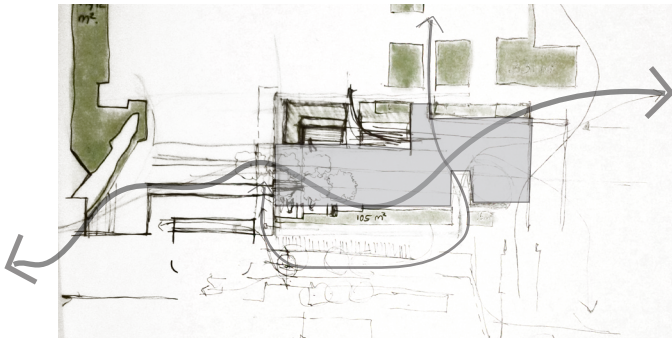

Figure 127: Accommodating the main movement through the site (Author, 2014)

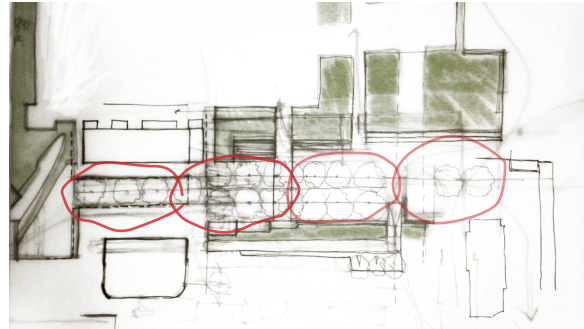

Figure 128: Creating a series of occupiable spaces. Which means creating seating, orientation points and shaded areas (Author, 2014)

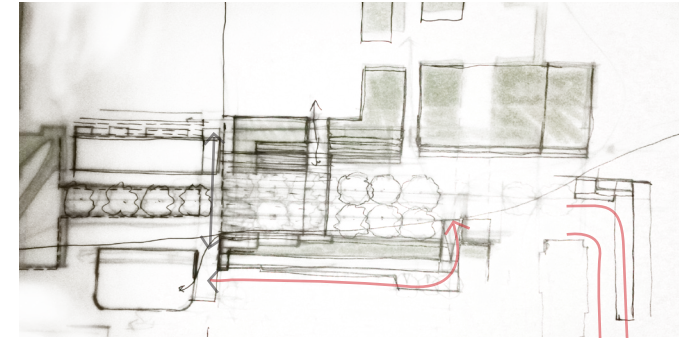

Figure 129: Connection to upper level (Author, 2014)

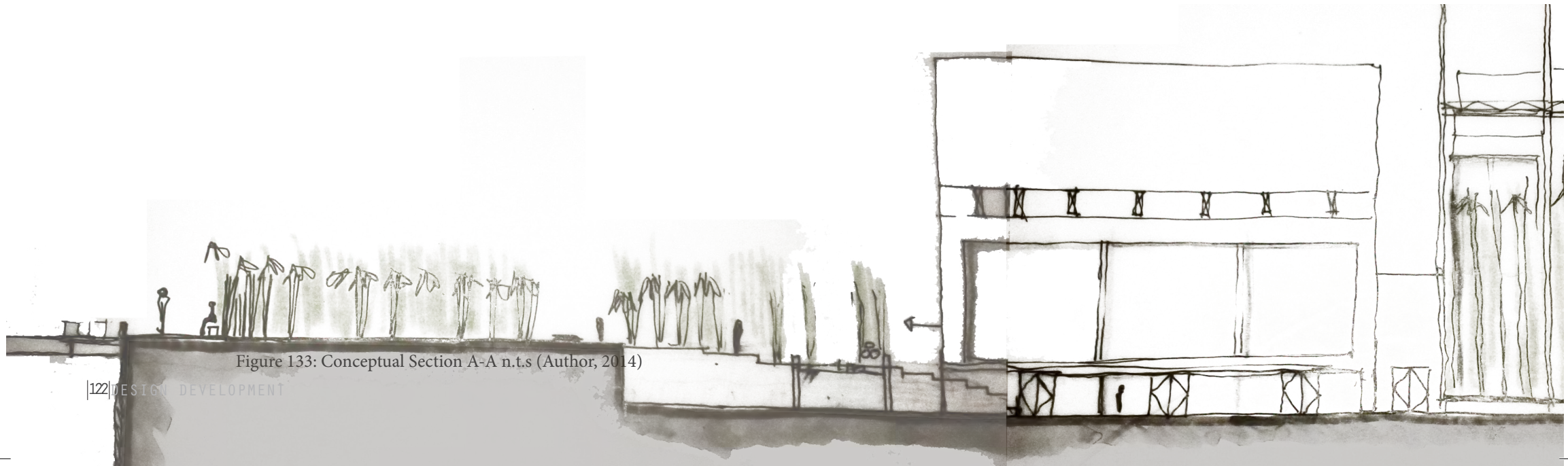

Figure 133: Conceptual Section A-A n.t.s (Author, 2014)

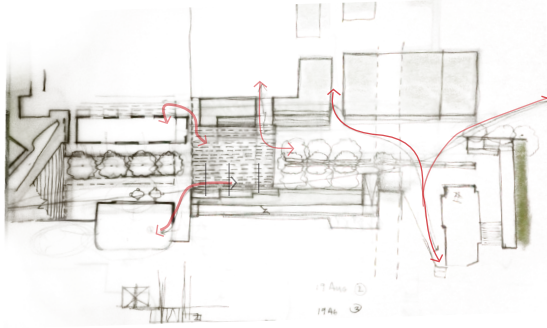

Figure 130: Accommodating entrances to buildings and viewing building functions (Author, 2014)

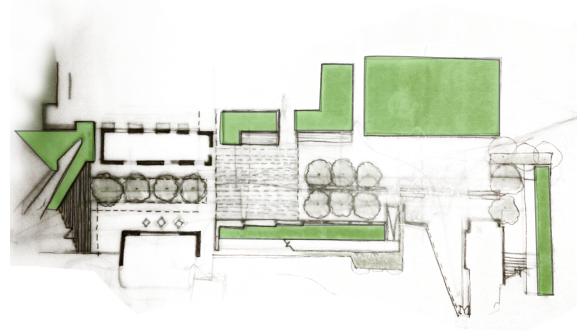

Figure 131: Public space shared with bamboo crop (Author, 2014)

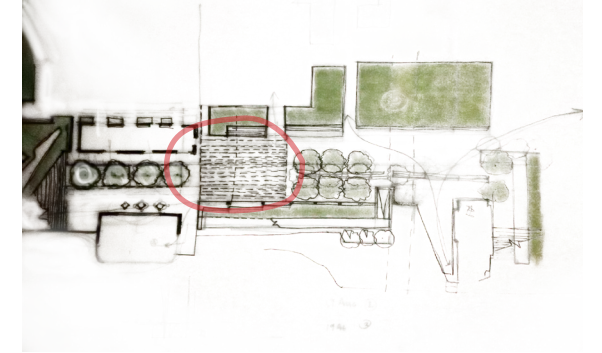

Figure 132: Proposed bamboo drying structure (overhead) (Author, 2014)

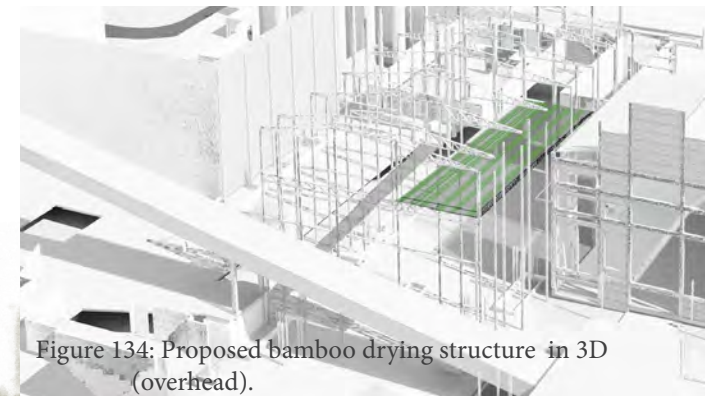
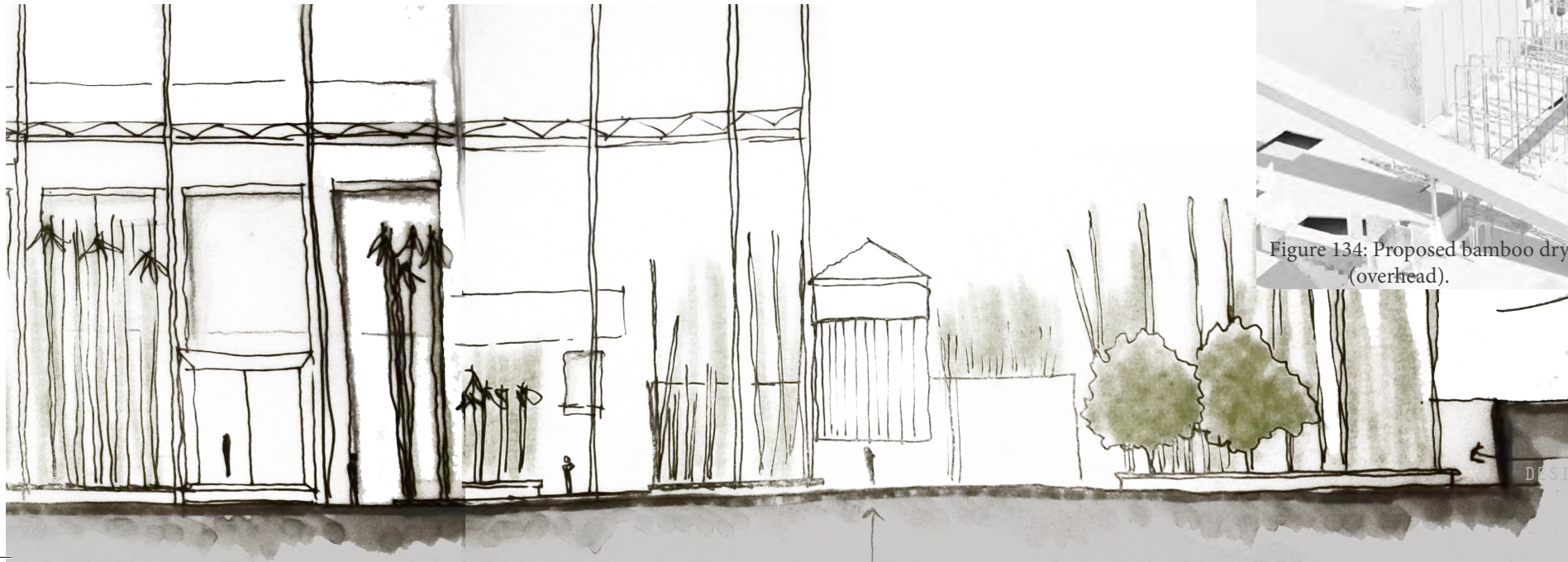

Figure 134: Proposed bamboo drying structure in 3D (overhead).

Waterfront

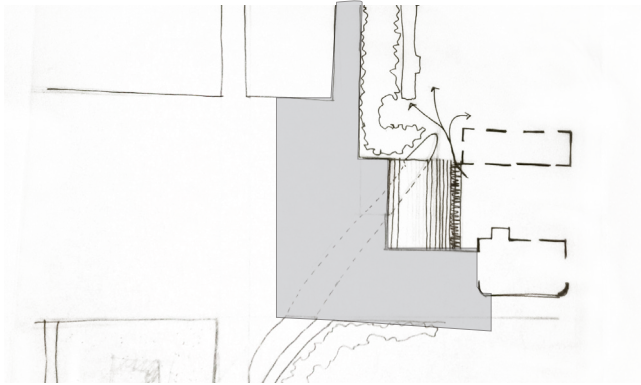

Figure 135: The channel is a constraint as it prohibits movement between square and waterfront (Author, 2014)

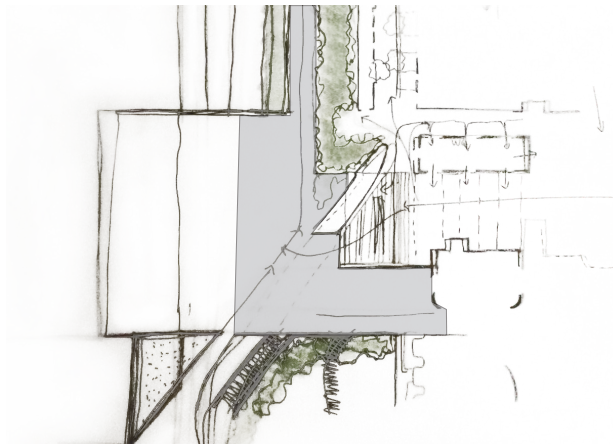

Figure 136: Steps are tapered according to the shape of the channel (Author, 2014)

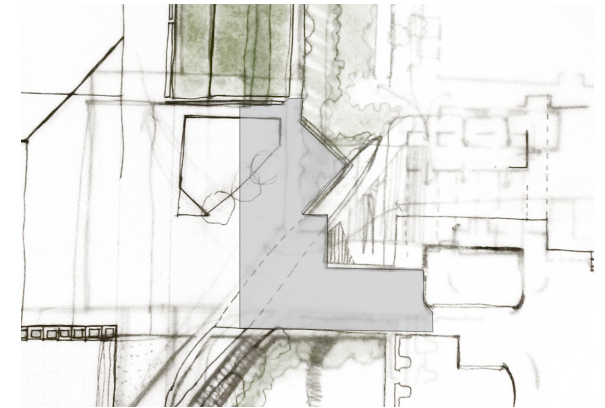

Figure 137: Zero depth water feature tapered according to the shape of the channel (Author, 2014)

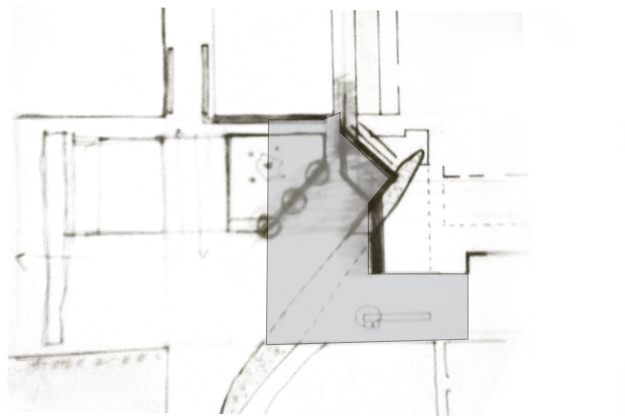

Figure 138: The channel is a constraint as it prohibits movement between square and waterfront (Author, 2014)

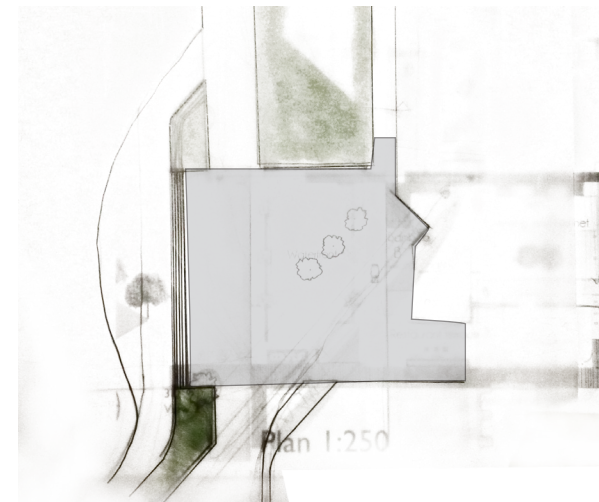

Figure 139: Organic waterfront edge is more appropriate as a transitional space between the events park and the square. (Author, 2014)

5.5.2 Sketch plan

Lower level (True height 1329m)

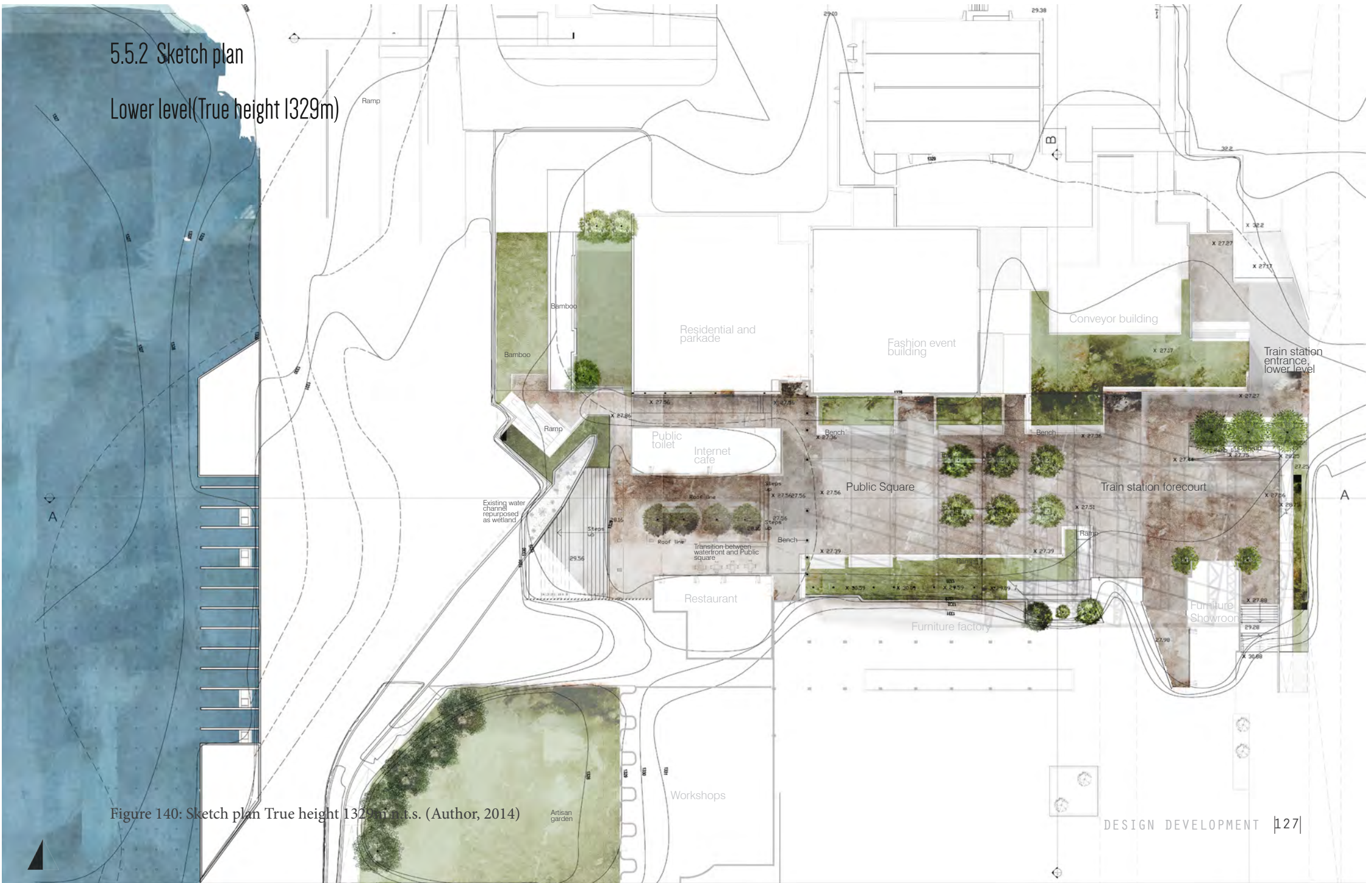

Figure 140: Sketch plan True height 1329 m m.t.s. (Author, 2014)

5.5.3 Spatial sections through site

Section A-A nts



Figure 141: Sketch plan section AA. (Author, 2014)

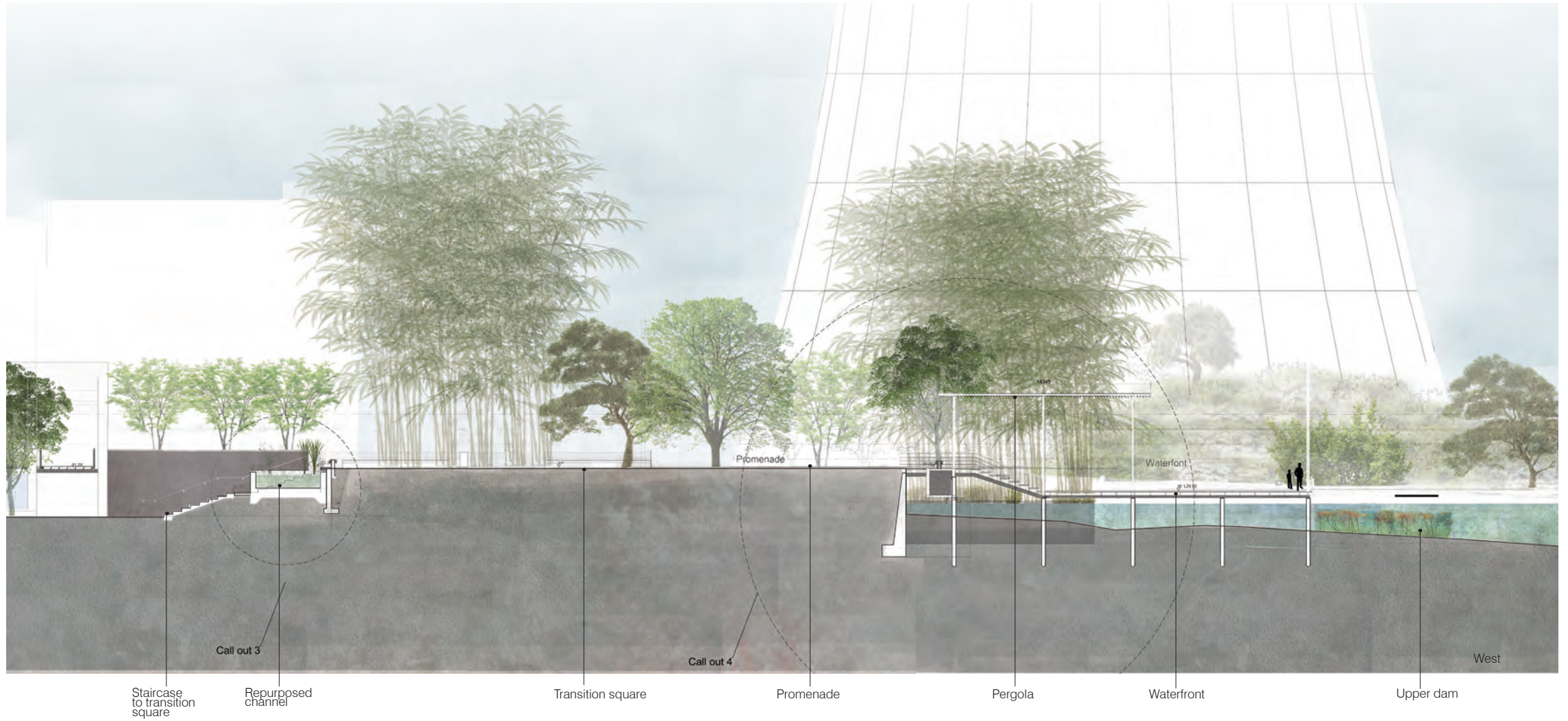

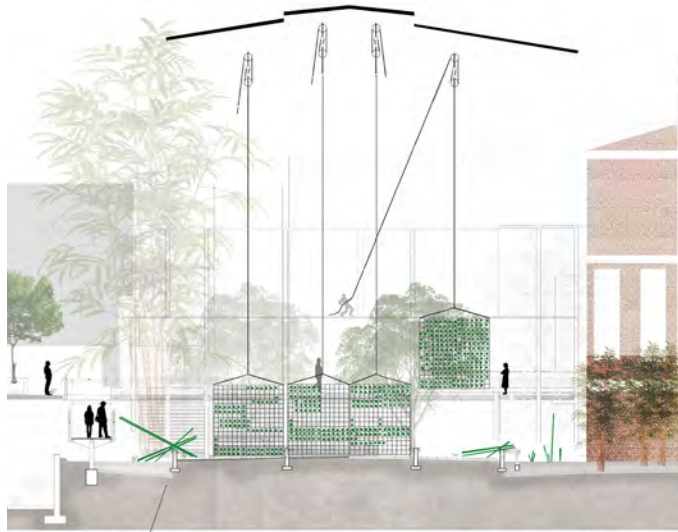

Figure 142: August Bamboo harvest (Author, 2014)

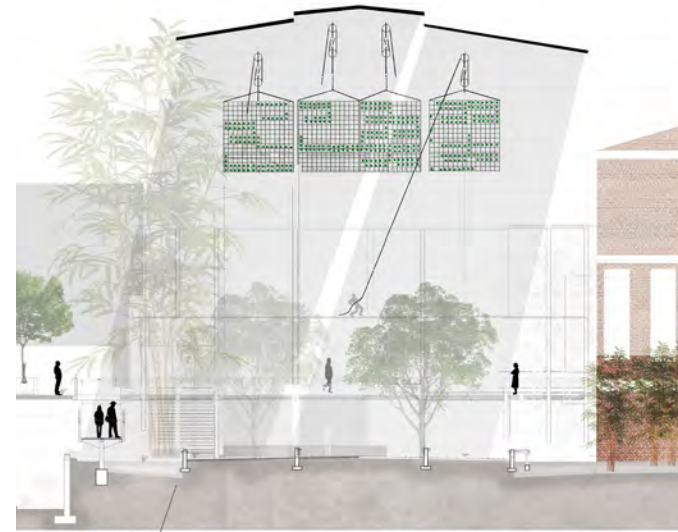

Figure 143: August- November drying, closed shutters (Author, 2014)

Biophilic
User perception

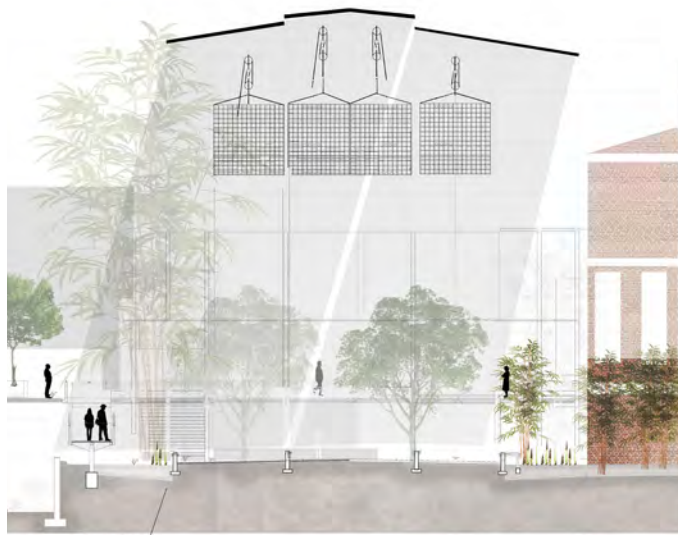

Figure 144: November - February Shutters closed according to user need and new culm growth (Author, 2014)

Biophilic
User perception

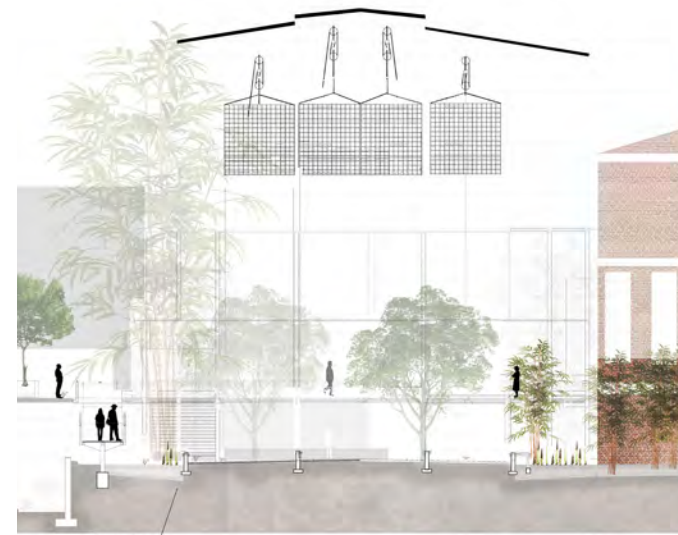

Figure 145: February -August open shutters (Author, 2014)



Figure 146: Perspective view of Square, Looking West (Author, 2014)

Figure 147: Section B-B n.t.s (Author, 2014)





Deli

Clothing factory

Clothing factory
spill out space

Charlotte Maxeke

DESIGN DEVELOPMENT | 131 |

6. TECHNICAL INVESTIGATION



Figure 148: : Man part of space through peripheral vision and perception (Author, 2014)



Figure 149: User encapsulated in space to address approach (Author, 2014)



Figure 150: Transparency of productions for educational value and user comfort in an intimidating urban environment (Author, 2014)

6.1 Introduction

The technical chapter is informed by the intentions set out in the conceptual phase of the dissertation. The intentions are to make man feel part of the space, to instil meaning in the user through peripheral vision and to create a feeling of encapsulation in the user. One intention is to educate the user, therefore applicable transparency in materiality is required.

6.1.1 Chapter division

The chapter is divided into 4:

1. A space for humans,
2. A space for production
3. A space for nature
4. Site sustainability rating

6.2 Technical concept

The technical concept is an extension of the concept of providing a landscape with the possibility of different interactions between man nature and productions. The proposed types of interactions are illustrated in figure 148, 149 and 150. A collective vision of the interactions is seen in figure 151.

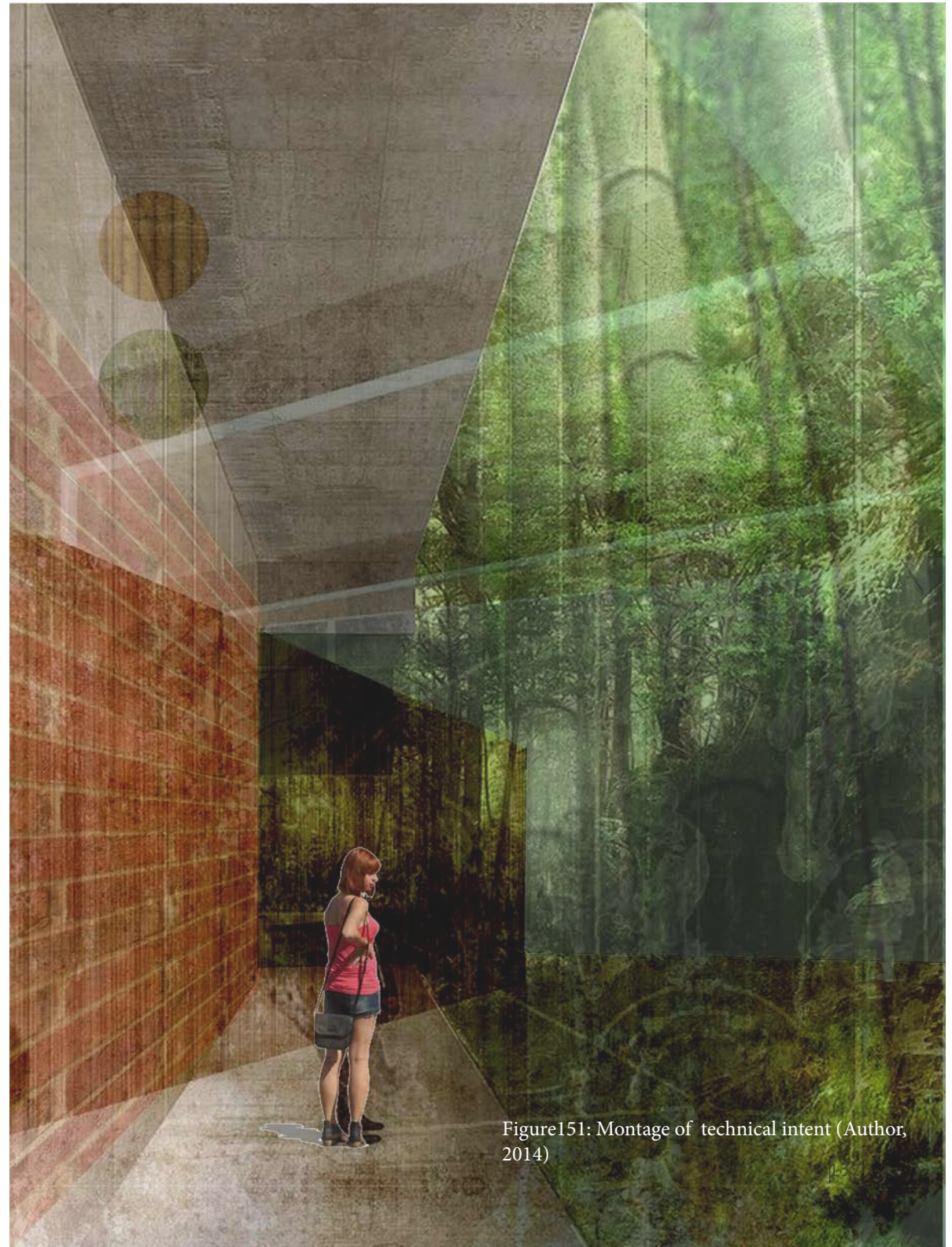

Figure151: Montage of technical intent (Author, 2014)

6.3 Space for humans

6.3.1 Human comfort: Sun study

6.3.1.1 Analysis

The industrial history of the site means that the scale of the building and open spaces create harsh outside environments. A sun study was conducted through Autodesk Revit modeling to inform technical design decisions that enhance the user comfort of the public spaces.

Sun study process towards a design response:

1. Conducted a shadow study of the sketch plan area for 8am, Noon and 4pm on the equinoxes and solstices throughout the year visible in figure 152.

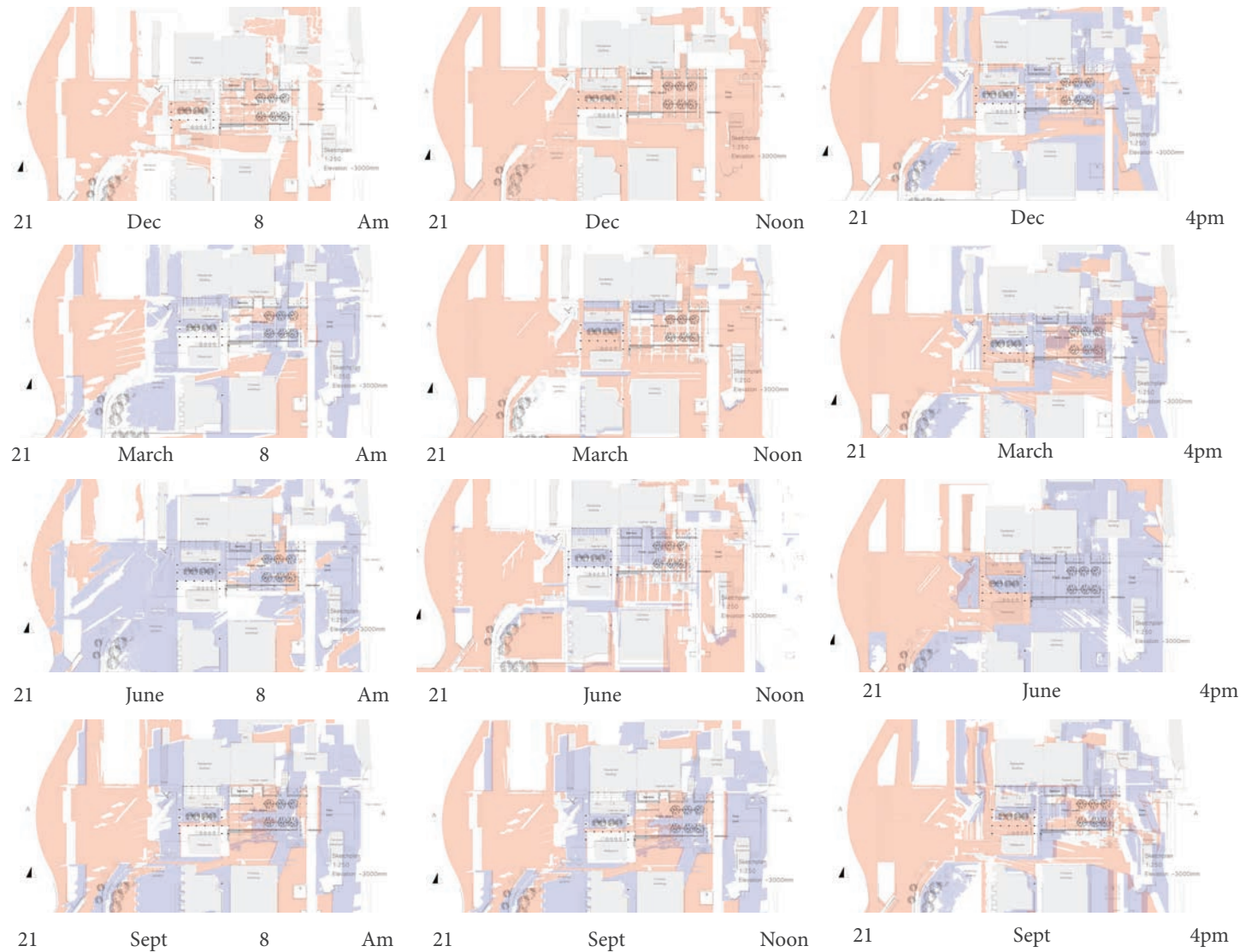

Figure 152 : Base line Shadow study of the sketchplan area (Author, 2014)

2. The shadows in the conducted sun study are layered in figure 153 to indicate areas which are mostly shaded throughout the year. These areas are expected to be cool throughout the year.

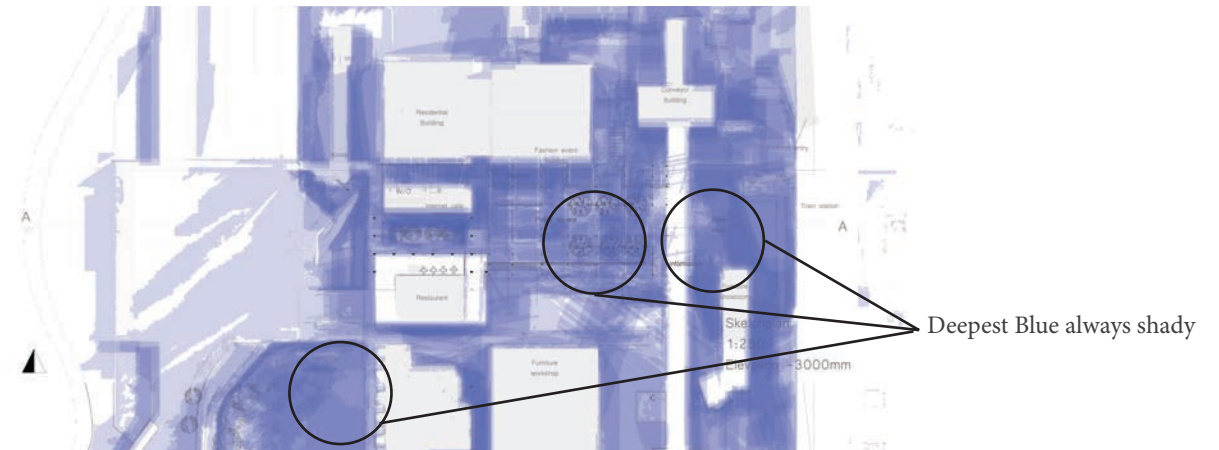

Figure 153: Layered shadows on the site. deepest blue indicating mostly shaded areas (Author, 2014)

3. The areas exposed to the most sun are layered in figure 154 to indicate areas most exposed to sunlight, which will most likely be uncomfortable areas. Landscape architecture interventions can respond appropriately to these conditions.

The layered responses in a general indicate the hot and cool areas on site.



Figure 154: Layered sun areas. Deepest red are areas most exposed to sun throughout the year (Author, 2014).

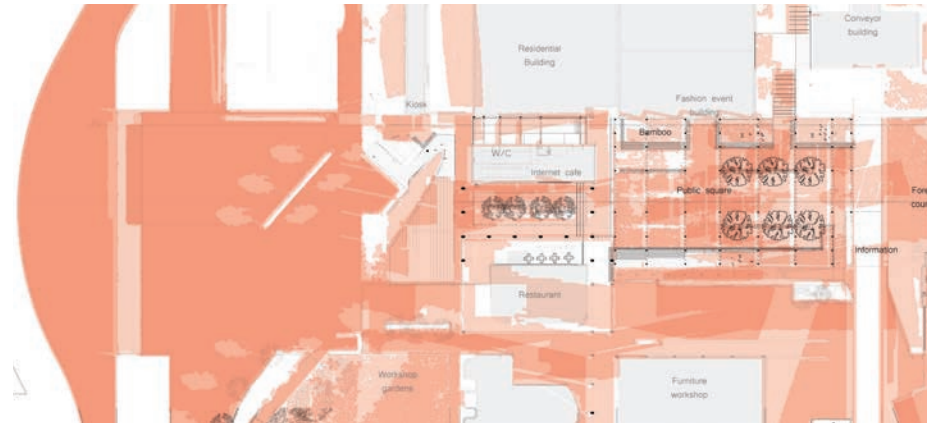

Figure 155: Summer hottest areas (Author, 2014)

4. Figure 155 displays areas exposed during the three time frames of the summer solstice are layered to indicate the hottest most uncomfortable areas in summer months.

5. Winter solstice, shady areas are layered to indicate the coldest areas on the sketchplan. As seen in figure 156.

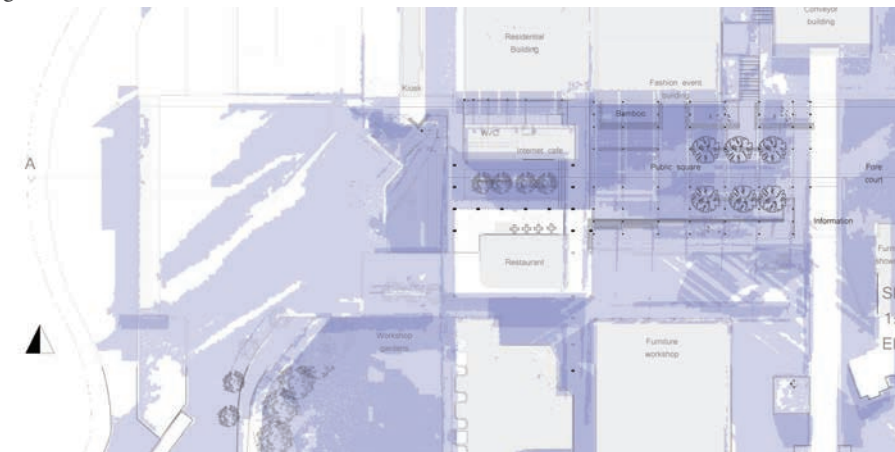

Figure 156: Winter, coolest areas (Author, 2014)

The overlapping of the two extreme areas calls for a changeable design intervention that allows for sun in the summer and shade in the winter. The overlapping areas can be seen in figure 157.

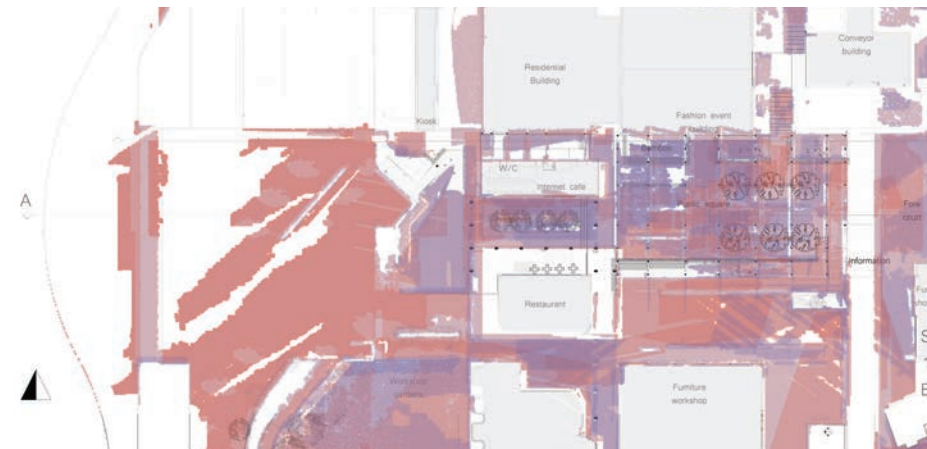

Figure 157: Where the areas overlap changeable design intervention is required (Author, 2014)

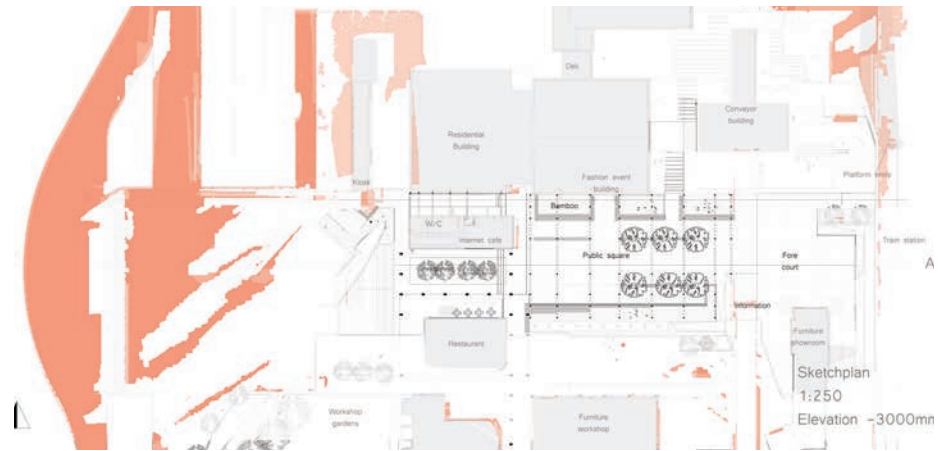

Figure 158: Areas requiring permanent shade structures. (Author, 2014)

Permanent sunny areas, as indicated in figure 158 will partially require permanent shade structures:

Only the most significant areas on the sketch plan are proposed to be shaded for human comfort as indicated in figure 159.

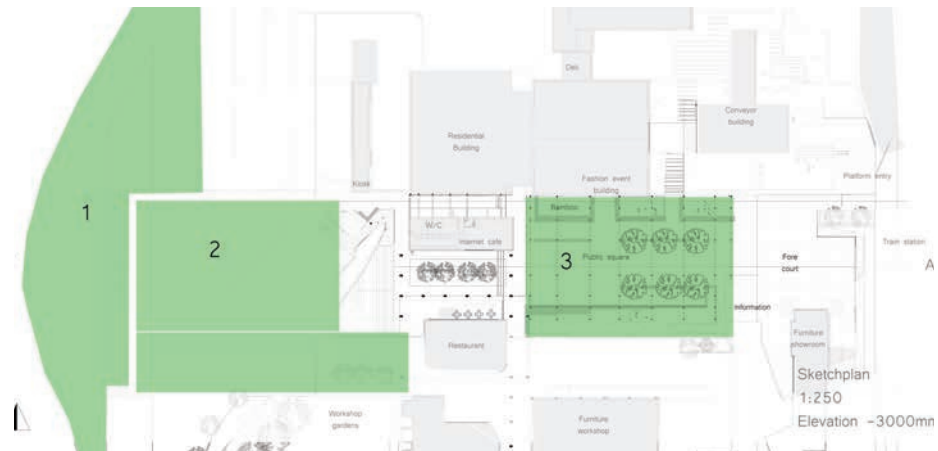

Figure 159: Areas crucial for human comfort. (Author, 2014)

6.3.1.2 Sunstudy strategy

The following is a conceptual shade devices is informed by the sunstudy conducted in the previous section, specifically relating to the areas crucial for human comfort.

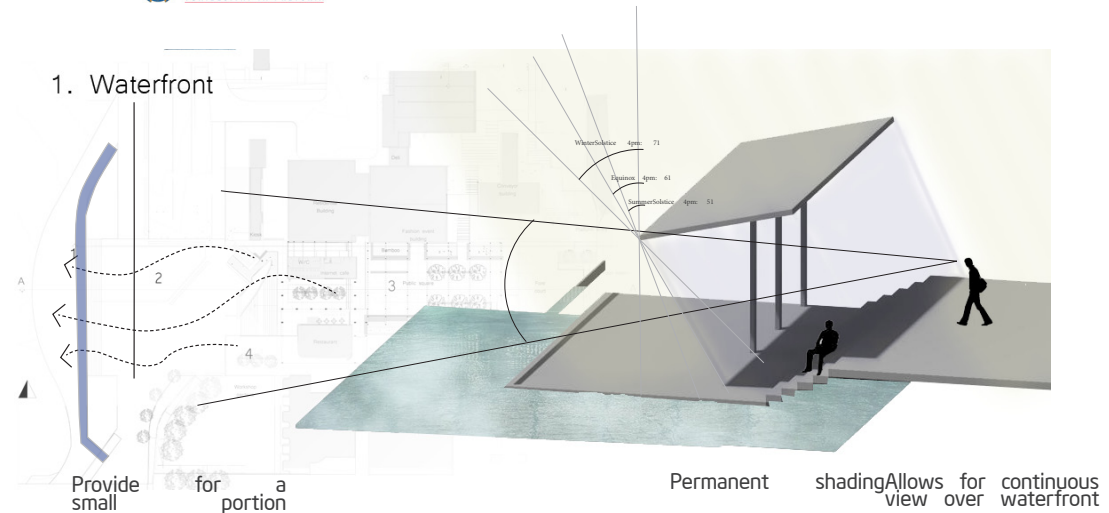

Figure 160: Waterfront shade concept (Author, 2014)

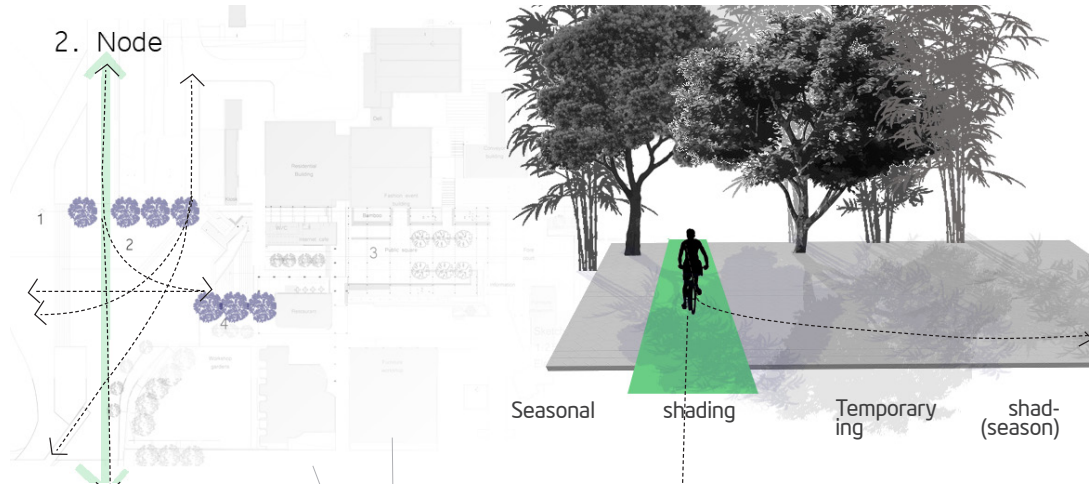

Figure 161: Node shade concept (Author, 2014)

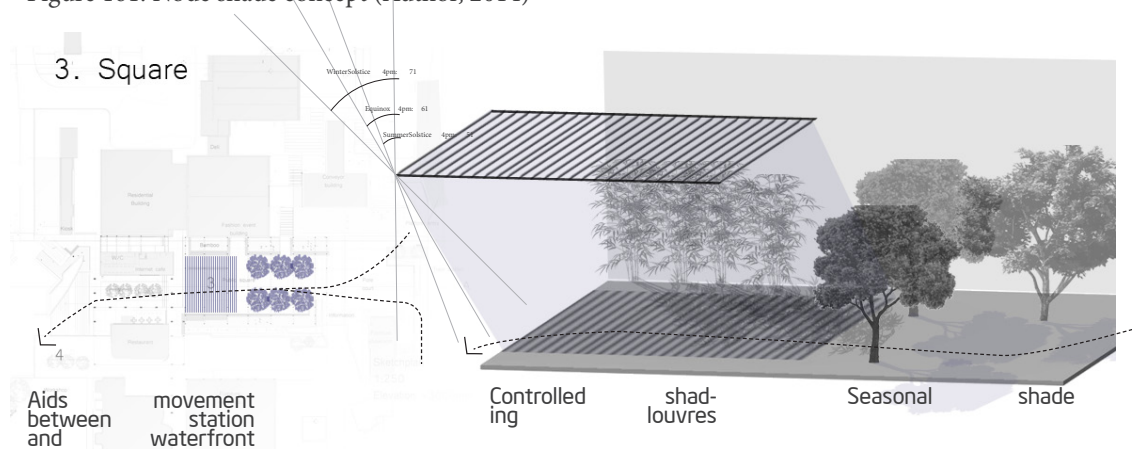

Figure 162: Square shading concept (Author, 2014)

6.3.1.2 Sun study application

6.3.1.2.1 Waterfront, Pergola construction

The size of the pergola relates to its context in in materiality and in size. The bamboo purlins are in contrast with the steel structure.

6.3.1.2.1 Node, deciduous trees

Planting strategy is discussed in the third portion of this chapter, space for nature.

6.3.1.2.2 Square, controlled shading louvers

The square's shading strategy is shown in the second portion of this chapter, space for production, as it forms a part of the drying of the bamboo.

6.3.2 Lighting design

6.3.2.1 Lighting design strategy

Solar lighting is proposed in all the sections mentioned below

Operational lighting

Operational lighting refers to the minimum lighting required for the site to function as proposed during the

night. Thus, the Public Square, waterfront, promenade, nodes and site entrances are all well lit. Operational lighting is indicated in figure 163.

Aesthetical lighting

Aesthetical lighting refers to the highlighting of certain aspects within the landscape. Aesthetical lighting includes bollard lighting, floor lights, lighting placed in bamboo and lighting on level changes.

Emergency lighting

Public spaces such as the train station platform exits, mix used entrances, promenade and square have minimum lighting, in case of a power outage or other emergencies. Exits and entrances to the site

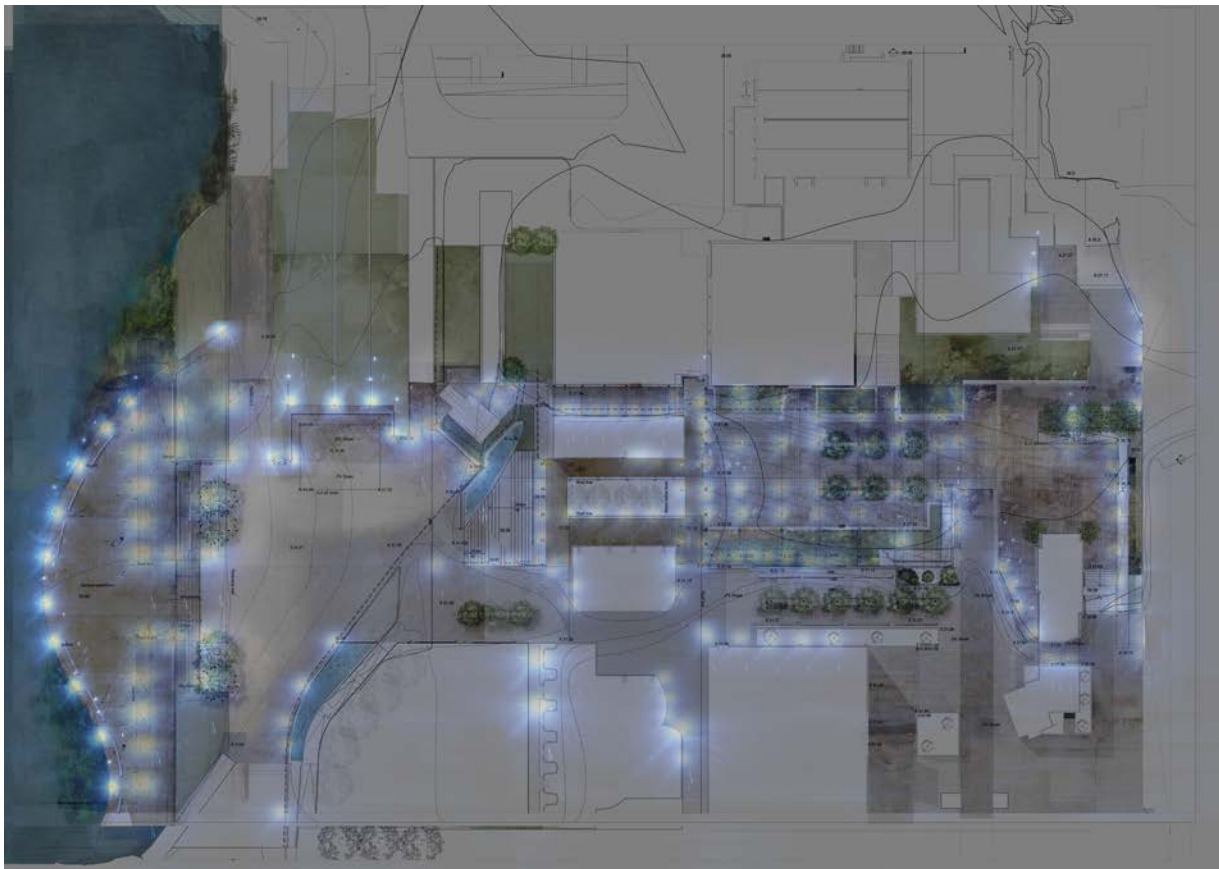

Figure 163: Operational Lighting (Author, 2014)



Figure 164: Aesthetical Lighting (Author, 2014)

are well lit, floor light requiring minimum electricity is kept on for the users to find their way to the exists

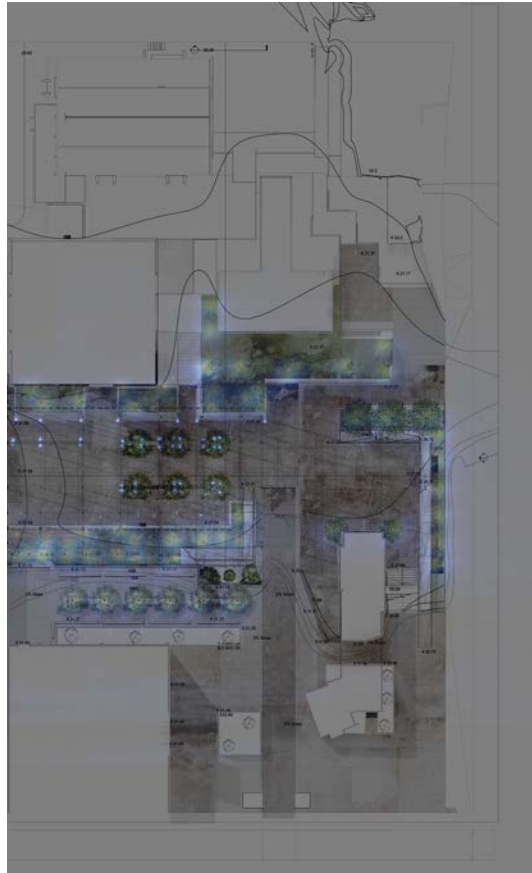

Figure 165: Emergency Lighting (Author, 2014)

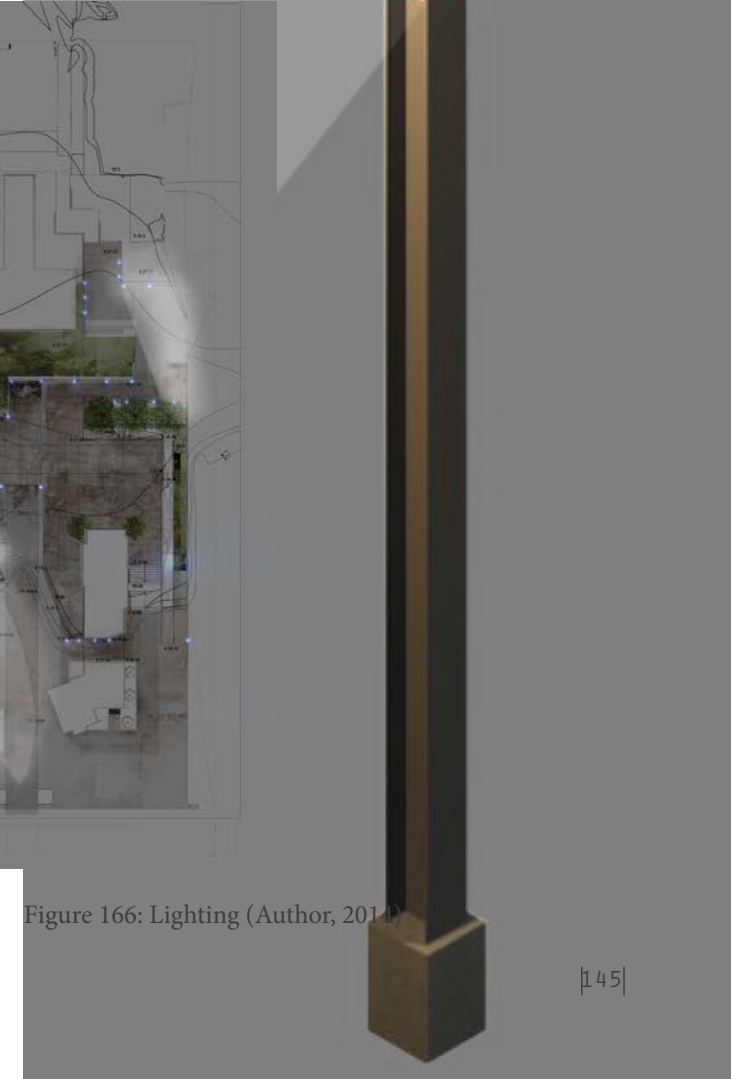
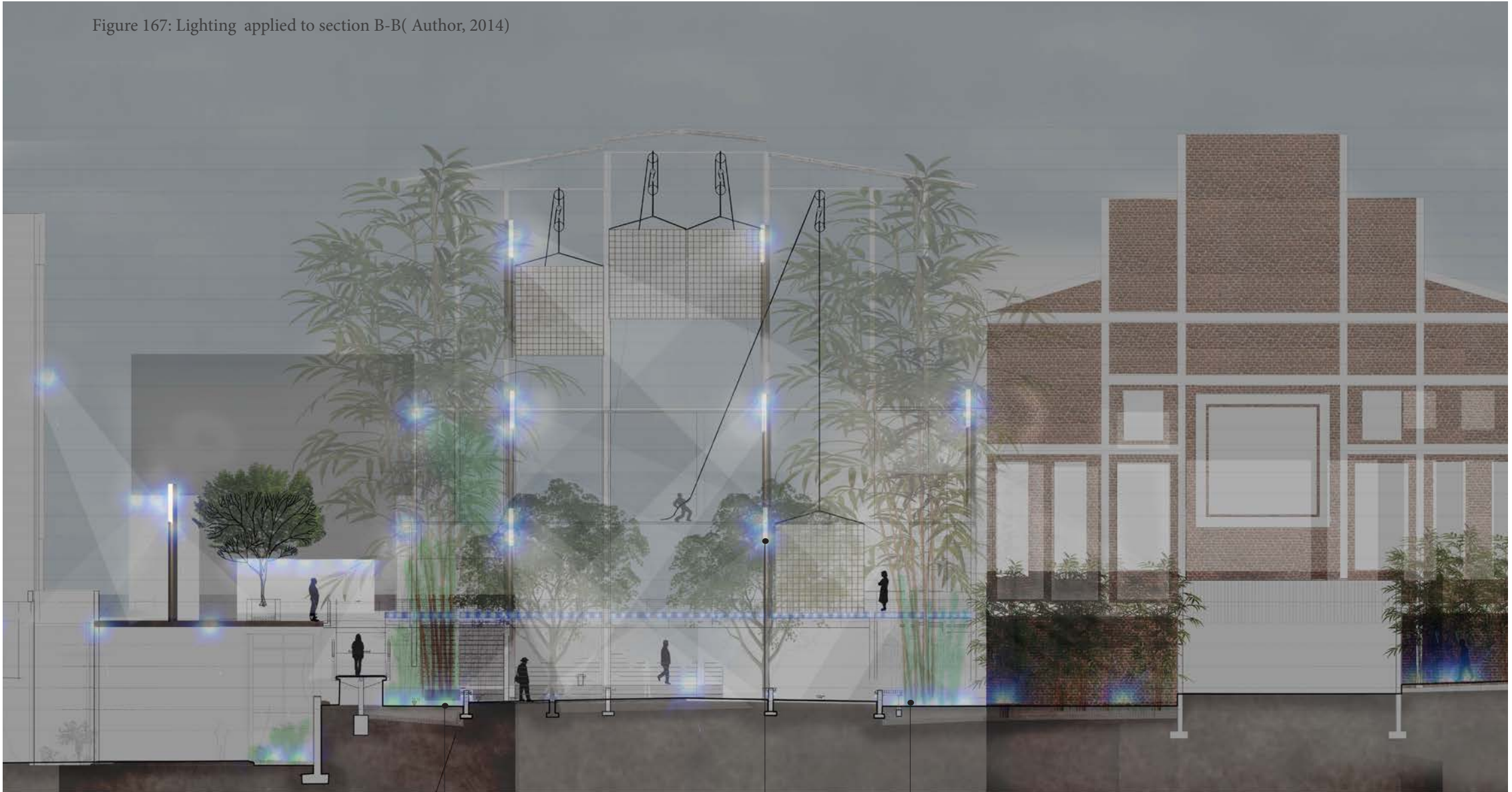

Figure 166: Lighting (Author, 2014)

Lighting applied to section B-B

Figure 167: Lighting applied to section B-B(Author, 2014)



Landscape lighting in bamboo planting beds

Lighting in existing structure

Landscape lights in bamboo planting beds

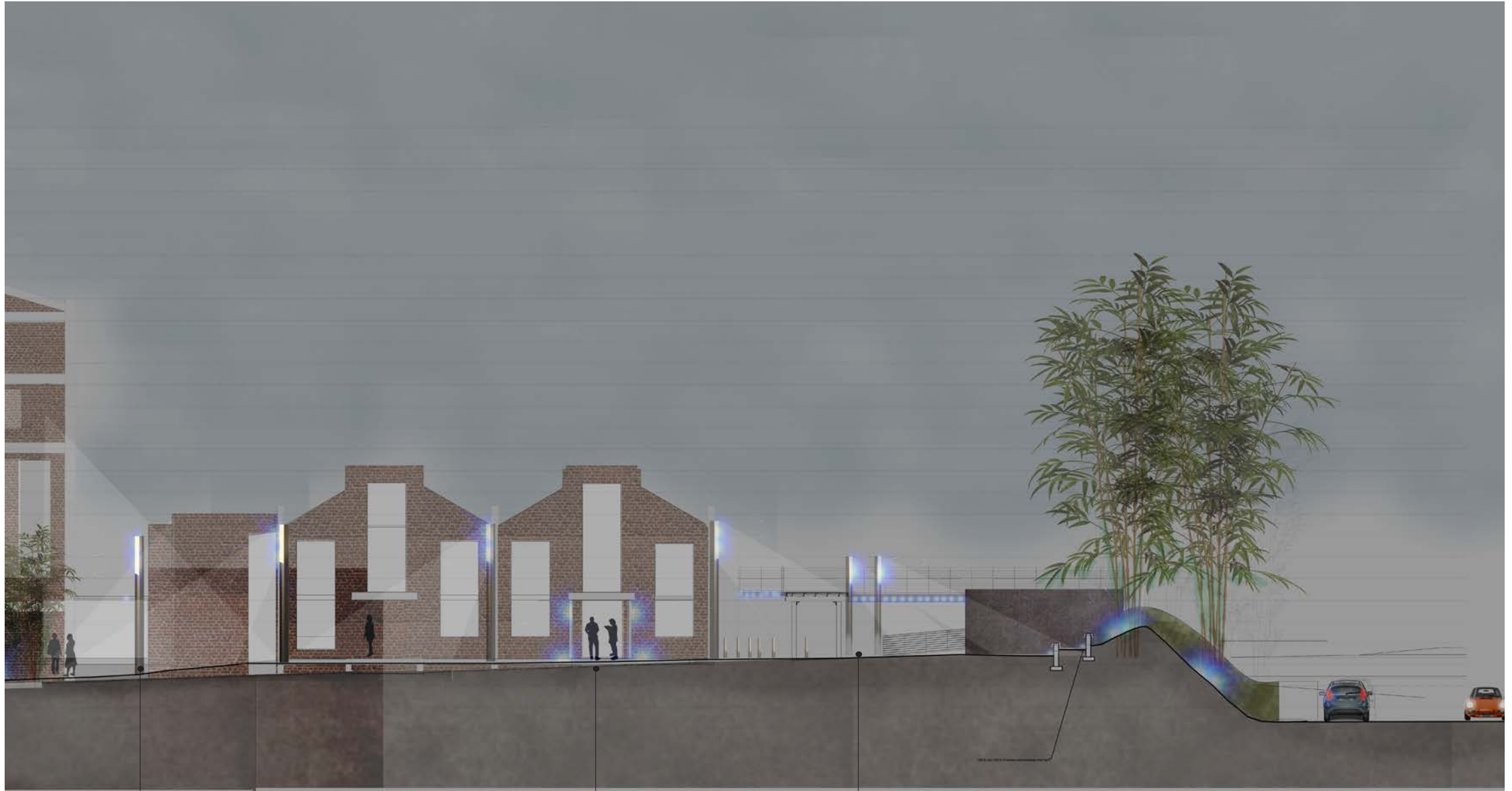

Street lights

Lit entrance

Lights are adjustable to accommodate outdoor events

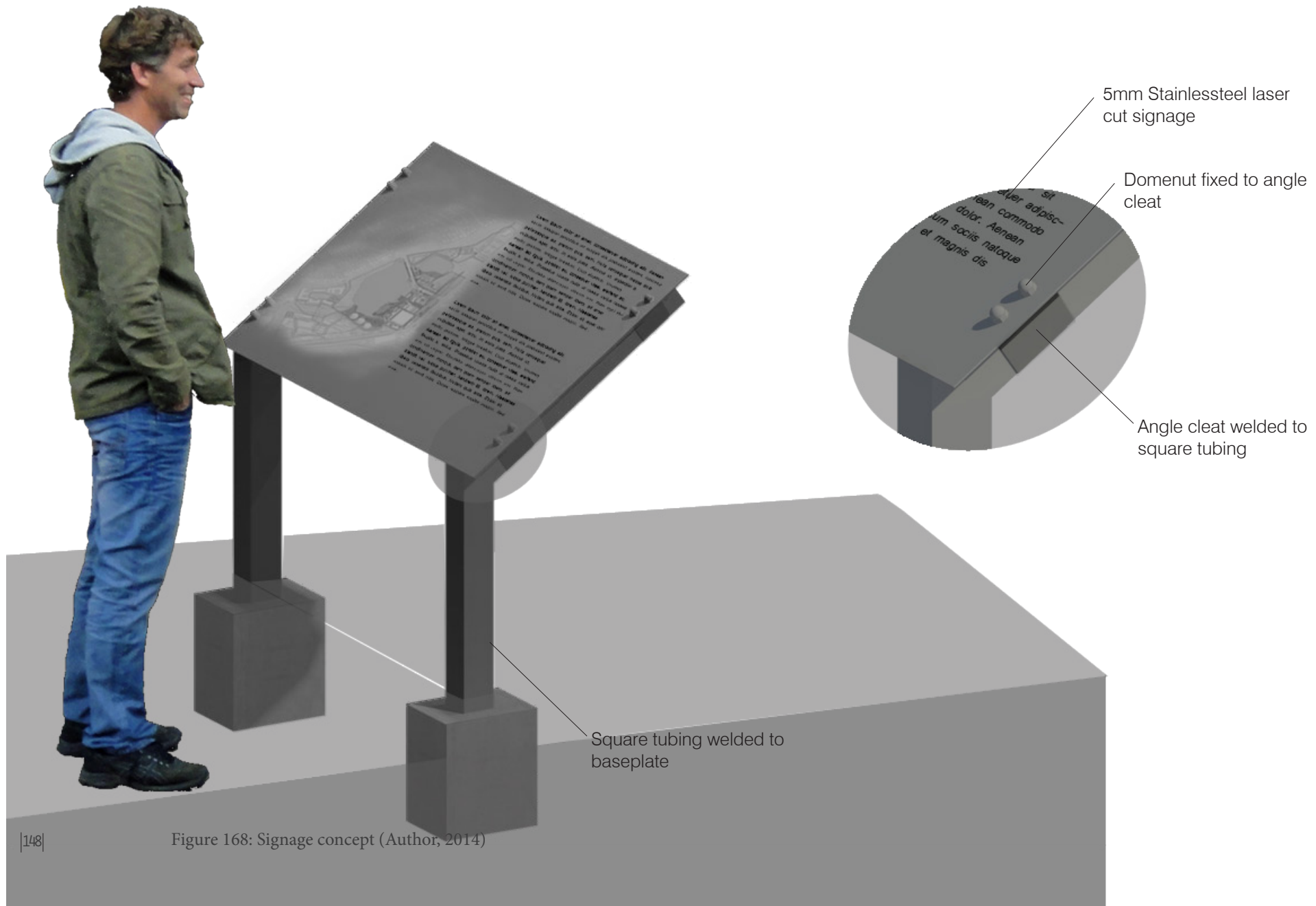

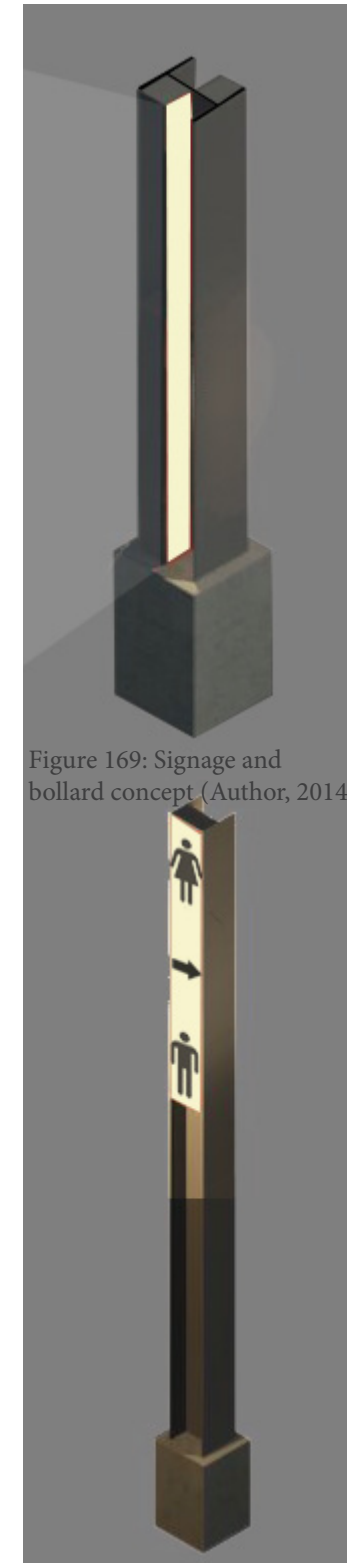
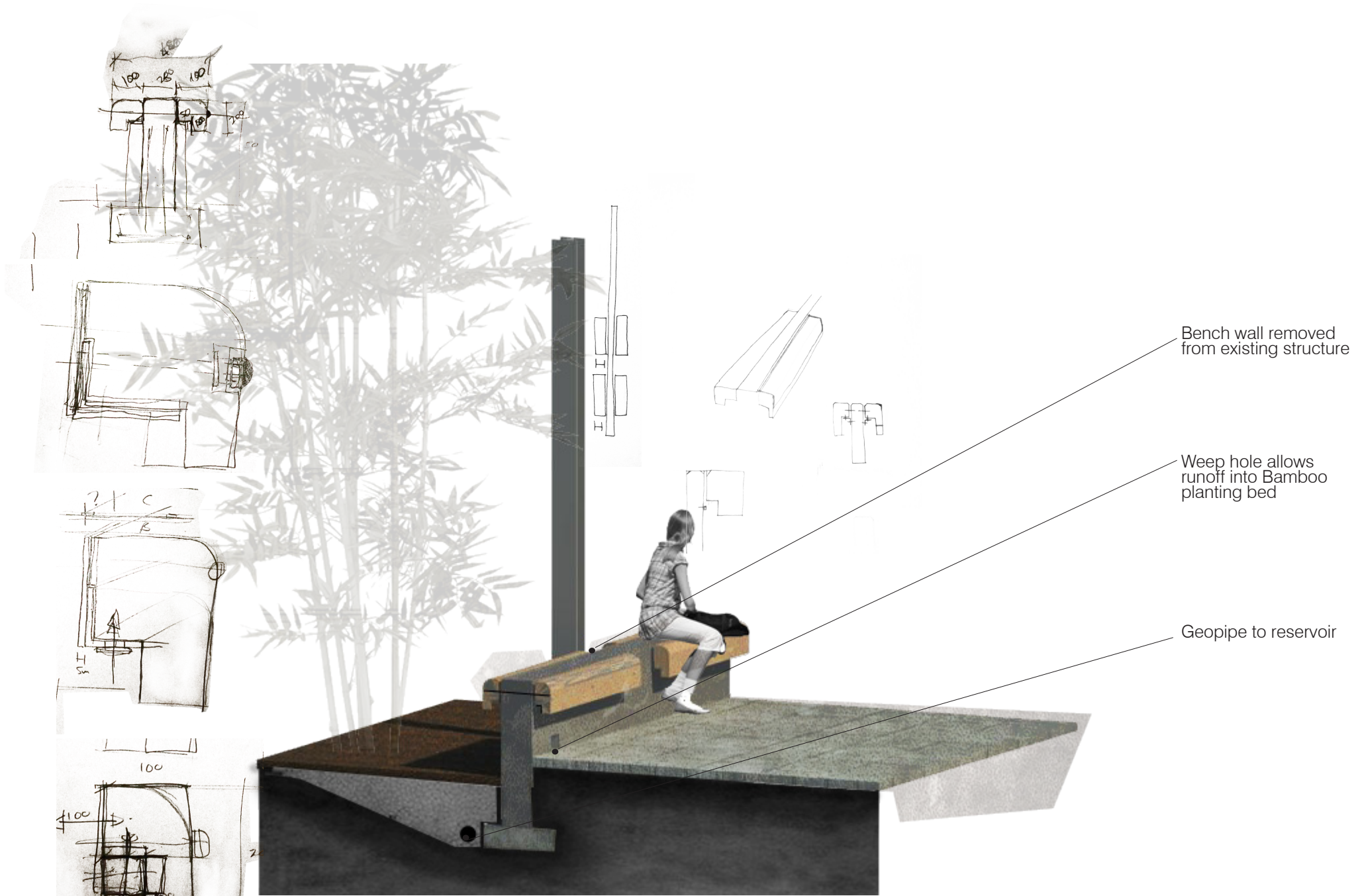

Figure 169: Signage and bollard concept (Author, 2014)



Bench wall removed from existing structure

Weep hole allows runoff into Bamboo planting bed

Geopipe to reservoir

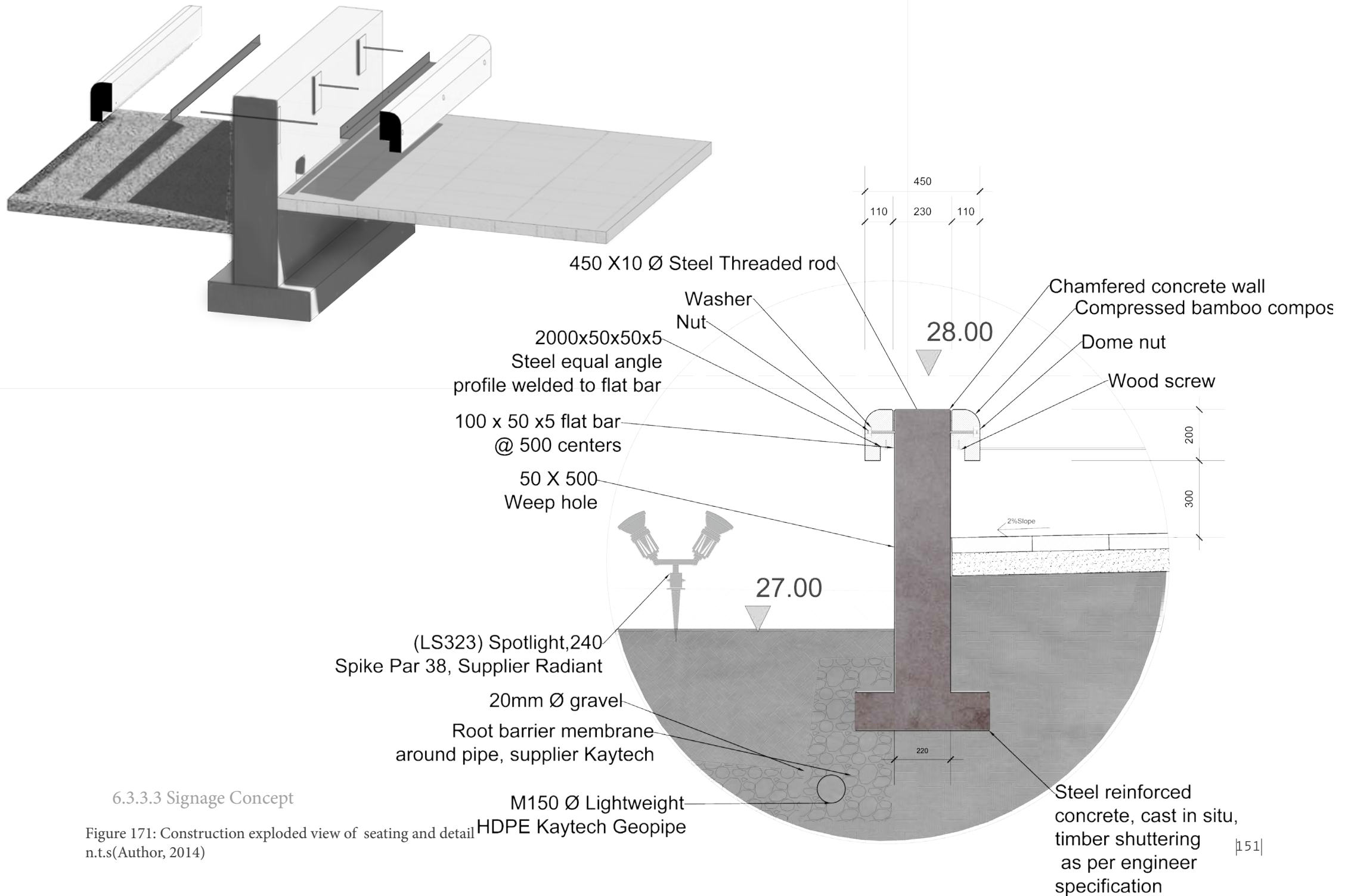

6.3.3.3 Signage Concept

Figure 171: Construction exploded view of seating and detail
n.t.s(Author, 2014)

6.4 Space for production

The productions resolved technically is the water management and the bamboo planting, harvesting and drying. The mentioned processes are incorporated into the sketch plan design for maximum exposure to the user.

6.4.1 Site hydrology and hydraulic structures

6.5.1.1 Water harvesting/source and water use and budgets

The assumption is made that water that was pumped from Daspoort waste water treatment facility will no longer be pumped as it will be used in areas of higher demand. Water shed is determined around the site to alleviate the water demand from the site and to maintain the existing water body. The objective of the water strategy is

to keep the top dam to capacity and ensure that the water demands of the site are met. The complete water budget can be seen in appendix 8.1. The watershed and water strategy is displayed in figure 172 and 173 will supply water to the main dam. During the summer rains, the top dam will overflow and water will be diverted into the bottom dam. Irrigation for the southern side of the site will be pumped from the main dam. Irrigation for the northern side of the site will be pumped from the bottom dam.

Activities proposed for the main dam requires it to be kept at its full capacity. During the year, water will be pumped from the bottom dam to the main dam to ensure a constant water level. The water required to do so is thus included in the budget for the bottom dam.

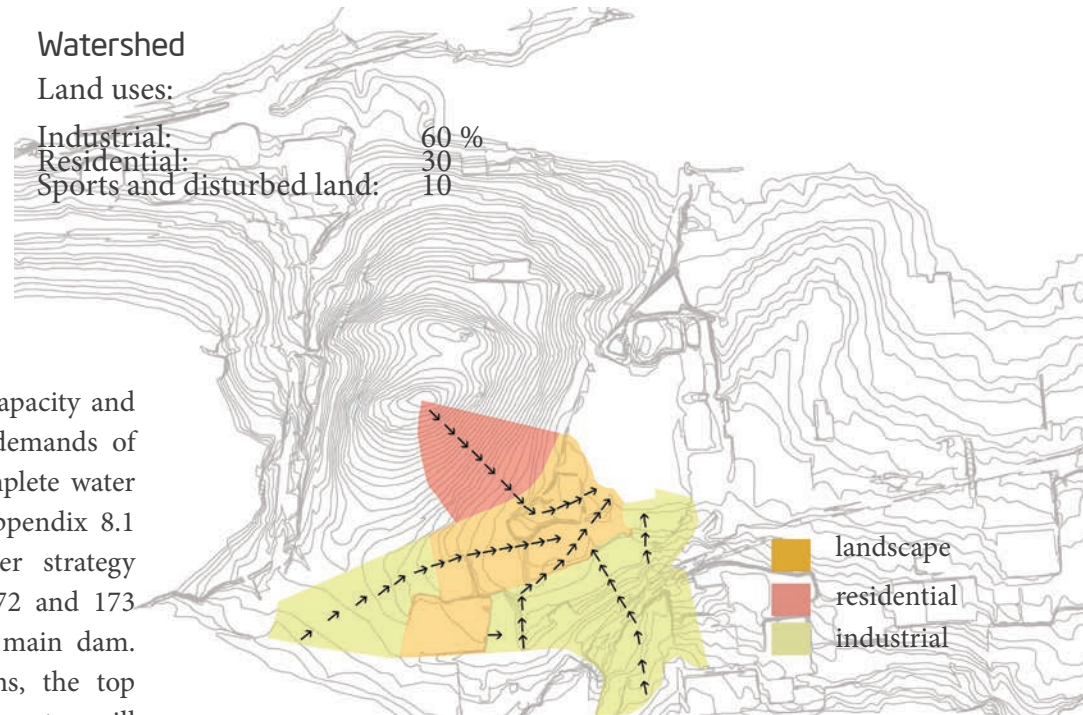

Figure 172: Different land uses on watershed (Author, 2014)

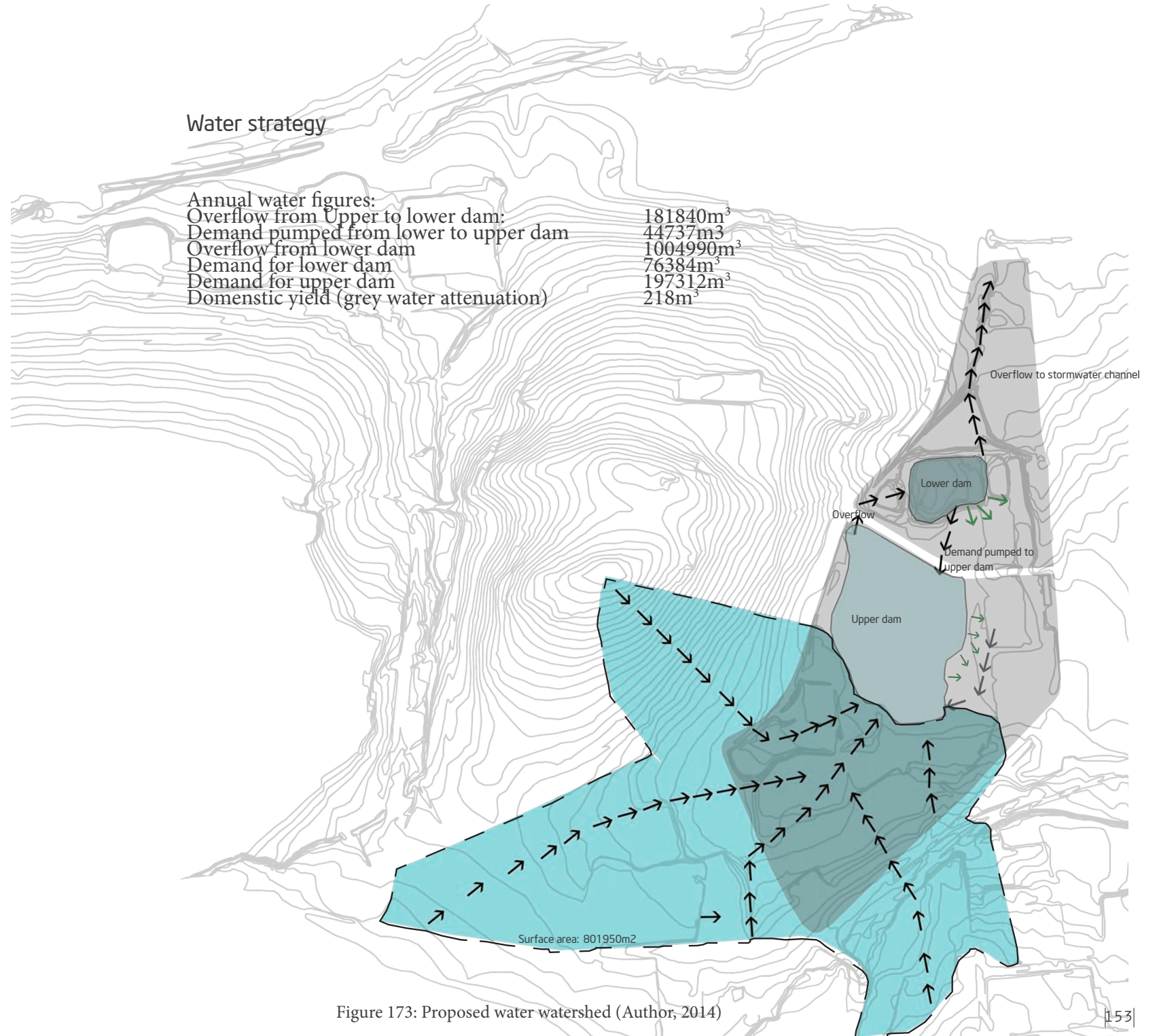

Figure 173: Proposed water watershed (Author, 2014)

6.4.2 Storm water management

1. Site levels allow storm water to flow into the respective dams where possible
2. The square level is lower than the water level of the dam. Rainwater on the square flows into bamboo planters. Water filters through the roots and is subsequently piped to a reservoir/ sump.
3. Grey water from the surrounding buildings is also piped into the sump, after passing through a fat, and silt trap.
4. Water in the reservoir is pumped into the wetland channel. The first segment of the wetland is a sub-surface flow. Sub surface means that the water enters the channel at the level of the roots. The second segment of the channel exposes the clean water to the surface of the leaves of the wetland.

6.5.2.1 Approach to irrigation of the site's vegetation

Drip irrigation on top of soil is covered in a mulch layer, to protect irrigation pipes. is proposed for both the bamboo and the endemic plants on site to minimise evaporation. Irrigation required by the bamboo is displayed in appendix 7.1, and forms part of the demand calculation for dam A.

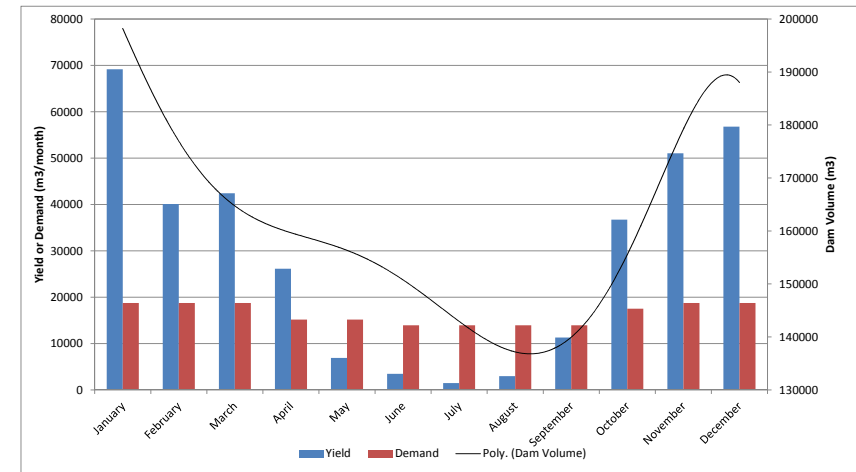

Graph 1 : Dam A's monthly Yield and demand (Author, 2014)

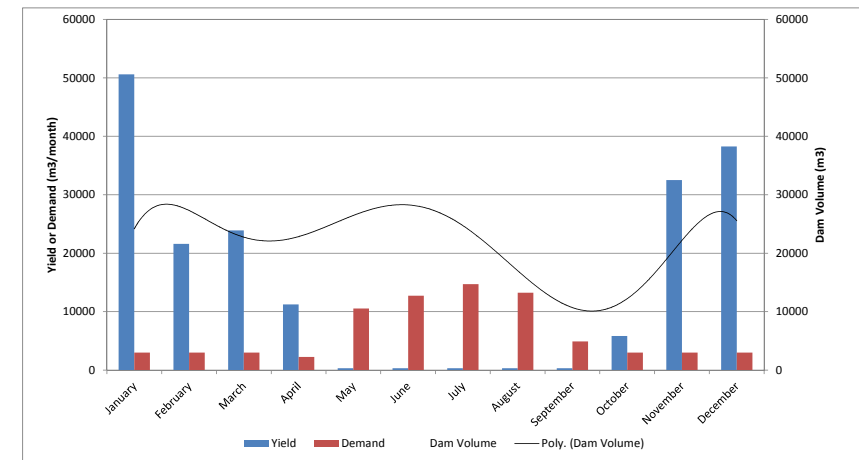

Graph 2: Dam B's monthly Yield and demand (Author, 2014)

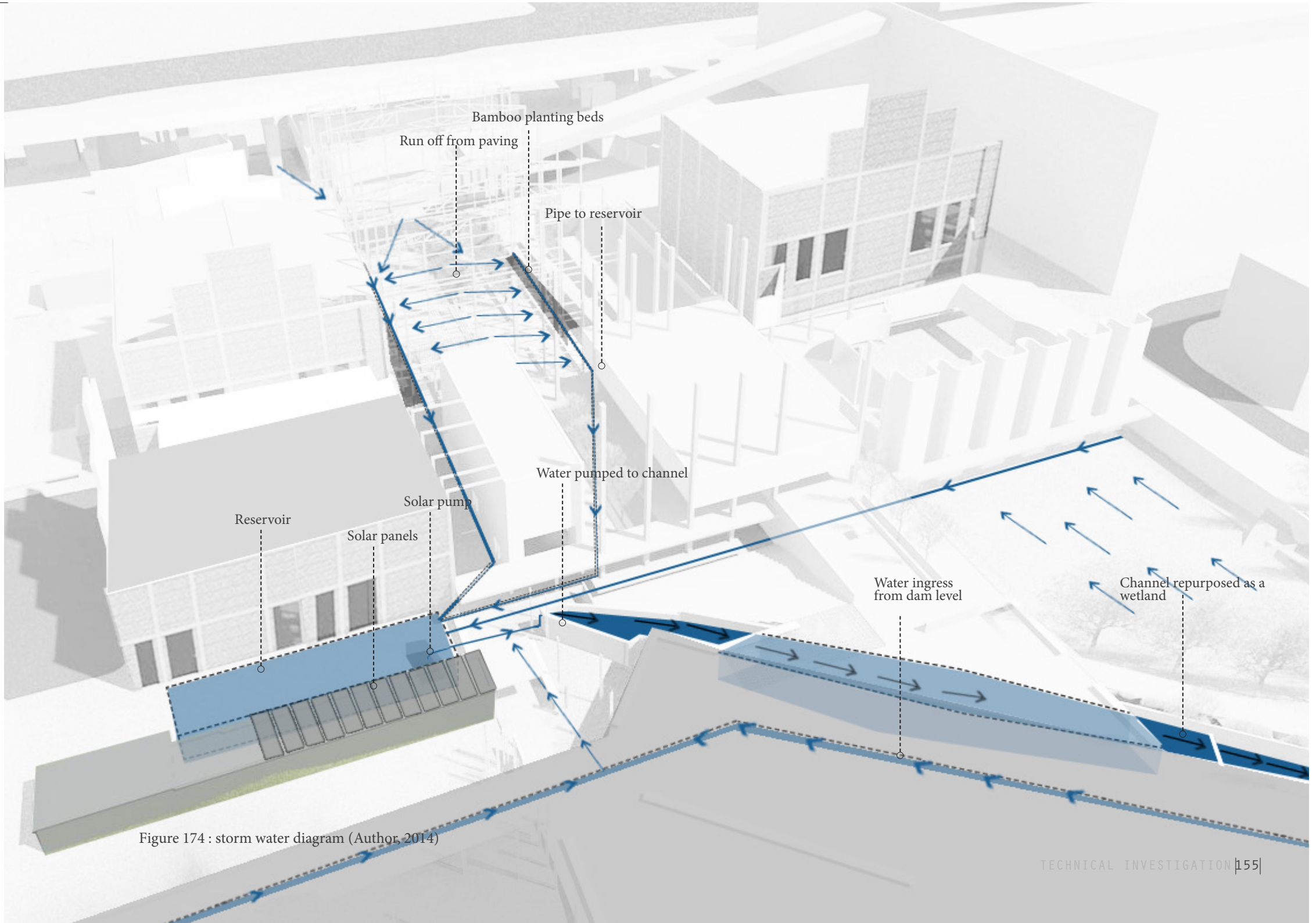

Figure 174 : storm water diagram (Author, 2014)

6.4.2.2 Channel repurposed as a wetland

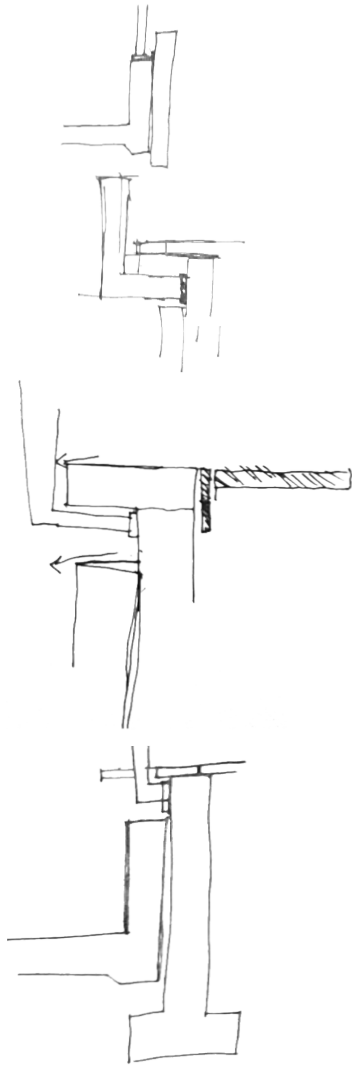

Figure 175: water channel edge concept (Author, 2014)



Figure 176 : Locality section (Author, 2014)



Figure 177: Re-appropriated channel (Wetland channel) (Author, 2014)

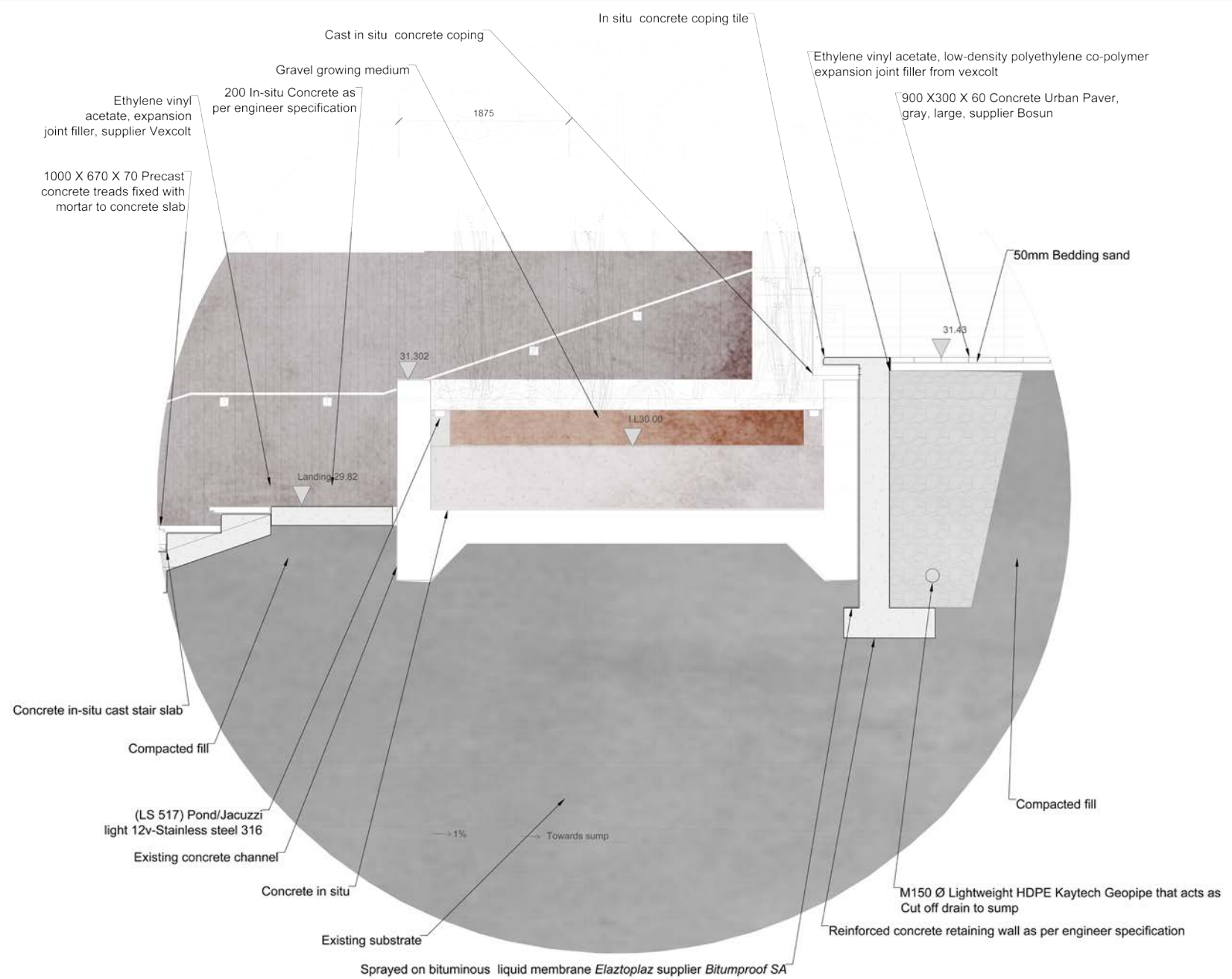

Figure 178: Section and axonometric cut section through wetland/existing water channel (Author, 2014)

6.4.3 Bamboo production

A bamboo economic viability study is shown in appendix 8.2. Bamboo culms are harvested after 3 years of growth. Only a third of the clump is harvested to maintain its spatial quality. Harvest of bamboo should take place when sap levels are at its lowest. Therefore bamboo is harvested in August, at the end of the dry season in Tshwane. Photosynthesis increases sap levels, therefore harvest takes place at dusk or dawn.

The bamboo culms dry in the existing metal structure as seen in previous chapter. the culms need to be kept dry in this period, therefore mechanically adjustable shutters on the frame ensure both shade for the users during the drying months and protects the drying culms from summer rains. The shuttering thus has a dual purpose in in shaping the public space and providing a productive function. The shutters can further be adjusted for shade, in the month of January and February when the square is at its hottest

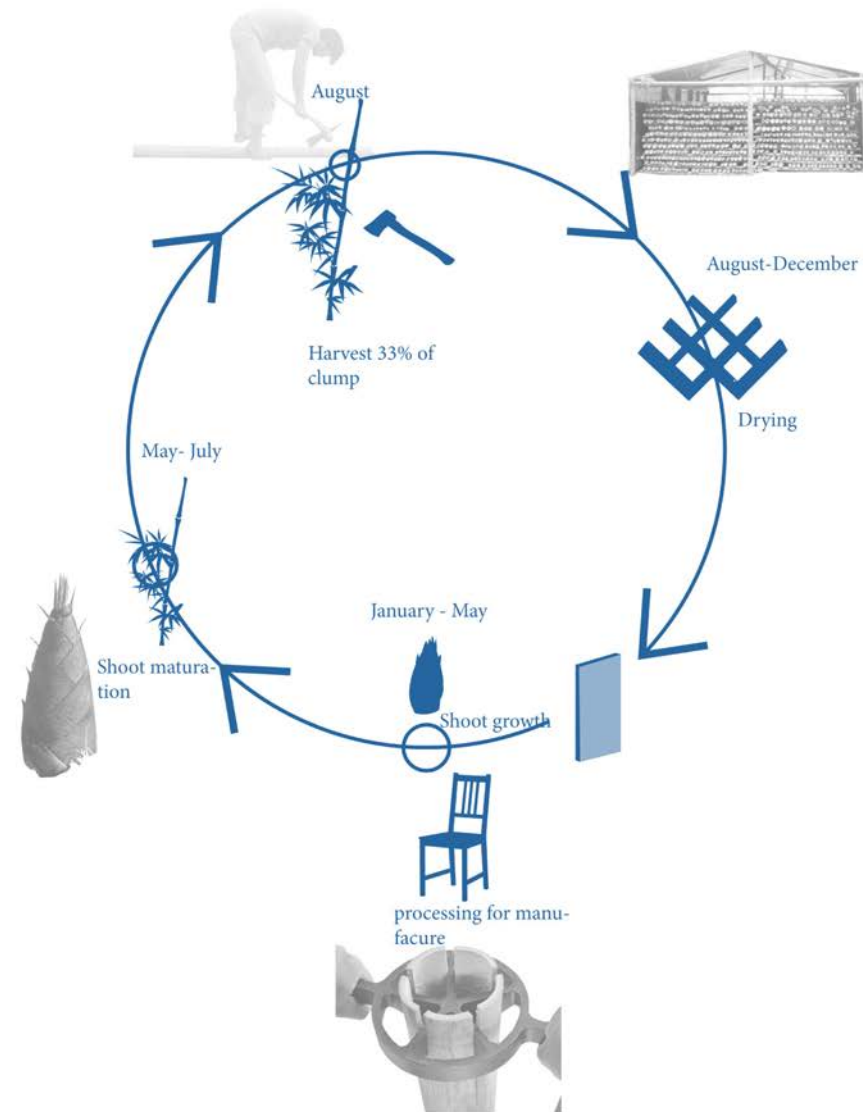

Figure 179: Bamboo process on in landscape (Author, 2014)

6.5 Space for nature

The landscape master plan provides biodiversity to the site and its context. Not only with the introduction

of vegetation but also with fresh water fish species and fauna species as an extension of the proposed vegetation.

The existing planting context provides the backdrop for the planting strategy and proposed species.

6.10.1 Planting Context

6.10.1.1 Existing

Species kept on

- | Species kept on | Specie name |
|-----------------|--|
| 1. | Acacia robusta (Hook thorn) |
| 2. | Acacia xanthophloea (Fever tree) |
| 3. ✓ | Arundo donax (Giant reed/ Spanish reed) |
| 4. ✓ | Bougainvillea (Bougainvillea) |
| 5. | Callisistemon viminalis (Bottle bush) |
| 6. | Campuloclinium macrocephalum (Pompom weed) |
| 7. | Canna indica (Indian shot) |
| 8. | Cardiospermum grandiflorum (Balloon vine) |
| 9. | Celtis africana (White stinkwood) |
| 10. | Datura ferox(Olie boom/ thorn apple) |
| 11 ✓ | Eucalyptus camaldulensis-(River red gum) |
| 12 ✓ | Encephalartos lebomboensis (Lebombo cycad) |
| 13. | Ipomoea purpurea (Morning glory) |
| 14. ✓ | Jacaranda mimosifolia (Jacaranda) |

Eradication

- NEMBA: category 1b remove with construction
Exotic removed
NEMBA: category 3 in Gauteng - remove with construction.
Transplanting prohibited
NEMBA: category 1b remove with construction
NEMBA: category 1b remove with construction
NEMBA: category 1b remove with construction
NEMBA: category 1b remove with construction
Not listed in urban transformed land
NEMBA: category 1b remove with construction
Not listed for urban areas in



Figure 180: Arundo donax (Author, 2014)

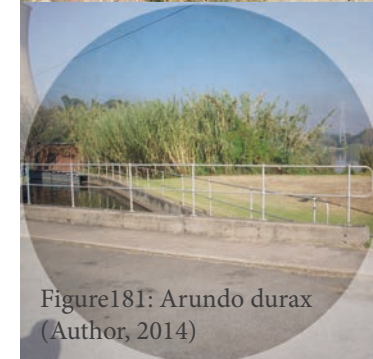

Figure 181: Arundo durax (Author, 2014)



Figure 182: Peonix canariensis (Author, 2014)

- | | | |
|-------|---|---|
| 15. | Juncus acutes (Spiny rush) | Gauteng
Prohibited alien species in terms of section 67 (1) |
| 16. | Lantana species (Lantana, Thick berry) | NEMBA: category 1b remove with construction |
| 17. | Melia azedarach (Sering) | NEMBA: category 3 in Gauteng - remove with construction. |
| 18. | Nasella trichotoma | Transplanting prohibited (Serrated tussock) NEMBA: category 1b remove with construction |
| 19. ✓ | Phoenix canariensis(Canary island date palm) | |
| 20. ✓ | Rhus lancea (Karee) | |
| 21. ✓ | Sterlitzia nicolai (Giant white bird of paradise) | |
| 22. ✓ | Sterlitzia reginae (Sterlitzia) | |

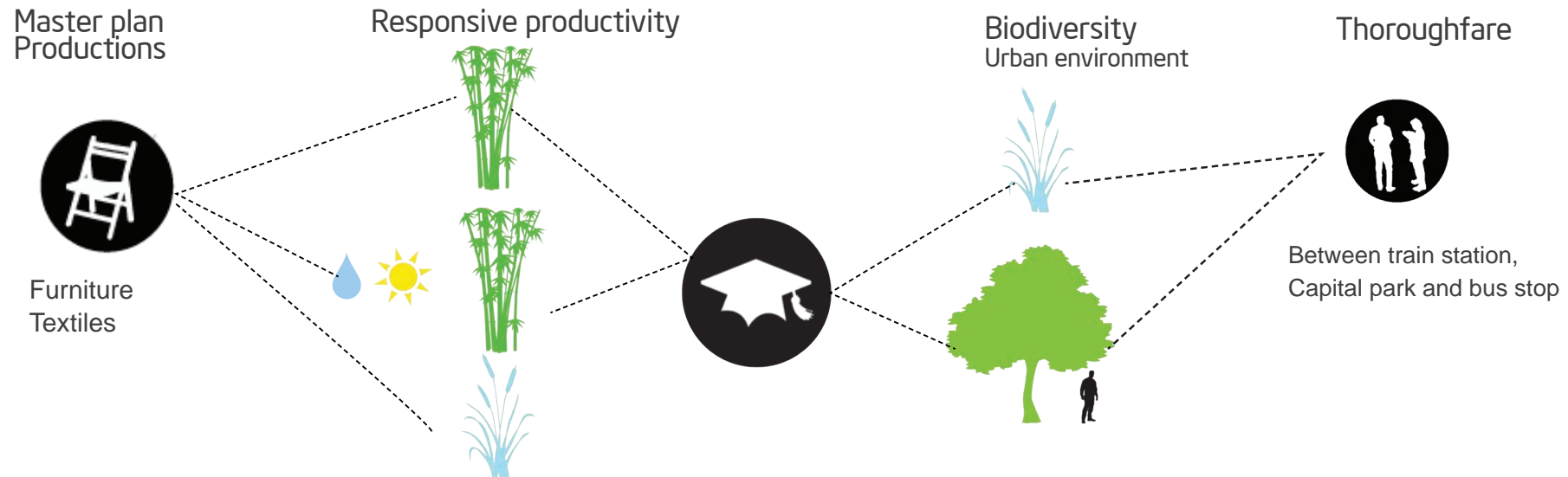

Figure 183: Planting approach in reference with dissertation intentions (Author, 2014)

6.10.2 Planting Strategy

7.9.1.2 Bamboo

Communities

Companion planting enhances the bamboo production: Species in the legume family can provide essential nitrogen (Hanson, 2009) like the indigenous *Crotalaria capensis* (Cape-rattlepod). Bacteria in the roots of the *Crotalaria capensis* and other plants in the

legume family nitrify atmospheric nitrogen making it available to the plant that hosts it. When the plant dies, the nitrogen is released into the soil, making it available to other plants. They are considered good pioneer plants for this reason (Viljoen, 2007). The nitrogen

made available to the soil is small, but is still used as an understory plant. Annual legumes are proposed to ensure an annual release of nitrogen to the soil.

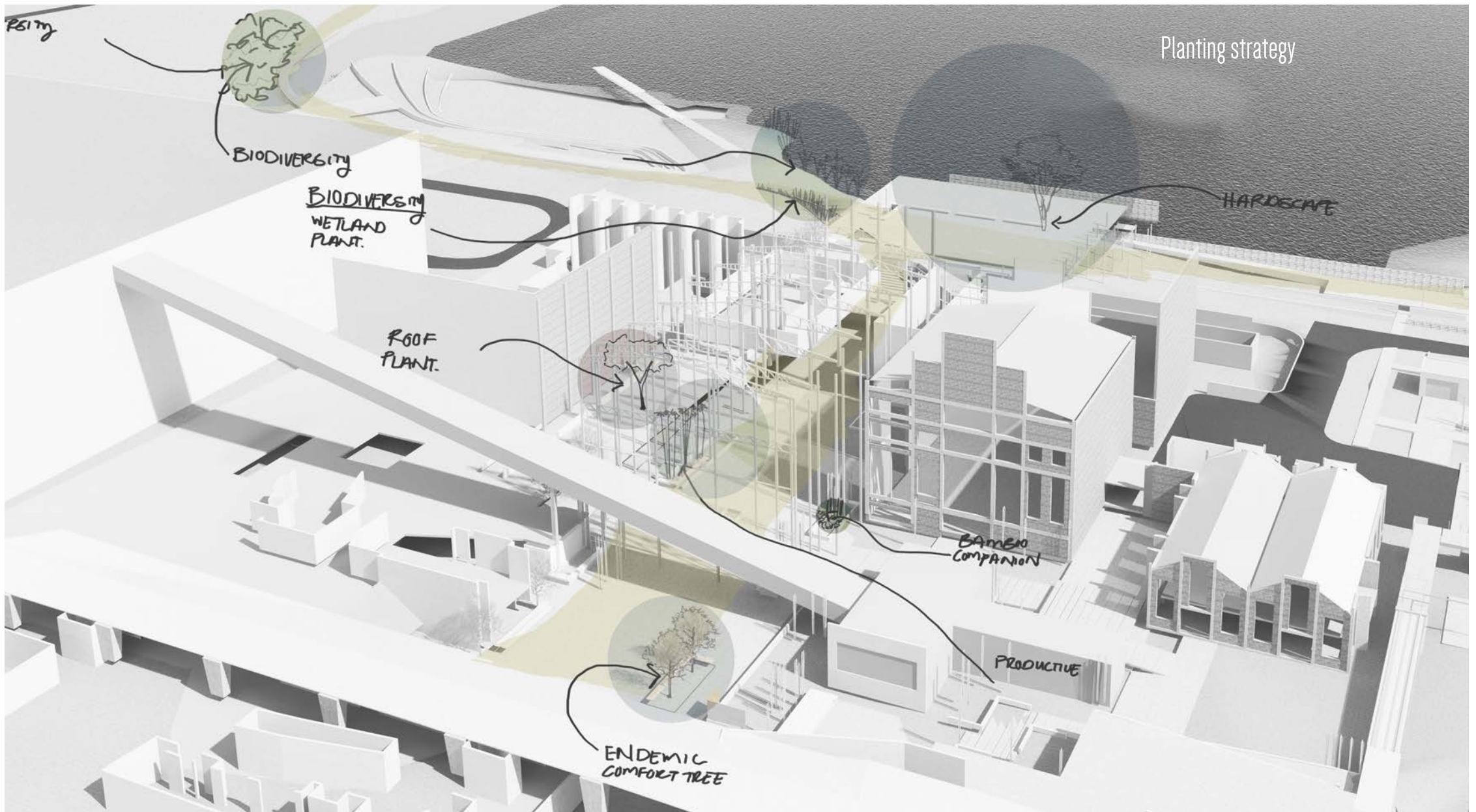

Figure 184: Image indicating the planting on site (Author 2014)

Species planted for production reasons







Specie name	Selection purpose	area planted
 1. <i>Andropogon huillensis</i> (Oldmans beard)	Responsive production . Similar growing conditions: well drained soil and high water demand. (Companion properties with bamboo)	Where bamboo is planted
2. <i>Bambusa balcoa</i> (Giant bamboo)	Responsive productive (Main timber Producer) (Length 21m)	All areas (avoiding north facing windows)
 3. <i>Bambusa glaucophylla</i> (Malay Dwarf)	Responsive productive (Product: staking because of species solid culm) (length 3m)	In front of north and east facing windows
 4. <i>Bambusa sp. 'Hirose'</i> (Hirose)	Responsive productive (Product: timber)(Length 18m)	All (avoid north facing windows)
 5. <i>Bambusa textilis</i> var. <i>gracilis</i> (Graceful Weavers)	Responsive productive (Product: textiles)(Length 7m)	All
 6. <i>Brachiaria brizantha</i> (Bread grass)	Responsive production: Similar habitat needs. Shade grass	Square
 7. <i>Crotalaria capensis</i> (Cape rattle rod)	Responsive production Nitrifies soil plant dies back when dies. Annual species	Where bamboo is planted
8. <i>Cymbopogon excavatus</i> (turpentine grass)	Responsive production. Species with similar growing conditions	Where bamboo is planted
9. <i>Enneapogon scoparius</i> (Bottle brush grass)	Responsive production: Similar habitat needs. Shade grass	Square
10. <i>Ehrharta erecta</i> (panic veld grass)	Responsive production: Similar habitat needs. Naturally grows in forests (requires minimal sun)	Centre of bamboo planted areas
11. <i>Eragrostis trichophora</i> (Hary flower love grass)	Responsive production: Similar habitat needs.	Where bamboo is planted (excluding square, high sun requirement)
12. <i>Eragrostis imanoema</i> (Tite grass)	Responsive production. Similar growth environment	Where bamboo is planted
13. <i>Londentia Simplex</i>	Responsive production: Similar habitat needs . High water requirement and well drained soil	Waterfront
14. <i>Pearsonia sessilifolia</i> (silverertjietee)	Responsive production. Companion properties of Nitrifying soil. Will easily re-establish after harvest	Where bamboo is planted
15. <i>Phyllostachys aurea</i> (Aurea bamboo)	Naturalised species of bamboo used for production. Stragglng variety	Far away from buildings
16. <i>Sphenostylis angustifolia</i> (Wild sweet pea)	Responsive production. Species has companion properties of :Nitrifying soil. Annual plant. Full sun required edges where it will receive sufficient sun	Where bamboo is planted, on the Northern or western
17. <i>Sporobolus fimbriatus</i> (Fringed dropseed)	Responsive production. Similar growth environment	Square, where bamboo is planted
18. <i>Setaria megaphylla</i> (Ribbon grass)	Responsive production: Similar habitat needs.	Square
19. <i>Setaria sphacelata</i> (African bristle grass)	Responsive production: Similar habitat needs	Where bamboo is planted
20. <i>Setaria verticillata</i> (Bristly foxtail)	Responsive production: Similar growth needs can grow in shade	Square



Figure 185:
Bambusa glaucophylla
(Hankey, 2004)



Figure 186:
Bambusa textilis
(Masupa, 2012)



Figure 187:
Bambusa hirose
(Masupa, 2012)



Figure 188:
Bambusa balcoo
(Notten, 2002)

 1. <i>Allium schoenoprasum</i> (Chives)	Companion properties to bamboo, and food yield	Sunny edge of the bamboo crop
 2. <i>Cyperus marginatus</i> (Matjiesgoed)	Responsive production: Water treatment	Water channel and dam edge
3. <i>Cyperus textilis</i> (Mat sedge)	Responsive production: Water plant and textile product	Water channel
4. <i>Cyperus sexangularis</i> (Bessies gras)	Responsive production: Water treatment	Water channel and dam edge
5. <i>Juncus glaucus</i> (Bluerush)	Responsive production: Water treatment	Water channel and dam edge
6. <i>Leersia hexandra</i> (Southern cut grass)	Responsive production: Water treatment	Water channel
7. <i>Melissa officinalis</i> (Lemon balm)	Companion plant to the bamboo, and food yield	Sunny edge of the bamboo crop
8. <i>Mentha</i> (Mint)	Companion plant to the bamboo, and food yield	Sunny edge of the bamboo crop
9. <i>Paspalum distichum</i> (Knot grass)	Responsive production: Water treatment	Water channel
10. <i>Petroselinum crispum</i> (Parlsey)	Companion plant to the bamboo, and food yield	Sunny edge of the bamboo crop
11. <i>Phaseolus vulgaris</i> (Common bean)	Companion plant to the bamboo, and food yield	Sunny edge of the bamboo crop
12. <i>Schoenoplectus corymbosus</i>	Responsive production: Water treatment	Water channel
13. <i>Typha capensis</i> (Bulrush)	Responsive production: Water treatment	In channel wetland
14. <i>Zingiber officinale</i> (Ginger)	Companion properties to bamboo, and food yield	Bamboo crop

Figure 189: Productive planting areas on master plan (Author, 2014)

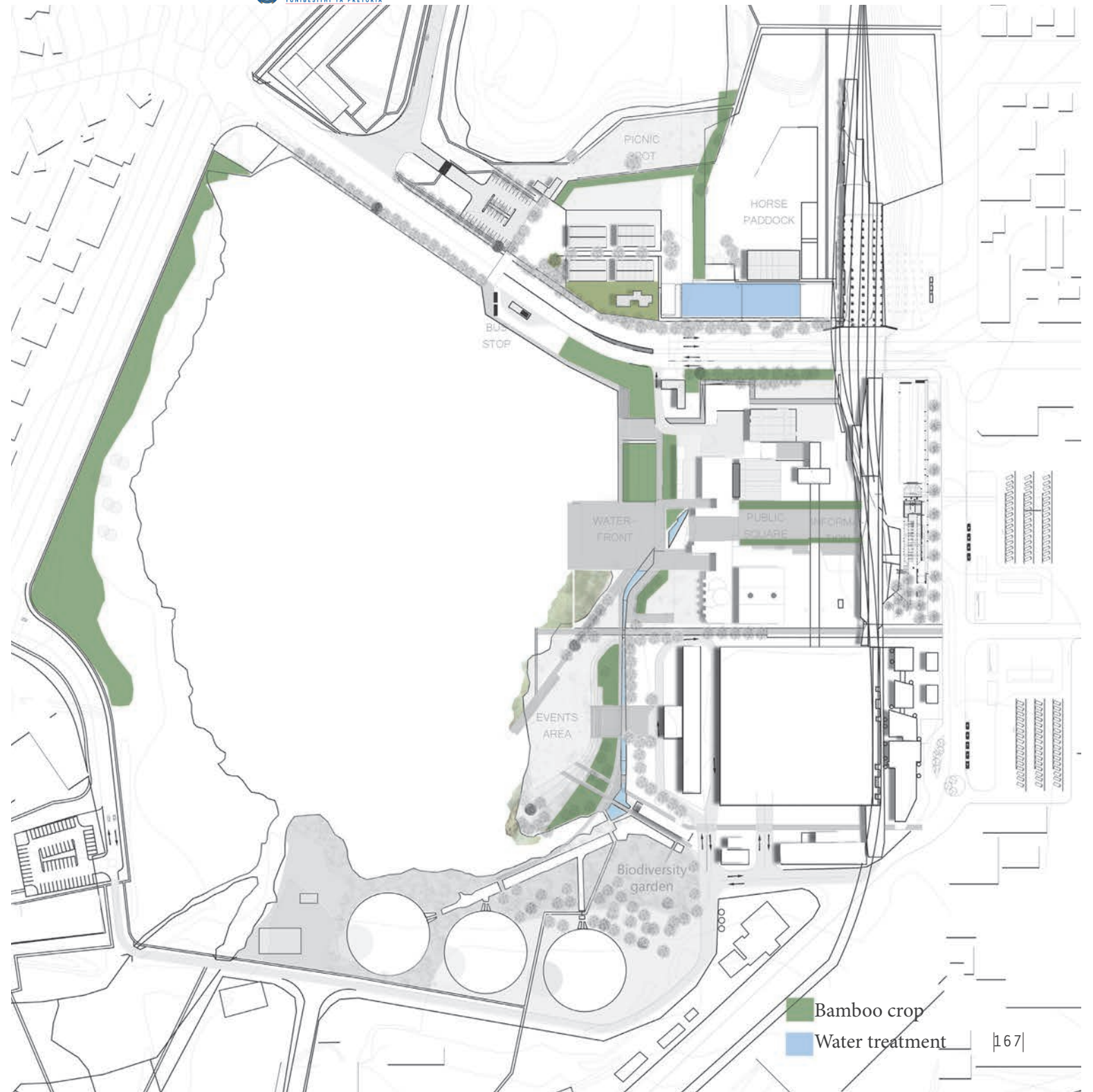

Biodiversity	Selection Purpose	Area to plant
<p> Vegetation unit plants used in urban environment</p> <p>1. <i>Acacia Caffra</i> (Hook thorn)</p> <p>2. <i>Combretum apiculatum</i> (Red bush willow)</p> <p>3. <i>Combretum erythrophyllum</i> (River bushwillow)</p> <p>4. <i>Combretum molle</i> (Velvet bush willow)</p> <p>5. <i>Croton gratissimus</i> (Lavender fever berry)</p> <p>6. <i>Cussionia paniculata</i> (Mountain cabbage tree)</p> <p>7. <i>Dombeya rotundifolia</i> (Wild pear)</p> <p>8. <i>Lansea discolor</i> (Live-long, tree grape)</p> <p>9. <i>Pappea capensis</i> (Jacket plum)</p> <p>10. <i>Peltophorum africanum</i> (African wattle)</p>	<p>Biodiversity: Marikana Thornveld vegetation unit. Medium Sized tree suited for urban environment. Mark able change in seasons</p> <p>Biodiversity: Marikana Thornveld vegetation unit. Waterfront Suited for urban environment. Deciduous shade tree</p> <p>Biodiversity: Marikana Thornveld vegetation unit. Medium sized tree suited for urban environment. Mark able change in seasons</p> <p>Biodiversity: Marikana Thornveld vegetation unit. Medium sized tree suited for urban environment. Mark able change in seasons</p> <p>Biodiversity: Marikana Thornveld vegetation unit. Markable change in seasons and fragrant</p> <p>Biodiversity: Marikana Thornveld vegetation unit.</p> <p>Biodiversity: Marikana Thornveld vegetation unit. Medium sized tree suited for urban environment. Mark able change in seasons</p> <p>Biodiversity: Marikana Thornveld vegetation unit. Medium sized tree suited for urban environment. Mark able change in seasons</p> <p>Marikana Thornveld vegetation unit. Medium sized tree suited for urban environment</p> <p>Biodiversity: Marikana Thornveld vegetation unit. Medium sized tree suited for urban environment.</p>	<p>Bio diversity garden</p> <p>Waterfront</p> <p>Square</p> <p>Square</p> <p>Biodiversity garden</p> <p>Biodiversity garden</p> <p>Square to waterfront</p> <p>Square to waterfront</p> <p>Square and biodiversity garden Square to waterfront</p>
<p>Water plants</p> <p>1. <i>Digitaria monodactyla</i></p> <p>2. <i>Eragrostis gummiflua</i> (Gumgrass)</p> <p>3. <i>Nymphae nouchali</i> (Blue water lily)</p> <p>4. <i>Phramites australis</i> (Common reed)</p> <p>5. <i>Juncus glaucus</i> (Blue rush)</p> <p>6. <i>Schizachyrium sangium</i></p>	<p>Biodiversity: Water edge</p> <p>Biodiversity: Water plants</p> <p>Biodiversity: Water plants</p> <p>Biodiversity: Water plant</p> <p>Biodiversity: Water plants</p> <p>Biodiversity: Water plants</p>	<p>Waterfront</p> <p>Dam edge</p> <p>Dam edge</p> <p>Dam edge, water channel</p> <p>Dam edge</p>



Figure 190:
Juncus glaucus
(Dave, 2012)

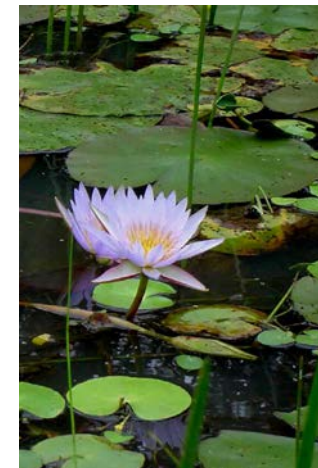
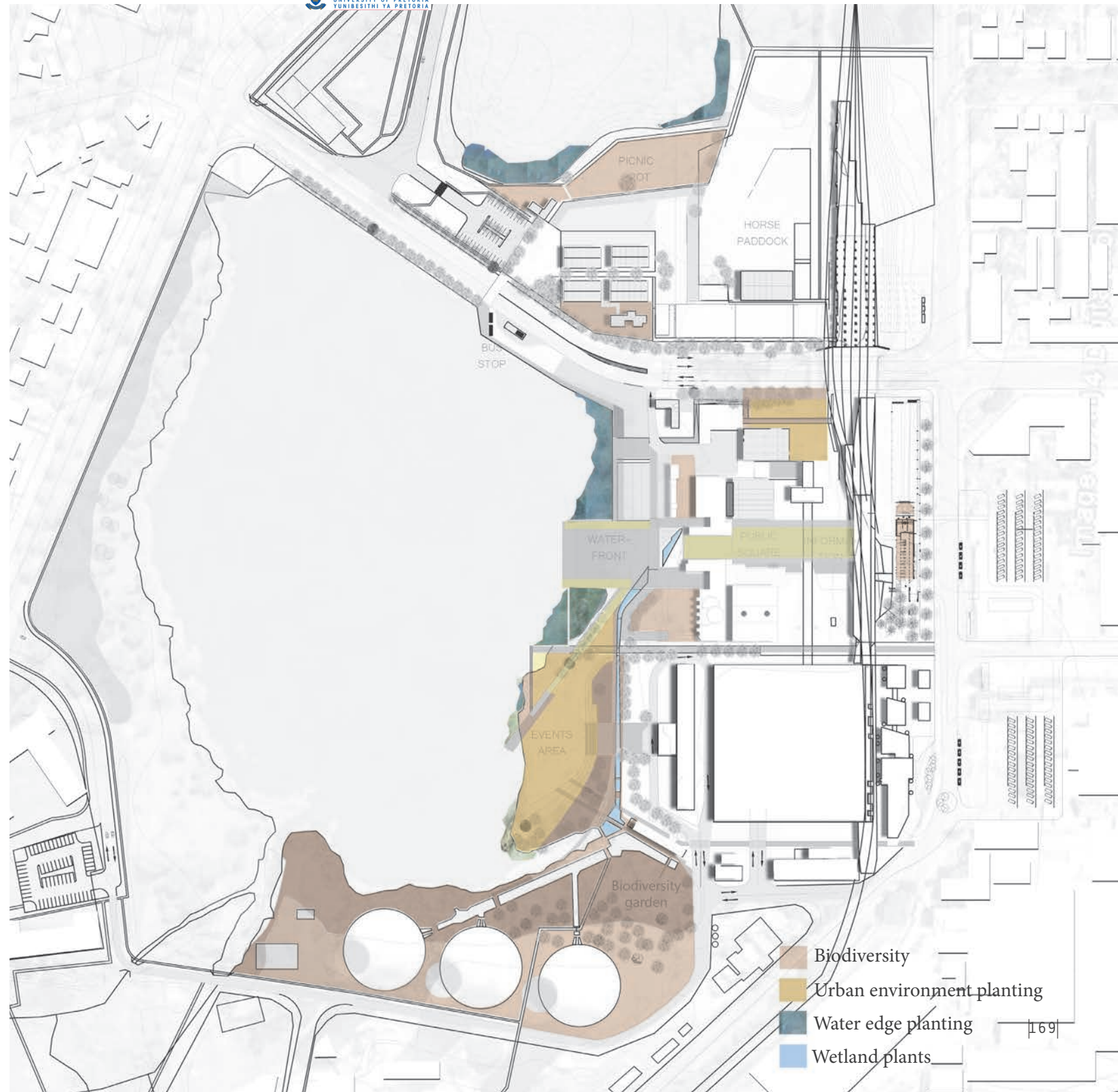

Figure 191:
Nymphaea nouchali
(Notten, 2002)

Figure 192: Biodiversity planting areas (Author, 2014)





Kiggelaria africana

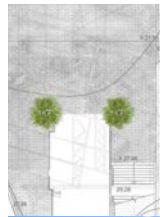

Pappia capensis



Combretum erythrophyllum



Bambusa textilis, Bambusa glaucophylla



Bambusa balcooa

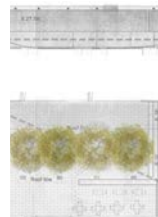

Combretum molle



Harpephyllum cafferum

Figure 193: Planting layout lower level (Author, 2014)

6. 10.3 Planting application
Planting layout upper level

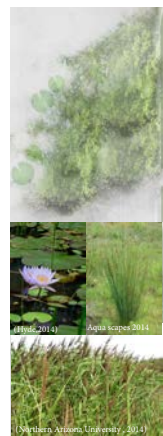
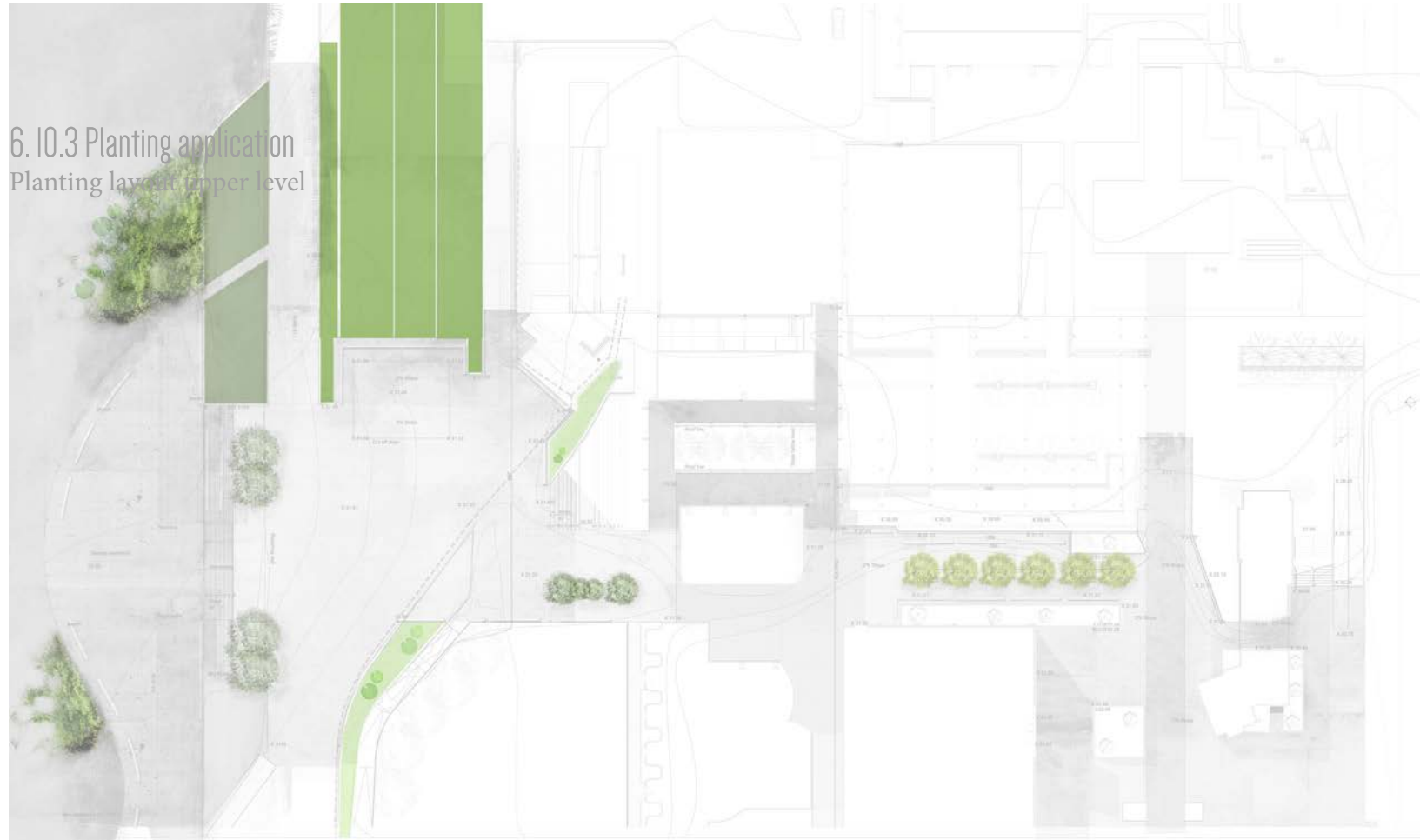

Nymphaea nouchali, *Juncus glaucus*, *Phragmites australis*



Bambusa 'highrose'

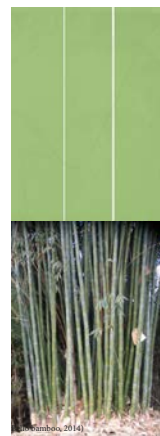

Bambusa balcooa



Celtis africana



Dombeya rotundifolia



Cyperus marginatus

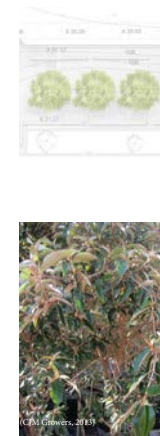

Croton gratissimus

Figure 194: Planting layout upper level (Author, 2014)



Bambusa balcoa *Crotalaria capensis*



Pappea capensis



Combretum erythrophillum



Setaria megaphylla



Sporobolus fimbriatus



Combretum molle



Dombeya rotunda



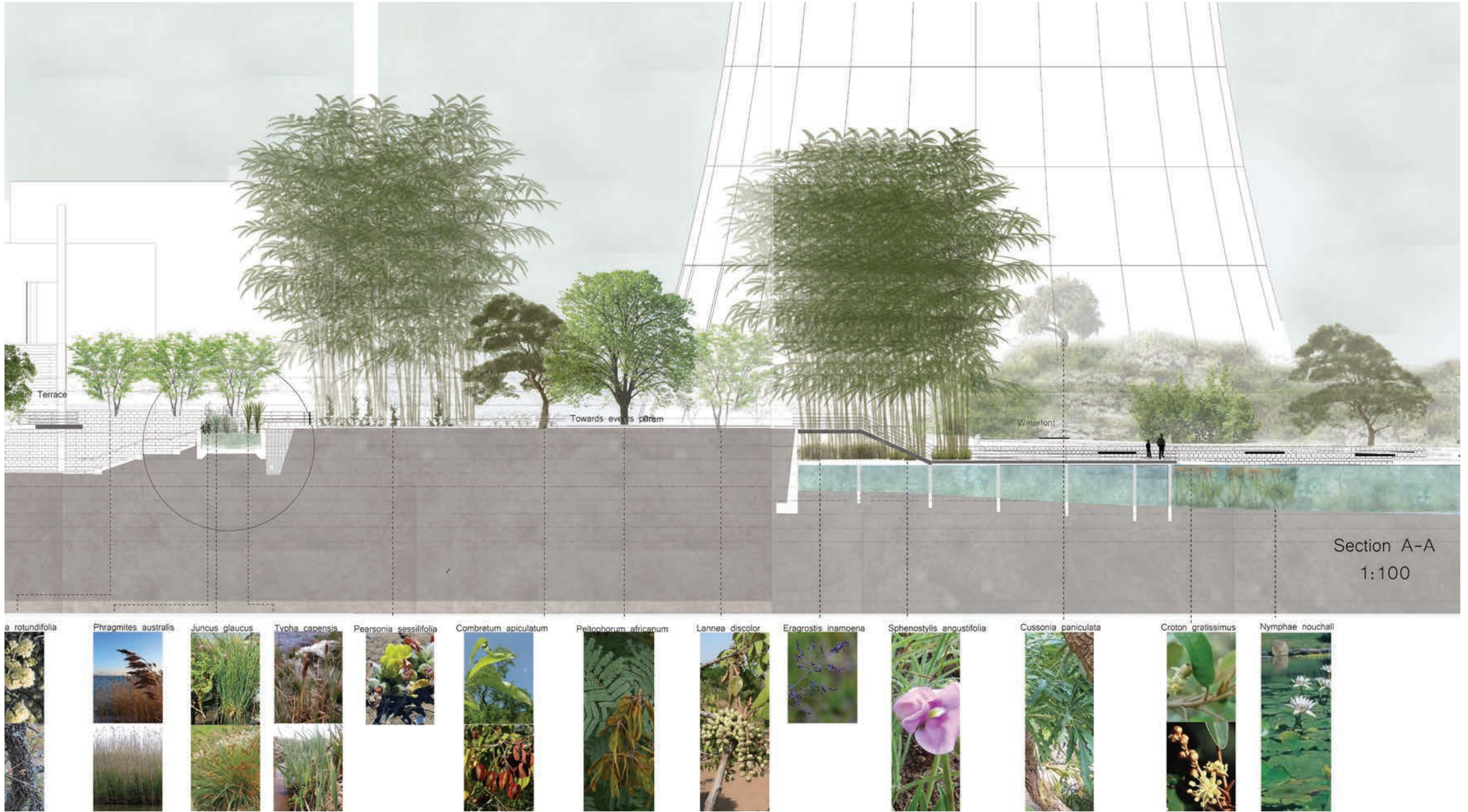

Figure 195: SectionA-A displaying planting application
(Author, 2014)

6.4 Edge conditions/ interface

The previous sections of this chapter discussed technical resolution of man, his productions and nature independently. The final section of this chapter discusses the interface between the three mentioned objectives.

6.4.1 Materials, properties and finishes

Materials are chosen to compliment the industrial material palette of the site and to comply with the theoretical intentions of creating a biophilic urban environment. The materials as a collective form the interface between the user, the productions and nature. The precedent mentioned in the previous chapter *The Forest @ Pyne* by Sansiri by TROP contrasts natural materials with synthetic materials to place emphasis on the natural. The proposed

material palette additionally contrasts with the aged materials of the site. The main materials introduced are:

Material

- Shuttered concrete

Reason

Wood shuttered concrete displays the natural grain of the shuttering. According to biophilic guidelines, materials displayed with an organic motif will resonate in people. The shuttered concrete is used in contrast with natural, light vertically compressed bamboo and the existing red brick presence in the site.

Material

- Vertically compressed bamboo

Reason

The application of bamboo can become visible to the user. Bamboo is used as a substitute for soft

wood applications. Biophilic guidelines support the use of natural materials over synthetic materials.

Material

- Steel

Reason

Steel in the landscape is an extension of the site context. Steel allows for transparency because of its ability to span great lengths.

Material

- Bamboo

Reason

The size (21m) of the bamboo in the landscape renders it a landscape material. The clumps will have culms of different ages. The colour of the culms will therefore differ according to the age of the culm. The variation in colour adds to the biophilic elements of the site.

Material

- Expanded metal mesh

Reason

The expanded metal mesh is used on the ramp. It allows light to filter to the plants planted beneath the ramp and into the building adjacent to the ramp. The metal mesh responds to the industrial context.

Material

- Urban concrete pavers

Reason

The urban concrete paver is specified to serve 2 purposes. Functionally the pavers are applicable for high traffic zones. Secondly, the pavers ensure a fast runoff of rainwater. The specified concrete paver varies in color and grain

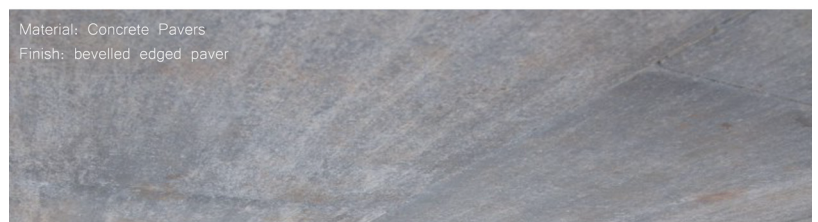
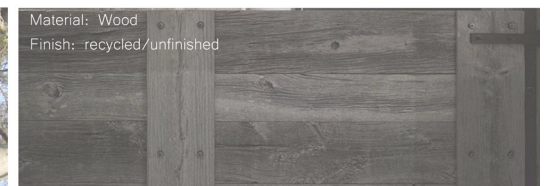
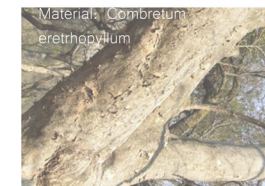
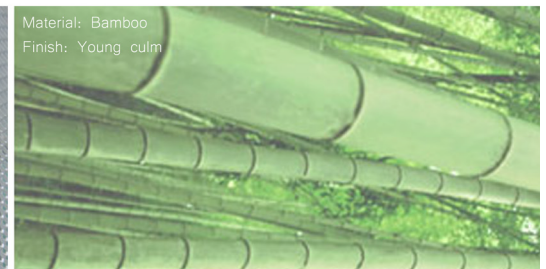
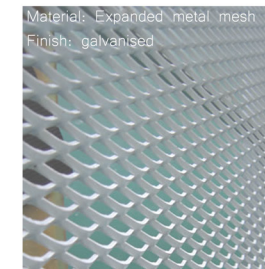
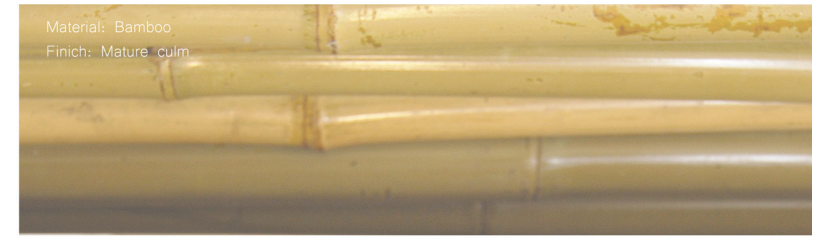

Figure 196: Material palette (Author, 2014)



Figure 197: Locality section (Author, 2014)

6.II Details

6.II.I Edge conditions: Wet to dry Waterfront



Figure 198: Axonometric cut section through waterfront displaying piling support system for the deck (Author, 2014)

6.II. 2 Edge conditions: Pergola construction

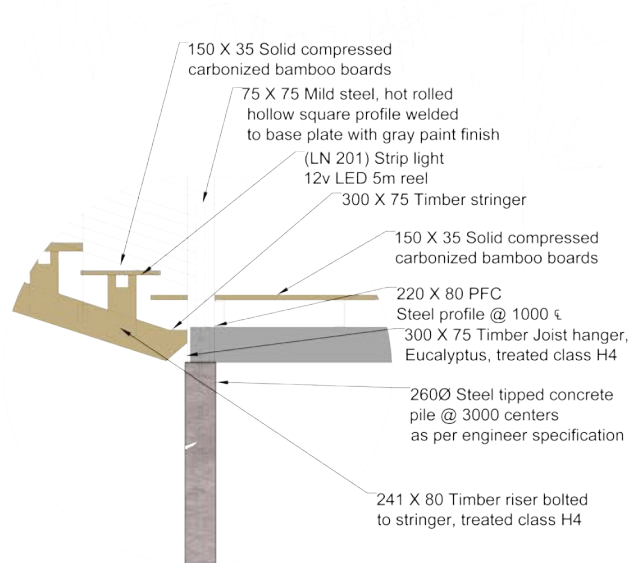

Figure 200: Detail 1 (Author, 2014)

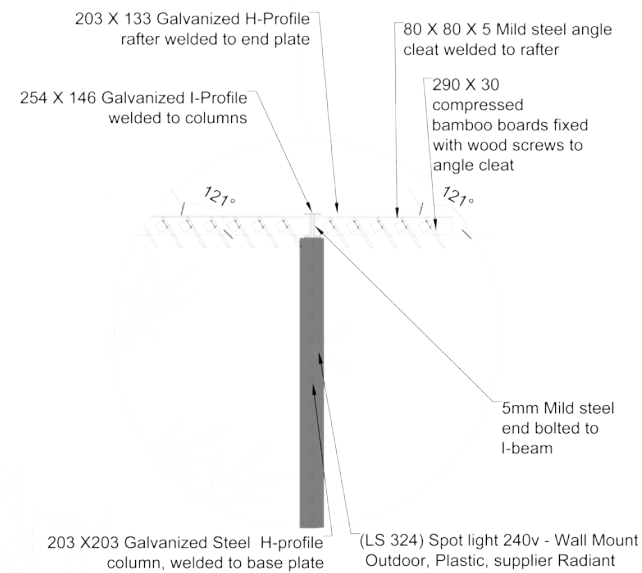

Figure 201: Detail 2 (Author, 2014)

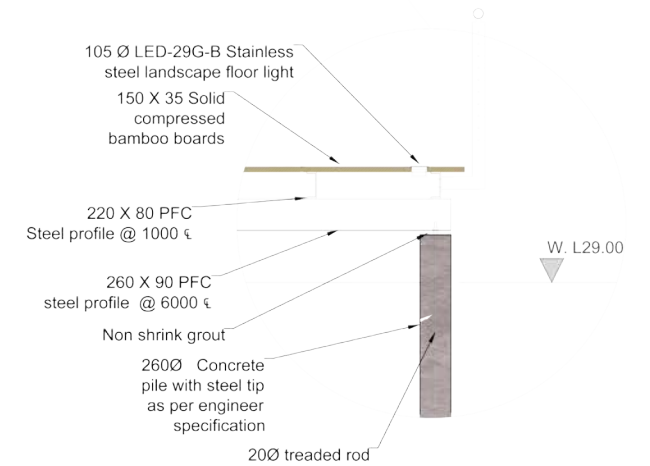

Figure 202: Detail 3 (Author, 2014)

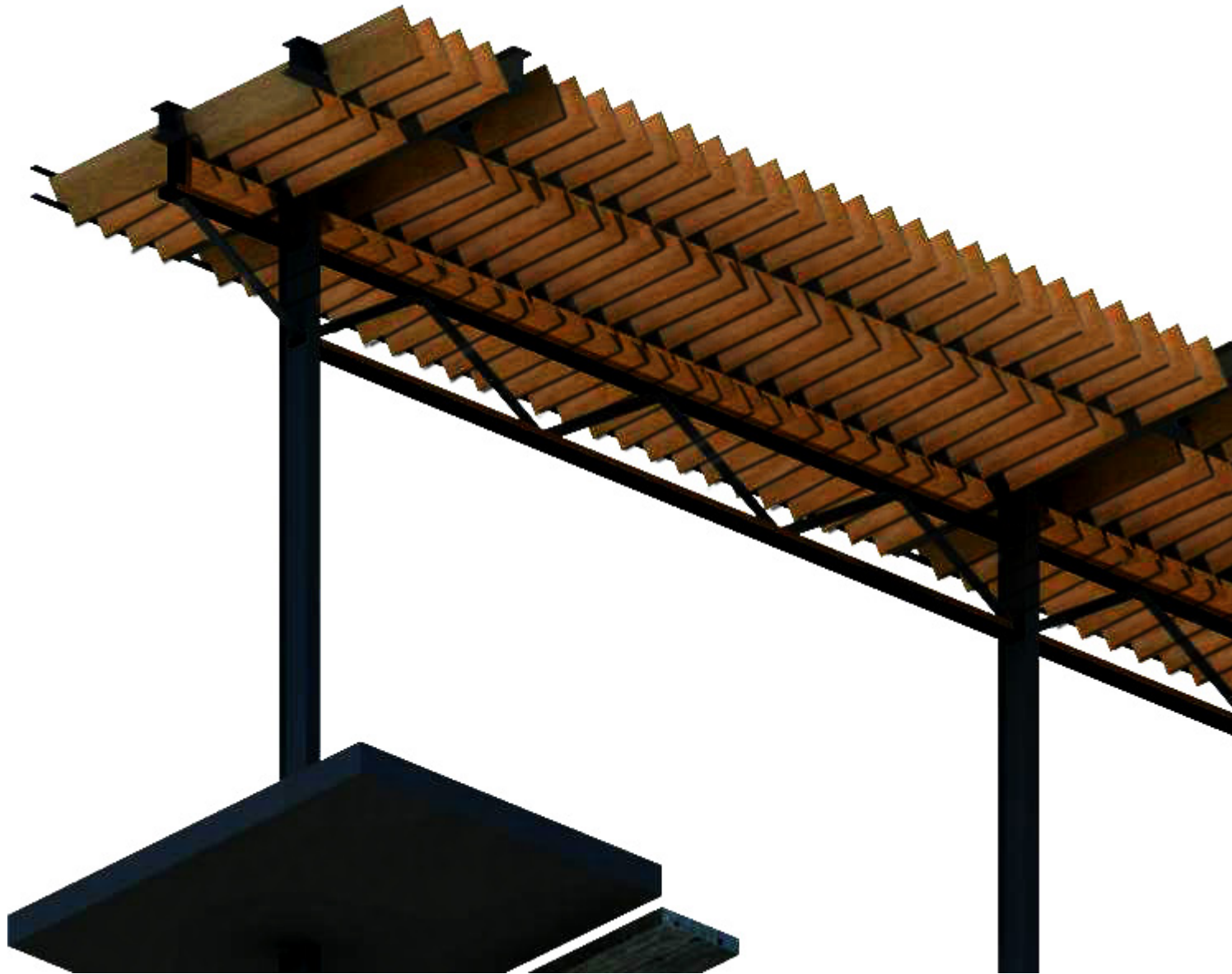

Figure 203: pergola 3D(Author, 2014)

6.II. 2 Edge conditions: Over head walk ways

Upper deck

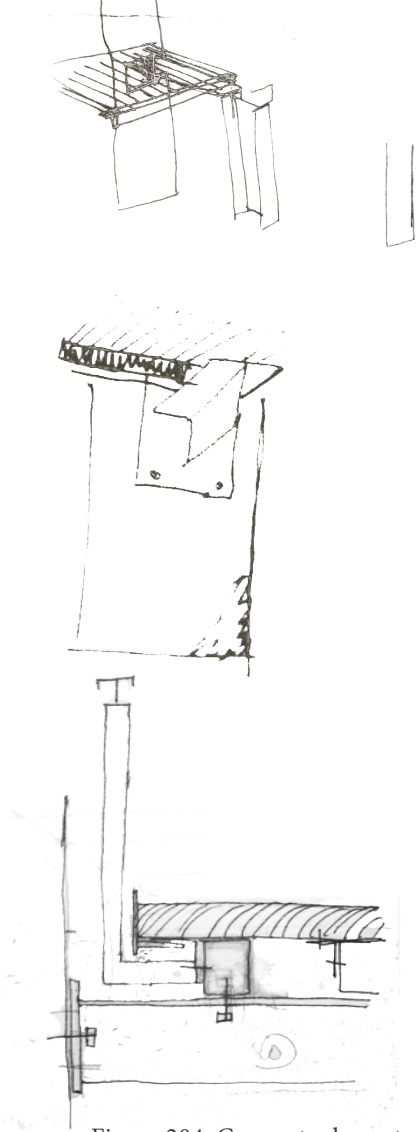

Figure 204: Conceptual construction drawings of deck connection with existing column (Author, 2014)



Figure 205: Locality section (Author, 2014)



Figure 206: Axonometric cut section through upper deck walkway (Author, 2014)

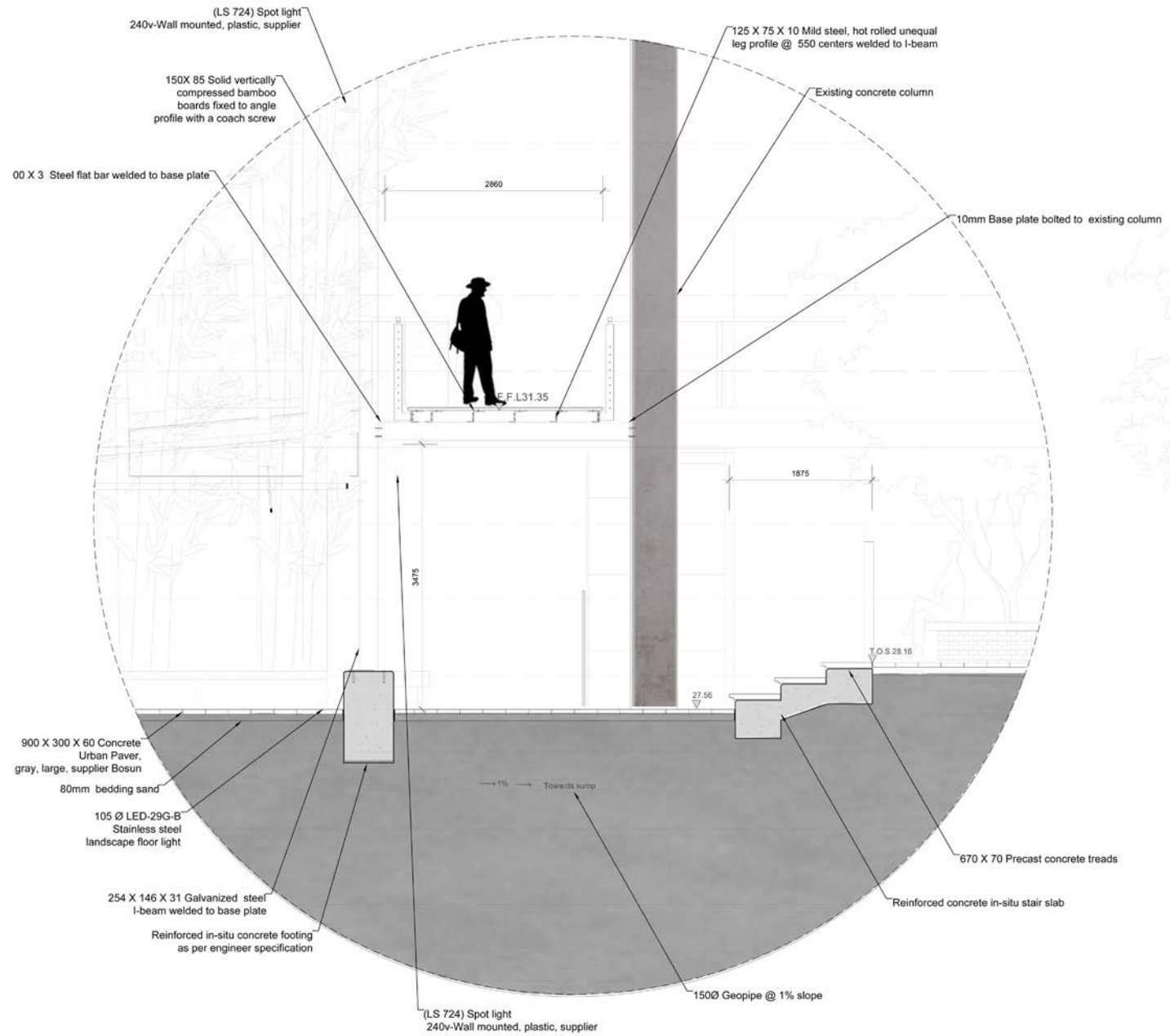

Figure 207: Section through upper deck walkway (Author, 2014)

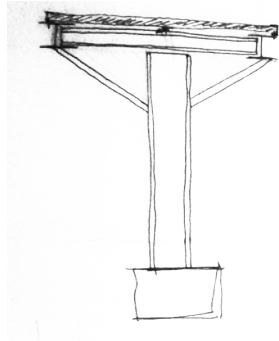

Figure 208: Conceptual construction drawing of ramp (Author, 2014)

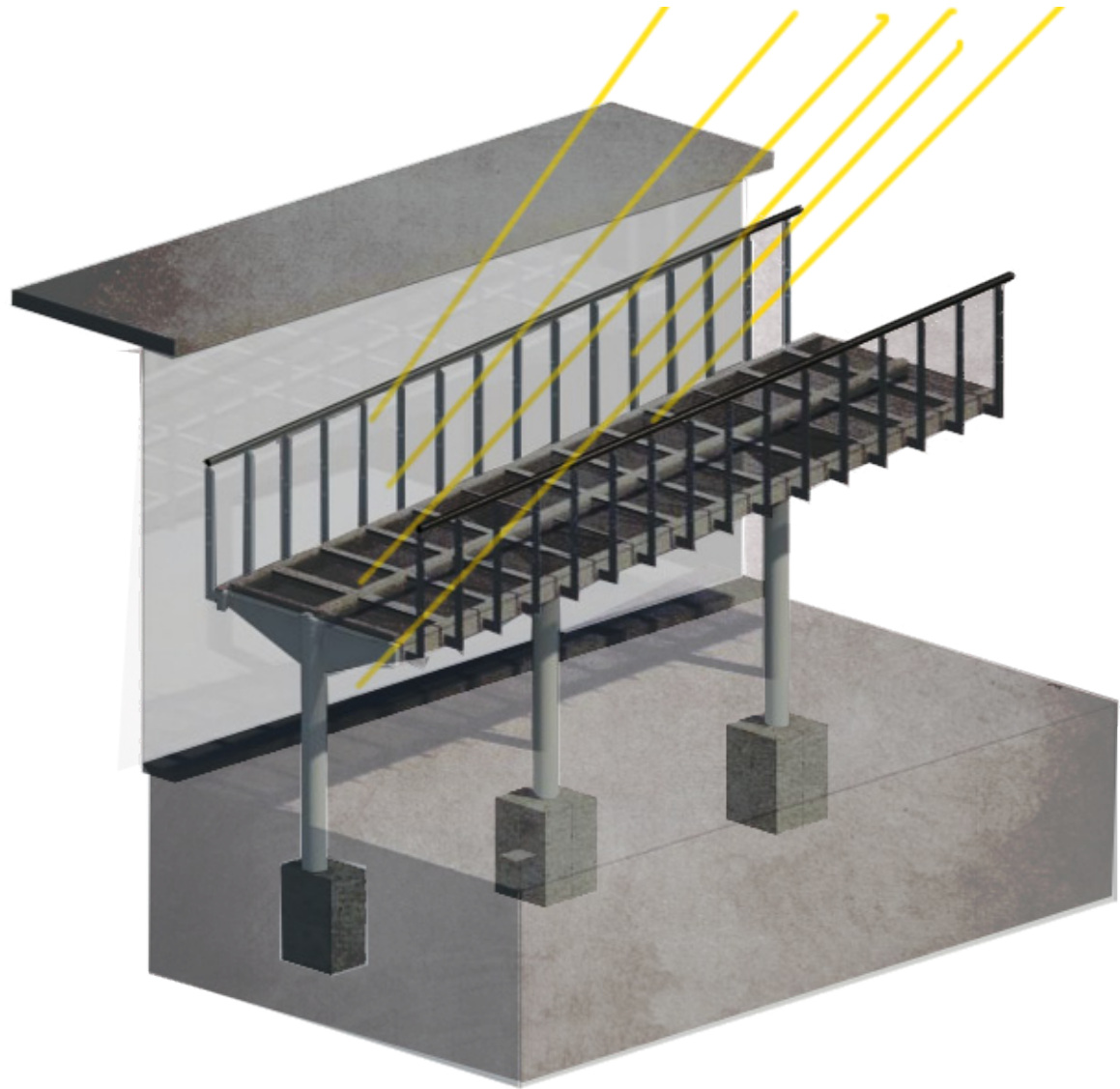

Figure 209: 3d of construction allowing lighting to adjacent building facade (Author, 2014)

6.11.3 Ramp construction

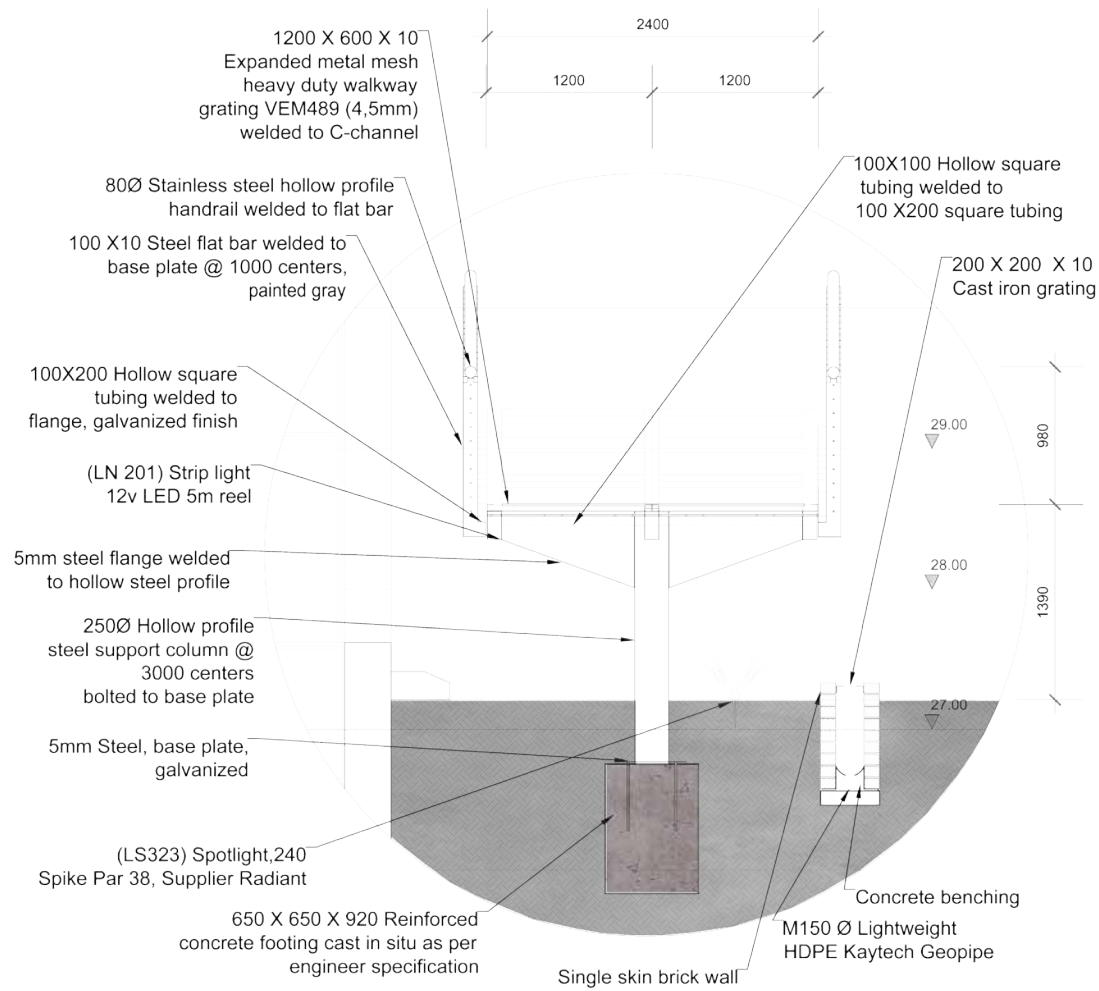

Figure 210: Ramp exploded section and detail drawing (Author, 2014)

6.5. Site Rating

The SBAT rating tool was combined with the SITES Version 2 rating system to determine the sustainability of the proposal. This rating tool is applied to the sketchplan, as this area that is technically resolved.

6.5.1 Baseline

The baseline of the study is the Framework proposal for 2010. The site's location in relation to amenities such as banks, schools, doctors etc. stays unchanged during the iteration process.

The man made dam is considered as an existing lacustrine water body. Criteria and points allocated to the existing dam is given as if the dam is a natural feature to the site.

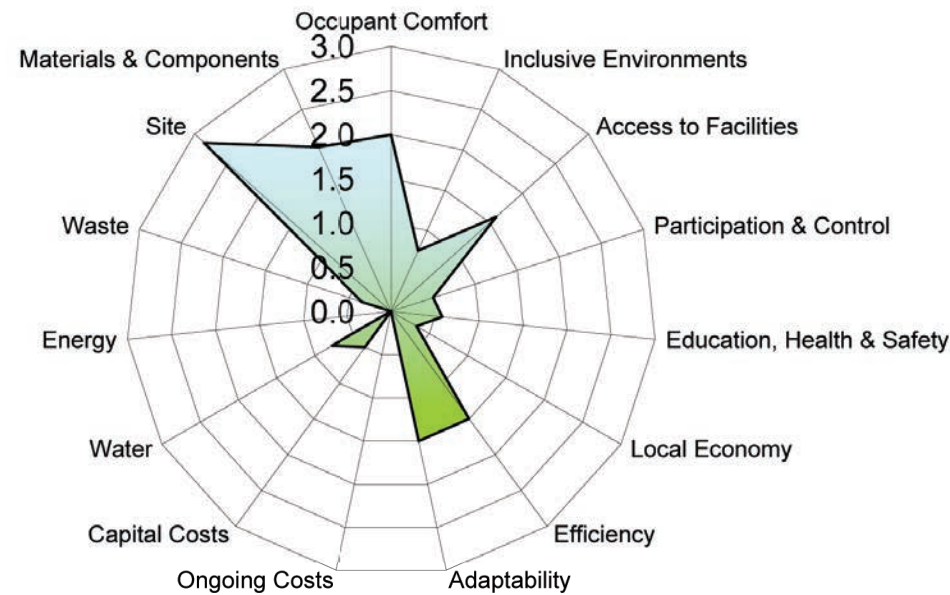

Opportunities:

The landscape can improve on the occupant comfort, water, energy, inclusive environments, Materials & components, education, health and safety. The site cannot improve on site related points.

Social 1.1

Economic 0.8

Environmental 1.2

Overall 1.0

Figure 211: Baseline SBAT/SITES rating tool (Author, 2014)

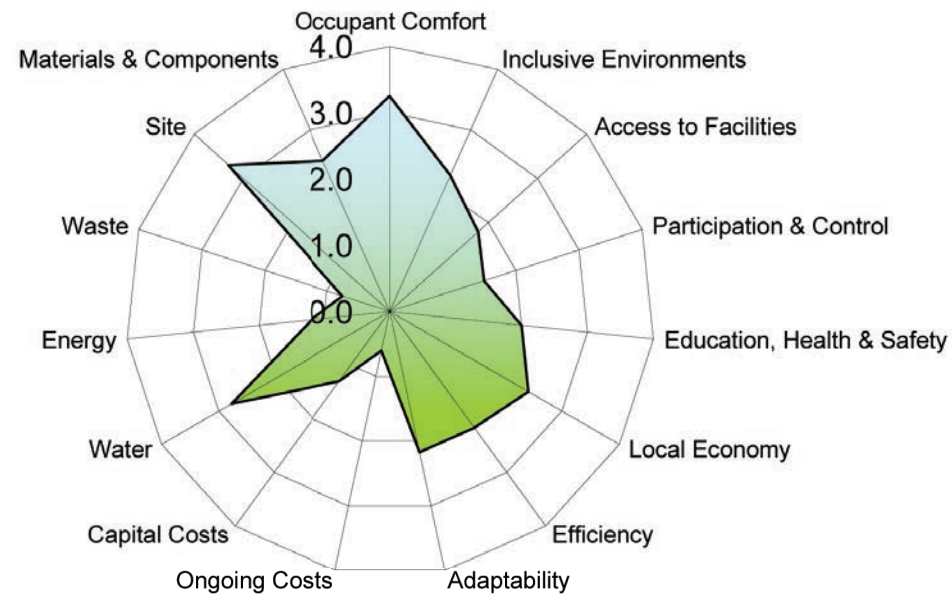

6.6.2 Version I

Criteria of changes is listed in Appendix 9.3.2

The proposal causes a decrease in the 'site' portion because the water front is located within 15m of the waters edge. Ongoing costs stay the same as it cannot be calculated.

Social 2.2

Economic 1.7

Environmental 2.1

Overall 2.0

Figure 212 Iteration 1 of SBAT/SITES rating tool (Author, 2014)

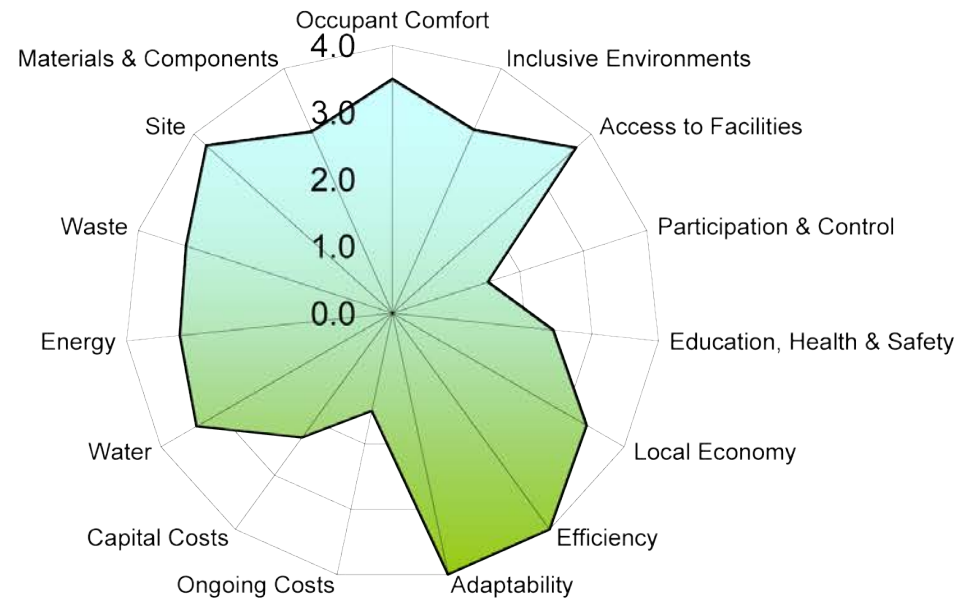

6.6.3.Version 2

Criteria of changes is listed in Appendix 8.3.2

Waste management is increased in the technification of the proposal. adaptability, efficiency increases. No community members were consulted. Ongoing costs cannot be calculated.

Social 2.8

Economic 3.0

Environmental 3.3

Overall 3.1

Figure 213: Iteration 1 of SBAT/SITES rating tool (Author, 2014)

7. FINAL PRODUCT

7.1 Final presentation

Contextual Map



Productive cell 2010 proposal

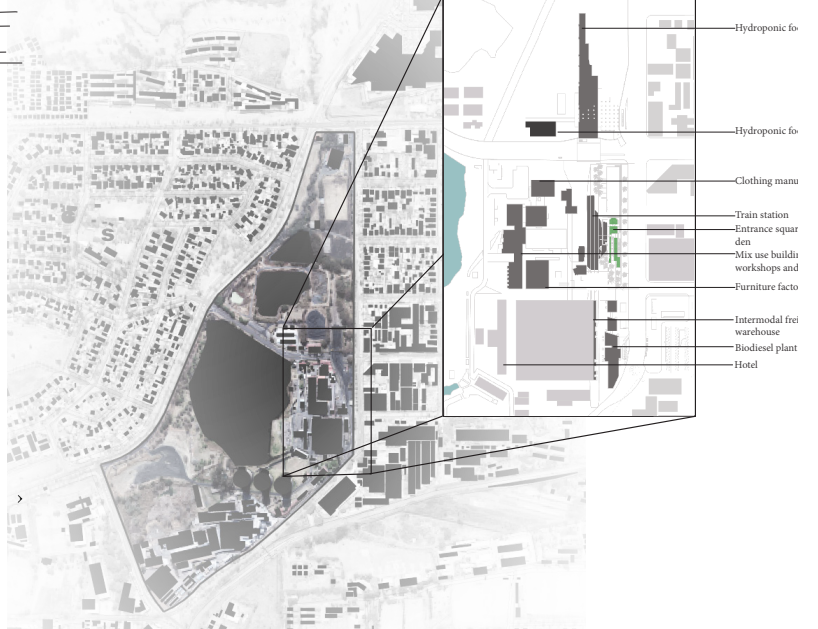

Real world problem
As illustrated in Figure 1, a higher population density occurs around Pretoria West in relation to the rest of Ekurhuleni's existing areas. The surrounding high-density residential areas Capital Park, Pretoria West, Kingsley Road and Kingsley Park (City of Pretoria, 2013). By 2015 more than two thirds of the world's population will be living in urban areas (Africa planning Association, 2014).
The city's resource demand is increasing and the carrying capacity of urban land is under strain. It is decreasing. There are initiatives and urban frameworks proposals that react to this resource demand, but they lack synergy and the maximization of systemic interactions, operations and productions.

Urban Problem
Pretoria West has an industrial character where industrial functions take preference in the urban and public realm. This results in a lack of quality public spaces, which disables communication from forming and high-quality and developing environmental stewardship.
Future visions for Pretoria West include the densification of residential areas, especially in Capital Park, West Park and Kingsley Road. This will further increase the population density in this area. The Pretoria West Power Station, being an industrial site, operated as an isolator. This isolation separated the site from the surrounding urban fabric.
There is an abrupt contrast between the large-scale industrial structures and the residential buildings adjacent to the site.

Architectural problem
This precinct (as proposed by the 2010 framework group) has become a simple out architectural expression. The thresholds between these expressions are not environments that have a positive psychological effect on the user. The built form West Power Station site within a rural property of 40ha, which is not integrated functions and urban fabric. The industrial character of the site leads to a diverse users and their perception of their ecological footprint.

C
O
N
T
E
X
T



West facing panoramic view of site

roponic food farm

roponic food farm

hing manufacturer

n station
ance square, sunken gar-
use building- Residential,
shops and restaurant
sture factory

modal freight storage
thouse
iesel plant
d

becomes a complement of diffe-
rents are not conducive to an
er. The built project of the Pretoria
is not integrated with the surrounding
land to a discussion between the

T H E O R E T I C A L P R E M I S E

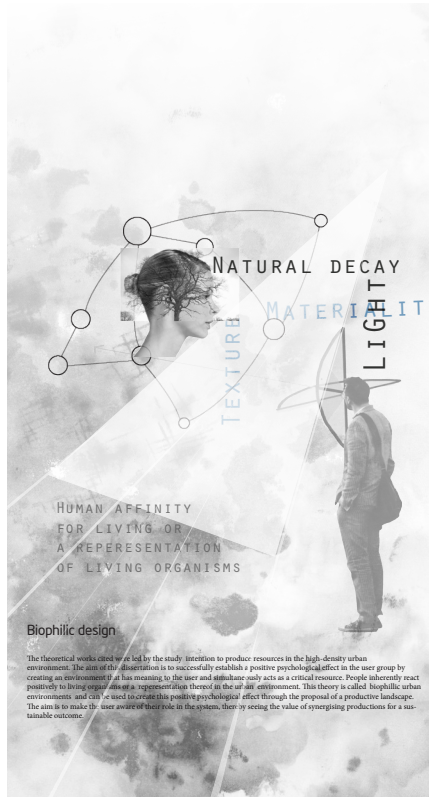

Figure 214: Panel 1 (Author, 2014)



Figure 215: Panel 4 (Author, 2014)

Upper level Sketch plan
1:200

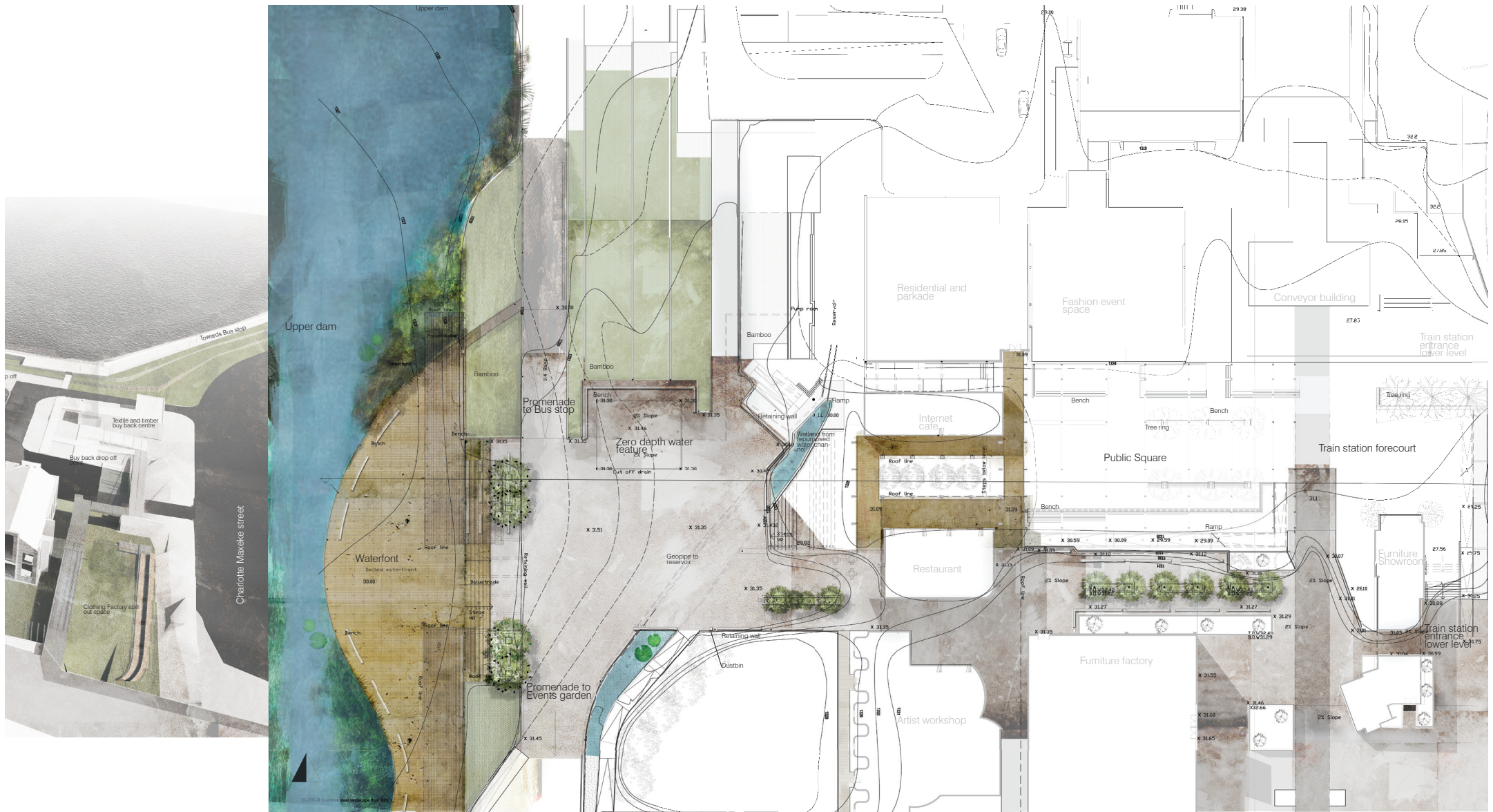
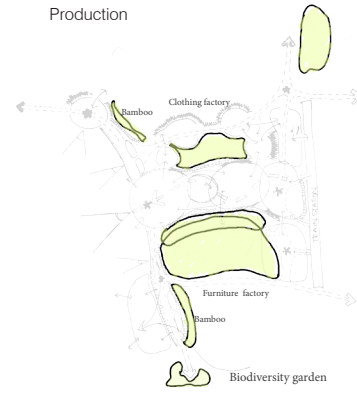
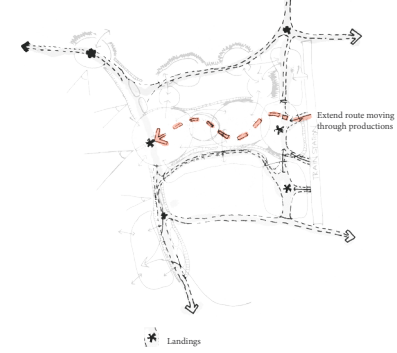

Figure 216: Panel 5 (Author, 2014)

Spatial relationship diagram



Movement through site



Public spaces

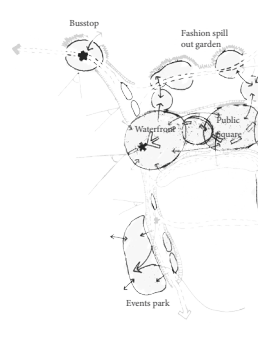

Section A-A
1:100



Figure 217: Panel 6 (Author, 2014)

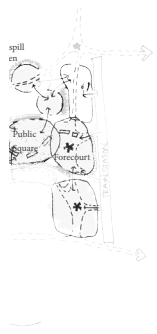

Biophilic elements



Combined spatial relationship diagram

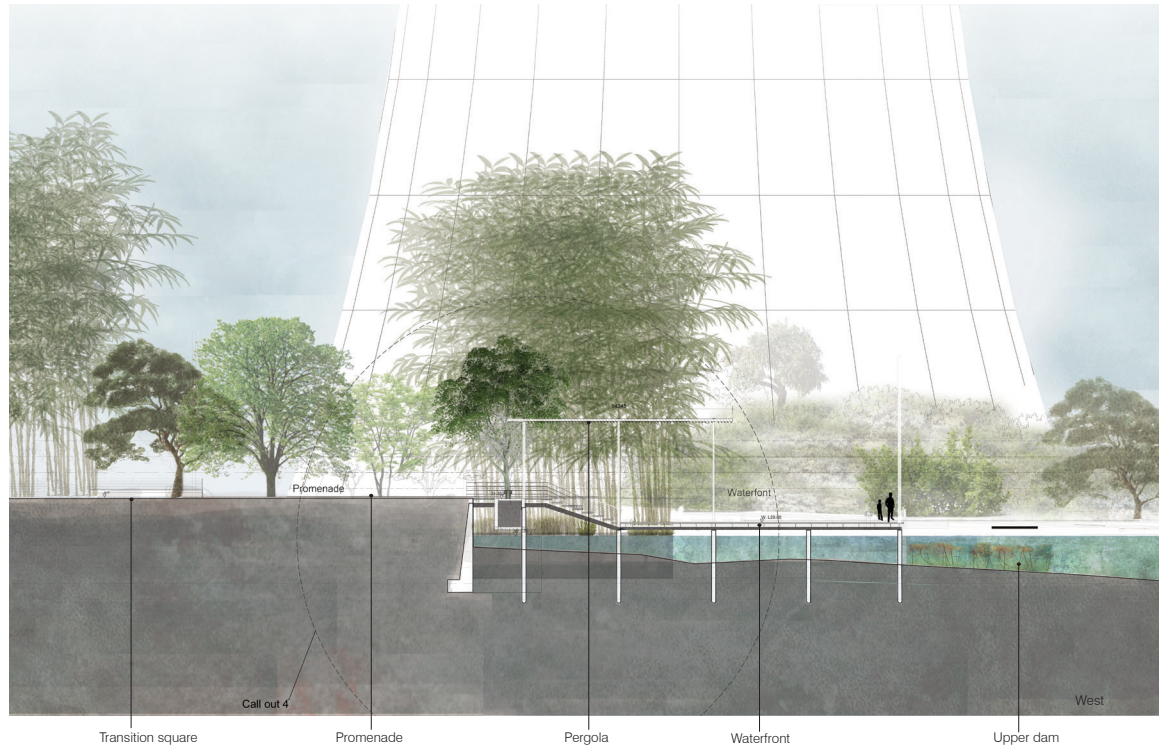
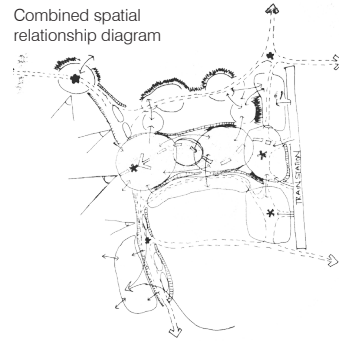

Lower level Sketch plan
1:200

Seasonal change of bamb

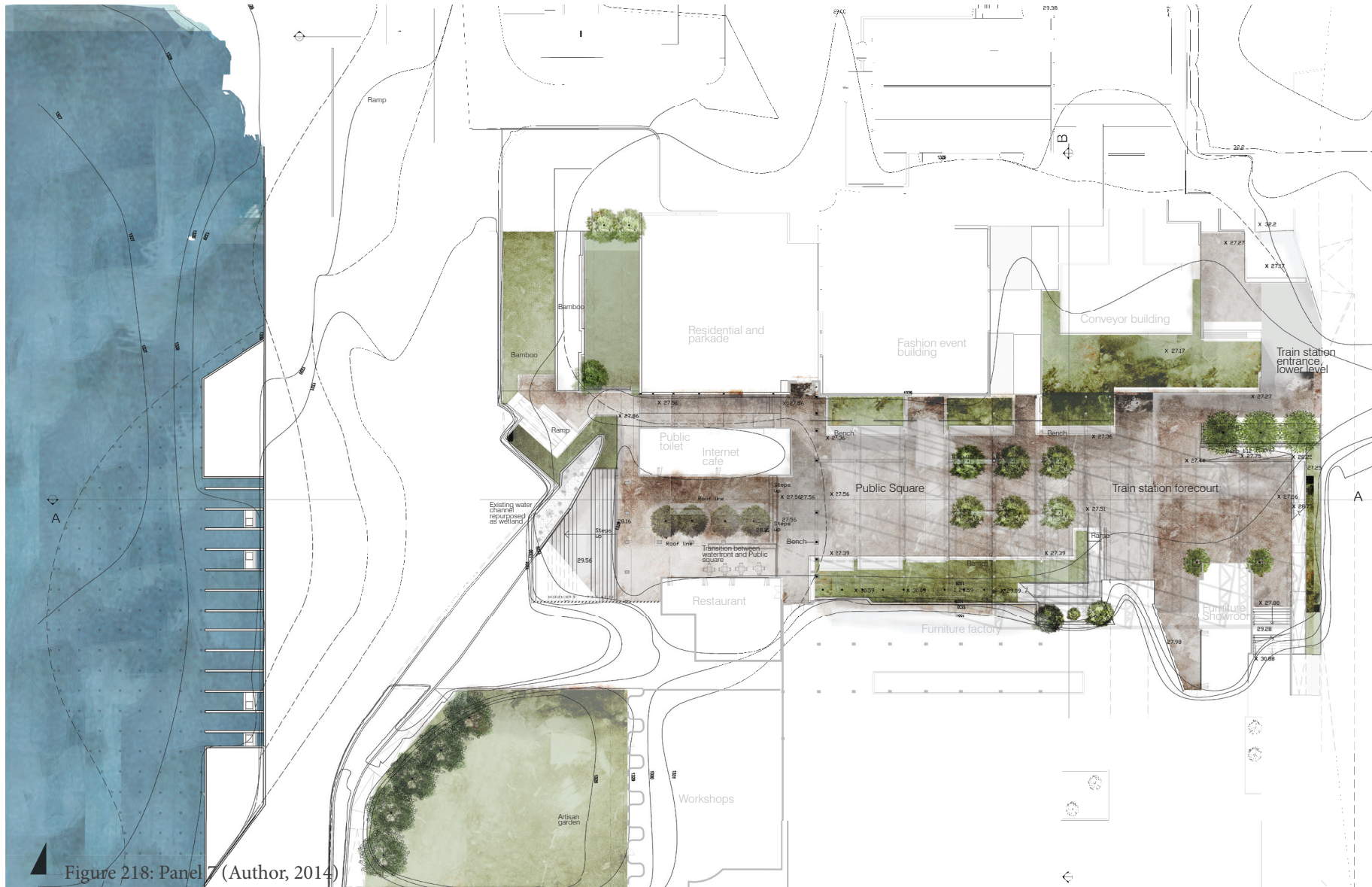

August E



Ramp B

Figure 218: Panel 7 (Author, 2014)

Bamboo



August Bamboo harvest



August- November drying, closed shutters

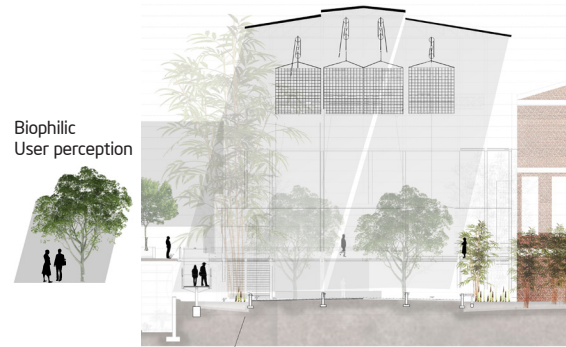

November - February Shutters and new culm growth

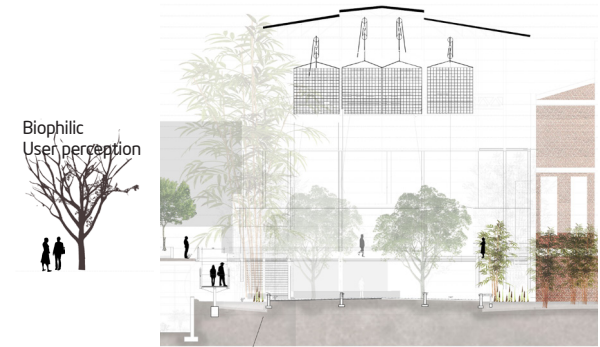

November - February - August open shutters



Figure 219: Panel 8 (Author, 2014)



198

West facing perspective of square with bamboo drying overhead

Detail 1

1:20

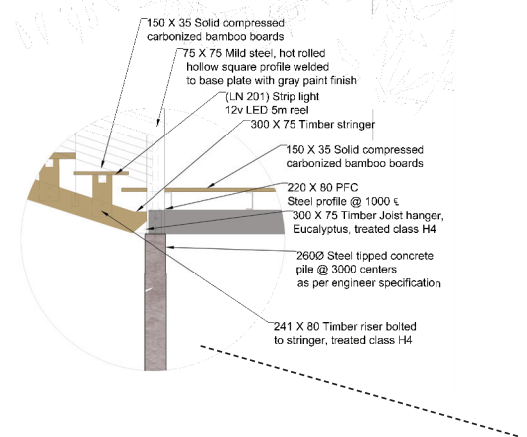

Detail 2

1:20

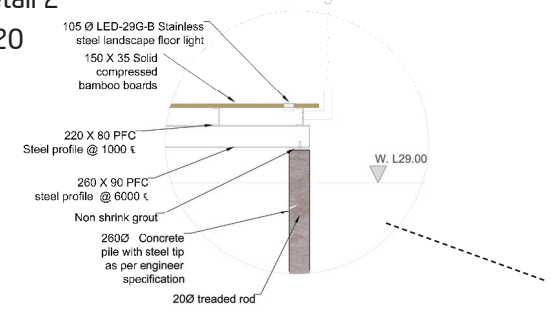

Callout 4: Waterfront

1:50

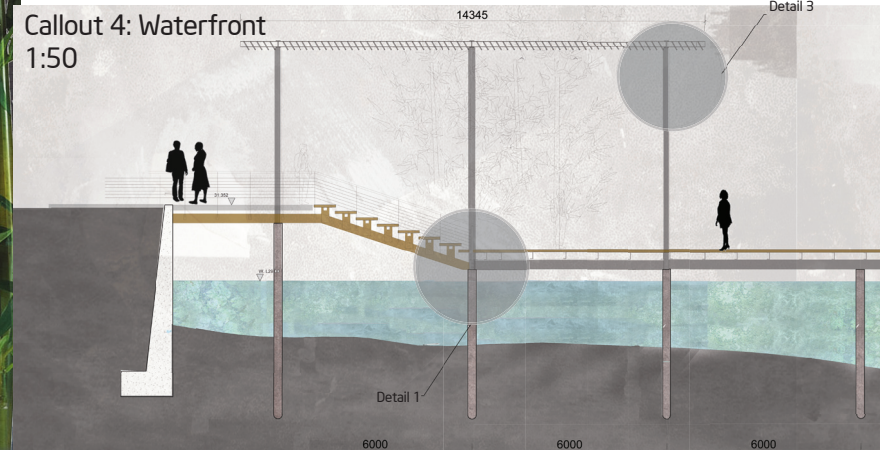

Detail 3
1:20

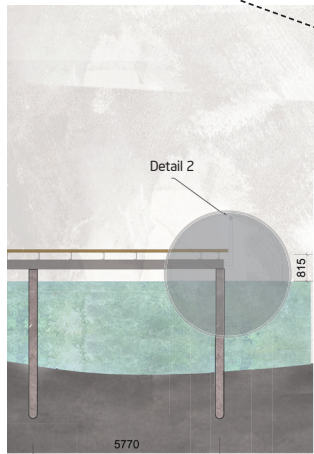
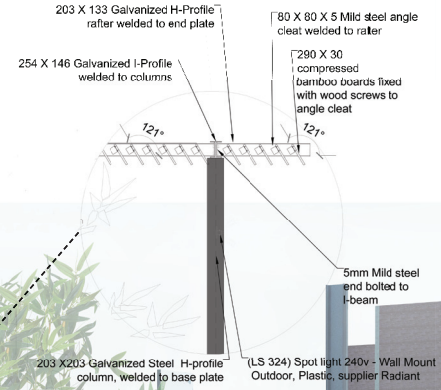
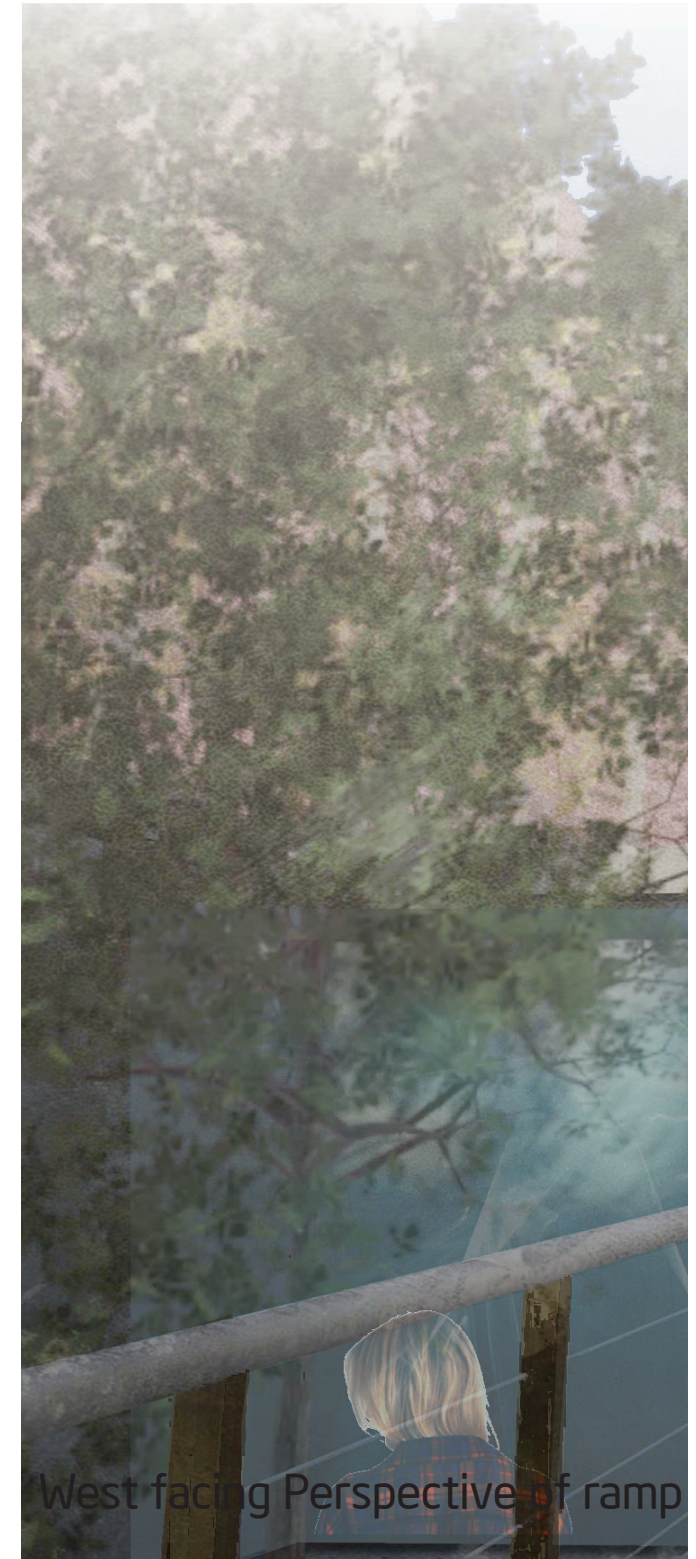

Figure 220: Panel 18 (Author, 2014)

Figure 221: Panel 15 (Author, 2014)





mp with Furniture factory facade on South and square on North

7.2 Model photographs



Figure 222: View west from lower level, trainstation (Author, 2014)



Figure 223: View North East from Upper dam (Author, 2014)

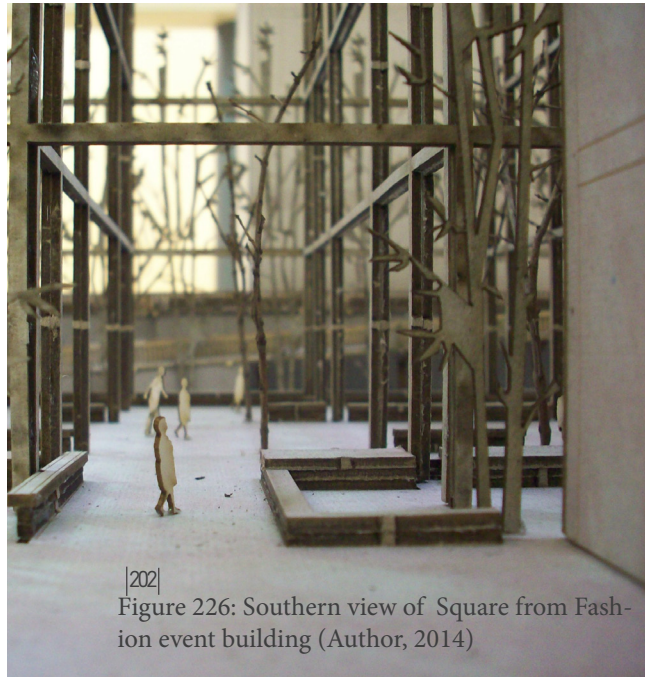

202
Figure 226: Southern view of Square from Fashion event building (Author, 2014)



Figure 227: North view of ramp against train station (Author, 2014)



Figure 228: North east view of Channel (Author, 2014)



Figure 224: View East from Upper dam (Author, 2014)

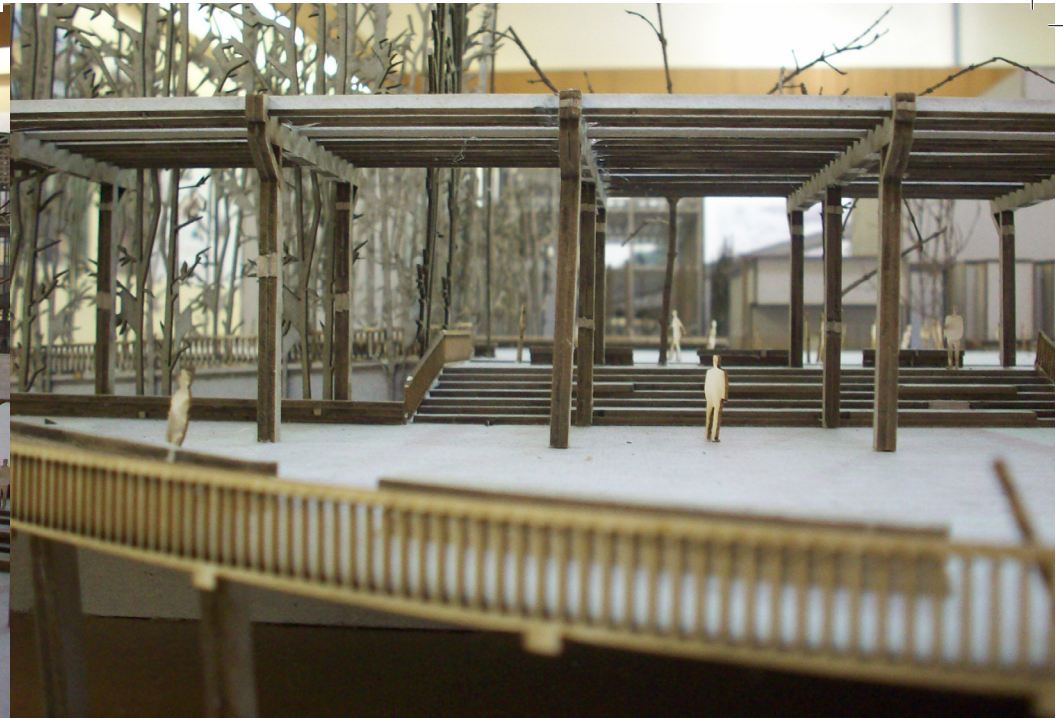

Figure 225: View East from Upper dam (Author, 2014)



Figure 229: View South from promenade (Author, 2014)



Figure 230: View North East from Upper dam (Author, 2014)

7.3: Conclusion

The intention of this dissertation was to transform the site from the mere commodity to an interactive productive landscape. The purpose was to educate the user on their role in the productive systems in effort to change the users mind sets about their ecological footprint. A diverse urban environment shared by man, production and nature purposes to reflect the relationship that man has with production and nature through applying theories on the insertion of meaning in the in the landscape.

The theory of biophilic urban environment provided non-obvious/obscure ways to affect the users sub conscious. This theory suggests that people have an inherent affiliation to nature, be it physical nature or a representation thereof in the urban environment.

The understanding and appreciation of the site is not only through sight but includes the holistic experience of the all the senses.

Meaning was attached to the site by locating productions in spaces that are most important to the users/ is mostly used. The complexity and decay that the site offers reflect characteristics of biophilic environments. The visibility of these elements is amplified by the simplistic forms and colours of the proposed scheme.

Natural systems change over time, as does the proposed productions on site. The public space is focused on exposing the user to the changes of the production and natural systems. Through following theoretical guidelines the proposed landscape will encourage meaning in the user.

8 . APPENDIX

8.1 Water calculations

Water calculations the watershed determined in chapter 6. the water budgets for the two dams on site is calculated separately.

8.1.1 Dam1. Large dam on southern side of the framework site

8.1.1.1 Calculation of dam size

The current volume of the dam is calculated and used as a baseline in the calculations. additionally the current volume in the dam is the amount of water needed for the dam's social function

Required Volume of the Dam	
m depth	Surface area
5 m deep	89675
Surface transformed to circle	
$89675 = \pi r^2$	
$168.9 = r$	
Volume of a cone	
$V = \pi r^2 \frac{h}{3}$	
$V = \pi (168.9)^2 \frac{5}{3}$	
$V = 179241 m^3$	
149368m3	

Table1: Volume of existing dam A (Author, 2014)

9.1.1.2 Yield Calculation

Pretoria Annual precipitation

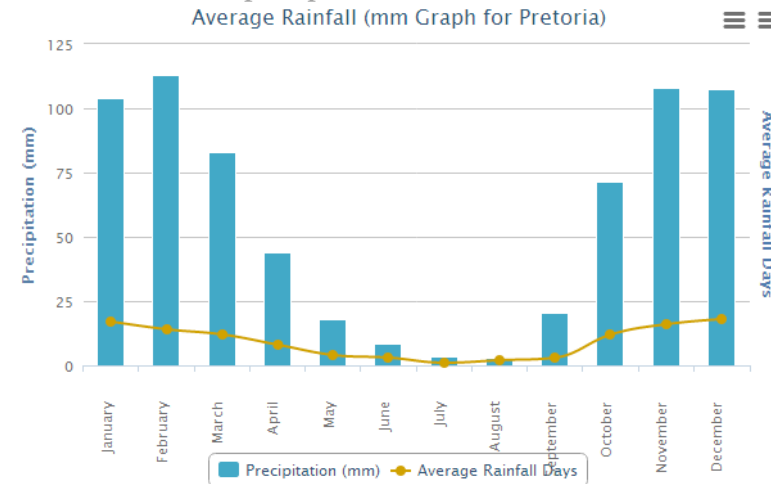

Figure 231: Pretoria annual precipitation (Weather world online, 2014)

Table 2: Yield calculation for Upper dam :
Watershed(Author, 2014)

Preliminary catchment area 801950
 The runoff coefficient light industrail and semi dense residential 0.6

Large catchment Yield			
Month	rainfall (mm)	m	yield (m ³)
Jan	136	0.136	65439
Feb	75	0.075	36088
March	82	0.082	39456
April	51	0.051	24540
May	13	0.013	6255
June	7	0.007	3368
July	3	0.003	1444
Aug	6	0.006	2887
Sept	22	0.022	10586
Oct	71	0.071	34163
Nov	98	0.098	47155
Dec	110	0.11	52929
	674		324310

Water shed indicated in chapter 6

Table 3: Yield calculation for Upper dam:
Building complex (Author, 2014)

Complex yield			
Month	Rainfall (mm)	m	Yield
Jan	136	0.136	3592
Feb	75	0.075	3941
March	82	0.082	2867
April	51	0.051	1535
May	13	0.013	621
June	7	0.007	105
July	3	0.003	35
Aug	6	0.006	70
Sept	22	0.022	698
Oct	71	0.071	2490
Nov	98	0.098	3770
Dec	110	0.11	3756

Grey water from hadn wash basins flow into construct-ed sub surface reservoir and is pumed into the water channel

Table 4: Yield calculation for upper dam: Grey water (Author, 2014)

Building	Monthly yield (l)
Fashion Building	720
Furniture building	7440
Train station	9920
Total	18080
total m3	18.08

Table 4: Yield calculation for Upper dam: Total grey water (Author, 2014)

Domestic yield	
Month	Yield
Jan	18.08
Feb	18.08
Mar	18.08
Apr	18.08
May	18.08
Jun	18.08
Jul	18.08
Aug	18.08
Sep	18.08
Oct	18.08
Nov	18.08
Dec	18.08

Table 5: Total yield(Author, 2014)

Total Yield	
Month	Yield
Jan	69049.08
Feb	40047.08
March	42341.08
April	26093.08
May	6894.08
June	3491.08
July	1497.08
Aug	2975.08
Sept	11302.08
Oct	36671.08
Nov	50943.08
Dec	56703.08

8.1.1.3 Demand Calculation

Bamboo irrigation depth calculations

Summer irrigation depth calculations:

Once a plant reaches maturity less water is required . in the first phase of the bamboo plant's life. The bamboo requires 4 L 4 times a week. An average of 7 bamboo culms are planted in a 1m² area. Therefore:

$$4l \times 7 \text{ plants} \times 4 \text{ times a week} \\ = 4 \times 7 \times 4 \\ = 112 \text{ L a week} \\ = 0.112 \text{ m}^3 \text{ per week}$$

Domestic demand

The buildings mentioned below all propose rainwaterharvestingtanks. the landscape cathment can sitll however supply for the remainder of the buildings water requirements

Fashion house :

The fashion house provides for a rain water harvesting tank the size of 80 000 L of water. The rain water harvested on an annual

basis is 409976 L The building's water usage on an annual basis is 925536L. The montly use is thus 77128L of water (van Biljon, 2010). The fashion house requires an additional 80 m³ of water for hand wash basins.

Train station:

The trainstation requires an annual 355 m³ of water on from the landscape catchment, in addition to the building's 354 m³ storage facility (Joubert, 2010).

Furniture factory:

The building retrofitted an existing oil tank for water storage of 95 832 L (Pauw, 2014). The stored water is used for the building's toilets. The landscape can supplies an additional 882m³ of water to the furniture factory annually for hand wash basins. (Pauw, 2010).

Total domestic use:

The total monthly domestic use amounts to 109.75m³ .

Loss of water to evaporation:

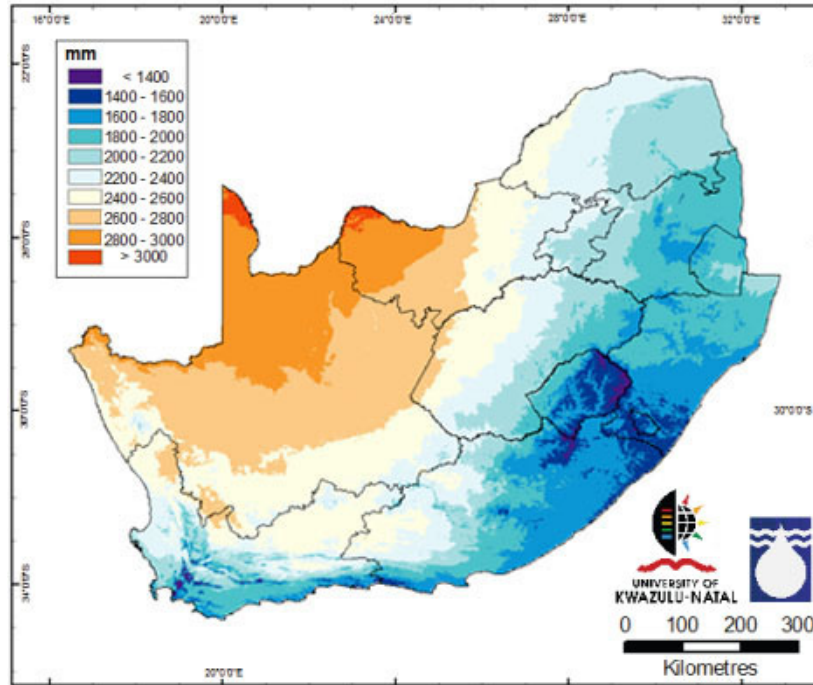

Figure 232: South African evaporation rates (mm/a) (Schulze et al., 2008)

Table 6: Demand calculation for Upper dam (Author, 2014)

Monthly Evaporation rate Summer	0.16
Monthly Evaporation rate Winter	0.12

Water Demand Calculation

Month	Irrigation demand (m ³)	Domestic demand (m ³)	Evaporation
Jan	3082	1317	14348
Feb	3082	1317	14348
March	3082	1317	14348
April	3082	1317	10761
May	3082	1317	10761
June	1856	1317	10761
July	1856	1317	10761
Aug	1856	1317	10761
Sept	1856	1317	10761
Oct	1856	1317	14348
Nov	3082	1317	14348
Dec	3082	1317	14348
Annual avg	30854	15804	150654

8.1.1.4 Irrigation type

Drip irrigation, protected by a mulch layer and a root barrier is proposed for both the bamboo and the endemic plants on site to minimise evaporation.

Table 7: Total demand for Upper dam (Author, 2014)

Total demand
18747
18747
18747
15160
15160
13934
13934
13934
13934
17521
18747
18747
197312

8.1.1.4 Water budget.

The volume calculated in 8.1.1.1 is used as a baseline for water harvesting. The baseline is calculated from the driest month of the year, August. The dam is too small for the amount of water that it receives in the rainy season. The dam overflows to the second dam. when it reaches a 149368m³. Water is pumped back in dry months from the second dam to keep the top dam full.

Table 8: Water budget balancing for Upper dam (Author, 2014)

Water budget /catchmentYear 1							
month	yield	total water demand (m ³)	monthly balance	volume of water in re	Capacity	Pumped Back	Overflow
Jan	69049.08	18747	50302	199670	149368	0	50302
Feb	40047.08	18747	21300	170668	149368	0	21300
March	42341.08	18747	23594	172962	149368	0	23594
April	26093.08	15160	10933	160301	149368	0	10933
May	6894.08	15160	-8266	149368	149368	8266	0
June	3491.08	13934	-10443	149368	149368	10443	0
July	1497.08	13934	-12437	149368	149368	12437	0
Aug	2975.08	13934	-10959	138409	149368	10959	0
Sept	11302.08	13934	-2632	135777	149368	2632	0
Oct	36671.08	17521	19150	154927	149368	0	5559
Nov	50943.08	18747	32196	181564	149368	0	32196
Dec	56703.08	18747	37956	187324	149368	0	37956
annual Total	348007	197312	150694	1949706		44737	181840

8.1.1 Lower dam. Smaller dam on northern side of framework site

The yield for this dam includes the overflow from the top dam.

Table 9: Calculation of volume of Lower dam (Author, 2014)

Volume of secondary dam

M depth	surface area
4	18784
Surface transformed to circle	
$18784 = \pi r^2$	
$77 = r$	
Volume of a cone	
$V = \pi r^2 \frac{h}{3}$	
$V = \pi (77)^2 \frac{4}{3}$	
$V = \pi (77)^2 \frac{4}{3}$	
$V = 24835.33$	

Table 10: Yield calculation for dam B (Author, 2014)

Yield			
Month	Overflow	Hydroponic food farm	Total
jan	50302	322	50624
feb	21300	322	21622
mar	23594	322	23916
apr	10933	322	11255
may	0	322	322
jun	0	322	322
jul	0	322	322
aug	0	322	322
sep	0	322	322
oct	5559	322	5881
nov	32196	322	32518
dec	37956	322	38278

Table 11: Demand calculation for Lower dam

Demand			
Month	Pumped to large dam	Evaporation	Total
Jan	0	3005.44	3005.44
Feb	0	3005.44	3005.44
Mar	0	3005.44	3005.44
Apr	0	2254.08	2254.08
May	8284	2254.08	10538.08
Jun	10461	2254.08	12715.08
Jul	12455	2254.08	14709.08
Aug	10977	2254.08	13231.08
Sep	2650	2254.08	4904.08
Oct	0	3005.44	3005.44
Nov	0	3005.44	3005.44
Dec	0	3005.44	3005.44

Table 7: Water budget balancing for Lower dam (Author, 2014)

New volume of reservoir 38000
 Budget

Month	Yield	Overflow	Demand	Balance	Volume in reservoir
jan	50624	12624	3005.44	34994.56	26000
feb	21622	0	3005.44	18616.56	26000
mar	23916	0	3005.44	20910.56	26000
apr	11255	0	2254.08	9000.92	38000
may	322	0	10538.08	-10216.08	27783.92
jun	322	0	12715.08	-12393.08	15390.84
jul	322	0	14709.08	-14387.08	1003.76
aug	322	0	13231.08	-12909.08	24835
sep	322	0	4904.08	-4582.08	20252.92
oct	5881	0	3005.44	2875.56	23128.48
nov	32518	0	3005.44	29512.56	26000
dec	38278	278	3005.44	34994.56	26000

8.2 Economic Module

A commercially available module supplied by Bamboo warehouse was chosen as a benchmark to determine the economic viability of the bamboo crop on a master plan level.

8.2.1 Module information

Dimensions and volume:
2440x1220x40 (LxWxH)

Thus the volume of the module is:
 $V = 0.119 \text{ m}^3$

The module described above has a retail price of R 2 850.00 (Bamboo Warehouse, 2014)

8.2.2 Number of bamboo culms required to manufacture one module

Volume per culm

The average size of a bamboo culm is 21 000 x 150 (Height x surface diameter), two thirds of which cannot be utilised due to the hollow nature of the culm. In addition 40 % of the usable material is

wasted during the manufacturing and processing.

The volume of one culm is:
 $V = (\Pi/4) \times (0.15)^2 \times 21 \times 0.33 \times 0.6$
 $V = 0.0734 \text{ m}^3$

Number of culms required per module:
 $= 0.98 \text{ m}^3 / 0.119 \text{ m}^3$
 $= 8 \text{ modules per culm}$

8.2.2 Master plan Turnover

The area allocated to the cultivation of bamboo in the master plan is 8254 m². Bamboo is planted at 400 mm centres which equates to an average of 8 culms per square meter of planted area.

The total number of culms in the master plan :
 $= 8 \times 8284$
 $= 66 272 \text{ culms}$

Number of modules that can be plan can produce:
 $= 66 272 / 1.62$
 $= 410304 \text{ modules}$

The turnover generated by the sale of one module is R 2 850.00

Thus the turnover generated from the sale of 41 304 modules is:
 $= 41 304 \times R 2 850$
 $= R 117 716 400.00$ over a three year cycle
Therefore the annual turnover is
 $= R 117 716 400.00 / 3$
 $= R 39 238 800.00$ per year (excluding manufacturing costs, etc.)

8.2.3 Production and manufacturing costs

Labour:
Workers conduct harvesting and planting and manufacture therefore they are employed fulltime. Currently the minimum wage for an artisan for a 45-hour week is R 5376.00 (MyWage, 2014)
For five artisans
 $= 5 \times 5376$
 $= R 26 880$ per month
 $= R 322 560$ per year

Tools and Maintenance cost:

Tools:
Cutting tools: R 50 000.00
Splitters: R 20 000.00
Other: R 30 000.00
Total: R 100 000.00
per year

Maintenance:
Sundry R 40 000.00
Manager salary: R 240 000.00
Total R 280 000.00
per year

Thus the total labour, tools and maintenance cost per year is

R 702 560.00

Overall Profit:

Turnover R 39 238 800.00
Expenses R 702 566.00
Profit R 38 536 240.00

However, it must be noted that the profit above does not take into consideration any repayments on capital expenditure, marketing and sales as well as the use of utilities. It purely indicates that the cultivation of bamboo is economically feasible.

8.3 SBAT/SSI inputs

8.3.1 Baseline

9.3.1.1 Social

Criteria	Indicative performance measure	Measured	Points	Not NB for Landscapes Quantified modelled or measured performance data
SO 1 Occupant Comfort		Explanatory notes		2.0
SO 1.1	Daylighting	% of occupied spaces that are within distance 2H from window, where H is the height of the window or where there is good daylight from skylights	0	0.0
SO 1.2	Ventilation	% of occupied spaces have equivalent of opening window area equivalent to 10% of floor area or adequate mechanical system, with unpolluted air source	0	0.0
SO 1.3	Noise	% of occupied spaces where external/internal/reverberation noise does not impinge on normal conversation (50dbA)	50	0.5
SO 1.5	Thermal comfort	Temperature of occupied space does not exceed 28 or go below 19°C for less than 5 days per year (100%)	10	0.1
SO 1.5	Views	% of occupied space that is 6m from an external window (not a skylight) with a view	0	0.0
	Views	provide views of vegetation and quiet outdoor spaces for mental restoration (refer to credit 6.7 of SSI for percentage allocation)	50	0.5
	social interaction	provide outdoor spaces for social interaction (refer to credit 6.8 of SSI for percentage allocation)	50	0.5
SO 2 Inclusive Environment		Explanatory notes		0.8
SO 2.1	Public Transport	% of landscape (s) within 400m of disabled accessible (20%) and affordable (80%) public transport	20	0.2
SO 2.2	Information	Comprehensive signage provided (50%), Signage high contrast, clear print signage in appropriate locations and language(s) / use of understandable symbols / manned reception at all entrances (50%)	0	0.0
SO 2.3	Space	% of occupied spaces that are accessible to ambulant disabled / wheelchair users	20	0.2
SO 2.4	Toilets	% of occupied space with fully accessible toilets within 50m along easily accessible route	20	0.2
SO 2.5	Fittings & Furniture	% of commonly used furniture and fittings (reception desk, kitchenette, auditorium) fully accessible	0	0.0
SO 3 Access to Facilities		Explanatory notes		1.6
SO 3.1	Children	All users can walk (100%) / use public transport (50%) to get to their childrens' schools and creches	10	0.1
SO 3.2	Banking	All users can walk (100%) / use public transport (50%) to get to banking facilities	10	0.1
SO 3.3	Retail	All users can walk (100%) / use public transport (50%) to get to food retail	50	0.5
SO 3.4	Communication	All users can walk (100%) / use public transport (50%) to get to communication facilities (post/telephone/internet)	10	0.1
SO 3.5	Exercise	All users can walk (100%) / use public transport (50%) to get to recreation/exercise facilities	80	0.8
SO 4 Participation & Control		Explanatory notes		0.5
SO 4.1	Environmental control	% of occupied space able to control their thermal environment (adjacent to openable windows/thermal controls)	0	0.0
SO 4.2	Lighting control	% of occupied space able to control their light (adjacent to controllable blinds etc/local lighting control)	0	0.0
SO 4.3	Social spaces	Social informal meeting spaces (parks / staff canteens / cafes) provided locally (within 400m) (100%)	0	0.0
SO 4.4	Sharing facilities	5% or more of facilities shared with other users / organisations on a weekly basis (100%)	20	0.2
SO 4.5	User group	Users actively involved in the design process (50%) / Active and representative management user group (50%)(Refer to Credit 2.3 SSI for percentage allocation)	0	0.0
SO 5 Education, Health & Safety		Explanatory notes		0.6
SO 5.1	Education	Two percent or more space/facilities available for education (seminar rooms / reading / libraries) per occupied space (75%). Construction training provided on site (25%)(refer to credit 6.3 of SSI for credit allocation)	0	0.0
SO 5.2	Safety	All well used routes in and in landscape well lit (25%), all routes in and around landscape is visually supervised (25%), secure perimeter and access control (50%), No crime (100%)(refer to Credit 6.5 of SSI for percentage allocation)	0	0.0
SO 5.3	Awareness	% of users who can access information on health & safety issues (ie HIV/AIDS), training and employment opportunities easily (posters/personnel/intranet site)	0	0.0
SO 5.4	Materials	All materials/components used have no negative effects on indoor air quality (100%)	0	0.0
SO 5.5	Accidents	Process in place for recording all occupational accidents and diseases and addressing these	0	0.0
SO 5.6	Physical activity	Provide opportunities for outdoor physical activity(refer to credit 6.6 of SSI for percentage allocations)	0	0.0
SO 5.7	Historical places	protect and maintain cultural and historical places(refer to credit 6.4 in SSI for percentage allocation)	70.0	0.7

		changed criteria to meet landscape requirements		
Criteria	Indicative performance measure		Measured	Points
EC 1	Local economy			0.3
		<u>Explanatory notes</u>		
EC 1.1	Local contractors	% value of the landscape constructed by local (within 50km) small (employees<20) contractors	10	0.1
EC 1.2	Local materials	% of materials (sand, bricks, blocks, roofing material) sourced from within 50km	10	0.1
EC 1.3	Local components	% of components (windows, doors etc) made locally (in the country)	0	0.0
EC 1.4	Local furniture/fittings	% of furniture and fittings made locally (in the country)	10	0.1
EC 1.5	Maintenance	% of maintenance and repairs by value that can, and are undertaken, by local contractors (within 50km)	10	0.1
	Equitable site development	Promote equitable site development(refer to credit 6.1 of SSI for percentage allocation)	0	0.0
	Equitable site use	Promote equitable site use (refer to credit 6.2 of SSI for percentage allocation)	0	0.0
EC 2	Efficiency			1.5
		<u>Explanatory notes</u>		
EC 2.1	Capacity	% capacity of landscape used on a daily basis (actual number of users / number of users at full capacity*100)	60	0.6
EC 2.2	Occupancy	% of time landscape is occupied and used (actual average number of hours used / all potential hours landscape could be used (24) *100)	20	0.2
EC 2.3	Space per occupant	Space provision per user not more than 10% above national average for building type (100%)	0	0.0
EC 2.4	Communication	Site/building has access to internet and telephone (100%), telephone only (50%)	0	0.0
EC 2.5	Material & Components	Landscape design coordinated with material / component sizes in order to minimise wastage. Floor (50%), other built elements (50%)	10	0.1
EC 3	Adaptability			0.5
		<u>Explanatory notes</u>		
EC 3.1	Vertical heights	% of spaces that have a floor to ceiling height of 3000mm or more	0	0.0
EC 3.2	External space	Design facilitates flexible space use (100%) landscape can be used in more than one way	10	0.1
EC 3.3	Internal partition	Non loadbearing internal partitions that can be easily adapted (loose partitioning (100%), studwall (50%), masonry (25%))	0	0.0
EC 3.4	Modular planning	Building with modular structure, envelope (fenestration) & services allowing easy internal adaptaptation (100%)	0	0.0
EC 3.5	Furniture	Modular, limited variety furniture - can be easily configured for different uses (100%)	0	0.0
	Deconstruction	Landscape intervention can easily be reversed/ deconstructed	10	0.1
EC 4	Ongoing costs			0.0
		<u>Explanatory notes</u>		
EC 4.1	Induction	All new users receive induction training on landscape systems (50%), Detailed landscape user manual (50%)	0	0.0
EC4.2	Consumption & waste	% of users exposed on a monthly basis to building performance figures (water (25%), electricity (25%), waste (25%), accidents (25%))	0	0.0
EC 4.2	Metering	Easily monitored localised metering system for water (50%) and energy (50%)	0	0.0
EC4.3	Maintenance & Cleaning	% of landscape that can be cleaned and maintained easily and safely using simple equipment and local non-hazardous materials	0	0.0
	performance of design	Monitor performance of sustainable design(refer to credit 9.1 of SSI for percentage allocation)	0	0.0
SO 4.5	Procurement	% of value of all materials/equipment used in the landscape on a daily basis supplied by local (within the country) manufacturers	0	0.0
EC 5	Capital Costs			0.5
		<u>Explanatory notes</u>		
EC 5.1	Local need	Five percent capital cost allocated to address urgent local issues (employment, training etc) during construction process (100%)	0	0.0
EC5.2	Procurement	Tender / construction packaged to ensure involvement of small local contractors/manufacturers (100%)	0	0.0
EC 5.3	Building costs	Capital cost not more than fifteen % above national average landscape costs for the landscape type (100%)	0	0.0
EC5.4	Technology	3% or more of capital costs allocated to new sustainable/indigenous technology (100%)	0	0.0
EC 5.5	Existing Buildings	Existing urban environments reused (100%)	50	0.5

9.3.1.2 Economic

Building Performance - Environmental

		criteria changed to meet landscape requirements indicated in red	
Criteria	Indicative performance measure	Measured	Points
EN 1	Water	<u>Explanatory notes</u>	0.8
EN 1.1	Rainwater	% of water consumed sourced from rainwater harvested on site	20 0.2
EN 1.2	Water use	% of equipment (taps, washing machines, urinals showerheads) that are water efficient	10 0.1
EN 1.3	Runoff	% of carparking, paths, roads and roofs that have absorbant/semi absorbant/permeable surfaces (grassed/thatched/looselaid paving/ absorbant materials)	10 0.1
EN 1.4	Grey water	% of water from washing/relatively clean processes recycled and reused	0 0.0
EN 1.5	Planting	% of planting (other than food gardens) on site with low / appropriate water requirements	0 0.0
EN 1.6	Reduce potable water	Reduce potable water for landscape irrigation by 75 % or more from established baseline(Refer to credit 3.2 SSI for	0 0.0
EN 1.7	Protect on-Site Water	Protect and enhance on-site water resources and receiving water quality (refer to credit 3.6 SSI for percentage	0 0.0
EN 1.8	Storm water Amenity	Design rainwater/storm water features in an aesthetically pleasing way(Refer to credit 3.7 SSI for percentage	0 0.0
EN 1.9	Water Features	Only applicable to designs with water features(refer to EN 1.9 on criteria notes of SBAT excel spreadsheet)	100 1.0
EN 1.10	Natural Water masses	Only applicable to sites with river, wetlands and shoreline buffers(refer to EN 1.10 on criteria notes tab of SBAT excel spreadsheet)	0 0.0
EN 1.11	Rehabilitate lost natural water	Only applicable to sites which have lost streams, wetlands and shorelines (Refer to EN 1.11 on criteria notes tab Of SBAT Excel spreadsheet)	0 0.0
EN 2	Energy	<u>Explanatory notes</u>	0.0
EN 2.2	Ventilation	% of building ventilation requirements met through natural / passive ventilation	0 0.0
EN 2.3	Heating & Cooling	% of occupied space which relies solely on passive environmental control (no or minimal energy consumption)	0 0.0
EN 2.4	Appliances & fittings	% of appliances / lighting fixtures that are classed as highly energy efficient (ie energy star rating)	0 0.0
EN 2.5	Renewable energy	% of landscape energy requirements met from renewable sources(refer to credit 8.5 of SSI for percentage	0 0.0
	vegetation to minimize outdoor energy	use vegetation to minimize buildings heating and cooling requirements(refer to credit 4.10&4.11 of SSI for	0 0.0
	car emission	Reduce outdoor energy consumption for all landscape operations(refer to credit 8.4 of SSI for percentage allocation)	0 0.0
		Reduce emissions and promote the use of fuel efficient vehicles(refer to credit 8.8 of SSI for percentage allocation)	0 0.0
EN 3	Waste	<u>Explanatory notes</u>	0.4
EN 3.1	Toxic waste	% of toxic waste (batteries, ink cartridges, flourescent lamps) recycled	0 0.0
EN 3.2	Organic waste	% of organic waste recycled	0 0.0
EN 3.3	Inorganic waste	% of inorganic waste recycled.	0 0.0
EN 3.4	Sewerage	% of sewerage recycled on site	0 0.0
EN 3.5	Construction waste	% of damaged building materials / waste developed in construction recycled on site	10 0.1
	light pollution	Reduce light pollution (refer to credit 6.9 of SSI for allocation oof percentage)	60 0.6
	greenhouse gas	Minimize greenhouse gas emissions during construction(refer to credit 7.6 of SSI for percentage allocations)	0 0.0
	maintenance waste	Recycle organic matter generated during Maintenance (refer to credit 8.3 in SSI for percentage allocation)	0 0.0
	Tabacco	minimize exposure to environmental tabacco smoke(refer to credit 8.6 of SSI	0 0.0
	greenhouse gasses:	minimize generation of greenhouse gasses and exposure to localized air pollutants during maintenance activities(0 0.0
EN 4	Site	<u>Explanatory notes</u>	2.9
EN 4.1	Brownfield site	% of proposed site already disturbed / brownfield (previously developed)(Refer to credit 1.5 SSI for percentage	20 0.2
EN 4.2	Neighbouring buildings	No neighbouring buildings negatively affected (access to sunlight, daylight, ventilation) (100%)	0 0.0
EN 4.3	Vegetation	% of area of area covered in vegetation (include green roofs, internal planting) relative to whole site	30 0.3
EN 4.4	Food gardens	Food gardens on site (100%)	60 0.6
EN 4.5	Landscape inputs	% of landscape that does not require mechanical equipment (ie lawn cutting) and or artificial inputs such as weed killers and pesticides	100 1.0
EN 2.1	Location	% of users who walk / cycle / use public transport to commute to the precinct (refer to credit 1.7 SSI for percentage	80 0.8
	Soil disturbance	Minimize soil disturbance in design and construction (refer to credit 4.4 of SSI for percentage allocation	100 1.0
	Special status	Preserve all vegetation designated as special status (Refer to credit 4.5 of SSI for percentage allocation)	90 0.9
	Biomass	Preserve and restore appropriate biomass on site(refer to credit 4.6 of SSI for percentage allocation)	50 0.5
	restore soils	restore soils disturbed by previous development(refer to credit 7.3 of SSI for percentage allocation)	40 0.4
EN 5	Materials & Componer	<u>Explanatory notes</u>	2.0
EN 5.1	Embodied energy	Materials with high embodied energy (aluminium,plastics) make up less than 1% of weight of implemented	50 0.5
EN 5.2	Material sources	% of materials and components by volume from grown sources (animal/plant)(refer to Credit 5.10of SSI for	50 0.5
EN 5.3	Ozone depletion	No materials and components used requiring ozone depleting processes (100%)(refer to credit 5.8)	0 0.0
EN 5.4	Recycled / reuse	% of materials and components (by weight) reused / from recycled sources (refer to credit 5.5 of SSI forpercentage	0 0.0
EN 5.5	Construction process	Volume / area of site disturbed during construction less than 2X area of new landscape (100%)	10 0.1

8.3.2.1 Social

Criteria unchanged by proposal in grey

Changed criteria to meet landscape requirements indicated in red

Criteria	Indicative performance measure	Measured	Points	Point value description
				Not NB for Landscapes
Occupant Comfort			3.3	http://greenbuilding.ca/
Daylighting	% of occupied spaces that are within distance 2H from window, where H is the height of the window or where there is good daylight from skylights	0	0.0	
Ventilation	% of occupied spaces have equivalent of opening window area equivalent to 10% of floor area or adequate mechanical system, with unpolluted air source	0	0.0	
Noise	% of occupied spaces where external/internal/reverberation noise does not impinge on normal conversation (50dba)	50	0.5	
Thermal comfort	Temperature of occupied space does not exceed 28 or go below 19°C for less than 5 days per year (100%)	50	0.5	Planting and shade structures provides shade in sunny areas but permanently shady areas can not be altered
Views	% of occupied space that is 6m from an external window (not a skylight) with a view	0	0.0	
Views	provide views of vegetation and quiet outdoor spaces for mental restoration (refer to credit 6.7 of SSI for percentage allocation)	80	0.8	Water front and look out point
social interaction	provide outdoor spaces for social interaction (refer to credit 6.8 of SSI for percentage allocation)	80	0.8	Zero depth water feature, pleasant seating spaces
Inclusive Environment			2.3	
Public Transport	% of landscape (s) within 400m of disabled accessible (20%) and affordable (80%) public transport	20	0.2	Same as before
Information	Comprehensive signage provided (50%), Signage high contrast, clear print signage in appropriate locations and language(s) / use of understandable symbols / manned reception at all entrances (50%)	50	0.5	Comprehensive signage
Space	% of occupied spaces that are accessible to ambulant disabled / wheelchair users	90	0.9	3 additional ramps to level 0 is provided.
Toilets	% of occupied space with fully accessible toilets within 50m along easily accessible route	20	0.2	
Fittings & Furniture	% of commonly used furniture and fittings (reception desk, kitchenette, auditorium) fully accessible	0	0.0	
Access to Facilities			1.8	
Children	All users can walk (100%) / use public transport (50%) to get to their childrens' schools and creches	10	0.1	
Banking	All users can walk (100%) / use public transport (50%) to get to banking facilities	10	0.1	
Retail	All users can walk (100%) / use public transport (50%) to get to food retail	70	0.7	
Communication	All users can walk (100%) / use public transport (50%) to get to communication facilities (post/telephone/internet)	10	0.1	
Exercise	All users can walk (100%) / use public transport (50%) to get to recreation/exercise facilities	80	0.8	
Participation & Control			1.5	
Environmental control	% of occupied space able to control their thermal environment (adjacent to openable windows/thermal controls)	0	0.0	
Lighting control	% of occupied space able to control their light (adjacent to controllable blinds etc/local lighting control)	0	0.0	
Social spaces	Social informal meeting spaces (parks / staff canteens / cafes) provided locally (within 400m) (100%)	0	0.0	
Sharing facilities	5% or more of facilities shared with other users / organisations on a weekly basis (100%)	60	0.6	Yoga on waterfront
User group	Users actively involved in the design process (50%) / Active and representative management user group (50%)(Refer to Credit 2.3 SSI for percentage allocation)	0	0.0	
Education, Health & Safety			2.0	
Education	Two percent or more space/facilities available for education (seminar rooms / reading / libraries) per occupied space (75%). Construction training provided on site (25%)(refer to credit 6.3 of SSI for credit allocation)	60	0.6	The landscape provides educational facilities in the fore court
Safety	All well used routes in and around landscape well lit (25%), all routes in and around landscape is visually supervised (25%), secure perimeter and access control (50%), No crime (100%)(refer to Credit 6.5 of SSI for percentage allocation)	50	0.5	
Awareness	% of users who can access information on health & safety issues (ie HIV/AIDS), training and employment opportunities easily (posters/personnel/intranet site)	0	0.0	
Materials	All materials/components used have no negative effects on indoor air quality (100%)	0	0.0	
Accidents	Process in place for recording all occupational accidents and diseases and addressing these	0	0.0	
Physical activity	Provide opportunities for outdoor physical activity(refer to credit 6.6 of SSI for percentage allocations)	60	0.6	Landscape provides opportunity for bicycle riding, jogging etc.
Historical places	protect and maintain cultural and historical places(refer to credit 6.4 in SSI for percentage allocation)	70.0	0.7	

8.3.2.2 Economic

Criteria	Indicative performance measure	Measured	Points	Point value description
Criteria unchanged by proposal in grey				
changed criteria to meet landscape requirements				
EC 1	Local economy	Explanatory notes		2.4
EC 1.1	Local contractors	% value of the landscape constructed by local (within 50km) small (employees<20) contractors	50	0.5
EC 1.2	Local materials	% of materials (sand, bricks, blocks, roofing material) sourced from within 50km	10	0.1
EC 1.3	Local components	% of components (windows, doors etc) made locally (in the country)	0	0.0
EC 1.4	Local furniture/fittings	% of furniture and fittings made locally (in the country)	80	0.8 Bamboo seats made on site
EC 1.5	Maintenance	% of maintenance and repairs by value that can, and are undertaken, by local contractors (within 50km)	50	0.5
	Equitable site development	Promote equitable site development(refer to credit 6.1 of SSI for percentage allocation)	50	0.5
	Equitable site use	Promote equitable site use (refer to credit 6.2 of SSI for percentage allocation)	50	0.5
EC 2	Efficiency	Explanatory notes		2.2
EC 2.1	Capacity	% capacity of landscape used on a daily basis (actual number of users / number of users at full capacity*100)	60	0.6 Site is over populated in train times
EC 2.2	Occupancy	% of time landscape is occupied and used (actual average number of hours used / all potential hours landscape could be used (24) *100)	60	0.6 Diverse environment allows for different activities to occur
EC 2.3	Space per occupant	Space provision per user not more than 10% above national average for building type (100%)	0	0.0
EC 2.4	Communication	Site/building has access to internet and telephone (100%), telephone only (50%)	0	0.0
EC 2.5	Material & Components	Landscape design coordinated with material / component sizes in order to minimise wastage. Floor (50%), other built elements (50%)	10	0.1
EC 3	Adaptability	Explanatory notes		1.8
EC 3.1	Vertical heights	% of spaces that have a floor to ceiling height of 3000mm or more	0	0.0
EC 3.2	External space	Design facilitates flexible space use (100%) landscape can be used in more than one way	60	0.6 Square is robust to be used as a stage, or space where people can wait for the train.
EC 3.3	Internal partition	Non loadbearing internal partitions that can be easily adapted (loose partitioning (100%), studwall (50%), masonry (25%))	0	0.0
EC 3.4	Modular planning	Building with modular structure, envelope (fenestration) & services allowing easy internal adaptation (100%)	0	0.0
EC 3.5	Furniture	Modular, limited variety furniture - can be easily configured for different uses (100%)	0	0.0
	Deconstruction	Landscape intervention can easily be reversed/ deconstructed	10	0.1
EC 4	Ongoing costs	Explanatory notes		0.6
EC 4.1	Induction	All new users receive induction training on landscape systems (50%), Detailed landscape user manual (50%)	10	0.1 operators receive detailed user manual. Users need not
EC4.2	Consumption & waste	% of users exposed on a monthly basis to building performance figures (water (25%), electricity (25%), waste (25%), accidents (25%))	0	0.0
EC 4.2	Metering	Easily monitored localised metering system for water (50%) and energy (50%)	0	0.0
EC4.3	Maintenance & Cleaning	% of landscape that can be cleaned and maintained easily and safely using simple equipment and local non-hazardous materials	0	0.0
	performance of design	Monitor performance of sustainable design(refer to credit 9.1 of SSI for percentage allocation)	0	0.0
SO 4.5	Procurement	% of value of all materials/equipment used in the landscape on a daily basis supplied by local (within the country) manufacturers	50	0.5 Bamboo manufacture
EC 5	Capital Costs	Explanatory notes		1.3
EC 5.1	Local need	Five percent capital cost allocated to address urgent local issues (employment, training etc) during construction process (100%)	0	0.0
EC5.2	Procurement	Tender / construction packaged to ensure involvement of small local contractors/manufacturers (100%)	0	0.0
EC 5.3	Building costs	Capital cost not more than fifteen % above national average landscape costs for the landscape type (100%)	0	0.0
EC5.4	Technology	3% or more of capital costs allocated to new sustainable/indigenous technology (100%)	50	0.5
EC 5.5	Existing Buildings	Existing urban environments reused (100%)	80	0.8

Criteria	Indicative performance measure	Measured	Points	Point value description
criteria changed to meet landscape requirements indicated in red				Not NB for landscapes
EN 1	Water	Explanatory notes		2.8
EN 1.1	Rainwater	% of water consumed sourced from rainwater harvested on site	80	0.2 Rainwater used for irrigation, but not ablutions
EN 1.2	Water use	% of equipment (taps, washing machines, urinals showerheads) that are water efficient	10	0.1
EN 1.3	Runoff	% of carparking, paths, roads and roofs that have absorbant/semi absorbant/permeable surfaces (grassed/thatched/looselaid paving/ absorbant materials)	40	0.4 Water runs from hard surfaces into bamboo
EN 1.4	Grey water	% of water from washing/relatively clean processes recycled and reused	50	0.5 Water from hand basins is recycled
EN 1.5	Planting	% of planting (other than food gardens) on site with low / appropriate water requirements	0	0.0 Bamboo has high water requirements
EN 1.6	Reduce potable water	Reduce potable water for landscape irrigation by 75 % or more from established baseline(Refer to credit 3.2 SSI for	100	1.0 Only rainwater is used to irrigate the the landscape
EN 1.7	Protect on-Site Water	Protect and enhance on-site water resources and receiving water quality (refer to credit 3.6 SSI for percentage allocation)	100	1.0 Water pumped from Daspoort it proposed to cease. Water
EN 1.8	Storm water Amenitly	Design rainwater/storm water features in an aesthetically pleasing way(Refer to credit 3.7 SSI for percentage allocation)	50	0.5 Water flows from surfaces into bamboo beds and pumped
EN 1.9	Water Features	Only applicable to designs with water features(refer to EN 1.9 on criteria notes of SBAT excel spreadsheet)	70	0.7 The proposed zero depth water feature uses less than
EN 1.10	Natural Water masses	Only applicable to sites with river, wetlands and shoreline buffers(refer to EN 1.10 on criteria notes tab of SBAT excel spreadsheet)	60	0.6 The design of the waterfront is not within the recommended 15m away from the established riparian zone. The deck sits in the water. Appropriate aquatic species is specified. The potential threat to the restored ecosystem is still present.Man made dams are not considered as aquatic eco systems. but is considered in this case because of the age of the dam .(1930)
EN 1.11	Rehabilitate lost natural water	Only applicable to sites which have lost streams, wetlands and shorelines (Refer to EN 1.11 on criteria notes tab Of SBAT Excel spreadsheet)	0	0.0
EN 2	Energy	Explanatory notes		1.2
EN 2.2	Ventilation	% of building ventilation requirements met through natural / passive ventilation	0	0.0
EN 2.3	Heating & Cooling	% of occupied space which relies solely on passive environmental control (no or minimal energy consumption)	0	0.0
EN 2.4	Appliances & fittings	% of appliances / lighting fixtures that are classed as highly energy efficient (ie energy star rating)	20	0.2
EN 2.5	Renewable energy	% of landscape energy requirements met from renewable sources(refer to credit 8.5 of SSI for percentage allocation)	50	0.5 Solar lighting is proposed
	vegetation to minimize outdoor energy consumption	use vegetation to minimize buildings heating and cooling requirements(refer to credit 4.10&4.11 of SSI for percentage allocation)	0	0.0
	Reduce outdoor energy consumption	Reduce outdoor energy consumption for all landscape operations(refer to credit 8.4 of SSI for percentage allocation)	50	0.5 Solar pump proposed to pump water from reservoir to water channel
	car emission	Reduce emissions and promote the use of fuel efficient vehicles(refer to credit 8.8 of SSI for percentage allocation)	0	0.0
EN 3	Waste	Explanatory notes		0.8
EN 3.1	Toxic waste	% of toxic waste (batteries, ink cartridges, flourescent lamps) recycled	0	0.0
EN 3.2	Organic waste	% of organic waste recycled	50	0.5 Bamboo offcuts and leaves used in horse stables and as
EN 3.3	Inorganic waste	% of inorganic waste recycled.	0	0.0
EN 3.4	Sewerage	% of sewerage recycled on site	0	0.0
EN 3.5	Construction waste	% of damaged building materials / waste developed in construction recycled on site	10	0.1
	light pollution	Reduce light pollution (refer to credit 6.9 of SSI for allocation oof percentage)	40	0.4 Light pollution is increased to ensure safety in public spaces
	greenhouse gas	Minimize greenhouse gas emissions during construction(refer to credit 7.6 of SSI for percentage allocations)	0	0.0 Project not constructed
	maintenance waste	Recycle organic matter generated during Maintenance (refer to credit 8.3 in SSI for percentage allocation)	20	0.2 Organic waste recycled to compost pile
	Tabacco	minimize exposure to environmental tabacco smoke(refer to credit 8.6 of SSI	30	0.3 Smoking in the square is prohibited
	greenhouse gasses:	minimize generation of greenhouse gasses and exposure to localized air pollutants during maintenance activities(refer to	0	0.0

EN 4 Site		Explanatory notes	3.3
EN 4.1	Brownfield site	% of proposed site already disturbed / brownfield (previously developed)(Refer to credit 1.5 SSI for percentage allocation)	80
			0.8 All indigenous species on the brownfield site is protected. The site has the potential to regenerate habitats that previously existed on the site.
EN 4.2	Neighbouring buildings	No neighbouring buildings negatively affected (access to sunlight, daylight, ventilation) (100%)	0
			0.0 Buildings are affected by the bamboo forest
EN 4.3	Vegetation	% of area of area covered in vegetation (include green roofs, internal planting) relative to whole site	40
			0.4
EN 4.4	Food gardens	Food gardens on site (100%)	60
			0.6 Food garden is incorporated in the noterhern portion of the site.
EN 4.5	Landscape inputs	% of landscape that does not require mechanical equipment (ie lawn cutting) and or artificial inputs such as weed killers and pesticides	100
			1.0
EN 2.1	Location	% of users who walk / cycle / use public transport to commute to the precinct(refer to credit 1.7 SSI for percentage	80
			0.8 people arrive via, bus train, taxi or by foot
	Soil disturbance	Minimize soil disturbance in design and construction (refer to credit 4.4 of SSI for percentage allocation	100
			1.0
	Special status	Preserve all vegetation designated as special status (Refer to credit 4.5 of SSI for percentage allocation)	90
			0.9 PG Smit dissertation
	Biomass	Preserve and restore appropriate biomass on site(refer to credit 4.6 of SSI for percentage allocation)	50
			0.5
	restore soils	restore soils disturbed by previous development(refer to credit 7.3 of SSI for percentage allocation)	60
			0.6 PG Smit dissertation, addresses the soil restoration. Bamboo
EN 5 Materials & Component		Explanatory notes	2.5
EN 5.1	Embodied energy	Materials with high embodied energy (aluminium,plastics) make up less than 1% of weight of implemented landscpae materials (100%)	40
			0.4 Steel is used for its tensile strength, ability to span and robustness in the urban context.
EN 5.2	Material sources	% of materials and components by volume from grown sources (animal/plant)(refer to Credit 5.10of SSI for percentage allocation)	50
			0.5 Bamboo and repurposed wood is used in conjunction with steel
EN 5.3	Ozone depletion	No materials and components used requiring ozone depleting processes (100%)(refer to credit 5.8)	100
			1.0
EN 5.4	Recycled / reuse	% of materials and components (by weight) reused / from recycled sources (refer to credit 5.5 of SSI forpercentage	10
			0.1 Repurposed wood is used
EN 5.5	Construction process	Volume / area of site disturbed during construction less than 2X area of new landscape (100%)	20
			0.2
EN 5.6	Native plants	The use of native plants (refer to credit 4.7 SSI for percentage allocation)	70
			0.7
EN 5.7	Ecoregion preservation	Preserve plant communities native to ecoregion (refer to credit 4.8 of SSI for percentage allocation	100
			1.0 All plantspecies identified and protected
EN 5.8	Ecoregion restoration	Restore plant communities native to region (refer to credit 4.9 of SSI for percentage allocation)	80
			0.8 Biodiversity park is proposed
EN 5.9	Reduce heat island effect	Use vegetation and reflective materials to reduce heat island and minimize effects on microclimate and on human and wildlife habitat	50
			0.5
EN 5.10	Deconstruction and disa:	deisgn for deconstruction and disassembly, to avoid sending usefull materials to landfills(refer to credit 5.3 of SSI for percentage allocation)	20
			0.2 Materials are chosen for long life splan. Wood materials can decompose over time
EN 5.11	Re use salvaged materia	Reuse of salvaged materials or plants(refer to credit 5.4 of SSI for percentage allocation)	20
			0.2
EN 5.12	Use of certified wood	Purchase certified lumber to encourage exemplary forest management(refer to credit 5.6 in SSI forpercentage allocation)	90
			0.9 Bamboo products are used
EN 5.13	Regional materials	Use regional materials(refer to Credit 5.7 in SSI for percentage allocation)	66
			0.7
EN 5.14	sustainable plant production	Support sustainable practices in plant production(refer to credit 5.9 of SSI for percentage allocation)	10
			0.1
EN 5.15	Divert construction and demolition materials	divert construction and demolition materials from disposal (refer to credit 7.4 of SSI for percentage allocation)	20
			0.2
EN 5.16	Construction recycle	reuse recycle vegetation,rocks, and soil generated during construction (refer to credit 7.5 of SSI for percentage allocation)	50
			0.5

9 . B I B L I O G R A P H Y

African planning Association, 2014. The state of planning in Africa. UN Habitat for a better future, p. 14.

Amir Djalali, P. V., 2008. The complex history of sustainability. Amsterdam: Archis OMA.

Armstrong, E. H., 2006. Post-Urban/Suburban Landscapes: Design and Planning the Centre, Edge. Sydney, Sydney:Centre for cultural research.

Beatly, T., 2010. Biophilic cities, integrating nature into urban design and planning. Washington DC: Island Press.

Brightfields Natural trading company, 2009. Brightfields Blog. [Online] Available at: <http://www.brightfields.co.za/blog/2013/11/18/notes-from-fnb-enablist-seda-business-launchpad-competition-2009>[Accessed 12 February 2014].

Butler, B.R., 2008. Topics in architectural theory. Contemporary Theory ARCH 6271, Fall.

Campbell, K., 2011. Massive Small: The operating programme for smart Urbanism. 1 ed. England: Urban Exchange.

Campbell, K., 2014. Massive Small. Tshwane, s.n.

Capra, F., 1997. The Web of life. London: Harper Collins publishers.

Central intelligence agency, 2013. unemployment rate. [Online] Available at: https://www.cia.gov/search?q=unemployment&site=CIA&output=xml_no_dtd&client=CIA&myAction=%2Fsearch&proxystylesheet=CIA&submitMethod=get [Accessed March 2014].

Ching, Francis D K. 2007. Architecture: Form space and order. 3rd. New York : John Wiley & Sons, Inc., 2007. pp. 264-265.

City of Tshwane, 2012 June. City of Tshwane metropolitan spatial development framework.

City of Tshwane, 2013. Tshwane Vision 2055, Remaking South Africa's Capital City. p.18

Clark, T., 2010. Preserve. Integrate. Intervene. Progression at the Pretoria West Power plant, Pretoria: University of Pretoria.

Cole, R. J., 2012. Regenerative design and development: current theory and practice. Building research & information, pp. 1-6.

Cumming, G. S., and J. Collier. 2005. Change and identity in complex systems. Ecology and Society 10(1):29. [online] URL: <http://www.ecologyandsociety.org/vol10/iss1/art29/>. Davey, C., 2010. Proximity:Vertical Agriculture The old pretoria West power station, Pretoria: University of Pretoria.

- Davey, C. (2010). Proximity:Vertical Agriculture The old pretoria West power station. University of Pretoria, Department of Architecture. Pretoria: University of Pretoria.
- Dunkelberg, K., 2002. Bamboo as a building material. Karl kramer verlag Stuttgart, pp. 1-16.
- duPlessis, C., 2012. Beyond sustainability to a regenerative world. Pretoria: University of Pretoria.
- Frith, A., 2013. Dot-maps of racial distribution in South African cities. [Online] Available at: <http://adrianfrith.com/2013/09/08/dot-maps-of-racial-distribution-in-south-african-cities>[Accessed 18 February 2014].
- Gehl, J., 2006. Life between buildings: Using Public Space. 6th ed. Copenhagen: The Danish Architectural Press.
- German, K., 2006. The art of designing a meaningful landscape through storytelling, Alexandria: Virginia Polytechnic institute.
- Gruyer, N., Dorais, M., Zagury, G. J. & Alsanius, B. W., 2013. Removal of plant pathogens from recycled greenhouse water husing constructed wetlands. Agricultural water amangement , Issue (117), pp. 153-158.
- Hanson, K., 2009. Bamboo Agroforestry. [Online] Available at: <http://www.wildthymefarm.com/agrobamboo.html>[Accessed 30 August 2014].
- Heijden, J.v.d., 2013. Towards truly resilient cities: stop being soft on old buildings. [Online] (1) Available at: <http://theconversation.com/towards-truly-resilient-cities-stop-being-soft-on-old-buildings-21071> [Accessed 2 October 2014]. Helie, M., 2012. The Meaning of Emergent Urbanism, after A New Kind of Science. [Online] Available at: <http://emergenturbanism.com/>[Accessed 21 April 2014].
- Helie, M. (2012, May 21). The Meaning of Emergent Urbanism, after A New Kind of Science. Retrieved April 21, 2014, from Emergent urbanism:Rediscovering urban complexity: <http://emergenturbanism.com/>
- Hester, M. F. a. R., 1995. The meaning of gardens. s.l.:MIT press.
- International federation of lanscape arcihtects, 2014. About landscape architecture. [Online] Available at: <http://iflaonline.org/about/>[Accessed 23 May 2014].
- Inan, A., 2011. From Dichotomy to Dialectic: Practicing theory in urban design. Journal of urban design, May, 16(2), pp. 257-277.
- Jackson, J., 1984. Discovering the vernacular landscape, Newhaven and London: Yale University Press.
- Jax, S. B. a. K., 2007. Focussing the meaning(s) of resilience: Resillience as a descriptive concept and a boundary object. Ecology and soceity , 112(1).

Joubert, D., 2010. [ex]-change: and architecture for experience. A train station, Pretoria: University of Pretoria.

Joubert, P., 2010. Whaen climate inspires change. Pretoria: Pieter Joubert.

Kellert, S. R., Heerwagen, J. H. & Mador, M. L., 2008. Biophilic design: the theory, science, and practice of bringing buildings alive. 1 ed. Hoboken, New Jersey: John Wiley and sons.

Kokalanova, A., 2013. Dealing with urban Borders. Berlin , Hafen City University.

Koolhaas, Rem (2005) 'The Generic City', in A. Abbas & J. N. Erni (eds), Internationalizing Cultural Studies: An Anthology. Malden, MA: Blackwell. Pp 637-649.

Landezine/ landscape architecture works, 2012. Qinhuandao botanic garden by Turenscape. [Online] Available at: <http://www.landezine.com/index.php/2012/11/qinhuangdao-botanic-garden-by-turenscape/>[Accessed 22 May 2014].

Landezine/ Landscape Architecture works, 2014. Twisted Valley by Grupo Aranea. [Online] Available at: <http://www.landezine.com/index.php/2014/01/twisted-valley-by-grupo-aranea/>[Accessed 14 May 2014].

Landezine/Landscape architecture works, 2014. The Forest @ Pyne by Sansiri by TROP. [Online] [Accessed 13 May 2014].

Masut, F., 2014. Site supervisor [Interview] (3 March 2014).

McConnell, R. L. & Abel, D. C., 2002. Environmental Issues: Measuring, Analyzing, and Evaluating. s.l.:Prentice Hall PTR.

Mehaffy, M. & Salingaros, N.A., 2013. Metropolis. [Online] (1) Available at: <http://www.metropolismag.com/Point-of-View/March-2013/Toward-Resilient-Architectures-1-Biology-Lessons/> [Accessed 2 October 2014].

Mier et al, 2014. The investigation of currently inhabited villages of medieval origin: Agrarian archaeology in Asturias (Spain). Quaternary International, pp. 1-15.

MIT Press, 2014. The New Science of Cities. [Online] (1) Available at: <http://mitpress.mit.edu/books/new-science-cities> [Accessed 2 October 2014]. Newman, P., 2014. Biophilic urbanism: a case study on Singapore. Australian Planner, 51(1), pp. 47-65.

Newman, P. (2014, February 19). Biophilic urbanism: a case study on Singapore. Australian Planner, 51(1), 47-65.

Newman, T. & Beatly, P., 2013. Biophilic Cities Are Sustainable, Resilient Cities. sustainability, 5 August.pp. 3328-3344.

Oxford University press, 2014. Oxford dictionary 9th edition. England: Oxford unversity press.

- Pallasmaa, J., 2005. *The eyes of the skin*. West Eussex, England: John Wiley.
- Pauw, I., 2010. [re]-find Pretoria West station: reproducing the furniture industry through adaptive reuse, Pretoria: University of Pretoria.
- Relph, E., 1976. *Place and placelessness*. London: Poin.
- Sampson, J., 2014. University of Pretoria Curator [Interview] (26 March 2014).
- Science Fried Art, 2014. Soceity 6. [Online] (1) Available at: http://society6.com/biologyfriednoodleprints/old-light-microscope_print#1=45 [Accessed 2014 October 2014].
- Smit, P., 2010. *Going west: Using Landscape to regenerate urban form*, Pretoria: University of Pretoria.
- Taylor, K., 2007. *Landscape and Memory: Cultural landscapes, intangible values and some thoughts on Asia*, Melbourne: The Australian national University: Research school of humanities.
- Treib, M., 2002. Must landscapes mean. In: S. Swaffield, ed. *Theory in landscape architecture: A Reader*. 2nd ed. Pennsylvania: University of Pennsylvania Press , pp. 89-101.
- UN-Habitat, 2014. *The state of African cities*. 1 ed. Nairobi: United Nations Human Settlements programme.
- University, Loughborough. 2012. *Toolkit: Integrating context. adaptable futures*. [Online] 2012. [Cited: May 5, 2014.] <http://adaptablefutures.com/toolkit/d02-integrating-context/>.
- van Schaik, Leon & Golling, John (2006) *Design City Melbourne*. Melbourne: JohnWiley & Sons.
- van Biljon, J., 2010. [Re]-dress. A fashion event facility in Pretoria West, Pretoria: University of Pretoria.
- Viljoen, C., 2007. *Crotalaria capensis*. [Online] Available at: <http://www.plantzafrica.com/plantcd/crotalcapen.htm>[Accessed 30 August 2014].
- Wu, X., 2011. *Productive Landscape, Urbana*: University of Illinois, department of Architecture.