



University of Pretoria
Department of Economics Working Paper Series

**Growth-Effects of Inflation Targeting: The Role of Financial
Sector Development**

Rangan Gupta

University of Pretoria

Working Paper: 2006-10

March 2006

Department of Economics

University of Pretoria

0002, Pretoria

South Africa

Tel: +27 12 420 2413

Fax: +27 12 362 5207

<http://www.up.ac.za/up/web/en/academic/economics/index.html>

Growth-Effects of Inflation Targeting: The Role of Financial Sector

Development

Rangan Gupta

Contact Details: Dr. Rangan Gupta, Senior Lecturer, University of Pretoria, Department of Economics, Pretoria, 0002, South Africa, Email: Rangan.Gupta@up.ac.za. Phone: +27 12 420 3460, Fax: +27 12 362 5207.

ABSTRACT The paper develops a dynamic general equilibrium monetary endogenous growth model of a closed economy inhabited by consumers, firms, a Cournotian monopolistically competitive banking system, besides, an inflation-targeting monetary authority, and, in turn, analyzes the effect of a tight monetary (disinflationary) policy on growth. We show that the effect of lower inflation target on growth is ambiguous, with the ultimate effect depending on the initial level of growth, the individual bank size, the degree of risk aversion, the elasticity of output with respect to capital, the discount factor and the size of the cash-reserve ratio.

KEY WORDS: Inflation Targeting, economic growth, financial sector development

JEL CODES: E31, E44, E52

1. Introduction

The paper develops a dynamic general equilibrium monetary endogenous growth model of a closed economy characterized, by a monetary authority targeting inflation, and, in turn, analyzes the effect of a tight (disinflationary) monetary policy on growth. Besides, the inflation targeting infinitely-lived government, the model economy is inhabited by consumers, firms and a Cournotian monopolistically competitive banking system. Assuming a monopolistic banking system provides us the flexibility of analyzing the role of financial sector development in determining the growth-effects of lower inflation targets, and, simultaneously, depict a developed and an emerging market economy within the same theoretical framework. Such a specification of the banking system is an essential component of our model.

As Berthélemy and Varoudakis (1997) points out that countries in which financial sector development has been repressed, as has been the case in most developing nations, usually have highly oligopolistic banking system, however, the banking system is substantially more competitive in the developed countries.

Though there does not exist an universally accepted definition for inflation targeting, in general, the policy involves the public announcement of a quantitative inflation target, the commitment of the monetary authority towards price stability, a high degree of transparency in policy making, and the imposition of the accountability of the central bank. The framework of inflation targeting, has received significant attention from economists and policy makers alike, with both developed and developing countries adding to the list.¹

Recent studies inquiring as to whether tight monetary policy, in such a framework, is growth enhancing, find varied results. While Mishkin (2001), Neumann and von Hagen (2002), Ball and Sheridan (2003) and Apergis *et al.*, (2005), finds positive growth-effect of disinflation, Lavoie (2002), Leon-Ledesma and Thirlwall (2002), Dutt and Ros (2003), Fraga, Goldfajn and Minella (2003), and Libanio (2005) indicates plausible unfavorable influences of the lower inflation targets on growth. In such a situation, with developing and emerging economies also shifting to such a framework, a pertinent question is what are the essential prerequisites for inflation targeting to have positive growth effects.

In this regard, our analysis, provides a theoretical explanation as to why a disinflationary policy can have ambiguous growth effects and, in the process, identifies the importance of financial sector development as an essential prerequisite to reap the positive growth effects of inflation targeting. Recently, Mishkin (2004) indicates at four institutional aspects that

might be lacking in the emerging market economies for inflation targeting policies to become fruitful. He lists the following (i) weak fiscal and financial institutions; (ii) low credibility of monetary institutions; (iii) currency substitution and liability dollarization; and (iv) greater vulnerability to external shocks, in particular, “sudden stops” of capital inflow. In this paper, we indicate that for lower inflation targets, pursued by a monetary authority, to have positive growth effects, a relatively well-developed financial sector is essential. Our analysis can, thus, be viewed as to providing a theoretical formalization to one aspect of the essentials numbered (i), stated above, in Mishkin (2004).

Moreover, the existing literature on monetary policy in an endogenous growth model, as in Espinosa and Yip (1999), Kudoh (2004a, 2004b), admits the possibility of multiple growth equilibria, and we observe the same in our analysis. Under such circumstances, it is important to devise a mechanism that would allow the agents to choose a specific equilibria. The fact that the high-growth equilibrium is Pareto superior and stable does not ensure the choice of the same by the agents.² In the spirit of Evans *et al.*, (1998), Kudoh (2004b) designs an adaptive learning process as a device for equilibrium selection. The author shows that under nominal interest rate pegging (equivalent to inflation targeting in an AK-type endogenous growth model), the equilibria are stable, and, hence, one has expectational indeterminacy. Kudoh (2004b), further indicates that even though fiscal policy can eliminate such indeterminacy, the high-welfare equilibrium is unachievable. We are, however, able to show that once a threshold level of financial development has been achieved, the high-growth and high-welfare (stable) equilibrium will be the only available equilibrium for the economy to choose. The paper is organized in the following order: Besides

the introduction and conclusion, Section II outlines the economic environment while Section III defines the equilibrium and lays out the balanced growth equations. Finally, Section IV analyzes the effects of a deflationary policy on growth and discusses the results.

2. Economic Environment

We consider an infinitely-lived representative agent model with no uncertainty and complete markets. The economy is populated by four types of decision makers: households, banks, firms, and the government. In this model, there is only one type of consumption good, called the cash goods. The cash good and the investment good, are produced by the same technology. Explicitly modeling the financial intermediaries, operating in a Cournotian monopolistically competitive environment and obligated to hold mandatory reserve requirements, we assume that all capital is intermediated as loans through the banking system.

The resource constraint in the model economy is given by

$$c_t + i_{kt} \leq Ak_t^\alpha (n_t \bar{k}_t)^{1-\alpha} \quad (1)$$

where c_t is the consumption of cash goods; i_{kt} is the investment expenditure in physical capital; A is a positive scalar; $0 < \alpha < 1$, is the elasticity of output with respect to capital; n_t is the hours of labor supplied inelastically to production (the remaining $(1 - n_t)$, is supplied in the banking sector), given the one unit of labor time available, and; \bar{k}_t denotes the aggregate capital stock. Physical capital evolve according to the following processes $k_{t+1} \leq (1 - \delta_k)k_t + i_{kt}$ where k_t is the capital stock in period t and δ_k is the depreciation rate.

Note the production technology used here is motivated from the works of Romer (1986), Bencivenga and Smith (1991) and Espinosa and Yip (1996). The aggregate capital stock enters the production function to account for a positive externality indicating an increase in labor productivity as the society accumulates capital stock. It must be noted that in equilibrium, $k_t = \bar{k}_t$. Since both the consumption and the investment goods are available in a period of time are perfect substitutes on the production side, they all sell for the same nominal price p_t .

Events in the economy can be captured by the following sequence: At the beginning of each period, a securities market opens. In this market, households receive labor income and proceeds from their savings, made in the previous period, and any lump-sum transfers from the government. Note the only available form of savings for the households is through deposits. Finally, households choose the cash they need to hold for the purchase of cash goods in the next period.

On the production side, given that all capital is intermediated through the banking system, firms must borrow to finance the purchases of capital. The financial intermediaries are assumed to offer one-period deposit contracts to households, and are also required to hold mandatory cash reserves. The freely available deposits remaining after the reserve requirements have been met are then used to make the loans, required to finance the capital needs of the firm. We assume that to be operated the banks require resources in the form of labor. Note the role of money, in this model, is introduced through the cash-in-advance and reserve requirements.

The government makes lump-sum transfer payments to the households and finances the

same, in any period, only through seigniorage. For the sake of simplicity we ignore taxes from the government budget constraint, however, for technical reasons outlined below, we assume that there are no government bonds.

2.1 Consumers

Before formally stating the consumer problem, it must be pointed out that the household inelastically supply the available one unit of labor for production and bank operation, the distribution of which is demand determined, based on the firms and the banks optimization problems. We assume that there is a large number of identical households that solve the following problem:

$$V = \max_{c_t, d_t, m_{1t}} \sum_{t=0}^{\infty} \beta^t u(c_t) \quad (2)$$

s.t. :

$$p_t c_t \leq m_{1t-1} \quad (3)$$

$$d_t + m_{1t} \leq p_t w_t + [1 + R_{dt}]d_{t-1} + (m_{1t-1} - p_t c_t) + T_t \quad (4)$$

with d_{t-1} , m_{1t-1} , R_{dt} , w_t and p_t as given. Note, β is the discount factor; u is the instantaneous iso-elastic ($\frac{c_t^{1-\sigma}}{1-\sigma}$) utility function of the consumer, with c_t denoting consumption; m_{1t-1} denotes the cash reserves required in period $t - 1$ to meet the consumption needs of period t ; d_t is the deposits in the banking system; R_{dt} is the nominal interest rate paid on deposits at the end of period t ; T_t is the size of the transfer to the household delivered for use in period t ; w_t is the real wage rate; So consumers maximize their lifetime utility (equation

(2)) subject to equations (3) and (4) , to determine a contingency plan for $\{c_t, d_t, m_{1t}\}_{t=0}^{\infty}$.

The consumer's optimization problem can be written in the following recursive formulation.

$$J(d_{t-1}, m_{1t-1}) = \max_{c_t, m_{1t}, d_t} \left\{ \begin{array}{l} u(c_t) + \beta J(d_t, m_{1t}) \\ + \lambda_{1t} \left(\begin{array}{l} m_{1t-1} - p_t c_t + p_t w_t \\ + [1 + R_{dt}] d_{t-1} + T_t - d_t - m_{1t} \end{array} \right) \\ + \lambda_{2t} (m_{1t-1} - p_t c_t) \end{array} \right\} \quad (5)$$

The upshot of the dynamic programming problem are the following first order conditions:

$$c_t : u_c(c_t) - p_t(\lambda_{1t} + \lambda_{2t}) = 0 \quad (6)$$

$$d_t : \beta J_1(d_t, m_{1t}) - \lambda_{1t} = 0 \quad (7)$$

$$m_{1t} : \beta J_2(d_t, m_{1t}) - \lambda_{1t} = 0 \quad (8)$$

$$\lambda_{1t} : \left\{ \begin{array}{l} m_{1t-1} - p_t c_t + p_t w_t \\ + [1 + R_{dt}] d_{t-1} + T_t - d_t - m_{1t} \end{array} \right\} = 0 \quad (9)$$

$$\lambda_{2t} : (m_{1t-1} - p_t c_t) = 0 \quad (10)$$

Along with the following envelope conditions

$$J_1(d_{t-1}, m_{1t-1}) = \lambda_{1t} [1 + R_{dt}] \quad (11)$$

$$J_2(d_{t-1}, m_{1t-1}) = \lambda_{1t} + \lambda_{2t} \quad (12)$$

$$(13)$$

In addition, a transversality condition is necessary to ensure the existence of the household's present-value budget constraint. The household's terminal constraint is interpreted as a non-ponzi condition in which the household cannot borrow against future deposits at a rate greater than can be repaid. Formally, the transversality condition is represented as

$$\lim_{T \rightarrow \infty} \left[\frac{d_T}{\prod_{s=0}^{T-1} [1 + R_{ds}]} \right] \quad (14)$$

Using the first order conditions, along with the envelope conditions, the consumer's problem yields the following efficiency condition.

$$u_c(c_t) = \beta \frac{u_c(c_{t+1})}{\frac{p_{t+1}}{p_t}} [1 + R_{dt}] \quad (15)$$

Equation (15) is the efficiency condition for consumption. On the left hand side is the marginal cost of foregoing one unit of consumption, while the right hand side of equation (15) is the benefit of the received in the future from foregone consumption. Note once the consumption path is determined the time paths for the money demand and the deposit can be derived from the constraints, specifically, equations (2) and (3), respectively. Using the utility function equation (15) boils down to

$$\left(\frac{c_{t+1}}{c_t} \right)^\sigma = \beta \frac{[1 + R_{dt}]}{\frac{p_{t+1}}{p_t}} \quad (16)$$

2.2 Financial intermediaries

The financial sector is modeled along the lines of Berthélemy and Varoudakis (1997).

There exists N banks operating in a Cournotian monopolistically competitive environment. Banks are confronted with a savings (deposit) supply function and they maximize profit at a given point of time, assuming that the volume of savings collected by the $(N - 1)$ other banks remains unchanged. Note that, though, the banks have no way of influencing the interest rate on the loans, since it is tied to the marginal product of the capital³, each bank will be able to influence the rate of return on the deposits, given the supply function of savings. We will assume that the behavior of the banks remain unchanged in future periods.

The financial intermediation technology, can be described as follows: With γ_t defined as the fraction of the deposits held as cash reserves by any bank i , the maximum amount of deposits that can be intermediated by each bank i is $(1 - \gamma_t)d_{it}$. However, we will assume that not all of the available deposits can be loaned out. Each bank can only intermediate $\psi_{it}(1 - \gamma_t)$ of the savings it collects, given the financial intermediation margin. ψ_{it} depends on the quantity of real resources used by the bank. Denoting the level of employment in the representative bank by ϑ_{it} , we assume that $\psi_{it} = \psi_i(\vartheta_{it})$, with $\psi'_i > 0$. Given that the banks are symmetrical, $\vartheta_{it} = \frac{1-n_t}{N}$, in equilibrium. The feasibility condition requires that $l_{it} + m_{2it} \leq d_{it}$, where l_{it} is the nominal quantity of bank loans, and; $m_{2it} \geq \gamma_t d_{it}$, denotes the cash reserve requirement of bank i . The conditions should hold as equality as money is return dominated, and is not optimal for the banks to hold excess reserves.

Given that $l_{it} = \psi_{it}(1 - \gamma_t)d_{it}$, there exists increasing returns to scale, at the level of individual banks, with respect to deposits d_i and employment ϑ_i . As Berthélemy and Varoudakis (1997) indicates, such a technology could be justified on the grounds of learning-by-doing effects in financial intermediation activities, affecting the labor productivity in the banking

sector. In accordance with the framework of imperfect competition, these effects are assumed to be internal to the banks. Such learning-by-doing effects could presumably be linked to the size of financial market (volume of deposits) divided by N , i.e., to the scale of operation of each bank. The externality, exerted from the real to the financial sector, establishes an interaction between the two sectors of the economy.

The bank's profit maximization problem, formally, can be stated as follows:

$$\max_{d_i, \vartheta_i} \Pi_{Bi} = (1 + R_{lt})l_{it} + m_{2it} - \vartheta_{it}p_t w_t - (1 + R_{dt})d_{it} \quad (17)$$

$$s.t. \quad : \quad l_{it} = \psi_i(1 - \gamma_t)d_{it} \quad (18)$$

$$m_{2it} = \gamma_t d_{it} \quad (19)$$

where Π_{Bi} is the profit function of bank i and R_{lt} is the nominal rate of interest on loans.

Profit maximization, realizing, $\frac{dd_t}{(1+R_{dt})} \times \frac{(1+R_{dt})}{d_t} = \frac{1}{\sigma}$, $d_{it} = \frac{d_t}{N}$, $l_{it} = \frac{l_t}{N}$, and $\psi_{it} = \psi\left(\frac{1-n_t}{N}\right)$ yields the following set of first-order conditions:

$$d_{it} : (1 - \gamma_t)\psi(1 + R_{lt}) + \gamma_t = \left(1 + \frac{\sigma}{N}\right)(1 + R_{dt}) \quad (20)$$

$$\vartheta_i : (1 - \gamma_t)(1 + R_{lt})\psi' \frac{d_t}{p_t N} = w_t \quad (21)$$

Note, from equation (20), the difference between the nominal gross rate of return on loans $(1 + R_{lt})$ and the nominal gross rate of deposits $(1 + R_{dt})$ is, as expected, related negatively to the degree of competition in the financial sector, expressed by the size of N , and positively to the reserve requirements and the reciprocal of the interest elasticity of the deposits.

Equation (21) implies the equilization of marginal product of labor, in the banking sector, to real wage. This result indicates the external effect of the real sector on the financial sector through the determination of the flow of loans. The larger the size of the financial market, i.e., higher the size of household savings and, hence loans, given ψ , the higher is the labor productivity.

In addition to equation (20) and (21), the free entry condition implying $\Pi_{Bi} = 0$, for all i , determines the number of banks in the long-run equilibrium. Setting $\Pi_{Bi}=0$, and incorporating the feasibility condition, we have the following condition:

$$(1 - \gamma_t)(1 + R_{lt})\psi_{it}d_{it} + \gamma_t d_{it} - \vartheta_i p_t w_t - (1 + R_{dt})d_{it} = 0 \quad (22)$$

Using equation (21) and $\vartheta_i = \frac{1-n}{N}$, we can re-write equation (22) as follows:

$$(1 + R_{lt})(1 - \gamma_t)\psi_t[1 - \epsilon_t] + \gamma_t = (1 + R_{dt}) \quad (23)$$

where $\epsilon (= \frac{1-n}{N} \frac{\psi'}{\psi})$ is the elasticity of the intermediation of deposits with respect to employment at the bank level. Finally, from equations (20) and (23), we have

$$\frac{\sigma}{N} = \frac{(1 + R_{lt})(1 - \gamma_t)\psi_t\epsilon_t}{(1 + R_{lt})(1 - \gamma_t)\psi_t(1 - \epsilon_t) + \gamma_t} \quad (24)$$

Equation (24) determines N in relation to the size of the financial sector $(1 - n)$. It must be pointed out that a positive bi-directional causality is often observed, in cross-sectional data, between the level of financial sector development and intensity of competition in the

banking sector .⁴ As a result, to ensure that (24) holds, it is assumed that ϵ is decreasing with respect to $\frac{1-n}{N}$. Note as N increases the left-hand side falls. Moreover, ψ falls as well. But given that $1 - n$ increases with N , ψ starts to increase and marginal product of capital, and, hence, $(1 + R_{lt})$ starts to fall⁵. Therefore, as a sufficient condition we must assume that ϵ is a decreasing function of $\frac{1-n}{N}$ to maintain the equality in equation (24), given that $\frac{\sigma}{N}$ has gone down, which can only happen with $(1 - n)$ increasing more than N . Realistically, such an assumption is not farfetched since one would expect the percentage change in the coefficient indicating the intermediation of savings expressed as a percentage of the size of the individual bank to show diminishing returns with respect to the latter.

2.3 Firms

The firms purchases capital using financing from the bank, besides, using n_t fraction of the labor time available, to produce the output. The dynamic problem of the firm can be formally represented as follows:

$$\max_{n_t, k_t} \Pi_{Ft} = \sum_{t=0}^{\infty} \rho_t \left[p_t A k_t^\alpha n_t \bar{k}_t^{1-\alpha} - p_t w_t n_t - (1 + R_{lt-1}) l_{t-1} + l_t - p_t i_{kt} \right] \quad (25)$$

s.t. :

$$p_{t-1} k_t \leq l_{t-1} \quad (26)$$

$$k_{t+1} \leq (1 - \delta_k) + i_{kt} \quad (27)$$

where ρ_t is the subjective discount factor of the firms. It must be noted that, from the point of view of the firm, the constraint defined by equation (25) implies that the firm may as

well be considered to be renting the capital from the bank itself. Because of this scenario, and given the fact that the loans are one period contract, as Chari, Jones and Manuelli (1995) points out, the firm can be seen as facing a static problem. Hence, the choice of ρ_t is irrelevant as an implication of the equilibrium condition in such a framework.

Realizing that in equilibrium $k_t = \bar{k}_t$ and assuming, without any loss of generality, that the capital stock depreciates completely each period, i.e., $\delta_k = 1$, the up-shot of the above static problem of the firm yields the following efficiency conditions:

$$k_t : A\alpha n_t^{1-\alpha} = \left(\frac{(1 + R_{Lt})}{\frac{p_t}{p_{t-1}}} \right) \quad (28)$$

$$n_t : A(1 - \alpha)k_t n_t^{-\alpha} = w_t \quad (29)$$

As given by equation (28), the production firm set the marginal product of capital equal to the real rate of rental. And equation (29) simply states that the firm hires labor up to the point where the marginal product of labor equates the real wage.

2.4 Government

The government commits to a sequence $\{T_t\}_{t=0}^{\infty}$ of transfers which are financed by seigniorage. The government's budget constraint, in nominal terms, is

$$T_t = m_t - m_{t-1} \quad (30)$$

where $m_t = m_{1t} + N \times m_{2it}$. The monetary authority targets the inflation rate. Namely, we assume that $\pi_t = \pi$, for all t . Note that, with $A\alpha n_t^{1-\alpha} = \left(\frac{(1+R_{Lt})}{\frac{p_t}{p_{t-1}}} \right)$, and $n_t = n$, in steady-state, targeting inflation also implies, targeting the nominal interest rate on loans. Given

this policy rule for the rate of inflation, the nominal quantity of money adjusts endogenously to satisfy the demand for money.

As discussed above, notable exceptions from the government budget constraint are taxes and government bonds. Though taxes have been ignored for simplicity, bonds are not included for the following technical reason: In a world of no uncertainty, incorporating government bonds in either the consumer or bank problem would imply plausible multiplicity of optimal allocations of deposits or loans and government bonds. Since the arbitrage condition would imply a relative price of one between deposits or loans and government debt. One way to incorporate government bonds is to have the financial intermediaries hold government bonds as part of obligatory reserve requirements. Or alternatively, assume that there exists a fixed ratio of government bonds to money. The conclusions of our analysis remains unchanged following such alternative specifications.

3. Equilibrium and Balanced-growth Equations

An equilibrium in this model economy is a sequence of prices $\{p_t, w_t, R_{Lt}, R_{dt}\}_{t=0}^{\infty}$, real allocations $\{c_t, n_t([1 - n_t]), k_t, i_{k_t}\}_{t=0}^{\infty}$, stocks of financial assets $\{m_t, d_t, l_t\}_{t=0}^{\infty}$, and policy variables $\{T_t, \gamma_t, \pi_t = \frac{p_t}{p_{t-1}}\}_{t=0}^{\infty}$ such that:

1. The allocations and stocks of financial assets solve the household's date- t maximization problem, (2), given prices and policy variables.
2. The stock of financial assets solve the bank's date- t profit maximization problem, (17), given prices and policy variables.

3. The real allocations solve the firm's date- t profit maximization problem, (25), given prices and policy variables.
4. The money market equilibrium condition: $m_t = p_{t+1}c_{t+1} + \gamma_t d_t$ is satisfied for all $t \geq 0$.
5. The loanable funds market equilibrium condition: $p_t k_{t+1} = l_t$ where the total supply of loans $l_t = \psi(1 - \gamma_t)d_t$ is satisfied for all $t \geq 0$.
6. The labor market equilibrium condition: $n_t^d + (1 - n_t)^d = 1$ for all $t \geq 0$.
7. The goods market equilibrium condition require: (1), $c_t + i_{kt} = Ak_t^\alpha n_t \bar{k}_t^{1-\alpha}$ is satisfied for all $t \geq 0$.
8. The Government budget is balanced on a period-by-period basis.

To study the long-run behavior of the model, we use the solutions to the maximization problems of the consumer, financial intermediary and the firm together with the equilibrium conditions to calculate the balanced growth equations. Along a balanced growth path, output grows at a constant rate. In general, for the economy to follow such a path, both the preference and the production functions must take on special forms. On the preference side, the consumer, when faced with a stationary path of interest rates must generate a demand for constant growth in consumption. The requirement is satisfied by the, above discussed, iso-elastic utility function, while, on the production side, a sufficient condition is that output is produced by a Cobb-Douglas type production function.

For the sake of tractability, we assume that the government has time invariant policy rules, which means the reserve-ratio, γ_t , besides, the rate of inflation $\pi_t = pi_{t+1} = \hat{\pi}$ for all t ,

are constant over time. Given this, the economy is characterized by the following system of balanced growth equations:

$$g^\sigma \hat{\pi} = \beta[1 + R_d] \quad (31)$$

$$\frac{\hat{m}_1}{k} = \hat{\pi} \frac{c}{k} \quad (32)$$

$$(1 - \gamma)\psi(1 + R_L) + \gamma = \left(1 + \frac{\sigma}{N}\right) (1 + R_d) \quad (33)$$

$$\{(1 - \gamma)\psi'(1 + R_L)\} \frac{\hat{d}}{N} = \frac{w}{k} \quad (34)$$

$$\{(1 - \gamma)\psi(1 + R_L) + \gamma - (1 + R_d)\} \frac{\hat{d}}{N} = \left(\frac{1 - n}{N}\right) \frac{w}{k} \quad (35)$$

$$\frac{\hat{m}_2}{k} = \gamma \frac{\hat{d}}{k} \quad (36)$$

$$\frac{1 + R_L}{\hat{\pi}} = A\alpha n^{(1-\alpha)} \quad (37)$$

$$\frac{w}{k} = A(1 - \alpha)n^{-\alpha} \quad (38)$$

$$g = \frac{\hat{l}}{k} \quad (39)$$

$$g = \frac{i_k}{k} \quad (40)$$

$$\frac{\hat{l}}{k} = (1 - \gamma)\psi \frac{\hat{d}}{k} \quad (41)$$

$$\frac{c}{k} + \frac{i_k}{k} = An^{1-\alpha} \quad (42)$$

where $g = \frac{c_{t+1}}{c_t} = \frac{i_{k,t+1}}{i_{k,t}} = \frac{k_{t+1}}{k_t} = \frac{\hat{d}_{t+1}}{\hat{d}_t} = \frac{\hat{L}_{t+1}}{\hat{L}_t} = \frac{\hat{m}_{1,t+1}}{\hat{m}_{1,t}} = \frac{\hat{m}_{2,t+1}}{\hat{m}_{2,t}} = \frac{w_{t+1}}{w_t}$ is the balanced growth rate of the economy; $\frac{c}{k}$ and $\frac{i_k}{k}$, are the long-run ratios of the respective parts of output relative to the size of the capital stock; \hat{d} ($= \frac{d}{p}$) is size of real deposit; \hat{L} ($= \frac{l}{p}$) is size of real loans; \hat{m}_i , $i=1, 2$, is the real money holdings by the households and banks, respectively to meet the cash-in-advance and cash reserve requirements; and n ($1 - n$) is the balanced growth

level of labor supply in the firm and the banking sector. This a non-linear system of twelve equations in twelve variables, g , R_d , R_L , $\frac{c}{k}$, $\frac{i_k}{k}$, $\frac{\hat{d}}{k}$, $\frac{\hat{l}}{k}$, $\frac{\hat{m}_1}{k}$, $\frac{\hat{m}_2}{k}$, w , n and N , and can be solved given the values of the policy variables π , and γ , to trace the long-run reaction of the system to a change in policy.

4. Effects of a Disinflationary Policy on Growth

We are now ready to analyze the effects of a disinflationary policy (a fall in $\hat{\pi}$) on the rate of growth. Using equations (31), (34), (35), (37), (38), (39) and (41), and realizing that ϵ ($= \frac{1-n}{N} \frac{\psi'}{\psi}$), we obtain two equations of gross growth rate (g) as a function of the size of the individual banks ($\frac{1-n}{N}$). But once the rate of growth and the size of the individual bank is determined we can obtain, R_l , R_d , w , $\frac{d}{k}$ and $\frac{l}{k}$ from the above mentioned seven equations, and the rest of the endogenous variables, $\frac{i_k}{k}$, $\frac{c}{k}$, $\frac{\hat{m}_1}{k}$, $\frac{\hat{m}_2}{k}$ and N from the equations (40), (42), (32), (33) and (41), respectively. The non-linearity of the model, does not allow us to obtain reduced forms equations for the endogenous variables, but we can still analyze the effects of a disinflationary policy graphically. Since our primary interest is the growth rate, we investigate the following two equations, obtained in the way discussed above:

$$g^\sigma = \beta[(1 - \gamma)\psi(1 - \epsilon)A\alpha n^{1-\alpha} + \frac{\gamma}{\hat{\pi}}] \quad (43)$$

$$g = \frac{1 - \alpha}{\alpha} \frac{1}{\hat{\pi}\epsilon} \left(\frac{1 - n}{n} \right) \quad (44)$$

A reduction in n , or alternatively, the development of the financial sector lowers the marginal productivity of capital, and therefore, the nominal interest rate paid to the depos-

itors. This direct effect will negatively influence the rate of growth. On the other hand, the development of the banking sector lowers the intermediation cost of capital through an increases in ψ and N , or alternatively through the size and competition effects. This results in a rise in the return of savings, and, hence, tends to increase the gross rate of economic growth. Equation (43) can, thus, be represented by a concave curve in Figure 1 drawn below. When $n=1$, we obtain the steady-state gross growth rate in the absence of any financial intermediation, which in all likelihood is negative.

Now consider equation (44), expressing the accumulation of capital. A reduction in the size of the financial sector, or an increase in n , leads to a fall in ψ and a rise in ϵ causing the gross rate of growth to fall with n . The capital accumulation equation is, thus, represented by a falling negatively-sloped curve, which approaches the vertical axis asymptotically, as represented in Figure 1 below.

Figure 1 illustrates the possibility of two interior solutions, given by points A and B, in addition to a steady-state corresponding to point C, where there is no financial intermediation activity. We have a steady-state at point C because, in the absence of labor in the financial sector, i.e., $n=1$, there is no reason for the equilization of the wage rate across the real and the banking sectors. The capital accumulation curve is, therefore, extended by the vertical segment $n=1$. The equilibrium corresponding to A is the stable one. Note that to the left (right) of point A, the real sector employs relatively small (large) part of the labor force, since the marginal productivity of labor in this region is high (low)⁶. This implies that the wage rate is higher (lower) in the real sector relative to the financial sector and the workforce shifts over to (away from) the real sector.

[INSERT FIGURE 1]

Clearly, the resulting multiple equilibria and the fact that the high-growth equilibrium (A) and the low-growth equilibrium (C) are both stable have significant implications with regard to the take-off possibility of the economy. If the economy is to reach the high-growth long-run equilibrium, the size of the financial sector has to exceed a threshold level that corresponds to the unstable equilibrium B. Therefore, with initially weak financial sector development, economic growth will be halted, the financial sector will tend to shrink and, in turn, cause the economy to converge to C. Our model, thus, indicates that, once the critical level of financial development has been achieved, the high-growth and high-welfare⁷ (stable) equilibrium will be the only available equilibrium for the economy to choose.

Note in Figure 1, we present the curves depicted by equations (43) and (44) as G_1 and G_2 , respectively. The disinflationary policy (a reduction in $\hat{\pi}$) will shift the G_1 curve upwards, while, the G_2 curve swing upwards. The shift of the G_1 curve and the swing of the G_2 curve is determined by the following two equations:

$$\frac{dg}{d\hat{\pi}} = -\frac{1}{\sigma g^{(\sigma-1)}} \beta \frac{\gamma}{\hat{\pi}^2} \quad (45)$$

$$\frac{dg}{d\hat{\pi}} = -\frac{1-\alpha}{\alpha} \frac{1}{\hat{\pi}^2 \epsilon} \left(\frac{1-n}{n} \right) \quad (46)$$

As can be observed from equation (45), the size of the shift of the G_1 curve diminishes (increases) as g increases if $\sigma > (<) 1$, given the initial reduction in $\hat{\pi}$. On the other hand, given equation (46), with financial sector development, i.e., an increase in $(1-n)$, the magnitude of the swing in the G_2 curve increases. The movements in the two curves are

represented in Figures 2 and 3. Hence, the effect on the rate of growth and the individual bank size depends on the absolute values of the shift and the swing of the G_1 and G_2 curves, respectively.

[INSERT FIGURES 2 and 3]

We will analyze the effects of the disinflationary policy at the stable equilibrium, i.e., we are assuming that the economy has reached the threshold level of financial sector development necessary to ensure the high-growth, high-welfare stable equilibrium (A). The growth rate increases, remains same or decreases, at the stable equilibrium, following a reduction in $\hat{\pi}$, iff

$$\frac{\beta\gamma}{\sigma g^{(\sigma-1)}} \begin{matrix} \geq \\ \equiv \\ < \end{matrix} \frac{1-\alpha}{\alpha\epsilon} \left(\frac{1-n}{n} \right) \quad (47)$$

The assertions made above are depicted graphically in Figures 4, 5 and 6, respectively, as given by the nature and size of movements of the G_1 and G_2 curves. Clearly, the resulting effect on the gross rate of growth is ambiguous, and depends crucially on the initial level of growth, the individual bank size, thus the level of financial sector development and the degree of competition, the degree of risk aversion and the elasticity of output with respect to capital or labor, besides the size of the discount factor and the reserve requirements. Note, a fall in $\hat{\pi}$ will also result in ambiguous effect on the size of the individual bank. Though, Figures 4, 5 and 6 indicate the mixed effect on growth accompanied by a fall in $\frac{1-n}{N}$, following disinflation, the possibility of an increase in growth rate along with an increase or unchanged individual bank size after disinflation cannot be ruled out. Figures 7 and 8 depict the scenarios, respectively. It must be pointed out that this likely to be the case at

lower levels of initial growth and individual bank size.⁸ Several other interesting observations can be made from the figures 2 and 3, and the above relationship, defined by equation (47).

[INSERT FIGURES 4, 5, 6, 7 and 8]

- Given the nature of movements of the two curves G_1 and G_2 , an economy is more likely to have a positive effect on growth following disinflation, at moderate levels of initial growth and financial sector development;
- Given the parameters, β , γ , α and σ , the condition, given by equation (47), implies that a disinflationary policy is likely to be effective, in enhancing growth rate, in an economy that achieves the same initial growth rate of another economy but with lower levels of financial sector development;
- Between two economies, the disinflationary policy will increase the rate of growth, for the economy with comparatively lower levels of growth achieved for similar levels of financial sector development, given β , γ , α and $\sigma > 1$. However, for lower degrees of risk aversion, specifically $\sigma < 1$, the result is reversed. Note that if the coefficient of relative risk aversion is unity, then the relationship is independent of the initial rate of growth;
- Given two economies with similar levels of growth rate corresponding to similar degrees of financial sector development, the economy with higher values of β , γ and α and lower values of σ , will have positive growth effects of a disinflationary policy;
- Interestingly, the model tends to suggest that economies with no reserve requirements will always be negatively influenced in terms of growth after a disinflationary policy.

However, if the initial level of financial sector development is large enough to cause the G_1 curve to slope downwards, a tight monetary policy is growth enhancing. We represent the results graphically in Figures 9 and 10, respectively.

[INSERT FIGURES 9 and 10]

5. Conclusions

Empirical evidences on the growth effects of inflation targeting, is at best, varied, with disinflationary policies observed to have significant and insignificant positive and negative effects, respectively. This paper tries to provide a theoretical justification to such ambiguity observed in the data, based on initial levels of financial sector development and growth, and degrees of relative risk aversion. Moreover, with developing and emerging market economies also adapting the inflation targeting framework, a pertinent question is what are the essential prerequisites for inflation targeting to have positive and stable growth effects in these countries. The paper also addresses the above issue by emphasizing the importance of financial sector development. In this regard, we develop a dynamic general equilibrium monetary endogenous growth model of a closed economy inhabited by consumers, firms, a Cournotian monopolistically competitive banking system, besides, an inflation-targeting monetary authority, and, in turn, analyze the effect of a tight monetary (disinflationary) policy on growth.

Our analysis indicates the possibility of multiple equilibria, and emphasizes that unless a threshold level of financial sector development is achieved, the high-growth and high-welfare (stable) equilibrium available to the economy cannot be attained. However, the

effect of lower inflation target on growth is shown to be ambiguous, with the ultimate effect depending critically on the initial level of growth, the individual bank size, thus the level of financial sector development and the degree of competition, the degree of risk aversion and the elasticity of output with respect to capital or labor, besides the size of the discount factor and the reserve requirements. In summary, results tend to suggest that, once the threshold level of financial sector has been achieved, a tight monetary policy is likely to be growth-enhancing at moderate levels of financial sector development and growth. At high initial levels of growth and financial sector development, however, a lower inflation target is more likely to increase growth for economies with relatively lesser risk averse agents. Thus, from a policy perspective, this model indicates that pursuing lower inflation targets cannot always guarantee higher growth rate, since the results would depend critically on the structural parameters of the economy.

An immediate extension of the current analysis would be to calibrate the existing model to real economies targeting inflation, and derive country-specific values for threshold level of financial sector development. This, in turn, would help drawing better policy conclusions for the particular economy studied. Moreover, the calibrated model would also help in numerically analyzing the effects of a disinflationary policy on the other endogenous variables of the model, from which some other interesting results might be obtained.

References

Apergis, N., Miller, S. M., Panethimitakis, A. & Vamvakidis, A. (2005) Inflation targeting and output growth: evidence from aggregate European data, *UCONN Working Paper Series 2005-06*, University of Connecticut.

Ball, L. & Sheridan, N. (2003) Does inflation targeting matter?, *IMF Working Paper Series 03/129*, International Monetary Fund.

Bencivenga, V. R. & Smith, B. D. (1991) Financial intermediation and endogenous growth, *Review of Economic Studies*, 58(2), pp. 195-209.

Berthélemy, J. C. & Varoudakis, A. (1997) Financial development, policy and economic growth, in: R. Lensink & and N. Hermes (Eds) *Financial Development and Growth: Theory and Experiences from Developing Countries* (London: Routledge Publications).

Chari, V. V., Manuelli, R. E. & Jones, L. E. (1995) The growth effects of monetary policy, *Federal Reserve Bank of Minneapolis Quarterly Review*, 19(4), pp. 18-32.

Dutt, A. & Ros, J. (2003) Contractionary effect of stabilization and long-run growth, *Unpublished Manuscript*, University of Norte Dame.

Espinosa, M. & Yip, C. K. (1996) An endogenous growth model of money, banking, and financial repression, *Working Paper Series 96-04*, Federal Reserve Bank of Atlanta.

Espinosa, M. & Yip, C. K. (1999) Fiscal and monetary policy interactions in an endogenous growth model with financial intermediaries, *International Economic Review*, 40(3), pp. 595-613.

Fraga, A., Goldfajn, A. & Minella, A. (2003) Inflation targeting in emerging market economies, *NBER Working Paper Series 10019*, National Bureau of Economic Research.

Kudoh, N. (2004) Debt, deficits, and deflation in an economy with central bank independence, Midwest Macroeconomics Conference, May, U.S.A.

Kudoh, N. (2004) Monetary policy and growth cycles, *Working Paper*, Kansai University.

Lavoie, M. (2002) A post Keynesian alternative to the new consensus on monetary policy, ADEK Conference, November, France.

Libanio, G. A. (2005) “Good governance” in monetary policy and negative real effects of inflation targeting in real economies, *CEDEPLAR Discussion Paper Series 277*, Federal University of Minas Gerais.

Miguel, L. & Thirlwall A. P. (2002) The endogeneity of the natural rate of growth, *Cambridge Journal of Economics*, 26(4), pp. 441-459.

Mishkin, F. (2001) From monetary targeting to inflation targeting: lessons from industrialized countries, *Policy Research working Paper 2684*, World Bank.

Mishkin, F. (2004) Can inflation targeting work in emerging market countries?, *NBER Working Paper Series 10646*, National Bureau of Economic Research.

Neumann, M. & von Hagen, J. (2002) Does inflation targeting matter?, *Federal Reserve Bank of St. Louis Review*, 84(4), pp. 127-146.

Romer, P. (1986) Increasing returns and long-run growth, *Journal of Political Economy*, 94(5), pp. 1002–1037.

Notes

¹Refer to Neumann and von Hagen (2002), Ball and Sheridan (2003), Fraga, Goldfajn and Minella (2003) and Libanio (2005) for details regarding the countries targeting inflation and the starting date of the regime.

²See Kudoh (2004a, 2004b) for details.

³See below, the firms problem, for details.

⁴See Berthélemy and Varoudakis (1997) and the references cited therein for further details.

⁵See Section 2.3 for details.

⁶Note that the marginal product of labor is infinite when $n=0$

⁷The discounted stream of welfare of the economy is captured by $\frac{U_0}{1-\beta g^{(1-\sigma)}}$, where $U_0 = \frac{c_0^{1-\sigma}}{1-\sigma}$, with U_0 and c_0 representing the initial level of consumption and utility, given the initial level of capital stock. Clearly, with $\beta g^{(1-\sigma)} < 1$, the usual condition required for the existence of the life-time utility function, the welfare level of the economy is positively related with g .

⁸However, note that given the nature of the movement of the two curves, G_1 and G_2 , it is not possible to experience a fall in growth rate and an increase in the individual bank size following a reduction in the inflation target.

Figure 1: Multiple equilibria

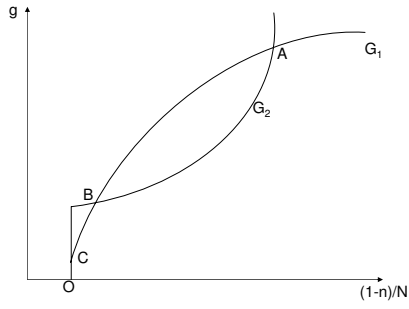

Figure 3: Swing of the G_2 curve with a reduction in $\hat{\pi}$

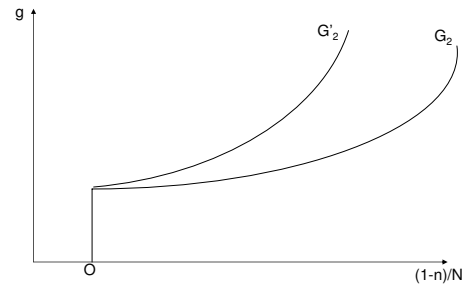

Figure 2: Shift of the G_1 curve with a reduction in $\hat{\pi}$

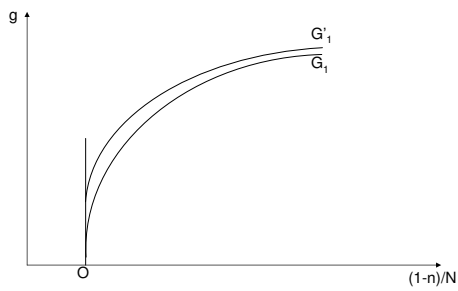

Figure 4: Growth-enhancing effect of a lower inflation target

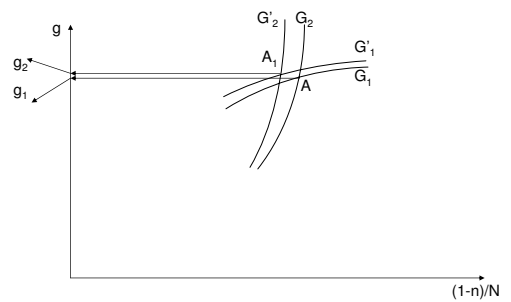

Figure 5: Growth-neutral effect of a lower inflation target

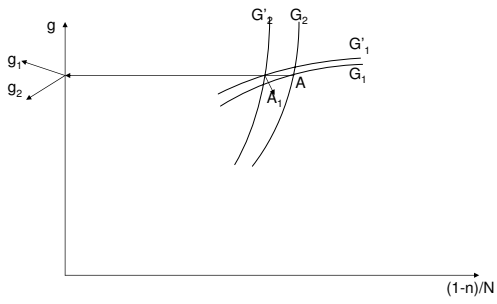

Figure 7: Growth-enhancing effect of a lower inflation target

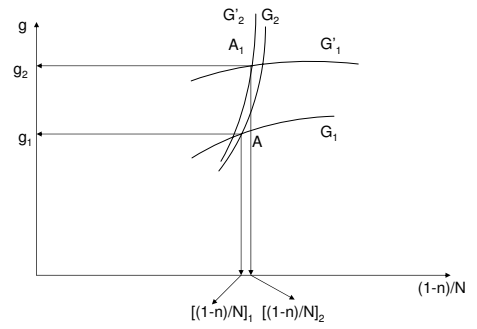

Figure 6: Growth-reducing effect of a lower inflation target

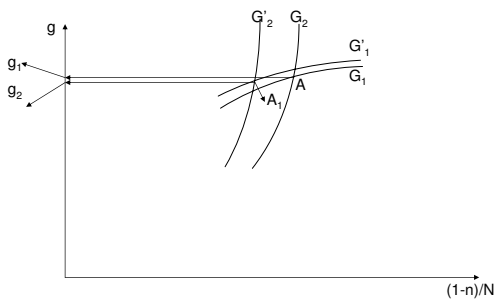

Figure 8: Growth-enhancing effect of a lower inflation target

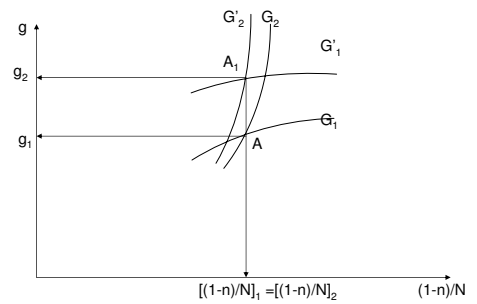

Figure 9: Growth-reducing effect of a lower inflation target with zero reserve requirement

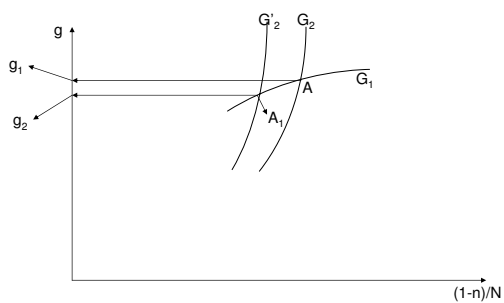

Figure 10: Growth-enhancing effect of a lower inflation target with zero reserve requirement

