

A NUMERICAL TOOL FOR THE SIMULATION OF A DIESEL SPRAY “STABILIZED COOL FLAME” REACTOR

Kolaitis D.I.* and Founti M.A.

*Author for correspondence

Laboratory of Heterogeneous Mixtures and Combustion Systems,
School of Mechanical Engineering, National Technical University of Athens,
9, Heron Polytechniou, Polytechniupoli Zografou, Athens 15780,
Greece,
E-mail: dkol@central.ntua.gr

ABSTRACT

A numerical investigation of the turbulent, multi-component and reactive flow-field that develops in a Stabilized Cool Flame Diesel fuel spray evaporation system, using a Computational Fluid Dynamics (CFD) code is presented. The physical and chemical phenomena are described by solving the respective mass, momentum, species, thermal and turbulent energy conservation equations. A dedicated numerical model is developed, based on the fitting parameter concept, in order to describe in sufficient detail the thermo-chemical effects of cool flame reactions. The model is based on physico-chemical reasoning coupled with information from available experimental data and chemical kinetics simulations. The developed model is validated and evaluated by comparing CFD predictions to experimental data from an atmospheric pressure, evaporating Diesel spray, Stabilized Cool Flame reactor. Temperature predictions are compared to measurements with satisfactory agreement. Computational results are used to obtain in-depth information about the complex flow-field developing in such innovative devices.

NOMENCLATURE

A_i	[-]	Model constants
B_i	[-]	Model constants
Q	[W/m ³]	Cool flame-induced heat release rate
T	[K]	Temperature
λ	[-]	Lambda factor (ratio of the actual air-to-fuel mass ratio over its stoichiometric value)

Subscripts

e	Experimental
CF	Cool Flame

INTRODUCTION

Liquid fuel atomization, in the form of a spray, is commonly used in a large variety of technical combustion applications such as furnaces and boilers, Internal Combustion Engines (ICE) and gas turbines in order to increase the fuel surface area and thus accelerate the evaporation and combustion rates. In conventional spray combustion systems, the incomplete mixing of the liquid fuel droplets and fuel vapours with the surrounding air leads to inhomogeneities in the mixture that may reduce the overall energy utilization and enhance the formation of pollutants. Towards achieving better mixing conditions in the air-fuel vapour mixture, a novel approach, taking advantage of the Stabilized Cool Flame (SCF) phenomenon, has been recently proposed [1]. In this case, the two main phenomena, namely droplet evaporation and fuel combustion, are essentially separated; the liquid fuel is allowed to evaporate (but not to burn) in an open-flowing chamber where low temperature oxidative cool flame reactions occur. The additional heat due to the exothermic reactions enhances droplet evaporation, resulting in the production of a highly homogeneous, heated (though not ignited) mixture of air and fuel vapour. The produced mixture can be either fed into premixed combustion devices, which allow better control over the combustion process, or utilized for reforming the fuel to a hydrogen-rich gas. Ongoing research on SCF mixture preparation suggests that this process may be used as part of a Diesel oil reforming technology for utilization in fuel cell systems [2, 3].

The present work aims to numerically investigate the interacting physico-chemical phenomena occurring inside a SCF reactor. Toward this end, a commercial Computational Fluid Dynamics (CFD) code is used to simulate the SCF device. In order to model the effects of cool flame reactions on

heat and mass transfer, a dedicated semi-empirical correlation is developed to numerically estimate the cool flame heat release rate. The model is based on physico-chemical reasoning coupled with experimental data and chemical kinetics simulations. After being implemented in the CFD code, the proposed model is validated and evaluated by comparing numerical predictions with experimental data obtained in an atmospheric pressure, Diesel spray, SCF reactor.

COOL FLAMES

Overview

Cool flames are essentially a low temperature oxidation process (500-800K) during which the fuel is only partially oxidized. Cool flames are characterized by the appearance of a faint pale bluish light, attributed to the chemiluminescence of excited formaldehyde [4]. Cool flames appear, in the form of a self-quenching temperature and pressure pulse, during the two-stage ignition of hydrocarbon fuels and are associated with the “knocking” phenomenon in ICE. Cool flame reactions occur preferentially under fuel-rich conditions and are generally exothermic in nature, producing modest amounts of heat.

During hydrocarbon fuel autoignition, the operating kinetic mechanisms governing the chemical reactions are continuously changing according to the temperature of the air-fuel mixture. As a result, it is possible to define low- and high-temperature mechanisms, in which different oxidising schemes are effective. Cool flames manifest themselves in the range of temperatures where transition between low temperature and high temperature mechanisms occurs and are dominated by exothermic degenerately branched chain reactions involving one or more important long-lived intermediates [5]. Both thermal and kinetic feedback phenomena are important in the temperature region of cool flame emergence. As a result, a competition between termination and branching reactions arises, whenever the former exhibit higher activation energies than the latter [6]. In this case, a Negative Temperature Coefficient (NTC) region emerges, corresponding to a decrease in the overall reaction rate with increasing temperature.

Stabilized Cool Flames

By exploiting the NTC phenomenon as a chemical “barrier” for autoignition [7], it is possible to “stabilize” the cool flame reactions in an open flowing system. In this case, heat losses at the system’s boundaries are balanced by heat generation owed to the exothermal chemical activity and steady-state thermochemical conditions are achieved, without being followed by “conventional” ignition. Experimental evidence suggests that when SCF are realized in an open flowing system, the air-fuel mixture temperature may increase up to 200K in the flow direction and subsequently stabilize at the raised level [1]. Only 2-10% of the fuel’s available thermal energy is being “consumed” when non-igniting SCF operation is achieved. The occurrence of atmospheric pressure Diesel oil SCF is favoured under fuel-rich conditions in the temperature range of 550-800K [8]. The utilization of the SCF phenomenon in a dedicated “liquid fuel evaporation” device, results in the

enhancement of the liquid fuel spray evaporation rate, producing a well-mixed, heated and residue-free oxidant-fuel vapour mixture. This mixture can be either subsequently burnt, utilizing premixed combustion technologies, or reformed into hydrogen-rich gas for use in fuel cells [2, 3].

Attention to cool flames has been mainly driven by the fact that they are associated with “knocking” phenomena in spark ignition ICE, therefore most of the respective studies deal with the high-temperature, high-pressure conditions prevailing inside the engine cylinder [9]. However, there is a scarcity of information regarding non-igniting SCF, both in terms of experimental investigation and of numerical modelling of the respective phenomena, especially in the frame of a CFD code. The numerical modelling of the complex interacting chemical and momentum-, heat- and mass-transfer phenomena occurring inside a SCF reactor necessitates the use of a dedicated modelling approach.

Stabilized Cool Flame Reactor

An atmospheric pressure, recirculating flow SCF reactor has been used to validate the developed cool flame model. The reactor consists of a 162.5mm long cylinder with an inner diameter of 102mm, which is attached to a 40 deg. converging nozzle with a 25mm circular outlet (Figure 1). A 54mm diameter metal disk (bluff body) is fixed at the downstream end of the cylindrical part of the reactor, in order to generate the main recirculation zone. To assist the establishment of a steady recirculation region, an inner cylinder of 80mm diameter is installed upstream the recirculation disk. The recirculation zone assists the reactor’s stability, thus allowing extending its operational point to fuel-rich conditions. A water-cooled, 60 deg. hollow cone, Simplex pressure atomizer is used for Diesel oil injection through a central 2mm circular opening, whereas the preheated air-stream enters the reactor through 8 circular holes, with a diameter of 5mm, that are circumferentially positioned at a distance of 15mm from the central axis.

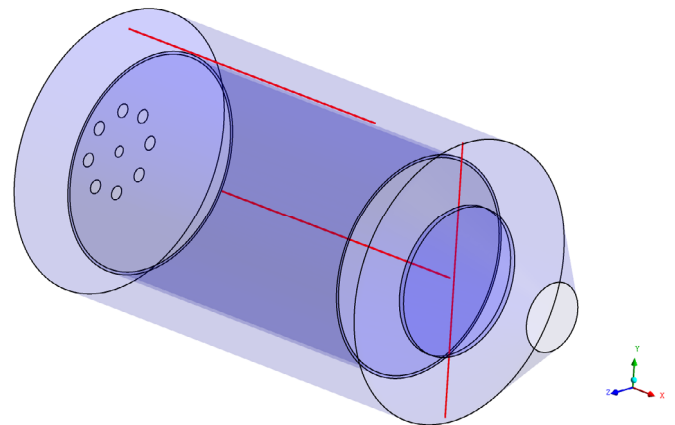

Figure 1 Sketch of SCF reactor and thermocouple positions.

The thermally insulated reactor is equipped with 3 retractable thermocouples that allow recording temperature profiles in various positions inside the reactor. The two thermocouples measuring axial profiles are positioned along the symmetry axis and the main recirculation zone, whereas an

additional thermocouple measuring the radial temperature profile is placed 1mm upstream the bluff body (Figure 1).

NUMERICAL SIMULATION

Presentation of the CFD Code

The numerical simulations are performed using the ANSYS CFX 11.0 code, which is a general purpose and widely validated CFD software suite [10]. In this study, the code is set to solve the three-dimensional partial differential equations that describe fluid flow, heat transfer and species transport. The flow is assumed to be steady, incompressible, turbulent and multi-component. Thus, the Favre-averaged equations for the conservation of mass, momentum, turbulent energy, species concentration and thermal energy are solved, using a finite control volume method based on a collocated unstructured grid arrangement. The RNG $k-\varepsilon$ model is utilized to simulate the turbulent flow [11]. A conjugate heat transfer model is also used to determine heat transfer phenomena in flow regions occupied by heat conducting solids (bluff body, recirculation cylinder).

The operating temperature levels of the SCF reactor are slightly higher than the respective Diesel oil's boiling point. As a result, the droplets are assumed to promptly evaporate as soon as they enter the reactor, thus leading to a single-phase, multi-component flow-field. The two main components of the mixture (i.e. air and Diesel oil vapour) are assumed to be mixed at the molecular level, thus sharing the same mean velocity, pressure and temperature fields; mass transfer takes place by convection and diffusion. In order to take into account the effects of cool flame chemical reactions, a dedicated heat release rate model is introduced into the CFD code by means of user-defined source terms.

Cool Flame Model

In general, cool flames are not taken into account in CFD simulations of turbulent combustion phenomena, with the sole exception of ICE in-cylinder studies, where they are implicitly dealt under the frame of the "ignition delay time" collective modelling [12]. As a result, in order to simulate a non-igniting SCF reactor utilizing a CFD code, there arises a need to develop an appropriate model. Cool flames, especially the low-temperature NTC region that is of major importance for the SCF behaviour, are considered to be a kinetically controlled phenomenon characterized by "slow" chemistry [5, 13]. Therefore, multi-step finite-rate chemical reactions have to be taken into account [13, 14]. Incorporating a detailed chemical kinetics mechanism into a multi-dimensional CFD code is still not a straightforward procedure due to both the excessive computational requirements and the shortage of relevant intermediate species measurements, necessary to serve as validating means [15]. Consequently, an alternative modelling approach is developed, aiming to formulate a simple, dedicated, low computational cost model, capable of describing with sufficient accuracy the main thermo-chemical characteristics of the SCF reactions, being at the same time suitable for incorporation in a CFD code.

The developed model is based on the "parameter fitting" technique [13], where each individual computational cell is assumed to be an "infinitely fast mixing" Perfectly Stirred Reactor (PSR) with spatially uniform temperature and mixture composition [16]. A large number of temperature measurements [8], obtained in an atmospheric pressure linear SCF reactor under fuel-lean conditions ($\lambda_e=1.27$), is utilized in order to determine local heat release rate values, by employing a thermodynamic analysis for the quantification of heat losses. As a result, a 4th order polynomial, Equation (1), is generated by applying a curve-fitting procedure [17], correlating the experimentally determined cool flame induced volumetric heat release rate $Q_e(\text{W/m}^3)$ to the mean temperature (T). The respective polynomial constants (A_i) are given in Table 1.

$$Q_e(T) = \sum_{i=0}^4 A_i T^i \quad (1)$$

$$\frac{Q_{CF}(T, \lambda)}{Q_e(T)} = B_0 + B_1 e^{B_2 \lambda} \quad (2)$$

Literature evidence suggests that an increase in the fuel concentration leads to the intensification of the overall cool flame reaction rate [9]. In order to quantify the effect of fuel concentration, a chemical kinetics mechanism is utilized aiming to formulate an appropriate correction factor, correlating the temperature-dependent experimentally obtained values, $Q_e(T)$, with the local fuel concentration (expressed via the lambda factor). Since there are no chemical kinetic schemes available for the "real" Diesel oil fuel, which is essentially a mixture consisting of a plethora of components, it is assumed that its chemical and physical properties can be sufficiently well described by n-heptane [15]. The semi-detailed kinetic mechanism of the Chalmers University [18], involving 290 reactions and 57 species, is used to perform a large number of numerical simulations, utilizing the PSR assumption. An exponential decay function is capable of reproducing very well the values obtained by the numerical experiments [19]. The developed correlation, Equation (2), enables the calculation of the local cool flame heat release rate $Q_{CF}(T, \lambda)$ as a function of both temperature and fuel concentration; the values of the corresponding constants (B_i) are given in Table 1.

Temperature range (K)	598 – 750	750 – 925
A_0	-7.426822×10^2	$+9.311440 \times 10^6$
A_1	-1.217922×10^5	-6.522844×10^3
A_2	$+4.952730 \times 10^2$	-6.206470×10^1
A_3	-6.597038×10^{-1}	$+1.126900 \times 10^{-1}$
A_4	$+2.879051 \times 10^{-4}$	-5.377180×10^{-5}
B_0	0.47154	
B_1	1.37276	
B_2	-0.76665	

Table 1 Model constants for Equations (1)-(2).

RESULTS AND DISCUSSION

The unstructured grid used for the numerical simulations comprises of 2,012,274 tetrahedral elements (Figure 2). This resolution is adequate to ensure grid independence since the flow-field obtained with this grid arrangement does not deviate more than 2% when compared to the one obtained using 2,352,827 elements. The grid is refined close to the solid boundaries in order to improve the local resolution of the developing boundary layers.

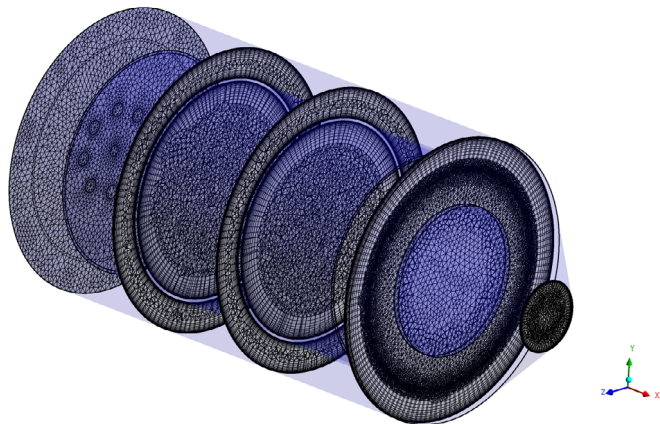

Figure 2 General numerical grid distribution.

Air, heated at 606K, is considered to enter the reactor through the 8 circumferentially distributed holes, having a top-hat velocity profile, corresponding to the experimentally determined volumetric flow rate. Diesel oil vapour is assumed to enter through the central hole, due to the utilized prompt evaporation assumption, having a top-hat velocity profile. The initial temperature of the injected vapours is assumed to be equal to the fuel's boiling point, i.e. 523K. According to fuel consumption measurements, the total liquid phase mass flux is 0.2139gr/s, yielding a mean mass loading of 5.7%, corresponding to a total power of 9.14kW and a global lambda factor value of 1.21. The reactor's well-insulated outer walls are considered adiabatic; however, for the temperature estimation of both the bluff body and of the recirculation cylinder, conjugate heat transfer is taken into account.

The complex two-phase flow-field that develops inside the SCF reactor is evident in Figure 3, which depicts predictions of the gas mixture velocity vectors. Three primary recirculation regions are developed. A minor recirculation zone is located just downstream the injection nozzle and is owed to the entrainment of air through the circumferentially distributed inlet openings. The main recirculation region is created by the bluff body disk and, assisted by the recirculation cylinder, develops in the outer zone of the reactor. Finally, a third recirculation zone appears downstream the bluff body but, due to the converging nozzle, the flow is again fully developed at the reactor's outlet.

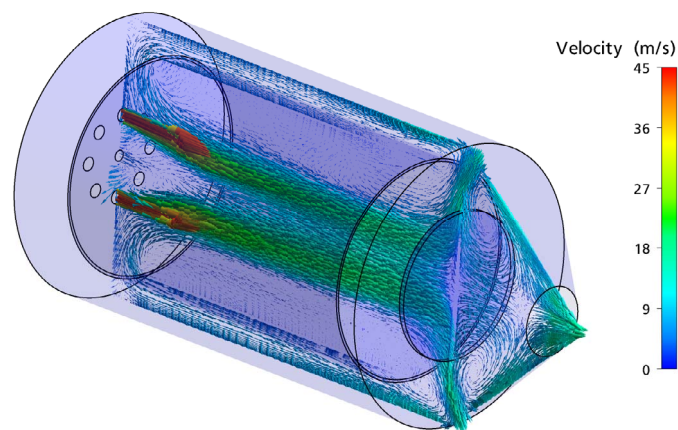

Figure 3 Predictions of gas mixture velocity vectors.

Predictions of the Diesel oil's vapour mass fraction are presented in Figure 4. It is evident that, due to turbulent mixing and diffusive and convective mass transfer phenomena, the air-vapour mixture becomes diluted, achieving homogeneous conditions at the reactor's outlet. At the current stage of model development, no fuel consumption due to cool flame reactivity is taken into account; however, a more advanced modelling approach is currently being developed to consider such phenomena.

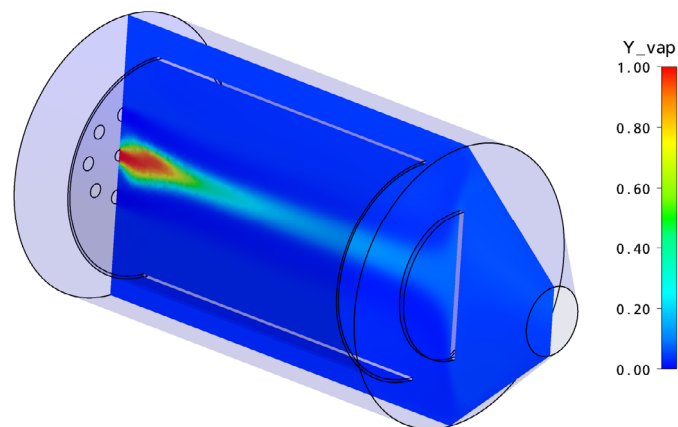

Figure 4 Predictions of Diesel oil vapour mass fraction.

In Figure 5, predictions of the cool flame-induced heat release rate are depicted. Substantial chemical activity is observed in the main recirculation region, developing in the outer part of the reactor, thus confirming its vital role in the thermo-chemical stability of the developing flow-field. Another region that exhibits high heat release rate values is the recirculation zone that emerges downstream the bluff body. In this region, the multi-component mixture is subjected to intense mixing (c.f. Figure 3), which results in the enhancement of the chemical activity. Figure 5 also reveals that, contrary to conventional combustion applications where chemical reactions occur mainly in a very "thin" flame zone, cool flame reactivity zones are highly extended and cover a significant amount of the reactor's volume.

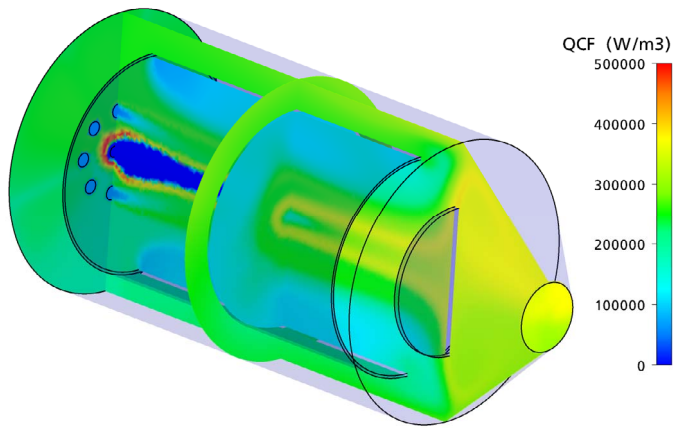

Figure 5 Predictions of cool flame heat release rate.

Temperature predictions inside the SCF reactor are presented in Figure 6. Higher temperatures are observed in the outer region of the main core of the flow, due to the combined influence of the adjacent recirculation cylinder, which is maintained in high temperature and the low velocity field that contributes in locally “freezing” the flow. Outlet temperature values are of the order of 720K; as a result, a homogeneous, heated (yet below ignition temperature) air-fuel vapour mixture is produced, which can be subsequently used either in premixed combustion devices or for fuel reforming applications.

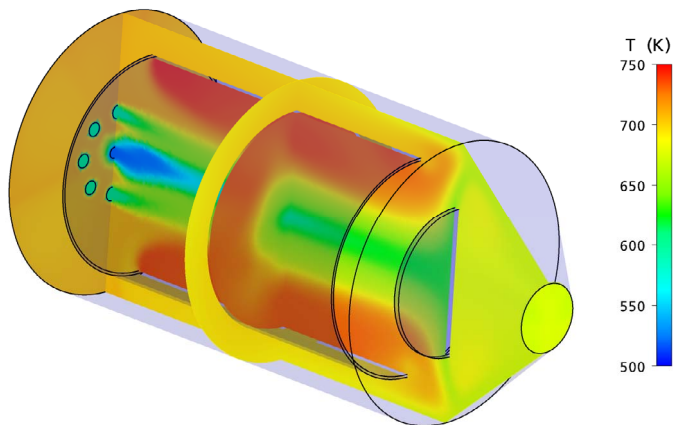

Figure 6 Predictions of mixture temperature.

Validation of the Results

In Figure 7, temperature predictions along the reactor’s symmetry axis ($r=0\text{mm}$) are compared to available experimental data [20]. The thermal field inside the SCF reactor features the following characteristics: downstream the fuel injection plane, the droplets, subjected to the surrounding preheated air environment, promptly evaporate; the emerging fuel vapours sustain the cool flame exothermal reactions, which lead to an increase in the mean temperature. Steady-state operation is achieved since a nearly constant temperature is observed throughout the reactor’s core without, however, the mixture being “conventionally” ignited and burnt.

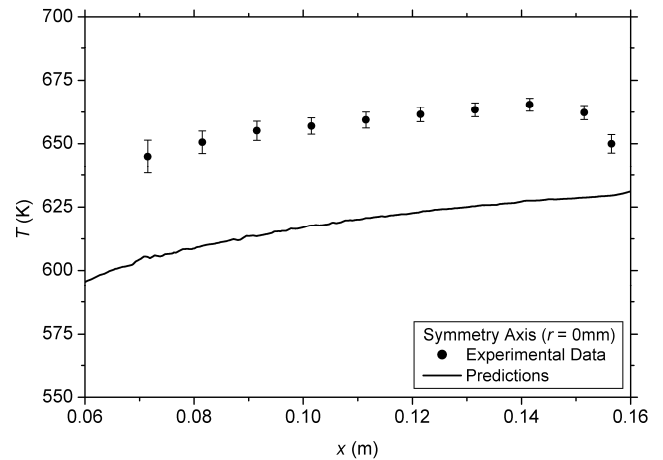

Figure 7 Comparison of predictions with temperature measurements along the symmetry axis ($r=0\text{mm}$).

Numerical results are found to under-predict the observed temperature values by 30-40K, although the general trend is qualitatively similar. The observed discrepancies are mainly attributed to the utilized prompt droplet evaporation assumption that leads to the introduction of a low-temperature gaseous jet, which results in an “artificial” decrease of the mean temperatures observed near the symmetry axis.

A considerably better agreement is achieved in the main recirculation region ($r=46\text{mm}$), where no liquid droplets exist in the actual SCF reactor (Figure 8). In this case, a slight over-prediction is observed, which is attributed to the adiabatic boundary conditions utilized for the outer reactor’s walls. However, the obtained numerical results lie very close to the available experimental data, despite the complexity of the occurring physico-chemical phenomena and the simplifying assumptions that were made to formulate the simulation.

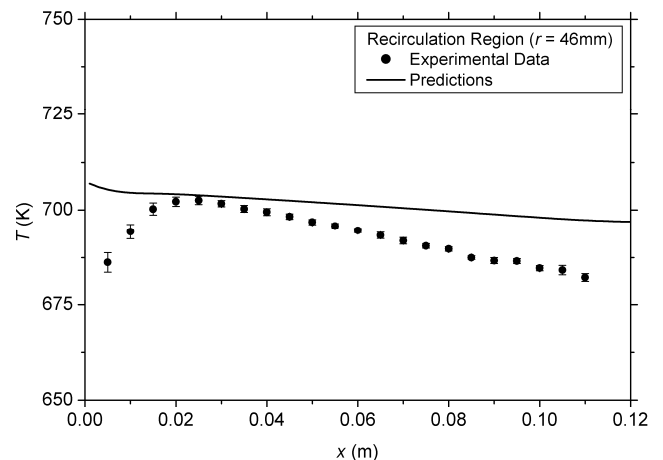

Figure 8 Comparison of predictions with temperature measurements along the main recirculation region ($r=46\text{mm}$).

In Figure 9, predictions are compared to the measured radial temperature profile, 1mm upstream the bluff body disk. Once more, reasonable qualitative and quantitative agreement is observed, given that the mean error does not exceed 25K. In

this case, conjugate heat transfer phenomena play an important role since the surface temperature of the bluff body is strongly dependent on the developing thermal field.

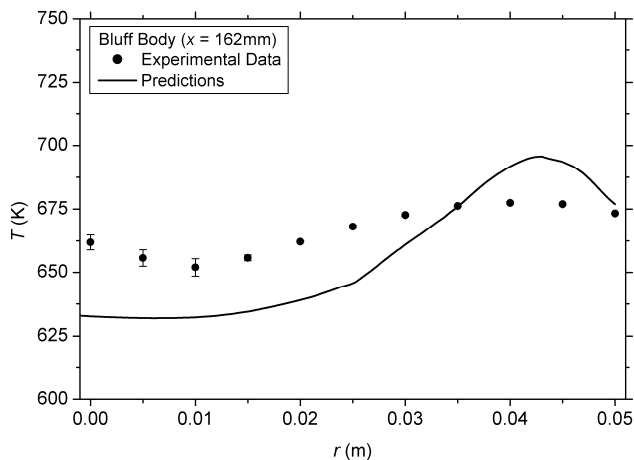

Figure 9 Comparison of numerical results with temperature measurements across the bluff body ($x=162\text{mm}$).

CONCLUSION

A dedicated modelling approach, based on the “parameter fitting” technique, has been developed and assessed in order to numerically simulate the SCF phenomenon, utilizing a commercial CFD code, in a non-igniting, atmospheric pressure, Diesel oil reactor. The cool flame model has been derived using an algebraic expression deduced from experimental data correlating cool flame heat release rates with temperature. The model has been further improved by utilizing a chemical kinetics mechanism, in order to take into account the effects of fuel concentration variations. The developed model has proved to be particularly convenient for use in the context of a CFD code. Validation tests in a recirculating flow SCF reactor showed that the developed computational model exhibits an encouraging performance, yielding results within a satisfactory level of accuracy. Major flow features and the cool flame-induced heat release characteristics have been well reproduced, thus enabling the utilization of the developed numerical tool for the investigation of the thermal behaviour of SCF reactors.

The absence of velocity field experiments to characterize the developing highly recirculating flow inside the reactor prohibits its computational validation. However, when predictions are compared to gas mixture temperature measurements, only minor discrepancies are observed. The latter are mainly attributed to the utilization of the “prompt” droplet evaporation assumption; ongoing research work is focused towards relaxing this assumption.

REFERENCES

[1] Lucka K. and Koehne H., Usage of cold flames for the evaporation of liquid fuels, *Proceedings of the 5th Int. Conf. On Technologies*

- and Combustion for a Clean Environment*, Lisbon, Portugal, Vol. 1, 207-213, 12-15 July, 1999
- [2] Hartmann L., Lucka K. and Koehne H., Mixture preparation by cool flames for diesel-reforming technologies, *J. Power Sources*, Vol. 118, 2003, pp. 286-297
- [3] Naidja A., Krishna C.R., Butcher T. and Mahajan D., Cool flame partial oxidation and its role in combustion and reforming of fuels for fuel cell systems, *Prog. Energy Combust. Sci.*, Vol. 29, 2003, pp. 155-191
- [4] Sheinson R.S. and Williams F.W., Chemiluminescence Spectra from Cool and Blue Flames: Electronically Excited Formaldehyde, *Combust. Flame*, Vol. 21, 1973, pp. 221-230
- [5] Lignola P.G. and Reverchon E., Cool Flames, *Prog. Energy Combust. Sci.*, Vol. 13, 1987, pp. 75-96
- [6] Griffiths J.F., Reduced Kinetic Models and their Application to Practical Combustion Systems, *Prog. Energy Combust. Sci.*, Vol. 21, 1995, pp. 25-107
- [7] Gray B.G. and Felton P.G., Low-Temperature Oxidation in a Stirred-Flow Reactor-I. Propane, *Combust. Flame*, Vol. 23, 1974, pp. 295-304
- [8] Steinbach N., Untersuchungen zum Zuendverhalten von Heizoeel EL-Luft-Gemischen unter atmosphaerischem Druck, *Ph.D. Thesis*, RWTH-Aachen, Germany, 2002.
- [9] Aggarwal S.K., A Review of Spray Ignition Phenomena: Present Status and Future Research, *Prog. Energy Combust. Sci.*, Vol. 24, 1998, pp. 565-600
- [10] ANSYS CFX, Release 11.0 User’s Manual, 2006
- [11] Yakhot V., Orszag S.A., Thangam S., Gatski T.B. and Speziale C.G., Development of turbulence models for shear flows by a double expansion technique, *Phys. Fluids A*, Vol. 4, 1992, pp. 1510-1520
- [12] Colin O., da Cruz A. P. and Jay S., Detailed chemistry-based auto-ignition model including low temperature phenomena applied to 3-D engine calculations, *Proceedings of the Combustion Institute*, Vol. 30, 2005, pp. 2649–2656
- [13] Pilling M.J. (Ed.), *Low-Temperature Combustion and Autoignition*, Comprehensive Chemical Kinetics, Vol. 35, Elsevier, Amsterdam, 1997.
- [14] Kolaitis D.I. and Founti M.A., Cool Flame Behaviour of n-Heptane: A Comparative Study of Kinetic Mechanisms, *Proceedings of the 3rd European Combustion Meeting*, Chania, Greece, Paper 21-6, 11-13 April, 2007.
- [15] Montgomery C.J., Cremer M.A., Chen J.Y., Westbrook C.K. and Maurice L.Q., Reduced Chemical Kinetic Mechanisms for Hydrocarbon Fuels, *J. Propul. Power*, Vol. 18, 2002, pp. 192-198
- [16] Kong S.C., Marriott C.D., Reitz R.D. and Christensen M., Modeling and Experiments of HCCI Engine Combustion Using Detailed Chemical Kinetics with Multidimensional CFD, *SAE Proceedings*, 2001, Paper No. 2001-01-1026
- [17] Founti M.A. and Kolaitis D.I., Numerical simulation of diesel spray evaporation exploiting the “stabilized cool flame” phenomenon, *Atomization Spray*, Vol. 15, 2005, pp. 1-18
- [18] Tao F., Golovitchev V.I. and Chomiak J., A phenomenological model for the prediction of soot formation in diesel spray combustion, *Combust. Flame*, Vol. 136, 2004, pp. 270-282
- [19] Kolaitis D.I. and Founti M.A., Numerical modelling of transport phenomena in a diesel spray “stabilized cool flame” vaporizer, *Combust. Sci. Technol.*, Vol. 178, 2006, pp. 1087-1115
- [20] Kolaitis D.I. and Founti M.A., Numerical Simulation of Diesel Spray Evaporation in a “Stabilized Cool Flame” Reactor: A Comparative Study, *Proceedings of Computational Combustion 2007 - ECCOMAS Thematic Conference*, Delft, The Netherlands, Paper 0302-022, 18-20 July, 2007.