



Geology of the Palaeoproterozoic Daspoort Formation (Pretoria Group, Transvaal Supergroup), South Africa

Reynard Dirk Bartman

Submitted in partial fulfilment of the requirements for the degree

MASTER OF SCIENCE

In the

Department of Geology

Faculty of Natural and Agricultural Sciences

University of Pretoria

December 2013

ABSTRACT

This thesis examines the geology of the Daspoort Formation (Pretoria Group, Transvaal Supergroup) of South Africa, with the accent on describing and interpreting its sedimentology. The Palaeoproterozoic Daspoort Formation (c. 2.1-2.2 Ga) forms part of the Pretoria Group on the Kaapvaal craton. This sandstone- and quartzite-dominated lithological formation covers an elliptical geographical area stretching from the Botswana border in the west to the Drakensberg escarpment in the east, with its northern limit in the Mokopane (Potgietersrus) area and Pretoria in the south; altered outliers are also found in the overturned units of the Vredefort dome in the Potchefstroom area. Deposition of the Daspoort Formation was in a postulated intracratonic basin which applies equally to the entire Transvaal Supergroup succession in the Transvaal depository. Various characteristics from the formation, such as sedimentary architectural elements (e.g., channel-fills etc.), maturity trends and distribution of lithofacies assemblages across the preserved basin give insight into the developing conditions during deposition and genesis of the Daspoort Formation. Subordinate evidence from basic geochemistry, ripple mark data and optical microscope petrology studies support the sedimentary setting inferred for this Palaeoproterozoic deposit. Fluvial and epeiric marine conditions prevailed during the deposition of the Daspoort clastic sediments into the intracratonic basin. This shallow epeiric sea was fed by fluvial influx, predominantly from the west when a transgressive regional systems tract led to the filling of the basin, evolving into the deeper marine Silverton Formation setting, laid down above the Daspoort. Transgression from the east (marine facies predominate) to the west (fluvial facies) is supported by cyclical trends, palaeoenvironmental and palaeogeographical interpretations. Accompanying poorly preserved microbial mat features contribute to the postulated shallow marine environment envisaged for the eastern part of the basin whereas ripple marks and grain size distribution support a fluvial setting for the west, with lithofacies assemblages accounting for both areas' depositional interpretation.

PREFACE

I, **Reynard Dirk Bartman**, submit this thesis in fulfilment of the requirements for the degree of Master of Science in Geology. The work detailed in this study was carried out by me under the supervision of Professor Patrick G. Eriksson and Professor Adam J. Bumby. This project was funded in its entirety by the University of Pretoria and was undertaken by the author between January 2009 and December 2013.

The dissertation represents original work by the author, except where suitably acknowledged, and has not been submitted in any form for a degree at any other tertiary institution.

Name: Reynard Dirk Bartman

Signed: _____

Date: 17 December 2013

ACKNOWLEDGEMENTS

Supervisors – Patrick G. Eriksson and Adam J. Bumby

I am grateful to the University of Pretoria (UP) and the National Research Foundation (NRF) who funded this dissertation. I am very thankful to Professors Patrick G. Eriksson and Adam J. Bumby who tirelessly went through various editing phases and patiently encouraged the write-up and completion of the dissertation.

A special thanks to Thino Rajab, Ingrid Booysen and her team for the creative imagery. Wiebke Grote from the Geology Department of the University of Pretoria who provided the XRD analyses of the rock samples must also get a special appreciation as well as the technical staff who created the polished thin sections.

I also thank my family, friends and geology acquaintances, especially Pieter Koegelenberg, Johann Conradie, Karl Olivier and Francois Smuts, for their input, reviews and prayers in their continued support during the unstable years of completing this dissertation. I have a special word of thanks to my lovely girlfriend at the time, Lo-Mari Visser, which supported me through the final stages of the completion of this dissertation.

This dissertation is dedicated to my uncle, Carl Dirk Winterbach, a retired geologist, who inspired and gave me invaluable insight into the world of geology.

Lastly, but most important, I would like to give all glory to God, who gave me the perseverance, knowledge and love for nature in order to complete this personal goal.

TABLE OF CONTENTS

CHAPTER 1: INTRODUCTION		19
1.1	Aims	19
1.2	Location of study area	19
1.3	Geological setting/General geology	19
1.4	Methods	26
1.5	Previous work	27
1.6	Previous work: Lithofacies identified by previous workers	28
1.6.1	Pebbly sandstone	28
1.6.2	Fe-rich sandstone	28
1.6.3	Mudrock	28
1.6.4	Cross-bedded sandstone	29
1.6.5	Horizontally laminated sandstone	29
CHAPTER 2: REGIONAL CHARACTERISTICS		30
2.1	Thickness trends and facies relationships	30
2.2	Facies association	43
2.2.1	Pebbly lithologies	46
2.3	Palaeocurrents	49
2.3.1	Ripple marks	53
2.4	Petrography	59
2.5	Geochemistry	61
2.6	Microbial mat features in clastic sedimentary rocks	64
2.6.1	Kinneyia Structures	64
2.6.2	Petee ridges/filled cracks	70
CHAPTER 3: LITHOFACIES		76
3.1	Petrography	76
3.2	Sandstone maturity	79
3.3	Pebbly sandstone facies assemblage (arkose to lithic arenite facies)	81
3.3.1	Conglomerates (sub-facies assemblage of Pebbly sandstones)	82

3.4	Mudrock facies assemblage	84
3.4.1	Fe-rich sandstones (sub-facies assemblage of Mudrocks)	87
3.5	Cross-bedded sandstone facies assemblage	89
3.5.1	Trough cross-bedded sandstone sub-facies assemblage	89
3.5.2	Planar cross-bedded sandstone sub-facies assemblage	92
3.6	Horizontally laminated sandstone facies assemblage	94
3.6.1	Massive sandstone (sub-facies assemblage of Horizontal laminated sandstone)	95
3.7	Ripple marks	99
3.8	Lithofacies relationships	102
CHAPTER 4: DISCUSSION		108
4.1	Sedimentation/Uniformitarianism	108
4.2	Stratigraphic setting and structure	111
4.3	Lithofacies	115
4.4	Regional Patterns	118
4.4.1	Sequence Stratigraphy	121
4.5	Palaeocurrents	129
4.6	Previous work	130
4.7	Microbial mat features	131
4.8	Gabon fossils and the Great oxidation event (GOE)	134
4.9	Geochemistry	138
4.10	Thickness relationships	142
4.11	Ripple marks	144
4.12	Optical Petrology	149
4.13	Comparison of models: Previous work	150
4.14	Summary	153
CHAPTER 5: CONCLUSION		155
CHAPTER 6: REFERENCES		157
CHAPTER 7: APPENDICES		170

LIST OF FIGURES

CHAPTER 1

Figure 1.1: The occurrence of the Daspoort Formation in South Africa. Insert: The total extent of the Pretoria Group of the Transvaal Supergroup on the Kaapvaal craton is indicated in green. Modified after Parizot et al., 2005. 20

Figure 1.2: Summary of stratigraphy, geochronology, inferred base level changes, depositional palaeoenvironments and tectonic settings for the Transvaal Supergroup in the Transvaal basin (modified after Catuneanu and Eriksson, 1999; Eriksson et al., 2001; in Eriksson et al., 2005). 22

Figure 1.3: Sequence stratigraphic model for the Pretoria Group; note that this figure is not drawn to scale, but that the vertical axis suggests both time and thickness. Arrows in the column headed “sequence stratigraphy” indicate directions of shoreline transgression. Abbreviations used: LST = 2nd order lowstand systems tract; TST = 2nd order transgressive systems tract; HST = 2nd order highstand systems tract; FSST = 2nd order falling stage systems tract. Modified after Catuneanu and Eriksson (1999); in Eriksson et al., 2005. 25

CHAPTER 2

Figure 2.1: Relative thicknesses of the Daspoort Formation in outcrops and boreholes (marked by white circles) across the study area. Relative thicknesses from the Vredefort area are omitted as this area was not part of the author’s field observations. 32

Figure 2.2: New data and literature data provide isopach thickness plot of the Daspoort Formation. Note the basin’s gradual eastern thickness changes compared to the much steeper alterations in the western part. The author’s contribution is reflected by outcrop data. 33

Figure 2.3: Vertical profiles generated from outcrops in the central Daspoort basin. The squares indicate outcrop localities (vertical profiles) of the Daspoort Formation. Each bar next to the vertical profile represents 4 m. i.e. the Nkwe succession is 28 m. 37

Figure 2.4: Vertical profiles generated from outcrops in the eastern Daspoort basin. The squares indicate outcrop localities (vertical profiles) of the Daspoort Formation. Each bar next to the vertical profile represents 4 m. i.e. the Kaalbooi succession is 42 m and Sterkspruit is 48 m. Suikerboschfontein has a bar scale of 7 m. 38

Figure 2.5: Vertical profiles generated from outcrops in the western Daspoort basin. The squares indicate outcrop localities (vertical profiles) of the Daspoort Formation. Each bar next to the vertical profile represents 4 m. i.e. the Saartjiesnek succession is 76 m. It is only the Scheerpoort succession whose scale is different; each bar representing 6 m. 39

Figure 2.6: Sandstone maturity distribution in the Daspoort basin. Areas outside the outcrop perimeter are interpreted lateral distributions of lithologies. The interpolation is based on slope, strike and dip angles of Daspoort Formation outcrop on a regional scale. 40

Figure 2.7: The Proterozoic Groups displayed as a unit draped around the Johannesburg Dome. Note the resulting fault lines forming a radial pattern stemming outward from the Johannesburg Dome. 41

Figure 2.8: Another view of the Pretoria Group sedimentary rocks curving around the Johannesburg Dome (igneous Archaean rocks). The Daspoort Formation is part of the Witwatersberg mountain range west of Pretoria compared to the softer sloped ridge east of Pretoria. 42

Figure 2.9: Pie chart of Daspoort Formation's sandstone composition; based on measured profiles and outcrops across the basin. 43

Figure 2.10: Petrographic composition of samples from 3 of the 4 described major facies assemblages, Daspoort Formation. Sub-facies assemblages are not portrayed in this figure. The fourth major facies assemblage, Mudrock, does not conform to this sandstone classification. Classification after Pettijohn et al., 1972. 44

Figure 2.11: Silica pebbles found near Faerie Glen. Note the striation marks. 47

Figure 2.12: Thin horizontally laminated beds exposed in a step-like manner. Flattened sole marks and subrounded clast remnants on the bedding planes indicate coarse fragments transported in a high energy environment. 48

Figure 2.13: Various pebble sizes left imprints on the bedding plane. Their shapes also differ from one another. This is indicative of a high turbulent nature of the palaeo-environment. 48

Figure 2.14: Coarse sandstone overlain by an even coarser shell-like mud clast-bearing unit. Photo taken at Mothlabeng. 48

- Figure 2.15:** Very coarse planar cross-bedded sandstone near Hekpoort. Note the trough cross-bedding below the pen. 48
- Figure 2.16:** Ripple marks indicate transport direction from the south-east. 50
- Figure 2.17:** Ripple marks indicating various flow regimes for the western basin. The predominant direction of flow is towards the east north-east (ENE). 51
- Figure 2.18:** Ripple marks indicating flow directions towards the north in the central basin. Subordinate regimes are evident as well. 52
- Figure 2.19:** The basic concept of a wave. 53
- Figure 2.20:** Different ripple marks formed due to different flow regimes. On the left is an example of asymmetrical ripples and the right symmetrical ripples. Images acquired from Florida State University Geology notes (*see <http://www.gly.fsu.edu/~salters/GLY1000/11Sed>*). 54
- Figure 2.21:** Average ripple mark size distribution and estimated water depth across the Daspoort Formation. The photos indicate approximate ripple mark sizes. The ripple marks at Kaalbooi (top left) are the biggest found in the Daspoort Formation (wavelength <60cm). 58
- Figure 2.22 (left):** Poorly sorted, immature sandstone from the central basin. Note the various grain sizes and grain boundary overgrowth rims. 59
- Figure 2.23 (right):** Mature quartzite from Saartjiesnek. Secondary sericitic weathering products are seen in between well compacted silica grains. Microscopic view: crossed polarized light. 59
- Figure 2.24 (left):** Bimodal grain properties observed in the Hekpoort site lithic wackes. Variable sizes, degrees of alteration and shapes (smooth and angular) are evident. 61
- Figure 2.25 (right):** Transitional grain boundaries in altered sandstone of the Hekpoort area. Microscopic view: cross polarized light. 61
- Figure 2.26:** Symmetrical ripple marks covered by a thin cracked sandstone layer (petee ridges), interpreted to reflect a pre-existing microbial mat, near Mothlabeng. 62
- Figure 2.27:** Elephant skin texture on a thin bedding surface near Nkwe. 65

- Figure 2.28:** A mat-related structure found on a bedding surface at Nkwe. The flap tops of the circular features are reminiscent of weathering. This could be remnants of trace fossils or ‘foam marks’ as referred to by Porada et al., 2007. Pflüger (1999) suggested that wrinkle structures (Kinneyia in this case) formed underneath microbial mats as a result gases developing from buried, decaying mats. These structures were also referred to as moving-foam marks (Allen, 1966; Wunderlich, 1970) and small-scale interference ripples (e.g. Shrock, 1948; Mckee, 1954; Kummel and Teichert, 1970). 65
- Figure 2.29:** Possibly biotic (mat-related?) subrounded voids in hard quartzite. No *in situ* clays, pellets nor signs of other biological activity were seen. This mat-related feature is similar to Mata and Bottjer’s (2009) description of wrinkle structures. 67
- Figure 2.30:** Close-up view of abovementioned. Note the different orders (layers) of this strange texture. This feature is similar to *Kinneyia* structures found in Namibia. 68
- Figure 2.31:** Circular imprints with tail-like features connected leaving a sandy ‘spoor’. 69
- Figure 2.32:** An elongated imprint with scattered circular depressions, similar to previous image. Towards the right a positive structure is seen with similar composition as the surrounding sandstone. 69
- Figure 2.33:** The 2.1 billion year old Gabon fossils. Photo taken by El Albani (2010). Scale bar, 1.5cm. 70
- Figure 2.34:** Dark microbial mat structure with pen indicating current flow direction. 71
- Figure 2.35:** Features found in sandstones where microbial mats flourished in the past: Genetic processes are arranged clockwise along a continuum from active growth of mats to final destruction during diagenesis. Modified after Schieber (2004; his figure 7.9-1). 73
- Figure 2.36:** Suspected microbial mat features near Carolina. Note the 3 orders of petees, with the lower bed containing the best preserved adhesive sand features at the top of the photo, with the last bed represented by the slightly muddy brown triangle left of the compass. 74
- Figure 2.37:** The 1cm thick mat feature underlain by coarse arkosic sandstone with arenite displaying the grey lithology at the bottom. 74

Figure 2.38: Petee ridges, but here the host rock material is muddier than above. Also near Carolina. 75

Figure 2.39: Petee ridges close-up. Note the erratic pattern compared to the smooth curves of the other outcrop, located barely 500 m apart. 75

CHAPTER 3

Figure 3.1: Sandstone classification according to composition, matrix content and minerals present. Modified after Pettijohn (1954). 76

Figure 3.2: Sandstone classification after Dott (1964) and Boggs (2006). Note that the three major sandstone facies assemblages are concentrated towards the quartz arenite corner while the mudrock assemblage tends to lean more towards the lithic wacke and mudrock compositional regions. See text for sub-facies discussions. F = feldspars; RF = rock fragments, lithic grains, unstable; Q = quartz, chert, quartzite fragments. Points within the triangles are representative of relative proportions of Q, F and RF end members. 78

Figure 3.3: Typical thin section of Daspoort sandstone. Note generally equant grain shapes, good sorting, medium rounding (with overgrowths) and minor interstitial matrix minerals between dominant, bigger quartz grains. Microscopic view: Crossed polarised light. 80

Figure 3.4: Pebbly sandstone from Mothlabeng, western Daspoort basin. Note the bimodal grain sizes. 81

Figure 3.5: Conglomerate in Faerie Glen. 83

Figure 3.6: Conglomerate classification after Nelson (2000). 84

Figure 3.7: The lower Daspoort Formation in Pretoria consists of parallel laminated sandstone alternating with mudrocks, which become predominant towards the underlying mudstones of the Strubenkop Formation. Person for scale. 85

Figure 3.8: Mudcracks binding the weathering surface at Suikerboschfontein, Mpumalanga. 86

Figure 3.9: Iron-rich cement cutting through the bedding of the Fe-rich sandstones of the eastern Daspoort Formation. This is similar to Liesegang rings, except for the angular features. 86

- Figure 3.10:** Large scale asymmetrical ripples on a Fe-rich sandstone near Machadodorp in the south-eastern region of the basin. Stone wall for scale. Insert indicates the ripple marks on a smaller scale. 88
- Figure 3.11:** Load marks with angular troughs directed away from the observer. This is indicative of the transport direction. The casts are remnants of cubic Halite mineralization. 88
- Figure 3.12:** A mudrock layer on sandstone with compressed sand grains scattered in the muddy matrix. Underlying this layer is arkosic sandstone from the central Pretoria area. These layers often resemble a weathering surface. Negative weathering features are common in this layer which usually appears in the upper Daspoort sandstone units. 89
- Figure 3.13:** Trough cross-bedding exemplified by very coarse sandstone foresets within a finer sandstone matrix. Photo taken at Koster. Pen for scale. 90
- Figure 3.14:** Koster area cross-section. Grey areas display massive arkosic arenites (channel-fills?). Block (a) represents trough cross bedding (Figure 3.13) while block (b) is indicative of the horizontally laminated sandstone facies in the same road cutting north of Koster. 91
- Figure 3.15:** Concretions in the Hekpoort area. 92
- Figure 3.16:** Ripple marks in the Hekpoort area. 90
- Figure 3.17:** Planar cross-bedding in Pretoria associated with quartzite. Pen for scale. 93
- Figure 3.18 (left):** Planar cross-bedding (bottom) and trough cross-bedding in medium grained sandstone on the outskirts of Pretoria. Pen for scale. 94
- Figure 3.19 (Right):** Recrystallised quartz bands in dark quartzite also showing cross-bedding at Faerie Glen (Pretoria East). 94
- Figure 3.20:** Concretions in the massive sandstone at Saartjiesnek, west of Pretoria. Halos are present. 97
- Figure 3.21:** Recrystallised horizontal quartz bands in quartzitic sandstone at Saartjiesnek. Pen for scale. 98
- Figure 3.22:** Finely horizontally laminated sandstone at Faerie Glen. Pen for scale. 98

- Figure 3.23 (left):** Symmetrical wave ripples on the eastern outskirts of Pretoria. Plant leaves approximately 3 cm long. Photo courtesy of Lo-Mari Visser. 99
- Figure 3.24 (right):** Elephant skin weathered sand layer at the eastern outskirts of Pretoria. Pen for scale. 99
- Figure 3.25:** Asymmetrical ripples near Nkwe Ridge Observatory, east of Pretoria. 100
- Figure 3.26:** Ripple mark distribution across the Daspoort Formation, using Tanner’s (1967) method to distinguish between waves, current, swash and wind generated ripple marks. 101
- Figure 3.27:** Grain size distribution across the Daspoort basin. In the legend, fines refer to the mudrock facies assemblage. The two quartz grain descriptions can be linked to the cross-bedded and horizontal laminated sandstone facies assemblages. Pebbles are associated with the pebbly sandstone lithofacies assemblage. The boundaries of the lithofacies distribution are only interpreted correlations done, using old borehole information, field outcrops and previous authors’ descriptions of the lithologies found in the area. One can only speculate on the lithofacies composition of the Daspoort Formation in the central basin area and regions where outcrops are poorly preserved or non-existent. 106
- Figure 3.28:** Daspoort Formation outcrop distribution seen in vertical profiles and lithological descriptions of borehole information. Borehole information is acquired from Eriksson (1993). Outcrop thicknesses are also noted. The numerics indicate Daspoort Formation thicknesses. 107
- CHAPTER 4**
- Figure 4.1:** . Schematic summary time chart, showing main influences on Earth evolution and sedimentation from c. 4.4 Ga to 1.6 Ga. Modified after Eriksson et al. 2004. 109
- Figure 4.2:** The classic Shaw (1964)–Irwin (1965) epeiric sea model. After Eriksson et al., 2008. **Error! Bookn**
- Figure 4.3:** The sedimentary model for the Silverton-Magaliesberg shallow marine environment (an epeiric sea model). Modified after Eriksson et al., (2002); in Parizot et al., 2005. It is envisaged that the Daspoort Formation had similar fluvial (from the west) and tidal (from the east) influences. 114
- Figure 4.4:** Fluvial Braidplain model envisaged by Eriksson et al., 1993. 119

Figure 4.5: A conceptual diagram showing the two third-order systems tracts of the Daspoort Formation. Drawing is not to scale. The high accommodation systems tract (lower Daspoort) includes the sandstone and mudrock-ironstone facies associations, and is interpreted to have formed during a time of relatively high rates of base level rise. The low accommodation systems tract (upper Daspoort) includes the pebbly sandstone facies association, and is interpreted to have formed during a time of relatively low rates of base level rise. The two systems tracts are separated by a subaerial unconformity (third-order base level fall) that locally incises through the entire lower Daspoort deposits. Modified after Eriksson et al., 2004. 122

Figure 4.6: Controls on accommodation and shoreline shifts in a marine environment. The ‘DATUM’ is a reference horizon, independent of sedimentation, which monitors tectonic motions (subsidence, uplift) relative to the centre of the Earth. Modified after Catuneanu (2006). 125

Figure 4.7: Regional architecture of depositional systems, systems tracts and sequence stratigraphic surfaces (from Catuneanu, 2006). The systems tract nomenclature follows the scheme of Hunt and Tucker (1992). Systems tracts are defined by strata stacking patterns and bounding surfaces, with an inferred timing relative to the reference curve of base-level changes at the shoreline. Acquired from Atlas of microbial mat features preserved within the clastic rock record, Schieber, J., Bose, P.K., Eriksson, P.G., Banerjee, S., Sarkar, S., Altermann, W., and Catuneanu, O., (Eds.), Elsevier, p. 276 – 283. (2007). 126

Figure 4.8: Sequence stratigraphic model for the Pretoria Group; note that this figure is not drawn to scale, but that the vertical axis suggests both time and thickness. Arrows in the column headed “sequence stratigraphy” indicate directions of shoreline transgression. The Daspoort Formation, according to field data, has an indicated E-W transgression (basin fill) orientation. Abbreviations used: LST = 2nd order lowstand systems tract; TST = 2nd order transgressive systems tract; HST = 2nd order highstand systems tract; FSST = 2nd order falling stage systems tract. Modified after Catuneanu and Eriksson (1999); in Eriksson et al., 2005. 127

Figure 4.9: Adapted from Eriksson et al., 2004. Time chart showing a framework of Earth evolution within which Precambrian sedimentation systems developed. Three superevents (event-clusters) are postulated at c. 2.7 Ga, 2.2–1.8 Ga, and at 0.8–0.6 Ga, when significant changes occurred within evolution of Earth’s natural systems (Eriksson et al., 2004). 136

Figure 4.10: Mat-related features in sandstones according to Schieber et al., 2007. An inferred palaeoenvironment set is suggested for every feature. The yellow rows are the common mat-related features found in the Daspoort Formation. 137

- Figure 4.11:** Average boron contents for the Pretoria Group formations. The Daspoort sandstones and shales are marked by blue and orange respectively. Standard deviation to the left of the lithology bar = (-1) and to the right = (+1). Modified after Schreiber (1992). 140
- Figure 4.12:** Pretoria Group Boron values versus stratigraphic height. Daspoort Formation sandstones and shales are in blue and orange respectively. Note that the values in brackets indicate extreme values which didn't fit the scale of the figure. Modified after Schreiber (1992). 141
- Figure 4.13:** New data and literature data provide isopach thickness plot of the Daspoort Formation. Note the basin's gradual eastern thickness changes compared to the much steeper alterations in the western part. The author's contribution is reflected by outcrop data. 143
- Figure 4.14:** Daspoort Formation basin palaeo-topography measured from field outcrops. Major flow directions are predominantly from the WNW and ESE. Black arrows indicate major regional flow patterns whereas white arrows indicate localised flow directions. Modern day topography, architectural elements seen in outcrops, wave ripple data interpretation along with dip and strike measurements were instrumental for the construction of this figure. Arrows from the northern part of the basin was interpreted from Eriksson et al., (1993) palaeo environment visualisation. 145
- Figure 4.15:** Ripple mark distribution across the Daspoort basin. 146
- Figure 4.16:** Palaeogeographic plot based on grain size and ripple mark spacing. The grey shading indicates the suggested area applicable to Daspoort palaeogeography using Tanner's equations and methods described above. Modified after Tanner (1971). 148
- CHAPTER 7**
- Figure 7.1:** Sketch map showing preservation of the Transvaal Supergroup within three structural basins on the Kaapvaal craton, southern Africa: Transvaal itself and Griqualand West basins, South Africa, and the Kanye basin, Botswana. The study area of Parizot et al., (2005) is indicated within the southern-central part of the Transvaal basin. Modified after Parizot et al., (2005). The indicated study area is marked by Parizot et al., (2005) and not applicable to this dissertation. 170
- Figure 7.2:** The Pretoria Group displayed by means of vertical exaggeration at an oblique angle using SPOT imagery. Courtesy of UP Geography department. 171
- Figure 7.3:** Legend of field outcrops. Note the horizontal grain size bar. 172
- Figure 7.4:** Swavelpoort outcrop, east of Pretoria. 173
- 14

Figure 7.5: East of Gopane outcrop, near Botswana border.	174
Figure 7.6: Faerie Glen outcrop, Pretoria East. Note the dominant upward coarsening trend.	175
Figure 7.7: Hekpoort outcrop, west of Gauteng.	176
Figure 7.8: Hoëbome outcrop, west of Rustenburg, North west Province.	177
Figure 7.9: Kaalbooi outcrop, near eastern Drakensberg escarpment.	178
Figure 7.10: Koster outcrop, north of Koster.	179
Figure 7.11: Sterkspruit outcrop, south of Lydenburg.	180
Figure 7.12: Mothlabeng outcrop, near Botswana border.	181
Figure 7.13: Nkwe outcrop, east of Pretoria.	182
Figure 7.14: Paul Kruger Street outcrop, near Pretoria CBD.	183
Figure 7.15: Saartjiesnek outcrop, west of Pretoria.	184
Figure 7.16: Scheerpoort outcrop, west of Pretoria.	185
Figure 7.17: Suikerboschfontein, north east of Carolina.	186
Figure 7.18: Soutpansberg Road outcrop, Pretoria.	187
Figure 7.19: Transport directions from herringbone cross-bedding, channel fills and ripple marks in the Daspoort Formation, east of Pretoria (Van der Neut, 1990). n = the amount of measurements. VS _i = Silverton Formation, Vd _q = Daspoort Formation, Vm = Magaliesberg Formation, Vmd = Dwaalheuwel Formation.	189
Figure 7.20: Sediment transport directions measured from planar trough cross-bedding in the Daspoort Formation, east of Pretoria. VS _i = Silverton Formation, Vd _q = Daspoort Formation, Vm = Magaliesberg Formation, Vmd = Dwaalheuwel Formation. Image from Van der Neut (1990).	190

Figure 7.21: Ripple mark data as calculated by Van der Neut (1990).	191
Figure 7.22: XRD Analyses - Dark microbial mat	192
Figure 7.23: XRD Analyses - Mud layer.	193
Figure 7.24: XRD Analyses - Whole rock	194
Figure 7.25: Isopach map of the Daspoort Formation. This was produced by Eriksson (1993) with supplementary data from Key (1983), Engelbrecht et al., (1986) and Hartzler (1989).	195
Figure 7.26: Turbidite succession (left) compared to the Bouma sequence (right). Modified after Bouma (1982).	197

LIST OF TABLES

Table 1: Stratigraphy of the Transvaal Supergroup in the Transvaal basin (modified after Button, 1986 and Schreiber, 1991).	23
Table 2: The measured thicknesses (in meters) of Daspoort outcrops across the basin.	31
Table 3: Average ripple mark parameters measured across the Daspoort basin.	55
Table 4: Various fetch results using the same input values, only different estimation formulae.	55
Table 5: Normalised values of element abundance of the coarse Daspoort sandstones. The right hand column indicates weight percentage of elements should SiO ₂ be omitted from the composition.	63
Table 6: A summary of the lithofacies associations in the Daspoort Formation describing their physical properties. The main facies assemblages are in capital letters with their sub-facies assemblages in normal text. Cross-bedded sandstone is divided into its two sub-facies, i.e. trough and planar cross-bedded sandstone.	105
Table 7: System tracts possibly associated with the Daspoort Formation in the Pretoria Group. Modified after Hunter and Tucker (1992); Catuneanu (2001); in Schieber, 2004).	128
Table 8: A display of average values for calculations from ripple mark data. Due to the variability of <i>fetch</i> values, using equations 17, 18, 18b and 19 from the previous chapter, it was not taken in consideration when discussing provenance and depositional setting. The dominant ripple type is marked in bold in the bottom row.	147
Table 9: A general petrological summary of the sandstones of the Daspoort Formation, if divided into 3 areas.	149
Table 10: A chronological representation of the various models for the Pretoria Group rocks as suggested by previous workers.	152
Table 11: Ripple mark morphology. The dominant/average dip direction and angles are shown. Asymmetrical ripple marks are included although their interference pattern does deviate from the major strike direction.	188

Table 12: Facies typical of fans and braidplain deposits (Miall, 1977; as modified by Miall, 1978 and Rust, 1978). 196

CHAPTER 1: INTRODUCTION

1.1 Aims

The purpose of this thesis is to investigate the physical characteristics of the Daspoort Formation, based on a set of field localities across an approximately east-west transect across the preserved Pretoria Group basin. These characteristics include outcrop scale lithological and stratigraphic data as well as thin section studies, ripple mark characteristics, palaeocurrent trends, and possible microbial mat features. These studies were supported, where necessary by XRD studies of relevant samples. All of these data are to be used together to infer the depositional conditions under which Daspoort Formation sandstones accumulated and some of the controlling geodynamic factors involved. The overall genetic model will be compared to existing literature on this formation.

1.2 Location of study area

The Daspoort Formation forms part of the Pretoria Group, Transvaal Supergroup which covers a large area in the northern parts of South Africa. This formation stretches from just across the Botswana border in the west through the Pretoria area in the central region of the preserved Pretoria Group basin, towards Carolina in the E-SE, and curves to the northeast in the direction of Lydenburg and further north thereof. Isolated outcrops are found near Groblersdal in the east and Balmoral in the southeast. The Daspoort Formation is also observed in the north near Mokopane (Potgietersrus) and in scattered outcrops towards the north western parts of the basin, south and southwest of Thabazimbi (Figure 1.1).

1.3 Geological setting/General geology

The Archaean Kaapvaal Craton hosts three structural basins which form part of the late Archaean to early Proterozoic Transvaal Supergroup. They are: The large Transvaal and Griqualand West basins in South Africa and the smaller Kanye basin in Botswana (Eriksson et al., 2001) (Figure 7.1 in Appendices).

The Daspoort Formation forms part of the upper Pretoria Group rocks of the Transvaal Supergroup (Figure 7.2 in Appendices). It overlies the Strubenkop shale unconformably (Eriksson et al., 1993b) and has a sharp contact with the overlying silt- and mudstones of the Silverton Formation.

The Neoarchaeon-Palaeoproterozoic eon is synonymous with large scale tectonic, magmatic, crustal, eustatic, denudation and depositional controls which resulted in distinctive volcano-sedimentary successions preserved worldwide of which the Transvaal basin is a remarkable example (e.g. Eriksson et al., 1999; Nelson et al., 1999).

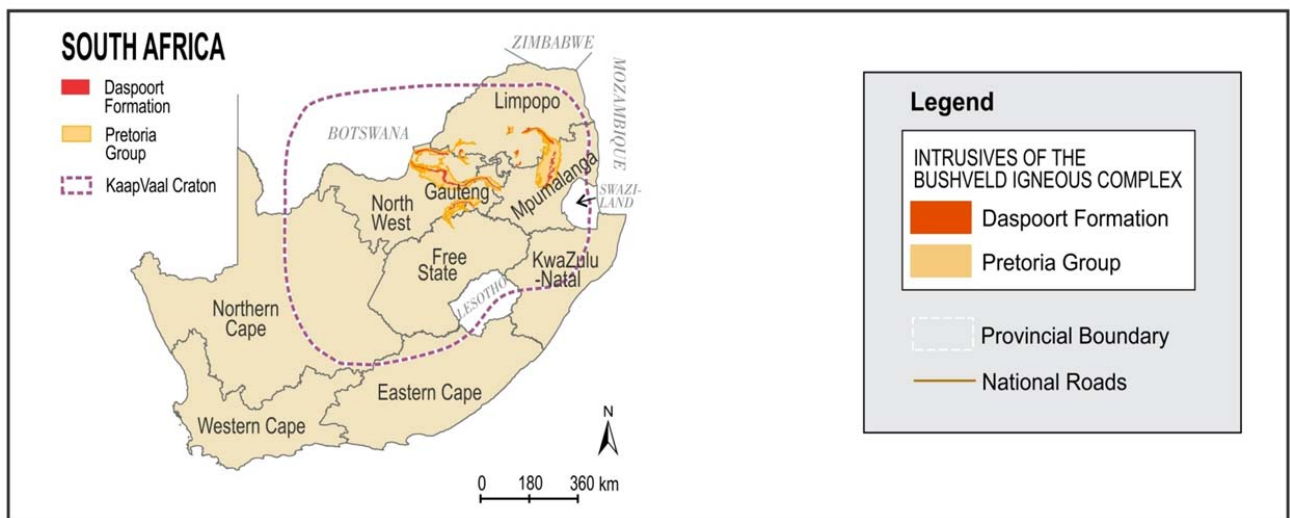
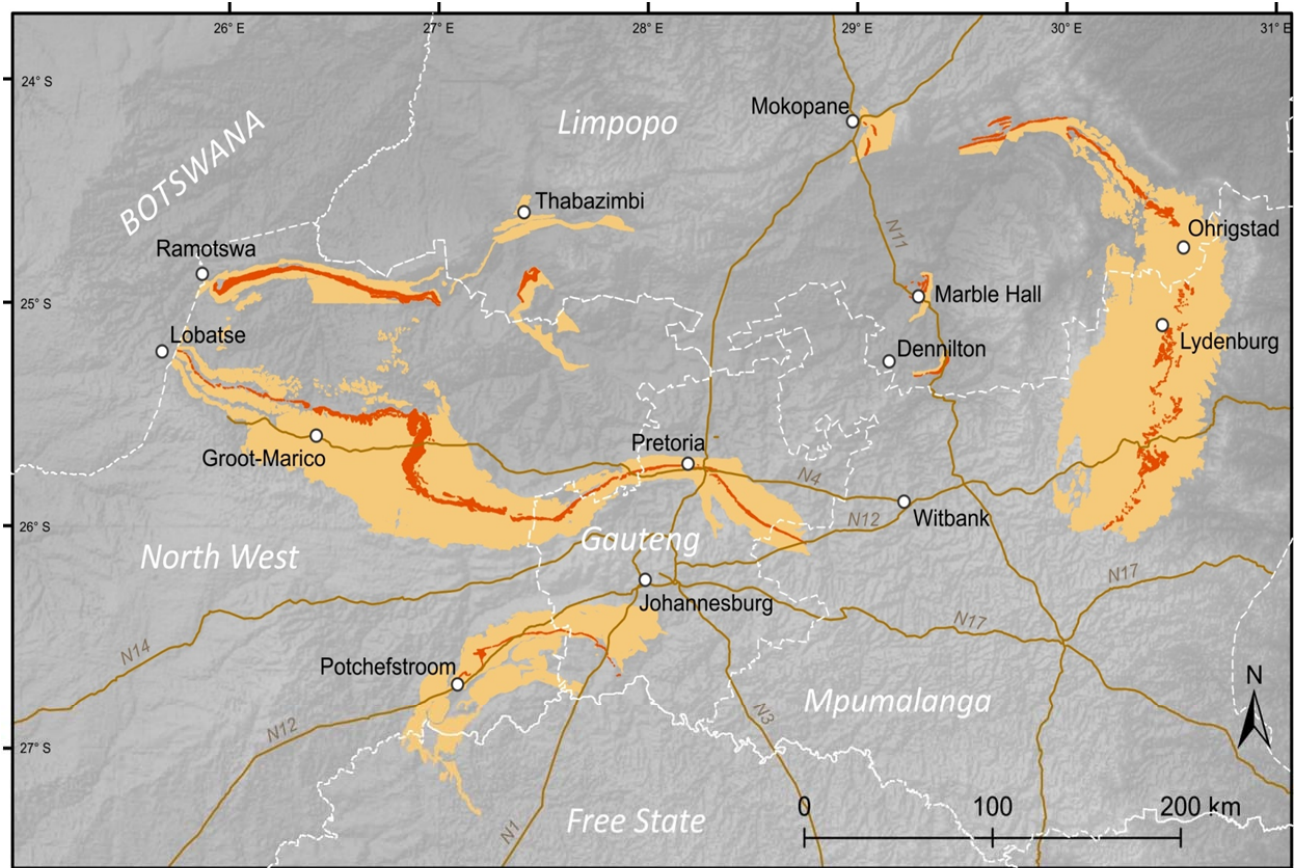

Figure 1.1: The occurrence of the Daspoort Formation in South Africa. Insert: The total extent of the Pretoria Group of the Transvaal Supergroup on the Kaapvaal craton is indicated in green. Modified after Parizot et al., 2005.

The earliest large carbonate platforms and some of the earliest Superior-type banded iron formations (BIF) (Altermann and Nelson, 1998) as well as significant clastic sedimentary and volcanic rocks occur within these successions, including the Transvaal basin-fills (Eriksson et al., 2001). The Transvaal Basin contains one of the thickest (c.15 km; Button, 1986) and most complete successions of these Neoproterozoic-Palaeoproterozoic rocks, and forms the floor rocks to the c. 2.05 Ga Bushveld Complex intrusion (Eriksson and Reczko, 1995). Due to the Bushveld intrusion the Transvaal Supergroup has undergone contact metamorphism, producing hornfelses and quartzites from clastic protoliths and asbestos deposits from BIF (e.g., Eriksson et al., 1998). This sedimentary (-volcanic) succession was deformed by pre-Bushveld open interference folds (e.g., Eriksson et al., 1998), faulting (e.g., Van der Merwe et al., 1988; Bumby et al., 1998), syn-Bushveld dykes and sills, and preserved Transvaal bedding mostly dips in towards the centrally located Bushveld Complex (Eriksson et al., 1995a). The Transvaal basin thus outcrops around the outskirts of the intrusion with isolated “fragments of Transvaal” floor rocks surrounded by Bushveld intrusives within the centre of the complex (e.g., Hartzler, 1995; Fig. 1).

The Transvaal basin has a maximum preserved basin-fill thickness in the east where it forms a prominent escarpment. Up to 14 formations in the Pretoria Group can be observed here (e.g. Schreiber, 1991) (Figure 1.2) and Table 1 for the major lithological description of these formations. The Pretoria Group is approximately 6-7 km thick in this region and generally comprises predominant mudrocks alternating with quartzitic sandstones, significant interbedded basaltic-andesitic lavas, and subordinate conglomerates, diamictites and carbonate rocks occur around the basin, all which have been subjected to low-grade metamorphism (Eriksson et al., 2001).

The Pretoria Group in the Transvaal basin is correlated with the Segwagwa Group in the Kanye basin in Botswana, and the latter sedimentary rocks have been dated for detrital zircons by SHRIMP U-Pb dating methods carried out by the Geology Department, University of Botswana. Zircon dating methods revealed ages ranging from 2193 ± 20 Ma (oldest) and 2055 ± 5 Ma (youngest) for the Pretoria Group. The latter age is related to the Bushveld Complex intrusion which overlies the Pretoria Group in some of the studied areas unconformably. The Daspoort Formation is compared with the Mogapinyana Formation in the Segwagwa Group by Mapoe et al. (2006). The youngest detrital zircon age acquired from the Mogapinyana quartzitic sandstones is 2236 ± 13 Ma (Mapoe et al., 2006).

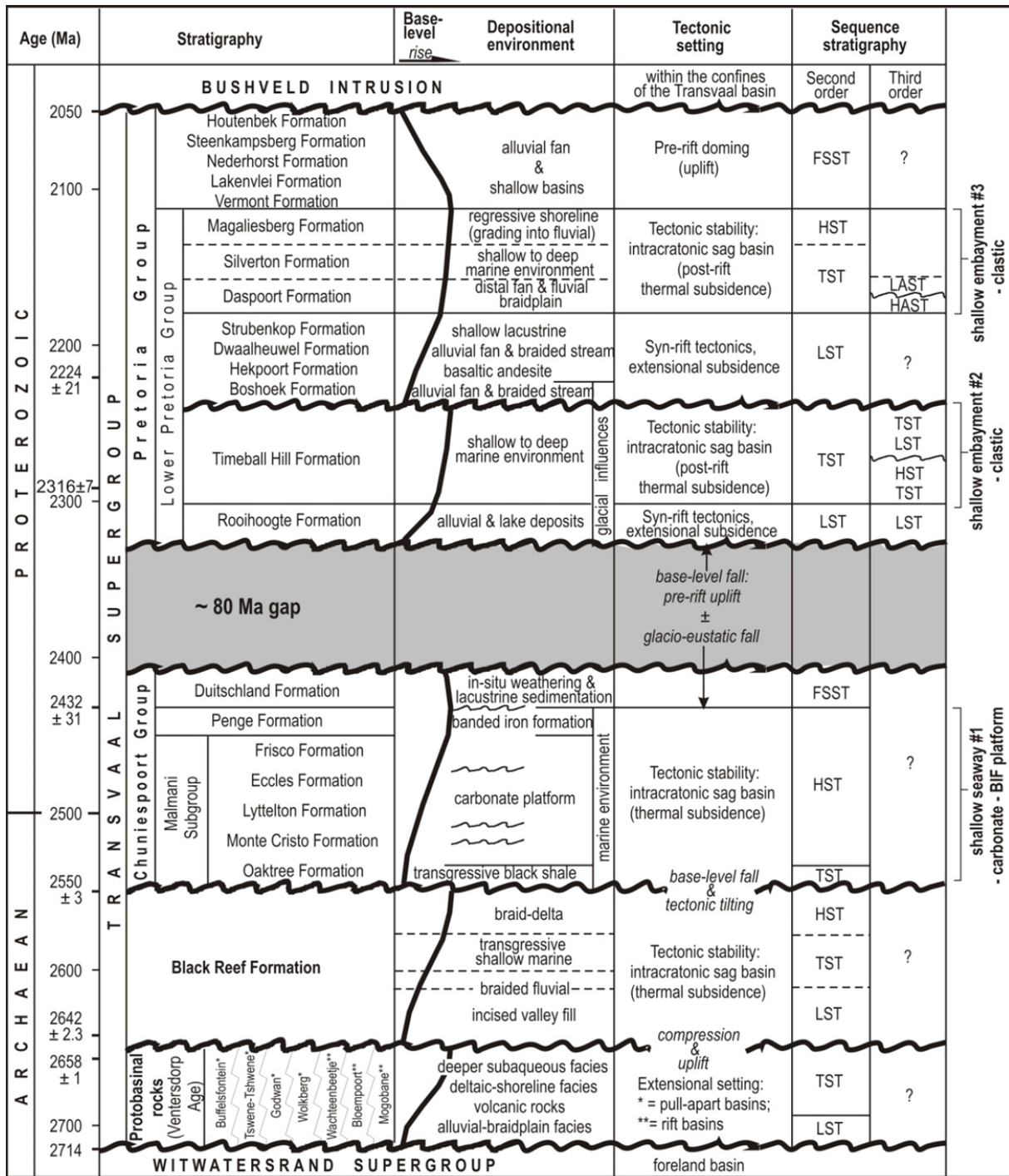

Figure 1.2: Summary of stratigraphy, geochronology, inferred base level changes, depositional palaeoenvironments and tectonic settings for the Transvaal Supergroup in the Transvaal basin (modified after Catuneanu and Eriksson, 1999; Eriksson et al., 2001; in Eriksson et al., 2005).

Table 1: Stratigraphy of the Transvaal Supergroup in the Transvaal basin (modified after Button, 1986 and Schreiber, 1991).

Sequence	Group	Formation	Major Lithology		
	Rooiberg		Felsite, Pyroclastic rocks		
Transvaal	Pretoria	Dullstroom	Basaltic and felsic lava		
		Houtenbek	Mudrock, quartzitic sandstone		
		Steenkampsberg	Quartzitic sandstone		
		Nederhorst	Mudrock, arkose		
		Lakenvlei	Quartzitic and arkosic sandstone		
		Vermont	Mudrock		
		Magaliesberg	Quartzitic sandstone		
		Silverton	Mudrock, lava		
		Daspoort	Quartzitic sandstone		
		Strubenkop	Mudrock		
		Dwaalheuwel	Quartzitic and lithic sandstone		
		Hekpoort	Basaltic andesite		
		Boshoek	Quartzitic sandstone, mudrock, conglomerate		
		Timeball Hill	Mudrock, quartzitic sandstone		
		Rooihoogte	Conglomerate, breccia, quartzitic sandstone		
		Chuniespoort	Duitschland	Dolomite, mudrock, diamictite	
			Penge	Iron formation, mudrock	
			Malmani (subgroup)	Malmani (subgroup)	Dolomite, chert
				Black Reef	Quartzitic sandstone
	Wolkberg		Mudrock, quartzitic sandstone, basalt, conglomerate		

The Pretoria Group sedimentation is thought to be the result of two cycles of rifting and subsequent thermal subsidence, which accommodated the advance of a shallow epeiric sea onto the Kaapvaal craton twice (Catuneanu and Eriksson, 1999; Parizot et al., 2005). Plate tectonically induced rifting during a global episode of lowered sea levels (Figure 1.3) concomitant with the first major global glaciation at c. 2.4-2.2 Ga, marked the first cycle; during this time the Timeball Hill epeiric sea originated (Catuneanu and Eriksson, 1999; Fig.4).

The second cycle is related to a cratonic-scale continental flood basalt event at c. 2.2 Ga (the Hekpoort–Ongeluk flood basalt) which is preserved in all three Transvaal basins; subsequent to this a larger epeiric sea formed within the area of the Transvaal and Kanye basins (see Appendices), where the Daspoort-Silverton-Magaliesberg sedimentary package was laid down (Parizot et al., 2005). Hubert (1962) states that the degree and type of tectonism determine the preferred associations of source area lithology and relief, rate of subsidence of the depositional basin, and systems of sedimentation and specific loci of deposition. The Daspoort Formation is no exception. According to Eriksson et al.; (1993), Daspoort sedimentation began with alluvial gravel and fluvial sand lobes of syn-rift affinity, which became drowned in the east of the basin by a transgressive marine palaeoenvironment. The Daspoort Formation is characterised by eastern shallow marine sandstones which were formed coeval with western fluvial deposits (Eriksson *et al.*, 1993; Eriksson and Catuneanu, 2004).

The Daspoort Formation is characterised by commonly massive, clean, mature sandstones. Predominant recrystallised fine- to medium grained sandstones with lesser conglomerates, coarse-grained sandstones and some minor mudrocks and ironstones occur (Eriksson et al., 1993). Diagenesis and low grade metamorphism (due to Bushveld intrusion) of the Pretoria sedimentary rocks resulted in recrystallisation of the Daspoort sandstones in many areas, producing quartzites (Eriksson et al., 1993).

The Dwaalheuwel and Strubenkop Formations, which separate the Daspoort Formation from the Hekpoort lavas, are absent in the Kanye basin of Botswana (Key, 1983) due to possible uplift and erosion prior to Daspoort sedimentation (Eriksson et al., 1993). The actual lower Daspoort contact in the Transvaal basin is erosive although the underlying Strubenkop Formation is coarsening upward (Eriksson et al., 1993). Button (1973) describes this contact to be gradational in the eastern parts of the Transvaal basin.

This same contact is described as erosive by Schreiber (1991) who studied the Pretoria Group in the same eastern part of the basin, where she found mainly quartz arenites in the Daspoort. The Daspoort-Silverton contact is generally sharp (Eriksson et al., 1993).

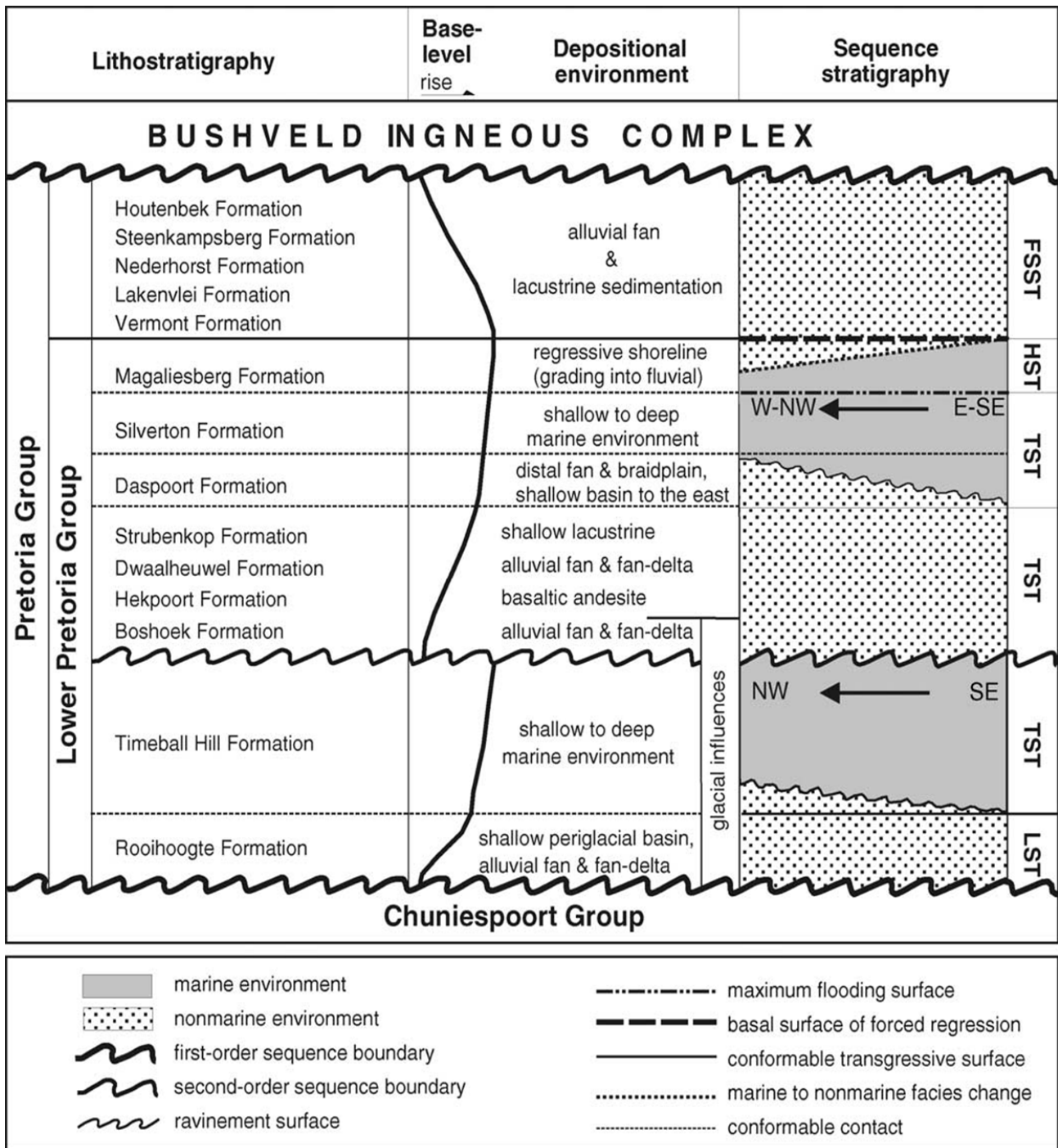

Figure 1.3: Sequence stratigraphic model for the Pretoria Group; note that this figure is not drawn to scale, but that the vertical axis suggests both time and thickness. Arrows in the column headed "sequence stratigraphy" indicate directions of shoreline transgression. Abbreviations used: LST = 2nd order lowstand systems tract; TST = 2nd order transgressive systems tract; HST = 2nd order highstand systems tract; FSST = 2nd order falling stage systems tract. Modified after Catuneanu and Eriksson (1999); in Eriksson et al., 2005.

1.4 Methods

This project is based on previous research as well as extensive fieldwork throughout the preserved East-West-extent of the Pretoria Group.

Methods used to study the Daspoort sandstones included sampling where possible, XRD analysis, thin section studies and drawing vertical sections through the formation at the various field sites and then comparing them with one another.

Whenever possible, sampling concentrated on unaltered or fresh medium- to coarse-grained sandstones. Sampling was done at Daspoort Formation outcrops across the basin, bar the northern parts. Commercial farming (game, fresh produce), private property, inaccessible terrain and unsafe conditions contributed to limit meaningful sampling in the modern South African environment.

Grain size measurements were acquired from the thin sections. These were also handy to describe sorting, weathering, mineral identification and sandstone maturity. All the ripple marks were measured to comply with Tanner's (1967; 1971) formulae for estimating ripple type (wind, wave, current or swash ripples), wave height, fetch and water depth. The nomenclature, the formulas used and their applications are explained in detail in the Lithofacies chapter. Palaeocurrent data were recorded also, mainly from trough cross-bedding and channel-fill flow directions to create a set of palaeoenvironmental data together with the ripple information. The strike, dip and dip direction of the above-mentioned were acquired in the field by means of a Breithaupt compass.

Weathering and low grade metamorphism is prominent in the Pretoria Group sandstones, thus fresh samples were difficult to collect. Any possible microbial mat features observed were carefully examined and recorded.

Geochemistry did not require extensive attention due to the fact that Reczko (1994) and Van der Neut (1990) covered this adequately. Basic XRD analyses were done on the sandstones and quartzites to aid lithological identification and classification.

Facies assemblages were constructed according to grain size, composition, degree of mineralization (maturity), sedimentary structures and sedimentary architecture. Some facies matched previous authors' descriptions, but a detailed description accompanied by palaeocurrent and structural data are supplied with substantial field evidence. The facies assemblages are laterally correlative, and are assumed to have been associated with events, both localized and regional.

Basin geometry is illustrated by means of GIS modelling using borehole and topographical information topped with geology. Palaeoenvironmental data also supported transport and geometrical evaluation of the Pretoria basin.

1.5 Previous work

No extensive geological research has been carried out on the Daspoort Formation except for Eriksson et al. (1993) who developed an alluvial-marine model and who provided an isopach map, inferred palaeocurrent directions and lithofacies relationships across the basin, within an overall large scale study. The present study was intended to provide more detailed information in order to build upon this earlier work, itself based partly on pre-existing literature. Button's (1973) valuable study of Daspoort sedimentation is restricted to the eastern part of the Transvaal basin, as is that of Schreiber (1991).

Visser (1969) described the Daspoort Formation in the Pretoria region as reflecting a modified fluvial – beach depositional environment. He suggested that the Daspoort Formation supports two large fluvial systems entering the Transvaal basin from the north, with marine wave reworking in the southern parts of the basin. Button (1973) had a similar interpretation of the massive Daspoort sandstones in the east and northeast of the Transvaal basin, where he argues for an overall beach environment or even a shallow marine shelf.

Schreiber (1991) compared the Formations of the Pretoria Group and proposed a delta front deposit model for the Klapperkop sandstone member of the Timeball Hill Formation, the Daspoort Formation and the Steenkampsberg Formation. She also discusses the possibility of a deltaic palaeoenvironment in more detail for the Daspoort and interpreted the mature Daspoort sandstones in the southeast of the study area to be distributary mouth bar deposits.

Some of the Daspoort arenites are believed to represent fan-toe braidplain deposits in the east of the study area (e.g., Schreiber, 1991). For the Pretoria Group as a whole (in the Transvaal-Kanye basins), earlier workers suggested an alluvial-lacustrine palaeo-environment (e.g., Crockett, 1972; Eriksson, 1986, 1988; Eriksson and Clendenin, 1990) with uppermost shrinking-basin, fluvio-deltaic lake-fill sedimentation terminating deposition in the eastern part of the Transvaal basin. The two rift-cycle, overall epeiric marine-intervening fluvial depositional model espoused by Eriksson et al. (2001, 2006; see also Catuneanu and Eriksson, 1999) is perhaps better constrained than this earlier work. P.G. Eriksson has extensively studied the Transvaal basin throughout the 1990's and 2000's.

Together with numerous other researchers, Eriksson and co-workers have concluded that the Daspoort Formation was essentially a distal fan, fluvial braidplain environment passing eastwards into a shallow marine basin where the tectonic setting reflected an intracratonic sag basin which formed after thermal and preceding rift-type subsidence (e.g., Eriksson and Catuneanu, 2004).

1.6 Previous work: Lithofacies identified by previous workers

Below follows a brief description of the lithofacies identified and described by previous authors.

1.6.1 Pebbly sandstone

According to Van der Neut (1990) these pebbly facies are usually found in horizontal layered units which have a poorly sorted arkosic to a well sorted sublithic arenitic nature. One hundred metres of recrystallised arkosic quartzite is preserved at Mokopane (Potgietersrus) whereas the Pretoria region has much better preserved outcrops (Eriksson et al., 1993). Between 40 m and 60 m of medium- to coarse-grained well sorted arkoses are found here with subordinate lithic arenites (Eriksson et al., 1993). Finely laminated pebbly arkoses are observed near the Strubenkop contact. These are also chert-bearing (Eriksson et al., 1993). Planar bedding is common in this facies with thicknesses between 1 cm and 25 cm and some ranging up to 60 cm (Eriksson et al., 1993). Smaller-pebble conglomerates are more prominent in the basin west of Pretoria. These are also prominent in Botswana; they have about 10-50% pebbles, consisting of quartz, chert, jasper and mudrock, set in a sandy matrix (Key, 1983). Planar cross-bedding is poorly preserved in these rocks (Key, 1983).

1.6.2 Fe-rich sandstone

These rocks are common in the northeastern part of the Pretoria basin, where they show a close resemblance with the mudrock facies (Button, 1973). These rocks are mainly ferruginous quartzites and quartzitic ironstones (Eriksson et al., 1993). These sandstones are characterised by patchy development of ferruginous stains by their iron-rich matrix material (Button, 1973).

1.6.3 Mudrock

Interlayered laminae of mudstone, siltstone and very fine-grained sandstone characterise the mudrock facies of the Daspoort Formation (Eriksson et al., 1993). Thick mudrocks (40 m) are common in the east of Botswana and while a thinner sequence (15 m) occurs at Potgietersrus; the latter is found interbedded with parts of the sandstone and Fe-rich sandstone facies (Eriksson et al., 1993). These finely laminated interbeds are ferruginous in the northeastern portion of the basin and have a variable thickness from a few centimetres up to a couple of meters in the eastern part of the basin (Eriksson et al., 1993). These facies display horizontal lamination and isolated cases of planar cross-lamination is noted (Button, 1973). Thicker mudrock successions are found in the Lydenburg area (Schreiber, 1991) and become more prominent northwards from there.

1.6.4 Cross-bedded sandstone

Planar cross-bedded, medium- to coarse-grained sandstones characterise this facies (Van der Neut, 1990). Locally, there are channel-fills that have sharp erosive contacts with the cross-bedding which is often cut off by the base of the channel-fill (Van der Neut, 1990).

1.6.5 Horizontally laminated sandstone

This dominant facies in the Daspoort Formation is compositionally mature and is characterised by quartz arenites which are interbedded with quartz wackes and sublithic arenites (Schreiber, 1991). The quartz arenites are reasonably well sorted with quartz showing some overgrowths, but the less mature sandstones have quartz grains embedded in a bimodal fine-, to a more rarely, very fine-grained matrix (Schreiber, 1991). The dark colouring, due to Fe-oxide enrichment, is found sporadically as lenses or stains and is not limited to a single unit (Van der Neut, 1990). Eriksson et al. (1993) have subdivided the planar bedded sandstones into a finer and a coarser subfacies. Quartz arenites, sublithic arenites and quartz wacke compositions characterise this facies which occurs throughout the basin (Eriksson et al., 1993). The finer subfacies have a fine- to medium-grained quartz arenite composition with well-rounded grains and good sorting to mark mature sandstones (Eriksson et al., 1993). Sand waves with wavelengths up to 50 cm and ladderback ripple marks are found in the upper parts of this facies (Eriksson et al., 1993). The coarser subfacies is defined by fine- to medium-grained quartz wackes with interbedded mudrocks and mudclast layers, but coarse- to very coarse-grained pebbly quartz arenites occur as well, mostly just west of Pretoria, at Marble Hall and Dennilton (Eriksson et al., 1993) and in the western part of the basin. The common structures in this facies include channel-fills (1 m - 12 m wide, 15 cm - 100 cm deep) and planar bedding between 4 cm and 1 m thick (Eriksson et al., 1993). This subfacies is best observed in eastern Botswana, the far North West and Thabazimbi areas and then amalgamates into the finer subfacies eastwards towards Pretoria (Eriksson et al., 1993).

CHAPTER 2: REGIONAL CHARACTERISTICS

2.1 Thickness trends and facies relationships

The succession can reach a thickness of up to 300 m in the west of the basin where the lithologies have a gentle to sub-horizontal dip. Thin outcrops are found at numerous localities such as at Pretoria in the south central part of the basin, along the eastern escarpment of the Transvaal Supergroup and at an isolated outcrop at Dennilton. The Daspoort sandstones show a thickness change of up to 90%. The thickest areas are around Koster in the west of the Pretoria Group basin. The escarpment presents big cliffs of Daspoort cross-bedded sandstones. Cross-bedding, especially planar, is associated with these thick successions of Daspoort arenite outcrops. Trough cross-beds are common in the central parts of the basin as well as channel-fills, which become more prominent towards the west where outcrop thickens. Lateral facies changes are less common, but are still noted especially in the east, where average grain size changes from north to south (fine in the north, coarser in the south). Schreiber (1991) suggested that the Daspoort Formation in the east represents clastic wedges rather than sheet sands. Moving towards the inferred basin-centre, relatively west of the eastern main outcrop, the mature arenites are followed vertically by moderately sorted sandstones and some mudrocks, and further 'basinwards', by ironstones and ferruginous sandstones (Schreiber, 1991). Interbedded mudrocks are found sporadically within the predominant sandstones throughout the basin. These mudrocks often grade into thicker adjacent sandstone units which expose the mudrocks' susceptibility to vertical facies changes. A strong upward coarsening nature of the Daspoort sandstones is prominent in the west of the basin, but this trend tends to become less apparent towards the east. Mature sandstones are also locally associated with prominent topographical features and are seen with minor amounts of mudrock in the southeast with the latter becoming more common towards the north of the preserved basin.

Van der Neut (1990) found that the pebbly sandstone facies is dominant in the basal units of the Daspoort Formation near the underlying Strubenkop Formation mudrocks. This was not concomitant with recent findings where this facies was found preferentially in the upper Daspoort succession, rather closer to the overlying Silverton Formation.

The thicknesses of the mapped Daspoort Formation outcrops recorded in the field are in most cases relatively inaccurate due to the fact that exposures often are located in inaccessible terrain, with talus and vegetation cover and on private and state owned land which, at times, are forbidden territory or unsafe. It is thought that measured outcrops have a higher true thickness than the measured (partial) field exposures.

The thickest units (± 100 m) were found near the eastern escarpment at Suikerboschfontein where the outcrops form cliffs (Figure 2.1). Similar thicknesses are exposed by road cuts west of Pretoria. Most of the remaining sites have measured outcrops thicknesses fluctuating between 20 m and 50 m (Table 2 and Figure 2.1).

Table 2: The measured thicknesses (in meters) of Daspoort outcrops across the basin

Location	Thickness (m)	Dip angle	True thickness (m)
Scheerpoort	114	35	126.15
Saartjiesnek	76	18	115.10
Paul Kruger	48	37	62.71
Nkwe	28	9	30.73
Soutpansberg	37	35	40.94
Suikerboschfontein	100	3	101.01
Faerie Glen	36	19	36.41
Hoëbome	6	2	14.42
Koster	15	8	103.09
Sterkspruit	48	3	48.49
Kaalbooi	42	2	100.93
Hekpoort	24	18	36.35
Mothlabeng	24	10	28.60
East of Gopane	28	7	37.14
Swavelpoort	24	10	28.60
Apiesrivier	80	28	83.11
Hans Strijdom	44	4	67.31
Oberon	34	20	83.32
Lindleypoort	30	6	31.24

An isopach (Daspoort Formation regional thickness) map has been compiled using previous authors' borehole information as well as new thickness observations from outcrop data across the Daspoort Formation (Figure 2.2). Corresponding thicknesses are linked via contour lines across the study area. Anomalies in the central basin area occur due to poor/no outcrop information. Interpretation of the map yields similar contour patterns in the northern, and to a lesser extent, the eastern basin areas. This is attributed to poor outcrop and limited accessibility. The area affected by the Vredefort impact crater remained unchanged as well. The Pretoria region thicknesses are predominantly concomitant with historical data. The western parts of the Daspoort basin have the steepest gradients, although the general dip of the Daspoort Formation in this area is very gentle to sub-horizontal. Thickness changes are rapid, especially taking into account the thick borehole successions compared to thin outcrops.

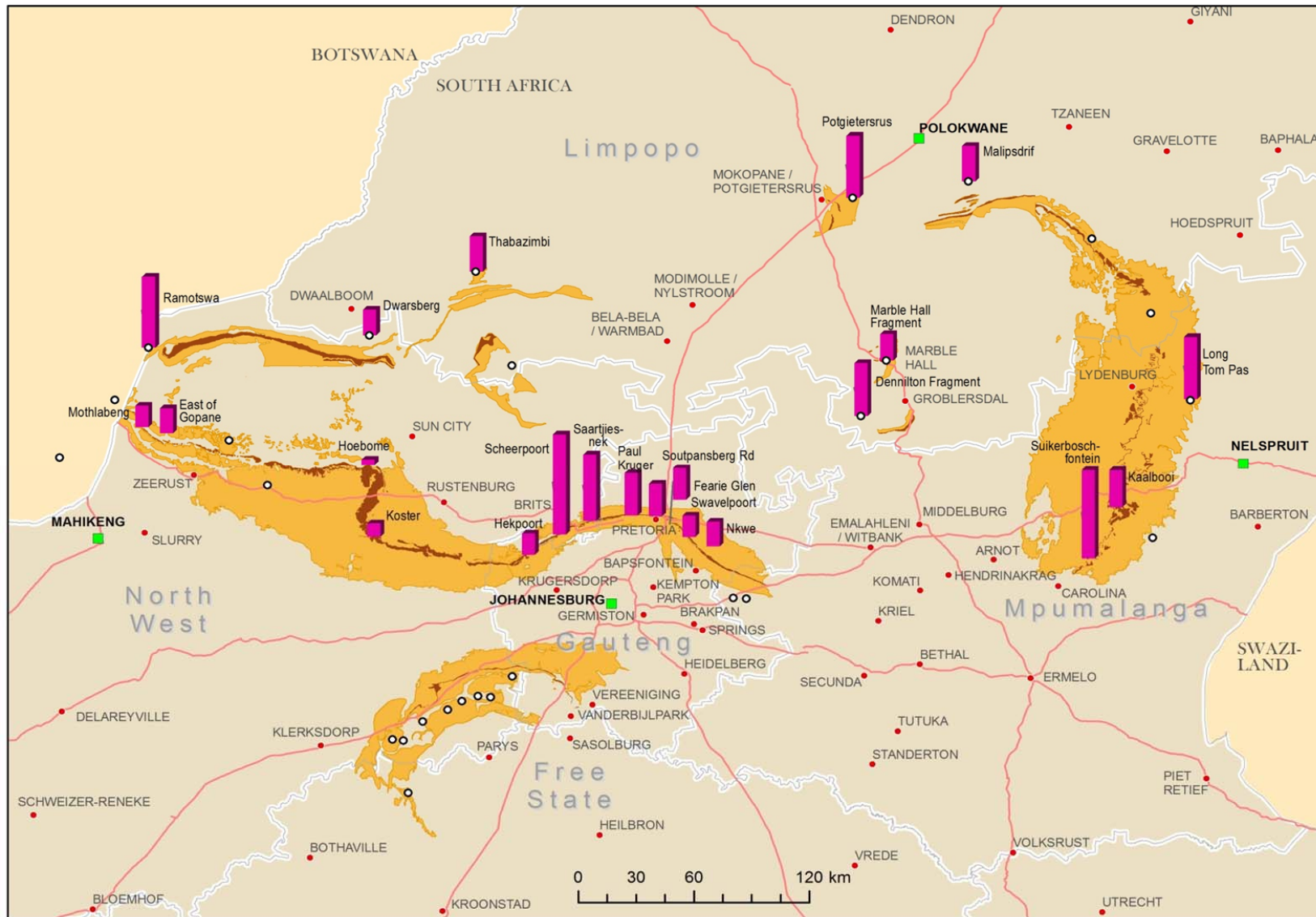

Figure 2.1: Relative thicknesses of the Daspoort Formation in outcrops and boreholes (marked by white circles) across the study area. True thicknesses are given by Table 2. Relative thicknesses from the Vredefort area are omitted as this area was not part of the author's field observations.

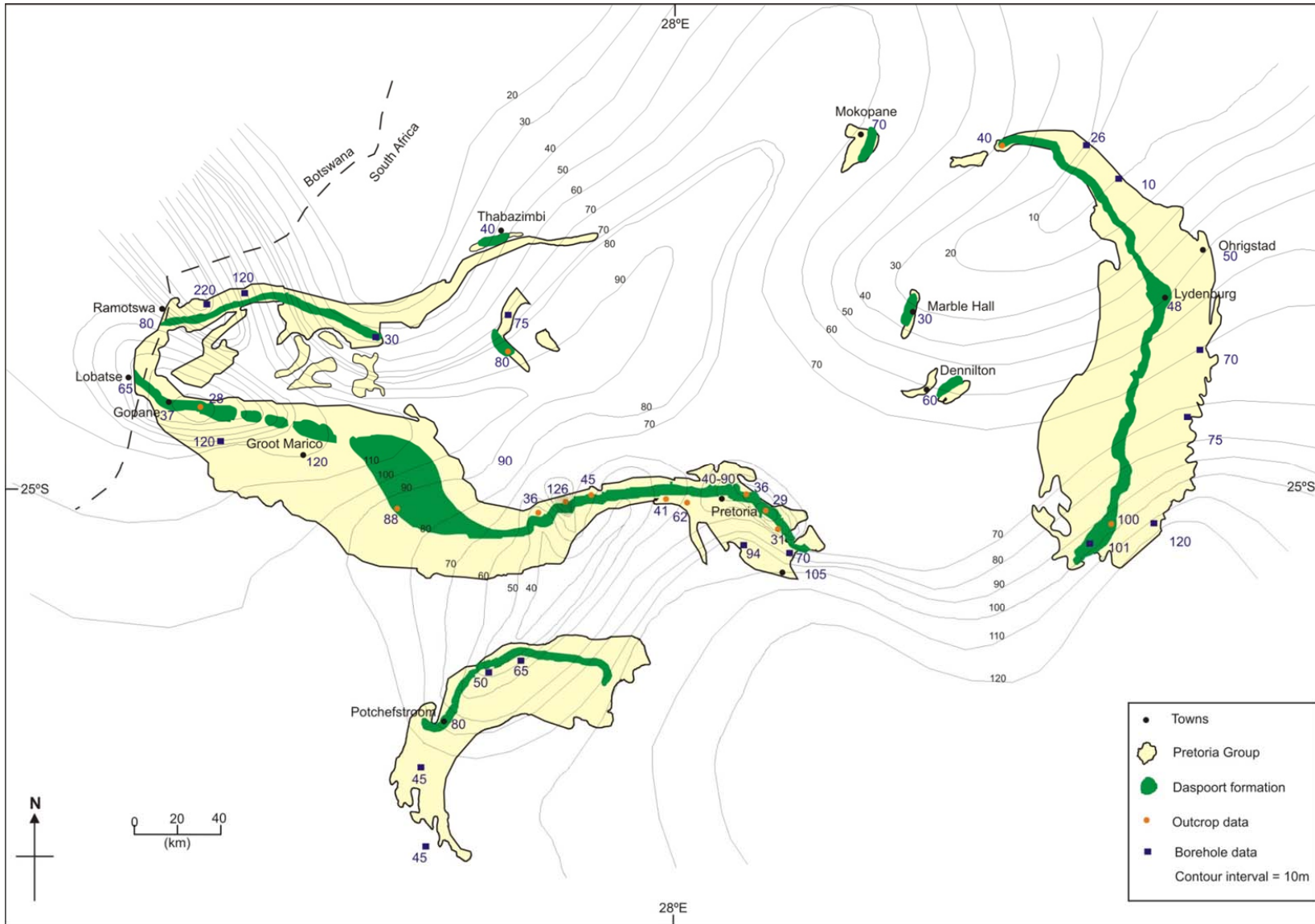

Figure 2.2: New data and literature data provide isopach thickness plot of the Daspoort Formation. Note the basin's gradual eastern thickness changes compared to the much steeper alterations in the western part. The author's contribution is reflected by outcrop data.

Regionally the Daspoort Formation shows an upward-coarsening trend, except for the far eastern basin where mudrocks, ironstones and massive sandstones are abundant. See Appendices chapter for a schematic illustration of these upward coarsening / upward fining trends. Structures such as channel-fills, erosion surfaces and load casts are found in the upper succession of the Daspoort Formation. Two distinctive units are observed within the Daspoort Formation; a thin upper unit consisting of coarse grained sandstones, mainly arkosic wackes and lithic arenites, and a lower thick unit. The lower unit can be classed as a recrystallised quartzite and to a lesser degree an arenite. This unit consists of seemingly more mature sandstones than those of the upper unit. Bedding is also more predictable in this unit. The two units are separated by an erosion contact which reflects evidence of scouring, load casts and other channel floor features. Considering only the texture and sedimentary structural properties of the two units, the upper unit is tentatively linked to an alluvial setting while the lower unit is related to a shallow marine environment.

Upward-coarsening trends are encountered throughout the upper unit, predominantly in the middle areas, of the Daspoort Formation. The lithologies associated with these trends are generally medium- to coarse-grained sandstones. These are usually associated with shallow marine or alluvial environments where high energy conditions prevailed. The channel-fills display similar calibre characteristics, except that other physical features such as scours, load casts and incised erosion contacts are encountered. This is prominent in the west and their varying palaeocurrent directions in the Pretoria region are significant contributors when discussing the possible genesis of these sandstone features. The biggest channel-fill observed in the field was up to 6 meters wide and half a meter at its deepest. Trough cross-bedding with very coarse grains being the diagnostic separator between the stacked sets, are prominent in the medium to large scale channel-fills.

Erosive contacts are common in the Daspoort Formation vertical profiles. They reflect stadia of high energy and erosion rather than hiatus conditions, inferred due to the steep palaeotopography at the time and the common occurrence of cross-bedded arenites near these contacts. The upward-coarsening nature of the Daspoort sandstones, particularly in the central and western parts of the Pretoria basin, is often superseded by an erosion surface, forming the channel base or asymmetrical wavy floor of a local fluvial gravity flow system. Both the units in the Daspoort Formation lack bounding subaerial nonconformities, therefore they are classified as system tracts instead of sequences (Eriksson et al., 2004, see Catuneanu (2002) for definitions).

It is difficult to correlate the borehole and outcrop profiles across the Pretoria Group. The thickness of individual units in the Daspoort Formation varies over the vast lateral extent of the preserved basin and the effect of erosion and regional metamorphism contributes to the lack of preserved sedimentary structures used for correlation techniques. Therefore it is suggested that so-called 'events' or energy pulses are interpreted to determine the lateral continuity of such 'events' that could clarify environmental and sedimentological conditions during that time. These packages are closely simulated

with the distribution of facies assemblages and they're bounded by erosive contacts or identified grain size trends.

The central Daspoort Formation in the Pretoria area is populated with thin units of various facies associations. These range from pebbly lithologies to quartzites. This area is dominated by cross-bedding of medium to coarse grain size while rare massive sandstone units are generally characterised by erosive bottom contacts. The latter units are thicker towards the east, with lesser 'contamination' of other facies assemblages. The unimodal massive sandstone units, usually bounded by prominent erosive top contacts, represent longer periodical 'events'. The profiles are much thicker here than elsewhere in the Daspoort Formation. The western part of the study area can be interpreted as an amalgamated analogue, equivalent to the above-mentioned locations. Here the units alternate between massive sandstones and bedded sandstones with less mudrocks than the central and eastern basin. The western units appear to be laterally more continuous, but coarser grained than elsewhere. Similar erosive patterns are encountered as described above.

Upward-coarsening sequences are prominent throughout the Daspoort Formation, especially in the west where the grading of coarse sandstones into pebbles is a good example. The pebbly units often are underlain by trough cross-bedding. Elsewhere higher-order upward-coarsening trends contain smaller and less frequent upward-fining cycles.

It is interesting to note that upward-fining sequences dominate the massive sandstones in the eastern Daspoort basin. They are separated by either erosion contacts or weathered mudrock facies. These upward-fining units are thick and don't involve mudrocks. Scouring and load casts are absent, but trough cross-lamination is observed locally. The central basin lacks upward fining sequences. The isolated units showing some sort of low energy conditions are unconformably cut off by erosion or bedding planes. Similar observations are made in the western basin.

In contrast to the lack of fine material, upward-coarsening units are abundant in the Daspoort Formation, especially in the central and western study areas. Similarly to other areas in the basin, the upward-coarsening units are eroded at their tops. Oxidised matrix minerals are often found on these surfaces. Upward-coarsening units are often seen immediately above finer cross-laminated sandstone or quartzite which, as a rule of thumb, occurs lower in the Daspoort Formation succession. Upward-coarsening units are much thinner in the central basin than anywhere else – bedding in this area is detailed and units are thinner which allows for variation in energy flux interpretations.

There is no distinctive bedding sequence which correlates laterally across the basin. The central Daspoort basin displays the biggest variety of bedding patterns. These are generally exposed in the thin quartzite and well sorted arenite units. Small scale herringbone cross-stratification, ripple cross-lamination and trough cross-bedding are associated in this inferred complex high energy depositional environment. These sedimentary elements are often alternated with horizontally laminated matured

sandstones, but are replaced higher up in the succession with larger coarse-grained cross laminated arenite and wacke packages/units. Bedding patterns in the west become more evident with the larger scale channel fills and coarser units. Convolute bedding and trough cross bedding exists within the coarse units. Massive sandstone units have poorly visible bedding patterns, but the odd occurrence of cross-bedding can be identified where minerals are oxidised (see Lithofacies section) to form dark lines along these patterns. There is also interplay between thin horizontal and thicker cross-laminated sandstone lithofacies. This interaction dissipates towards the eastern parts of the basin. Instead, the units grow bigger and more structureless; however large scale trough cross-lamination is observed in the Carolina area (SE of basin). The mudrocks in this part of the basin do display faint horizontal bedding, but the mudrocks are generally massive and structureless. Quartz wackes are abundant as well as arkosic arenites. These are the coarsest lithofacies in the eastern basin and generally forms the lower part of the Daspoort succession. The distribution of lithofacies in the Daspoort Formation contradicts the general Pretoria Group lithofacies distribution.

Erosion surfaces are common in the area, often displayed as massive asymmetrical rippled surfaces. Other structures such as load casts, grooves and loading structures are evident at the interfaces between the mudrocks and massive sandstone units.

Systems tracts are the three dimensional arrangements of environmental facies that go hand in hand with sequence stratigraphic stages such as regressive, lowstand, transgressive, highstand. These are described in the Discussion chapter. It should be remembered that system tracts are not ideally suited for Daspoort nomenclature due to the poor preservation potential of shorelines, base level and other interface elements on which system tracts are measured and explained. One should rather refer to accommodation space created (high stand system tracts or transgression) or lack of accommodation space (low stand system tract or regression). The lateral discontinuity of facies assemblages also contribute to a preferred energy and capacity related description. These sequences, termed 'events', are easily identified in the Daspoort succession and are useful for the reconstruction of depositional environments using lithofacies, especially in shallow marine, fluvial or lacustrine settings (Figure 2.3, Figure 2.4 and Figure 2.5). A legend for these images and more supplementary annotations are displayed in the Appendices (from Figure 7.3 to Figure 7.18). These three figures show the vertical succession of the Daspoort Formation for every studied part of the basin, i.e. western, central and eastern basin. From this a lithofacies model is envisaged to interpret the cyclical events and establish a depositional environment. Figure 2.6 displays an amalgamated picture of sandstone maturity using the vertical profiles and roughly, where possible, correlate events of similar lithologies. This also gives an idea of the depositional environment on a local scale

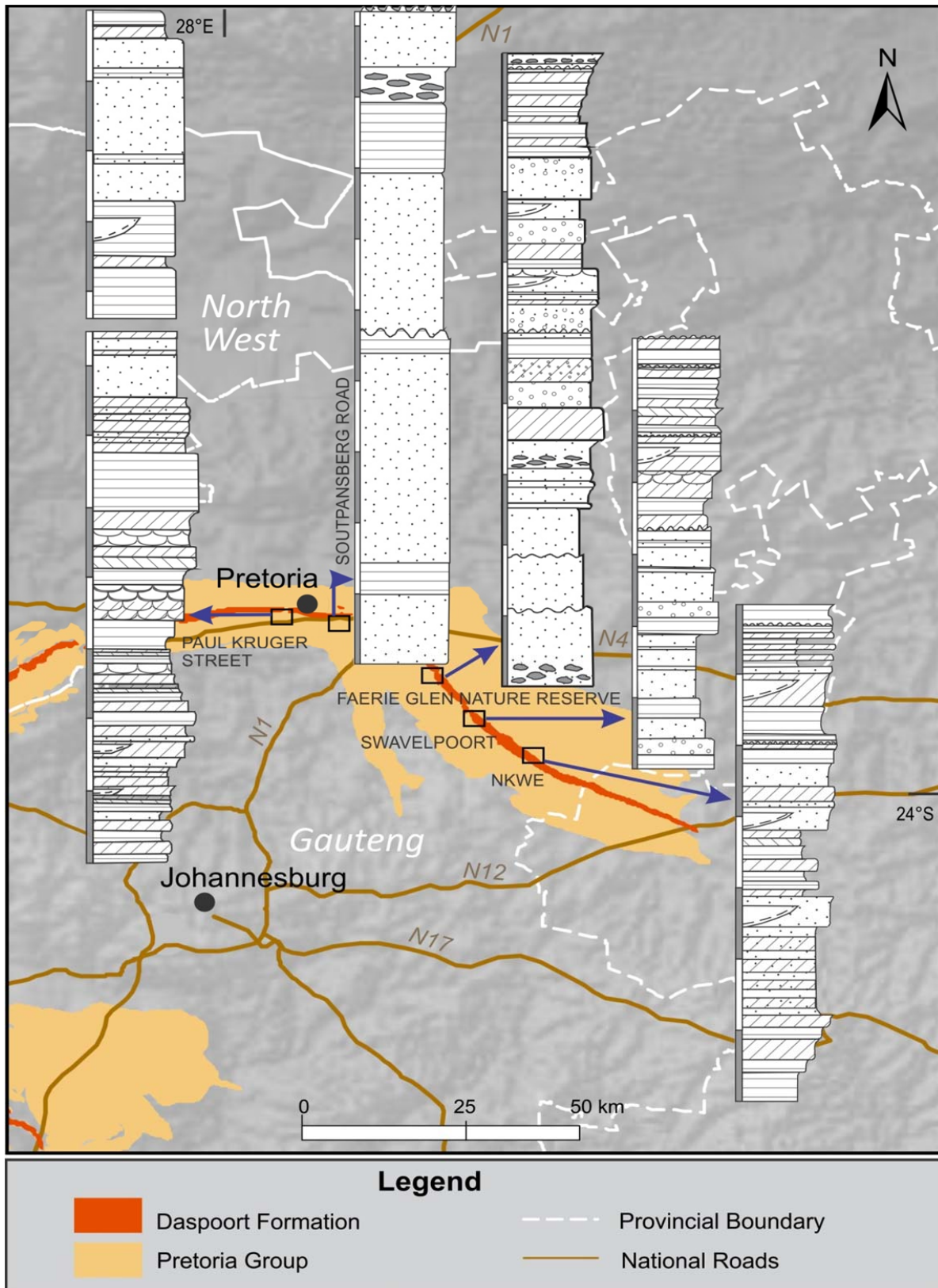

Figure 2.3: Vertical profiles generated from outcrops in the central Daspoort basin. The squares indicate outcrop localities (vertical profiles) of the Daspoort Formation. Each bar next to the vertical profile represents 4 m. i.e. the Nkwe succession is 28 m.

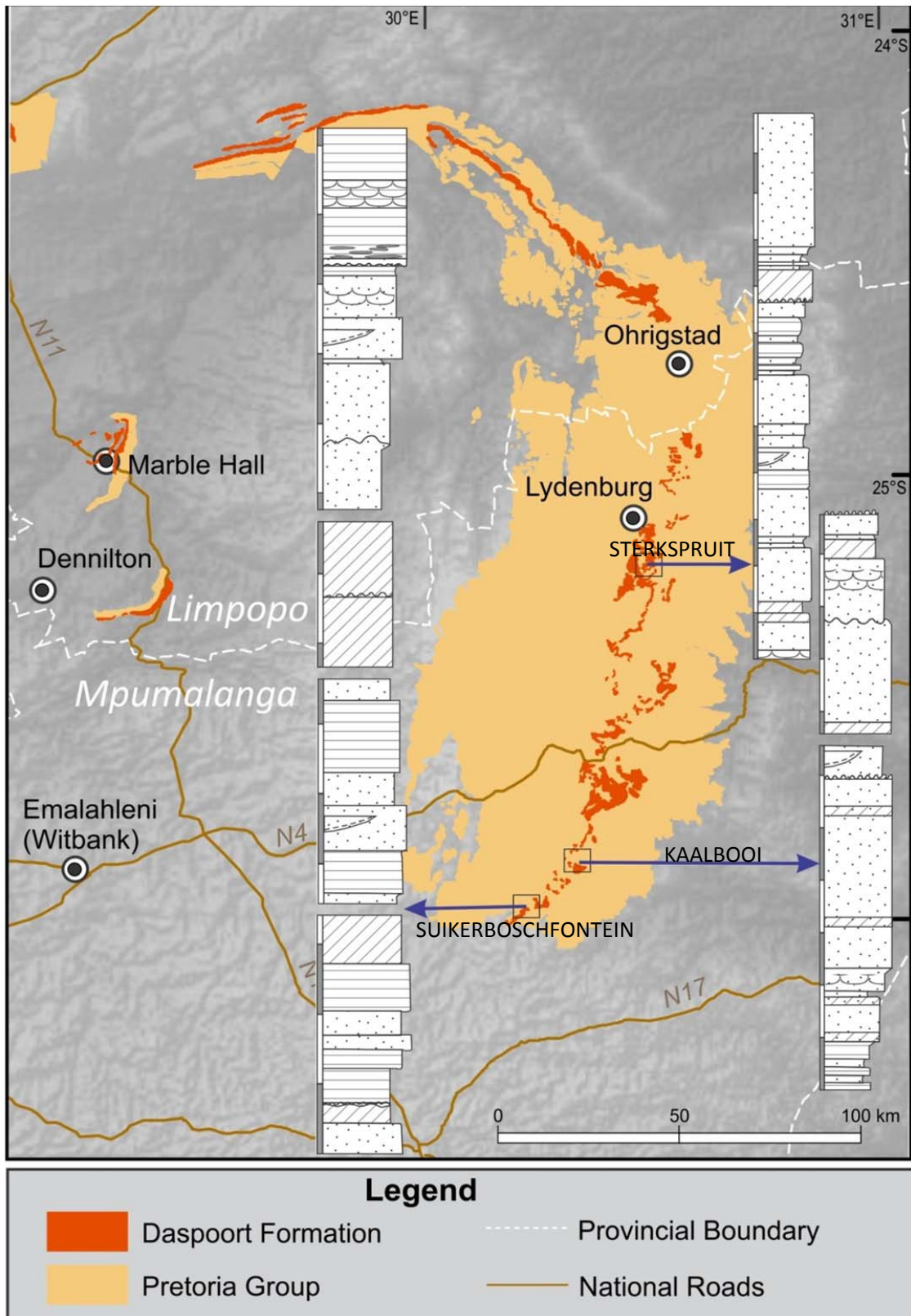

Figure 2.4: Vertical profiles generated from outcrops in the eastern Daspoort basin. The squares indicate outcrop localities (vertical profiles) of the Daspoort Formation. Each bar next to the vertical profile represents 4 m. i.e. the Kaalbooi succession is 42 m and Sterkspruit is 48 m. Suikerboschfontein has a bar scale of 7 m.

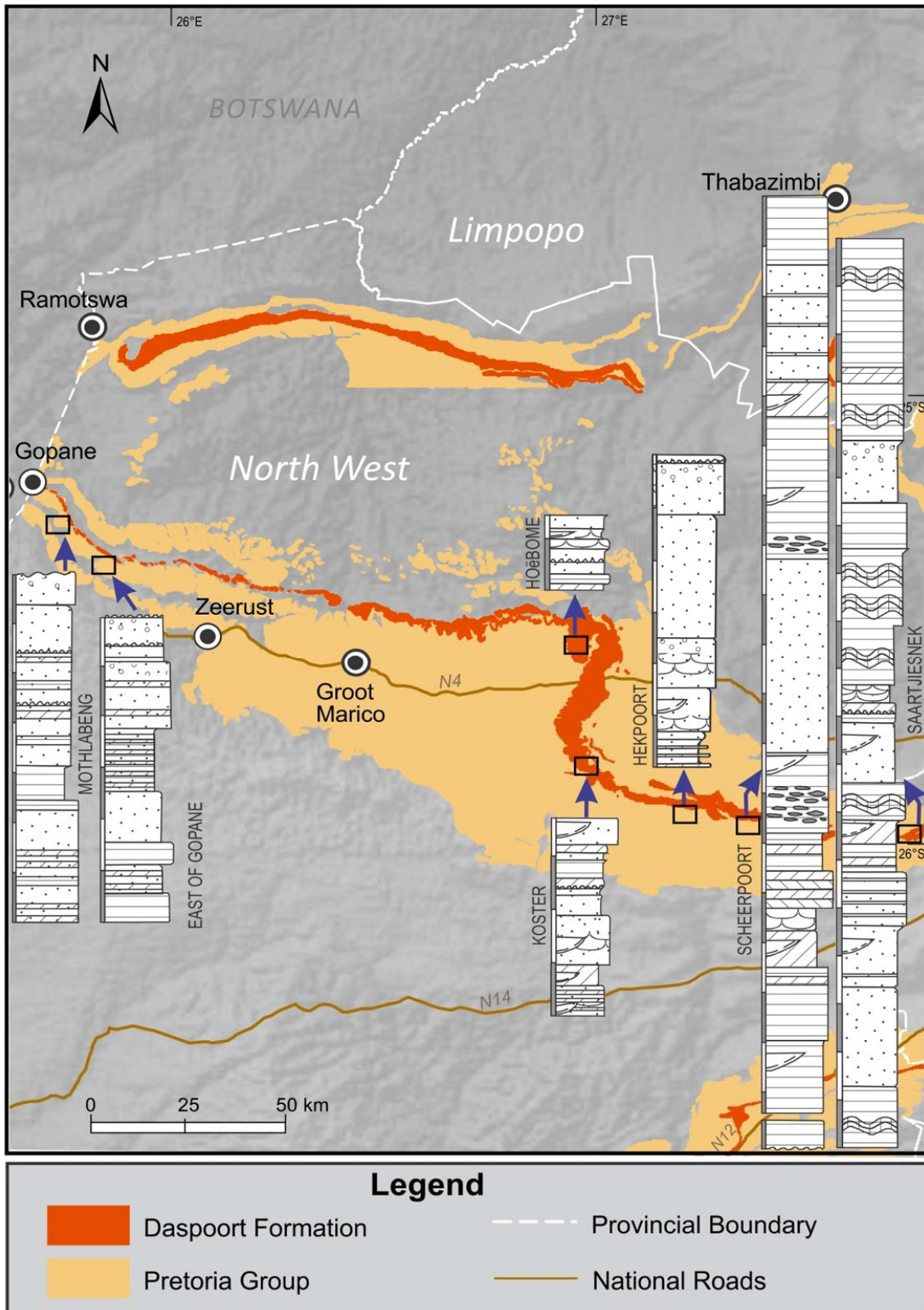

Figure 2.5: Vertical profiles generated from outcrops in the western Daspoort basin. The squares indicate outcrop localities (vertical profiles) of the Daspoort Formation. Each bar next to the vertical profile represents 4 m. i.e. the Saartjiesnek succession is 76 m. It is only the Scheerpoort succession whose scale is different; each bar representing 6 m.

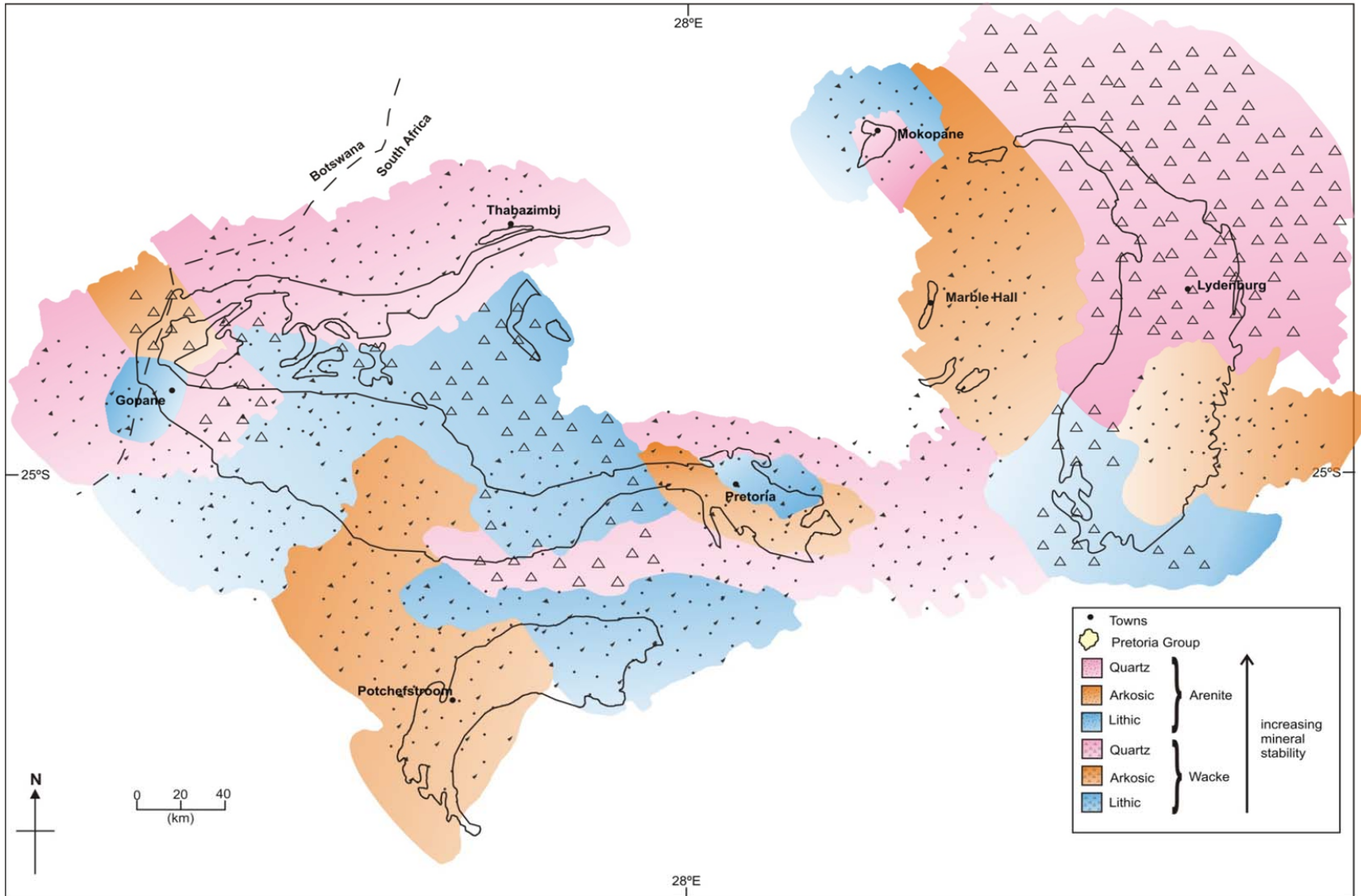

Figure 2.6: Sandstone maturity distribution in the Daspoort basin. Areas outside the outcrop perimeter are interpreted lateral distributions of lithologies. The interpolation is based on slope, strike and dip angles of Daspoort Formation outcrop on a regional scale.

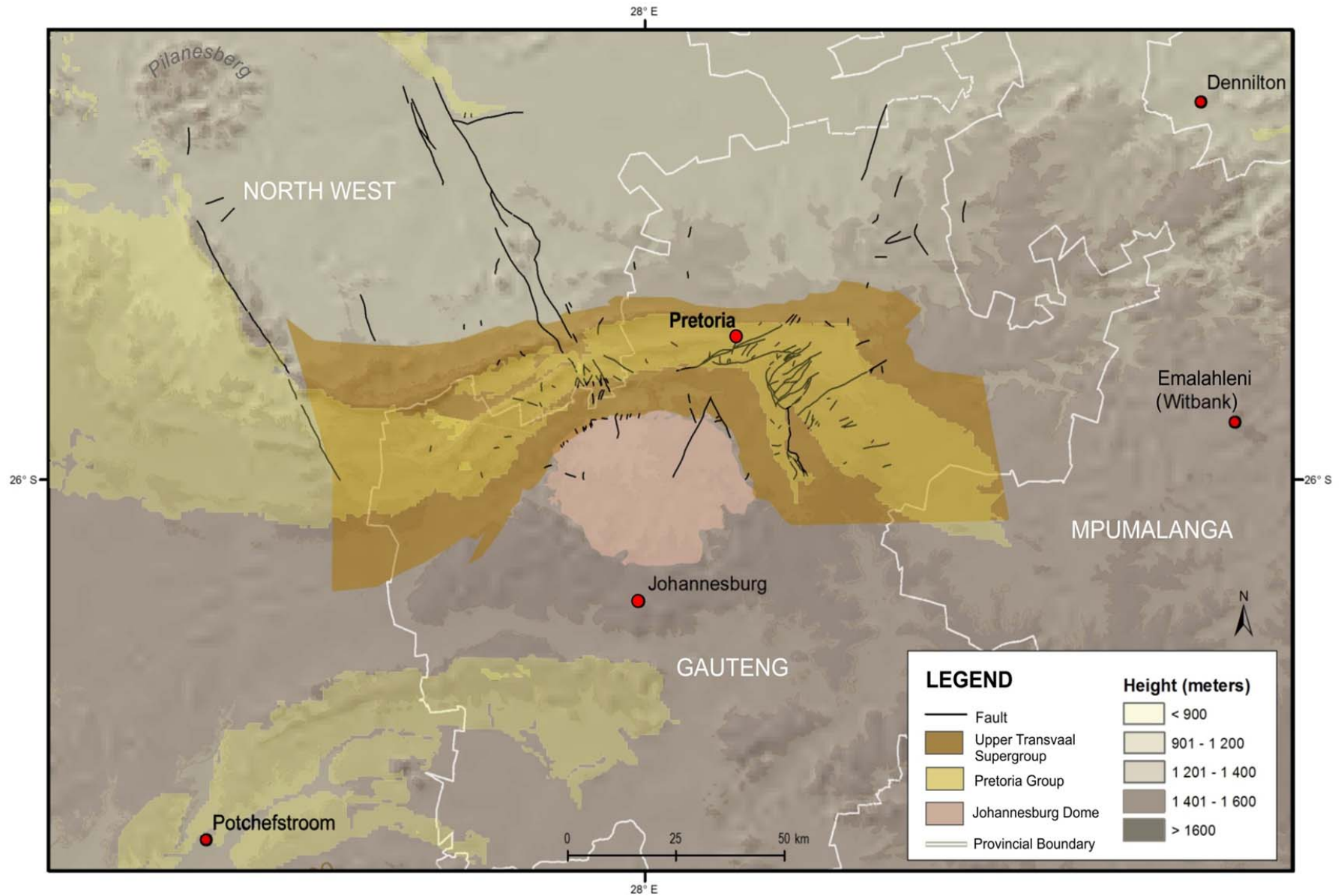

Figure 2.7: The Proterozoic Groups displayed as a unit draped around the Johannesburg Dome. Note the resulting fault lines forming a radial pattern radiating outward from the Johannesburg Dome.

The distribution of the Daspoort Formation, and on a broader scale in particular, the Transvaal Supergroup, is draped around the Johannesburg Dome as seen in Figure 2.7. This is due to the physical Archaean nature of the Kaapvaal craton when Pretoria Group sedimentation and diagenesis took place during the Proterozoic. The Archaean granitic rocks of the Johannesburg area create a local barrier where sediments progressed radially outward. Tectonic activity also prevailed in the Pretoria Group where mountains and ridges are commonly found in the central basin area (Figure 2.8). These features flatten out as one move further away from the Johannesburg dome.

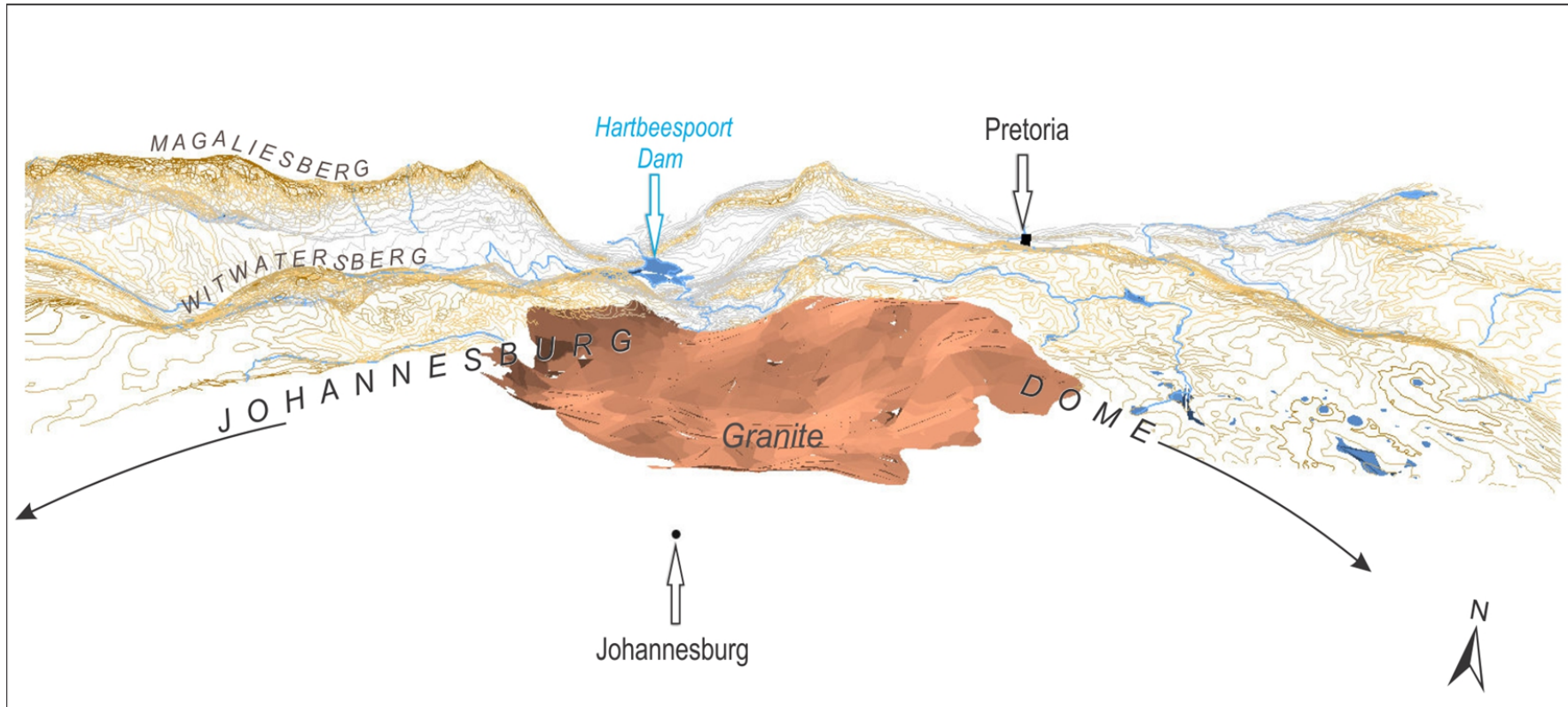

Figure 2.8: Another view of the Pretoria Group sedimentary rocks curving around the Johannesburg Dome (igneous Archaean rocks). The Daspoort Formation is part of the Witwatersberg mountain range west of Pretoria compared to the gentler sloped ridge east of Pretoria.

2.2 Facies Association

Extensive recrystallisation within the lower Daspoort units has made it difficult to conceptualise the regional distribution patterns of the described facies, and with the spatial distribution of observed palaeocurrents and ripple mark morphology. However, some clear basin-scale trends are applicable for the Daspoort depository (Eriksson et al., 2005). These are:

- Upwards-coarsening (inferred fluvial) deposits
- A general fining from west to east of the fluvial deposited sandstones
- An intimate spatial association between the finest facies and their preferential occurrence in the east of the preserved basin
- Pebbly sandstone facies cuts into the underlying finer fluvial-lacustrine/basin deposits from west to east
- Ripple mark morphology changing from west to east, symmetrical to asymmetrical
- Decreasing mudrock abundance towards the west
- Upward fining trends are subordinate to upward coarsening in the middle to upper Daspoort units
- Palaeocurrent data more prominent in the west than east

The Daspoort Formation is replete with quartzitic arenites throughout the basin, while quartzitic wackes occupy most of the central to eastern basin areas (Figure 2.6). Figure 2.9 displays an estimation of the sandstone composition of the Daspoort Formation. The distribution of sandstones identified in the field according to facies assemblages is portrayed by Figure 2.10.

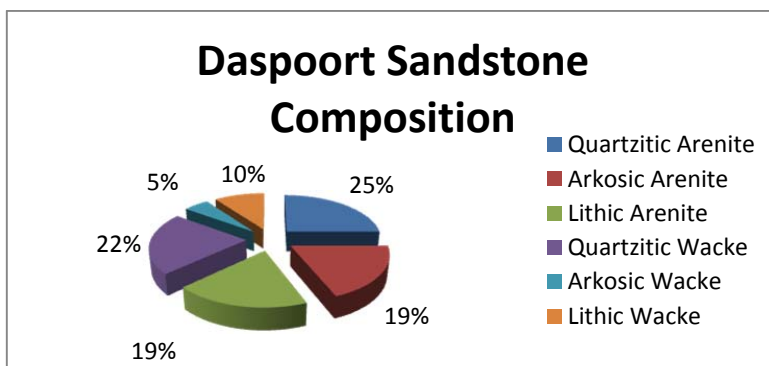

Figure 2.9: Pie chart of Daspoort Formation's sandstone composition; based on measured profiles and outcrops across the basin.

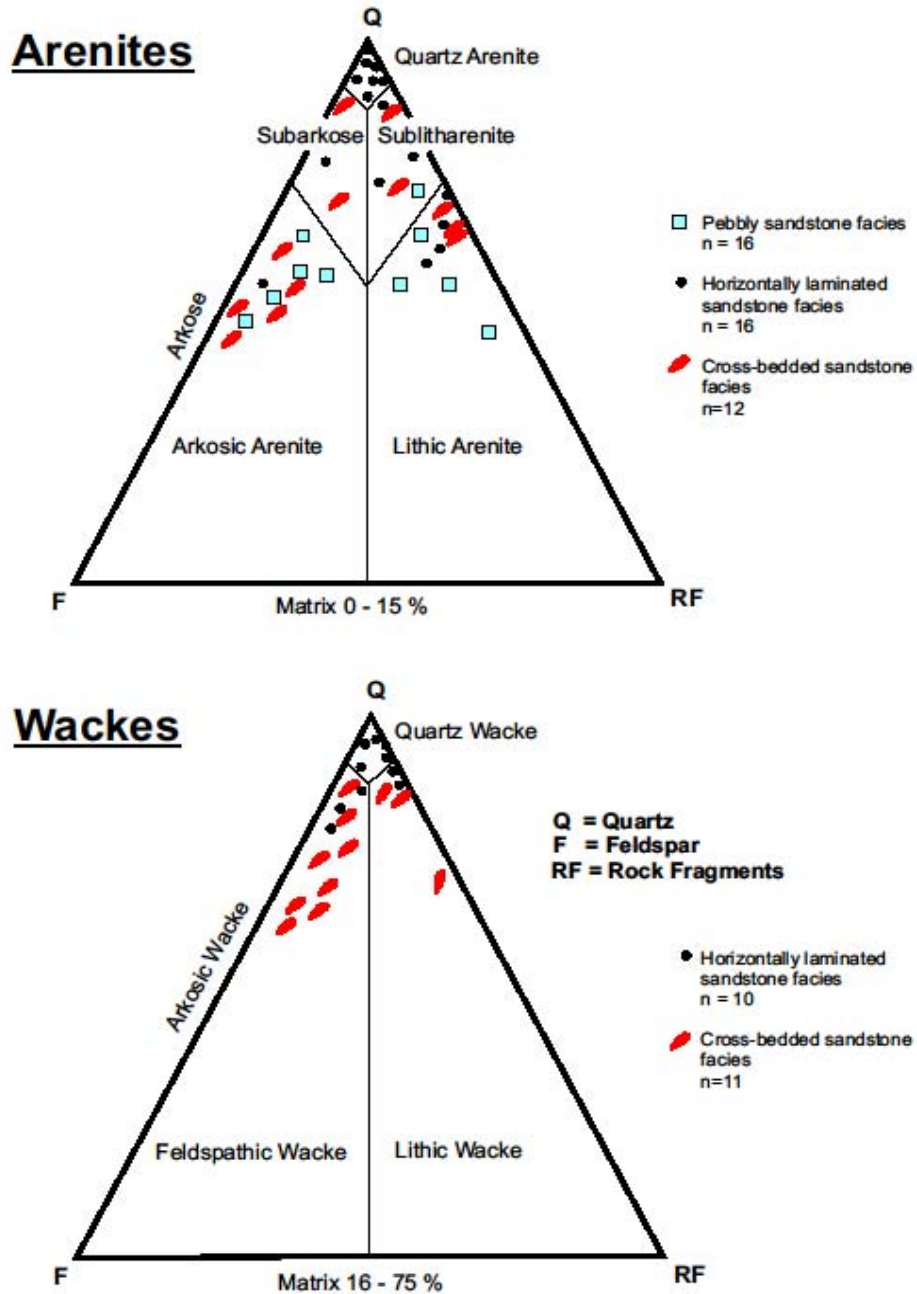

Figure 2.10: Petrographic composition of samples from 3 of the 4 described major facies assemblages, Daspoort Formation. Sub-facies assemblages are not portrayed in this figure. The fourth major facies assemblage, Mudrock, does not conform to this sandstone classification. Classification after Pettijohn et al., 1972.

Vertical profiles created from outcrops observed in the western and central parts of the Daspoort basin do often not resemble the full succession. Weathering and limited outcrops and the gentle dipping units, especially in the western basin, do hinder correlation between outcrops. Lithofacies identified in these units does create a sense of vertical position within the succession. Marker horizons such as the incised unconformity between the upper and lower Daspoort Formation units, pebbly sandstone in the upper unit, quartzite in the lower unit and interlayered mudrock towards the bottom of the lower unit contribute to identify 'events' and vertical position in the succession.

The western basin outcrops are generally believed to form part of the upper unit when the field vertical profile is incomplete. Marker horizons such as pebbly lithologies and wave ripples are associated with this unit. Pebbly lithologies are usually preceded by massive medium to coarse grained sandstone as seen in the western profiles of the Daspoort basin (Figure 2.5). These are synonymous with channel-fills and higher pulses of flow-rates, deposition and accommodation space.

The central basin outcrops are the most variable in the whole Daspoort Formation (Figure 2.3). Horizontal lamination and cross-bedded sandstone are abundantly found as thin interbeds. Other physical sedimentary structures are common. The outcrops are well defined except for the Strubenkop Formation contact. Here a gradational phase of interlaminated mudrock and thin sandstones is observed. This is superseded by mature quartzitic sandstone containing bedding patterns described above. The unconformity between the two units of the Daspoort Formation is best observed here showing characteristic undulating surfaces, load casts and other imbrications.

The massive vertical profiles of the eastern basin display a lithological homogeneity compared to the west and central areas. The upper contact or erosional surface is similar to the central basin's undulating, immature surface, but for most of the succession the lithology is massive with sedimentary structures uncommon, especially in the lower unit. Lithofacies described in the upper unit do show the biggest sedimentary structures found in the Daspoort basin, although the variety is limited (undulating surfaces, cross-bedding).

The generalised sandstone maturity distribution map (Figure 2.6) indicates a gradual distribution of lithic arenites and lithic wackes with predominantly quartz arenites. The lithic nature among the quartz arenites could be attributed to different flow regimes prevailing, especially in the central and western parts of the basin, migrating north and eastwards into the basin. Quartzitic wackes are associated with more clay minerals in the matrix composition. This is found towards the northeast where Fe-rich sandstone and mudstone are common. Arkosic arenites which are slightly more mature, occur in similar environments. Post-depositional alteration and metamorphism contributed to the maturity of the Daspoort Formation in the

Potchefstroom area. The sandstones of the central part of the basin are mature and generally moderately to well sorted, bar a few exceptions.

2.2.1 Pebbly lithologies

The distribution of pebbly sandstones is limited to the central Pretoria region and locally throughout the western parts of the basin. Isolated occurrences are seen at Suikerboschfontein and in the Pretoria Group rocks curving around the Johannesburg Dome on the eastern side thereof. The pebbly units can't be ascribed to a specific lithology, due to their nature, occurring in numerous sandstone bodies.

Sizes of pebbles vary from a couple of millimetres to up to 18 cm in diameter (Figure 2.11). The pebble size is as random as their distribution towards the west. Bedding planes with sole marks and other load cast imbrications are found below these high energy sedimentary environments, especially in the western- and central basin (Figure 2.12). Pebbles are usually found in the middle-lower Daspoort succession, at the base of a unit, in the Pretoria area. In contrast, the pebbles towards the west are found in the upper parts of the Daspoort Formation. This could be a misguided interpretation as no full outcrop extent of the Daspoort was found in the western basin; therefore observations made are subjective according to outcrop availability. Pebbles contained in this area are smaller than the Pretoria pebbles. Some of the pebbles in the Pretoria region compare to conglomeratic proportions, both in size and matrix assemblage. No *in situ* pebbles were seen in the east of the Pretoria basin, but thin mud layers showing evidence of rip up clasts, various subrounded remnants of medium to large sized pebbles and flattened examples were sporadically located in the south eastern parts of the basin (Figure 2.13).

Larger pebbles often are generally associated with smooth, round edges. Pebbles smaller than 1.5 cm in diameter, are angular. The pebbles are of different compositions, especially the wide variety encountered east of Gopane (Figure 2.14). Flattened empty pebble voids are found in the east of the basin. They occur with channel-fills in the area, where upward fining sequences dominate.



Figure 2.11: Silica pebbles found near Faerie Glen. Note the striation marks.

A characteristic white quartzite bed under a pebble layer is prominent in the south eastern parts of the basin as well as in the Pretoria region. The pebbles are to large extent recrystallised silica in quartzites in the vicinity of Pretoria. These are randomly scattered in the silica dominated matrix. Other locations show a differentiated character for the pebbles. The pebbles have either a muddy composition - Fe-rich, comprised of sand grains within such a matrix (Figure 2.11) or have forms resembling shell-like fragments, while small rock fragments are the scarcest. The shell-like fragments are bound in a thin layer, by a matrix consisting of mudclasts. Some of the study areas only show evidence of previously inhabited grain impressions, from which the pebbles have since been eroded. Striation marks on these lithologies are found at Faerie Glen (Figure 2.11). Planar cross-bedding with subordinate trough cross-bedding is seen wedged between high energy cycles in the Koster road cutting (Figure 2.15). The coarse to pebbly units are bounded to these sedimentary features by a lithic dominated matrix, thus being susceptible to erosion and deterioration of the visible succession.



Figure 2.12: Thin horizontally laminated beds exposed in a step-like manner. Flattened sole marks and subrounded clast remnants on the bedding planes indicate coarse fragments transported in a high energy environment.

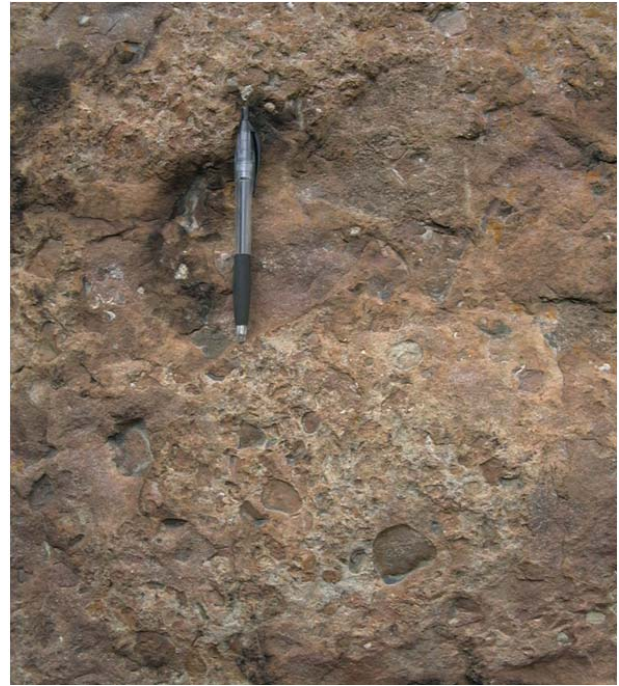

Figure 2.13: Various pebble sizes left imprints on the bedding plane. Their shapes also differ from one another. This is indicative of a high turbulent nature of the palaeo-environment.



Figure 2.14: Coarse sandstone overlain by an even coarser shell-like mud clast-bearing unit. Photo taken at Mothlabeng.



Figure 2.15: Very coarse planar cross-bedded sandstone near Hekpoort. Note the trough cross-bedding below the pen.

2.3 Palaeocurrents

The Daspoort Formation displays a wide variety of palaeocurrent directions. This is evident from the large amount of cross-bedding and channel-fills in these units. This could be indicative of a current-dominated environment where interlayered fine- and coarse-grained sands were thoroughly reworked. The relatively high maturity of the Daspoort sandstones is probably as a result of extensive reworking in the basin. This could also have an effect on the scarcity of current ripples and explain the dispersed palaeocurrents directions found in the basin.

The eastern Daspoort Formation has a predominant transport direction towards the north-west (Figure 2.16), while the western basin has more variable readings (Figure 2.17). Predominant current directions in the western Daspoort basin are towards the north-west and east-north-east. These rather variable results found throughout the Daspoort Formation are due to the common occurrence of outcrops in the west compared to the scarcity of good outcrop in the east (or inaccessible terrain). The western part of the basin displays the most variable distribution of flow directions of the three study areas. A strong influence from the south and south-west is observed. Ripple mark sizes differ in this area. They also show variable symmetry; therefore these could be classified as wind, water or current ripples. Easterly directed transport indicators are found in the western Daspoort Formation and subordinately in the central parts as well.

Strike directions of channel-fills in the whole of the Daspoort Formation are largely concomitant with current directions of that locality. This is prominent in the Carolina region where channel-fills have northwest-southeast (NW-SE) and northeast-southwest (NE-SW) orientations. These natural cross-directed currents are synonymous with the cross-bedded beach environment envisaged by Button (1973) for this area, but the presence of other features such as microbial mat features (discussed later) necessitate further discussion.

Stereo data from ripple marks observed across the Daspoort Formation indicate various sediment transport directions. If divided into three study areas; west, central and east, more prominent flow regimes are established.

Ripple marks were scarce in the south-eastern part of the Daspoort basin. No field data was acquired for the north-eastern parts of the basin. The unanimous flow direction for the massive ripples is towards the west and north-west (Figure 2.16). Ripple marks observed are both symmetrical and asymmetrical (see ripple marks sub-chapter for explanation), making a hypothetical depositional environment description obsolete.

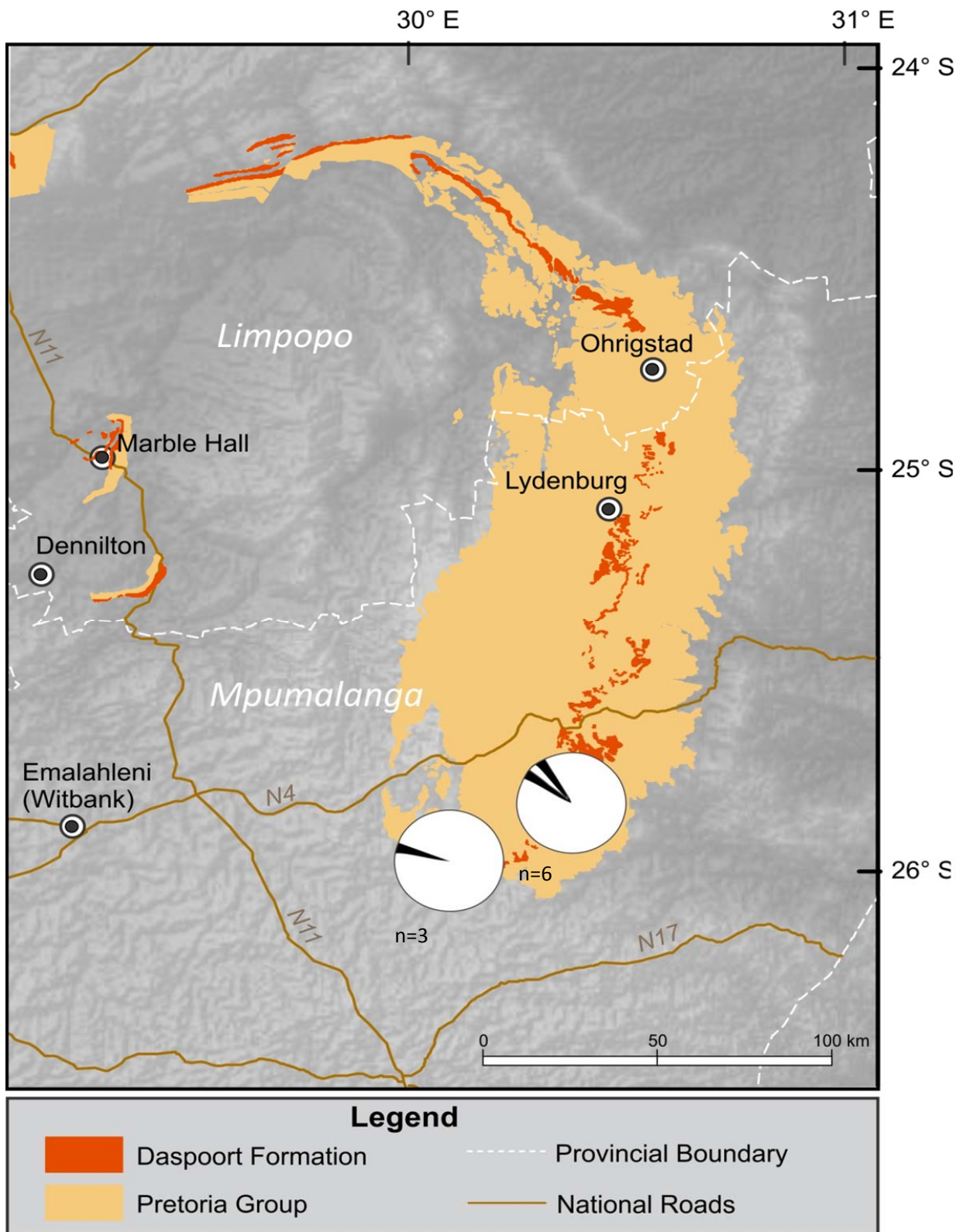

Figure 2.16: Ripple marks indicate transport direction from the south-east. n = amount of measurements.

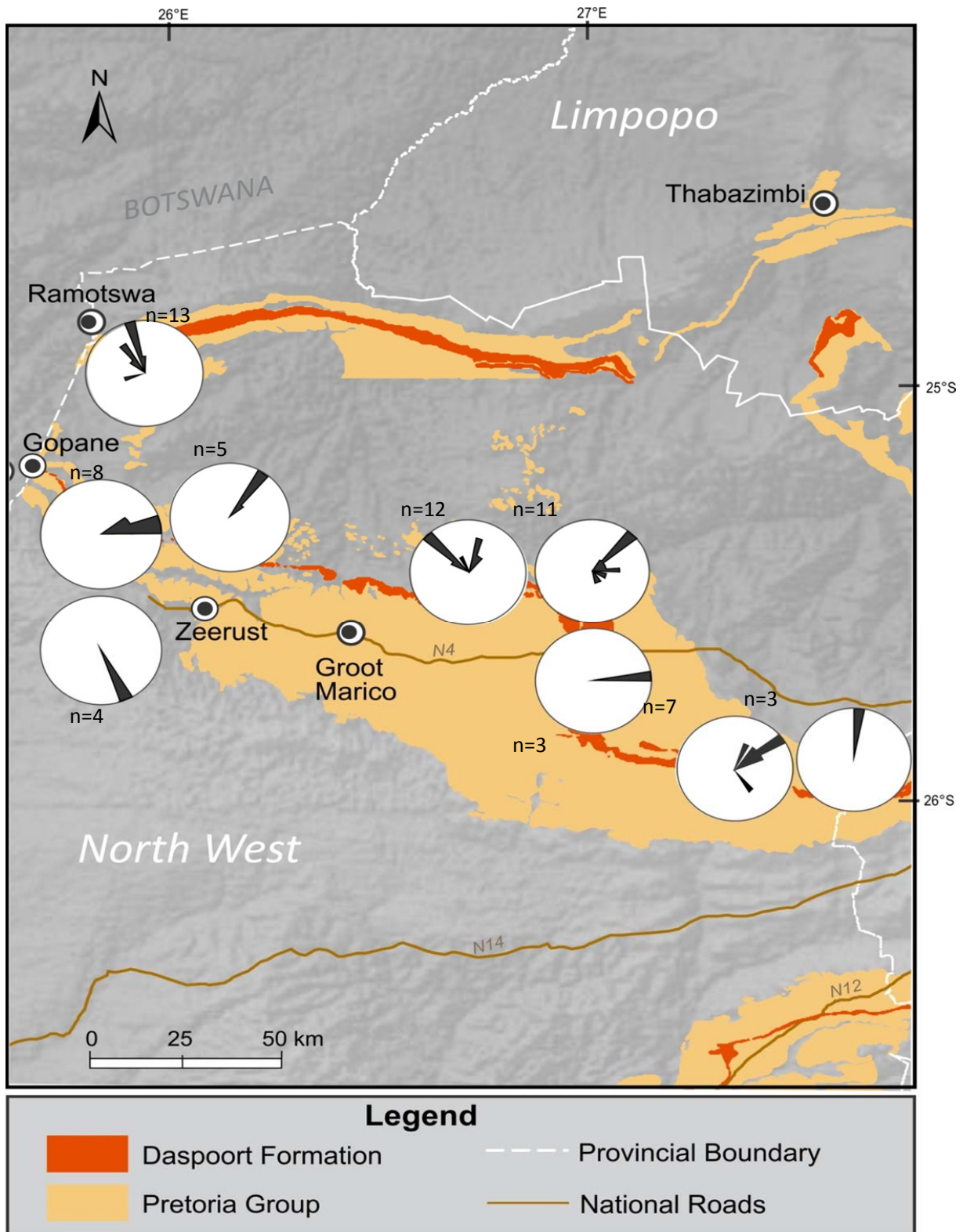

Figure 2.17: Ripple marks indicating various flow regimes for the western basin. The predominant direction of flow is towards the east north-east (ENE). n = amount of measurements.

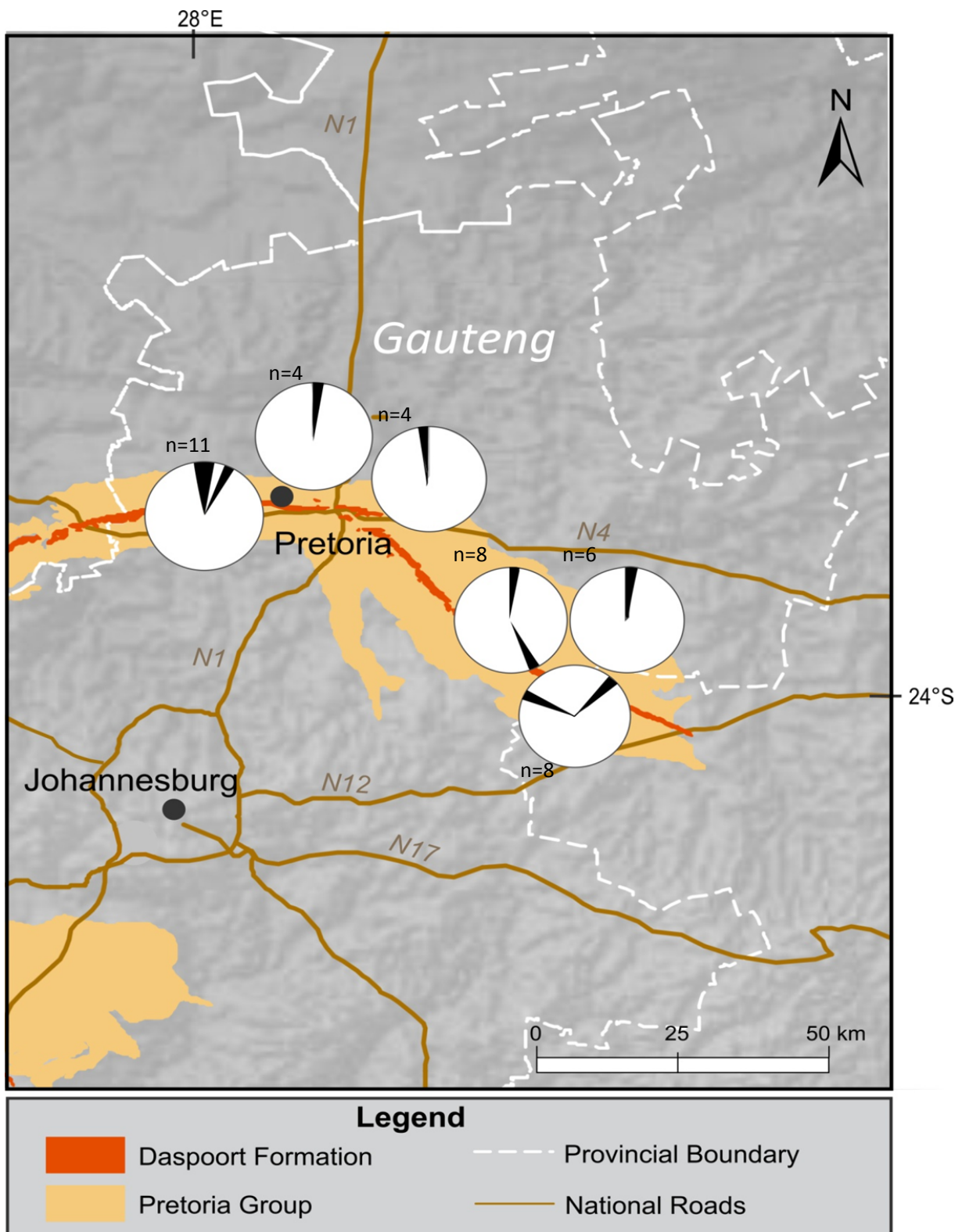

Figure 2.18: Ripple marks indicating flow directions towards the north in the central basin. Subordinate regimes are evident as well. n = amount of measurements.

The central basin has unimodal flow directions except for isolated occurrences. Northward flow directions dominate palaeocurrents (Figure 2.18). The general dip of the lithofacies containing these ripple marks are also towards the north and very steep in the Pretoria area (compared to elsewhere in the Daspoort Formation). This can be attributed to diagenesis and sedimentation of the Transvaal Supergroup curving around the semi-circular Johannesburg ancient granite (Figure 2.7). Ripple marks were mainly asymmetrical.

2.3.1 Ripple marks

Ripple marks have a close relationship with lithofacies and palaeoenvironmental data. It is imperative to have the correct grain size measurements in order to support Tanner's (1971) models and equations for elucidating such palaeoenvironmental inferences. His methods are the most reliable, but provide essentially estimates rather than fully constrained interpretations. In order to make use of the field data in this methodology, some parameters need to be addressed. Figure 2.19 below illustrate a basic understanding of waves in general.

There are 2 main types of ripple marks, symmetrical (oscillation ripples) and asymmetrical ripple marks (Figure 2.20). The former indicates the back and forth movement of water, usually associated with a shoreline environment and more generally with wave motion, whereas asymmetrical ripples are generated by wind or water moving in a single direction (Miall, 1984). Asymmetrical ripple marks are also referred to as current ripple marks.

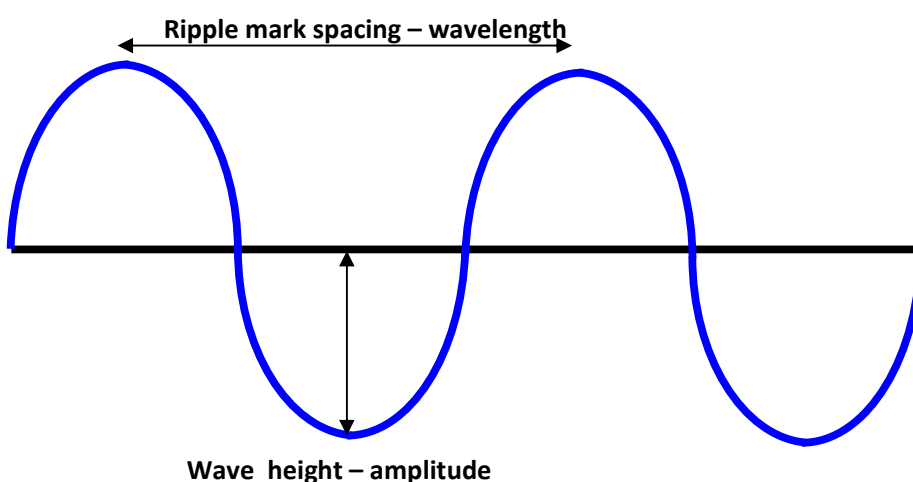

Figure 2.4: The basic concept of a wave.

Wavelength and amplitude (cf., height) of ripples were recorded in the field. From this an estimate value for grain size can be calculated by rewriting Tanner's (1971) formula for wave height:

$$H = 38.52 + 1.89s - 7.11 \ln g \longrightarrow \ln g = (38.52 + 1.89s - H) / 7.11 \quad (1)$$

Where H = wave height (cm)

s = distance between ripples (cm)

$\ln g$ = grain size (μm)

Most of the ripples observed show moderate sinuosity and there is an overall lack of double-crested, flat-top and ladder ripples in the exposures of the Daspoort Formation (Figure 2.21).

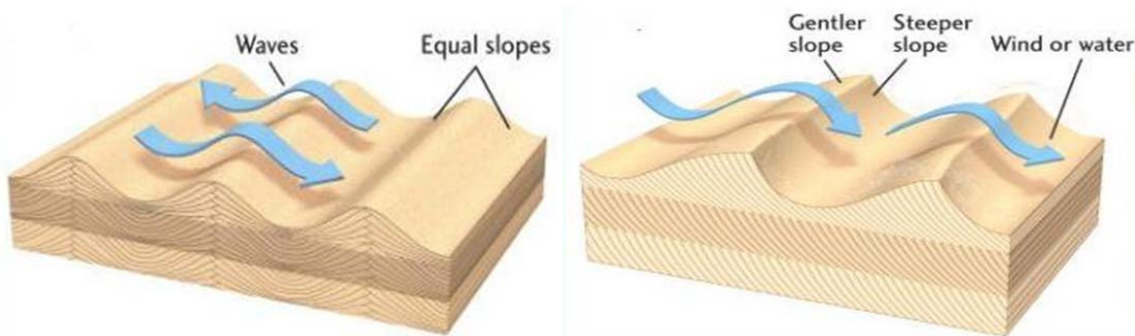

Figure 2.20: Different ripple marks formed due to different flow regimes. On the left is an example of asymmetrical ripples and the right symmetrical ripples. Images acquired from Florida State University Geology notes (see <http://www.gly.fsu.edu/~salters/GLY1000/11Sed>).

Grain size calculations are done for comparison with the measurements from thin sections and to test the merit of the formula. In order to calculate the water depth the following calculation from Tanner (1971) is used:

$$\ln h = 22.74 + 0.97s - 3.72 \ln g - 0.41H \quad (2)$$

Where $\ln h$ = water depth (cm) and other values remain as in formula (1) above.

According to Neuendorf (et al., 2005) **fetch** is the distance over which a constant and uniform wind generates waves, measured horizontally in the direction of the wind. This is a somewhat arbitrary concept, especially considering all the determining factors influencing the calculated results. Fetch is not applicable in fluvial settings, explaining the negative values obtained below. It is accepted that the information in Table 3 is based on symmetrical wave patterns or at least where they predominate.

Table 3: Average ripple mark parameters measured across the Daspoort basin.

<i>Location</i>	<i>Ripple mark spacing s (cm)</i>	<i>Grain size In g (μm)</i>	<i>Wave height H (cm)</i>	<i>Water depth In h (cm)</i>	<i>Fetch In f (km)</i>
Paul Kruger Rd.	4	6.48101266	0.6	19.66777841	-2.38869
Soutpansberg Rd.	4.5	6.61392405	0.4	20.07726107	-3.27584
Nkwe	10	8.07594937	2	24.6693276	0.245606
Hans Strijdom Dr.	12	8.60759494	10	26.3721608	3.767056
Faerie Glen	18	10.2025316	3.5	31.55979449	1.470045
Swavelpoort	4	6.48101266	1.5	19.66777841	-0.38384
Gopane	5.5	6.87974684	1.2	20.9006755	-0.87208
Kaalbooi	60	21.3670886	7	69.54991122	2.986651
Mesheu	5.5	6.87974684	1.5	20.9006755	-0.38384
Hekpoort	9	7.68354430	0.9	23.51561891	-1.501

It is obvious that some of the values in Table 3 are misleading. There are various formulae to use for specific circumstances. This is evident in Table 4 where fetch can be estimated from different formulae.

Table 4: Various fetch results using the same input values, only different estimation formulae.

<i>Location</i>	<i>Fetch In f (km)</i>	<i>Fetch In f (km)</i>	<i>Fetch In f (km)</i>	<i>Fetch In f (km)</i>
Paul Kruger Rd.	-0.0976	-3.98387677	0.019482	-2.38869
Soutpansberg Rd.	-0.1464	-5.19931063	0.005713	-3.27584
Nkwe	0.244	-0.54258104	0.644275	0.245606
Hans Strijdom Dr.	2.196	4.19531644	77.89097	3.767056
Faerie Glen	0.61	0.97475213	3.052791	1.470045
Swavelpoort	0.122	-1.26432588	0.304408	-0.38384
Gopane	0.0488	-1.96206222	0.15119	-0.87208
Kaalbooi	1.464	2.5713493	16.45151	2.986651
Mesheu	0.122	-1.29977216	0.295293	-0.38384
Hekpoort	-0.0244	-14.7529550	0.060133	-1.501
	Eq(3)	Eq(4)	Eq(5)	Eq(6)

$$\ln f = 0.244 (H - 1) \quad (3)$$

Where $\ln f$ = fetch

$$\ln f = 2.968 \ln H - 0.583 \ln h - 0.731 \quad (4)$$

Which can be approximated by:

$$f = 0.4 H^3 h^{-0.5} \quad (5)$$

When the water depth data are excluded from the equation, it becomes:

$$\ln f = 2.188 \ln H - 1.271 \tag{6}$$

The latter equation is probably the better to use, lending itself to less corrupted parameters than the former equations.

Taking into account the results from Table 3, a visual interpretation of the water conditions from the west to the east of the Daspoort basin can be portrayed. Graph 1 illustrates the initial homogeneous water depth and wave height from the west moving eastwards. A gradual increase in both parameters in the central basin follows with maximum results in the far eastern basin.

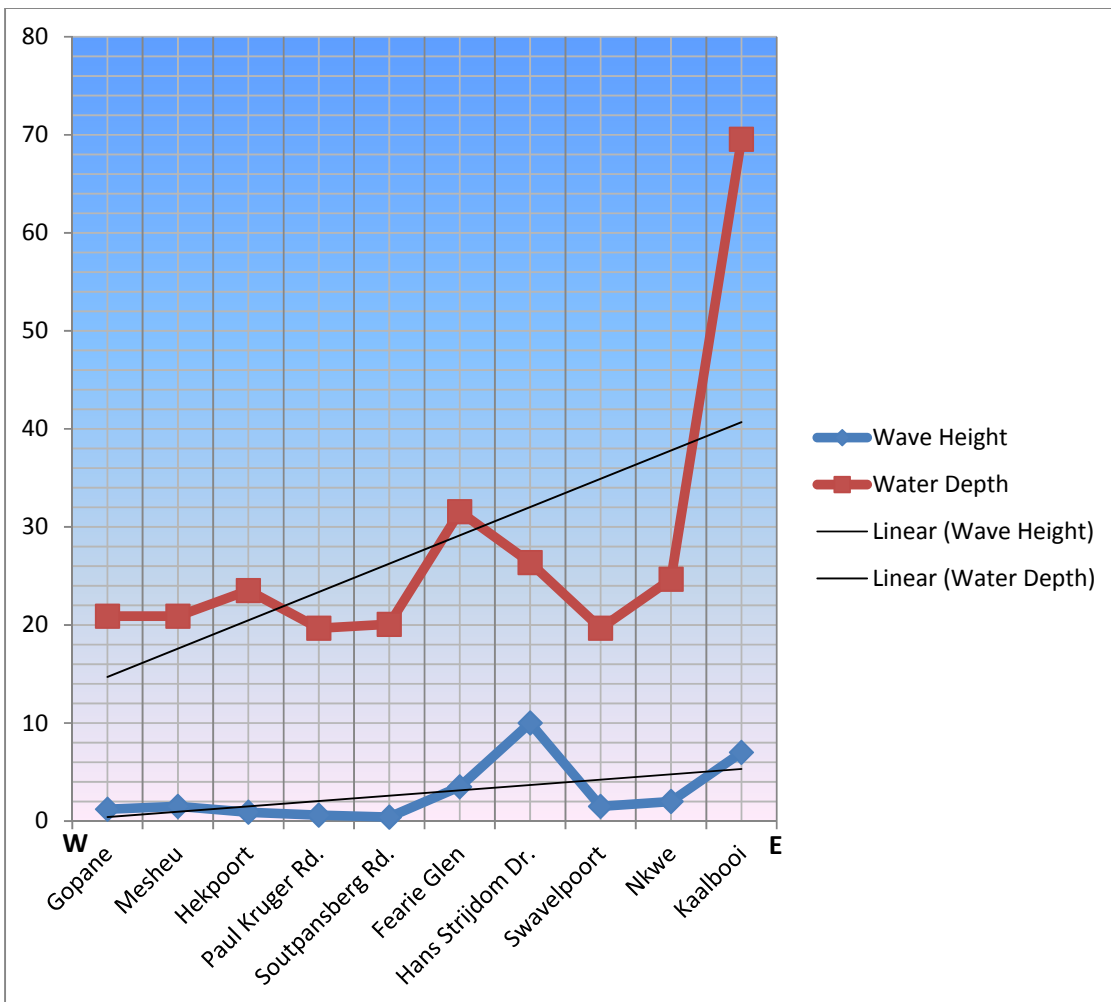

Graph 1: Daspoort Formation water depth (cm) and wave height (cm). Values used from Table 3 to indicate basinal West-East trend of wave height and water depths. This graph is based on ripple mark field data. Note the upward trend towards the east.

The water depth in the western basin is much shallower compared to the eastern basin (Figure 2.21). Not only ripple mark calculations, but the sheer scale of sedimentary features in the western basin is subordinate to their counterparts in the eastern parts of the basin. The lower water levels and almost absent waves in the western basin support a current dominated setting. As base level rose, the basin began to fill up from the west. The strong linear increase of water depth compared to a more gradual increase in wave height indicates that shallow epeiric marine conditions did not dominate the depositional environment. The basin was rather more conducive to fluvial or alluvial conditions. It is only towards the east where a stronger marine influence is possible. The low wave heights are indicative of a shallow epeiric coastline. This means the low energy supports a tide dominated setting instead of a wave dominated environment. The preservation of ripple marks in the eastern basin depicts a low energy shallow marine environment as waves would destroy such features.

One might argue that the trend in Graph 1 might somewhat be distorted towards the east, but a big distance (lateral extent/kilometres) exists between Nkwe and Kaalbooi. Unfortunately no field data exists in between due to inaccessible terrain, poor outcrop or the absence of ripple marks. It is therefore suggested that the trend can be interpreted soundly if the scale of the Kaalbooi ripple marks is taken into account.

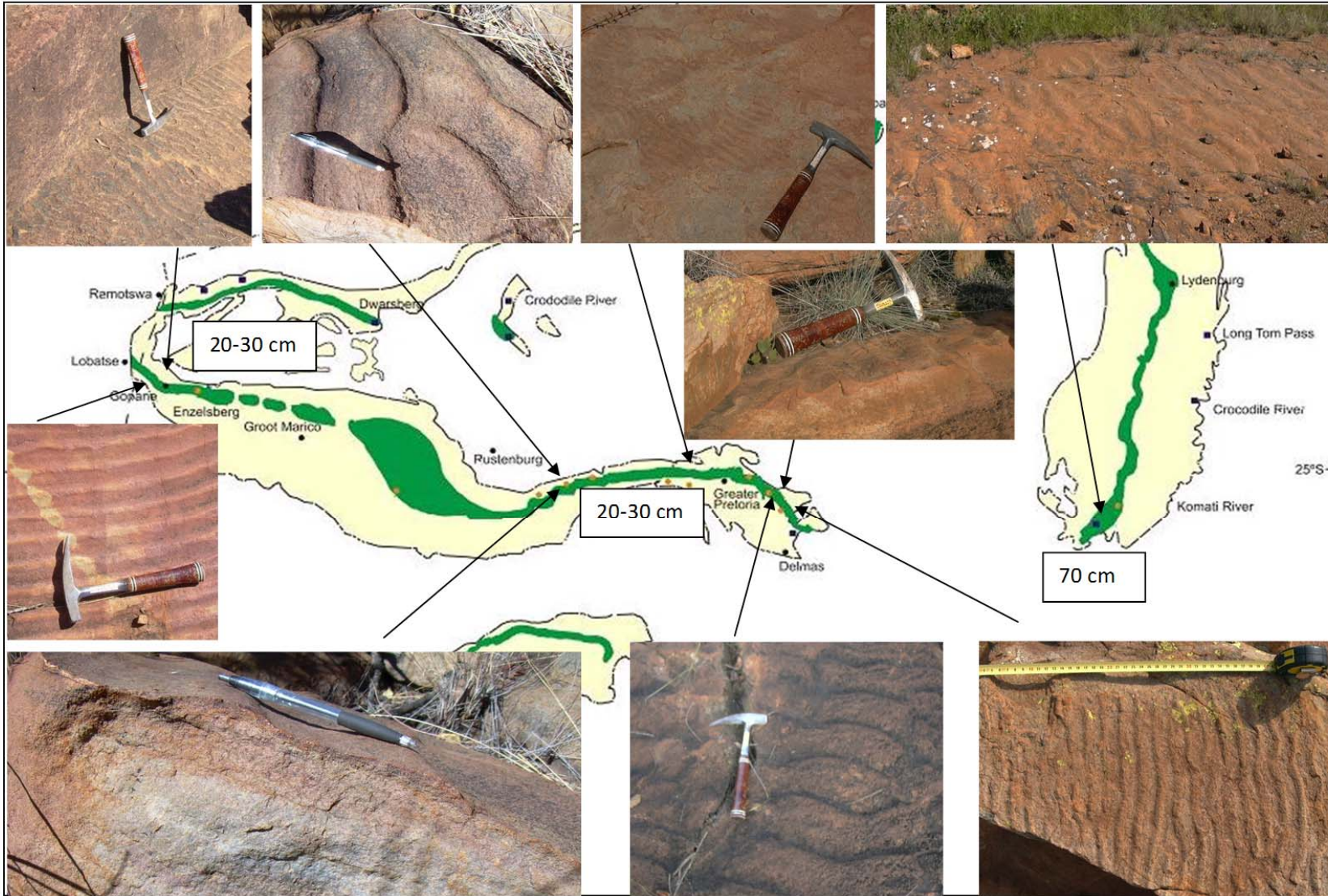

Figure 2.21: Average ripple mark size distribution and estimated water depth across the Daspoort Formation. The photos indicate approximate ripple mark sizes. The ripple marks at Kaalbooi (top left) are the biggest found in the Daspoort Formation (wavelength <math><60\text{cm}</math>).

2.4 Petrography

Optical petrography of the Daspoort sandstones delivered little substantial evidence of (dia)genesis of these principally arenites. Arkosic arenites are littered throughout the basin with feldspathic wackes, subarkoses and quartzitic wackes commonly found as well (Figure 2.10). Quartz obviously dominated the matrix minerals (>70%) followed by feldspar (20%) and subordinate secondary Fe-rich oxidised minerals making up the other 10% along with micas and heavy minerals. Rock fragments are uncommon in the sandstones. Recrystallised quartz grains are common in the Daspoort samples from the west of the basin. Fe-oxide minerals form concentric layers surrounding quartz grains. These minerals also fill voids in the matrix. Triple junctions are common between grains, indicating some metamorphic activity and secondary growth. The post- Pretoria Group, Bushveld intrusion is most probably the cause of these features. The Vredefort (ca. 2030 Ma) impact structure exposes Pretoria Group sedimentary rocks in the Potchefstroom area where they have similar metamorphic properties.

The moderately sorted arenites of the central Daspoort basin (Figure 2.22) could be indicative of a high energy environment. Apart from the fact that they have a limited speckled appearance, these rocks are predominantly light in colour, especially in the central Daspoort Basin.

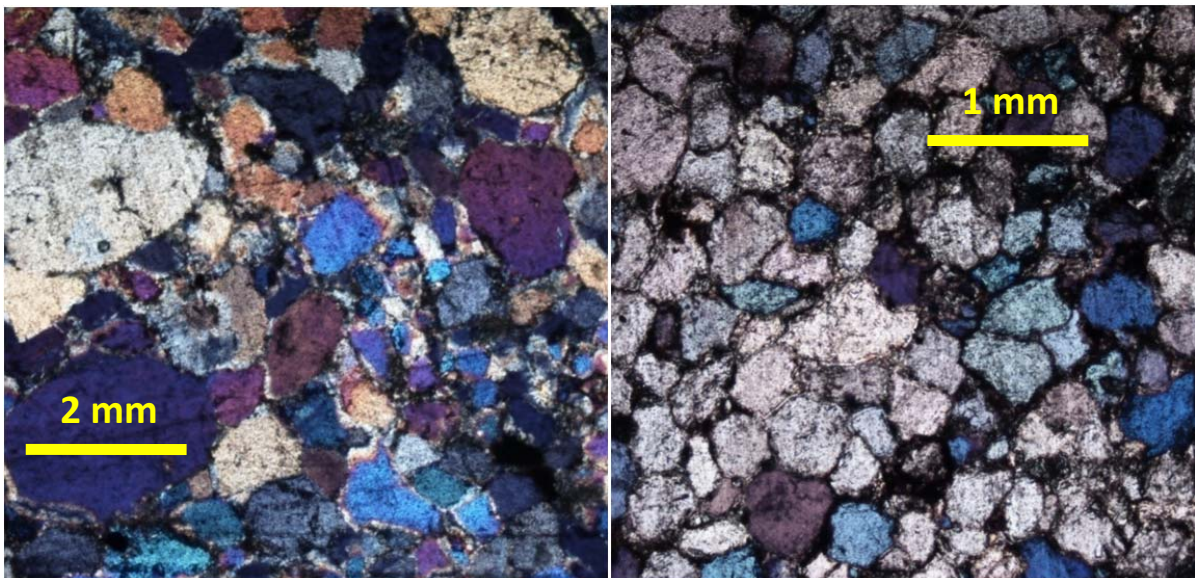

Figure 2.22 (left): Poorly sorted, immature sandstone from the central basin. Note the various grain sizes and grain boundary overgrowth rims. Figure 2.23 (right): Mature quartzite from Saartjiesnek. Secondary sericitic weathering products are seen in between well compacted silica grains. Microscopic view: crossed polarised light.

Due to the homogeneity of Daspoort sandstones' mineral assemblage under the microscope, one can use sorting to help substantiate an inferred depositional environment. Quartz arenites are abundant in the Daspoort Formation; hence they depict geological significance which can be summarized as follows:

- Mature petrography
- Distribution (on craton or margins)
- Genesis
- Sheet-like geometry

The figures show recrystallised quartz grains with smooth and angular grains shapes prevailing in the central (Figure 2.22) and western (Figure 2.24) regions. The visible very coarse grains can reach a diameter of up to 7 mm. Small angular feldspar inclusions were found in some quartz grains, suggesting that this is a reworked sedimentary rock or indicate a granitic source rock which has undergone physical alteration during transport and diagenesis. Subordinate mica amalgamated with calcite forms an interstitial matrix and cement between grains. The feldspar grains are mostly fresh, but some strongly altered examples occur in thin sections, especially those from the central and eastern Daspoort Formation. Differentiation was made between plagioclase and K-feldspar, but poor preservation of primary minerals made identification difficult. Mostly lithic fragments of Potassium-feldspar and oxidized minerals are found in coarse sandstones, while zoning, secondary epidote and chlorite mineralization showing weak pleochroism are evident in the finer sedimentary rocks. The massive quartzitic units observed just 50 km west of Pretoria, at Saartjiesnek, have quartz grains which show undulatory extinction under cross polarization and display polycrystalline properties. Note the bimodal grain size and grain shape in the Saartjiesnek quartzite (Figure 2.24).

The western parts of the Daspoort basin's sandstones have an arkosic nature. These are made of rounded grains which are cemented together by a fine matrix of opaque minerals. These minerals, displaying a brownish countenance, are believed to be secondary iron oxide minerals. The quartz and feldspar grains in the arkosic rocks are believed to represent the weathered products of granites (Figure 2.24 and Figure 2.25). There is a strong decrease in inferred granitoid-derived detritus moving eastwards across the Daspoort Basin. These immature western compositions are replaced by low-grade metamorphosed sedimentary rocks in the central Daspoort basin, where recrystallised quartzitic sandstones are common.

Cementation is observed in the immature sandstones of the Daspoort Formation, especially towards the western basin. Although this is not common, it does occur in the form of altered quartz, clay minerals, oxides and minor amounts of calcite. Overgrowths of quartz grains are observed in the poorly sorted sandstones of the central basin where they grow in between grains, filling the voids. An interlocking grain texture is common in such sandstones.

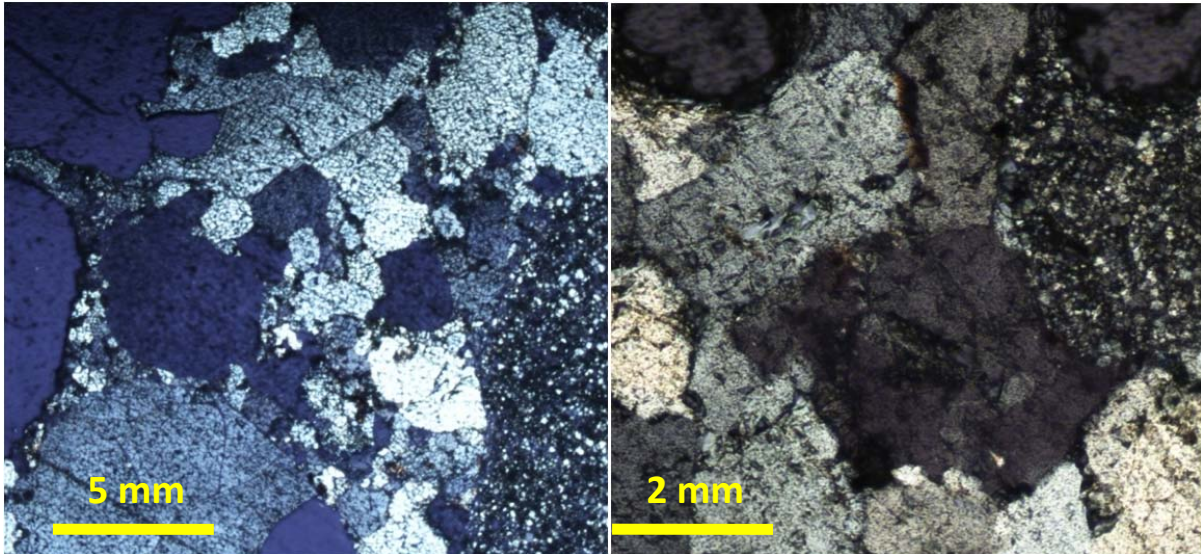

Figure 2.24 (left): Bimodal grain properties observed in the Hekpoort site lithic wackes. Variable sizes, degrees of alteration and shapes (smooth and angular) are evident. **Figure 2.25 (right):** Transitional grain boundaries in altered sandstone of the Hekpoort area. Microscopic view: cross polarized light.

2.5 Geochemistry

Three samples were prepared for XRD analysis using a back loading preparation method. The samples were analysed at the Department of Geology, University of Pretoria, on a PANalytical X'Pert Pro powder diffractometer with X'Celerator detector and variable divergence – and receiving slits with Fe filtered Co-K α radiation. Samples were prepared with the standardized Panalytical back loading system, which provides nearly random distribution of the particles. Measurements were made from 5° to 90°2 θ with a calculated step size of 0.017°2 θ . The phases were identified using X'Pert Highscore plus software. The relative phase amounts (weight %) were estimated using the Rietveld method (Autoquan Program). Amorphous phases, if present were not taken into consideration in the quantification.

X-diffraction is used to determine crystalline phases present in a sample. In this case the crystalline phase can be associated with a mineral phase composition and the sample/material is the rock sample. Most crystalline materials have unique x-ray diffraction patterns that can be used to differentiate between materials. This is a very powerful and efficient technique to identify unknown minerals. Using XRD is the most non-destructive method to characterize minerals such as quartz, calcite, feldspars and other clay minerals. These minerals are predominant in the Daspoort Formation. The element composition as displayed in Table 5 makes data interpretation easy to determine mineral assemblages. The three samples represented separate facies assemblages (see supporting Figure 7.22, Figure 2.23 and Figure

2.24 in Appendices). The first, a dark microbial mat type layer covering coarse sandstone, yielded high amounts of silica and subordinate elements: Na, Fe, Al and B. The latter element indicates a possible tourmaline presence, possibly elbaite as inferred also from the green needles observed under the optical microscope. This sample was found in the Gopane region, at Mothlabeng (Figure 2.26).



Figure 2.26: Symmetrical ripple marks covered by a thin cracked sandstone layer (petee ridges), interpreted to reflect a pre-existing microbial mat, near Mothlabeng.

Secondly, a whole rock analysis, giving element compositions, of a coarse arenite delivered a similar abundance of these elements with K, Mg, F and Ti added to the composition. The last sample is a mudstone layer from the upper Daspoort's sandstone bedding planes. XRD results suggest an abundance of clay minerals such as illite and kaolinite, while Fe-minerals, goethite and hematite, gave the strongest peaks.

Table 5: Normalised values of element abundance of the coarse Daspoort sandstones. The right hand column indicates weight percentage of elements should SiO₂ be omitted from the composition.

SiO ₂	90.6	%
TiO ₂	0.3	3.284592
Al ₂ O ₃	2.0	21.38804
Fe ₂ O ₃	2.8	30.77259
MgO	0.3	2.946312
CaO	0.5	4.943256
Na ₂ O	0.4	4.681362
K ₂ O	0.1	1.331296
P ₂ O ₅	1.4	15.38629
Cr ₂ O ₃	0.1	1.440419
ZrO ₂	0.1	0.67656
SO ₃	0.1	0.665648
BaO	0.3	3.142732
Cl	0.5	5.172414
P	0.2	2.062418
Cs ₂ O	0.1	1.342209
S	0.1	0.763859

Only one sample, from the western region of the Pretoria basin, was studied under the XRF spectrometer using UniQuant software. For a detailed geochemical study on these sandstones, see Reczko (1994). The software analyzed all elements in the periodic table between Na and U, but only elements found above the detection limits were reported. The values were normalised, as no LOI was done to determine crystal water and oxidation state changes. All elements were expressed as oxides.

Silica is by far the biggest component of the Daspoort sandstones. The Al: Fe ratio is 2:3 with P being half the amount of Fe. The other oxides are far less abundant. Subordinate to P are CaO, Na₂O and Cl (see Table 5) and Appendix A for tabular and graphical explanation. Compared to the Pretoria Group sandstones, the Daspoort Formation has similarities when plotting mineral constituents. Low Na₂O/K₂O ratios infer a more dominant arkosic sandstone nature above lithic variants within the Pretoria Group sandstones (Pettijohn et al., 1972). Mature quartz arenites generally display no Na₂O, but the Daspoort Formation sandstones' do have some minor amounts of Na₂O present (see Table 5).

2.6 Microbial mat features in clastic sedimentary rocks

The features were encountered in only a few places throughout the study of the Daspoort rocks. As this is a fairly new science, not much is known about it, especially in South Africa, bar the Magaliesberg Formation and in the Barberton rocks, the former bordering the Daspoort Formation in some areas where the Silvertown Formation is absent in the Pretoria Group succession. These features should not be confused with abiotic structures such as mudcracks. Inferred microbial mat features are generally found in both sandstones and mudrocks, but in this case it is found in the Daspoort sandstones.

In Schieber et al. (2006), microbial mats are described to be similar to ‘larger biofilms’ (Costerton and Stoodley, 2003). Biofilms are often embedded in extracellular polymeric substances (EPS) and are associated with all metabolic processes that occurred on earth (Krumbein et al., 2003). Modern substrates of biofilms include rock surfaces, deep cracks and fissures, soils and sedimentary granular systems of lacustrine, river and marine environments (Schieber et al., 2006). Schieber (2006) further states that biofilms are ubiquitous and form leathery microbial mats if natural ecological conditions, supporting their nutritional and light requirements, prevail. A good example is cyanobacteria due to their great variability, with anoxygenic phototrophs, chemotrophs, respiration and fermentation, being able to preserve traces in sediments (Schieber, 2006). These findings in siliciclastic sediments are significant in the study of the sedimentary Precambrian earth. Microbial mat features will be discussed here due to their unfamiliarity to many readers, rather than with the facies assemblages, although they have been associated with shallow water and tidal environments and even lacustrine and river deposits (Schieber, 2006).

The clastic sedimentary mat features encountered resemble those named as “old elephant skin” (Figure 2.27), sand-filled cracks, non-radial gas or fluid escape structures (‘gas domes’) (Figure 2.28), petee ridges and *Kinneyia* structures. The last two structures will be discussed here while more information about the others is available in Schieber et al. (2007).

2.6.1 *Kinneyia* Structures (according to Schieber et al., 2007)

These have typical troughs and long winding flat-topped crests which can interlink and the feature resembles a honeycomb –like pattern. The regular pits and depressions are elongate and sinuous to gently curved or subrounded. *Kinneyia* structures commonly occur on upper surfaces of sandy event beds, below fine-grained sericitic layers which may represent former microbial mat layers previously growing on the new sediment surface. It is believed that these structures form beneath microbial mats when gas is trapped between the bounding surfaces (Figure 2.28).



Figure 2.27: Elephant skin texture on a thin bedding surface near Nkwe.



Figure 2.28: A mat-related structure found on a bedding surface at Nkwe. The flap tops of the circular features are reminiscent of weathering. This could be remnants of trace fossils or 'foam marks' as referred to by Porada et al., 2007. Pflüger (1999) suggested that wrinkle structures (*Kinneyia* in this case) formed underneath microbial mats as a result of gases developing from buried, decaying mats. These structures were also referred to as moving-foam marks (Allen, 1966; Wunderlich, 1970) and small-scale interference ripples (e.g. Shrock, 1948; Mckee, 1954; Kummel and Teichert, 1970).

In this case *Kinneyia* structures would be categorised as ‘subsurface structures’ developed on flat sandy surfaces underneath mats (Figure 2.35, see also chapter 6(a)). Common features include the accumulation of sericitic material in the depressions. Associated sedimentary structures include shrinkage cracks, biolaminites, mud chips, sand clasts and fluvial/tidal channels. A suggested palaeoenvironment which often preserves these features is peritidal coastal plains (Eriksson et al., 2007 in Schieber et al., 2007). Bottjer and Hagadorn (2007) suggest an intertidal to shallow marine palaeoenvironment for *kinneyia* structures. Mata (et al. 2009) suggests that wrinkle structures, of which microbial mat related features is associated with, have 1 of 2 main geneses – storm dominated subtidal environments or the intertidal/peritidal zone. Wrinkle structures formed during initial microbial mat growth (Bottjer and Hagadorn, 2007) or during liquefaction of a microbial mat during burial (Noffke et al., 2002). Mata and Bottjer (2009) discuss excellent examples of wrinkle structures, should the reader want to study these in depth.

The structures encountered on the Nkwe sandstones are believed to be *Kinneyia* structures (Figure 2.29 and Figure 2.30). No *in situ* remnants of any lithic fragments are present. All voids have smooth edges and are in medium grained sandstones. The massive host quartzitic sandstones here represent a high energy palaeo-environment. No muddy substrates are common in the area, neither any signs of possible life during Daspoort times except for a few microbial mat features.

The oldest fossils found on earth are c.3.49- and 3.46-billion-year-old filamentous and coccoidal microbial remains in rocks of the Barberton greenstone belt in South Africa and the Pilbara Craton in Australia (Altermann et al., 2003). Between 4.5 and 3.5 Ga, earliest life possibly derived from self-reproducing RNA molecules (Forterre et al., 1992). By 2.1 Ga (~Palaeo-Proterozoic Daspoort age) ‘complex’ cells had developed, called eucaryotes (Knoll et al., 2006).



Figure 2.29: Possibly biotic (mat-related?) subrounded voids in hard quartzite. No *in situ* clays, pellets nor signs of other biological activity were seen. This mat-related feature is similar to Mata and Bottjer's (2009) description of wrinkle structures.



Figure 2.30: Close-up view of abovementioned. Note the different orders (layers) of this strange texture. This feature is similar to *Kinneyia* structures found in Namibia.

In addition to the abovementioned structures, trace fossils have been observed on the eastern part of the central Daspoort Formation near Nkwe, Swavelpoort and Hans Strydom (Figure 2.31 and Figure 2.32). The trace fossils occur on flat upper surfaces of fine grained quartzitic sandstones displaying an upward coarsening texture. Two sets of lamination are prominent; horizontal planar lamination and planar cross lamination. The trace fossils have random hollow depressions, 2-4 cm diameter, with a sandy substrate connected to it, forming a 'tail' or 'spoor'. Other elongated shapes, positive and negative surfaces, are seen in close proximity with similar composition as the host rocks. These shapes are 1cm wide and can reach lengths of 20cm.



Figure 2.31: Circular imprints with tail-like features connected leaving a sandy 'spoor'.



Figure 2.32: An elongated imprint with scattered circular depressions, similar to previous image. Towards the right a positive structure is seen with similar composition as the surrounding sandstone.



Figure 2.33: The 2.1 billion year old Gabon fossils. Photo taken by El Albani (2010). Scale bar, 1.5cm.

Relics of some of the first stirrings of modern life may have been uncovered. Scientists report in the journal *Nature* the discovery of centimetre-sized fossils they suggest are the earliest known examples of multicellular life. The specimens, from Gabon, are 2.1 billion years old - 200 million years older than for any previous claim. Abderrazak El Albani (El Albani et al., 2010) and colleagues describe the fossils' distinctive appearance as resembling irregularly shaped "wrinkly cookies" (Figure 2.33). The step from single-celled to multicellular organisation was a key step in the evolution of life on Earth and set the scene for the eventual emergence of all complex organisms, including animals and plants.

2.6.2 Petee ridges/filled sand cracks (according to Schieber et al., 2007)

These are described as positive ridges on upper bed surfaces which have cross-cutting patterns (including 'triple junctions') and form an incipient network. Sand cracks differ from petee ridges with the latter generally comprising ridges of sandstone from the lower bed, and which were related to disturbance of laminated sands in the lower bed and are separated by concave-upward segments between the ridges. Sand cracks also have a significant difference in sandstone composition/type between the crack-fill (=ridge) and that in the bed within which the cracks formed; also, unlike petees, there is no observable deformation of the upper few

sandstone laminae within the cracked bed. Some flattening of these sandstone ridges can be observed. Patterns commonly have multiple orders of ridges, up to three orders being recorded in some instances. The sand/sandstone making up the petee ridges should be the same material as that comprising the bed immediately beneath the mat/previous mat. If these features (last sentence) are not observed, it is likely that the observed structures are filled sand cracks and not proper petees. Tidal channel-fills, ripples, sand cracks and destructive wrinkle marks are commonly observed as associated sedimentary structures. It is believed that petee ridges commonly form in a braid–deltaic–tidally controlled epeiric marine coastline or intertidal environments.

The microbial structure seen in Figure 2.26 and Figure 2.35 is similar to petee ridges, but has a negative weathering feature instead of positive. Schieber et al., 2006 doesn't refer to a mat structure of this nature, though the genetic environment may overlap with other mat features. The composition and texture is different to previously encountered mat structures. The dark material is rich in Fe and boron is found in the microscopically sized needles, most notably the green tourmaline variant elbaite. There are 5 main sources of tourmaline in sediments – granitic, pegmatitic, metamorphic injected, sedimentary authigenic and reworked sedimentary detrital (Krynine, 1946). This mineral is a good genesis indicator due to its high abrasion coefficient (850-950) compared to 245 for quartz and 150 for orthoclase (Krynine, 1946).



Figure 2.34: Dark microbial mat structure with pen indicating current flow direction.

Petee ridges, rather than sand cracks were found in the East of the basin at Suikerboschfontein. Three phases were identified (Figure 2.36), some of smaller scale, but resembling the same composition and visual features. Three point polygonal intersections were common (Figure 2.36). Here the weathering structures stand out positively, dominating the rock record.

Schieber (2004) built a model that portrays the evolution of microbial mat related structures in shallow water conditions. Similar sedimentary structures found in the Daspoort Formation's siliciclastic sandstones are also related to Schieber's postulated model describing the processes which led to the features found in this study area (Figure 2.35). He envisaged mainly 5 processes for mat evolution (Figure 2.35):

1. **Mat growth** (interrupted, binding properties)
 - Includes ripples, surface binding, domal build-up, elephant skin, wrinkle structures, petee structures, bedding surface with polygonal petee ridges
2. **Metabolism** (mineral precipitation)
3. **Destruction** (dehydration, erosion, transport)
 - Includes shrinkage, petee structures, ripple patches, roll-up structures
4. **Decay** (gas development)
 - Includes gas domes, kinneyia structures (gas bubbles trapped beneath mat)
5. **Diagenesis** (organic matter destruction, mineral precipitation)

Two different phases of mat growth is identified in the Daspoort sandstones, using Schieber (2004); mat growth and mat decay-related structures (font highlighted in yellow indicate structures found in Daspoort Formation). The eastern Daspoort Formation yielded the most pronounced MRS on the upper bedding plane of the outcrop photographed (Figure 2.36 and Figure 2.37). The petee ridges are seen on a thin flat surface. It seems that there are up to three orders of these structures on a single outcrop. These orders are separated by very thin fine grained mixture of predominantly mudstone and to a lesser extent, coarse sandstone grains. A vertical slice through the unit indicates various compositions of sandstone and to the upper bed, a muddy substrate on which the adhesive MRS is exposed. The mat is bounded together by junctions comprised of medium sized sand grains. This is related to mat growth. Another example nearby shows smooth positive 'worm-like' adhesive material composed of mudstone with interstitial sandstone on the erosion surface (Figure 2.38). Triple junctions in both examples are common (Figure 2.37). Gas domes were also found in the western part of the basin. These were poorly preserved and could be related to mat decay processes where gas escapes from the mat-related structures on bedding planes.

Unfortunately the Proterozoic Bushveld igneous event and subsequent metamorphism destroyed much of the believed biotic activity found in the upper Pretoria Group's siliciclastic environmental deposits (Daspoort and Magaliesberg Formations).

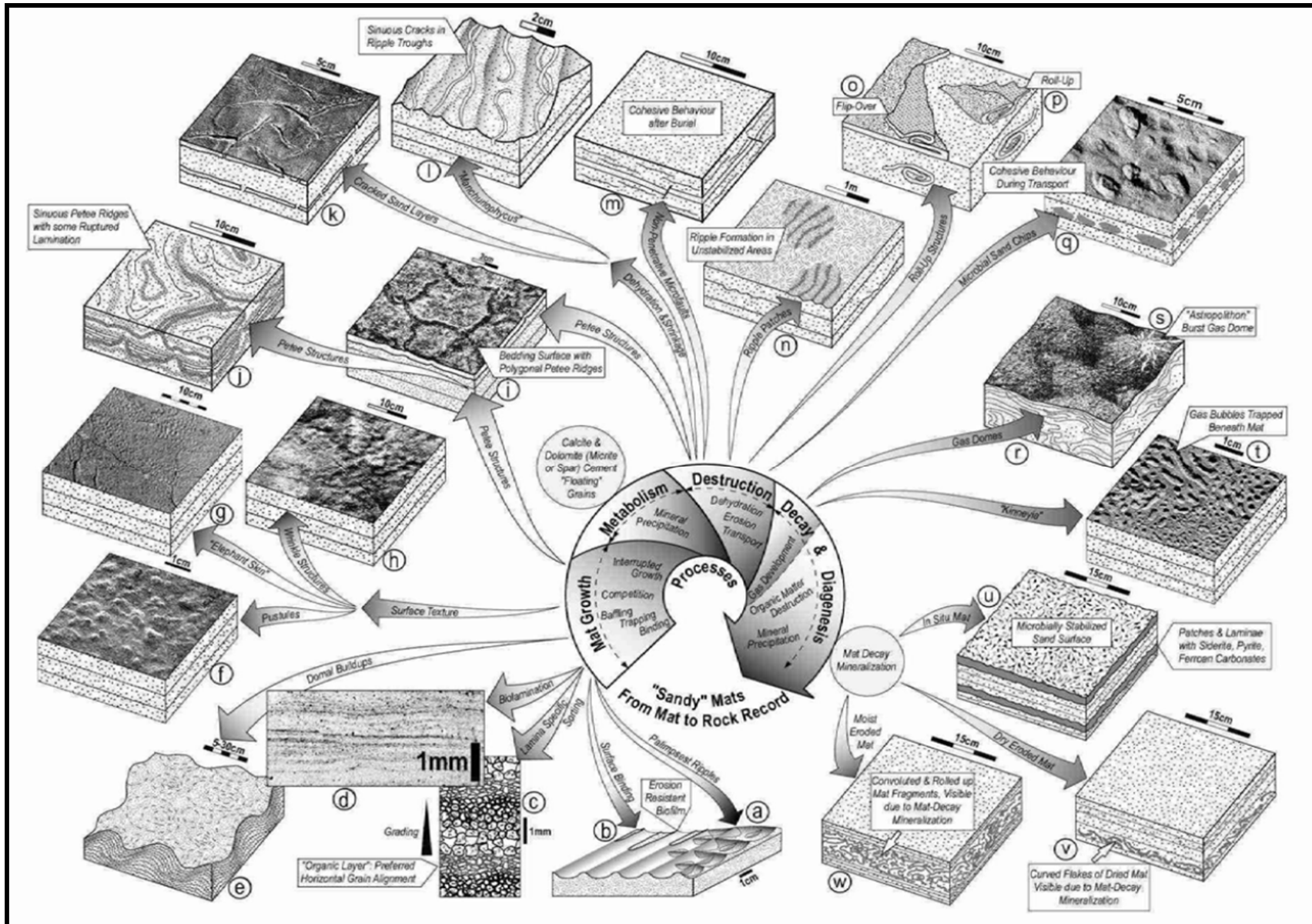

Figure 2.35: Features found in sandstones where microbial mats flourished in the past: Genetic processes are arranged clockwise along a continuum from active growth of mats to final destruction during diagenesis. Modified after Schieber (2004; his figure 7.9-1).



Figure 2.36: Suspected microbial mat features near Carolina. Note the 3 orders of petees, with the lower bed containing the best preserved adhesive sand features at the top of the photo, with the last bed represented by the slightly muddy brown triangle left of the compass.



Figure 2.37: The 1cm thick mat feature underlain by coarse arkosic sandstone with arenite displaying the grey lithology at the bottom.



Figure 2.38: Petee ridges, but here the host rock material is muddier than above. Also near Carolina.



Figure 2.39: Petee ridges close-up. Note the erratic pattern compared to the smooth curves of the other outcrop, located barely 500 m apart.

CHAPTER 3: LITHOFACIES

The distribution and interpreted relationships of acquired lithofacies information from Daspoort Formation outcrops across the basin are limited to terrain accessibility and lithological constraints. It must be stressed that there are no obvious basin-wide vertical facies relationships. Outcrops of Daspoort Formation found don't always reflect the true complete succession. Therefore lateral facies trends are limited to outcrop availability and these observations are given in broad terms.

3.1 Petrography

The Daspoort Formation consists mainly of different sandstones (and recrystallised quartzites) with secondary facies such as ironstones and mudstones. Therefore a quick overview of the sandstone facies assemblage is necessary to grasp the fundamental composition of the Daspoort Formation.

Sandstones can generally be grouped into 4 classes (e.g., Pettijohn, 1954, Figure 3.1):

- Graywackes – no chemical cement, high detrital matrix content
- Arkosic sandstones – considerable feldspar
- Lithic Arenites – more particles than feldspar, no detrital matrix, mineral cement
- Orthoquartzites - >90% quartz, derived from lithic arenites or from arkosic sandstones

Void-filler (matrix or cement)		Detrital matrix > 15% < 75%	Detrital matrix absent or scarce - <15% Voids empty or filled with precipitated cements		
		GRAYWACKES Feldspathic graywacke	ARKOSIC SANDSTONES Arkose	Subarkose or Feldspathic quartzite	ORTHOQUARTZITES chert <5%
Rock fragments > feldspar		Lithic graywacke	LITHIC SANDSTONES Subgraywacke Protoquartzite		ORTHOQUARTZITES detrital >5%
Sand or framework fraction Quartz + chert content		Variable; generally <75%	<75%	>75% <95%	>95%

Figure 3.1: Sandstone classification according to composition, matrix content and minerals present. Modified after Pettijohn (1954).

Sandstone definitions from Dott (1964) and Boggs (2006) can also be applied to the Daspoort Formation petrology, and these will be used in this thesis:

Quartz Arenites are sandstones that contain more than 90% of siliceous grains. Grains can include quartz or chert rock fragments. Quartz arenites are texturally mature to super-mature sandstones.

Feldspathic Arenites are sandstones that contain less than 90% quartz, and more feldspar than unstable lithic fragments, and minor accessory minerals. Feldspathic sandstones are commonly immature or sub-mature.

Lithic Arenites are characterized by generally high content of unstable lithic fragments. Examples include volcanic and metamorphic clasts, though stable clasts such as chert are common in lithic arenites. This type of rock contains less than 90% quartz grains and more unstable rock fragments than feldspars. They are commonly immature to sub-mature texturally.

Wacke describes sandstones that contain more than 15% clay matrix in between framework grains.

Quartz Wackes are uncommon because quartz arenites are mostly texturally mature to super-mature.

Feldspathic Wackes are feldspathic sandstones that contain a clay-rich matrix that is greater than 15%.

Lithic Wacke is sandstone rich in lithic fragments that also has a matrix greater than 15%.

Arkose sandstones have more than 25 percent feldspar. The grains tend to be poorly rounded and less well sorted than those of pure quartz sandstones.

Conglomerates are coarse grained siliclastic rocks with a muddy or sandy matrix.

A general petrographical classification of the facies assemblage for the Daspoort Formation sandstones is depicted in Figure 3.1. It is evident that the bulk of the sandstones sampled and analysed microscopically are quartz arenites (Figure 3.2) with arkoses, lithic arenites and quartz wackes completing the bulk composition for Daspoort Formation sandstones. Apart from the sandstones, quartzites, mudrocks and ironstones are present in the basin.

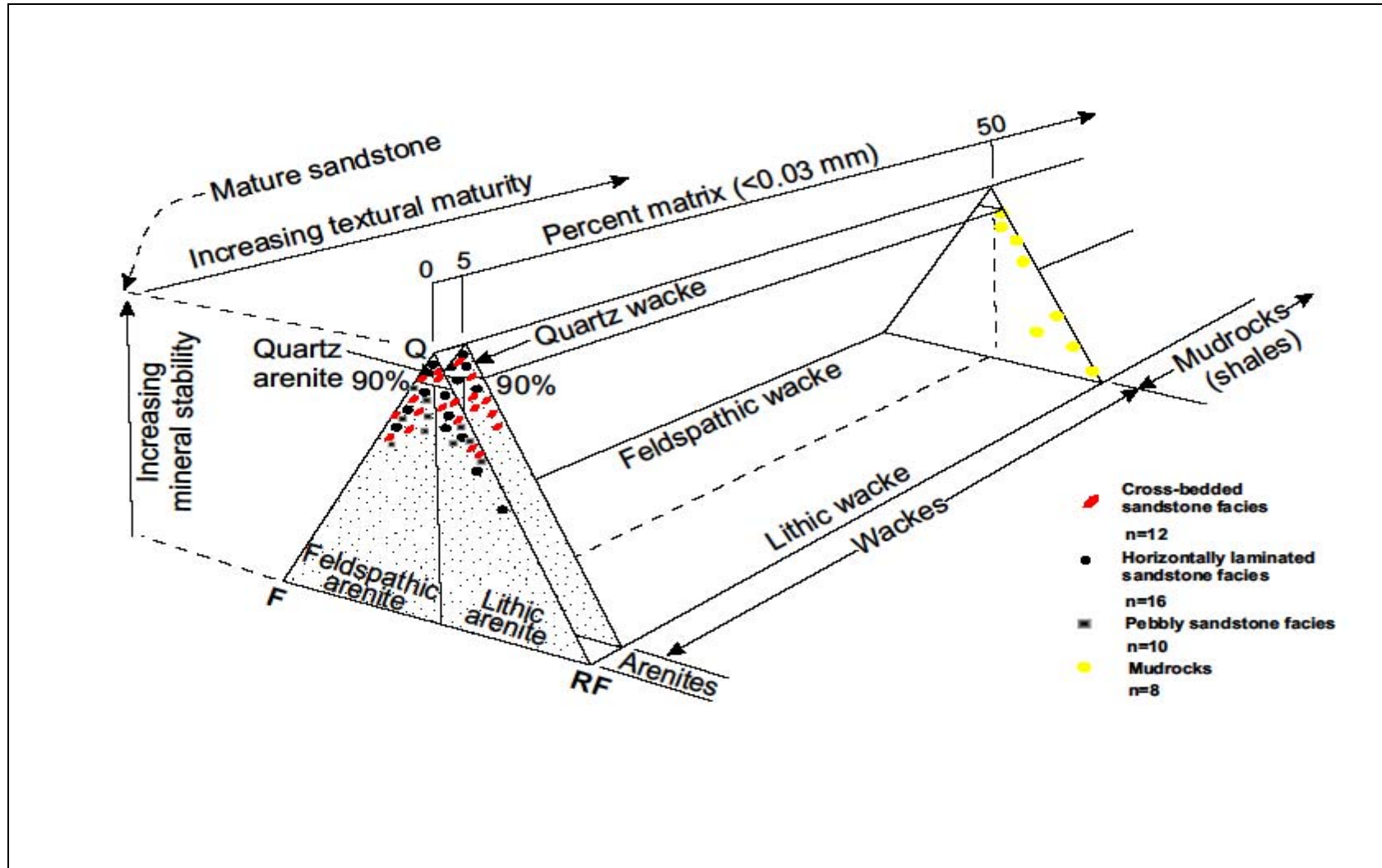

Figure 3.2: Sandstone classification after Dott (1964) and Boggs (2006). Note that the three major sandstone facies assemblages are concentrated towards the quartz arenite corner while the mudrock assemblage tends to lean more towards the lithic wacke and mudrock compositional regions. See text for sub-facies discussions. F = feldspars; RF = rock fragments, lithic grains, unstable; Q = quartz, chert, quartzite fragments. Points within the triangles are representative of relative proportions of Q, F and RF end members.

3.2 Sandstone maturity

Pettijohn (1954) has expressed relevant classification techniques to establish the maturity of sandstones. He explains that maturity can be equated essentially with chemical and mineralogical compositions. Chemical associations can help describe the compositional maturity of sandstone (Pettijohn, 1954). Following this, it is envisaged that maturity is best portrayed by the following parameters (with maturity type in brackets), which are also good indicators of provenance and fluidity (the capacity to accommodate variable degrees of smoothness).

- Quartz to rock fragment and to feldspar ratios (compositional)
- Grain size (textural)
- Sorting (textural)
- Rounding (textural)

Facies assemblages (with sub-facies bulleted) identified in the Daspoort Formation are:

1. **Pebbly sandstone (arkosic to lithic arenite)**
 - **Conglomerates**
2. **Mudrock**
 - **Fe-rich sandstone**
3. **Cross-bedded sandstone**
 - **Trough cross-bedded sandstone**
 - **Planar cross-bedded sandstone**
4. **Horizontal laminated sandstone**
 - **Massive sandstone**

Immature sandstones generally have high Al, Na and K contents (Pettijohn, 1972). The Daspoort Formation sandstones analysed have contradictory values compared to the above-mentioned elements, bar aluminium oxides. The Al content can be ascribed to the mudrocks and associated authigenic clays in the Daspoort Formation. The generally immature localisation of Daspoort Formation sandstones occurs in the eastern part of the preserved basin where interlayered mudrocks prevail, consisting of weathered feldspars and micas. Other areas with common clays in the sandstone matrix are seen through the wackes in the central basin and patches in the western areas (Figure 3.3). It is believed, age, diagenesis and weathering features apart, that the Daspoort Formation sandstones indicate generally more mature rather than immature compositions in the unit as a whole.

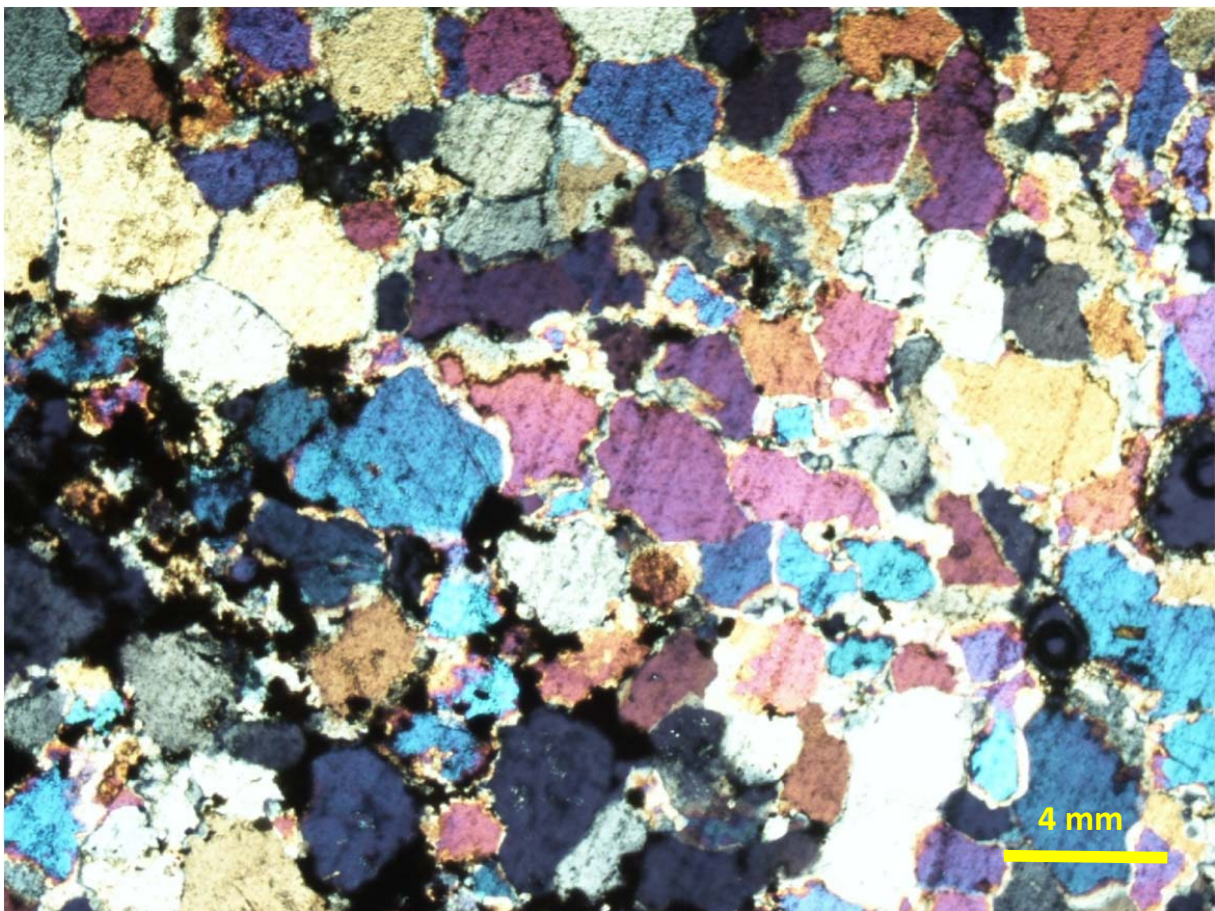

Figure 3.3: Typical thin section of Daspoort sandstone. Note generally equant grain shapes, good sorting, medium rounding (with overgrowths) and minor interstitial matrix minerals between dominant, bigger quartz grains. Microscopic view: Crossed polarised light. Thin section made exceeds normal thin section thickness.

3.3 Pebbly sandstone facies assemblage (arkose to lithic arenite facies)

This lithofacies assemblage can reach a thickness of up to 2 m. This is observed in the western region of the basin, in particular at the Hekpoort and Mothlabeng sites where it is observed twice in the Daspoort's vertical profile. The thinnest unit of pebbly sandstones has a thickness of less than 40 cm. The Daspoort lithologies in the basin east of Pretoria don't have any pebbles in their matrix. The pebbly sandstones' external geometry varies from each outcrop, individual locality being the distinguishing parameter rather than any regional trends across the basin.

Grain sizes of the matrix vary from very coarse in the far west to medium-coarse in the central parts of the basin where bimodal grain sizes are noted, which vary from 0.5 mm up to 4 mm. Sorting is good in the mature sandstones of the Pretoria region, but changes to moderate-poorly sorted arkoses in the far west (Figure 3.4). The pebbles mostly have ellipsoidal shapes whose diameter varies from a couple of millimetres to 2 cm (Figure 3.4). Only one occurrence of subrounded to angular pebbles is observed, notably close to a shear zone, near the Silverton Formation contact. The well rounded pebble-bearing rock units are usually found at the lower to middle part of the Daspoort Formation's upper unit. They are occasionally stretched, parallel with the bedding.



Figure 3.4: Pebbly sandstone from Mothlabeng, western Daspoort basin. Note the bimodal grain sizes.

The composition of the matrix and pebbles is similar but of different maturity, the pebbles being either recrystallised quartz or chert whereas the matrix is predominantly quartz-rich arenite to arkose. Medium grained quartzites as well as mature sandy lithologies are associated with recrystallised silica grains and a lesser amount of chert grains which are generally moderately sorted.

The lithologies west of Pretoria are gently dipping, and generally more exposed to weathering. This results in an orange-brown colour of the coarse sandstones. Pebbles are susceptible to weathering and often leave voids on the surface of the bedding planes where they are removed. The pebbles are generally widely spaced and randomly scattered (Figure 3.5). Isolated occurrences of a preferred orientation of the pebbles, similar to imbrications structures, are noted in the Pretoria region. The flat sides of the pebbles commonly display an upstream dip. Minor occurrences of upward fining successions have been noted which is a subordinate character to the above-mentioned properties. Horizontal lamination rarely bends around the pebbles, but the laminae are mostly not deformed by the presence of pebbles, therefore the thin bedded laminae are a pre-deformational texture.

The pebbly lithologies have irregular contacts with bonding surfaces on either side. It is overlain by Fe-rich sandstone in the central and eastern parts of the basin. The pebbly units are laterally discontinuous due to its location in the upper unit of the Daspoort Formation, where they are susceptible to post-Proterozoic destruction forces (weathering, tectonics etc.) These lithologies are associated with ripple marks, channel fills, form sole marks and imbrications on the lower bounding surface. Ripples are medium sized (wave amplitude of 3.5 cm; wave length 18 cm) compared to the big wave ripples at Kaalbooi. It appears that this lithofacies is associated with asymmetrical wave ripples in the central Pretoria basin.

3.3.1 Conglomerates (sub-facies assemblage of Pebbly sandstones)

This is a very localised and isolated set of lithofacies. Conglomerates are found in the upper unit in the Faerie Glen area in the central basin, in another isolated location in the south-east whereas the largest accumulation of these is found in the western basin. Most of these conglomeratic lithologies occur near the base of a unit, where rock bodies are also bounded by erosion surfaces. The conglomerate units range in thickness from 20cm to 2m. The diameter of pebbles varies, but can range from 0.4 cm to 6.4 cm (Figure 3.5). On the basis of the average pebble size (4-64 mm), these Daspoort conglomerates may be classified as pebble conglomerates, resembling an arenitic nature (Figure 3.6) due to its pure fine to medium grained white sand grains. These are well sorted.

Looking at Figure 3.5 the central basin conglomerates, which have bigger pebbles, would be classed as a sandy conglomerate whereas the western basin conglomerates contain more clay in the matrix, and may fittingly be called pebbly wackes. The pebbles in these wackes are considerably smaller compared to the Faerie Glen conglomerates. Pebbles are widely spaced within the matrix. These conglomerates are matrix supported, with an upward coarsening vertical arrangement in the unit's succession. The pebbles in the conglomerates are randomly scattered and have identical compositions as observed in the field. There are no rims seen around the pebbles, but the material of the pebble is similar to the matrix which could indicate that the pebble is derived from an eroded clast. The binding matrix, in this case, more of a fine muddy substrate (wacke related) than a mat-related material, enabled the pebble formation and is preserved through local post deposition. This lithofacies assemblage dip and dip direction concur with the bounding lithological units in the Daspoort Formation. The conglomerates are seen as banana shaped troughs of various sizes wedged in between coarse grained sandy units, especially in the western basin where channel fills predominate in outcrops. Features found in this sub-facies assemblage include wave ripples and erosional bedding surfaces. Undulating patterns of these surfaces are well developed in the city of Pretoria. Erosion of the bedding planes by pebbles is absent or negligible.

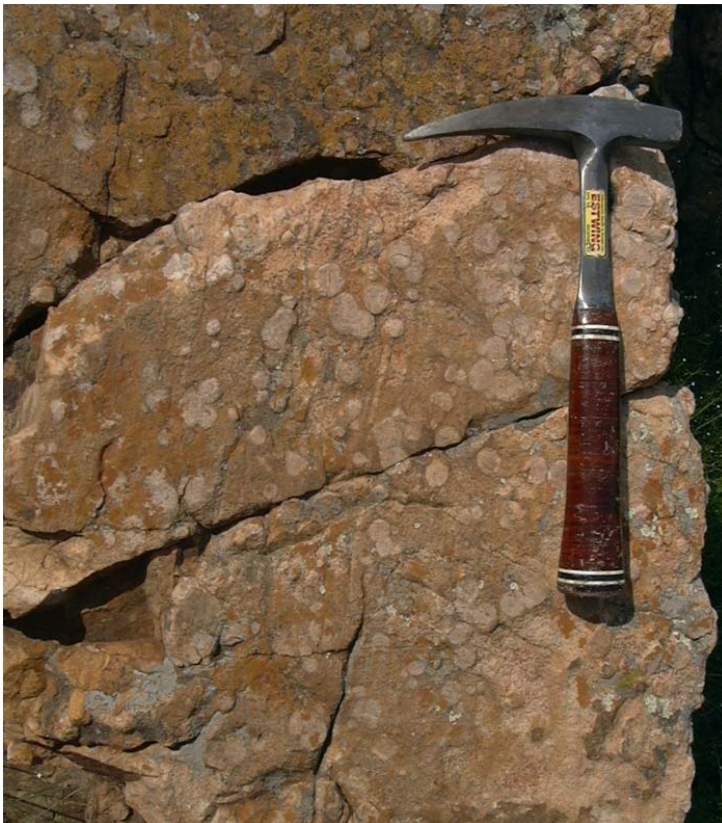

Figure 3.5: Conglomerate in Faerie Glen.



Figure 3.6: Conglomerate classification after Nelson (2000).

Conglomerates are also classified by the dominant clast size (according to Nelson, 2000).

- Granule conglomerate 2–4 mm
- Pebble conglomerate 4–64 mm
- Cobble conglomerate 64–256 mm
- Boulder conglomerate >256 mm

3.4 Mudrock facies assemblage

The Daspoort mudrocks are relatively soft, dark brown units which rarely exceed a thickness of 1 m and can be less than 1 cm thick. Due to the fine texture of the mudrock and its interbedded nature with sandstones, the grains are very small and well sorted compared to the sandstones of the Daspoort Formation. Mudrocks are the most mature lithology in the Daspoort Formation. There is no specific geometry or shape that these mudrocks display, but are predominantly seen as interlaminated with sandy units, 'mats' draping irregular surfaces of other lithologies or purely massive fine units. They display a similar upward coarsening trend as seen throughout the Daspoort sandstones. The thinnest visible mudrock laminations are similar to varved mudstone, usually found in the Vryheid Formation, above the Dwyka Formation tillites in the Phanerozoic Karoo basin. Mudrocks commonly alternate with thin laminated sandstone or even siltstone. This is especially evident at the base of the Daspoort Formation where it overlies the Strubenkop Formation shale. Towards the west of Pretoria mudrock

becomes less evident. Outside Koster, further to the west, finely laminated mudstone occurs in horizontal bands within predominant sandstones. Mudrocks occur mainly in the eastern basin and alternate with Fe-rich sandstones towards the north-eastern regions of the preserved Daspoort Formation. Mudrocks predominate at exposed Strubenkop / Daspoort Formation contacts (Figure 3.7) where the bottom unit of the Daspoort Formation displays laminations of sandstone and mud forming a gradational contact with underlying mudstones of the Strubenkop Formation. Mudrocks are not well correlated in the Daspoort Formation due to its discontinuous nature. Previous workers did, however, make positive correlations of this facies assemblage in the north-eastern Daspoort Formation. No laboratory analyses were done on mudrocks; therefore the composition of this lithofacies assemblage is based on field observations. Its reddish-brown colour indicates oxidation of Fe-rich constituents on the weathering surface. Freshly exposed planes are structureless and have a lighter colour. Mudrocks are also associated with brecciated massive sandstones in the region west of Pretoria. Occurrences of mudrock lenses are limited. Mudcracks are observed in the eastern basin on weathering and previously cohesive surfaces on the upper unit of the Daspoort Formation, near the Silverton Formation contact. These cracks are predominantly filled by a fine clayish matrix, binding the surface mat related feature which has a muddy substrate (Figure 3.8). Various weathering features such as snuffbox weathering is observed, where muddy substrates fill joints and an oxygen reducing environment, emphasizing Fe-rich features in this lithofacies assemblage, is prominent.



Figure 3.7: The lower Daspoort Formation in Pretoria consists of parallel laminated sandstone alternating with mudrocks, which become predominant towards the underlying mudstones of the Strubenkop Formation. Person for scale.



Figure 3.8: Mudcracks binding the weathering surface at Suikerboschfontein, Mpumalanga.



Figure 3.9: Iron-rich cement cutting through the bedding of the Fe-rich sandstones of the eastern Daspoort Formation. This is similar to Liesegang rings, except for the angular features.

3.4.1 Fe-rich sandstones (sub-facies assemblage of Mudrocks)

Thin layers (2 mm to 3 cm) of Fe-rich sandstones alternating with veneers of oxidised mudrocks are found throughout the basin, usually at bedding contacts or they can be found often forming the top layer on outcrops. The thicker units reach a maximum of 2 m. This lithofacies assemblage is common throughout the Daspoort Formation, although not occurring in abundance. Grain shapes change from subrounded in the east to sharp, angular dispersed granules towards the west. This trend is also true for grain size, with small grains being associated with the subrounded shape. Bimodal grain shapes and sizes are found near Mothlabeng near the Botswana border in the far west of the preserved basin. These vary from fine to coarse grained. Medium sized grains are the most common for this lithofacies assemblage. Sorting is poor due to the variety of grains and minerals present in the matrix. Minerals found in Fe-rich sandstones include feldspar, limonite (and other subordinate oxides), quartz and minor amounts of mica. Reddish oxidation colours of pyritic cubes in the Fe-rich sandstones are common. Speckled oxidation-reduction spots are seen with red to brown halos engulfing them, especially near the Silverton Formation contact. Orange-brown coloured rocks are associated with spotted iron-related secondary weathering. Iron bands are also observed locally in the east of the basin. They alternate with dark horizontally laminated quartzites.

Due to the thin nature of these units, no vertical trends, such as upward fining / coarsening can be identified. These Fe-rich sandstones are often seen as weathering surfaces or draping underlying lithologies; thus blanketing these units and copying their geometry. These lithologies share the mudstones' in the eastern part of the Daspoort basin where it is locally correlative, but sporadic elsewhere. Weathering of the Fe-rich sandstones differs locally. In the eastern part of the basin a dark coloured cement, consisting probably primarily of iron and manganese, is found cross-cutting the bedding. This cement precipitated as fluids in joints and further developed through the unit. This is similar to Liesegang leaching, but the characteristic circular rings are absent (Figure 3.9). Fe-rich sandstones are also associated with brecciated massive sandstones in the region west of Pretoria and isolated outcrops in the Pretoria area (i.e. Faerie Glen). Limited occurrences of cross-bedding are also noted. Ripple marks are the most abundant in this facies (Figure 3.10). Angular flute casts (which might reflect movement of coarse, angular grains across unconsolidated sands) and associated sole marks are found on bedding planes in the western parts of the Pretoria basin (Figure 3.11). Negative weathering features are common throughout the Daspoort Formation. These features expose the underlying lithologies (Figure 3.12). Fe-rich sandstone lenses with an interstitial mudstone matrix are also common, especially in the Mpumalanga (south-eastern basin) area; most prominently associated with arkosic units (Figure 3.12).



Figure 3.10: Large scale (provide scale) asymmetrical ripples on a Fe-rich sandstone near Machadodorp in the south-eastern region of the basin. Stone wall for scale. Insert indicates the ripple marks on a smaller scale.

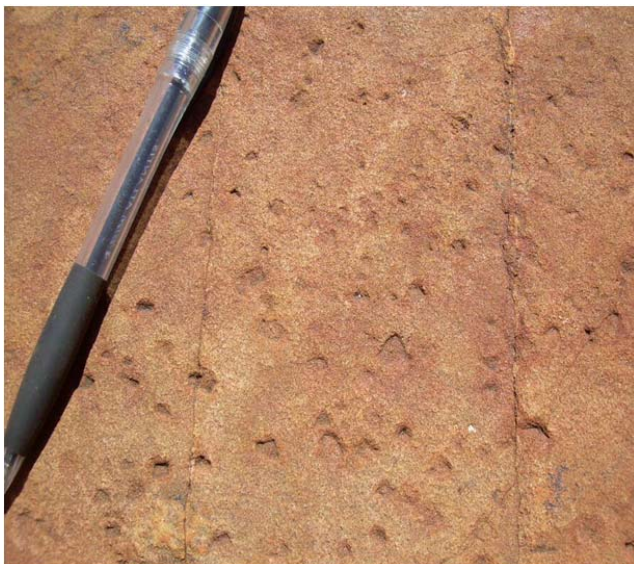

Figure 3.11: Load marks with angular troughs directed away from the observer. This is indicative of the transport direction. The casts are remnants of cubic Halite mineralization.



Figure 3.12: A mudrock layer on sandstone with compressed sand grains scattered in the muddy matrix. Underlying this layer is arkosic sandstone from the central Pretoria area. These layers often resemble a weathering surface. Negative weathering features are common in this layer which usually appears in the upper Daspoort sandstone units.

3.5 Cross-bedded sandstone facies assemblage

3.5.1 Trough cross-bedded sandstone sub-facies assemblage

Trough cross-bedding of various dimensions is common throughout the basin. Size of these cross-bedded sandstone units varies from 10 cm – 4 m. Grain sizes are generally alternating between medium and coarse grained, being monotonously rounded. This trend is observed predominantly in channel fills where an upward coarsening texture is evident. Upward coarsening units are characteristic of cross-bedded sandstones in the Daspoort Formation, both trough- and planar cross-bedded. Sorting is poor and immature wackes and arkoses dominate the facies assemblage, with subordinate lithic arenites also present. Dips of the facies are generally gentle, with maximum dips of 25°. The cross-bed sets intersect at low angles (Figure 3.13). The coarse cross-bedded sandstones are found in the western part of the basin whereas they gradually fine towards the east.

There is a big variety of minerals found in these sandstones. The poor sorting accommodates minerals of various compositions. The most abundant minerals are quartz, feldspar, limonite, sericite and mica. Other oxides and unidentified deformed minerals whose texture is thwarted by metamorphic processes are also present (see Petrography in Chapter 2). The cross-bedded units are cut off by erosion surfaces, planar horizontal or units with other bedding orientations. It seems that the trough cross-bedding units and channel fills intersect each other at oblique angles in the Koster area (Figure 3.14). The lateral extent of this lithofacies assemblage is limited by these cut-off parameters, but on a bigger scale the trough bedding character is evident throughout the basin, albeit on different scales. Bigger structures are prominent in the east compared to the smaller features of the western Daspoort Formation.

Bedding thickens towards the centre of swales, or micro-scale channel-fills. These beds tend to flatten out at trough terminations, but are often intercepted by another series of trough cross-beds or even a geometrically complicated channel-fill. The Koster road cut (Figure 3.14) indicates that the geometry of trough cross-bedding appeared to be quite complex in detail. The wavy bedding surfaces of the trough cross-bed sets would seem to form bounding areas between preserved channel-fills. Channel fills are abundant, which occur concurrently with this sub-assemblage, but they are generally shallow (5 cm – 40 cm) and wide (60 cm – 4 m) when compared to the preserved trough cross strata.



Figure 3.13: Trough cross-bedding exemplified by very coarse sandstone foresets within a finer sandstone matrix. Photo taken at Koster. Pen for scale.

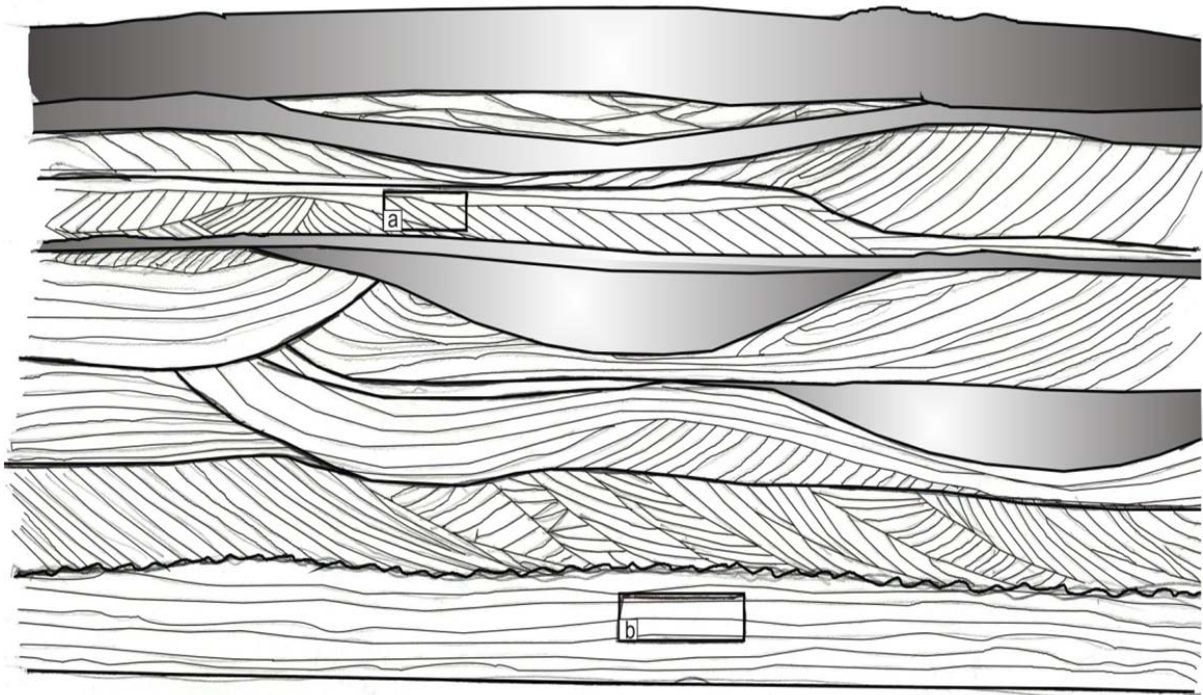

Figure 3.14: Koster area cross-section. Grey areas display massive arkosic arenites (channel-fills?). Block (a) represents trough cross bedding (Figure 3.13) while block (b) is indicative of the horizontally laminated sandstone facies in the same road cutting north of Koster.

Subordinate to both the above is herringbone cross-bedding which is found locally in the Pretoria region. Trough cross-bedding consists of curving laminations which are convex-up. Concretions (Figure 3.15) and ripple marks (Figure 3.16) are common in these sandstones, especially towards the western parts of the basin. Concretions are found sporadically scattered throughout the lithofacies assemblage with surrounding halos representing the precipitation from matrix material. The concretions do occur in different units within the same lithofacies assemblage. Both symmetrical and asymmetrical ripple marks are observed in these rocks, but the latter is more commonly associated with the coarser grained lithologies.



Figure 3.15: concretions in the Hekpoort area.



Figure 3.16: Ripple marks in the Hekpoort area.

3.5.2 Planar cross-bedded sandstone sub-facies assemblage

Its thickness ranges from a couple of centimetres up to 10 m. This thickest noted succession is observed in the southeast of the basin. An average set thickness of 50 - 80 cm is common throughout the study area. Grain sizes are usually very fine grained (and rocks are often quartzitic), but very coarse grained cross-bedded sandstone is evident near Koster. Therefore this sub-facies assemblage can be subdivided according to grain size. Planar cross-bedded sandstones in the Daspoort Formation are generally more mature than its trough cross-bedded parent facies assemblage. The former is associated with smaller grain sizes which relate to better sorting in vertical successions observed in outcrops. This facies is very prominent in the Daspoort Formation. Its main constituent is quartz arenite, but other less common lithologies occur sporadically across the basin. These include lithic arenites and quartz wackes, as also found by Eriksson et al. (1993).

Vertical upward coarsening trends are common in this lithofacies assemblage, however not as prominent as in the trough cross-bedded sandstones. The latter usually forms incised troughs or channels which cut off the planar cross-bedded sandstones at sub-horizontal angles.

These facies are associated with secondary weathering and Fe-leaching. Concretions are noted in the western parts of the Daspoort Formation. They vary in size from about 2 cm to 10 cm. Smaller concretions commonly occur in recrystallised quartzites whereas bigger concretions are contained in the more pristine facies and to a lesser extent also in the horizontally laminated sandstone assemblage.

The cross-bedded sandstone facies assemblage is widely spread across the basin, displaying heterogeneous architectural properties. Cross-bedding in the Daspoort sandstones is in fact the

most abundant sedimentary feature. Wavy bedding surfaces, probably related to a transition to upper flow regimes, occur at various scales and are relatively abundant. These appear to mark the unconformable contact between the two main units defined in the Daspoort Formation. The cross-laminated quartzites (where bedding is observed - Figure 3.17) are dark coloured and are usually between 10 cm and 50 cm thick. Grains within the cross-bedded assemblage are well sorted and fine- to medium sized. They are generally well rounded. Recrystallised quartz forms chert bands which occur sporadically between the cross-bedding, especially west of Pretoria. Finely laminated cross-bed sets have a variable composition compared to the more homogeneous nature of the medium grained lithic arenites. The coarser, brittle lithic arenite wackes tend to be darker than the finer-grained sandstone wackes.

Groove marks, load casts and sand clusters are visible on thin mudrock layers marking quartzitic sandstone surfaces (Figure 3.18). Recrystallised quartzite bands follow the planar trough bedding (Figure 3.19) pattern. Common weathering patterns of the cross-bedded sandstone facies assemblage, especially in the quartz wackes, include pothole-like negative scours, and mudcracks displaying a dark orange to brown colour of the weathered layer (Figure 3.12). This layer is prominent in the Pretoria area where muds and sands are admixed due to rapid deposition or possibly adhesive characteristics, similar to a microbial mat feature. Immediately below this layer a coarse-grained lithofacies will often occur. The grain size of the mixed layer is fine- to medium grained due to its sandy mud composition, but coarse variants are noted in the Pretoria area as well as in the western basin.



Figure 3.17: Planar cross-bedding in Pretoria associated with quartzite. Pen for scale.



Figure 3.18 (left): Planar cross-bedding (bottom) and trough cross-bedding in medium grained sandstone on the outskirts of Pretoria. Pen for scale. Figure 3.19 (Right): Recrystallised quartz bands in dark quartzite also showing cross-bedding at Faerie Glen (Pretoria East).

3.6 Horizontal laminated sandstone facies association

A variety of sandstones are associated with this facies association. Therefore thicknesses associated with this lithofacies assemblage differ considerably across the basin. Maximum thicknesses vary between 20 and 30 m (for the massive sandstone sub-facies association), although this occurrence is limited. Thicknesses subordinate to these are found in dark coloured quartzites with a maximum thickness of 3 m. All other sandstones observed containing these horizontal beds are between 3 cm and 60 cm thick. The latter is the most prominent thickness throughout the Daspoort Formation for this lithofacies assemblage. The horizontal stratification is characterised by thin veneers between 1 cm and 15 cm thick.

The upper Daspoort sandstones displaying horizontal laminae are medium- to coarse grained, brittle and have variable colours ranging from milky white to chocolate brown. The sandstones in the lower units are harder and have a chalky resemblance in some areas. The horizontal laminated sandstones have a gradual transition at the Strubenkop Formation contact from brown sandstone into shale and rarely silty shale, whose lower contact is ferruginous. Grey, brown and black colour mottles are common near the Strubenkop contact, where mudrocks are

more abundant. The top contacts of these horizontal laminated facies assemblages are commonly abrupt due to undulating non-conformities. Maturity trends are not distinguishable across the basin as upward fining as well as upward coarsening units are exposed throughout the study area. They alternate with the availability of sediment supply and accommodation space during deposition cycles. The lateral continuity is not only dependent on the outcrop availability, but the vertical incision into thin horizontal laminations and, on a bigger scale, the dominance of trough cross-bedded sandstones (where it cuts off units below) limit the regional extent of this lithofacies assemblage.

Arkoses are not common, but are mostly found near the Silverton Formation contact (Upper Daspoort sandstones). This contact is most prominent in the Pretoria area where Fe-rich sandstone occurs near the top of the Daspoort Formation. Similar Fe-enriched sandstones are found in the eastern basin. This is observed as one of the most mature facies assemblages in the Daspoort Formation. Other sandstone compositions in the upper Daspoort succession include massive quartz arenites and subordinate pebbly sandstones. There is a colour association with grain size: light coloured sandstones are coarse grained while darker rocks are often associated with recrystallised quartzites rather than sandstones, except when they are iron (Fe)-enriched. Horizontal bedding patterns do expose weathered oxide minerals with heavy element compositions of Fe, Mn and Ti (see geochemistry in Chapter 2). The major minerals in these sandstones are quartz and subordinate feldspar. Concretions are also found in this lithofacies assemblage. Chemical alteration is common in these lithologies immediately west of Pretoria, especially at Saartjiesnek.

3.6.1 Massive sandstone (sub-facies assemblage of Horizontal laminated sandstone)

The thickest horizontally bedded successions are found in massive sandstones. These massive bed sets can reach a thickness of up to 30 m. The eastern basin has the thickest outcrops where bed thicknesses range between 4 - 30 m. The central basin has thinner beds alternating with other lithofacies assemblages such as cross-bedded sandstones (including sedimentary structures such as convolute and herringbone bedding). The massive sandstone beds occur in packages of 1 - 2 m (see Paul Kruger Street vertical profiles) and can reach 6 – 10 m thicknesses in areas towards the west of Pretoria. The western basin facies assemblage is more homogenous than the central basin. Massive sandstones have an average thickness of 3 – 4 m, but can also reach 10 m (see Scheerpoort and Hekpoort vertical profiles).

The massive homogenous sandstone units across the Daspoort basin imply possible high energy 'events'. Grain size is medium-coarse with upward coarsening cycles dominant in the upper Daspoort succession. Grains are well rounded and moderately- to well sorted depending on the

individual outcrop. The external geometry of this facies assemblage has an inconsistent nature. Undulating individual bed bounding surfaces are common. Due to the homogeneity of these sandstones, high quartz content with subordinate feldspar minerals characterise the matrix. Arenites are common. The massive nature of these units is evident at bounding surfaces which are often marked by scours and incision into the units below. The upper contact is usually sharp or marked by unconformities. The eastern part of the basin does accommodate correlation of these units far better than anywhere else in the basin. The thinner units in the western part of the basin don't correlate well due to the high nature of bimodal cyclical trends which confuse lateral interpretation.

The prominent features are the fine recrystallised quartz and chert bands parallel to the bedding. Recrystallised quartz grains in dark quartzites are abundant west of Pretoria. Isolated grains often show a thin halo of the same material as the grain, around it.

Other common structures observed on bed surfaces in this facies include small scale channel fills, ripple marks, lenticular geometry of some beds, slumping, erosional contacts, flute- and load casts. The load markings and associated secondary minerals such as limonite are noted on the bedding planes of the sandstones as black or brown cubic (limonite and hematite after limonite) inclusions of various sizes ranging between 2 mm and 18 mm. Weathering features observed in these sandstones, especially quartz arenites, include 'elephant-skin' wrinkle patterns, observed east of Pretoria and near Soutpansberg Road in the city (Figure 3.24).

Coarse sandstones are interbedded with clean, hard quartzites in the east of the basin. This sedimentary architecture also occurs on a regional scale northwards and in the far west, near the Botswana border, where subordinate quartzites and fine grained lithic arenites become replaced by coarse grained arkoses and wackes. These have micas and other clay minerals in their matrix. A lateral continuation of recrystallised quartz bands is seen locally in hard, dark quartzites.

Quartzites have not been classified as a lithofacies assemblage due to its variable nature across the Daspoort basin. This rock type can be classed with massive quartzitic sandstones, irrespective of bedding or other sedimentary features found in these sandstones. Some examples of the quartzitic nature of the sandstones are evident in the Pretoria area, west (Figure 3.21) and east (Figure 3.22) of the city.



Figure 3.20: Concretions in the massive sandstone at Saartjiesnek, west of Pretoria. Halos are present.



Figure 3.21: Recrystallised horizontal quartz bands in quartzitic sandstone at Saartjiesnek. Pen for scale.



Figure 3.22: Finely horizontally laminated sandstone at Faerie Glen. Pen for scale.

3.7 Ripple marks

Most of the symmetrical ripples measured have an apparently wave generated nature, according to the Tanner (1967) fields in the ripple index (RI) measured against the ripple symmetry index (RSI) space. This is a relatively reliable parameter to determine the origin of ripple marks of sedimentary siliciclastic rocks in the field. It can be noted in (Figure 3.26) that the more current-related ripples are in the west and then there is a transition through the central part of the basin, to the east, where the ripples indicate more pervasive wave origins. The coarsest grained sandstones of the Daspoort Formation are found in the western area. While this trend can be considered the predominant ripple mark classification for the Daspoort sandstones, it should be noted that Tanner's (1967) method is not 100% accurate, and only provides an estimation of genetic conditions; the trends are more meaningful than individual measurements.

Most of the ripples observed in the field are symmetrical (Figure 3.23). Few interference ripples are noted, although the biggest ripples seen in the Daspoort Formation, near Machadodorp in the east of the basin, are asymmetrical, which suggests current ripples. Schreiber (1991) described the symmetrical ripples as having rounded, straight or slightly sinuous crests. She also did not find any evidence of swash ripple marks and only a few asymmetrical ripple marks.



Figure 3.23 (left): Symmetrical wave ripples on the eastern outskirts of Pretoria. Plant leaves approximately 3 cm long. Photo courtesy of Lo-Mari Visser. **Figure 3.24 (right):** Elephant skin weathered sand layer at the eastern outskirts of Pretoria. Pen for scale.



Figure 3.25: Asymmetrical ripples near Nkwe Ridge Observatory, east of Pretoria.

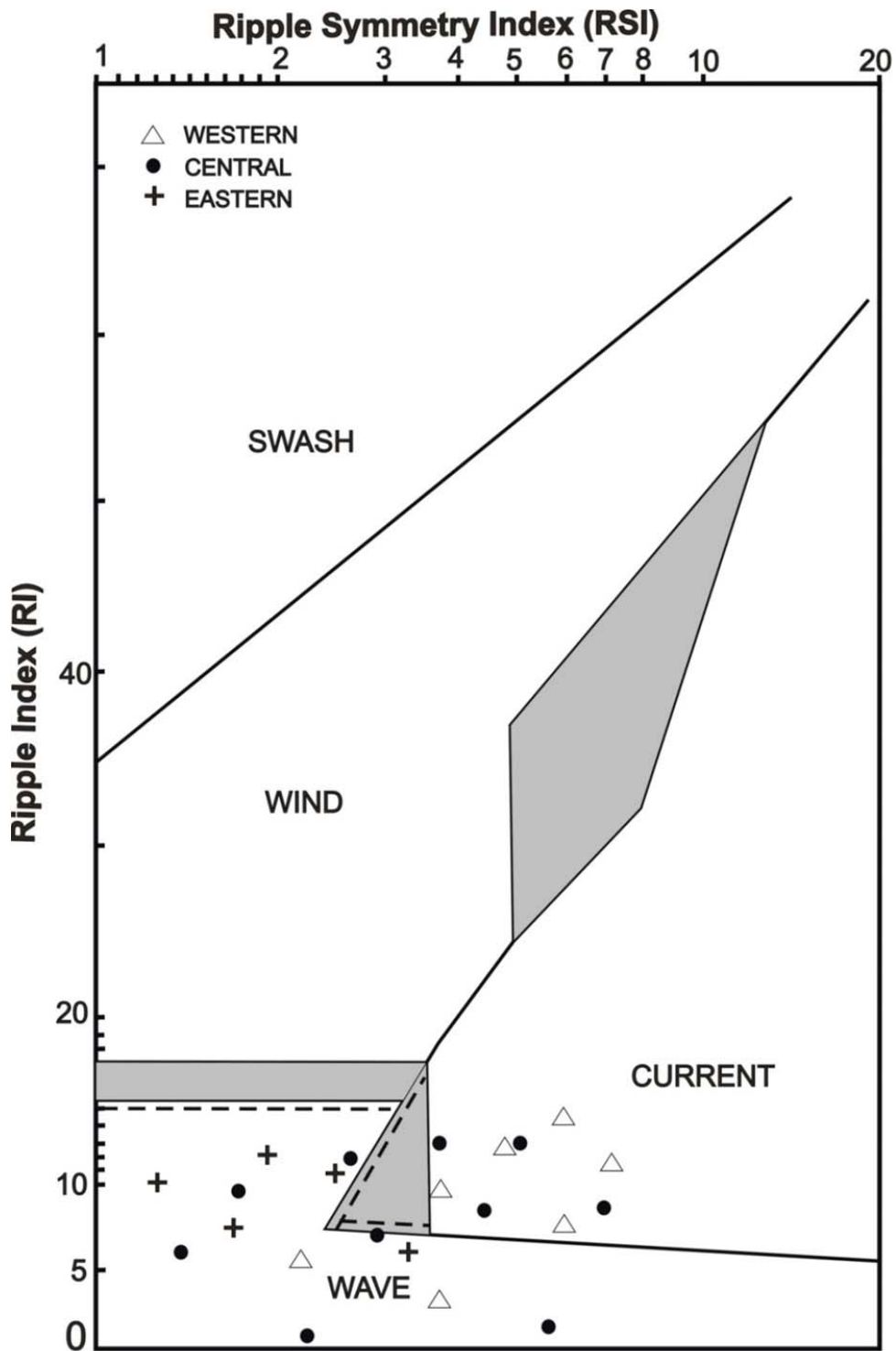

Figure 3.26: Ripple mark distribution across the Daspoort Formation, using Tanner's (1967) method to distinguish between waves, current, swash and wind generated ripple marks.

3.8 Lithofacies relationships

Various sedimentary parameters such as bed thickness, grain size, sorting and scale of sedimentary structures are commonly considered when examining regional patterns and basinal correlations in clastic sedimentary rocks (Miall, 1984). This helps to identify the cycles which may be present in the succession. Unfortunately these parameters are not in any meaningful way laterally continuous in the Daspoort Formation, therefore the sedimentary structures should be interpreted to identify so-called 'events' of deposition. Therefore, the interpretation of the study area is divided into the three areas: western, central and eastern basins. The stratigraphic successions found in each respective area have locally correlative lithofacies assemblages.

The horizontally laminated sandstone facies assemblage is generally the **thickest** throughout the basin (Table 6). The massive vertical successions in the east are prominent examples. On the other hand mudrocks are the thinnest facies assemblage, mostly occurring as interbeds among bigger sandy units. Most of the lithologies are **gently dipping**, whereas lithologies in the basin edge extremities have a sub-horizontal dip. The lithologies in the central basin have the steepest gradients – due to Archaean tectonics. **Sedimentary structures** found in the clastic sediments of the Daspoort Formation vary across the basin. Arguably the most interesting – MRS – are found in the far west and eastern part of the basin. Ripple marks are common throughout the whole Daspoort Formation, increasing in size towards the east. They are not restricted to a specific lithofacies assemblage, but occur predominantly in cross-bedded sandstones and subordinately in pebbly sandstones, Fe-rich sandstone and horizontal laminated sandstones. Other common features include concretions, oxidised mineral nodules, imbrications, load casts, channel fills and other flow regime sole marks on bedding surfaces. **Grain size** distribution in the Daspoort basin (Figure 3.27) varies from conglomerates (very coarse) to fine mudrock (very fine). The most common grain size classification is medium- to coarse grained clastic sandstones which characterize the bedded sandstones found throughout the basin. The **lateral continuity** of the facies assemblages is restricted to outcrop interpretations and availability (Figure 3.28) for a graphical representation of facies distribution across the Daspoort Formation). Correlations made between the vertical profiles are ambiguous. The units' thicknesses vary and the exact vertical location within the whole Daspoort succession for these units can't be established when poor outcrop limits lateral correlations. The Daspoort sandstones, having a clastic and matrix supported character, have a significant amount of silica and subordinate Fe and Mg oxides. Quartz is the main **mineral** followed by Na, Al, Fe and K. This is indicative of the presence of interstitial minerals such as feldspars (Alkali and Potassium), mica minerals and heavy oxide mineral compositions. The mudstones are Fe-rich and some bedding planes reflect oxidised compositions of Fe, Cl and B. **Upward coarsening** trends signify the medium- to coarse grained sandstones of the Daspoort

Formation. Finer sediments such as mudrocks and its sub-facies, Fe-rich sandstone, have fining upward trends. Table 6 summarizes all these for every lithofacies assemblage, except for the mineral compositions.

The facies assemblage predominates in the Daspoort Formation. The cross-bedded sandstone facies assemblage is also prominent with subordinate ironstone, mudrock and pebbly sandstones which occur less frequently in the basin and do not show lateral continuity as the bedded sandstones do. Both the horizontally laminated and cross-bedded sandstone facies assemblages are found throughout the basin. Their upward coarsening nature is prominent in the southwest and in the eastern regions of the basin. The Botswana (west) and Potchefstroom (south) locations do show evidence of lateral gradation from the coarse to finer sandstones in the direction of Pretoria (Eriksson et al., 1993). This is also observed from Mokopane towards Marble Hall and Dennilton and further to the southeast of the basin (Eriksson et al., 1993). Ironstone is found in the north (Mokopane) and northeast in the Pretoria part of the basin where it is associated with mudrocks (Eriksson et al., 1993). Mudrocks on the other hand are common in the west of the basin and near Mokopane. There are numerous locations where this facies is seen interlayered with horizontally laminated sandstone. Locations include Pretoria, the Koster area; the south-eastern parts of the basin in Mpumalanga and in the northeast near Lydenburg. The pebbly sandstone facies is found in Pretoria and in the west, near Hekpoort and even further towards Botswana. Eriksson et al. (1993) also found this facies at Mokopane.









The Daspoort Formation has a generally upward coarsening appearance. The immature poorly sorted lithic arenites (including pebbly sandstones and its sub-facies, conglomerates) are found near the top of the vertical profiles mapped (Figure 3.27). The western and central parts of the basin do show major upward coarsening units, with the coarsest lithologies reaching conglomeratic proportions. Finer material such as mudrock and its sub-facies, Fe-rich sandstone, are well sorted and found mostly in the lower unit of the Daspoort succession. It is only in the far eastern basin where these lithofacies assemblages are found in the upper unit where it is exposed to weathering processes such as oxidation. The number of quartzitic units in the Pretoria area does override the amount of pebbly units for the same area; therefore the colouration in Figure 3.27 favours the quartzitic dominance. The interpretation of Figure 3.27 is based on field outcrop data. The Daspoort Formation's lithological composition is anticipated to differ from outcrop observations, especially towards the lower quartzitic unit. This variation is expected on a regional scale.

Figure 3.28 portrays the lithologies as mapped by the author and supplementary information from borehole information. This map was produced before lithofacies assemblages were established; therefore the current interpretations differ from initial observations. The legend of Figure 3.28 should be interpreted as follows:

- Fe-rich sandstone is a sub-facies assemblage of the Mudrock facies assemblage.
- The planar arenite and quartz wacke and the cross-bedded arenite and quartz wacke are synonymous with the cross-bedded sandstone facies assemblage and its subordinates (planar / trough).
- Recrystallized quartzite and medium grained sandstone are much generalised observations where no clear bedding predominates the facies assemblage of the outcrop/borehole interpretation. For interpretational purposes these would fit with the horizontally bedded sandstones.
- Pebbly sandstone is recognized as itself.

The distribution of the described individual lithofacies assemblages should be seen as events, occurring primarily due to change in energy levels in the basin during deposition. Although the units do not correlate perfectly throughout the three areas mentioned above, some general trends across the basin can be identified. Channel fills, associated with medium to coarse grained sandstone, are found throughout the basin. Mature arenites and quartzites share the same general distribution, except those which contain concretions. Two different concretions are noted; a small diameter, volcano-like concretion in the east and a bigger, dome-shaped concretion west of Pretoria. Upward coarsening, in particular of less mature sandstones, is common throughout the basin. Upward fining sequences are mostly restricted to thick units in the east. Recrystallised quartzite units are found toward the bottom of the Daspoort Formation, while arkosic wackes and other younger sandstones are found toward the upper parts of the Daspoort Formation, excluding the eastern basin. Marine activity by wave action portrayed by the cross-beds and ripple cross lamination is found in isolated units, particularly in the central basin and towards the upper units in the east where their size increases too.

Table 6: A summary of the lithofacies associations in the Daspoort Formation describing their physical properties. The main facies assemblages are in capital letters with their sub-facies assemblages in normal text. Cross-bedded sandstone is divided into its two sub-facies, i.e. trough and planar cross-bedded sandstone.

Facies Character	PEBBLY SANDSTONE	Conglomerate	MUDROCK	Fe-rich Sandstone	Trough CROSS-BEDED SANDSTONE	Planar CROSS-BEDED SANDSTONE	HORIZONTAL LAMINATED SANDSTONE	Massive Sandstone
Distribution in basin	West, central	Central	East	Central, East	Whole basin	Whole basin	Whole basin	Whole basin
Vertical thickness (m)	0.4 – 2	0.4 – 2	0.01 – 1	0.01 -0.03	0.4 - 10	0.4 - 10	0.03 - 20	2 - 30
Attitude	Gentle dip	Moderate dip	Very gentle dip	Very gentle dip	Gentle dip	Gentle dip	Gentle dip	Gentle dip
Sedimentary structures	Erosional surfaces, ripple marks, channel fills	Erosional surfaces	Concretions, nodules	Nodules, ripple marks	MRS, channel fills	MRS, ripple marks	Concretions, MRS, ripple marks	Structureless
Matrix grain size	Very coarse	Very coarse	Very fine	Fine	Coarse	Fine-medium	medium	Medium
Vertical location in succession	Upper unit	Bottom of upper unit	Upper unit	Upper unit	Upper and lower unit	Upper and lower unit	Lower unit	Upper and lower unit
Lateral Continuity	Discontinuous	Discontinuous	Discontinuous	Discontinuous	Extensive	Extensive	Extensive	Continuous
Maturity	Mature in central, poor sorting towards west	Mature in central, poor sorting towards west	Very mature	Very mature	Immature	Mature in central	Very mature	Very mature
Energy trend								

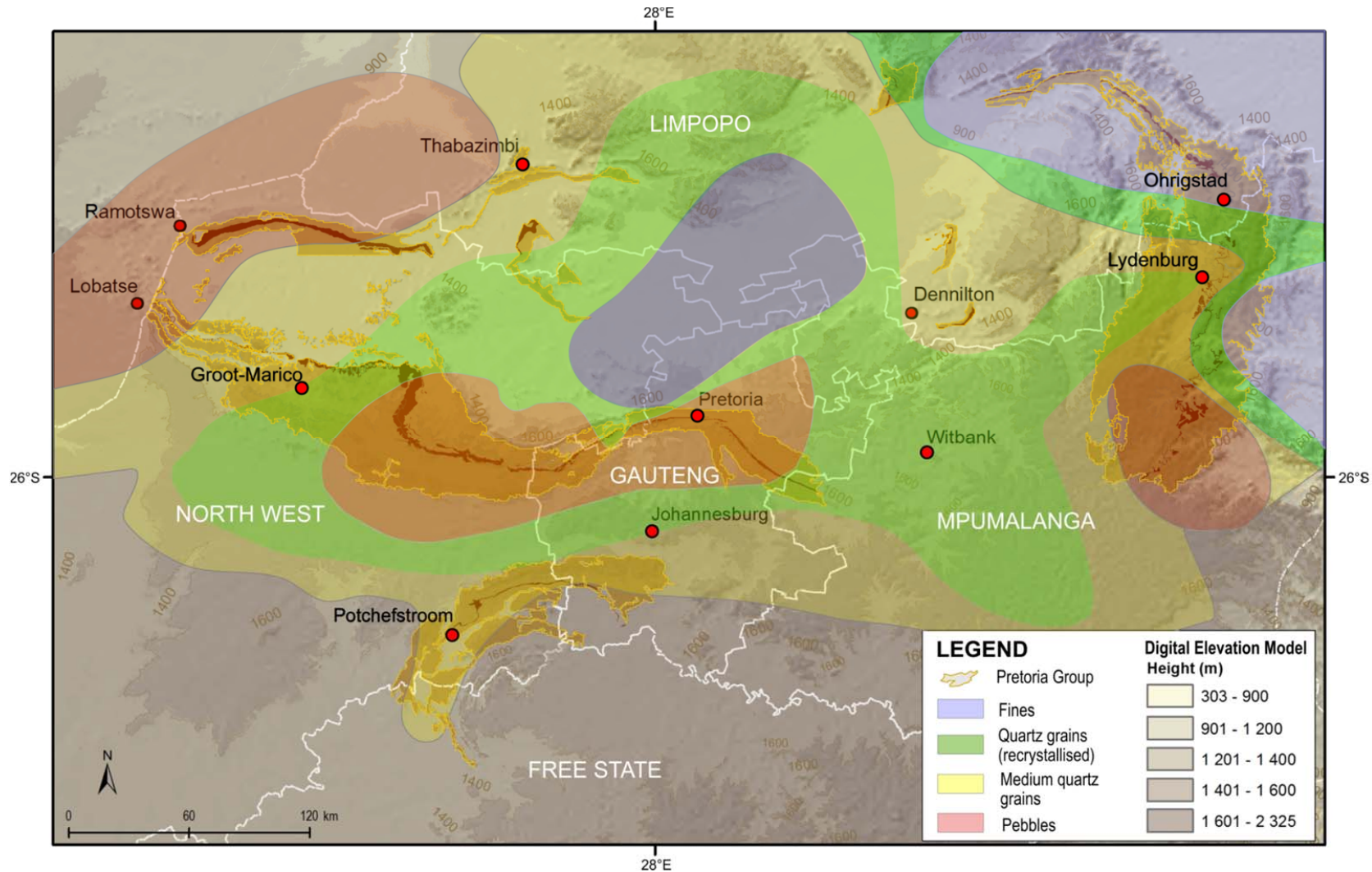

Figure 3.27: Grain size distribution across the Daspoort basin. In the legend, fines refer to the mudrock facies assemblage. The two quartz grain descriptions can be linked to the cross-bedded and horizontal laminated sandstone facies assemblages. Pebbles are associated with the pebbly sandstone lithofacies assemblage. The boundaries of the lithofacies distribution are only interpreted correlations done, using old borehole information, field outcrops and previous authors' descriptions of the lithologies found in the area. One can only speculate on the lithofacies composition of the Daspoort Formation in the central basin area and regions where outcrops are poorly preserved or non-existent.

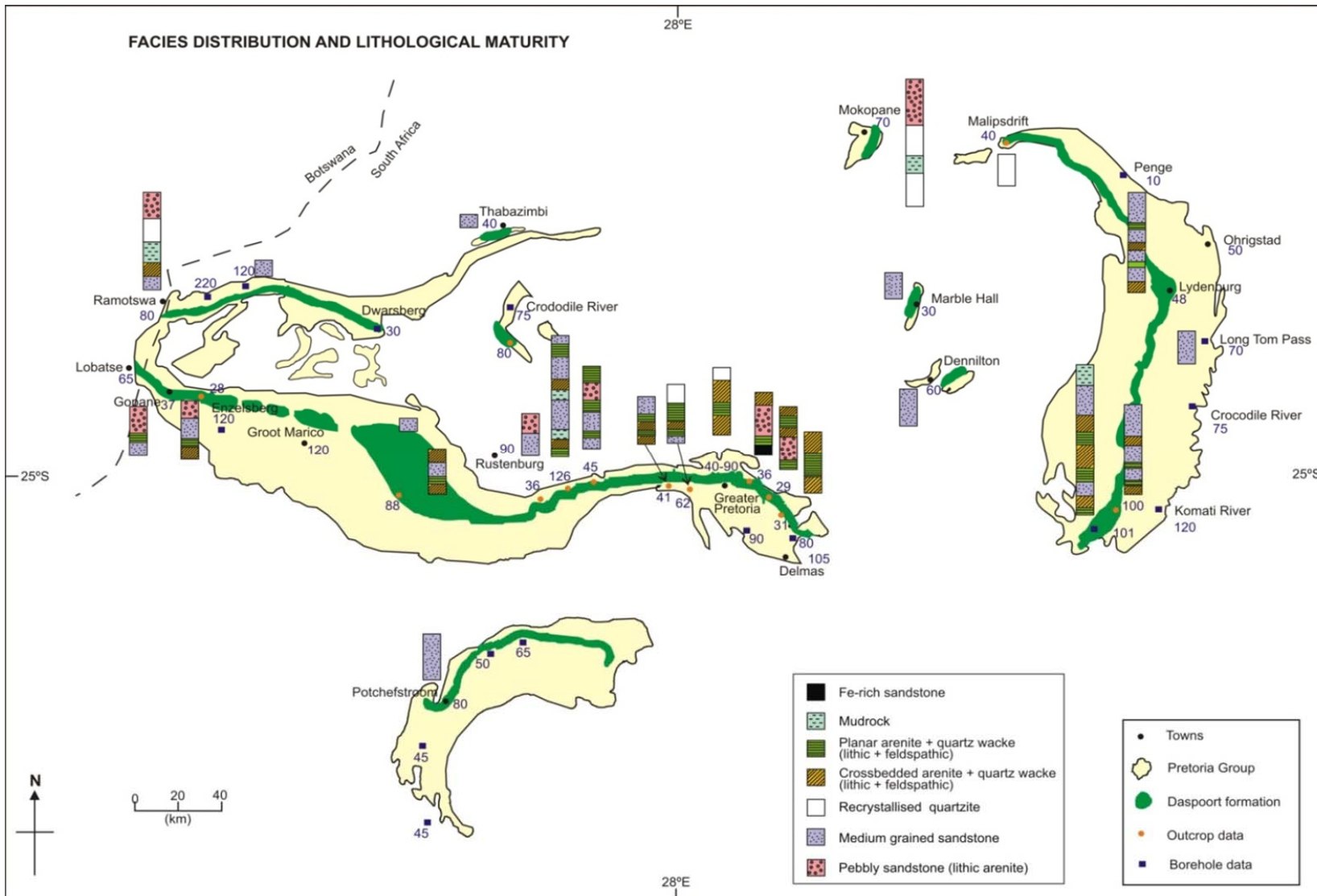

Figure 3.28: Daspoort Formation outcrop distribution seen in vertical profiles and lithological descriptions of borehole information. Borehole information is acquired from Eriksson (1993). Outcrop thicknesses are also noted. The numerics indicate Daspoort Formation thicknesses.

CHAPTER 4: DISCUSSION

4.1 Sedimentation/Uniformitarianism

The complete sedimentary record and Precambrian basin evolution are compatible with the principle of uniformitarianism (e.g., Eriksson et al., 2005), explaining also that the same processes and products are applicable for sedimentary depositional environments today and during the Palaeoproterozoic times when the Daspoort Formation was deposited. High gradient alluvial fans, shallow marine settings influenced by tidal and wave action, turbidites and low gradient sinuous braided river systems were all common palaeoenvironments during the Neo-Archaean and Palaeoproterozoic (e.g., Eriksson et al., 2005). During the Precambrian eon two known major global-scale glaciations took place and were associated with the earth's supercontinent cycle, mantle superplumes, peaks in crustal growth rates and significant biochemical changes within the atmosphere-hydrosphere, all of which evolved and changed over time (e.g., Eriksson et al., 2005, 2012b) (Figure 4.1). Studies of the Palaeoproterozoic glacial deposits on the Kaapvaal Craton appear not to support the 'Snowball Earth Hypothesis' (SEH) (Eriksson et al., 2011).

Eustacy and palaeoclimate modified the first-order role of plate tectonics and magmatic thermal processes which, in conjunction, controlled the evolution and sedimentary history of the Precambrian basins (Eriksson et al., 2005). These and processes such as erosion, diagenesis and sediment transport are all prominent factors that influenced the sequence stratigraphy, especially considering the nature of the Pretoria Group's depositional environments. In order to understand the sedimentary record of the Precambrian, in particularly the Neoproterozoic, the basic interpretation of sedimentary systems and their applications are fundamental. This includes sequence architecture and sedimentary facies assemblages which lead to the comprehension of sea level changes, global and local (Eriksson et al., 2005). This concept is cardinal in order to assess tectonic setting, thermal controls and continental freeboard (e.g., Eriksson, 1999).

Two postulated "super-events" (Eriksson et al., 2004) occurred at c. 2.7 Ga and at c. 2.2–1.8 Ga (Figure 4.1) and changed the face of the Earth. During the latter, epeiric seas of various types developed along continental margins or along continental interiors. Focussing on the Transvaal Supergroup on the Kaapvaal craton, two epeiric seas developed in the upper, clastic portion (c. 2.4–2.1 Ga) (Eriksson et al., 2005). The Silverton Formation depicts the maximum development of the younger epeiric environment. A combination of braid-delta systems whose detritus was reworked by distal turbidites along the margins of a relatively steep-sided epeiric basin is interpreted for the earlier (Timeball Hill Formation) epeiric sea. For the Silverton sea, sub-storm wave base pelagic deposits in offshore mud belts as well as storm wave-deposited fine sandstones were pertinent (Eriksson et al., 2002b). The Daspoort Formation is interpreted as the sandy (shoreline) precursor of the Silverton epeiric embayment, a model obviously depending on views of the structural development of the basin.

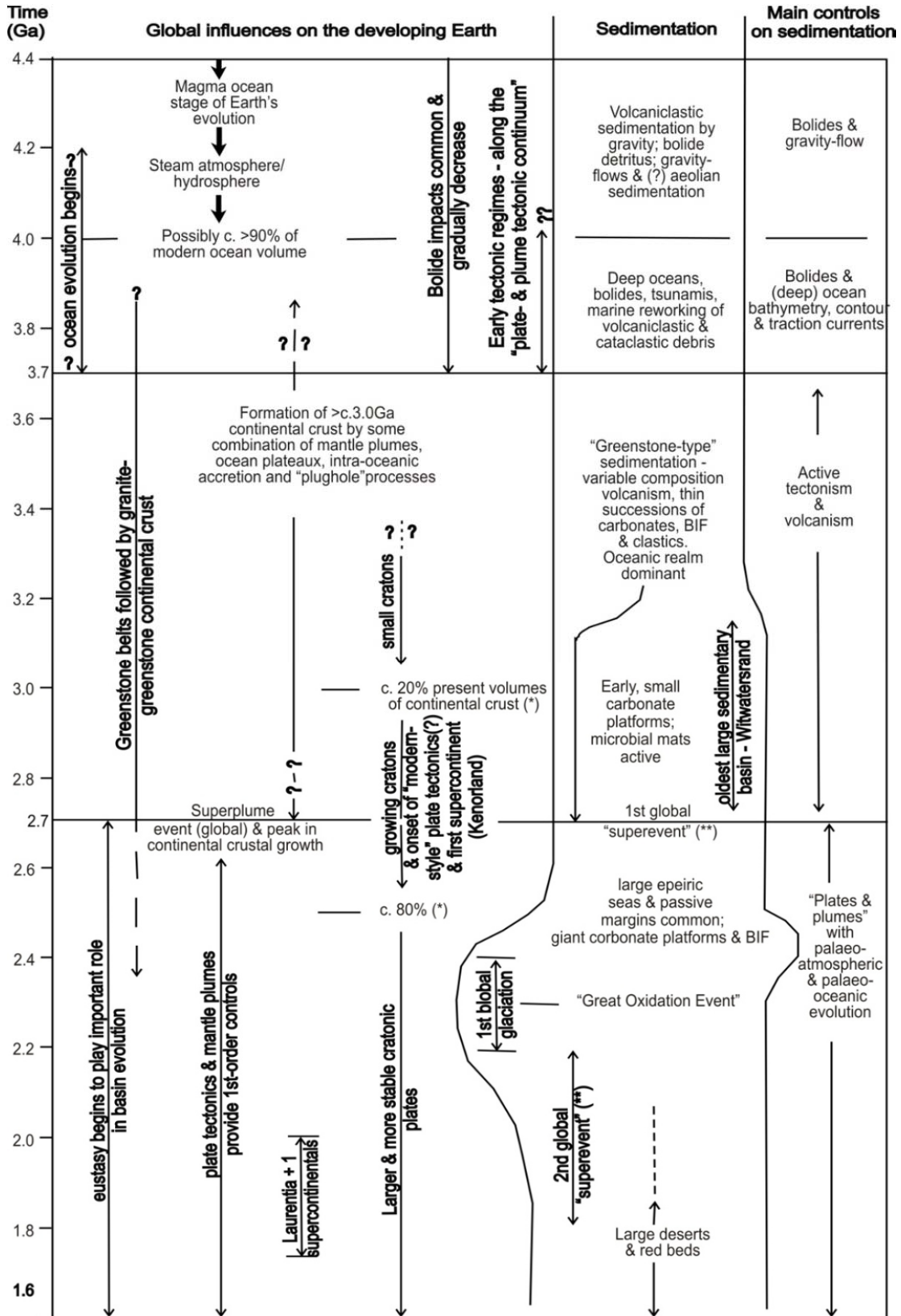

Figure 4.1: Schematic summary time chart, showing main influences on Earth evolution and sedimentation from c. 4.4 Ga to 1.6 Ga. Modified after Eriksson et al. 2004.

The Precambrian sedimentary record sheds light on global sedimentary evolution. The understanding of sequence stratigraphy is fundamental to interpret sedimentary facies architecture and sea level changes. Braided channel systems are common in alluvial and fluvial settings in the Palaeoproterozoic sedimentary record. The same can be said of deltas, turbidity currents and wave- and tide-dominated shoreface settings. The river systems often debouched into epeiric seas with weak wave and mesotidal energies, and braid-deltas largely formed (Eriksson et al., 2004).

There is also relevance here for a brief discussion regarding the 'Great Oxidation Event' (GOE). This phenomenon envisages the biological generation of free oxygen in the Earth's atmosphere at ca. 2.4-2.3 Ga (e.g., Holland, 2009). Excessive oxygen released during the Palaeoproterozoic events could have caused anaerobic organisms to vanish. Cyanobacteria, by producing oxygen, were essentially responsible for what was likely the largest extinction event in Earth's history (Altermann et al., 2003). The Kaapvaal Craton has relevant preserved examples of iron pigmentation of clastic sedimentary strata within the Pretoria Group in particular (Eriksson and Cheney, 1992). Colouration is seen in the matrix minerals (red beds *sensu lato*) which provide partial evidence for a GOE, existing at 2.3 Ga to 1.8 Ga (Eriksson and Cheney, 1992). This event would have been marked by oxidizing palaeo-atmospheric conditions during early Pretoria Group sediment diagenesis (Eriksson and Cheney, 1992). According to Voegelin et al. (2010), Mo isotopic data from Ghaap Group carbonates could be an indirect parameter to determine the extent of atmospheric palaeoenvironmental influences on a basin-scale for terranes such as the Kaapvaal Craton.

The Daspoort Formation consists of clastic sedimentary rocks which bear a record of many depositional influences and palaeocurrent patterns due its regional variability. The inferred tectonic framework of the Daspoort Formation reflects heterogeneous characteristics on a regional scale which influenced sedimentation and diagenesis regionally, from the time of preceding Strubenkop Formation mudrock deposition until deposition of the post-Daspoort Magaliesberg Formation sandstones. Evidence for enhanced palaeoslopes is commonly found in these formations where fluvial sediments occur. These are interpreted as channel systems with different flow regimes accompanied by local accumulation of muddy detritus in temporary playa lakes (cf., "mud playas" of Rainbird, 1992; see also Eriksson et al., 2009b). The latter authors also suggest a greenhouse palaeo-atmosphere for the above-mentioned systems for at least part of the Kaapvaal Craton from 2.3 Ga to 1.8 Ga which promotes the hypothesis of a diachronous change in oxygen levels globally during the Palaeoproterozoic (Eriksson et al., 2009b).

The upward-coarsening trends seen in the thicker Daspoort Formation units indicate an energy surge going up in the succession. These are usually bounded by erosional contacts indicating erosion and a hiatus. Such larger scale energy pulses in the Daspoort Formation can be interpolated across a strike direction of the flow of a fluvial system or along a regional coastline setting where three dimensional facies stacking patterns can be identified (Eriksson et al., 2012a). The very coarse trends seen in the western Daspoort basin conform to specific major flow directions observed there. The changes in relative maturity of the clastic sedimentary rocks and other parameters reveal that western-most fluvial depositional systems prograde into the basin from the west. In other words, the coarser material would

be found closer to the fluvial source and finer material more distally towards the basin. A regressive systems tract passing laterally into a shoreline where shallow marine and fluvial depositional environments meet under above-mentioned conditions is suggested for the western Daspoort basin. However, these upward-coarsening trends can also appear in inferred shallow marine sedimentary rocks which lie to the east, distally (Eriksson, 2012a). These eastern facies associations would have been associated with finer sediments transported into the basin, settling in the more distal, easterly subtidal areas.

It is believed that the Daspoort palaeo-coastline reflects an episodic change in base level rather than one dominated simply by tides. The change in lithofacies distribution especially in the central basin and to a lesser extent in the western basin points to sporadic but consistent upward-coarsening sequences. According to Eriksson (2012a) tides would typically result in upward-fining sequences onto the upper tidal flat as well as towards the deeper distal marine environment, under overall regressive conditions.

4.2 Stratigraphic setting and structure

To understand the nature of the Daspoort Formation's tectonic genesis, stratigraphically adjacent formations are worth mentioning. It is believed that the underlying Strubenkop mudrocks represent a lacustrine basin where, according to Eriksson et al. (1991) the Dwaalheuwel fan-deltas merged. A half-graben environment has been associated with the Strubenkop Formation due to the inferred northern source of the underlying formations (Eriksson et al., 1993). The Silverton Formation, overlying the Daspoort sandstones, consists of thick mudrocks, with some associated volcanic lithologies in its composition. This unit is considered to be compatible with a highstand systems tract associated with low energy traits, but Clendenin et al. (1990) and Eriksson (1991) suggested a lacustrine delta and fan-delta setting (similar to the Strubenkop Formation). The overlying Magaliesberg Formation possibly represents the regressive shoreline of the Silverton Formation; both its interpreted palaeosalinity (from boron values; Figure 4.11) and lateral thickness distribution across the Pretoria basin concur with the late stage of a highstand facies tract of an epeiric sea, further supported by sedimentary features such as herringbone cross-bedding, carbonate rocks, flaser bedding and interference ripple marks (Eriksson, 1992). These are all characteristic of a marine setting. The genesis of such a model may be compatible with the envisaged intracratonic half-graben setting of Eriksson et al. (1991).

The Daspoort Formation lies stratigraphically between (if models are assumed to be correct); deposits of an epeiric sea margin (Silverton-Magaliesberg Formations, above, see Figure 4.3) and those of a lacustrine fan-delta palaeoenvironment (Strubenkop Formation, below), both settings possibly influenced by half-grabens. The Daspoort Formation doesn't lend itself to much structural interpretation due to a lack of known suitable data. Evidence for tectonic movements includes only the lateral dextral fault displacement prominently seen at outcrops towards the west of Pretoria. The change of the average dip inclination from steep in the central basin to more gradual towards the east and west is prominent in the Pretoria area. The latter characteristic may well be due to the Transvaal Supergroup having been deposited around the Granitic Johannesburg Dome, which lies south of the

central basin and which was active during and after deposition of the Pretoria Group (e.g., Eriksson et al., 1991). In post-Daspoort times, continuous sedimentation within the Pretoria Group depository, where incompetent lithologies became buried under accumulated sedimentary strata. This occurred over a lateral distance across the Daspoort Formation, but its greatest impact is in the central basin, facing north, where the Pretoria Group was thus preserved at its steepest angles.

Daspoort-Silverton-Magaliesberg deposition occurred under post-rift thermal subsidence, similar to the Timeball Hill epeiric conditions which were part of the first Pretoria Group basin evolutionary cycle (Eriksson et al., 2001). Following the earlier active rifting of the Pretoria Group basin (during Hekpoort-Dwaalheuwel-Boshoek formations deposition), the Silverton lowstand systems tract deposits formed as WNW-directed transgression occurred, causing an epeiric sea to form on the Kaapvaal craton (Eriksson et al., 2001). It can be deduced that Pretoria Group sedimentation as a whole comprised two cycles of prerift uplift - mechanical rifting and thermal subsidence (Eriksson et al., 2001). The significant Hekpoort and flood basalts were most likely associated with the rifting phase and thermal subsidence with the Daspoort-Magaliesberg phase, which supports the hypothesis that magmatism and rising post-glacial sea levels were contributing factors to the second cycle of sedimentation in the Pretoria Group (Eriksson et al., 2001). Unfortunately evidence for the tectonic framework of the Daspoort Formation is uncommon due to the intracratonic nature of the Pretoria Group (Figure 1.2).

The angle of inclination of preserved Pretoria Group strata was strongly influenced by post-Pretoria Group Bushveld intrusion, and locally around the Johannesburg dome by its uplift. Uplift of the Johannesburg dome occurred over an extensive period, syn- and post- Pretoria sedimentation. Post-Pretoria times accounted for the majority of this uplift, as can be observed from the Transvaal rocks which curve around the dome.

This thesis does not focus on the deformational events and structures associated with the Pretoria Group and even less those that are inferred for the Transvaal Supergroup as a whole. Master (2009) suggested greenschist facies metamorphism for the Pretoria Group, which is also correlated with the Segwagwa Group in south-eastern Botswana. Such an association is reminiscent of a continental back-arc sequence but there is no supporting evidence known from the Pretoria Group basin-fill.

Epeiric seas/embayments are shallow marine bodies with an estimated maximum depth of 200 m (Eriksson et al., 2008). The Strubenkop-Daspoort-Silverton-Magaliesberg embayment formed in a cratonic basin environment; although some examples extend inland from a continental margin being underlain continental crust, therefore occurring on various tectonic settings as suggested by Eriksson (et al., 2008). There is a distinction between *epeiric embayments* and *epeiric seaways*. In general, seaways are much bigger (trans-continental in scale) shallow oceans (Bouma et al., 1992) whereas embayments are smaller (sub-continental in scale) and shallower (Eriksson et al., 2008). There are other features which distinguish the two, but are irrelevant for this discussion. For more background on this topic see Eriksson et al., 2008. MRS is found on either poles of the Daspoort basin; east and west. Vertical successions in this Proterozoic embayment show paradoxically distinctive sequence stratigraphic architectures, but similarities include MRS, ripple marks etc. The differences could indicate non-

uniformitarian growth of microbial mats (e.g., Sarkar et al., 2004). Clastic sediments and high energy 'events' are characteristic of the Daspoort embayment, especially in the eastern basin. These, together with fluvial influx from the west, are reflective of epeiric sea coastlines (e.g. Eriksson et al., 2008).

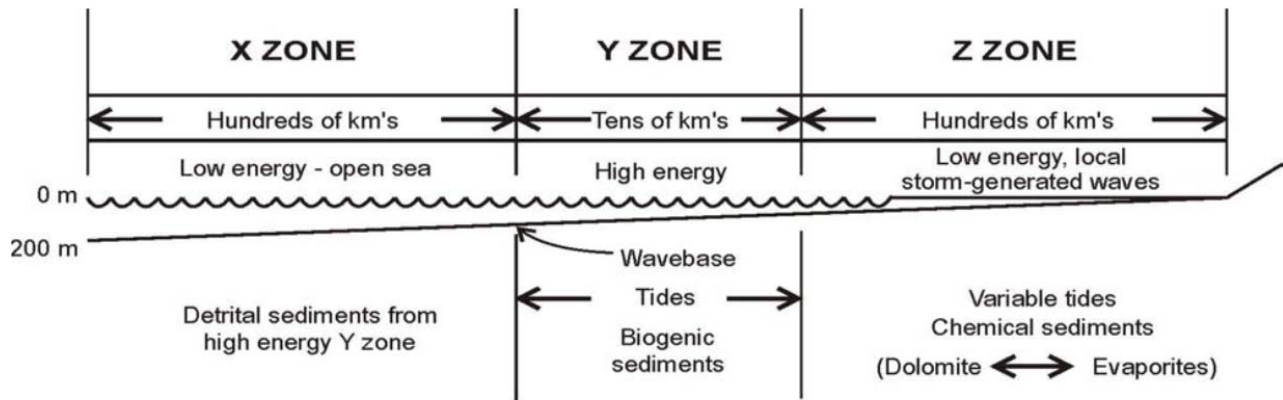

Figure 4.2: The classic Shaw (1964)–Irwin (1965) epeiric sea model. After Eriksson et al., 2008.

Shaw (1964) and Irwin (1965) build a model for epeiric seas (Figure 4.2), but it was related to low-energy carbonate facies assemblages. This model can be used to interpret clastic sedimentary embayments as well. Eriksson (et al., 2008) used a similar diagram for the Silverton-Magaliesberg epeiric sea depicting three different zones of energy and facies assemblages (Figure 4.3). The Daspoort Formation displays similar characteristics, although the facies assemblages are vastly different. Shaw (1964) and Irwin (1965) identified 3 key areas and depicted them as:

- (1) a wide, low-energy, open-sea zone below wave-base, ("X")**
- (2) a narrow, high energy, wave- and tide influenced zone ("Y")**
- (3) a second wide, low-energy zone ("Z") on the landward side, with generally poor circulation, minimal tides and insignificant storm-generated wave action**

The central Daspoort Formation, where outcrops are absent, can be linked to the "X" zone. It is here where the facies assemblages from the eastern and western basin are believed to amalgamate under post Proterozoic lithologies. The basin is believed to be deeper in this area. The "Y" zone can be associated with the shallow high energy coastline found in the eastern basin. Sedimentary architectural evidence from the vertical successions in this area indicates tide dominated shelf environments. The fluvial dominated western basin can not be associated with the model of Shaw (1964) and Irwin (1965).

Eriksson (et al., 2008) described the 2km thick Silverton Formation as an intracratonic sag basin which has a c. 65 m thick sandy unit which occurs at the base of the Silverton succession. They associate this unit with a braid-deltaic deposition and turbidity current reworking of the Silverton Formation and interpret it as a transgressive systems tract which was preceded with rifting (Figure 4.3 and Figure 4.7

for an explanation of the physical characteristics of a TST and the Silverton coastline as well as Figure 7.26 in Appendices for turbidity flow characteristics and Bouma's sequence).

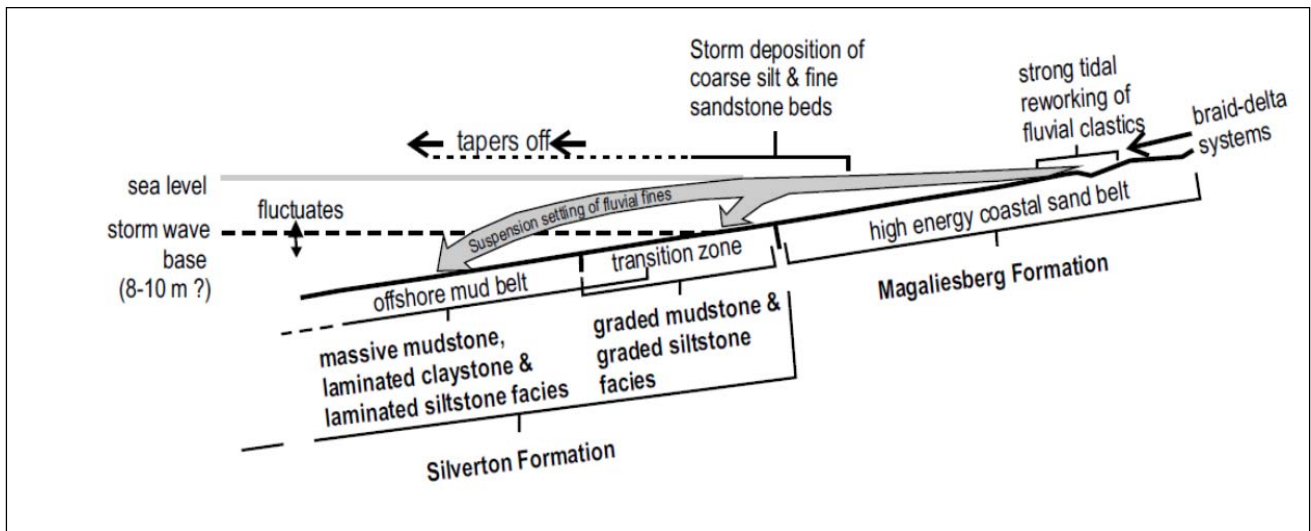

Figure 4.3: The sedimentary model for the Silverton-Magaliesberg shallow marine environment (an epeiric sea model). Modified after Eriksson et al., (2002); in Parizot et al., 2005. It is envisaged that the Daspoort Formation had similar fluvial (from the west) and tidal (from the east) influences.

There exist certain lithological associations of the Early Proterozoic which are indicative of the tectonic environment in which they formed. These assemblages are briefly discussed in the lithofacies chapter. The quartzite – pelite – carbonate association (QPC) is generally thought to reflect cratonic basin deposits, whereas the bimodal volcanic-arkose-conglomerate association (BVAC) is interpreted as reflecting continental rifting (e.g. Condie, 1989). The Daspoort Formation, like the Pretoria Group as a whole, doesn't commonly contain conglomerates or carbonates. One can argue that the pebbly sandstones of the Daspoort Formation do resemble conglomerate character. The scarcity of these lithotypes could infer the onset of continental rifting during the Early Proterozoic on the Kaapvaal Craton (cf., Schreiber et al., 1992). Using Condie's QPC classification it would seem appropriate for the Pretoria Group to be portrayed as a stable tectonic setting on the Kaapvaal craton (Figure 2 in Eriksson et al., 2001 similarly suggests a subtle tectonic instability within an overall intracratonic setting).

Daspoort sandstones in Mpumalanga and especially the eastern Limpopo provinces have mudrock interbeds. These are less common in the central parts of the basin where quartzites and to a lesser extent, arenites are dominant. This distribution is seemingly opposite to the one postulated by Schreiber et al. (1992) for the whole Pretoria Group. They found that mudrock and cross-bedded quartzitic sandstone make up 75.5% and 71% respectively of the preserved Pretoria Group in this eastern area, whereas the central basin successions have 66% of these lithologies. Schreiber et al. (1992) also envisaged a higher occurrence of arkoses in the central basin compared to the eastern basin, but comparing the Daspoort Formation's arkose distribution to that inferred for the Pretoria Group as a whole, it is somewhat surprising to see an increase of arkosic rocks in the east for the Daspoort. There are no volcanic rocks found in the Daspoort Formation. The lithological assemblages

indicate tectonic stability and the cratonic conditions on which the Pretoria Group was formed, especially evident in the lower part of the stratigraphic succession of the Pretoria Group (Schreiber et al., 1992). These authors also suggest that the increase in arkose deposition and volcanic activity (Hekpoort and associated immature sandstone formations in the medial Pretoria Group) could be as a result of basement uplift and/or continental rifting. Lithic sandstones of the Pretoria Group can be linked to recycled orogen provenance terranes and form part of an intracratonic interpretational provenance plot (see Schreiber et al., 1992).

Schreiber et al. (1992) provide geochemically- and petrographically-based plots of the upper Pretoria Group which indicate increased tectonic instability where basement uplift caused erosion to produce feldspar-rich sediments filling the basin, especially those in the Daspoort Formation. The stable lower Pretoria Group's transition into epeiric and structural disturbance can be accommodated by the postulated depositional model for the Strubenkop-Daspoort-Silverton-Magaliesberg model as described by Eriksson et al. (2002). Here we see evidence of shallow marine shelf sequences interchanging with tidal and fluvial reworking in a shallow water environment (Figure 4.3).

4.3 Lithofacies

Various sedimentary lithofacies assemblages are identified throughout the Daspoort Formation. They are distinctive, but do amalgamate in some areas. Vertical profiles are scarce, but isolated outcrops and road cuttings supported the interpretations initially made. Typical examples of environmental interpretations in the Daspoort Formation included: sandy braided river, point bars in highly sinuous rivers, degrading alluvial fan, sandy tidal flat, tidal creek point bars. These are evident in upward thinning sequences.

Pebbly sandstones are common in the middle and upper parts of the Daspoort succession. They have an arkosic matrix, but lithic arenite assemblages are also found in the central and western Daspoort basin. The pebbles are well-rounded which reflects high energy environments. This, together with numerous other fluvial-supported textures such as channel fills, mudclasts, ripple cross lamination, caliche nodules, desiccation cracks and lateral accretion surfaces support a sandy fluvial-like sedimentary environment, perhaps debouching into a gradually filling intracratonic basin – the would-be Silverton-Magaliesberg Epeiric Sea at the time. Imbrications are common in the beds' floor. This indicates high flow regimes and steep gradients although these occurrences seem channelled and laterally discontinuous. The unlikely events of violent storms with strong wave action in this shallow epeiric sea could have rounded these clasts with the help of tidal action. These facies assemblages are not common in marine environments, but can enter an intracratonic basin locally, though it probably won't be well preserved (Eriksson et al., 1993). Little evidence was found to support the latter hypothesis. The arkosic pebbly units generally are immature which are not associated with shallow marine environments. They formed in a high gradient shelf setting (except in the far west) where coarse sediments would be expected. The pebbly sandstone facies indicate rather a proximal deposit, perhaps

distal alluvial fans. This facies wouldn't be described as clast supported, but imbrications in the unit's floor do occur and poorly developed horizontal bedding is observed. These features are similar to the facies described by Miall (1978) for braidplain and distal fan settings. They envisaged trough cross bedded clast supported gravel facies for this setting as well.

The upper Daspoort Formation and lower Silverton Formation have regional similarities, related to their age equivalence (e.g., Catuneanu and Eriksson, 1999). Tidal influences across the basin, particularly the various sandstone tidalite facies associations, are correlative. The upper conglomerates (sub-facies) found at Faerie Glen in particular, show evidence of incision (erosive base – a third order subaerial unconformity, load casts, slumping at base of unit, scouring and flute marks). This can be related to the upward accommodation change during sedimentation. The unconformity separates a lower Daspoort unit, described by Eriksson et al., 2005, as a sandstone, mudrock and ironstone facies assemblage, from an upper pebbly sandstone unit. This incision is traceable throughout the Daspoort's lower unit. It implies the reworking of the second-order maximum regressive surface at the base of the Daspoort Formation (Eriksson et al., 2005).

Mudrocks form the gradational contact zone at the bottom of the Daspoort Formation's lower unit in the western basin. A more abrupt contact is seen elsewhere in the basin which is similar to the Silverton Formation contact throughout the basin. The gradual change from mudrocks to sandstone in the western basin, from the envisaged shallow lacustrine basin of the Strubenkop Formation (Eriksson et al., 2005), indicate increasing sediment supply by fluvial systems debouching into a shallow basin environment. The initial mudrock assemblage at the bottom of the Daspoort Formation, perhaps even eroding the upper Strubenkop Formation, could indicate periods of relatively lower energy in depositional systems in the basin, possibly reflecting palaeoclimatic influences, or even transport of argillaceous detritus (cf. Eriksson et al., 2009). Button (1973) suggested that these are offshore muds, but the Daspoort's mudrocks are indicative of low energy suspension sedimentation (Eriksson et al., 1993). Suspended mud has a low resistance to flow, or poor traction. If an assumed alluvial-fluvial model would be chosen at the expense of a marine model, the mud could be interchannel deposits, or shallow lakes next to advancing fan lobes (Eriksson et al., 1993), but the latter wasn't considered due to the various structure complexities encountered in the basin. Mudrocks in the eastern basin are limited to the upper parts of the Daspoort successions, usually grading into iron-rich sandstone. The mudrocks in the upper unit can be interpreted as a precursor to the overlying Silverton Formation. Outcrops mapped didn't expose the bottom contact with the Strubenkop Formation. The massive ripple marks found in the iron-rich sandstone lithofacies assemblage indicate shallow marine conditions. It is envisaged that the upper Daspoort unit thickens at the expense of the lower unit towards the eastern basin (Figure 4.5).

Ironstones were found in the northern and northeastern parts of the basin by numerous researchers. This lithofacies assemblage probably formed under reducing conditions proximal to the influx of sediments into the basin. This could be similar to a small lake within a quiet environment, but could indicate the initial stages of the developing Silverton embayment.

Cross-bedded sandstones are the most common lithofacies assemblage in the Daspoort Formation. These are found throughout the basin, but are most prominent in the western basin (see Koster road cutting cross section) where channel fills and other related fluvial architectural elements saturate the succession's textural countenance. The eastern basin's homogenous sandstones display cross-bedding on a much bigger scale. The absence of other textural elements infers a higher energy environment which bypassed or destroyed other physical characteristics (if there was any) of the sandstones. The central basin seem to inherit parts of the western and eastern basin's characteristics; cross-bedding being evidently smaller, a variety of sandstone compositions and architectural elements. These features favour characteristics more to the west than the east. This suggest that the marine environment is more prominent in the eastern basin and inferred for a smaller area compared to the vast fluvial evidence for the western basin moving towards the central area. **Hummocky cross-stratification sandstones** are scarce in the Daspoort basin. These are usually indicative of bimodal flow regimes which form storm waves in an ocean. Little other evidence suggests that the Daspoort terrain was once an ocean, perhaps just an epeiric sea. Tanner's figure (see Lithofacies Chapter) indicates that not only waves, but currents were present in the Daspoort basin. Low hummocks with random orientations are usually formed offshore by redeposition along flooding rivers below the fair weather wave base (Dott et al., 1983). Hummocky cross stratification could be inferred at the Koster road cutting (see Lithofacies chapter) as architectural elements for sinuous rivers in flood depositing material on the shore face at a fluvial congruence with the marine environment or when a tidal flat became flooded, but support for such events lacks substantial evidence. Dott et al., 1983 reckons that landward deposits feature smaller bed forms, because storm waves shrink moving onshore. He also supports the fact that hummocky stratified sandstones can form in a fluvial environment, but the unit should comprise only of sand. This is the case at the Koster road cutting where various cross-bedded sandy units with various grain sizes are observed. The scarcity of hummocky cross-stratification in the Daspoort Formation conforms to the envisaged fluvial and/or shallow marine environment as hummocky cross-stratification infers high energy wave action below the fair-weather wave base (Eriksson, 2012). This sedimentary architecture is associated with water depths in excess of 15m which is not postulated for any locality in the Daspoort Formation basin based on ripple mark morphology calculations across the basin which yielded maximum water depths below 1m.

Horizontally laminated sandstone is less common than cross-laminated sandstone, but thick beds (up to 60 cm) are also present; they often have wavy bedding contacts and occasionally convoluted which is analogous to upper flow regime surfaces at the plane bed-antidune interface (Collinson and Thompson, 1982).

The mature **arenites** of the combined sandstone facies (crossbedded and horizontal laminated), dominating the facies assemblages of the Daspoort Formation, are indicative of high energy marine environments near the shoreface. Although associated with the abovementioned setting, these rocks are compatible with aeolian (for example, Lancaster, 1981), deltaic (for example, Tankard and Barwis, 1982) and fluvial (for example, Condie, 1989; Beukes and Cairncross, 1991) environments as well (Eriksson et al., 1993). Thin horizontal bedded units reflect in many cases upper flow regimes or when

thicker, beach deposits. The thicker quartzites are generally recrystallised due to diagenesis and regional metamorphism in the Pretoria Group. Herringbone cross-bedding, bimodal palaeocurrents and the sheet-like nature of the sandstone facies could support a shallow marine setting (Eriksson et al., 1993), though the features named above can be found in fluvial channels as well (Selley, 1968; Alam et al., 1982).

The eastern basin has poor preserved Daspoort – Strubenkop contacts. It is believed that the massive sandstones, characterizing the eastern basin successions, dominated the basin shelf environment. A high stand system tract would explain the progradation and aggradation of sediments towards the central of the basin at a moderate rate. The base level rise and a normal transgression are created. The upper unit incises the lower unit towards the eastern basin.

Graded coarse siltstone and fine grained sandstone units are not found throughout the predominant coarse Daspoort sandstones. This indicates that large storm waves were absent in the epeiric palaeoenvironment (Eriksson et al., 1995). Subsequently shallow water depths are postulated for the Daspoort Formation with basin floor gradients being gentle, especially at either pole; the western and eastern basin extremities.

Eriksson (et al., 1993) build a well constructed fan-braidplain model (Figure 4.4) assuming that the pebbly sandstone facies is the most proximal, followed by the various sandstone facies (coarse first, then finer) and then the mudrock and ironstone facies concluding the sequence as the most distal facies assemblages. Considering his model, the basin filled up from west to east if the postulated sequence of facies assemblages are followed from coarse to fine grained across the basin.

4.4 Regional patterns

The upward-fining and upward-coarsening cycles are important factors in the determination of the Daspoort Formation's energy environment.

Upward-fining units are less observed in field outcrops than the upward-coarsening units. The former are well developed in the eastern basin, where massive sandstones are common. This trend is likely to delineate, at least partly, the extent of upper tidal flat palaeo-environments, with it being believed that the eastern basin can be equated with a tidal coastline. The vertical extent of the upward-fining cycles decreases towards the immediate west in the eastern basin. The sediments in the eastern part of the preserved basin are seen to reflect a position progressively basinwards towards the east where a gentle shelf slope is inferred to have been responsible for lower energy observations. This area is reminiscent of tidal action, rather than tide-dominated. Evidence is clearly seen in the big cross-stratified facies and massive sandstones with isolated smaller scale trough cross-lamination and channel-fills. These are usually bounded by erosive contacts.

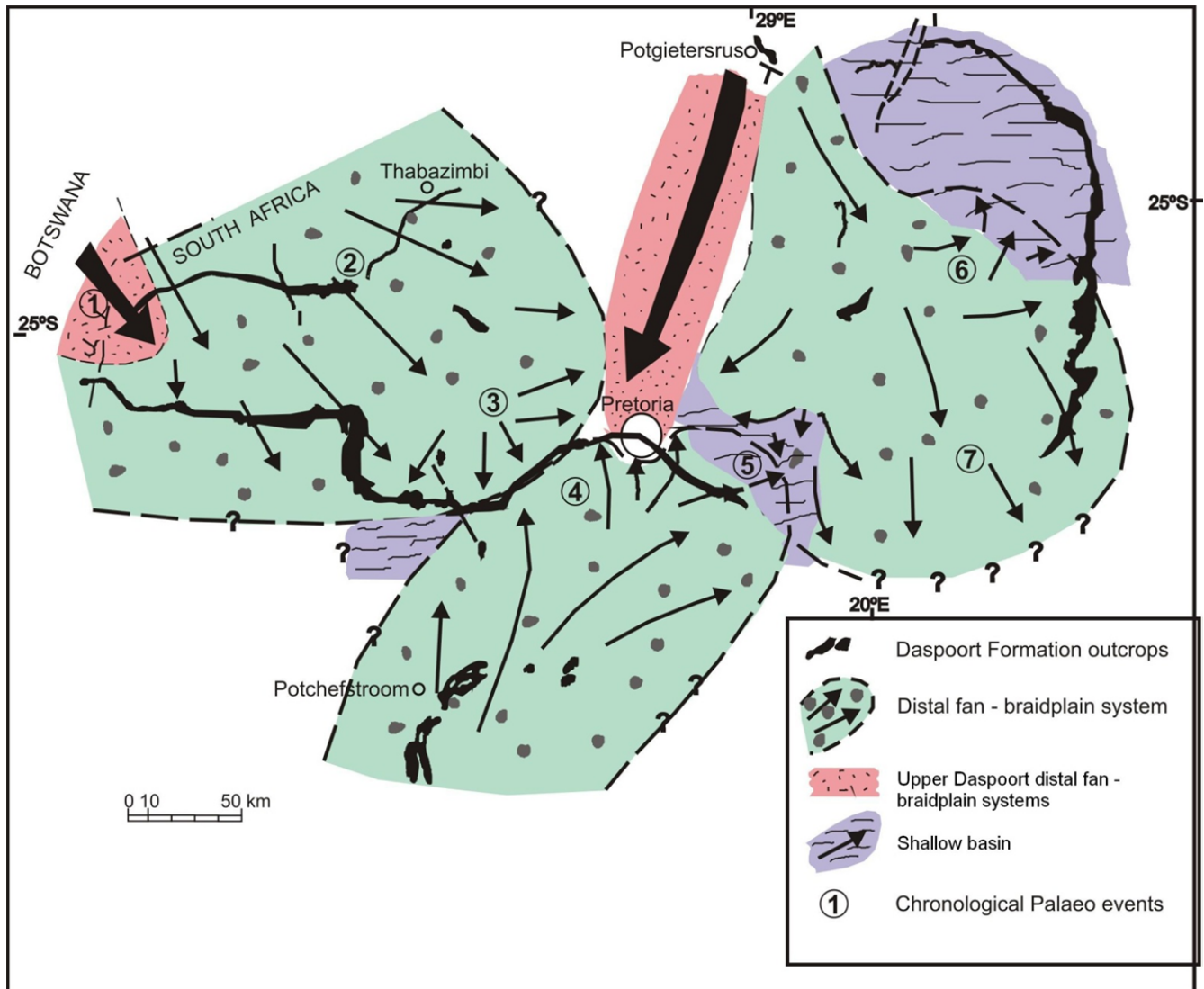

Figure 4.4: Fluvial Braidplain model envisaged by Eriksson et al., 1993.

The coarsening-upward units are found lower in the succession in the eastern basin. This feature is not as common as the fluvial progression into the basin in the western Daspoort Formation where regressive conditions are believed to have dominated over the shoreline environment. The inferred steeper gradient of the basin edges in the west also supports higher energy conditions. Fluvial reworking and advancement towards the basin from various source areas (N, S and particularly, W) gave rise to the clastic material being deposited in a central-easterly-lying shallow marine basin.

The central and western parts of the Daspoort basin are marked by fluvial architectural elements. Upward-coarsening cycles in these areas are reminiscent of high energy prograding systems developing towards a basin. This is indicative of a regressive systems tract where an influx of sediment is deposited in the basin. The Daspoort basin probably wasn't very deep (less than 200m) and its fill displays mostly medium- to coarse-grained sandy deposits especially in the central and western parts of the basin. Clastic material within a shallow marine area portraying upward-coarsening cycles could also classify as

a beach environment. Fines would migrate further in suspension towards the basin to form part of a shallow marine subtidal environment.

The variable conditions under which the Daspoort Formation formed, make its intracratonic basin coastline all the more intricate to evaluate. The heavier, coarser sediments would reside to a lower tidal flat if the coastline was ruled by tides. These would fine and aggrades upwards, and the observation that towards, the east, that is basinwards, there is a change to higher (cf., upper) tidal flat deposits in the shallow marine basin, is indicative of regressive shorelines; however, transgressions are also evident.

Thus far it has been noted that well-developed transgressive systems tracts are sometimes not well established in the Precambrian (Sarkar et al., 2005). It has rather been noted that stacked systems tracts of normal regressive deposits that may have been separated by thin veneers of transgressive deposits, which can be reduced to transgressive lags occur (Sarkar et al., 2005; Schieber et al., 2006).

The poor preservation of the fluvial to coastal section of the systems tracts in the Pretoria basin, in particular the Daspoort-Silverton-Magaliesberg marine environment, could be due to high energy wave action in the upper shoreface during shoreline transgression (Schieber et al., 2006; Eriksson et al., 2012a). The low gradient of the studied rock units and stratigraphically bounding formations, possible (s)low sediment supply into the basin and rapid transgressions could explain the weak development of transgressive shale above wave ravinement surfaces (Sarkar et al., 2005; Schieber et al., 2006; Eriksson et al., 2012a).

Eriksson et al. (1993) proposed a palaeoenvironmental model for the Daspoort Formation. Fan-fluvial braidplains were common in the west, but they were drowned towards the east where the basin started filling up, forming a shallow epeiric sea. The ESE – WNW palaeocurrent directions measured as well as the pebbly lithologies from these more proximal areas support a fluvial model which subsequently gives way to a marine transgression. Planar and trough cross-stratification, pebbly and muddy interbeds in sandstone facies and channel-fills of various sizes are used as evidence by Eriksson et al. (1993) to support a predominating braided river system or wet alluvial fans (Nielsen, 1982) for the Daspoort Formation. High flow rates of these braided river deposits are usually seen in the preserved upper flow regime deposits (Collinson and Thompson, 1982). The herringbone cross-bedding, indicating possible antidunes (however, herringbones are a common tidal feature), and the wavy bedding encountered locally in the Daspoort Formation could be associated with higher flow rates (Alam et al., 1982). Herringbone cross-bedding can be indicative of reversing tidal currents, but oscillary wave-generated flow conditions can also be responsible for the occurrence of these bedding features (Clifton et al., 1971). Planar cross-bedding can also form antidune-like features, in fluvial channels (Selley, 1968; Alam et al., 1982). The variety of sedimentary ripple marks and cross lamination, especially found in the central Daspoort basin, together with the oscillatory genesis of the bedding planes are, according to Allen (1981), very characteristic with low-energy wave environments. The western and central Daspoort basin shares these diagnostic features; which can be linked to a gently shelving marine beach or a lake margin (de Raaf et al., 1977; Allen, 1981).

Physical characteristics such as channel-fills are common throughout the Daspoort Formation. These can be found in fluvial dominated environments and as sub-marine channels within an epeiric sea where streams debouch or fans extends their lobes (Mississippi-like) into fan-deltas; channels also occur on tidal flats (Parizot et al., 2005). Epeiric seas can also have strong currents due to their shallow depths and large lateral extents (Eriksson et al., 2002). These tides can therefore easily erode and fill channels. It is thus accepted that channel-fills are ambiguous parameters, when only considering their pure physicality and not a facies model, in deciding between an alluvial-fluvial-lacustrine environment and an epeiric sea.

The Strubenkop mudrocks are interpreted with an ambiguous point of view. Though poorly studied, this formation could resemble a lacustrine deposit (Eriksson et al., 2005) or a more widely accepted alternative marine environment (e.g., Eriksson et al., 2001 and references therein). If there was a transition to the latter (if a lacustrine basin existed) a transgression is needed flooding the basin which should be the result of a large global eustatic event or a local tectonic/thermal event providing the necessary subsidence (Eriksson, 2010). According to Figure 4.5 below, the Strubenkop Formation probably formed part of an initially non-marine transgressive system tract in a shallow lacustrine environment. Leading up to Strubenkop times, the sea level was increasing and this trend was continued with Daspoort sedimentation and reversed to a regressive tract during post-Magaliesberg epeiric times. The shoreline lowered, exposing a lacustrine and fan system, developing just prior to the Bushveld igneous event (Eriksson et al., 2001).

The Strubenkop and Silverton Formations comprise of predominantly mudrocks which supports a highstand system tract, but the latter resembles a transgressive system tract according to Eriksson et al. (2004). The Strubenkop mudrocks may, in part, have included low density turbidites concordant with incised valley fills of fluvial/estuarine strata deeper in the basin at the time, supporting a lowstand system tract prior to transgression. The thinly bedded basal shale of the Silverton Formation is commonly referred to as a condensed section. These are often black shale of a couple of meters thickness. Localised debris-flow deposits in the west are overlain by widespread mudrocks which progressively deepen upwards as successively younger parasequences step further landward. This is synonymous with a transgressive system tract where base level rise at the shoreline as the epeiric sea fills the basin (Eriksson et al., 2002). The Silverton Formation has volcanic units though lithofacies and general observations concur with a shallow marine environment. Volcanism could have resulted from continuous subsidence in the Pretoria basin which in turn sparked warping between the eastern and western units of the Silverton Formation, especially the western boundary of the eastern basin region. Bearing in mind that volcanism is usually a short-lived event, the epeiric sea was a long-lived phenomenon controlled by more regional tectonic-thermal eustatic influences.

4.4.1 Sequence Stratigraphy

The two distinctive units of the Daspoort Formation can be classified as system tracts rather than sequences, because they don't show any bounding subaerial nonconformities (cf., Eriksson et al., 2005). The upper coarser grained unit and lower finer grained unit are non-marine system tracts similar to high and low accommodation system tracts described by Dahle et al. (1997), Boyd et al. (1999) and Zaitlin et al. (2000).

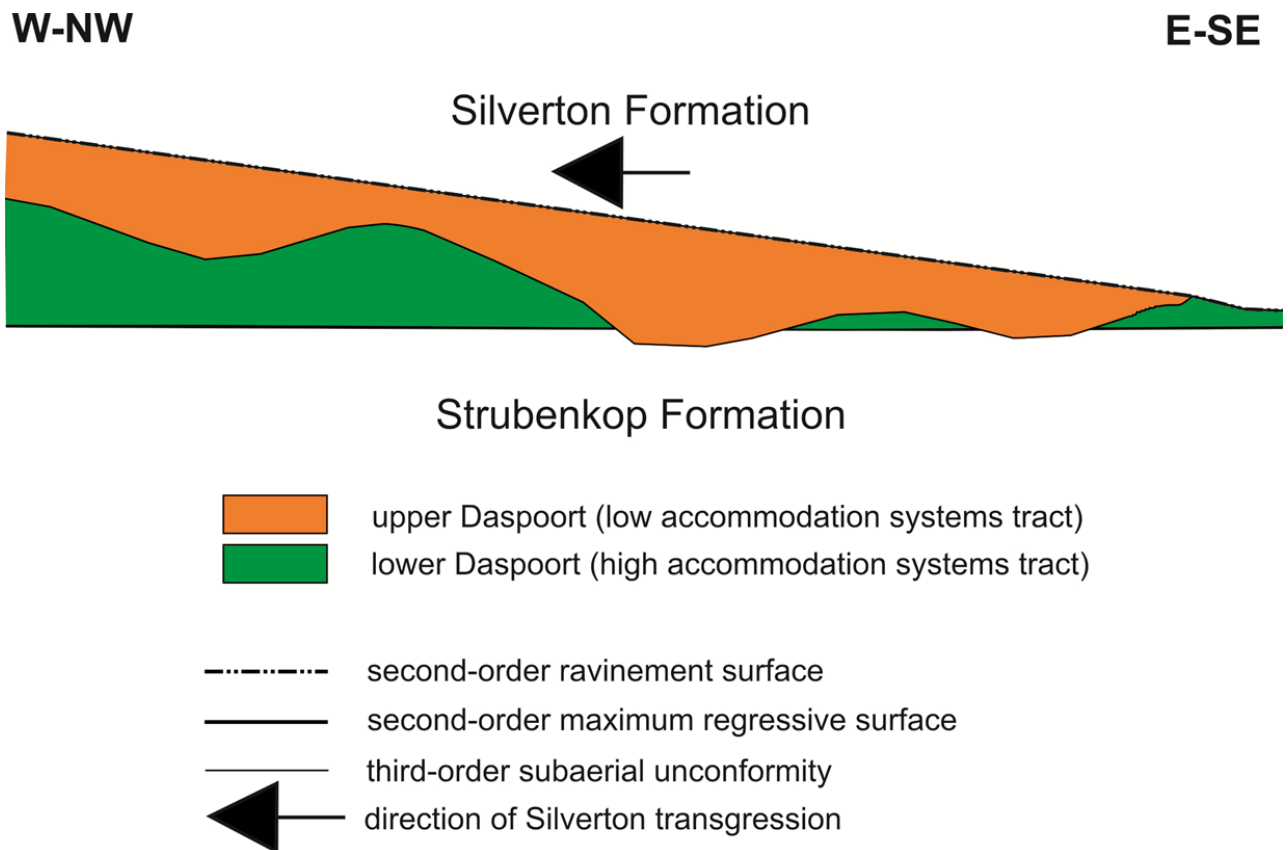

Figure 4.5: A conceptual diagram showing the two third-order systems tracts of the Daspoort Formation. Drawing is not to scale. The high accommodation systems tract (lower Daspoort) includes the sandstone and mudrock-ironstone facies associations, and is interpreted to have formed during a time of relatively high rates of base level rise. The low accommodation systems tract (upper Daspoort) includes the pebbly sandstone facies association, and is interpreted to have formed during a time of relatively low rates of base level rise. The two systems tracts are separated by a subaerial unconformity (third-order base level fall) that locally incises through the entire lower Daspoort deposits. Modified after Eriksson et al., 2004.

Low accommodation conditions in non-marine systems result in incised valley-fill type stratigraphy which is dominated by successive channel-fills and generally coarser sediments which indicate the absence of floodplain aggradation (Eriksson et al., 2004, 2005, and references therein). This facies set is abundant in the western basin and upper Daspoort Formation. Like lowstand system tracts (Boyd et al., 1999), the progradational nature of the deposition could be influenced by the underlying incised valley topography (Eriksson et al., 2005 and references therein). The high accommodation conditions of the

lower Daspoort Formation (and more characteristic of the E of the basin) were probably the result of higher rates of base level rise distally. These deposits in the east of the basin have a thicker- and finer grained stratigraphic architecture which corresponds possibly to highstand and transgressive systems tracts (Figure 1.3) (cf., Eriksson et al., 2005). This vertical change (and also E to W change) is prominent throughout the Daspoort basin with a possible lowstand type situation developed into a TST nearing Silverton times.

The finer sediments of the lower Daspoort regime are attributed to lower energy environments from the east of the basin where either shallow basinal or lacustrine deposits occurred compared to the alluvial palaeoenvironment envisaged for the upper (and western) Daspoort Formation. The finer sediments are generally encountered in the east of the Daspoort basin – where the mudrock and ironstone facies are also most abundant.

The coarser upper unit of the Daspoort sandstones have pebbles developed in seemingly high energy pulses in alluvial channels, amalgamating and braiding. The depositional tempo excluded the possibility of accumulation of sediments on a floodplain. The erosive base of the pebbly sandstone facies is described as a third-order subaerial unconformity because it, according to Eriksson et al., (2004), separates the lower Daspoort unit (sandstone-, mudrock-, ironstone facies) from the upper pebbly unit. These authors also found that this surface cuts into the lower unit of the Daspoort Formation, therefore reworking the second order maximum regressive surface below at the Daspoort-Strubenkop contact. The two units, the bottom one finer grained than the upper unit, are defined as system tracts in a non-marine environment indicating high (coarse grained, high energy) and low (fine grained, low energy) accommodation system tracts as discussed by Dahle et al. (1997), Boyd et al. (1999) and Zaitlin et al. (2000) (discussion in Eriksson et al., 2004). The low accommodation succession in the Daspoort Formation (upper unit) displays an abundance of channel-fills associated with medium to coarse sediments, especially in the west. This indicates a progradational depositional setting during a possible low stand system tract (LST). Eriksson et al., (2004) explains that depositional settings where base level rise is accelerated are generally thicker successions where high accommodation trends dominate. This is indicative of transgressive and highstand systems tracts (Figure 4.7). Eriksson et al., (2004) assigned the finer grained facies associations to a third-order high accommodation systems tract. Low energy regimes associated with elevated water levels and finer sediments is believed to have prevailed in the Daspoort basin during this time. It makes sense to infer that this quiescent unit is associated with lacustrine and/or floodplain deposits associated with a shallow eastern marine basin, whereas the upper unit tends to display proximal aggradation in the west (proximally) and eastwards progradation in a fluvial system.

The Magaliesberg Formation had an interpreted aggraded deposition during highstand conditions. This feature could be responsible for the excellent preservation of the microbial mat-related structures which formed in the ever changing Magaliesberg tidal environment (Eriksson et al., 2005). The high accommodation systems tract associated with the lower Daspoort unit follows a second-order LST (Eriksson et al., 2005). The lower unit can be associated with a TST and subsequent HST (Table 7),

because it was terminated by a short-lived, third-order stage of base level fall which was responsible for the third-order subaerial unconformity separating upper from lower Daspoort systems tracts (Eriksson et al., 2005). The upper unit (much thinner than the lower unit) can be compared to a LST, due to its low accommodation ability and lack of floodplain aggradation. This unit is overlain by the transgressive Silverton epeiric marine facies (Eriksson et al., 2005). Another envelope (2nd order transgression) of energy surge (wave and tidal ravinement surfaces) related to lower Silverton transgression probably partly destroyed MRS in the upper Daspoort succession or prohibited the evolution thereof at the time (Eriksson et al., 2012a). For the eastern Daspoort basin Figure 4.6 explains the possible influences tectonics and sedimentation may have on shoreline architecture (cf., Catuneanu, 2006). Ample accommodation space is provided in a marine environment where fine material can accumulate during a transgressive systems tract. As the Daspoort basin filled up in the east, a gradual rise in base-level occurred throughout the basin. The tectonic tilt towards the eastern basin described by Eriksson et al. (2005) would have contributed to increased accommodation space, a rise in relative sea level and a shift in shoreline relative to its datum and therefore it is suggested that a transgression took place (Figure 4.7 and Figure 4.8).

Fluvial systems in the western Daspoort basin didn't form deltas as they prograde eastwards. It seems that the rivers prograde gradually into a 'central' basin where any evidence for braid-deltas were obscured through post-Transvaal deposits and intrusions. Locally, the river systems display braid-delta characteristics, but once these channels debouched into the postulated shallow marine environment where tidal processes were more common than wave- and deltaic associated influences. This epeiric sea would have developed, due to its shallow depth (see Regional Characteristics), tide dominated rather than wave dominated architectural elements. Storm dominated settings appear not to have been a major factor as ripple data don't support ripples formed by wind in the western basin of the Daspoort succession. What is debatable however, is the immature sediments in this area which could not have formed and been sorted by a storm dominated shelf environment. Constant reworking of sediments at the shoreface where waves and tidal energy prevail cannot logically be responsible for poor sorting and mineral reworking as we see in the coarse clastic sediments in the western basin. It is envisaged that these transported sediments originated in a more proximal environment, closer to its source. Therefore it is believed that there was no or little chance for wave and tidal energies to influence the sedimentation in the west of the preserved basin.

The poorly preserved evidence for palaeoenvironmental interaction with epeiric conditions in the Daspoort basin makes delineation of shorelines across the basin a difficult task. It is believed that interplay did exist between the fluvial and marine systems due to the continuous energy variations seen in the central and eastern basin. It is here where the thickest units occur and is believed that the basin started filling up from the east. Eriksson et al. (2004) describe their depositional model in detail where second- and third-order system tracts are discussed. The low gradient shoreface setting on a shelf in a intracratonic basin allows for lagoon-like or estuaries to form (Table 7 and Figure 4.6). The preservation of the facies assemblage found in these settings are dependent on the rate of base level rise and wind/wave energy (Figure 4.7).

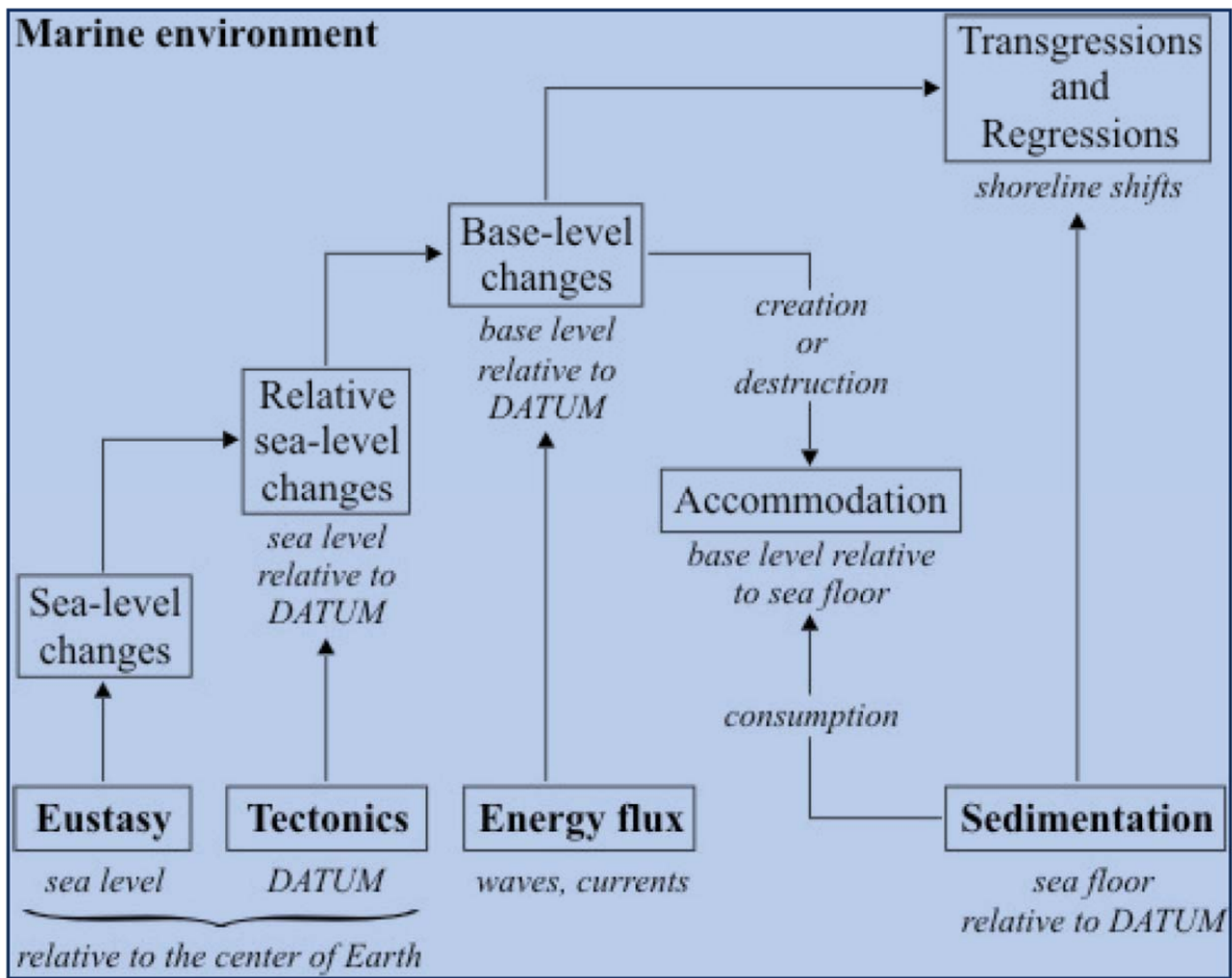

Figure 4.6: Controls on accommodation and shoreline shifts in a marine environment. The 'DATUM' is a reference horizon, independent of sedimentation, which monitors tectonic motions (subsidence, uplift) relative to the centre of the Earth. Modified after Catuneanu (2006).

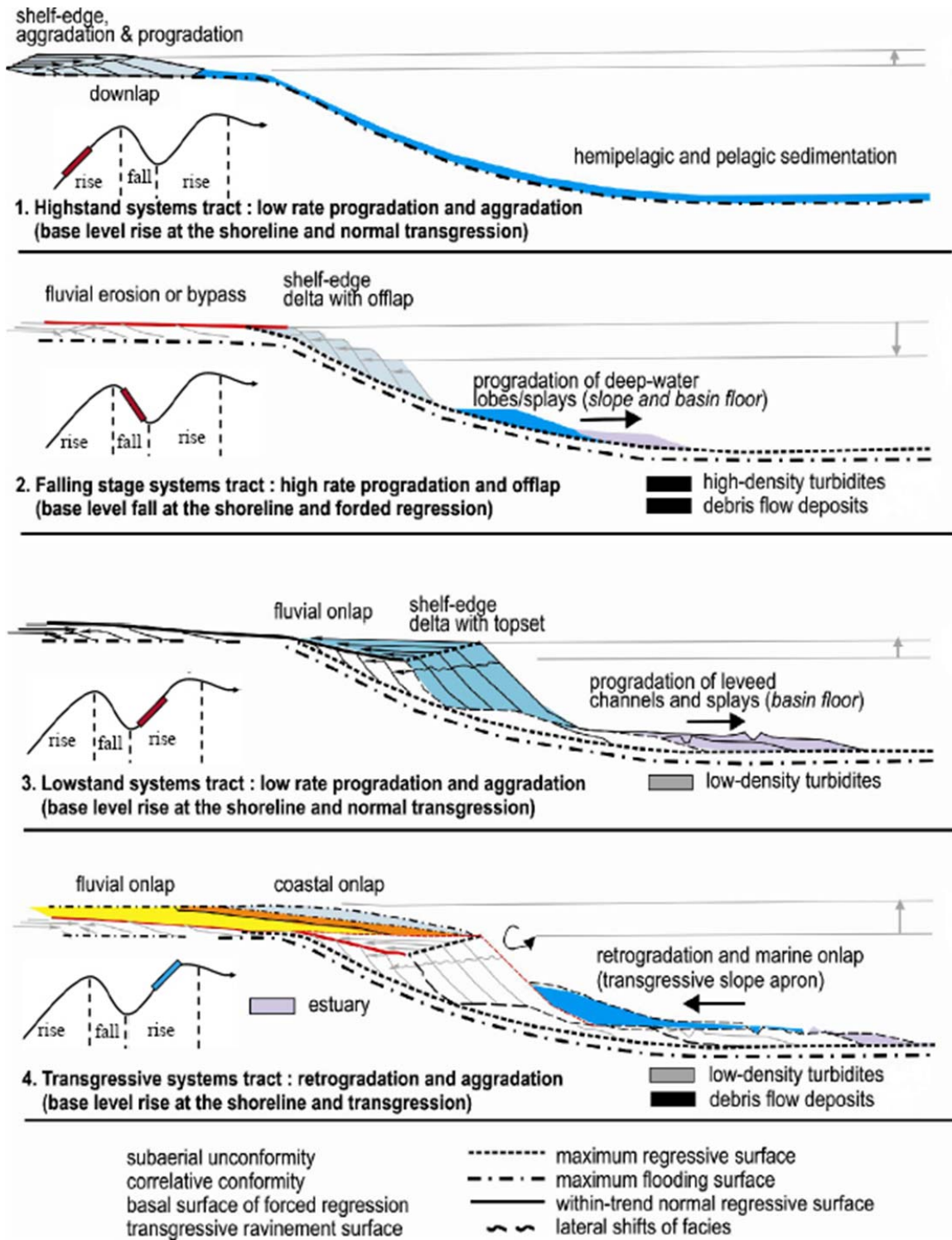

Figure 4.7: Regional architecture of depositional systems, systems tracts and sequence stratigraphic surfaces (from Catuneanu, 2006). The systems tract nomenclature follows the scheme of Hunt and Tucker (1992). Systems tracts are defined by strata stacking patterns and bounding surfaces, with an inferred timing relative to the reference curve of base-level changes at the shoreline. Acquired from Atlas of microbial mat features preserved within the clastic rock record, Schieber, J., Bose, P.K., Eriksson, P.G., Banerjee, S., Sarkar, S., Altermann, W., and Catuneanu, O., (Eds.), Elsevier, p. 276 – 283. (2007).

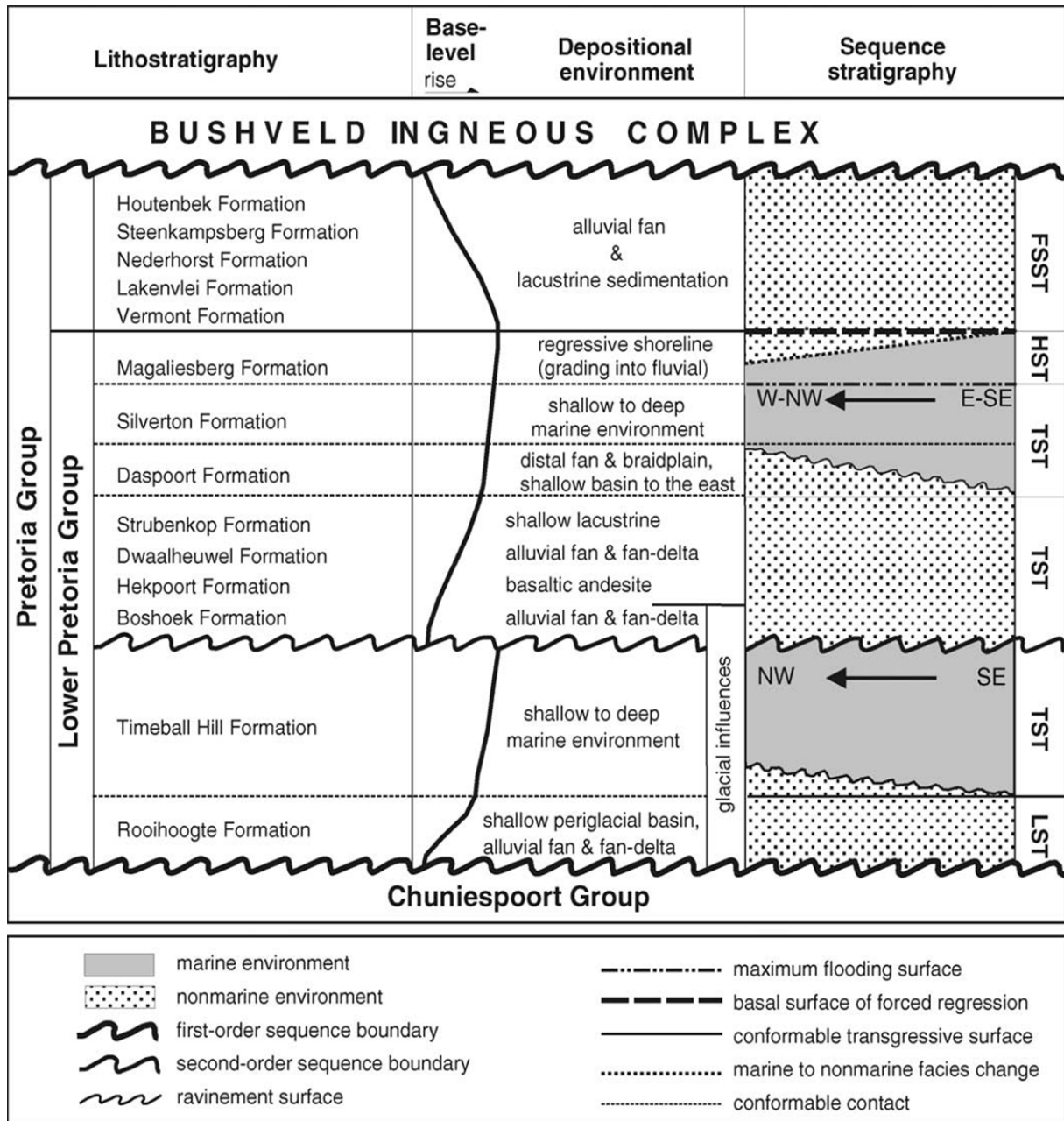
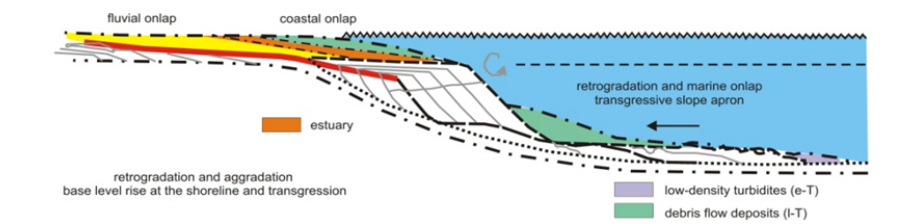
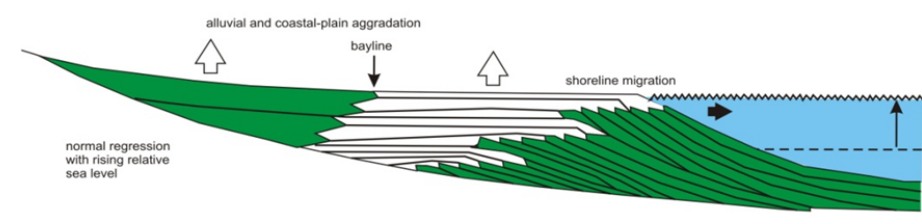
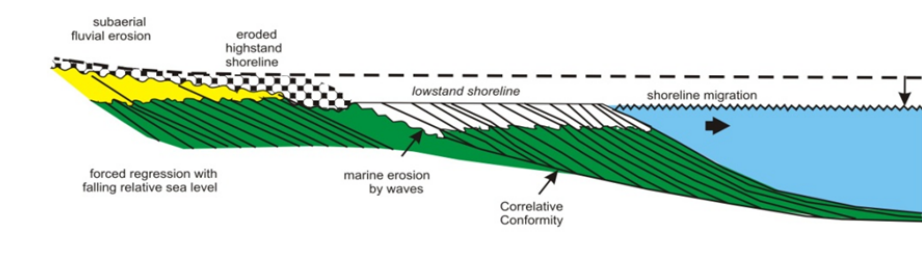

Figure 4.8: Sequence stratigraphic model for the Pretoria Group; note that this figure is not drawn to scale, but that the vertical axis suggests both time and thickness. Arrows in the column headed “sequence stratigraphy” indicate directions of shoreline transgression. The Daspoort Formation, according to field data, has an indicated E-W transgression (basin fill) orientation. Abbreviations used: LST = 2nd order lowstand systems tract; TST = 2nd order transgressive systems tract; HST = 2nd order highstand systems tract; FSST = 2nd order falling stage systems tract. Modified after Catuneanu and Eriksson (1999); in Eriksson et al., 2005.

Table 7: System tracts possibly associated with the Daspoort Formation in the Pretoria Group. Modified after Hunter and Tucker (1992); Catuneanu (2001); in Schieber, (2004).

<p style="text-align: center;">Basin Types</p> <p>Shoreline shifts</p>	<p>Low-gradient ('shelf') settings (continental shelves, filled foreland basins, intracratonic basins)</p>	<p>High-gradient ('ramp') settings (continental slopes, underfilled forelands, rift and strike-slip basins)</p>
<p>Transgressions</p> 	<p>Estuaries are likely to form. The preservation of estuarine facies is a function of the rates of base-level rise and wind/wave energy.</p>	<p>Estuaries are unlikely to form, due to the steep topography, higher fluvial energy, wave erosion, and slope instability.</p>
<p>Normal Regressions</p> 	<p>Deltas have diagnostic topsets, as a result of aggradation in the delta plains.</p> <p>Fluvial aggradation extends over a relatively large distance upstream (inconspicuous onlap onto the subaerial unconformity at lowstand).</p>	<p>Fluvial aggradation is restricted to a relatively small area adjacent to the shoreline (pronounced onlap). Fluvial strata have low preservation potential.</p>
<p>Forced Regressions</p> 	<p>Deltas have diagnostic offlapping geometries (delta plain erosion or bypass).</p> <p>The regressive surface of marine erosion forms in the lower shoreface in wave-dominated settings.</p>	<p>No erosion in the lower shoreface, as the sea floor is already steeper than the shoreface equilibrium profile.</p>

4.5 Palaeocurrents

Palaeocurrent data and relative age comparisons have been used to compare the Pretoria Group and the Segwagwa Group, an inferred equivalent unit in Botswana. According to Master (1993) detrital zircons in the Transvaal Supergroup (Pretoria Group) and the Segwagwa Group suggest a common source area for sedimentary rocks from the respective groups. Based on this and dominant northerly directed palaeocurrents for both basins (Kanye basin in Botswana; Transvaal basin in South Africa) he concludes that there existed a possible palaeogeomorphological high to the west of the Zimbabwe craton.

Mapoe et al. (2006a) concurs with the general N, NW and NE palaeocurrent directions for Pretoria-Segwagwa Group, but suggest that the Zimbabwe craton or sedimentary terranes undergoing orogenesis northwest of the Kaapvaal craton could have provided a Palaeoproterozoic source terrain.

The polymodal palaeocurrent trends in the eastern part of the Daspoort basin, compared to the western part, could be attributed to change in sea level and/or shallow marine conditions; waves and wind action at the shoreface, as the basin started to fill up, may have caused a variety of palaeo-directions. Comparing with Eriksson et al. (2005) the directional patterns observed here are similar to those in their described mudstone-ironstone facies association which are commonly best preserved with interbedded sandstone facies. This, together with a general east – west coarsening of the Daspoort sandstones and the seemingly pyritic nature of the sandstones in the east, suggests that the Daspoort fluvial system progressed into a shallow marine basin towards the east and southeast (cf., Eriksson et al., 2005).

It is believed that the fluvial deposition of Daspoort sediments coincided with the gradual epeiric transgression of the Silverton Formation marine environment. Highstand conditions followed (Catuneanu and Eriksson, 1999; Eriksson et al., 2002a), once the transgressive advance had occurred, predominantly in an E-W direction. The Hekpoort Formation volcanic rifting in the Pretoria Group has a similar strike, implying that it may have been a controlling factor of the Daspoort-Silverton basin development along this E-W orientation (Eriksson et al., 2005) with subordinate S-N and SW-NE gradients.

It is clear from preserved evidence for a tidal influence, that the rate of western-derived fluvial sedimentation of sandstones facies assemblages from the Daspoort Formation was gradually overcome by the Silverton epeiric basin subsidence rates as water level rose with the transgressive advance from east to west (Eriksson et al., 2005).

4.6 Previous work

Button (1973) noted a 70 m thick mature sandstone body with subordinate interlayered ironstone characterising the Daspoort Formation near Mokopane (Potgietersrus). He also compared the increase in thickness in the south of the basin (± 120 m) to that in the north (± 12 m), with the increase of maturity.

The isopach map of Eriksson et al. (1993) with added thickness data from Key (1983), Engelbrecht et al. (1986) and Hartzer (1989) can be interpreted as having a sheet-like character, but Schreiber (1991) and Van der Neut (1990) suggested a more wedge-like nature for the Daspoort sandstones. The thickest areas are in Botswana and Mokopane (Eriksson et al., 1993). Thinner outcrops are found in Pretoria and in the Lydenburg area. Eriksson et al. (1993) illustrate a thin belt stretching from the latter region to Pretoria and from Thabazimbi to Pretoria. The thick sand bodies are associated with the sheet-like structure of the Daspoort sandstones whereas the mudrocks account for the thicker units at Mokopane and Botswana (Eriksson et al., 1993). According to Eriksson et al. (op. cit.) the thinning in the Pretoria region is associated with the exclusive development of the pebbly sandstones there, but other areas containing this facies are noted further westward and in the far southeast of the basin where outcrop thickness easily exceeds the Pretoria thickness; however there could be a relationship between the thin Pretoria belt and the equally thin mudrock and ironstone facies beds in the northeast of the basin.

According to Schreiber (1991) palaeocurrents in the Pretoria Group's eastern regions, are largely westerly to south-westerly. The above-mentioned spread of palaeocurrent directions can also be characteristic of a shallow marine depositional environment or a sign of a regressive shoreline (Schreiber, 1991). Elliot (1986) believes that the planar-bedded, mature sandstones (such as typify the Daspoort) are found in delta front environments which are characterised by interactive fluvial and wave action and related to shallow marine wave processes near the shoreline (cited in Schreiber, 1991).

Limited measured palaeocurrents in the western regions by Eriksson et al. (1993) show transport directions to the south, southwest, northeast and further westwards show northerly trends, and at Thabazimbi, trends to the east.

A variety of different palaeocurrent directions was obtained in the southern parts of the basin. These correspond to Van der Neut's (1990) and Schreiber's (1991) measurements. Southeast of Pretoria Van der Neut measured predominantly south to south-eastern transport directions. His measurements are depicted in Figure 7.19 and Figure 7.20. In the far south-eastern region of the basin, near Machadodorp, south-western trends are seen while further north from there Schreiber (1991) noted westerly to north-westerly measurements. Further north Eriksson et al. (1993) obtained east- and west-directed transport directions. Ironstone and mudrock gave no suitable measurements

while palaeocurrent data in pebbly sandstones in the Pretoria area were predominantly orientated towards the south and southeast (Eriksson et al., 1993).

Van der Neut (1990) stated that the central Pretoria part of the basin shows a predominant northerly transport direction with a bimodal west-northwest to south-southeast component present too. He also noted a variety of palaeocurrent directions for the study area just east of Pretoria.

Van der Neut (1990) also measured channel-fill directions and herringbone cross-bedding in the Pretoria-Delmas-Bronkhorstpruit area. He found that the dominant transport direction for the herringbone cross-bedding had a northeast-southwest and east-west orientation.

The palaeocurrent data from pebbly sandstones, especially from the Pretoria region, show weak bimodal trends with a predominant southerly orientation (Eriksson et al., 2005). Polymodal data in the east and southeast were obtained compared to the unimodal palaeocurrent directions in the west, especially for the sandstone facies, both horizontally laminated and ripple cross bedded types therein (Eriksson et al., 2005).

4.7 Microbial mat features

For at least 3.2 Ga microbial mats influenced sedimentary processes and the effect on sequence architecture is evident for Proterozoic successions (Sarkar et al., 2005; Schieber et al., 2007) such as the Magaliesberg and Daspoort Formations (e.g., Eriksson et al., 2012). The Phanerozoic eon gave rise to physically larger organisms and their subsequent families at the cost of microbial activity. The little evidence left in the Daspoort Formation still gives us substantial information such as the increasing cohesiveness of the substrates by microbial mats during that time (cf., Schieber et al., 2007). The repeated change from high energy environments (massive sandstones) to calm, shallow marine conditions (microbial activity) in a sedimentary basin creates a clearer depositional cycle for the Daspoort-Silverton-Magaliesberg succession. Schieber et al. (2007) suggest that coastal to shoreface wave erosion could have been stronger in the Precambrian, thus preserving microbial mat structures within shelf systems, unlike today. The organic binding of sediments by microbial mats does increase the cohesiveness of the substrate (Schieber et al., 2007). This also gives rise to the genesis of other sedimentary structures which are indicative of syn-depositional microbial activity (Schieber et al., 2007).

The occurrence of microbial mats is indicative partly of the relative energy of the physical processes which prevailed during that time in a sedimentary basin. It is believed that coastal to shoreface wave erosion during Pretoria Group (Precambrian) times is the reason for well preserved microbial structures in shelf systems (cf., Schieber et al., 2007). Contrary to this, modern mats tend to occur in coastal to shoreface environments. Various types of microbial mats are found along different marine

margins. The margins are dependent on the sea level fluctuations of that time. Research on the Precambrian sequences reveals that transgressive system tracts (TST) are not always well developed (e.g., Sarkar et al., 2005). These sequences are commonly dominated by stacked system tracts of normal regressive deposits that may be separated by thin veneers of transgressive deposits, often reduced to transgressive lags, which are contrary to many a Phanerozoic sequence which include fully developed transgressive systems tracts consisting of all depositional systems from fluvial, to coastal and fully marine (Sarkar et al., 2005; Schieber et al., 2007 and references therein). The poor development of transgressive systems tracts within the Pretoria Group could be due to strong wave scouring in the upper shoreface during shoreline transgression (cf., Sarkar et al., 2005; Schieber et al., 2007). Analogously the inferred shallow gradient of the Daspoort basin in the east supports rapid transgressions, low sediment influx and the absence of well developed transgressive shale (cf., Schieber et al., 2007) above ravinement surfaces (unlike the western region). The growth of microbial mats below the fair-weather wave-base (in the shelf environment), which prevented deep-water current reworking of sediments by the organic binding of clastic particles, could explain the accumulation of regressive deposits though (s)low sediment supply prevailed (cf., Schieber et al., 2007).

The most significant microbial structures encountered were: “Old Elephant Skin” (OES); petee ridges and/or sand cracks. The OES feature was the most common in all of the Daspoort sandstones. The characteristic mat evolution structures found; petee ridges, OES, *Kinneyia* structures and gas domes are evident of mat growth and the latter of mat decay evolutionary stages. A suggested palaeoenvironment is an intertidal to subtidal marine setting where biofilms separated thin sandstone beds subject to soft sediment loading processes. Petee ridges are believed to form in a braid –deltaic – tidally controlled epeiric marine coastline. This is supported by the Magaliesberg Formation model (e.g., Parizot et al., 2005).

Ideas on genesis (after Schieber et al., 2007 and references therein): *The evidence for soft sediment deformation and for the source of petee ridge sand in the bed immediately underlying the mat supports either a synaeresis-like origin (due to overlying beds’ pressure causing post-burial movement of sand into cracks in the mat) for these features, or that the liquefied sand moved laterally into the cracks within the microbial mat from beneath, under pressure from overstanding water or even (spring) tidal oscillation. In all cases, inferred crack-filling is from the unconsolidated sand bed beneath the mat. In the case of the few shoreface examples of petees, a synaeresis-style origin would appear to be the most logical. Some dense networks of Daspoort petees appear to bunched up against each other, suggesting that the mat allowing ridge formation was also subject to (partial) detachment and wrinkling (see Figure 4(c)-9 in Chapter 4). Petees may also form under mat growth conditions, as well as due to mat destruction. In the former case, updoming and even rupturing of the mat due to wind, current action and gas development will allow petee ridge formation; petee genesis*

during mat destruction is related to a high level of mat-cracking and desiccation and forms part of a genetic continuum of petee origins.

Sand cracks forms in a similar environment. Based on the ideas on genesis of (Schieber et al., 2007), these features and the petees that result later are interpreted as reflecting filling of cracks within microbial mats growing/desiccating on a sandy surface from above, by other sands brought in either by aqueous currents or aeolian action. If the mat then decays or is eroded away, these crack-fills will remain behind as positive ridges, with the same plan-form geometry as the original microbial shrinkage structure. Alternatively the mats, with their sandy crack-fills may become buried beneath later sediments, and then the mat will, in time, decay and disappear and the crack-fill ridges will become flattened beneath the weight of overlying beds, which is commonly seen in ancient examples, including some of those shown here. It is distinctly possible that crack-fill and immediately overlying sandstone bed will have the same composition, reflecting a single sedimentation event, laid down on top of the original, cracked mat. This would appear to be relatively common.

Microbial mat-related structures (MRS) are not predominant in the Daspoort Formation as it was studied in isolation in this thesis. MRS (described by Eriksson et al., 2010) is commonly found in epicratonic epeiric marine clastic basins of the Proterozoic period (cf. Eriksson et al., 2004). The Magaliesberg Formation epeiric environment lent itself to the development of pervasive shallow marine sandy and muddy deposits. These developed through changing environments from shelf to supralittoral, where the latter facies contains good examples of preserved MRS (Eriksson et al., 2010). The poorer preservation of MRS within the Daspoort Formation could be indicative of constantly changing environments within the basin at the time. These environments can, to a large extent, be traced on an East-West striking chronological spur of events; from the fluvial systems and braid plains in the west to the shallow marine conditions in the east, a multitude of sedimentary processes brought along changing environments, notwithstanding the influence of tectonic and regional metamorphism on MRS in the Daspoort basin. According to Eriksson et al. (2004) the Proterozoic littoral sandstones have good preservation potential for MRS. Bioturbation which can be detrimental to microbial mat development is limited in the Daspoort Formation, but the scarce occurrences of MRS withstood other physical and chemical weathering factors. Unfortunately the isolated occurrences of MRS in the Daspoort Formation can't clarify the relationship between basin parameters such as sediment supply, slope gradients and the type of MRS likely to form in such areas as intracratonic basins. MRS distribution and genetic environments in the Pretoria Group's Magaliesberg – and Daspoort Formations should be integrated to establish a framework on which these structures can be identified within a specific environment. This would encourage positive palaeoenvironment interpretation within environments such as the Daspoort and Magaliesberg Formations on a regional scale. This would further serve the study of similar environments, their respective facies parameters and international clarification on depositional environments where MRS forms part of the architecture.

4.8 Gabon fossils and the Great oxidation event (GOE)

In the section on Regional Characteristics the subject of unicellular and multi-cellular organisms was raised for Daspoort times (~2.1Ga). It is widely believed that the Earth was still in a primitive stage of biological development which couldn't account for complex structures such as eukaryotes/multi-cellular organisms (see Figure 4.9 for chronological evolution of life on Earth). Eukaryotes refer to organisms living in colonies with a membrane-bound nucleus that represent a complex form of bacteria. The big question is whether the new West-African specimens (Albani et al., 2010) truly represent large organisms growing in a co-ordinated manner, or are merely a record of the remains of aggregations of unicellular bacteria? The authors of the relevant paper in *Nature* (Albani et al., 2010) suggest that analysis of the fossils' three-dimensional structure using X-ray microtomography leans towards the former explanation. The fossils would have existed during a period in Earth's history that came after the so-called Great Oxidation Event (ca. 2.4-2.3 Ga; e.g. Holland, 2009), when free oxygen concentrations in the atmosphere rose rapidly. There was another oxygen surge that occurred about half a billion years ago which co-incided with the Cambrian Explosion - the huge spurt in evolution that established all the major animal groupings. "The evolution of the Gabon macrofossils, representing an early step toward large-sized multicellularity, may have become possible by the first boost in oxygen," Dr El Albani and colleagues said in a statement, "whereas the Cambrian Explosion could have been fuelled by the second. Why it took 1.5 billion years for the multi-cellular organisms to take over is currently one of the great unsolved mysteries in the history of the biosphere (Albani et al., 2010)." These multi-cellular organisms are way ahead of their time if an age slightly younger than the GOE is attributed to them. For Daspoort times (ca. 2.2- 2.1 Ga) the ancient rock record doesn't support multi-cellular organisms, but only traces of unicellular organisms. Even though the earth experienced much higher oxygen levels after the GOE (post 2.4 Ga), it was still littered with greenhouse gases (Donoghue et al., 2010).

MRS is known well before this surge in Earth's oxygen levels, even up to the time of the Isua succession in Greenland (3.6 Ga). The GOE of the Palaeoproterozoic affected the Earth's biosphere, hydrosphere, atmosphere and chemical nature of the rock record (Eriksson, 2012). This was one of the Earth's greatest events. Subsequently this affected the evolution of life, or in this case MRS. These structures are believed to have been photosynthetic and the added oxygen probably enhanced the development of MRS and associated organisms during the Proterozoic.

Eriksson et al. (2012) tried to establish a link between preserved microbial mat features and the depositional environments of their associated clastic sediments. The Daspoort Formation sandstones, based on Eriksson et al. (1993), reflect an inferred second-order transgressive

systems tract in a sequence stratigraphic framework (Eriksson et al., 2012). Unfortunately wave action on the shoreface/ravinement surface in tidal environments is thought to have destroyed much of the remaining microbial mat-related features. These features would have been constructed by cyanobacteria living in the intertidal and supratidal environments of the Daspoort Formation (Eriksson et al., 2012). Cyanobacteria are renowned for being prolific mat architects (see Schieber et al., 2007a, c). The preserved microbial mat features in the Magaliesberg Formation are believed to have been protected from reworking during a second-order highstand systems tract where episodic braided fluvial systems were feeding sediments into a tidally dominated epeiric coastline setting (Eriksson et al., 2012).

The cultivation of well developed modern mats requires weeks of non-burial, thus indicating that these structures need an environment where they have sufficient time to develop (Eriksson et al., 2012). Therefore, periodic or episodic clastic sedimentation patterns would suit this inferred environment for microbial mats to grow (Eriksson et al., 2009) instead of continuous high energy deposition and reworking/interference experienced in the lower shoreface. It is necessary to mention that most preserved microbial mat features in the Pretoria Group have been found in inferred shallow epeiric settings (particularly the Magaliesberg Formation).

The facies model assigned for inferred microbial mat forming environments is open for debate. Eriksson et al. (2010) postulate facies specific environments for unique mat-related architectural assemblages, but Schieber (et al., 2007a, c) support a non-facies specific genetic environment model. The Daspoort Formation mat-related examples fail to support the former argument as only sparse examples were found. These examples showed no comparison whatsoever (see #2 – Gopane and Carolina localities). Apart from the inferred inter- and supratidal environments for microbial mat features, authors (e.g., Gerdes et al., 1985a, b, c) also envisage a hypersaline lagoon environment as being especially beneficial for MRS development.

The fluvial nature of the Daspoort Formation in the western basin, where only petee ridges were found, is thought to have been subordinate as a microbial mat related building environment compared to the 3 stages of mat building inferred from examples of MRS encountered in the east, which in itself reflects a postulated shallow marine environment. The west reflects an interface between the fluvial setting and shallow marine environment as the Daspoort basin filled. The mats found in the east are similar to what is found in the Magaliesberg Formation, both in physical appearance and inferred depositional environment. It is envisaged that the microbial mat related features of the Daspoort Formation preferred a shallow marine environment.

EVOLUTION OF LIFE AND SEDIMENTATION SYSTEMS

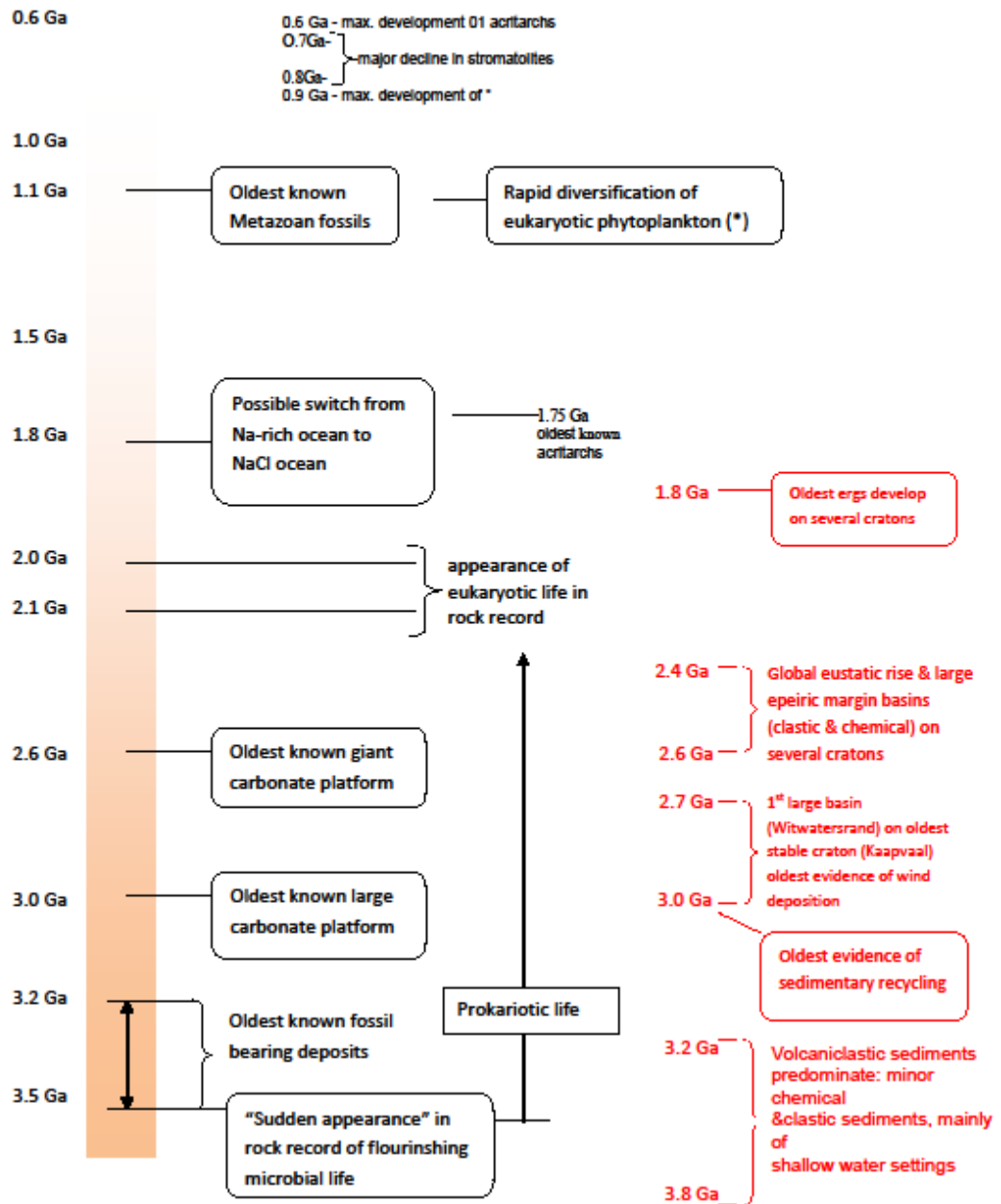

Figure 4.9: Adapted from Eriksson et al., 2004. Time chart showing a framework of Earth evolution within which Precambrian sedimentation systems developed. Three superevents (event-clusters) are postulated at c. 2.7 Ga, 2.2–1.8 Ga, and at 0.8–0.6 Ga, when significant changes occurred within evolution of Earth’s natural systems (Eriksson et al., 2004).

		Palaeoenvironment					Remarks
		Coastal	Shallow Sea/lake	Deep Sea/lake	Fluvial	Aeolian	
Mat-related features	Multi-directed, Palimpsest Ripples	█	█				Very shallow water to fair weather wave base. Most likely preserved in coastal to shallow sea/lake settings.
	Surface Ornamentation, Winkle Structures, "Elephant Skin" etc.	█	█	---	█	---	Judging from modern analogs these should be most common in coastal to shallow sea/lake settings. Potentially also associated with shallow water bodies on floodplains and coastal plains.
	Dormal, Convex-Up Features	█	█		---		Current energy required for accretion, thus more likely in shallow water settings. In high energy coastal settings poorer development due to erosion? May occur locally in fluvial channels with strongly episodic sediment transport.
	Petees & Ridges	█			---	---	Modern analogs suggest need for at least one of the following: strong shear forces, dessication, or gas expansion. Thus, coastal and other very shallow water environments most likely.
	Cements & Floating Grains	---	█	█			It helps if surface sediment maintains similar pore space chemistry for extended time periods (small sedimentation rates). Coastal to shallow/deep sea/lake should be most common environments.
	Sand Cracks Manchuriophycus etc.	█			█	---	Requires dessication, thus mainly expected in coastal and fluvial environments. Also possible in intermittently moist interdune depressions.
	Ripple Patches	█	---				Within fair weather wave base, need for powerful erosive events. Coastal setting most likely. Minor occurrences shallow offshore?
	Flip-Overs, Roll-Ups, Sand Chips	█	█	---	---	---	Strong currents/wave action needed. Most likely to form in coastal environments. Petering out into deeper water. Potentially also in moist terrestrial settings.
	Curved Sand Chips	█			█	---	Dessication and strong currents required. Most likely in terrestrial and coastal environments.
	Gas Domes & Kinneya	█	---		---		Shallow water favors formation of larger gas buildups. Likely environments are coastal and possibly shallow ponds on floodplains.

Figure 4.10: Mat-related features in sandstones according to Schieber et al., 2007. An inferred palaeoenvironment set is suggested for every feature. The yellow rows are the common mat-related features found in the Daspoort Formation.

4.9 Geochemistry

Boron, found in the mineral tourmaline, is an indicator of salinity (Eriksson et al., 1996) and is strongly associated with total clay content (Landergren, 1958) in a rock's composition. The most common source of boron in oceanic sedimentary basins is explosive andesitic volcanism, although it is mostly found in the shales of the Pretoria Group and on a local scale in the upper shale of the Daspoort Formation (Eriksson et al., 1996). These authors further explain the boron anomaly in the Daspoort Formation and boron traces in the sandstones (Figure 4.11 and Figure 4.12). The immediately overlying Silverton Formation with its higher palaeosalinity could also support a marine transgression at this level which gives rise to the increasing boron concentrations in these succeeding formations (Eriksson et al., 1996). These authors conclude that sedimentological evidence exists for the hypothesis of a marine incursion during the Daspoort-Silverton-Magaliesberg Formation deposition.

The discrimination of epeiric marine settings and closed intracratonic basins is especially difficult for Precambrian successions (Eriksson et al., 1996) due to poor preservation, low boron contents in epeiric seas, the absence of vegetation which could have absorbed heavy elements if present, and the aeolian removal of argillaceous sediment.

To unravel the anomalies discussed in the tourmalines found on a Daspoort inferred microbial mat specimen, one needs to establish the provenance of these needle-like minerals. In the Daspoort's case there is one, perhaps two, related varieties of tourmaline from the same parent rock. According to Krynine (1946) most tourmaline is found in re-worked, second-cycle rocks such as orthoquartzites.

Tourmaline can also shed light on the petrology of the source area, the diastrophic, tectonic, and climatic history of the source area and basin of sedimentation and establish palaeogeographic relations between ancient land and sea before and during deposition of the sediment (Krynine, 1946). This is all based on an assumption of marine conditions of that time. The external shape and internal morphology of the tourmalines are general parameters to determine the above-mentioned parameters (Krynine, 1946). Unfortunately the tourmalines found in the Daspoort Formation do not display overgrowths and are too small to derive any physical conclusions. In the Daspoort's case, the tourmalines occur on top of the sandstones in an inferred microbial mat proxy layer, and not inside the rock as part of the original composition. Therefore, no valid analyses can be made using Krynine's (1946) methods.

A mineralogical maturity index of heavy mineral assemblages of sandstones was proposed by Hubert (1962). This included zircon, tourmaline and rutile (ZTR index). The ZTR index is the percentage of the combined zircon, tourmaline and rutile grains among the transparent, non-micaceous detrital heavy minerals; this index could be over 90% for most orthoquartzite

sandstones (Hubert, 1962). Tourmaline and zircon are more common than rutile. The index was based on the concept of the 'maturing' of sandstones as they become more quartzose (Hubert, 1962). Tectonics was also a major controlling factor upon which this classification rests. The abundance of tourmaline and zircon compared to rutile in source terrains could explain this.

Quartzose sandstones are divided into 4 main groups; (1) first cycle orthoquartzites, (2) second cycle orthoquartzites, (3) quartzose graywackes and micaceous quartzites derived from micaceous detritus, (4) quartzose arkoses and feldspathic quartzites derived from feldspathic detritus (Hubert, 1962). Daspoort sandstones predominantly fall in the first 2 categories. No substantial evidence of a feldspathic detritus for the Daspoort rocks' genesis was noted; perhaps the only similarity could be postulated for the very coarse grained arkosic quartzites in west of the basin. According to Hubert (1962), quartzose sandstones derive from feldspathic detritus in two main ways:

- Deposition of quartzose arkoses in a site far removed from the source of the arkosic detritus;
- Modification of arkosic detritus in a locus of deposition of appreciable winnowing and washing, such as a shoreline of a lake, a beach, dune or an offshore bar.

The latter seems more applicable to the Daspoort Formation and the Pretoria Group as a whole when considering other parameters such as palaeocurrents, wave ripples and water depth.

First cycle orthoquartzites occur as thin sheets across an extensive area. These are often interbedded with chert-bearing, cyclically deposited carbonate rocks (Krynine, 1948).

Both sedimentary and boron data, though limited, support a hypothetical marine transgression into the Pretoria Group basin during Daspoort sedimentation. The variation in boron content in the Pretoria Group could indicate water level fluctuations, and not those of tides, but spanning longer periods (cf., Boggs, 1987) throughout the Pretoria Group deposition. This could infer a lacustrine rather than a marine environment. Though it seems that marine conditions in the Daspoort can't be ruled out, the fluvial and lacustrine settings seem to fit the geochemical picture better.

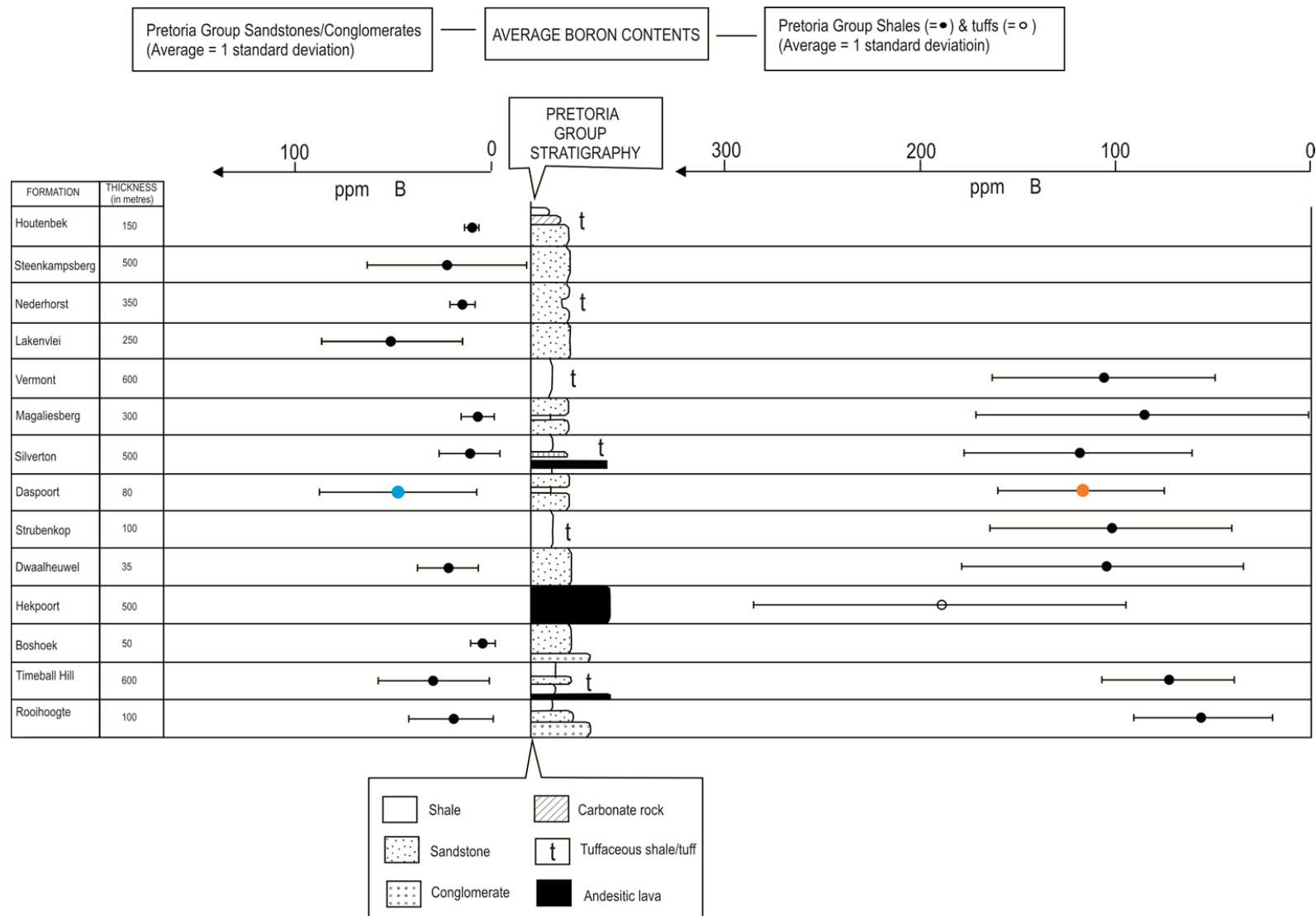

Figure 4.11: Average boron contents for the Pretoria Group formations. The Daspoort sandstones and shales are marked by blue and orange respectively. Standard deviation to the left of the lithology bar = (-1) and to the right = (+1). Modified after Schreiber 1992.

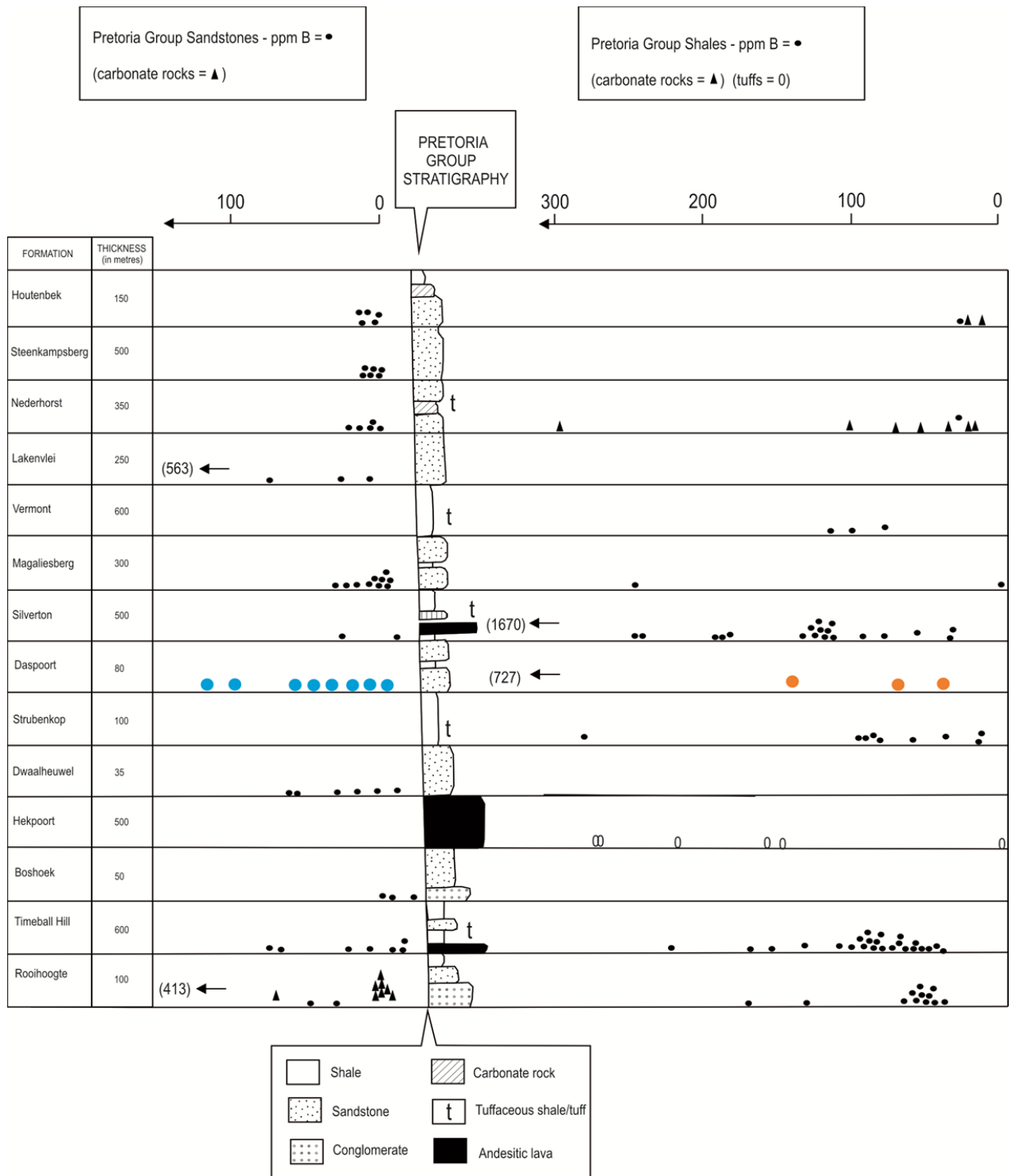

Figure 4.12: Pretoria Group Boron values versus stratigraphic height. Daspoort Formation sandstones and shales are in blue and orange respectively. Note that the values in brackets indicate extreme values which didn't fit the scale of the figure. Modified after Schreiber 1992.

4.10 Thickness relationships

Much thicker units were deposited in the west of the basin than the east, at least as determined from preserved outcrops (Figure 4.13). This could be attributed to the rate of sediment supply from predominantly WNW and ESE directions. Outcrops in the west have a steeper dip compared to the gentle to horizontal dip in the east. Outcrop thicknesses versus thicknesses acquired from boreholes (previous authors) creates false regional thickness interpretations, especially in the western basin. Here the outcrops are much thinner than those Daspoort Formation successions found in borehole data. The eastern basin do have pronounced vertical cliffs – near the eastern escarpment - representing the thick marine sandy units compared to the flat outcrop landscape in the western basin. No new outcrop information from the far south (Potchefstroom area) or the north (Thabazimbi, Mokopane) was considered into compiling Figure 4.13. A strong and rapidly thickness changing influence is interpreted for the western basin, with the thickest units found towards the outskirts of the basin. The opposite is true for the eastern basin, where a gradual thickness change is evident by the bigger isopach spacing (Figure 4.13). Boreholes intersecting the Daspoort Formation towards the central basin show thinner successions. It is unknown how the eastern and western basin's sediments converged and perhaps amalgamated in the central basin. Only borehole information in this area will be able to tell a better story.

Pebbly rock units are more common and thicker in the west. This supports the postulate of extensive fluvial action in the western region. The Pretoria basin also got shallower to the east, where thermal subsidence also became evident to Eriksson et al. (2004) and where a fluvial lacustrine environment was postulated (see Figure 4.13 map and Figure 4.25 in Appendices or in Eriksson et al., 1993). However, in later publications (e.g., Eriksson et al., 2001, 2006) an epeiric marine eastern Daspoort basin is envisaged.

The Daspoort basin was fed by sediments from all directions, but seemed to fill up towards the east where the thickest individual litho-units in the entire Daspoort Formation are seen. Although this basin was situated on the Kaapvaal Craton, Eriksson et al. (2004, their Fig. 8.4-8) suggested that a topographic tilt was directed towards the eastern sub-basin. It is here where fine sediments and ironstone facies accumulated which are seen in the lower unit of the Daspoort Formation. The western basin with its shallow channels of coarser grained sediments debouched into an epeiric sea, but it is unclear if these river systems reached the deeper regions of the eastern basin.

The compressed nature of the western basin's interpreted isopach map in conjunction with ripple mark information (Figure 4.14) is reflective of fluvial influx compared to the gentle isopach architecture seen in the eastern basin. The massive sandstones and various sedimentary features form homogenous outcrops in the eastern basin capped with marine induced mudrocks.

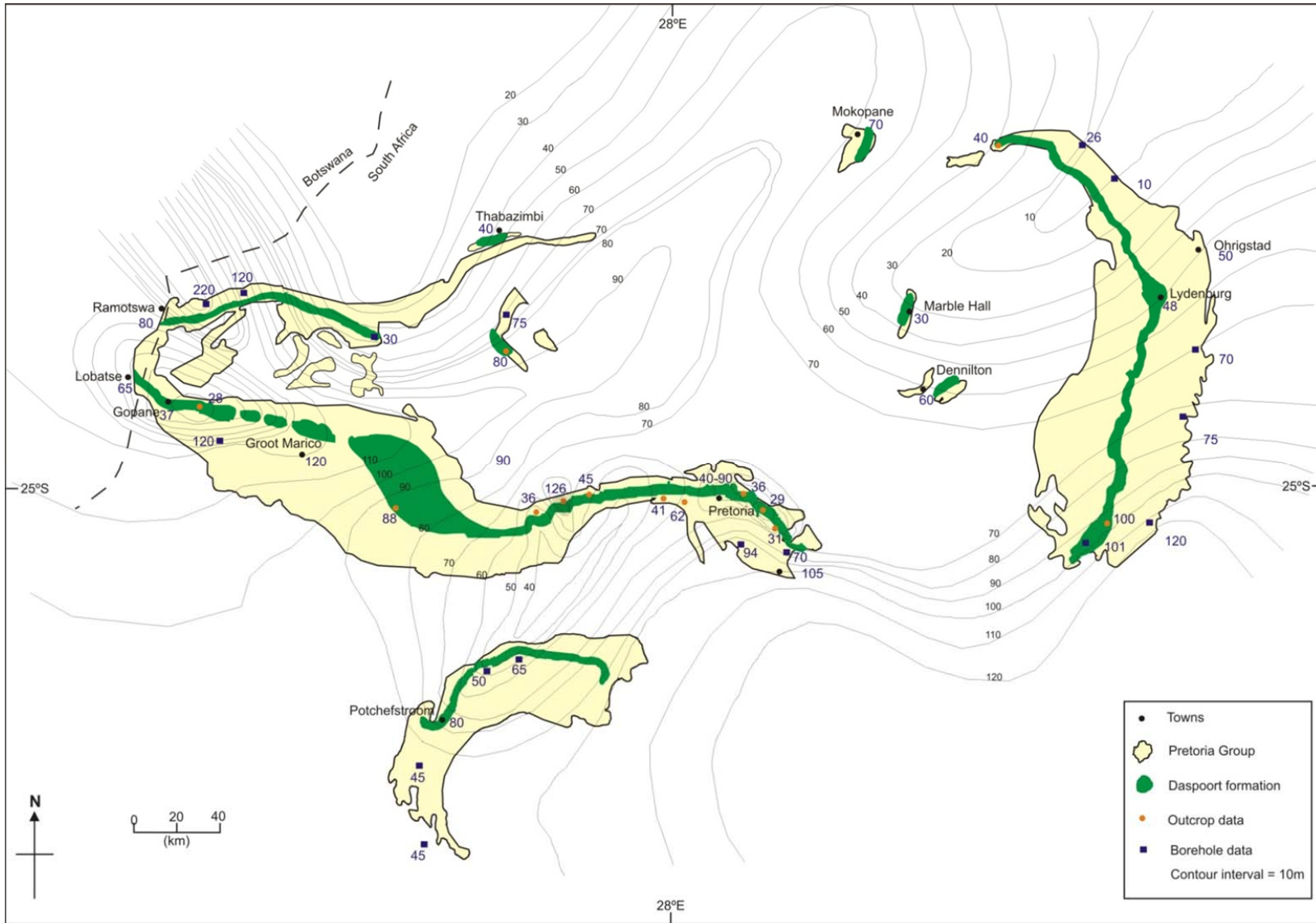

Figure 4.13 (Figure 2.2 in Chapter 2): New data and literature data provide isopach thickness plot of the Daspoort Formation. Note the basin's gradual eastern thickness changes compared to the much steeper alterations in the western part. The author's contribution is reflected by outcrop data.

4.11 Ripple marks

Van der Neut (1990) observed a linear relationship between wave ripples and low boron contents in the central Pretoria basin, while predominant wind-generated ripples were associated with a higher abundance of boron content by Schreiber (1991). These type of ripple marks, respectively, are characteristic of transgressive- and regressive system tracts and are associated with fluctuations of the palaeosalinity in closed basins, whereas the geochemistry of open marine environments are less susceptible to changes in water levels (Picard and High, 1972; in Schreiber, 1991). Van der Neut's (1990) collective measurements favour a wave-generated ripple marks using Tanner's (1971) methods (Figure 7.21).

The absence of swash-induced ripple marks, synonymous with shallow marine/beach environments, could provide more support to a non-marine depositional setting (Schreiber, 1991); alternatively, an epeiric marine basin would tend to have insignificant wave action at a shoreline far inland. Ripple marks in the eastern Pretoria basin tend to have a high ratio of ripple length to ripple height and are often weathered, thus not expected to be preserved in these ancient environments (Schreiber, 1991). Ripple marks are found in the upper units of the Daspoort Formation across the basin; ripples are poorly preserved in lower units where higher energy conditions prevailed in the basin's early stages. Poorly preserved examples do exist in the lower units, but it is where the basin started to fill up with sediment influx from the west through fluvial processes that smaller current ripples are preserved in the shallow upper units. Westward the basin-fill tends to get thicker with a flat to gentle slope inferred for the far eastern basin. Mudrocks interlaminated with rippled sandstones subsequently weathered from present day surfaces to expose the ripples as seen at Kaalbooi. These are much higher in the Daspoort succession.

It seems, as a rule of thumb, that there is a direct linear relationship between grain size and wavelength. It is also referring to the fact that larger waves result in bigger spacing between ripple marks. With deeper water conditions (onshore to shallow marine settings) the ripples will also have bigger spacing. Tricker (1965) estimated a minimum water depth of 4.3 cm for ripple mark propagation. Unfortunately the varying grain sizes do implicate expected results (Tanner, 1971). Most of the ripple marks measured were part of medium to fine grained sandstone facies, therefore being a stable parameter.

Large ripples are characteristic of tide dominated shelf environments (Walker, 1984). At Suikerboschfontein these ripples infer a transgressive systems tract as the basin started to fill in the east. The shallow marine environment envisaged for this area could accommodate tidal currents which might have built these ripples (Nio, 1976). Massive sandstones are the major lithofacies here. According to Walker (1984) these ripples associated with the described local lithofacies infer a tide dominated shelf environment. Figure 4.14 attempts to create a visual interpretation of sediment flow directions from the edge of the Pretoria Group basin together with gradient interpretations acquired from outcrop information.

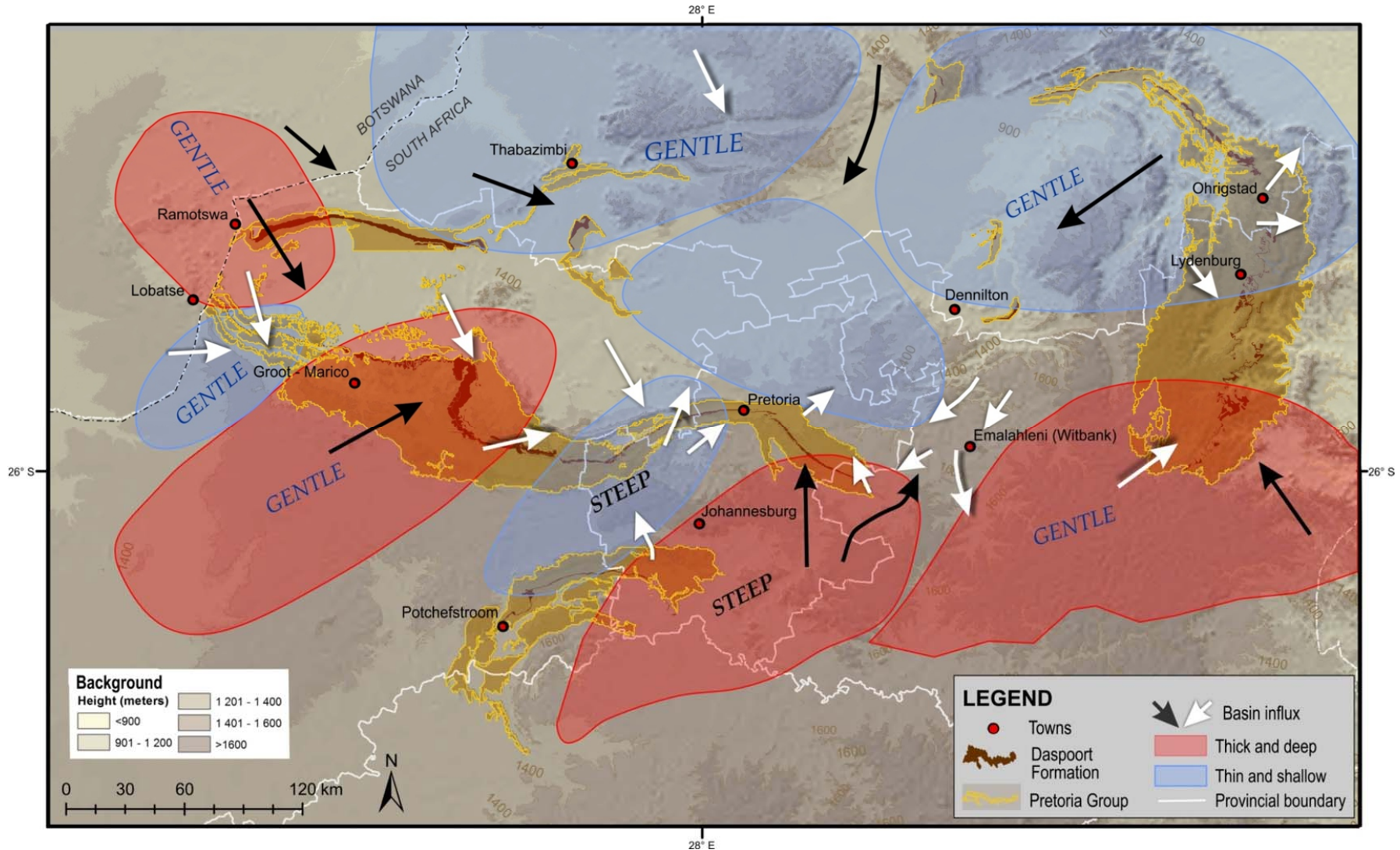

Figure 4.14: Daspoort Formation basin palaeo-topography measured from field outcrops. Major flow directions are predominantly from the WNW and ESE. Black arrows indicate major regional flow patterns whereas white arrows indicate localised flow directions. Modern day topography, architectural elements seen in outcrops, wave ripple data interpretation along with dip and strike measurements were instrumental for the construction of this figure. Arrows from the northern part of the basin was interpreted from Eriksson (et al., 1993) palaeo environment visualisation.

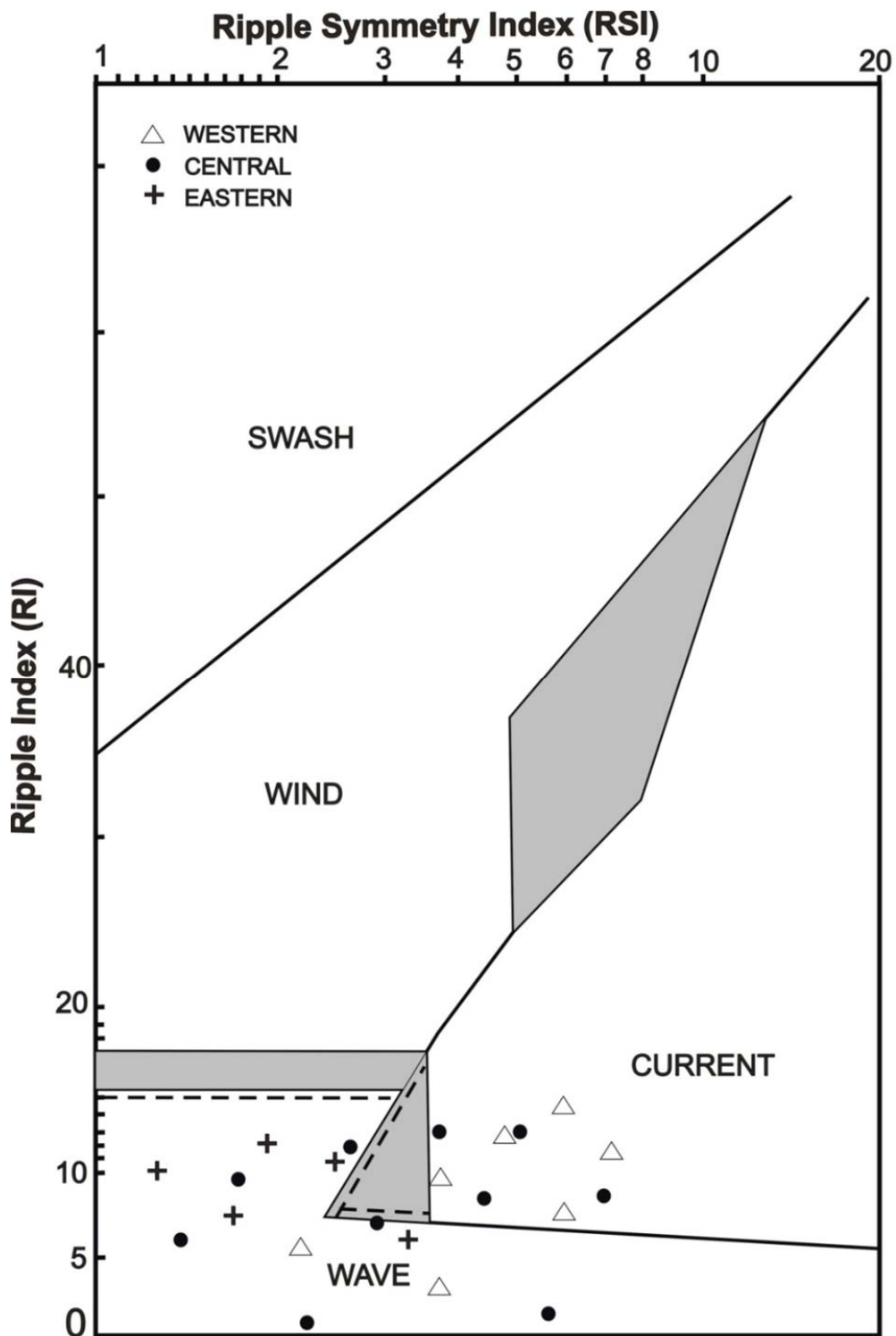

Figure 4.15: Ripple mark distribution across the Daspoort basin.

Ripple marks identified in outcrops across the Daspoort Formation yielded water depths from 19 cm to 70 cm and a maximum wave height of 10 cm using Tanner's (1969) *fetch* equations, 17, 18, 18b and 19. These equations are however unreliable as too many variable parameters resulted in unstable answers.

Asymmetrical ripples are common in field outcrops indicating possible current dominated settings whereas symmetrical ripples (often reworked asymmetrical ripples) are indicative of wave action. See **Error! Reference source not found.** for a summary of ripple mark data.

Table 8: A display of average values for calculations from ripple mark data. Due to the variability of *fetch* values, using equations 17, 18, 18b and 19 from the previous chapter, it was not taken in consideration when discussing provenance and depositional setting. The dominant ripple type is marked in bold in the bottom row.

Daspoort Ripple Mark Calculations Summary				
	West	Central	East	Basin
Water Depth (cm)	20	24	69	37
Wave Height (cm)	1.2	2	7	3.4
Fetch (km)	0.1	0.4	2.9	1.1
Ripple type	Asymmetrical/ symmetrical	Asymmetrical/ symmetrical	Symmetrical	Asymmetrical/ symmetrical
Palaeoenvironment	Fluvial	Fluvial	Shallow Marine	Fluvial

The specific procedures of the Tanner (1971, p. 84) method of formulating Figure 4.15 and ripple mark genesis are best described by this author through a direct quote from the original work in the following way:

“The vertical axis is marked in terms of the expression $0.97 s - 3.72 \ln g$,

Where s = ripple mark spacing (cm) and g (um).

These are the only measured variables available in the typical palaeogeographic problem. The horizontal axis = water depth (in cm). The solid lines sloping gently upward toward the right = water wave heights (in cm). Normally one would expect all results from such a chart to be ambiguous: once the entry point has been located on the vertical axis, there seems to be no more information and hence the results are indeterminate. This is, however, not quite correct.

The curved line, rising to the upper right = the breaker zone; waves are not propagated under conditions represented by the upper left part of the chart (to the left of the curved line).

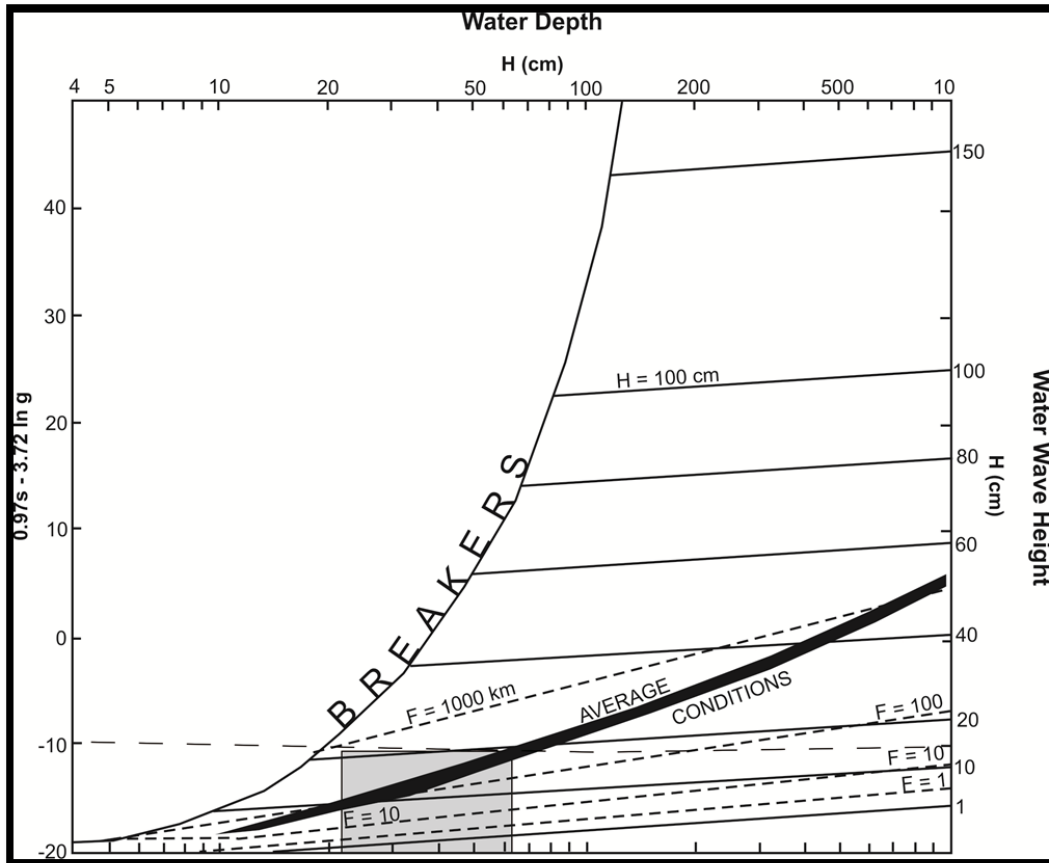

Figure 4.16: Palaeogeographic plot based on grain size and ripple mark spacing. The grey shading indicates the suggested area applicable to Daspoort palaeography using Tanner’s equations and methods described above. Modified after Tanner (1971).

*Moreover, waves are typically too small to form ripple marks in the shaded part of the chart (lower right, below thick solid black line; water wave heights less than 1 cm). The meaningful portion of the chart is the horn-shaped segment which opens toward the upper right; many ripple mark fields in the rock sequence plot in the narrow part of the horn, where uncertainty is modest (open ocean ripple marks plot in the upper, wide, portion of the horn.) **The thick solid line indicates ‘average’ conditions; where stable ripple mark spacing and grain size data can be obtained in the course of field work, the average conditions are indicated, and a reliable estimate of water depth and water wave-height can be obtained.** The dashed lines, sloping gently upward to the right, are marked in terms of fetch values (km). Once values have been determined - or estimated – for wave height and water depth, a general estimate of fetch van be read. This chart has been plotted from eq. 14 and 18 (see Tanner (1971)); the breaker line was obtained from Tricker (1965).”*

4.12 Optical petrology

The thin sections studied were helpful to determine the type, sorting and maturity of the Daspoort Formation sandstones and to a lesser extent, quartzites. Genesis and tectonic environment are difficult to derive from sometimes weathered minerals and the clastic nature of the sediments. It is notable to mention the abrasiveness of some minerals, especially quartz, and the susceptibility to physical and chemical influences during weathering, transport and deposition of the sediments in which these minerals occur. Sandstone composition in the Daspoort Formation seems to be attributed to physical transport rather than chemical alteration, bar the metamorphosed quartzites of the lower unit. Quartz dominated arenites form the bulk of the Daspoort Formation, but subordinate lithic arenites and other lithic compositions indicate that the clastic material was transported from proximal environments via channels and river systems.

The presence of continuous optical zoning in the microbial mat specimen's tourmalines indicates growth in separate events, therefore (from Van den Bleekens et al. 2006 conclusions) possibly supporting the episodic release of boron into a diagenetic cycle. Diagenetic tourmaline preserves a range of qualities during metamorphic conditions, thus making it a good indicator of diagenetic to low-grade metamorphism (Van den Bleeken et al., 2006). It is suggested that low-grade regional metamorphism could have prevailed in the far west, but nothing to speak of elsewhere in the basin, except in the Pretoria and other areas where the Silverton Formation could have altered the thinner Daspoort quartzite units, causing recrystallisation by localised intrusive action related to Silverton volcanism. The exact location and source material won't be discussed as insufficient polished thin sections and a lack of knowledge about the Palaeoproterozoic sediment genesis limits the understanding of such a discussion. Optical petrology does however serve as supporting evidence to describe sorting; sandstone maturity and general classification (Table 9).

Table 9: A general petrological summary of the sandstones of the Daspoort Formation, if divided into 3 areas.

Sandstone Classification Using Optical Petrology			
Location	West	Central	East
Sorting	Poor	Moderate	Good
Grain size	Coarse	Medium-coarse	Fine-medium
Matrix	Clastic, Clay Cement	Clastic, Interstitial Minerals	Interstitial Minerals
Classification	Wackes, Lithic Arenites	Quartz Arenite, Arkosic	Quartz Wacke, Arkosic

4.13 Comparison of models: Previous work

For comparative purposes the author's comments are printed in italic font.

Visser (1969) suggested a modified fluvial-beach depositional environment. Immature basal sandstones, upper mature arenites and northerly sourced palaeocurrents are the fundamentals of this hypothesis.

The mature arenites and often quartzitic nature of the lower Daspoort unit don't correspond with Visser's (1969) observations of the basal lithofacies assemblages. New field observations indicate that palaeocurrents are not only dominated by a northerly source, as stated by Visser (1969), but influence from the west and south-eastern part of the basin is dominant in the Daspoort Formation.

Button (1973), working in Mpumalanga Province (formerly known as Eastern Transvaal), describes the Daspoort sandstones as a beach face progradation over the offshore muds of the Strubenkop Formation. Furthermore he explained that the proposed shallow marine – beach sands of the overlying Daspoort Formation form the top of an upward-coarsening megacycle; these sands migrated southwards to the open sea, he proposed.

Like Button (1973), the Daspoort Formation can be interpreted to be the upper part of an upward-coarsening megacycle, especially in the eastern parts of the basin where these trends are seen throughout the Daspoort succession, but this postulated hypothesis is geographically limited in the eastern parts of the Daspoort Formation. Palaeocurrent directions presented in this thesis and previous palaeodata from Eriksson et al. (1993) do not concur with Button's northward progradation towards offshore muds. The presence of these muds does not concur with the migrating sands in the north towards the marine environment further south.

Elliot (1986) noted that predominant planar stratification in the absence of swash ripples should not be associated with marine sands, but rather with delta-front sands. Taking the composition and textural maturity of the Daspoort sandstones in consideration, they are applicable to delta front deposits, while ripple cross-laminated siltstone beds are interlayered with pro-delta mudstones (Coleman and Prior, 1982).

Planar stratified lithological units are not dominant in the Daspoort Formation, except near the Strubenkop Formation contact (See Paul Kruger Rd. profile and photo north of Koster). Unfortunately the upward coarsening nature for most of the Daspoort Formation contradicts delta front deposits as envisaged by Elliot (1986). The Bouma sequence (see Appendices) also does not correspond to field outcrops. Ripple cross-laminations found in the Daspoort Formation

are associated with coarse, poorly sorted sandstones (i.e. wackes etc.) and not siltstones; mudstones are found on weathering surfaces or mostly interlaminated with medium grained sandstones.

The compositional and textural maturity of the Daspoort Formation together with mega ripples in the southeast of the basin, ripple cross-bedding, hummocky cross-beds, the sheet-like nature of the Daspoort arenites, predominantly upward-coarsening cycles in the formation and interbedded argillaceous rocks, which decrease in a southerly direction and possibly represent periods of rapid transgression, could all support a beach depositional environment for the Daspoort Formation (cf., Schreiber, 1991).

Unfortunately the absence of any swash-induced ripple marks contradicts a beach palaeoenvironment for the Daspoort sandstones. Not only does this argue against a beach setting, but the thickness variation from the northeast towards the southeast indicates a wedge-like geometry, rather than a sheet-like nature. These geometrical considerations are also prominent in the Pretoria region (thin) where it thickens towards the west by more than 400% and even up to 800% near Koster. This could possibly be due to tectonic effects of the intracratonic Transvaal basin or just due to the extant geomorphology of the area.

A deltaic palaeoenvironment, with distributary mouth-bar deposits or a system of distal fan delta complexes for the Daspoort Formation is suggested by Schreiber (1991). Furthermore the presence of, what is believed to be, non-glacial varves in the underlying Strubenkop Formation suggests that a lacustrine delta or fan-delta palaeoenvironment is applicable for the Daspoort Formation in the east of the Pretoria basin (Schreiber, 1991). The genesis of these postulated deltas lay in the southeast and far northwest of this basin (Schreiber, 1991).

All the palaeo transport directions can be interpreted as distal fan or deltas debouching into a lacustrine environment, but the isolated occurrences of herringbone cross-bedding and wave induced ripple marks can point to marine conditions. Unfortunately new palaeo directions indicate transport directions similar to that of Eriksson (et al., 1993) – see Figure 4. The varved texture observed by Schreiber (1991) is probably similar to the described thinly bedded sandstone alternating with mudrocks from the Strubenkop Formation.

The intracratonic Pretoria Group basin model is dominated by tectonic influences which can be deduced from Schreiber's (1991) studies of the various Formations in the east of the basin which include alluvial fan and fan-delta complexes (Rooihoogte, Boshhoek and Dwaalheuwel Formations), volcanic activity (Hekpoort and Silverton Formations) as well as syn-depositional deformation structures in the Timeball Hill Formation (Schreiber, 1991). The Thabazimbi-Murchison Lineament in the north and the Sugarbush-Barberton Fault in the south encompassed a rift tectonic setting according to Eriksson et al. (1991; see also Schreiber, 1991).

A period of sedimentation during earlier Pretoria Group times was followed by thermal subsidence and post-rift stratigraphic onlap during the upper Pretoria Group formations' development. Both these, the Daspoort and Magaliesberg Formations, cover a great aerial extent and have a dominant overall sheet-like nature, have an absence of significant coarse clastic sandstones which can all point to a low topography for their source areas and widespread thermal subsidence in the eastern part of the Pretoria basin (Schreiber, 1991). The Daspoort arenites may represent a fan-toe braidplain (Schreiber, 1991).

The suggested depositional environments envisaged by Schreiber (1991) are concomitant with lithofacies assemblages in the eastern part of the basin. However, the central and western extents of the study area are vastly different based on lithofacies distribution and other subsequent sedimentary architectural elements.

Table 10: A chronological representation of the various models for the Pretoria Group rocks as suggested by previous workers.

Author	Year	Proposed palaeoenvironmental setting for the Proterozoic Pretoria Group rocks
Du Toit	1954	Non-marine, intracratonic basin
Visser	1957	Non-marine, intracratonic basin
Willemse	1959	Epeiric sea
Visser	1969	Epeiric sea
	1971	
	1972	
Crockett	1972	Non-marine, intracratonic basin
Eriksson	1973	Epeiric sea
Button	1973	Beach Environment
	1986	
Button and Vos	1977	Epeiric sea
Klop	1978	Epeiric sea
Beukes	1983	Epeiric sea
Engelbrecht	1986	Epeiric sea
Eriksson	1986	Non-marine, intracratonic basin
	1988	
	1989	
Eriksson et al.	1987	Non-marine, intracratonic basin
Eriksson and Clendenin	1990	Non-marine, intracratonic basin
Van der Neut	1990	Non-marine, intracratonic basin
Schreiber	1991	Delta front, shallow marine
Eriksson	1993	Alluvial fan-braidplain
Eriksson et al.	2001	Epeiric sea and fluvial braidplains

In the light of present geochemical data the Daspoort sandstones can be construed to reflect a lacustrine rather than a shallow marine environment. This is supported by the low concentration of boron in the lithologies (boron can be used as a palaeosalinity indicator according to Picard and High, 1972). Geochemical-related evidence, such as boron content in Daspoort sandstones (see Figure 4.11 and Figure 4.12 which are based on Schreiber's (1992) data), might be ambiguous to postulate a depositional environment due to the fact that it can point to a slight marine component or a lacustrine environment. Arkosic sandstones are believed to form in a low energy beach environment or shoreline deposits if its source area is granitic and in close proximity; this is applicable because there is a relative abundance of this facies across the entire basin which supports an intracratonic palaeoenvironment setting, with more evidence in favour of a fluvial rather than a marine environment (Reineck and Singh, 1973, 1980; Feuchtbauer, 1988: in Schreiber, 1991).

The upward coarsening and fining trends seen in the Daspoort sandstones could be as a result of water level changes, where high water levels (transgressions) are associated with fining upwards and low water levels (regressions) are associated with upward coarsening units.

Eriksson et al. (1993) presented two Daspoort models; the alluvial and marine models. The former is logical when factors such as lateral and vertical facies relationships, palaeocurrent trends and the significant pebbly sandstones of the central region of the basin, are taken into consideration. The marine model is supported by the high energy mature arenites, low angle cross-bedding in deposits associated with thinly laminated horizontal beds. A shallow marine setting can be supported by the presence of herringbone cross-bedding, the sheet-like nature of the sandstone facies and the bimodal palaeocurrents. Eriksson et al. (1993) have concluded that the lateral facies relationships (as a parameter) favour the alluvial model. Petrographic studies of the Daspoort Formation in the Pretoria region presented by Eriksson et al. (1993) are indicative of a low energy environment and inferred not to have been associated with reworked fluvial marine detritus.

An alternative alluvial – lacustrine palaeoenvironment for the Pretoria Group (Crockett, 1972; Eriksson, 1986, 1988; Eriksson and Clendenin, 1990) with fluvio-deltaic lake-fill sedimentation terminating deposition in the eastern part of the basin is suggested by Schreiber (1991). Observations made by Eriksson (et al., 1993) does not concur with turbidite flows or other high energy associated mudflows. Storm wave deposits were considered, but lithological facies associations discarded any reworked deep marine sediments as found in the other transitional environments in the Pretoria Group. However, most of the Daspoort data presented here are not in accord with Schreiber's (1991) hypothesis and an overall fluvial braidplain- epeiric marine basin model is preferred overall.

4.14 Summary

The nature of **ripple marks** observed in the field across the Daspoort Formation is not compliant with a single depositional environment, but rather it rather reflects a transitional period from west to east. The western and central basin has smaller ripple marks than the eastern part of the basin. This has a direct implication on water depth; the east being the deeper part of the basin gradually getting shallower towards the western part of the basin. **Microbial mat-related structures** (MRS) are found on isolated outcrops of which they are vastly different from each other. They do indicate bionic activity in shallow water, both in the deeper eastern basin and the shallower western basin. **Lithofacies assemblages** in the Daspoort Formation indicate more fluvial related diagenesis than marine or even deltaic braidplains. This is based on various sedimentary architectural elements such as composition, maturity, grain size etc. The **geomorphology** of the Daspoort Formation reflects an ellipsoidal shape with its longest axis stretching in an E-W direction. The southern extent is the steepest with flattening observed towards the east and western peripherals. The geomorphological association is believed to be pre-depositional; thus determining sediment flow patterns into the basin. **Geochemical** methods are ambiguous to determine the depositional environment of a unit, largely consisting of sandstone and quartzite. Weathered layers did expose heavy mineral assemblages, but the presence of boron (which is seen as a marine indicator) didn't necessarily pointed to a specific environment as other parameters, such as source rocks, should also be accounted for. **Optical petrology** was mainly used to determine lithological maturity and to a slight extent the minerals present in the rock. Sediment flow directions, ripple marks and channel fills were evident on a **regional scale** which create a bigger picture of interaction between lithological units, although regional correlation was limited to outcrop availability.

CHAPTER 5: CONCLUSION

The nature of the Pretoria Group sedimentary rocks has evoked a debate on whether they formed an intracratonic lacustrine basin or an epeiric marine deposit. Boron palaeosalinity described by Eriksson (1992), amidst common varves, palaeosols and inferred microtidal conditions typical of lakes, best supports the intracratonic basin model based on geochemistry. The epeiric marine model shares too many characteristics with the abovementioned such as tidal sedimentary structures, stromatolites, hummocky cross-bedding and oolites (Eriksson et al., 1993). The inhomogeneous variety of microbial mat types and lithologies should prove that the environment, though a closed basin – supported by the in-phase boron versus stratigraphic height values to give a palaeosalinity curve (Eriksson, 1992) acquired from boreholes in the south of the basin, was subjected to bimodal conditions. A uniform marine model is thus rejected. Furthermore, the presence of fluvio-deltaic sedimentation, similar to Schreiber's (1991) model, with the presence of small alluvial-like pebbles, bimodal transport directions and fluvial dominated channels indicate influx to the basin.

The stratigraphic surfaces and development of sequence system tracts are dependent on the fluctuations of base levels and their interaction with sedimentation at the shoreline. The sentiment of interplay controlling the timing of bounding surfaces and system tracts is shared by Eriksson et al., (2005) and the extent of base level changes is controlled by the balance between climatic conditions, source area tectonics and to a lesser degree the isostasy within the Pretoria Group.

The variable characteristics of the Pretoria Group as a whole, and subsequently the Daspoort Formation, don't support a stable marine environment. A lacustrine environment could be envisaged for the Strubenkop Formation. The transition from the Strubenkop lacustrine basin to the epeiric conditions of Silverton-Magaliesberg times would leave the Daspoort sandstones to fit in between. The predominant massive sandstones in the east of the basin would reflect a marine environment where sedimentation was terminated; and microbial mats prove a shallow water environment while evidence supporting fluvial transport into the basin carries more merit than that of an epeiric sea in a closed basin. Wave heights from ripple marks and subsequent calculated water depths are related to microbial mat-related structures on weathering surfaces. These are indicative of shallow water in an envisaged fluvial lacustrine-tidal epeiric coastline (Parizot et al., 2005). Other sedimentary architectural elements in the Daspoort Formation such as channel fills, sole marks etc., support the influx of clastic sediments via fluvial braid systems. The lithofacies assemblages, in particular their texture, grain size, maturity and thicknesses, have a high affinity to interpret depositional environments. The

presence of biogenic traces in the clastic sediments of the Daspoort Formation coastlines supports an ancient epeiric basin similarly found on cratons worldwide (Parizot et al., 2005). Regional patterns, including geomorphology and sediment transport directions, relate to a basin-like depositional setting. Less prominent factors such as geomorphology and optical petrology confirm the abovementioned.

Amalgamating the evidence on a weighted average basis favours the intracratonic fluvial lacustrine setting with subordinate shallow marine interactions on a regional scale.

The envisaged depositional palaeoenvironment for the Daspoort Formation includes fluvial and interactive, tidally dominated, transgressive epeiric marine conditions. This concurs with the fluctuation of base levels and sedimentation rates within the basin.

CHAPTER 6: REFERENCES

- Alam, M., Crook, K.A.W., Taylor, G.M., 1982. Herringbone cross-stratification in modern fluvial sediments, Coonamble, N.S.W., Australia, 11th Congress on Sedimentology, Proceedings, p. 147.
- Alexandr , P., Andreoli, M.A.G., Jamison, A., Gibson, R.L., 2006. ⁴⁰Ar/³⁹Ar constraints on low-grade metamorphism and cleavage development in the Transvaal Supergroup (central Kaapvaal craton): implications for the tectonic setting of the Bushveld Igneous Complex. *South Afr. J. Geol.*, Vol. 109, pp. 393-410.
- Allen, J.R.L., 1966. A beach structure due to wind-driven foam, *Journal of Sedimentary Petrology*, Vol. 37, pp. 691–692.
- Allen, J.R.L., 1968. *Current Ripples*, North Holland, Amsterdam, 433pp.
- Allen, J.R.L., 1970. *Physical processes of Sedimentation*, George Allen and Unwin Ltd., London, 248pp.
- Allen, J.R.L., 1985. Wrinkle marks: an intertidal sedimentary structure due to aseismic soft-sediment loading, *Sedimentary Geology*, Vol. 41, pp. 75–95.
- Allen, P.A., 1981. Devonian lake margin environments and processes, SE Shetland, Scotland, *Journal of the Geological Society*, Vol. 138, pp. 1-14.
- Altermann, W., Nelson, D.R., 1998. Basin analysis, sedimentation rates and regional correlations as implied by precise U-Pb zircon ages from volcanic sediments of the Neoproterozoic Campbellrand Subgroup of the Kaapvaal Craton, *Sedimentary Geology*, Vol. 120, pp. 225-256.
- Altermann, W., 2001. The oldest fossils of Africa – a brief reappraisal of reports from the Archean, *Journal of African Earth Sciences*, Vol. 33, pp. 427-436.
- Altermann, W., Kazmierczak, J. 2003. Archean microfossils: a reappraisal of early life on Earth, *Research in Microbiology*, Vol. 154, pp. 611–617.
- Anbar, A., Duan, Y., Lyons, T., Arnold, G., Kendall, B., Creaser, R., Kaufman, A., Gordon, G. et al., 2007. A whiff of oxygen before the great oxidation event?, *Science*, Vol. 317 (5846): pp. 1903–1906.
- Anhaeusser, C.R., Johnson, M.R., Thomas, R.J., 2006. *The geology of South Africa*, The Geological Society of South Africa, Johannesburg, 691pp.

Aubrecht, R., Kristin, J., 1995. Provenance of detrital tourmaline in the Lower Jurassic of the Male Karpthy Mountains, *Mineralia Slovaca*, Vol. 27, pp. 37-44.

Awramik, S.M., Bucheim, H. P., 2009. A giant, Late Archean lake system: The Meentheena Member (Tumbiana Formation; Fortescue Group), Western Australia United States Precambrian Research, Vol. 174 Issue 3/4, pp. 215-240.

Beukes, N.J., 1983. Palaeoenvironmental setting of iron-formations in the depositional basin of the Transvaal Supergroup, South Africa, In: Trendall, A.F. and Morris, R.C. (eds.), *Iron-formation: Facts and Problems*, Elsevier, Amsterdam, Holland. pp. 131-209.

Beukes, N.J., Cairncross, B., 1991. A lithostratigraphic-sedimentological reference profile for the Late Archaean Mozaan Group, Pongola Sequence: application to sequence stratigraphy and correlation with the Witwatersrand Supergroup, *South Afr J. Geol.*, Vol. 94, pp. 44-69.

Blatt, H., Middleton, G.V. and Murray, R.C., 1980. *Origin of sedimentary rocks*, PrenticeHall Inc., New Jersey, 782pp.

Boggs, J.R., 2000. *Principles of sedimentology and stratigraphy*, 3rd ed., Toronto: Merrill Publishing Company.

Boggs, S. 1987. *Principles of Sedimentology and Stratigraphy*, Merrill Publishing, Columbus, Ohio, 761pp.

Boggs, S. 2006. *Principles of sedimentology and stratigraphy*, Pearson Prentice Hall, New Jersey, 662pp.

Böhmer, R.G., 1977. Die bepaling en verspreiding van spoorelemente in afsettingsgesteentes van die Groep Pretoria, PhD. Thesis, University of Pretoria, 337pp.

Bosch, P.J.A., 1992. Die geologie van die Wolkberg Groep tussen die Abel Erasmuspas en Graskop, Oos-Transvaal, M. Sc. dissertation, Pretoria, South Africa, p. 290.

Bouma, A.H., Brenner, R.L., Knebel, H.J., 1982. Continental shelf and epicontinental seaways, *in* Scholle, P.A. and Spearing, D., eds., *Sandstone Depositional Environments: American Association of Petroleum Geologists, Memoir 31*, pp. 281–327.

Bouougri, E., Porada, H., 2007. Siliciclastic biolaminites indicative of widespread microbial mats in the Neoproterozoic Nama Group of Namibia, *Journal of African Earth Sciences*, Vol. 48, pp. 38-48.

Boyd, R., Diessel, C.F.K., Wadsworth, J., Chalmers, G., Little, M., Leckie, D., Zaitlin, B., 1999. Development of a nonmarine sequence stratigraphic model, American Association of Petroleum Geologists Annual Meeting, San Antonio, Texas, USA. Official Program, p. A15.

Bumby, A.J., Eriksson, P.G., Van der Merwe, R., 1998. Compressive deformation in the floor rocks to the Bushveld Complex (South Africa): evidence from the Rustenburg Fault Zone, *Journal of African Earth Sciences*, Vol. 27, pp. 307-330.

Button, A., 1973. A regional study of the stratigraphy and development of the Transvaal Basin in the eastern and northeastern Transvaal, Ph.D. thesis (unpubl.), University of the Witwatersrand, Johannesburg, South Africa, 352pp.

Catuneanu, O., Eriksson, P.G., 1999. The sequence stratigraphic concept and the Precambrian rock record: an example from the 2.7-2.1 Ga Transvaal Supergroup Kaapvaal craton. *Precambrian Research*, Vol. 97, pp. 215–251.

Catuneanu, O. 2006. *Principles of Sequence Stratigraphy*, Elsevier, Amsterdam, 375pp.

Catuneanu, O. 2002. *Journal of African Earth Sciences*, Vol. 35/1, pp. 1-43.

Catuneanu, O., Abreu, V., Bhattacharya, J.P., Blum, M.D., Dalrymple, R.W., Eriksson, P.G., Fielding, C.R., Fisher, W.L., Galloway, W.E., Gibling, M.R., Giles, K.A., Holbrook, J.M., Jordan, R., Kendall, C.G.St.C., Macurda, B., Martinsen, O.J., Miall, A.D., Neal, J.E., Nummedal, D., Pomar, L., Posamentier, H.W., Pratt, B.R., Sarg, J.F., Shanley, K.W., Steel, R.J., Strasser, A., Tucker, M.E., Winker, C., 2009. Towards the standardization of sequence stratigraphy, *Earth-Science Reviews*, Vol. 92, pp. 1–33.

Catuneanu, O., Martins-Neto, M.A., Eriksson, P.G., 2012. Sequence stratigraphic framework and application to the Precambrian, *Marine and Petroleum Geology*, Vol. 33, pp. 26-33.

Chamley, H., 1989. *Clay Sedimentology*, Springer-Verlag, Berlin, 623pp.

Chaussidon, M., Uitterdijk Appel, P.W., 1997. Boron isotopic composition of tourmalines from the 3Ga-old Isua supracrustals, West Greenland: implications on the $\delta^{11}\text{B}$ value of early Archean seawater, *Chemical Geology*, Vol. 136, pp. 171-180.

Clifton, H. E., Hunter, R. E. and Phillips, R. L., 1971. Depositional structures and processes in the non-barred high-energy nearshore, *Journal of Sedimentary Petrology*, Vol. 41, pp. 651-670.

Collinson, J. D. and Thompson, D. B., 1982. *Sedimentary Structures*, George Allen and Unwin Ltd., London, U.K.

Collinson, J.D. and Thompson, D.B., 1989. *Sedimentary Structures*, George Allen and Unwin Ltd., London, 194pp.

Condie, K.C., 1989. *Plate tectonics and crustal evolution*, Pergamon, Oxford, U.K, 476pp.

Condie, K.C. and Wronkiewicz, D.J., 1990. The Cr/Th ratio in Precambrian pelites from the Kaapvaal Craton as an index of Craton evolution, *Earth Planet. Science Letters*, Vol.97, pp. 256–267.

De Raaf, J.F.M., Boersma, J.R., van Gelder, A., 1977. Wave-generated structures and sequences from a shallow marine succession, Lower Carboniferous, *Sedimentology*, Vol. 24, pp. 451–483.

Dickinson, W.R., Beard, L.S., Brakenridge, G.R., Erjavec, J.L., Ferguson, R.C., Inman, K.F., Knepp, R.A., Lindberg, F.A. and Ryberg, P.T., 1983. Provenance of North American Phanerozoic sandstones in relation to tectonic setting, *Geological Society American Bulletin*, Vol. 94, pp. 222-235.

Dole, M. (1965). The Natural History of Oxygen, *The Journal of General Physiology* Vol.49 (1): pp. 5-27.

Donoghue, P.C.J., Antcliffe, J.B., 2010. Origins of multicellularity, *Nature*, Macmillan Publishers, Vol. 466, p. 41.

Dott, R. H. (1964). Wacke, Graywacke and matrix-what approach to immature sandstone classification, *Journal of Sedimentary Petrology*, Vol. 34, pp. 625-632.

Dott, R. H., Bourgeois, J., 1982. Hummocky Stratification: Significance of Its Variable Bedding Sequences, *Geological Society of America Bulletin* 93.8, pp. 663-680.

Dutkiewicz, A., Volk, H., George, S. C., Ridley, J., Buick, R., 2006. Biomarkers from Huronian oil-bearing fluid inclusions: an uncontaminated record of life before the Great Oxidation Event, *Geology*, Vol.34 (6), 437pp.

El Albani A., Bengtson S., Canfield D.E., Bekker A., Macchiarelli R., Mazurier A., Hammarlund E., Boulvais P., Dupuy J.-J., Fontaine C., Fürsich F.T., Gauthier-Lafaye F., Janvier P., Javaux E., Ossa Ossa F., Pierson-Wickmann A.-C., Riboulleau A., Sardini P., Vachard D., Whitehouse M.&Meunier A., 2010. Large colonial organisms with coordinated growth in oxygenated environments 2.1 Gyr', *Nature*, Vol. 466, Issue 7302, pp. 100-104.

Elliot, T., 1978a. Deltas, pp. 97-142, In: Reading, H.G., Ed., *Sedimentary facies and environments*, Blackwell Scientific Publs., Oxford, 557pp.

Elliot, T., 1978b. Clastic shorelines, pp. 143 – 177, In: Reading, H.G., Ed., *Sedimentary facies and environments*, Blackwell Scientific Publs., Oxford, 557pp.

Engelbrecht, J.P., 1986. Die Bosveldkompleks en sy vloergesteentes in die omgewing van Nietverdiend, Wes-Transvaal, PhD thesis, University of Pretoria, 327pp.

Eriksson, P.G., 1986. Sedimentological aspects of the Pretoria Group in the Pretoria-Rustenburg area. Abstr. Geocongress '86, Johannesburg, South Africa, pp. 509-511.

Eriksson, P.G., 1988. A palaeoenvironmental review of the Pretoria Group, Transvaal Sequence, Abstr. Geocongress '88, Durban, South Africa, pp. 187-190.

Eriksson, P.G., 1988. Sedimentology of the Rooihogte Formation, Transvaal Sequence, South African Journal of Geology, Vol. 91, pp. 477-489.

Eriksson, P.G., Meyer, R., Botha, W.J., 1988. A hypothesis on the nature of the Pretoria Group basin. S. Afr. J. Geol., Vol. 91, pp. 490-497.

Eriksson, P.G. and Clendenin, C.W., 1990. A review of the Transvaal Sequence, South Africa, J. Afr. Earth Sci., Vol.10, pp. 101-116.

Eriksson, P.G., Schreiber, U.M., and Van der Neut, M., 1991. A review of the sedimentology of the Early Proterozoic Pretoria Group, Transvaal Sequence, South Africa: implications for tectonic setting, Journal of African Earth Sciences, Vol.13, pp. 107-119.

Eriksson, P.G., Cheney, E. S., 1992. Evidence for the transition to an oxygen-rich atmosphere during the evolution of red beds in the Lower Proterozoic sequences of southern Africa, Precambrian Research, Vol.54, pp. 257-269.

Eriksson, P.G., Schreiber, U.M., van der Neut, M., Labuschagne, H., van der Schyff, W., Potgieter, G., 1993. Alternative marine and fluvial models for the non-fossiliferous quartzitic sandstones of the Early Proterozoic Daspoort Formation Transvaal Sequence of Southern Africa. J. Afr. Earth Sci. 16, pp. 355–366.

Eriksson, P.G., Reczko, B.F.F., Boshoff, A.J., Schreiber, U.M., Van der Neut, M., Snyman, C.P., 1995. Architectural elements from Lower Proterozoic braid-delta and high-energy tidal flat deposits in the Magaliesberg Formation, Transvaal Supergroup South Africa. Sedimentary Geology, Vol. 97, pp. 99–117.

Eriksson, P.G., Hatting, P.J., Altermann, W., 1995. An overview of the geology of the Transvaal Sequence and Bushveld Complex, South Africa. Mineralium Deposita, Vol.30., No.2, pp. 98-111.

Eriksson, P.G., Condie K.C., Tirsgaard, H., Mueller, W.U., Altermann, W., Miall, A.D., Aspler, L.B., Catuneanu, O., Chiarenzelli, J.R., 1998. Precambrian clastic sedimentation systems. Sedimentary Geology, Vol. 120, pp. 5–53.

Eriksson, P.G., Altermann, W., Catuneanu, O., Van der Merwe, R., Bumby, A.J., 2001. Major influences on the evolution of the 2.67-2.1 Ga Transvaal basin, Kaapvaal craton, Sedimentary Geology, Vol. 141-142, pp. 205-231.

- Eriksson, P.G., Altermann, W., Eberhardt, L., Ahrend-Heidbrinck, S., Bumby, A.J., 2002. Palaeoproterozoic epeiric sea palaeoenvironments: The Silverton Formation (Pretoria Group Transvaal Supergroup), South Africa. In: Altermann, W., Corcoran, P.L. (Eds.), *Precambrian Sedimentary Environments: a modern approach to ancient depositional systems*. Blackwell, Oxford, pp. 351–368.
- Eriksson, P.G., Catuneanu, O., Nelson, D.R., Mueller, W.U., Altermann, W., 2004. *The Precambrian Earth: tempos and events*, Elsevier, Amsterdam, 941pp.
- Eriksson, P.G., Catuneanu, O., Sarkar, S. and Tirsgaard, H., 2005. Patterns of sedimentation in the Precambrian, *Sedimentary Geology*, Vol. 176, pp. 17-42.
- Eriksson, P.G., Altermann, W., Hartzler, F.J., The Transvaal Supergroup and its precursors, In: Johnson, M.R., Anhaeusser, C.R., Thomas, R.J., 2006. *The Geology of South Africa*, pp. 237-260.
- Eriksson, P.G., Bumby, A.J., Brümer, J.J., Van der Neut, M., 2006. Precambrian fluvial deposits: enigmatic palaeohydrological data from the c. 2-1.9 Ga Waterberg Group, South Africa, *Sedimentary Geology*, Vol. 190, pp. 25-46.
- Eriksson, P.G., Banerjee, S., Catuneanu, O., Sarkar, S., Bumby, A.J., Mtimkulu, M.N., 2007. Prime controls on Archaean–Palaeoproterozoic sedimentation: Change over time, *Gondwana Research*, Vol. 12, pp. 550–559.
- Eriksson, P.G., Bose, P.K., Catuneanu, O., Sarkar, S., Banerjee, S., 2008. Precambrian clastic epeiric embayments: Examples from South Africa and India, *Geological Association of Canada, From Special Paper Vol. 48: Dynamics of Epeiric Seas*, pp. 119–136.
- Eriksson, P.G., Long, D., Bumby, A.J., Eriksson, K., Simpson, E., Catuneanu, O., Claassen, M., Mtimkulu, M., Mudziri, K., Brümer, J., Van der Neut, M., 2008. Palaeohydrological data from the c. 2.0 to 1.8 Ga Waterberg Group, South Africa: discussion of a possibly unique Palaeoproterozoic fluvial style, *South African Journal of Geology*, Vol. 111, pp. 281-304.
- Eriksson, P.G., Rautenbach, C.J. de W., Wright, D.T., Bumby, A.J., Cauneanu, O., Mostert, P., Vand der Neut, M., 2009. Possible evidence for episodic epeiric marine and fluvial sedimentation (and implications for palaeoclimatic conditions), c. 2.3-1.8 Ga, Kaapvaal craton, South Africa. *Palaeogeography, Palaeoclimatology, Palaeoecology*, Vol. 273, pp. 153–173.
- Eriksson, P.G., Sarkar, S., Banerjee, S., Porada, H., Catuneanu, O., Samanta, P. 2010. Palaeoenvironmental context of microbial mat-related structures in siliciclastic rocks – Examples from the Proterozoic of India and South Africa in *Microbial Mats: Cellular Origin, Life in Extreme Habitats and Astrobiology*, Vol. 14, Part 2, pp. 71-108.
- Eriksson, P.G., Bartman, R.D., Catuneanu, O., Mazumder, R., Lenhardt, N., 2012. A case study of microbial mat-related features in coastal epeiric sandstones from the Palaeoproterozoic

Pretoria Group (Transvaal Supergroup, Kaapvaal craton, South Africa); The effect of preservation (reflecting sequence stratigraphic models) on the relationship between mat features and inferred palaeoenvironment, *Sedimentary Geology*, Vol. 263–264, pp. 67–75.

Forterre, P., Benachenhou-Lahfa, N., Confalonieri, F., Duguet, M., Elie, C. and Labedan, B., 1992. The nature of the last universal ancestor and the root of the tree of life, still open questions, *BioSystems*, Vol. 28 (1-3), pp. 15–32.

Frei, R., Gaucher, C., Poulton, S. W., Canfield, D. E., 2009. Fluctuations in Precambrian atmospheric oxygenation recorded by chromium isotopes, *Nature*, Vol.461 (7261), pp. 250–253.

Friedman, G.M., 1967. Dynamic processes and statistical parameters for size frequency distribution of beach and river sands, *Journal of Sedimentary Petrology*, Vol. 37, pp. 327-354.

Goldblatt, C., T.M. Lenton, A.J. Watson, 2006. The Great Oxidation at 2.4 Ga as a bistability in atmospheric oxygen due to UV shielding by ozone, *Geophysical Research Abstracts*, Vol. 8, 770pp.

Hampton, M.A., Torresan, M.E., Barber, Jr., J.H., 1997. Sea-floor geology of a part of Mamala Bay, Hawaii: *Pacific Science*, Vol. 51, n. 1, pp. 54-75.

Hartzer, F.J., 1995. Transvaal Supergroup inliers: geology and relationship with the Bushveld Complex, PhD dissertation, Rand Afrikaans University, Johannesburg, 415pp.

Hazen, R.M., 2010. Evolution of Minerals, *Scientific American*, Vol. 302 Issue 3, pp. 58-65.

Henry, D.J., Dutrow, B., 1992. Tourmaline in a low grade clastic metasedimentary rock: an example of the petrogenetic potential of tourmaline, *Contrib. Mineral Petrol*, Vol. 112, pp. 203-218.

Henry, D.J., Lu, G., McCabe, C., 1994. Epigenetic tourmaline in sedimentary red-beds: An example from the Silurian Rose Hill Formation, Virginia, *The Canadian Mineralogist*, Vol. 32, pp. 599-605.

Hoenigsberg, H., 2003. Evolution without speciation but with selection: LUCA, the Last Universal Common Ancestor in Gilbert's RNA world, *Genetic and Molecular Research*, Vol. 2 (4), pp. 366–375.

Holland, H.D., 2006. The oxygenation of the atmosphere and oceans, Harvard University, Cambridge, USA, *Phil. Trans. R. Soc. B*, Vol. 361, pp. 903-915.

Holland, H.D., 2009. Why the atmosphere became oxygenated: A proposal, *Geochimica et Cosmochimica Acta* 73, pp. 5241-5255.

- Hubert, J.F., 1962. A Zircon-Tourmaline-Rutile maturity index and the interdependence of the composition of heavy mineral assemblages with the gross composition and texture of sandstones, *Journal of Sedimentary Petrology*, Vol.32, pp. 440-450.
- Hunt, D., Tucker, M.E., 1992. Stranded Parasequences and the forced regressive wedge Systems Tract: deposition during base-level fall, *Sedimentary Geology*, Vol. 81, pp. 1–9.
- Johnson, M.R., 1991. Sandstone petrography, provenance and plate tectonic setting in Gondwana context of the southeastern Cape-Karoo Basin, *South African Journal of Geology*, Vol. 94, pp. 137-154.
- Key, R.M., 1983. The geology of the area around Gaborone and Lobatse, Kweneng, Kgatleng, Southern and South Eastern Districts. District Memoir Geological Survey, Botswana 5, 230pp.
- Knoll, Andrew H.; Javaux, E.J, Hewitt, D. and Cohen, P., 2006. Eukaryotic organisms in Proterozoic oceans, *Philosophical Transactions of the Royal Society of London, Part B*, Vol. 361 (1470), pp. 1023–1038.
- Konhauser, K.O., Lalonde, S.V., Planavsky, N.J., Pecoits, E., Lyons, T.W., Mojzsis, S.J., Rouxel, O.J., Barley, M.E., Rosière, C., Fralick, P.W., Kump, L.R., Bekker, A., 2011. Oceanic nickel depletion and a methanogen famine before the Great Oxidation Event, *Nature*, Vol. 478, Issue 7369, pp. 369-373.
- Kopp, R.E., Kirschvink, J.L., Hilburn, I.A., Nash, C.Z., 2005. The Paleoproterozoic snowball Earth: A climate disaster triggered by the evolution of oxygenic photosynthesis, *Proc. Natl. Acad. Sci. U.S.A.* Vol. 102 (32), pp. 11131–11136.
- Krynine, P.D., 1946. The tourmaline group in sediments, *The Journal of Geology*, Vol.54, pp. 65-87.
- Kummel, B., Teichert, C., 1970. Stratigraphy and paleontology of the Permian–Triassic boundary beds, Salt Range and Trans-Indus Ranges, West Pakistan, In: Kummel, B., Teichert, C. (Eds.), *Stratigraphic boundary problems, Permian and Triassic of Pakistan*, Geological Department, University of Kansas, Special Publication 4, 110pp.
- Lambert, D., 2007. *The field guide to Geology*, New Edition, Checkmark Books, 304pp.
- Lancaster, N., 1981. Grain size characteristics of Namib Desert linear dunes, *Sedimentology*, Vol. 28, pp. 115-122.
- Lane, N., 2010. A snowball period, c2.4 - c2.0 Ga, triggered by the Oxygen catastrophe, *First breath: Earth's billion-year struggle for oxygen*, *New Scientist*, Vol.2746, p. 1.

Lenton, T. M., Schellnhuber, H. J., Szathmáry, E., 2004. Climbing the co-evolution ladder, *Nature*, Vol. 431, Issue 7011, 913pp.

Long, 1978. Proterozoic stream deposits: some problems of recognition and interpretation of ancient sandy fluvial systems, pp. 313-341. In: Miall, A.D., ed., *Fluvial Sedimentology*, Canadian Society of Petroleum Geologists, Calgary, Alberta, 859pp.

Mapeo, R.B.M., Armstrong, R.A., Kampunzu, A.B., 2001. SHRIMP U-Pb zircon geochronology of gneisses from the Gweta borehole, northeast Botswana: implications for the Palaeoproterozoic Magondi Belt in southern Africa, *Geology Magazine*, Vol. 138, pp. 299-308.

Mapeo, R.B.M., Ramokate, L.V., Armstrong, R.A., Kampunzu, A.B., Modisi, M.P., Modie, M.P., 2006. A ca. 200 Ma hiatus between the Lower and Upper Transvaal Groups of southern Africa: SHRIMP U-Pb detrital zircon evidence from the Segwagwa Group, Botswana: Implications for the Palaeoproterozoic glaciations, *Earth and Planetary Science Letters*, Vol. 244, pp. 113-132.

Mapeo, R.B.M., Ramokate, L.V., Armstrong, R.A., Kampunzu, A.B., 2004. U-Pb zircon age of the upper Palapye group (Botswana) and regional implications, *J. Afr. Earth Sci.* Vol. 40, pp. 1-16.

Mapeo, R.B.M., Ramokate, L.V., Armstrong, R.A., Kampunzu, A.B., 2004. SHRIMP U-Pb zircon ages of granitoids from the Western Domain of the Kaapvaal Craton, southeastern Botswana: implications for crustal evolution, *South African Journal of Geology*, Vol. 107, pp. 159-172.

Mapoe, R.B.M., Wingate, M.T.D., 2009. SHRIMP U-Pb zircon age for the Segwana-Masoke Igneous Complex of southeastern Botswana and implications for the deformation history of the Archaean to Proterozoic Transvaal Supergroup of southern Africa, *J. Afr. Earth Sci.*, Vol. 54, pp. 97-106.

Marshak, S., 2008. *A Surface Veneer: Sediments, Soils and Sedimentary Rocks*, Chapter 7, *Earth Portrait of a Planet*, 3rd Edition, New York, W.W Norton & company, 211pp.

Master, S., 1993. Geodynamic evolution and correlation of the Magondi belt (Zimbabwe): implications for the Palaeo-proterozoic history of Botswana, *Botswana J. Earth Sci.*, Vol.2, pp. 25-32.

Mata, S.A., Bottjer, D.J., 2009. The palaeoenvironmental distribution of Phanerozoic wrinkle structures, *Earth Science Reviews*, Vol. 96, pp. 181-195.

McKee, E.D., 1954. Stratigraphy and history of the Moenkopi formation of Triassic age, *Geological Society of America. Memoir* 61, 133pp.

Miall, A. D., 1977. A review of the braided-river depositional environment, *Earth-Science Review*, Vol. 13, pp. 1-62.

- Miall, A.D., 1984. Principles of sedimentary basin analysis, Springer-Verlag, Toronto, 490pp.
- Miall, A.D., 1992. Alluvial deposits. In: R.G. Walker and N.P. James (Editors), Facies models: response to sea level change, Geological Association of Canada, St. John's, Newfoundland, pp. 119-142.
- Mitchum Jr., R.M., 1977. Seismic Stratigraphy and global changes of sea level. Part 11: glossary of terms used in seismic Stratigraphy. In: Payton, C.E. (Ed.), Seismic Stratigraphy - Applications to Hydrocarbon Exploration, Vol. 26. A.A.P.G. Memoir, pp. 205–212.
- Neal, W.J., Pilkey, O.H., Kelley, J.T., 2007. Atlantic coast beaches : a guide to ripples, dunes, and other natural features of the seashore, Publisher Missoula, Mountain Press, USA.
- Nelson, D.R., Trendall, A.F., Altermann, W., 1999. Chronological correlations between the Pilbara and Kaapvaal cratons. Precambrian Research, Vol. 97, pp. 165-189.
- Nelson, S.A., 2000. Sandstone and Conglomerates, Geology 212 notes on Petrology, University of Tulane.
- Nesbitt, H.W. and Young, G. M., 1982, Early Proterozoic climates and plate motions inferred from major element chemistry of lutites, Nature, Vol. 299, pp. 715-717.
- Neuendorf, K.K.E., Mehl, J.P., Jackson, J.A., 2005. Glossary of Geology, Fifth Edition, American Geological Institute, Virginia, 779pp.
- Nielsen, T.N., 1982. Alluvial sand deposits. In: Sandstone depositional environments (edited by Scholle, P.A. and Spearing, D.), A.A.P.G., Tulsa, U.S.A., pp. 49-86.
- Nio, S.D., 1976. Marine transgressions as a factor in the formation of sandwave complexes, Geologie en Mijnbou, Vol. 55, pp. 18-40.
- Noffke, N., Knoll, A.H., Grotzinger, J.P., 2002. Sedimentary controls on the formation and preservation of microbial mats in siliciclastic deposits: a case study from the Upper Neoproterozoic Nama Group, Namibia, PALAIOS, Vol. 17, pp. 533-544.
- Parizot, M., Eriksson, P.G., Aifa, T., Sarkar, S., Banerjee, S., Catuneanu, O., Altermann, W., Bumby, A.J., Bordy, E.M., Van Rooy, L., Boshoff, J., 2005. Suspected microbial mat-related crack-like sedimentary structures in the Palaeoproterozoic Magaliesberg Formation sandstones, South Africa; Precambrian Research, Vol. 138, pp. 274-296.
- Pettijohn, F.J., 1954. Classification of Sandstones, The Journal of Geology, Vol. 62, No. 4, pp. 360-365.

Pettijohn, F.J., Potter, P.E. and Siever, R., 1972. Sand and Sandstone, New York, Springer, 553pp.

Pflüger, F., 1999. Matground structures and redox facies, *Palaios*, Vol.14, pp. 25–39.

Plint, A.G., 1988. Sharp-based shoreface sequences and “offshore bars” in the Cardium Formation of Alberta; their relationship to relative changes in sea level, In: Wilgus, C.K., Hastings, B.S., Kendall, C.G.St.C., Posamentier, H.W., Ross, C.A., Van Wagoner, J.C. (Eds.), *Sea Level Changes — An Integrated Approach*, Society of Economic Paleontologists and Mineralogists (SEPM), Special Publication, Vol. 42., pp. 357–370.

Plint, A.G., Nummedal, D., 2000. The falling stage Systems Tract: recognition and importance in Sequence stratigraphic analysis. In: Hunt, D., Gawthorpe, R.L. (Eds.), *Sedimentary Response to Forced Regression*, Vol. 172, *Geol. Soc. London Spec. Publ.*, pp. 1–17.

Porada, H., Bouougr, E., 2007. Wrinkle Structures – a critical review, 2007, *Earth Science Reviews*, Vol. 81, pp. 199-215.

Posamentier, H.W., Allen, G.P., 1999. *Siliciclastic Sequence Stratigraphy: concepts and applications*, SEPM Concepts in Sedimentology and Paleontology no. 7, 210pp.

Reading, H.G., 1986. African Rift tectonics and sedimentation: an introduction. In: L.E. Frostick, R.W. Renault, I.Reid and J.-J. Tiercelin (editors), *Sedimentation in the African Rifts*; *Geol. Soc. Spec. Publ.*, Vol. 25, pp. 3-7.

Reczko, B.F.F., 1994. The Geochemistry of the sedimentary rocks of the Pretoria Group, Transvaal Sequence, Ph.D. Thesis, University of Pretoria, South Africa, 383pp.

Rust, I.C., 1961. Note on turbidite structures in the Pretoria Series, *Trans. Geol. Soc. S. Afr.*, Vol. 64, p. 99.

Sarkar, S., Banerjee, S., Eriksson, P.G., Catuneanu, O., 2005. Microbial mat control on siliciclastic Precambrian sequence stratigraphic architecture: examples from India. *Sedimentary. Geology*, Vol. 176, pp. 195–209.

Schieber, J., 2004. Microbial mats in the siliciclastic rock record: a summary of diagnostic features. In: Eriksson, P.G., Altermann, W., Nelson, D.R., Mueller, W.U., Catuneanu, O. (Eds.), *The Precambrian Earth: tempos and events*. Elsevier, Amsterdam, pp. 663–673.

Schieber, J., Bose, P.K., Eriksson, P.G., Banerjee, S., Sarkar, S., Altermann, W., Catuneanu, O., editors, 2007. *Atlas of microbial mat features preserved within the siliciclastic rock record*. *Atlases in Geoscience 2*, Elsevier, Amsterdam, 311pp.

Schopf, T.J.M., 1980. *Palaeoceanography*, Harvard University Press, Cambridge, Massachusetts, 315pp.

Schreiber, U.M., 1991. A palaeoenvironmental study of the Pretoria Group in the eastern Transvaal. Ph. D. thesis (unpubl.), University of Pretoria, Pretoria, South Africa, 308pp.

Schreiber, U.M., Eriksson, P.G., 1992., An Early Proterozoic braid-delta system in the Pretoria Group, Transvaal Sequence, South Africa, *Journal of African Earth Sciences*, Vol. 15, pp. 111-125.

Schreiber, U.M., Eriksson, P.G., Meyer, P.C., and Van der Neur, M., 1990. The sedimentology of the Boshhoek Formation (Transvaal Sequence), *South African Journal of Geology*, Vol. 93, pp. 567-573.

Schreiber, U.M., Eriksson, P.G., Snyman, C.P., 1992. Mudrock geochemistry of the Proterozoic Pretoria Group, Transvaal Sequence (South Africa): geological implications. *Journal of African Earth Sciences*, Vol. 14, pp. 393-409.

Seibold, E., Berger, W.H., 1996. *The Sea Floor: an introduction to Marine Geology*, Springer, 356pp.

Selley, R.C., 1968. A classification of palaeocurrent models, *J. Geol.*, Vol. 76, pp. 99-110.

Shrock, R.R., 1948. *Sequence in Layered Rocks*, McGraw-Hill, New York, 507pp.

South African Committee for Stratigraphy (SACS), 1980. *Stratigraphy of South Africa, Part 1 (Comp. L.E. Kent), Lithostratigraphy of South Africa, South West Africa/Namibia and the Republics of Bophuthatswana, Transkei, and Venda*, Handbk. Geol. Surv, S. Afr., Vol. 8, 690pp.

Strahler, A., 1963. *The Earth Sciences*, New York, Harper and Row, 681pp.

Swift, D.J.P., Nedoroda, A., 1985. Fluid and sediment dynamics on Continental Shelves. In R.W. Tillman et al., Eds., *Shelf sands and sandstone reservoirs. Society of Economic Palaeontologists and Mineralogists, Short Course 13*, pp. 47-133.

Tankard, A.J., Barwis, J.H., 1982. Wave-dominated deltaic sedimentation in the Devonian Bokkeveld Basin of South Africa. *Journal of Sedimentary Petrology*, Vol. 52, pp. 959-974.

Tankard, A.J., Jackson, M.P.A., Eriksson, K.A., Hobday, D.K., Hunter, D.R., Minter, W.E.L., 1982. *Crustal Evolution of South Africa*, Springer, New York, 523pp.

Tanner, W.F., 1967. Ripple mark indices and their uses, *Sedimentology*, Vol. 9, pp. 89-104.

- Tanner, W.F., 1971. Numerical estimates of ancient waves, water depths and fetch, *Sedimentology*, Vol. 16, pp. 71–88.
- Trevors, J.T., Abel, D.L., 2004. Chance and necessity do not explain the origin of life, *Cell Biol. Int.*, Vol. 28 (11), pp. 729–39.
- Tricker, R.A.R., 1965. *Bores, Breakers, Waves and Wakes*. Elsevier, New York, 250pp.
- Tucker, M.E., 2001. *Sedimentary Petrology*, 3rd edition, WileyBlackwell, 272pp.
- Van der Merwe, R., Roering, C., Smit, C.A., 1988. Slickenside analysis of the Potchefstroom Fault, *South African Journal of Geology*, Vol. 91, pp. 264-274.
- Van den Bleeken, G., Corteel, C., Van den Haute, P., 2007. Epigenetic to low-grade tourmaline in the Gdumont metaconglomerates (Belgium): A sensitive probe of its chemical environment of formation, *Lithos*, Vol. 95, pp. 165-176.
- Van der Neut, M., 1990. Afsettingstoestande van die Pretoria Groep gesteentes in die Pretoria-Bronkhorstspuit-Delmas gebied, MSc. thesis, University of Pretoria, South Africa, 233pp.
- Visser, J.N.J., 1969. 'n Sedimentologiese studie van die Serie Pretoria in Transvaal, D.Sc. Thesis (unpubl.), Univ. Free State, Bloemfontein, 263pp.
- Wade, R.P., 2009. A systematic for interpreting past structures with possible cosmic references in sub-Saharan Africa, MSc Thesis, Pretoria. 266pp.
- Walker, R.G., 1979. *Facies Models*, Reprinted with revisions from a series of papers in *Geoscience Canada*, 1976–1979, Geological Association of Canada, 211pp.
- Walker, R.G., 1984. *Facies Models*, Second Edition, Ontario Canada, 317pp.
- Wunderlich, F., 1970. Genesis and environment of the “Nellenköpfenschichten” (Lower Emsian, Rheinian Devon) at locus typicus in comparison with modern coastal environment of the German Bay, *Journal of Sedimentary Petrology*, Vol. 40, pp. 102–130.

CHAPTER 7: APPENDICES

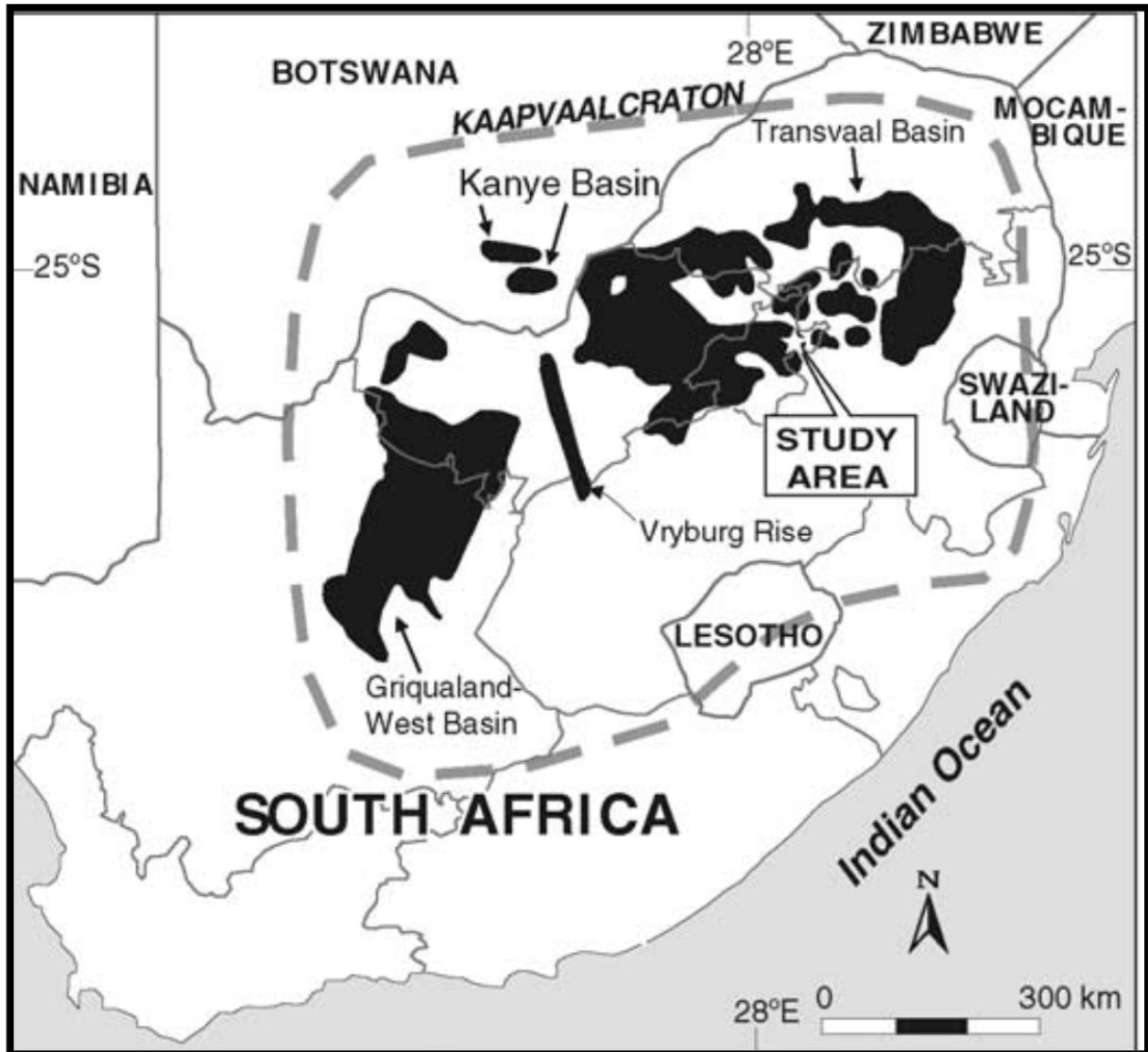

Figure 7.1: Sketch map showing preservation of the Transvaal Supergroup within three structural basins on the Kaapvaal craton, southern Africa: Transvaal itself and Griqualand West basins, South Africa, and the Kanye basin, Botswana. The study area of Parizot (et al., 2005) is indicated within the southern-central part of the Transvaal basin. Modified after Parizot (et al., 2005). The indicated study area is marked by Parizot (et al., 2005) and not applicable to this dissertation.

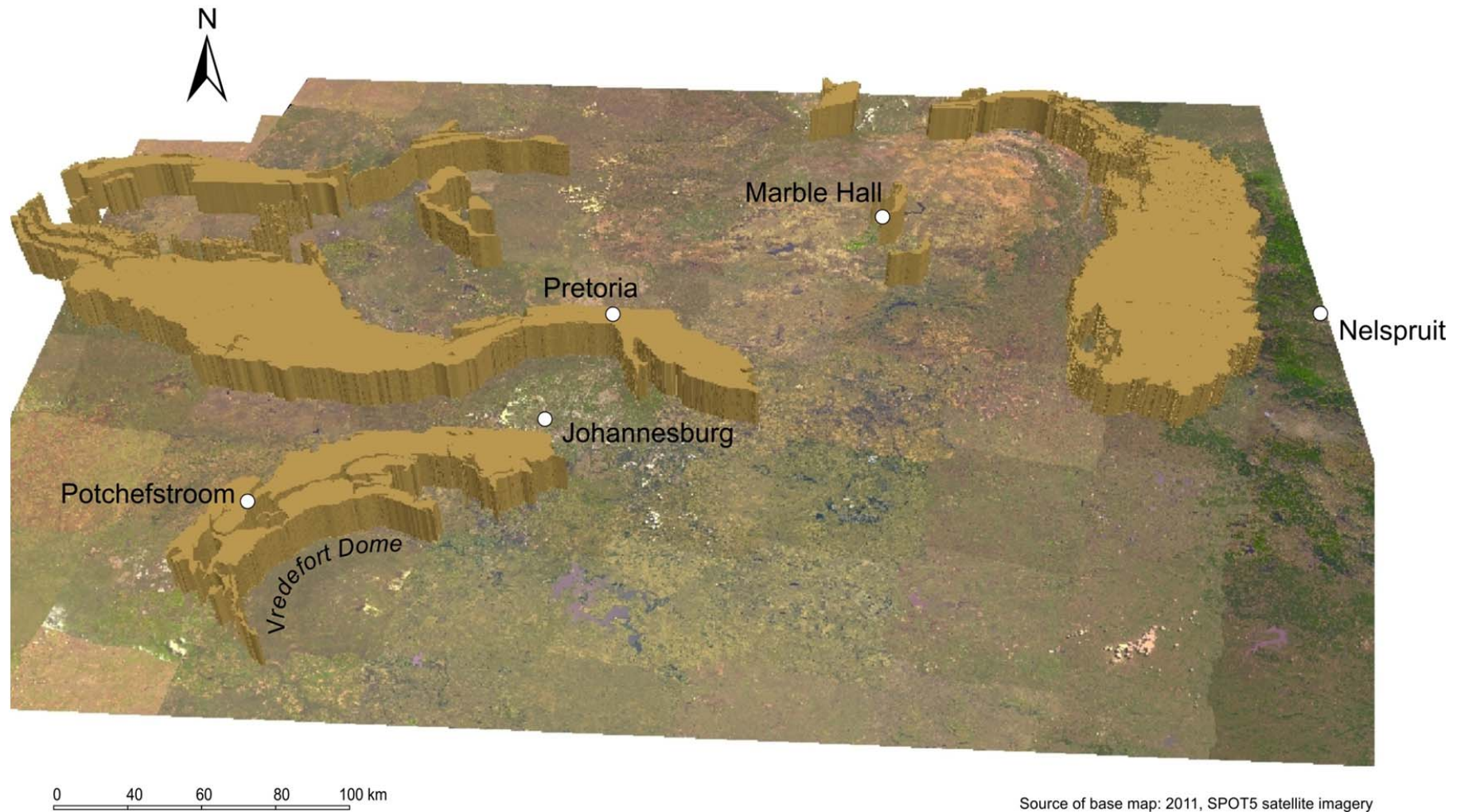

Figure 7.2: The Pretoria Group displayed by means of vertical exaggeration at an oblique angle using SPOT imagery. Courtesy of UP Geography department.

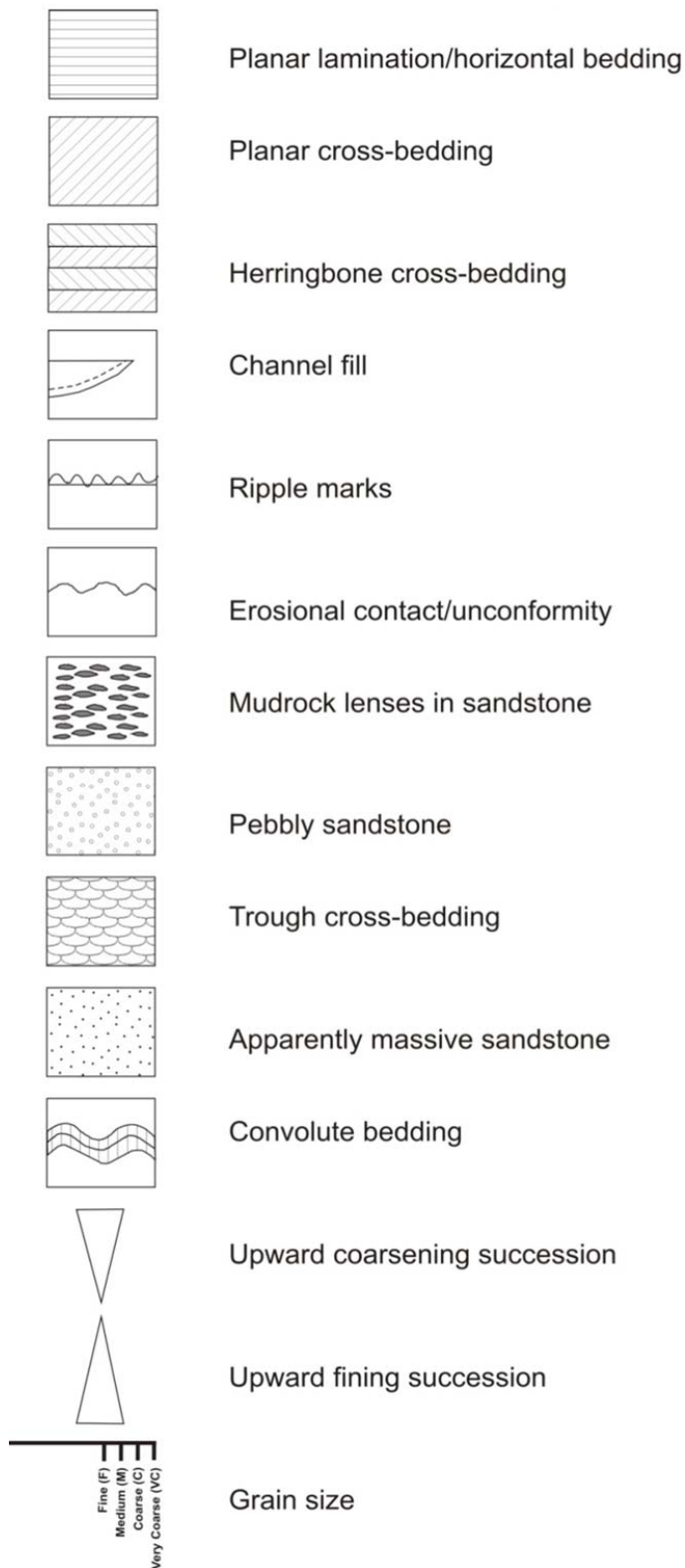

Figure 7.3: Legend of field outcrops. Note the horizontal grain size bar.

S 25°49.998'
E 28°22.709'
ELEVATION : 1431m

SWAVELPOORT

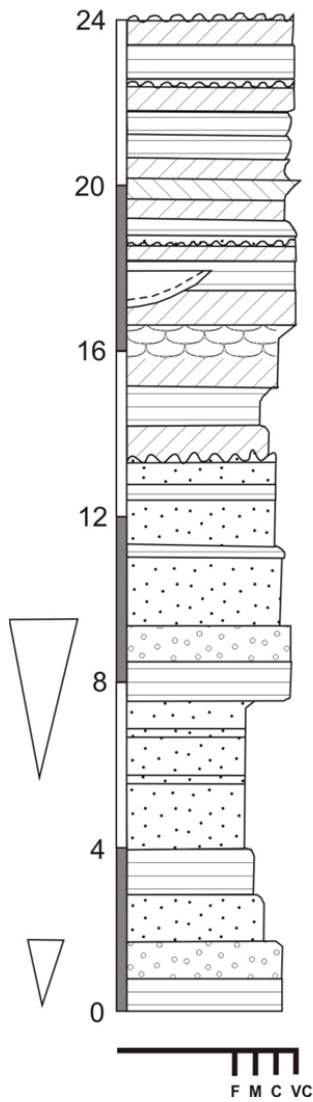

Figure 7.4: Swavelpoort outcrop, east of Pretoria.

S 25°18.012'
E 25°49.070'
ELEVATION : 482m

EAST OF GOPANE

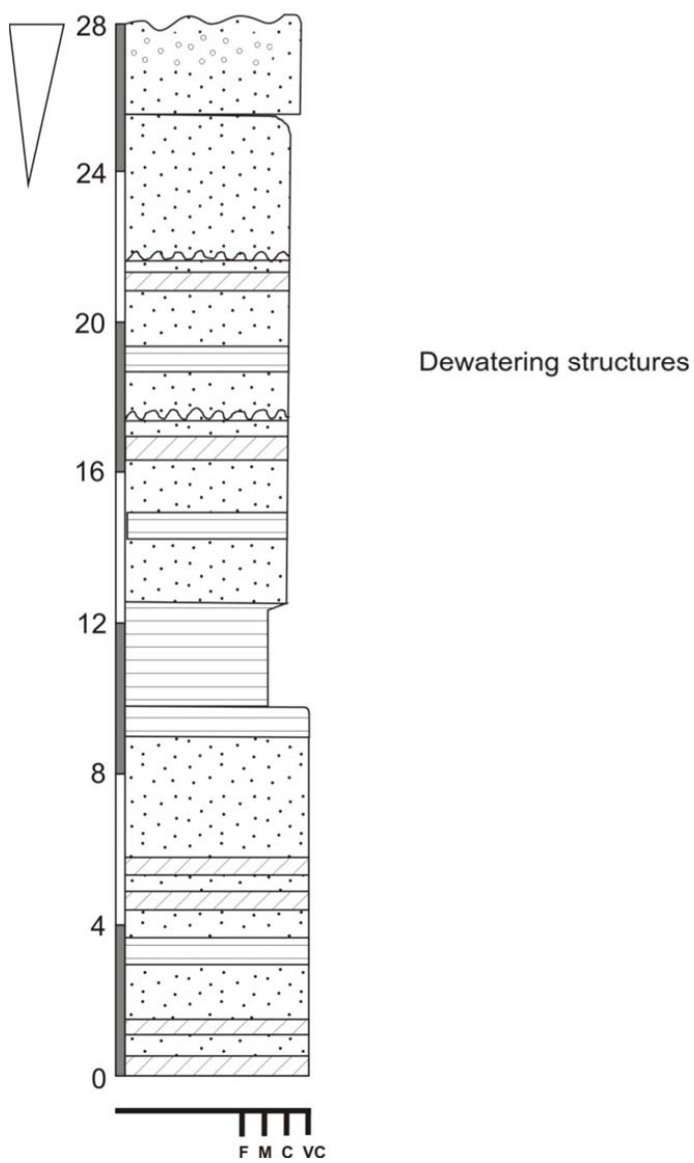

Figure 7.5: East of Gopane outcrop, near Botswana border.

S 25°46.276'
 E 28°18.101'
 ELEVATION : 1492m

FAERIE GLEN NATURE RESERVE

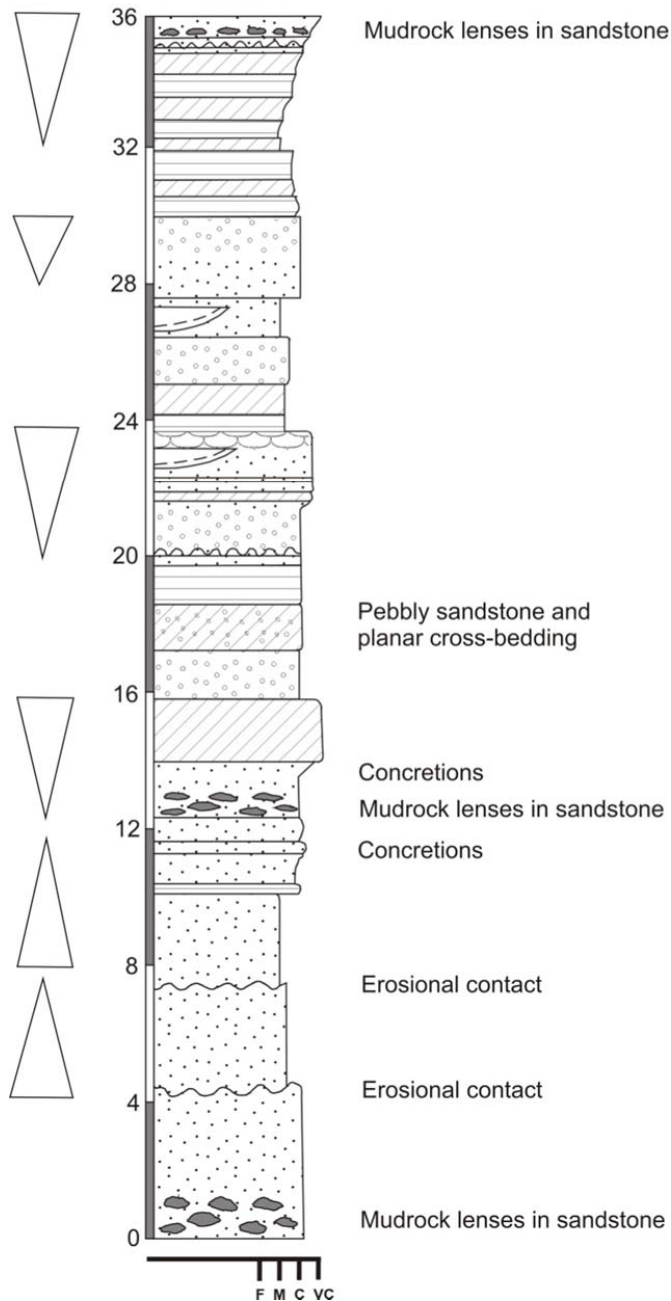

Figure 7.6: Faerie Glen outcrop, Pretoria East. Note the dominant upward coarsening trend.

S 25°54.954'
E 27°37.317'
ELEVATION : 1334m

HEKPOORT

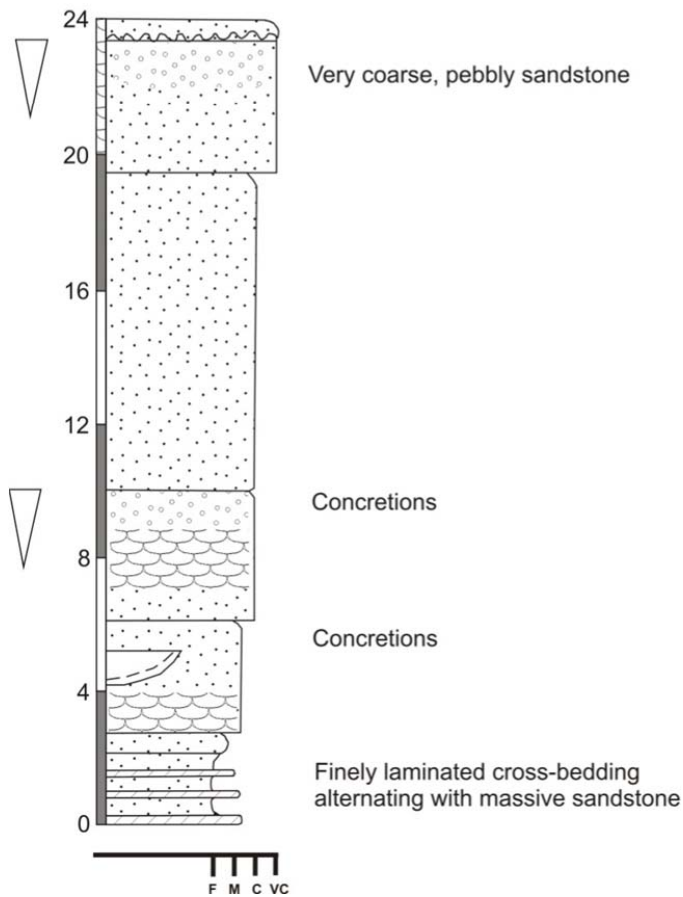

Figure 7.7: Hekpoort outcrop, west of Gauteng.

S 25°28.972'
E 26°53.032'
ELEVATION : 1142m

HOËBOME AFDRAAI

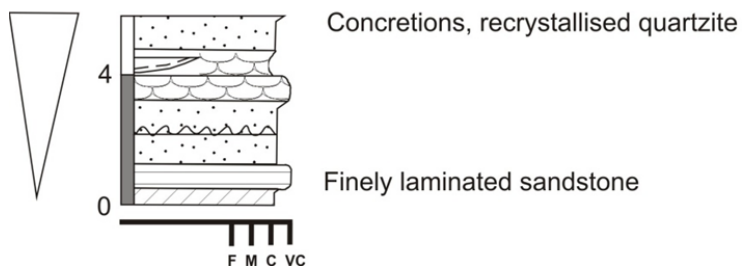

Figure 7.8: Hoëbome outcrop, west of Rustenburg, North west Province.

KAALBOOI, WATERVAL-BOVEN

S 25°40.957'
 E 30°22.296'
 ELEVATION : 1689m

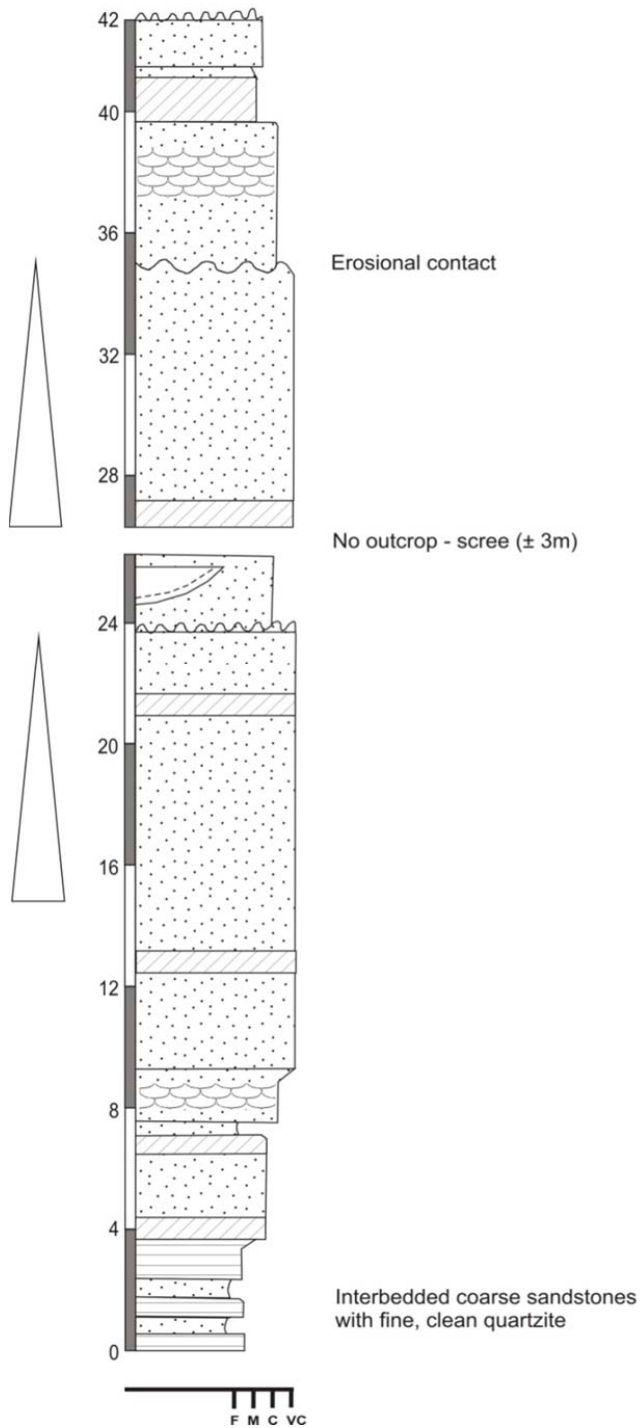

Figure 7.9: Kaalbooi outcrop, near eastern Drakensberg escarpment.

KOSTER

S 25°50.109'
E 26°54.631'
ELEVATION : 1492m

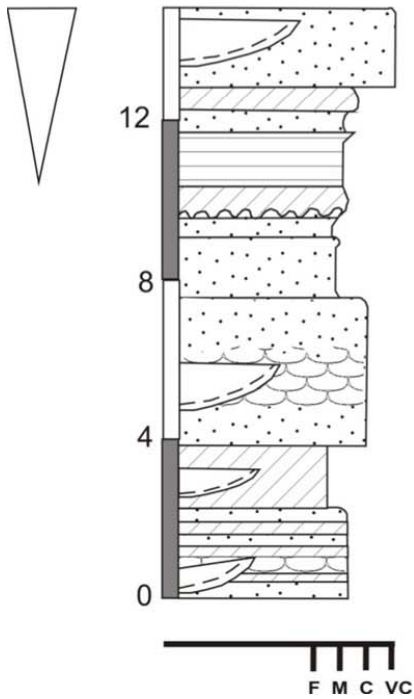

Figure 7.10: Koster outcrop, north of Koster.

STERKSPRUIT, LYDENBURG

S 25°08.00'
E 30°29.80'
ELEVATION : 1793m

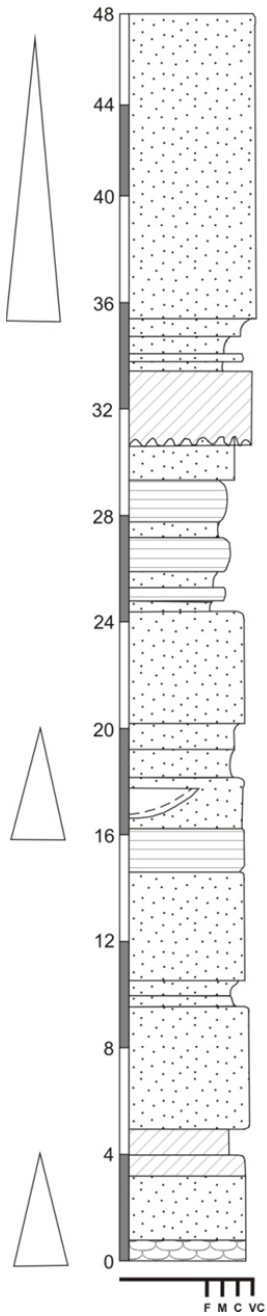

Figure 7.11: Sterkspruit outcrop, south of Lydenburg.

S 25°18.009'
E 25°49.961'
ELEVATION : 1155m

MOTHLABENG

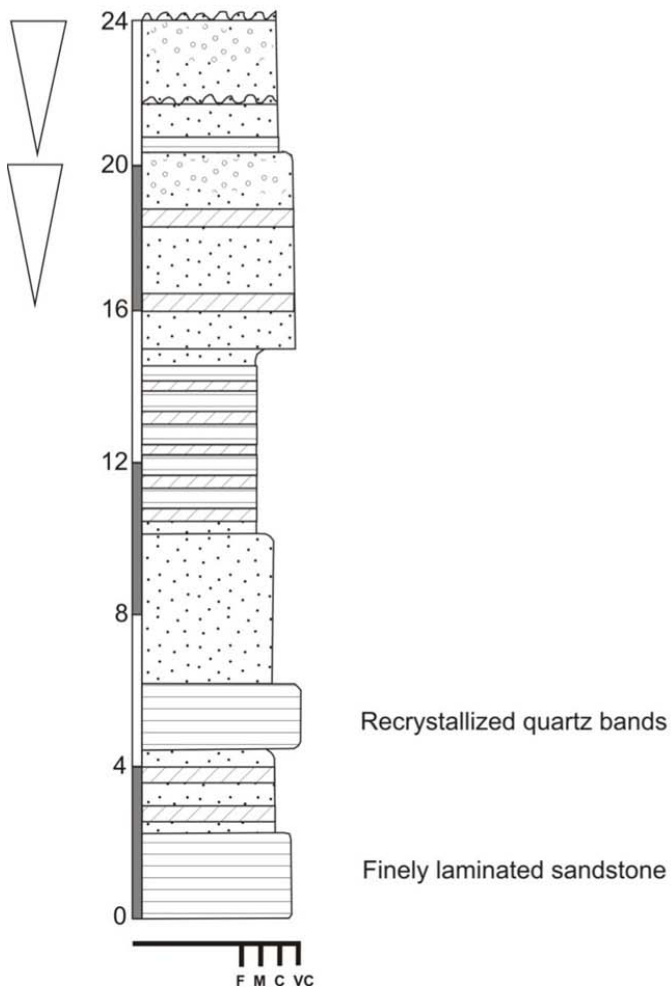

Figure 7.12: Mothlabeng outcrop, near Botswana border.

S 25°52.955'
E 28°25.282'
ELEVATION : 1409m

NKWE

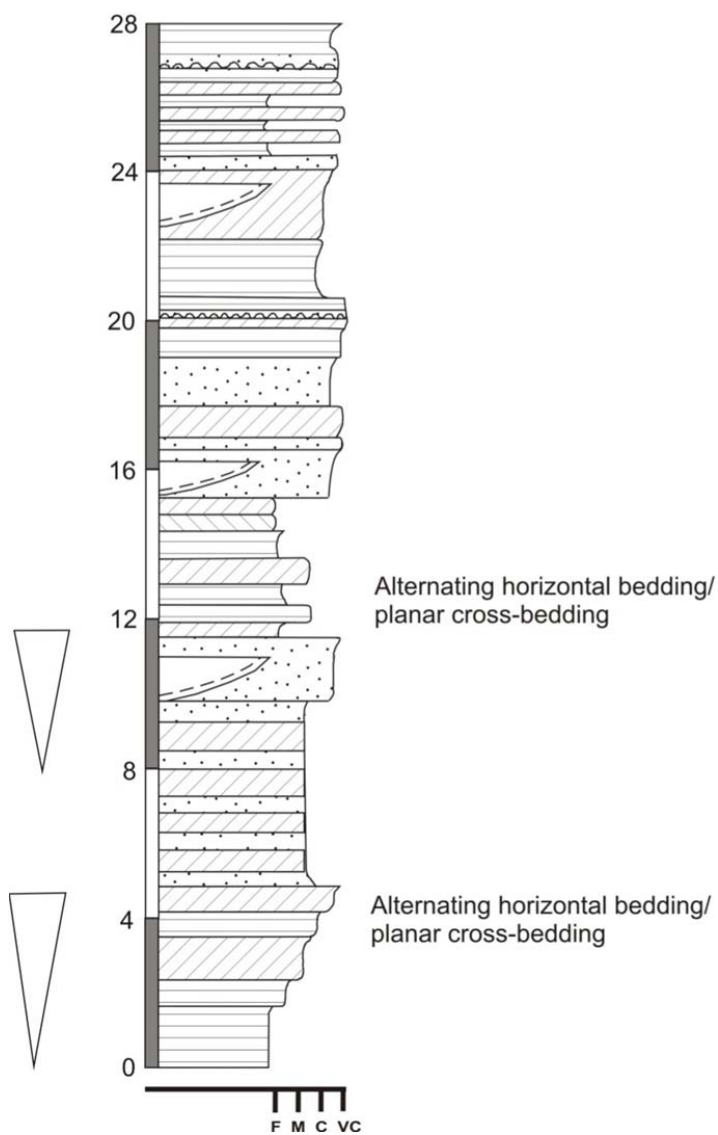

Figure 7.13: Nkwe outcrop, east of Pretoria.

PAUL KRUGER STREET, PRETORIA

S 25°43.892'
E 28°11.287'
ELEVATION : 1345m

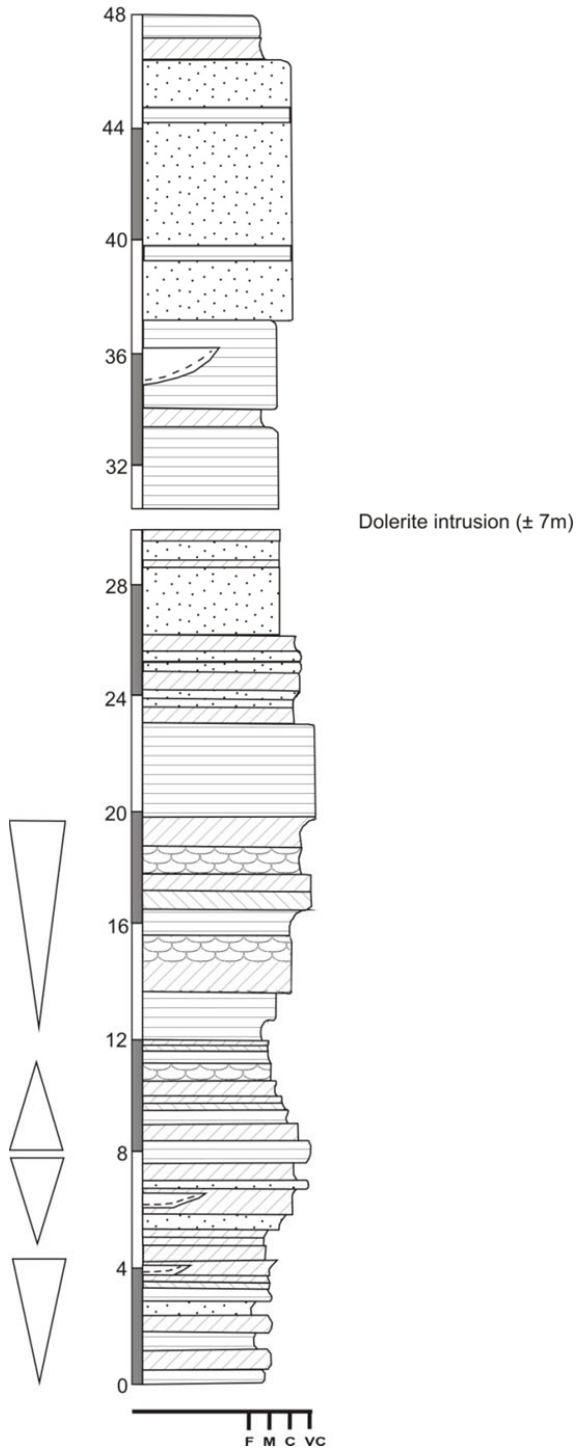

Figure 7.14: Paul Kruger Street outcrop, near Pretoria CBD.



Figure 7.15: Saartjiesnek outcrop, west of Pretoria.

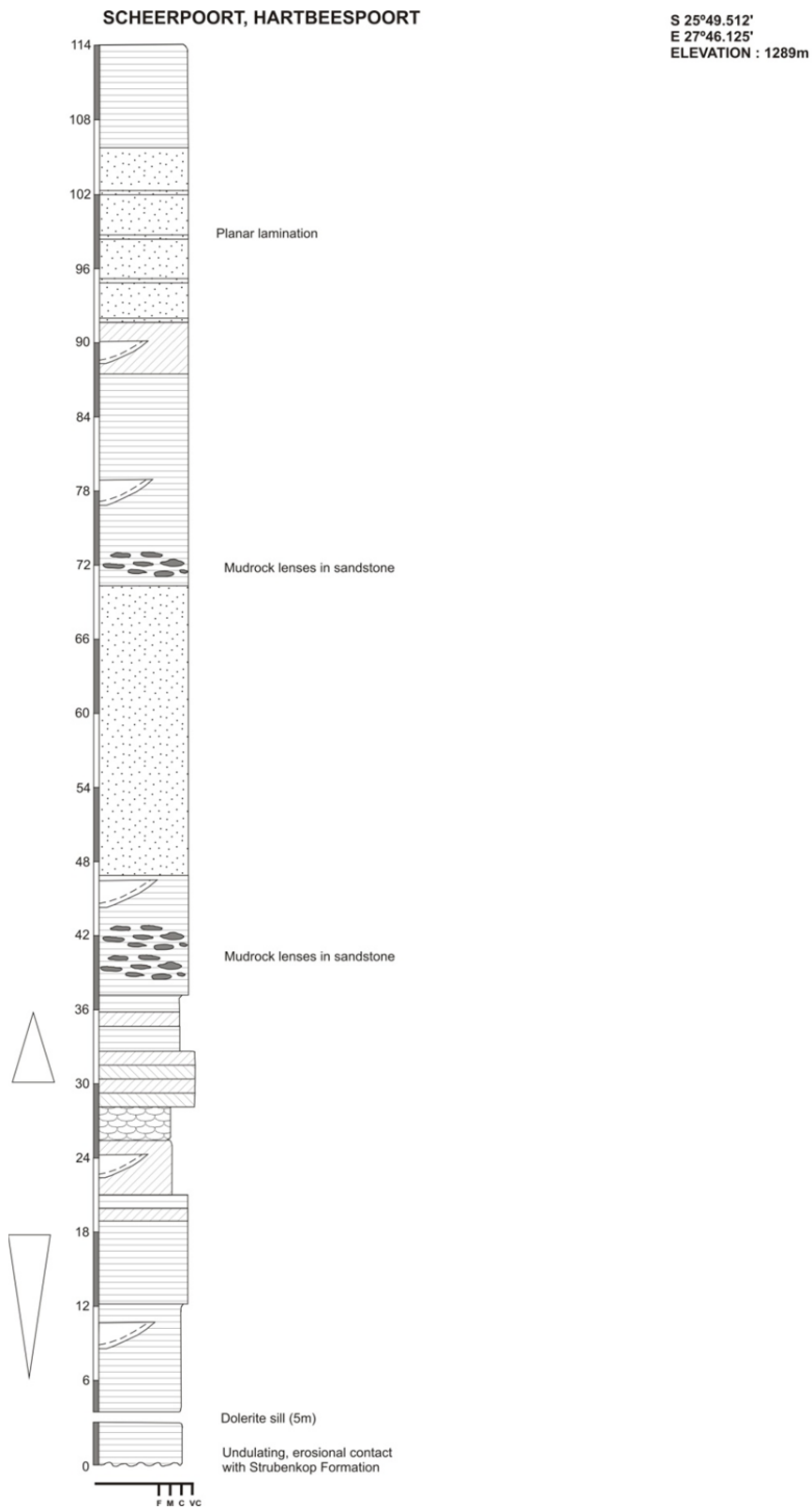

Figure 7.16: Scheerpoort outcrop, west of Pretoria.

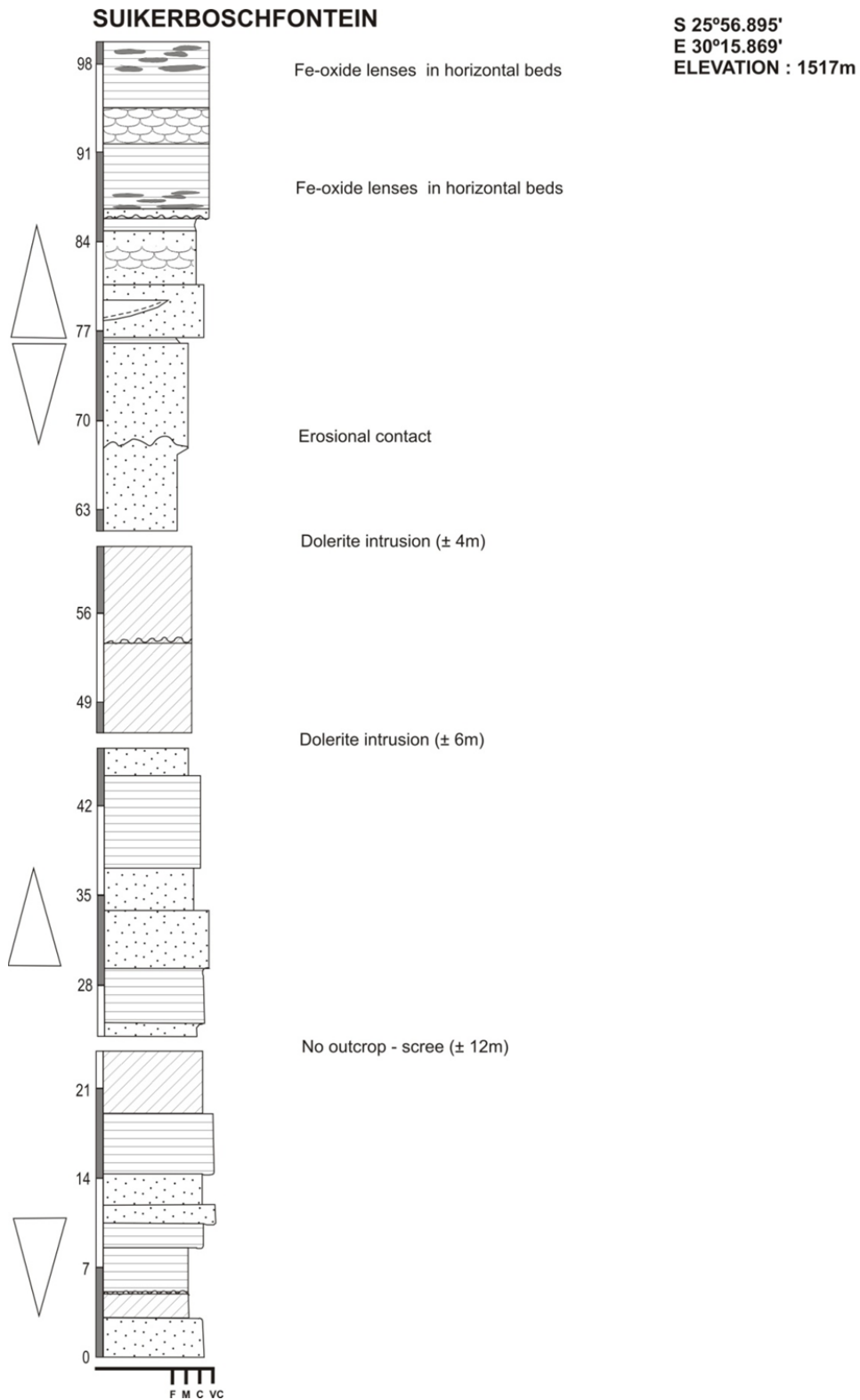

Figure 7.17: Suikerboschfontein, north east of Carolina.

S 25°44.194'
E 28°14.494'
ELEVATION : 1368m

SOUTPANSBERG ROAD, PRETORIA

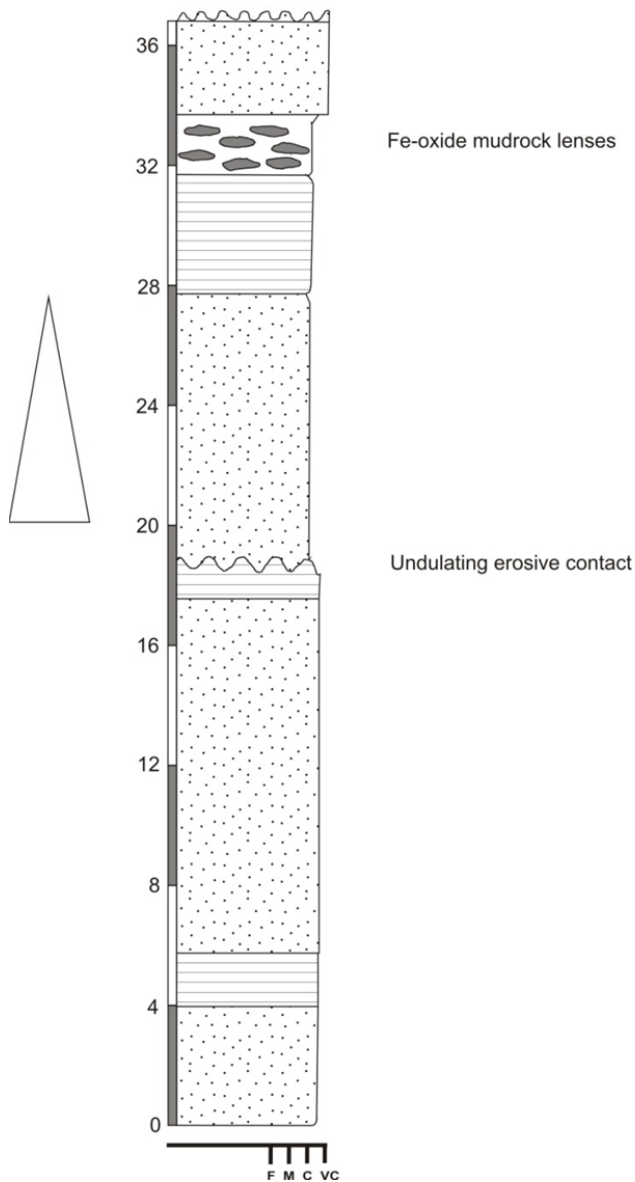

Figure 7.18: Soutpansberg Road outcrop, Pretoria.

Table 11: Ripple mark morphology. The dominant/average dip direction and angles are shown. Asymmetrical ripple marks are included although their interference pattern does deviate from the major strike direction.

Location	Major Strike Direction	Dip Direction	Dip angle	Symmetrical
Saartjiesnek	WNW - ESE	8	18	Yes
Paul Kruger	W - E	2	31	No
Nkwe	ESE - WNW	292	9	Yes/No
Soutpansberg	W - E	3	35	Yes
Suikerboschfontein	WNW - ESE	285	3	No
Faerie Glen	N - S	356	19	Yes/No
Hoëbome	WNW - ESE	318	21	No
Koster	ENE - WSW	80	8	No
Kaalbooi	WNW - ESE	309	2	No
Hekpoort	NNE - SSW	25	18	No
Mothlabeng	WSW - ENE	240	10	No
East of Gopane	SSE - NNW	150	7	Yes
Swavelpoort	N - S	7	10	Yes
Hans Strijdom	N - S	9	4	Yes

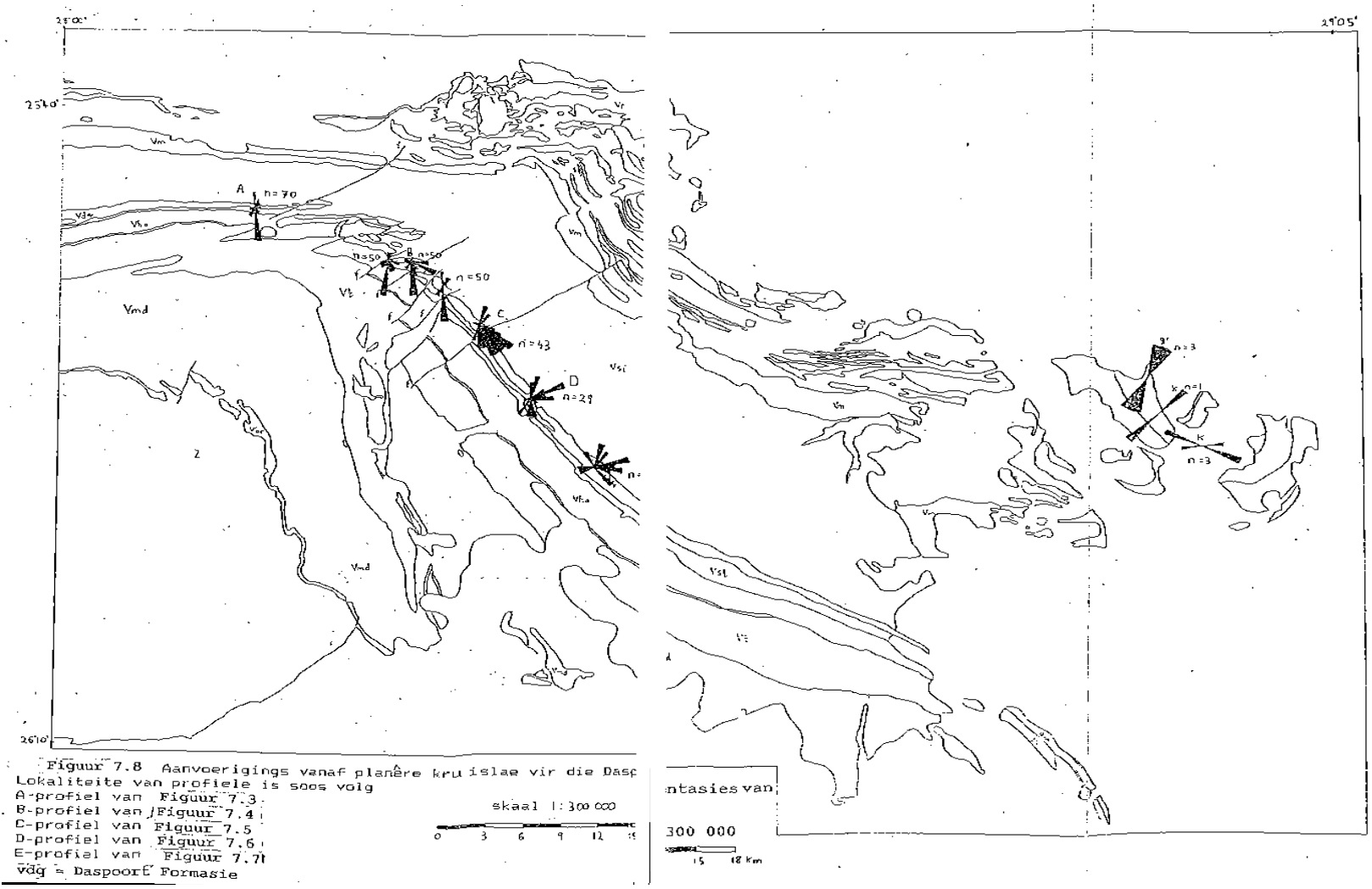

Figure 7.20: Sediment transport directions measured from planar trough cross-bedding in the Daspoort Formation, east of Pretoria. VSi = Silverton Formation, Vd = Daspoort Formation, Vm = Magaliesberg Formation, Vmd = Dwaalheuwel Formation. Image from Van der Neut (1990).

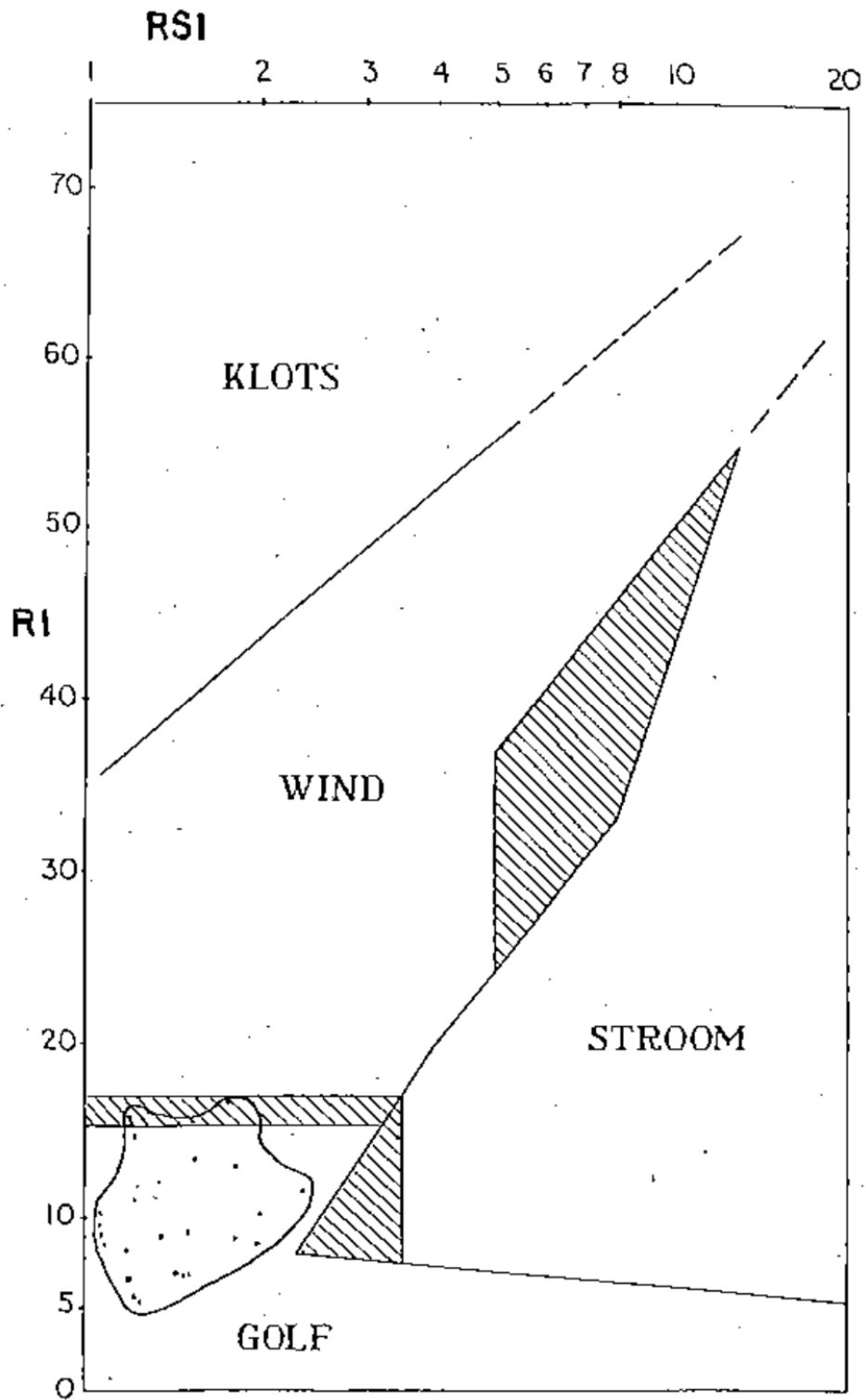

Figure 7.21: Ripple mark data as calculated by Van der Neut (1990).

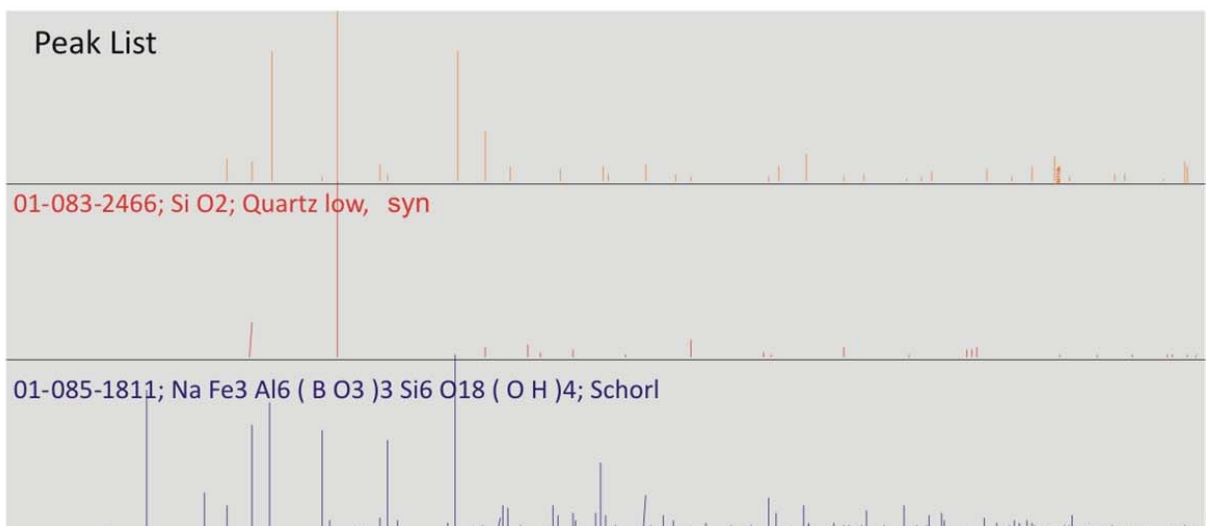
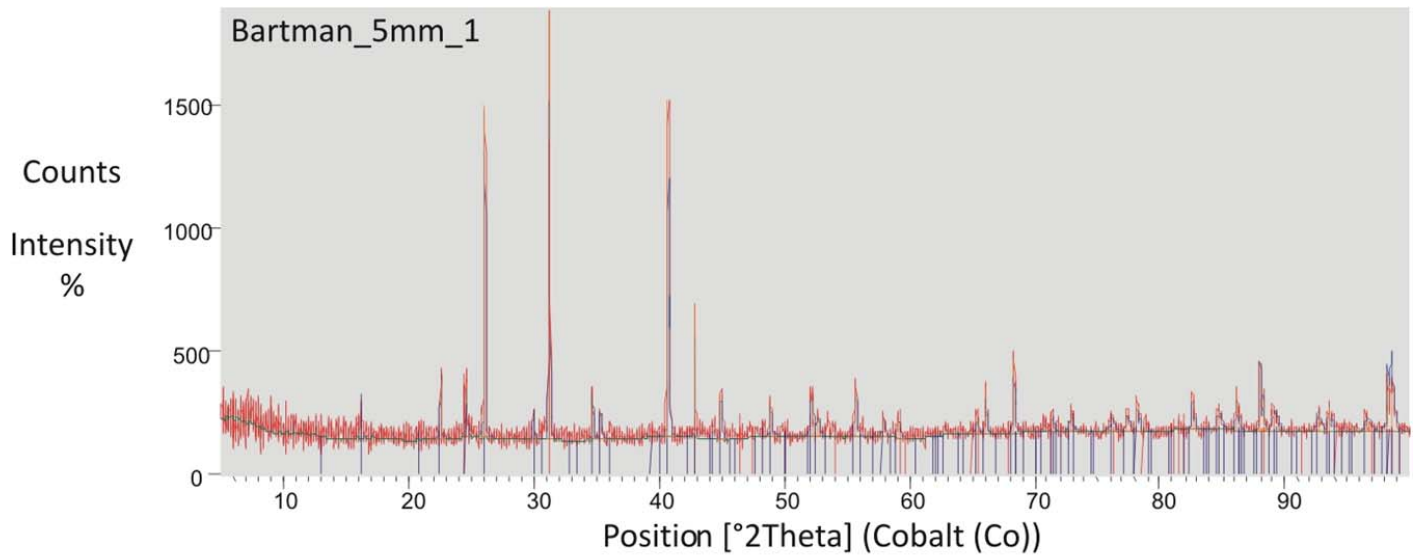

Figure 7.22: XRD Analyses - Dark microbial mat

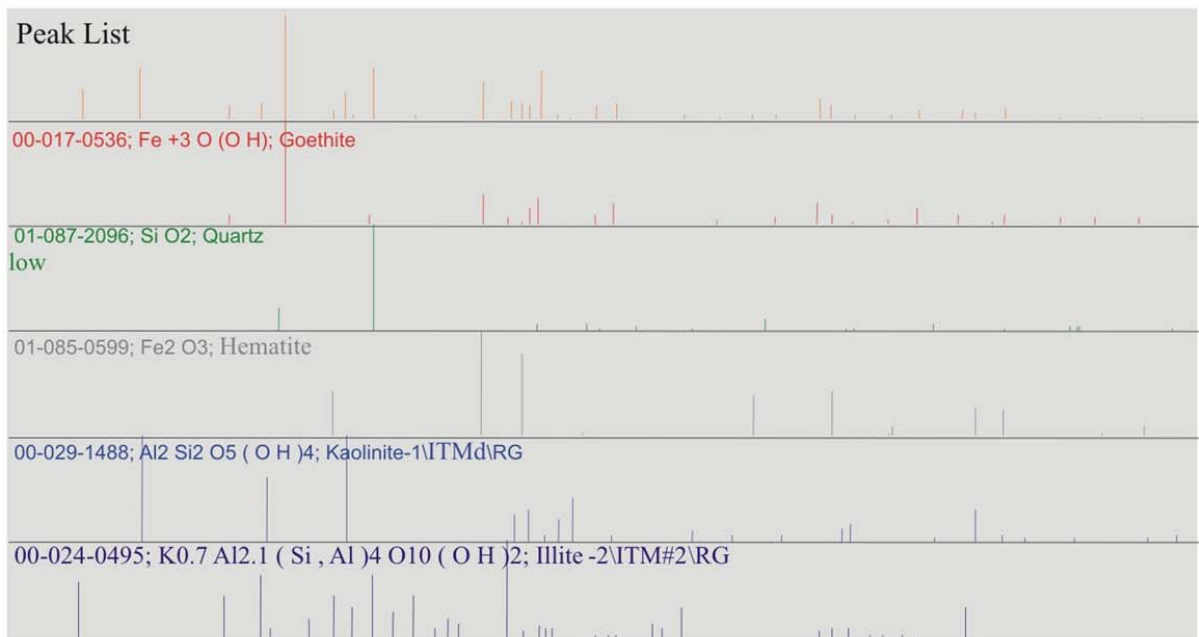
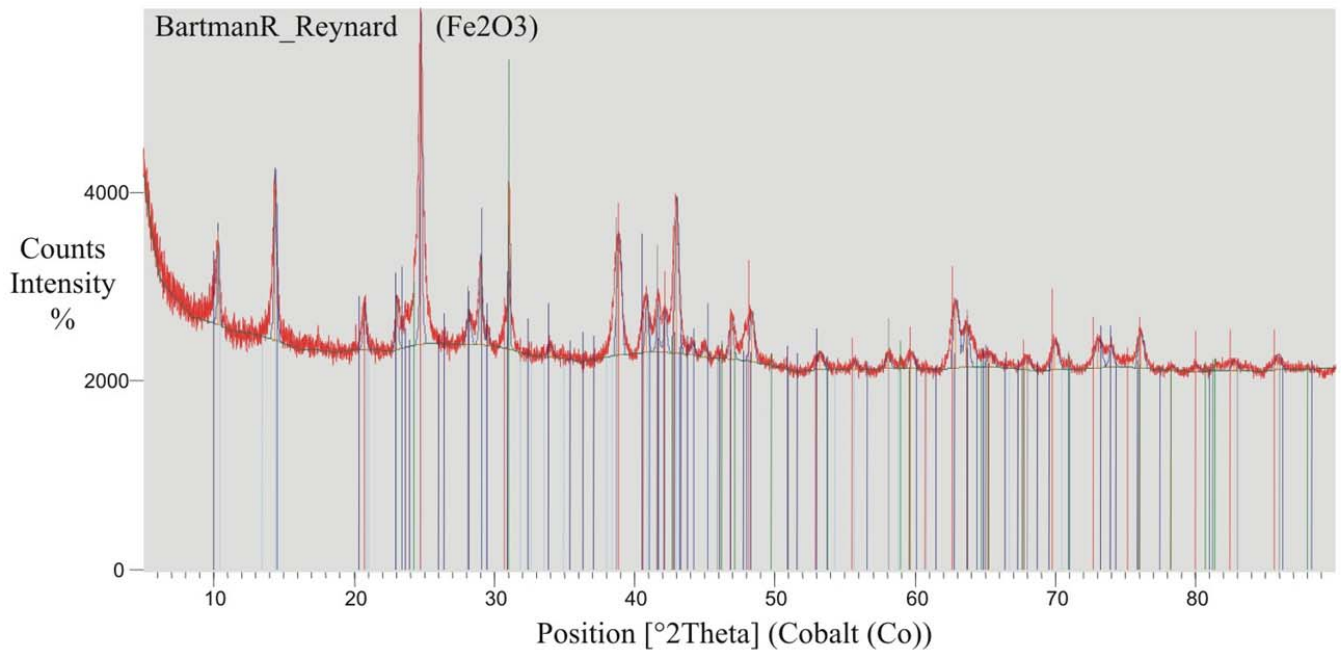

Figure 7.23: XRD Analyses - Mud layer.

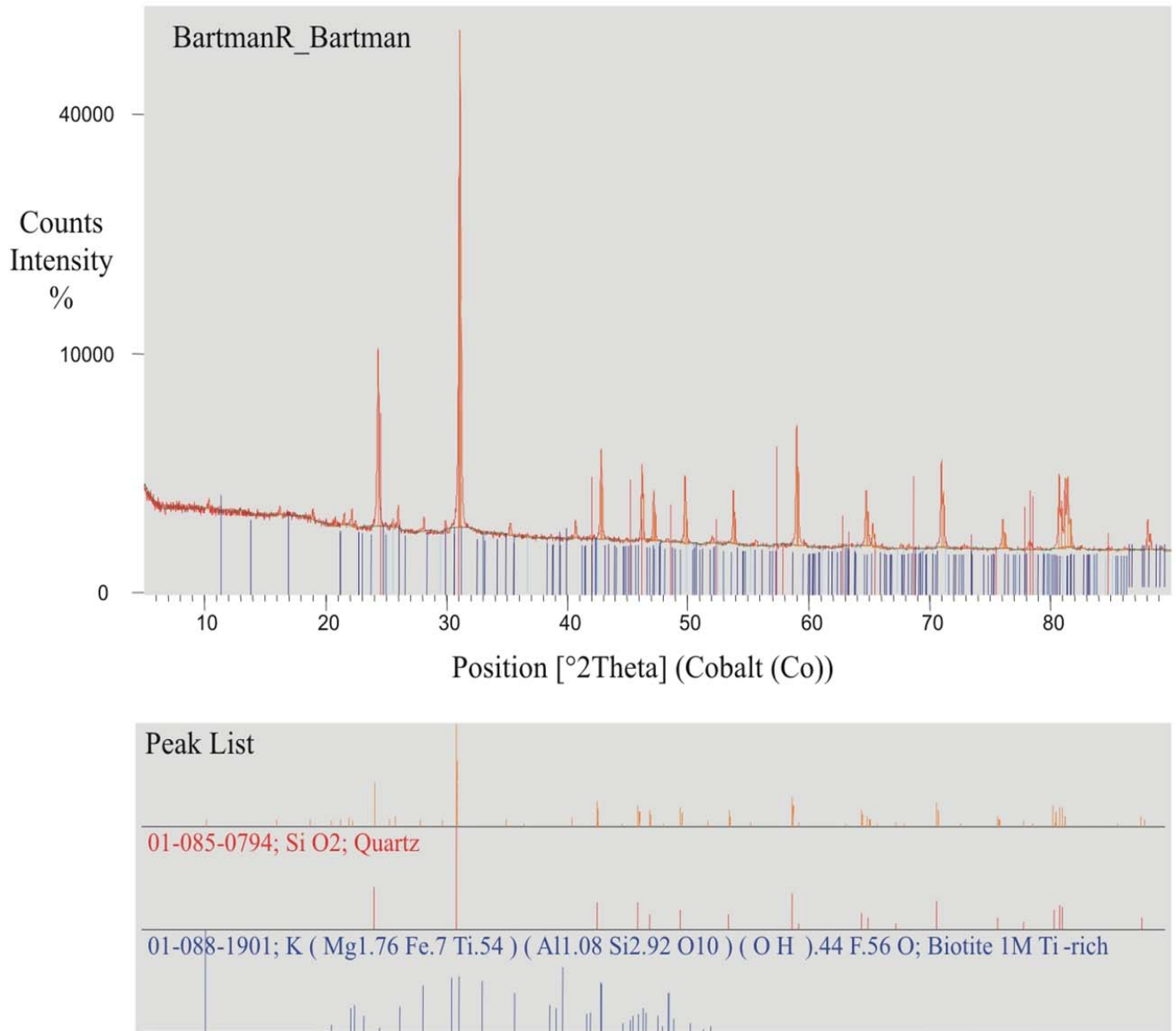

Figure 7.24: XRD Analyses - Whole rock

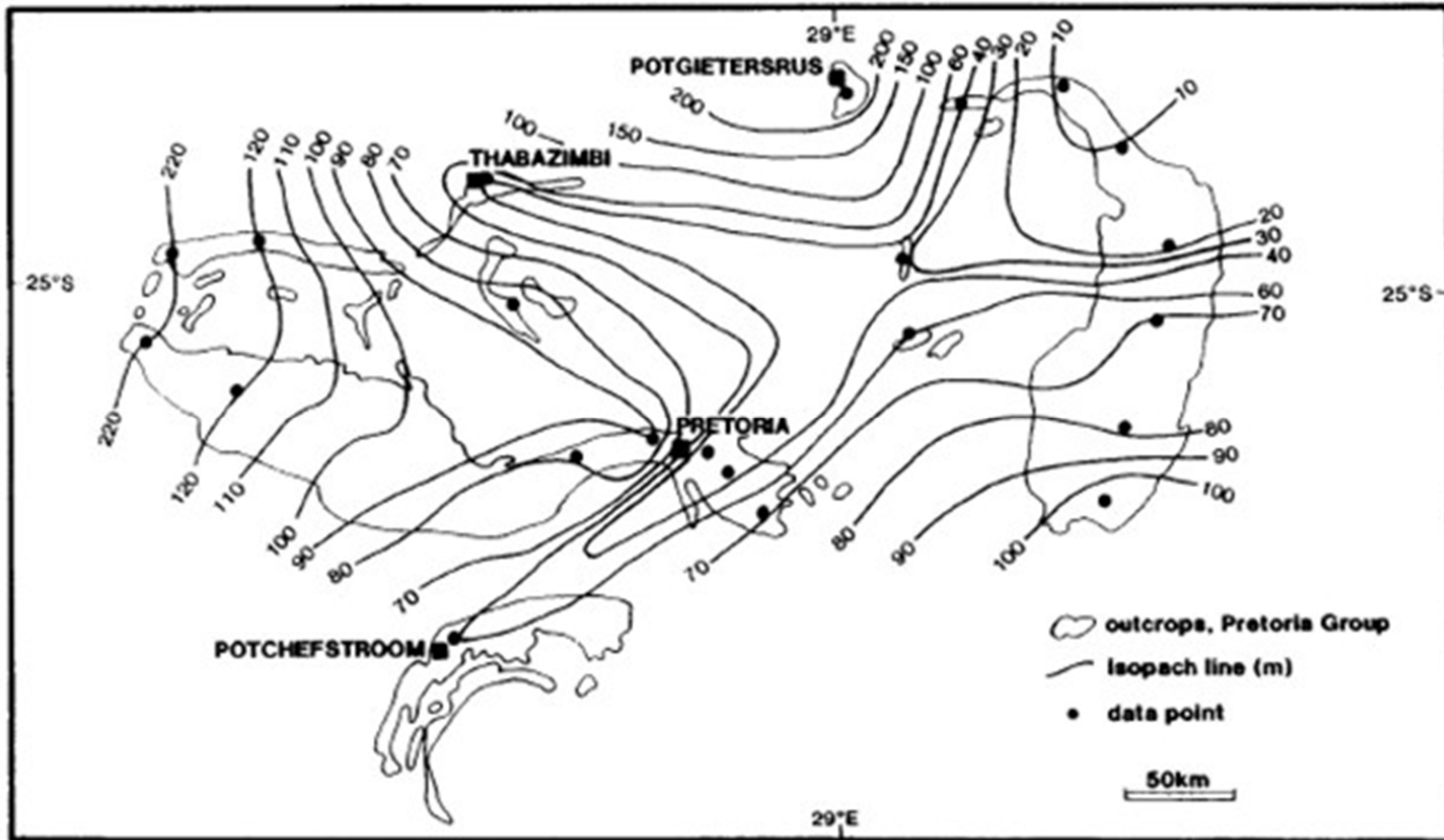

Figure 7.25: Isopach map of the Daspoort Formation. This is produced by Eriksson (1993) with supplementary data from Key(1983), Engelbrecht et al., (1986) and Hartzer (1989).

Table 12: Facies typical of fans and braidplain deposits (Miall, 1977; as modified by Miall, 1978 and Rust, 1978)

Major facies	Gm	Clast-supported, commonly imbricate gravel with poorly defined sub horizontal bedding
	Gms	Muddy matrix supported gravel without imbrications or internal stratification
	Gt	Trough cross bedded clast supported gravel
	Gp	Planar cross-bedded gravel, transitional from clast-supported gravel through sand matrix –supported gravel to sand (Sp)
Minor facies	Sh	Horizontally stratified sand
	St	Trough stratified sand
	Sp	Planar cross-stratified sand
	Fm	Massive fine sandy mud or mud
	Fl	Laminated or cross-laminated very fine sand, silt or mud
	P	Pedogenic concretionary carbonate

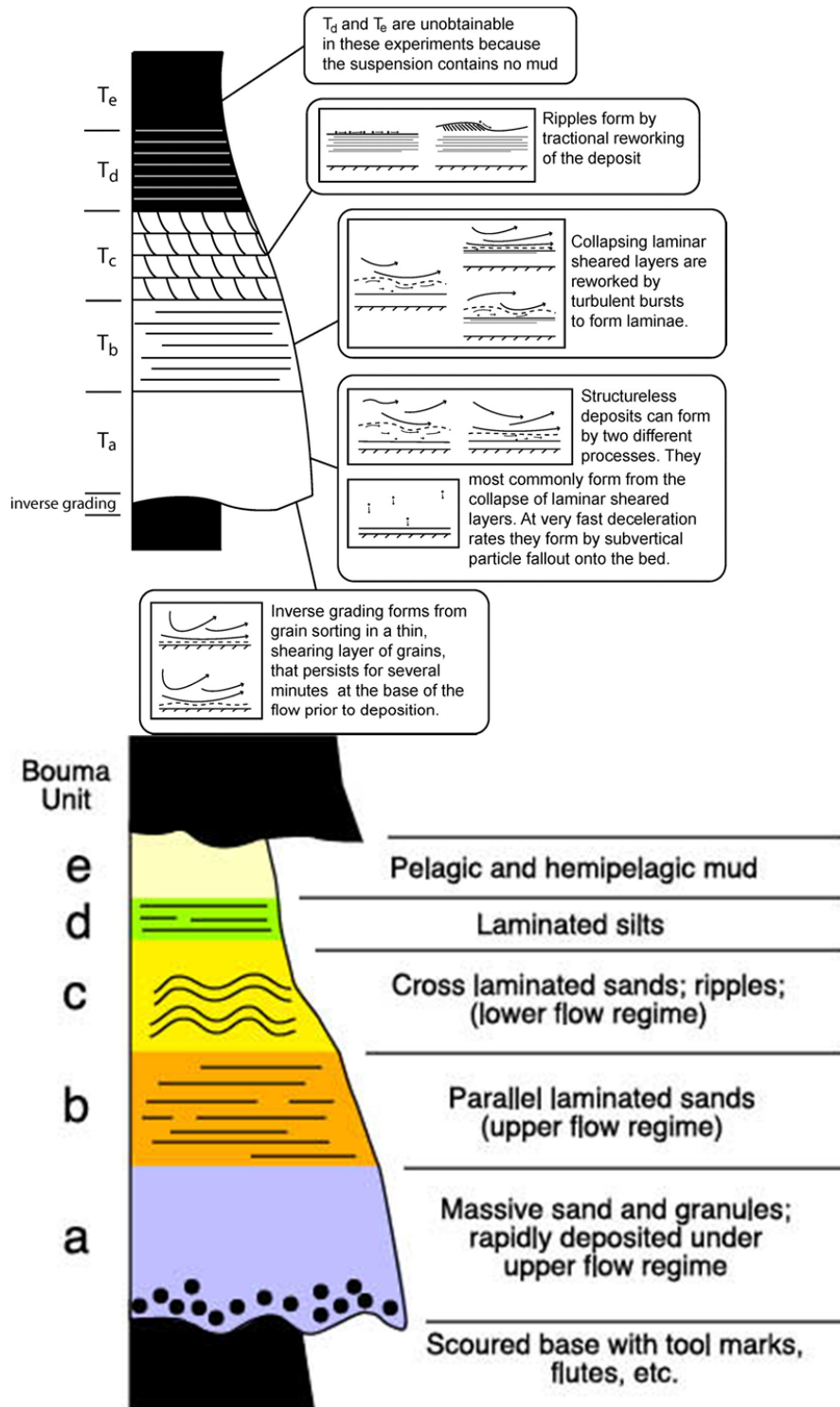

Figure 7.26: Turbite succession (left) compared to the Bouma sequence (right). Modified after Bouma (1982).