

ULTRA-DOWNSIZING OF INTERNAL COMBUSTION ENGINES: SIMULTANEOUS INCREASING OF THERMAL CONVERSION EFFICIENCY AND POWER WHILE REDUCING EMISSIONS

Victor GHEORGHIU*

Department of Mechanical Engineering,
Hamburg University of Applied Sciences, Germany,
E-mail: victor.gheorghiu@haw-hamburg.de

ABSTRACT

The Downsizing of internal combustion engines (**ICE**) is already recognized as a very suitable method for the concurrent enhancement of the indicated fuel conversion efficiency (**IFCE**) and lowering of the CO₂ and NO_x emissions [1], [2].

In this report the Ultra-Downsizing is introduced as a still higher development stage of ICE. The Ultra-Downsizing will be implemented here by means of real Atkinson cycles, using asymmetrical crank mechanisms, combined with a very intensive multistage high-pressure turbocharging with intensive intercooling. This will allow an increase of ICE performance while keeping the thermal and mechanical strain strength of engine components within the current usual limits.

INTRODUCTION

The scarcity of the available oil and gas reserves and the global warming phenomenon urge together the automotive industry toward a decrease in fuel consumption and thus a reduction of CO₂ emissions. These factors will also determine the future R&D trends for ICE.

Downsizing of ICE means the simultaneous decreasing of the displaced volume (usually by reducing the number of cylinders) and increasing of the indicated mean pressure (**IMEP**) by means of turbocharging [1], [2]. This allows the preservation of power and torque performance while decreasing the engine size. Thereby a) the mechanical and thermal losses are reduced, b) the engine becomes lighter, leading to a drop in the overall weight of the vehicle, and c) the engine operates more time within its optimum fuel consumption zone. The advantages offered by a) and b) hold true even for ICE used in hybrid propulsion systems, while the advantage c) is already a feature of the full-hybrid vehicles.

The level of downsizing determines the strength of the thermal and mechanical strains of the engine components. In order to avoid exceeding the usual limits, either the boost pressure or the volumetric compression ratio (**VCR**) must be reduced accordingly. As consequence, the whole potential of downsizing are not achieved and the IFCE and IMEP remain at low level.

The current ICEs have classical (symmetrical) crank mechanisms (i.e. with compression and expansion strokes of equal length) and follow the Seiliger cycles. Real implemented

Atkinson cycles require unequal strokes featuring a shorter compression stroke, which leads to a higher IFCE [3]. Atkinson cycles have been used so far mostly with symmetrical crank mechanisms, where the intake valves are closed very late in the cycle [4]. Thus, a part of the charge sucked into cylinder is push back to the intake pipes and the effective compression stroke is decreased. This quasi implementation of Atkinson cycles shows no noticeable improvements of the IFCE and, hence, it will not be discussed in the course of this paper [3].

Real Atkinson cycles can be implemented only with the help of asymmetrical crank mechanisms. This allows to use concurrent very high boost pressures (to increase the IMEP) and higher VCR (to enhance the IFCE) and to set them much more independently of each other compared to Seiliger cycles [3]. Because an important part of the fresh charge compression takes place beyond the cylinder, the high compressed fresh charge can be cooled intensively before it is sucked in cylinder. The following moderate compression in the cylinder (i.e. with relative lower VCR) lead to lower temperature peaks during the combustion process and, consequently, to less NO_x emissions.

This approach has already been proved in several previous theoretically investigations based on ideal Seiliger and Atkinson cycles [3]. These investigations did not take into consideration the effect of heat exchange and frictional losses on the cycle in order to make it easier to check the solution and to draw a comparison between the Seiliger and Atkinson cycles. The performances achieved for IFCE and IMEP using this method are therefore unrealistically high and serve only as a general indication [3].

This Paper extends the previous investigations from [3] to real Atkinson cycles by using the simulation tool BOOST (AVL Co). This tool allows to take into consideration the true geometrical dimensions of the engine components (cylinder, valves, channels, pipes, manifolds, turbocharger, intercooler, silencer etc.) and the losses caused by friction and heat transfer along the intake and exhaust gas pipes. In addition, the power balance of turbochargers determines the actual boost pressure level of the engine.

The turbochargers (**TC**) are modeled for these investigation in a simple manner. It describes the expansion process in the turbines (**Tx**) by means of their discharge coefficients while the air compaction in the compressors occurs up to a maximum

pressure ratio, which depends on the available turbine output. To be able to simulate cycles with very high boost pressures as well, three intercooled TC are placed in line (three-stage turbocharging, see Fig. 1). When the boost pressure required for preserving the pressure limit on the cycle is low, the superfluous TC are kept in use (i.e. are not bypassed). The expansion and compression ratios of the turbines and compressors tend gradually toward 1, i.e. these TC switch off themselves thermodynamically.

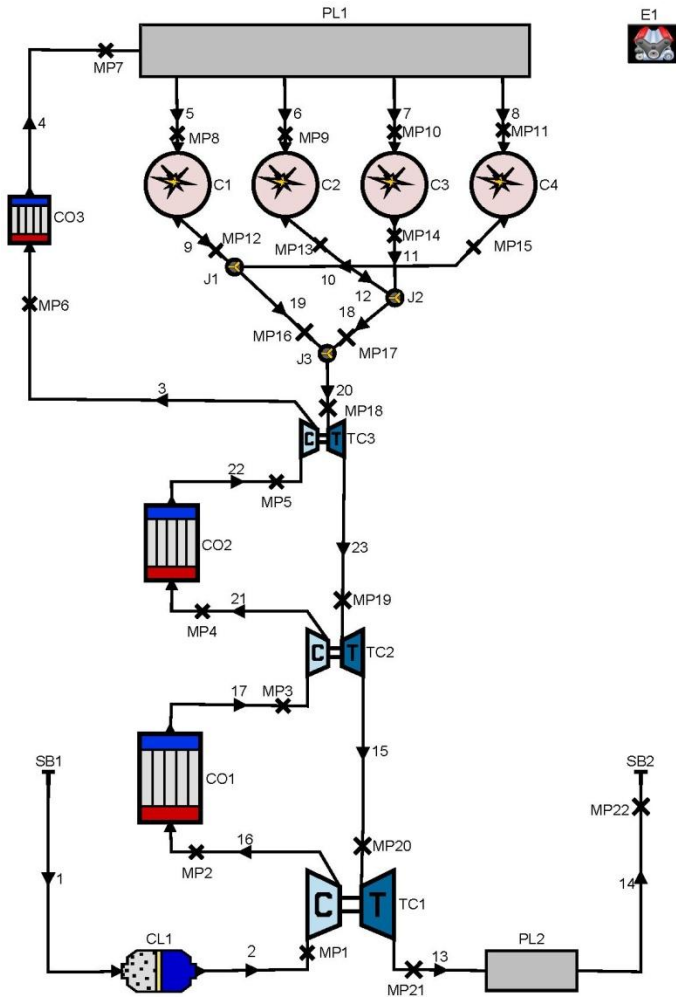

Figure 1 BOOST Model of a four cylinder TC engine
Simple number denote pipes, Cx = cylinder, COx = cooler, TCx = turbochargers, PLx = plenum, Jx = junctions, CLx = cleaner, SBx = system boundaries, Ex = engine and MPx = measuring points

The asymmetrical crank mechanism used here can realize the classical piston displacements for the Seiliger as well as for the Atkinson cycles with various asymmetries between the compression and expansion strokes (see. Fig. 2).

As mentioned, in the case of the Seiliger cycle, the expansion and compression strokes are identical. The limitation of the maximum pressure during the cycle determines the pair of parameters VCR - boost pressure. If a relatively high boost pressure is desired, one must reduce the VCR accordingly in order to accomplish the maximum pressure limitation on the

cycle. This will also decrease the IFCE, since it is determined primarily by the VCR. Furthermore, the expansion in the cylinder occurs largely incomplete and the exhaust gases exit the cylinder with still too high specific enthalpy, which decreases furthermore the IFCE. However, the expansion of exhaust gases in the turbines with its high specific enthalpy can be used only partly for driving the compressors and, therefore, for enhancing the boost pressure, because exceeding of the pressure upper limit during the cycle.

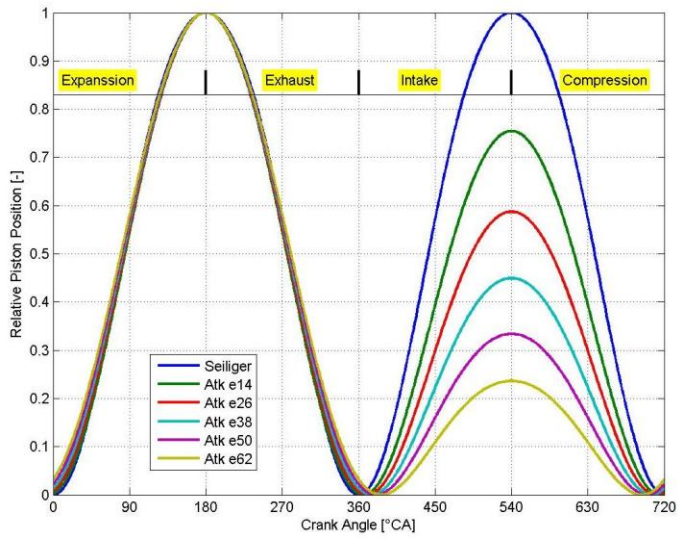

Figure 2 Relative Displacements of the used Asymmetrical Crank Mechanism
The Atkinson (Atk) cycles are implemented by means of variation of the eccentric radiuses **exx** of the used crank mechanism. The Seiliger cycle is realized with zero eccentric radius.

One can summarize the facts as follows:

- To raise the IFCE, the most part of the working gas expansion should occur within cylinder.
- If, however, the expansion process within cylinder occurs completely (a complete expansion occurs up to the ambient pressure, in an ideal case), then no more boost pressure can be generated.
- In order to increase the expansion part within cylinder, the crank mechanism must provide a higher VER. This makes a long expansion stroke (and therefore an engine with a high piston displacement) necessary. However, that lead to high IFCE but quite low indicated specific power (kW/liter) of the engine.
- If one wanted to raise simultaneously the IFCE and the indicated specific power, the engine must be turbocharged and the ratio between the expansions within the cylinder and within the turbines (i.e. between internal and external expansion) must be optimized.
- To be able to optimize the ratio between internal and external expansions, regardless of VCR, one needs an asymmetrical crank mechanism and therefore, to implement real Atkinson cycles.

Several variants of the asymmetrical piston displacement are displayed in Fig. 2. These variants are based on a steady

VER and a varied VCR, which allows the modification of the ratio between internal and external expansion. The goal of this Paper is to look for the optimum ratio between internal and external expansion, which leads simultaneously to maximizing the IFCE and enabling sufficiently high values of IMEP.

SETTINGS OF THE SIMULATIONS

The simulations of the piston displacements presented in Fig. 2 are carried out using the BOOST model from Fig. 1. The parameters and the performance of seven cycles are shown in Table 1. Many of the parameters from all cycles were kept identical in order to make comparison easier.

Most parameters of the BOOST model were selected for a hypothetical engine and are kept unchanged for all simulations. Among these are the following parameters:

- All geometrical dimensions (with the exception of the crank mechanism)
- Valve timing
- Wall temperatures, heat transfer coefficients, efficiencies and pressure losses of the intercoolers, friction coefficients in the pipes
- Blow by gap size of cylinder, frictional characteristic curve of the engine etc.

A simple Vibe function was selected in order to model the combustion process. The different positions of the TDC in the Atkinson and Seiliger cycles (see Fig. 2 and 5) are compensated by choosing a suitable start of combustion (SOC), so that combustion begins in all cycles uniformly at 5°CA before TDC.

Cycle	VER	VCR	μ_{T1}	μ_{T2}	μ_{T3}	n	AFR	SOC	CD	m_{vibe}
	-	-	-	-	-	rpm	kg/kg	°CA	°CA	-
Atk e14	27,0	20,6	0,490	0,264	0,164	3000	14,6	-30	86	1,5
Atk e26	27,0	16,2	0,410	0,220	0,137	3000	14,6	-30	86	1,5
Atk e38	27,0	12,7	0,330	0,177	0,111	3000	14,6	-30	86	1,5
Atk e50	27,0	9,7	0,270	0,145	0,090	3000	14,6	-30	86	1,5
Atk e62	27,0	7,1	0,210	0,113	0,070	3000	14,6	-30	86	1,5
Seiliger	7,0	7,0	0,280	0,151	0,094	3000	14,6	-5	86	1,5
Seiliger	15,0	15,0	0,500	0,269	0,168	3000	14,6	-5	86	1,5

Cycle	VER	VCR	IFCE	IMEP	max(p)	max(T)	p_{MP8}	T_{MP8}	p_{MP12}	T_{MP12}
	-	-	-	bar	bar	K	bar	K	bar	K
Atk e14	27,0	20,6	0,411	20,3	243	2252	2,41	328	2,31	811
Atk e26	27,0	16,2	0,422	23,6	237	2206	3,39	337	3,20	838
Atk e38	27,0	12,7	0,423	29,6	251	2184	5,45	347	5,12	885
Atk e50	27,0	9,7	0,411	31,8	230	2171	7,91	352	7,38	941
Atk e62	27,0	7,1	0,381	37,7	238	2170	13,98	361	12,91	1052
Seiliger	7,0	7,0	0,269	60,9	226	2204	16,60	467	22,41	1436
Seiliger	15,0	15,0	0,345	49,5	234	2291	6,77	377	7,66	1291

Table 1 Parameter (top) and Performance (bottom)

This table shows the **VER** (volumetric expansion ratio), **VCR** (volumetric compression ratio), μ_{Tx} (turbine discharge coefficient), **n** (engine speed), **AFR** (air-fuel ratio), **SOC** (start of combustion), **CD** (combustion duration), m_{vibe} (exponent of Vibe function for cylinder heat release modeling), **IFCE** (indicated fuel conversion efficiency), **IMEP** (indicated mean pressure), **max(p)** and **max(T)** (maximum pressure and temperature during the cycle), p_{MP8} and T_{MP8} (mean boost pressure and temperature; i.e. at the measuring point MP8, see Fig. 1) and p_{MP12} and T_{MP12} (mean exhaust back pressure and temperature; i.e. at MP12, see Fig. 1) for cylinder 1

The various parameters from Table 1 are selected with the purpose of obtaining roughly the same maximum cylinder pressure **max(p)** (see Table 1) in all cycles. In order to reach this

state, the discharge coefficients of the three turbines are varied according to a) the influence of the backpressure behind the cylinder (e.g., at the measuring point MP12 for cylinder 1; see Fig. 1) and of b) the boost pressure (e.g., at MP8 for cylinder 1). In order to reach approximately the same expansion rate in all three turbines, their discharge coefficients are set at the same level and compensated with the cross sections ratios of the turbine output pipes. Hence, just the discharge coefficient of the third turbine μ_{T3} was adapted for each cycle to meet the cylinder peak pressure limit, since this sets the other two discharge coefficients μ_{T2} and μ_{T1} .

SIMULATION RESULTS AND TRENDS

The following trends arise from the analysis of performance based on the values presented in Table 1:

- All Atkinson cycles show better IFCE values than the Seiliger cycles (see also Fig. 4).
- However, the Seiliger cycles reach higher IMEP values because of the longer intake stroke and thus, of bigger sucked gas mass (see Fig. 9).
- Higher boost pressures p_{MP8} are required in Atkinson as well as in Seiliger cycles in order to hold the parameter **max(p)** steady when VCR is reduced (see Table 1).
- The comparison of the **Atk e62** (with VCR = 7.1) and **Seiliger** (with VCR = 7) cycles shows, that a) the Atkinson cycle has a 40% higher IFCE and reaches 38% less IMEP and b) the Seiliger cycle needs a 19% higher boost pressure (p_{MP8} in Table 1) and has to overcome a 73% higher cylinder backpressure i.e., before **T3** (p_{MP12} in Table 1).
- The comparison of the **Atk e38** (with VCR = 12.7) and **Seiliger** (with VCR = 15) cycles shows, that the Atkinson cycle has a 23% higher IFCE (although the maximum cylinder temperature **max(T)** is 100 K, i.e., 5% lower) and 40% less IMEP.
- The highest IFCE value for Atkinson cycles is not reached in the variant with the highest VCR, but in the variant whose VCR is about 50% of VER. Thus, the optimum variant features an intake stroke equal to approx. 50% of the expansion stroke.

Some diagrams are introduced and analyzed below in order to find out the causes behind these trends. The pressure-volume (**p,v**) diagrams of all cycles and pressure-specific volume (**p,v**) diagrams of the intake and exhaust gas paths (for cylinder 1) are presented in Fig.3 and 4.

One can infer from Table 1 as well as recognize from Fig. 3 and 4 that the Seiliger cycle with VCR = 7 needs the highest boost pressure to reach the desired **max(p)** \approx 230 bar (because of its low VCR). An extremely high back pressure p_{MP12} and the diminishing of ISFC are the consequences because of the required very intensive exhaust work to push out the exhaust gases from cylinder (see green curves up to **ec** points in Fig. 5 and 6). Therefore, this cycle occurs exclusively in the pressure range above 15 bar.

The situation is reversed in the case of the Atkinson cycle **Atk e38** (see for comparison Table 1 and Fig. 4, 7 and 8). This cycle occurs exclusively in the pressure range above 5 bar (see Fig. 3).

The differences between both cycles can be clearly seen in the intake and exhaust gas paths. Fig. 4 and 7 display the three-stage compression of the air and all states after passing through each compressor and intercooler (with associated pressure losses). Fig. 4 and 8 show the three-stage expansion of the exhaust gases in the turbines. In Fig. 8 one can see that the discharge coefficients are properly adapted between the turbines, because the expansion occurs almost linearly in all three stages.

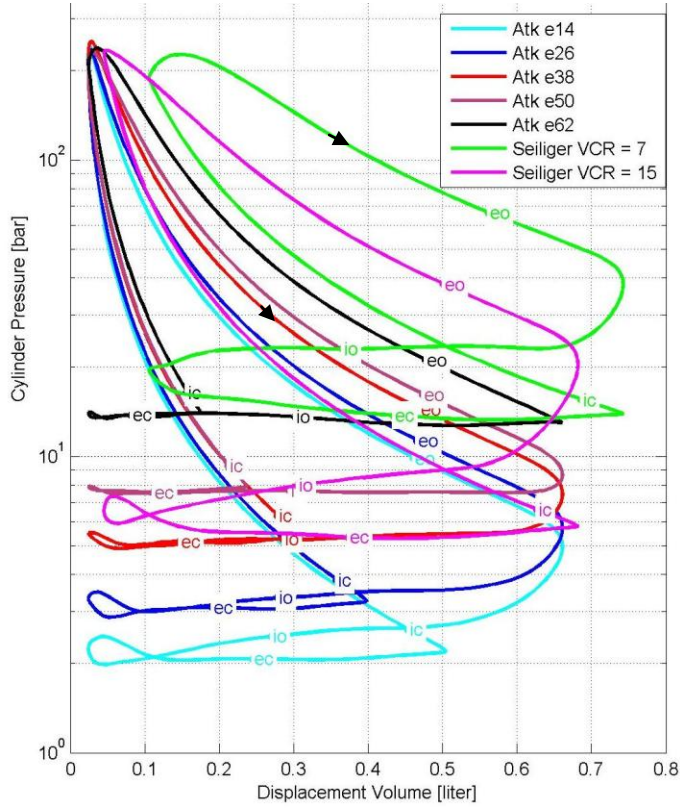

Figure 3 Cylinder Pressure (logarithmic) - Displacement Volume (p,V) Diagrams with Valves Timing for all Cycles Here denote **eo** exhaust open, **ec** exhaust close, **io** intake open, **ic** intake close

The air compression and the exhaust gas expansion for the cycle **Atk e38** occur mostly in **TC3** (see Fig. 4, 7 and 8), because the exhaust gas pressure at the MP18 point (i.e. before **T3**, see Fig. 4 and 8) is too low (see. also Table 1) to be able to drive adequately **T2** and **T1**. Thus, the exhaust gases compress partly in the **T2** and **T1**, instead of expanding (see MP19 to MP21 in Fig. 4). No noticeable improvement of the IFCE is obtained by deleting **TC1** from the BOOST model (i.e., there is no need to remove the unnecessary **TC** in these simulations).

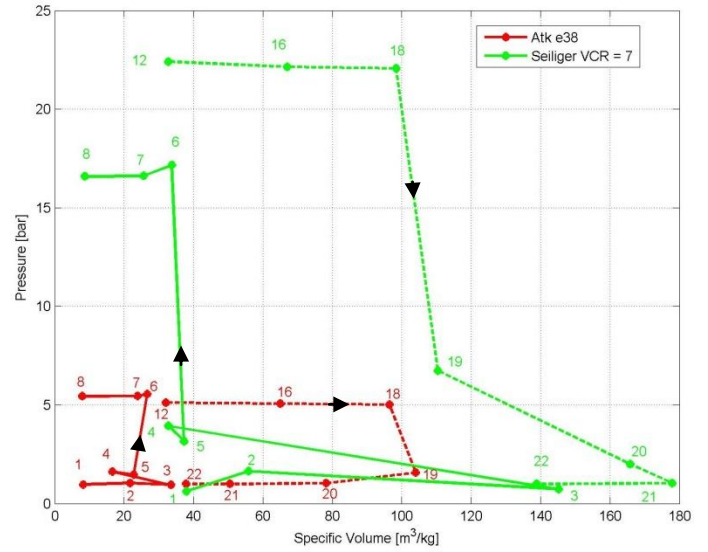

Figure 4 Pressure - Specific Volume (p,v) Diagrams for some MP from the Intake (solid lines) and Exhaust (dashed lines) Pipes for two selected Cycles The numbers denote the states of measuring points from Fig. 1.

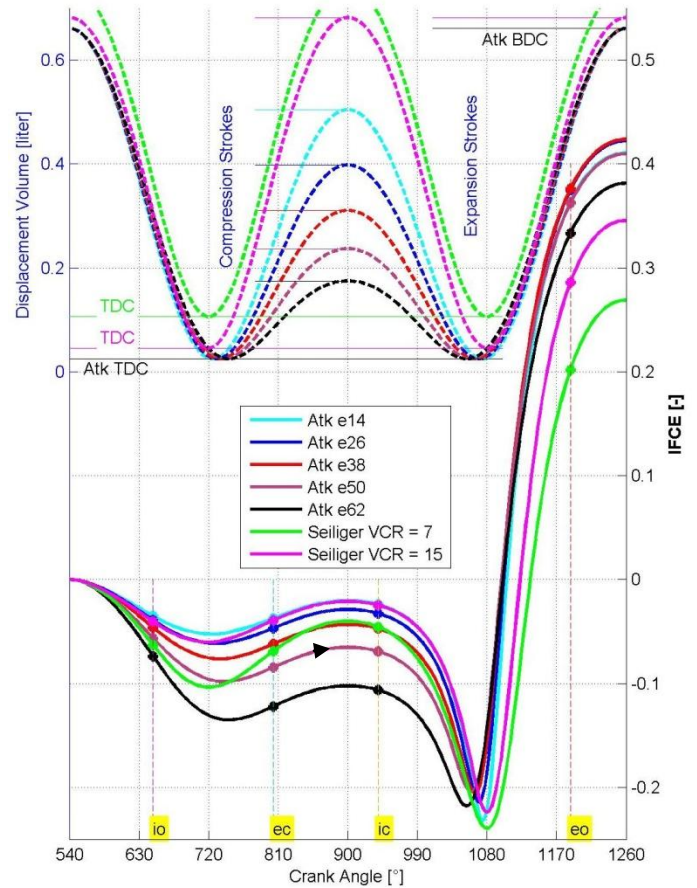

Figure 5 IFCE - Crank Angle ($IFCE,CA$) with Valves Timing (left axis) and Displacement Volume - Crank Angle (V,CA) Diagrams for all Cycles The **TDC** top dead center and **BDC** bottom dead center are shown here

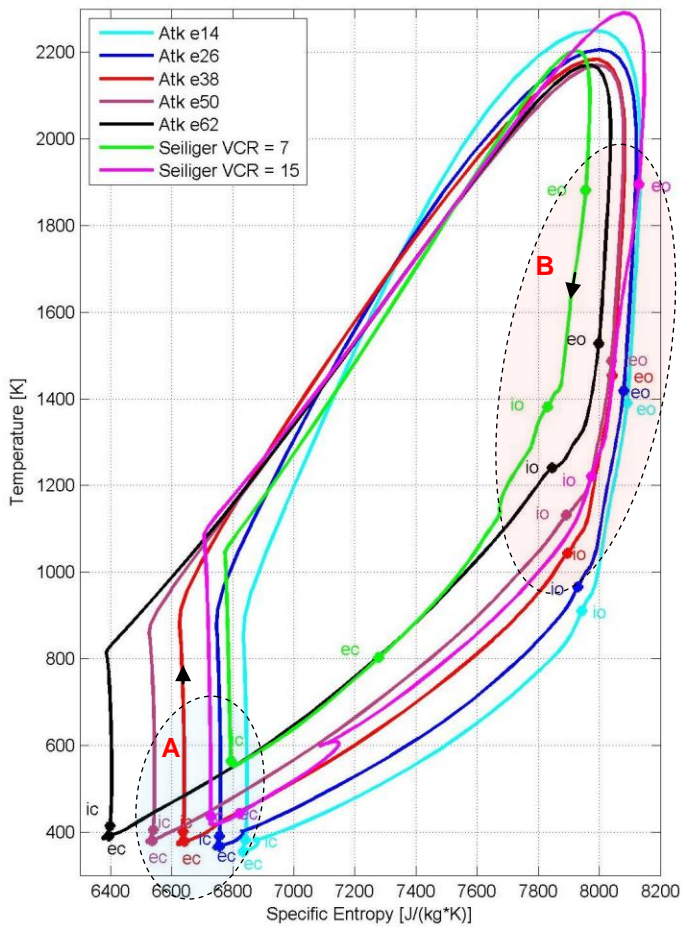

Figure 6 Temperature - Specific Entropy (T,s) Diagrams with Valves Timing for all Cycles
The details **A** and **B** are presented in expanded form in Fig. 7 and 8

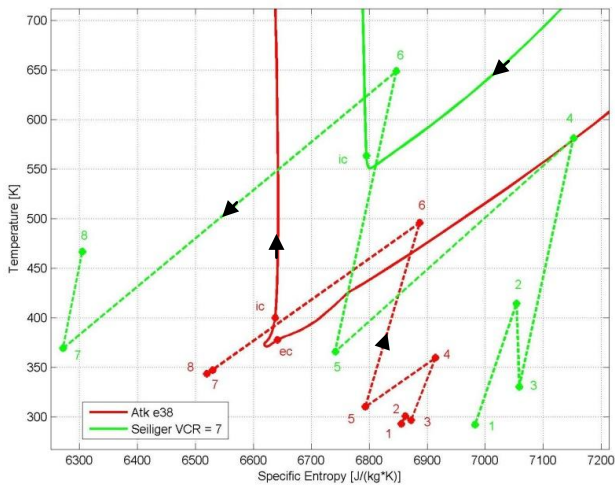

Figure 7 Temperature - Specific Entropy (T,s) Diagrams for some MP (see Fig. 1) from Intake Pipes (dashed lines) superposed on **A** Detail of Fig. 6 (solid lines) for two selected Cycles

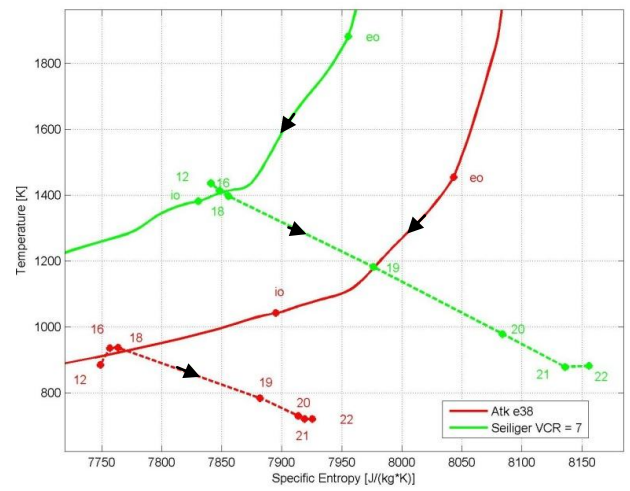

Figure 8 Temperature - Specific Entropy (T,s) Diagrams for some MP (see Fig. 1) from Exhaust Pipes (dashed lines) superposed on **B** Detail of Fig. 6 (solid lines) for two selected Cycles

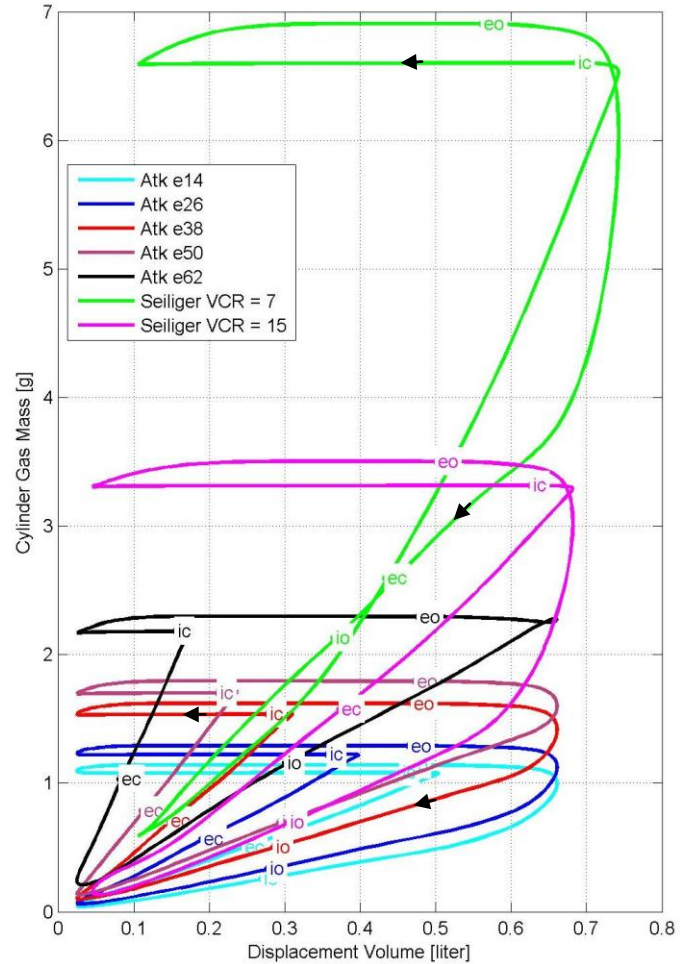

Figure 9 Gas Mass - Displacement Volume (m,V) Diagrams with Valves Timing for all Cycles

CONCLUSION

The implementation of real Atkinson cycles for turbocharged engines using asymmetrical crank mechanisms offers the following advantages: a) relatively high IMEP, b) higher IFCE leading to few CO₂ emissions and c) lower temperatures during the combustion stage leading to few NO_x emissions.

In order to achieve this, the engine requires the use of turbocharger systems with at least two stages, which must be adapted accordingly and controlled with the help of bypasses to maximize their performance.

The optimum ratio between the internal (i.e. within cylinder) and external (i.e. within turbines) expansion of the exhaust gases which maximize IFCE is reached when the VCR is close to 50% of VER.

REFERENCES

- [1] R. Weinowski, A. Sehr, S. Wedowski, S. Heuer, T. Hamm, C. Tiemann, *Future downsizing of S.I. engines - potentials and limits of 2- and 3-cylinder concepts*, Vienna Motor Symposium 2009
- [2] V. Korte, G. Lumsden, N. Fraser, J. Hall, *30% higher efficiency at 50% less displacement*, MTZ 2010
- [3] V. Gheorghiu, *CO₂ emission reduction by means of enhancement of the thermal conversion efficiency of ICE cycles*, HEFAT 2010
- [4] Schutting, E, Neureiter, A, Fuchs, Ch., Schwarzenberger, T, Klell, M, Eichlseder, H, Kammerdiener, T, *Miller- and Atkinson-Cycle for Supercharged Diesel Engines*, MTZ 06 / 2007 (German)