

# Generalised beta type II distributions - emanating from a sequential process

by

Karien Adamski

Submitted in partial fulfilment of  
the requirements for the degree

Philosophiae Doctor (Mathematical Statistics)

In the Faculty of Natural & Agricultural Sciences  
University of Pretoria  
Pretoria

November 2013

# Declaration

I, Karien Adamski, declare that the thesis, which I hereby submit for the degree Philosophiae Doctor (Mathematical Statistics) at the University of Pretoria, is my own work and has not previously been submitted by me for a degree at this or any other tertiary institution.

SIGNATURE:.....

DATE:.....

# Acknowledgements

I wish to express my appreciation to the following persons who made this thesis possible:

- My supervisor and mentor, Prof. Andriëtte Bekker, for her guidance, support and motivation. She is a dedicated researcher that connects with her students on a personal level and that makes it an enjoyable experience.
- My co-supervisors, Prof. J.J.J. Roux and Dr. Schalk Human, for their valuable input. Prof. Roux, providing the sound ability to place all the ideas related to this study in a proper distribution theory context; and Dr. Human, a heartfelt thanks for his help regarding the practical aspect of this study and the writing-up thereof.
- My family for their support and understanding during the time it took to complete this thesis. Specifically:
  - My husband, Zbigi. There are no words to describe how much I appreciate all the sacrifices he has made during this time.
  - My son, Eddie, for the sacrifices he made even though he was unaware of it.
  - My mother, Katrien Malan, for encouraging me to go to university and the opportunity to study.
  - My grandmother, for all her words of encouragement.
  - My parents in law, Grazka and Stefan Adamski, for their help with Eddie especially during these last few months when I was busy with the write-up.

Lastly, I would like to acknowledge the financial assistance I received:

- UP Vice-Chancellor's academic development grant;
- Thuthuka program of the National Research Foundation (NRF);
- Department of Statistics, University of Pretoria and STATOMET.

To Zbigi, for your love, support and sacrifices.

# Summary

This study focuses on the development of a generalised multivariate beta type II distribution as well as the noncentral and bimatrix counterparts with positive domain. These models emanate from a sequential quality monitoring procedure with the normal and multivariate normal distributions as the underlying process distributions. Three different scenarios are considered, namely:

1. The variance is monitored from a normal process and the mean remains unchanged;
2. The above-mentioned scenario but the known mean also encounters a sustained shift;
3. The covariance structure of a multivariate normal distribution is monitored with the known mean vector unchanged.

The statistics originating from the above-mentioned scenarios considered are constructed from different dependent chi-squared or Wishart ratios. Exact expressions are derived for the probability density functions of these statistics. These new distributions contribute to the statistical discipline in the sense that it can serve as alternatives to existing probability models, and can be used in determining the performance of the quality monitoring procedure.

# Research outputs

A list of research outputs related to this thesis is given below:

## Articles:

Adamski, K., Human, S.W., Bekker, A. and Roux, J.J.J. (2013). Noncentral generalized multivariate beta type II distribution, *REVSTAT - Statistical Journal*, 11(1), 1-27.

Adamski, K., Human, S.W. and Bekker, A. (2012). A generalized multivariate beta distribution: control charting when the measurements are from an exponential distribution, *Statistical Papers*, 53, 1045-1064.

Bekker, A., Adamski, K., Roux, J.J.J. and Human, S.W. (2013). Extended bimatrix variate beta type II distribution - emanating from a sequential process, submitted to *Linear Algebra and its Applications*.

## Conference presentations:

Bekker, A., Roux, J.J.J., Adamski, K. & Human, S.W. (2012). The description of the extended bimatrix variate beta type II distribution. Annual conference of the South African Statistical Association (Nelson Mandela Metropolitan University, Port Elizabeth).

Human, S.W., Adamski, K., Bekker, A. & Roux, J.J.J. (2012). Origin and application of a noncentral generalized multivariate beta type II distribution. Annual conference of the South African Statistical Association (Nelson Mandela Metropolitan University, Port Elizabeth).

Adamski, K., Human, S.W., Bekker, A. & Roux, J.J.J. (2012). Invited lecture: Noncentral generalized multivariate beta type II distribution. Joint Meeting of y-BIS and jSPE, Lisbon, Portugal, 23-25 July.

Bekker, A., Roux, J.J.J., Adamski, K. & Human, S.W. (2012). Extended bimatrix beta type II distribution. 8th World Congress in Probability and Statistics, Istanbul, Turkey, 9-14 July.

Adamski, K., Human, S.W. & Bekker, A. (2011). The theoretical development of a new multivariate beta distribution. 58th Session of the International Statistical Institute (ISI), Dublin, Ireland, 21-26 August.

Adamski, K., Human, S.W. & Bekker, A. (2010). A Generalized Multivariate Beta Distribution: control charting when the measurements are from an exponential distribution. Annual conference of the South African Statistical Association (North-West University, Potchefstroom).

# Contents

|   |      |
|---|------|
| CONTENTS  | viii |
| 1 INTRODUCTION  | 1    |
| 1.1 Background . . . . .  | 1    |
| 1.2 Example . . . . .   | 3    |
| 1.3 Objectives and scope . . . . .  | 7    |
| 2 GENERALISED MULTIVARIATE BETA TYPE II DISTRIBUTIONS                           | 10   |
| 2.1 Introduction . . . . .  | 10   |
| 2.2 Problem statement . . . . .   | 11   |
| 2.3 The generalised multivariate beta type II distribution . . . . .            | 16   |
| 2.4 Marginal generalised beta type II distributions . . . . .                   | 26   |
| 2.4.1 Generalised univariate beta type II distribution . . . . .                | 27   |
| 2.4.2 Generalised bivariate beta type II distribution . . . . .                 | 32   |
| 2.4.3 Distribution of a subset . . . . .  | 36   |
| 2.5 Product moments of the random variables . . . . .                           | 38   |
| 2.6 Shape analysis and correlation . . . . .                                    | 43   |
| 2.7 Conclusion . . . . .  | 49   |
| 3 NONCENTRAL GENERALISED MULTIVARIATE BETA TYPE II DISTRIBUTIONS                | 50   |
| 3.1 Introduction . . . . .  | 50   |
| 3.2 Problem statement . . . . .   | 53   |
| 3.3 The noncentral generalised trivariate beta type II distribution . . . . .   | 61   |
| 3.3.1 The probability density function . . . . .                                | 61   |
| 3.3.2 Marginal noncentral generalised beta type II distributions . . . . .      | 66   |
| 3.4 The noncentral generalised multivariate beta type II distribution . . . . . | 77   |
| 3.5 Shape analysis . . . . .  | 81   |
| 3.6 Conclusion . . . . .  | 84   |



|              |  |     |
|--------------|--|-----|
| 4            | GENERALISED BIMATRIX VARIATE BETA TYPE II DISTRIBUTIONS  | 85  |
| 4.1          | Introduction . . . . .   | 85  |
| 4.2          | Problem statement . . . . .  | 85  |
| 4.3          | The generalised bimatrix variate beta type II distributions . . . . .                                  | 89  |
| 4.3.1        | The covariance structure change from $\Sigma$ to $\lambda\Sigma$ . . . . .                             | 89  |
| 4.3.1.1      | The probability density function . . . . .   | 90  |
| 4.3.1.2      | Marginal probability density functions . . . . .   | 93  |
| 4.3.1.3      | Product moment of the determinants . . . . .   | 99  |
| 4.3.1.4      | Distributions of $ \mathbf{U}_0 $ , $ \mathbf{U}_1 $ and $ \mathbf{U}_0\mathbf{U}_1 $ . . . . .        | 103 |
| 4.3.2        | The covariance structure change from $\Sigma$ to $\Sigma_1$ . . . . .                                  | 112 |
| 4.3.2.1      | The probability density function . . . . .   | 112 |
| 4.3.2.2      | Marginal probability density function . . . . .  | 117 |
| 4.3.2.3      | Product moment of the determinants . . . . .   | 126 |
| 4.3.2.4      | Distributions of $ \mathbf{U}_0 $ , $ \mathbf{U}_1 $ and $ \mathbf{U}_0\mathbf{U}_1 $ . . . . .        | 130 |
| 4.3.2.5      | Distribution of $( \mathbf{U}_0 ,  \mathbf{U}_1 )$ . . . . .   | 139 |
| 4.4          | Conclusion . . . . .   | 141 |
| 5            | ILLUSTRATIVE EXAMPLES  | 143 |
| 5.1          | Run-length probabilities if the unknown process variance has changed . . . . .                         | 143 |
| 5.1.1        | The generalised distribution approach . . . . .  | 145 |
| 5.1.2        | The simulation approach . . . . .  | 149 |
| 5.1.3        | Assuming independence . . . . .  | 150 |
| 5.1.4        | A conditioning approach . . . . .  | 152 |
| 5.2          | Run-length probabilities if the unknown process variance and known process mean have changed . . . . . | 158 |
| 5.3          | Run-length probabilities in the matrix environment . . . . .   | 159 |
| 5.4          | Conclusion . . . . .   | 162 |
| 6            | CONCLUSIONS  | 163 |
| APPENDICES   |  |     |
| A.           | Abbreviations and notation . . . . .   | 167 |
| B.           | Scalar special functions and theory . . . . .  | 169 |
| C.           | Matrix special functions and theory . . . . .  | 174 |
| BIBLIOGRAPHY |  |     |
|              |  | 184 |

# Chapter 1

## Introduction

### 1.1 Background

This thesis introduces the generalised multivariate beta type II distribution as well as the noncentral and matrix variate counterparts. The research emanates from a practical problem in the process or quality control environment where a control chart is used to monitor the quality of a process over time. In this chapter some background of the quality monitoring procedure is given to set the platform of this study. It is important to note that the author does not intend to present a complete discussion of the aspects of Statistical Process Control (SPC). Instead, only the key aspects will be considered to equip the reader with the necessary terminology in order to grasp the content covered in this thesis.

A control chart is a statistical procedure that can be depicted graphically that is used to monitor an attribute (such as the mean or variance) of a process with the objective to determine whether the process is stable or in-control. The simplest and most widely used control chart is the Shewhart-type of chart; this chart is named after the father of quality control Dr. Walter A. Shewhart (1891-1967). A typical Shewhart-type control chart is shown in Figure 1.1. The chart is a basic graphical display of the successive values of a summary measure (charting statistic) calculated from a sample of measurements taken on a key quality characteristic and plotted on the vertical axis versus the sample number or time on the horizontal axis. The control chart usually has a centerline ( $CL$ ) and two horizontal lines, one line on either side of the centerline. The line above the centerline is called the upper control limit ( $UCL$ ) whereas the line below the centerline is called the lower control limit ( $LCL$ ). These three lines are placed on the control chart to aid the user in making an informed and objective decision whether a process is in-control or not; this decision is primarily based on the pattern of the points plotted on the chart and/or

their position relative to the control limits. Notice that it is customary to join the points on a control chart using straight-line segments for easier visualisation over time.

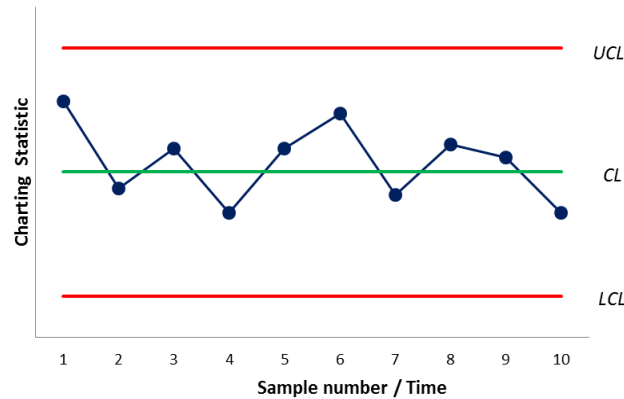

**Figure 1.1.** A Shewhart-type control chart

The Shewhart-type control charts are typically based on (i) taking successive samples from the output of the process, (ii) calculating the specified sample statistic from each sample, and (iii) comparing the value of each sample statistic (i.e. the charting statistic), one after the other, with the control limits. An alarm (a signal) is issued if a single point (charting statistic) plots on or outside the control limits i.e. lies on or above the upper control limit or lies on or below the lower control limit. The alarm signals that the process is deemed to be in an out-of-control state and a search for assignable causes typically follows. A desirable property of a chart is to signal quickly when a change takes place and not signal too often when the process is actually in-control (which is when no shift or change has taken place). Hence the performance of the chart i.e. how efficient the chart is in detecting changes, is of importance. To gain insight into the performance of a control chart, the run-length distribution is considered. Once a shift in the process parameter occurred, the run-length is defined as the number of samples collected until the shift is detected (i.e. an out-of-control signal is observed). For a detailed discussion see Montgomery (2009) [31].

In this thesis the attribute of interest is the variance or covariance structure of a process. In practice, process variability is often monitored by plotting the sample range (R chart) or sample standard deviation (S chart) on a Shewhart control chart. Alternatively the cumulative sum (CUSUM) or the exponentially weighted moving average (EWMA) charts could be used. The CUSUM and EWMA control charts are different from the Shewhart-type chart in that they are memory-based charts which sequentially combine the information from multiple (past) samples with the present (or current) sample information in the decision making process. The Shewhart-type of chart, however, uses only the information available from the most recent (last) sample. For all of these control charts calibration

samples are needed to first estimate the parameters (used for setting up the control limits) before real-time charting begins.

Classical control charts such as the Shewhart, CUSUM and the EWMA are designed for processes where either the process parameters are known, or sufficient historical data is available to estimate any unknown parameters (see e.g. Montgomery, 2009 [31]). Quesenberry (1991) [41], however addressed the problem of monitoring an attribute from the start of production, whether or not prior information is available and proposed the so-called Q-charts. These Q-charts are constructed by calculating a sample statistic and then transforming this statistic to obtain the charting statistic that is plotted on a Shewhart-type control chart.

The practical problem that initiated the research and that is covered in this thesis is monitoring the process variance, when the measurements are taken from a normal distribution, using a Q-chart; this was then extended to also focus on monitoring the covariance structure of a multivariate normal distribution. An example is given in the next section to explain how a Q-chart operates.

## 1.2 Example

In this example a Q-chart is used to monitor the unknown process variance, assuming that the observations from each independent sample are independent identically distributed (i.i.d.) normal random variables with the mean known. The purpose of this example is to give an overview of the procedure to set up the control chart; for more detail see Quesenberry (1991) [41].

To describe the construction of a Q-chart suppose that twenty samples each of size four were generated. The first ten samples were generated from a normal distribution with mean ten and variance equal to one, denoted by  $N(10, 1)$ . Between samples ten and eleven it is assumed that the process variance encountered a sustained shift and therefore the last ten samples were generated from a  $N(10, 2)$  distribution. The simulated data set is given in Table 1.1 and the control chart in Figure 1.2. Let  $(Y_{i1}, Y_{i2}, \dots, Y_{in_i})$ ,  $i = 1, 2, \dots, 20$  represent successive, independent samples of size  $n_i \geq 1$  measurements made on a sequence of items produced in time. Note that in this example  $n_i = 4$ . The charting statistic is obtained using the following steps:

1. Calculate the sample variance for each sample i.e.  $S_i^2 = \frac{1}{n_i} \sum_{k=1}^{n_i} (Y_{ik} - \mu_0)^2$  for  $i = 1, 2, \dots, 20$  where  $\mu_0 = 10$ .

The sample variance is used since it is an unbiased estimator of the variance.

## 1. INTRODUCTION

## 1.2. Example

2. Calculate the two sample test statistic, for testing the null hypothesis at time  $i$  that the two independent samples are from a normal distribution with the same unknown variance,  $\frac{S_i^2}{S_{i-1}^{2pooled}}$  where  $S_{i-1}^{2pooled} = \frac{\sum_{i=1}^{i-1} n_i S_i^2}{\sum_{i=1}^{i-1} n_i}$ . Thus, the variance of the  $i^{th}$  sample is divided by the pooled variance of the first  $i - 1$  samples combined, for  $i = 2, 3, \dots, 20$ .

3. Calculate the charting statistic,  $Q_i = \Phi^{-1} \left[ F_{n_i, n_1+n_2+\dots+n_{i-1}} \left( \frac{S_i^2}{S_{i-1}^{2pooled}} \right) \right]$  for  $i = 2, 3, \dots, 20$  where  $F_{n_i, n_1+n_2+\dots+n_{i-1}}(\cdot)$  denotes the cumulative distribution function of the  $F$  distribution. The two sample test statistic given in step 2 has an  $F$  distribution under the null hypothesis (see Remark 2.1 in Chapter 2).  $\Phi^{-1}(\cdot)$  denotes the inverse of the standard normal cumulative distribution function. The charting statistic is a standard normal random variable obtained by transforming the two sample test statistic using the classical probability integral transformation theorem.

**Remark 1.1** *The classical probability integral transformation theorem states: for a random variable  $Y$  with continuous distribution function  $G$ , the transformed random variable  $G(Y)$  has a uniform distribution on the unit interval  $(0, 1)$ ; and conversely, if  $V$  is a uniform random variable on the unit interval, then  $G^{-1}(V)$  has the distribution of  $Y$  (see Bain and Engelhardt, 1992 [3], p.201).*

4. Plot the charting statistic on a Shewhart-type chart with the typical three sigma control limits where sigma refers to the standard deviation of the statistic ( $Q_i$ ) plotted on the chart. Take note that the Q-chart is plotted in a standardised normal scale therefore the  $LCL$  and  $UCL$  are equal to  $\pm 3$  and the centerline  $CL$  is 0 (see Montgomery, 2009 [31], p.184).

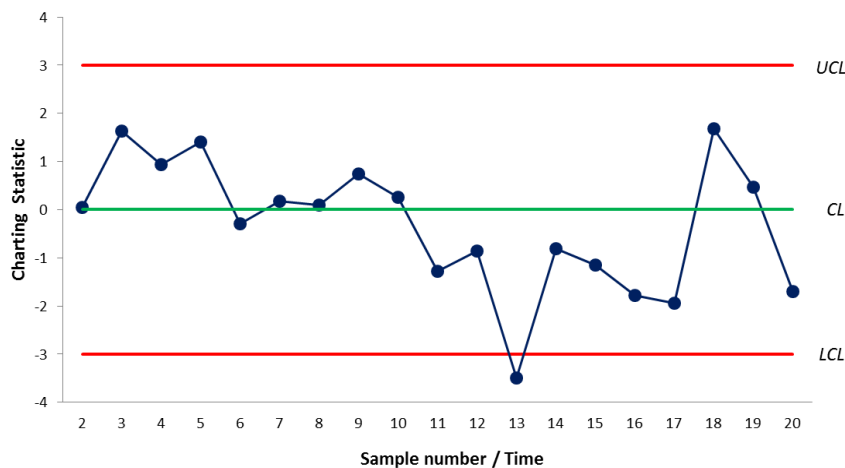

Figure 1.2. Q-chart for the example

**Table 1.1.** Simulated data set

| Sample         | $Y_{i1}$ | $Y_{i2}$ | $Y_{i3}$ | $Y_{i4}$ | $S_i^2$ | $\frac{S_i^2}{S_{i-1}^{2\text{pooled}}}$ | $Q_i$  |
|----------------|----------|----------|----------|----------|---------|--|--------|
| 1              | 8.4      | 9.1      | 10.6     | 8.9      | 1.235   | NA*                                      | NA     |
| 2              | 9.6      | 8.8      | 8.8      | 11.3     | 1.183   | 0.957                                    | 0.041  |
| 3 <sup>†</sup> | 10.1     | 9.9      | 9.6      | 10.8     | 0.205   | 0.170                                    | 1.625  |
| 4              | 10.3     | 10.6     | 10.6     | 10.7     | 0.325   | 0.372                                    | 0.932  |
| 5              | 10.7     | 10.0     | 9.6      | 10.1     | 0.165   | 0.224                                    | 1.412  |
| 6              | 8.6      | 9.6      | 9.4      | 10.5     | 0.683   | 1.096                                    | -0.291 |
| 7              | 9.0      | 9.1      | 10.3     | 10.0     | 0.475   | 0.751                                    | 0.169  |
| 8              | 10.0     | 10.9     | 10.7     | 9.2      | 0.485   | 0.795                                    | 0.096  |
| 9              | 9.1      | 10.0     | 9.5      | 10.1     | 0.268   | 0.450                                    | 0.744  |
| 10             | 10.1     | 11.2     | 10.0     | 9.7      | 0.385   | 0.690                                    | 0.263  |
| 11             | 11.3     | 9.6      | 11.2     | 11.1     | 1.125   | 2.080                                    | -1.273 |
| 12             | 10.1     | 11.0     | 11.5     | 9.3      | 0.938   | 1.579                                    | -0.853 |
| 13             | 9.0      | 7.2      | 11.7     | 7.8      | 4.143   | 6.655                                    | -3.491 |
| 14             | 9.3      | 7.8      | 9.7      | 9.8      | 1.365   | 1.528                                    | -0.815 |
| 15             | 9.7      | 11.9     | 10.2     | 8.2      | 1.745   | 1.882                                    | -1.144 |
| 16             | 9.5      | 9.0      | 9.0      | 12.9     | 2.665   | 2.715                                    | -1.774 |
| 17             | 7.8      | 11.6     | 9.5      | 7.7      | 3.235   | 2.977                                    | -1.950 |
| 18             | 10.5     | 9.6      | 9.6      | 10.5     | 0.205   | 0.169                                    | 1.680  |
| 19             | 10.9     | 9.5      | 11.2     | 9.6      | 0.665   | 0.575                                    | 0.473  |
| 20             | 11.1     | 13.2     | 9.8      | 10.3     | 2.895   | 2.559                                    | -1.693 |

<sup>†</sup> The  $Q_i$  for sample 3 is computed as follows:  $S_3^2 = \frac{1}{4} \sum_{k=1}^4 (Y_{3k} - 10)^2 = 0.205$   
 $\frac{S_3^2}{S_2^{2\text{pooled}}} = \frac{0.205}{\frac{4 \times 1.235 + 4 \times 1.183}{8}} = 0.170$   
 $Q_i = \Phi^{-1} [F_{4,8} (0.170)] = 1.625$

There is no charting statistic that corresponds to sample number one as this sample is used to obtain an initial estimate of the process variance. Take note that in practice the variance is unknown and that it was only assumed for illustration purposes in this example that the variance changed from one to two. The process is effectively monitored from sample two onwards. For this example, the process is declared out-of-control at sample number thirteen since this is the first sample where a charting statistic plots on or outside the control limits (see Figure 1.2). Note that, in this example the variance changed between samples ten and eleven. Three samples were collected after the change

---

\* Not Applicable

in the variance before the control chart signalled that the process is out-of-control by plotting outside the lower control limit, therefore the run-length is three. Once the process variance encountered a sustained shift, some questions arise, for example:

- What is the probability that a charting statistic will plot inside or outside the control limits?
- What is the probability that the chart will signal immediately? In other words, what is the probability that the run-length is equal to one?
- In general, what is the probability that the run-length is equal to  $k$  for  $k = 1, 2, \dots$ ?

A broad outline of this example is summarised in Figure 1.3. Independent samples of observations are taken from a normal distribution; the latter is referred to as the process distribution. A sample statistic, namely the sample variance ( $S_i^2$ ), is calculated for each incoming sample. The charting statistic ( $Q_i$ ) is a function of the sample variances. The distribution of the charting statistics as well as the joint distribution thereof, after the change in the process parameter, will be derived in this thesis. Finally, the joint distribution of the charting statistics can be used to determine run-length probabilities.

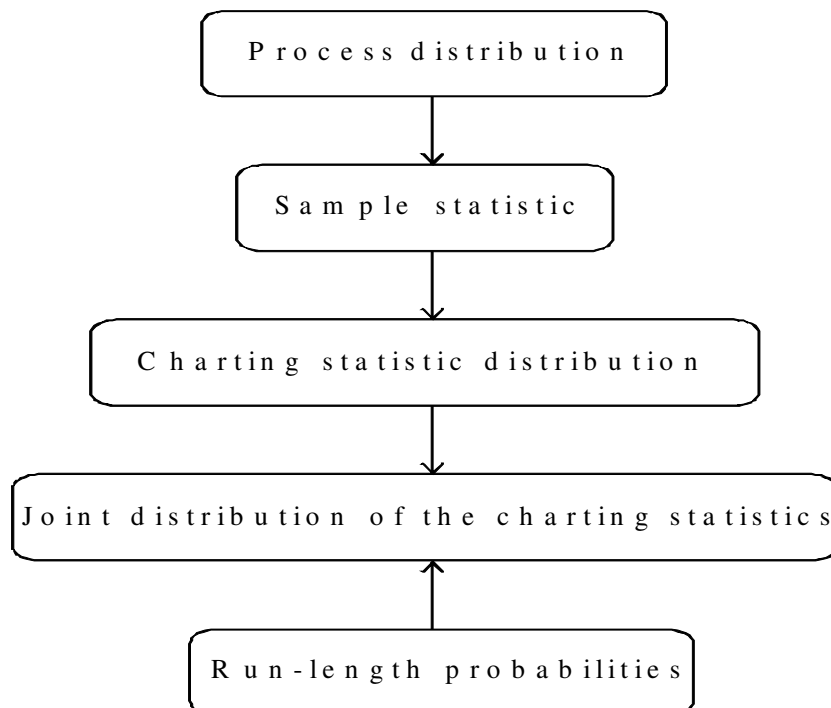

**Figure 1.3.** Broad outline of the example

Starting from the questions raised above originating from the sequential quality monitoring procedure, it will be endeavoured in this study to contribute to the distribution theory field. Distribution theory lies at the intersection of probability and statistics and is the foundation from which all statistical theory and application originates. Enhancing our knowledge of distribution theory therefore implies that the general body of knowledge of statistics is improved. The objectives and scope of this study will be highlighted in the next section.

### 1.3 Objectives and scope

- Present the problem statements within the SPC environment from which new distributions emanated.
- Follow a systematic approach in building-up the distributions, starting in each case from successive, independent samples of measurements that are made on a sequence of items produced in time with the assumption that the process distribution is a normal distribution or a multivariate normal distribution.
- Specifically focus on the development of these new distribution models.
- Investigate the role of the closed form expressions of the distribution models in the SPC environment with specific focus on calculating the run-length probabilities.

The example in Section 1.2 portrayed the situation when independent samples are taken from a normal distribution and the variance of the sequential process is monitored and it encounters an unknown sustained shift. Only a permanent upward or downward step shift in the variance is considered; other types of shifts falls outside the scope of this thesis. The run-length is a measure to gain insight into the performance of a control chart. To develop exact expressions for the probabilities of run-lengths, the joint distribution of the charting statistics is needed. This will be discussed in Chapter 2 as well as Chapter 5. This thesis introduces closed form expressions for the joint distribution of charting statistics.

The sequential procedure to monitor the variance is an on-going process; therefore theoretically the charting statistics could be calculated for all time periods as it tends to infinity. In this thesis the charting statistics from immediately after the shift in the variance up to  $p$  samples afterwards will be considered. The properties of the new distribution models as  $p$  tends to infinity fall outside the scope of this thesis.



The emphasis of this study, as can be seen from Figure 1.4, is a systematic approach in building up new generalised multivariate beta type II distribution models from a sequential process. In Chapter 2 the generalised multivariate beta type II distribution is derived; this distribution stems from monitoring the variance of a normal random variable where the mean remains unchanged. The statistical property that will be focused on in this chapter is the moments to shed light on the nature of this distribution. The property is of importance because once the process is out-of-control the charting statistics are no longer independent and in order to investigate this, the correlation structure is of particular interest.

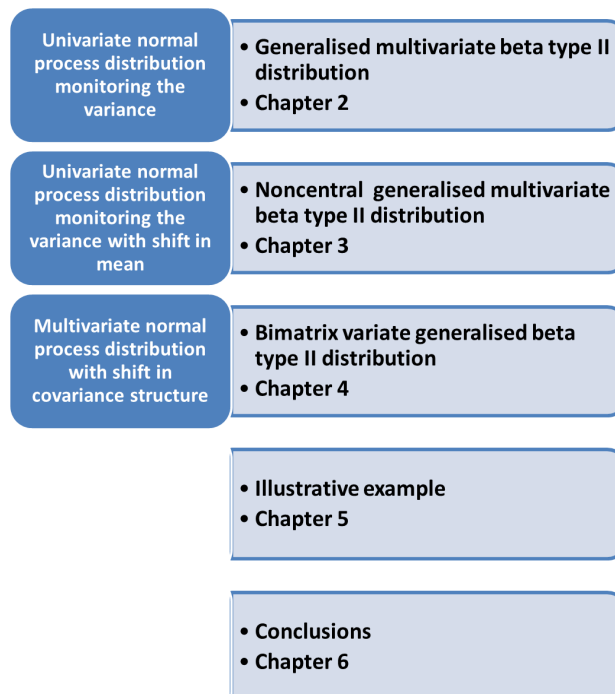

**Figure 1.4.** Thesis outline

The focus of Chapter 3 is on the scenario where the variance of a normal random variable is monitored but the mean also encounters a sustained shift. This introduces the non-central generalised multivariate beta type II distribution. Since the correlation will be investigated in Chapter 2, only the effect of the noncentrality parameter will be demonstrated.

In Chapter 4 the generalised bimatrix variate beta type II distribution is proposed. Two cases will be considered here, namely the special case where the covariance structure changes with a scale factor, and secondly the more general case with a complete change in

the covariance structure. The product moments will be derived to determine the distributions of the determinants of the statistics needed to calculate the run-length probabilities in Chapter 5.

To the author's knowledge, the newly derived exact expressions of the generalised multivariate beta type II distribution models are used for the first time in an illustrative example to calculate probabilities needed for charting statistics, instead of the existing methods within the SPC environment (e.g. simulation). A measure is also presented in Chapter 5 if measurements are made where the samples are independent having been collected from a multivariate normal distribution.

Chapter 6 gives some conclusive remarks and further developments. The Appendix, towards the end of this study, is a collection of some fundamental mathematical results used in this study.

## Chapter 2

# Generalised multivariate beta type II distributions

### 2.1 Introduction

In this chapter the generalised multivariate beta type II distribution is derived; this distribution stems from monitoring the variance of a normal random variable by taking successive, independent samples of measurements over time. These measurements are independent and identically distributed collected from a  $N(\mu_0, \sigma^2)$  distribution. The mean ( $\mu_0$ ) is known and the unknown variance change from  $\sigma^2$  to  $\sigma_1^2 = \lambda\sigma^2$  (also unknown) where  $\lambda \neq 1$  and  $\lambda > 0$  somewhere between samples  $\kappa - 1$  and  $\kappa$ . Therefore, from sample  $\kappa$  onwards the process is considered out-of-control. This scenario is depicted in Figure 2.1.

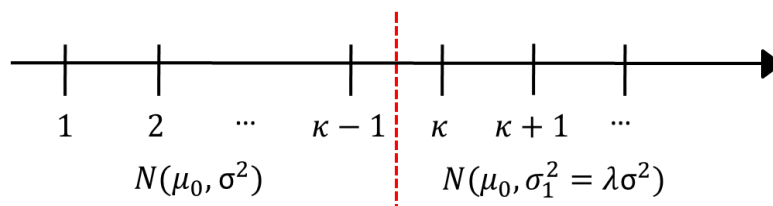

**Figure 2.1** Monitor the variance when the known mean remains unchanged

Section 2.2 gives an overview of the process monitoring problem that leads to the random variables of interest. The joint distribution of these random variables gives rise to a new distribution that can be regarded as a generalised multivariate beta type II distribution. Sections 2.3 and 2.4 focus on the joint and marginal distributions, respectively. Since the moments are needed to investigate the correlation structure between the random variables, this is the only statistical property of the distribution that is focused on in Section 2.5. A shape analysis of the univariate and bivariate distributions as well as the correlation of the charting statistics for the bivariate case is considered in Section 2.6. An example of

## 2. GENERALISED MULTIVARIATE BETA TYPE II DISTRIBUTIONS

### 2.2. Problem statement

using the generalised multivariate beta type II distribution to calculate some run-length probabilities is deferred to Chapter 5.

## 2.2 Problem statement

The example in Section 1.2 illustrated the use of a Q-chart and it highlighted the importance of the joint distribution of the charting statistics once a shift in the process parameter occurred. In this section the random variables of interest are derived when monitoring the variance of normal random variables using a Q-chart.

Let  $(Y_{i1}, Y_{i2}, \dots, Y_{in_i}), i = 1, 2, \dots$  represent successive, independent samples of size  $n_i \geq 1$  measurements made on a sequence of items produced in time. Assume that these values are independent and identically distributed having been collected from a  $N(\mu_0, \sigma^2)$  distribution where the parameters  $\mu_0$  and  $\sigma^2$  denotes the known process mean and unknown process variance, respectively. Suppose that the unknown process variance has encountered a permanent upward or downward step shift between samples (time periods)  $\kappa - 1$  and  $\kappa$  with  $\kappa > 1$  from  $\sigma^2$  to  $\sigma_1^2 = \lambda\sigma^2$  (also unknown) where  $\lambda \neq 1$  and  $\lambda > 0$ . In practice  $\kappa$  and  $\lambda$  would be unknown (but deterministic) values. Take note that other types of shifts, for example a trend or cycle, falls outside the scope of this thesis.

Since the process variance  $\sigma^2$  is unknown, the first sample is used to obtain an initial estimate of  $\sigma^2$ . It is assumed that the process starts in-control. This is an important assumption because the data is used to compute estimates of the unknown process parameter which will in turn be incorporated in the charting statistic that is used to determine if the process is in-control. This initial estimate is continuously updated using the new incoming samples as they are being collected, as long as the estimated value of  $\sigma^2$  does not change, i.e. is not detected using the control chart. To this end, let

$$S_r^{2_{pooled}} = \frac{\sum_{i=1}^r n_i S_i^2}{\sum_{i=1}^r n_i} \text{ for } r = 1, 2, \dots \quad (2.1)$$

where  $S_i^2 = \frac{1}{n_i} \sum_{k=1}^{n_i} (Y_{ik} - \mu_0)^2$  for sample  $i = 1, 2, \dots$ ,

where  $S_r^{2_{pooled}}$  denotes the pooled sample variance of all the measurements up to and including sample  $r$ ; and  $S_i^2$  denote the variance of the  $i^{th}$  sample with  $\mu_0$  representing the known population mean. According to (2.1),  $i$  denotes time and  $r$  is a specific point in time. Take note that a sample can even consist of an individual observation because the process mean is assumed to be known and the variance of the sample can still be calculated as  $S_i^2 = (Y_{i1} - \mu_0)^2$  for  $i = 1, 2, \dots$ . The sequential sample quantity in (2.1) is computed

## 2. GENERALISED MULTIVARIATE BETA TYPE II DISTRIBUTIONS

### 2.2. Problem statement

as each new sample becomes available. Therefore, the variance of the first sample, i.e.  $S_1^2$ , estimates  $\sigma^2$  at sample one. At sample two  $S_2^2$  is compared to  $S_1^2$  to determine whether the value of  $\sigma^2$  is still the same. If the hypothesis of equal variances cannot be rejected, i.e. the charting statistic plotted inside the control limits, a new updated estimate of  $\sigma^2$  is obtained. The updated estimate is  $S_2^{2pooled}$  and includes information from samples one and two; this point estimate is then used to check if the value of  $\sigma^2$  is still the same at sample three by comparing  $S_3^2$  to  $S_2^{2pooled}$ . This sequential updating-and-testing procedure continues until a change is detected in the value of  $\sigma^2$ . A change in the variance will be detected when a charting statistic plots on or outside the control limits.

The control chart and the charting statistic are based on the in-control distribution of the process, in other words they are derived under the null hypothesis of no change in the process variance. The two sample test statistic for testing the hypothesis at time  $i = r$  that the two independent samples (the measurements of the  $r^{th}$  sample alone and the measurements of the first  $r - 1$  samples combined) are from normal distributions with the same unknown variance  $\sigma^2$  (see Bain and Engelhardt, 1992 [3], p.402), is based on the statistic

$$U_r^* = \frac{S_r^2}{S_{r-1}^{2pooled}} \text{ for } r = 2, 3, \dots, \quad (2.2)$$

where  $S_r^2$  and  $S_{r-1}^{2pooled}$  are defined in (2.1).

#### Remark 2.1

- (i) *The statistic (2.2) can be determined from  $r = 2$  onwards, i.e. sample number two. This is due to the unknown variance that must be estimated from the first sample.*
- (ii) *Independent samples are taken from the process distribution (i.e. from the  $N(\mu_0, \sigma^2)$ ), therefore  $\frac{n_r S_r^2}{\sigma^2}$  and  $\frac{\sum_{i=1}^{r-1} n_i S_{r-1}^{2pooled}}{\sigma^2}$  are independently chi-squared distributed with degrees of freedom  $n_r$  and  $\sum_{i=1}^{r-1} n_i$ , respectively (see Bain and Engelhardt, 1992 [3], p.271).*
- (iii) *Furthermore, if the process is in-control,  $\frac{n_r S_r^2}{\sigma^2 n_r} / \frac{\sum_{i=1}^{r-1} n_i S_{r-1}^{2pooled}}{\sigma^2 \sum_{i=1}^{r-1} n_i} = \frac{S_r^2}{S_{r-1}^{2pooled}}$  follows an  $F$  distribution with  $n_r$  and  $\sum_{i=1}^{r-1} n_i$  degrees of freedom (see Bain and Engelhardt, 1992 [3], p.275). This is the reason why the charting statistic is a function of the  $F$  distribution (see the example in Section 1.2 step 3).*
- (iv) *The term charting statistic will be used for the two sample test statistic defined in (2.2) as well as the transformed value thereof that is plotted on the control chart.*

## 2. GENERALISED MULTIVARIATE BETA TYPE II DISTRIBUTIONS

### 2.2. Problem statement

The focus will be on the part where the process is out-of-control, i.e. encountered a shift. The exact distribution of the charting statistic is then unknown because after a change in the process parameter occurred, the charting statistics are no longer independent. Essentially this means that the distribution of the statistic (2.2) is investigated under the alternative hypothesis that the process is out-of-control. To simplify the notation used in expression (2.2), following a change in the process variance between samples  $\kappa - 1$  and  $\kappa$ , define the random variable

$$U_0^* \equiv U_\kappa^* = \frac{S_\kappa^2}{S_{\kappa-1}^{2pooled}}. \quad (2.3)$$

The subscript of the random variable  $U_0^*$  indicates the number of samples after the parameter has changed, with zero indicating that it is the first sample after the process encountered a permanent upward or downward step shift in the variance.

Consider the sample variance, i.e.  $S_i^2$ , before and after the shift in the process variance took place:

**Before the shift in the variance:**

Samples:  $i = 1, 2, \dots, \kappa - 1$

Distribution:  $Y_{ik} \sim N(\mu_0, \sigma^2)$

$$S_i^2 = \frac{1}{n_i} \sum_{k=1}^{n_i} (Y_{ik} - \mu_0)^2$$

$$\frac{n_i S_i^2}{\sigma^2} \sim \chi^2(n_i)$$

**After the shift in the variance:**

Samples:  $i = \kappa, \kappa + 1, \dots$

Distribution:  $Y_{ik} \sim N(\mu_0, \sigma_1^2 = \lambda\sigma^2)$

$$S_i^2 = \frac{1}{n_i} \sum_{k=1}^{n_i} (Y_{ik} - \mu_0)^2$$

$$\frac{n_i S_i^2}{\sigma_1^2} \sim \chi^2(n_i)$$

#### Remark 2.2

(i)  $\chi^2(n_i)$  denotes the central chi-squared distribution with degrees of freedom  $n_i$  (see (B.31)).

(ii) The degrees of freedom is assumed to be  $n_i$ , since the mean is not estimated because it is assumed that the mean is a fixed / deterministic value. In case the mean is unknown and has to be estimated too, the degrees of freedom changes from  $n_i$  to  $n_i - 1$  and the  $\mu_0$  would be replaced by  $\hat{\mu}_0$ , i.e. a point estimate of  $\mu_0$ .

## 2. GENERALISED MULTIVARIATE BETA TYPE II DISTRIBUTIONS

### 2.2. Problem statement

Following a change in the variance between samples  $\kappa - 1$  and  $\kappa$ , (2.3) can be rewritten as:

$$\begin{aligned}
 U_0^* &= \frac{S_\kappa^2}{S_{\kappa-1}^{2pooled}} \\
 &= \sum_{i=1}^{\kappa-1} n_i \times \frac{S_\kappa^2}{\sum_{i=1}^{\kappa-1} n_i S_i^2} \\
 &= \frac{\sum_{i=1}^{\kappa-1} n_i}{n_\kappa} \times \frac{\frac{n_\kappa S_\kappa^2}{\sigma_1^2} \times \frac{\sigma_1^2}{\sigma^2}}{\sum_{i=1}^{\kappa-1} \frac{n_i S_i^2}{\sigma^2}} \\
 &= \frac{\sum_{i=1}^{\kappa-1} n_i}{n_\kappa} \times \frac{\lambda W_0}{X}, \tag{2.4}
 \end{aligned}$$

$$\text{where } \lambda = \frac{\sigma_1^2}{\sigma^2}, \tag{2.5}$$

$$W_0 \equiv \frac{n_\kappa S_\kappa^2}{\sigma_1^2} \sim \chi^2(n_\kappa) \text{ and}$$

$$X \equiv \sum_{i=1}^{\kappa-1} \frac{n_i S_i^2}{\sigma^2} \sim \chi^2(a) \text{ with } a = \sum_{i=1}^{\kappa-1} n_i.$$

Note that  $\lambda$  indicates the unknown size of the shift in the variance. In general, at sample  $\kappa + j$ , where  $\kappa > 1$  and  $j = 1, 2, \dots, p$  define the following sequence of random variables (all based on the two sample test statistic for testing the equality of variances):

$$\begin{aligned}
 U_j^* &= \frac{S_{\kappa+j}^2}{S_{\kappa+j-1}^{2pooled}} \\
 &= \sum_{i=1}^{\kappa+j-1} n_i \times \frac{S_{\kappa+j}^2}{\sum_{i=1}^{\kappa-1} n_i S_i^2 + \sum_{i=\kappa}^{\kappa+j-1} n_i S_i^2} \\
 &= \frac{\sum_{i=1}^{\kappa+j-1} n_i}{n_{\kappa+j}} \times \frac{\frac{n_{\kappa+j} S_{\kappa+j}^2}{\sigma_1^2} \times \frac{\sigma_1^2}{\sigma^2}}{\sum_{i=1}^{\kappa-1} \frac{n_i S_i^2}{\sigma^2} + \sum_{i=\kappa}^{\kappa+j-1} \frac{n_i S_i^2}{\sigma_1^2} \times \frac{\sigma_1^2}{\sigma^2}} \\
 &= \frac{\sum_{i=1}^{\kappa+j-1} n_i}{n_{\kappa+j}} \times \frac{\frac{n_{\kappa+j} S_{\kappa+j}^2}{\sigma_1^2} \times \frac{\sigma_1^2}{\sigma^2}}{\sum_{i=1}^{\kappa-1} \frac{n_i S_i^2}{\sigma^2} + \sum_{k=0}^{j-1} \frac{n_{\kappa+k} S_{\kappa+k}^2}{\sigma_1^2} \times \frac{\sigma_1^2}{\sigma^2}} \\
 &= \frac{\sum_{i=1}^{\kappa+j-1} n_i}{n_{\kappa+j}} \times \frac{\lambda W_j}{X + \lambda \sum_{k=0}^{j-1} W_k}, \tag{2.6}
 \end{aligned}$$

## 2. GENERALISED MULTIVARIATE BETA TYPE II DISTRIBUTIONS

### 2.2. Problem statement

$$\begin{aligned} \text{where } \lambda &= \frac{\sigma_1^2}{\sigma^2}, \\ W_i &\equiv \frac{n_{\kappa+i} S_{\kappa+i}^2}{\sigma_1^2} \sim \chi^2(n_{\kappa+i}) \text{ for } i = 0, 1, \dots, j \text{ and} \\ X &\equiv \sum_{i=1}^{\kappa-1} \frac{n_i S_i^2}{\sigma^2} \sim \chi^2(a) \text{ with } a = \sum_{i=1}^{\kappa-1} n_i. \end{aligned}$$

Take note that this is an on-going process and even though  $j$  could theoretically go up to infinity, it will be restricted to  $p$  in this thesis when defining the random variables and determining the joint distribution. This will serve as a cut-off point for the monitoring of the process; therefore only the random variables from immediately after the change in the variance took place up to  $p$  samples afterwards will be considered. However, there is not a restriction placed on the value of  $p$ . The properties of the multivariate and marginal distributions as  $p$  tends to infinity fall outside the scope of this thesis.

To simplify matters going forward and for notational purposes the factors,  $\sum_{i=1}^{\kappa-1} n_i/n_\kappa$  and  $\sum_{i=1}^{\kappa+j-1} n_i/n_{\kappa+j}$  in (2.4) and (2.6) are omitted and the (\*) superscript dropped, since the factors are deterministic and can therefore be incorporated in the control limits when they are calculated (see Chapter 5, Section 5.1.1). Therefore, the random variables of interest for this study are:

$$\begin{aligned} U_0 &= \frac{\lambda W_0}{X}, \\ U_j &= \frac{\lambda W_j}{X + \lambda \sum_{k=0}^{j-1} W_k}, \quad j = 1, 2, \dots, p \text{ and } \lambda > 0, \end{aligned} \tag{2.7}$$

where

$$\begin{aligned} \lambda &= \frac{\sigma_1^2}{\sigma^2} \text{ indicates the unknown size of the shift in the variance,} \\ X &= \sum_{i=1}^{\kappa-1} \chi^2(n_i) \sim \chi^2(a), \text{ i.e. } X \text{ is a chi-squared random variable with degrees of} \\ &\text{freedom } a = \sum_{i=1}^{\kappa-1} n_i, \\ W_i &\sim \chi^2(v_i), \text{ i.e. } W_i \text{ is a chi-squared random variable with degrees of freedom } v_i = n_{\kappa+i} \\ &\text{for } i = 0, 1, \dots, p. \end{aligned}$$

Take note that  $X$  represents the sum of  $\kappa - 1$  independent  $\chi^2$  random variables, i.e.  $\chi^2(n_1), \dots, \chi^2(n_{\kappa-1})$  since it is assumed the samples are independent.

The random variable  $U_0$  corresponds to time period  $\kappa$ , and  $U_j$  to time period  $\kappa + j$ .  $X, W_j$  with  $j = 0, 1, 2, \dots, p$  are independent chi-squared random variables with degrees of freedom  $a$  and  $v_j$  for  $j = 0, 1, 2, \dots, p$ , respectively. The random variable  $X$  relates to the samples before the change in the variance took place, with degrees of freedom  $a = \sum_{i=1}^{\kappa-1} n_i$  which represents the total number of observations (for all samples) before



## 2. GENERALISED MULTIVARIATE BETA TYPE II DISTRIBUTIONS

### 2.3. The generalised multivariate beta type II distribution

---

the shift in the variance occurred. The random variable  $W_j$  for  $j = 0, 1, 2, \dots, p$  relate to the samples after the change in the variance occurred, with degrees of freedom denoted by  $v_j = n_{\kappa+j}$  which represents the sample size of sample  $\kappa + j$ . Take note that  $j = 0$  corresponds to sample  $\kappa$ ,  $j = 1$  to sample  $\kappa + 1$ , and so forth. The parameter  $\lambda$  is deterministic and represent the ratio of the new variance (after the change) with respect to the previous variance (before the change), i.e.  $\lambda = \frac{\sigma_1^2}{\sigma^2}$  and indicates the unknown size of the shift in the variance. The information regarding the time from which the shift occurred ( $\kappa$ ), is contained in the degrees of freedom of the random variable  $X$ ; if samples of equal size ( $n$ ) are taken at equally spaced time periods the degrees of freedom of  $X$  reduces to  $(\kappa - 1) \times n$ .

**Remark 2.3** Consider the case where independent samples each of size  $n \geq 1$  measurements are made on a sequence of items where these values are independent and identically distributed having been collected from an exponential distribution with a parameter  $\theta$  as the unknown process mean. Suppose that from sample  $\kappa$  the process parameter has changed from  $\theta$  to  $\theta_1 = \lambda\theta$  where  $\lambda \neq 1$  and  $\lambda > 0$ . The two sample test statistic for the  $Q$ -chart for comparing the means follows from the likelihood ratio test and is based on the ratio of the mean for a specific sample to the overall mean of all the preceding samples (see Bain and Engelhardt, 1992 [3], p.418). The resulting random variables are the same as (2.7) with  $\lambda = \frac{\theta_1}{\theta}$  indicating the unknown size of the shift in the mean,  $X = \sum_{i=1}^{\kappa-1} \chi^2(2n) \sim \chi^2(a)$ , i.e.  $X$  is a chi-squared random variable with degrees of freedom  $a=2n(\kappa - 1)$  and  $W_i \sim \chi^2(v_i)$ , i.e.  $W_i$  is a chi-squared random variable with degrees of freedom  $v_i = 2n$  for  $i = 0, 1, \dots, p$ . Thus, when monitoring the unknown process mean when observations are from an exponential distribution, the charting statistics are the same as for the case of monitoring the variance when observations are from a normal distribution with the key difference being the fact that it is only the degrees of freedom of the chi-squared random variables that changes. For a detailed discussion the reader is referred to Human and Chakraborti (2010) [17] and Adamski et al.(2012) [1].

The joint distribution of the random variables (2.7) will be derived in the next section.

## 2.3 The generalised multivariate beta type II distribution

In this section the joint probability density function (pdf) of  $U_0, U_1, \dots, U_p$  (see (2.7)) is derived. This distribution is unknown and is important for studying the probabilistic

## 2. GENERALISED MULTIVARIATE BETA TYPE II DISTRIBUTIONS

### 2.3. The generalised multivariate beta type II distribution

properties and performance of the control chart, for example determining the run-length probabilities.

**Theorem 2.1** *Let  $X, W_j$  with  $j = 0, 1, 2, \dots, p$  be independent chi-squared random variables with degrees of freedom  $a$  and  $v_j$  with  $j = 0, 1, 2, \dots, p$ , respectively. Let  $U_0 = \frac{\lambda W_0}{X}$  and  $U_j = \frac{\lambda W_j}{X + \lambda \sum_{k=0}^{j-1} W_k}$  where  $j = 1, 2, \dots, p$  and  $\lambda > 0$ . The pdf of  $U_0, U_1, \dots, U_p$  is given by*

$$f(u_0, u_1, \dots, u_p) = \frac{\Gamma\left(\frac{a}{2} + \sum_{j=0}^p \frac{v_j}{2}\right) \lambda^{\frac{a}{2}}}{\Gamma\left(\frac{a}{2}\right) \prod_{j=0}^p \Gamma\left(\frac{v_j}{2}\right)} \left(\prod_{j=0}^p u_j^{\frac{v_j}{2}-1}\right) \left(\prod_{k=0}^{p-1} (1+u_k)^{\sum_{j=k+1}^p \frac{v_j}{2}}\right) \quad (2.8)$$

$$\times \left(\lambda + u_0 + \sum_{j=1}^p u_j \prod_{k=0}^{j-1} (1+u_k)\right)^{-\left(\frac{a}{2} + \sum_{j=0}^p \frac{v_j}{2}\right)},$$

$$u_j > 0, j = 0, 1, \dots, p,$$

where  $\Gamma(\cdot)$  denotes the gamma function (see (B.1)).

**Proof.** The joint pdf of  $X, W_0, W_1, \dots, W_p$  is

$$f(x, w_0, w_1, \dots, w_p) = \frac{1}{2^{\frac{a}{2} + \sum_{j=0}^p \frac{v_j}{2}} \Gamma\left(\frac{a}{2}\right) \prod_{j=0}^p \Gamma\left(\frac{v_j}{2}\right)} x^{\frac{a}{2}-1} e^{-\frac{x}{2}} \prod_{j=0}^p w_j^{\frac{v_j}{2}-1} e^{-\frac{w_j}{2}}. \quad (2.9)$$

Let  $U = X, U_0 = \frac{\lambda W_0}{X}$  and  $U_j = \frac{\lambda W_j}{X + \lambda \sum_{k=0}^{j-1} W_k}$  where  $j = 1, 2, \dots, p$ .

This gives the inverse transformation,  $X = U, W_0 = \frac{1}{\lambda} U_0 U$  and  $W_j = \frac{1}{\lambda} U_j \left(U + \lambda \sum_{k=0}^{j-1} W_k\right)$  where  $j = 1, 2, \dots, p$ .

Consider  $W_j$  :

$$\text{for } j = 1 : W_1 = \frac{1}{\lambda} U_1 (U + \lambda W_0) = \frac{1}{\lambda} U_1 (U + U_0 U) = \frac{1}{\lambda} U_1 U (1 + U_0),$$

$$\text{for } j = 2 : W_2 = \frac{1}{\lambda} U_2 (U + \lambda W_0 + \lambda W_1) = \frac{1}{\lambda} U_2 (U + U_0 U + U_1 U (1 + U_0))$$

$$= \frac{1}{\lambda} U_2 U (1 + U_0) (1 + U_1).$$

Therefore, by observing the pattern, in general  $W_j = \frac{1}{\lambda} U_j U \prod_{k=0}^{j-1} (1 + U_k)$  where  $j = 1, 2, \dots, p$ .

## 2. GENERALISED MULTIVARIATE BETA TYPE II DISTRIBUTIONS

### 2.3. The generalised multivariate beta type II distribution

The Jacobian of the transformation is,

$$\begin{aligned}
 & J(x, w_0, w_1, \dots, w_p \rightarrow u, u_0, u_1, \dots, u_p) \\
 &= \begin{vmatrix} 1 & 0 & 0 & 0 \\ \frac{u_0}{\lambda} & \frac{u}{\lambda} & 0 & 0 \\ \frac{u_1(1+u_0)}{\lambda} & \frac{u_1 u}{\lambda} & \frac{u(1+u_0)}{\lambda} & 0 \\ \frac{u_2(1+u_0)(1+u_1)}{\lambda} & \frac{u_2 u(1+u_1)}{\lambda} & \frac{u_2 u(1+u_0)}{\lambda} & 0 \\ \vdots & \vdots & \vdots & \ddots \\ \frac{u_p \prod_{k=0}^{p-1} (1+u_k)}{\lambda} & \frac{u_p u \prod_{k=1}^{p-1} (1+u_k)}{\lambda} & \frac{u_p u(1+u_0) \prod_{k=2}^{p-1} (1+u_k)}{\lambda} & \frac{u \prod_{k=0}^{p-1} (1+u_k)}{\lambda} \end{vmatrix} \\
 &= \left(\frac{u}{\lambda}\right)^{p+1} \prod_{j=1}^p \prod_{k=0}^{j-1} (1+u_k) \\
 &= \left(\frac{u}{\lambda}\right)^{p+1} \prod_{j=1}^p [(1+u_0) \dots (1+u_{j-1})] \\
 &= \left(\frac{u}{\lambda}\right)^{p+1} (1+u_0)^p \prod_{j=2}^p [(1+u_1) \dots (1+u_{j-1})] \\
 &= \left(\frac{u}{\lambda}\right)^{p+1} (1+u_0)^p (1+u_1)^{p-1} \prod_{j=3}^p [(1+u_2) \dots (1+u_{j-1})] \\
 &= \left(\frac{u}{\lambda}\right)^{p+1} (1+u_0)^p (1+u_1)^{p-1} (1+u_2)^{p-2} \dots (1+u_{p-1}) \\
 &= \left(\frac{u}{\lambda}\right)^{p+1} \prod_{k=0}^{p-1} (1+u_k)^{p-k}. \tag{2.10}
 \end{aligned}$$

Thus, making the transformation and substituting in (2.9), the joint pdf of  $U, U_0, \dots, U_p$  is given by

$$\begin{aligned}
 & f(u, u_0, u_1, \dots, u_p) \\
 &= \frac{1}{2^{\frac{a}{2} + \sum_{j=0}^p \frac{v_j}{2}} \Gamma\left(\frac{a}{2}\right) \prod_{j=0}^p \Gamma\left(\frac{v_j}{2}\right)} u^{\frac{a}{2}-1} e^{-\frac{u}{2}} \left(\frac{1}{\lambda} u_0 u\right)^{\frac{v_0}{2}-1} e^{-\frac{(\frac{1}{\lambda} u_0 u)}{2}} \\
 & \quad \times \prod_{j=1}^p \left( \left[ \frac{1}{\lambda} u_j u \prod_{k=0}^{j-1} (1+u_k) \right]^{\frac{v_j}{2}-1} e^{-\frac{(\frac{1}{\lambda} u_j u \prod_{k=0}^{j-1} (1+u_k))}{2}} \right) \left(\frac{u}{\lambda}\right)^{p+1} \prod_{k=0}^{p-1} (1+u_k)^{p-k}
 \end{aligned}$$

## 2. GENERALISED MULTIVARIATE BETA TYPE II DISTRIBUTIONS

### 2.3. The generalised multivariate beta type II distribution

$$\begin{aligned}
&= \frac{\lambda^{-\sum_{j=0}^p \frac{v_j}{2}}}{2^{\frac{a}{2} + \sum_{j=0}^p \frac{v_j}{2}} \Gamma\left(\frac{a}{2}\right) \prod_{j=0}^p \Gamma\left(\frac{v_j}{2}\right)} u^{\frac{a}{2} + \sum_{j=0}^p \frac{v_j}{2} - 1} u_0^{\frac{v_0}{2} - 1} \left( \prod_{j=1}^p u_j^{\frac{v_j}{2} - 1} \right) \\
&\times \left( \prod_{j=1}^p \left[ \prod_{k=0}^{j-1} (1 + u_k) \right]^{\frac{v_j}{2} - 1} \right) \left( \prod_{k=0}^{p-1} (1 + u_k)^{p-k} \right) \\
&\times e^{-\frac{u}{2} \left( 1 + \frac{u_0}{\lambda} + \sum_{j=1}^p \frac{u_j}{\lambda} \prod_{k=0}^{j-1} (1 + u_k) \right)}.
\end{aligned} \tag{2.11}$$

Consider the term  $\prod_{j=1}^p \left[ \prod_{k=0}^{j-1} (1 + u_k) \right]^{\frac{v_j}{2} - 1}$  in (2.11):

$$\text{for } j = 1 : (1 + u_0)^{\frac{v_1}{2} - 1},$$

$$\text{for } j = 2 : [(1 + u_0)(1 + u_1)]^{\frac{v_2}{2} - 1},$$

⋮

$$\text{for } j = p : [(1 + u_0)(1 + u_1) \dots (1 + u_{p-1})]^{\frac{v_p}{2} - 1}.$$

Therefore,

$$\prod_{j=1}^p \left[ \prod_{k=0}^{j-1} (1 + u_k) \right]^{\frac{v_j}{2} - 1} = \prod_{k=0}^{p-1} (1 + u_k)^{\sum_{j=k+1}^p \frac{v_j}{2} - (p-k)}. \tag{2.12}$$

Substituting (2.12) in (2.11) gives

$$\begin{aligned}
&f(u, u_0, u_1, \dots, u_p) \\
&= \frac{\lambda^{-\sum_{j=0}^p \frac{v_j}{2}}}{2^{\frac{a}{2} + \sum_{j=0}^p \frac{v_j}{2}} \Gamma\left(\frac{a}{2}\right) \prod_{j=0}^p \Gamma\left(\frac{v_j}{2}\right)} u^{\frac{a}{2} + \sum_{j=0}^p \frac{v_j}{2} - 1} \left( \prod_{j=0}^p u_j^{\frac{v_j}{2} - 1} \right) \\
&\times \left( \prod_{k=0}^{p-1} (1 + u_k)^{\sum_{j=k+1}^p \frac{v_j}{2} - (p-k)} \right) \left( \prod_{k=0}^{p-1} (1 + u_k)^{p-k} \right) e^{-\frac{u}{2} \left( 1 + \frac{u_0}{\lambda} + \sum_{j=1}^p \frac{u_j}{\lambda} \prod_{k=0}^{j-1} (1 + u_k) \right)} \\
&= \frac{\lambda^{-\sum_{j=0}^p \frac{v_j}{2}}}{2^{\frac{a}{2} + \sum_{j=0}^p \frac{v_j}{2}} \Gamma\left(\frac{a}{2}\right) \prod_{j=0}^p \Gamma\left(\frac{v_j}{2}\right)} u^{\frac{a}{2} + \sum_{j=0}^p \frac{v_j}{2} - 1} \left( \prod_{j=0}^p u_j^{\frac{v_j}{2} - 1} \right) \\
&\times \left( \prod_{k=0}^{p-1} (1 + u_k)^{\sum_{j=k+1}^p \frac{v_j}{2}} \right) e^{-\frac{u}{2} \left( 1 + \frac{u_0}{\lambda} + \sum_{j=1}^p \frac{u_j}{\lambda} \prod_{k=0}^{j-1} (1 + u_k) \right)}.
\end{aligned} \tag{2.13}$$

## 2. GENERALISED MULTIVARIATE BETA TYPE II DISTRIBUTIONS

### 2.3. The generalised multivariate beta type II distribution

Now, integrating (2.13) with respect to  $u$  using (B.18), yields the desired result (2.8) after simplification,

$$\begin{aligned}
 & f(u_0, u_1, \dots, u_p) \\
 &= \frac{\lambda^{-\sum_{j=0}^p \frac{v_j}{2}}}{2^{\frac{a}{2} + \sum_{j=0}^p \frac{v_j}{2}} \Gamma\left(\frac{a}{2}\right) \prod_{j=0}^p \Gamma\left(\frac{v_j}{2}\right)} \left( \prod_{j=0}^p u_j^{\frac{v_j}{2} - 1} \right) \left( \prod_{k=0}^{p-1} (1 + u_k)^{\sum_{j=k+1}^p \frac{v_j}{2}} \right) \\
 & \quad \times \int_0^\infty u^{\frac{a}{2} + \sum_{j=0}^p \frac{v_j}{2} - 1} e^{-\frac{u}{\lambda} \left( 1 + \frac{u_0}{\lambda} + \sum_{j=1}^p \frac{u_j}{\lambda} \prod_{k=0}^{j-1} (1 + u_k) \right)} du \\
 &= \frac{\lambda^{-\sum_{j=0}^p \frac{v_j}{2}}}{2^{\frac{a}{2} + \sum_{j=0}^p \frac{v_j}{2}} \Gamma\left(\frac{a}{2}\right) \prod_{j=0}^p \Gamma\left(\frac{v_j}{2}\right)} \left( \prod_{j=0}^p u_j^{\frac{v_j}{2} - 1} \right) \left( \prod_{k=0}^{p-1} (1 + u_k)^{\sum_{j=k+1}^p \frac{v_j}{2}} \right) \\
 & \quad \times \Gamma\left(\frac{a}{2} + \sum_{j=0}^p \frac{v_j}{2}\right) \left( \frac{1 + \frac{u_0}{\lambda} + \sum_{j=1}^p \frac{u_j}{\lambda} \prod_{k=0}^{j-1} (1 + u_k)}{2} \right)^{-\left(\frac{a}{2} + \sum_{j=1}^p \frac{v_j}{2}\right)} \\
 &= \frac{\Gamma\left(\frac{a}{2} + \sum_{j=0}^p \frac{v_j}{2}\right) \lambda^{\frac{a}{2}}}{\Gamma\left(\frac{a}{2}\right) \prod_{j=0}^p \Gamma\left(\frac{v_j}{2}\right)} \left( \prod_{j=0}^p u_j^{\frac{v_j}{2} - 1} \right) \left( \prod_{k=0}^{p-1} (1 + u_k)^{\sum_{j=k+1}^p \frac{v_j}{2}} \right) \\
 & \quad \times \left( \lambda + u_0 + \sum_{j=1}^p u_j \prod_{k=0}^{j-1} (1 + u_k) \right)^{-\left(\frac{a}{2} + \sum_{j=0}^p \frac{v_j}{2}\right)}.
 \end{aligned}$$

■

**Remark 2.4** The joint distribution of  $U_0, U_1, \dots, U_p$  (see (2.7)) derived in Theorem 2.1 gives rise to a new distribution that can be regarded as the generalised multivariate beta type II distribution. The random variables in (2.7) are constructed from independent chi-squared random variables using the variables-in-common (or trivariate reduction) technique and the resulting distribution is defined on the positive domain. A literature overview of relevant multivariate beta type II distributions is briefly discussed in order to contextualise the new distribution (2.8). Tiao and Guttman (1965) [45] obtained a multivariate analogue of the beta type II distribution (see (B.29)) by performing the appropriate transformation on the Dirichlet distribution. Note that the beta type II distribution is also referred to as the inverted beta distribution or the betaprime distribution. They also considered an alternative development through stochastic representation. Suppose that  $X, W_j$  with  $j = 0, 1, 2, \dots, p$  are independent chi-squared random variables as men-

## 2. GENERALISED MULTIVARIATE BETA TYPE II DISTRIBUTIONS

### 2.3. The generalised multivariate beta type II distribution

tioned in Theorem 2.1, but with degrees of freedom  $2a$  and  $2v_j$  with  $j = 0, 1, 2, \dots, p$ , respectively. Define

$$U_j = \frac{W_j}{X} \text{ where } j = 0, 1, 2, \dots, p. \quad (2.14)$$

The pdf of  $U_0, U_1, \dots, U_p$  is

$$f(u_0, u_1, \dots, u_p) = \frac{\Gamma\left(a + \sum_{j=0}^p v_j\right)}{\Gamma(a) \prod_{j=0}^p \Gamma(v_j)} \left( \prod_{j=0}^p u_j^{v_j-1} \right) \left( 1 + \sum_{j=0}^p u_j \right)^{-\left(a + \sum_{j=0}^p v_j\right)}, \quad (2.15)$$

$$u_j > 0, j = 0, 1, \dots, p.$$

Tiao and Guttman (1965) [45] named this the inverted Dirichlet distribution. In literature this is also referred to as the standard inverted Dirichlet distribution, the multivariate inverted beta distribution or the type II Dirichlet distribution. The distribution (2.15) can also be obtained by supposing  $X, W_j$  have standard gamma distributions. For a thorough discussion on the inverted Dirichlet distribution see Kotz et al. (2000) [26], p.485 and Ng et al. (2011) [35], p.175. Libby and Novick (1982) [27] derived the generalised  $F$  distribution from ratios of independent gamma variables. Let  $X, W_j$  with  $j = 0, 1, 2, \dots, p$  be independent gamma distributed random variables with parameters  $\beta_a, a$  and  $\beta_j, v_j$  with  $j = 0, 1, 2, \dots, p$ , respectively. The joint pdf of the random variables in (2.14) is

$$f(u_0, u_1, \dots, u_p) = \frac{\Gamma\left(a + \sum_{j=0}^p v_j\right)}{\Gamma(a) \prod_{j=0}^p \Gamma(v_j)} \left( \prod_{j=0}^p \left( \frac{\beta_a}{\beta_j} \right)^{v_j} u_j^{v_j-1} \right) \times \left( 1 + \sum_{j=0}^p \frac{\beta_a}{\beta_j} u_j \right)^{-\left(a + \sum_{j=0}^p v_j\right)}, \quad (2.16)$$

$$u_j > 0, j = 0, 1, \dots, p.$$

Note that substituting  $\frac{\beta_a}{\beta_j} = 1$  in (2.16), the generalised  $F$  distribution reduces to the inverted Dirichlet distribution in (2.15). Rada-Mora and Nagar (2007) [42] extended the generalised beta type II distribution given in Patil et al. (1984) [37] to obtain a multivariate generalisation. The stochastic representation and the resulting pdf follow. Let  $X, W_j$  with  $j = 0, 1, 2, \dots, p$  be independent standard gamma distributed random variables and define

$$U_j = b \left( \frac{W_j}{X} \right)^{\frac{1}{c}} \text{ for } j = 0, 1, 2, \dots, p, \quad (2.17)$$

## 2. GENERALISED MULTIVARIATE BETA TYPE II DISTRIBUTIONS

### 2.3. The generalised multivariate beta type II distribution

where  $c \neq 0$  and  $b > 0$  are constants. The joint pdf of the random variables in (2.17) is

$$\begin{aligned}
 f(u_0, u_1, \dots, u_p) &= \frac{\Gamma\left(a + \sum_{j=0}^p v_j\right)}{\Gamma(a) \prod_{j=0}^p \Gamma(v_j) b^c \sum_{j=0}^p v_j} |c|^{p+1} \left( \prod_{j=0}^p u_j^{cv_j-1} \right) \\
 &\quad \times \left( 1 + \sum_{j=0}^p \left( \frac{u_j}{b} \right)^c \right)^{-\left(a + \sum_{j=0}^p v_j\right)}, \\
 &\quad u_j > 0, j = 0, 1, \dots, p.
 \end{aligned} \tag{2.18}$$

Substituting  $c = b = 1$  in (2.18), the pdf reduces to the inverted Dirichlet in (2.15).

**Remark 2.5** It is important to note that there exists a known relationship between the beta type I distribution and the beta type II distribution. Several beta type I distributions have been proposed in literature, see for example Gupta and Wong (1985) [15], Jones (2001) [23], Olkin and Liu (2003) [36], Nadarajah and Kotz (2005) [33], Nadarajah (2009) [34], Arnold and Ng (2011) [2]. For an overview of the beta type I distribution consider Gupta and Nadarajah (2004) [12], Johnson et al. (1995) [22], Balakrishnan and Lai (2009) [4] and Kotz et al. (2000) [26].

The next two lemmas derive alternative expressions for the multivariate generalised beta type II distribution given in (2.8).

**Lemma 2.3.1** An alternative expression for the joint pdf in (2.8) in terms of the binomial series,  ${}_1F_0(\cdot)$  (see (B.7)) is

$$\begin{aligned}
 f(u_0, u_1, \dots, u_p) &= \frac{\Gamma\left(\frac{a}{2} + \sum_{j=0}^p \frac{v_j}{2}\right) \lambda^{\frac{a}{2}}}{\Gamma\left(\frac{a}{2}\right) \prod_{j=0}^p \Gamma\left(\frac{v_j}{2}\right)} \left( \prod_{j=0}^p u_j^{\frac{v_j}{2}-1} \right) \\
 &\quad \times \left( \prod_{k=0}^p (1+u_k)^{-\left(\frac{a}{2} + \sum_{j=0}^k \frac{v_j}{2}\right)} \right) \\
 &\quad \times {}_1F_0\left(\frac{a}{2} + \sum_{j=0}^p \frac{v_j}{2}; \frac{1-\lambda}{\prod_{k=0}^p (1+u_k)}\right), \\
 &\quad u_j > 0, j = 0, 1, \dots, p, \left| \frac{1-\lambda}{\prod_{k=0}^p (1+u_k)} \right| < 1.
 \end{aligned} \tag{2.19}$$

## 2. GENERALISED MULTIVARIATE BETA TYPE II DISTRIBUTIONS

### 2.3. The generalised multivariate beta type II distribution

**Proof.** Consider the term  $\left(\lambda + u_0 + \sum_{j=1}^p u_j \prod_{k=0}^{j-1} (1 + u_k)\right)^{-\left(\frac{a}{2} + \sum_{j=0}^p \frac{v_j}{2}\right)}$  in (2.8),

$$\begin{aligned}
& \lambda + u_0 + \sum_{j=1}^p u_j \prod_{k=0}^{j-1} (1 + u_k) \\
&= \lambda + u_0 + u_1 (1 + u_0) + \sum_{j=2}^p u_j \prod_{k=0}^{j-1} (1 + u_k) \\
&= \lambda + 1 + u_0 + u_1 (1 + u_0) + \sum_{j=2}^p u_j \prod_{k=0}^{j-1} (1 + u_k) - 1 \\
&= \lambda + (1 + u_0) (1 + u_1) + \sum_{j=2}^p u_j \prod_{k=0}^{j-1} (1 + u_k) - 1 \\
&= \lambda + (1 + u_0) (1 + u_1) + u_2 (1 + u_0) (1 + u_1) + \sum_{j=3}^p u_j \prod_{k=0}^{j-1} (1 + u_k) - 1 \\
&= \lambda + (1 + u_0) (1 + u_1) (1 + u_2) + \sum_{j=3}^p u_j \prod_{k=0}^{j-1} (1 + u_k) - 1 \\
&= \lambda + \prod_{k=0}^p (1 + u_k) - 1. \tag{2.20}
\end{aligned}$$

Substituting (2.20) in (2.8) and multiplying it with  $\frac{\prod_{k=0}^p (1 + u_k)}{\prod_{k=0}^p (1 + u_k)}$ , gives

$$\begin{aligned}
& f(u_0, u_1, \dots, u_p) \\
&= \frac{\Gamma\left(\frac{a}{2} + \sum_{j=0}^p \frac{v_j}{2}\right) \lambda^{\frac{a}{2}}}{\Gamma\left(\frac{a}{2}\right) \prod_{j=0}^p \Gamma\left(\frac{v_j}{2}\right)} \left(\prod_{j=0}^p u_j^{\frac{v_j}{2}-1}\right) \left(\prod_{k=0}^{p-1} (1 + u_k)^{\sum_{j=k+1}^p \frac{v_j}{2}}\right) \\
& \quad \times \left(\left[\lambda + \prod_{k=0}^p (1 + u_k) - 1\right] \frac{\prod_{k=0}^p (1 + u_k)}{\prod_{k=0}^p (1 + u_k)}\right)^{-\left(\frac{a}{2} + \sum_{j=0}^p \frac{v_j}{2}\right)} \\
&= \frac{\Gamma\left(\frac{a}{2} + \sum_{j=0}^p \frac{v_j}{2}\right) \lambda^{\frac{a}{2}}}{\Gamma\left(\frac{a}{2}\right) \prod_{j=0}^p \Gamma\left(\frac{v_j}{2}\right)} \left(\prod_{j=0}^p u_j^{\frac{v_j}{2}-1}\right) \left(\prod_{k=0}^{p-1} (1 + u_k)^{\sum_{j=k+1}^p \frac{v_j}{2}}\right) \\
& \quad \times \left(\frac{\lambda + \prod_{k=0}^p (1 + u_k) - 1}{\prod_{k=0}^p (1 + u_k)}\right)^{-\left(\frac{a}{2} + \sum_{j=0}^p \frac{v_j}{2}\right)} \left(\prod_{k=0}^p (1 + u_k)\right)^{-\left(\frac{a}{2} + \sum_{j=0}^p \frac{v_j}{2}\right)}
\end{aligned}$$



## 2. GENERALISED MULTIVARIATE BETA TYPE II DISTRIBUTIONS

### 2.3. The generalised multivariate beta type II distribution

$$\begin{aligned}
 &= \frac{\Gamma\left(\frac{a}{2} + \sum_{j=0}^p \frac{v_j}{2}\right) \lambda^{\frac{a}{2}}}{\Gamma\left(\frac{a}{2}\right) \prod_{j=0}^p \Gamma\left(\frac{v_j}{2}\right)} \left(\prod_{j=0}^p u_j^{\frac{v_j}{2}-1}\right) \left(\prod_{k=0}^p (1+u_k)^{-\left(\frac{a}{2} + \sum_{j=0}^k \frac{v_j}{2}\right)}\right) \\
 &\quad \times \left(\frac{\lambda + \prod_{k=0}^p (1+u_k) - 1}{\prod_{k=0}^p (1+u_k)}\right)^{-\left(\frac{a}{2} + \sum_{j=0}^p \frac{v_j}{2}\right)}. \tag{2.21}
 \end{aligned}$$

Note that

$$\begin{aligned}
 &\left(\prod_{k=0}^{p-1} (1+u_k)^{\sum_{j=k+1}^p \frac{v_j}{2}}\right) \left(\prod_{k=0}^p (1+u_k)\right)^{-\left(\frac{a}{2} + \sum_{j=0}^p \frac{v_j}{2}\right)} \\
 &= \left(\prod_{k=0}^{p-1} (1+u_k)^{\sum_{j=k+1}^p \frac{v_j}{2}}\right) \left(\prod_{k=0}^{p-1} (1+u_k)\right)^{-\left(\frac{a}{2} + \sum_{j=0}^p \frac{v_j}{2}\right)} (1+u_p)^{-\left(\frac{a}{2} + \sum_{j=0}^p \frac{v_j}{2}\right)} \\
 &= \left(\prod_{k=0}^{p-1} (1+u_k)^{-\left(\frac{a}{2} + \sum_{j=0}^k \frac{v_j}{2}\right)}\right) (1+u_p)^{-\left(\frac{a}{2} + \sum_{j=0}^p \frac{v_j}{2}\right)} \\
 &= \prod_{k=0}^p (1+u_k)^{-\left(\frac{a}{2} + \sum_{j=0}^k \frac{v_j}{2}\right)}. \tag{2.22}
 \end{aligned}$$

Expression (2.21) can be simplified to the desired result (2.19) using (B.7) with

$$1 - x = \frac{\lambda + \prod_{k=0}^p (1+u_k) - 1}{\prod_{k=0}^p (1+u_k)}.$$

Then  $x = -\left(\frac{\lambda + \prod_{k=0}^p (1+u_k) - 1}{\prod_{k=0}^p (1+u_k)} - 1\right) = \frac{1 - \lambda}{\prod_{k=0}^p (1+u_k)}$  with  $\left|\frac{1 - \lambda}{\prod_{k=0}^p (1+u_k)}\right| < 1$ .

Therefore,

$$\begin{aligned}
 &f(u_0, u_1, \dots, u_p) \\
 &= \frac{\Gamma\left(\frac{a}{2} + \sum_{j=0}^p \frac{v_j}{2}\right) \lambda^{\frac{a}{2}}}{\Gamma\left(\frac{a}{2}\right) \prod_{j=0}^p \Gamma\left(\frac{v_j}{2}\right)} \left(\prod_{j=0}^p u_j^{\frac{v_j}{2}-1}\right) \left(\prod_{k=0}^p (1+u_k)^{-\left(\frac{a}{2} + \sum_{j=0}^k \frac{v_j}{2}\right)}\right) \\
 &\quad \times {}_1F_0\left(\frac{a}{2} + \sum_{j=0}^p \frac{v_j}{2}; \frac{1 - \lambda}{\prod_{k=0}^p (1+u_k)}\right).
 \end{aligned}$$

■

## 2. GENERALISED MULTIVARIATE BETA TYPE II DISTRIBUTIONS

### 2.3. The generalised multivariate beta type II distribution

**Lemma 2.3.2** *The joint pdf of  $(U_0, U_1, \dots, U_p)$  in (2.8) can also be expressed in terms of the product of beta type II pdfs,*

$$f(u_0, u_1, \dots, u_p) = \lambda^{\frac{a}{2}} \sum_{b=0}^{\infty} \frac{\left(\frac{a}{2}\right)_b}{b!} (1 - \lambda)^b \prod_{j=0}^p \text{Beta}^{II} \left( \frac{v_j}{2}, \frac{a}{2} + \sum_{k=0}^{j-1} \frac{v_k}{2} + b \right), \quad (2.23)$$

$$u_j > 0, \quad j = 0, 1, \dots, p,$$

where  $\text{Beta}^{II}(\cdot, \cdot)$  denotes the known beta type II pdf defined in (B.29) and  $(\cdot)_b$  is the Pochhammer coefficient defined in (B.4).

**Proof.** Expanding  ${}_1F_0(\cdot)$  in expression (2.19) in series form (see (B.7)), gives

$$\begin{aligned} & f(u_0, u_1, \dots, u_p) \\ &= \frac{\Gamma\left(\frac{a}{2} + \sum_{j=0}^p \frac{v_j}{2}\right) \lambda^{\frac{a}{2}}}{\Gamma\left(\frac{a}{2}\right) \prod_{j=0}^p \Gamma\left(\frac{v_j}{2}\right)} \left( \prod_{j=0}^p u_j^{\frac{v_j}{2}-1} \right) \left( \prod_{k=0}^p (1 + u_k)^{-\left(\frac{a}{2} + \sum_{j=0}^k \frac{v_j}{2}\right)} \right) \\ & \times \sum_{b=0}^{\infty} \frac{\left(\frac{a}{2} + \sum_{j=0}^p \frac{v_j}{2}\right)_b}{b!} \left[ \frac{1 - \lambda}{\prod_{k=0}^p (1 + u_k)} \right]^b. \end{aligned}$$

Rewriting the Pochhammer coefficient in terms of gamma functions, (see (B.4)), gives

$$\begin{aligned} & f(u_0, u_1, \dots, u_p) \\ &= \frac{\Gamma\left(\frac{a}{2} + \sum_{j=0}^p \frac{v_j}{2}\right) \lambda^{\frac{a}{2}}}{\Gamma\left(\frac{a}{2}\right) \prod_{j=0}^p \Gamma\left(\frac{v_j}{2}\right)} \sum_{b=0}^{\infty} \frac{\Gamma\left(\frac{a}{2} + \sum_{j=0}^p \frac{v_j}{2} + b\right)}{\Gamma\left(\frac{a}{2} + \sum_{j=0}^p \frac{v_j}{2}\right) b!} (1 - \lambda)^b \left( \prod_{j=0}^p u_j^{\frac{v_j}{2}-1} \right) \\ & \times \left( \prod_{k=0}^p (1 + u_k)^{-\left(\frac{a}{2} + \sum_{j=0}^k \frac{v_j}{2} + b\right)} \right). \end{aligned}$$

Rearranging the terms, using (B.4) and (B.29), yields the desired result (2.23),

$$\begin{aligned} & f(u_0, u_1, \dots, u_p) \\ &= \lambda^{\frac{a}{2}} \sum_{b=0}^{\infty} \frac{\Gamma\left(\frac{a}{2} + b\right)}{\Gamma\left(\frac{a}{2}\right) b!} (1 - \lambda)^b \frac{\Gamma\left(\frac{a}{2} + \sum_{j=0}^p \frac{v_j}{2} + b\right)}{\Gamma\left(\frac{a}{2} + b\right) \prod_{j=0}^p \Gamma\left(\frac{v_j}{2}\right)} \left( \prod_{j=0}^p u_j^{\frac{v_j}{2}-1} \right) \\ & \times \left( \prod_{k=0}^p (1 + u_k)^{-\left(\frac{a}{2} + \sum_{j=0}^k \frac{v_j}{2} + b\right)} \right) \end{aligned}$$

## 2. GENERALISED MULTIVARIATE BETA TYPE II DISTRIBUTIONS

### 2.4. Marginal generalised beta type II distributions

$$\begin{aligned}
 &= \lambda^{\frac{a}{2}} \sum_{b=0}^{\infty} \frac{\left(\frac{a}{2}\right)_b}{b!} (1-\lambda)^b \frac{\Gamma\left(\frac{a}{2} + \sum_{j=0}^p \frac{v_j}{2} + b\right)}{\Gamma\left(\frac{a}{2} + b\right) \prod_{j=0}^p \Gamma\left(\frac{v_j}{2}\right)} \\
 &\quad \times \prod_{j=0}^p u_j^{\frac{v_j}{2}-1} (1+u_j)^{-\left(\frac{a}{2} + \sum_{k=0}^j \frac{v_k}{2} + b\right)} \\
 &= \lambda^{\frac{a}{2}} \sum_{b=0}^{\infty} \frac{\left(\frac{a}{2}\right)_b}{b!} (1-\lambda)^b \prod_{j=0}^p \text{Beta}^{II}\left(\frac{v_j}{2}, \frac{a}{2} + \sum_{k=0}^{j-1} \frac{v_k}{2} + b\right).
 \end{aligned}$$

■

This alternative representation of the joint pdf is used in some of the subsequent derivations.

**Remark 2.6** For  $\lambda = 1$  (see (2.5)) the process variance did not encounter a shift and therefore the process is in-control. Using (2.20), (2.22), the joint pdf (2.8) simplifies to

$$\begin{aligned}
 &f(u_0, u_1, \dots, u_p) \\
 &= \frac{\Gamma\left(\frac{a}{2} + \sum_{j=0}^p \frac{v_j}{2}\right)}{\Gamma\left(\frac{a}{2}\right) \prod_{j=0}^p \Gamma\left(\frac{v_j}{2}\right)} \left(\prod_{j=0}^p u_j^{\frac{v_j}{2}-1}\right) \left(\prod_{k=0}^{p-1} (1+u_k)^{\sum_{j=k+1}^p \frac{v_j}{2}}\right) \\
 &\quad \times \left(1 + u_0 + \sum_{j=1}^p u_j \prod_{k=0}^{j-1} (1+u_k)\right)^{-\left(\frac{a}{2} + \sum_{j=0}^p \frac{v_j}{2}\right)} \\
 &= \frac{\Gamma\left(\frac{a}{2} + \sum_{j=0}^p \frac{v_j}{2}\right)}{\Gamma\left(\frac{a}{2}\right) \prod_{j=0}^p \Gamma\left(\frac{v_j}{2}\right)} \left(\prod_{j=0}^p u_j^{\frac{v_j}{2}-1}\right) \left(\prod_{k=0}^{p-1} (1+u_k)^{\sum_{j=k+1}^p \frac{v_j}{2}}\right) \\
 &\quad \times \left(\prod_{k=0}^p (1+u_k)\right)^{-\left(\frac{a}{2} + \sum_{j=0}^p \frac{v_j}{2}\right)} \\
 &= \frac{\Gamma\left(\frac{a}{2} + \sum_{j=0}^p \frac{v_j}{2}\right)}{\Gamma\left(\frac{a}{2}\right) \prod_{j=0}^p \Gamma\left(\frac{v_j}{2}\right)} \left(\prod_{j=0}^p u_j^{\frac{v_j}{2}-1}\right) \left(\prod_{k=0}^p (1+u_k)^{-\left(\frac{a}{2} + \sum_{j=0}^k \frac{v_j}{2}\right)}\right), \\
 &\quad u_j > 0, j = 0, 1, \dots, p.
 \end{aligned}$$

The latter expression is a product of independent beta type II pdfs (see (B.29)). This confirms the independency of the random variables when  $\lambda = 1$ .

## 2.4 Marginal generalised beta type II distributions

This section focuses on the pdf of any subset of random variables of the generalised multivariate beta type II distribution derived in (2.8). The marginal pdf of  $U_j$ ,  $j =$

## 2. GENERALISED MULTIVARIATE BETA TYPE II DISTRIBUTIONS

### 2.4. Marginal generalised beta type II distributions

$0, 1, \dots, p$ , is derived in Section 2.4.1. In Section 2.4.2 the bivariate pdf of  $(U_j, U_{j+m})$ ,  $j = 0, 1, 2, \dots, p$ ,  $m = 1, 2, 3, \dots$  is derived which will be used to investigate the correlation structure discussed in Section 2.6. This section is concluded with the derivation of the pdf of a subset of  $(U_0, U_1, \dots, U_p)$  in Section 2.4.3. The marginal distributions derived in this section will also be used to determine the moments in Section 2.5.

#### 2.4.1 Generalised univariate beta type II distribution

**Theorem 2.2** *Let  $X, W_j$  with  $j = 0, 1, 2, \dots, p$  be independent chi-squared random variables with degrees of freedom  $a$  and  $v_j$  with  $j = 0, 1, 2, \dots, p$  respectively. Let  $U_0 = \frac{\lambda W_0}{X}$  and  $U_j = \frac{\lambda W_j}{X + \lambda \sum_{k=0}^{j-1} W_k}$  where  $j = 1, 2, \dots, p$  and  $\lambda > 0$ . If the joint pdf of  $U_0, U_1, \dots, U_p$  is given by (2.8), then the marginal pdf of*

(a)  $U_0$  is given by

$$f(u_0) = \frac{\Gamma(\frac{a}{2} + \frac{v_0}{2}) \lambda^{\frac{a}{2}}}{\Gamma(\frac{a}{2}) \Gamma(\frac{v_0}{2})} u_0^{\frac{v_0}{2}-1} (\lambda + u_0)^{-\left(\frac{a}{2} + \frac{v_0}{2}\right)}, \quad u_0 > 0, \quad (2.24)$$

(b)  $U_j, j = 1, 2, \dots, p$  is given by

$$\begin{aligned} f(u_j) &= \frac{\Gamma\left(\frac{a}{2} + \sum_{k=0}^j \frac{v_k}{2}\right)}{\Gamma\left(\frac{v_j}{2}\right) \Gamma\left(\frac{a}{2} + \sum_{k=0}^{j-1} \frac{v_k}{2}\right)} \lambda^{\frac{a}{2}} u_j^{\frac{v_j}{2}-1} (1 + u_j)^{-\left(\frac{a}{2} + \sum_{k=0}^j \frac{v_k}{2}\right)} \\ &\times {}_2F_1\left(\frac{a}{2} + \sum_{k=0}^j \frac{v_k}{2}, \frac{a}{2}; \frac{a}{2} + \sum_{k=0}^{j-1} \frac{v_k}{2}; \frac{1 - \lambda}{1 + u_j}\right), \\ &u_j > 0, \quad \left| \frac{1 - \lambda}{1 + u_j} \right| < 1, \end{aligned} \quad (2.25)$$

where  ${}_2F_1(\cdot)$  denotes the Gauss hypergeometric function defined in (B.10).

**Proof.** (a) For  $j = 0$ , the marginal pdf of  $U_0$  can be obtained using a similar approach as in Theorem 2.1. The joint pdf of  $W_0$  and  $X$  is given by

$$f(w_0, x) = \frac{1}{2^{\frac{a}{2} + \frac{v_0}{2}} \Gamma\left(\frac{v_0}{2}\right) \Gamma\left(\frac{a}{2}\right)} w_0^{\frac{v_0}{2}-1} x^{\frac{a}{2}-1} e^{-\frac{w_0}{2} - \frac{x}{2}}.$$

## 2. GENERALISED MULTIVARIATE BETA TYPE II DISTRIBUTIONS

### 2.4. Marginal generalised beta type II distributions

By applying the transformation  $U_0 = \frac{\lambda W_0}{X}$  with Jacobian,

$$J(w_0, x \rightarrow u_0, x) = \begin{vmatrix} \frac{x}{\lambda} & \frac{u_0}{\lambda} \\ 0 & 1 \end{vmatrix} = \frac{x}{\lambda},$$

the joint pdf of  $U_0$  and  $X$  is

$$f(u_0, x) = \frac{\lambda^{-\frac{v_0}{2}}}{2^{\frac{a}{2} + \frac{v_0}{2}} \Gamma\left(\frac{v_0}{2}\right) \Gamma\left(\frac{a}{2}\right)} u_0^{\frac{v_0}{2} - 1} x^{\frac{a}{2} + \frac{v_0}{2} - 1} e^{-\frac{x}{\lambda}(u_0 + 1)}. \quad (2.26)$$

The marginal pdf of  $U_0$  is obtained by integrating (2.26) with respect to  $x$  using (B.18),

$$\begin{aligned} f(u_0) &= \frac{\lambda^{-\frac{v_0}{2}}}{2^{\frac{a}{2} + \frac{v_0}{2}} \Gamma\left(\frac{v_0}{2}\right) \Gamma\left(\frac{a}{2}\right)} u_0^{\frac{v_0}{2} - 1} \int_0^\infty x^{\frac{a}{2} + \frac{v_0}{2} - 1} e^{-\frac{x}{\lambda}(u_0 + 1)} dx \\ &= \frac{\lambda^{-\frac{v_0}{2}}}{2^{\frac{a}{2} + \frac{v_0}{2}} \Gamma\left(\frac{v_0}{2}\right) \Gamma\left(\frac{a}{2}\right)} u_0^{\frac{v_0}{2} - 1} \Gamma\left(\frac{a}{2} + \frac{v_0}{2}\right) \left(\frac{u_0 + 1}{\lambda}\right)^{-\left(\frac{a}{2} + \frac{v_0}{2}\right)} \\ &= \frac{\Gamma\left(\frac{a}{2} + \frac{v_0}{2}\right) \lambda^{\frac{a}{2}}}{\Gamma\left(\frac{v_0}{2}\right) \Gamma\left(\frac{a}{2}\right)} u_0^{\frac{v_0}{2} - 1} (u_0 + \lambda)^{-\left(\frac{a}{2} + \frac{v_0}{2}\right)}. \end{aligned}$$

(b) Let  $T = \sum_{k=0}^{j-1} W_k$ , therefore  $T$  has a  $\chi^2$  distribution with parameter  $\sum_{k=0}^{j-1} \frac{v_k}{2}$ . The joint pdf of  $W_j, X$  and  $T$  is given by

$$f(w_j, x, t) = \frac{1}{2^{\frac{a}{2} + \sum_{k=0}^j \frac{v_k}{2}} \Gamma\left(\frac{v_j}{2}\right) \Gamma\left(\frac{a}{2}\right) \Gamma\left(\sum_{k=0}^{j-1} \frac{v_k}{2}\right)} w_j^{\frac{v_j}{2} - 1} x^{\frac{a}{2} - 1} t^{\sum_{k=0}^{j-1} \frac{v_k}{2} - 1} e^{-\frac{w_j}{2} - \frac{x}{2} - \frac{t}{2}}.$$

Applying the transformation  $Y = X + \lambda T$  and  $U_j = \frac{\lambda W_j}{X + \lambda T}$ , gives the inverse transformation  $X = Y - \lambda T$  and  $W_j = \frac{1}{\lambda} U_j (X + \lambda T) = \frac{1}{\lambda} U_j Y$ , with Jacobian,

$$J(w_j, x, t \rightarrow u_j, y, t) = \begin{vmatrix} \frac{y}{\lambda} & \frac{u_j}{\lambda} & 0 \\ 0 & 1 & -\lambda \\ 0 & 0 & 1 \end{vmatrix} = \frac{y}{\lambda}.$$

## 2. GENERALISED MULTIVARIATE BETA TYPE II DISTRIBUTIONS

### 2.4. Marginal generalised beta type II distributions

The joint pdf of  $U_j, Y$  and  $T$  is

$$\begin{aligned}
 f(u_j, y, t) &= \frac{1}{2^{\frac{a}{2} + \sum_{k=0}^{j-1} \frac{v_k}{2}} \Gamma\left(\frac{v_j}{2}\right) \Gamma\left(\frac{a}{2}\right) \Gamma\left(\sum_{k=0}^{j-1} \frac{v_k}{2}\right)} \left(\frac{1}{\lambda} u_j y\right)^{\frac{v_j}{2}-1} (y - \lambda t)^{\frac{a}{2}-1} t^{\sum_{k=0}^{j-1} \frac{v_k}{2}-1} \\
 &\quad \times e^{-\frac{1}{2}\left(\frac{1}{\lambda} u_j y\right) - \frac{1}{2}(y - \lambda t) - \frac{1}{2} \frac{y}{\lambda}} \\
 &= \frac{\lambda^{\frac{a}{2} - \frac{v_j}{2} - 1}}{2^{\frac{a}{2} + \sum_{k=0}^{j-1} \frac{v_k}{2}} \Gamma\left(\frac{v_j}{2}\right) \Gamma\left(\frac{a}{2}\right) \Gamma\left(\sum_{k=0}^{j-1} \frac{v_k}{2}\right)} u_j^{\frac{v_j}{2}-1} y^{\frac{v_j}{2}} \left(\frac{y}{\lambda} - t\right)^{\frac{a}{2}-1} t^{\sum_{k=0}^{j-1} \frac{v_k}{2}-1} e^{-\frac{y}{2}\left(1 + \frac{u_j}{\lambda}\right) - \frac{1}{2}(1-\lambda)}.
 \end{aligned}$$

Therefore, integrating with respect to  $t$  and  $y$ , the marginal pdf of  $U_j$  is

$$\begin{aligned}
 f(u_j) &= \frac{\lambda^{\frac{a}{2} - \frac{v_j}{2} - 1}}{2^{\frac{a}{2} + \sum_{k=0}^{j-1} \frac{v_k}{2}} \Gamma\left(\frac{v_j}{2}\right) \Gamma\left(\frac{a}{2}\right) \Gamma\left(\sum_{k=0}^{j-1} \frac{v_k}{2}\right)} u_j^{\frac{v_j}{2}-1} \int_0^\infty y^{\frac{v_j}{2}} e^{-\frac{y}{2}\left(1 + \frac{u_j}{\lambda}\right)} \\
 &\quad \times \int_0^{\frac{y}{\lambda}} t^{\sum_{k=0}^{j-1} \frac{v_k}{2}-1} \left(\frac{y}{\lambda} - t\right)^{\frac{a}{2}-1} e^{-\frac{1}{2}(1-\lambda)} dt dy. \tag{2.27}
 \end{aligned}$$

Let  $I_1 = \int_0^\infty y^{\frac{v_j}{2}} e^{-\frac{y}{2}\left(1 + \frac{u_j}{\lambda}\right)} \int_0^{\frac{y}{\lambda}} t^{\sum_{k=0}^{j-1} \frac{v_k}{2}-1} \left(\frac{y}{\lambda} - t\right)^{\frac{a}{2}-1} e^{-\frac{1}{2}(1-\lambda)} dt dy$ . Integrating  $I_1$  with respect to  $t$  using (B.21), gives

$$\begin{aligned}
 I_1 &= \int_0^\infty y^{\frac{v_j}{2}} e^{-\frac{y}{2}\left(1 + \frac{u_j}{\lambda}\right)} \frac{\Gamma\left(\frac{a}{2}\right) \Gamma\left(\sum_{k=0}^{j-1} \frac{v_k}{2}\right)}{\Gamma\left(\frac{a}{2} + \sum_{k=0}^{j-1} \frac{v_k}{2}\right)} \left(\frac{y}{\lambda}\right)^{\frac{a}{2} + \sum_{k=0}^{j-1} \frac{v_k}{2} - 1} \\
 &\quad \times {}_1F_1\left(\sum_{k=0}^{j-1} \frac{v_k}{2}; \frac{a}{2} + \sum_{k=0}^{j-1} \frac{v_k}{2}; \frac{(\lambda-1)y}{2\lambda}\right) dy \\
 &= \frac{\Gamma\left(\frac{a}{2}\right) \Gamma\left(\sum_{k=0}^{j-1} \frac{v_k}{2}\right) \lambda^{-\left(\frac{a}{2} + \sum_{k=0}^{j-1} \frac{v_k}{2} - 1\right)}}{\Gamma\left(\frac{a}{2} + \sum_{k=0}^{j-1} \frac{v_k}{2}\right)} \int_0^\infty y^{\frac{a}{2} + \sum_{k=0}^{j-1} \frac{v_k}{2} - 1} e^{-\frac{y}{2}\left(1 + \frac{u_j}{\lambda}\right)} \\
 &\quad \times {}_1F_1\left(\sum_{k=0}^{j-1} \frac{v_k}{2}; \frac{a}{2} + \sum_{k=0}^{j-1} \frac{v_k}{2}; \frac{(\lambda-1)y}{2\lambda}\right) dy, \tag{2.28}
 \end{aligned}$$

where  ${}_1F_1$  denotes confluent hypergeometric series or Kummer's hypergeometric series (see (B.9)). Solving the integral in (2.28) using (B.22) gives

## 2. GENERALISED MULTIVARIATE BETA TYPE II DISTRIBUTIONS

### 2.4. Marginal generalised beta type II distributions

$$\begin{aligned}
I_1 &= \frac{\Gamma\left(\frac{a}{2}\right) \Gamma\left(\sum_{k=0}^{j-1} \frac{v_k}{2}\right) \lambda^{-\left(\frac{a}{2} + \sum_{k=0}^{j-1} \frac{v_k}{2} - 1\right)}}{\Gamma\left(\frac{a}{2} + \sum_{k=0}^{j-1} \frac{v_k}{2}\right)} \Gamma\left(\frac{a}{2} + \sum_{k=0}^j \frac{v_k}{2}\right) \left[\frac{1}{2} \left(1 + \frac{u_j}{\lambda}\right)\right]^{-\left(\frac{a}{2} + \sum_{k=0}^j \frac{v_k}{2}\right)} \\
&\times {}_2F_1\left(\sum_{k=0}^{j-1} \frac{v_k}{2}, \frac{a}{2} + \sum_{k=0}^j \frac{v_k}{2}; \frac{a}{2} + \sum_{k=0}^{j-1} \frac{v_k}{2}; \frac{\lambda-1}{2\lambda} \left(1 + \frac{u_j}{\lambda}\right)\right) \\
&= \frac{\Gamma\left(\frac{a}{2}\right) \Gamma\left(\sum_{k=0}^{j-1} \frac{v_k}{2}\right) \Gamma\left(\frac{a}{2} + \sum_{k=0}^j \frac{v_k}{2}\right) \lambda^{-\left(\frac{a}{2} + \sum_{k=0}^{j-1} \frac{v_k}{2} - 1\right)} 2^{\frac{a}{2} + \sum_{k=0}^j \frac{v_k}{2}}}{\Gamma\left(\frac{a}{2} + \sum_{k=0}^{j-1} \frac{v_k}{2}\right)} \\
&\times \left(1 + \frac{u_j}{\lambda}\right)^{-\left(\frac{a}{2} + \sum_{k=0}^j \frac{v_k}{2}\right)} {}_2F_1\left(\sum_{k=0}^{j-1} \frac{v_k}{2}, \frac{a}{2} + \sum_{k=0}^j \frac{v_k}{2}; \frac{a}{2} + \sum_{k=0}^{j-1} \frac{v_k}{2}; \frac{\lambda-1}{2\lambda} \left(1 + \frac{u_j}{\lambda}\right)\right). \tag{2.29}
\end{aligned}$$

Rewriting the Gauss hypergeometric function,  ${}_2F_1(\cdot)$ , in (2.29) using (B.23) with  $x = \frac{\frac{\lambda-1}{\lambda}}{\left(1 + \frac{u_j}{\lambda}\right)} = \frac{\lambda-1}{\lambda + u_j}$  gives

$$\begin{aligned}
I_1 &= \frac{\Gamma\left(\frac{a}{2}\right) \Gamma\left(\sum_{k=0}^{j-1} \frac{v_k}{2}\right) \Gamma\left(\frac{a}{2} + \sum_{k=0}^j \frac{v_k}{2}\right) \lambda^{-\left(\frac{a}{2} + \sum_{k=0}^{j-1} \frac{v_k}{2} - 1\right)} 2^{\frac{a}{2} + \sum_{k=0}^j \frac{v_k}{2}}}{\Gamma\left(\frac{a}{2} + \sum_{k=0}^{j-1} \frac{v_k}{2}\right)} \left(1 + \frac{u_j}{\lambda}\right)^{-\left(\frac{a}{2} + \sum_{k=0}^j \frac{v_k}{2}\right)} \\
&\times \left(\frac{1 + u_j}{\lambda + u_j}\right)^{-\left(\frac{a}{2} + \sum_{k=0}^j \frac{v_k}{2}\right)} {}_2F_1\left(\frac{a}{2} + \sum_{k=0}^j \frac{v_k}{2}, \frac{a}{2}; \frac{a}{2} + \sum_{k=0}^{j-1} \frac{v_k}{2}; \frac{1-\lambda}{1+u_j}\right) \\
&= \frac{\Gamma\left(\frac{a}{2}\right) \Gamma\left(\sum_{k=0}^{j-1} \frac{v_k}{2}\right) \Gamma\left(\frac{a}{2} + \sum_{k=0}^j \frac{v_k}{2}\right) \lambda^{-\left(\frac{a}{2} + \sum_{k=0}^{j-1} \frac{v_k}{2} - 1\right)} 2^{\frac{a}{2} + \sum_{k=0}^j \frac{v_k}{2}}}{\Gamma\left(\frac{a}{2} + \sum_{k=0}^{j-1} \frac{v_k}{2}\right)} \left(\frac{1}{\lambda}\right)^{-\left(\frac{a}{2} + \sum_{k=0}^j \frac{v_k}{2}\right)} \\
&\times (\lambda + u_j)^{-\left(\frac{a}{2} + \sum_{k=0}^j \frac{v_k}{2}\right)} \left(\frac{1 + u_j}{\lambda + u_j}\right)^{-\left(\frac{a}{2} + \sum_{k=0}^j \frac{v_k}{2}\right)} {}_2F_1\left(\frac{a}{2} + \sum_{k=0}^j \frac{v_k}{2}, \frac{a}{2}; \frac{a}{2} + \sum_{k=0}^{j-1} \frac{v_k}{2}; \frac{1-\lambda}{1+u_j}\right) \\
&= \frac{\Gamma\left(\frac{a}{2}\right) \Gamma\left(\sum_{k=0}^{j-1} \frac{v_k}{2}\right) \Gamma\left(\frac{a}{2} + \sum_{k=0}^j \frac{v_k}{2}\right) \lambda^{\frac{v_j}{2} + 1} 2^{\frac{a}{2} + \sum_{k=0}^j \frac{v_k}{2}}}{\Gamma\left(\frac{a}{2} + \sum_{k=0}^{j-1} \frac{v_k}{2}\right)} (\lambda + u_j)^{-\left(\frac{a}{2} + \sum_{k=0}^j \frac{v_k}{2}\right)} \\
&\times \left(\frac{1 + u_j}{\lambda + u_j}\right)^{-\left(\frac{a}{2} + \sum_{k=0}^j \frac{v_k}{2}\right)} {}_2F_1\left(\frac{a}{2} + \sum_{k=0}^j \frac{v_k}{2}, \frac{a}{2}; \frac{a}{2} + \sum_{k=0}^{j-1} \frac{v_k}{2}; \frac{1-\lambda}{1+u_j}\right). \tag{2.30}
\end{aligned}$$

Substituting (2.30) back in (2.27) yields the desired result (2.25). ■

## 2. GENERALISED MULTIVARIATE BETA TYPE II DISTRIBUTIONS

### 2.4. Marginal generalised beta type II distributions

**Remark 2.7** If  $\lambda = 1$ , i.e. when the process is in-control, the marginal pdf of  $U_j$ ,  $j = 0, 1, 2, \dots, p$  (see (2.24), (2.25)) simplifies to a beta type II pdf (see (B.29)) with parameters  $\frac{v_j}{2}$  and  $\frac{a}{2} + \sum_{k=0}^{j-1} \frac{v_k}{2}$ , i.e.

$$f(u_j) = \frac{\Gamma\left(\frac{a}{2} + \sum_{k=0}^j \frac{v_k}{2}\right)}{\Gamma\left(\frac{v_j}{2}\right) \Gamma\left(\frac{a}{2} + \sum_{k=0}^{j-1} \frac{v_k}{2}\right)} u_j^{\frac{v_j}{2}-1} (1+u_j)^{-\left(\frac{a}{2} + \sum_{k=0}^j \frac{v_k}{2}\right)}, \quad u_j > 0.$$

**Remark 2.8** Remark 2.7 mentions that the beta type II distribution (see (B.29)) is a special case of the newly derived generalised univariate beta type II distribution (see (2.25)). Next a short discussion follows of univariate beta type II distributions. The stochastic representation of the beta type II distribution as well as other univariate beta distributions that is defined on the positive domain will be considered. Let  $X$  and  $W_0$  be independent chi-squared random variables with degrees of freedom  $a$  and  $v_0$  respectively. The random variable  $U'_0 = \frac{W_0/v_0}{X/a}$  has an  $F$  distribution with  $v_0$  and  $a$  degrees of freedom with pdf (see (B.30))

$$f(u'_0) = \frac{\Gamma\left(\frac{a}{2} + \frac{v_0}{2}\right)}{\Gamma\left(\frac{v_0}{2}\right) \Gamma\left(\frac{a}{2}\right)} \left(\frac{v_0}{a}\right)^{\frac{v_0}{2}} u'^{\frac{v_0}{2}-1} \left(1 + \frac{v_0}{a} u'_0\right)^{-\left(\frac{a}{2} + \frac{v_0}{2}\right)}, \quad u'_0 > 0.$$

The beta type II distribution is just a multiple of the  $F$  distribution, i.e.

$$U_0 = \frac{W_0}{X}, \quad (2.31)$$

with pdf (see (B.29))

$$f(u_0) = \frac{\Gamma\left(\frac{a}{2} + \frac{v_0}{2}\right)}{\Gamma\left(\frac{v_0}{2}\right) \Gamma\left(\frac{a}{2}\right)} u_0^{\frac{v_0}{2}-1} (1+u_0)^{-\left(\frac{a}{2} + \frac{v_0}{2}\right)}, \quad u_0 > 0.$$

The generalised betaprime distribution given in Patil et al. (1984) [37] (also see Malik (1967) [28]) is derived assuming  $W_0$  and  $X$  in (2.31) have generalised gamma distributions with parameters  $(0, \beta_0, v_0, c)$  and  $(0, \beta_a, a, c)$ , respectively. The pdf is given by

$$f(u_0) = \frac{\Gamma(a+v_0)}{\Gamma(a)\Gamma(v_0)} c \left(\frac{\beta_a}{\beta_0}\right)^{v_0 c} u_0^{v_0 c-1} \left(1 + \left(\frac{\beta_a}{\beta_0} u_0\right)^c\right)^{-(a+v_0)}, \quad u_0 > 0. \quad (2.32)$$



## 2. GENERALISED MULTIVARIATE BETA TYPE II DISTRIBUTIONS

### 2.4. Marginal generalised beta type II distributions

Substituting  $c = 1$  in (2.32) gives the marginal distribution of the generalised  $F$  distribution (2.16) proposed by Libby and Novick (1982) [27] with pdf

$$f(u_0) = \frac{\Gamma(a + v_0)}{\Gamma(a)\Gamma(v_0)} \left(\frac{\beta_a}{\beta_0}\right)^{v_0} u_0^{v_0-1} \left(1 + \frac{\beta_a}{\beta_0} u_0\right)^{-(a+v_0)}, \quad u_0 > 0. \quad (2.33)$$

This distribution (2.33) can also be obtained by determining the distribution of (2.31) assuming  $X$  and  $W_0$  are independent two parameter gamma random variables.

**Remark 2.9** It is important to take note that the marginal pdf of  $U_0$  in (2.24) is also the marginal generalised  $F$  distribution in (2.33),

$$\begin{aligned} f(u_0) &= \frac{\Gamma(\frac{a}{2} + \frac{v_0}{2})\lambda^{\frac{a}{2}}}{\Gamma(\frac{a}{2})\Gamma(\frac{v_0}{2})} u_0^{\frac{v_0}{2}-1} (\lambda + u_0)^{-(\frac{a}{2} + \frac{v_0}{2})} \\ &= \frac{\Gamma(\frac{a}{2} + \frac{v_0}{2})}{\Gamma(\frac{a}{2})\Gamma(\frac{v_0}{2})} \lambda^{-\frac{v_0}{2}} u_0^{\frac{v_0}{2}-1} \left(1 + \frac{1}{\lambda} u_0\right)^{-(\frac{a}{2} + \frac{v_0}{2})}, \quad u_0 > 0. \end{aligned}$$

#### 2.4.2 Generalised bivariate beta type II distribution

**Theorem 2.3** Let  $X, W_j$  with  $j = 0, 1, 2, \dots, p$  be independent chi-squared random variables with degrees of freedom  $a$  and  $v_j$  with  $j = 0, 1, 2, \dots, p$  respectively. Let  $U_0 = \frac{\lambda W_0}{X}$  and  $U_j = \frac{\lambda W_j}{X + \lambda \sum_{k=0}^{j-1} W_k}$  where  $j = 1, 2, \dots, p$  and  $\lambda > 0$ . If the joint pdf of  $U_0, U_1, \dots, U_p$  is given by (2.8), then the bivariate pdf of  $U_j$  and  $U_{j+m}$  is given by

$$\begin{aligned} &f(u_j, u_{j+m}) \\ &= \lambda^{\frac{a}{2}} \sum_{b=0}^{\infty} \frac{\left(\frac{a}{2}\right)_b}{b!} (1 - \lambda)^b \times \text{Beta}^{II} \left( \frac{v_j}{2}, \frac{a}{2} + \sum_{k=0}^{j-1} \frac{v_k}{2} + b \right) \end{aligned} \quad (2.34)$$

$$\begin{aligned} &\times \text{Beta}^{II} \left( \frac{v_{j+m}}{2}, \frac{a}{2} + \sum_{k=0}^{j+m-1} \frac{v_k}{2} + b \right) \\ &= \frac{\lambda^{\frac{a}{2}} \Gamma\left(\frac{a}{2} + \sum_{k=0}^j \frac{v_k}{2}\right) \Gamma\left(\frac{a}{2} + \sum_{k=0}^{j+m} \frac{v_k}{2}\right)}{\Gamma\left(\frac{v_j}{2}\right) \Gamma\left(\frac{v_{j+m}}{2}\right) \Gamma\left(\frac{a}{2} + \sum_{k=0}^{j-1} \frac{v_k}{2}\right) \Gamma\left(\frac{a}{2} + \sum_{k=0}^{j+m-1} \frac{v_k}{2}\right)} u_j^{\frac{v_j}{2}-1} u_{j+m}^{\frac{v_{j+m}}{2}-1} \\ &\times (1 + u_j)^{-\left(\frac{a}{2} + \sum_{k=0}^j \frac{v_k}{2}\right)} (1 + u_{j+m})^{-\left(\frac{a}{2} + \sum_{k=0}^{j+m} \frac{v_k}{2}\right)} \\ &\times {}_3F_2 \left( \frac{a}{2} + \sum_{k=0}^{j+m} \frac{v_k}{2}, \frac{a}{2} + \sum_{k=0}^j \frac{v_k}{2}, \frac{a}{2}; \frac{a}{2} + \sum_{k=0}^{j+m-1} \frac{v_k}{2}, \frac{a}{2} + \sum_{k=0}^{j-1} \frac{v_k}{2}; \frac{1 - \lambda}{(1 + u_j)(1 + u_{j+m})} \right), \\ &u_j, u_{j+m} > 0, \quad j = 0, 1, \dots, p, \quad m = 1, 2, \dots, \quad \left| \frac{1 - \lambda}{(1 + u_j)(1 + u_{j+m})} \right| < 1, \end{aligned} \quad (2.35)$$

## 2. GENERALISED MULTIVARIATE BETA TYPE II DISTRIBUTIONS

### 2.4. Marginal generalised beta type II distributions

where  ${}_3F_2(\cdot)$  denotes the hypergeometric function (see (B.5)).

**Proof.** Expression (2.34) follows from integrating the appropriate variables from the joint pdf in the form given in (2.23).

Expression (2.35) in terms of the hypergeometric function,  ${}_3F_2(\cdot)$ , follows from expanding the product of the beta type II pdfs, rearranging the terms and simplifying,

$$\begin{aligned}
 & f(u_j, u_{j+m}) \\
 &= \lambda^{\frac{a}{2}} \sum_{b=0}^{\infty} \frac{\left(\frac{a}{2}\right)_b}{b!} (1-\lambda)^b \times \text{Beta}^{II} \left( \frac{v_j}{2}, \frac{a}{2} + \sum_{k=0}^{j-1} \frac{v_k}{2} + b \right) \times \text{Beta}^{II} \left( \frac{v_{j+m}}{2}, \frac{a}{2} + \sum_{k=0}^{j+m-1} \frac{v_k}{2} + b \right) \\
 &= \lambda^{\frac{a}{2}} \sum_{b=0}^{\infty} \frac{\left(\frac{a}{2}\right)_b}{b!} (1-\lambda)^b \frac{\Gamma\left(\frac{a}{2} + \sum_{k=0}^j \frac{v_k}{2} + b\right)}{\Gamma\left(\frac{v_j}{2}\right) \Gamma\left(\frac{a}{2} + \sum_{k=0}^{j-1} \frac{v_k}{2} + b\right)} u_j^{\frac{v_j}{2}-1} (1+u_j)^{-\left(\frac{a}{2} + \sum_{k=0}^j \frac{v_k}{2} + b\right)} \\
 &\quad \times \frac{\Gamma\left(\frac{a}{2} + \sum_{k=0}^{j+m} \frac{v_k}{2} + b\right)}{\Gamma\left(\frac{v_{j+m}}{2}\right) \Gamma\left(\frac{a}{2} + \sum_{k=0}^{j+m-1} \frac{v_k}{2} + b\right)} u_{j+m}^{\frac{v_{j+m}}{2}-1} (1+u_{j+m})^{-\left(\frac{a}{2} + \sum_{k=0}^{j+m} \frac{v_k}{2} + b\right)} \\
 &= \frac{\lambda^{\frac{a}{2}}}{\Gamma\left(\frac{v_j}{2}\right) \Gamma\left(\frac{v_{j+m}}{2}\right)} u_j^{\frac{v_j}{2}-1} (1+u_j)^{-\left(\frac{a}{2} + \sum_{k=0}^j \frac{v_k}{2}\right)} u_{j+m}^{\frac{v_{j+m}}{2}-1} (1+u_{j+m})^{-\left(\frac{a}{2} + \sum_{k=0}^{j+m} \frac{v_k}{2}\right)} \\
 &\quad \times \sum_{b=0}^{\infty} \frac{\Gamma\left(\frac{a}{2} + \sum_{k=0}^{j+m} \frac{v_k}{2} + b\right) \Gamma\left(\frac{a}{2} + \sum_{k=0}^j \frac{v_k}{2} + b\right) \Gamma\left(\frac{a}{2} + b\right)}{\Gamma\left(\frac{a}{2} + \sum_{k=0}^{j+m-1} \frac{v_k}{2} + b\right) \Gamma\left(\frac{a}{2} + \sum_{k=0}^{j-1} \frac{v_k}{2} + b\right) \Gamma\left(\frac{a}{2}\right) b!} \left( \frac{1-\lambda}{(1+u_j)(1+u_{j+m})} \right)^b \\
 &= \frac{\lambda^{\frac{a}{2}} \Gamma\left(\frac{a}{2} + \sum_{k=0}^j \frac{v_k}{2}\right) \Gamma\left(\frac{a}{2} + \sum_{k=0}^{j+m} \frac{v_k}{2}\right)}{\Gamma\left(\frac{v_j}{2}\right) \Gamma\left(\frac{v_{j+m}}{2}\right) \Gamma\left(\frac{a}{2} + \sum_{k=0}^{j-1} \frac{v_k}{2}\right) \Gamma\left(\frac{a}{2} + \sum_{k=0}^{j+m-1} \frac{v_k}{2}\right)} u_j^{\frac{v_j}{2}-1} (1+u_j)^{-\left(\frac{a}{2} + \sum_{k=0}^j \frac{v_k}{2}\right)} \\
 &\quad \times u_{j+m}^{\frac{v_{j+m}}{2}-1} (1+u_{j+m})^{-\left(\frac{a}{2} + \sum_{k=0}^{j+m} \frac{v_k}{2}\right)} \\
 &\quad \times \sum_{b=0}^{\infty} \frac{\left(\frac{a}{2} + \sum_{k=0}^{j+m} \frac{v_k}{2}\right)_b \left(\frac{a}{2} + \sum_{k=0}^j \frac{v_k}{2}\right)_b \left(\frac{a}{2}\right)_b}{\left(\frac{a}{2} + \sum_{k=0}^{j+m-1} \frac{v_k}{2}\right)_b \left(\frac{a}{2} + \sum_{k=0}^{j-1} \frac{v_k}{2}\right)_b b!} \left( \frac{1-\lambda}{(1+u_j)(1+u_{j+m})} \right)^b \\
 &= \frac{\lambda^{\frac{a}{2}} \Gamma\left(\frac{a}{2} + \sum_{k=0}^j \frac{v_k}{2}\right) \Gamma\left(\frac{a}{2} + \sum_{k=0}^{j+m} \frac{v_k}{2}\right)}{\Gamma\left(\frac{v_j}{2}\right) \Gamma\left(\frac{v_{j+m}}{2}\right) \Gamma\left(\frac{a}{2} + \sum_{k=0}^{j-1} \frac{v_k}{2}\right) \Gamma\left(\frac{a}{2} + \sum_{k=0}^{j+m-1} \frac{v_k}{2}\right)} u_j^{\frac{v_j}{2}-1} \\
 &\quad \times (1+u_j)^{-\left(\frac{a}{2} + \sum_{k=0}^j \frac{v_k}{2}\right)} u_{j+m}^{\frac{v_{j+m}}{2}-1} (1+u_{j+m})^{-\left(\frac{a}{2} + \sum_{k=0}^{j+m} \frac{v_k}{2}\right)} \\
 &\quad \times {}_3F_2 \left( \frac{a}{2} + \sum_{k=0}^{j+m} \frac{v_k}{2}, \frac{a}{2} + \sum_{k=0}^j \frac{v_k}{2}, \frac{a}{2}; \frac{a}{2} + \sum_{k=0}^{j+m-1} \frac{v_k}{2}, \frac{a}{2} + \sum_{k=0}^{j-1} \frac{v_k}{2}; \frac{1-\lambda}{(1+u_j)(1+u_{j+m})} \right). \quad \blacksquare
 \end{aligned}$$

## 2. GENERALISED MULTIVARIATE BETA TYPE II DISTRIBUTIONS

### 2.4. Marginal generalised beta type II distributions

**Remark 2.10** *In the following three remarks the cases if  $m = 1$  and/or  $j = 0$  in expression (2.35) is considered, since the form of the bivariate pdf will be illustrated for these cases in Section 2.6.*

(i) If  $m = 1$ ,

$$\begin{aligned}
 & f(u_j, u_{j+1}) \\
 &= \frac{\lambda^{\frac{a}{2}} \Gamma\left(\frac{a}{2} + \sum_{k=0}^{j+1} \frac{v_k}{2}\right)}{\Gamma\left(\frac{v_j}{2}\right) \Gamma\left(\frac{v_{j+1}}{2}\right) \Gamma\left(\frac{a}{2} + \sum_{k=0}^{j-1} \frac{v_k}{2}\right)} \\
 & \times u_j^{\frac{v_j}{2}-1} (1+u_j)^{-\left(\frac{a}{2} + \sum_{k=0}^j \frac{v_k}{2}\right)} u_{j+1}^{\frac{v_{j+1}}{2}-1} (1+u_{j+1})^{-\left(\frac{a}{2} + \sum_{k=0}^{j+1} \frac{v_k}{2}\right)} \\
 & \times {}_2F_1\left(\frac{a}{2} + \sum_{k=0}^{j+1} \frac{v_k}{2}, \frac{a}{2}; \frac{a}{2} + \sum_{k=0}^{j-1} \frac{v_k}{2}; \frac{1-\lambda}{(1+u_j)(1+u_{j+1})}\right), \\
 & \quad u_j, u_{j+1} > 0, \left| \frac{1-\lambda}{(1+u_j)(1+u_{j+1})} \right| < 1.
 \end{aligned} \tag{2.36}$$

(ii) If  $j = 0$ ,

$$\begin{aligned}
 & f(u_0, u_m) \\
 &= \frac{\lambda^{\frac{a}{2}} \Gamma\left(\frac{a}{2} + \frac{v_0}{2}\right) \Gamma\left(\frac{a}{2} + \sum_{k=0}^m \frac{v_k}{2}\right)}{\Gamma\left(\frac{v_0}{2}\right) \Gamma\left(\frac{v_m}{2}\right) \Gamma\left(\frac{a}{2}\right) \Gamma\left(\frac{a}{2} + \sum_{k=0}^{m-1} \frac{v_k}{2}\right)} \\
 & \times u_0^{\frac{v_0}{2}-1} (1+u_0)^{-\left(\frac{a}{2} + \frac{v_0}{2}\right)} u_m^{\frac{v_m}{2}-1} (1+u_m)^{-\left(\frac{a}{2} + \sum_{k=0}^m \frac{v_k}{2}\right)} \\
 & \times {}_2F_1\left(\frac{a}{2} + \sum_{k=0}^m \frac{v_k}{2}, \frac{a}{2} + \frac{v_0}{2}; \frac{a}{2} + \sum_{k=0}^{m-1} \frac{v_k}{2}; \frac{1-\lambda}{(1+u_0)(1+u_m)}\right), \\
 & \quad u_0, u_m > 0, \left| \frac{1-\lambda}{(1+u_0)(1+u_m)} \right| < 1.
 \end{aligned} \tag{2.37}$$

Take note in this case  $\sum_{k=0}^{j-1} \frac{v_k}{2} = 0$  for  $j < 1$ .

(iii) If  $j = 0, m = 1$ ,

$$\begin{aligned}
 & f(u_0, u_1) \\
 &= \frac{\lambda^{\frac{a}{2}} \Gamma\left(\frac{a}{2} + \frac{v_0}{2} + \frac{v_1}{2}\right)}{\Gamma\left(\frac{a}{2}\right) \Gamma\left(\frac{v_0}{2}\right) \Gamma\left(\frac{v_1}{2}\right)} u_0^{\frac{v_0}{2}-1} (1+u_0)^{-\left(\frac{a}{2} + \frac{v_0}{2}\right)} u_1^{\frac{v_1}{2}-1} (1+u_1)^{-\left(\frac{a}{2} + \frac{v_0}{2} + \frac{v_1}{2}\right)} \\
 & \times {}_1F_0\left(\frac{a}{2} + \frac{v_0}{2} + \frac{v_1}{2}; \frac{1-\lambda}{(1+u_0)(1+u_1)}\right), \quad \left| \frac{1-\lambda}{(1+u_0)(1+u_1)} \right| < 1
 \end{aligned} \tag{2.38}$$

## 2. GENERALISED MULTIVARIATE BETA TYPE II DISTRIBUTIONS

### 2.4. Marginal generalised beta type II distributions

$$= \frac{\lambda^{\frac{a}{2}} \Gamma(\frac{a}{2} + \frac{v_0}{2} + \frac{v_1}{2})}{\Gamma(\frac{a}{2}) \Gamma(\frac{v_0}{2}) \Gamma(\frac{v_1}{2})} u_0^{\frac{v_0}{2}-1} (1+u_0)^{\frac{v_1}{2}} u_1^{\frac{v_1}{2}-1} [\lambda + u_0 + u_1(1+u_0)]^{-\left(\frac{a}{2} + \frac{v_0}{2} + \frac{v_1}{2}\right)} \quad (2.39)$$

$$= \lambda^{\frac{a}{2}} \sum_{b=0}^{\infty} \frac{\left(\frac{a}{2}\right)_b}{b!} (1-\lambda)^b \times \text{Beta}^{II}\left(\frac{v_0}{2}, \frac{a}{2} + b\right) \quad (2.40)$$

$$\times \text{Beta}^{II}\left(\frac{v_1}{2}, \frac{a}{2} + \sum_{k=0}^{j+m-1} \frac{v_0}{2} + b\right),$$

$$u_0, u_1 > 0.$$

**Remark 2.11** Other bivariate beta type II distributions that is defined on the positive domain will be briefly discussed. Let  $X$ ,  $W_0$  and  $W_1$  be independent chi-squared random variables with degrees of freedom  $a$ ,  $v_0$  and  $v_1$ , respectively. The bivariate  $F$  distribution is the joint distribution of

$$U_0 = \frac{aW_0}{v_0X}, \quad U_1 = \frac{aW_1}{v_1X}, \quad (2.41)$$

with pdf

$$f(u_0, u_1) = C u_0^{\frac{v_0}{2}-1} u_1^{\frac{v_1}{2}-1} \left(1 + \frac{v_0}{a} u_0 + \frac{v_1}{a} u_1\right)^{-\left(\frac{a}{2} + \frac{v_0}{2} + \frac{v_1}{2}\right)},$$

$$u_0, u_1 > 0,$$

where  $C = \frac{\Gamma(\frac{a}{2} + \frac{v_0}{2} + \frac{v_1}{2})}{\Gamma(\frac{a}{2}) \Gamma(\frac{v_0}{2}) \Gamma(\frac{v_1}{2})} a^{-\left(\frac{a}{2} + \frac{v_0}{2} + \frac{v_1}{2}\right)} a^{\frac{a}{2}} v_0^{\frac{v_0}{2}} v_1^{\frac{v_1}{2}}$  (see Balakrishnan and Lai, 2009 [4], p.367).

El-Bassiouny and Jones (2008) [10] explored the case if a further chi-squared random variable is added to the denominator of the second ratio in (2.41). This has the advantage that the marginal distributions do not share a common degree of freedom. To this end let  $W_2$  be a further chi-squared random variable, independent of  $X$ ,  $W_0$  and  $W_1$ , with  $v_2$  degrees of freedom. They proposed the extended bivariate  $F$  distribution as the joint distribution of

$$U_0 = \frac{aW_0}{v_0X}, \quad U_1 = \frac{(a + v_2)W_1}{v_1(X + W_2)},$$

## 2. GENERALISED MULTIVARIATE BETA TYPE II DISTRIBUTIONS

### 2.4. Marginal generalised beta type II distributions

with pdf

$$\begin{aligned}
 f(u_0, u_1) &= C u_0^{\frac{v_0}{2}-1} u_1^{\frac{v_1}{2}-1} \left( 1 + \frac{v_0}{a} u_0 + \frac{v_1}{(a+v_2)} u_1 \right)^{-\left(\frac{a}{2} + \frac{v_0}{2} + \frac{v_1}{2} + \frac{v_2}{2}\right)} \\
 &\times {}_2F_1 \left( \frac{a}{2} + \frac{v_0}{2} + \frac{v_1}{2} + \frac{v_2}{2}, \frac{v_2}{2}; \frac{a}{2} + \frac{v_0}{2} + \frac{v_2}{2}; \frac{\frac{v_0}{a} u_0}{1 + \frac{v_0}{a} u_0 + \frac{v_1}{(a+v_2)} u_1} \right), \\
 &u_0, u_1 > 0, \left| \frac{\frac{v_0}{a} u_0}{1 + \frac{v_0}{a} u_0 + \frac{v_1}{(a+v_2)} u_1} \right| < 1,
 \end{aligned}$$

$$\text{where } C = \frac{\Gamma\left(\frac{a}{2} + \frac{v_0}{2} + \frac{v_1}{2} + \frac{v_2}{2}\right) \Gamma\left(\frac{a}{2} + \frac{v_0}{2}\right)}{\Gamma\left(\frac{a}{2}\right) \Gamma\left(\frac{v_0}{2}\right) \Gamma\left(\frac{v_1}{2}\right) \Gamma\left(\frac{a}{2} + \frac{v_0}{2} + \frac{v_2}{2}\right)} \left(\frac{v_0}{a}\right)^{\frac{v_0}{2}} \left(\frac{v_1}{a+v_2}\right)^{\frac{v_1}{2}}.$$

The bivariate version of the generalised  $F$  distribution (2.16) proposed by Libby and Novick (1982) [27] is given by

$$\begin{aligned}
 f(u_0, u_1) &= \frac{\Gamma(a+v_0+v_1)}{\Gamma(a)\Gamma(v_0)\Gamma(v_1)} \left(\frac{\beta_a}{\beta_0}\right)^{v_0} u_0^{v_0-1} \left(\frac{\beta_a}{\beta_1}\right)^{v_1} u_1^{v_1-1} \\
 &\times \left( 1 + \frac{\beta_a}{\beta_0} u_0 + \frac{\beta_a}{\beta_1} u_1 \right)^{-(a+v_0+v_1)}, \\
 &u_0, u_1 > 0.
 \end{aligned} \tag{2.42}$$

From (2.39) and (2.42) it is evident that these distributions are different for the bivariate case.

### 2.4.3 Distribution of a subset

**Theorem 2.4** Let  $X, W_j$  with  $j = 0, 1, 2, \dots, p$  be independent chi-squared random variables with degrees of freedom  $a$  and  $v_j$  with  $j = 0, 1, 2, \dots, p$  respectively. Let  $U_0 = \frac{\lambda W_0}{X}$  and  $U_j = \frac{\lambda W_j}{X + \lambda \sum_{k=0}^{j-1} W_k}$  where  $j = 1, 2, \dots, p$  and  $\lambda > 0$ . If the joint pdf of  $U_0, U_1, \dots, U_p$  is given by (2.8), then the joint pdf of the subset  $U_r, U_{r+1}, \dots, U_p$  where  $r = 0, 1, \dots, p$  is given by

$$\begin{aligned}
 &f(u_r, u_{r+1}, \dots, u_p) \\
 &= \lambda^{\frac{a}{2}} \sum_{b=0}^{\infty} \frac{\left(\frac{a}{2}\right)_b}{b!} (1-\lambda)^b \prod_{j=r}^p \text{Beta}^{II} \left( \frac{v_j}{2}, \frac{a}{2} + \sum_{k=0}^{j-1} \frac{v_k}{2} + b \right)
 \end{aligned} \tag{2.43}$$

## 2. GENERALISED MULTIVARIATE BETA TYPE II DISTRIBUTIONS

### 2.4. Marginal generalised beta type II distributions

$$\begin{aligned}
&= \frac{\lambda^{\frac{a}{2}} \Gamma\left(\frac{a}{2} + \sum_{k=0}^p \frac{v_k}{2}\right)}{\prod_{j=r}^p \Gamma\left(\frac{v_j}{2}\right) \Gamma\left(\frac{a}{2} + \sum_{k=0}^{r-1} \frac{v_k}{2}\right)} \left( \prod_{j=r}^p u_j^{\frac{v_j}{2}-1} (1+u_j)^{-\left(\frac{a}{2} + \sum_{k=0}^j \frac{v_k}{2}\right)} \right) \\
&\times {}_2F_1\left(\frac{a}{2} + \sum_{k=0}^p \frac{v_k}{2}, \frac{a}{2}; \frac{a}{2} + \sum_{k=0}^{r-1} \frac{v_k}{2}; \frac{1-\lambda}{\prod_{j=r}^p (1+u_j)}\right) \\
&u_j > 0, j = r, \dots, p, \left| \frac{1-\lambda}{\prod_{j=r}^p (1+u_j)} \right| < 1.
\end{aligned} \tag{2.44}$$

**Proof.** The pdf of the subset  $(U_r, U_{r+1}, \dots, U_p)$  where  $r \leq p$  can be obtained by integrating the appropriate variables from the joint pdf in the form given in (2.23), similarly as in the proof of Theorem 2.3.

Therefore

$$\begin{aligned}
&f(u_r, u_{r+1}, \dots, u_p) \\
&= \int_0^\infty \dots \int_0^\infty \lambda^{\frac{a}{2}} \sum_{b=0}^\infty \frac{\left(\frac{a}{2}\right)_b}{b!} (1-\lambda)^b \prod_{j=0}^p \text{Beta}^{II}\left(\frac{v_j}{2}, \frac{a}{2} + \sum_{k=0}^{j-1} \frac{v_k}{2} + b\right) du_0 \dots du_{r-1} \\
&= \lambda^{\frac{a}{2}} \sum_{b=0}^\infty \frac{\left(\frac{a}{2}\right)_b}{b!} (1-\lambda)^b \prod_{j=r}^p \text{Beta}^{II}\left(\frac{v_j}{2}, \frac{a}{2} + \sum_{k=0}^{j-1} \frac{v_k}{2} + b\right).
\end{aligned}$$

The expression in (2.44) in terms of the Gauss hypergeometric function,  ${}_2F_1(\cdot)$ , follows from expanding the product of the beta type II pdfs (see (B.29)),

$$\begin{aligned}
&f(u_r, u_{r+1}, \dots, u_p) \\
&= \lambda^{\frac{a}{2}} \sum_{b=0}^\infty \frac{\left(\frac{a}{2}\right)_b}{b!} (1-\lambda)^b \prod_{j=r}^p \text{Beta}^{II}\left(\frac{v_j}{2}, \frac{a}{2} + \sum_{k=0}^{j-1} \frac{v_k}{2} + b\right) \\
&= \lambda^{\frac{a}{2}} \sum_{b=0}^\infty \frac{\left(\frac{a}{2}\right)_b}{b!} (1-\lambda)^b \\
&\quad \times \prod_{j=r}^p \left[ \frac{\Gamma\left(\frac{a}{2} + \sum_{k=0}^j \frac{v_k}{2} + b\right)}{\Gamma\left(\frac{v_j}{2}\right) \Gamma\left(\frac{a}{2} + \sum_{k=0}^{j-1} \frac{v_k}{2} + b\right)} u_j^{\frac{v_j}{2}-1} (1+u_j)^{-\left(\frac{a}{2} + \sum_{k=0}^j \frac{v_k}{2} + b\right)} \right] \\
&= \lambda^{\frac{a}{2}} \sum_{b=0}^\infty \frac{\left(\frac{a}{2}\right)_b}{b!} (1-\lambda)^b \frac{\Gamma\left(\frac{a}{2} + \sum_{k=0}^p \frac{v_k}{2} + b\right)}{\prod_{j=r}^p \Gamma\left(\frac{v_j}{2}\right) \Gamma\left(\frac{a}{2} + \sum_{k=0}^{r-1} \frac{v_k}{2} + b\right)} \\
&\quad \times \left( \prod_{j=r}^p u_j^{\frac{v_j}{2}-1} (1+u_j)^{-\left(\frac{a}{2} + \sum_{k=0}^j \frac{v_k}{2} + b\right)} \right).
\end{aligned} \tag{2.45}$$

## 2. GENERALISED MULTIVARIATE BETA TYPE II DISTRIBUTIONS

### 2.5. Product moments of the random variables

Note that

$$\begin{aligned}
 & \prod_{j=r}^p \left[ \frac{\Gamma\left(\frac{a}{2} + \sum_{k=0}^j \frac{v_k}{2} + b\right)}{\Gamma\left(\frac{a}{2} + \sum_{k=0}^{j-1} \frac{v_k}{2} + b\right)} \right] \\
 &= \frac{\Gamma\left(\frac{a}{2} + \sum_{k=0}^r \frac{v_k}{2} + b\right) \Gamma\left(\frac{a}{2} + \sum_{k=0}^{r+1} \frac{v_k}{2} + b\right) \dots \Gamma\left(\frac{a}{2} + \sum_{k=0}^p \frac{v_k}{2} + b\right)}{\Gamma\left(\frac{a}{2} + \sum_{k=0}^{r-1} \frac{v_k}{2} + b\right) \Gamma\left(\frac{a}{2} + \sum_{k=0}^r \frac{v_k}{2} + b\right) \dots \Gamma\left(\frac{a}{2} + \sum_{k=0}^{p-1} \frac{v_k}{2} + b\right)} \\
 &= \frac{\Gamma\left(\frac{a}{2} + \sum_{k=0}^p \frac{v_k}{2} + b\right)}{\Gamma\left(\frac{a}{2} + \sum_{k=0}^{r-1} \frac{v_k}{2} + b\right)}.
 \end{aligned}$$

Simplifying (2.45) using (B.4) and (B.10),

$$\begin{aligned}
 & f(u_r, u_{r+1}, \dots, u_p) \\
 &= \frac{\lambda^{\frac{a}{2}} \Gamma\left(\frac{a}{2} + \sum_{k=0}^p \frac{v_k}{2}\right)}{\prod_{j=r}^p \Gamma\left(\frac{v_j}{2}\right) \Gamma\left(\frac{a}{2} + \sum_{k=0}^{r-1} \frac{v_k}{2}\right)} \left( \prod_{j=r}^p u_j^{\frac{v_j}{2}-1} (1+u_j)^{-\left(\frac{a}{2} + \sum_{k=0}^j \frac{v_k}{2}\right)} \right) \\
 & \quad \times \sum_{b=0}^{\infty} \frac{\left(\frac{a}{2} + \sum_{k=0}^p \frac{v_k}{2}\right)_b \left(\frac{a}{2}\right)_b}{\left(\frac{a}{2} + \sum_{k=0}^{r-1} \frac{v_k}{2}\right)_b b!} \left( \frac{1-\lambda}{\prod_{j=r}^p (1+u_j)} \right)^b \\
 &= \frac{\lambda^{\frac{a}{2}} \Gamma\left(\frac{a}{2} + \sum_{k=0}^p \frac{v_k}{2}\right)}{\prod_{j=r}^p \Gamma\left(\frac{v_j}{2}\right) \Gamma\left(\frac{a}{2} + \sum_{k=0}^{r-1} \frac{v_k}{2}\right)} \left( \prod_{j=r}^p u_j^{\frac{v_j}{2}-1} (1+u_j)^{-\left(\frac{a}{2} + \sum_{k=0}^j \frac{v_k}{2}\right)} \right) \\
 & \quad \times {}_2F_1\left(\frac{a}{2} + \sum_{k=0}^p \frac{v_k}{2}, \frac{a}{2}; \frac{a}{2} + \sum_{k=0}^{r-1} \frac{v_k}{2}; \frac{1-\lambda}{\prod_{j=r}^p (1+u_j)}\right).
 \end{aligned}$$

■

## 2.5 Product moments of the random variables

In this section a general expression is derived for the product moments of the joint and bivariate distributions as well as for the distribution of a subset. Theorem 2.5 provides a derivation of the joint moments of  $U_0, U_1, \dots, U_p$ . The product moments for the bivariate case,  $E(U_j^r U_{j+m}^s)$  and a subset,  $E(U_r^{h_r} U_{r+1}^{h_{r+1}} \dots U_p^{h_p})$  are given in Theorem 2.6 and 2.7, respectively. The moments for the bivariate case will be used in Section 2.6 to investigate the correlation structure of this sequential process.

## 2. GENERALISED MULTIVARIATE BETA TYPE II DISTRIBUTIONS

### 2.5. Product moments of the random variables

**Theorem 2.5** *The joint moments of  $U_0, U_1, \dots, U_p$ , where  $U_0, U_1, \dots, U_p$  has joint pdf (2.8), is given by*

$$E \left( U_0^{h_0} U_1^{h_1} \dots U_p^{h_p} \right) = \frac{\lambda^{\frac{a}{2}} \Gamma \left( \frac{a}{2} + \sum_{k=0}^p \frac{v_k}{2} \right)}{\Gamma \left( \frac{a}{2} \right) \prod_{k=0}^p \Gamma \left( \frac{v_k}{2} \right)} \sum_{b=0}^{\infty} \frac{\left( \frac{a}{2} + \sum_{k=0}^p \frac{v_k}{2} \right)_b}{b!} (1 - \lambda)^b \quad (2.46)$$

$$\times \prod_{j=0}^p \frac{\Gamma \left( \frac{v_j}{2} + h_j \right) \Gamma \left( \frac{a}{2} + \sum_{k=0}^{j-1} \frac{v_k}{2} + b - h_j \right)}{\Gamma \left( \frac{a}{2} + \sum_{k=0}^j \frac{v_k}{2} + b \right)},$$

with the values of the parameters such that  $E \left( U_0^{h_0} U_1^{h_1} \dots U_p^{h_p} \right)$  is defined.

Take note that  $\sum_{k=0}^{j-1} \frac{v_k}{2} = 0$  if  $j < 1$ .

**Proof.** The joint moments of  $U_0, U_1, \dots, U_p$ , using the joint pdf in the form given in (2.19) and expanding  ${}_1F_0(\cdot)$  in series form (see (B.7)), is defined as

$$E \left( U_0^{h_0} U_1^{h_1} \dots U_p^{h_p} \right)$$

$$= \frac{\lambda^{\frac{a}{2}} \Gamma \left( \frac{a}{2} + \sum_{k=0}^p \frac{v_k}{2} \right)}{\Gamma \left( \frac{a}{2} \right) \prod_{k=0}^p \Gamma \left( \frac{v_k}{2} \right)} \int_0^{\infty} \dots \int_0^{\infty} \left( \prod_{j=0}^p u_j^{\frac{v_j}{2} + h_j - 1} \right) \left( \prod_{j=0}^p (1 + u_j)^{-\left( \frac{a}{2} + \sum_{k=0}^j \frac{v_k}{2} \right)} \right)$$

$$\times \sum_{b=0}^{\infty} \frac{\left( \frac{a}{2} + \sum_{k=0}^p \frac{v_k}{2} \right)_b}{b!} \left[ \frac{1 - \lambda}{\prod_{j=0}^p (1 + u_j)} \right]^b du_0 \dots du_p.$$

Rearranging the terms in the above expression give

$$E \left( U_0^{h_0} U_1^{h_1} \dots U_p^{h_p} \right) = \frac{\lambda^{\frac{a}{2}} \Gamma \left( \frac{a}{2} + \sum_{k=0}^p \frac{v_k}{2} \right)}{\Gamma \left( \frac{a}{2} \right) \prod_{k=0}^p \Gamma \left( \frac{v_k}{2} \right)} \sum_{b=0}^{\infty} \frac{\left( \frac{a}{2} + \sum_{k=0}^p \frac{v_k}{2} \right)_b}{b!} (1 - \lambda)^b$$

$$\times \prod_{j=0}^p \left( \int_0^{\infty} u_j^{\frac{v_j}{2} + h_j - 1} (1 + u_j)^{-\left( \frac{a}{2} + \sum_{k=0}^j \frac{v_k}{2} + b \right)} du_j \right).$$

Evaluation of the above integrals using (B.2), yields the desired expression (2.46). ■



## 2. GENERALISED MULTIVARIATE BETA TYPE II DISTRIBUTIONS

### 2.5. Product moments of the random variables

**Theorem 2.6** *The product moment of  $U_j, U_{j+m}$ , where  $U_j, U_{j+m}$  has the bivariate pdf (2.35), is given by*

$$\begin{aligned}
 E(U_j^r U_{j+m}^s) &= \frac{\lambda^{\frac{a}{2}} \Gamma\left(\frac{v_j}{2} + r\right) \Gamma\left(\frac{v_{j+m}}{2} + s\right) \Gamma\left(\frac{a}{2} + \sum_{k=0}^{j-1} \frac{v_k}{2} - r\right) \Gamma\left(\frac{a}{2} + \sum_{k=0}^{j+m-1} \frac{v_k}{2} - s\right)}{\Gamma\left(\frac{v_j}{2}\right) \Gamma\left(\frac{a}{2} + \sum_{k=0}^{j-1} \frac{v_k}{2}\right) \Gamma\left(\frac{v_{j+m}}{2}\right) \Gamma\left(\frac{a}{2} + \sum_{k=0}^{j+m-1} \frac{v_k}{2}\right)} \\
 &\quad \times {}_3F_2\left(\frac{a}{2} + \sum_{k=0}^{j-1} \frac{v_k}{2} - r, \frac{a}{2} + \sum_{k=0}^{j+m-1} \frac{v_k}{2} - s, \frac{a}{2}; \frac{a}{2} + \sum_{k=0}^{j+m-1} \frac{v_k}{2}, \frac{a}{2} + \sum_{k=0}^{j-1} \frac{v_k}{2}; 1 - \lambda\right), \\
 &\quad |1 - \lambda| < 1,
 \end{aligned} \tag{2.47}$$

where  $j = 0, 1, 2, \dots, p$  and  $m = 1, 2, 3, \dots$

**Proof.** The product moment of  $U_j, U_{j+m}$ , using the bivariate pdf in the form given in (2.35) and expanding the hypergeometric function  ${}_3F_2(\cdot)$  in series form (see (B.5)), is defined as

$$\begin{aligned}
 E(U_j^r U_{j+m}^s) &= \frac{\Gamma\left(\frac{a}{2} + \sum_{k=0}^j \frac{v_k}{2}\right) \Gamma\left(\frac{a}{2} + \sum_{k=0}^{j+m} \frac{v_k}{2}\right) \lambda^{\frac{a}{2}}}{\Gamma\left(\frac{v_j}{2}\right) \Gamma\left(\frac{a}{2} + \sum_{k=0}^{j-1} \frac{v_k}{2}\right) \Gamma\left(\frac{v_{j+m}}{2}\right) \Gamma\left(\frac{a}{2} + \sum_{k=0}^{j+m-1} \frac{v_k}{2}\right)} \\
 &\quad \times \int_0^\infty \int_0^\infty u_j^{\frac{v_j}{2} + r - 1} (1 + u_j)^{-\left(\frac{a}{2} + \sum_{k=0}^j \frac{v_k}{2}\right)} u_{j+m}^{\frac{v_{j+m}}{2} + s - 1} (1 + u_{j+m})^{-\left(\frac{a}{2} + \sum_{k=0}^{j+m} \frac{v_k}{2}\right)} \\
 &\quad \times \sum_{b=0}^\infty \frac{\left(\frac{a}{2} + \sum_{k=0}^{j+m} \frac{v_k}{2}\right)_b \left(\frac{a}{2} + \sum_{k=0}^j \frac{v_k}{2}\right)_b \left(\frac{a}{2}\right)_b}{\left(\frac{a}{2} + \sum_{k=0}^{j+m-1} \frac{v_k}{2}\right)_b \left(\frac{a}{2} + \sum_{k=0}^{j-1} \frac{v_k}{2}\right)_b b!} \left[\frac{1 - \lambda}{(1 + u_j)(1 + u_{j+m})}\right]^b du_{j+m} du_j.
 \end{aligned}$$

Rearranging the terms in the above expression give

$$\begin{aligned}
 E(U_j^r U_{j+m}^s) &= \frac{\Gamma\left(\frac{a}{2} + \sum_{k=0}^j \frac{v_k}{2}\right) \Gamma\left(\frac{a}{2} + \sum_{k=0}^{j+m} \frac{v_k}{2}\right) \lambda^{\frac{a}{2}}}{\Gamma\left(\frac{v_j}{2}\right) \Gamma\left(\frac{a}{2} + \sum_{k=0}^{j-1} \frac{v_k}{2}\right) \Gamma\left(\frac{v_{j+m}}{2}\right) \Gamma\left(\frac{a}{2} + \sum_{k=0}^{j+m-1} \frac{v_k}{2}\right)} \\
 &\quad \times \sum_{b=0}^\infty \frac{\left(\frac{a}{2} + \sum_{k=0}^{j+m} \frac{v_k}{2}\right)_b \left(\frac{a}{2} + \sum_{k=0}^j \frac{v_k}{2}\right)_b \left(\frac{a}{2}\right)_b}{\left(\frac{a}{2} + \sum_{k=0}^{j+m-1} \frac{v_k}{2}\right)_b \left(\frac{a}{2} + \sum_{k=0}^{j-1} \frac{v_k}{2}\right)_b b!} (1 - \lambda)^b \\
 &\quad \times \int_0^\infty u_j^{\frac{v_j}{2} + r - 1} (1 + u_j)^{-\left(\frac{a}{2} + \sum_{k=0}^j \frac{v_k}{2} + b\right)} du_j \int_0^\infty u_{j+m}^{\frac{v_{j+m}}{2} + s - 1} (1 + u_{j+m})^{-\left(\frac{a}{2} + \sum_{k=0}^{j+m} \frac{v_k}{2} + b\right)} du_{j+m}.
 \end{aligned}$$

## 2. GENERALISED MULTIVARIATE BETA TYPE II DISTRIBUTIONS

### 2.5. Product moments of the random variables

Evaluation of the above integrals using (B.2), and simplifying yields the desired result (2.47),

$$\begin{aligned}
& E(U_j^r U_{j+m}^s) \\
&= \frac{\Gamma\left(\frac{a}{2} + \sum_{k=0}^j \frac{v_k}{2}\right) \Gamma\left(\frac{a}{2} + \sum_{k=0}^{j+m} \frac{v_k}{2}\right) \lambda^{\frac{a}{2}}}{\Gamma\left(\frac{v_j}{2}\right) \Gamma\left(\frac{a}{2} + \sum_{k=0}^{j-1} \frac{v_k}{2}\right) \Gamma\left(\frac{v_{j+m}}{2}\right) \Gamma\left(\frac{a}{2} + \sum_{k=0}^{j+m-1} \frac{v_k}{2}\right)} \\
&\quad \times \sum_{b=0}^{\infty} \frac{\left(\frac{a}{2} + \sum_{k=0}^{j+m} \frac{v_k}{2}\right)_b \left(\frac{a}{2} + \sum_{k=0}^j \frac{v_k}{2}\right)_b \left(\frac{a}{2}\right)_b}{\left(\frac{a}{2} + \sum_{k=0}^{j+m-1} \frac{v_k}{2}\right)_b \left(\frac{a}{2} + \sum_{k=0}^{j-1} \frac{v_k}{2}\right)_b} (1-\lambda)^b \\
&\quad \times \frac{\Gamma\left(\frac{v_j}{2} + r\right) \Gamma\left(\frac{a}{2} + \sum_{k=0}^{j-1} \frac{v_k}{2} + b - r\right) \Gamma\left(\frac{v_{j+m}}{2} + s\right) \Gamma\left(\frac{a}{2} + \sum_{k=0}^{j+m-1} \frac{v_k}{2} + b - s\right)}{\Gamma\left(\frac{a}{2} + \sum_{k=0}^j \frac{v_k}{2} + b\right) \Gamma\left(\frac{a}{2} + \sum_{k=0}^{j+m} \frac{v_k}{2} + b\right)} \\
&= \frac{\Gamma\left(\frac{a}{2} + \sum_{k=0}^j \frac{v_k}{2}\right) \Gamma\left(\frac{a}{2} + \sum_{k=0}^{j+m} \frac{v_k}{2}\right) \lambda^{\frac{a}{2}}}{\Gamma\left(\frac{v_j}{2}\right) \Gamma\left(\frac{a}{2} + \sum_{k=0}^{j-1} \frac{v_k}{2}\right) \Gamma\left(\frac{v_{j+m}}{2}\right) \Gamma\left(\frac{a}{2} + \sum_{k=0}^{j+m-1} \frac{v_k}{2}\right)} \\
&\quad \times \sum_{b=0}^{\infty} \frac{\Gamma\left(\frac{a}{2} + \sum_{k=0}^{j+m} \frac{v_k}{2} + b\right) \Gamma\left(\frac{a}{2} + \sum_{k=0}^j \frac{v_k}{2} + b\right) \Gamma\left(\frac{a}{2} + b\right) \Gamma\left(\frac{a}{2} + \sum_{k=0}^{j+m-1} \frac{v_k}{2}\right)}{\Gamma\left(\frac{a}{2} + \sum_{k=0}^{j+m} \frac{v_k}{2}\right) \Gamma\left(\frac{a}{2} + \sum_{k=0}^j \frac{v_k}{2}\right) \Gamma\left(\frac{a}{2}\right) \Gamma\left(\frac{a}{2} + \sum_{k=0}^{j+m-1} \frac{v_k}{2} + b\right)} b! \\
&\quad \times \frac{\Gamma\left(\frac{a}{2} + \sum_{k=0}^{j-1} \frac{v_k}{2}\right)}{\Gamma\left(\frac{a}{2} + \sum_{k=0}^{j-1} \frac{v_k}{2} + b\right)} (1-\lambda)^b \frac{\Gamma\left(\frac{v_j}{2} + r\right) \Gamma\left(\frac{a}{2} + \sum_{k=0}^{j-1} \frac{v_k}{2} + b - r\right)}{\Gamma\left(\frac{a}{2} + \sum_{k=0}^j \frac{v_k}{2} + b\right)} \\
&\quad \times \frac{\Gamma\left(\frac{v_{j+m}}{2} + s\right) \Gamma\left(\frac{a}{2} + \sum_{k=0}^{j+m-1} \frac{v_k}{2} + b - s\right)}{\Gamma\left(\frac{a}{2} + \sum_{k=0}^{j+m} \frac{v_k}{2} + b\right)} \\
&= \frac{\lambda^{\frac{a}{2}} \Gamma\left(\frac{v_j}{2} + r\right) \Gamma\left(\frac{v_{j+m}}{2} + s\right) \Gamma\left(\frac{a}{2} + \sum_{k=0}^{j-1} \frac{v_k}{2} - r\right) \Gamma\left(\frac{a}{2} + \sum_{k=0}^{j+m-1} \frac{v_k}{2} - s\right)}{\Gamma\left(\frac{v_j}{2}\right) \Gamma\left(\frac{a}{2} + \sum_{k=0}^{j-1} \frac{v_k}{2}\right) \Gamma\left(\frac{v_{j+m}}{2}\right) \Gamma\left(\frac{a}{2} + \sum_{k=0}^{j+m-1} \frac{v_k}{2}\right)} \\
&\quad \times \sum_{b=0}^{\infty} \frac{\Gamma\left(\frac{a}{2} + b\right) \Gamma\left(\frac{a}{2} + \sum_{k=0}^{j+m-1} \frac{v_k}{2}\right) \Gamma\left(\frac{a}{2} + \sum_{k=0}^{j-1} \frac{v_k}{2}\right)}{\Gamma\left(\frac{a}{2}\right) \Gamma\left(\frac{a}{2} + \sum_{k=0}^{j+m-1} \frac{v_k}{2} + b\right) \Gamma\left(\frac{a}{2} + \sum_{k=0}^{j-1} \frac{v_k}{2} + b\right)} \\
&\quad \times \frac{\Gamma\left(\frac{a}{2} + \sum_{k=0}^{j-1} \frac{v_k}{2} + b - r\right) \Gamma\left(\frac{a}{2} + \sum_{k=0}^{j+m-1} \frac{v_k}{2} + b - s\right)}{\Gamma\left(\frac{a}{2} + \sum_{k=0}^{j-1} \frac{v_k}{2} - r\right) \Gamma\left(\frac{a}{2} + \sum_{k=0}^{j+m-1} \frac{v_k}{2} - s\right)} b! (1-\lambda)^b.
\end{aligned}$$

■

## 2. GENERALISED MULTIVARIATE BETA TYPE II DISTRIBUTIONS

### 2.5. Product moments of the random variables

**Remark 2.12** *In the following three remarks the cases  $j = 0$  and / or  $m = 1$  in expression (2.47) is considered respectively, since the correlation is plotted for these cases in Section 2.6.*

(i) If  $j = 0$ ,

$$\begin{aligned}
 E(U_0^r U_m^s) &= \frac{\lambda^{\frac{a}{2}} \Gamma\left(\frac{v_0}{2} + r\right) \Gamma\left(\frac{v_m}{2} + s\right) \Gamma\left(\frac{a}{2} - r\right) \Gamma\left(\frac{a}{2} + \sum_{k=0}^{m-1} \frac{v_k}{2} - s\right)}{\Gamma\left(\frac{v_0}{2}\right) \Gamma\left(\frac{a}{2}\right) \Gamma\left(\frac{v_m}{2}\right) \Gamma\left(\frac{a}{2} + \sum_{k=0}^{m-1} \frac{v_k}{2}\right)} \\
 &\quad \times {}_2F_1\left(\frac{a}{2} - r, \frac{a}{2} + \sum_{k=0}^{m-1} \frac{v_k}{2} - s; \frac{a}{2} + \sum_{k=0}^{m-1} \frac{v_k}{2}; 1 - \lambda\right), \\
 &\qquad\qquad\qquad |1 - \lambda| < 1.
 \end{aligned} \tag{2.48}$$

Take note that  $\sum_{k=0}^{j-1} \frac{v_k}{2} = 0$  if  $j < 1$ .

(ii) If  $m = 1$ ,

$$\begin{aligned}
 E(U_j^r U_{j+1}^s) &= \frac{\lambda^{\frac{a}{2}} \Gamma\left(\frac{v_j}{2} + r\right) \Gamma\left(\frac{v_{j+1}}{2} + s\right) \Gamma\left(\frac{a}{2} + \sum_{k=0}^{j-1} \frac{v_k}{2} - r\right) \Gamma\left(\frac{a}{2} + \sum_{k=0}^j \frac{v_k}{2} - s\right)}{\Gamma\left(\frac{v_j}{2}\right) \Gamma\left(\frac{a}{2} + \sum_{k=0}^{j-1} \frac{v_k}{2}\right) \Gamma\left(\frac{v_{j+1}}{2}\right) \Gamma\left(\frac{a}{2} + \sum_{k=0}^j \frac{v_k}{2}\right)} \\
 &\quad \times {}_3F_2\left(\frac{a}{2} + \sum_{k=0}^{j-1} \frac{v_k}{2} - r, \frac{a}{2} + \sum_{k=0}^j \frac{v_k}{2} - s, \frac{a}{2}; \frac{a}{2} + \sum_{k=0}^j \frac{v_k}{2}, \frac{a}{2} + \sum_{k=0}^{j-1} \frac{v_k}{2}; 1 - \lambda\right), \\
 &\qquad\qquad\qquad |1 - \lambda| < 1.
 \end{aligned} \tag{2.49}$$

(iii) If  $j = 0, m = 1$

$$\begin{aligned}
 E(U_0^r U_1^s) &= \frac{\lambda^{\frac{a}{2}} \Gamma\left(\frac{v_0}{2} + r\right) \Gamma\left(\frac{v_1}{2} + s\right) \Gamma\left(\frac{a}{2} - r\right) \Gamma\left(\frac{a}{2} + \frac{v_0}{2} - s\right)}{\Gamma\left(\frac{v_0}{2}\right) \Gamma\left(\frac{a}{2}\right) \Gamma\left(\frac{v_1}{2}\right) \Gamma\left(\frac{a}{2} + \frac{v_0}{2}\right)} \\
 &\quad \times {}_2F_1\left(\frac{a}{2} - r, \frac{a}{2} + \frac{v_0}{2} - s; \frac{a}{2} + \frac{v_0}{2}; 1 - \lambda\right), \\
 &\qquad\qquad\qquad |1 - \lambda| < 1.
 \end{aligned} \tag{2.50}$$

## 2. GENERALISED MULTIVARIATE BETA TYPE II DISTRIBUTIONS

### 2.6. Shape analysis and correlation

**Theorem 2.7** *The joint moments of a subset  $U_r, U_{r+1}, \dots, U_p$  where  $r = 0, 1, \dots, p$  with joint pdf (2.44), is given by*

$$\begin{aligned}
 & E \left( U_r^{h_r} \dots U_p^{h_p} \right) \\
 &= \frac{\lambda^{\frac{a}{2}} \Gamma \left( \frac{a}{2} + \sum_{k=0}^p \frac{v_k}{2} \right)}{\Gamma \left( \frac{a}{2} + \sum_{k=0}^{r-1} \frac{v_k}{2} \right) \prod_{k=r}^p \Gamma \left( \frac{v_k}{2} \right)} \sum_{b=0}^{\infty} \frac{\left( \frac{a}{2} + \sum_{k=0}^p \frac{v_k}{2} \right)_b \left( \frac{a}{2} \right)_b}{\left( \frac{a}{2} + \sum_{k=0}^{r-1} \frac{v_k}{2} \right)_b b!} (1 - \lambda)^b \\
 & \quad \times \prod_{j=r}^p \frac{\Gamma \left( \frac{v_j}{2} + h_j \right) \Gamma \left( \frac{a}{2} + \sum_{k=0}^{j-1} \frac{v_k}{2} + b - h_j \right)}{\Gamma \left( \frac{a}{2} + \sum_{k=0}^j \frac{v_k}{2} + b \right)}, \tag{2.51}
 \end{aligned}$$

with the values of the parameters such that  $E \left( U_r^{h_r} \dots U_p^{h_p} \right)$  is defined.

**Proof.** Using the pdf of a subset given in (2.44) and expanding the hypergeometric function  ${}_2F_1(\cdot)$  (see (B.10)),

$$\begin{aligned}
 & E \left( U_r^{h_r} \dots U_p^{h_p} \right) \\
 &= \frac{\lambda^{\frac{a}{2}} \Gamma \left( \frac{a}{2} + \sum_{k=0}^p \frac{v_k}{2} \right)}{\Gamma \left( \frac{a}{2} + \sum_{k=0}^{r-1} \frac{v_k}{2} \right) \prod_{j=r}^p \Gamma \left( \frac{v_j}{2} \right)} \int_0^{\infty} \dots \int_0^{\infty} \left( \prod_{j=r}^p u_j^{\frac{v_j}{2} + h_j - 1} (1 + u_j)^{-\left( \frac{a}{2} + \sum_{k=0}^j \frac{v_k}{2} \right)} \right) \\
 & \quad \times \sum_{b=0}^{\infty} \frac{\left( \frac{a}{2} + \sum_{k=0}^p \frac{v_k}{2} \right)_b \left( \frac{a}{2} \right)_b}{\left( \frac{a}{2} + \sum_{k=0}^{r-1} \frac{v_k}{2} \right)_b b!} \left[ \frac{1 - \lambda}{\prod_{j=r}^p (1 + u_j)} \right]^b du_r \dots du_p \\
 &= \frac{\lambda^{\frac{a}{2}} \Gamma \left( \frac{a}{2} + \sum_{k=0}^p \frac{v_k}{2} \right)}{\Gamma \left( \frac{a}{2} + \sum_{k=0}^{r-1} \frac{v_k}{2} \right) \prod_{j=r}^p \Gamma \left( \frac{v_j}{2} \right)} \sum_{b=0}^{\infty} \frac{\left( \frac{a}{2} + \sum_{k=0}^p \frac{v_k}{2} \right)_b \left( \frac{a}{2} \right)_b}{\left( \frac{a}{2} + \sum_{k=0}^{r-1} \frac{v_k}{2} \right)_b b!} (1 - \lambda)^b \\
 & \quad \times \int_0^{\infty} \dots \int_0^{\infty} \left( \prod_{j=r}^p u_j^{\frac{v_j}{2} + h_j - 1} (1 + u_j)^{-\left( \frac{a}{2} + \sum_{k=0}^j \frac{v_k}{2} + b \right)} \right) du_r \dots du_p \\
 &= \frac{\lambda^{\frac{a}{2}} \Gamma \left( \frac{a}{2} + \sum_{k=0}^p \frac{v_k}{2} \right)}{\Gamma \left( \frac{a}{2} + \sum_{k=0}^{r-1} \frac{v_k}{2} \right) \prod_{j=r}^p \Gamma \left( \frac{v_j}{2} \right)} \sum_{b=0}^{\infty} \frac{\left( \frac{a}{2} + \sum_{k=0}^p \frac{v_k}{2} \right)_b \left( \frac{a}{2} \right)_b}{\left( \frac{a}{2} + \sum_{k=0}^{r-1} \frac{v_k}{2} \right)_b b!} (1 - \lambda)^b \\
 & \quad \times \prod_{j=r}^p \left( \int_0^{\infty} u_j^{\frac{v_j}{2} + h_j - 1} (1 + u_j)^{-\left( \frac{a}{2} + \sum_{k=0}^j \frac{v_k}{2} + b \right)} du_j \right).
 \end{aligned}$$

Evaluation of the above integrals using (B.2), yields the desired expression (2.51). ■

## 2.6 Shape analysis and correlation

In this section the shape of the univariate and bivariate marginal pdfs of the generalised multivariate beta type II distribution will be illustrated for different values of the para-

## 2. GENERALISED MULTIVARIATE BETA TYPE II DISTRIBUTIONS

### 2.6. Shape analysis and correlation

---

parameters  $\lambda$ ,  $a$  and  $v_j$ . The effect of the different parameters on the correlation between  $U_j$  and  $U_{j+m}$  will also be investigated.

In terms of the process control application the parameters can be interpreted as follows:

- $\lambda$  : size of the unknown shift in the variance,
- $a$  : pooled number of observations before the shift in the unknown variance took place,
- $v_j$  : sample size at time period  $\kappa + j$ ,
- $\kappa$  : the first time period following the shift in the unknown variance.

Take note that in this section it will be assumed that the sample sizes at each point in time are equal, in effect  $v_j = v = n$  and therefore  $a = \sum_{i=1}^{\kappa-1} n = (\kappa - 1) \times n$ .

Figure 2.2 illustrates the effect of the parameters  $\lambda$ ,  $a$  and  $v$  on the univariate pdf (see (2.24), (2.25)). The software package Mathematica was used to draw graphs. In all four panels, the solid black line ( $\lambda = 1.5$ ,  $v = 5$  and  $a = 20$ ) is the same and is used as reference in order to easily make comparisons between the panels. In terms of the SPC application this reference case represents monitoring a process where the variance changed with a factor of 1.5 (i.e.  $\lambda = \frac{\sigma_1^2}{\sigma_0^2} = 1.5$ ) between samples four and five (i.e.  $\kappa = 5$ ) using samples of size five (i.e.  $v = n = 5$  and  $a = (\kappa - 1) \times n = 20$ ). Panels (i) to (iii) focus on the random variable  $U_0$ . In panel (i) the role of  $\lambda$  is investigated. Take note that when  $\lambda = 1$ , the pdf simplifies to that of a beta type II pdf (see Remark 2.7). Panel (ii) shows that for larger values of  $a$  (meaning the shift took place after a long time) the plot moves towards the vertical axis. Take note that  $a$  depends on the sample size at each point in time as well as  $\kappa$ , the sample from which the process parameter has changed. Panel (iii) examines the effect of the  $v = n$ . Note that for the special case when individual samples are considered (i.e. when  $v = n = 1$ ), the shape is different. In panel (iv), the influence of  $j$  is investigated, where  $j$  represents the position of the random variable in the process. For larger values of  $j$  the pdf moves towards the vertical axis.

## 2. GENERALISED MULTIVARIATE BETA TYPE II DISTRIBUTIONS

### 2.6. Shape analysis and correlation

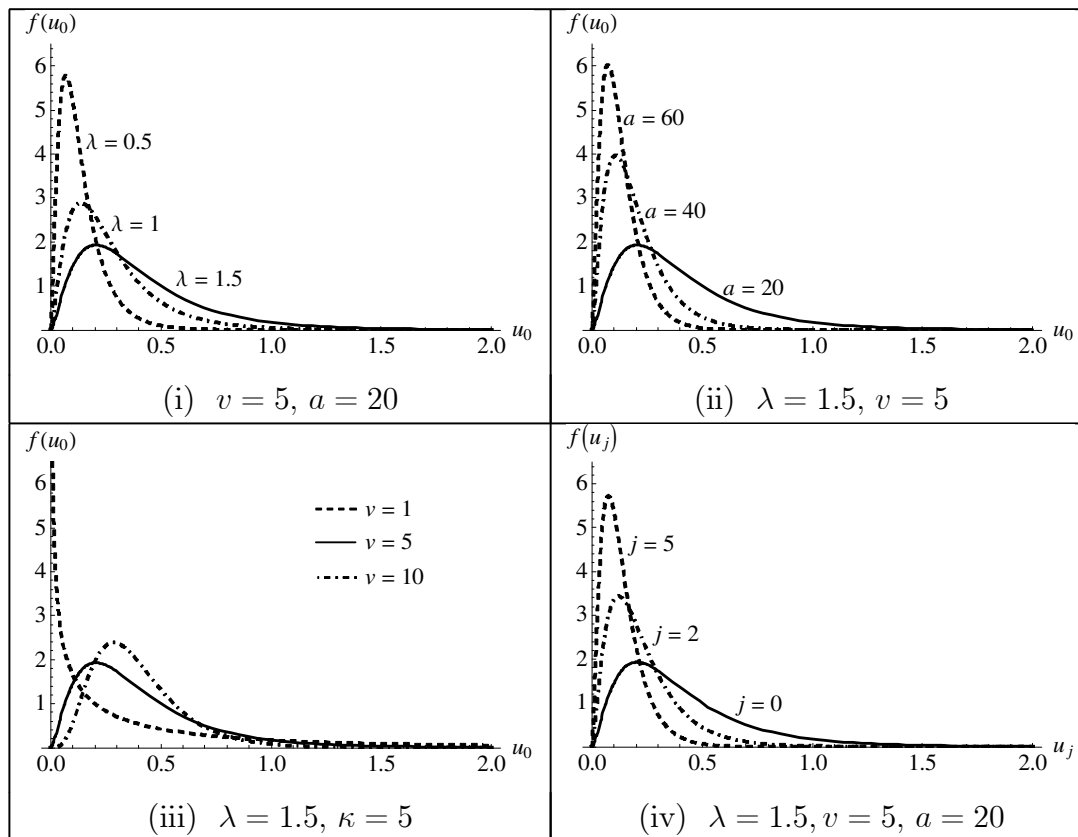
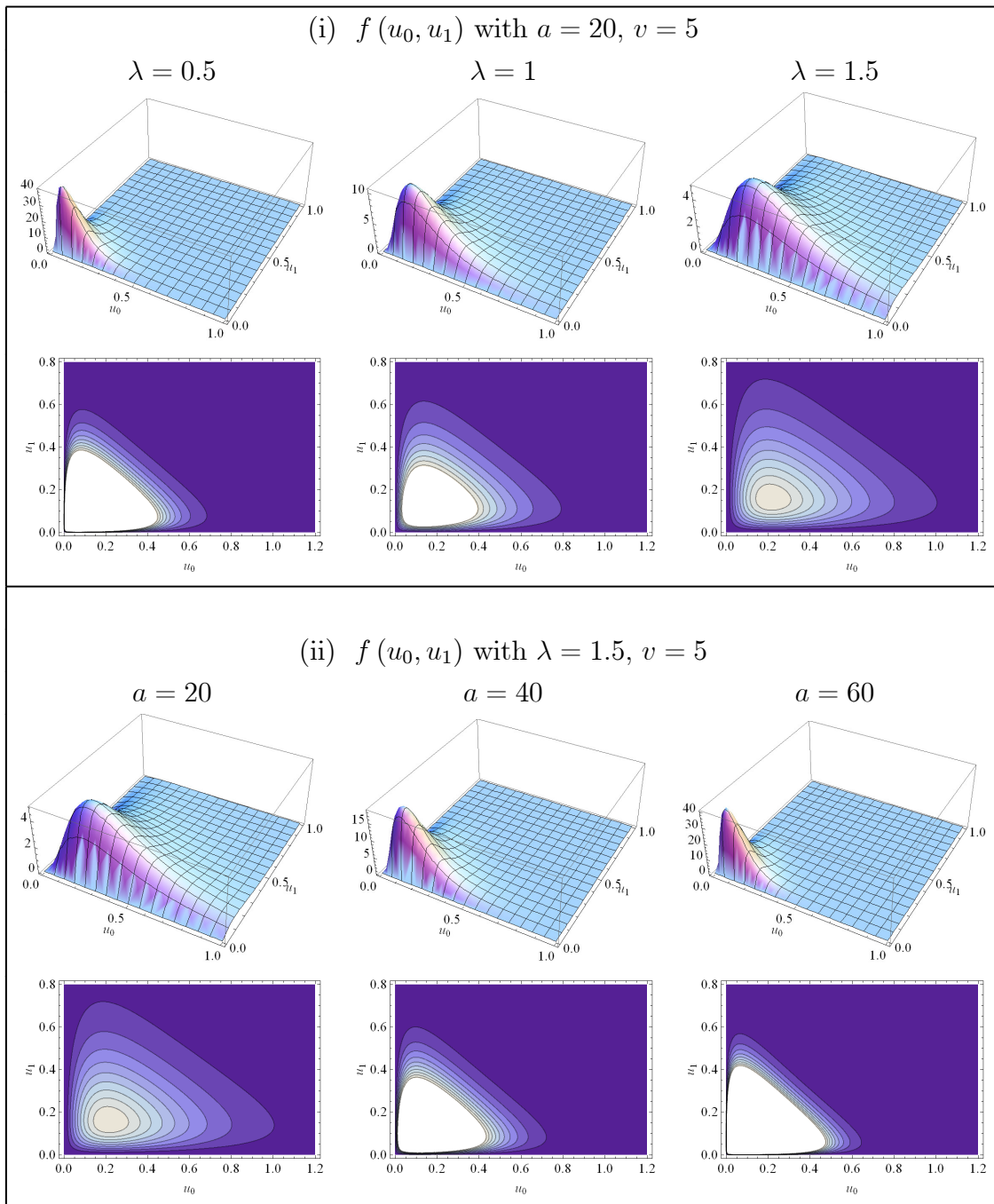

**Figure 2.2** The marginal pdfs (2.24) and (2.25) for different values of the parameters  $\lambda$ ,  $a$  and  $v$

Figures 2.3 and 2.4 plot the bivariate pdf (see (2.35), (2.36), (2.37), (2.39)) for different values of the parameters  $\lambda$ ,  $a$  and  $v$ . In each panel the reference case ( $\lambda = 1.5$ ,  $v = 5$ ,  $a = 20$ ) will be included for easy comparison between the panels. Panels (i) to (iii) consider the two consecutive random variables  $U_0$  and  $U_1$ , while Figure 2.4 illustrates the bivariate pdf for consecutive random variables further along in the process (for example  $(U_1, U_2)$ ) and random variables that are not consecutively observed (for example  $(U_0, U_3)$ ). Panel (i) shows the effect of  $\lambda$ . For  $\lambda < 1$  there was a downward shift in the process parameter, while for  $\lambda > 1$  an upward shift occurred. The role of  $a$  is investigated in panel (ii), where  $a$  has to do with when the shift took place. For bigger values of  $a$ , the process was longer in-control. Panel (iii) examines the effect of  $v$ . Note that for  $v = 1$  the shape is different. A similar behaviour was observed in the marginal case (see Figure 2.2 (iii)). Since the pdf has an asymptote at  $u_0 = u_1 = 0$  a truncated version of the joint pdf is also included to get a better idea of the shape close to zero.

## 2. GENERALISED MULTIVARIATE BETA TYPE II DISTRIBUTIONS

### 2.6. Shape analysis and correlation



**Figure 2.3** The bivariate pdf of  $(U_0, U_1)$  (see (2.39)) for different values of the parameters  $\lambda, a$  and  $v$

## 2. GENERALISED MULTIVARIATE BETA TYPE II DISTRIBUTIONS

### 2.6. Shape analysis and correlation

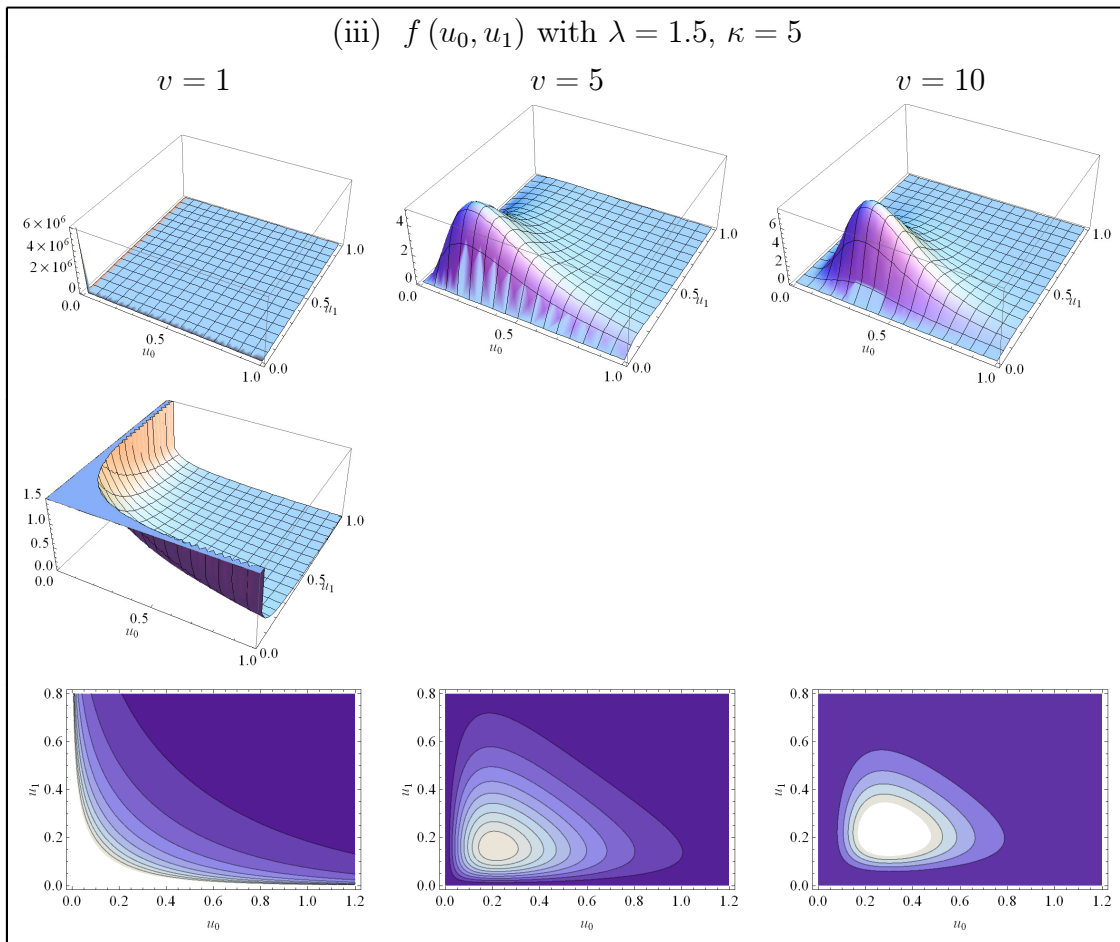

**Figure 2.3** The bivariate pdf of  $(U_0, U_1)$  (see (2.39)) for different values of the parameters  $\lambda, a$  and  $v$

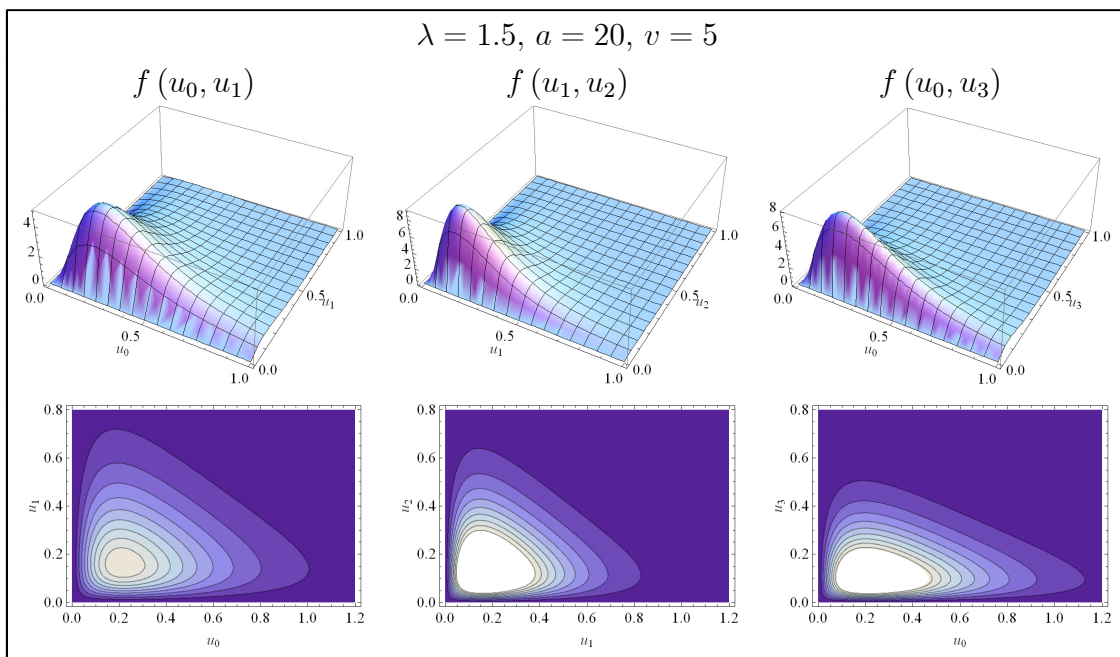

**Figure 2.4** The bivariate pdf of  $(U_0, U_1)$ ,  $(U_1, U_2)$  and  $(U_0, U_3)$  (see (2.39), (2.36) and (2.37), respectively) for  $\lambda = 1.5$ ,  $a = 20$  and  $v = 5$



## 2. GENERALISED MULTIVARIATE BETA TYPE II DISTRIBUTIONS

### 2.6. Shape analysis and correlation

Substituting the appropriate values for  $r$  and  $s$  in (2.47) (see also (2.48), (2.49) and (2.50)) the correlation between  $U_j$  and  $U_{j+m}$  can be calculated. Take note that  $j$  represents the number of samples after the change in the parameter value and  $m$  indicates how far apart the two random variables are. The software package Mathematica was used to compute these correlations. In Figure 2.5 panel (i) the correlation is plotted as a function of  $\lambda$  for  $j = 0, m = 1, v = 5$  and  $a = 20$ . In other words, the correlation between  $U_0$  and  $U_1$  when monitoring a process where the variance changed between samples four and five (i.e.  $\kappa = 5$ ) using samples of size five (i.e.  $v = 5$  and  $a = (\kappa - 1) \times v = 20$ ). The shape will be similar for other values of the parameters  $j, m, a$  and  $v$ . The sign of the correlation depends on the value of  $\lambda$ , for  $\lambda < 1$  (downwards shift in the process parameter) the correlation is positive while for values of  $\lambda > 1$  (upwards shift) the correlation is negative. For  $\lambda = 1$  (i.e. the process is in-control), the random variables  $U_j$  and  $U_{j+m}$ ,  $m > 0$ , are uncorrelated. Panels (ii) to (v) investigate the influence of the other parameters on the correlation for the cases where  $\lambda = 0.5$  and  $\lambda = 1.5$ . Panel (ii) plots the correlation between consecutive observations since  $m = 1$ . For larger values of  $j$  (long time after the change in the parameter took place) the correlation gets very small in absolute terms. Panel (iii) shows that the further apart the two random variables are, the smaller the correlation in absolute terms. Panel (iv) looks at the influence of  $\kappa$ , the sample number when the variance parameter changed. From  $\kappa = 1$  to  $\kappa = 2$  the correlation initially increases in absolute terms and from  $\kappa \geq 2$  the correlation slowly decreases. The shape of the plot suggests that the correlation will be zero for  $\kappa = 1$ . Only values for  $\kappa > 1$  were considered, since it was assumed that the process started in-control. In theory a value of  $\kappa = 1$  implies that the process was out-of-control from the start of production. This can be viewed as if the process was "in-control" at an out-of-control value for the variance which would imply that charting statistics are independent since all the collected samples come from a normal distribution with the same out-of-control value for the variance. This would imply that the correlation is zero. Panel (v) plots the correlation as a function of the sample size (i.e.  $v = n$ ); for individual samples the correlation is smaller.

## 2. GENERALISED MULTIVARIATE BETA TYPE II DISTRIBUTIONS

### 2.7. Conclusion

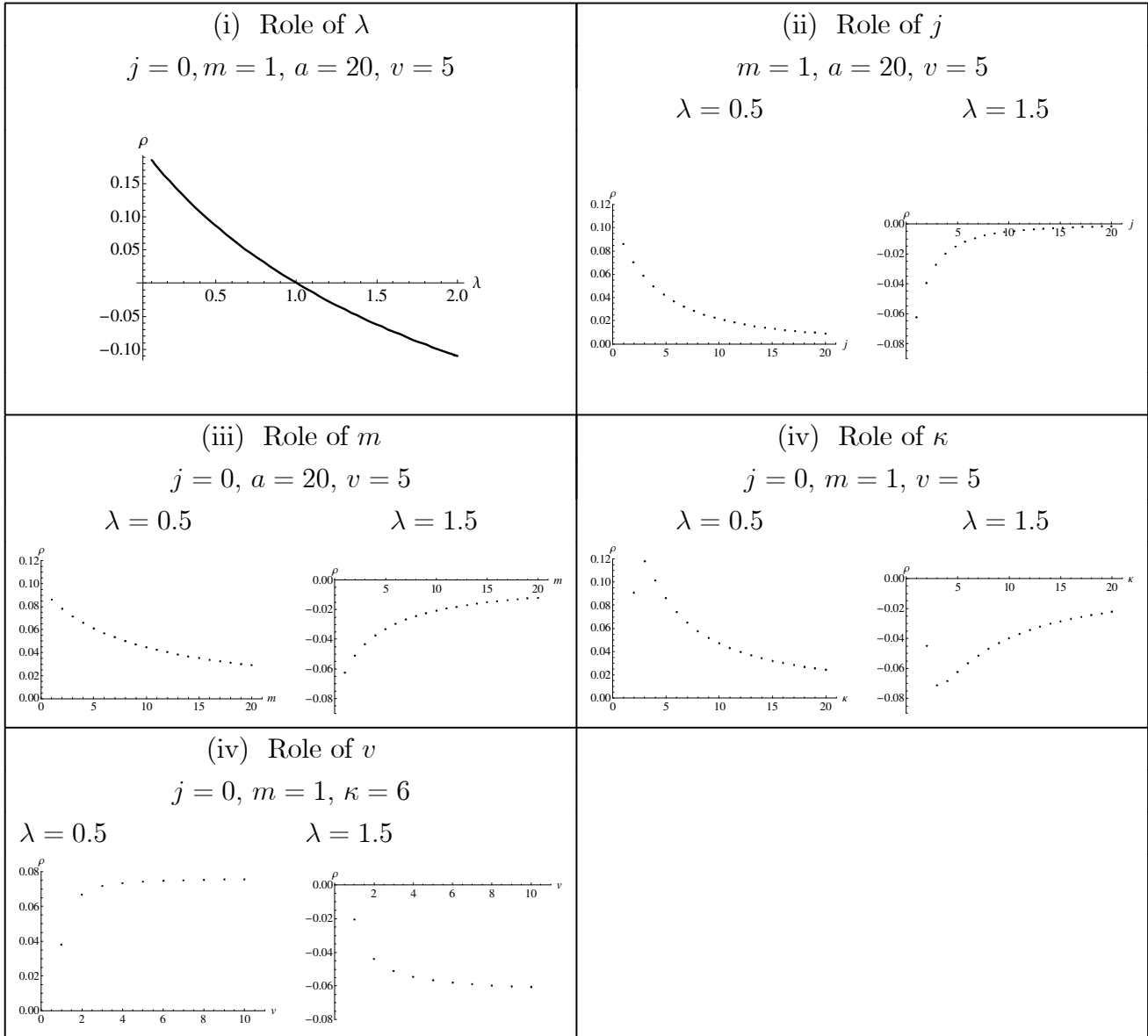

**Figure 2.5** The correlation for different values of the parameters  $\lambda, j, m, v$  and  $\kappa$

## 2.7 Conclusion

A new generalised multivariate beta type II distribution with pdf in a closed form is proposed, emanating from a sequential process where a distribution is needed for the run-length of a Q-chart that monitors the process variance when measurements are from a normal distribution with known mean and unknown variance. The product moments of this generalised multivariate beta distribution are derived to shed light on the nature of this distribution, specifically the correlation structure. In Chapter 5 an example will demonstrate the calculation of run-length probabilities by making use of the exact expressions of the distribution of the charting statistics.

## Chapter 3

# Noncentral generalised multivariate beta type II distributions

### 3.1 Introduction

In this chapter the noncentral generalised multivariate beta type II distribution is proposed. This distribution emanates from a sequential process and is constructed from independent noncentral chi-squared random variables using the variables in common technique. This is a new contribution to the existing noncentral beta type II distributions considered in the literature. A brief overview of relevant noncentral univariate, bivariate and multivariate cases will be highlighted in order to contextualise this new distribution that will be derived. Tang (1938) [44] studied the distribution of the ratios of noncentral chi-squared random variables defined on the positive domain. In this paper of Tang, the ratio (consisting of independent random variables) is considered, where the numerator is a noncentral chi-squared random variable while the denominator is a central chi-squared random variable. Also presented is the ratio where both the numerator and denominator are noncentral chi-squared random variables - this was applied to study the properties of analysis of variance tests under nonstandard conditions. Patnaik (1949) [38] coined the phrase noncentral  $F$  for the first ratio. The second ratio is referred to as the doubly noncentral  $F$  distribution. Let  $X$  and  $W_0$  be independent noncentral chi-squared random variables (see (B.32)) with degrees of freedom  $a$  and  $v_0$  and noncentrality parameters  $\delta_a$  and  $\delta_0$ , respectively. According to Tang (1938) [44] the pdf of the random variable

$$U_0 = \frac{W_0}{X}, \quad (3.1)$$

is

### 3. NONCENTRAL GENERALISED MULTIVARIATE BETA TYPE II DISTRIBUTIONS

#### 3.1. Introduction

$$f(u_0) = \sum_{k_1=0}^{\infty} \sum_{k_2=0}^{\infty} \frac{\Gamma\left(\frac{a}{2} + \frac{v_0}{2} + k_1 + k_2\right) \delta_0^{k_1} \delta_a^{k_2} e^{-(\delta_a + \delta_0)} \frac{v_0}{2} + k_1 - 1}{\Gamma\left(\frac{v_0}{2} + k_1\right) \Gamma\left(\frac{a}{2} + k_2\right) k_1! k_2!} \left(\frac{1}{1 + u_0}\right)^{\frac{a}{2} + k_2 + 1}, \quad (3.2)$$

$u_0 > 0.$

Setting  $\delta_a = 0$  in (3.2) gives the pdf for the first ratio mentioned above i.e. the case with central chi-squared distributed random variables in the numerator. The stochastic representation of the noncentral  $F$  distribution (see Patnaik, 1949 [38]) is

$$U'_0 = \frac{W_0/v_0}{X/a}, \quad (3.3)$$

where  $W_0$  has a noncentral chi-squared distribution with degrees of freedom  $v_0$  and non-centrality parameter  $\delta_0$ , but  $X$  has a central chi-squared distribution with  $a$  degrees of freedom. The pdf is given by

$$f(u'_0) = \sum_{k=0}^{\infty} \frac{\Gamma\left(\frac{a}{2} + \frac{v_0}{2} + k\right) \left(\frac{\delta_0}{2}\right)^k e^{-\frac{\delta_0}{2}}}{\Gamma\left(\frac{v_0}{2} + k\right) \Gamma\left(\frac{a}{2}\right) k!} \left(\frac{v_0}{a}\right)^{\frac{v_0}{2} + k} (u'_0)^{\frac{v_0}{2} + k - 1} \left(1 + \frac{v_0}{a} u'_0\right)^{-\left(\frac{a}{2} + \frac{v_0}{2}\right) - k}, \quad (3.4)$$

$u'_0 > 0.$

An overview of these distributions is given by Johnson et al. (1995) [22]. More recently Pe and Drygas (2006) [39] proposed an alternative presentation for the doubly noncentral  $F$  distribution (see (3.2)) by using the results on the product of two hypergeometric functions. The pdf is given by

$$f(u_0) = e^{-\left(\frac{\delta_a}{2} + \frac{\delta_0}{2}\right)} \sum_{k=0}^{\infty} \frac{\Gamma\left(\frac{a}{2} + \frac{v_0}{2} + k\right) \left(\frac{\delta_0}{2}\right)^k \delta_a^{k_2}}{\Gamma\left(\frac{v_0}{2} + k\right) \Gamma\left(\frac{a}{2}\right) k!} \frac{u_0^{\frac{v_0}{2} + k - 1}}{(1 + u_0)^{\frac{a}{2} + \frac{v_0}{2} + k}} {}_2F_1\left(1 - \frac{v_0}{2} - k, -k; \frac{a}{2}; \frac{\delta_a}{\delta_0 u_0}\right),$$

$u_0 > 0, \left|\frac{\delta_a}{\delta_0 u_0}\right| < 1.$

In a bivariate context Gupta et al. (2009) [14] derived a noncentral bivariate beta type I distribution, using a ratio of noncentral gamma random variables, that is defined on the unit square; applying the appropriate transformation yield a noncentral beta type II distribution defined on the positive domain. After the transformation the random variables of interest are

$$U_0 = \frac{W_0}{X}, \quad U_1 = \frac{W_1}{X}, \quad (3.5)$$

where  $W_0, W_1$  have standard gamma distributions with parameters  $v_0$  and  $v_1$ , respectively

### 3. NONCENTRAL GENERALISED MULTIVARIATE BETA TYPE II DISTRIBUTIONS

#### 3.1. Introduction

and  $X$  has a noncentral gamma distribution with parameters  $(1, a, \delta_a)$ . The pdf of (3.5) is

$$f(u_0, u_1) = \frac{e^{-\frac{\delta_a}{2}} \Gamma(a + v_0 + v_1)}{\Gamma(a) \Gamma(v_0) \Gamma(v_1)} \frac{u_0^{v_0-1} u_1^{v_1-1}}{(1+u_0+u_1)^{a+v_0+v_1}} {}_1F_1\left(a + v_0 + v_1; a; \frac{\delta_a}{1+u_0+u_1}\right),$$

$u_0, u_1 > 0.$

The noncentral Dirichlet type II distribution was derived by Troskie (1967) [46] as the joint distribution of

$$U_j = \frac{W_j}{X}, \quad j = 0, 2, \dots, p,$$

where  $W_j$  is chi-squared distributed with degrees of freedom  $v_j$  and  $X$  has a noncentral chi-squared distribution with  $a$  degrees of freedom and noncentrality parameter  $\delta_a$ . The pdf of  $U_0, U_1, \dots, U_p$  is

$$f(u_0, u_1, \dots, u_p) = \frac{\Gamma\left(\frac{a}{2} + \sum_{j=0}^p \frac{v_j}{2}\right) e^{-\frac{1}{2}\delta_a}}{\Gamma\left(\frac{a}{2}\right) \prod_{j=0}^p \Gamma\left(\frac{v_j}{2}\right)} \left(\prod_{j=0}^p u_j^{\frac{v_j}{2}-1}\right) \left(1 + \sum_{j=0}^p u_j\right)^{-\left(\frac{a}{2} + \sum_{j=0}^p \frac{v_j}{2}\right)}$$

$$\times {}_1F_1\left(\frac{a}{2} + \sum_{j=0}^p \frac{v_j}{2}; \frac{a}{2}; \frac{\frac{1}{2}\delta_a}{1 + \sum_{j=0}^p u_j}\right), \quad u_j > 0, j = 0, 1, \dots, p.$$

Sánchez et al. (2006) [43] stated the pdf of the version where both  $W_j$  and  $X$  are non-central gamma random variables with parameters  $(\alpha, v_j, \delta_j)$  and  $(\alpha, a, \delta_a)$ , respectively as

$$f(u_0, u_1, \dots, u_p)$$

$$= \frac{\Gamma\left(a + \sum_{j=0}^p v_j\right) e^{-(\delta_a + \sum_{j=0}^p \delta_j)}}{\Gamma(a) \prod_{j=0}^p \Gamma(v_j)} \left(\prod_{j=0}^p u_j^{v_j-1}\right) \left(1 + \sum_{j=0}^p u_j\right)^{-(a + \sum_{j=0}^p v_j)}$$

$$\times \Psi_2^{(p+2)}\left[a + \sum_{j=0}^p v_j; v_0, \dots, v_p, a; \frac{\delta_0 u_0}{1 + \sum_{j=0}^p u_j}, \dots, \frac{\delta_p u_p}{1 + \sum_{j=0}^p u_j}, \frac{\delta_a}{1 + \sum_{j=0}^p u_j}\right],$$

$u_j > 0, j = 0, 1, \dots, p,$

where  $\Psi_2^{(p+2)}$  is the confluent hypergeometric function in  $p+2$  variables (see (B.11)) with

### 3. NONCENTRAL GENERALISED MULTIVARIATE BETA TYPE II DISTRIBUTIONS

#### 3.2. Problem statement

---

the values of the parameters such that  $f(u_0, u_1, \dots, u_p)$  is a valid pdf.

Section 3.2 provides an overview of the practical problem which is the genesis of the random variables  $U_0 = \frac{\lambda W_0}{X}$  and  $U_j = \frac{\lambda W_j}{X + \lambda \sum_{k=0}^{j-1} W_k}$ ,  $j = 1, 2, \dots, p$  with  $\lambda > 0$  where  $X$  and  $W_i$ ,  $i = 0, 1, \dots, p$  are noncentral chi-squared distributed (see also (2.7)). In Section 3.3 the distribution of the first three random variables, i.e.  $U_0, U_1, U_2$  is derived. Bivariate pdfs and univariate pdfs of  $(U_0, U_1, U_2)$  also receive attention. Section 3.4 proposes a multivariate extension, followed by a shape analysis in Section 3.5. An example of determining the probability to detect the shift in the variance immediately is discussed in Chapter 5.

## 3.2 Problem statement

Monitoring the unknown process variance when the known location parameter sustained a permanent shift leads to a noncentral version of the generalised multivariate beta type II distribution proposed in Chapter 2. The derivation of this new noncentral generalised multivariate beta type II distribution will be discussed in two steps. Firstly, the practical setting which motivates the derivation of the distribution is described, and secondly the distributions are derived in Sections 3.3 and 3.4.

In the same way as Chapter 2, let  $(Y_{i1}, Y_{i2}, \dots, Y_{in_i})$ ,  $i = 1, 2, \dots$  represent successive, independent samples of size  $n_i \geq 1$  measurements made on a sequence of items produced in time. Assume that these values are independent and identically distributed having been collected from a  $N(\mu_0, \sigma^2)$  distribution where the parameters  $\mu_0$  and  $\sigma^2$  denotes the known process mean and unknown process variance, respectively. Take note that a sample can even consist of an individual observation because the process mean is assumed to be known and the variance of the sample can still be calculated as  $S_i^2 = (Y_{i1} - \mu_0)^2$ ,  $i = 1, 2, \dots$ . Suppose that the unknown process variance has encountered a permanent upward or downward step shift between samples (time periods)  $\kappa - 1$  and  $\kappa$  with  $\kappa > 1$  from  $\sigma^2$  to  $\sigma_1^2 = \lambda \sigma^2$  (also unknown), where  $\lambda \neq 1$  and  $\lambda > 0$ . Additionally, suppose that the known process mean also encountered an unknown sustained shift between samples (time periods)  $d - 1$  and  $d$  where  $1 < d < \kappa$ , i.e. it changed from  $\mu_0$  to  $\mu_1$  where  $\mu_1$  is also known. To clarify, the mean of the process at start-up is assumed to be known and denoted by  $\mu_0$  but the time and the size of the shift in the mean will be unknown in a practical situation. In order to incorporate and/or evaluate the influence of the change in the mean on the performance of the control chart for the variance, assume fixed/deterministic values for the mean – essentially this implies then that the mean is known following the shift, i.e. denoted by  $\mu_1$ . Note that, in practice  $d, \kappa$  and  $\lambda$  would

### 3. NONCENTRAL GENERALISED MULTIVARIATE BETA TYPE II DISTRIBUTIONS

#### 3.2. Problem statement

be unknown (but deterministic) values. Therefore, the main interest is in monitoring the process variance when the process mean is known, although this mean can suffer an unknown shift at some point in time.

Based on the time of the shift in the process mean, this problem can be viewed in three ways, as illustrated in Figure 3.1.

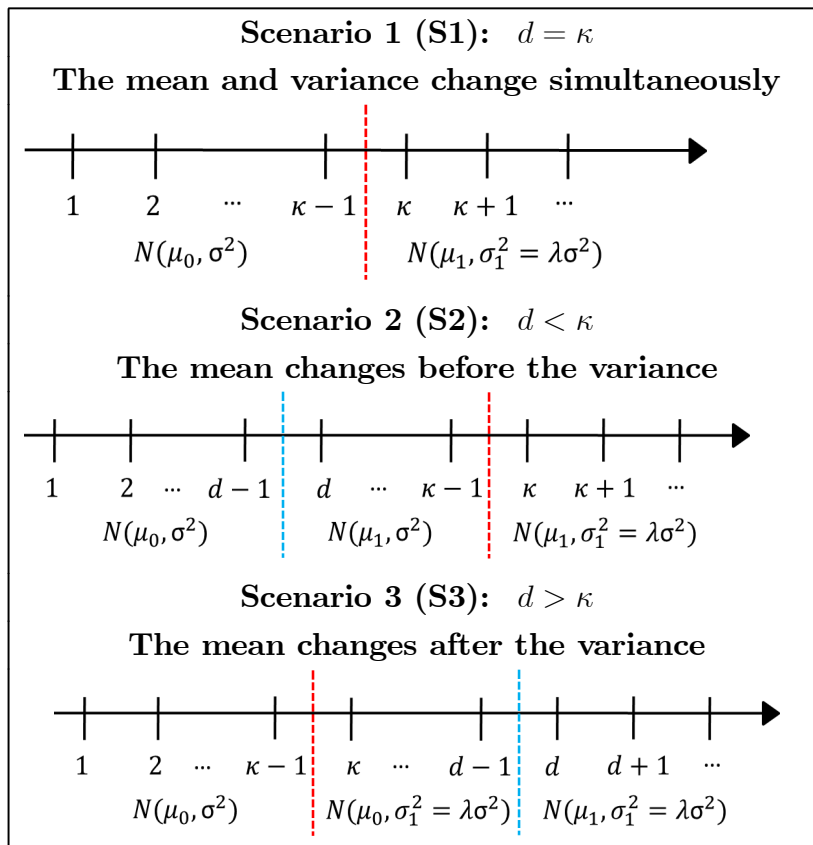

**Figure 3.1** The scenarios for monitoring the variance when the mean also encountered a shift

From Figure 3.1 the following is evident:

Scenario 1: the mean and the variance change simultaneously from  $\mu_0$  to  $\mu_1$  and from  $\sigma^2$  to  $\sigma_1^2$ , respectively. Note that, it is assumed that the shift in the process parameters occurs somewhere between samples  $\kappa - 1$  and  $\kappa$ .

Scenario 2: the change in the mean from  $\mu_0$  to  $\mu_1$  occurs before the change in the variance from  $\sigma^2$  to  $\sigma_1^2$ .

Scenario 3: the change in the variance from  $\sigma^2$  to  $\sigma_1^2$  occurs before the change in the mean from  $\mu_0$  to  $\mu_1$ .

Like in Chapter 2, it is assumed that the process starts in-control and that the variance  $\sigma^2$  is unknown, therefore the first sample is used to obtain an initial estimate of  $\sigma^2$ .

### 3. NONCENTRAL GENERALISED MULTIVARIATE BETA TYPE II DISTRIBUTIONS

#### 3.2. Problem statement

This initial estimate is continuously updated using the new incoming samples as they are collected, as long as a change in the estimated value of  $\sigma^2$  is not detected using the control chart. The control chart and the charting statistic are based on the in-control distribution of the process. This sequential updating and testing procedure is based on the two sample test statistic for testing the hypothesis at time  $r$  that the two independent samples (the measurements of the  $r^{\text{th}}$  sample alone and the measurements of the first  $r - 1$  samples combined) are from normal distributions with the same unknown variance, and is given by (see (2.1) and (2.2))

$$U_r^* = \frac{S_r^2}{S_{r-1}^{2\text{pooled}}} \text{ for } r = 2, 3, \dots, \quad (3.6)$$

$$\text{where } S_{r-1}^{2\text{pooled}} = \frac{\sum_{i=1}^{r-1} n_i S_i^2}{\sum_{i=1}^{r-1} n_i} \text{ and } S_i^2 = \frac{1}{n_i} \sum_{k=1}^{n_i} (Y_{ik} - \mu_i)^2 \text{ for } i = 1, 2, \dots, r.$$

[Take note:  $\mu_i$  denotes the known population mean of sample  $i$ .]

The focus will again be on the part where the process is out-of-control, i.e. encountered a shift, since the exact distribution of the charting statistic is then unknown. As in Chapter 2, to simplify the notation used in expression (3.6) following a change in the process variance between samples  $\kappa - 1$  and  $\kappa$ , define the random variable (see (2.3))

$$U_0^* \equiv U_\kappa^* = \frac{S_\kappa^2}{S_{\kappa-1}^{2\text{pooled}}}. \quad (3.7)$$

The subscript of the random variable  $U_0^*$  indicates the number of samples after the process variance encountered a shift, with zero indicating the first sample after the process parameter has changed.

Note that, the three scenarios can theoretically occur with equal probability as there would be no reason to expect (without additional information such as expert knowledge about the process being monitored) that the mean would sustain a change prior to the variance (and vice versa). In fact, it might be more realistic to argue that in practice the mean and variance would change simultaneously in the event of a “special cause”, as such an event might change the entire underlying process generating distribution; hence both the location and variability might be affected. Having said the aforementioned, the likelihood of the three scenarios will most likely depend on the interaction between the underlying process distribution and the special causes that may occur. The focus of this chapter is on scenario 2 displayed in Figure 3.1 since the results for the other scenarios follow by means of simplifications (by setting the noncentrality parameter equal to zero)



### 3. NONCENTRAL GENERALISED MULTIVARIATE BETA TYPE II DISTRIBUTIONS

#### 3.2. Problem statement

---

and will be shown as remarks.

Consider the sample variance, i.e.  $S_i^2$ , before and after the shifts in the process mean and variance took place:

**Before the shift in the mean:**

Samples:  $i = 1, 2, \dots, d - 1$

Distribution:  $Y_{ik} \sim N(\mu_0, \sigma^2)$

$$S_i^2 = \frac{1}{n_i} \sum_{k=1}^{n_i} (Y_{ik} - \mu_0)^2$$

$$\frac{n_i S_i^2}{\sigma^2} \sim \chi^2(n_i).$$

**After the shift in the mean:**

Samples:  $i = d, \dots, \kappa - 1$

Distribution:  $Y_{ik} \sim N(\mu_1 = \mu_0 + \xi_0 \sigma, \sigma^2)$

[Take note: The observer is unaware of the shift in the process mean and therefore still wrongly assumes  $Y_{ik} \sim N(\mu_0, \sigma^2)$ .]

$$S_i^2 = \frac{1}{n_i} \sum_{k=1}^{n_i} (Y_{ik} - \mu_0)^2$$

$$n_i S_i^2 = \sum_{k=1}^{n_i} (Y_{ik} - \mu_1 + \mu_1 - \mu_0)^2$$

$$\frac{n_i S_i^2}{\sigma^2} = \sum_{k=1}^{n_i} \left( \frac{Y_{ik} - \mu_1}{\sigma} + \frac{\mu_1 - \mu_0}{\sigma} \right)^2$$

$$= \sum_{k=1}^{n_i} (Z_{ik} + \xi_0)^2 \text{ where } Z_{ik} \sim N(0, 1)$$

$$\sim \chi_{\delta_i}^2(n_i)$$

$$\text{where } \delta_i = \sum_{k=1}^{n_i} \xi_0^2 = n_i \xi_0^2 > 0 \text{ with } \xi_0 = \frac{\mu_1 - \mu_0}{\sigma}.$$

**After the shift in the mean and variance:**

Samples:  $i = \kappa, \kappa + 1, \dots$

Distribution:  $Y_{ik} \sim N(\mu_1 = \mu_0 + \xi_1 \sigma_1, \sigma_1^2 = \lambda \sigma^2)$

[Take note: The observer is unaware of the shifts in the process parameters and therefore still wrongly assumes  $Y_{ik} \sim N(\mu_0, \sigma^2)$ .]

$$S_i^2 = \frac{1}{n_i} \sum_{k=1}^{n_i} (Y_{ik} - \mu_0)^2$$

$$n_i S_i^2 = \sum_{k=1}^{n_i} (Y_{ik} - \mu_1 + \mu_1 - \mu_0)^2$$

### 3. NONCENTRAL GENERALISED MULTIVARIATE BETA TYPE II DISTRIBUTIONS

#### 3.2. Problem statement

$$\begin{aligned}
 \frac{n_i S_i^2}{\sigma_1^2} &= \sum_{k=1}^{n_i} \left( \frac{Y_{ik} - \mu_1}{\sigma_1} + \frac{\mu_1 - \mu_0}{\sigma_1} \right)^2 \\
 &= \sum_{k=1}^{n_i} (Z_{ik} + \xi_1)^2 \text{ where } Z_{ik} \sim N(0, 1) \\
 &\sim \chi_{\delta_i}^{\prime 2}(n_i) \\
 \text{where } \delta_i &= \sum_{k=1}^{n_i} \xi_1^2 = n_i \xi_1^2 > 0 \text{ with } \xi_1 = \frac{\mu_1 - \mu_0}{\sigma_1}.
 \end{aligned}$$

**Remark 3.1**

- (i)  $\chi_{\delta_i}^{\prime 2}(n_i)$  denotes the noncentral chi-squared distribution with degrees of freedom  $n_i$  and noncentrality parameter  $\delta_i$  (see (B.32)).
- (ii) The shift in the mean, before the variance changed, is modelled as follows:  $\xi_0 = \frac{\mu_1 - \mu_0}{\sigma}$ , i.e.  $\mu_1 = \mu_0 + \xi_0 \sigma$ .
- (iii) The shift in the mean, after the variance changed, is modelled as follows:  $\xi_1 = \frac{\mu_1 - \mu_0}{\sigma_1}$ , i.e.  $\mu_1 = \mu_0 + \xi_1 \sigma_1$ .
- (iv) The key to the noncentral case is the fact that the observer is unaware of the change in the mean since the charting statistics and the transformations used depends on the in-control distribution of the process. In practice it is important to note that even though the mean and the variance of the normal distribution can change independently (i.e. the mean changes without affecting the variance and vice versa), the performance of a Shewhart-type control chart for the variance depends on the process mean. This dependency stems from the charting statistics used and the manner in which the control limits of a Shewhart-type control chart are calculated (see e.g. Montgomery, 2009 [31]). To clarify, the known mean is used to calculate the sample variance. If the mean value changes but it is not incorporated in the variance calculation, the sample variance will be inflated. This could lead to the control chart signalling that there is a change in the variance even though this is not the case. Therefore, the focus is on deriving the joint distribution of the charting statistics of the Shewhart-type Q-chart for detecting changes in the unknown variance, while accounting for the impact that a change in the known mean will have on the performance of this chart. This impact is analysed by incorporating the possibility of changes in both the mean and variance in the underlying data generating distribution.
- (v) From (iv) it is evident that the proposed control chart could be useful in practice when the control chart for monitoring the mean fails to detect the shift in the mean. For

### 3. NONCENTRAL GENERALISED MULTIVARIATE BETA TYPE II DISTRIBUTIONS

#### 3.2. Problem statement

*example, in case a small shift in the mean occurs and a Shewhart-type chart for the mean is used (which is known for the inefficiency in detecting small shifts compared to the EWMA and CUSUM charts for the mean which are better in detecting small shifts (see Montgomery, 2009 [31]) the shift might go undetected.*

Following a change in the variance between samples  $\kappa - 1$  and  $\kappa$ , (3.7) can be rewritten as (see (2.4)):

$$\begin{aligned}
 U_0^* &= \frac{S_\kappa^2}{S_{\kappa-1}^2 \text{pooled}} \\
 &= \sum_{i=1}^{\kappa-1} n_i \times \frac{S_\kappa^2}{\sum_{i=1}^{d-1} n_i S_i^2 + \sum_{i=d}^{\kappa-1} n_i S_i^2} \\
 &= \frac{\sum_{i=1}^{\kappa-1} n_i}{n_\kappa} \times \frac{\frac{n_\kappa S_\kappa^2}{\sigma_1^2} \times \frac{\sigma_1^2}{\sigma^2}}{\sum_{i=1}^{d-1} \frac{n_i S_i^2}{\sigma^2} + \sum_{i=d}^{\kappa-1} \frac{n_i S_i^2}{\sigma^2}} \\
 &= \frac{\sum_{i=1}^{\kappa-1} n_i}{n_\kappa} \times \frac{\lambda W_0}{X},
 \end{aligned}$$

where, as before,  $\lambda = \frac{\sigma_1^2}{\sigma^2}$  (see (2.5)),

but now,

$$W_0 \equiv \frac{n_\kappa S_\kappa^2}{\sigma_1^2} \sim \chi_{\delta_\kappa}^2(n_\kappa) \text{ and}$$

$$X \equiv \sum_{i=1}^{d-1} \frac{n_i S_i^2}{\sigma^2} + \sum_{i=d}^{\kappa-1} \frac{n_i S_i^2}{\sigma^2} = \sum_{i=1}^{\kappa-1} \frac{n_i S_i^2}{\sigma^2} \sim \chi_{\delta_a}^2(a) \text{ with } a = \sum_{i=1}^{\kappa-1} n_i \text{ and } \delta_a = \sum_{i=1}^{\kappa-1} \delta_i,$$

$$\text{where } \delta_i = \begin{cases} 0 & \text{for } i = 1, \dots, d-1 \\ n_i \xi_0^2 > 0 & \text{with } \xi_0 = \frac{\mu_1 - \mu_0}{\sigma} \text{ for } i = d, \dots, \kappa-1 \\ n_\kappa \xi_1^2 > 0 & \text{with } \xi_1 = \frac{\mu_1 - \mu_0}{\sigma_1} \text{ for } i = \kappa. \end{cases}$$

$$\text{Take note: } \sum_{i=1}^{d-1} \chi^2(n_i) \stackrel{d}{=} \sum_{i=1}^{d-1} \chi_0^2(n_i).$$

### 3. NONCENTRAL GENERALISED MULTIVARIATE BETA TYPE II DISTRIBUTIONS

#### 3.2. Problem statement

In general, at sample  $\kappa + j$ , where  $\kappa > 1$  and  $j = 1, 2, \dots, p$  define the following sequence of random variables (see (2.6)):

$$\begin{aligned}
 U_j^* &= \frac{S_{\kappa+j}^2}{S_{\kappa+j-1}^2} \\
 &= \sum_{i=1}^{\kappa+j-1} n_i \times \frac{S_{\kappa+j}^2}{\sum_{i=1}^{d-1} n_i S_i^2 + \sum_{i=d}^{\kappa-1} n_i S_i^2 + \sum_{i=\kappa}^{\kappa+j-1} n_i S_i^2} \\
 &= \frac{\sum_{i=1}^{\kappa+j-1} n_i}{n_{\kappa+j}} \times \frac{\frac{n_{\kappa+j} S_{\kappa+j}^2}{\sigma_1^2} \times \frac{\sigma_1^2}{\sigma^2}}{\sum_{i=1}^{d-1} \frac{n_i S_i^2}{\sigma^2} + \sum_{i=d}^{\kappa-1} \frac{n_i S_i^2}{\sigma^2} + \sum_{i=\kappa}^{\kappa+j-1} \frac{n_i S_i^2}{\sigma_1^2} \times \frac{\sigma_1^2}{\sigma^2}} \\
 &= \frac{\sum_{i=1}^{\kappa+j-1} n_i}{n_{\kappa+j}} \times \frac{\frac{n_{\kappa+j} S_{\kappa+j}^2}{\sigma_1^2} \times \frac{\sigma_1^2}{\sigma^2}}{\sum_{i=1}^{d-1} \frac{n_i S_i^2}{\sigma^2} + \sum_{i=d}^{\kappa-1} \frac{n_i S_i^2}{\sigma^2} + \sum_{k=0}^{j-1} \frac{n_{\kappa+k} S_{\kappa+k}^2}{\sigma_1^2} \times \frac{\sigma_1^2}{\sigma^2}} \\
 &= \frac{\sum_{i=1}^{\kappa+j-1} n_i}{n_{\kappa+j}} \times \frac{\lambda W_j}{X + \lambda \sum_{k=0}^{j-1} W_k},
 \end{aligned}$$

where

$$\lambda = \frac{\sigma_1^2}{\sigma^2},$$

$$W_i \equiv \frac{n_{\kappa+i} S_{\kappa+i}^2}{\sigma_1^2} \sim \chi_{\delta_i}^2(n_{\kappa+i}),$$

$$X \equiv \sum_{i=1}^{d-1} \frac{n_i S_i^2}{\sigma^2} + \sum_{i=d}^{\kappa-1} \frac{n_i S_i^2}{\sigma^2} = \sum_{i=1}^{\kappa-1} \frac{n_i S_i^2}{\sigma^2} \sim \chi_{\delta_a}^2(a) \text{ with } a = \sum_{i=1}^{\kappa-1} n_i \text{ and } \delta_a = \sum_{i=1}^{\kappa-1} \delta_i,$$

$$\text{where } \delta_i = \begin{cases} 0 & \text{for } i = 1, \dots, d-1 \\ n_i \xi_0^2 > 0 \text{ with } \xi_0 = \frac{\mu_1 - \mu_0}{\sigma} & \text{for } i = d, \dots, \kappa-1 \\ n_i \xi_1^2 > 0 \text{ with } \xi_1 = \frac{\mu_1 - \mu_0}{\sigma_1} & \text{for } i = \kappa, \dots, \kappa+j. \end{cases}$$

In the same way as Chapter 2, the deterministic factors,  $\sum_{i=1}^{\kappa-1} n_i/n_\kappa$  and  $\sum_{i=1}^{\kappa+j-1} n_i/n_{\kappa+j}$ , respectively are omitted and the (\*) superscript dropped. Therefore, the random variables of interest are (see (2.7)):

$$U_0 = \frac{\lambda W_0}{X}, \tag{3.8}$$

$$U_j = \frac{\lambda W_j}{X + \lambda \sum_{k=0}^{j-1} W_k}, \quad j = 1, 2, \dots, p \text{ and } \lambda > 0,$$

### 3. NONCENTRAL GENERALISED MULTIVARIATE BETA TYPE II DISTRIBUTIONS

#### 3.2. Problem statement

where

$$\lambda = \frac{\sigma_1^2}{\sigma^2} \text{ indicates the unknown size of the shift in the variance,}$$

$$X = \sum_{i=1}^{\kappa-1} \chi_{\delta_i}^2(n_i), \text{ i.e. the sum of } \kappa - 1 \text{ independent noncentral } \chi^2 \text{ random variables,}$$

$$X \sim \chi_{\delta_a}^2(a), \text{ i.e. } X \text{ is a noncentral chi-squared random variable with degrees of freedom}$$

$$a = \sum_{i=1}^{\kappa-1} n_i \text{ and noncentrality parameter } \delta_a = 0 + \sum_{i=d}^{\kappa-1} \delta_i, \quad d < \kappa \text{ where}$$

$$\delta_i = n_i \xi_0^2 \text{ with } \xi_0 = \frac{\mu_1 - \mu_0}{\sigma},$$

$$W_i \sim \chi_{\delta_i}^2(v_i), \text{ i.e. } W_i \text{ is a noncentral chi-squared random variable with degrees of}$$

$$\text{freedom } v_i = n_{\kappa+i} \text{ and noncentrality parameter } \delta_i = n_{\kappa+i} \xi_1^2 \text{ with } \xi_1 = \frac{\mu_1 - \mu_0}{\sigma_1},$$

$$i = 0, 1, \dots, p.$$

The random variable  $X$  in (3.8) relates to the process before the change in the variance occurred, while the components  $W_i$ ,  $i = 0, 1, \dots, p$ , relate to the process after the change in the variance occurred. The noncentrality of these chi-squared random variables is dependent on whether a shift in the mean occurred or not, and furthermore the timing of this shift. The influence of the timing of shift in the mean on (3.8) will be highlighted in the remark that follows.

#### Remark 3.2

(i) *Scenarios 1 and 3 of Figure 3.1 can be obtained as follows:*

*When the process mean and variance change simultaneously (scenario 1), i.e.  $d = \kappa$ , then  $\delta_a = 0$ , i.e. the component  $X$  in (3.8) reduces to a central chi-squared random variable. The superscript (S1) in the expressions that follow indicate scenario 1 as discussed and shown in Figure 3.1. From (3.8) it then follows that*

$$U_0^{(S1)} = \frac{\lambda W_0}{X},$$

$$U_j^{(S1)} = \frac{\lambda W_j}{X + \lambda \sum_{k=0}^{j-1} W_k}, \quad j = 1, 2, \dots, p \text{ and } \lambda > 0,$$

where

$$X = \sum_{i=1}^{\kappa-1} \chi^2(n_i) \sim \chi^2(a) \text{ with } a = \sum_{i=1}^{\kappa-1} n_i,$$

$$W_i \sim \chi_{\delta_i}^2(v_i) \text{ with } v_i = n_{\kappa+i}, \delta_i = n_{\kappa+i} \xi_1^2 \text{ and } \xi_1 = \frac{\mu_1 - \mu_0}{\sigma_1}, \quad i = 0, 1, \dots, p.$$

*For scenario 3, the process variance has changed between samples (time periods)  $\kappa - 1$  and  $\kappa > 1$ , but the process mean encountered a sustained shift between samples (time periods)  $d - 1$  and  $d$  where  $d > \kappa$ , i.e. the mean changed after the variance. The random variables  $X$  and  $W_i$  for  $i = 0, 1, \dots, d - 1$  that relate to the process before*

### 3. NONCENTRAL GENERALISED MULTIVARIATE BETA TYPE II DISTRIBUTIONS

#### 3.3. The noncentral generalised trivariate beta type II distribution

---

the change in the mean occurred reduce to central chi-squared random variables i.e.  $\delta_a = 0$  and  $\delta_i = 0$  for  $i = 0, 1, \dots, d-1$ . The random variables in (3.8) will change as follows:

$$U_0^{(S3)} = \frac{\lambda W_0}{X},$$

$$U_j^{(S3)} = \frac{\lambda W_j}{X + \lambda \sum_{k=0}^{j-1} W_k}, \quad j = 1, 2, \dots, p \text{ and } \lambda > 0,$$

where

$$X = \sum_{i=1}^{\kappa-1} \chi^2(n_i) \sim \chi^2(a) \text{ with } a = \sum_{i=1}^{\kappa-1} n_i,$$

$$W_i \sim \chi_{\delta_i}^2(v_i) \text{ with } v_i = n_{\kappa+i}, \delta_i = \begin{cases} 0 \text{ for } i = 0, 1, \dots, d-1 \\ n_{\kappa+i} \xi_1^2 \text{ and } \xi_1 = \frac{\mu_1 - \mu_0}{\sigma_1} \text{ for } i = d, d+1, \dots, p. \end{cases}$$

(ii) If the process mean remains unchanged and only the process variance encountered a sustained shift, the components  $X$  and  $W_i$  in (3.8) will reduce to central chi-squared random variables (see (2.7)). The joint distribution of the random variables (3.8) will then be the generalised multivariate beta distribution derived in Chapter 2.

In Section 3.3 the joint distribution of the random variables  $U_0, U_1, U_2$  (see (3.8)) is derived, i.e. the first three random variables following a change in the variance. In Section 3.4 the multivariate extension is considered. The reason for this unorthodox presentation of results is to first demonstrate the different marginals for the trivariate case.

## 3.3 The noncentral generalised trivariate beta type II distribution

The joint pdf of  $U_0, U_1, U_2$  (see (3.8) with  $j = 1, 2$ ) is derived in Theorem 3.1. The bivariate and univariate marginal pdfs of  $U_0, U_1, U_2$  are considered in Theorems 3.2 and 3.3, respectively.

### 3.3.1 The probability density function

**Theorem 3.1** Let  $X, W_i$  with  $i = 0, 1, 2$  be independent noncentral chi-squared random variables with degrees of freedom  $a$  and  $v_i$  and noncentrality parameters  $\delta_a$  and  $\delta_i$  with  $i = 0, 1, 2$ , respectively. Let  $U_0 = \frac{\lambda W_0}{X}$ ,  $U_1 = \frac{\lambda W_1}{X + \lambda W_0}$  and  $U_2 = \frac{\lambda W_2}{X + \lambda W_0 + \lambda W_1}$  (see (3.8)) and  $\lambda > 0$ . The joint pdf of  $(U_0, U_1, U_2)$  is given by

### 3. NONCENTRAL GENERALISED MULTIVARIATE BETA TYPE II DISTRIBUTIONS

#### 3.3. The noncentral generalised trivariate beta type II distribution

$$\begin{aligned}
 & f(u_0, u_1, u_2) \\
 &= \frac{e^{-\left(\frac{\delta_a + \delta_0 + \delta_1 + \delta_2}{2}\right)} \lambda^{\frac{a}{2}} \Gamma\left(\frac{a + v_0 + v_1 + v_2}{2}\right)}{\Gamma\left(\frac{a}{2}\right) \Gamma\left(\frac{v_0}{2}\right) \Gamma\left(\frac{v_1}{2}\right) \Gamma\left(\frac{v_2}{2}\right)} u_0^{\frac{v_0}{2} - 1} u_1^{\frac{v_1}{2} - 1} u_2^{\frac{v_2}{2} - 1} (1 + u_0)^{\frac{v_1}{2} + \frac{v_2}{2}} \\
 & \times (1 + u_1)^{\frac{v_2}{2}} [\lambda + u_0 + u_1(1 + u_0) + u_2(1 + u_0)(1 + u_1)]^{-\left(\frac{a + v_0 + v_1 + v_2}{2}\right)} \\
 & \times \Psi_2^{(4)} \left[ \frac{a + v_0 + v_1 + v_2}{2}, \frac{a}{2}, \frac{v_0}{2}, \frac{v_1}{2}, \frac{v_2}{2}, \frac{\lambda \delta_a}{2z}, \frac{\delta_0 u_0}{2z}, \frac{\delta_1 u_1(1 + u_0)}{2z}, \frac{\delta_2 u_2(1 + u_0)(1 + u_1)}{2z} \right], \\
 & \qquad \qquad \qquad u_j > 0, \quad j = 0, 1, 2,
 \end{aligned} \tag{3.9}$$

where  $z = \lambda + u_0 + u_1(1 + u_0) + u_2(1 + u_0)(1 + u_1)$ ,  $\Psi_2^{(4)}$  is the confluent hypergeometric function in four variables (see (B.11)) with the values of the parameters such that  $f(u_0, u_1, u_2)$  is a valid pdf.

**Proof.** The joint pdf of  $X, W_0, W_1, W_2$  is

$$\begin{aligned}
 & f(x, w_0, w_1, w_2) \\
 &= \frac{e^{-\left(\frac{\delta_a}{2} + \frac{\delta_0}{2} + \frac{\delta_1}{2} + \frac{\delta_2}{2}\right)}}{2^{\frac{a}{2} + \frac{v_0}{2} + \frac{v_1}{2} + \frac{v_2}{2}} \Gamma\left(\frac{a}{2}\right) \Gamma\left(\frac{v_0}{2}\right) \Gamma\left(\frac{v_1}{2}\right) \Gamma\left(\frac{v_2}{2}\right)} {}_0F_1\left(\frac{a}{2}; \frac{\delta_a x}{4}\right) {}_0F_1\left(\frac{v_0}{2}; \frac{\delta_0 w_0}{4}\right) \\
 & \times {}_0F_1\left(\frac{v_1}{2}; \frac{\delta_1 w_1}{4}\right) {}_0F_1\left(\frac{v_2}{2}; \frac{\delta_2 w_2}{4}\right) x^{\frac{a}{2} - 1} w_0^{\frac{v_0}{2} - 1} w_1^{\frac{v_1}{2} - 1} w_2^{\frac{v_2}{2} - 1} e^{-\frac{1}{2}(x + w_0 + w_1 + w_2)},
 \end{aligned} \tag{3.10}$$

where  ${}_0F_1(\cdot)$  is defined in (B.8).

Apply the transformation  $U = X, U_0 = \frac{\lambda W_0}{X}, U_1 = \frac{\lambda W_1}{X + \lambda W_0}$  and  $U_2 = \frac{\lambda W_2}{X + \lambda W_0 + \lambda W_1}$  with inverse transformation  $W_0 = \frac{1}{\lambda} U_0 U, W_1 = \frac{1}{\lambda} U_1 U (1 + U_0)$  and  $W_2 = \frac{1}{\lambda} U_2 U (1 + U_0)(1 + U_1)$ , and with Jacobian,

$$\begin{aligned}
 & J(x, w_0, w_1, w_2 \rightarrow u, u_0, u_1, u_2) \\
 &= \begin{vmatrix} 1 & 0 & 0 & 0 \\ \frac{u_0}{\lambda} & \frac{u}{\lambda} & 0 & 0 \\ \frac{u_1(1 + u_0)}{\lambda} & \frac{u_1 u}{\lambda} & \frac{u(1 + u_0)}{\lambda} & 0 \\ \frac{u_2(1 + u_0)(1 + u_1)}{\lambda} & \frac{u_2 u(1 + u_1)}{\lambda} & \frac{u_2 u(1 + u_0)}{\lambda} & \frac{u(1 + u_0)(1 + u_1)}{\lambda} \end{vmatrix} \\
 &= \frac{u^3(1 + u_0)^2(1 + u_1)}{\lambda^3}.
 \end{aligned} \tag{3.11}$$

### 3. NONCENTRAL GENERALISED MULTIVARIATE BETA TYPE II DISTRIBUTIONS

#### 3.3. The noncentral generalised trivariate beta type II distribution

Using (3.10) and (3.11), the joint pdf of  $U, U_0, U_1, U_2$  is

$$\begin{aligned}
 & f(u, u_0, u_1, u_2) \\
 &= \frac{e^{-\left(\frac{\delta_a}{2} + \frac{\delta_0}{2} + \frac{\delta_1}{2} + \frac{\delta_2}{2}\right)}}{2^{\frac{a}{2} + \frac{v_0}{2} + \frac{v_1}{2} + \frac{v_2}{2}} \Gamma\left(\frac{a}{2}\right) \Gamma\left(\frac{v_0}{2}\right) \Gamma\left(\frac{v_1}{2}\right) \Gamma\left(\frac{v_2}{2}\right)} {}_0F_1\left(\frac{a}{2}; \frac{\delta_a u}{4}\right) {}_0F_1\left(\frac{v_0}{2}; \frac{\delta_0 u_0 u}{4\lambda}\right) {}_0F_1\left(\frac{v_1}{2}; \frac{\delta_1 u_1 u(1+u_0)}{4\lambda}\right) \\
 &\quad \times {}_0F_1\left(\frac{v_2}{2}; \frac{v_2}{2}; \frac{\delta_2 u_2 u(1+u_0)(1+u_1)}{4\lambda}\right) u^{\frac{a}{2}-1} \left(\frac{1}{\lambda} u_0 u\right)^{\frac{v_0}{2}-1} \left(\frac{1}{\lambda} u_1 u(1+u_0)\right)^{\frac{v_1}{2}-1} \\
 &\quad \times \left(\frac{1}{\lambda} u_2 u(1+u_0)(1+u_1)\right)^{\frac{v_2}{2}-1} e^{-\frac{1}{2}\left(u + \frac{1}{\lambda} u_0 u + \frac{1}{\lambda} u_1 u(1+u_0) + \frac{1}{\lambda} u_2 u(1+u_0)(1+u_1)\right)} \frac{u^3(1+u_0)^2(1+u_1)}{\lambda^3} \\
 &= \frac{e^{-\left(\frac{\delta_a}{2} + \frac{\delta_0}{2} + \frac{\delta_1}{2} + \frac{\delta_2}{2}\right)} \lambda^{-\left(\frac{v_0}{2} + \frac{v_1}{2} + \frac{v_2}{2}\right)}}{2^{\frac{a}{2} + \frac{v_0}{2} + \frac{v_1}{2} + \frac{v_2}{2}} \Gamma\left(\frac{a}{2}\right) \Gamma\left(\frac{v_0}{2}\right) \Gamma\left(\frac{v_1}{2}\right) \Gamma\left(\frac{v_2}{2}\right)} {}_0F_1\left(\frac{a}{2}; \frac{\delta_a u}{4}\right) {}_0F_1\left(\frac{v_0}{2}; \frac{\delta_0 u_0 u}{4\lambda}\right) {}_0F_1\left(\frac{v_1}{2}; \frac{\delta_1 u_1 u(1+u_0)}{4\lambda}\right) \\
 &\quad \times {}_0F_1\left(\frac{v_2}{2}; \frac{\delta_2 u_2 u(1+u_0)(1+u_1)}{4\lambda}\right) u^{\frac{a}{2} + \frac{v_0}{2} + \frac{v_1}{2} + \frac{v_2}{2} - 1} u_0^{\frac{v_0}{2}-1} u_1^{\frac{v_1}{2}-1} u_2^{\frac{v_2}{2}-1} (1+u_0)^{\frac{v_1}{2} + \frac{v_2}{2}} (1+u_1)^{\frac{v_2}{2}} \\
 &\quad \times e^{-\frac{u}{2}\left(1 + \frac{u_0}{\lambda} + \frac{u_1(1+u_0)}{\lambda} + \frac{u_2(1+u_0)(1+u_1)}{\lambda}\right)}.
 \end{aligned}$$

Expanding the  ${}_0F_1(\cdot)$  expressions in series form (see (B.8)) and integrating with respect to  $u$  using (B.18) gives,

$$\begin{aligned}
 & f(u_0, u_1, u_2) \\
 &= \frac{e^{-\left(\frac{\delta_a}{2} + \frac{\delta_0}{2} + \frac{\delta_1}{2} + \frac{\delta_2}{2}\right)} \lambda^{-\left(\frac{v_0}{2} + \frac{v_1}{2} + \frac{v_2}{2}\right)}}{2^{\frac{a}{2} + \frac{v_0}{2} + \frac{v_1}{2} + \frac{v_2}{2}} \Gamma\left(\frac{a}{2}\right) \Gamma\left(\frac{v_0}{2}\right) \Gamma\left(\frac{v_1}{2}\right) \Gamma\left(\frac{v_2}{2}\right)} u_0^{\frac{v_0}{2}-1} u_1^{\frac{v_1}{2}-1} u_2^{\frac{v_2}{2}-1} (1+u_0)^{\frac{v_1}{2} + \frac{v_2}{2}} (1+u_1)^{\frac{v_2}{2}} \times \\
 &\quad \sum_{k_1=0}^{\infty} \sum_{k_2=0}^{\infty} \sum_{k_3=0}^{\infty} \sum_{k_4=0}^{\infty} \frac{\left(\frac{\delta_a}{4}\right)^{k_1}}{\left(\frac{a}{2}\right)_{k_1} k_1!} \frac{\left(\frac{\delta_0 u_0}{4\lambda}\right)^{k_2}}{\left(\frac{v_0}{2}\right)_{k_2} k_2!} \frac{\left(\frac{\delta_1 u_1(1+u_0)}{4\lambda}\right)^{k_3}}{\left(\frac{v_1}{2}\right)_{k_3} k_3!} \frac{\left(\frac{\delta_2 u_2(1+u_0)(1+u_1)}{4\lambda}\right)^{k_4}}{\left(\frac{v_2}{2}\right)_{k_4} k_4!} \times \\
 &\quad \int_0^{\infty} u^{\frac{a}{2} + \frac{v_0}{2} + \frac{v_1}{2} + \frac{v_2}{2} + k_1 + k_2 + k_3 + k_4 - 1} e^{-\frac{u}{2}\left(1 + \frac{u_0}{\lambda} + \frac{u_1(1+u_0)}{\lambda} + \frac{u_2(1+u_0)(1+u_1)}{\lambda}\right)} du \\
 &= \frac{e^{-\left(\frac{\delta_a}{2} + \frac{\delta_0}{2} + \frac{\delta_1}{2} + \frac{\delta_2}{2}\right)} \lambda^{-\left(\frac{v_0}{2} + \frac{v_1}{2} + \frac{v_2}{2}\right)}}{\Gamma\left(\frac{a}{2}\right) \Gamma\left(\frac{v_0}{2}\right) \Gamma\left(\frac{v_1}{2}\right) \Gamma\left(\frac{v_2}{2}\right)} u_0^{\frac{v_0}{2}-1} u_1^{\frac{v_1}{2}-1} u_2^{\frac{v_2}{2}-1} (1+u_0)^{\frac{v_1}{2} + \frac{v_2}{2}} (1+u_1)^{\frac{v_2}{2}} \quad (3.12) \\
 &\quad \times \sum_{k_1=0}^{\infty} \sum_{k_2=0}^{\infty} \sum_{k_3=0}^{\infty} \sum_{k_4=0}^{\infty} \frac{\left(\frac{\delta_a}{2}\right)^{k_1}}{\left(\frac{a}{2}\right)_{k_1} k_1!} \frac{\left(\frac{\delta_0 u_0}{2\lambda}\right)^{k_2}}{\left(\frac{v_0}{2}\right)_{k_2} k_2!} \frac{\left(\frac{\delta_1 u_1(1+u_0)}{2\lambda}\right)^{k_3}}{\left(\frac{v_1}{2}\right)_{k_3} k_3!} \frac{\left(\frac{\delta_2 u_2(1+u_0)(1+u_1)}{2\lambda}\right)^{k_4}}{\left(\frac{v_2}{2}\right)_{k_4} k_4!} \\
 &\quad \times \left(1 + \frac{u_0}{\lambda} + \frac{u_1(1+u_0)}{\lambda} + \frac{u_2(1+u_0)(1+u_1)}{\lambda}\right)^{-\left(\frac{a}{2} + \frac{v_0}{2} + \frac{v_1}{2} + \frac{v_2}{2} + k_1 + k_2 + k_3 + k_4\right)} \\
 &\quad \Gamma\left(\frac{a}{2} + \frac{v_0}{2} + \frac{v_1}{2} + \frac{v_2}{2} + k_1 + k_2 + k_3 + k_4\right).
 \end{aligned}$$



### 3. NONCENTRAL GENERALISED MULTIVARIATE BETA TYPE II DISTRIBUTIONS

#### 3.3. The noncentral generalised trivariate beta type II distribution

The desired result (3.9) follows easily from simplifying (3.12) and using (B.11),

$$\begin{aligned}
 & f(u_0, u_1, u_2) \\
 &= \frac{e^{-\left(\frac{\delta_0}{2} + \frac{\delta_1}{2} + \frac{\delta_2}{2}\right)} \lambda^{-\left(\frac{v_0}{2} + \frac{v_1}{2} + \frac{v_2}{2}\right)}}{\Gamma\left(\frac{a}{2}\right)\Gamma\left(\frac{v_0}{2}\right)\Gamma\left(\frac{v_1}{2}\right)\Gamma\left(\frac{v_2}{2}\right)} u_0^{\frac{v_0}{2}-1} u_1^{\frac{v_1}{2}-1} u_2^{\frac{v_2}{2}-1} (1+u_0)^{\frac{v_1}{2} + \frac{v_2}{2}} (1+u_1)^{\frac{v_2}{2}} \\
 &\times \sum_{k_1=0}^{\infty} \sum_{k_2=0}^{\infty} \sum_{k_3=0}^{\infty} \sum_{k_4=0}^{\infty} \frac{\left(\frac{\delta_0}{2}\right)^{k_1}}{\left(\frac{a}{2}\right)_{k_1}} \frac{\left(\frac{\delta_0 u_0}{2\lambda}\right)^{k_2}}{k_1! \left(\frac{v_0}{2}\right)_{k_2}} \frac{\left(\frac{\delta_1 u_1(1+u_0)}{2\lambda}\right)^{k_3}}{k_2! \left(\frac{v_1}{2}\right)_{k_3}} \frac{\left(\frac{\delta_2 u_2(1+u_0)(1+u_1)}{2\lambda}\right)^{k_4}}{k_3! \left(\frac{v_2}{2}\right)_{k_4}} \\
 &\times \left(\frac{\lambda + u_0 + u_1(1+u_0) + u_2(1+u_0)(1+u_1)}{\lambda}\right)^{-\left(\frac{a}{2} + \frac{v_0}{2} + \frac{v_1}{2} + \frac{v_2}{2} + k_1 + k_2 + k_3 + k_4\right)} \\
 &\times \frac{\Gamma\left(\frac{a}{2} + \frac{v_0}{2} + \frac{v_1}{2} + \frac{v_2}{2} + k_1 + k_2 + k_3 + k_4\right)}{\Gamma\left(\frac{a}{2} + \frac{v_0}{2} + \frac{v_1}{2} + \frac{v_2}{2}\right)} \Gamma\left(\frac{a}{2} + \frac{v_0}{2} + \frac{v_1}{2} + \frac{v_2}{2}\right) \\
 &= \frac{e^{-\left(\frac{\delta_0}{2} + \frac{\delta_1}{2} + \frac{\delta_2}{2}\right)} \lambda^{\frac{a}{2}} \Gamma\left(\frac{a}{2} + \frac{v_0}{2} + \frac{v_1}{2} + \frac{v_2}{2}\right)}{\Gamma\left(\frac{a}{2}\right)\Gamma\left(\frac{v_0}{2}\right)\Gamma\left(\frac{v_1}{2}\right)\Gamma\left(\frac{v_2}{2}\right)} u_0^{\frac{v_0}{2}-1} u_1^{\frac{v_1}{2}-1} u_2^{\frac{v_2}{2}-1} (1+u_0)^{\frac{v_1}{2} + \frac{v_2}{2}} (1+u_1)^{\frac{v_2}{2}} \\
 &\times [\lambda + u_0 + u_1(1+u_0) + u_2(1+u_0)(1+u_1)]^{-\left(\frac{a}{2} + \frac{v_0}{2} + \frac{v_1}{2} + \frac{v_2}{2}\right)} \\
 &\times \sum_{k_1=0}^{\infty} \sum_{k_2=0}^{\infty} \sum_{k_3=0}^{\infty} \sum_{k_4=0}^{\infty} \frac{\left(\frac{a}{2} + \frac{v_0}{2} + \frac{v_1}{2} + \frac{v_2}{2}\right)_{k_1+k_2+k_3+k_4}}{\left(\frac{a}{2}\right)_{k_1} \left(\frac{v_0}{2}\right)_{k_2} \left(\frac{v_1}{2}\right)_{k_3} \left(\frac{v_2}{2}\right)_{k_4}} \left(\frac{\lambda \delta_0}{2[\lambda + u_0 + u_1(1+u_0) + u_2(1+u_0)(1+u_1)]}\right)^{k_1} \\
 &\times \left(\frac{\delta_0 u_0}{2[\lambda + u_0 + u_1(1+u_0) + u_2(1+u_0)(1+u_1)]}\right)^{k_2} \left(\frac{\delta_1 u_1(1+u_0)}{2[\lambda + u_0 + u_1(1+u_0) + u_2(1+u_0)(1+u_1)]}\right)^{k_3} \\
 &\times \left(\frac{\delta_2 u_2(1+u_0)(1+u_1)}{2[\lambda + u_0 + u_1(1+u_0) + u_2(1+u_0)(1+u_1)]}\right)^{k_4} \\
 &= \frac{e^{-\left(\frac{\delta_0}{2} + \frac{\delta_1}{2} + \frac{\delta_2}{2}\right)} \lambda^{\frac{a}{2}} \Gamma\left(\frac{a}{2} + \frac{v_0}{2} + \frac{v_1}{2} + \frac{v_2}{2}\right)}{\Gamma\left(\frac{a}{2}\right)\Gamma\left(\frac{v_0}{2}\right)\Gamma\left(\frac{v_1}{2}\right)\Gamma\left(\frac{v_2}{2}\right)} u_0^{\frac{v_0}{2}-1} u_1^{\frac{v_1}{2}-1} u_2^{\frac{v_2}{2}-1} (1+u_0)^{\frac{v_1}{2} + \frac{v_2}{2}} (1+u_1)^{\frac{v_2}{2}} \\
 &\times [\lambda + u_0 + u_1(1+u_0) + u_2(1+u_0)(1+u_1)]^{-\left(\frac{a}{2} + \frac{v_0}{2} + \frac{v_1}{2} + \frac{v_2}{2}\right)} \\
 &\times \Psi_2^{(4)} \left[ \frac{a}{2} + \frac{v_0}{2} + \frac{v_1}{2} + \frac{v_2}{2}; \frac{a}{2}, \frac{v_0}{2}, \frac{v_1}{2}, \frac{v_2}{2}; \frac{\lambda \delta_0}{z}, \frac{\delta_0 u_0}{z}, \frac{\delta_1 u_1(1+u_0)}{z}, \frac{\delta_2 u_2(1+u_0)(1+u_1)}{z} \right],
 \end{aligned}$$

where  $z = 2[\lambda + u_0 + u_1(1+u_0) + u_2(1+u_0)(1+u_1)]$ . ■

**Remark 3.3** (i) The expression for the joint pdf of  $(U_0, U_1, U_2)$  in (3.9) can also be obtained by setting  $p = 2$  in (3.28) (see Section 3.4) and applying result (B.12).

(ii) For the special case when  $\lambda = 1$  (i.e. the process variance did not encounter a shift although the mean did), this trivariate pdf (3.9) simplifies to

### 3. NONCENTRAL GENERALISED MULTIVARIATE BETA TYPE II DISTRIBUTIONS

#### 3.3. The noncentral generalised trivariate beta type II distribution

$$\begin{aligned}
 & f(u_0, u_1, u_2) \\
 &= \frac{e^{-\left(\frac{\delta_a + \delta_0 + \delta_1 + \delta_2}{2}\right)} \Gamma\left(\frac{a + v_0 + v_1 + v_2}{2}\right)}{\Gamma\left(\frac{a}{2}\right) \Gamma\left(\frac{v_0}{2}\right) \Gamma\left(\frac{v_1}{2}\right) \Gamma\left(\frac{v_2}{2}\right)} u_0^{\frac{v_0}{2}-1} u_1^{\frac{v_1}{2}-1} u_2^{\frac{v_2}{2}-1} (1 + u_0)^{\frac{v_1}{2} + \frac{v_2}{2}} (1 + u_1)^{\frac{v_2}{2}} \\
 &\quad \times [(1 + u_0)(1 + u_1)(1 + u_2)]^{-\left(\frac{a + v_0 + v_1 + v_2}{2}\right)} \\
 &\quad \times \Psi_2^{(4)} \left[ \frac{a + v_0 + v_1 + v_2}{2}, \frac{a}{2}, \frac{v_0}{2}, \frac{v_1}{2}, \frac{v_2}{2}, \frac{\delta_a}{2y}, \frac{\delta_0 u_0}{2y}, \frac{\delta_1 u_1(1 + u_0)}{2y}, \frac{\delta_2 u_2(1 + u_0)(1 + u_1)}{2y} \right], \\
 &\qquad\qquad\qquad u_j > 0, \quad j = 0, 1, 2,
 \end{aligned}$$

where  $y = (1 + u_0)(1 + u_1)(1 + u_2)$  and the values of the parameters are such that  $f(u_0, u_1, u_2)$  is a valid pdf.

(iii) When the shift in the mean and the variance occurs simultaneously (scenario 1), the noncentrality parameter  $\delta_a = 0$ , and using (B.12) and (B.8) it follows that

$$\begin{aligned}
 & \Psi_2^{(4)} \left[ \frac{a + v_0 + v_1 + v_2}{2}, \frac{a}{2}, \frac{v_0}{2}, \frac{v_1}{2}, \frac{v_2}{2}, 0, \frac{\delta_0 u_0}{2z}, \frac{\delta_1 u_1(1 + u_0)}{2z}, \frac{\delta_2 u_2(1 + u_0)(1 + u_1)}{2z} \right] \\
 &= \frac{1}{\Gamma\left(\frac{a + v_0 + v_1 + v_2}{2}\right)} \int_0^\infty e^{-t} t^{\frac{a + v_0 + v_1 + v_2}{2} - 1} {}_0F_1\left(\frac{a}{2}; 0\right) {}_0F_1\left(\frac{v_0}{2}; \frac{\delta_0 u_0 t}{2z}\right) \\
 &\quad \times {}_0F_1\left(\frac{v_1}{2}; \frac{\delta_1 u_1(1 + u_0)t}{2z}\right) {}_0F_1\left(\frac{v_2}{2}; \frac{\delta_2 u_2(1 + u_0)(1 + u_1)t}{2z}\right) dt \\
 &= \frac{1}{\Gamma\left(\frac{a + v_0 + v_1 + v_2}{2}\right)} \int_0^\infty e^{-t} t^{\frac{a + v_0 + v_1 + v_2}{2} - 1} {}_0F_1\left(\frac{v_0}{2}; \frac{\delta_0 u_0 t}{2z}\right) \\
 &\quad \times {}_0F_1\left(\frac{v_1}{2}; \frac{\delta_1 u_1(1 + u_0)t}{2z}\right) {}_0F_1\left(\frac{v_2}{2}; \frac{\delta_2 u_2(1 + u_0)(1 + u_1)t}{2z}\right) dt \\
 &= \Psi_2^{(3)} \left[ \frac{a + v_0 + v_1 + v_2}{2}, \frac{v_0}{2}, \frac{v_1}{2}, \frac{v_2}{2}, \frac{\delta_0 u_0}{2z}, \frac{\delta_1 u_1(1 + u_0)}{2z}, \frac{\delta_2 u_2(1 + u_0)(1 + u_1)}{2z} \right].
 \end{aligned}$$

The trivariate pdf (3.9) is then given by

$$\begin{aligned}
 & f(u_0, u_1, u_2) \\
 &= \frac{e^{-\left(\frac{\delta_0 + \delta_1 + \delta_2}{2}\right)} \lambda^{\frac{a}{2}} \Gamma\left(\frac{a + v_0 + v_1 + v_2}{2}\right)}{\Gamma\left(\frac{a}{2}\right) \Gamma\left(\frac{v_0}{2}\right) \Gamma\left(\frac{v_1}{2}\right) \Gamma\left(\frac{v_2}{2}\right)} u_0^{\frac{v_0}{2}-1} u_1^{\frac{v_1}{2}-1} u_2^{\frac{v_2}{2}-1} (1 + u_0)^{\frac{v_1}{2} + \frac{v_2}{2}} (1 + u_1)^{\frac{v_2}{2}} \\
 &\quad \times [\lambda + u_0 + u_1(1 + u_0) + u_2(1 + u_0)(1 + u_1)]^{-\left(\frac{a + v_0 + v_1 + v_2}{2}\right)} \\
 &\quad \times \Psi_2^{(3)} \left[ \frac{a + v_0 + v_1 + v_2}{2}, \frac{v_0}{2}, \frac{v_1}{2}, \frac{v_2}{2}, \frac{\delta_0 u_0}{2z}, \frac{\delta_1 u_1(1 + u_0)}{2z}, \frac{\delta_2 u_2(1 + u_0)(1 + u_1)}{2z} \right], \\
 &\qquad\qquad\qquad u_j > 0, \quad j = 0, 1, 2,
 \end{aligned}$$

where  $z = \lambda + u_0 + u_1(1 + u_0) + u_2(1 + u_0)(1 + u_1)$ ,  $\Psi_2^{(3)}$  is the confluent hypergeometric function in three variables (see (B.11)) with the values of the parameters such that  $f(u_0, u_1, u_2)$  is a valid pdf.

### 3. NONCENTRAL GENERALISED MULTIVARIATE BETA TYPE II DISTRIBUTIONS

#### 3.3. The noncentral generalised trivariate beta type II distribution

(iv) When monitoring the variance and the mean did not change, i.e.  $\delta_a = \delta_0 = \delta_1 = \delta_2 = 0$ , the trivariate pdf (3.9) simplifies to the generalised multivariate beta distribution, derived in Chapter 2 (see (2.8) with  $p = 2$ ):

$$f(u_0, u_1, u_2) = \frac{\lambda^{\frac{a}{2}} \Gamma\left(\frac{a+v_0+v_1+v_2}{2}\right)}{\Gamma\left(\frac{a}{2}\right)\Gamma\left(\frac{v_0}{2}\right)\Gamma\left(\frac{v_1}{2}\right)\Gamma\left(\frac{v_2}{2}\right)} u_0^{\frac{v_0}{2}-1} u_1^{\frac{v_1}{2}-1} u_2^{\frac{v_2}{2}-1} (1+u_0)^{\frac{v_1+v_2}{2}} (1+u_1)^{\frac{v_2}{2}} \\ \times [\lambda + u_0 + u_1(1+u_0) + u_2(1+u_0)(1+u_1)]^{-\left(\frac{a+v_0+v_1+v_2}{2}\right)}, \\ u_j > 0, j = 0, 1, 2.$$

#### 3.3.2 Marginal noncentral generalised beta type II distributions

**Theorem 3.2** Let  $X, W_i$  with  $i = 0, 1, 2$  be independent noncentral chi-squared random variables with degrees of freedom  $a$  and  $v_i$  and noncentrality parameters  $\delta_a$  and  $\delta_i$  with  $i = 0, 1, 2$ , respectively. Let  $U_0 = \frac{\lambda W_0}{X}$ ,  $U_1 = \frac{\lambda W_1}{X + \lambda W_0}$  and  $U_2 = \frac{\lambda W_2}{X + \lambda W_0 + \lambda W_1}$  and  $\lambda > 0$ .

(a) The joint pdf of  $(U_0, U_1)$  is given by

$$f(u_0, u_1) \tag{3.13} \\ = \frac{e^{-\left(\frac{\delta_a+\delta_0+\delta_1}{2}\right)} \lambda^{\frac{a}{2}} \Gamma\left(\frac{a+v_0+v_1}{2}\right)}{\Gamma\left(\frac{a}{2}\right)\Gamma\left(\frac{v_0}{2}\right)\Gamma\left(\frac{v_1}{2}\right)} u_0^{\frac{v_0}{2}-1} u_1^{\frac{v_1}{2}-1} (1+u_0)^{\frac{v_1}{2}} [\lambda + u_0 + u_1(1+u_0)]^{-\left(\frac{a+v_0+v_1}{2}\right)} \\ \times \Psi_2^{(3)} \left[ \frac{a+v_0+v_1}{2}; \frac{a}{2}, \frac{v_0}{2}, \frac{v_1}{2}; \frac{\lambda\delta_a}{2[\lambda+u_0+u_1(1+u_0)]}, \frac{\delta_0 u_0}{2[\lambda+u_0+u_1(1+u_0)]}, \frac{\delta_1 u_1(1+u_0)}{2[\lambda+u_0+u_1(1+u_0)]} \right], \\ u_j > 0, j = 0, 1,$$

with the values of the parameters such that  $f(u_0, u_1)$  is a valid pdf.

(b) The joint pdf of  $(U_0, U_2)$  is given by

$$f(u_0, u_2) \tag{3.14} \\ = \frac{e^{-\left(\frac{\delta_a+\delta_0+\delta_1+\delta_2}{2}\right)} \lambda^{\frac{a}{2}} \Gamma\left(\frac{a+v_0+v_1+v_2}{2}\right) \Gamma\left(\frac{a+v_0}{2}\right)}{\Gamma\left(\frac{a}{2}\right)\Gamma\left(\frac{v_0}{2}\right)\Gamma\left(\frac{v_2}{2}\right)\Gamma\left(\frac{a+v_0+v_1}{2}\right)} u_0^{\frac{v_0}{2}-1} (1+u_0)^{-\left(\frac{a+v_0}{2}\right)} u_2^{\frac{v_2}{2}-1} \\ \times (1+u_2)^{-\left(\frac{a+v_0+v_1+v_2}{2}\right)} \sum_{k_1=0}^{\infty} \sum_{k_2=0}^{\infty} \sum_{k_3=0}^{\infty} \sum_{k_4=0}^{\infty} \sum_{k_5=0}^{\infty} \frac{\left(\frac{a+v_0+v_1+v_2}{2}\right)_{k_1+k_2+k_3+k_4+k_5}}{\left(\frac{a}{2}\right)_{k_1} \left(\frac{v_0}{2}\right)_{k_2} \left(\frac{v_2}{2}\right)_{k_4}} \\ \times \frac{\left(\frac{a+v_0}{2}\right)_{k_1+k_2+k_5}}{\left(\frac{a+v_0+v_1}{2}\right)_{k_1+k_2+k_3+k_5}} \left(\frac{\lambda\delta_a}{2(1+u_0)(1+u_2)}\right)^{k_1} \\ \times \left(\frac{\delta_0 u_0}{2(1+u_0)(1+u_2)}\right)^{k_2} \left(\frac{\delta_1}{2(1+u_2)}\right)^{k_3} \left(\frac{\delta_2 u_2}{2(1+u_2)}\right)^{k_4} \left(\frac{1-\lambda}{(1+u_0)(1+u_2)}\right)^{k_5}, \\ u_j > 0, j = 0, 2,$$

### 3. NONCENTRAL GENERALISED MULTIVARIATE BETA TYPE II DISTRIBUTIONS

#### 3.3. The noncentral generalised trivariate beta type II distribution

with the values of the parameters such that  $f(u_0, u_2)$  is a valid pdf.

(c) The joint pdf of  $(U_1, U_2)$  is given by

$$\begin{aligned}
 f(u_1, u_2) & \quad (3.15) \\
 &= \frac{e^{-\left(\frac{\delta_a + \delta_0 + \delta_1 + \delta_2}{2}\right)} \lambda^{\frac{a}{2}} \Gamma\left(\frac{a+v_0+v_1+v_2}{2}\right)}{\Gamma\left(\frac{v_1}{2}\right)\Gamma\left(\frac{v_2}{2}\right)\Gamma\left(\frac{a+v_0}{2}\right)} u_1^{\frac{v_1}{2}-1} (1+u_1)^{-\left(\frac{a+v_0+v_1}{2}\right)} u_2^{\frac{v_2}{2}-1} \\
 &\times (1+u_2)^{-\left(\frac{a+v_0+v_1+v_2}{2}\right)} \sum_{k_1=0}^{\infty} \sum_{k_2=0}^{\infty} \sum_{k_3=0}^{\infty} \sum_{k_4=0}^{\infty} \sum_{k_5=0}^{\infty} \frac{\left(\frac{a+v_0+v_1+v_2}{2}\right)_{k_1+k_2+k_3+k_4+k_5}}{\left(\frac{a}{2}\right)_{k_1} \left(\frac{v_1}{2}\right)_{k_3} \left(\frac{v_2}{2}\right)_{k_4}} \\
 &\times \frac{\left(\frac{a}{2}\right)_{k_1+k_5}}{\left(\frac{a+v_0}{2}\right)_{k_1+k_2+k_5} k_1! k_2! k_3! k_4! k_5!} \left(\frac{\lambda \delta_a}{2(1+u_1)(1+u_2)}\right)^{k_1} \left(\frac{\delta_0}{2(1+u_1)(1+u_2)}\right)^{k_2} \\
 &\times \left(\frac{\delta_1 u_1}{2(1+u_1)(1+u_2)}\right)^{k_3} \left(\frac{\delta_2 u_2}{2(1+u_2)}\right)^{k_4} \left(\frac{1-\lambda}{(1+u_1)(1+u_2)}\right)^{k_5}, \\
 & \quad u_j > 0, \quad j = 1, 2,
 \end{aligned}$$

with the values of the parameters such that  $f(u_1, u_2)$  is a valid pdf.

**Proof.** (a) Expanding  $\Psi_2^{(4)}(\cdot)$  in (3.9) in series form (see (B.11)) and integrating this trivariate pdf with respect to  $u_2$ , yields

$$\begin{aligned}
 f(u_0, u_1) & \\
 &= \frac{e^{-\left(\frac{\delta_a + \delta_0 + \delta_1 + \delta_2}{2}\right)} \lambda^{\frac{a}{2}} \Gamma\left(\frac{a+v_0+v_1+v_2}{2}\right)}{\Gamma\left(\frac{a}{2}\right)\Gamma\left(\frac{v_0}{2}\right)\Gamma\left(\frac{v_1}{2}\right)\Gamma\left(\frac{v_2}{2}\right)} u_0^{\frac{v_0}{2}-1} u_1^{\frac{v_1}{2}-1} (1+u_0)^{\frac{v_1+v_2}{2}} (1+u_1)^{\frac{v_2}{2}} \\
 &\times \sum_{k_1=0}^{\infty} \sum_{k_2=0}^{\infty} \sum_{k_3=0}^{\infty} \sum_{k_4=0}^{\infty} \frac{\left(\frac{a+v_0+v_1+v_2}{2}\right)_{k_1+k_2+k_3+k_4}}{\left(\frac{a}{2}\right)_{k_1} \left(\frac{v_0}{2}\right)_{k_2} \left(\frac{v_1}{2}\right)_{k_3} \left(\frac{v_2}{2}\right)_{k_4} k_1! k_2! k_3! k_4!} \left(\frac{\lambda \delta_a}{2}\right)^{k_1} \\
 &\times \left(\frac{\delta_0 u_0}{2}\right)^{k_2} \left(\frac{\delta_1 u_1 (1+u_0)}{2}\right)^{k_3} \left(\frac{\delta_2 (1+u_0)(1+u_1)}{2}\right)^{k_4} \\
 &\times \int_0^{\frac{v_2}{2}+k_4-1} u_2^{\frac{v_2}{2}+k_4-1} [\lambda+u_0+u_1(1+u_0)+u_2(1+u_0)(1+u_1)]^{-\left(\frac{a+v_0+v_1+v_2}{2}+k_1+k_2+k_3+k_4\right)} du_2.
 \end{aligned} \quad (3.16)$$

Rewriting and solving the integral in (3.16) using (B.19) gives

$$\begin{aligned}
 &\int_0^{\frac{v_2}{2}+k_4-1} u_2^{\frac{v_2}{2}+k_4-1} [\lambda+u_0+u_1(1+u_0)+u_2(1+u_0)(1+u_1)]^{-\left(\frac{a+v_0+v_1+v_2}{2}+k_1+k_2+k_3+k_4\right)} du_2 \\
 &= [\lambda+u_0+u_1(1+u_0)]^{-\left(\frac{a+v_0+v_1+v_2}{2}+k_1+k_2+k_3+k_4\right)} \\
 &\times \int_0^{\frac{v_2}{2}+k_4-1} \left[1 + \frac{u_2(1+u_0)(1+u_1)}{\lambda+u_0+u_1(1+u_0)}\right]^{-\left(\frac{a+v_0+v_1+v_2}{2}+k_1+k_2+k_3+k_4\right)} du_2
 \end{aligned}$$

### 3. NONCENTRAL GENERALISED MULTIVARIATE BETA TYPE II DISTRIBUTIONS

#### 3.3. The noncentral generalised trivariate beta type II distribution

$$\begin{aligned}
 &= [\lambda + u_0 + u_1(1 + u_0)]^{-\left(\frac{a+v_0+v_1+v_2}{2} + k_1+k_2+k_3+k_4\right)} \\
 &\quad \times \left[ \frac{(1 + u_0)(1 + u_1)}{\lambda + u_0 + u_1(1 + u_0)} \right]^{-\left(\frac{v_2}{2} + k_4\right)} \frac{\Gamma\left(\frac{v_2}{2} + k_4\right) \Gamma\left(\frac{a}{2} + \frac{v_0}{2} + \frac{v_1}{2} + k_1 + k_2 + k_3\right)}{\Gamma\left(\frac{a}{2} + \frac{v_0}{2} + \frac{v_1}{2} + \frac{v_2}{2} + k_1 + k_2 + k_3 + k_4\right)} \\
 &= [\lambda + u_0 + u_1(1 + u_0)]^{-\left(\frac{a+v_0+v_1}{2} + k_1+k_2+k_3\right)} \tag{3.17} \\
 &\quad \times [(1 + u_0)(1 + u_1)]^{-\left(\frac{v_2}{2} + k_4\right)} \frac{\Gamma\left(\frac{v_2}{2} + k_4\right) \Gamma\left(\frac{a}{2} + \frac{v_0}{2} + \frac{v_1}{2} + k_1 + k_2 + k_3\right)}{\Gamma\left(\frac{a}{2} + \frac{v_0}{2} + \frac{v_1}{2} + \frac{v_2}{2} + k_1 + k_2 + k_3 + k_4\right)}.
 \end{aligned}$$

Substituting (3.17) in (3.16) gives

$$\begin{aligned}
 &f(u_0, u_1) \\
 &= \frac{e^{-\left(\frac{\delta_a + \delta_0 + \delta_1 + \delta_2}{2}\right)} \lambda^{\frac{a}{2}} \Gamma\left(\frac{a+v_0+v_1+v_2}{2}\right)}{\Gamma\left(\frac{a}{2}\right) \Gamma\left(\frac{v_0}{2}\right) \Gamma\left(\frac{v_1}{2}\right) \Gamma\left(\frac{v_2}{2}\right)} u_0^{\frac{v_0}{2}-1} u_1^{\frac{v_1}{2}-1} (1 + u_0)^{\frac{v_1}{2}} [\lambda + u_0 + u_1(1 + u_0)]^{-\left(\frac{a+v_0+v_1}{2}\right)} \\
 &\quad \times \sum_{k_1=0}^{\infty} \sum_{k_2=0}^{\infty} \sum_{k_3=0}^{\infty} \sum_{k_4=0}^{\infty} \frac{\left(\frac{a+v_0+v_1+v_2}{2}\right)_{k_1+k_2+k_3+k_4}}{\left(\frac{a}{2}\right)_{k_1} \left(\frac{v_0}{2}\right)_{k_2} \left(\frac{v_1}{2}\right)_{k_3} \left(\frac{v_2}{2}\right)_{k_4} k_1!k_2!k_3!k_4!} \left(\frac{\lambda \delta_a}{2[\lambda + u_0 + u_1(1 + u_0)]}\right)^{k_1} \\
 &\quad \times \left(\frac{\delta_0 u_0}{2[\lambda + u_0 + u_1(1 + u_0)]}\right)^{k_2} \left(\frac{\delta_1 u_1(1 + u_0)}{2[\lambda + u_0 + u_1(1 + u_0)]}\right)^{k_3} \left(\frac{\delta_2}{2}\right)^{k_4} \\
 &\quad \times \frac{\Gamma\left(\frac{v_2}{2} + k_4\right) \Gamma\left(\frac{a}{2} + \frac{v_0}{2} + \frac{v_1}{2} + k_1 + k_2 + k_3\right)}{\Gamma\left(\frac{a}{2} + \frac{v_0}{2} + \frac{v_1}{2} + \frac{v_2}{2} + k_1 + k_2 + k_3 + k_4\right)}.
 \end{aligned}$$

Rewriting the Pochhammer coefficients in terms of gamma functions, using (B.4) give

$$\begin{aligned}
 &f(u_0, u_1) \\
 &= \frac{e^{-\left(\frac{\delta_a + \delta_0 + \delta_1 + \delta_2}{2}\right)} \lambda^{\frac{a}{2}} \Gamma\left(\frac{a+v_0+v_1+v_2}{2}\right)}{\Gamma\left(\frac{a}{2}\right) \Gamma\left(\frac{v_0}{2}\right) \Gamma\left(\frac{v_1}{2}\right) \Gamma\left(\frac{v_2}{2}\right)} u_0^{\frac{v_0}{2}-1} u_1^{\frac{v_1}{2}-1} (1 + u_0)^{\frac{v_1}{2}} [\lambda + u_0 + u_1(1 + u_0)]^{-\left(\frac{a+v_0+v_1}{2}\right)} \\
 &\quad \times \sum_{k_1=0}^{\infty} \sum_{k_2=0}^{\infty} \sum_{k_3=0}^{\infty} \sum_{k_4=0}^{\infty} \frac{\Gamma\left(\frac{a}{2} + \frac{v_0}{2} + \frac{v_1}{2} + \frac{v_2}{2} + k_1 + k_2 + k_3 + k_4\right) \Gamma\left(\frac{v_2}{2}\right)}{\Gamma\left(\frac{a}{2} + \frac{v_0}{2} + \frac{v_1}{2} + \frac{v_2}{2}\right) \left(\frac{a}{2}\right)_{k_1} \left(\frac{v_0}{2}\right)_{k_2} \left(\frac{v_1}{2}\right)_{k_3} \Gamma\left(\frac{v_2}{2} + k_4\right) k_1!k_2!k_3!k_4!} \\
 &\quad \times \left(\frac{\lambda \delta_a}{2[\lambda + u_0 + u_1(1 + u_0)]}\right)^{k_1} \left(\frac{\delta_0 u_0}{2[\lambda + u_0 + u_1(1 + u_0)]}\right)^{k_2} \left(\frac{\delta_1 u_1(1 + u_0)}{2[\lambda + u_0 + u_1(1 + u_0)]}\right)^{k_3} \\
 &\quad \times \left(\frac{\delta_2}{2}\right)^{k_4} \frac{\Gamma\left(\frac{v_2}{2} + k_4\right) \Gamma\left(\frac{a}{2} + \frac{v_0}{2} + \frac{v_1}{2} + k_1 + k_2 + k_3\right)}{\Gamma\left(\frac{a}{2} + \frac{v_0}{2} + \frac{v_1}{2} + \frac{v_2}{2} + k_1 + k_2 + k_3 + k_4\right)}
 \end{aligned}$$

### 3. NONCENTRAL GENERALISED MULTIVARIATE BETA TYPE II DISTRIBUTIONS

#### 3.3. The noncentral generalised trivariate beta type II distribution

$$\begin{aligned}
&= \frac{e^{-\left(\frac{\delta_a + \delta_0 + \delta_1 + \delta_2}{2}\right)} \Gamma\left(\frac{a}{2} + \frac{v_0}{2} + \frac{v_1}{2}\right) \lambda^{\frac{a}{2}}}{\Gamma\left(\frac{a}{2}\right) \Gamma\left(\frac{v_0}{2}\right) \Gamma\left(\frac{v_1}{2}\right)} u_0^{\frac{v_0}{2}-1} u_1^{\frac{v_1}{2}-1} (1+u_0)^{\frac{v_1}{2}} [\lambda + u_0 + u_1(1+u_0)]^{-\left(\frac{a+v_0+v_1}{2}\right)} \\
&\times \sum_{k_1=0}^{\infty} \sum_{k_2=0}^{\infty} \sum_{k_3=0}^{\infty} \frac{\left(\frac{a}{2} + \frac{v_0}{2} + \frac{v_1}{2}\right)_{k_1+k_2+k_3}}{\left(\frac{a}{2}\right)_{k_1} \left(\frac{v_0}{2}\right)_{k_2} \left(\frac{v_1}{2}\right)_{k_3} k_1! k_2! k_3!} \\
&\times \left(\frac{\lambda \delta_a}{2[\lambda + u_0 + u_1(1+u_0)]}\right)^{k_1} \left(\frac{\delta_0 u_0}{2[\lambda + u_0 + u_1(1+u_0)]}\right)^{k_2} \left(\frac{\delta_1 u_1(1+u_0)}{2[\lambda + u_0 + u_1(1+u_0)]}\right)^{k_3} \\
&\times \sum_{k_4=0}^{\infty} \frac{\left(\frac{\delta_2}{2}\right)^{k_4}}{k_4!}.
\end{aligned}$$

Subsequently, the joint pdf of  $U_0$  and  $U_1$  in (3.13) follows by applying (B.6) and (B.11).

(b) Expanding  $\Psi_2^{(4)}(\cdot)$  in (3.9) in series form using (B.11) and integrating the trivariate pdf (3.9) with respect to  $u_1$ , it follows that

$$\begin{aligned}
&f(u_0, u_2) \\
&= \frac{e^{-\left(\frac{\delta_a + \delta_0 + \delta_1 + \delta_2}{2}\right)} \lambda^{\frac{a}{2}} \Gamma\left(\frac{a+v_0+v_1+v_2}{2}\right)}{\Gamma\left(\frac{a}{2}\right) \Gamma\left(\frac{v_0}{2}\right) \Gamma\left(\frac{v_1}{2}\right) \Gamma\left(\frac{v_2}{2}\right)} u_0^{\frac{v_0}{2}-1} (1+u_0)^{\frac{v_1+v_2}{2}} u_2^{\frac{v_2}{2}-1} \\
&\times \sum_{k_1=0}^{\infty} \sum_{k_2=0}^{\infty} \sum_{k_3=0}^{\infty} \sum_{k_4=0}^{\infty} \frac{\left(\frac{a+v_0+v_1+v_2}{2}\right)_{k_1+k_2+k_3+k_4}}{\left(\frac{a}{2}\right)_{k_1} \left(\frac{v_0}{2}\right)_{k_2} \left(\frac{v_1}{2}\right)_{k_3} \left(\frac{v_2}{2}\right)_{k_4} k_1! k_2! k_3! k_4!} \left(\frac{\lambda \delta_a}{2}\right)^{k_1} \left(\frac{\delta_0 u_0}{2}\right)^{k_2} \\
&\times \left(\frac{\delta_1(1+u_0)}{2}\right)^{k_3} \left(\frac{\delta_2 u_2(1+u_0)}{2}\right)^{k_4} \int_0^{\infty} u_1^{\frac{v_1}{2}+k_3-1} (1+u_1)^{\frac{v_2}{2}+k_4} \\
&\times [\lambda + u_0 + u_1(1+u_0) + u_2(1+u_0)(1+u_1)]^{-\left(\frac{a+v_0+v_1+v_2}{2} + k_1+k_2+k_3+k_4\right)} du_1.
\end{aligned} \tag{3.18}$$

Solving the integral in (3.18) using (B.20) gives

$$\begin{aligned}
&\int_0^{\infty} u_1^{\frac{v_1}{2}+k_3-1} (1+u_1)^{\frac{v_2}{2}+k_4} [\lambda + u_0 + u_1(1+u_0) + u_2(1+u_0)(1+u_1)]^{-\left(\frac{a+v_0+v_1+v_2}{2} + k_1+k_2+k_3+k_4\right)} du_1 \\
&= \int_0^{\infty} u_1^{\frac{v_1}{2}+k_3-1} (1+u_1)^{\frac{v_2}{2}+k_4} [\lambda + u_0 + u_2(1+u_0) + u_1(1+u_0)(1+u_2)]^{-\left(\frac{a+v_0+v_1+v_2}{2} + k_1+k_2+k_3+k_4\right)} du_1
\end{aligned}$$

### 3. NONCENTRAL GENERALISED MULTIVARIATE BETA TYPE II DISTRIBUTIONS

#### 3.3. The noncentral generalised trivariate beta type II distribution

$$\begin{aligned}
&= [\lambda + u_0 + u_2(1 + u_0)]^{-\left(\frac{a+v_0+v_1+v_2}{2}+k_1+k_2+k_3+k_4\right)} \\
&\quad \times \int_0^\infty u_1^{\frac{v_1}{2}+k_3-1} (1 + u_1)^{\frac{v_2}{2}+k_4} \left[1 + \frac{u_1(1+u_0)(1+u_2)}{\lambda+u_0+u_2(1+u_0)}\right]^{-\left(\frac{a+v_0+v_1+v_2}{2}+k_1+k_2+k_3+k_4\right)} du_1 \\
&= [\lambda + u_0 + u_2(1 + u_0)]^{-\left(\frac{a+v_0+v_1+v_2}{2}+k_1+k_2+k_3+k_4\right)} \\
&\quad \times \frac{\Gamma\left(\frac{v_1}{2} + k_3\right) \Gamma\left(\frac{a+v_0}{2} + k_1 + k_2\right)}{\Gamma\left(\frac{a+v_0+v_1}{2} + k_1 + k_2 + k_3\right)} \\
&\quad \times {}_2F_1\left(\frac{a+v_0+v_1+v_2}{2}+k_1+k_2+k_3+k_4, \frac{v_1}{2}+k_3; \frac{a+v_0+v_1}{2}+k_1+k_2+k_3; 1 - \frac{(1+u_0)(1+u_2)}{\lambda+u_0+u_2(1+u_0)}\right) \\
&= [(1 + u_0)(1 + u_2)]^{-\left(\frac{a+v_0+v_1+v_2}{2}+k_1+k_2+k_3+k_4\right)} \frac{\Gamma\left(\frac{v_1}{2} + k_3\right) \Gamma\left(\frac{a+v_0}{2} + k_1 + k_2\right)}{\Gamma\left(\frac{a+v_0+v_1}{2} + k_1 + k_2 + k_3\right)} \quad (3.19) \\
&\quad \times {}_2F_1\left(\frac{a+v_0+v_1+v_2}{2}+k_1+k_2+k_3+k_4, \frac{a+v_0}{2}+k_1+k_2; \frac{a+v_0+v_1}{2}+k_1+k_2+k_3; \frac{1-\lambda}{(1+u_0)(1+u_2)}\right).
\end{aligned}$$

The latter step follows by using (B.24) with

$$x = 1 - \frac{(1 + u_0)(1 + u_2)}{\lambda + u_0 + u_2(1 + u_0)} = \frac{\lambda - 1}{\lambda + u_0 + u_2(1 + u_0)}.$$

Substituting (3.19) in (3.18) gives

$$\begin{aligned}
&f(u_0, u_2) \\
&= \frac{e^{-\left(\frac{\delta_a+\delta_0+\delta_1+\delta_2}{2}\right)} \lambda^{\frac{a}{2}} \Gamma\left(\frac{a+v_0+v_1+v_2}{2}\right) u_0^{\frac{v_0}{2}-1} (1 + u_0)^{-\left(\frac{a+v_0}{2}\right)} u_2^{\frac{v_2}{2}-1} (1 + u_2)^{-\left(\frac{a+v_0+v_1+v_2}{2}\right)}}{\Gamma\left(\frac{a}{2}\right) \Gamma\left(\frac{v_0}{2}\right) \Gamma\left(\frac{v_1}{2}\right) \Gamma\left(\frac{v_2}{2}\right)} \\
&\quad \times \sum_{k_1=0}^\infty \sum_{k_2=0}^\infty \sum_{k_3=0}^\infty \sum_{k_4=0}^\infty \frac{\left(\frac{a+v_0+v_1+v_2}{2}\right)_{k_1+k_2+k_3+k_4}}{\left(\frac{a}{2}\right)_{k_1} \left(\frac{v_0}{2}\right)_{k_2} \left(\frac{v_1}{2}\right)_{k_3} \left(\frac{v_2}{2}\right)_{k_4} k_1!k_2!k_3!k_4!} \left(\frac{\lambda\delta_a}{2(1 + u_0)(1 + u_2)}\right)^{k_1} \\
&\quad \times \left(\frac{\delta_0 u_0}{2(1 + u_0)(1 + u_2)}\right)^{k_2} \left(\frac{\delta_1}{2(1 + u_2)}\right)^{k_3} \left(\frac{\delta_2 u_2}{2(1 + u_2)}\right)^{k_4} \\
&\quad \times \frac{\Gamma\left(\frac{v_1}{2} + k_3\right) \Gamma\left(\frac{a+v_0}{2} + k_1 + k_2\right)}{\Gamma\left(\frac{a+v_0+v_1}{2} + k_1 + k_2 + k_3\right)} \\
&\quad \times {}_2F_1\left(\frac{a+v_0+v_1+v_2}{2}+k_1+k_2+k_3+k_4, \frac{a+v_0}{2}+k_1+k_2; \frac{a+v_0+v_1}{2}+k_1+k_2+k_3; \frac{1-\lambda}{(1+u_0)(1+u_2)}\right).
\end{aligned}$$

Replacing some of the Pochhammer coefficients with gamma functions (see (B.4)) and expanding  ${}_2F_1(\cdot)$  (see (B.5)) in series form, the desired result (3.14) follows after simplification,

### 3. NONCENTRAL GENERALISED MULTIVARIATE BETA TYPE II DISTRIBUTIONS

#### 3.3. The noncentral generalised trivariate beta type II distribution

$$\begin{aligned}
& f(u_0, u_2) \\
&= \frac{e^{-\left(\frac{\delta_a + \delta_0 + \delta_1 + \delta_2}{2}\right)} \lambda^{\frac{a}{2}} \Gamma\left(\frac{a+v_0+v_1+v_2}{2}\right)}{\Gamma\left(\frac{a}{2}\right)\Gamma\left(\frac{v_0}{2}\right)\Gamma\left(\frac{v_1}{2}\right)\Gamma\left(\frac{v_2}{2}\right)} u_0^{\frac{v_0}{2}-1} (1+u_0)^{-\left(\frac{a+v_0}{2}\right)} u_2^{\frac{v_2}{2}-1} (1+u_2)^{-\left(\frac{a+v_0+v_1+v_2}{2}\right)} \\
&\times \sum_{k_1=0}^{\infty} \sum_{k_2=0}^{\infty} \sum_{k_3=0}^{\infty} \sum_{k_4=0}^{\infty} \frac{\Gamma\left(\frac{a+v_0+v_1+v_2}{2} + k_1 + k_2 + k_3 + k_4\right) \Gamma\left(\frac{v_1}{2}\right)}{\Gamma\left(\frac{a+v_0+v_1+v_2}{2}\right) \left(\frac{a}{2}\right)_{k_1} \left(\frac{v_0}{2}\right)_{k_2} \Gamma\left(\frac{v_1}{2} + k_3\right) \left(\frac{v_2}{2}\right)_{k_4} k_1!k_2!k_3!k_4!} \\
&\times \left(\frac{\lambda\delta_a}{2(1+u_0)(1+u_2)}\right)^{k_1} \left(\frac{\delta_0 u_0}{2(1+u_0)(1+u_2)}\right)^{k_2} \left(\frac{\delta_1}{2(1+u_2)}\right)^{k_3} \left(\frac{\delta_2 u_2}{2(1+u_2)}\right)^{k_4} \\
&\times \frac{\Gamma\left(\frac{v_1}{2} + k_3\right) \Gamma\left(\frac{a+v_0}{2} + k_1 + k_2\right)}{\Gamma\left(\frac{a+v_0+v_1}{2} + k_1 + k_2 + k_3\right)} \\
&\times \sum_{k_5=0}^{\infty} \frac{\Gamma\left(\frac{a+v_0+v_1+v_2}{2} + k_1 + k_2 + k_3 + k_4 + k_5\right) \Gamma\left(\frac{a+v_0}{2} + k_1 + k_2 + k_5\right) \Gamma\left(\frac{a+v_0+v_1}{2} + k_1 + k_2 + k_3\right)}{\Gamma\left(\frac{a+v_0+v_1+v_2}{2} + k_1 + k_2 + k_3 + k_4\right) \Gamma\left(\frac{a+v_0}{2} + k_1 + k_2\right) \Gamma\left(\frac{a+v_0+v_1}{2} + k_1 + k_2 + k_3 + k_5\right) k_5!} \\
&\times \left(\frac{1-\lambda}{(1+u_0)(1+u_2)}\right)^{k_5} \\
&= \frac{e^{-\left(\frac{\delta_a + \delta_0 + \delta_1 + \delta_2}{2}\right)} \lambda^{\frac{a}{2}} \Gamma\left(\frac{a+v_0+v_1+v_2}{2}\right)}{\Gamma\left(\frac{a}{2}\right)\Gamma\left(\frac{v_0}{2}\right)\Gamma\left(\frac{v_2}{2}\right)} u_0^{\frac{v_0}{2}-1} (1+u_0)^{-\left(\frac{a+v_0}{2}\right)} u_2^{\frac{v_2}{2}-1} (1+u_2)^{-\left(\frac{a+v_0+v_1+v_2}{2}\right)} \\
&\times \sum_{k_1=0}^{\infty} \sum_{k_2=0}^{\infty} \sum_{k_3=0}^{\infty} \sum_{k_4=0}^{\infty} \sum_{k_5=0}^{\infty} \frac{\Gamma\left(\frac{a+v_0+v_1+v_2}{2} + k_1 + k_2 + k_3 + k_4 + k_5\right) \Gamma\left(\frac{a+v_0}{2} + k_1 + k_2 + k_5\right)}{\Gamma\left(\frac{a+v_0+v_1+v_2}{2}\right) \Gamma\left(\frac{a+v_0+v_1}{2} + k_1 + k_2 + k_3 + k_5\right) \left(\frac{a}{2}\right)_{k_1} \left(\frac{v_0}{2}\right)_{k_2} \left(\frac{v_2}{2}\right)_{k_4}} \\
&\times \frac{1}{k_1!k_2!k_3!k_4!k_5!} \left(\frac{\lambda\delta_a}{2(1+u_0)(1+u_2)}\right)^{k_1} \left(\frac{\delta_0 u_0}{2(1+u_0)(1+u_2)}\right)^{k_2} \left(\frac{\delta_1}{2(1+u_2)}\right)^{k_3} \\
&\times \left(\frac{\delta_2 u_2}{2(1+u_2)}\right)^{k_4} \left(\frac{1-\lambda}{(1+u_0)(1+u_2)}\right)^{k_5} \\
&= \frac{e^{-\left(\frac{\delta_a + \delta_0 + \delta_1 + \delta_2}{2}\right)} \lambda^{\frac{a}{2}} \Gamma\left(\frac{a+v_0+v_1+v_2}{2}\right) \Gamma\left(\frac{a+v_0}{2}\right)}{\Gamma\left(\frac{a}{2}\right)\Gamma\left(\frac{v_0}{2}\right)\Gamma\left(\frac{v_2}{2}\right)\Gamma\left(\frac{a+v_0+v_1}{2}\right)} u_0^{\frac{v_0}{2}-1} (1+u_0)^{-\left(\frac{a+v_0}{2}\right)} u_2^{\frac{v_2}{2}-1} (1+u_2)^{-\left(\frac{a+v_0+v_1+v_2}{2}\right)} \\
&\times \sum_{k_1=0}^{\infty} \sum_{k_2=0}^{\infty} \sum_{k_3=0}^{\infty} \sum_{k_4=0}^{\infty} \sum_{k_5=0}^{\infty} \frac{\left(\frac{a+v_0+v_1+v_2}{2}\right)_{k_1+k_2+k_3+k_4+k_5} \left(\frac{a+v_0}{2}\right)_{k_1+k_2+k_5}}{\left(\frac{a}{2}\right)_{k_1} \left(\frac{v_0}{2}\right)_{k_2} \left(\frac{v_2}{2}\right)_{k_4} \left(\frac{a+v_0+v_1}{2}\right)_{k_1+k_2+k_3+k_5} k_1!k_2!k_3!k_4!k_5!} \\
&\times \left(\frac{\lambda\delta_a}{2(1+u_0)(1+u_2)}\right)^{k_1} \left(\frac{\delta_0 u_0}{2(1+u_0)(1+u_2)}\right)^{k_2} \left(\frac{\delta_1}{2(1+u_2)}\right)^{k_3} \left(\frac{\delta_2 u_2}{2(1+u_2)}\right)^{k_4} \\
&\times \left(\frac{1-\lambda}{(1+u_0)(1+u_2)}\right)^{k_5}.
\end{aligned}$$

(c) Proof follows similarly as in (b). ■

**Remark 3.4** (i) Alternatively, the proof of Theorem 3.2(a) can be derived by substituting  $p=1$  in (3.28) in Section 3.4.



### 3. NONCENTRAL GENERALISED MULTIVARIATE BETA TYPE II DISTRIBUTIONS

#### 3.3. The noncentral generalised trivariate beta type II distribution

---

(ii) Substituting  $\delta_a = \delta_0 = \delta_1 = 0$  in (3.13), the pdf simplifies to the bivariate distribution derived in Chapter 2 (see (2.38)),

$$\begin{aligned}
 & f(u_0, u_1) \\
 &= \frac{\lambda^{\frac{a}{2}} \Gamma\left(\frac{a+v_0+v_1}{2}\right)}{\Gamma\left(\frac{a}{2}\right)\Gamma\left(\frac{v_0}{2}\right)\Gamma\left(\frac{v_1}{2}\right)} u_0^{\frac{v_0}{2}-1} (1+u_0)^{-\left(\frac{a+v_0}{2}\right)} u_1^{\frac{v_1}{2}-1} (1+u_1)^{-\left(\frac{a+v_0+v_1}{2}\right)} \\
 & \times \left[ \frac{\lambda + u_0 + u_1(1+u_0)}{(1+u_0)(1+u_1)} \right]^{-\left(\frac{a+v_0+v_1}{2}\right)}, \\
 & \qquad \qquad \qquad u_j > 0, j = 0, 1.
 \end{aligned}$$

This can be rewritten using the binomial series (B.7) with  $1 - z = \frac{\lambda + u_0 + u_1(1+u_0)}{(1+u_0)(1+u_1)}$ . Therefore,

$$\begin{aligned}
 & f(u_0, u_1) \\
 &= \frac{\Gamma\left(\frac{a+v_0+v_1}{2}\right) \lambda^{\frac{a}{2}}}{\Gamma\left(\frac{a}{2}\right)\Gamma\left(\frac{v_0}{2}\right)\Gamma\left(\frac{v_1}{2}\right)} u_0^{\frac{v_0}{2}-1} (1+u_0)^{-\left(\frac{a+v_0}{2}\right)} u_1^{\frac{v_1}{2}-1} (1+u_1)^{-\left(\frac{a+v_0+v_1}{2}\right)} \\
 & \times {}_1F_0\left(\frac{a+v_0+v_1}{2}; \frac{1-\lambda}{(1+u_0)(1+u_1)}\right), \\
 & \qquad \qquad \qquad u_j > 0, j = 0, 1, \frac{1-\lambda}{(1+u_0)(1+u_1)} < 1.
 \end{aligned}$$

**Theorem 3.3** Let  $X, W_i$  with  $i = 0, 1, 2$  be independent noncentral chi-squared random variables with degrees of freedom  $a$  and  $v_i$  and noncentrality parameters  $\delta_a$  and  $\delta_i$  with  $i = 0, 1, 2$ , respectively. Let  $U_0 = \frac{\lambda W_0}{X}$ ,  $U_1 = \frac{\lambda W_1}{X + \lambda W_0}$  and  $U_2 = \frac{\lambda W_2}{X + \lambda W_0 + \lambda W_1}$  and  $\lambda > 0$ . The marginal pdf of

(a)  $U_0$  is given by

$$\begin{aligned}
 & f(u_0) \\
 &= \frac{e^{-\left(\frac{\delta_a + \delta_0}{2}\right)} \lambda^{\frac{a}{2}} \Gamma\left(\frac{a+v_0}{2}\right)}{\Gamma\left(\frac{a}{2}\right)\Gamma\left(\frac{v_0}{2}\right)} u_0^{\frac{v_0}{2}-1} (u_0 + \lambda)^{-\left(\frac{a+v_0}{2}\right)} \Psi_2\left(\frac{a+v_0}{2}; \frac{a}{2}, \frac{v_0}{2}; \frac{\lambda \delta_a}{2(u_0 + \lambda)}, \frac{\delta_0 u_0}{2(u_0 + \lambda)}\right), \quad (3.20) \\
 & \qquad \qquad \qquad u_0 > 0,
 \end{aligned}$$

with  $\Psi_2$  the Humbert confluent hypergeometric function of two variables (see (B.13)) with the values of the parameters such that  $f(u_0)$  is a valid pdf.

### 3. NONCENTRAL GENERALISED MULTIVARIATE BETA TYPE II DISTRIBUTIONS

#### 3.3. The noncentral generalised trivariate beta type II distribution

(b)  $U_1$  is given by

$$\begin{aligned}
 & f(u_1) \\
 &= \frac{e^{-\left(\frac{\delta_a + \delta_0 + \delta_1}{2}\right)} \lambda^{\frac{a}{2}} \Gamma\left(\frac{a+v_0+v_1}{2}\right)}{\Gamma\left(\frac{v_1}{2}\right) \Gamma\left(\frac{a+v_0}{2}\right)} u_1^{\frac{v_1}{2}-1} (1+u_1)^{-\left(\frac{a+v_0+v_1}{2}\right)} \\
 & \times \sum_{k_1=0}^{\infty} \sum_{k_2=0}^{\infty} \sum_{k_3=0}^{\infty} \sum_{k_5=0}^{\infty} \frac{\left(\frac{a+v_0+v_1}{2}\right)_{k_1+k_2+k_3+k_5} \left(\frac{a}{2}\right)_{k_1+k_5}}{\left(\frac{a}{2}\right)_{k_1} \left(\frac{v_1}{2}\right)_{k_3} \left(\frac{a+v_0}{2}\right)_{k_1+k_2+k_5} k_1! k_2! k_3! k_5!} \\
 & \times \left(\frac{\lambda \delta_a}{2(1+u_1)}\right)^{k_1} \left(\frac{\delta_0}{2(1+u_1)}\right)^{k_2} \left(\frac{\delta_1 u_1}{2(1+u_1)}\right)^{k_3} \left(\frac{1-\lambda}{1+u_1}\right)^{k_5}, \\
 & \qquad \qquad \qquad u_1 > 0,
 \end{aligned} \tag{3.21}$$

with the values of the parameters such that  $f(u_1)$  is a valid pdf.

(c)  $U_2$  is given by

$$\begin{aligned}
 & f(u_2) \\
 &= \frac{e^{-\left(\frac{\delta_a + \delta_0 + \delta_1 + \delta_2}{2}\right)} \lambda^{\frac{a}{2}} \Gamma\left(\frac{a+v_0+v_1+v_2}{2}\right)}{\Gamma\left(\frac{v_2}{2}\right) \Gamma\left(\frac{a+v_0+v_1}{2}\right)} u_2^{\frac{v_2}{2}-1} (1+u_2)^{-\left(\frac{a+v_0+v_1+v_2}{2}\right)} \\
 & \times \sum_{k_1=0}^{\infty} \sum_{k_2=0}^{\infty} \sum_{k_3=0}^{\infty} \sum_{k_4=0}^{\infty} \sum_{k_5=0}^{\infty} \frac{\left(\frac{a+v_0+v_1+v_2}{2}\right)_{k_1+k_2+k_3+k_4+k_5} \left(\frac{a}{2}\right)_{k_1+k_5}}{\left(\frac{a}{2}\right)_{k_1} \left(\frac{v_2}{2}\right)_{k_4} \left(\frac{a+v_0+v_1}{2}\right)_{k_1+k_2+k_3+k_5} k_1! k_2! k_3! k_4! k_5!} \\
 & \times \left(\frac{\lambda \delta_a}{2(1+u_2)}\right)^{k_1} \left(\frac{\delta_0}{2(1+u_2)}\right)^{k_2} \left(\frac{\delta_1}{2(1+u_2)}\right)^{k_3} \left(\frac{\delta_2 u_2}{2(1+u_2)}\right)^{k_4} \left(\frac{1-\lambda}{(1+u_2)}\right)^{k_5}, \\
 & \qquad \qquad \qquad u_2 > 0,
 \end{aligned} \tag{3.22}$$

with the values of the parameters such that  $f(u_2)$  is a valid pdf.

**Proof.** (a) Expanding  $\Psi_2^{(3)}(\cdot)$  in (3.13) in series form using (B.11) and integrating with respect to  $u_1$ , gives

$$\begin{aligned}
 & f(u_0) \\
 &= \frac{e^{-\left(\frac{\delta_a + \delta_0 + \delta_1}{2}\right)} \lambda^{\frac{a}{2}} \Gamma\left(\frac{a+v_0+v_1}{2}\right)}{\Gamma\left(\frac{a}{2}\right) \Gamma\left(\frac{v_0}{2}\right) \Gamma\left(\frac{v_1}{2}\right)} u_0^{\frac{v_0}{2}-1} (1+u_0)^{\frac{v_1}{2}} \int_0^{\infty} u_1^{\frac{v_1}{2}-1} [\lambda + u_0 + u_1(1+u_0)]^{-\left(\frac{a+v_0+v_1}{2}\right)} \\
 & \times \sum_{k_1=0}^{\infty} \sum_{k_2=0}^{\infty} \sum_{k_3=0}^{\infty} \frac{\left(\frac{a+v_0+v_1}{2}\right)_{k_1+k_2+k_3}}{\left(\frac{a}{2}\right)_{k_1} \left(\frac{v_0}{2}\right)_{k_2} \left(\frac{v_1}{2}\right)_{k_3} k_1! k_2! k_3!} \left(\frac{\lambda \delta_a}{2[\lambda + u_0 + u_1(1+u_0)]}\right)^{k_1} \\
 & \times \left(\frac{\delta_0 u_0}{2[\lambda + u_0 + u_1(1+u_0)]}\right)^{k_2} \left(\frac{\delta_1 u_1(1+u_0)}{2[\lambda + u_0 + u_1(1+u_0)]}\right)^{k_3} du_1
 \end{aligned}$$

### 3. NONCENTRAL GENERALISED MULTIVARIATE BETA TYPE II DISTRIBUTIONS

#### 3.3. The noncentral generalised trivariate beta type II distribution

$$\begin{aligned}
&= \frac{e^{-\left(\frac{\delta_a + \delta_0 + \delta_1}{2}\right)} \lambda^{\frac{a}{2}} \Gamma\left(\frac{a+v_0+v_1}{2}\right) u_0^{\frac{v_0}{2}-1} (1+u_0)^{\frac{v_1}{2}} \int_0^\infty u_1^{\frac{v_1}{2}-1} \left[ (\lambda+u_0) \left( 1 + \frac{u_1(1+u_0)}{(\lambda+u_0)} \right) \right]^{-\left(\frac{a+v_0+v_1}{2}\right)}}{\Gamma\left(\frac{a}{2}\right) \Gamma\left(\frac{v_0}{2}\right) \Gamma\left(\frac{v_1}{2}\right)} \\
&\times \sum_{k_1=0}^\infty \sum_{k_2=0}^\infty \sum_{k_3=0}^\infty \frac{\left(\frac{a+v_0+v_1}{2}\right)_{k_1+k_2+k_3}}{\left(\frac{a}{2}\right)_{k_1} \left(\frac{v_0}{2}\right)_{k_2} \left(\frac{v_1}{2}\right)_{k_3} k_1! k_2! k_3!} \left( \frac{\lambda \delta_a}{2 \left[ (\lambda+u_0) \left( 1 + \frac{u_1(1+u_0)}{(\lambda+u_0)} \right) \right]} \right)^{k_1} \\
&\times \left( \frac{\delta_0 u_0}{2 \left[ (\lambda+u_0) \left( 1 + \frac{u_1(1+u_0)}{(\lambda+u_0)} \right) \right]} \right)^{k_2} \left( \frac{\delta_1 u_1 (1+u_0)}{2 \left[ (\lambda+u_0) \left( 1 + \frac{u_1(1+u_0)}{(\lambda+u_0)} \right) \right]} \right)^{k_3} du_1 \\
&= \frac{e^{-\left(\frac{\delta_a + \delta_0 + \delta_1}{2}\right)} \lambda^{\frac{a}{2}} \Gamma\left(\frac{a+v_0+v_1}{2}\right) u_0^{\frac{v_0}{2}-1} (1+u_0)^{\frac{v_1}{2}} (\lambda+u_0)^{-\left(\frac{a+v_0+v_1}{2}\right)}}{\Gamma\left(\frac{a}{2}\right) \Gamma\left(\frac{v_0}{2}\right) \Gamma\left(\frac{v_1}{2}\right)} \\
&\times \sum_{k_1=0}^\infty \sum_{k_2=0}^\infty \sum_{k_3=0}^\infty \frac{\left(\frac{a+v_0+v_1}{2}\right)_{k_1+k_2+k_3}}{\left(\frac{a}{2}\right)_{k_1} \left(\frac{v_0}{2}\right)_{k_2} \left(\frac{v_1}{2}\right)_{k_3} k_1! k_2! k_3!} \left( \frac{\lambda \delta_a}{2(\lambda+u_0)} \right)^{k_1} \\
&\times \left( \frac{\delta_0 u_0}{2(\lambda+u_0)} \right)^{k_2} \left( \frac{\delta_1 (1+u_0)}{2(\lambda+u_0)} \right)^{k_3} \int_0^\infty u_1^{\frac{v_1}{2}+k_3-1} \left( 1 + \frac{u_1(1+u_0)}{(\lambda+u_0)} \right)^{-\left(\frac{a+v_0+v_1}{2}+k_1+k_2+k_3\right)} du_1.
\end{aligned} \tag{3.23}$$

Solving the integral in (3.23) using (B.19) and (B.3) gives

$$\begin{aligned}
&\int_0^\infty u_1^{\frac{v_1}{2}+k_3-1} \left( 1 + \frac{u_1(1+u_0)}{(\lambda+u_0)} \right)^{-\left(\frac{a+v_0+v_1}{2}+k_1+k_2+k_3\right)} du_1 \\
&= \left( \frac{1+u_0}{\lambda+u_0} \right)^{-\left(\frac{v_1}{2}+k_3\right)} \frac{\Gamma\left(\frac{v_1}{2}+k_3\right) \Gamma\left(\frac{a+v_0}{2}+k_1+k_2\right)}{\Gamma\left(\frac{a+v_0+v_1}{2}+k_1+k_2+k_3\right)}.
\end{aligned} \tag{3.24}$$

Substituting (3.24) in (3.23) and using (B.4),

$$\begin{aligned}
&f(u_0) \\
&= \frac{e^{-\left(\frac{\delta_a + \delta_0 + \delta_1}{2}\right)} \lambda^{\frac{a}{2}} \Gamma\left(\frac{a+v_0+v_1}{2}\right) u_0^{\frac{v_0}{2}-1} (\lambda+u_0)^{-\left(\frac{a+v_0}{2}\right)}}{\Gamma\left(\frac{a}{2}\right) \Gamma\left(\frac{v_0}{2}\right) \Gamma\left(\frac{v_1}{2}\right)} \\
&\times \sum_{k_1=0}^\infty \sum_{k_2=0}^\infty \sum_{k_3=0}^\infty \frac{\Gamma\left(\frac{a+v_0+v_1}{2}+k_1+k_2+k_3\right) \Gamma\left(\frac{v_1}{2}\right)}{\left(\frac{a}{2}\right)_{k_1} \left(\frac{v_0}{2}\right)_{k_2} \Gamma\left(\frac{v_1}{2}+k_3\right) \Gamma\left(\frac{a+v_0+v_1}{2}\right) k_1! k_2! k_3!} \left( \frac{\lambda \delta_a}{2(\lambda+u_0)} \right)^{k_1} \\
&\times \left( \frac{\delta_0 u_0}{2(\lambda+u_0)} \right)^{k_2} \left( \frac{\delta_1}{2} \right)^{k_3} \frac{\Gamma\left(\frac{v_1}{2}+k_3\right) \Gamma\left(\frac{a+v_0}{2}+k_1+k_2\right)}{\Gamma\left(\frac{a+v_0+v_1}{2}+k_1+k_2+k_3\right)}
\end{aligned}$$

### 3. NONCENTRAL GENERALISED MULTIVARIATE BETA TYPE II DISTRIBUTIONS

#### 3.3. The noncentral generalised trivariate beta type II distribution

---

$$\begin{aligned}
 &= \frac{e^{-\left(\frac{\delta_a + \delta_0 + \delta_1}{2}\right)} \lambda^{\frac{a}{2}} \Gamma\left(\frac{a+v_0}{2}\right) u_0^{\frac{v_0}{2}-1} (\lambda + u_0)^{-\left(\frac{a+v_0}{2}\right)} \sum_{k_3=0}^{\infty} \frac{\left(\frac{\delta_1}{2}\right)^{k_3}}{k_3!}}{\Gamma\left(\frac{a}{2}\right) \Gamma\left(\frac{v_0}{2}\right)} \\
 &\times \sum_{k_1=0}^{\infty} \sum_{k_2=0}^{\infty} \frac{\left(\frac{a+v_0}{2}\right)_{k_1+k_2}}{\left(\frac{a}{2}\right)_{k_1} \left(\frac{v_0}{2}\right)_{k_2} k_1! k_2!} \left(\frac{\lambda \delta_a}{2(\lambda + u_0)}\right)^{k_1} \left(\frac{\delta_0 u_0}{2(\lambda + u_0)}\right)^{k_2}.
 \end{aligned} \tag{3.25}$$

The result (3.20) follows after applying (B.6) and (B.13).

(b) Integrating (3.15) with respect to  $u_2$ , gives

$$\begin{aligned}
 &f(u_1) \\
 &= \frac{e^{-\left(\frac{\delta_a + \delta_0 + \delta_1 + \delta_2}{2}\right)} \lambda^{\frac{a}{2}} \Gamma\left(\frac{a+v_0+v_1+v_2}{2}\right) u_1^{\frac{v_1}{2}-1} (1 + u_1)^{-\left(\frac{a+v_0+v_1}{2}\right)}}{\Gamma\left(\frac{v_1}{2}\right) \Gamma\left(\frac{v_2}{2}\right) \Gamma\left(\frac{a+v_0}{2}\right)} \\
 &\times \sum_{k_1=0}^{\infty} \sum_{k_2=0}^{\infty} \sum_{k_3=0}^{\infty} \sum_{k_4=0}^{\infty} \sum_{k_5=0}^{\infty} \frac{\left(\frac{a+v_0+v_1+v_2}{2}\right)_{k_1+k_2+k_3+k_4+k_5} \left(\frac{a}{2}\right)_{k_1+k_5}}{\left(\frac{a}{2}\right)_{k_1} \left(\frac{v_1}{2}\right)_{k_3} \left(\frac{v_2}{2}\right)_{k_4} \left(\frac{a+v_0}{2}\right)_{k_1+k_2+k_5} k_1! k_2! k_3! k_4! k_5!} \\
 &\times \left(\frac{\lambda \delta_a}{2(1 + u_1)}\right)^{k_1} \left(\frac{\delta_0}{2(1 + u_1)}\right)^{k_2} \left(\frac{\delta_1 u_1}{2(1 + u_1)}\right)^{k_3} \left(\frac{\delta_2}{2}\right)^{k_4} \left(\frac{1 - \lambda}{1 + u_1}\right)^{k_5} \\
 &\times \int_0^{\frac{v_2}{2} + k_4 - 1} u_2^{\frac{v_2}{2} + k_4 - 1} (1 + u_2)^{-\left(\frac{a+v_0+v_1+v_2}{2} + k_1 + k_2 + k_3 + k_4 + k_5\right)} du_2.
 \end{aligned} \tag{3.26}$$

Evaluation of the above integral using (B.2) and (B.3) gives

$$\begin{aligned}
 &\int_0^{\frac{v_2}{2} + k_4 - 1} u_2^{\frac{v_2}{2} + k_4 - 1} (1 + u_2)^{-\left(\frac{a+v_0+v_1+v_2}{2} + k_1 + k_2 + k_3 + k_4 + k_5\right)} du_2 \\
 &= \frac{\Gamma\left(\frac{v_2}{2} + k_4\right) \Gamma\left(\frac{a+v_0+v_1}{2} + k_1 + k_2 + k_3 + k_5\right)}{\Gamma\left(\frac{a+v_0+v_1+v_2}{2} + k_1 + k_2 + k_3 + k_4 + k_5\right)}.
 \end{aligned} \tag{3.27}$$

The result (3.21) follows from substituting (3.27) in (3.26), then using (B.4) and (B.6):

### 3. NONCENTRAL GENERALISED MULTIVARIATE BETA TYPE II DISTRIBUTIONS

#### 3.3. The noncentral generalised trivariate beta type II distribution

$$\begin{aligned}
& f(u_1) \\
&= \frac{e^{-\left(\frac{\delta_a + \delta_0 + \delta_1 + \delta_2}{2}\right)} \lambda^{\frac{a}{2}} \Gamma\left(\frac{a+v_0+v_1+v_2}{2}\right)}{\Gamma\left(\frac{v_1}{2}\right) \Gamma\left(\frac{v_2}{2}\right) \Gamma\left(\frac{a+v_0}{2}\right)} u_1^{\frac{v_1}{2}-1} (1+u_1)^{-\left(\frac{a+v_0+v_1}{2}\right)} \\
&\quad \times \sum_{k_1=0}^{\infty} \sum_{k_2=0}^{\infty} \sum_{k_3=0}^{\infty} \sum_{k_4=0}^{\infty} \sum_{k_5=0}^{\infty} \frac{\Gamma\left(\frac{a+v_0+v_1+v_2}{2} + k_1 + k_2 + k_3 + k_4 + k_5\right) \left(\frac{a}{2}\right)_{k_1+k_5} \Gamma\left(\frac{v_2}{2}\right)}{\left(\frac{a}{2}\right)_{k_1} \left(\frac{v_1}{2}\right)_{k_3} \left(\frac{a+v_0}{2}\right)_{k_1+k_2+k_5} \Gamma\left(\frac{a+v_0+v_1+v_2}{2}\right) \Gamma\left(\frac{v_2}{2} + k_4\right) k_1! k_2! k_3! k_4! k_5!} \\
&\quad \times \left(\frac{\lambda \delta_a}{2(1+u_1)}\right)^{k_1} \left(\frac{\delta_0}{2(1+u_1)}\right)^{k_2} \left(\frac{\delta_1 u_1}{2(1+u_1)}\right)^{k_3} \left(\frac{\delta_2}{2}\right)^{k_4} \left(\frac{1-\lambda}{1+u_1}\right)^{k_5} \\
&\quad \times \frac{\Gamma\left(\frac{v_2}{2} + k_4\right) \Gamma\left(\frac{a+v_0+v_1}{2} + k_1 + k_2 + k_3 + k_5\right)}{\Gamma\left(\frac{a+v_0+v_1+v_2}{2} + k_1 + k_2 + k_3 + k_4 + k_5\right)} \\
&= \frac{e^{-\left(\frac{\delta_a + \delta_0 + \delta_1 + \delta_2}{2}\right)} \lambda^{\frac{a}{2}} \Gamma\left(\frac{a+v_0+v_1}{2}\right)}{\Gamma\left(\frac{v_1}{2}\right) \Gamma\left(\frac{a+v_0}{2}\right)} u_1^{\frac{v_1}{2}-1} (1+u_1)^{-\left(\frac{a+v_0+v_1}{2}\right)} \sum_{k_4=0}^{\infty} \frac{\left(\frac{\delta_2}{2}\right)^{k_4}}{k_4!} \\
&\quad \times \sum_{k_1=0}^{\infty} \sum_{k_2=0}^{\infty} \sum_{k_3=0}^{\infty} \sum_{k_5=0}^{\infty} \frac{\left(\frac{a+v_0+v_1}{2}\right)_{k_1+k_2+k_3+k_5} \left(\frac{a}{2}\right)_{k_1+k_5}}{\left(\frac{a}{2}\right)_{k_1} \left(\frac{v_1}{2}\right)_{k_3} \left(\frac{a+v_0}{2}\right)_{k_1+k_2+k_5} k_1! k_2! k_3! k_5!} \\
&\quad \times \left(\frac{\lambda \delta_a}{2(1+u_1)}\right)^{k_1} \left(\frac{\delta_0}{2(1+u_1)}\right)^{k_2} \left(\frac{\delta_1 u_1}{2(1+u_1)}\right)^{k_3} \left(\frac{1-\lambda}{1+u_1}\right)^{k_5} \\
&= \frac{e^{-\left(\frac{\delta_a + \delta_0 + \delta_1}{2}\right)} \lambda^{\frac{a}{2}} \Gamma\left(\frac{a+v_0+v_1}{2}\right)}{\Gamma\left(\frac{v_1}{2}\right) \Gamma\left(\frac{a+v_0}{2}\right)} u_1^{\frac{v_1}{2}-1} (1+u_1)^{-\left(\frac{a+v_0+v_1}{2}\right)} \\
&\quad \times \sum_{k_1=0}^{\infty} \sum_{k_2=0}^{\infty} \sum_{k_3=0}^{\infty} \sum_{k_5=0}^{\infty} \frac{\left(\frac{a+v_0+v_1}{2}\right)_{k_1+k_2+k_3+k_5} \left(\frac{a}{2}\right)_{k_1+k_5}}{\left(\frac{a}{2}\right)_{k_1} \left(\frac{v_1}{2}\right)_{k_3} \left(\frac{a+v_0}{2}\right)_{k_1+k_2+k_5} k_1! k_2! k_3! k_5!} \\
&\quad \times \left(\frac{\lambda \delta_a}{2(1+u_1)}\right)^{k_1} \left(\frac{\delta_0}{2(1+u_1)}\right)^{k_2} \left(\frac{\delta_1 u_1}{2(1+u_1)}\right)^{k_3} \left(\frac{1-\lambda}{1+u_1}\right)^{k_5}.
\end{aligned}$$

(c) Proof follows similarly as in (b). ■

**Remark 3.5** (i) Substituting  $\delta_a = \delta_0 = 0$  in (3.20), the pdf simplifies to the univariate distribution derived in Chapter 2 (see (2.24)), namely

$$\begin{aligned}
f(u_0) &= \frac{\lambda^{\frac{a}{2}} \Gamma\left(\frac{a+v_0}{2}\right)}{\Gamma\left(\frac{a}{2}\right) \Gamma\left(\frac{v_0}{2}\right)} u_0^{\frac{v_0}{2}-1} (u_0 + \lambda)^{-\left(\frac{a+v_0}{2}\right)}, \\
& \qquad \qquad \qquad u_0 > 0.
\end{aligned}$$

(ii) Replacing  $\delta_a$  and  $\delta_0$  with  $2\delta_a$  and  $2\delta_0$ , respectively and setting  $\lambda = 1$ , the pdf (3.20) reduces to that of Tang (1938) [44] given in (3.2).

### 3. NONCENTRAL GENERALISED MULTIVARIATE BETA TYPE II DISTRIBUTIONS

#### 3.4. The noncentral generalised multivariate beta type II distribution

## 3.4 The noncentral generalised multivariate beta type II distribution

In the previous section the noncentral generalised trivariate beta type II distribution emanating from a sequential process, was developed where the focus was on  $j = 1, 2$  in (3.8). Now the interest shifts to the corresponding multivariate case for the problem statement described in Section 3.2. In this section the noncentral generalised multivariate beta type II distribution is proposed.

**Theorem 3.4** *Let  $X, W_i$  with  $i = 0, 1, 2, \dots, p$  be independent noncentral chi-squared random variables with degrees of freedom  $a$  and  $v_i$  and noncentrality parameters  $\delta_a$  and  $\delta_i$  with  $i = 0, 1, 2, \dots, p$ , respectively. Let  $U_0 = \frac{\lambda W_0}{X}$ , and  $U_j = \frac{\lambda W_j}{X + \lambda \sum_{k=0}^{j-1} W_k}$  where  $j = 1, 2, \dots, p$ , and  $\lambda > 0$ . The joint pdf of  $(U_0, U_1, \dots, U_p)$  is given by*

$$\begin{aligned}
 & f(u_0, u_1, \dots, u_p) \\
 &= \frac{e^{-\left(\frac{\delta_a + \delta_0 + \delta_1 + \dots + \delta_p}{2}\right)} \Gamma\left(\frac{a}{2} + \sum_{j=0}^p \frac{v_j}{2}\right) \lambda^{\frac{a}{2}}}{\Gamma\left(\frac{a}{2}\right) \Gamma\left(\frac{v_0}{2}\right) \dots \Gamma\left(\frac{v_p}{2}\right)} \left(\prod_{j=0}^p u_j^{\frac{v_j}{2}-1}\right) \left(\prod_{k=0}^{p-1} (1+u_k)^{\sum_{j=k+1}^p \frac{v_j}{2}}\right) \\
 & \times \left(\lambda + u_0 + \sum_{j=1}^p u_j \prod_{k=0}^{j-1} (1+u_k)\right)^{-\left(\frac{a}{2} + \sum_{j=0}^p \frac{v_j}{2}\right)} \tag{3.28} \\
 & \times \Psi_2^{(p+2)} \left[ \frac{a}{2} + \sum_{j=0}^p \frac{v_j}{2}; \frac{a}{2}, \frac{v_0}{2}, \dots, \frac{v_p}{2}; \frac{\lambda \delta_a}{2z}, \frac{\delta_0 u_0}{2z}, \frac{\delta_1 u_1 (1+u_0)}{2z}, \dots, \frac{\delta_p u_p \prod_{k=0}^{j-1} (1+u_k)}{2z} \right], \\
 & \qquad \qquad \qquad u_j > 0, j = 1, 2, \dots, p,
 \end{aligned}$$

where  $z = \lambda + u_0 + \sum_{j=1}^p u_j \prod_{k=0}^{j-1} (1+u_k)$ ,  $\Psi_2^{(p+2)}$  is the confluent hypergeometric function in  $p + 2$  variables (see (B.11)) with the values of the parameters such that  $f(u_0, u_1, \dots, u_p)$  is a valid pdf.

**Proof.** The joint pdf of  $X, W_0, W_1, \dots, W_p$  is

$$\begin{aligned}
 & f(x, w_0, w_1, \dots, w_p) \\
 &= \frac{e^{-\left(\frac{\delta_a + \delta_0 + \delta_1 + \dots + \delta_p}{2}\right)}}{2^{\frac{a+v_0+\dots+v_p}{2}} \Gamma\left(\frac{a}{2}\right) \Gamma\left(\frac{v_0}{2}\right) \dots \Gamma\left(\frac{v_p}{2}\right)} {}_0F_1\left(\frac{a}{2}; \frac{\delta_a x}{4}\right) {}_0F_1\left(\frac{v_0}{2}; \frac{\delta_0 w_0}{4}\right) {}_0F_1\left(\frac{v_1}{2}; \frac{\delta_1 w_1}{4}\right) \\
 & \times {}_0F_1\left(\frac{v_2}{2}; \frac{\delta_2 w_2}{4}\right) \dots {}_0F_1\left(\frac{v_p}{2}; \frac{\delta_p w_p}{4}\right) \\
 & \times x^{\frac{a}{2}-1} w_0^{\frac{v_0}{2}-1} w_1^{\frac{v_1}{2}-1} w_2^{\frac{v_2}{2}-1} \dots w_p^{\frac{v_p}{2}-1} e^{-\frac{1}{2}(x+w_0+w_1+w_2+\dots+w_p)},
 \end{aligned}$$

### 3. NONCENTRAL GENERALISED MULTIVARIATE BETA TYPE II DISTRIBUTIONS

#### 3.4. The noncentral generalised multivariate beta type II distribution

where  ${}_0F_1(a; z)$  is defined in (B.8).

Let  $U = X$ ,  $U_0 = \frac{\lambda W_0}{X}$  and  $U_j = \frac{\lambda W_j}{X + \lambda \sum_{k=0}^{j-1} W_k}$  where  $j = 1, 2, \dots, p$ .

This gives the inverse transformation:  $X = U$ ,  $W_0 = \frac{1}{\lambda} U_0 U$  and

$W_j = \frac{1}{\lambda} U_j \left( U + \lambda \sum_{k=0}^{j-1} W_k \right) = \frac{1}{\lambda} U_j U \prod_{k=0}^{j-1} (1 + U_k)$  where  $j = 1, 2, \dots, p$  with Jacobian (see (2.10))

$$J(x, w_0, \dots, w_p \rightarrow u, u_0, \dots, u_p) = \left( \frac{u}{\lambda} \right)^{p+1} \prod_{k=0}^{p-1} (1 + u_k)^{p-k}.$$

Thus, the joint pdf of  $U, U_0, U_1, \dots, U_p$  is

$$\begin{aligned} f(u, u_0, \dots, u_p) &= \frac{e^{-\left(\frac{\delta_a + \delta_0 + \delta_1 + \dots + \delta_p}{2}\right) \lambda \left(-\sum_{j=0}^p \frac{v_j}{2}\right)}}{2^{\frac{a+v_0+\dots+v_p}{2}} \Gamma\left(\frac{a}{2}\right) \Gamma\left(\frac{v_0}{2}\right) \dots \Gamma\left(\frac{v_p}{2}\right)} {}_0F_1\left(\frac{a}{2}; \frac{\delta_a u}{4}\right) {}_0F_1\left(\frac{v_0}{2}; \frac{\delta_0 u_0 u}{4\lambda}\right) \quad (3.29) \\ &\times \left( \prod_{j=1}^p {}_0F_1\left(\frac{v_j}{2}; \frac{\delta_j u_j u \prod_{k=0}^{j-1} (1+u_k)}{4\lambda}\right) \right) u^{\frac{a}{2} + \sum_{j=0}^p \frac{v_j}{2} - 1} u_0^{\frac{v_0}{2} - 1} \left( \prod_{j=1}^p u_j^{\frac{v_j}{2} - 1} \right) \\ &\times \left( \prod_{k=0}^{p-1} (1 + u_k)^{j=k+1} \right) e^{-\frac{u}{2} \left( 1 + \frac{u_0}{\lambda} + \sum_{j=1}^p \frac{u_j}{\lambda} \prod_{k=0}^{j-1} (1+u_k) \right)}. \end{aligned}$$

Note that (see (2.12))  $\prod_{j=1}^p \left[ \prod_{k=0}^{j-1} (1 + u_k) \right]^{\frac{v_j}{2} - 1} = \prod_{k=0}^{p-1} (1 + u_k)^{\sum_{j=k+1}^p \frac{v_j}{2} - (p-k)}$ .

Expanding the  ${}_0F_1(\cdot)$  expressions in (3.29) in series form (see (B.8)) and integrating with respect to  $u$  using (B.18) gives

$$\begin{aligned} &f(u, u_0, \dots, u_p) \\ &= \frac{e^{-\left(\frac{\delta_a + \delta_0 + \delta_1 + \dots + \delta_p}{2}\right) \lambda \left(-\sum_{j=0}^p \frac{v_j}{2}\right)}}{2^{\frac{a+v_0+\dots+v_p}{2}} \Gamma\left(\frac{a}{2}\right) \Gamma\left(\frac{v_0}{2}\right) \dots \Gamma\left(\frac{v_p}{2}\right)} \int_0^\infty \sum_{k_1=0}^\infty \sum_{k_2=0}^\infty \frac{\left(\frac{\delta_a u}{4}\right)^{k_1}}{\left(\frac{a}{2}\right)_{k_1} k_1!} \frac{\left(\frac{\delta_0 u_0 u}{4\lambda}\right)^{k_2}}{\left(\frac{v_0}{2}\right)_{k_2} k_2!} \\ &\times \left( \prod_{j=1}^p \sum_{k_{j+2}=0}^\infty \frac{\left( \frac{\delta_j u_j u \prod_{k=0}^{j-1} (1+u_k)}{4\lambda} \right)^{k_{j+2}}}{\left(\frac{v_j}{2}\right)_{k_{j+2}} k_{j+2}!} \right) u^{\frac{a}{2} + \sum_{j=0}^p \frac{v_j}{2} - 1} u_0^{\frac{v_0}{2} - 1} \left( \prod_{j=1}^p u_j^{\frac{v_j}{2} - 1} \right) \\ &\times \left( \prod_{k=0}^{p-1} (1 + u_k)^{j=k+1} \right) e^{-\frac{u}{2} \left( 1 + \frac{u_0}{\lambda} + \sum_{j=1}^p \frac{u_j}{\lambda} \prod_{k=0}^{j-1} (1+u_k) \right)} du \end{aligned}$$

### 3. NONCENTRAL GENERALISED MULTIVARIATE BETA TYPE II DISTRIBUTIONS

#### 3.4. The noncentral generalised multivariate beta type II distribution

$$\begin{aligned}
&= \frac{e^{-\left(\frac{\delta_a + \delta_0 + \delta_1 + \dots + \delta_p}{2}\right)} \lambda \left(-\sum_{j=0}^p \frac{v_j}{2}\right)}{2^{\frac{a+v_0+\dots+v_p}{2}} \Gamma\left(\frac{a}{2}\right) \Gamma\left(\frac{v_0}{2}\right) \dots \Gamma\left(\frac{v_p}{2}\right)} u_0^{\frac{v_0}{2}-1} \left(\prod_{j=1}^p u_j^{\frac{v_j}{2}-1}\right) \left(\prod_{k=0}^{p-1} (1+u_k)^{\sum_{j=k+1}^p \frac{v_j}{2}}\right) \\
&\quad \times \sum_{k_1=0}^{\infty} \sum_{k_2=0}^{\infty} \frac{\left(\frac{\delta_a}{4}\right)^{k_1}}{\left(\frac{a}{2}\right)_{k_1} k_1!} \frac{\left(\frac{\delta_0 u_0}{4\lambda}\right)^{k_2}}{\left(\frac{v_0}{2}\right)_{k_2} k_2!} \left(\prod_{j=1}^p \sum_{k_{j+2}=0}^{\infty} \frac{\left(\frac{\delta_j u_j \prod_{k=0}^{j-1} (1+u_k)}{4\lambda}\right)^{k_{j+2}}}{\left(\frac{v_j}{2}\right)_{k_{j+2}} k_{j+2}!}\right) \\
&\quad \times \int_0^{\infty} u^{\frac{a}{2} + \sum_{j=0}^p \frac{v_j}{2} + k_1 + k_2 + \dots + k_{p+2} - 1} e^{-\frac{u}{\lambda} \left(1 + \frac{u_0}{\lambda} + \sum_{j=1}^p \frac{u_j}{\lambda} \prod_{k=0}^{j-1} (1+u_k)\right)} du \\
&= \frac{e^{-\left(\frac{\delta_a + \delta_0 + \delta_1 + \dots + \delta_p}{2}\right)} \lambda \left(-\sum_{j=0}^p \frac{v_j}{2}\right)}{2^{\frac{a+v_0+\dots+v_p}{2}} \Gamma\left(\frac{a}{2}\right) \Gamma\left(\frac{v_0}{2}\right) \dots \Gamma\left(\frac{v_p}{2}\right)} u_0^{\frac{v_0}{2}-1} \left(\prod_{j=1}^p u_j^{\frac{v_j}{2}-1}\right) \left(\prod_{k=0}^{p-1} (1+u_k)^{\sum_{j=k+1}^p \frac{v_j}{2}}\right) \\
&\quad \times \sum_{k_1=0}^{\infty} \sum_{k_2=0}^{\infty} \frac{\left(\frac{\delta_a}{4}\right)^{k_1}}{\left(\frac{a}{2}\right)_{k_1} k_1!} \frac{\left(\frac{\delta_0 u_0}{4\lambda}\right)^{k_2}}{\left(\frac{v_0}{2}\right)_{k_2} k_2!} \left(\prod_{j=1}^p \sum_{k_{j+2}=0}^{\infty} \frac{\left(\frac{\delta_j u_j \prod_{k=0}^{j-1} (1+u_k)}{4\lambda}\right)^{k_{j+2}}}{\left(\frac{v_j}{2}\right)_{k_{j+2}} k_{j+2}!}\right) \\
&\quad \times \left(\frac{1 + \frac{u_0}{\lambda} + \sum_{j=1}^p \frac{u_j}{\lambda} \prod_{k=0}^{j-1} (1+u_k)}{2}\right)^{-\left(\frac{a}{2} + \sum_{j=0}^p \frac{v_j}{2} + k_1 + k_2 + \dots + k_{p+2}\right)} \\
&\quad \times \Gamma\left(\frac{a}{2} + \sum_{j=0}^p \frac{v_j}{2} + k_1 + k_2 + \dots + k_{p+2}\right)
\end{aligned}$$



### 3. NONCENTRAL GENERALISED MULTIVARIATE BETA TYPE II DISTRIBUTIONS

#### 3.4. The noncentral generalised multivariate beta type II distribution

$$\begin{aligned}
&= \frac{e^{-\left(\frac{\delta_a + \delta_0 + \delta_1 + \dots + \delta_p}{2}\right)} \Gamma\left(\frac{a}{2} + \sum_{j=0}^p \frac{v_j}{2}\right) \lambda^{\frac{a}{2}}}{\Gamma\left(\frac{a}{2}\right) \Gamma\left(\frac{v_0}{2}\right) \dots \Gamma\left(\frac{v_p}{2}\right)} \left(\prod_{j=0}^p u_j^{\frac{v_j}{2} - 1}\right) \left(\prod_{k=0}^{p-1} (1 + u_k)^{\sum_{j=k+1}^p \frac{v_j}{2}}\right) \\
&\times \left(\lambda + u_0 + \sum_{j=1}^p u_j \prod_{k=0}^{j-1} (1 + u_k)\right)^{-\left(\frac{a}{2} + \sum_{j=0}^p \frac{v_j}{2}\right)} \\
&\times \sum_{k_1=0}^{\infty} \sum_{k_2=0}^{\infty} \frac{\left(\frac{\lambda \delta_a}{2\left(\lambda + u_0 + \sum_{j=1}^p u_j \prod_{k=0}^{j-1} (1 + u_k)\right)}\right)^{k_1}}{\left(\frac{a}{2}\right)_{k_1} k_1!} \frac{\left(\frac{\delta_0 u_0}{2\left(\lambda + u_0 + \sum_{j=1}^p u_j \prod_{k=0}^{j-1} (1 + u_k)\right)}\right)^{k_2}}{\left(\frac{v_0}{2}\right)_{k_2} k_2!} \\
&\times \left(\prod_{j=1}^p \sum_{k_{j+2}=0}^{\infty} \frac{\left(\frac{\delta_j u_j \prod_{k=0}^{j-1} (1 + u_k)}{2\left(\lambda + u_0 + \sum_{j=1}^p u_j \prod_{k=0}^{j-1} (1 + u_k)\right)}\right)^{k_{j+2}}}{\left(\frac{v_j}{2}\right)_{k_{j+2}} k_{j+2}!}\right) \frac{\Gamma\left(\frac{a}{2} + \sum_{j=0}^p \frac{v_j}{2} + k_1 + k_2 + \dots + k_{p+2}\right)}{\Gamma\left(\frac{a}{2} + \sum_{j=0}^p \frac{v_j}{2}\right)} \\
&= \frac{e^{-\left(\frac{\delta_a + \delta_0 + \delta_1 + \dots + \delta_p}{2}\right)} \Gamma\left(\frac{a}{2} + \sum_{j=0}^p \frac{v_j}{2}\right) \lambda^{\frac{a}{2}}}{\Gamma\left(\frac{a}{2}\right) \Gamma\left(\frac{v_0}{2}\right) \dots \Gamma\left(\frac{v_p}{2}\right)} \left(\prod_{j=0}^p u_j^{\frac{v_j}{2} - 1}\right) \left(\prod_{k=0}^{p-1} (1 + u_k)^{\sum_{j=k+1}^p \frac{v_j}{2}}\right) \\
&\times \left(\lambda + u_0 + \sum_{j=1}^p u_j \prod_{k=0}^{j-1} (1 + u_k)\right)^{-\left(\frac{a}{2} + \sum_{j=0}^p \frac{v_j}{2}\right)} \times \\
&\times \sum_{k_1=0}^{\infty} \sum_{k_2=0}^{\infty} \dots \sum_{k_{p+2}=0}^{\infty} \frac{\left(\frac{a}{2} + \sum_{j=0}^p \frac{v_j}{2}\right)^{k_1 + k_2 + \dots + k_{p+2}}}{\left(\frac{a}{2}\right)_{k_1} \left(\frac{v_0}{2}\right)_{k_2} \dots \left(\frac{v_p}{2}\right)_{k_{p+2}} k_1! k_2! \dots k_{p+2}!} \left(\frac{\lambda \delta_a}{2z}\right)^{k_1} \left(\frac{\delta_0 u_0}{2z}\right)^{k_2} \left(\frac{\delta_1 u_1 (1 + u_0)}{2z}\right)^{k_3} \dots \\
&\times \left(\frac{\delta_p u_p \prod_{k=0}^{j-1} (1 + u_k)}{2z}\right)^{k_{p+2}},
\end{aligned}$$

where  $z = \lambda + u_0 + \sum_{j=1}^p u_j \prod_{k=0}^{j-1} (1 + u_k)$ . Result (3.28) follows from (B.11). ■

**Remark 3.6** If  $\delta_a = \delta_0 = \delta_1 = \dots = \delta_p = 0$ , the distribution with pdf given in (3.28) simplifies to the multivariate distribution derived in Chapter 2 (see (2.8)),

### 3. NONCENTRAL GENERALISED MULTIVARIATE BETA TYPE II DISTRIBUTIONS

#### 3.5. Shape analysis

---

$$\begin{aligned}
 f(u_0, u_1, \dots, u_p) &= \frac{\Gamma\left(\frac{a}{2} + \sum_{j=0}^p \frac{v_j}{2}\right) \lambda^{\frac{a}{2}}}{\Gamma\left(\frac{a}{2}\right) \Gamma\left(\frac{v_0}{2}\right) \dots \Gamma\left(\frac{v_p}{2}\right)} \left(\prod_{j=0}^p u_j^{\frac{v_j}{2}-1}\right) \left(\prod_{k=0}^{p-1} (1+u_k)^{\sum_{j=k+1}^p \frac{v_j}{2}}\right) \\
 &\quad \times \left(\lambda + u_0 + \sum_{j=1}^p u_j \prod_{k=0}^{j-1} (1+u_k)\right)^{-\left(\frac{a}{2} + \sum_{j=0}^p \frac{v_j}{2}\right)}, \\
 &\qquad\qquad\qquad u_j > 0, j = 1, 2, \dots, p.
 \end{aligned}$$

## 3.5 Shape analysis

In this section the shape of the univariate (see (3.20)) and bivariate (see (3.13)) marginal pdfs will be illustrated and the influence of the noncentrality parameters will be investigated. The software package Mathematica was used.

The parameters can be interpreted as follows, based on the process control application:

- $\lambda$  : size of the unknown shift in the variance,
- $a$  : pooled number of observations before the shift in the unknown variance took place,
- $v_0$  : sample size at time period  $\kappa$ , the first sample following the shift in the variance; the shift in the variance took place between samples  $\kappa - 1$  and  $\kappa$ ,
- $\delta_a$  : noncentrality parameter that quantifies the change in the mean before the change in the variance took place,
- $\delta_0$  : noncentrality parameter that quantifies the change in the mean after the change in the variance took place.

Take note that if the mean and variance changes simultaneously, then  $\delta_a = 0$ .

Panels (i) and (ii) of Figure 3.2 illustrate the effect of the noncentrality parameters  $\delta_a$  and  $\delta_0$  on the univariate marginal pdf of  $U_0$  (see (3.20)).

### 3. NONCENTRAL GENERALISED MULTIVARIATE BETA TYPE II DISTRIBUTIONS

#### 3.5. Shape analysis

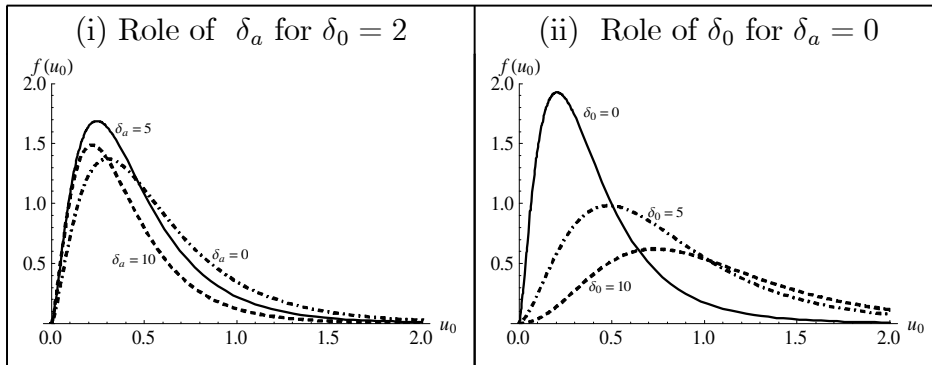

**Figure 3.2** The marginal pdf (3.20) for different values of the parameters  $\delta_a$  and  $\delta_0$  for  $\lambda = 1.5$ ,  $\kappa = 5$ ,  $a = 20$  and  $v_0 = 5$

Panel (i) shows the effect of  $\delta_a$ ; as  $\delta_a$  increases the pdf initially moves towards the vertical axis and then towards the horizontal axis. In panel (ii) the pdf moves towards the horizontal axis for bigger values of  $\delta_0$ . The influence of the parameters  $a$ ,  $v_0 = v$  and  $\lambda$  on the marginal pdf is discussed in detail in Chapter 2, Section 2.6.

Panels (ii) to (v) of Figure 3.3 illustrate the effect of the noncentrality parameters  $\delta_a$ ,  $\delta_0$  and  $\delta_1$  on the bivariate pdf of  $U_0, U_1$  (see (3.13)) for  $\lambda = 1.5$ ,  $\kappa = 5$ ,  $a = 20$ ,  $v_0 = v_1 = 5$ . Panel (i) is the central case, i.e.  $\delta_a = \delta_0 = \delta_1 = 0$  (see (2.39)), included for comparison purposes. For  $\lambda < 1$  the pattern is similar. The effect of  $\lambda$  is addressed in Chapter 2, Section 2.6.

### 3. NONCENTRAL GENERALISED MULTIVARIATE BETA TYPE II DISTRIBUTIONS

#### 3.5. Shape analysis

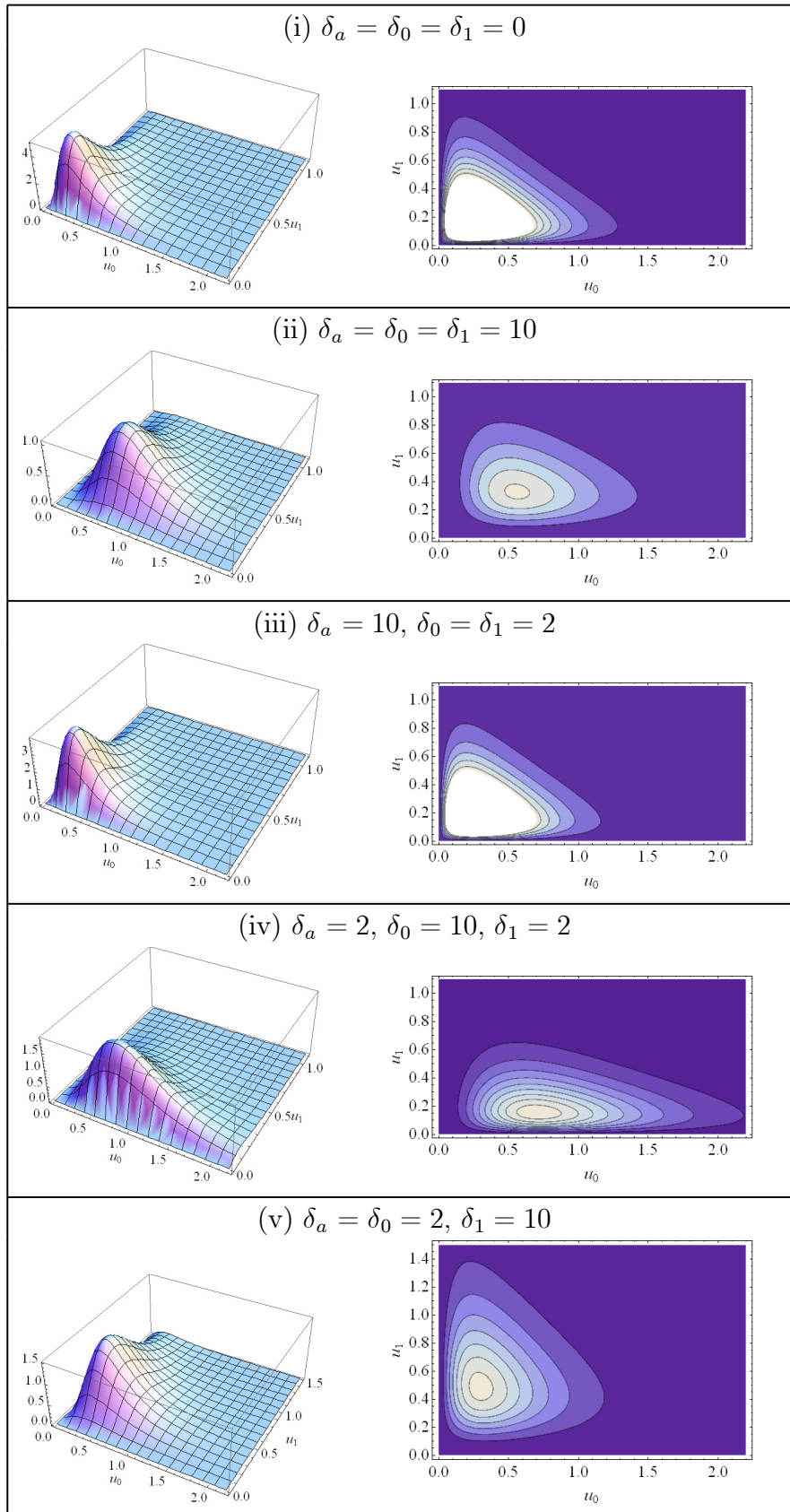

**Figure 3.3** The bivariate pdf (3.13) for different values of the parameters  $\delta_a$  and  $\delta_0$  for  $\lambda = 1.5, \kappa = 5, a = 20$  and  $v_0 = 5$

### 3. NONCENTRAL GENERALISED MULTIVARIATE BETA TYPE II DISTRIBUTIONS

#### 3.6. Conclusion

---

## 3.6 Conclusion

In this chapter, the distributions are proposed for the case when measurements from each sample are independent and identically distributed normal random variables and the unknown variance is monitored when the known mean encountered a sustained shift. Three scenarios were considered based on the timing of the shift in the mean. The proposed model is also extended to the multivariate case i.e. the noncentral generalised multivariate beta type II distribution. The effect of the noncentrality parameters were investigated graphically.

In Chapter 5 the focus for the example will also be on this sequential process where the unknown variance is monitored with a shift in the known mean. The probability to detect a shift in the variance immediately will be calculated using the exact pdf of  $U_0$  (see (3.20)).

## Chapter 4

# Generalised bimatrix variate beta type II distributions

### 4.1 Introduction

In this chapter the generalised bimatrix variate beta type II distribution is proposed. This distribution emanates from monitoring the process covariance structure of  $q$  attributes where samples are independent, having been collected from a multivariate normal distribution with known mean vector and unknown covariance matrix. Two matrix variates that correspond to the two time periods, immediately after the change in the covariance structure took place, will be considered. Section 4.2 gives an outline of the sequential process that introduces new Wishart ratios. The generalised bimatrix variate beta type II distribution is derived in Sections 4.3.1 for the case where the covariance structure changes by a scale factor and in Section 4.3.2 it is derived for the case with a complete change in the covariance structure. In each of these sections the joint and marginal pdfs are given, the moments and product moment of the determinants as well as the pdfs of the determinants and product of the determinants are derived. The latter property is investigated since it plays a role in the calculations discussed in Chapter 5.

### 4.2 Problem statement

In this section the problem of monitoring the process variance, when the mean remains unchanged and measurements are from a normal distribution, will be extended to matrix variates.

Suppose the covariance structure of  $q$  attributes of the items of a single process are monitored simultaneously where the samples are independent having been collected from

## 4. GENERALISED BIMATRIX VARIATE BETA TYPE II DISTRIBUTIONS

### 4.2. Problem statement

a multivariate normal distribution with known mean vector ( $\underline{\mu}_0$ ) and unknown covariance matrix ( $\Sigma : q \times q$ ), denoted as  $MVN(\underline{\mu}_0, \Sigma)$ . At each point in time ( $i$ ) a sample of size  $n_i$  is collected. To this end let  $\mathbf{Y}^{(i)} : n_i \times q$  denote the matrix of observations for time period  $i$ , where  $\underline{Y}_1^{(i)}, \underline{Y}_2^{(i)}, \dots, \underline{Y}_q^{(i)}$  denote the column vectors (i.e. the  $n_i$  observations of each attribute) and  $\underline{Y}_{(1)}^{(i)}, \underline{Y}_{(2)}^{(i)}, \dots, \underline{Y}_{(n_i)}^{(i)}$  denote the row vectors (i.e. observations of each sample) of  $\mathbf{Y}^{(i)}$ , i.e.

$$\mathbf{Y}^{(i)} : n_i \times q = \begin{pmatrix} Y_{11}^{(i)} & Y_{12}^{(i)} & \cdots & Y_{1q}^{(i)} \\ Y_{21}^{(i)} & Y_{22}^{(i)} & \cdots & Y_{2q}^{(i)} \\ \vdots & \vdots & & \vdots \\ Y_{n_i 1}^{(i)} & Y_{n_i 2}^{(i)} & \cdots & Y_{n_i q}^{(i)} \end{pmatrix} = \begin{pmatrix} \underline{Y}_1^{(i)} & \underline{Y}_2^{(i)} & \cdots & \underline{Y}_q^{(i)} \end{pmatrix} = \begin{pmatrix} \underline{Y}_{(1)}^{(i)} \\ \underline{Y}_{(2)}^{(i)} \\ \vdots \\ \underline{Y}_{(n_i)}^{(i)} \end{pmatrix}.$$

Assume that the observations within each sample are independent, therefore the row vectors  $\underline{Y}_{(1)}^{(i)}, \underline{Y}_{(2)}^{(i)}, \dots, \underline{Y}_{(n_i)}^{(i)}$  represent independent observations from a  $MVN(\underline{\mu}_0, \Sigma)$  distribution. The sample covariance matrix at time  $i$  is denoted by

$$\mathbf{S}_i : q \times q = \frac{1}{n_i} \sum_{j=1}^{n_i} \left( \underline{Y}_{(j)}^{(i)} - \underline{\mu}_0 \right)' \left( \underline{Y}_{(j)}^{(i)} - \underline{\mu}_0 \right).$$

The first sample is used to obtain an initial estimate of  $\Sigma$ , i.e. the sample covariance matrix  $\mathbf{S}_1$ . At sample number two,  $\mathbf{S}_2$  is compared to  $\mathbf{S}_1$  to check whether the covariance structure is still the same, if it is still the same a pooled sample covariance matrix is calculated which will be compared to  $\mathbf{S}_3$  at time period three. This sequential updating and testing procedure continues until the process is declared out-of-control. It is known that  $\mathbf{S}_i$  has a Wishart distribution (see Muirhead, 1982 [32], Definition 3.1.3, p.82; Corollary 3.2.2, p.86; (C.59)).

In SPC, once the process encountered a permanent / sustained upward or downward step shift, one is interested in determining the probability of detecting the change in the parameter  $\Sigma$  as soon as possible. Suppose that between samples  $\kappa - 1$  and  $\kappa$  the covariance structure changes as shown in Figure 4.1, i.e.

- (a) from  $\Sigma$  to  $\lambda \Sigma$  where  $\lambda > 0$  and  $\lambda \neq 1$ ;
- (b) from  $\Sigma$  to  $\Sigma_1$ .

## 4. GENERALISED BIMATRIX VARIATE BETA TYPE II DISTRIBUTIONS

### 4.2. Problem statement

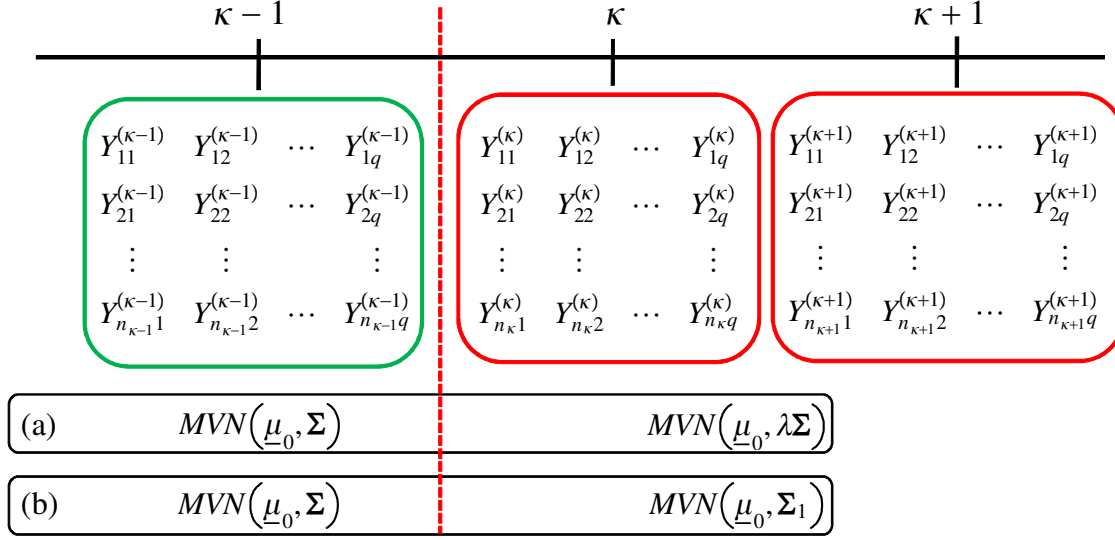

**Figure 4.1** Matrix scenarios

In this study the two matrix random variables,  $\mathbf{U}_0$  and  $\mathbf{U}_1$ , that corresponds to the two successive time periods immediately after the change in the covariance structure occurred (i.e. sample  $\kappa$  and sample  $\kappa + 1$ ) will be studied and is defined analogous to (2.7) by

$$\begin{aligned} \mathbf{U}_0 &= \mathbf{X}^{-\frac{1}{2}} \lambda \mathbf{W}_0 \mathbf{X}^{-\frac{1}{2}}, \\ \mathbf{U}_1 &= (\mathbf{X} + \lambda \mathbf{W}_0)^{-\frac{1}{2}} \lambda \mathbf{W}_1 (\mathbf{X} + \lambda \mathbf{W}_0)^{-\frac{1}{2}}. \end{aligned} \quad (4.1)$$

In this case  $\mathbf{X}$  has a Wishart distribution with parameters  $v_1$  and  $\Sigma$ , denoted  $W_q(v_1, \Sigma)$  (see (C.59)),  $\mathbf{W}_0$  is  $W_q(v_2, \Sigma)$  distributed and  $\mathbf{W}_1$  has a  $W_q(v_3, \Sigma)$  distribution with  $\mathbf{X}$ ,  $\mathbf{W}_0$  and  $\mathbf{W}_1$  independent ( $v_i \geq q, i = 1, 2, 3$ ). Note that  $\mathbf{A}^{\frac{1}{2}}$  is the unique positive definite square root of  $\mathbf{A}$  (see (C.33)). In terms of the SPC application the parameters  $v_1 = \sum_{i=1}^{\kappa-1} n_i$ ,  $v_2 = n_{\kappa}$  and  $v_3 = n_{\kappa+1}$ . The latter expression (4.1) can be rewritten

$$\begin{aligned} \mathbf{U}_0 &= \mathbf{X}^{-\frac{1}{2}} \mathbf{W}_0 \mathbf{X}^{-\frac{1}{2}}, \\ \mathbf{U}_1 &= (\mathbf{X} + \mathbf{W}_0)^{-\frac{1}{2}} \mathbf{W}_1 (\mathbf{X} + \mathbf{W}_0)^{-\frac{1}{2}}, \end{aligned} \quad (4.2)$$

where  $\mathbf{X} \sim W_q(v_1, \Sigma)$ ,  $\mathbf{W}_0 \sim W_q(v_2, \lambda\Sigma)$  and  $\mathbf{W}_1 \sim W_q(v_3, \lambda\Sigma)$  for Scenario (a). Furthermore  $\mathbf{W}_0 \sim W_q(v_2, \Sigma_1)$  and  $\mathbf{W}_1 \sim W_q(v_3, \Sigma_1)$  for scenario (b) with  $\mathbf{X}$ ,  $\mathbf{W}_0$  and  $\mathbf{W}_1$  independent ( $v_i \geq q, i = 1, 2, 3$ ). The symmetric form of the ratios will be considered.

Subsequently, a short overview of existing bimatrix variate beta type II models will be given to position the new model that will be derived.



## 4. GENERALISED BIMATRIX VARIATE BETA TYPE II DISTRIBUTIONS

### 4.2. Problem statement

- Díaz-García and Gutiérrez-Jáimez (2010) [8] extended the bivariate generalised beta type II / or F distribution to the matrix variate case with ratios:

$$\begin{aligned}\mathbf{U}_0 &= \mathbf{X}^{-\frac{1}{2}} \mathbf{W}_0 \mathbf{X}^{-\frac{1}{2}}, \\ \mathbf{U}_1 &= \mathbf{X}^{-\frac{1}{2}} \mathbf{W}_1 \mathbf{X}^{-\frac{1}{2}},\end{aligned}\tag{4.3}$$

where  $\mathbf{X} \sim W_q(v_1, \Sigma)$ ,  $\mathbf{W}_i \sim W_q(v_{i+2}, \Sigma)$   $i = 0, 1$  be independent. The pdf of  $(\mathbf{U}_0, \mathbf{U}_1)$  (see (4.3)) is

$$\frac{\Gamma_q\left(\frac{1}{2}(v_1 + v_2 + v_3)\right)}{\Gamma_q\left(\frac{1}{2}v_1\right) \Gamma_q\left(\frac{1}{2}v_2\right) \Gamma_q\left(\frac{1}{2}v_3\right)} |\mathbf{U}_0|^{\frac{1}{2}v_2 - \frac{1}{2}(q+1)} |\mathbf{U}_1|^{\frac{1}{2}v_3 - \frac{1}{2}(q+1)} |\mathbf{I}_q + \mathbf{U}_0 + \mathbf{U}_1|^{-\frac{1}{2}(v_1 + v_2 + v_3)}$$

where  $\mathbf{U}_i > \mathbf{0}$ ,  $i = 0, 1$  with  $\text{Re}(v_i) > q - 1$ ,  $i = 1, 2, 3$ .

- Bekker et al. (2011) [5] defined the bimatrix variate extended F distribution as follows:

$$\begin{aligned}\mathbf{U}_0 &= \mathbf{X}^{-\frac{1}{2}} \mathbf{W}_0 \mathbf{X}^{-\frac{1}{2}}, \\ \mathbf{U}_1 &= (\mathbf{X} + \mathbf{W}_2)^{-\frac{1}{2}} \mathbf{W}_1 (\mathbf{X} + \mathbf{W}_2)^{-\frac{1}{2}},\end{aligned}\tag{4.4}$$

where  $\mathbf{W}_i \sim W_q(v_{i+2}, \Sigma)$ ,  $i = 0, 1, 2$  and  $\mathbf{X} \sim W_q(v_1, \Sigma)$  are independent. The pdf of  $(\mathbf{U}_0, \mathbf{U}_1)$  (see (4.4)) is

$$\begin{aligned}&\frac{\beta_q\left(\frac{1}{2}(v_1 + v_2), \frac{1}{2}v_4\right)}{\beta_q\left(\frac{1}{2}v_1, \frac{1}{2}v_2, \frac{1}{2}v_3; \frac{1}{2}v_4\right)} |\mathbf{U}_0|^{\frac{1}{2}v_2 - \frac{1}{2}(q+1)} |\mathbf{U}_1|^{\frac{1}{2}v_3 - \frac{1}{2}(q+1)} |\mathbf{I}_q + \mathbf{U}_1|^{-\frac{1}{2}(v_1 + v_2 + v_3 + v_4)} \\ &\times {}_2F_1\left(\frac{1}{2}(v_1 + v_2), \frac{1}{2}(v_1 + v_2 + v_3 + v_4); \frac{1}{2}(v_1 + v_2 + v_4); -\mathbf{U}_0 (\mathbf{I}_q + \mathbf{U}_1)^{-1}\right)\end{aligned}$$

where  $\mathbf{U}_i > \mathbf{0}$ ,  $i = 0, 1$  with  $|\mathbf{U}_0 (\mathbf{I}_q + \mathbf{U}_1)^{-1}| < 1$ ,  $\text{Re}(v_i) > q - 1$ ,  $i = 1, 2, 3, 4$  and  $\beta_q\left(\frac{1}{2}(v_1 + v_2), \frac{1}{2}v_4\right)$  is the multivariate beta function (see (C.36)),  $\beta_q\left(\frac{1}{2}v_1, \frac{1}{2}v_2, \frac{1}{2}v_3; \frac{1}{2}v_4\right)$  is the multivariate Dirichlet function (see (C.37)) and  ${}_2F_1(\cdot)$  is the Gauss hypergeometric function of matrix argument (see (C.52)).

This chapter focuses on the matrix variate random variables (4.2), because the distribution of these matrix random variables is unknown and plays a role when calculating the run-length probabilities. In Chapter 5 some measures are proposed. To develop an exact expression of a run-length of one, one may use the distribution of  $|\mathbf{U}_0|$ ; for  $N = 2$  the joint distribution of  $|\mathbf{U}_0|, |\mathbf{U}_1|$  plays a role, because after a change occurred, there is no

## 4. GENERALISED BIMATRIX VARIATE BETA TYPE II DISTRIBUTIONS

### 4.3. The generalised bimatrix variate beta type II distributions

---

longer independency. Furthermore, as a two-sample statistic for testing the hypothesis at time  $\kappa$  that the two independent samples are from the  $q$ -variate multivariate normal distributions with the same unknown covariance matrix  $\Sigma$ , the statistic  $|\mathbf{U}_0|$  may be of interest as a test statistic. Subsequently  $|\mathbf{U}_1|$  can be used at time  $\kappa + 1$ . Thus  $|\mathbf{U}_0|$  and  $|\mathbf{U}_1|$  may be used as charting statistics for the multivariate process. For scenario (a) (see Figure 4.1),  $|\mathbf{U}_0|$  is in fact a test statistic to check whether  $\lambda = 1$  (i.e. the covariance matrices are the same) versus  $\lambda \neq 1$  (i.e. the covariance matrix change with the scale factor  $\lambda$ ). For  $\lambda = 1$ ,  $|\mathbf{U}_0|$  is the Wilks' statistic type II (see Pham-Gia and Turkkan, 2011 [40]). Take note that it is assumed that the mean vector is known; without any loss of generality it is assumed that the mean vector is the zero vector.

In the next section the generalised bimatrix variate beta type II distribution is derived. Section 4.3.1 considers the case where  $\mathbf{X} \sim W_q(v_1, \Sigma)$ ,  $\mathbf{W}_0 \sim W_q(v_2, \lambda\Sigma)$  and  $\mathbf{W}_1 \sim W_q(v_3, \lambda\Sigma)$  are independent. In Section 4.3.1.1 the pdf of this newly defined bimatrix variate generalised beta type II distribution is derived with the marginal pdfs in Section 4.3.1.2. The product moment  $E[|\mathbf{U}_0|^{h_1}|\mathbf{U}_1|^{h_2}]$  is derived in Section 4.3.1.3 and is used to obtain exact expressions for the pdfs of  $|\mathbf{U}_0|$ ,  $|\mathbf{U}_1|$  and  $|\mathbf{U}_0\mathbf{U}_1|$  in Section 4.3.1.4. The case where it is not only a scale transformation of the covariance matrix but a complete change in the covariance matrix structure (i.e. from  $\Sigma$  to  $\Sigma_1$ ) will be discussed in Section 4.3.2.

This study only considers the situation where the process covariance matrix structure changed. The case where the mean also changes from  $\underline{\mu}_0$  to  $\underline{\mu}_1$  falls outside the scope of this thesis.

## 4.3 The generalised bimatrix variate beta type II distributions

### 4.3.1 The covariance structure change from $\Sigma$ to $\lambda\Sigma$

In this section the generalised bimatrix variate beta type II distribution is derived for the case where the covariance structure  $\Sigma$  changes with a scale factor i.e.  $\lambda\Sigma$ . For the bivariate case ( $q = 2$ ) an example of a contour plot of the multivariate normal distribution is given in Figure 4.2 to illustrate the effect of the change in the covariance matrix. The pdf of  $(\mathbf{U}_0, \mathbf{U}_1)$  (4.2) is derived in Theorem 4.1. Sections 4.3.1.2 to 4.3.1.4 consider some characteristics of this distribution with specific focus on the marginal distributions, followed by an exact expression for the product moment. Finally the pdfs of  $|\mathbf{U}_0|$ ,  $|\mathbf{U}_1|$

## 4. GENERALISED BIMATRIX VARIATE BETA TYPE II DISTRIBUTIONS

### 4.3. The generalised bimatrix variate beta type II distributions

and  $|\mathbf{U}_0\mathbf{U}_1|$  are derived. Note there is no loss of generality in assuming  $\Sigma = \mathbf{I}_q$  in the derivation of the pdfs.

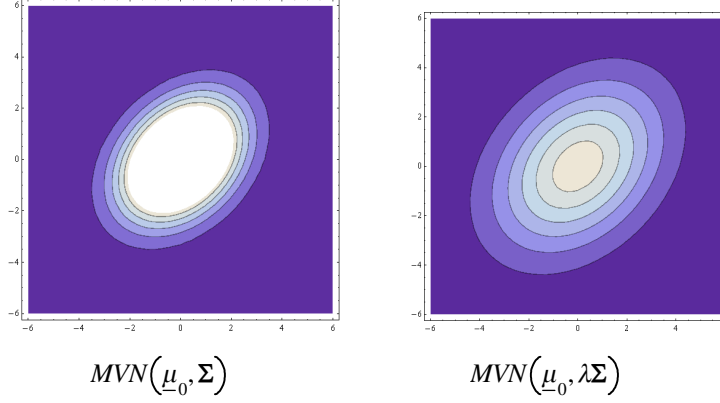

**Figure 4.2** Contour plot to illustrate the change of the covariance matrix by a scale factor

#### 4.3.1.1 The probability density function

The pdf of the generalised bimatrix variate beta type II distribution is derived in Theorem 4.1.

**Theorem 4.1** *Suppose that  $\mathbf{X} \sim W_q(v_1, \Sigma)$  is independent of  $\mathbf{W}_0 \sim W_q(v_2, \lambda \Sigma)$  and  $\mathbf{W}_1 \sim W_q(v_3, \lambda \Sigma)$ . Then the pdf of (4.2) is given by*

$$f(\mathbf{U}_0, \mathbf{U}_1) = \frac{\Gamma_q\left(\frac{1}{2}(v_1 + v_2 + v_3)\right) \lambda^{\frac{1}{2}qv_1}}{\prod_{i=1}^3 \Gamma_q\left(\frac{1}{2}v_i\right)} |\mathbf{U}_0|^{\frac{1}{2}v_2 - \frac{1}{2}(q+1)} |\mathbf{I}_q + \mathbf{U}_0|^{\frac{1}{2}v_3} \quad (4.5)$$

$$\times |\mathbf{U}_1|^{\frac{1}{2}v_3 - \frac{1}{2}(q+1)} \left| \lambda \mathbf{I}_q + \mathbf{U}_0 + (\mathbf{I}_q + \mathbf{U}_0)^{\frac{1}{2}} \mathbf{U}_1 (\mathbf{I}_q + \mathbf{U}_0)^{\frac{1}{2}} \right|^{-\frac{1}{2}(v_1 + v_2 + v_3)},$$

where  $\mathbf{U}_i > \mathbf{0}$ ,  $i = 0, 1$  with  $\text{Re}(v_i) > q - 1$ ,  $i = 1, 2, 3$  and  $\Gamma_q(\cdot)$  is the multivariate gamma function (see (C.34)).

**Proof.** The joint pdf of  $\mathbf{X}, \mathbf{W}_0, \mathbf{W}_1$  is given by (see (C.59))

$$f(\mathbf{X}, \mathbf{W}_0, \mathbf{W}_1) = C |\mathbf{X}|^{\frac{1}{2}(v_1 - q - 1)} |\mathbf{W}_0|^{\frac{1}{2}(v_2 - q - 1)} |\mathbf{W}_1|^{\frac{1}{2}(v_3 - q - 1)} \quad (4.6)$$

$$\times \text{etr}\left(-\frac{1}{2}\mathbf{X}\right) \text{etr}\left(-\frac{1}{2}\lambda^{-1}\mathbf{W}_0\right) \text{etr}\left(-\frac{1}{2}\lambda^{-1}\mathbf{W}_1\right),$$

where

$$C^{-1} = 2^{\frac{1}{2}q(v_1 + v_2 + v_3)} \prod_{i=1}^3 \Gamma_q\left(\frac{1}{2}v_i\right) \lambda^{\frac{1}{2}q(v_2 + v_3)}. \quad (4.7)$$

Making the transformation

$$\mathbf{U} = \mathbf{X}, \quad \mathbf{U}_0 = \mathbf{X}^{-\frac{1}{2}} \mathbf{W}_0 \mathbf{X}^{-\frac{1}{2}}, \quad \mathbf{U}_1 = (\mathbf{X} + \mathbf{W}_0)^{-\frac{1}{2}} \mathbf{W}_1 (\mathbf{X} + \mathbf{W}_0)^{-\frac{1}{2}},$$

#### 4. GENERALISED BIMATRIX VARIATE BETA TYPE II DISTRIBUTIONS

##### 4.3. The generalised bimatrix variate beta type II distributions

---

give

$$\begin{aligned} \mathbf{X} = \mathbf{U}, \quad \mathbf{W}_0 = \mathbf{U}^{\frac{1}{2}} \mathbf{U}_0 \mathbf{U}^{\frac{1}{2}}, \quad \mathbf{W}_1 &= \left( \mathbf{U} + \mathbf{U}^{\frac{1}{2}} \mathbf{U}_0 \mathbf{U}^{\frac{1}{2}} \right)^{\frac{1}{2}} \mathbf{U}_1 \left( \mathbf{U} + \mathbf{U}^{\frac{1}{2}} \mathbf{U}_0 \mathbf{U}^{\frac{1}{2}} \right)^{\frac{1}{2}} \\ &= \left( \mathbf{U}^{\frac{1}{2}} (\mathbf{I}_q + \mathbf{U}_0) \mathbf{U}^{\frac{1}{2}} \right)^{\frac{1}{2}} \mathbf{U}_1 \left( \mathbf{U}^{\frac{1}{2}} (\mathbf{I}_q + \mathbf{U}_0) \mathbf{U}^{\frac{1}{2}} \right)^{\frac{1}{2}}. \end{aligned}$$

From (C.41) and (C.42) the Jacobian of the transformation is

$$\begin{aligned} J(\mathbf{X}, \mathbf{W}_0, \mathbf{W}_1 \rightarrow \mathbf{U}, \mathbf{U}_0, \mathbf{U}_1) &= J(\mathbf{X} \rightarrow \mathbf{U}) J(\mathbf{W}_0 \rightarrow \mathbf{U}_0) J(\mathbf{W}_1 \rightarrow \mathbf{U}_1) \\ &= |\mathbf{U}|^{\frac{1}{2}(q+1)} \left| \mathbf{U}^{\frac{1}{2}} (\mathbf{I}_q + \mathbf{U}_0) \mathbf{U}^{\frac{1}{2}} \right|^{\frac{1}{2}(q+1)} \\ &= |\mathbf{U}|^{q+1} |\mathbf{I}_q + \mathbf{U}_0|^{\frac{1}{2}(q+1)}. \end{aligned} \quad (4.8)$$

Therefore, substituting in (4.6) gives the joint pdf of  $(\mathbf{U}, \mathbf{U}_0, \mathbf{U}_1)$  as

$$\begin{aligned} f(\mathbf{U}, \mathbf{U}_0, \mathbf{U}_1) &= C |\mathbf{U}|^{\frac{1}{2}(v_1 - q - 1)} \left| \mathbf{U}^{\frac{1}{2}} \mathbf{U}_0 \mathbf{U}^{\frac{1}{2}} \right|^{\frac{1}{2}(v_2 - q - 1)} \\ &\quad \times \left| \left( \mathbf{U}^{\frac{1}{2}} (\mathbf{I}_q + \mathbf{U}_0) \mathbf{U}^{\frac{1}{2}} \right)^{\frac{1}{2}} \mathbf{U}_1 \left( \mathbf{U}^{\frac{1}{2}} (\mathbf{I}_q + \mathbf{U}_0) \mathbf{U}^{\frac{1}{2}} \right)^{\frac{1}{2}} \right|^{\frac{1}{2}(v_3 - q - 1)} \\ &\quad \times \text{etr}\left(-\frac{1}{2}\mathbf{U}\right) \text{etr}\left(-\frac{1}{2}\lambda^{-1}\mathbf{U}^{\frac{1}{2}}\mathbf{U}_0\mathbf{U}^{\frac{1}{2}}\right) \\ &\quad \times \text{etr}\left(-\frac{1}{2}\lambda^{-1}\left(\mathbf{U}^{\frac{1}{2}}(\mathbf{I}_q + \mathbf{U}_0)\mathbf{U}^{\frac{1}{2}}\right)^{\frac{1}{2}}\mathbf{U}_1\left(\mathbf{U}^{\frac{1}{2}}(\mathbf{I}_q + \mathbf{U}_0)\mathbf{U}^{\frac{1}{2}}\right)^{\frac{1}{2}}\right) \\ &\quad \times |\mathbf{U}|^{q+1} |\mathbf{I}_q + \mathbf{U}_0|^{\frac{1}{2}(q+1)} \\ &= C |\mathbf{U}|^{\frac{1}{2}(v_1 + v_2 + v_3) - \frac{1}{2}(q+1)} |\mathbf{U}_0|^{\frac{1}{2}v_2 - \frac{1}{2}(q+1)} |\mathbf{I}_q + \mathbf{U}_0|^{\frac{1}{2}v_3} |\mathbf{U}_1|^{\frac{1}{2}v_3 - \frac{1}{2}(q+1)} \\ &\quad \times \text{etr}\left(-\frac{1}{2}\mathbf{U}\right) \text{etr}\left(-\frac{1}{2}\lambda^{-1}\mathbf{U}\mathbf{U}_0\right) \text{etr}\left(-\frac{1}{2}\lambda^{-1}\mathbf{U}^{\frac{1}{2}}(\mathbf{I}_q + \mathbf{U}_0)\mathbf{U}^{\frac{1}{2}}\mathbf{U}_1\right). \end{aligned} \quad (4.9)$$

From (4.9) follows that

$$\begin{aligned} f(\mathbf{U}_0, \mathbf{U}_1) &= C |\mathbf{U}_0|^{\frac{1}{2}v_2 - \frac{1}{2}(q+1)} |\mathbf{I}_q + \mathbf{U}_0|^{\frac{1}{2}v_3} |\mathbf{U}_1|^{\frac{1}{2}v_3 - \frac{1}{2}(q+1)} \\ &\quad \times \int_{\mathbf{U} > \mathbf{0}} |\mathbf{U}|^{\frac{1}{2}(v_1 + v_2 + v_3) - \frac{1}{2}(q+1)} \text{etr}\left(-\frac{1}{2}\mathbf{U}\right) \text{etr}\left(-\frac{1}{2}\lambda^{-1}\mathbf{U}\mathbf{U}_0\right) \\ &\quad \times \text{etr}\left(-\frac{1}{2}\lambda^{-1}\mathbf{U}^{\frac{1}{2}}(\mathbf{I}_q + \mathbf{U}_0)\mathbf{U}^{\frac{1}{2}}\mathbf{U}_1\right) d\mathbf{U} \\ &= C |\mathbf{U}_0|^{\frac{1}{2}v_2 - \frac{1}{2}(q+1)} |\mathbf{I}_q + \mathbf{U}_0|^{\frac{1}{2}v_3} |\mathbf{U}_1|^{\frac{1}{2}v_3 - \frac{1}{2}(q+1)} g_1(\mathbf{U}_1), \end{aligned} \quad (4.10)$$

#### 4. GENERALISED BIMATRIX VARIATE BETA TYPE II DISTRIBUTIONS

##### 4.3. The generalised bimatrix variate beta type II distributions

where

$$g_1(\mathbf{U}_1) = \int_{\mathbf{U} > \mathbf{0}} |\mathbf{U}|^{\frac{1}{2}(v_1+v_2+v_3)-\frac{1}{2}(q+1)} \text{etr}\left(-\frac{1}{2}\mathbf{U}\right) \text{etr}\left(-\frac{1}{2}\lambda^{-1}\mathbf{U}\mathbf{U}_0\right) \\ \times \text{etr}\left(-\frac{1}{2}\lambda^{-1}\mathbf{U}^{\frac{1}{2}}(\mathbf{I}_q + \mathbf{U}_0)\mathbf{U}^{\frac{1}{2}}\mathbf{U}_1\right) d\mathbf{U}.$$

Expanding  $\text{etr}\left(-\frac{1}{2}\lambda^{-1}\mathbf{U}^{\frac{1}{2}}(\mathbf{I}_q + \mathbf{U}_0)\mathbf{U}^{\frac{1}{2}}\mathbf{U}_1\right)$  in terms of the zonal polynomial using (C.50) and applying (C.44) it follows that for any  $\mathbf{H} \in O(q)$ , the orthogonal group, it can be easily seen that  $g_1(\mathbf{U}_1) = g_1(\mathbf{H}\mathbf{U}_1\mathbf{H}')$  (see Muirhead, 1982 [32], p.248). Thus

$$g_1(\mathbf{H}\mathbf{U}_1\mathbf{H}') \\ = \int_{\mathbf{U} > \mathbf{0}} |\mathbf{U}|^{\frac{1}{2}(v_1+v_2+v_3)-\frac{1}{2}(q+1)} \text{etr}\left(-\frac{1}{2}\mathbf{U}\right) \text{etr}\left(-\frac{1}{2}\lambda^{-1}\mathbf{U}\mathbf{U}_0\right) \\ \times \int_{O(q)} \text{etr}\left(-\frac{1}{2}\lambda^{-1}\mathbf{U}^{\frac{1}{2}}(\mathbf{I}_q + \mathbf{U}_0)\mathbf{U}^{\frac{1}{2}}\mathbf{H}\mathbf{U}_1\mathbf{H}'\right) d\mathbf{H}d\mathbf{U} \\ = \int_{\mathbf{U} > \mathbf{0}} |\mathbf{U}|^{\frac{1}{2}(v_1+v_2+v_3)-\frac{1}{2}(q+1)} \text{etr}\left(-\frac{1}{2}\mathbf{U}\right) \text{etr}\left(-\frac{1}{2}\lambda^{-1}\mathbf{U}\mathbf{U}_0\right) \\ \times \sum_t \sum_{\tau} \frac{1}{t!} \int_{O(q)} C_{\tau}\left(-\frac{1}{2}\lambda^{-1}\mathbf{U}^{\frac{1}{2}}(\mathbf{I}_q + \mathbf{U}_0)\mathbf{U}^{\frac{1}{2}}\mathbf{H}\mathbf{U}_1\mathbf{H}'\right) d\mathbf{H}d\mathbf{U} \\ = \int_{\mathbf{U} > \mathbf{0}} |\mathbf{U}|^{\frac{1}{2}(v_1+v_2+v_3)-\frac{1}{2}(q+1)} \text{etr}\left(-\frac{1}{2}\mathbf{U}\right) \text{etr}\left(-\frac{1}{2}\lambda^{-1}\mathbf{U}\mathbf{U}_0\right) \\ \times \sum_t \sum_{\tau} \frac{1}{t!} \int_{O(q)} C_{\tau}\left(-\frac{1}{2}\lambda^{-1}(\mathbf{I}_q + \mathbf{U}_0)^{\frac{1}{2}}\mathbf{U}(\mathbf{I}_q + \mathbf{U}_0)^{\frac{1}{2}}\mathbf{H}\mathbf{U}_1\mathbf{H}'\right) d\mathbf{H}d\mathbf{U},$$

and

$$g_1(\mathbf{U}_1) = \int_{\mathbf{U} > \mathbf{0}} |\mathbf{U}|^{\frac{1}{2}(v_1+v_2+v_3)-\frac{1}{2}(q+1)} \text{etr}\left(-\frac{1}{2}\mathbf{U}\right) \text{etr}\left(-\frac{1}{2}\lambda^{-1}\mathbf{U}\mathbf{U}_0\right) \\ \times \text{etr}\left(-\frac{1}{2}\lambda^{-1}(\mathbf{I}_q + \mathbf{U}_0)^{\frac{1}{2}}\mathbf{U}(\mathbf{I}_q + \mathbf{U}_0)^{\frac{1}{2}}\mathbf{U}_1\right) d\mathbf{U}. \quad (4.11)$$

Substituting (4.11) in (4.10) gives

$$f(\mathbf{U}_0, \mathbf{U}_1) \\ = C |\mathbf{U}_0|^{\frac{1}{2}v_2-\frac{1}{2}(q+1)} |\mathbf{I}_q + \mathbf{U}_0|^{\frac{1}{2}v_3} |\mathbf{U}_1|^{\frac{1}{2}v_3-\frac{1}{2}(q+1)} \\ \times \int_{\mathbf{U} > \mathbf{0}} |\mathbf{U}|^{\frac{1}{2}(v_1+v_2+v_3)-\frac{1}{2}(q+1)} \text{etr}\left(-\frac{1}{2}\mathbf{U}\right) \text{etr}\left(-\frac{1}{2}\lambda^{-1}\mathbf{U}\mathbf{U}_0\right) \\ \times \text{etr}\left(-\frac{1}{2}\lambda^{-1}(\mathbf{I}_q + \mathbf{U}_0)^{\frac{1}{2}}\mathbf{U}(\mathbf{I}_q + \mathbf{U}_0)^{\frac{1}{2}}\mathbf{U}_1\right) d\mathbf{U}$$

## 4. GENERALISED BIMATRIX VARIATE BETA TYPE II DISTRIBUTIONS

### 4.3. The generalised bimatrix variate beta type II distributions

$$= C |\mathbf{U}_0|^{\frac{1}{2}v_2 - \frac{1}{2}(q+1)} |\mathbf{I}_q + \mathbf{U}_0|^{\frac{1}{2}v_3} |\mathbf{U}_1|^{\frac{1}{2}v_3 - \frac{1}{2}(q+1)} \quad (4.12)$$

$$\begin{aligned} & \times \int_{\mathbf{U} > \mathbf{0}} |\mathbf{U}|^{\frac{1}{2}(v_1+v_2+v_3) - \frac{1}{2}(q+1)} \text{etr}\left(-\frac{1}{2}\mathbf{U}\right) \text{etr}\left(-\frac{1}{2}\lambda^{-1}\mathbf{U}\mathbf{U}_0\right) \\ & \times \text{etr}\left(-\frac{1}{2}\lambda^{-1}\mathbf{U}(\mathbf{I}_q + \mathbf{U}_0)^{\frac{1}{2}}\mathbf{U}_1(\mathbf{I}_q + \mathbf{U}_0)^{\frac{1}{2}}\right) d\mathbf{U} \\ & = C |\mathbf{U}_0|^{\frac{1}{2}v_2 - \frac{1}{2}(q+1)} |\mathbf{I}_q + \mathbf{U}_0|^{\frac{1}{2}v_3} |\mathbf{U}_1|^{\frac{1}{2}v_3 - \frac{1}{2}(q+1)} \quad (4.13) \end{aligned}$$

$$\begin{aligned} & \times \int_{\mathbf{U} > \mathbf{0}} |\mathbf{U}|^{\frac{1}{2}(v_1+v_2+v_3) - \frac{1}{2}(q+1)} \\ & \times \text{etr}\left(-\frac{1}{2}\lambda^{-1}\mathbf{U} \left[ \lambda\mathbf{I}_q + \mathbf{U}_0 + (\mathbf{I}_q + \mathbf{U}_0)^{\frac{1}{2}}\mathbf{U}_1(\mathbf{I}_q + \mathbf{U}_0)^{\frac{1}{2}} \right]\right) d\mathbf{U}. \end{aligned}$$

Integrating (4.13) with respect to  $\mathbf{U}$  using (C.54) and substituting  $C$  (4.7) gives the desired result

$$\begin{aligned} f(\mathbf{U}_0, \mathbf{U}_1) &= \frac{1}{2^{\frac{1}{2}q(v_1+v_2+v_3)} \prod_{i=1}^3 \Gamma_q\left(\frac{1}{2}v_i\right) \lambda^{\frac{1}{2}q(v_2+v_3)}} |\mathbf{U}_0|^{\frac{1}{2}v_2 - \frac{1}{2}(q+1)} |\mathbf{I}_q + \mathbf{U}_0|^{\frac{1}{2}v_3} |\mathbf{U}_1|^{\frac{1}{2}v_3 - \frac{1}{2}(q+1)} \\ & \times \Gamma_q\left(\frac{1}{2}(v_1+v_2+v_3)\right) \left| \frac{1}{2}\lambda^{-1} \left[ \lambda\mathbf{I}_q + \mathbf{U}_0 + (\mathbf{I}_q + \mathbf{U}_0)^{\frac{1}{2}}\mathbf{U}_1(\mathbf{I}_q + \mathbf{U}_0)^{\frac{1}{2}} \right] \right|^{-\frac{1}{2}(v_1+v_2+v_3)} \\ &= \frac{\Gamma_q\left(\frac{1}{2}(v_1+v_2+v_3)\right) \lambda^{\frac{1}{2}qv_1}}{\prod_{i=1}^3 \Gamma_q\left(\frac{1}{2}v_i\right)} |\mathbf{U}_0|^{\frac{1}{2}v_2 - \frac{1}{2}(q+1)} |\mathbf{I}_q + \mathbf{U}_0|^{\frac{1}{2}v_3} |\mathbf{U}_1|^{\frac{1}{2}v_3 - \frac{1}{2}(q+1)} \\ & \times \left| \lambda\mathbf{I}_q + \mathbf{U}_0 + (\mathbf{I}_q + \mathbf{U}_0)^{\frac{1}{2}}\mathbf{U}_1(\mathbf{I}_q + \mathbf{U}_0)^{\frac{1}{2}} \right|^{-\frac{1}{2}(v_1+v_2+v_3)}. \end{aligned}$$

■

#### 4.3.1.2 Marginal probability density functions

In this section the marginal pdfs of the generalised bimatrix variate beta type II distribution (4.5) are derived.

**Theorem 4.2** *Suppose that  $\mathbf{X} \sim W_q(v_1, \Sigma)$  is independent of  $\mathbf{W}_0 \sim W_q(v_2, \lambda\Sigma)$  and  $\mathbf{W}_1 \sim W_q(v_3, \lambda\Sigma)$ . If the joint pdf of (4.2) is given by (4.5), then the pdf of*

(a)  $\mathbf{U}_0$  is given by

$$f(\mathbf{U}_0) = \frac{\Gamma_q\left(\frac{1}{2}(v_1+v_2)\right)}{\Gamma_q\left(\frac{1}{2}v_1\right)\Gamma_q\left(\frac{1}{2}v_2\right)} \lambda^{\frac{1}{2}qv_1} |\mathbf{U}_0|^{\frac{1}{2}v_2 - \frac{1}{2}(q+1)} |\lambda\mathbf{I}_q + \mathbf{U}_0|^{-\frac{1}{2}(v_1+v_2)}, \quad (4.14)$$

where  $\mathbf{U}_0 > \mathbf{0}$ , with  $\text{Re}(v_i) > q - 1$ ,  $i = 1, 2$ ,

## 4. GENERALISED BIMATRIX VARIATE BETA TYPE II DISTRIBUTIONS

### 4.3. The generalised bimatrix variate beta type II distributions

---

(b)  $\mathbf{U}_1$  is given by

$$\begin{aligned}
 f(\mathbf{U}_1) &= \frac{\Gamma_q\left(\frac{1}{2}(v_1 + v_2 + v_3)\right)}{\Gamma_q\left(\frac{1}{2}(v_1 + v_2)\right)\Gamma_q\left(\frac{1}{2}v_3\right)} \lambda^{\frac{1}{2}qv_1} |\mathbf{U}_1|^{\frac{1}{2}v_3 - \frac{1}{2}(q+1)} |\lambda\mathbf{I}_q + \mathbf{U}_1|^{-\frac{1}{2}(v_1+v_2+v_3)} \quad (4.15) \\
 &\quad \times {}_2F_1\left(\frac{1}{2}v_2, \frac{1}{2}(v_1+v_2+v_3); \right. \\
 &\quad \left. \frac{1}{2}(v_1+v_2); \mathbf{I}_q - (\mathbf{I}_q + \mathbf{U}_1)^{\frac{1}{2}} (\lambda\mathbf{I}_q + \mathbf{U}_1)^{-1} (\mathbf{I}_q + \mathbf{U}_1)^{\frac{1}{2}}\right),
 \end{aligned}$$

where  $\mathbf{U}_1 > \mathbf{0}$ ,  $\left\| \mathbf{I}_q - (\mathbf{I}_q + \mathbf{U}_1)^{\frac{1}{2}} (\lambda\mathbf{I}_q + \mathbf{U}_1)^{-1} (\mathbf{I}_q + \mathbf{U}_1)^{\frac{1}{2}} \right\| < 1$  with  $\text{Re}(v_i) > q - 1$ ,  $i = 1, 2, 3$  and  ${}_2F_1(\cdot)$  is the Gauss hypergeometric function of matrix argument (see (C.52)).

**Proof.** (a) The marginal pdf of  $\mathbf{U}_0$  is obtained by integrating  $f(\mathbf{U}_0, \mathbf{U}_1)$  (see (4.5)) with respect to  $\mathbf{U}_1$  using (C.53),

$$\begin{aligned}
 f(\mathbf{U}_0) &= \frac{\Gamma_q\left(\frac{1}{2}(v_1 + v_2 + v_3)\right) \lambda^{\frac{1}{2}qv_1}}{\prod_{i=1}^3 \Gamma_q\left(\frac{1}{2}v_i\right)} |\mathbf{U}_0|^{\frac{1}{2}v_2 - \frac{1}{2}(q+1)} |\mathbf{I}_q + \mathbf{U}_0|^{\frac{1}{2}v_3} \\
 &\quad \times \int_{\mathbf{U}_1 > \mathbf{0}} |\mathbf{U}_1|^{\frac{1}{2}v_3 - \frac{1}{2}(q+1)} \left| \lambda\mathbf{I}_q + \mathbf{U}_0 + (\mathbf{I}_q + \mathbf{U}_0)^{\frac{1}{2}} \mathbf{U}_1 (\mathbf{I}_q + \mathbf{U}_0)^{\frac{1}{2}} \right|^{-\frac{1}{2}(v_1+v_2+v_3)} d\mathbf{U}_1 \\
 &= \frac{\Gamma_q\left(\frac{1}{2}(v_1 + v_2 + v_3)\right) \lambda^{\frac{1}{2}qv_1}}{\prod_{i=1}^3 \Gamma_q\left(\frac{1}{2}v_i\right)} |\mathbf{U}_0|^{\frac{1}{2}v_2 - \frac{1}{2}(q+1)} |\mathbf{I}_q + \mathbf{U}_0|^{\frac{1}{2}v_3} \int_{\mathbf{U}_1 > \mathbf{0}} |\mathbf{U}_1|^{\frac{1}{2}v_3 - \frac{1}{2}(q+1)} \\
 &\quad \times \left| (\lambda\mathbf{I}_q + \mathbf{U}_0)^{\frac{1}{2}} \left( \mathbf{I}_q + (\lambda\mathbf{I}_q + \mathbf{U}_0)^{-\frac{1}{2}} (\mathbf{I}_q + \mathbf{U}_0)^{\frac{1}{2}} \mathbf{U}_1 (\mathbf{I}_q + \mathbf{U}_0)^{\frac{1}{2}} (\lambda\mathbf{I}_q + \mathbf{U}_0)^{-\frac{1}{2}} \right) \right. \\
 &\quad \left. (\lambda\mathbf{I}_q + \mathbf{U}_0)^{\frac{1}{2}} \right|^{-\frac{1}{2}(v_1+v_2+v_3)} d\mathbf{U}_1 \\
 &= \frac{\Gamma_q\left(\frac{1}{2}(v_1 + v_2 + v_3)\right) \lambda^{\frac{1}{2}qv_1}}{\prod_{i=1}^3 \Gamma_q\left(\frac{1}{2}v_i\right)} |\mathbf{U}_0|^{\frac{1}{2}v_2 - \frac{1}{2}(q+1)} |\mathbf{I}_q + \mathbf{U}_0|^{\frac{1}{2}v_3} |\lambda\mathbf{I}_q + \mathbf{U}_0|^{-\frac{1}{2}(v_1+v_2+v_3)} \\
 &\quad \times \int_{\mathbf{U}_1 > \mathbf{0}} |\mathbf{U}_1|^{\frac{1}{2}v_3 - \frac{1}{2}(q+1)} \\
 &\quad \times \left| \mathbf{I}_q + (\lambda\mathbf{I}_q + \mathbf{U}_0)^{-\frac{1}{2}} (\mathbf{I}_q + \mathbf{U}_0)^{\frac{1}{2}} \mathbf{U}_1 (\mathbf{I}_q + \mathbf{U}_0)^{\frac{1}{2}} (\lambda\mathbf{I}_q + \mathbf{U}_0)^{-\frac{1}{2}} \right|^{-\frac{1}{2}(v_1+v_2+v_3)} d\mathbf{U}_1 \\
 &= \frac{\Gamma_q\left(\frac{1}{2}(v_1 + v_2 + v_3)\right) \lambda^{\frac{1}{2}qv_1}}{\prod_{i=1}^3 \Gamma_q\left(\frac{1}{2}v_i\right)} |\mathbf{U}_0|^{\frac{1}{2}v_2 - \frac{1}{2}(q+1)} |\mathbf{I}_q + \mathbf{U}_0|^{\frac{1}{2}v_3} |\lambda\mathbf{I}_q + \mathbf{U}_0|^{-\frac{1}{2}(v_1+v_2+v_3)} \\
 &\quad \times \int_{\mathbf{U}_1 > \mathbf{0}} |\mathbf{U}_1|^{\frac{1}{2}v_3 - \frac{1}{2}(q+1)} \left| \mathbf{I}_q + (\mathbf{I}_q + \mathbf{U}_0)^{\frac{1}{2}} (\lambda\mathbf{I}_q + \mathbf{U}_0)^{-1} (\mathbf{I}_q + \mathbf{U}_0)^{\frac{1}{2}} \mathbf{U}_1 \right|^{-\frac{1}{2}(v_1+v_2+v_3)} d\mathbf{U}_1
 \end{aligned}$$

#### 4. GENERALISED BIMATRIX VARIATE BETA TYPE II DISTRIBUTIONS

##### 4.3. The generalised bimatrix variate beta type II distributions

---

$$\begin{aligned}
 &= \frac{\Gamma_q\left(\frac{1}{2}(v_1 + v_2 + v_3)\right) \lambda^{\frac{1}{2}qv_1}}{\prod_{i=1}^3 \Gamma_q\left(\frac{1}{2}v_i\right)} |\mathbf{U}_0|^{\frac{1}{2}v_2 - \frac{1}{2}(q+1)} |\mathbf{I}_q + \mathbf{U}_0|^{\frac{1}{2}v_3} |\lambda\mathbf{I}_q + \mathbf{U}_0|^{-\frac{1}{2}(v_1+v_2+v_3)} \\
 &\quad \times \beta_q\left(\frac{1}{2}v_3, \frac{1}{2}(v_1 + v_2)\right) \left| (\mathbf{I}_q + \mathbf{U}_0)^{\frac{1}{2}} (\lambda\mathbf{I}_q + \mathbf{U}_0)^{-1} (\mathbf{I}_q + \mathbf{U}_0)^{\frac{1}{2}} \right|^{-\frac{1}{2}(v_1+v_2+v_3)} \\
 &\quad \times {}_2F_1\left(\frac{1}{2}(v_1+v_2), \frac{1}{2}(v_1+v_2+v_3); \frac{1}{2}(v_1+v_2+v_3); \mathbf{I}_q - (\mathbf{I}_q + \mathbf{U}_0)^{-\frac{1}{2}} (\lambda\mathbf{I}_q + \mathbf{U}_0) (\mathbf{I}_q + \mathbf{U}_0)^{-\frac{1}{2}}\right) \\
 &= \frac{\Gamma_q\left(\frac{1}{2}(v_1 + v_2 + v_3)\right) \lambda^{\frac{1}{2}qv_1}}{\prod_{i=1}^3 \Gamma_q\left(\frac{1}{2}v_i\right)} |\mathbf{U}_0|^{\frac{1}{2}v_2 - \frac{1}{2}(q+1)} |\mathbf{I}_q + \mathbf{U}_0|^{\frac{1}{2}v_3} |\lambda\mathbf{I}_q + \mathbf{U}_0|^{-\frac{1}{2}(v_1+v_2+v_3)} \\
 &\quad \times \beta_q\left(\frac{1}{2}v_3, \frac{1}{2}(v_1 + v_2)\right) \left| (\mathbf{I}_q + \mathbf{U}_0)^{\frac{1}{2}} (\lambda\mathbf{I}_q + \mathbf{U}_0)^{-1} (\mathbf{I}_q + \mathbf{U}_0)^{\frac{1}{2}} \right|^{-\frac{1}{2}(v_1+v_2+v_3)} \\
 &\quad \times {}_1F_0\left(\frac{1}{2}(v_1 + v_2); \mathbf{I}_q - (\mathbf{I}_q + \mathbf{U}_0)^{-\frac{1}{2}} (\lambda\mathbf{I}_q + \mathbf{U}_0) (\mathbf{I}_q + \mathbf{U}_0)^{-\frac{1}{2}}\right) \\
 &= \frac{\Gamma_q\left(\frac{1}{2}(v_1 + v_2 + v_3)\right) \lambda^{\frac{1}{2}qv_1}}{\prod_{i=1}^3 \Gamma_q\left(\frac{1}{2}v_i\right)} |\mathbf{U}_0|^{\frac{1}{2}v_2 - \frac{1}{2}(q+1)} |\mathbf{I}_q + \mathbf{U}_0|^{-\frac{1}{2}(v_1+v_2)} \beta_q\left(\frac{1}{2}v_3, \frac{1}{2}(v_1 + v_2)\right) \\
 &\quad \times {}_1F_0\left(\frac{1}{2}(v_1 + v_2); \mathbf{I}_q - (\mathbf{I}_q + \mathbf{U}_0)^{-\frac{1}{2}} (\lambda\mathbf{I}_q + \mathbf{U}_0) (\mathbf{I}_q + \mathbf{U}_0)^{-\frac{1}{2}}\right) \\
 &= \frac{\Gamma_q\left(\frac{1}{2}(v_1 + v_2 + v_3)\right) \lambda^{\frac{1}{2}qv_1}}{\prod_{i=1}^3 \Gamma_q\left(\frac{1}{2}v_i\right)} |\mathbf{U}_0|^{\frac{1}{2}v_2 - \frac{1}{2}(q+1)} |\mathbf{I}_q + \mathbf{U}_0|^{-\frac{1}{2}(v_1+v_2)} \frac{\Gamma_q\left(\frac{1}{2}(v_1 + v_2)\right) \Gamma_q\left(\frac{1}{2}v_3\right)}{\Gamma_q\left(\frac{1}{2}(v_1 + v_2 + v_3)\right)} \\
 &\quad \times \left| \mathbf{I}_q - \left(\mathbf{I}_q - (\mathbf{I}_q + \mathbf{U}_0)^{-\frac{1}{2}} (\lambda\mathbf{I}_q + \mathbf{U}_0) (\mathbf{I}_q + \mathbf{U}_0)^{-\frac{1}{2}}\right) \right|^{-\frac{1}{2}(v_1+v_2)} \\
 &= \frac{\Gamma_q\left(\frac{1}{2}(v_1 + v_2)\right) \lambda^{\frac{1}{2}qv_1}}{\Gamma_q\left(\frac{1}{2}v_1\right) \Gamma_q\left(\frac{1}{2}v_2\right)} |\mathbf{U}_0|^{\frac{1}{2}v_2 - \frac{1}{2}(q+1)} |\lambda\mathbf{I}_q + \mathbf{U}_0|^{-\frac{1}{2}(v_1+v_2)},
 \end{aligned}$$

where  $\beta_q(\cdot)$  is the multivariate beta function (see (C.36)) and  ${}_1F_0(\cdot)$  is the hypergeometric function of matrix argument (see (C.51)). The latter two steps follows from writing the multivariate beta function in terms of the multivariate gamma function (C.36), applying (C.51) and simplifying the result.

(b) From (4.12) follows that

$$\begin{aligned}
 &f(\mathbf{U}_1) \\
 &= \int_{\mathbf{U}_0 > \mathbf{0}} \int_{\mathbf{U} > \mathbf{0}} C |\mathbf{U}_0|^{\frac{1}{2}v_2 - \frac{1}{2}(q+1)} |\mathbf{I}_q + \mathbf{U}_0|^{\frac{1}{2}v_3} |\mathbf{U}_1|^{\frac{1}{2}v_3 - \frac{1}{2}(q+1)} |\mathbf{U}|^{\frac{1}{2}(v_1+v_2+v_3) - \frac{1}{2}(q+1)} \\
 &\quad \times \text{etr}\left(-\frac{1}{2}\mathbf{U}\right) \text{etr}\left(-\frac{1}{2}\lambda^{-1}\mathbf{U}\mathbf{U}_0\right) \text{etr}\left(-\frac{1}{2}\lambda^{-1}(\mathbf{I}_q + \mathbf{U}_0)^{\frac{1}{2}} \mathbf{U} (\mathbf{I}_q + \mathbf{U}_0)^{\frac{1}{2}} \mathbf{U}_1\right) d\mathbf{U}d\mathbf{U}_0
 \end{aligned}$$



4. GENERALISED BIMATRIX VARIATE BETA TYPE II DISTRIBUTIONS  
 4.3. The generalised bimatrix variate beta type II distributions

---

$$\begin{aligned}
 &= C |\mathbf{U}_1|^{\frac{1}{2}v_3 - \frac{1}{2}(q+1)} \int_{\mathbf{U} > \mathbf{0}} |\mathbf{U}|^{\frac{1}{2}(v_1+v_2+v_3) - \frac{1}{2}(q+1)} \text{etr}\left(-\frac{1}{2}\mathbf{U}\right) \int_{\mathbf{U}_0 > \mathbf{0}} |\mathbf{U}_0|^{\frac{1}{2}v_2 - \frac{1}{2}(q+1)} |\mathbf{I}_q + \mathbf{U}_0|^{\frac{1}{2}v_3} \\
 &\quad \times \text{etr}\left(-\frac{1}{2}\lambda^{-1}\mathbf{U}\mathbf{U}_0\right) \text{etr}\left(-\frac{1}{2}\lambda^{-1}(\mathbf{I}_q + \mathbf{U}_0)^{\frac{1}{2}}\mathbf{U}(\mathbf{I}_q + \mathbf{U}_0)^{\frac{1}{2}}\mathbf{U}_1\right) d\mathbf{U}_0 d\mathbf{U} \\
 &= C |\mathbf{U}_1|^{\frac{1}{2}v_3 - \frac{1}{2}(q+1)} \int_{\mathbf{U} > \mathbf{0}} |\mathbf{U}|^{\frac{1}{2}(v_1+v_2+v_3) - \frac{1}{2}(q+1)} \text{etr}\left(-\frac{1}{2}\mathbf{U}\right) g_2(\mathbf{U}_1) d\mathbf{U}, \tag{4.16}
 \end{aligned}$$

where

$$\begin{aligned}
 g_2(\mathbf{U}_1) &= \int_{\mathbf{U}_0 > \mathbf{0}} |\mathbf{U}_0|^{\frac{1}{2}v_2 - \frac{1}{2}(q+1)} |\mathbf{I}_q + \mathbf{U}_0|^{\frac{1}{2}v_3} \text{etr}\left(-\frac{1}{2}\lambda^{-1}\mathbf{U}\mathbf{U}_0\right) \\
 &\quad \times \text{etr}\left(-\frac{1}{2}\lambda^{-1}(\mathbf{I}_q + \mathbf{U}_0)^{\frac{1}{2}}\mathbf{U}(\mathbf{I}_q + \mathbf{U}_0)^{\frac{1}{2}}\mathbf{U}_1\right) d\mathbf{U}_0.
 \end{aligned}$$

Expanding  $\text{etr}\left(-\frac{1}{2}\lambda^{-1}(\mathbf{I}_q + \mathbf{U}_0)^{\frac{1}{2}}\mathbf{U}(\mathbf{I}_q + \mathbf{U}_0)^{\frac{1}{2}}\mathbf{U}_1\right)$  in terms of the zonal polynomial using (C.50) and applying (C.44) it follows that for any  $\mathbf{H} \in O(q)$ ,  $g_2(\mathbf{U}_1) = g_2(\mathbf{H}\mathbf{U}_1\mathbf{H}')$  with

$$\begin{aligned}
 &g_2(\mathbf{H}\mathbf{U}_1\mathbf{H}') \\
 &= \int_{\mathbf{U}_0 > \mathbf{0}} |\mathbf{U}_0|^{\frac{1}{2}v_2 - \frac{1}{2}(q+1)} |\mathbf{I}_q + \mathbf{U}_0|^{\frac{1}{2}v_3} \text{etr}\left(-\frac{1}{2}\lambda^{-1}\mathbf{U}\mathbf{U}_0\right) \\
 &\quad \times \int_{O(q)} \text{etr}\left(-\frac{1}{2}\lambda^{-1}(\mathbf{I}_q + \mathbf{U}_0)^{\frac{1}{2}}\mathbf{U}(\mathbf{I}_q + \mathbf{U}_0)^{\frac{1}{2}}\mathbf{H}\mathbf{U}_1\mathbf{H}'\right) d\mathbf{H} d\mathbf{U}_0 \\
 &= \int_{\mathbf{U}_0 > \mathbf{0}} |\mathbf{U}_0|^{\frac{1}{2}v_2 - \frac{1}{2}(q+1)} |\mathbf{I}_q + \mathbf{U}_0|^{\frac{1}{2}v_3} \text{etr}\left(-\frac{1}{2}\lambda^{-1}\mathbf{U}\mathbf{U}_0\right) \\
 &\quad \times \sum_t \sum_\tau \frac{1}{t!} \int_{O(q)} C_\tau \left(-\frac{1}{2}\lambda^{-1}(\mathbf{I}_q + \mathbf{U}_0)^{\frac{1}{2}}\mathbf{U}(\mathbf{I}_q + \mathbf{U}_0)^{\frac{1}{2}}\mathbf{H}\mathbf{U}_1\mathbf{H}'\right) d\mathbf{H} d\mathbf{U}_0 \\
 &= \int_{\mathbf{U}_0 > \mathbf{0}} |\mathbf{U}_0|^{\frac{1}{2}v_2 - \frac{1}{2}(q+1)} |\mathbf{I}_q + \mathbf{U}_0|^{\frac{1}{2}v_3} \text{etr}\left(-\frac{1}{2}\lambda^{-1}\mathbf{U}\mathbf{U}_0\right) \\
 &\quad \times \sum_t \sum_\tau \frac{1}{t!} \int_{O(q)} C_\tau \left(-\frac{1}{2}\lambda^{-1}\mathbf{U}^{\frac{1}{2}}(\mathbf{I}_q + \mathbf{U}_0)\mathbf{U}^{\frac{1}{2}}\mathbf{H}\mathbf{U}_1\mathbf{H}'\right) d\mathbf{H} d\mathbf{U}_0,
 \end{aligned}$$

and

$$\begin{aligned}
 g_2(\mathbf{U}_1) &= \int_{\mathbf{U}_0 > \mathbf{0}} |\mathbf{U}_0|^{\frac{1}{2}v_2 - \frac{1}{2}(q+1)} |\mathbf{I}_q + \mathbf{U}_0|^{\frac{1}{2}v_3} \text{etr}\left(-\frac{1}{2}\lambda^{-1}\mathbf{U}\mathbf{U}_0\right) \\
 &\quad \times \text{etr}\left(-\frac{1}{2}\lambda^{-1}\mathbf{U}^{\frac{1}{2}}(\mathbf{I}_q + \mathbf{U}_0)\mathbf{U}^{\frac{1}{2}}\mathbf{U}_1\right) d\mathbf{U}_0. \tag{4.17}
 \end{aligned}$$

#### 4. GENERALISED BIMATRIX VARIATE BETA TYPE II DISTRIBUTIONS

##### 4.3. The generalised bimatrix variate beta type II distributions

---

Substituting (4.17) in (4.16) gives

$$\begin{aligned}
 f(\mathbf{U}_1) &= C |\mathbf{U}_1|^{\frac{1}{2}v_3 - \frac{1}{2}(q+1)} \int_{\mathbf{U} > \mathbf{0}} |\mathbf{U}|^{\frac{1}{2}(v_1+v_2+v_3) - \frac{1}{2}(q+1)} \text{etr}\left(-\frac{1}{2}\mathbf{U}\right) \int_{\mathbf{U}_0 > \mathbf{0}} |\mathbf{U}_0|^{\frac{1}{2}v_2 - \frac{1}{2}(q+1)} |\mathbf{I}_q + \mathbf{U}_0|^{\frac{1}{2}v_3} \\
 &\quad \times \text{etr}\left(-\frac{1}{2}\lambda^{-1}\mathbf{U}\mathbf{U}_0\right) \text{etr}\left(-\frac{1}{2}\lambda^{-1}\mathbf{U}^{\frac{1}{2}}(\mathbf{I}_q + \mathbf{U}_0)\mathbf{U}^{\frac{1}{2}}\mathbf{U}_1\right) d\mathbf{U}_0 d\mathbf{U} \\
 &= C |\mathbf{U}_1|^{\frac{1}{2}v_3 - \frac{1}{2}(q+1)} \int_{\mathbf{U} > \mathbf{0}} |\mathbf{U}|^{\frac{1}{2}(v_1+v_2+v_3) - \frac{1}{2}(q+1)} \text{etr}\left(-\frac{1}{2}\mathbf{U}\right) \int_{\mathbf{U}_0 > \mathbf{0}} |\mathbf{U}_0|^{\frac{1}{2}v_2 - \frac{1}{2}(q+1)} |\mathbf{I}_q + \mathbf{U}_0|^{\frac{1}{2}v_3} \\
 &\quad \times \text{etr}\left(-\frac{1}{2}\lambda^{-1}\mathbf{U}\mathbf{U}_0\right) \text{etr}\left(-\frac{1}{2}\lambda^{-1}\mathbf{U}\mathbf{U}_1\right) \text{etr}\left(-\frac{1}{2}\lambda^{-1}\mathbf{U}^{\frac{1}{2}}\mathbf{U}_0\mathbf{U}^{\frac{1}{2}}\mathbf{U}_1\right) d\mathbf{U}_0 d\mathbf{U} \\
 &= C |\mathbf{U}_1|^{\frac{1}{2}v_3 - \frac{1}{2}(q+1)} \int_{\mathbf{U} > \mathbf{0}} |\mathbf{U}|^{\frac{1}{2}(v_1+v_2+v_3) - \frac{1}{2}(q+1)} \text{etr}\left(-\frac{1}{2}\lambda^{-1}\mathbf{U}\mathbf{U}_1\right) \text{etr}\left(-\frac{1}{2}\mathbf{U}\right) \\
 &\quad \times \int_{\mathbf{U}_0 > \mathbf{0}} |\mathbf{U}_0|^{\frac{1}{2}v_2 - \frac{1}{2}(q+1)} |\mathbf{I}_q + \mathbf{U}_0|^{\frac{1}{2}v_3} \text{etr}\left(-\frac{1}{2}\lambda^{-1}\mathbf{U}_0\left(\mathbf{U} + \mathbf{U}^{\frac{1}{2}}\mathbf{U}_1\mathbf{U}^{\frac{1}{2}}\right)\right) d\mathbf{U}_0 d\mathbf{U} \\
 &= C |\mathbf{U}_1|^{\frac{1}{2}v_3 - \frac{1}{2}(q+1)} \int_{\mathbf{U}_0 > \mathbf{0}} |\mathbf{U}_0|^{\frac{1}{2}v_2 - \frac{1}{2}(q+1)} |\mathbf{I}_q + \mathbf{U}_0|^{\frac{1}{2}v_3} \int_{\mathbf{U} > \mathbf{0}} |\mathbf{U}|^{\frac{1}{2}(v_1+v_2+v_3) - \frac{1}{2}(q+1)} \\
 &\quad \times \text{etr}\left(-\frac{1}{2}\lambda^{-1}\mathbf{U}\mathbf{U}_1\right) \text{etr}\left(-\frac{1}{2}\mathbf{U}\right) \text{etr}\left(-\frac{1}{2}\lambda^{-1}\mathbf{U}_0\mathbf{U}^{\frac{1}{2}}(\mathbf{I}_q + \mathbf{U}_1)\mathbf{U}^{\frac{1}{2}}\right) d\mathbf{U} d\mathbf{U}_0 \\
 &= C |\mathbf{U}_1|^{\frac{1}{2}v_3 - \frac{1}{2}(q+1)} \int_{\mathbf{U}_0 > \mathbf{0}} |\mathbf{U}_0|^{\frac{1}{2}v_2 - \frac{1}{2}(q+1)} |\mathbf{I}_q + \mathbf{U}_0|^{\frac{1}{2}v_3} g_3(\mathbf{U}_0) d\mathbf{U}_0, \tag{4.18}
 \end{aligned}$$

where

$$\begin{aligned}
 g_3(\mathbf{U}_0) &= \int_{\mathbf{U} > \mathbf{0}} |\mathbf{U}|^{\frac{1}{2}(v_1+v_2+v_3) - \frac{1}{2}(q+1)} \text{etr}\left(-\frac{1}{2}\lambda^{-1}\mathbf{U}\mathbf{U}_1\right) \text{etr}\left(-\frac{1}{2}\mathbf{U}\right) \\
 &\quad \times \text{etr}\left(-\frac{1}{2}\lambda^{-1}\mathbf{U}_0\mathbf{U}^{\frac{1}{2}}(\mathbf{I}_q + \mathbf{U}_1)\mathbf{U}^{\frac{1}{2}}\right) d\mathbf{U}.
 \end{aligned}$$

Expanding  $\text{etr}\left(-\frac{1}{2}\lambda^{-1}\mathbf{U}_0\mathbf{U}^{\frac{1}{2}}(\mathbf{I}_q + \mathbf{U}_1)\mathbf{U}^{\frac{1}{2}}\right)$  in terms of the zonal polynomial using (C.50) and applying (C.44) it follows that for any  $\mathbf{H} \in O(q)$ ,  $g_3(\mathbf{U}_0) = g_3(\mathbf{H}\mathbf{U}_0\mathbf{H}')$  with

$$\begin{aligned}
 g_3(\mathbf{H}\mathbf{U}_0\mathbf{H}') &= \int_{\mathbf{U} > \mathbf{0}} |\mathbf{U}|^{\frac{1}{2}(v_1+v_2+v_3) - \frac{1}{2}(q+1)} \text{etr}\left(-\frac{1}{2}\lambda^{-1}\mathbf{U}\mathbf{U}_1\right) \text{etr}\left(-\frac{1}{2}\mathbf{U}\right) \\
 &\quad \times \int_{O(q)} \text{etr}\left(-\frac{1}{2}\lambda^{-1}\mathbf{H}\mathbf{U}_0\mathbf{H}'\mathbf{U}^{\frac{1}{2}}(\mathbf{I}_q + \mathbf{U}_1)\mathbf{U}^{\frac{1}{2}}\right) d\mathbf{H} d\mathbf{U} \\
 &= \int_{\mathbf{U} > \mathbf{0}} |\mathbf{U}|^{\frac{1}{2}(v_1+v_2+v_3) - \frac{1}{2}(q+1)} \text{etr}\left(-\frac{1}{2}\lambda^{-1}\mathbf{U}\mathbf{U}_1\right) \text{etr}\left(-\frac{1}{2}\mathbf{U}\right) \\
 &\quad \times \sum_t \sum_\tau \frac{1}{t!} \int_{O(q)} C_\tau \left(-\frac{1}{2}\lambda^{-1}\mathbf{H}\mathbf{U}_0\mathbf{H}'\mathbf{U}^{\frac{1}{2}}(\mathbf{I}_q + \mathbf{U}_1)\mathbf{U}^{\frac{1}{2}}\right) d\mathbf{H} d\mathbf{U}
 \end{aligned}$$

#### 4. GENERALISED BIMATRIX VARIATE BETA TYPE II DISTRIBUTIONS

##### 4.3. The generalised bimatrix variate beta type II distributions

$$\begin{aligned}
 &= \int_{\mathbf{U}>\mathbf{0}} |\mathbf{U}|^{\frac{1}{2}(v_1+v_2+v_3)-\frac{1}{2}(q+1)} \text{etr}\left(-\frac{1}{2}\lambda^{-1}\mathbf{U}\mathbf{U}_1\right) \text{etr}\left(-\frac{1}{2}\mathbf{U}\right) \\
 &\quad \times \sum_t \sum_\tau \frac{1}{t!} \int_{O(q)} C_\tau \left(-\frac{1}{2}\lambda^{-1}\mathbf{H}\mathbf{U}_0\mathbf{H}'(\mathbf{I}_q+\mathbf{U}_1)^{\frac{1}{2}}\mathbf{U}(\mathbf{I}_q+\mathbf{U}_1)^{\frac{1}{2}}\right) d\mathbf{H}d\mathbf{U},
 \end{aligned}$$

and

$$\begin{aligned}
 g_3(\mathbf{U}_0) &= \int_{\mathbf{U}>\mathbf{0}} |\mathbf{U}|^{\frac{1}{2}(v_1+v_2+v_3)-\frac{1}{2}(q+1)} \text{etr}\left(-\frac{1}{2}\lambda^{-1}\mathbf{U}\mathbf{U}_1\right) \text{etr}\left(-\frac{1}{2}\mathbf{U}\right) \\
 &\quad \times \text{etr}\left(-\frac{1}{2}\lambda^{-1}\mathbf{U}_0(\mathbf{I}_q+\mathbf{U}_1)^{\frac{1}{2}}\mathbf{U}(\mathbf{I}_q+\mathbf{U}_1)^{\frac{1}{2}}\right) d\mathbf{U}.
 \end{aligned} \tag{4.19}$$

Substituting (4.19) in (4.18) and applying (C.56) gives

$$\begin{aligned}
 &f(\mathbf{U}_1) \\
 &= C |\mathbf{U}_1|^{\frac{1}{2}v_3-\frac{1}{2}(q+1)} \int_{\mathbf{U}_0>\mathbf{0}} |\mathbf{U}_0|^{\frac{1}{2}v_2-\frac{1}{2}(q+1)} |\mathbf{I}_q+\mathbf{U}_0|^{\frac{1}{2}v_3} \int_{\mathbf{U}>\mathbf{0}} |\mathbf{U}|^{\frac{1}{2}(v_1+v_2+v_3)-\frac{1}{2}(q+1)} \\
 &\quad \times \text{etr}\left(-\frac{1}{2}\lambda^{-1}\mathbf{U}\mathbf{U}_1\right) \text{etr}\left(-\frac{1}{2}\mathbf{U}\right) \text{etr}\left(-\frac{1}{2}\lambda^{-1}\mathbf{U}_0(\mathbf{I}_q+\mathbf{U}_1)^{\frac{1}{2}}\mathbf{U}(\mathbf{I}_q+\mathbf{U}_1)^{\frac{1}{2}}\right) d\mathbf{U}d\mathbf{U}_0 \\
 &= C |\mathbf{U}_1|^{\frac{1}{2}v_3-\frac{1}{2}(q+1)} \int_{\mathbf{U}>\mathbf{0}} |\mathbf{U}|^{\frac{1}{2}(v_1+v_2+v_3)-\frac{1}{2}(q+1)} \text{etr}\left(-\frac{1}{2}\lambda^{-1}\mathbf{U}\mathbf{U}_1\right) \text{etr}\left(-\frac{1}{2}\mathbf{U}\right) \\
 &\quad \times \int_{\mathbf{U}_0>\mathbf{0}} |\mathbf{U}_0|^{\frac{1}{2}v_2-\frac{1}{2}(q+1)} |\mathbf{I}_q+\mathbf{U}_0|^{\frac{1}{2}v_3} \text{etr}\left(-\frac{1}{2}\lambda^{-1}\mathbf{U}_0(\mathbf{I}_q+\mathbf{U}_1)^{\frac{1}{2}}\mathbf{U}(\mathbf{I}_q+\mathbf{U}_1)^{\frac{1}{2}}\right) d\mathbf{U}_0d\mathbf{U} \\
 &= C |\mathbf{U}_1|^{\frac{1}{2}v_3-\frac{1}{2}(q+1)} \int_{\mathbf{U}>\mathbf{0}} |\mathbf{U}|^{\frac{1}{2}(v_1+v_2+v_3)-\frac{1}{2}(q+1)} \text{etr}\left(-\frac{1}{2}\lambda^{-1}\mathbf{U}\mathbf{U}_1\right) \text{etr}\left(-\frac{1}{2}\mathbf{U}\right) \\
 &\quad \times \Gamma_q\left(\frac{1}{2}v_2\right) \Psi\left(\frac{1}{2}v_2, \frac{1}{2}(v_2+v_3)+\frac{1}{2}(q+1), \frac{1}{2}\lambda^{-1}(\mathbf{I}_q+\mathbf{U}_1)^{\frac{1}{2}}\mathbf{U}(\mathbf{I}_q+\mathbf{U}_1)^{\frac{1}{2}}\right) d\mathbf{U} \\
 &= C |\mathbf{U}_1|^{\frac{1}{2}v_3-\frac{1}{2}(q+1)} \Gamma_q\left(\frac{1}{2}v_2\right) \int_{\mathbf{U}>\mathbf{0}} |\mathbf{U}|^{\frac{1}{2}(v_1+v_2+v_3)-\frac{1}{2}(q+1)} \text{etr}\left(-\frac{1}{2}\lambda^{-1}(\mathbf{U}_1+\lambda\mathbf{I}_q)\mathbf{U}\right) \\
 &\quad \times \Psi\left(\frac{1}{2}v_2, \frac{1}{2}(v_2+v_3)+\frac{1}{2}(q+1), \frac{1}{2}\lambda^{-1}(\mathbf{I}_q+\mathbf{U}_1)^{\frac{1}{2}}\mathbf{U}(\mathbf{I}_q+\mathbf{U}_1)^{\frac{1}{2}}\right) d\mathbf{U}.
 \end{aligned} \tag{4.20}$$

Integrating (4.20) with respect to  $\mathbf{U}$  using (C.58) and substituting  $C$  (4.7) gives

$$\begin{aligned}
 &f(\mathbf{U}_1) \\
 &= \frac{\Gamma_q\left(\frac{1}{2}(v_1+v_2+v_3)\right) \Gamma_q\left(\frac{1}{2}v_1\right) \Gamma_q\left(\frac{1}{2}v_2\right)}{2^{\frac{1}{2}q(v_1+v_2+v_3)} \prod_{i=1}^3 \Gamma_q\left(\frac{1}{2}v_i\right) \lambda^{\frac{1}{2}q(v_2+v_3)} \Gamma_q\left(\frac{1}{2}(v_1+v_2)\right)} |\mathbf{U}_1|^{\frac{1}{2}v_3-\frac{1}{2}(q+1)} \\
 &\quad \times \left|\frac{1}{2}\lambda^{-1}(\mathbf{I}_q+\mathbf{U}_1)\right|^{-\frac{1}{2}(v_1+v_2+v_3)} \\
 &\quad \times {}_2F_1\left(\frac{1}{2}(v_1+v_2+v_3), \frac{1}{2}v_1; \frac{1}{2}(v_1+v_2); \mathbf{I}_q - (\mathbf{I}_q+\mathbf{U}_1)^{-\frac{1}{2}}(\lambda\mathbf{I}_q+\mathbf{U}_1)(\mathbf{I}_q+\mathbf{U}_1)^{-\frac{1}{2}}\right)
 \end{aligned}$$

## 4. GENERALISED BIMATRIX VARIATE BETA TYPE II DISTRIBUTIONS

### 4.3. The generalised bimatrix variate beta type II distributions

---

$$\begin{aligned}
 &= \frac{\Gamma_q\left(\frac{1}{2}(v_1 + v_2 + v_3)\right) \lambda^{\frac{1}{2}qv_1}}{\Gamma_q\left(\frac{1}{2}v_3\right) \Gamma_q\left(\frac{1}{2}(v_1 + v_2)\right)} |\mathbf{U}_1|^{\frac{1}{2}v_3 - \frac{1}{2}(q+1)} |\mathbf{I}_q + \mathbf{U}_1|^{-\frac{1}{2}(v_1 + v_2 + v_3)} \\
 &\quad \times {}_2F_1\left(\frac{v_1}{2}, \frac{v_1 + v_2 + v_3}{2}; \frac{v_1 + v_2}{2}; \mathbf{I}_q - (\mathbf{I}_q + \mathbf{U}_1)^{-\frac{1}{2}} (\lambda \mathbf{I}_q + \mathbf{U}_1) (\mathbf{I}_q + \mathbf{U}_1)^{-\frac{1}{2}}\right).
 \end{aligned} \tag{4.21}$$

Rewriting the hypergeometric function of matrix argument,  ${}_2F_1(\cdot)$ , using (C.55) gives

$$\begin{aligned}
 &f(\mathbf{U}_1) \\
 &= \frac{\Gamma_q\left(\frac{1}{2}(v_1 + v_2 + v_3)\right) \lambda^{\frac{1}{2}qv_1}}{\Gamma_q\left(\frac{1}{2}v_3\right) \Gamma_q\left(\frac{1}{2}(v_1 + v_2)\right)} |\mathbf{U}_1|^{\frac{1}{2}v_3 - \frac{1}{2}(q+1)} |\mathbf{I}_q + \mathbf{U}_1|^{-\frac{1}{2}(v_1 + v_2 + v_3)} \\
 &\quad \left| (\mathbf{I}_q + \mathbf{U}_1)^{-\frac{1}{2}} (\lambda \mathbf{I}_q + \mathbf{U}_1) (\mathbf{I}_q + \mathbf{U}_1)^{-\frac{1}{2}} \right|^{-\frac{1}{2}(v_1 + v_2 + v_3)} \\
 &\quad \times {}_2F_1\left(\frac{1}{2}v_2, \frac{1}{2}(v_1 + v_2 + v_3); \frac{1}{2}(v_1 + v_2); \mathbf{I}_q - (\mathbf{I}_q + \mathbf{U}_1)^{\frac{1}{2}} (\lambda \mathbf{I}_q + \mathbf{U}_1)^{-1} (\mathbf{I}_q + \mathbf{U}_1)^{\frac{1}{2}}\right) \\
 &= \frac{\Gamma_q\left(\frac{1}{2}(v_1 + v_2 + v_3)\right) \lambda^{\frac{1}{2}qv_1}}{\Gamma_q\left(\frac{1}{2}v_3\right) \Gamma_q\left(\frac{1}{2}(v_1 + v_2)\right)} |\mathbf{U}_1|^{\frac{1}{2}v_3 - \frac{1}{2}(q+1)} |\lambda \mathbf{I}_q + \mathbf{U}_1|^{-\frac{1}{2}(v_1 + v_2 + v_3)} \\
 &\quad \times {}_2F_1\left(\frac{1}{2}v_2, \frac{1}{2}(v_1 + v_2 + v_3); \frac{1}{2}(v_1 + v_2); \mathbf{I}_q - (\mathbf{I}_q + \mathbf{U}_1)^{\frac{1}{2}} (\lambda \mathbf{I}_q + \mathbf{U}_1)^{-1} (\mathbf{I}_q + \mathbf{U}_1)^{\frac{1}{2}}\right).
 \end{aligned}$$

■

**Remark 4.1** Substituting  $\lambda = 1$  (i.e. there is no change in the covariance structure and therefore the process remains in-control) in (4.14) gives the well-known matrix variate beta type II distribution (see (C.61)) with parameters  $(\frac{1}{2}v_1, \frac{1}{2}v_2)$  with pdf

$$\frac{\Gamma_q\left(\frac{1}{2}(v_1 + v_2)\right)}{\Gamma_q\left(\frac{1}{2}v_1\right) \Gamma_q\left(\frac{1}{2}v_2\right)} |\mathbf{U}_0|^{\frac{1}{2}v_2 - \frac{1}{2}(q+1)} |\mathbf{I}_q + \mathbf{U}_0|^{-\frac{1}{2}(v_1 + v_2)},$$

$\mathbf{U}_0 > \mathbf{0}$ .

#### 4.3.1.3 Product moment of the determinants

The  $(h_1, h_2)^{th}$  product moment,  $E\left(|\mathbf{U}_0|^{h_1} |\mathbf{U}_1|^{h_2}\right)$ , where  $(\mathbf{U}_0, \mathbf{U}_1)$  is distributed as (4.5) is derived in Theorem 4.3 with the  $h^{th}$  moments of  $|\mathbf{U}_0|$  and  $|\mathbf{U}_1|$  given in Lemma 4.3.1. The moments are used to determine the distribution of  $|\mathbf{U}_0|$ ,  $|\mathbf{U}_1|$  and  $|\mathbf{U}_0\mathbf{U}_1|$  in Section 4.3.1.4.

## 4. GENERALISED BIMATRIX VARIATE BETA TYPE II DISTRIBUTIONS

## 4.3. The generalised bimatrix variate beta type II distributions

**Theorem 4.3** Suppose that  $\mathbf{X} \sim W_q(v_1, \Sigma)$  is independent of  $\mathbf{W}_0 \sim W_q(v_2, \lambda\Sigma)$  and  $\mathbf{W}_1 \sim W_q(v_3, \lambda\Sigma)$ . If the joint pdf of (4.2) is given by (4.5), then

$$\begin{aligned}
 & E\left(|\mathbf{U}_0|^{h_1} |\mathbf{U}_1|^{h_2}\right) \\
 &= \frac{\Gamma_q\left(\frac{1}{2}(v_1 + v_2) - h_2\right) \Gamma_q\left(\frac{1}{2}v_3 + h_2\right) \Gamma_q\left(\frac{1}{2}v_1 - h_1\right) \Gamma_q\left(\frac{1}{2}v_2 + h_1\right) \lambda^{\frac{1}{2}qv_1}}{\prod_{i=1}^3 \Gamma_q\left(\frac{1}{2}v_i\right) \Gamma_q\left(\frac{1}{2}(v_1 + v_2)\right)} \quad (4.22) \\
 &\quad \times {}_2F_1\left(\frac{1}{2}v_1 - h_1, \frac{1}{2}(v_1 + v_2) - h_2; \frac{1}{2}(v_1 + v_2); (1 - \lambda)\mathbf{I}_q\right),
 \end{aligned}$$

where  $\|(1 - \lambda)\mathbf{I}_q\| < 1$ ,  $\operatorname{Re}\left(\frac{1}{2}(v_1 + v_2) - h_2\right) > \frac{1}{2}(q - 1)$ ,  $\operatorname{Re}\left(\frac{1}{2}v_3 + h_2\right) > \frac{1}{2}(q - 1)$ ,  $\operatorname{Re}\left(\frac{1}{2}v_1 - h_1\right) > \frac{1}{2}(q - 1)$ ,  $\operatorname{Re}\left(\frac{1}{2}v_2 + h_1\right) > \frac{1}{2}(q - 1)$ .

**Proof.** From (4.5),

$$\begin{aligned}
 & E\left(|\mathbf{U}_0|^{h_1} |\mathbf{U}_1|^{h_2}\right) \\
 &= \int_{\mathbf{U}_0 > \mathbf{0}} \int_{\mathbf{U}_1 > \mathbf{0}} \frac{\Gamma_q\left(\frac{1}{2}(v_1 + v_2 + v_3)\right) \lambda^{\frac{1}{2}qv_1}}{\prod_{i=1}^3 \Gamma_q\left(\frac{1}{2}v_i\right)} |\mathbf{U}_0|^{\frac{1}{2}v_2 + h_1 - \frac{1}{2}(q+1)} |\mathbf{I}_q + \mathbf{U}_0|^{\frac{1}{2}v_3} |\mathbf{U}_1|^{\frac{1}{2}v_3 + h_2 - \frac{1}{2}(q+1)} \\
 &\quad \times \left| \lambda \mathbf{I}_q + \mathbf{U}_0 + (\mathbf{I}_q + \mathbf{U}_0)^{\frac{1}{2}} \mathbf{U}_1 (\mathbf{I}_q + \mathbf{U}_0)^{\frac{1}{2}} \right|^{-\frac{1}{2}(v_1 + v_2 + v_3)} d\mathbf{U}_1 d\mathbf{U}_0 \\
 &= \frac{\Gamma_q\left(\frac{1}{2}(v_1 + v_2 + v_3)\right) \lambda^{\frac{1}{2}qv_1}}{\prod_{i=1}^3 \Gamma_q\left(\frac{1}{2}v_i\right)} \int_{\mathbf{U}_0 > \mathbf{0}} |\mathbf{U}_0|^{\frac{1}{2}v_2 + h_1 - \frac{1}{2}(q+1)} |\mathbf{I}_q + \mathbf{U}_0|^{\frac{1}{2}v_3} \int_{\mathbf{U}_1 > \mathbf{0}} |\mathbf{U}_1|^{\frac{1}{2}v_3 + h_2 - \frac{1}{2}(q+1)} \\
 &\quad \times \left| (\lambda \mathbf{I}_q + \mathbf{U}_0)^{\frac{1}{2}} \left( \mathbf{I}_q + (\lambda \mathbf{I}_q + \mathbf{U}_0)^{-\frac{1}{2}} (\mathbf{I}_q + \mathbf{U}_0)^{\frac{1}{2}} \mathbf{U}_1 (\mathbf{I}_q + \mathbf{U}_0)^{\frac{1}{2}} (\lambda \mathbf{I}_q + \mathbf{U}_0)^{-\frac{1}{2}} \right) \right. \\
 &\quad \left. (\lambda \mathbf{I}_q + \mathbf{U}_0)^{\frac{1}{2}} \right|^{-\frac{1}{2}(v_1 + v_2 + v_3)} d\mathbf{U}_1 d\mathbf{U}_0 \\
 &= \frac{\Gamma_q\left(\frac{1}{2}(v_1 + v_2 + v_3)\right) \lambda^{\frac{1}{2}qv_1}}{\prod_{i=1}^3 \Gamma_q\left(\frac{1}{2}v_i\right)} \int_{\mathbf{U}_0 > \mathbf{0}} |\mathbf{U}_0|^{\frac{1}{2}v_2 + h_1 - \frac{1}{2}(q+1)} |\mathbf{I}_q + \mathbf{U}_0|^{\frac{1}{2}v_3} |\lambda \mathbf{I}_q + \mathbf{U}_0|^{-\frac{1}{2}(v_1 + v_2 + v_3)} \\
 &\quad \times \int_{\mathbf{U}_1 > \mathbf{0}} |\mathbf{U}_1|^{\frac{1}{2}v_3 + h_2 - \frac{1}{2}(q+1)} \\
 &\quad \times \left| \mathbf{I}_q + (\lambda \mathbf{I}_q + \mathbf{U}_0)^{-\frac{1}{2}} (\mathbf{I}_q + \mathbf{U}_0)^{\frac{1}{2}} \mathbf{U}_1 (\mathbf{I}_q + \mathbf{U}_0)^{\frac{1}{2}} (\lambda \mathbf{I}_q + \mathbf{U}_0)^{-\frac{1}{2}} \right|^{-\frac{1}{2}(v_1 + v_2 + v_3)} d\mathbf{U}_1 d\mathbf{U}_0 \\
 &= \frac{\Gamma_q\left(\frac{1}{2}(v_1 + v_2 + v_3)\right) \lambda^{\frac{1}{2}qv_1}}{\prod_{i=1}^3 \Gamma_q\left(\frac{1}{2}v_i\right)} \int_{\mathbf{U}_0 > \mathbf{0}} |\mathbf{U}_0|^{\frac{1}{2}v_2 + h_1 - \frac{1}{2}(q+1)} |\mathbf{I}_q + \mathbf{U}_0|^{\frac{1}{2}v_3} |\lambda \mathbf{I}_q + \mathbf{U}_0|^{-\frac{1}{2}(v_1 + v_2 + v_3)} \quad (4.23) \\
 &\quad \times \int_{\mathbf{U}_1 > \mathbf{0}} |\mathbf{U}_1|^{\frac{1}{2}v_3 + h_2 - \frac{1}{2}(q+1)} \\
 &\quad \times \left| \mathbf{I}_q + (\mathbf{I}_q + \mathbf{U}_0)^{\frac{1}{2}} (\lambda \mathbf{I}_q + \mathbf{U}_0)^{-1} (\mathbf{I}_q + \mathbf{U}_0)^{\frac{1}{2}} \mathbf{U}_1 \right|^{-\frac{1}{2}(v_1 + v_2 + v_3)} d\mathbf{U}_1 d\mathbf{U}_0.
 \end{aligned}$$

4. GENERALISED BIMATRIX VARIATE BETA TYPE II DISTRIBUTIONS  
 4.3. The generalised bimatrix variate beta type II distributions

---

Integrating (4.23) with respect to  $\mathbf{U}_1$  using (C.53) gives

$$\begin{aligned}
 & E \left( |\mathbf{U}_0|^{h_1} |\mathbf{U}_1|^{h_2} \right) \\
 &= \frac{\Gamma_q \left( \frac{1}{2} (v_1 + v_2 + v_3) \right) \lambda^{\frac{1}{2} q v_1}}{\prod_{i=1}^3 \Gamma_q \left( \frac{1}{2} v_i \right)} \int_{\mathbf{U}_0 > \mathbf{0}} |\mathbf{U}_0|^{\frac{1}{2} v_2 + h_1 - \frac{1}{2} (q+1)} |\mathbf{I}_q + \mathbf{U}_0|^{\frac{1}{2} v_3} |\lambda \mathbf{I}_q + \mathbf{U}_0|^{-\frac{1}{2} (v_1 + v_2 + v_3)} \\
 &\quad \times \beta_q \left( \frac{1}{2} v_3 + h_2, \frac{1}{2} (v_1 + v_2) - h_2 \right) \left| (\mathbf{I}_q + \mathbf{U}_0)^{\frac{1}{2}} (\lambda \mathbf{I}_q + \mathbf{U}_0)^{-1} (\mathbf{I}_q + \mathbf{U}_0)^{\frac{1}{2}} \right|^{-\frac{1}{2} (v_1 + v_2 + v_3)} \\
 &\quad \times {}_1F_0 \left( \frac{1}{2} (v_1 + v_2) - h_2; \mathbf{I}_q - (\mathbf{I}_q + \mathbf{U}_0)^{-\frac{1}{2}} (\lambda \mathbf{I}_q + \mathbf{U}_0) (\mathbf{I}_q + \mathbf{U}_0)^{-\frac{1}{2}} \right) d\mathbf{U}_0 \\
 &= \frac{\Gamma_q \left( \frac{1}{2} (v_1 + v_2 + v_3) \right) \lambda^{\frac{1}{2} q v_1}}{\prod_{i=1}^3 \Gamma_q \left( \frac{1}{2} v_i \right)} \tag{4.24} \\
 &\quad \times \int_{\mathbf{U}_0 > \mathbf{0}} |\mathbf{U}_0|^{\frac{1}{2} v_2 + h_1 - \frac{1}{2} (q+1)} |\mathbf{I}_q + \mathbf{U}_0|^{\frac{1}{2} v_3} |\lambda \mathbf{I}_q + \mathbf{U}_0|^{-\frac{1}{2} (v_1 + v_2 + v_3)} \\
 &\quad \times \beta_q \left( \frac{1}{2} v_3 + h_2, \frac{1}{2} (v_1 + v_2) - h_2 \right) |\mathbf{I}_q + \mathbf{U}_0|^{-\frac{1}{2} (v_1 + v_2 + v_3)} |\lambda \mathbf{I}_q + \mathbf{U}_0|^{\frac{1}{2} (v_1 + v_2 + v_3)} \\
 &\quad \times {}_1F_0 \left( \frac{1}{2} (v_1 + v_2) - h_2; \mathbf{I}_q - (\mathbf{I}_q + \mathbf{U}_0)^{-\frac{1}{2}} (\lambda \mathbf{I}_q + \mathbf{U}_0) (\mathbf{I}_q + \mathbf{U}_0)^{-\frac{1}{2}} \right) d\mathbf{U}_0.
 \end{aligned}$$

The hypergeometric function of matrix argument,  ${}_1F_0(\cdot)$ , in (4.24) can be simplified by using (C.51), then

$$\begin{aligned}
 & {}_1F_0 \left( \frac{1}{2} (v_1 + v_2) - h_2; \mathbf{I}_q - (\mathbf{I}_q + \mathbf{U}_0)^{-\frac{1}{2}} (\lambda \mathbf{I}_q + \mathbf{U}_0) (\mathbf{I}_q + \mathbf{U}_0)^{-\frac{1}{2}} \right) \\
 &= \left| (\mathbf{I}_q + \mathbf{U}_0)^{-\frac{1}{2}} (\lambda \mathbf{I}_q + \mathbf{U}_0) (\mathbf{I}_q + \mathbf{U}_0)^{-\frac{1}{2}} \right|^{-\frac{1}{2} (v_1 + v_2) + h_2} \\
 &= |\mathbf{I}_q + \mathbf{U}_0|^{\frac{1}{2} (v_1 + v_2) - h_2} |\lambda \mathbf{I}_q + \mathbf{U}_0|^{-\frac{1}{2} (v_1 + v_2) + h_2}. \tag{4.25}
 \end{aligned}$$

Substituting (4.25) in (4.24) gives

$$\begin{aligned}
 & E \left( |\mathbf{U}_0|^{h_1} |\mathbf{U}_1|^{h_2} \right) \\
 &= \frac{\Gamma_q \left( \frac{1}{2} (v_1 + v_2 + v_3) \right) \lambda^{\frac{1}{2} q v_1}}{\prod_{i=1}^3 \Gamma_q \left( \frac{1}{2} v_i \right)} \beta_q \left( \frac{1}{2} v_3 + h_2, \frac{1}{2} (v_1 + v_2) - h_2 \right) \\
 &\quad \times \int_{\mathbf{U}_0 > \mathbf{0}} |\mathbf{U}_0|^{\frac{1}{2} v_2 + h_1 - \frac{1}{2} (q+1)} |\mathbf{I}_q + \mathbf{U}_0|^{-h_2} |\lambda \mathbf{I}_q + \mathbf{U}_0|^{-\frac{1}{2} (v_1 + v_2) + h_2} d\mathbf{U}_0 \\
 &= \frac{\Gamma_q \left( \frac{1}{2} (v_1 + v_2 + v_3) \right) \lambda^{\frac{1}{2} q v_1}}{\prod_{i=1}^3 \Gamma_q \left( \frac{1}{2} v_i \right)} \beta_q \left( \frac{1}{2} v_3 + h_2, \frac{1}{2} (v_1 + v_2) - h_2 \right) \\
 &\quad \times \int_{\mathbf{U}_0 > \mathbf{0}} |\mathbf{U}_0|^{\frac{1}{2} v_2 + h_1 - \frac{1}{2} (q+1)} |\mathbf{I}_q + \mathbf{U}_0|^{-h_2} |\lambda (\mathbf{I}_q + \lambda^{-1} \mathbf{U}_0)|^{-\frac{1}{2} (v_1 + v_2) + h_2} d\mathbf{U}_0
 \end{aligned}$$

#### 4. GENERALISED BIMATRIX VARIATE BETA TYPE II DISTRIBUTIONS

##### 4.3. The generalised bimatrix variate beta type II distributions

$$\begin{aligned}
 &= \frac{\Gamma_q\left(\frac{1}{2}(v_1 + v_2 + v_3)\right) \lambda^{-\frac{1}{2}qv_2 + qh_2}}{\prod_{i=1}^3 \Gamma_q\left(\frac{1}{2}v_i\right)} \beta_q\left(\frac{1}{2}v_3 + h_2, \frac{1}{2}(v_1 + v_2) - h_2\right) \\
 &\times \int_{\mathbf{U}_0 > \mathbf{0}} |\mathbf{U}_0|^{\frac{1}{2}v_2 + h_1 - \frac{1}{2}(q+1)} |\mathbf{I}_q + \mathbf{U}_0|^{-h_2} |\mathbf{I}_q + \lambda^{-1}\mathbf{U}_0|^{-\frac{1}{2}(v_1 + v_2) + h_2} d\mathbf{U}_0.
 \end{aligned} \tag{4.26}$$

Integrating (4.26) using (C.53) and subsequently replacing the multivariate beta function using (C.36), the  $(h_1, h_2)^{th}$  product moment is

$$\begin{aligned}
 &E\left(|\mathbf{U}_0|^{h_1} |\mathbf{U}_1|^{h_2}\right) \\
 &= \frac{\Gamma_q\left(\frac{1}{2}(v_1 + v_2 + v_3)\right) \lambda^{-\frac{1}{2}qv_2 + qh_2}}{\prod_{i=1}^3 \Gamma_q\left(\frac{1}{2}v_i\right)} \beta_q\left(\frac{1}{2}v_3 + h_2, \frac{1}{2}(v_1 + v_2) - h_2\right) \\
 &\times \beta_q\left(\frac{1}{2}v_2 + h_1, \frac{1}{2}v_1 - h_1\right) |\lambda^{-1}\mathbf{I}_q|^{-\frac{1}{2}(v_1 + v_2) + h_2} \\
 &\times {}_2F_1\left(\frac{1}{2}v_1 - h_1, \frac{1}{2}(v_1 + v_2) - h_2; \frac{1}{2}(v_1 + v_2); \mathbf{I}_q - \lambda\mathbf{I}_q\right) \\
 &= \frac{\Gamma_q\left(\frac{1}{2}(v_1 + v_2 + v_3)\right) \lambda^{\frac{1}{2}qv_1}}{\prod_{i=1}^3 \Gamma_q\left(\frac{1}{2}v_i\right)} \frac{\Gamma_q\left(\frac{1}{2}v_3 + h_2\right) \Gamma_q\left(\frac{1}{2}(v_1 + v_2) - h_2\right)}{\Gamma_q\left(\frac{1}{2}(v_1 + v_2 + v_3)\right)} \\
 &\times \frac{\Gamma_q\left(\frac{1}{2}v_2 + h_1\right) \Gamma_q\left(\frac{1}{2}v_1 - h_1\right)}{\Gamma_q\left(\frac{1}{2}(v_1 + v_2)\right)} \\
 &\times {}_2F_1\left(\frac{1}{2}v_1 - h_1, \frac{1}{2}(v_1 + v_2) - h_2; \frac{1}{2}(v_1 + v_2); \mathbf{I}_q - \lambda\mathbf{I}_q\right) \\
 &= \frac{\Gamma_q\left(\frac{1}{2}(v_1 + v_2) - h_2\right) \Gamma_q\left(\frac{1}{2}v_3 + h_2\right) \Gamma_q\left(\frac{1}{2}v_1 - h_1\right) \Gamma_q\left(\frac{1}{2}v_2 + h_1\right)}{\prod_{i=1}^3 \Gamma_q\left(\frac{1}{2}v_i\right) \Gamma_q\left(\frac{1}{2}(v_1 + v_2)\right)} \lambda^{\frac{1}{2}qv_1} \\
 &\times {}_2F_1\left(\frac{1}{2}v_1 - h_1, \frac{1}{2}(v_1 + v_2) - h_2; \frac{1}{2}(v_1 + v_2); (1 - \lambda)\mathbf{I}_q\right).
 \end{aligned}$$

■

**Lemma 4.3.1** *The  $h^{th}$  moment of  $|\mathbf{U}_0|$  and  $|\mathbf{U}_1|$  where  $(\mathbf{U}_0, \mathbf{U}_1)$  is distributed as (4.5) can be obtained from (4.22):*

$$\begin{aligned}
 (a) \quad &E\left(|\mathbf{U}_0|^h\right) = \frac{\Gamma_q\left(\frac{1}{2}v_1 - h\right) \Gamma_q\left(\frac{1}{2}v_2 + h\right)}{\Gamma_q\left(\frac{1}{2}v_1\right) \Gamma_q\left(\frac{1}{2}v_2\right)} \lambda^{qh}
 \end{aligned} \tag{4.27}$$

where  $\text{Re}\left(\frac{1}{2}v_1 - h\right) > \frac{1}{2}(q - 1)$ ,  $\text{Re}\left(\frac{1}{2}v_2 + h\right) > \frac{1}{2}(q - 1)$ .

4. GENERALISED BIMATRIX VARIATE BETA TYPE II DISTRIBUTIONS  
 4.3. The generalised bimatrix variate beta type II distributions

---

(b)

$$E\left(|\mathbf{U}_1|^h\right) = \frac{\Gamma_q\left(\frac{1}{2}(v_1+v_2)-h\right)\Gamma_q\left(\frac{1}{2}v_3+h\right)\lambda^{\frac{1}{2}v_1q}}{\Gamma_q\left(\frac{1}{2}v_3\right)\Gamma_q\left(\frac{1}{2}(v_1+v_2)\right)} \quad (4.28)$$

$$\times {}_2F_1\left(\frac{1}{2}v_1, \frac{1}{2}(v_1+v_2)-h; \frac{1}{2}(v_1+v_2); (1-\lambda)\mathbf{I}_q\right)$$

where  $\|(1-\lambda)\mathbf{I}_q\| < 1$ ,  $\operatorname{Re}\left(\frac{1}{2}(v_1+v_2)-h\right) > \frac{1}{2}(q-1)$ ,  $\operatorname{Re}\left(\frac{1}{2}v_3+h\right) > \frac{1}{2}(q-1)$ .

**Proof.** (a) Set  $h_1 = h$  and  $h_2 = 0$  in (4.22) and using (C.51) it follows, then

$$E\left(|\mathbf{U}_0|^h\right) = \frac{\Gamma_q\left(\frac{1}{2}(v_1+v_2)\right)\Gamma_q\left(\frac{1}{2}v_3\right)\Gamma_q\left(\frac{1}{2}v_1-h\right)\Gamma_q\left(\frac{1}{2}v_2+h\right)\lambda^{\frac{1}{2}qv_1}}{\prod_{i=1}^3\Gamma_q\left(\frac{1}{2}v_i\right)\Gamma_q\left(\frac{1}{2}(v_1+v_2)\right)}$$

$$\times {}_2F_1\left(\frac{1}{2}v_1-h, \frac{1}{2}(v_1+v_2); \frac{1}{2}(v_1+v_2); (1-\lambda)\mathbf{I}_q\right)$$

$$= \frac{\Gamma_q\left(\frac{1}{2}v_1-h\right)\Gamma_q\left(\frac{1}{2}v_2+h\right)\lambda^{\frac{1}{2}qv_1}}{\Gamma_q\left(\frac{1}{2}v_1\right)\Gamma_q\left(\frac{1}{2}v_2\right)} {}_1F_0\left(\frac{1}{2}v_1-h; (1-\lambda)\mathbf{I}_q\right)$$

$$= \frac{\Gamma_q\left(\frac{1}{2}v_1-h\right)\Gamma_q\left(\frac{1}{2}v_2+h\right)\lambda^{\frac{1}{2}qv_1}}{\Gamma_q\left(\frac{1}{2}v_1\right)\Gamma_q\left(\frac{1}{2}v_2\right)} |\mathbf{I}_q - (1-\lambda)\mathbf{I}_q|^{-\left(\frac{1}{2}v_1-h\right)}$$

$$= \frac{\Gamma_q\left(\frac{1}{2}v_1-h\right)\Gamma_q\left(\frac{1}{2}v_2+h\right)}{\Gamma_q\left(\frac{1}{2}v_1\right)\Gamma_q\left(\frac{1}{2}v_2\right)} \lambda^{qh}.$$

(b) Set  $h_1 = 0$  and  $h_2 = h$  in (4.22), then

$$E\left(|\mathbf{U}_1|^h\right) = \frac{\Gamma_q\left(\frac{1}{2}(v_1+v_2)-h\right)\Gamma_q\left(\frac{1}{2}v_3+h\right)\Gamma_q\left(\frac{1}{2}v_1\right)\Gamma_q\left(\frac{1}{2}v_2\right)\lambda^{\frac{1}{2}qv_1}}{\prod_{i=1}^3\Gamma_q\left(\frac{1}{2}v_i\right)\Gamma_q\left(\frac{1}{2}(v_1+v_2)\right)}$$

$$\times {}_2F_1\left(\frac{1}{2}v_1, \frac{1}{2}(v_1+v_2)-h; \frac{1}{2}(v_1+v_2); (1-\lambda)\mathbf{I}_q\right)$$

$$= \frac{\Gamma_q\left(\frac{1}{2}(v_1+v_2)-h\right)\Gamma_q\left(\frac{1}{2}v_3+h\right)\lambda^{\frac{1}{2}qv_1}}{\Gamma_q\left(\frac{1}{2}v_3\right)\Gamma_q\left(\frac{1}{2}(v_1+v_2)\right)}$$

$$\times {}_2F_1\left(\frac{1}{2}v_1, \frac{1}{2}(v_1+v_2)-h; \frac{1}{2}(v_1+v_2); (1-\lambda)\mathbf{I}_q\right).$$

■

#### 4.3.1.4 Distributions of $|\mathbf{U}_0|$ , $|\mathbf{U}_1|$ and $|\mathbf{U}_0\mathbf{U}_1|$

Exact expressions for the pdfs of  $|\mathbf{U}_0|$ ,  $|\mathbf{U}_1|$  and  $|\mathbf{U}_0\mathbf{U}_1|$  are derived in Theorem 4.4. Note that the expressions of the cumulative distribution function of  $|\mathbf{U}_0|$  and  $|\mathbf{U}_1|$  are included - see Chapter 5, Section 5.3.



## 4. GENERALISED BIMATRIX VARIATE BETA TYPE II DISTRIBUTIONS

### 4.3. The generalised bimatrix variate beta type II distributions

**Theorem 4.4** Suppose that  $\mathbf{X} \sim W_q(v_1, \Sigma)$  is independent of  $\mathbf{W}_0 \sim W_q(v_2, \lambda\Sigma)$  and  $\mathbf{W}_1 \sim W_q(v_3, \lambda\Sigma)$ . If the joint pdf of (4.2) is given by (4.5) with marginal pdfs given in (4.14) and (4.15) respectively, then

(a) the pdf of  $|\mathbf{U}_0|$  is given by

$$f(|\mathbf{U}_0|) = \frac{\pi^{\frac{q(q-1)}{2}}}{\Gamma_q(\frac{1}{2}v_1)\Gamma_q(\frac{1}{2}v_2)} \lambda^{-q} G_{q,q}^{q,q} \left( \lambda^{-q} |\mathbf{U}_0| \begin{matrix} a_1, \dots, a_q \\ b_1, \dots, b_q \end{matrix} \right), \quad (4.29)$$

$$|\mathbf{U}_0| > 0,$$

(b) with cumulative distribution function (CDF)

$$F_{|\mathbf{U}_0|}(c) = \Pr(|\mathbf{U}_0| \leq c)$$

$$= \frac{\pi^{\frac{q(q-1)}{2}}}{\Gamma_q(\frac{1}{2}v_1)\Gamma_q(\frac{1}{2}v_2)} G_{q+1,q+1}^{q,q+1} \left( \lambda^{-q} c \begin{matrix} 1, a_1+1, \dots, a_q+1 \\ b_1+1, \dots, b_q+1, 0 \end{matrix} \right), \quad c > 0, \quad (4.30)$$

where  $G(\cdot)$  denotes Meijer's  $G$ -function (see (B.16)) and

$$a_j = -\frac{1}{2}v_1 + \frac{1}{2}(j-1) \text{ and } b_j = \frac{1}{2}v_2 - \frac{1}{2}(j+1) \text{ for } j = 1, 2, \dots, q.$$

(c) The pdf of  $|\mathbf{U}_1|$  is given by

$$f(|\mathbf{U}_1|) = \frac{\lambda^{\frac{1}{2}v_1q} \pi^{\frac{q(q-1)}{2}}}{\Gamma_q(\frac{1}{2}v_1)\Gamma_q(\frac{1}{2}v_3)} \quad (4.31)$$

$$\times \sum_{t=0}^{\infty} \sum_{\tau} \frac{\Gamma_q(\frac{1}{2}v_1, \tau)}{\Gamma_q(\frac{1}{2}(v_1+v_2), \tau) t!} (1-\lambda)^t C_{\tau}(\mathbf{I}_q) G_{q,q}^{q,q} \left( |\mathbf{U}_1| \begin{matrix} a_1, \dots, a_q \\ b_1, \dots, b_q \end{matrix} \right),$$

$$|\mathbf{U}_1| > 0,$$

with the values of the parameters such that  $f(|\mathbf{U}_1|)$  is a valid pdf,

(d) with CDF

$$F_{|\mathbf{U}_1|}(c) = \Pr(|\mathbf{U}_1| \leq c)$$

$$= \frac{\lambda^{\frac{1}{2}v_1q} \pi^{\frac{q(q-1)}{2}}}{\Gamma_q(\frac{1}{2}v_1)\Gamma_q(\frac{1}{2}v_3)} \quad (4.32)$$

$$\times \sum_{t=0}^{\infty} \sum_{\tau} \frac{\Gamma_q(\frac{1}{2}v_1, \tau)}{\Gamma_q(\frac{1}{2}(v_1+v_2), \tau) t!} (1-\lambda)^t C_{\tau}(\mathbf{I}_q) G_{q+1,q+1}^{q,q+1} \left( c \begin{matrix} 1, a_1+1, \dots, a_q+1 \\ b_1+1, \dots, b_q+1, 0 \end{matrix} \right),$$

$$c > 0,$$

## 4. GENERALISED BIMATRIX VARIATE BETA TYPE II DISTRIBUTIONS

### 4.3. The generalised bimatrix variate beta type II distributions

where  $a_j = -\frac{1}{2}(v_1 + v_2) - t_j + \frac{1}{2}(j - 1)$  and  $b_j = \frac{1}{2}v_3 - \frac{1}{2}(j + 1)$  for  $j = 1, \dots, q$ , with the values of the parameters such that  $F_{|\mathbf{U}_1|}(c)$  is a valid CDF and  $\Gamma_q(\cdot, \cdot)$  denotes the generalised gamma function (see (C.40)) and  $C_\tau(\cdot)$  is the zonal polynomial defined in (C.43).

(e) The pdf of  $|\mathbf{U}_0\mathbf{U}_1|$  is given by

$$f(|\mathbf{U}_0\mathbf{U}_1|) = \frac{\lambda^{\frac{1}{2}qv_1}}{\Gamma_q\left(\frac{1}{2}v_1\right)\Gamma_q\left(\frac{1}{2}v_2\right)\Gamma_q\left(\frac{1}{2}v_3\right)} \quad (4.33)$$

$$\times \sum_{t=0}^{\infty} \sum_{\tau} \frac{\pi^{q(q-1)}(1-\lambda)^t C_\tau(\mathbf{I}_q)}{\Gamma_q\left(\frac{1}{2}(v_1+v_2), \tau\right) t!} G_{2q,2q}^{2q,2q}\left(|\mathbf{U}_0\mathbf{U}_1| \Big|_{b_1, \dots, b_{2q}}^{a_1, \dots, a_{2q}}\right),$$

$$|\mathbf{U}_0\mathbf{U}_1| > 0,$$

where

$$a_j = \begin{cases} -\frac{1}{2}v_1 - t_{\frac{j+1}{2}} + \frac{1}{4}(j-1) & \text{for } j = 1, 3, \dots, 2q-1 \\ -\frac{1}{2}(v_1+v_2) - t_{\frac{j}{2}} + \frac{1}{4}(j-2) & \text{for } j = 2, 4, \dots, 2q, \end{cases}$$

$$b_j = \begin{cases} \frac{1}{2}v_3 - 1 - \frac{(j-1)}{4} & \text{for } j = 1, 3, \dots, 2q-1 \\ \frac{1}{2}v_2 - 1 - \frac{(j-2)}{4} & \text{for } j = 2, 4, \dots, 2q, \end{cases}$$

with the values of the parameters such that  $f(|\mathbf{U}_0\mathbf{U}_1|)$  is a valid pdf.

**Proof.** (a) From (4.27),

$$E\left(|\mathbf{U}_0|^{h-1}\right) = \frac{\Gamma_q\left(\frac{1}{2}v_1 - h + 1\right)\Gamma_q\left(\frac{1}{2}v_2 + h - 1\right)}{\Gamma_q\left(\frac{1}{2}v_1\right)\Gamma_q\left(\frac{1}{2}v_2\right)} \lambda^{q(h-1)},$$

therefore

$$E\left(|\lambda^{-1}\mathbf{U}_0|^{h-1}\right) = \frac{\Gamma_q\left(\frac{1}{2}v_1 - h + 1\right)\Gamma_q\left(\frac{1}{2}v_2 + h - 1\right)}{\Gamma_q\left(\frac{1}{2}v_1\right)\Gamma_q\left(\frac{1}{2}v_2\right)}. \quad (4.34)$$

The Mellin transform (see (B.14)) of  $f(|\lambda^{-1}\mathbf{U}_0|)$  is

$$M_f(h) \equiv E\left(|\lambda^{-1}\mathbf{U}_0|^{h-1}\right). \quad (4.35)$$

Expressing the multivariate gamma functions in (4.34) as a product of gamma functions (see (C.35)) and substituting it in the Mellin transform (4.35), gives

$$M_f(h) = \frac{\pi^{\frac{q(q-1)}{2}} \prod_{j=1}^q \Gamma[1 - a_j - h] \prod_{j=1}^q \Gamma[b_j + h]}{\Gamma_q\left(\frac{1}{2}v_1\right)\Gamma_q\left(\frac{1}{2}v_2\right)}, \quad (4.36)$$

where  $a_j = -\frac{1}{2}v_1 + \frac{1}{2}(j-1)$  and  $b_j = \frac{1}{2}v_2 - \frac{1}{2}(j+1)$ ,  $j = 1, 2, \dots, q$ .

## 4. GENERALISED BIMATRIX VARIATE BETA TYPE II DISTRIBUTIONS

### 4.3. The generalised bimatrix variate beta type II distributions

---

The pdf of  $|\lambda^{-1}\mathbf{U}_0|$  is uniquely obtained from the inverse Mellin transform (see (B.15)) of (4.36) and the definition of the Meijer's G-function (see (B.16)) and is given by

$$\begin{aligned}
& f(|\lambda^{-1}\mathbf{U}_0|) \\
&= \frac{1}{2\pi i} \int_{\omega-i\infty}^{\omega+i\infty} M_f(h) |\lambda^{-1}\mathbf{U}_0|^{-h} dh \\
&= \frac{\pi^{\frac{q(q-1)}{2}}}{\Gamma_q(\frac{1}{2}v_1) \Gamma_q(\frac{1}{2}v_2)} \frac{1}{2\pi i} \int_{\omega-i\infty}^{\omega+i\infty} \prod_{j=1}^q \Gamma[1 - a_j - h] \prod_{j=1}^q \Gamma[b_j + h] |\lambda^{-1}\mathbf{U}_0|^{-h} dh \\
&= \frac{\pi^{\frac{q(q-1)}{2}}}{\Gamma_q(\frac{1}{2}v_1) \Gamma_q(\frac{1}{2}v_2)} G_{q,q}^{q,q} \left( \lambda^{-q} |\mathbf{U}_0| \middle|_{b_1, \dots, b_q}^{a_1, \dots, a_q} \right). \tag{4.37}
\end{aligned}$$

Therefore

$$f(|\mathbf{U}_0|) = \frac{\pi^{\frac{q(q-1)}{2}}}{\Gamma_q(\frac{1}{2}v_1) \Gamma_q(\frac{1}{2}v_2)} \lambda^{-q} G_{q,q}^{q,q} \left( \lambda^{-q} |\mathbf{U}_0| \middle|_{b_1, \dots, b_q}^{a_1, \dots, a_q} \right).$$

(b) Let  $u = |\mathbf{U}_0|$ ,  $u > 0$  then from (4.29) the CDF is defined as

$$\begin{aligned}
F_{|\mathbf{U}_0|}(c) &= \Pr(|\mathbf{U}_0| \leq c) \\
&= \frac{\pi^{\frac{q(q-1)}{2}}}{\Gamma_q(\frac{1}{2}v_1) \Gamma_q(\frac{1}{2}v_2)} \lambda^{-q} \int_0^c G_{q,q}^{q,q} \left( \lambda^{-q} u \middle|_{b_1, \dots, b_q}^{a_1, \dots, a_q} \right) du.
\end{aligned}$$

Applying (B.27), (B.28) and (B.25), yields the desired result:

$$\begin{aligned}
F_{|\mathbf{U}_0|}(c) &= \frac{\pi^{\frac{q(q-1)}{2}}}{\Gamma_q(\frac{1}{2}v_1) \Gamma_q(\frac{1}{2}v_2)} \lambda^{-q} \int_0^c H_{q,q}^{q,q} \left( \lambda^{-q} u \middle|_{(b_1,1), \dots, (b_q,1)}^{(a_1,1), \dots, (a_q,1)} \right) du \\
&= \frac{\pi^{\frac{q(q-1)}{2}}}{\Gamma_q(\frac{1}{2}v_1) \Gamma_q(\frac{1}{2}v_2)} \lambda^{-q} {}_cH_{q+1,q+1}^{q,q+1} \left( \lambda^{-q} c \middle|_{(b_1,1), \dots, (b_q,1), (-1,1)}^{(0,1), (a_1,1), \dots, (a_q,1)} \right) \\
&= \frac{\pi^{\frac{q(q-1)}{2}}}{\Gamma_q(\frac{1}{2}v_1) \Gamma_q(\frac{1}{2}v_2)} \lambda^{-q} {}_cG_{q+1,q+1}^{q,q+1} \left( \lambda^{-q} c \middle|_{b_1, \dots, b_q, -1}^{0, a_1, \dots, a_q} \right) \\
&= \frac{\pi^{\frac{q(q-1)}{2}}}{\Gamma_q(\frac{1}{2}v_1) \Gamma_q(\frac{1}{2}v_2)} G_{q+1,q+1}^{q,q+1} \left( \lambda^{-q} c \middle|_{b_1+1, \dots, b_q+1, 0}^{1, a_1+1, \dots, a_q+1} \right).
\end{aligned}$$

(c) From (4.28) the Mellin transform (see (B.14)) of  $f(|\mathbf{U}_1|)$  is

$$\begin{aligned}
M_f(h) &\equiv E(|\mathbf{U}_1|^{h-1}) \\
&= \frac{\Gamma_q(\frac{1}{2}(v_1 + v_2) - h + 1) \Gamma_q(\frac{1}{2}v_3 + h - 1) \lambda^{\frac{1}{2}v_1q}}{\Gamma_q(\frac{1}{2}v_3) \Gamma_q(\frac{1}{2}(v_1 + v_2))} \\
&\quad \times {}_2F_1\left(\frac{1}{2}v_1, \frac{1}{2}(v_1 + v_2) - h + 1; \frac{1}{2}(v_1 + v_2); (1 - \lambda) \mathbf{I}_q\right). \tag{4.38}
\end{aligned}$$

## 4. GENERALISED BIMATRIX VARIATE BETA TYPE II DISTRIBUTIONS

### 4.3. The generalised bimatrix variate beta type II distributions

Using (C.49) and (C.40) the Gauss hypergeometric function of matrix argument in (4.38) can be written as

$$\begin{aligned}
 & {}_2F_1\left(\frac{1}{2}v_1, \frac{1}{2}(v_1 + v_2) - h + 1; \frac{1}{2}(v_1 + v_2); (1 - \lambda) \mathbf{I}_q\right) \\
 &= \sum_{t=0}^{\infty} \sum_{\tau} \frac{\left(\frac{1}{2}v_1\right)_{\tau} \left(\frac{1}{2}(v_1 + v_2) - h + 1\right)_{\tau} C_{\tau}((1 - \lambda) \mathbf{I}_q)}{\left(\frac{1}{2}(v_1 + v_2)\right)_{\tau} t!} \\
 &= \sum_{t=0}^{\infty} \sum_{\tau} \frac{\Gamma_q\left(\frac{1}{2}v_1, \tau\right) \Gamma_q\left(\frac{1}{2}(v_1 + v_2) - h + 1, \tau\right) \Gamma_q\left(\frac{1}{2}(v_1 + v_2)\right) C_{\tau}((1 - \lambda) \mathbf{I}_q)}{\Gamma_q\left(\frac{1}{2}v_1\right) \Gamma_q\left(\frac{1}{2}(v_1 + v_2) - h + 1\right) \Gamma_q\left(\frac{1}{2}(v_1 + v_2), \tau\right) t!}.
 \end{aligned}$$

This gives

$$\begin{aligned}
 M_f(h) &\equiv \frac{\Gamma_q\left(\frac{1}{2}v_3 + h - 1\right) \lambda^{\frac{1}{2}v_1 q}}{\Gamma_q\left(\frac{1}{2}v_1\right) \Gamma_q\left(\frac{1}{2}v_3\right)} \\
 &\quad \times \sum_{t=0}^{\infty} \sum_{\tau} \frac{\Gamma_q\left(\frac{1}{2}v_1, \tau\right) \Gamma_q\left(\frac{1}{2}(v_1 + v_2) - h + 1, \tau\right)}{\Gamma_q\left(\frac{1}{2}(v_1 + v_2), \tau\right) t!} C_{\tau}((1 - \lambda) \mathbf{I}_q).
 \end{aligned} \tag{4.39}$$

From (C.35) the multivariate gamma function in (4.39) can be written as

$$\Gamma_q\left(\frac{1}{2}v_3 + h - 1\right) = \pi^{\frac{q(q-1)}{4}} \prod_{j=1}^q \Gamma[b_j + h], \tag{4.40}$$

where  $b_j = \frac{1}{2}v_3 - \frac{1}{2}(j + 1)$  for  $j = 1, \dots, q$ ,

and using (C.39), the generalised gamma function of weight  $\tau$  can be written as

$$\Gamma_q\left(\frac{1}{2}(v_1 + v_2) - h + 1, \tau\right) = \pi^{\frac{q(q-1)}{4}} \prod_{j=1}^q \Gamma[1 - a_j - h], \tag{4.41}$$

where  $a_j = -\frac{1}{2}(v_1 + v_2) - t_j + \frac{1}{2}(j - 1)$  for  $j = 1, 2, \dots, q$ .

Substituting (4.40) and (4.41) in (4.39) gives

$$\begin{aligned}
 M_f(h) &\equiv \frac{\lambda^{\frac{1}{2}v_1 q}}{\Gamma_q\left(\frac{1}{2}v_1\right) \Gamma_q\left(\frac{1}{2}v_3\right)} \sum_{t=0}^{\infty} \sum_{\tau} \frac{\Gamma_q\left(\frac{1}{2}v_1, \tau\right)}{\Gamma_q\left(\frac{1}{2}(v_1 + v_2), \tau\right) t!} \pi^{\frac{q(q-1)}{2}} \\
 &\quad \times \prod_{j=1}^q \Gamma[1 - a_j - h] \prod_{j=1}^q \Gamma[b_j + h] C_{\tau}((1 - \lambda) \mathbf{I}_q).
 \end{aligned} \tag{4.42}$$

## 4. GENERALISED BIMATRIX VARIATE BETA TYPE II DISTRIBUTIONS

### 4.3. The generalised bimatrix variate beta type II distributions

The pdf of  $|\mathbf{U}_1|$  is obtained from the inverse Mellin transform (see (B.15)) of (4.42) and from the definition of the Meijer's G-function (see (B.16)) as

$$\begin{aligned}
 f(|\mathbf{U}_1|) &= \frac{1}{2\pi i} \int_{\omega-i\infty}^{\omega+i\infty} M_f(h) |\mathbf{U}_1|^{-h} dh \\
 &= \frac{\lambda^{\frac{1}{2}v_1q}}{\Gamma_q\left(\frac{1}{2}v_1\right) \Gamma_q\left(\frac{1}{2}v_3\right)} \sum_{t=0}^{\infty} \sum_{\tau} \frac{\Gamma_q\left(\frac{1}{2}v_1, \tau\right)}{\Gamma_q\left(\frac{1}{2}(v_1+v_2), \tau\right) t!} C_{\tau}((1-\lambda)\mathbf{I}_q) \pi^{\frac{q(q-1)}{2}} \\
 &\quad \times \frac{1}{2\pi i} \int_{\omega-i\infty}^{\omega+i\infty} \prod_{j=1}^q \Gamma[1-a_j-h] \prod_{j=1}^q \Gamma[b_j+h] |\mathbf{U}_1|^{-h} dh \\
 &= \frac{\lambda^{\frac{1}{2}v_1q} \pi^{\frac{q(q-1)}{2}}}{\Gamma_q\left(\frac{1}{2}v_1\right) \Gamma_q\left(\frac{1}{2}v_3\right)} \sum_{t=0}^{\infty} \sum_{\tau} \frac{\Gamma_q\left(\frac{1}{2}v_1, \tau\right)}{\Gamma_q\left(\frac{1}{2}(v_1+v_2), \tau\right) t!} (1-\lambda)^t C_{\tau}(\mathbf{I}_q) G_{q,q}^{q,q}\left(|\mathbf{U}_1| \middle|_{b_1, \dots, b_q}^{a_1, \dots, a_q}\right).
 \end{aligned}$$

(d) Let  $u = |\mathbf{U}_1|$ ,  $u > 0$  then from (4.31) the CDF is defined as

$$\begin{aligned}
 F_{|\mathbf{U}_1|}(c) &= \Pr(|\mathbf{U}_1| \leq c) \\
 &= \frac{\lambda^{\frac{1}{2}v_1q} \pi^{\frac{q(q-1)}{2}}}{\Gamma_q\left(\frac{1}{2}v_1\right) \Gamma_q\left(\frac{1}{2}v_3\right)} \\
 &\quad \times \sum_{t=0}^{\infty} \sum_{\tau} \frac{\Gamma_q\left(\frac{1}{2}v_1, \tau\right)}{\Gamma_q\left(\frac{1}{2}(v_1+v_2), \tau\right) t!} (1-\lambda)^t C_{\tau}(\mathbf{I}_q) \int_0^c G_{q,q}^{q,q}\left(u \middle|_{b_1, \dots, b_q}^{a_1, \dots, a_q}\right) du.
 \end{aligned}$$

Applying (B.27), (B.28) and (B.25), yields the desired result:

$$\begin{aligned}
 F_{|\mathbf{U}_1|}(c) &= \frac{\lambda^{\frac{1}{2}v_1q} \pi^{\frac{q(q-1)}{2}}}{\Gamma_q\left(\frac{1}{2}v_1\right) \Gamma_q\left(\frac{1}{2}v_3\right)} \\
 &\quad \times \sum_{t=0}^{\infty} \sum_{\tau} \frac{\Gamma_q\left(\frac{1}{2}v_1, \tau\right)}{\Gamma_q\left(\frac{1}{2}(v_1+v_2), \tau\right) t!} (1-\lambda)^t C_{\tau}(\mathbf{I}_q) \int_0^c H_{q,q}^{q,q}\left(v \middle|_{(b_1,1), \dots, (b_q,1)}^{(a_1,1), \dots, (a_q,1)}\right) du \\
 &= \frac{\lambda^{\frac{1}{2}v_1q} \pi^{\frac{q(q-1)}{2}}}{\Gamma_q\left(\frac{1}{2}v_1\right) \Gamma_q\left(\frac{1}{2}v_3\right)} \\
 &\quad \times \sum_{t=0}^{\infty} \sum_{\tau} \frac{\Gamma_q\left(\frac{1}{2}v_1, \tau\right)}{\Gamma_q\left(\frac{1}{2}(v_1+v_2), \tau\right) t!} (1-\lambda)^t C_{\tau}(\mathbf{I}_q) c H_{q+1,q+1}^{q,q+1}\left(c \middle|_{(b_1,1), \dots, (b_q,1), (-1,1)}^{(0,1), (a_1,1), \dots, (a_q,1)}\right) \\
 &= \frac{\lambda^{\frac{1}{2}v_1q} \pi^{\frac{q(q-1)}{2}}}{\Gamma_q\left(\frac{1}{2}v_1\right) \Gamma_q\left(\frac{1}{2}v_3\right)} \\
 &\quad \times \sum_{t=0}^{\infty} \sum_{\tau} \frac{\Gamma_q\left(\frac{1}{2}v_1, \tau\right)}{\Gamma_q\left(\frac{1}{2}(v_1+v_2), \tau\right) t!} (1-\lambda)^t C_{\tau}(\mathbf{I}_q) c G_{q+1,q+1}^{q,q+1}\left(c \middle|_{b_1, \dots, b_q, -1}^{0, a_1, \dots, a_q}\right)
 \end{aligned}$$

#### 4. GENERALISED BIMATRIX VARIATE BETA TYPE II DISTRIBUTIONS

##### 4.3. The generalised bimatrix variate beta type II distributions

$$\begin{aligned}
 &= \frac{\lambda^{\frac{1}{2}v_1q} \pi^{\frac{q(q-1)}{2}}}{\Gamma_q\left(\frac{1}{2}v_1\right) \Gamma_q\left(\frac{1}{2}v_3\right)} \\
 &\quad \times \sum_{t=0}^{\infty} \sum_{\tau} \frac{\Gamma_q\left(\frac{1}{2}v_1, \tau\right)}{\Gamma_q\left(\frac{1}{2}(v_1+v_2), \tau\right) t!} (1-\lambda)^t C_{\tau}(\mathbf{I}_q) G_{q+1, q+1}^{q, q+1} \left( c \middle|_{b_1+1, \dots, b_q+1, 0}^{1, a_1+1, \dots, a_q+1} \right).
 \end{aligned}$$

(e) From (4.22), (C.49) and (C.40) the Mellin transform (see (B.14)) of  $f(|\mathbf{U}_0\mathbf{U}_1|)$  is

$$\begin{aligned}
 &M_f(h) \\
 &\equiv E\left(|\mathbf{U}_0\mathbf{U}_1|^{h-1}\right) \\
 &= \frac{\Gamma_q\left(\frac{1}{2}(v_1+v_2)-h+1\right) \Gamma_q\left(\frac{1}{2}v_3+h-1\right) \Gamma_q\left(\frac{1}{2}v_1-h+1\right) \Gamma_q\left(\frac{1}{2}v_2+h-1\right) \lambda^{\frac{1}{2}qv_1}}{\prod_{i=1}^3 \Gamma_q\left(\frac{1}{2}v_i\right) \Gamma_q\left(\frac{1}{2}(v_1+v_2)\right)} \\
 &\quad \times {}_2F_1\left(\frac{1}{2}v_1-h+1, \frac{1}{2}(v_1+v_2)-h+1; \frac{1}{2}(v_1+v_2); (1-\lambda)\mathbf{I}_q\right) \\
 &= \frac{\Gamma_q\left(\frac{1}{2}(v_1+v_2)-h+1\right) \Gamma_q\left(\frac{1}{2}v_3+h-1\right) \Gamma_q\left(\frac{1}{2}v_1-h+1\right) \Gamma_q\left(\frac{1}{2}v_2+h-1\right) \lambda^{\frac{1}{2}qv_1}}{\prod_{i=1}^3 \Gamma_q\left(\frac{1}{2}v_i\right) \Gamma_q\left(\frac{1}{2}(v_1+v_2)\right)} \\
 &\quad \times \sum_{t=0}^{\infty} \sum_{\tau} \frac{\left(\frac{1}{2}v_1-h+1\right)_{\tau} \left(\frac{1}{2}(v_1+v_2)-h+1\right)_{\tau} C_{\tau}((1-\lambda)\mathbf{I}_q)}{\left(\frac{1}{2}(v_1+v_2)\right)_{\tau} t!} \\
 &= \frac{\Gamma_q\left(\frac{1}{2}(v_1+v_2)-h+1\right) \Gamma_q\left(\frac{1}{2}v_3+h-1\right) \Gamma_q\left(\frac{1}{2}v_1-h+1\right) \Gamma_q\left(\frac{1}{2}v_2+h-1\right) \lambda^{\frac{1}{2}qv_1}}{\prod_{i=1}^3 \Gamma_q\left(\frac{1}{2}v_i\right) \Gamma_q\left(\frac{1}{2}(v_1+v_2)\right)} \\
 &\quad \times \sum_{t=0}^{\infty} \sum_{\tau} \frac{\Gamma_q\left(\frac{1}{2}v_1-h+1, \tau\right) \Gamma_q\left(\frac{1}{2}(v_1+v_2)-h+1, \tau\right) \Gamma_q\left(\frac{1}{2}(v_1+v_2)\right)}{\Gamma_q\left(\frac{1}{2}v_1-h+1\right) \Gamma_q\left(\frac{1}{2}(v_1+v_2)-h+1\right) \Gamma_q\left(\frac{1}{2}(v_1+v_2), \tau\right)} \\
 &\quad \times \frac{C_{\tau}((1-\lambda)\mathbf{I}_q)}{t!} \\
 &= \frac{\Gamma_q\left(\frac{1}{2}v_3+h-1\right) \Gamma_q\left(\frac{1}{2}v_2+h-1\right) \lambda^{\frac{1}{2}qv_1}}{\Gamma_q\left(\frac{1}{2}v_1\right) \Gamma_q\left(\frac{1}{2}v_2\right) \Gamma_q\left(\frac{1}{2}v_3\right)} \\
 &\quad \times \sum_{t=0}^{\infty} \sum_{\tau} \frac{\Gamma_q\left(\frac{1}{2}v_1-h+1, \tau\right) \Gamma_q\left(\frac{1}{2}(v_1+v_2)-h+1, \tau\right)}{\Gamma_q\left(\frac{1}{2}(v_1+v_2), \tau\right) t!} C_{\tau}((1-\lambda)\mathbf{I}_q). \tag{4.43}
 \end{aligned}$$

From (C.35) the multivariate gamma functions in (4.43) can be written as

$$\begin{aligned}
 &\Gamma_q\left(\frac{1}{2}v_3+h-1\right) \Gamma_q\left(\frac{1}{2}v_2+h-1\right) \\
 &= \pi^{\frac{q(q-1)}{2}} \prod_{j=1}^q \Gamma\left[\frac{1}{2}v_3+h-1-\frac{(j-1)}{2}\right] \prod_{j=1}^q \Gamma\left[\frac{1}{2}v_2+h-1-\frac{(j-1)}{2}\right]
 \end{aligned}$$

## 4. GENERALISED BIMATRIX VARIATE BETA TYPE II DISTRIBUTIONS

### 4.3. The generalised bimatrix variate beta type II distributions

$$= \pi^{\frac{q(q-1)}{2}} \prod_{j=1}^{2q} \Gamma [b_j + h], \quad (4.44)$$

$$\text{where } b_j = \begin{cases} \frac{1}{2}v_3 - 1 - \frac{(j-1)}{4} & \text{for } j = 1, 3, \dots, 2q - 1 \\ \frac{1}{2}v_2 - 1 - \frac{(j-2)}{4} & \text{for } j = 2, 4, \dots, 2q. \end{cases}$$

Using (C.39) the generalised gamma function of weight  $\tau$  can be written as

$$\begin{aligned} & \Gamma_q \left( \frac{1}{2}v_1 - h + 1, \tau \right) \Gamma_q \left( \frac{1}{2} (v_1 + v_2) - h + 1, \tau \right) \\ &= \pi^{\frac{q(q-1)}{2}} \prod_{j=1}^q \Gamma \left[ \frac{1}{2}v_1 - h + 1 + t_j - \frac{1}{2} (j - 1) \right] \prod_{j=1}^q \Gamma \left[ \frac{1}{2} (v_1 + v_2) - h + 1 + t_j - \frac{1}{2} (j - 1) \right] \\ &= \pi^{\frac{q(q-1)}{2}} \prod_{j=1}^{2q} \Gamma [1 - a_j - h], \end{aligned} \quad (4.45)$$

$$\text{where } a_j = \begin{cases} -\frac{1}{2}v_1 - t_{\frac{j+1}{2}} + \frac{1}{4} (j - 1) & \text{for } j = 1, 3, \dots, 2q - 1 \\ -\frac{1}{2} (v_1 + v_2) - t_{\frac{j}{2}} + \frac{1}{4} (j - 2) & \text{for } j = 2, 4, \dots, 2q. \end{cases}$$

Substituting (4.44) and (4.45) in (4.43) gives

$$\begin{aligned} M_f(h) &\equiv \frac{\lambda^{\frac{1}{2}qv_1}}{\Gamma_q \left( \frac{1}{2}v_1 \right) \Gamma_q \left( \frac{1}{2}v_2 \right) \Gamma_q \left( \frac{1}{2}v_3 \right)} \\ &\times \sum_{t=0}^{\infty} \sum_{\tau} \frac{\pi^{q(q-1)} \prod_{j=1}^{2q} \Gamma [1 - a_j - h] \prod_{j=1}^{2q} \Gamma [b_j + h]}{\Gamma_q \left( \frac{1}{2} (v_1 + v_2), \tau \right) t!} C_{\tau} ((1 - \lambda) \mathbf{I}_q). \end{aligned} \quad (4.46)$$

The pdf of  $|\mathbf{U}_0 \mathbf{U}_1|$  is obtained from the inverse Mellin transform (see (B.15)) of (4.46) and from the definition of the Meijer's G-function (see (B.16)) as

$$\begin{aligned} & f(|\mathbf{U}_0 \mathbf{U}_1|) \\ &= \frac{1}{2\pi i} \int_{\omega-i\infty}^{\omega+i\infty} M_f(h) (|\mathbf{U}_0 \mathbf{U}_1|)^{-h} dh \\ &= \frac{\lambda^{\frac{1}{2}qv_1}}{\Gamma_q \left( \frac{1}{2}v_1 \right) \Gamma_q \left( \frac{1}{2}v_2 \right) \Gamma_q \left( \frac{1}{2}v_3 \right)} \sum_{t=0}^{\infty} \sum_{\tau} \frac{\pi^{q(q-1)} C_{\tau} ((1 - \lambda) \mathbf{I}_q)}{\Gamma_q \left( \frac{1}{2} (v_1 + v_2), \tau \right) t!} \\ &\quad \times \frac{1}{2\pi i} \int_{\omega-i\infty}^{\omega+i\infty} \prod_{j=1}^{2q} \Gamma [1 - a_j - h] \prod_{j=1}^{2q} \Gamma [b_j + h] (|\mathbf{U}_0 \mathbf{U}_1|)^{-h} dh \\ &= \frac{\lambda^{\frac{1}{2}qv_1}}{\Gamma_q \left( \frac{1}{2}v_1 \right) \Gamma_q \left( \frac{1}{2}v_2 \right) \Gamma_q \left( \frac{1}{2}v_3 \right)} \sum_{t=0}^{\infty} \sum_{\tau} \frac{\pi^{q(q-1)} (1 - \lambda)^t C_{\tau} (\mathbf{I}_q)}{\Gamma_q \left( \frac{1}{2} (v_1 + v_2), \tau \right) t!} G_{2q,2q}^{2q,2q} \left( |\mathbf{U}_0 \mathbf{U}_1| \middle| \begin{matrix} a_1, \dots, a_{2q} \\ b_1, \dots, b_{2q} \end{matrix} \right). \end{aligned}$$

■

#### 4. GENERALISED BIMATRIX VARIATE BETA TYPE II DISTRIBUTIONS

##### 4.3. The generalised bimatrix variate beta type II distributions

**Remark 4.2** Substituting  $q=1$  in (4.29) and using (B.26) yields the marginal pdf of  $U_0$  given in (2.24):

$$\begin{aligned}
 f(u_0) &= \frac{1}{\Gamma\left(\frac{1}{2}v_1\right)\Gamma\left(\frac{1}{2}v_2\right)} \lambda^{-1} G_{1,1}^{1,1} \left( \lambda^{-1} u_0 \middle| \frac{-\frac{1}{2}v_1}{\frac{1}{2}v_2-1} \right) \\
 &= \frac{1}{\Gamma\left(\frac{1}{2}v_1\right)\Gamma\left(\frac{1}{2}v_2\right)} \lambda^{-1} \frac{(\lambda^{-1})^{\frac{1}{2}v_2-1} \Gamma\left(\frac{1}{2}(v_1+v_2)\right) u_0^{\frac{1}{2}v_2-1}}{(1+\lambda^{-1}u_0)^{\frac{1}{2}(v_1+v_2)}} \\
 &= \frac{\Gamma\left(\frac{1}{2}(v_1+v_2)\right)}{\Gamma\left(\frac{1}{2}v_1\right)\Gamma\left(\frac{1}{2}v_2\right)} \lambda^{-\frac{1}{2}v_2} u_0^{\frac{1}{2}v_2-1} [\lambda^{-1}(\lambda+u_0)]^{-\frac{1}{2}(v_1+v_2)} \\
 &= \frac{\Gamma\left(\frac{1}{2}(v_1+v_2)\right)}{\Gamma\left(\frac{1}{2}v_1\right)\Gamma\left(\frac{1}{2}v_2\right)} \lambda^{\frac{1}{2}v_1} u_0^{\frac{1}{2}v_2-1} (\lambda+u_0)^{-\frac{1}{2}(v_1+v_2)}, \quad u_0 > 0.
 \end{aligned}$$

**Remark 4.3** Substituting  $q=1$  in (4.31) using (C.40) and (B.26) yields the marginal pdf of  $U_1$  given in (2.25):

$$\begin{aligned}
 f(u_1) &= \frac{\lambda^{\frac{1}{2}v_1}}{\Gamma\left(\frac{1}{2}v_1\right)\Gamma\left(\frac{1}{2}v_3\right)} \sum_{t=0}^{\infty} \frac{\Gamma_1\left(\frac{1}{2}v_1, t\right)}{\Gamma_1\left(\frac{1}{2}(v_1+v_2), t\right) t!} (1-\lambda)^t C_t(\mathbf{I}_1) G_{1,1}^{1,1} \left( u_1 \middle| \frac{-\frac{1}{2}(v_1+v_2)-t}{\frac{1}{2}v_3-1} \right) \\
 &= \frac{\lambda^{\frac{1}{2}v_1}}{\Gamma\left(\frac{1}{2}v_1\right)\Gamma\left(\frac{1}{2}v_3\right)} \sum_{t=0}^{\infty} \frac{\left(\frac{1}{2}v_1\right)_t \Gamma\left(\frac{1}{2}v_1\right)}{\left(\frac{1}{2}(v_1+v_2)\right)_t \Gamma\left(\frac{1}{2}(v_1+v_2)\right) t!} (1-\lambda)^t \\
 &\quad \times \frac{\Gamma\left(\frac{1}{2}(v_1+v_2+v_3)+t\right) u_1^{\frac{1}{2}v_3-1}}{(1+u_1)^{\frac{1}{2}(v_1+v_2+v_3)+t}} \\
 &= \frac{\lambda^{\frac{1}{2}v_1}}{\Gamma\left(\frac{1}{2}v_3\right)\Gamma\left(\frac{1}{2}(v_1+v_2)\right)} u_1^{\frac{1}{2}v_3-1} (1+u_1)^{-\frac{1}{2}(v_1+v_2+v_3)} \sum_{t=0}^{\infty} \frac{\left(\frac{1}{2}v_1\right)_t}{\left(\frac{1}{2}(v_1+v_2)\right)_t t!} \left(\frac{1-\lambda}{1+u_1}\right)^t \\
 &\quad \times \Gamma\left(\frac{1}{2}(v_1+v_2+v_3)+t\right) \\
 &= \frac{\Gamma\left(\frac{1}{2}(v_1+v_2+v_3)\right) \lambda^{\frac{1}{2}v_1}}{\Gamma\left(\frac{1}{2}v_3\right)\Gamma\left(\frac{1}{2}(v_1+v_2)\right)} u_1^{\frac{1}{2}v_3-1} (1+u_1)^{-\frac{1}{2}(v_1+v_2+v_3)} \\
 &\quad \times \sum_{t=0}^{\infty} \frac{\left(\frac{1}{2}v_1\right)_t \left(\frac{1}{2}(v_1+v_2+v_3)\right)_t}{\left(\frac{1}{2}(v_1+v_2)\right)_t t!} \left(\frac{1-\lambda}{1+u_1}\right)^t \\
 &= \frac{\Gamma\left(\frac{1}{2}(v_1+v_2+v_3)\right) \lambda^{\frac{1}{2}v_1}}{\Gamma\left(\frac{1}{2}v_3\right)\Gamma\left(\frac{1}{2}(v_1+v_2)\right)} u_1^{\frac{1}{2}v_3-1} (1+u_1)^{-\frac{1}{2}(v_1+v_2+v_3)} \\
 &\quad \times {}_2F_1\left(\frac{1}{2}v_1, \frac{1}{2}(v_1+v_2+v_3); \frac{1}{2}(v_1+v_2); \frac{1-\lambda}{1+u_1}\right), \quad u_1 > 0, \quad \left|\frac{1-\lambda}{1+u_1}\right| < 1.
 \end{aligned}$$

**Remark 4.4** Pham-Gia and Turkkan (2011) [40] discussed the two kinds of Wilks' statistic. If  $\mathbf{U}_0 = \mathbf{X}^{-\frac{1}{2}} \mathbf{W}_0 \mathbf{X}^{-\frac{1}{2}}$  with  $\mathbf{X}$  and  $\mathbf{W}_0$  Wishart matrices ( $W_q(v_i, \Sigma)$ ,  $i = 1, 2$ ), then  $\mathbf{U}_0$  has the matrix variate beta type II distribution. They derived the exact expression for



## 4. GENERALISED BIMATRIX VARIATE BETA TYPE II DISTRIBUTIONS

### 4.3. The generalised bimatrix variate beta type II distributions

the pdf of Wilks' statistic type II:  $|\mathbf{U}_0|$ , the latter expressed as the product of  $q$  univariate betas of the second kind, which in turn, can be expressed as Meijer  $G$ -functions. Thus, (4.29) and (4.31) can be considered as Wilks' type II statistics.

#### 4.3.2 The covariance structure change from $\Sigma$ to $\Sigma_1$

In this section the generalised bimatrix variate beta type II distribution is derived for the case where the covariance structure of the multivariate normal process changes from  $\Sigma$  to  $\Sigma_1$ , i.e. not just a scale transformation. The difference between this scenario and the one discussed in Section 4.3.1 is evident from the comparison of the contour plots of the multivariate normal distribution for the bivariate case ( $q = 2$ ) given in Figure 4.2 and Figure 4.3 respectively. This section is organised in the same way as Section 4.3.1 where the pdf  $(\mathbf{U}_0, \mathbf{U}_1)$  (4.2) is derived in Section 4.3.2.1 and the marginal pdfs in Section 4.3.2.2 for the case where the covariance matrix change to  $\Sigma_1$  instead of  $\lambda\Sigma$ . In Sections 4.3.2.3 and 4.3.2.4 exact expressions for the moments and product moment and the pdfs of  $|\mathbf{U}_0|$ ,  $|\mathbf{U}_1|$  and  $|\mathbf{U}_0\mathbf{U}_1|$  are derived, respectively.

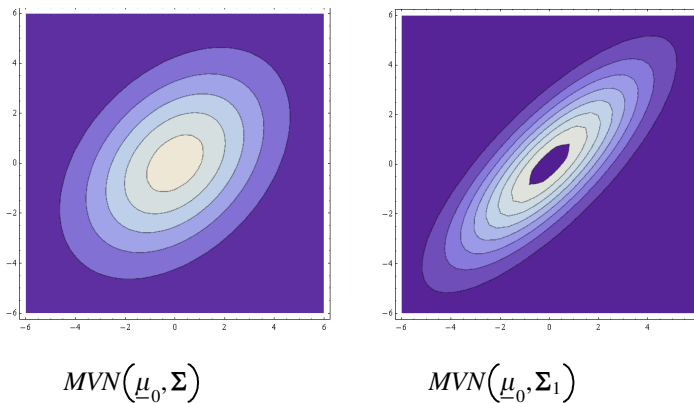

**Figure 4.3** Contour plot to illustrate the effect of a change of the covariance matrix

##### 4.3.2.1 The probability density function

In this section the joint pdf of the generalised bimatrix variate beta type II distribution is derived for the general case where the change in the covariance structure of the multivariate normal distribution of the process is not restricted to a scale factor only.

## 4. GENERALISED BIMATRIX VARIATE BETA TYPE II DISTRIBUTIONS

### 4.3. The generalised bimatrix variate beta type II distributions

---

**Theorem 4.5** *Suppose that  $\mathbf{X} \sim W_q(v_1, \boldsymbol{\Sigma})$  is independent of  $\mathbf{W}_0 \sim W_q(v_2, \boldsymbol{\Sigma}_1)$  and  $\mathbf{W}_1 \sim W_q(v_3, \boldsymbol{\Sigma}_1)$ . Then the pdf of (4.2) is given by*

$$\begin{aligned}
 f(\mathbf{U}_0, \mathbf{U}_1) & \tag{4.47} \\
 &= \frac{\Gamma_q\left(\frac{1}{2}(v_1 + v_2 + v_3)\right)}{\prod_{i=1}^3 \Gamma_q\left(\frac{1}{2}v_i\right) |\boldsymbol{\Sigma}|^{\frac{1}{2}v_1} |\boldsymbol{\Sigma}_1|^{\frac{1}{2}(v_2+v_3)}} |\mathbf{U}_0|^{\frac{1}{2}v_2 - \frac{1}{2}(q+1)} |\mathbf{U}_1|^{\frac{1}{2}v_3 - \frac{1}{2}(q+1)} |\mathbf{I}_q + \mathbf{U}_0|^{\frac{1}{2}v_3} \\
 & \quad \times \left| \boldsymbol{\Sigma}^{-1} + \mathbf{U}_0^{\frac{1}{2}} \boldsymbol{\Sigma}_1^{-1} \mathbf{U}_0^{\frac{1}{2}} + (\mathbf{I}_q + \mathbf{U}_0)^{\frac{1}{2}} \boldsymbol{\Sigma}_1^{-\frac{1}{2}} \mathbf{U}_1 \boldsymbol{\Sigma}_1^{-\frac{1}{2}} (\mathbf{I}_q + \mathbf{U}_0)^{\frac{1}{2}} \right|^{-\frac{1}{2}(v_1+v_2+v_3)},
 \end{aligned}$$

where  $\mathbf{U}_i > \mathbf{0}$ , with  $\text{Re}(v_i) > q - 1$ ,  $i = 1, 2, 3$ .

**Proof.** The joint pdf of  $\mathbf{X}$ ,  $\mathbf{W}_0$  and  $\mathbf{W}_1$  is given by (see (C.59))

$$\begin{aligned}
 f(\mathbf{X}, \mathbf{W}_0, \mathbf{W}_1) &= C |\mathbf{X}|^{\frac{1}{2}(v_1-q-1)} |\mathbf{W}_0|^{\frac{1}{2}(v_2-q-1)} |\mathbf{W}_1|^{\frac{1}{2}(v_3-q-1)} \tag{4.48} \\
 & \quad \times \text{etr}\left(-\frac{1}{2}\boldsymbol{\Sigma}^{-1}\mathbf{X}\right) \text{etr}\left(-\frac{1}{2}\boldsymbol{\Sigma}_1^{-1}\mathbf{W}_0\right) \text{etr}\left(-\frac{1}{2}\boldsymbol{\Sigma}_1^{-1}\mathbf{W}_1\right),
 \end{aligned}$$

where

$$C^{-1} = 2^{\frac{1}{2}q(v_1+v_2+v_3)} \prod_{i=1}^3 \Gamma_q\left(\frac{1}{2}v_i\right) |\boldsymbol{\Sigma}|^{\frac{1}{2}v_1} |\boldsymbol{\Sigma}_1|^{\frac{1}{2}(v_2+v_3)}. \tag{4.49}$$

The transformation

$$\mathbf{U} = \mathbf{X}, \quad \mathbf{U}_0 = \mathbf{X}^{-\frac{1}{2}} \mathbf{W}_0 \mathbf{X}^{-\frac{1}{2}}, \quad \mathbf{U}_1 = (\mathbf{X} + \mathbf{W}_0)^{-\frac{1}{2}} \mathbf{W}_1 (\mathbf{X} + \mathbf{W}_0)^{-\frac{1}{2}},$$

give

$$\begin{aligned}
 \mathbf{X} = \mathbf{U}, \quad \mathbf{W}_0 &= \mathbf{U}^{\frac{1}{2}} \mathbf{U}_0 \mathbf{U}^{\frac{1}{2}}, \quad \mathbf{W}_1 = \left(\mathbf{U} + \mathbf{U}^{\frac{1}{2}} \mathbf{U}_0 \mathbf{U}^{\frac{1}{2}}\right)^{\frac{1}{2}} \mathbf{U}_1 \left(\mathbf{U} + \mathbf{U}^{\frac{1}{2}} \mathbf{U}_0 \mathbf{U}^{\frac{1}{2}}\right)^{\frac{1}{2}} \\
 &= \left(\mathbf{U}^{\frac{1}{2}} (\mathbf{I}_q + \mathbf{U}_0) \mathbf{U}^{\frac{1}{2}}\right)^{\frac{1}{2}} \mathbf{U}_1 \left(\mathbf{U}^{\frac{1}{2}} (\mathbf{I}_q + \mathbf{U}_0) \mathbf{U}^{\frac{1}{2}}\right)^{\frac{1}{2}},
 \end{aligned}$$

with Jacobian (see (4.8))

$$J(\mathbf{X}, \mathbf{W}_0, \mathbf{W}_1 \rightarrow \mathbf{U}, \mathbf{U}_0, \mathbf{U}_1) = |\mathbf{U}|^{q+1} |\mathbf{I}_q + \mathbf{U}_0|^{\frac{1}{2}(q+1)}.$$

## 4. GENERALISED BIMATRIX VARIATE BETA TYPE II DISTRIBUTIONS

### 4.3. The generalised bimatrix variate beta type II distributions

---

Substituting in (4.48), the joint pdf of  $(\mathbf{U}, \mathbf{U}_0, \mathbf{U}_1)$  is

$$\begin{aligned}
 & f(\mathbf{U}, \mathbf{U}_0, \mathbf{U}_1) \\
 &= C |\mathbf{U}|^{\frac{1}{2}(v_1-q-1)} \left| \mathbf{U}^{\frac{1}{2}} \mathbf{U}_0 \mathbf{U}^{\frac{1}{2}} \right|^{\frac{1}{2}(v_2-q-1)} \left| \left( \mathbf{U}^{\frac{1}{2}} (\mathbf{I}_q + \mathbf{U}_0) \mathbf{U}^{\frac{1}{2}} \right)^{\frac{1}{2}} \mathbf{U}_1 \left( \mathbf{U}^{\frac{1}{2}} (\mathbf{I}_q + \mathbf{U}_0) \mathbf{U}^{\frac{1}{2}} \right)^{\frac{1}{2}} \right|^{\frac{1}{2}(v_3-q-1)} \\
 &\quad \times \text{etr}\left(-\frac{1}{2}\boldsymbol{\Sigma}^{-1}\mathbf{U}\right) \text{etr}\left(-\frac{1}{2}\boldsymbol{\Sigma}_1^{-1}\mathbf{U}^{\frac{1}{2}}\mathbf{U}_0\mathbf{U}^{\frac{1}{2}}\right) \\
 &\quad \times \text{etr}\left(-\frac{1}{2}\boldsymbol{\Sigma}_1^{-1}\left(\mathbf{U}^{\frac{1}{2}}(\mathbf{I}_q+\mathbf{U}_0)\mathbf{U}^{\frac{1}{2}}\right)^{\frac{1}{2}}\mathbf{U}_1\left(\mathbf{U}^{\frac{1}{2}}(\mathbf{I}_q+\mathbf{U}_0)\mathbf{U}^{\frac{1}{2}}\right)^{\frac{1}{2}}\right) |\mathbf{U}|^{q+1} |\mathbf{I}_q + \mathbf{U}_0|^{\frac{1}{2}(q+1)} \\
 &= C |\mathbf{U}|^{\frac{1}{2}(v_1+v_2+v_3)-\frac{1}{2}(q+1)} |\mathbf{U}_0|^{\frac{1}{2}v_2-\frac{1}{2}(q+1)} |\mathbf{U}_1|^{\frac{1}{2}v_3-\frac{1}{2}(q+1)} |\mathbf{I}_q + \mathbf{U}_0|^{\frac{1}{2}v_3} \\
 &\quad \times \text{etr}\left(-\frac{1}{2}\boldsymbol{\Sigma}^{-1}\mathbf{U}\right) \text{etr}\left(-\frac{1}{2}\boldsymbol{\Sigma}_1^{-1}\mathbf{U}^{\frac{1}{2}}\mathbf{U}_0\mathbf{U}^{\frac{1}{2}}\right) \\
 &\quad \times \text{etr}\left(-\frac{1}{2}\boldsymbol{\Sigma}_1^{-1}\left(\mathbf{U}^{\frac{1}{2}}(\mathbf{I}_q+\mathbf{U}_0)\mathbf{U}^{\frac{1}{2}}\right)^{\frac{1}{2}}\mathbf{U}_1\left(\mathbf{U}^{\frac{1}{2}}(\mathbf{I}_q+\mathbf{U}_0)\mathbf{U}^{\frac{1}{2}}\right)^{\frac{1}{2}}\right). \tag{4.50}
 \end{aligned}$$

From (4.50) follows that

$$\begin{aligned}
 & f(\mathbf{U}_0, \mathbf{U}_1) \\
 &= C |\mathbf{U}_0|^{\frac{1}{2}v_2-\frac{1}{2}(q+1)} |\mathbf{U}_1|^{\frac{1}{2}v_3-\frac{1}{2}(q+1)} |\mathbf{I}_q + \mathbf{U}_0|^{\frac{1}{2}v_3} \int_{\mathbf{U}>\mathbf{0}} |\mathbf{U}|^{\frac{1}{2}(v_1+v_2+v_3)-\frac{1}{2}(q+1)} \\
 &\quad \times \text{etr}\left(-\frac{1}{2}\boldsymbol{\Sigma}^{-1}\mathbf{U}\right) \text{etr}\left(-\frac{1}{2}\boldsymbol{\Sigma}_1^{-1}\mathbf{U}^{\frac{1}{2}}\mathbf{U}_0\mathbf{U}^{\frac{1}{2}}\right) \\
 &\quad \times \text{etr}\left(-\frac{1}{2}\boldsymbol{\Sigma}_1^{-1}\left(\mathbf{U}^{\frac{1}{2}}(\mathbf{I}_q+\mathbf{U}_0)\mathbf{U}^{\frac{1}{2}}\right)^{\frac{1}{2}}\mathbf{U}_1\left(\mathbf{U}^{\frac{1}{2}}(\mathbf{I}_q+\mathbf{U}_0)\mathbf{U}^{\frac{1}{2}}\right)^{\frac{1}{2}}\right) d\mathbf{U} \\
 &= C |\mathbf{U}_0|^{\frac{1}{2}v_2-\frac{1}{2}(q+1)} |\mathbf{U}_1|^{\frac{1}{2}v_3-\frac{1}{2}(q+1)} |\mathbf{I}_q + \mathbf{U}_0|^{\frac{1}{2}v_3} g_4(\boldsymbol{\Sigma}_1^{-1}), \tag{4.52}
 \end{aligned}$$

where

$$\begin{aligned}
 g_4(\boldsymbol{\Sigma}_1^{-1}) &= \int_{\mathbf{U}>\mathbf{0}} |\mathbf{U}|^{\frac{1}{2}(v_1+v_2+v_3)-\frac{1}{2}(q+1)} \text{etr}\left(-\frac{1}{2}\boldsymbol{\Sigma}^{-1}\mathbf{U}\right) \text{etr}\left(-\frac{1}{2}\boldsymbol{\Sigma}_1^{-1}\mathbf{U}^{\frac{1}{2}}\mathbf{U}_0\mathbf{U}^{\frac{1}{2}}\right) \\
 &\quad \times \text{etr}\left(-\frac{1}{2}\boldsymbol{\Sigma}_1^{-1}\left(\mathbf{U}^{\frac{1}{2}}(\mathbf{I}_q+\mathbf{U}_0)\mathbf{U}^{\frac{1}{2}}\right)^{\frac{1}{2}}\mathbf{U}_1\left(\mathbf{U}^{\frac{1}{2}}(\mathbf{I}_q+\mathbf{U}_0)\mathbf{U}^{\frac{1}{2}}\right)^{\frac{1}{2}}\right) d\mathbf{U}.
 \end{aligned}$$

Expanding  $\text{etr}\left(-\frac{1}{2}\boldsymbol{\Sigma}_1^{-1}\mathbf{U}^{\frac{1}{2}}\mathbf{U}_0\mathbf{U}^{\frac{1}{2}}\right)$  and  $\text{etr}\left(-\frac{1}{2}\boldsymbol{\Sigma}_1^{-1}\left(\mathbf{U}^{\frac{1}{2}}(\mathbf{I}_q+\mathbf{U}_0)\mathbf{U}^{\frac{1}{2}}\right)^{\frac{1}{2}}\mathbf{U}_1\left(\mathbf{U}^{\frac{1}{2}}(\mathbf{I}_q+\mathbf{U}_0)\mathbf{U}^{\frac{1}{2}}\right)^{\frac{1}{2}}\right)$  in terms of the zonal polynomials using (C.50) and applying (C.46) it follows that for any  $\mathbf{H} \in O(q)$ ,  $g_4(\boldsymbol{\Sigma}_1^{-1}) = g_4(\mathbf{H}\boldsymbol{\Sigma}_1^{-1}\mathbf{H}')$  with

#### 4. GENERALISED BIMATRIX VARIATE BETA TYPE II DISTRIBUTIONS

##### 4.3. The generalised bimatrix variate beta type II distributions

$$\begin{aligned}
 & g_4(\mathbf{H}\Sigma_1^{-1}\mathbf{H}') \\
 &= \int_{\mathbf{U}>\mathbf{0}} |\mathbf{U}|^{\frac{1}{2}(v_1+v_2+v_3)-\frac{1}{2}(q+1)} \text{etr}\left(-\frac{1}{2}\Sigma^{-1}\mathbf{U}\right) \int_{O(q)} \text{etr}\left(-\frac{1}{2}\mathbf{H}\Sigma_1^{-1}\mathbf{H}'\mathbf{U}^{\frac{1}{2}}\mathbf{U}_0\mathbf{U}^{\frac{1}{2}}\right) \\
 & \quad \times \text{etr}\left(-\frac{1}{2}\mathbf{H}\Sigma_1^{-1}\mathbf{H}'\left(\mathbf{U}^{\frac{1}{2}}(\mathbf{I}_q+\mathbf{U}_0)\mathbf{U}^{\frac{1}{2}}\right)^{\frac{1}{2}}\mathbf{U}_1\left(\mathbf{U}^{\frac{1}{2}}(\mathbf{I}_q+\mathbf{U}_0)\mathbf{U}^{\frac{1}{2}}\right)^{\frac{1}{2}}\right) d\mathbf{H}d\mathbf{U} \\
 &= \int_{\mathbf{U}>\mathbf{0}} |\mathbf{U}|^{\frac{1}{2}(v_1+v_2+v_3)-\frac{1}{2}(q+1)} \text{etr}\left(-\frac{1}{2}\Sigma^{-1}\mathbf{U}\right) \sum_s \sum_\varsigma \sum_t \sum_\tau \frac{1}{t!} \frac{1}{s!} \int_{O(q)} C_\varsigma\left(-\frac{1}{2}\mathbf{H}\Sigma_1^{-1}\mathbf{H}'\mathbf{U}^{\frac{1}{2}}\mathbf{U}_0\mathbf{U}^{\frac{1}{2}}\right) \\
 & \quad \times C_\tau\left(-\frac{1}{2}\mathbf{H}\Sigma_1^{-1}\mathbf{H}'\left(\mathbf{U}^{\frac{1}{2}}(\mathbf{I}_q+\mathbf{U}_0)\mathbf{U}^{\frac{1}{2}}\right)^{\frac{1}{2}}\mathbf{U}_1\left(\mathbf{U}^{\frac{1}{2}}(\mathbf{I}_q+\mathbf{U}_0)\mathbf{U}^{\frac{1}{2}}\right)^{\frac{1}{2}}\right) d\mathbf{H}d\mathbf{U} \\
 &= \int_{\mathbf{U}>\mathbf{0}} |\mathbf{U}|^{\frac{1}{2}(v_1+v_2+v_3)-\frac{1}{2}(q+1)} \text{etr}\left(-\frac{1}{2}\Sigma^{-1}\mathbf{U}\right) \sum_s \sum_\varsigma \sum_t \sum_\tau \frac{1}{t!} \frac{1}{s!} \int_{O(q)} C_\varsigma\left(-\frac{1}{2}\mathbf{H}\Sigma_1^{-1}\mathbf{H}'\mathbf{U}^{\frac{1}{2}}\mathbf{U}_0\mathbf{U}^{\frac{1}{2}}\right) \\
 & \quad \times C_\tau\left(-\frac{1}{2}\mathbf{H}\Sigma_1^{-1}\mathbf{H}'\mathbf{U}_1^{\frac{1}{2}}\mathbf{U}^{\frac{1}{2}}(\mathbf{I}_q+\mathbf{U}_0)\mathbf{U}^{\frac{1}{2}}\mathbf{U}_1^{\frac{1}{2}}\right) d\mathbf{H}d\mathbf{U}.
 \end{aligned}$$

Applying (C.48) gives

$$\begin{aligned}
 & g_4(\mathbf{H}\Sigma_1^{-1}\mathbf{H}') \\
 &= \int_{\mathbf{U}>\mathbf{0}} |\mathbf{U}|^{\frac{1}{2}(v_1+v_2+v_3)-\frac{1}{2}(q+1)} \text{etr}\left(-\frac{1}{2}\Sigma^{-1}\mathbf{U}\right) \sum_s \sum_\varsigma \sum_t \sum_\tau \frac{1}{t!} \frac{1}{s!} \int_{O(q)} C_\varsigma\left(-\frac{1}{2}\mathbf{H}\Sigma_1^{-1}\mathbf{H}'\mathbf{U}_0^{\frac{1}{2}}\mathbf{U}\mathbf{U}_0^{\frac{1}{2}}\right) \\
 & \quad \times C_\tau\left(-\frac{1}{2}\mathbf{H}\Sigma_1^{-1}\mathbf{H}(\mathbf{I}_q+\mathbf{U}_0)^{\frac{1}{2}}\mathbf{U}^{\frac{1}{2}}\mathbf{U}_1\mathbf{U}^{\frac{1}{2}}(\mathbf{I}_q+\mathbf{U}_0)^{\frac{1}{2}}\right) d\mathbf{H}d\mathbf{U},
 \end{aligned}$$

and

$$\begin{aligned}
 g_4(\Sigma_1^{-1}) &= \int_{\mathbf{U}>\mathbf{0}} |\mathbf{U}|^{\frac{1}{2}(v_1+v_2+v_3)-\frac{1}{2}(q+1)} \text{etr}\left(-\frac{1}{2}\Sigma^{-1}\mathbf{U}\right) \text{etr}\left(-\frac{1}{2}\Sigma_1^{-1}\mathbf{U}_0^{\frac{1}{2}}\mathbf{U}\mathbf{U}_0^{\frac{1}{2}}\right) \\
 & \quad \times \text{etr}\left(-\frac{1}{2}\Sigma_1^{-1}(\mathbf{I}_q+\mathbf{U}_0)^{\frac{1}{2}}\mathbf{U}^{\frac{1}{2}}\mathbf{U}_1\mathbf{U}^{\frac{1}{2}}(\mathbf{I}_q+\mathbf{U}_0)^{\frac{1}{2}}\right) d\mathbf{U}.
 \end{aligned} \tag{4.53}$$

Substituting (4.53) in (4.52) gives

$$\begin{aligned}
 & f(\mathbf{U}_0, \mathbf{U}_1) \\
 &= C |\mathbf{U}_0|^{\frac{1}{2}v_2-\frac{1}{2}(q+1)} |\mathbf{U}_1|^{\frac{1}{2}v_3-\frac{1}{2}(q+1)} |\mathbf{I}_q+\mathbf{U}_0|^{\frac{1}{2}v_3} \int_{\mathbf{U}>\mathbf{0}} |\mathbf{U}|^{\frac{1}{2}(v_1+v_2+v_3)-\frac{1}{2}(q+1)} \text{etr}\left(-\frac{1}{2}\Sigma^{-1}\mathbf{U}\right) \\
 & \quad \times \text{etr}\left(-\frac{1}{2}\mathbf{U}_0^{\frac{1}{2}}\Sigma_1^{-1}\mathbf{U}_0^{\frac{1}{2}}\mathbf{U}\right) \text{etr}\left(-\frac{1}{2}(\mathbf{I}_q+\mathbf{U}_0)^{\frac{1}{2}}\Sigma_1^{-1}(\mathbf{I}_q+\mathbf{U}_0)^{\frac{1}{2}}\mathbf{U}^{\frac{1}{2}}\mathbf{U}_1\mathbf{U}^{\frac{1}{2}}\right) d\mathbf{U} \\
 &= C |\mathbf{U}_0|^{\frac{1}{2}v_2-\frac{1}{2}(q+1)} |\mathbf{U}_1|^{\frac{1}{2}v_3-\frac{1}{2}(q+1)} |\mathbf{I}_q+\mathbf{U}_0|^{\frac{1}{2}v_3} g_5(\mathbf{U}_1),
 \end{aligned} \tag{4.54}$$

## 4. GENERALISED BIMATRIX VARIATE BETA TYPE II DISTRIBUTIONS

### 4.3. The generalised bimatrix variate beta type II distributions

---

where

$$g_5(\mathbf{U}_1) = \int_{\mathbf{U} > \mathbf{0}} |\mathbf{U}|^{\frac{1}{2}(v_1+v_2+v_3)-\frac{1}{2}(q+1)} \text{etr}\left(-\frac{1}{2}\boldsymbol{\Sigma}^{-1}\mathbf{U}\right) \text{etr}\left(-\frac{1}{2}\boldsymbol{\Sigma}_1^{-1}\mathbf{U}_0^{\frac{1}{2}}\mathbf{U}\mathbf{U}_0^{\frac{1}{2}}\right) \\ \times \text{etr}\left(-\frac{1}{2}(\mathbf{I}_q + \mathbf{U}_0)^{\frac{1}{2}}\boldsymbol{\Sigma}_1^{-1}(\mathbf{I}_q + \mathbf{U}_0)^{\frac{1}{2}}\mathbf{U}^{\frac{1}{2}}\mathbf{U}_1\mathbf{U}^{\frac{1}{2}}\right) d\mathbf{U}.$$

Expanding  $\text{etr}\left(-\frac{1}{2}(\mathbf{I}_q + \mathbf{U}_0)^{\frac{1}{2}}\boldsymbol{\Sigma}_1^{-1}(\mathbf{I}_q + \mathbf{U}_0)^{\frac{1}{2}}\mathbf{U}^{\frac{1}{2}}\mathbf{U}_1\mathbf{U}^{\frac{1}{2}}\right)$  in terms of the zonal polynomial using (C.50) and applying (C.45) it follows that for any  $\mathbf{H} \in O(q)$ ,  $g_5(\mathbf{U}_1) = g_5(\mathbf{H}\mathbf{U}_1\mathbf{H}')$  with

$$g_5(\mathbf{H}\mathbf{U}_1\mathbf{H}') \\ = \int_{\mathbf{U} > \mathbf{0}} |\mathbf{U}|^{\frac{1}{2}(v_1+v_2+v_3)-\frac{1}{2}(q+1)} \text{etr}\left(-\frac{1}{2}\boldsymbol{\Sigma}^{-1}\mathbf{U}\right) \text{etr}\left(-\frac{1}{2}\mathbf{U}_0^{\frac{1}{2}}\boldsymbol{\Sigma}_1^{-1}\mathbf{U}_0^{\frac{1}{2}}\mathbf{U}\right) \\ \times \int_{O(q)} \text{etr}\left(-\frac{1}{2}(\mathbf{I}_q + \mathbf{U}_0)^{\frac{1}{2}}\boldsymbol{\Sigma}_1^{-1}(\mathbf{I}_q + \mathbf{U}_0)^{\frac{1}{2}}\mathbf{U}^{\frac{1}{2}}\mathbf{H}\mathbf{U}_1\mathbf{H}'\mathbf{U}^{\frac{1}{2}}\right) d\mathbf{H}d\mathbf{U} \\ = \int_{\mathbf{U} > \mathbf{0}} |\mathbf{U}|^{\frac{1}{2}(v_1+v_2+v_3)-\frac{1}{2}(q+1)} \text{etr}\left(-\frac{1}{2}\boldsymbol{\Sigma}^{-1}\mathbf{U}\right) \text{etr}\left(-\frac{1}{2}\mathbf{U}_0^{\frac{1}{2}}\boldsymbol{\Sigma}_1^{-1}\mathbf{U}_0^{\frac{1}{2}}\mathbf{U}\right) \\ \times \sum_t \sum_\tau \frac{1}{t!} \int_{O(q)} C_\tau\left(-\frac{1}{2}\mathbf{U}^{\frac{1}{2}}(\mathbf{I}_q + \mathbf{U}_0)^{\frac{1}{2}}\boldsymbol{\Sigma}_1^{-1}(\mathbf{I}_q + \mathbf{U}_0)^{\frac{1}{2}}\mathbf{U}^{\frac{1}{2}}\mathbf{H}\mathbf{U}_1\mathbf{H}'\right) d\mathbf{H}d\mathbf{U} \\ = \int_{\mathbf{U} > \mathbf{0}} |\mathbf{U}|^{\frac{1}{2}(v_1+v_2+v_3)-\frac{1}{2}(q+1)} \text{etr}\left(-\frac{1}{2}\boldsymbol{\Sigma}^{-1}\mathbf{U}\right) \text{etr}\left(-\frac{1}{2}\mathbf{U}_0^{\frac{1}{2}}\boldsymbol{\Sigma}_1^{-1}\mathbf{U}_0^{\frac{1}{2}}\mathbf{U}\right) \\ \times \sum_t \sum_\tau \frac{1}{t!} \int_{O(q)} C_\tau\left(-\frac{1}{2}\boldsymbol{\Sigma}_1^{-\frac{1}{2}}(\mathbf{I}_q + \mathbf{U}_0)^{\frac{1}{2}}\mathbf{U}(\mathbf{I}_q + \mathbf{U}_0)^{\frac{1}{2}}\boldsymbol{\Sigma}_1^{-\frac{1}{2}}\mathbf{H}\mathbf{U}_1\mathbf{H}'\right) d\mathbf{H}d\mathbf{U},$$

and

$$g_5(\mathbf{U}_1) \\ = \int_{\mathbf{U} > \mathbf{0}} |\mathbf{U}|^{\frac{1}{2}(v_1+v_2+v_3)-\frac{1}{2}(q+1)} \text{etr}\left(-\frac{1}{2}\boldsymbol{\Sigma}^{-1}\mathbf{U}\right) \text{etr}\left(-\frac{1}{2}\mathbf{U}_0^{\frac{1}{2}}\boldsymbol{\Sigma}_1^{-1}\mathbf{U}_0^{\frac{1}{2}}\mathbf{U}\right) \quad (4.55) \\ \times \text{etr}\left(-\frac{1}{2}\boldsymbol{\Sigma}_1^{-\frac{1}{2}}(\mathbf{I}_q + \mathbf{U}_0)^{\frac{1}{2}}\mathbf{U}(\mathbf{I}_q + \mathbf{U}_0)^{\frac{1}{2}}\boldsymbol{\Sigma}_1^{-\frac{1}{2}}\mathbf{U}_1\right) d\mathbf{U}.$$

## 4. GENERALISED BIMATRIX VARIATE BETA TYPE II DISTRIBUTIONS

### 4.3. The generalised bimatrix variate beta type II distributions

---

Substituting (4.55) in (4.54) gives

$$\begin{aligned}
 f(\mathbf{U}_0, \mathbf{U}_1) &= C |\mathbf{U}_0|^{\frac{1}{2}v_2 - \frac{1}{2}(q+1)} |\mathbf{U}_1|^{\frac{1}{2}v_3 - \frac{1}{2}(q+1)} |\mathbf{I}_q + \mathbf{U}_0|^{\frac{1}{2}v_3} \int_{\mathbf{U} > \mathbf{0}} |\mathbf{U}|^{\frac{1}{2}(v_1+v_2+v_3) - \frac{1}{2}(q+1)} \\
 &\quad \times \text{etr}\left(-\frac{1}{2}\boldsymbol{\Sigma}^{-1}\mathbf{U}\right) \text{etr}\left(-\frac{1}{2}\mathbf{U}_0^{\frac{1}{2}}\boldsymbol{\Sigma}_1^{-1}\mathbf{U}_0^{\frac{1}{2}}\mathbf{U}\right) \\
 &\quad \times \text{etr}\left(-\frac{1}{2}(\mathbf{I}_q + \mathbf{U}_0)^{\frac{1}{2}}\boldsymbol{\Sigma}_1^{-\frac{1}{2}}\mathbf{U}_1\boldsymbol{\Sigma}_1^{-\frac{1}{2}}(\mathbf{I}_q + \mathbf{U}_0)^{\frac{1}{2}}\mathbf{U}\right) d\mathbf{U} \\
 &= C |\mathbf{U}_0|^{\frac{1}{2}v_2 - \frac{1}{2}(q+1)} |\mathbf{U}_1|^{\frac{1}{2}v_3 - \frac{1}{2}(q+1)} |\mathbf{I}_q + \mathbf{U}_0|^{\frac{1}{2}v_3} \int_{\mathbf{U} > \mathbf{0}} |\mathbf{U}|^{\frac{1}{2}(v_1+v_2+v_3) - \frac{1}{2}(q+1)} \\
 &\quad \text{etr}\left(-\frac{1}{2}\left(\boldsymbol{\Sigma}^{-1} + \mathbf{U}_0^{\frac{1}{2}}\boldsymbol{\Sigma}_1^{-1}\mathbf{U}_0^{\frac{1}{2}} + (\mathbf{I}_q + \mathbf{U}_0)^{\frac{1}{2}}\boldsymbol{\Sigma}_1^{-\frac{1}{2}}\mathbf{U}_1\boldsymbol{\Sigma}_1^{-\frac{1}{2}}(\mathbf{I}_q + \mathbf{U}_0)^{\frac{1}{2}}\right)\mathbf{U}\right) d\mathbf{U}. \tag{4.56}
 \end{aligned}$$

Integrating (4.56) with respect to  $\mathbf{U}$  and substituting  $C$  (4.49) gives the desired result,

$$\begin{aligned}
 f(\mathbf{U}_0, \mathbf{U}_1) &= \frac{1}{2^{\frac{1}{2}q(v_1+v_2+v_3)} \prod_{i=1}^3 \Gamma_q\left(\frac{1}{2}v_i\right) |\boldsymbol{\Sigma}|^{\frac{1}{2}v_1} |\boldsymbol{\Sigma}_1|^{\frac{1}{2}(v_2+v_3)}} |\mathbf{U}_0|^{\frac{1}{2}v_2 - \frac{1}{2}(q+1)} |\mathbf{U}_1|^{\frac{1}{2}v_3 - \frac{1}{2}(q+1)} \\
 &\quad \times |\mathbf{I}_q + \mathbf{U}_0|^{\frac{1}{2}v_3} \Gamma_q\left(\frac{1}{2}(v_1 + v_2 + v_3)\right) \\
 &\quad \times \left| \frac{1}{2} \left( \boldsymbol{\Sigma}^{-1} + \mathbf{U}_0^{\frac{1}{2}}\boldsymbol{\Sigma}_1^{-1}\mathbf{U}_0^{\frac{1}{2}} + (\mathbf{I}_q + \mathbf{U}_0)^{\frac{1}{2}}\boldsymbol{\Sigma}_1^{-\frac{1}{2}}\mathbf{U}_1\boldsymbol{\Sigma}_1^{-\frac{1}{2}}(\mathbf{I}_q + \mathbf{U}_0)^{\frac{1}{2}} \right) \right|^{-\frac{1}{2}(v_1+v_2+v_3)} \\
 &= \frac{\Gamma_q\left(\frac{1}{2}(v_1 + v_2 + v_3)\right)}{\prod_{i=1}^3 \Gamma_q\left(\frac{1}{2}v_i\right) |\boldsymbol{\Sigma}|^{\frac{1}{2}v_1} |\boldsymbol{\Sigma}_1|^{\frac{1}{2}(v_2+v_3)}} |\mathbf{U}_0|^{\frac{1}{2}v_2 - \frac{1}{2}(q+1)} |\mathbf{U}_1|^{\frac{1}{2}v_3 - \frac{1}{2}(q+1)} |\mathbf{I}_q + \mathbf{U}_0|^{\frac{1}{2}v_3} \\
 &\quad \times \left| \boldsymbol{\Sigma}^{-1} + \mathbf{U}_0^{\frac{1}{2}}\boldsymbol{\Sigma}_1^{-1}\mathbf{U}_0^{\frac{1}{2}} + (\mathbf{I}_q + \mathbf{U}_0)^{\frac{1}{2}}\boldsymbol{\Sigma}_1^{-\frac{1}{2}}\mathbf{U}_1\boldsymbol{\Sigma}_1^{-\frac{1}{2}}(\mathbf{I}_q + \mathbf{U}_0)^{\frac{1}{2}} \right|^{-\frac{1}{2}(v_1+v_2+v_3)}.
 \end{aligned}$$

■

#### 4.3.2.2 Marginal probability density function

In this section the marginal pdfs of (4.47) are derived.

**Theorem 4.6** *Suppose that  $\mathbf{X} \sim W_q(v_1, \boldsymbol{\Sigma})$  is independent of  $\mathbf{W}_0 \sim W_q(v_2, \boldsymbol{\Sigma}_1)$  and  $\mathbf{W}_1 \sim W_q(v_3, \boldsymbol{\Sigma}_1)$ . If the joint pdf of (4.2) is given in (4.47), then the pdf of*

(a)  $\mathbf{U}_0$  is given by

$$f(\mathbf{U}_0) = \frac{\Gamma_q\left(\frac{1}{2}(v_1 + v_2)\right)}{\Gamma_q\left(\frac{1}{2}v_1\right) \Gamma_q\left(\frac{1}{2}v_2\right) |\boldsymbol{\Sigma}|^{\frac{1}{2}v_1} |\boldsymbol{\Sigma}_1|^{\frac{1}{2}v_2}} |\mathbf{U}_0|^{\frac{1}{2}v_2 - \frac{1}{2}(q+1)} \left| \boldsymbol{\Sigma}^{-1} + \boldsymbol{\Sigma}_1^{-\frac{1}{2}}\mathbf{U}_0\boldsymbol{\Sigma}_1^{-\frac{1}{2}} \right|^{-\frac{1}{2}(v_1+v_2)}, \tag{4.57}$$

where  $\mathbf{U}_0 > \mathbf{0}$ , with  $\text{Re}(v_i) > q - 1$ ,  $i = 1, 2$ .

4. GENERALISED BIMATRIX VARIATE BETA TYPE II DISTRIBUTIONS  
 4.3. The generalised bimatrix variate beta type II distributions

---

(b)  $\mathbf{U}_1$  is given by

$$\begin{aligned}
 f(\mathbf{U}_1) &= \frac{\Gamma_q\left(\frac{1}{2}(v_1 + v_2 + v_3)\right)}{\Gamma_q\left(\frac{1}{2}v_3\right)\Gamma_q\left(\frac{1}{2}(v_1 + v_2)\right)|\boldsymbol{\Sigma}|^{\frac{1}{2}v_1}|\boldsymbol{\Sigma}_1|^{\frac{1}{2}(v_2+v_3)}} \\
 &\times |\mathbf{U}_1|^{\frac{1}{2}v_3 - \frac{1}{2}(q+1)} \left| \boldsymbol{\Sigma}^{-1} + \mathbf{U}_1^{\frac{1}{2}} \boldsymbol{\Sigma}_1^{-1} \mathbf{U}_1^{\frac{1}{2}} \right|^{-\frac{1}{2}(v_1+v_2+v_3)} \\
 &\times {}_2F_1\left(\frac{1}{2}v_2, \frac{1}{2}(v_1 + v_2 + v_3); \frac{1}{2}(v_1 + v_2)\right) \\
 &\quad ; \mathbf{I}_q - \left(\boldsymbol{\Sigma}_1^{-1} + \mathbf{U}_1^{\frac{1}{2}} \boldsymbol{\Sigma}_1^{-1} \mathbf{U}_1^{\frac{1}{2}}\right)^{\frac{1}{2}} \left(\boldsymbol{\Sigma}^{-1} + \mathbf{U}_1^{\frac{1}{2}} \boldsymbol{\Sigma}_1^{-1} \mathbf{U}_1^{\frac{1}{2}}\right)^{-1} \left(\boldsymbol{\Sigma}_1^{-1} + \mathbf{U}_1^{\frac{1}{2}} \boldsymbol{\Sigma}_1^{-1} \mathbf{U}_1^{\frac{1}{2}}\right)^{\frac{1}{2}},
 \end{aligned} \tag{4.58}$$

where  $\mathbf{U}_1 > \mathbf{0}$ ,  $\left\| \mathbf{I}_q - \left(\boldsymbol{\Sigma}_1^{-1} + \mathbf{U}_1^{\frac{1}{2}} \boldsymbol{\Sigma}_1^{-1} \mathbf{U}_1^{\frac{1}{2}}\right)^{\frac{1}{2}} \left(\boldsymbol{\Sigma}^{-1} + \mathbf{U}_1^{\frac{1}{2}} \boldsymbol{\Sigma}_1^{-1} \mathbf{U}_1^{\frac{1}{2}}\right)^{-1} \left(\boldsymbol{\Sigma}_1^{-1} + \mathbf{U}_1^{\frac{1}{2}} \boldsymbol{\Sigma}_1^{-1} \mathbf{U}_1^{\frac{1}{2}}\right)^{\frac{1}{2}} \right\| < 1$   
 with  $\text{Re}(v_i) > q - 1, i = 1, 2, 3$ .

**Proof.** From (4.50) follows that

$$\begin{aligned}
 &f(\mathbf{U}_0) \\
 &= \int_{\mathbf{U}_1 > \mathbf{0}} \int_{\mathbf{U} > \mathbf{0}} C |\mathbf{U}|^{\frac{1}{2}(v_1+v_2+v_3) - \frac{1}{2}(q+1)} |\mathbf{U}_0|^{\frac{1}{2}v_2 - \frac{1}{2}(q+1)} |\mathbf{U}_1|^{\frac{1}{2}v_3 - \frac{1}{2}(q+1)} |\mathbf{I}_q + \mathbf{U}_0|^{\frac{1}{2}v_3} \\
 &\quad \times \text{etr}\left(-\frac{1}{2}\boldsymbol{\Sigma}^{-1}\mathbf{U}\right) \text{etr}\left(-\frac{1}{2}\boldsymbol{\Sigma}_1^{-1}\mathbf{U}^{\frac{1}{2}}\mathbf{U}_0\mathbf{U}^{\frac{1}{2}}\right) \\
 &\quad \times \text{etr}\left(-\frac{1}{2}\boldsymbol{\Sigma}_1^{-1}\left(\mathbf{U}^{\frac{1}{2}}(\mathbf{I}_q + \mathbf{U}_0)\mathbf{U}^{\frac{1}{2}}\right)^{\frac{1}{2}}\mathbf{U}_1\left(\mathbf{U}^{\frac{1}{2}}(\mathbf{I}_q + \mathbf{U}_0)\mathbf{U}^{\frac{1}{2}}\right)^{\frac{1}{2}}\right) d\mathbf{U}d\mathbf{U}_1 \\
 &= C |\mathbf{U}_0|^{\frac{1}{2}v_2 - \frac{1}{2}(q+1)} |\mathbf{I}_q + \mathbf{U}_0|^{\frac{1}{2}v_3} \int_{\mathbf{U} > \mathbf{0}} |\mathbf{U}|^{\frac{1}{2}(v_1+v_2+v_3) - \frac{1}{2}(q+1)} \text{etr}\left(-\frac{1}{2}\boldsymbol{\Sigma}^{-1}\mathbf{U}\right) \\
 &\quad \times \text{etr}\left(-\frac{1}{2}\boldsymbol{\Sigma}_1^{-1}\mathbf{U}^{\frac{1}{2}}\mathbf{U}_0\mathbf{U}^{\frac{1}{2}}\right) \int_{\mathbf{U}_1 > \mathbf{0}} |\mathbf{U}_1|^{\frac{1}{2}v_3 - \frac{1}{2}(q+1)} \\
 &\quad \times \text{etr}\left(-\frac{1}{2}\left(\mathbf{U}^{\frac{1}{2}}(\mathbf{I}_q + \mathbf{U}_0)\mathbf{U}^{\frac{1}{2}}\right)^{\frac{1}{2}}\boldsymbol{\Sigma}_1^{-1}\left(\mathbf{U}^{\frac{1}{2}}(\mathbf{I}_q + \mathbf{U}_0)\mathbf{U}^{\frac{1}{2}}\right)^{\frac{1}{2}}\mathbf{U}_1\right) d\mathbf{U}_1d\mathbf{U}.
 \end{aligned} \tag{4.59}$$

Integrating (4.59) with respect to  $\mathbf{U}_1$  using (C.54) gives

$$\begin{aligned}
 &f(\mathbf{U}_0) \\
 &= C |\mathbf{U}_0|^{\frac{1}{2}v_2 - \frac{1}{2}(q+1)} |\mathbf{I}_q + \mathbf{U}_0|^{\frac{1}{2}v_3} \int_{\mathbf{U} > \mathbf{0}} |\mathbf{U}|^{\frac{1}{2}(v_1+v_2+v_3) - \frac{1}{2}(q+1)} \text{etr}\left(-\frac{1}{2}\boldsymbol{\Sigma}^{-1}\mathbf{U}\right) \\
 &\quad \times \text{etr}\left(-\frac{1}{2}\boldsymbol{\Sigma}_1^{-1}\mathbf{U}^{\frac{1}{2}}\mathbf{U}_0\mathbf{U}^{\frac{1}{2}}\right) \\
 &\quad \times \Gamma_q\left(\frac{1}{2}v_3\right) \left| \frac{1}{2}\left(\mathbf{U}^{\frac{1}{2}}(\mathbf{I}_q + \mathbf{U}_0)\mathbf{U}^{\frac{1}{2}}\right)^{\frac{1}{2}}\boldsymbol{\Sigma}_1^{-1}\left(\mathbf{U}^{\frac{1}{2}}(\mathbf{I}_q + \mathbf{U}_0)\mathbf{U}^{\frac{1}{2}}\right)^{\frac{1}{2}} \right|^{-\frac{1}{2}v_3} d\mathbf{U}
 \end{aligned}$$

#### 4. GENERALISED BIMATRIX VARIATE BETA TYPE II DISTRIBUTIONS

##### 4.3. The generalised bimatrix variate beta type II distributions

---

$$\begin{aligned}
 &= C |\mathbf{U}_0|^{\frac{1}{2}v_2 - \frac{1}{2}(q+1)} |\mathbf{I}_q + \mathbf{U}_0|^{\frac{1}{2}v_3} \int_{\mathbf{U} > \mathbf{0}} |\mathbf{U}|^{\frac{1}{2}(v_1+v_2+v_3) - \frac{1}{2}(q+1)} \text{etr}\left(-\frac{1}{2}\boldsymbol{\Sigma}^{-1}\mathbf{U}\right) \\
 &\quad \times \text{etr}\left(-\frac{1}{2}\boldsymbol{\Sigma}_1^{-1}\mathbf{U}^{\frac{1}{2}}\mathbf{U}_0\mathbf{U}^{\frac{1}{2}}\right) \Gamma_q\left(\frac{1}{2}v_3\right) 2^{\frac{1}{2}qv_3} \left|\mathbf{U}^{\frac{1}{2}}(\mathbf{I}_q + \mathbf{U}_0)\mathbf{U}^{\frac{1}{2}}\right|^{-\frac{1}{2}v_3} |\boldsymbol{\Sigma}_1|^{\frac{1}{2}v_3} d\mathbf{U} \\
 &= C \Gamma_q\left(\frac{1}{2}v_3\right) 2^{\frac{1}{2}qv_3} |\mathbf{U}_0|^{\frac{1}{2}v_2 - \frac{1}{2}(q+1)} |\boldsymbol{\Sigma}_1|^{\frac{1}{2}v_3} \\
 &\quad \times \int_{\mathbf{U} > \mathbf{0}} |\mathbf{U}|^{\frac{1}{2}(v_1+v_2) - \frac{1}{2}(q+1)} \text{etr}\left(-\frac{1}{2}\boldsymbol{\Sigma}^{-1}\mathbf{U}\right) \text{etr}\left(-\frac{1}{2}\mathbf{U}^{\frac{1}{2}}\boldsymbol{\Sigma}_1^{-1}\mathbf{U}^{\frac{1}{2}}\mathbf{U}_0\right) d\mathbf{U} \\
 &= C \Gamma_q\left(\frac{1}{2}v_3\right) 2^{\frac{1}{2}qv_3} |\mathbf{U}_0|^{\frac{1}{2}v_2 - \frac{1}{2}(q+1)} |\boldsymbol{\Sigma}_1|^{\frac{1}{2}v_3} g_6(\mathbf{U}_0), \tag{4.60}
 \end{aligned}$$

where

$$g_6(\mathbf{U}_0) = \int_{\mathbf{U} > \mathbf{0}} |\mathbf{U}|^{\frac{1}{2}(v_1+v_2) - \frac{1}{2}(q+1)} \text{etr}\left(-\frac{1}{2}\boldsymbol{\Sigma}^{-1}\mathbf{U}\right) \text{etr}\left(-\frac{1}{2}\mathbf{U}^{\frac{1}{2}}\boldsymbol{\Sigma}_1^{-1}\mathbf{U}^{\frac{1}{2}}\mathbf{U}_0\right) d\mathbf{U}.$$

Expanding  $\text{etr}\left(-\frac{1}{2}\mathbf{U}^{\frac{1}{2}}\boldsymbol{\Sigma}_1^{-1}\mathbf{U}^{\frac{1}{2}}\mathbf{U}_0\right)$  in terms of the zonal polynomial using (C.50) and applying (C.44) it follows that for any  $\mathbf{H} \in O(q)$ ,  $g_6(\mathbf{U}_0) = g_6(\mathbf{H}\mathbf{U}_0\mathbf{H}')$  with

$$\begin{aligned}
 &g_6(\mathbf{H}\mathbf{U}_0\mathbf{H}') \\
 &= \int_{\mathbf{U} > \mathbf{0}} |\mathbf{U}|^{\frac{1}{2}(v_1+v_2) - \frac{1}{2}(q+1)} \text{etr}\left(-\frac{1}{2}\boldsymbol{\Sigma}^{-1}\mathbf{U}\right) \int_{O(q)} \text{etr}\left(-\frac{1}{2}\mathbf{U}^{\frac{1}{2}}\boldsymbol{\Sigma}_1^{-1}\mathbf{U}^{\frac{1}{2}}\mathbf{H}\mathbf{U}_0\mathbf{H}'\right) d\mathbf{H}d\mathbf{U} \\
 &= \int_{\mathbf{U} > \mathbf{0}} |\mathbf{U}|^{\frac{1}{2}(v_1+v_2) - \frac{1}{2}(q+1)} \text{etr}\left(-\frac{1}{2}\boldsymbol{\Sigma}^{-1}\mathbf{U}\right) \sum_t \sum_\tau \frac{1}{t!} \int_{O(q)} C_\tau\left(-\frac{1}{2}\mathbf{U}^{\frac{1}{2}}\boldsymbol{\Sigma}_1^{-1}\mathbf{U}^{\frac{1}{2}}\mathbf{H}\mathbf{U}_0\mathbf{H}'\right) d\mathbf{H}d\mathbf{U} \\
 &= \int_{\mathbf{U} > \mathbf{0}} |\mathbf{U}|^{\frac{1}{2}(v_1+v_2) - \frac{1}{2}(q+1)} \text{etr}\left(-\frac{1}{2}\boldsymbol{\Sigma}^{-1}\mathbf{U}\right) \sum_t \sum_\tau \frac{1}{t!} \int_{O(q)} C_\tau\left(-\frac{1}{2}\boldsymbol{\Sigma}_1^{-\frac{1}{2}}\mathbf{U}\boldsymbol{\Sigma}_1^{-\frac{1}{2}}\mathbf{H}\mathbf{U}_0\mathbf{H}'\right) d\mathbf{H}d\mathbf{U},
 \end{aligned}$$

and

$$g_6(\mathbf{U}_0) = \int_{\mathbf{U} > \mathbf{0}} |\mathbf{U}|^{\frac{1}{2}(v_1+v_2) - \frac{1}{2}(q+1)} \text{etr}\left(-\frac{1}{2}\boldsymbol{\Sigma}^{-1}\mathbf{U}\right) \text{etr}\left(-\frac{1}{2}\boldsymbol{\Sigma}_1^{-\frac{1}{2}}\mathbf{U}\boldsymbol{\Sigma}_1^{-\frac{1}{2}}\mathbf{U}_0\right) d\mathbf{U}. \tag{4.61}$$



#### 4. GENERALISED BIMATRIX VARIATE BETA TYPE II DISTRIBUTIONS

##### 4.3. The generalised bimatrix variate beta type II distributions

---

Substituting (4.61) in (4.60) gives

$$\begin{aligned}
f(\mathbf{U}_0) &= C \Gamma_q \left( \frac{1}{2} v_3 \right) 2^{\frac{1}{2} q v_3} |\mathbf{U}_0|^{\frac{1}{2} v_2 - \frac{1}{2} (q+1)} |\boldsymbol{\Sigma}_1|^{\frac{1}{2} v_3} \\
&\quad \times \int_{\mathbf{U} > \mathbf{0}} |\mathbf{U}|^{\frac{1}{2} (v_1 + v_2) - \frac{1}{2} (q+1)} \text{etr} \left( -\frac{1}{2} \boldsymbol{\Sigma}^{-1} \mathbf{U} \right) \text{etr} \left( -\frac{1}{2} \boldsymbol{\Sigma}_1^{-\frac{1}{2}} \mathbf{U} \boldsymbol{\Sigma}_1^{-\frac{1}{2}} \mathbf{U}_0 \right) d\mathbf{U} \\
&= C \Gamma_q \left( \frac{1}{2} v_3 \right) 2^{\frac{1}{2} q v_3} |\mathbf{U}_0|^{\frac{1}{2} v_2 - \frac{1}{2} (q+1)} |\boldsymbol{\Sigma}_1|^{\frac{1}{2} v_3} \\
&\quad \times \int_{\mathbf{U} > \mathbf{0}} |\mathbf{U}|^{\frac{1}{2} (v_1 + v_2) - \frac{1}{2} (q+1)} \text{etr} \left( -\frac{1}{2} \boldsymbol{\Sigma}^{-1} \mathbf{U} \right) \text{etr} \left( -\frac{1}{2} \boldsymbol{\Sigma}_1^{-\frac{1}{2}} \mathbf{U}_0 \boldsymbol{\Sigma}_1^{-\frac{1}{2}} \mathbf{U} \right) d\mathbf{U} \\
&= C \Gamma_q \left( \frac{1}{2} v_3 \right) 2^{\frac{1}{2} q v_3} |\mathbf{U}_0|^{\frac{1}{2} v_2 - \frac{1}{2} (q+1)} |\boldsymbol{\Sigma}_1|^{\frac{1}{2} v_3} \\
&\quad \times \int_{\mathbf{U} > \mathbf{0}} |\mathbf{U}|^{\frac{1}{2} (v_1 + v_2) - \frac{1}{2} (q+1)} \text{etr} \left( -\frac{1}{2} \left( \boldsymbol{\Sigma}^{-1} + \boldsymbol{\Sigma}_1^{-\frac{1}{2}} \mathbf{U}_0 \boldsymbol{\Sigma}_1^{-\frac{1}{2}} \right) \mathbf{U} \right) d\mathbf{U}.
\end{aligned} \tag{4.62}$$

Integrating (4.62) with respect to  $\mathbf{U}$  using (C.54) and substituting  $C$  (4.49) gives the desired result

$$\begin{aligned}
f(\mathbf{U}_0) &= \frac{1}{2^{\frac{1}{2} q (v_1 + v_2 + v_3)} \prod_{i=1}^3 \Gamma_q \left( \frac{1}{2} v_i \right) |\boldsymbol{\Sigma}|^{\frac{1}{2} v_1} |\boldsymbol{\Sigma}_1|^{\frac{1}{2} (v_2 + v_3)}} \Gamma_q \left( \frac{1}{2} v_3 \right) 2^{\frac{1}{2} q v_3} |\mathbf{U}_0|^{\frac{1}{2} v_2 - \frac{1}{2} (q+1)} |\boldsymbol{\Sigma}_1|^{\frac{1}{2} v_3} \\
&\quad \times \Gamma_q \left( \frac{1}{2} (v_1 + v_2) \right) \left| \frac{1}{2} \left( \boldsymbol{\Sigma}^{-1} + \boldsymbol{\Sigma}_1^{-\frac{1}{2}} \mathbf{U}_0 \boldsymbol{\Sigma}_1^{-\frac{1}{2}} \right) \right|^{-\frac{1}{2} (v_1 + v_2)} \\
&= \frac{\Gamma_q \left( \frac{1}{2} (v_1 + v_2) \right)}{\Gamma_q \left( \frac{1}{2} v_1 \right) \Gamma_q \left( \frac{1}{2} v_2 \right) |\boldsymbol{\Sigma}|^{\frac{1}{2} v_1} |\boldsymbol{\Sigma}_1|^{\frac{1}{2} v_2}} |\mathbf{U}_0|^{\frac{1}{2} v_2 - \frac{1}{2} (q+1)} \left| \boldsymbol{\Sigma}^{-1} + \boldsymbol{\Sigma}_1^{-\frac{1}{2}} \mathbf{U}_0 \boldsymbol{\Sigma}_1^{-\frac{1}{2}} \right|^{-\frac{1}{2} (v_1 + v_2)}.
\end{aligned}$$

(b) From (4.51) follows that

$$\begin{aligned}
f(\mathbf{U}_1) &= \int_{\mathbf{U}_0 > \mathbf{0}} \int_{\mathbf{U} > \mathbf{0}} C |\mathbf{U}_0|^{\frac{1}{2} v_2 - \frac{1}{2} (q+1)} |\mathbf{U}_1|^{\frac{1}{2} v_3 - \frac{1}{2} (q+1)} |\mathbf{I}_q + \mathbf{U}_0|^{\frac{1}{2} v_3} |\mathbf{U}|^{\frac{1}{2} (v_1 + v_2 + v_3) - \frac{1}{2} (q+1)} \\
&\quad \times \text{etr} \left( -\frac{1}{2} \boldsymbol{\Sigma}^{-1} \mathbf{U} \right) \text{etr} \left( -\frac{1}{2} \boldsymbol{\Sigma}_1^{-1} \mathbf{U}^{\frac{1}{2}} \mathbf{U}_0 \mathbf{U}^{\frac{1}{2}} \right) \\
&\quad \times \text{etr} \left( -\frac{1}{2} \boldsymbol{\Sigma}_1^{-1} \left( \mathbf{U}^{\frac{1}{2}} (\mathbf{I}_q + \mathbf{U}_0) \mathbf{U}^{\frac{1}{2}} \right)^{\frac{1}{2}} \mathbf{U}_1 \left( \mathbf{U}^{\frac{1}{2}} (\mathbf{I}_q + \mathbf{U}_0) \mathbf{U}^{\frac{1}{2}} \right)^{\frac{1}{2}} \right) d\mathbf{U} d\mathbf{U}_0
\end{aligned}$$

4. GENERALISED BIMATRIX VARIATE BETA TYPE II DISTRIBUTIONS  
4.3. The generalised bimatrix variate beta type II distributions

---

$$\begin{aligned}
&= C |\mathbf{U}_1|^{\frac{1}{2}v_3 - \frac{1}{2}(q+1)} \int_{\mathbf{U}_0 > \mathbf{0}} |\mathbf{U}_0|^{\frac{1}{2}v_2 - \frac{1}{2}(q+1)} |\mathbf{I}_q + \mathbf{U}_0|^{\frac{1}{2}v_3} \\
&\quad \times \int_{\mathbf{U} > \mathbf{0}} |\mathbf{U}|^{\frac{1}{2}(v_1+v_2+v_3) - \frac{1}{2}(q+1)} \text{etr}\left(-\frac{1}{2}\boldsymbol{\Sigma}^{-1}\mathbf{U}\right) \text{etr}\left(-\frac{1}{2}\boldsymbol{\Sigma}_1^{-1}\mathbf{U}^{\frac{1}{2}}\mathbf{U}_0\mathbf{U}^{\frac{1}{2}}\right) \\
&\quad \times \text{etr}\left(-\frac{1}{2}\boldsymbol{\Sigma}_1^{-1}\left(\mathbf{U}^{\frac{1}{2}}(\mathbf{I}_q + \mathbf{U}_0)\mathbf{U}^{\frac{1}{2}}\right)^{\frac{1}{2}} \mathbf{U}_1 \left(\mathbf{U}^{\frac{1}{2}}(\mathbf{I}_q + \mathbf{U}_0)\mathbf{U}^{\frac{1}{2}}\right)^{\frac{1}{2}}\right) d\mathbf{U}d\mathbf{U}_0 \\
&= C |\mathbf{U}_1|^{\frac{1}{2}v_3 - \frac{1}{2}(q+1)} \int_{\mathbf{U}_0 > \mathbf{0}} |\mathbf{U}_0|^{\frac{1}{2}v_2 - \frac{1}{2}(q+1)} |\mathbf{I}_q + \mathbf{U}_0|^{\frac{1}{2}v_3} g_7(\boldsymbol{\Sigma}_1^{-1}) d\mathbf{U}_0, \tag{4.63}
\end{aligned}$$

where

$$\begin{aligned}
g_7(\boldsymbol{\Sigma}_1^{-1}) &= \int_{\mathbf{U} > \mathbf{0}} |\mathbf{U}|^{\frac{1}{2}(v_1+v_2+v_3) - \frac{1}{2}(q+1)} \text{etr}\left(-\frac{1}{2}\boldsymbol{\Sigma}^{-1}\mathbf{U}\right) \text{etr}\left(-\frac{1}{2}\boldsymbol{\Sigma}_1^{-1}\mathbf{U}^{\frac{1}{2}}\mathbf{U}_0\mathbf{U}^{\frac{1}{2}}\right) \\
&\quad \times \text{etr}\left(-\frac{1}{2}\boldsymbol{\Sigma}_1^{-1}\left(\mathbf{U}^{\frac{1}{2}}(\mathbf{I}_q + \mathbf{U}_0)\mathbf{U}^{\frac{1}{2}}\right)^{\frac{1}{2}} \mathbf{U}_1 \left(\mathbf{U}^{\frac{1}{2}}(\mathbf{I}_q + \mathbf{U}_0)\mathbf{U}^{\frac{1}{2}}\right)^{\frac{1}{2}}\right) d\mathbf{U}.
\end{aligned}$$

Expanding  $\text{etr}\left(-\frac{1}{2}\boldsymbol{\Sigma}_1^{-1}\mathbf{U}^{\frac{1}{2}}\mathbf{U}_0\mathbf{U}^{\frac{1}{2}}\right)$  and  $\text{etr}\left(-\frac{1}{2}\boldsymbol{\Sigma}_1^{-1}\left(\mathbf{U}^{\frac{1}{2}}(\mathbf{I}_q + \mathbf{U}_0)\mathbf{U}^{\frac{1}{2}}\right)^{\frac{1}{2}} \mathbf{U}_1 \left(\mathbf{U}^{\frac{1}{2}}(\mathbf{I}_q + \mathbf{U}_0)\mathbf{U}^{\frac{1}{2}}\right)^{\frac{1}{2}}\right)$  in terms of the zonal polynomials using (C.50) and applying (C.46) it follows that for any  $\mathbf{H} \in O(q)$ ,  $g_7(\boldsymbol{\Sigma}_1^{-1}) = g_7(\mathbf{H}\boldsymbol{\Sigma}_1^{-1}\mathbf{H}')$  with

$$\begin{aligned}
&g_7(\mathbf{H}\boldsymbol{\Sigma}_1^{-1}\mathbf{H}') \\
&= \int_{\mathbf{U} > \mathbf{0}} |\mathbf{U}|^{\frac{1}{2}(v_1+v_2+v_3) - \frac{1}{2}(q+1)} \text{etr}\left(-\frac{1}{2}\boldsymbol{\Sigma}^{-1}\mathbf{U}\right) \int_{O(q)} \text{etr}\left(-\frac{1}{2}\mathbf{H}\boldsymbol{\Sigma}_1^{-1}\mathbf{H}'\mathbf{U}^{\frac{1}{2}}\mathbf{U}_0\mathbf{U}^{\frac{1}{2}}\right) \\
&\quad \times \text{etr}\left(-\frac{1}{2}\mathbf{H}\boldsymbol{\Sigma}_1^{-1}\mathbf{H}'\left(\mathbf{U}^{\frac{1}{2}}(\mathbf{I}_q + \mathbf{U}_0)\mathbf{U}^{\frac{1}{2}}\right)^{\frac{1}{2}} \mathbf{U}_1 \left(\mathbf{U}^{\frac{1}{2}}(\mathbf{I}_q + \mathbf{U}_0)\mathbf{U}^{\frac{1}{2}}\right)^{\frac{1}{2}}\right) d\mathbf{H}d\mathbf{U} \\
&= \int_{\mathbf{U} > \mathbf{0}} |\mathbf{U}|^{\frac{1}{2}(v_1+v_2+v_3) - \frac{1}{2}(q+1)} \text{etr}\left(-\frac{1}{2}\boldsymbol{\Sigma}^{-1}\mathbf{U}\right) \\
&\quad \times \sum_s \sum_{\zeta} \sum_t \sum_{\tau} \frac{1}{t!} \frac{1}{s!} \int_{O(q)} C_{\zeta} \left(-\frac{1}{2}\mathbf{H}\boldsymbol{\Sigma}_1^{-1}\mathbf{H}'\mathbf{U}^{\frac{1}{2}}\mathbf{U}_0\mathbf{U}^{\frac{1}{2}}\right) \\
&\quad \times C_{\tau} \left(-\frac{1}{2}\mathbf{H}\boldsymbol{\Sigma}_1^{-1}\mathbf{H}'\left(\mathbf{U}^{\frac{1}{2}}(\mathbf{I}_q + \mathbf{U}_0)\mathbf{U}^{\frac{1}{2}}\right)^{\frac{1}{2}} \mathbf{U}_1 \left(\mathbf{U}^{\frac{1}{2}}(\mathbf{I}_q + \mathbf{U}_0)\mathbf{U}^{\frac{1}{2}}\right)^{\frac{1}{2}}\right) d\mathbf{H}d\mathbf{U} \\
&= \int_{\mathbf{U} > \mathbf{0}} |\mathbf{U}|^{\frac{1}{2}(v_1+v_2+v_3) - \frac{1}{2}(q+1)} \text{etr}\left(-\frac{1}{2}\boldsymbol{\Sigma}^{-1}\mathbf{U}\right) \\
&\quad \times \sum_s \sum_{\zeta} \sum_t \sum_{\tau} \frac{1}{t!} \frac{1}{s!} \int_{O(q)} C_{\zeta} \left(-\frac{1}{2}\mathbf{H}\boldsymbol{\Sigma}_1^{-1}\mathbf{H}'\mathbf{U}^{\frac{1}{2}}\mathbf{U}_0\mathbf{U}^{\frac{1}{2}}\right) \\
&\quad \times C_{\tau} \left(-\frac{1}{2}\mathbf{H}\boldsymbol{\Sigma}_1^{-1}\mathbf{H}'\mathbf{U}_1^{\frac{1}{2}}\mathbf{U}^{\frac{1}{2}}(\mathbf{I}_q + \mathbf{U}_0)\mathbf{U}^{\frac{1}{2}}\mathbf{U}_1^{\frac{1}{2}}\right) d\mathbf{H}d\mathbf{U},
\end{aligned}$$

#### 4. GENERALISED BIMATRIX VARIATE BETA TYPE II DISTRIBUTIONS

##### 4.3. The generalised bimatrix variate beta type II distributions

---

and

$$g_7(\boldsymbol{\Sigma}_1^{-1}) = \int_{\mathbf{U} > \mathbf{0}} |\mathbf{U}|^{\frac{1}{2}(v_1+v_2+v_3)-\frac{1}{2}(q+1)} \text{etr}\left(-\frac{1}{2}\boldsymbol{\Sigma}^{-1}\mathbf{U}\right) \text{etr}\left(-\frac{1}{2}\boldsymbol{\Sigma}_1^{-1}\mathbf{U}^{\frac{1}{2}}\mathbf{U}_0\mathbf{U}^{\frac{1}{2}}\right) \quad (4.64)$$

$$\times \text{etr}\left(-\frac{1}{2}\boldsymbol{\Sigma}_1^{-1}\mathbf{U}_1^{\frac{1}{2}}\mathbf{U}^{\frac{1}{2}}(\mathbf{I}_q + \mathbf{U}_0)\mathbf{U}^{\frac{1}{2}}\mathbf{U}_1^{\frac{1}{2}}\right) d\mathbf{U}.$$

Substituting (4.64) in (4.63) gives

$$\begin{aligned} f(\mathbf{U}_1) &= C |\mathbf{U}_1|^{\frac{1}{2}v_3-\frac{1}{2}(q+1)} \int_{\mathbf{U}_0 > \mathbf{0}} |\mathbf{U}_0|^{\frac{1}{2}v_2-\frac{1}{2}(q+1)} |\mathbf{I}_q + \mathbf{U}_0|^{\frac{1}{2}v_3} \\ &\quad \times \int_{\mathbf{U} > \mathbf{0}} |\mathbf{U}|^{\frac{1}{2}(v_1+v_2+v_3)-\frac{1}{2}(q+1)} \text{etr}\left(-\frac{1}{2}\boldsymbol{\Sigma}^{-1}\mathbf{U}\right) \text{etr}\left(-\frac{1}{2}\boldsymbol{\Sigma}_1^{-1}\mathbf{U}^{\frac{1}{2}}\mathbf{U}_0\mathbf{U}^{\frac{1}{2}}\right) \\ &\quad \times \text{etr}\left(-\frac{1}{2}\boldsymbol{\Sigma}_1^{-1}\mathbf{U}_1^{\frac{1}{2}}\mathbf{U}^{\frac{1}{2}}(\mathbf{I}_q + \mathbf{U}_0)\mathbf{U}^{\frac{1}{2}}\mathbf{U}_1^{\frac{1}{2}}\right) d\mathbf{U}d\mathbf{U}_0 \\ &= C |\mathbf{U}_1|^{\frac{1}{2}v_3-\frac{1}{2}(q+1)} \int_{\mathbf{U}_0 > \mathbf{0}} |\mathbf{U}_0|^{\frac{1}{2}v_2-\frac{1}{2}(q+1)} |\mathbf{I}_q + \mathbf{U}_0|^{\frac{1}{2}v_3} \\ &\quad \times \int_{\mathbf{U} > \mathbf{0}} |\mathbf{U}|^{\frac{1}{2}(v_1+v_2+v_3)-\frac{1}{2}(q+1)} \text{etr}\left(-\frac{1}{2}\boldsymbol{\Sigma}^{-1}\mathbf{U}\right) \text{etr}\left(-\frac{1}{2}\boldsymbol{\Sigma}_1^{-1}\mathbf{U}^{\frac{1}{2}}\mathbf{U}_0\mathbf{U}^{\frac{1}{2}}\right) \\ &\quad \times \text{etr}\left(-\frac{1}{2}\boldsymbol{\Sigma}_1^{-1}\mathbf{U}_1^{\frac{1}{2}}\mathbf{U}\mathbf{U}_1^{\frac{1}{2}}\right) \text{etr}\left(-\frac{1}{2}\boldsymbol{\Sigma}_1^{-1}\mathbf{U}_1^{\frac{1}{2}}\mathbf{U}^{\frac{1}{2}}\mathbf{U}_0\mathbf{U}^{\frac{1}{2}}\mathbf{U}_1^{\frac{1}{2}}\right) d\mathbf{U}d\mathbf{U}_0 \\ &= C |\mathbf{U}_1|^{\frac{1}{2}v_3-\frac{1}{2}(q+1)} \int_{\mathbf{U}_0 > \mathbf{0}} |\mathbf{U}_0|^{\frac{1}{2}v_2-\frac{1}{2}(q+1)} |\mathbf{I}_q + \mathbf{U}_0|^{\frac{1}{2}v_3} \\ &\quad \times \int_{\mathbf{U} > \mathbf{0}} |\mathbf{U}|^{\frac{1}{2}(v_1+v_2+v_3)-\frac{1}{2}(q+1)} \text{etr}\left(-\frac{1}{2}\boldsymbol{\Sigma}^{-1}\mathbf{U}\right) \text{etr}\left(-\frac{1}{2}\mathbf{U}_1^{\frac{1}{2}}\boldsymbol{\Sigma}_1^{-1}\mathbf{U}_1^{\frac{1}{2}}\mathbf{U}\right) \\ &\quad \times \text{etr}\left(-\frac{1}{2}\mathbf{U}^{\frac{1}{2}}\left(\boldsymbol{\Sigma}_1^{-1} + \mathbf{U}_1^{\frac{1}{2}}\boldsymbol{\Sigma}_1^{-1}\mathbf{U}_1^{\frac{1}{2}}\right)\mathbf{U}^{\frac{1}{2}}\mathbf{U}_0\right) d\mathbf{U}d\mathbf{U}_0 \\ &= C |\mathbf{U}_1|^{\frac{1}{2}v_3-\frac{1}{2}(q+1)} \int_{\mathbf{U}_0 > \mathbf{0}} |\mathbf{U}_0|^{\frac{1}{2}v_2-\frac{1}{2}(q+1)} |\mathbf{I}_q + \mathbf{U}_0|^{\frac{1}{2}v_3} g_8(\mathbf{U}_0) d\mathbf{U}_0, \quad (4.65) \end{aligned}$$

where

$$g_8(\mathbf{U}_0) = \int_{\mathbf{U} > \mathbf{0}} |\mathbf{U}|^{\frac{1}{2}(v_1+v_2+v_3)-\frac{1}{2}(q+1)} \text{etr}\left(-\frac{1}{2}\boldsymbol{\Sigma}^{-1}\mathbf{U}\right) \text{etr}\left(-\frac{1}{2}\mathbf{U}_1^{\frac{1}{2}}\boldsymbol{\Sigma}_1^{-1}\mathbf{U}_1^{\frac{1}{2}}\mathbf{U}\right)$$

$$\times \text{etr}\left(-\frac{1}{2}\mathbf{U}^{\frac{1}{2}}\left(\boldsymbol{\Sigma}_1^{-1} + \mathbf{U}_1^{\frac{1}{2}}\boldsymbol{\Sigma}_1^{-1}\mathbf{U}_1^{\frac{1}{2}}\right)\mathbf{U}^{\frac{1}{2}}\mathbf{U}_0\right) d\mathbf{U}.$$

Expanding  $\text{etr}\left(-\frac{1}{2}\mathbf{U}^{\frac{1}{2}}\left(\boldsymbol{\Sigma}_1^{-1} + \mathbf{U}_1^{\frac{1}{2}}\boldsymbol{\Sigma}_1^{-1}\mathbf{U}_1^{\frac{1}{2}}\right)\mathbf{U}^{\frac{1}{2}}\mathbf{U}_0\right)$  in terms of the zonal polynomial using (C.50) and applying (C.44) it follows that for any  $\mathbf{H} \in O(q)$ ,  $g_8(\mathbf{U}_0) = g_8(\mathbf{H}\mathbf{U}_0\mathbf{H}')$  with

#### 4. GENERALISED BIMATRIX VARIATE BETA TYPE II DISTRIBUTIONS

##### 4.3. The generalised bimatrix variate beta type II distributions

$$\begin{aligned}
 & g_8(\mathbf{H}\mathbf{U}_0\mathbf{H}') \\
 &= \int_{\mathbf{U}>\mathbf{0}} |\mathbf{U}|^{\frac{1}{2}(v_1+v_2+v_3)-\frac{1}{2}(q+1)} \text{etr}\left(-\frac{1}{2}\boldsymbol{\Sigma}^{-1}\mathbf{U}\right) \text{etr}\left(-\frac{1}{2}\mathbf{U}_1^{\frac{1}{2}}\boldsymbol{\Sigma}_1^{-1}\mathbf{U}_1^{\frac{1}{2}}\mathbf{U}\right) \\
 &\quad \times \int_{O(q)} \text{etr}\left(-\frac{1}{2}\mathbf{U}^{\frac{1}{2}}\left(\boldsymbol{\Sigma}_1^{-1} + \mathbf{U}_1^{\frac{1}{2}}\boldsymbol{\Sigma}_1^{-1}\mathbf{U}_1^{\frac{1}{2}}\right)\mathbf{U}^{\frac{1}{2}}\mathbf{H}\mathbf{U}_0\mathbf{H}'\right) d\mathbf{H}d\mathbf{U} \\
 &= \int_{\mathbf{U}>\mathbf{0}} |\mathbf{U}|^{\frac{1}{2}(v_1+v_2+v_3)-\frac{1}{2}(q+1)} \text{etr}\left(-\frac{1}{2}\boldsymbol{\Sigma}^{-1}\mathbf{U}\right) \text{etr}\left(-\frac{1}{2}\mathbf{U}_1^{\frac{1}{2}}\boldsymbol{\Sigma}_1^{-1}\mathbf{U}_1^{\frac{1}{2}}\mathbf{U}\right) \\
 &\quad \times \sum_t \sum_{\tau} \frac{1}{t!} \int_{O(q)} C_{\tau}\left(-\frac{1}{2}\mathbf{U}^{\frac{1}{2}}\left(\boldsymbol{\Sigma}_1^{-1} + \mathbf{U}_1^{\frac{1}{2}}\boldsymbol{\Sigma}_1^{-1}\mathbf{U}_1^{\frac{1}{2}}\right)\mathbf{U}^{\frac{1}{2}}\mathbf{H}\mathbf{U}_0\mathbf{H}'\right) d\mathbf{H}d\mathbf{U} \\
 &= \int_{\mathbf{U}>\mathbf{0}} |\mathbf{U}|^{\frac{1}{2}(v_1+v_2+v_3)-\frac{1}{2}(q+1)} \text{etr}\left(-\frac{1}{2}\boldsymbol{\Sigma}^{-1}\mathbf{U}\right) \text{etr}\left(-\frac{1}{2}\mathbf{U}_1^{\frac{1}{2}}\boldsymbol{\Sigma}_1^{-1}\mathbf{U}_1^{\frac{1}{2}}\mathbf{U}\right) \\
 &\quad \times \sum_t \sum_{\tau} \frac{1}{t!} \int_{O(q)} C_{\tau}\left(-\frac{1}{2}\left(\boldsymbol{\Sigma}_1^{-1} + \mathbf{U}_1^{\frac{1}{2}}\boldsymbol{\Sigma}_1^{-1}\mathbf{U}_1^{\frac{1}{2}}\right)^{\frac{1}{2}}\mathbf{U}\left(\boldsymbol{\Sigma}_1^{-1} + \mathbf{U}_1^{\frac{1}{2}}\boldsymbol{\Sigma}_1^{-1}\mathbf{U}_1^{\frac{1}{2}}\right)^{\frac{1}{2}}\mathbf{H}\mathbf{U}_0\mathbf{H}'\right) d\mathbf{H}d\mathbf{U},
 \end{aligned}$$

and

$$\begin{aligned}
 g_8(\mathbf{U}_0) &= \int_{\mathbf{U}>\mathbf{0}} |\mathbf{U}|^{\frac{1}{2}(v_1+v_2+v_3)-\frac{1}{2}(q+1)} \text{etr}\left(-\frac{1}{2}\boldsymbol{\Sigma}^{-1}\mathbf{U}\right) \text{etr}\left(-\frac{1}{2}\mathbf{U}_1^{\frac{1}{2}}\boldsymbol{\Sigma}_1^{-1}\mathbf{U}_1^{\frac{1}{2}}\mathbf{U}\right) \\
 &\quad \times \text{etr}\left(-\frac{1}{2}\left(\boldsymbol{\Sigma}_1^{-1} + \mathbf{U}_1^{\frac{1}{2}}\boldsymbol{\Sigma}_1^{-1}\mathbf{U}_1^{\frac{1}{2}}\right)^{\frac{1}{2}}\mathbf{U}\left(\boldsymbol{\Sigma}_1^{-1} + \mathbf{U}_1^{\frac{1}{2}}\boldsymbol{\Sigma}_1^{-1}\mathbf{U}_1^{\frac{1}{2}}\right)^{\frac{1}{2}}\mathbf{U}_0\right) d\mathbf{U}.
 \end{aligned} \tag{4.66}$$

Substituting (4.66) in (4.65) and applying (C.56) gives

$$\begin{aligned}
 & f(\mathbf{U}_1) \\
 &= C |\mathbf{U}_1|^{\frac{1}{2}v_3-\frac{1}{2}(q+1)} \int_{\mathbf{U}_0>\mathbf{0}} |\mathbf{U}_0|^{\frac{1}{2}v_2-\frac{1}{2}(q+1)} |\mathbf{I}_q + \mathbf{U}_0|^{\frac{1}{2}v_3} \\
 &\quad \times \int_{\mathbf{U}>\mathbf{0}} |\mathbf{U}|^{\frac{1}{2}(v_1+v_2+v_3)-\frac{1}{2}(q+1)} \text{etr}\left(-\frac{1}{2}\boldsymbol{\Sigma}^{-1}\mathbf{U}\right) \text{etr}\left(-\frac{1}{2}\mathbf{U}_1^{\frac{1}{2}}\boldsymbol{\Sigma}_1^{-1}\mathbf{U}_1^{\frac{1}{2}}\mathbf{U}\right) \\
 &\quad \times \text{etr}\left(-\frac{1}{2}\left(\boldsymbol{\Sigma}_1^{-1} + \mathbf{U}_1^{\frac{1}{2}}\boldsymbol{\Sigma}_1^{-1}\mathbf{U}_1^{\frac{1}{2}}\right)^{\frac{1}{2}}\mathbf{U}\left(\boldsymbol{\Sigma}_1^{-1} + \mathbf{U}_1^{\frac{1}{2}}\boldsymbol{\Sigma}_1^{-1}\mathbf{U}_1^{\frac{1}{2}}\right)^{\frac{1}{2}}\mathbf{U}_0\right) d\mathbf{U}d\mathbf{U}_0 \\
 &= C |\mathbf{U}_1|^{\frac{1}{2}v_3-\frac{1}{2}(q+1)} \int_{\mathbf{U}>\mathbf{0}} |\mathbf{U}|^{\frac{1}{2}(v_1+v_2+v_3)-\frac{1}{2}(q+1)} \text{etr}\left(-\frac{1}{2}\boldsymbol{\Sigma}^{-1}\mathbf{U}\right) \text{etr}\left(-\frac{1}{2}\mathbf{U}_1^{\frac{1}{2}}\boldsymbol{\Sigma}_1^{-1}\mathbf{U}_1^{\frac{1}{2}}\mathbf{U}\right) \\
 &\quad \times \int_{\mathbf{U}_0>\mathbf{0}} |\mathbf{U}_0|^{\frac{1}{2}v_2-\frac{1}{2}(q+1)} |\mathbf{I}_q + \mathbf{U}_0|^{\frac{1}{2}v_3} \\
 &\quad \times \text{etr}\left(-\frac{1}{2}\left(\boldsymbol{\Sigma}_1^{-1} + \mathbf{U}_1^{\frac{1}{2}}\boldsymbol{\Sigma}_1^{-1}\mathbf{U}_1^{\frac{1}{2}}\right)^{\frac{1}{2}}\mathbf{U}\left(\boldsymbol{\Sigma}_1^{-1} + \mathbf{U}_1^{\frac{1}{2}}\boldsymbol{\Sigma}_1^{-1}\mathbf{U}_1^{\frac{1}{2}}\right)^{\frac{1}{2}}\mathbf{U}_0\right) d\mathbf{U}_0d\mathbf{U}
 \end{aligned}$$

#### 4. GENERALISED BIMATRIX VARIATE BETA TYPE II DISTRIBUTIONS

##### 4.3. The generalised bimatrix variate beta type II distributions

$$\begin{aligned}
 &= C |\mathbf{U}_1|^{\frac{1}{2}v_3 - \frac{1}{2}(q+1)} \int_{\mathbf{U} > \mathbf{0}} |\mathbf{U}|^{\frac{1}{2}(v_1+v_2+v_3) - \frac{1}{2}(q+1)} \text{etr}\left(-\frac{1}{2}\boldsymbol{\Sigma}^{-1}\mathbf{U}\right) \text{etr}\left(-\frac{1}{2}\mathbf{U}_1^{\frac{1}{2}}\boldsymbol{\Sigma}_1^{-1}\mathbf{U}_1^{\frac{1}{2}}\mathbf{U}\right) \\
 &\quad \times \Gamma_q\left(\frac{1}{2}v_2\right) \\
 &\quad \times \Psi\left(\frac{v_2}{2}, \frac{v_2+v_3}{2} + \frac{q+1}{2}, \frac{1}{2}\left(\boldsymbol{\Sigma}_1^{-1} + \mathbf{U}_1^{\frac{1}{2}}\boldsymbol{\Sigma}_1^{-1}\mathbf{U}_1^{\frac{1}{2}}\right)^{\frac{1}{2}}\mathbf{U}\left(\boldsymbol{\Sigma}_1^{-1} + \mathbf{U}_1^{\frac{1}{2}}\boldsymbol{\Sigma}_1^{-1}\mathbf{U}_1^{\frac{1}{2}}\right)^{\frac{1}{2}}\right) d\mathbf{U} \\
 &= C \Gamma_q\left(\frac{1}{2}v_2\right) |\mathbf{U}_1|^{\frac{1}{2}v_3 - \frac{1}{2}(q+1)} \int_{\mathbf{U} > \mathbf{0}} |\mathbf{U}|^{\frac{1}{2}(v_1+v_2+v_3) - \frac{1}{2}(q+1)} \\
 &\quad \times \text{etr}\left(-\frac{1}{2}\left(\boldsymbol{\Sigma}^{-1} + \mathbf{U}_1^{\frac{1}{2}}\boldsymbol{\Sigma}_1^{-1}\mathbf{U}_1^{\frac{1}{2}}\right)\mathbf{U}\right) \\
 &\quad \times \Psi\left(\frac{v_2}{2}, \frac{v_2+v_3}{2} + \frac{q+1}{2}, \frac{1}{2}\left(\boldsymbol{\Sigma}_1^{-1} + \mathbf{U}_1^{\frac{1}{2}}\boldsymbol{\Sigma}_1^{-1}\mathbf{U}_1^{\frac{1}{2}}\right)^{\frac{1}{2}}\mathbf{U}\left(\boldsymbol{\Sigma}_1^{-1} + \mathbf{U}_1^{\frac{1}{2}}\boldsymbol{\Sigma}_1^{-1}\mathbf{U}_1^{\frac{1}{2}}\right)^{\frac{1}{2}}\right) d\mathbf{U}. \tag{4.67}
 \end{aligned}$$

Integrating (4.67) with respect to  $\mathbf{U}$  using (C.58) and substituting  $C$  (4.49) gives

$$\begin{aligned}
 &f(\mathbf{U}_1) \\
 &= \frac{\Gamma_q\left(\frac{1}{2}v_2\right) \Gamma_q\left(\frac{1}{2}(v_1+v_2+v_3)\right) \Gamma_q\left(\frac{1}{2}v_1\right)}{2^{\frac{1}{2}q(v_1+v_2+v_3)} \prod_{i=1}^3 \Gamma_q\left(\frac{v_i}{2}\right) \Gamma_q\left(\frac{1}{2}(v_1+v_2)\right) |\boldsymbol{\Sigma}|^{\frac{1}{2}v_1} |\boldsymbol{\Sigma}_1|^{\frac{1}{2}(v_2+v_3)}} |\mathbf{U}_1|^{\frac{1}{2}v_3 - \frac{1}{2}(q+1)} \\
 &\quad \times \left|\frac{1}{2}\left(\boldsymbol{\Sigma}_1^{-1} + \mathbf{U}_1^{\frac{1}{2}}\boldsymbol{\Sigma}_1^{-1}\mathbf{U}_1^{\frac{1}{2}}\right)\right|^{-\frac{1}{2}(v_1+v_2+v_3)} \\
 &\quad \times {}_2F_1\left(\frac{1}{2}v_1, \frac{1}{2}(v_1+v_2+v_3); \frac{1}{2}(v_1+v_2)\right) \\
 &\quad \quad ; \mathbf{I}_q - \left(\boldsymbol{\Sigma}_1^{-1} + \mathbf{U}_1^{\frac{1}{2}}\boldsymbol{\Sigma}_1^{-1}\mathbf{U}_1^{\frac{1}{2}}\right)^{-\frac{1}{2}} \left(\boldsymbol{\Sigma}^{-1} + \mathbf{U}_1^{\frac{1}{2}}\boldsymbol{\Sigma}_1^{-1}\mathbf{U}_1^{\frac{1}{2}}\right) \left(\boldsymbol{\Sigma}_1^{-1} + \mathbf{U}_1^{\frac{1}{2}}\boldsymbol{\Sigma}_1^{-1}\mathbf{U}_1^{\frac{1}{2}}\right)^{-\frac{1}{2}} \\
 &= \frac{\Gamma_q\left(\frac{1}{2}(v_1+v_2+v_3)\right)}{\Gamma_q\left(\frac{1}{2}v_3\right) \Gamma_q\left(\frac{1}{2}(v_1+v_2)\right) |\boldsymbol{\Sigma}|^{\frac{1}{2}v_1} |\boldsymbol{\Sigma}_1|^{\frac{1}{2}(v_2+v_3)}} |\mathbf{U}_1|^{\frac{1}{2}v_3 - \frac{1}{2}(q+1)} \left|\boldsymbol{\Sigma}_1^{-1} + \mathbf{U}_1^{\frac{1}{2}}\boldsymbol{\Sigma}_1^{-1}\mathbf{U}_1^{\frac{1}{2}}\right|^{-\frac{1}{2}(v_1+v_2+v_3)} \\
 &\quad \times {}_2F_1\left(\frac{1}{2}v_1, \frac{1}{2}(v_1+v_2+v_3); \frac{1}{2}(v_1+v_2)\right) \\
 &\quad \quad ; \mathbf{I}_q - \left(\boldsymbol{\Sigma}_1^{-1} + \mathbf{U}_1^{\frac{1}{2}}\boldsymbol{\Sigma}_1^{-1}\mathbf{U}_1^{\frac{1}{2}}\right)^{-\frac{1}{2}} \left(\boldsymbol{\Sigma}^{-1} + \mathbf{U}_1^{\frac{1}{2}}\boldsymbol{\Sigma}_1^{-1}\mathbf{U}_1^{\frac{1}{2}}\right) \left(\boldsymbol{\Sigma}_1^{-1} + \mathbf{U}_1^{\frac{1}{2}}\boldsymbol{\Sigma}_1^{-1}\mathbf{U}_1^{\frac{1}{2}}\right)^{-\frac{1}{2}}.
 \end{aligned}$$

## 4. GENERALISED BIMATRIX VARIATE BETA TYPE II DISTRIBUTIONS

### 4.3. The generalised bimatrix variate beta type II distributions

Rewriting the hypergeometric function of matrix argument,  ${}_2F_1(\cdot)$ , using (C.55) gives

$$\begin{aligned}
 f(\mathbf{U}_1) &= \frac{\Gamma_q\left(\frac{1}{2}(v_1 + v_2 + v_3)\right)}{\Gamma_q\left(\frac{1}{2}v_3\right)\Gamma_q\left(\frac{1}{2}(v_1 + v_2)\right)} |\boldsymbol{\Sigma}|^{\frac{1}{2}v_1} |\boldsymbol{\Sigma}_1|^{\frac{1}{2}(v_2+v_3)} |\mathbf{U}_1|^{\frac{1}{2}v_3 - \frac{1}{2}(q+1)} \left| \boldsymbol{\Sigma}_1^{-1} + \mathbf{U}_1^{\frac{1}{2}} \boldsymbol{\Sigma}_1^{-1} \mathbf{U}_1^{\frac{1}{2}} \right|^{-\frac{1}{2}(v_1+v_2+v_3)} \\
 &\times \left| \left( \boldsymbol{\Sigma}_1^{-1} + \mathbf{U}_1^{\frac{1}{2}} \boldsymbol{\Sigma}_1^{-1} \mathbf{U}_1^{\frac{1}{2}} \right)^{-\frac{1}{2}} \left( \boldsymbol{\Sigma}^{-1} + \mathbf{U}_1^{\frac{1}{2}} \boldsymbol{\Sigma}_1^{-1} \mathbf{U}_1^{\frac{1}{2}} \right) \left( \boldsymbol{\Sigma}_1^{-1} + \mathbf{U}_1^{\frac{1}{2}} \boldsymbol{\Sigma}_1^{-1} \mathbf{U}_1^{\frac{1}{2}} \right)^{-\frac{1}{2}} \right|^{-\frac{1}{2}(v_1+v_2+v_3)} \\
 &\times {}_2F_1\left(\frac{1}{2}v_2, \frac{1}{2}(v_1 + v_2 + v_3); \frac{1}{2}(v_1 + v_2); \mathbf{I}_q - \left( \boldsymbol{\Sigma}_1^{-1} + \mathbf{U}_1^{\frac{1}{2}} \boldsymbol{\Sigma}_1^{-1} \mathbf{U}_1^{\frac{1}{2}} \right)^{\frac{1}{2}} \left( \boldsymbol{\Sigma}^{-1} + \mathbf{U}_1^{\frac{1}{2}} \boldsymbol{\Sigma}_1^{-1} \mathbf{U}_1^{\frac{1}{2}} \right)^{-1} \left( \boldsymbol{\Sigma}_1^{-1} + \mathbf{U}_1^{\frac{1}{2}} \boldsymbol{\Sigma}_1^{-1} \mathbf{U}_1^{\frac{1}{2}} \right)^{\frac{1}{2}}\right) \\
 &= \frac{\Gamma_q\left(\frac{1}{2}(v_1 + v_2 + v_3)\right)}{\Gamma_q\left(\frac{1}{2}v_3\right)\Gamma_q\left(\frac{1}{2}(v_1 + v_2)\right)} |\boldsymbol{\Sigma}|^{\frac{1}{2}v_1} |\boldsymbol{\Sigma}_1|^{\frac{1}{2}(v_2+v_3)} |\mathbf{U}_1|^{\frac{1}{2}v_3 - \frac{1}{2}(q+1)} \left| \boldsymbol{\Sigma}^{-1} + \mathbf{U}_1^{\frac{1}{2}} \boldsymbol{\Sigma}_1^{-1} \mathbf{U}_1^{\frac{1}{2}} \right|^{-\frac{1}{2}(v_1+v_2+v_3)} \\
 &\times {}_2F_1\left(\frac{1}{2}v_2, \frac{1}{2}(v_1 + v_2 + v_3); \frac{1}{2}(v_1 + v_2); \mathbf{I}_q - \left( \boldsymbol{\Sigma}_1^{-1} + \mathbf{U}_1^{\frac{1}{2}} \boldsymbol{\Sigma}_1^{-1} \mathbf{U}_1^{\frac{1}{2}} \right)^{\frac{1}{2}} \left( \boldsymbol{\Sigma}^{-1} + \mathbf{U}_1^{\frac{1}{2}} \boldsymbol{\Sigma}_1^{-1} \mathbf{U}_1^{\frac{1}{2}} \right)^{-1} \left( \boldsymbol{\Sigma}_1^{-1} + \mathbf{U}_1^{\frac{1}{2}} \boldsymbol{\Sigma}_1^{-1} \mathbf{U}_1^{\frac{1}{2}} \right)^{\frac{1}{2}}\right).
 \end{aligned}$$

■

**Remark 4.5** Substituting  $\boldsymbol{\Sigma} = \mathbf{I}_q$  and  $\boldsymbol{\Sigma}_1 = \lambda \mathbf{I}_q$  in (4.57) simplifies to (4.14),

$$\begin{aligned}
 f(\mathbf{U}_0) &= \frac{\Gamma_q\left(\frac{1}{2}(v_1 + v_2)\right)}{\Gamma_q\left(\frac{v_1}{2}\right)\Gamma_q\left(\frac{v_2}{2}\right)} |\mathbf{I}_q|^{\frac{1}{2}v_1} |\lambda \mathbf{I}_q|^{\frac{1}{2}v_2} |\mathbf{U}_0|^{\frac{1}{2}v_2 - \frac{1}{2}(q+1)} \left| \mathbf{I}_q + \lambda^{-1} \mathbf{U}_0 \right|^{-\frac{1}{2}(v_1+v_2)} \\
 &= \frac{\Gamma_q\left(\frac{1}{2}(v_1 + v_2)\right)}{\Gamma_q\left(\frac{v_1}{2}\right)\Gamma_q\left(\frac{v_2}{2}\right)} \lambda^{\frac{1}{2}qv_2} |\mathbf{U}_0|^{\frac{1}{2}v_2 - \frac{1}{2}(q+1)} \left| \lambda^{-1} (\lambda \mathbf{I}_q + \mathbf{U}_0) \right|^{-\frac{1}{2}(v_1+v_2)} \\
 &= \frac{\Gamma_q\left(\frac{1}{2}(v_1 + v_2)\right) \lambda^{\frac{1}{2}qv_1}}{\Gamma_q\left(\frac{v_1}{2}\right)\Gamma_q\left(\frac{v_2}{2}\right)} |\mathbf{U}_0|^{\frac{1}{2}v_2 - \frac{1}{2}(q+1)} \left| \lambda \mathbf{I}_q + \mathbf{U}_0 \right|^{-\frac{1}{2}(v_1+v_2)}, \\
 &\qquad \qquad \qquad \mathbf{U}_0 > \mathbf{0}.
 \end{aligned}$$

**Remark 4.6** Substituting  $\boldsymbol{\Sigma} = \mathbf{I}_q$  and  $\boldsymbol{\Sigma}_1 = \lambda \mathbf{I}_q$  in (4.58) simplifies to (4.15),

$$\begin{aligned}
 f(\mathbf{U}_1) &= \frac{\Gamma_q\left(\frac{1}{2}(v_1 + v_2 + v_3)\right)}{\Gamma_q\left(\frac{1}{2}v_3\right)\Gamma_q\left(\frac{1}{2}(v_1 + v_2)\right)} |\mathbf{I}_q|^{\frac{1}{2}v_1} |\lambda \mathbf{I}_q|^{\frac{1}{2}(v_2+v_3)} |\mathbf{U}_1|^{\frac{1}{2}v_3 - \frac{1}{2}(q+1)} \left| \mathbf{I}_q + \lambda^{-1} \mathbf{U}_1 \right|^{-\frac{1}{2}(v_1+v_2+v_3)} \\
 &\times {}_2F_1\left(\frac{v_2}{2}, \frac{v_1+v_2+v_3}{2}; \frac{v_1+v_2}{2}; \mathbf{I}_q - \left( \lambda^{-1} \mathbf{I}_q + \lambda^{-1} \mathbf{U}_1 \right)^{\frac{1}{2}} \left( \mathbf{I}_q + \lambda^{-1} \mathbf{U}_1 \right)^{-1} \left( \lambda^{-1} \mathbf{I}_q + \lambda^{-1} \mathbf{U}_1 \right)^{\frac{1}{2}}\right) \\
 &= \frac{\Gamma_q\left(\frac{1}{2}(v_1 + v_2 + v_3)\right)}{\Gamma_q\left(\frac{1}{2}v_3\right)\Gamma_q\left(\frac{1}{2}(v_1 + v_2)\right)} \lambda^{\frac{1}{2}q(v_2+v_3)} |\mathbf{U}_1|^{\frac{1}{2}v_3 - \frac{1}{2}(q+1)} \left| \lambda^{-1} (\lambda \mathbf{I}_q + \mathbf{U}_1) \right|^{-\frac{1}{2}(v_1+v_2+v_3)} \\
 &\times {}_2F_1\left(\frac{1}{2}v_2, \frac{1}{2}(v_1 + v_2 + v_3); \frac{1}{2}(v_1 + v_2); \mathbf{I}_q - \left( \mathbf{I}_q + \mathbf{U}_1 \right)^{\frac{1}{2}} (\lambda \mathbf{I}_q + \mathbf{U}_1)^{-1} \left( \mathbf{I}_q + \mathbf{U}_1 \right)^{\frac{1}{2}}\right)
 \end{aligned}$$

## 4. GENERALISED BIMATRIX VARIATE BETA TYPE II DISTRIBUTIONS

### 4.3. The generalised bimatrix variate beta type II distributions

$$\begin{aligned}
 &= \frac{\Gamma_q\left(\frac{1}{2}(v_1 + v_2 + v_3)\right)}{\Gamma_q\left(\frac{1}{2}v_3\right)\Gamma_q\left(\frac{1}{2}(v_1 + v_2)\right)} \lambda^{\frac{1}{2}qv_1} |\mathbf{U}_1|^{\frac{1}{2}v_3 - \frac{1}{2}(q+1)} |\lambda\mathbf{I}_q + \mathbf{U}_1|^{-\frac{1}{2}(v_1+v_2+v_3)} \\
 &\quad \times {}_2F_1\left(\frac{1}{2}v_2, \frac{1}{2}(v_1 + v_2 + v_3); \frac{1}{2}(v_1 + v_2); \mathbf{I}_q - (\mathbf{I}_q + \mathbf{U}_1)^{\frac{1}{2}} (\lambda\mathbf{I}_q + \mathbf{U}_1)^{-1} (\mathbf{I}_q + \mathbf{U}_1)^{\frac{1}{2}}\right) \\
 &\quad \mathbf{U}_1 > \mathbf{0}, \left\| \mathbf{I}_q - (\mathbf{I}_q + \mathbf{U}_1)^{\frac{1}{2}} (\lambda\mathbf{I}_q + \mathbf{U}_1)^{-1} (\mathbf{I}_q + \mathbf{U}_1)^{\frac{1}{2}} \right\| < 1.
 \end{aligned}$$

#### 4.3.2.3 Product moment of the determinants

The  $(h_1, h_2)^{th}$  product moment,  $E\left(|\mathbf{U}_0|^{h_1} |\mathbf{U}_1|^{h_2}\right)$ , where  $(\mathbf{U}_0, \mathbf{U}_1)$  is distributed as (4.47) is derived in Theorem 4.7 with the  $h^{th}$  moments of  $|\mathbf{U}_0|$  and  $|\mathbf{U}_1|$  given in Lemma 4.3.2.

**Theorem 4.7** *Suppose that  $\mathbf{X} \sim W_q(v_1, \Sigma)$  is independent of  $\mathbf{W}_0 \sim W_q(v_2, \Sigma_1)$  and  $\mathbf{W}_1 \sim W_q(v_3, \Sigma_1)$ . If the joint pdf of (4.2) is given by (4.47), then,*

$$\begin{aligned}
 &E\left(|\mathbf{U}_0|^{h_1} |\mathbf{U}_1|^{h_2}\right) \\
 &= \frac{\Gamma_q\left(\frac{1}{2}(v_1 + v_2) - h_2\right) \Gamma_q\left(\frac{1}{2}v_3 + h_2\right) \Gamma_q\left(\frac{1}{2}v_1 - h_1\right) \Gamma_q\left(\frac{1}{2}v_2 + h_1\right)}{\prod_{i=1}^3 \Gamma_q\left(\frac{1}{2}v_i\right) \Gamma_q\left(\frac{1}{2}(v_1 + v_2)\right)} \quad (4.68) \\
 &\quad \times |\Sigma|^{-\frac{1}{2}v_1} |\Sigma_1|^{\frac{1}{2}v_1} \\
 &\quad \times {}_2F_1\left(\frac{1}{2}v_1 - h_1, \frac{1}{2}(v_1 + v_2) - h_2; \frac{1}{2}(v_1 + v_2); \mathbf{I}_q - \Sigma_1^{\frac{1}{2}} \Sigma^{-1} \Sigma_1^{\frac{1}{2}}\right)
 \end{aligned}$$

where  $\left\| \mathbf{I}_q - \Sigma_1^{\frac{1}{2}} \Sigma^{-1} \Sigma_1^{\frac{1}{2}} \right\| < 1$ ,  $\text{Re}\left(\frac{1}{2}(v_1 + v_2) - h_2\right) > \frac{1}{2}(q - 1)$ ,  $\text{Re}\left(\frac{1}{2}v_3 + h_2\right) > \frac{1}{2}(q - 1)$ ,  $\text{Re}\left(\frac{1}{2}v_1 - h_1\right) > \frac{1}{2}(q - 1)$ ,  $\text{Re}\left(\frac{1}{2}v_2 + h_1\right) > \frac{1}{2}(q - 1)$ .

**Proof.** From (4.50)

$$\begin{aligned}
 &E\left(|\mathbf{U}_0|^{h_1} |\mathbf{U}_1|^{h_2}\right) \\
 &= \int_{\mathbf{U} > \mathbf{0}} \int_{\mathbf{U}_0 > \mathbf{0}} \int_{\mathbf{U}_1 > \mathbf{0}} C |\mathbf{U}|^{\frac{1}{2}(v_1+v_2+v_3) - \frac{1}{2}(q+1)} |\mathbf{U}_0|^{\frac{1}{2}v_2+h_1 - \frac{1}{2}(q+1)} |\mathbf{U}_1|^{\frac{1}{2}v_3+h_2 - \frac{1}{2}(q+1)} |\mathbf{I}_q + \mathbf{U}_0|^{\frac{1}{2}v_3} \\
 &\quad \times \text{etr}\left(-\frac{1}{2}\Sigma^{-1}\mathbf{U}\right) \text{etr}\left(-\frac{1}{2}\Sigma_1^{-1}\mathbf{U}^{\frac{1}{2}}\mathbf{U}_0\mathbf{U}^{\frac{1}{2}}\right) \\
 &\quad \times \text{etr}\left(-\frac{1}{2}\Sigma_1^{-1}\left(\mathbf{U}^{\frac{1}{2}}(\mathbf{I}_q + \mathbf{U}_0)\mathbf{U}^{\frac{1}{2}}\right)^{\frac{1}{2}} \mathbf{U}_1 \left(\mathbf{U}^{\frac{1}{2}}(\mathbf{I}_q + \mathbf{U}_0)\mathbf{U}^{\frac{1}{2}}\right)^{\frac{1}{2}}\right) d\mathbf{U}_1 d\mathbf{U}_0 d\mathbf{U}
 \end{aligned}$$

#### 4. GENERALISED BIMATRIX VARIATE BETA TYPE II DISTRIBUTIONS

##### 4.3. The generalised bimatrix variate beta type II distributions

$$\begin{aligned}
&= C \int_{\mathbf{U} > \mathbf{0}} |\mathbf{U}|^{\frac{1}{2}(v_1+v_2+v_3)-\frac{1}{2}(q+1)} \text{etr}\left(-\frac{1}{2}\boldsymbol{\Sigma}^{-1}\mathbf{U}\right) \\
&\quad \times \int_{\mathbf{U}_0 > \mathbf{0}} |\mathbf{U}_0|^{\frac{1}{2}v_2+h_1-\frac{1}{2}(q+1)} |\mathbf{I}_q + \mathbf{U}_0|^{\frac{1}{2}v_3} \text{etr}\left(-\frac{1}{2}\boldsymbol{\Sigma}_1^{-1}\mathbf{U}_0^{\frac{1}{2}}\mathbf{U}_0\mathbf{U}_0^{\frac{1}{2}}\right) \\
&\quad \times \int_{\mathbf{U}_1 > \mathbf{0}} |\mathbf{U}_1|^{\frac{1}{2}v_3+h_2-\frac{1}{2}(q+1)} \\
&\quad \times \text{etr}\left(-\frac{1}{2}\left(\mathbf{U}_0^{\frac{1}{2}}(\mathbf{I}_q + \mathbf{U}_0)\mathbf{U}_0^{\frac{1}{2}}\right)^{\frac{1}{2}}\boldsymbol{\Sigma}_1^{-1}\left(\mathbf{U}_0^{\frac{1}{2}}(\mathbf{I}_q + \mathbf{U}_0)\mathbf{U}_0^{\frac{1}{2}}\right)^{\frac{1}{2}}\mathbf{U}_1\right) d\mathbf{U}_1 d\mathbf{U}_0 d\mathbf{U}.
\end{aligned}$$

Solving the integral with respect to  $\mathbf{U}_1$  using (C.54) gives

$$\begin{aligned}
&E\left(|\mathbf{U}_0|^{h_1} |\mathbf{U}_1|^{h_2}\right) \\
&= C \int_{\mathbf{U} > \mathbf{0}} |\mathbf{U}|^{\frac{1}{2}(v_1+v_2+v_3)-\frac{1}{2}(q+1)} \text{etr}\left(-\frac{1}{2}\boldsymbol{\Sigma}^{-1}\mathbf{U}\right) \\
&\quad \times \int_{\mathbf{U}_0 > \mathbf{0}} |\mathbf{U}_0|^{\frac{1}{2}v_2+h_1-\frac{1}{2}(q+1)} |\mathbf{I}_q + \mathbf{U}_0|^{\frac{1}{2}v_3} \text{etr}\left(-\frac{1}{2}\boldsymbol{\Sigma}_1^{-1}\mathbf{U}_0^{\frac{1}{2}}\mathbf{U}_0\mathbf{U}_0^{\frac{1}{2}}\right) \\
&\quad \times \Gamma_q\left(\frac{1}{2}v_3 + h_2\right) \left| \frac{1}{2}\left(\mathbf{U}_0^{\frac{1}{2}}(\mathbf{I}_q + \mathbf{U}_0)\mathbf{U}_0^{\frac{1}{2}}\right)^{\frac{1}{2}}\boldsymbol{\Sigma}_1^{-1}\left(\mathbf{U}_0^{\frac{1}{2}}(\mathbf{I}_q + \mathbf{U}_0)\mathbf{U}_0^{\frac{1}{2}}\right)^{\frac{1}{2}} \right|^{-\left(\frac{1}{2}v_3+h_2\right)} d\mathbf{U}_0 d\mathbf{U} \\
&= C\Gamma_q\left(\frac{1}{2}v_3 + h_2\right) 2^{\frac{1}{2}qv_3+qh_2} |\boldsymbol{\Sigma}_1|^{\frac{1}{2}v_3+h_2} \int_{\mathbf{U} > \mathbf{0}} |\mathbf{U}|^{\frac{1}{2}(v_1+v_2)-h_2-\frac{1}{2}(q+1)} \text{etr}\left(-\frac{1}{2}\boldsymbol{\Sigma}^{-1}\mathbf{U}\right) \\
&\quad \times \int_{\mathbf{U}_0 > \mathbf{0}} |\mathbf{U}_0|^{\frac{1}{2}v_2+h_1-\frac{1}{2}(q+1)} |\mathbf{I}_q + \mathbf{U}_0|^{-h_2} \text{etr}\left(-\frac{1}{2}\boldsymbol{\Sigma}_1^{-1}\mathbf{U}_0^{\frac{1}{2}}\mathbf{U}_0\mathbf{U}_0^{\frac{1}{2}}\right) d\mathbf{U}_0 d\mathbf{U} \\
&= C\Gamma_q\left(\frac{1}{2}v_3 + h_2\right) 2^{\frac{1}{2}qv_3+qh_2} |\boldsymbol{\Sigma}_1|^{\frac{1}{2}v_3+h_2} \int_{\mathbf{U}_0 > \mathbf{0}} |\mathbf{U}_0|^{\frac{1}{2}v_2+h_1-\frac{1}{2}(q+1)} |\mathbf{I}_q + \mathbf{U}_0|^{-h_2} \\
&\quad \times \int_{\mathbf{U} > \mathbf{0}} |\mathbf{U}|^{\frac{1}{2}(v_1+v_2)-h_2-\frac{1}{2}(q+1)} \text{etr}\left(-\frac{1}{2}\boldsymbol{\Sigma}^{-1}\mathbf{U}\right) \text{etr}\left(-\frac{1}{2}\boldsymbol{\Sigma}_1^{-1}\mathbf{U}_0^{\frac{1}{2}}\mathbf{U}_0\mathbf{U}_0^{\frac{1}{2}}\right) d\mathbf{U} d\mathbf{U}_0 \\
&= C\Gamma_q\left(\frac{1}{2}v_3 + h_2\right) 2^{\frac{1}{2}qv_3+qh_2} |\boldsymbol{\Sigma}_1|^{\frac{1}{2}v_3+h_2} \\
&\quad \times \int_{\mathbf{U}_0 > \mathbf{0}} |\mathbf{U}_0|^{\frac{1}{2}v_2+h_1-\frac{1}{2}(q+1)} |\mathbf{I}_q + \mathbf{U}_0|^{-h_2} g_9(\mathbf{U}_0) d\mathbf{U}_0, \tag{4.69}
\end{aligned}$$

where

$$g_9(\mathbf{U}_0) = \int_{\mathbf{U} > \mathbf{0}} |\mathbf{U}|^{\frac{1}{2}(v_1+v_2)-h_2-\frac{1}{2}(q+1)} \text{etr}\left(-\frac{1}{2}\boldsymbol{\Sigma}^{-1}\mathbf{U}\right) \text{etr}\left(-\frac{1}{2}\boldsymbol{\Sigma}_1^{-1}\mathbf{U}_0^{\frac{1}{2}}\mathbf{U}_0\mathbf{U}_0^{\frac{1}{2}}\right) d\mathbf{U}.$$

Expanding  $\text{etr}\left(-\frac{1}{2}\boldsymbol{\Sigma}_1^{-1}\mathbf{U}_0^{\frac{1}{2}}\mathbf{U}_0\mathbf{U}_0^{\frac{1}{2}}\right)$  in terms of the zonal polynomial using (C.50) and applying (C.44) it follows that for any  $\mathbf{H} \in O(q)$ ,  $g_9(\mathbf{U}_0) = g_9(\mathbf{H}\mathbf{U}_0\mathbf{H}')$  with



#### 4. GENERALISED BIMATRIX VARIATE BETA TYPE II DISTRIBUTIONS

##### 4.3. The generalised bimatrix variate beta type II distributions

$$\begin{aligned}
 g_9(\mathbf{H}\mathbf{U}_0\mathbf{H}') &= \int_{\mathbf{U}>\mathbf{0}} |\mathbf{U}|^{\frac{1}{2}(v_1+v_2)-h_2-\frac{1}{2}(q+1)} \text{etr}\left(-\frac{1}{2}\boldsymbol{\Sigma}^{-1}\mathbf{U}\right) \int_{O(q)} \text{etr}\left(-\frac{1}{2}\boldsymbol{\Sigma}_1^{-1}\mathbf{U}^{\frac{1}{2}}\mathbf{H}\mathbf{U}_0\mathbf{H}'\mathbf{U}^{\frac{1}{2}}\right) d\mathbf{H}d\mathbf{U} \\
 &= \int_{\mathbf{U}>\mathbf{0}} |\mathbf{U}|^{\frac{1}{2}(v_1+v_2)-h_2-\frac{1}{2}(q+1)} \text{etr}\left(-\frac{1}{2}\boldsymbol{\Sigma}^{-1}\mathbf{U}\right) \sum_t \sum_{\tau} \frac{1}{t!} \int_{O(q)} C_{\tau}\left(-\frac{1}{2}\mathbf{U}^{\frac{1}{2}}\boldsymbol{\Sigma}_1^{-1}\mathbf{U}^{\frac{1}{2}}\mathbf{H}\mathbf{U}_0\mathbf{H}'\right) d\mathbf{H}d\mathbf{U} \\
 &= \int_{\mathbf{U}>\mathbf{0}} |\mathbf{U}|^{\frac{1}{2}(v_1+v_2)-h_2-\frac{1}{2}(q+1)} \text{etr}\left(-\frac{1}{2}\boldsymbol{\Sigma}^{-1}\mathbf{U}\right) \sum_t \sum_{\tau} \frac{1}{t!} \int_{O(q)} C_{\tau}\left(-\frac{1}{2}\boldsymbol{\Sigma}_1^{-\frac{1}{2}}\mathbf{U}\boldsymbol{\Sigma}_1^{-\frac{1}{2}}\mathbf{H}\mathbf{U}_0\mathbf{H}'\right) d\mathbf{H}d\mathbf{U},
 \end{aligned}$$

and

$$g_9(\mathbf{U}_0) = \int_{\mathbf{U}>\mathbf{0}} |\mathbf{U}|^{\frac{1}{2}(v_1+v_2)-h_2-\frac{1}{2}(q+1)} \text{etr}\left(-\frac{1}{2}\boldsymbol{\Sigma}^{-1}\mathbf{U}\right) \text{etr}\left(-\frac{1}{2}\boldsymbol{\Sigma}_1^{-\frac{1}{2}}\mathbf{U}\boldsymbol{\Sigma}_1^{-\frac{1}{2}}\mathbf{U}_0\right) d\mathbf{U}. \quad (4.70)$$

Substituting (4.70) in (4.69) gives

$$\begin{aligned}
 E\left(|\mathbf{U}_0|^{h_1} |\mathbf{U}_1|^{h_2}\right) &= C\Gamma_q\left(\frac{1}{2}v_3 + h_2\right) 2^{\frac{1}{2}qv_3+qh_2} |\boldsymbol{\Sigma}_1|^{\frac{1}{2}v_3+h_2} \int_{\mathbf{U}_0>\mathbf{0}} |\mathbf{U}_0|^{\frac{1}{2}v_2+h_1-\frac{1}{2}(q+1)} |\mathbf{I}_q + \mathbf{U}_0|^{-h_2} \\
 &\quad \times \int_{\mathbf{U}>\mathbf{0}} |\mathbf{U}|^{\frac{1}{2}(v_1+v_2)-h_2-\frac{1}{2}(q+1)} \text{etr}\left(-\frac{1}{2}\boldsymbol{\Sigma}^{-1}\mathbf{U}\right) \text{etr}\left(-\frac{1}{2}\boldsymbol{\Sigma}_1^{-\frac{1}{2}}\mathbf{U}\boldsymbol{\Sigma}_1^{-\frac{1}{2}}\mathbf{U}_0\right) d\mathbf{U}d\mathbf{U}_0 \\
 &= C\Gamma_q\left(\frac{1}{2}v_3 + h_2\right) 2^{\frac{1}{2}qv_3+qh_2} |\boldsymbol{\Sigma}_1|^{\frac{1}{2}v_3+h_2} \int_{\mathbf{U}_0>\mathbf{0}} |\mathbf{U}_0|^{\frac{1}{2}v_2+h_1-\frac{1}{2}(q+1)} |\mathbf{I}_q + \mathbf{U}_0|^{-h_2} \quad (4.71) \\
 &\quad \times \int_{\mathbf{U}>\mathbf{0}} |\mathbf{U}|^{\frac{1}{2}(v_1+v_2)-h_2-\frac{1}{2}(q+1)} \text{etr}\left(-\frac{1}{2}\left(\boldsymbol{\Sigma}^{-1} + \boldsymbol{\Sigma}_1^{-\frac{1}{2}}\mathbf{U}_0\boldsymbol{\Sigma}_1^{-\frac{1}{2}}\right)\mathbf{U}\right) d\mathbf{U}d\mathbf{U}_0.
 \end{aligned}$$

Integrating (4.71) with respect to  $\mathbf{U}$  using (C.54) gives

$$\begin{aligned}
 E\left(|\mathbf{U}_0|^{h_1} |\mathbf{U}_1|^{h_2}\right) &= C\Gamma_q\left(\frac{1}{2}v_3 + h_2\right) 2^{\frac{1}{2}qv_3+qh_2} |\boldsymbol{\Sigma}_1|^{\frac{1}{2}v_3+h_2} \int_{\mathbf{U}_0>\mathbf{0}} |\mathbf{U}_0|^{\frac{1}{2}v_2+h_1-\frac{1}{2}(q+1)} |\mathbf{I}_q + \mathbf{U}_0|^{-h_2} \\
 &\quad \times \Gamma_q\left(\frac{1}{2}(v_1 + v_2) - h_2\right) \left|\frac{1}{2}\left(\boldsymbol{\Sigma}^{-1} + \boldsymbol{\Sigma}_1^{-\frac{1}{2}}\mathbf{U}_0\boldsymbol{\Sigma}_1^{-\frac{1}{2}}\right)\right|^{-\left(\frac{1}{2}(v_1+v_2)-h_2\right)} d\mathbf{U}_0 \\
 &= C\Gamma_q\left(\frac{1}{2}v_3 + h_2\right) \Gamma_q\left(\frac{1}{2}(v_1 + v_2) - h_2\right) 2^{\frac{1}{2}q(v_1+v_2+v_3)} |\boldsymbol{\Sigma}_1|^{\frac{1}{2}v_3+h_2} \\
 &\quad \times \int_{\mathbf{U}_0>\mathbf{0}} |\mathbf{U}_0|^{\frac{1}{2}v_2+h_1-\frac{1}{2}(q+1)} |\mathbf{I}_q + \mathbf{U}_0|^{-h_2} \\
 &\quad \times \left|\boldsymbol{\Sigma}^{-\frac{1}{2}}\left(\mathbf{I}_q + \boldsymbol{\Sigma}^{\frac{1}{2}}\boldsymbol{\Sigma}_1^{-\frac{1}{2}}\mathbf{U}_0\boldsymbol{\Sigma}_1^{-\frac{1}{2}}\boldsymbol{\Sigma}^{\frac{1}{2}}\right)\boldsymbol{\Sigma}^{-\frac{1}{2}}\right|^{-\left(\frac{1}{2}(v_1+v_2)-h_2\right)} d\mathbf{U}_0
 \end{aligned}$$

## 4. GENERALISED BIMATRIX VARIATE BETA TYPE II DISTRIBUTIONS

## 4.3. The generalised bimatrix variate beta type II distributions

$$\begin{aligned}
 &= C \Gamma_q \left( \frac{1}{2} v_3 + h_2 \right) \Gamma_q \left( \frac{1}{2} (v_1 + v_2) - h_2 \right) 2^{\frac{1}{2} q (v_1 + v_2 + v_3)} |\Sigma|^{\frac{1}{2} (v_1 + v_2) - h_2} |\Sigma_1|^{\frac{1}{2} v_3 + h_2} \\
 &\quad \times \int_{\mathbf{U}_0 > \mathbf{0}} |\mathbf{U}_0|^{\frac{1}{2} v_2 + h_1 - \frac{1}{2} (q+1)} |\mathbf{I}_q + \mathbf{U}_0|^{-h_2} \left| \mathbf{I}_q + \Sigma_1^{-\frac{1}{2}} \Sigma \Sigma_1^{-\frac{1}{2}} \mathbf{U}_0 \right|^{-\left( \frac{1}{2} (v_1 + v_2) - h_2 \right)} d\mathbf{U}_0.
 \end{aligned} \tag{4.72}$$

Integrating (4.72) with respect to  $\mathbf{U}_0$  using (C.53), substituting  $C$  (4.49) and rewriting the multivariate beta functions using (C.36) gives

$$\begin{aligned}
 &E \left( |\mathbf{U}_0|^{h_1} |\mathbf{U}_1|^{h_2} \right) \\
 &= \frac{\Gamma_q \left( \frac{1}{2} v_3 + h_2 \right) \Gamma_q \left( \frac{1}{2} (v_1 + v_2) - h_2 \right) 2^{\frac{1}{2} q (v_1 + v_2 + v_3)} |\Sigma|^{\frac{1}{2} (v_1 + v_2) - h_2} |\Sigma_1|^{\frac{1}{2} v_3 + h_2}}{2^{\frac{1}{2} q (v_1 + v_2 + v_3)} \prod_{i=1}^3 \Gamma_q \left( \frac{1}{2} v_i \right) |\Sigma|^{\frac{1}{2} v_1} |\Sigma_1|^{\frac{1}{2} (v_2 + v_3)}}} \\
 &\quad \times \beta_q \left( \frac{1}{2} v_2 + h_1, \frac{1}{2} v_1 - h_1 \right) \left| \Sigma_1^{-\frac{1}{2}} \Sigma \Sigma_1^{-\frac{1}{2}} \right|^{-\left( \frac{1}{2} (v_1 + v_2) - h_2 \right)} \\
 &\quad \times {}_2F_1 \left( \frac{1}{2} v_1 - h_1, \frac{1}{2} (v_1 + v_2) - h_2; \frac{1}{2} (v_1 + v_2); \mathbf{I}_q - \Sigma_1^{\frac{1}{2}} \Sigma^{-1} \Sigma_1^{\frac{1}{2}} \right) \\
 &= \frac{\Gamma_q \left( \frac{1}{2} (v_1 + v_2) - h_2 \right) \Gamma_q \left( \frac{1}{2} v_3 + h_2 \right) \Gamma_q \left( \frac{1}{2} v_1 - h_1 \right) \Gamma_q \left( \frac{1}{2} v_2 + h_1 \right)}{\prod_{i=1}^3 \Gamma_q \left( \frac{1}{2} v_i \right) \Gamma_q \left( \frac{1}{2} (v_1 + v_2) \right)} |\Sigma|^{-\frac{1}{2} v_1} |\Sigma_1|^{\frac{1}{2} v_1} \\
 &\quad \times {}_2F_1 \left( \frac{1}{2} v_1 - h_1, \frac{1}{2} (v_1 + v_2) - h_2; \frac{1}{2} (v_1 + v_2); \mathbf{I}_q - \Sigma_1^{\frac{1}{2}} \Sigma^{-1} \Sigma_1^{\frac{1}{2}} \right).
 \end{aligned}$$

■

**Lemma 4.3.2** *The  $h^{\text{th}}$  moment of  $|\mathbf{U}_0|$  and  $|\mathbf{U}_1|$  where  $(\mathbf{U}_0, \mathbf{U}_1)$  is distributed as (4.47) can be obtained from (4.68):*

(a)

$$E \left( |\mathbf{U}_0|^h \right) = \frac{\Gamma_q \left( \frac{1}{2} v_1 - h \right) \Gamma_q \left( \frac{1}{2} v_2 + h \right) \left| \Sigma_1^{\frac{1}{2}} \Sigma^{-1} \Sigma_1^{\frac{1}{2}} \right|^h}{\Gamma_q \left( \frac{1}{2} v_1 \right) \Gamma_q \left( \frac{1}{2} v_2 \right)}, \tag{4.73}$$

where  $\text{Re} \left( \frac{1}{2} v_1 - h \right) > \frac{1}{2} (q - 1)$ ,  $\text{Re} \left( \frac{1}{2} v_2 + h \right) > \frac{1}{2} (q - 1)$ .

(b)

$$\begin{aligned}
 E \left( |\mathbf{U}_1|^h \right) &= \frac{\Gamma_q \left( \frac{1}{2} (v_1 + v_2) - h \right) \Gamma_q \left( \frac{1}{2} v_3 + h \right)}{\Gamma_q \left( \frac{1}{2} v_3 \right) \Gamma_q \left( \frac{1}{2} (v_1 + v_2) \right)} |\Sigma|^{-\frac{1}{2} v_1} |\Sigma_1|^{\frac{1}{2} v_1} \\
 &\quad \times {}_2F_1 \left( \frac{1}{2} v_1, \frac{1}{2} (v_1 + v_2) - h; \frac{1}{2} (v_1 + v_2); \mathbf{I}_q - \Sigma_1^{\frac{1}{2}} \Sigma^{-1} \Sigma_1^{\frac{1}{2}} \right),
 \end{aligned} \tag{4.74}$$

where  $\left\| \mathbf{I}_q - \Sigma_1^{\frac{1}{2}} \Sigma^{-1} \Sigma_1^{\frac{1}{2}} \right\| < 1$ ,  $\text{Re} \left( \frac{1}{2} (v_1 + v_2) - h \right) > \frac{1}{2} (q - 1)$ ,  $\text{Re} \left( \frac{1}{2} v_3 + h \right) > \frac{1}{2} (q - 1)$ .

#### 4. GENERALISED BIMATRIX VARIATE BETA TYPE II DISTRIBUTIONS

##### 4.3. The generalised bimatrix variate beta type II distributions

**Proof.** (a) Set  $h_1 = h$  and  $h_2 = 0$  in (4.68) and using (C.51) it follows

$$\begin{aligned}
E\left(|\mathbf{U}_0|^h\right) &= \frac{\Gamma_q\left(\frac{1}{2}(v_1+v_2)\right)\Gamma_q\left(\frac{1}{2}v_3\right)\Gamma_q\left(\frac{1}{2}v_1-h\right)\Gamma_q\left(\frac{1}{2}v_2+h\right)}{\Gamma_q\left(\frac{1}{2}v_1\right)\Gamma_q\left(\frac{1}{2}v_2\right)\Gamma_q\left(\frac{1}{2}v_3\right)\Gamma_q\left(\frac{1}{2}(v_1+v_2)\right)}|\boldsymbol{\Sigma}|^{-\frac{1}{2}v_1}|\boldsymbol{\Sigma}_1|^{\frac{1}{2}v_1} \\
&\quad \times {}_2F_1\left(\frac{1}{2}v_1-h, \frac{1}{2}(v_1+v_2); \frac{1}{2}(v_1+v_2); \mathbf{I}_q - \boldsymbol{\Sigma}_1^{\frac{1}{2}}\boldsymbol{\Sigma}^{-1}\boldsymbol{\Sigma}_1^{\frac{1}{2}}\right) \\
&= \frac{\Gamma_q\left(\frac{1}{2}v_1-h\right)\Gamma_q\left(\frac{1}{2}v_2+h\right)}{\Gamma_q\left(\frac{1}{2}v_1\right)\Gamma_q\left(\frac{1}{2}v_2\right)}|\boldsymbol{\Sigma}|^{-\frac{1}{2}v_1}|\boldsymbol{\Sigma}_1|^{\frac{1}{2}v_1}{}_1F_0\left(\frac{1}{2}v_1-h; \mathbf{I}_q - \boldsymbol{\Sigma}_1^{\frac{1}{2}}\boldsymbol{\Sigma}^{-1}\boldsymbol{\Sigma}_1^{\frac{1}{2}}\right) \\
&= \frac{\Gamma_q\left(\frac{1}{2}v_1-h\right)\Gamma_q\left(\frac{1}{2}v_2+h\right)}{\Gamma_q\left(\frac{1}{2}v_1\right)\Gamma_q\left(\frac{1}{2}v_2\right)}|\boldsymbol{\Sigma}|^{-\frac{1}{2}v_1}|\boldsymbol{\Sigma}_1|^{\frac{1}{2}v_1}\left|\mathbf{I}_q - \left(\mathbf{I}_q - \boldsymbol{\Sigma}_1^{\frac{1}{2}}\boldsymbol{\Sigma}^{-1}\boldsymbol{\Sigma}_1^{\frac{1}{2}}\right)\right|^{-\left(\frac{1}{2}v_1-h\right)} \\
&= \frac{\Gamma_q\left(\frac{1}{2}v_1-h\right)\Gamma_q\left(\frac{1}{2}v_2+h\right)}{\Gamma_q\left(\frac{1}{2}v_1\right)\Gamma_q\left(\frac{1}{2}v_2\right)}\left|\boldsymbol{\Sigma}_1^{\frac{1}{2}}\boldsymbol{\Sigma}^{-1}\boldsymbol{\Sigma}_1^{\frac{1}{2}}\right|^h \\
&= \frac{\Gamma_q\left(\frac{1}{2}v_1-h\right)\Gamma_q\left(\frac{1}{2}v_2+h\right)}{\Gamma_q\left(\frac{1}{2}v_1\right)\Gamma_q\left(\frac{1}{2}v_2\right)}|\boldsymbol{\Sigma}^{-1}\boldsymbol{\Sigma}_1|^h.
\end{aligned}$$

(b) Set  $h_1 = 0$  and  $h_2 = h$  in (4.68), then

$$\begin{aligned}
E\left(|\mathbf{U}_1|^h\right) &= \frac{\Gamma_q\left(\frac{1}{2}(v_1+v_2)-h\right)\Gamma_q\left(\frac{1}{2}v_3+h\right)\Gamma_q\left(\frac{1}{2}v_1\right)\Gamma_q\left(\frac{1}{2}v_2\right)}{\Gamma_q\left(\frac{1}{2}v_1\right)\Gamma_q\left(\frac{1}{2}v_2\right)\Gamma_q\left(\frac{1}{2}v_3\right)\Gamma_q\left(\frac{1}{2}(v_1+v_2)\right)}|\boldsymbol{\Sigma}|^{-\frac{1}{2}v_1}|\boldsymbol{\Sigma}_1|^{\frac{1}{2}v_1} \\
&\quad \times {}_2F_1\left(\frac{1}{2}v_1, \frac{1}{2}(v_1+v_2)-h; \frac{1}{2}(v_1+v_2); \mathbf{I}_q - \boldsymbol{\Sigma}_1^{\frac{1}{2}}\boldsymbol{\Sigma}^{-1}\boldsymbol{\Sigma}_1^{\frac{1}{2}}\right) \\
&= \frac{\Gamma_q\left(\frac{1}{2}(v_1+v_2)-h\right)\Gamma_q\left(\frac{1}{2}v_3+h\right)}{\Gamma_q\left(\frac{1}{2}v_3\right)\Gamma_q\left(\frac{1}{2}(v_1+v_2)\right)}|\boldsymbol{\Sigma}|^{-\frac{1}{2}v_1}|\boldsymbol{\Sigma}_1|^{\frac{1}{2}v_1} \\
&\quad \times {}_2F_1\left(\frac{1}{2}v_1, \frac{1}{2}(v_1+v_2)-h; \frac{1}{2}(v_1+v_2); \mathbf{I}_q - \boldsymbol{\Sigma}_1^{\frac{1}{2}}\boldsymbol{\Sigma}^{-1}\boldsymbol{\Sigma}_1^{\frac{1}{2}}\right).
\end{aligned}$$

■

#### 4.3.2.4 Distributions of $|\mathbf{U}_0|$ , $|\mathbf{U}_1|$ and $|\mathbf{U}_0\mathbf{U}_1|$

Exact expressions for the pdfs of  $|\mathbf{U}_0|$ ,  $|\mathbf{U}_1|$  and  $|\mathbf{U}_0\mathbf{U}_1|$  are derived in Theorem 4.8. Similarly as before, the expressions of the cumulative distribution function of  $|\mathbf{U}_0|$  and  $|\mathbf{U}_1|$  are also included.

## 4. GENERALISED BIMATRIX VARIATE BETA TYPE II DISTRIBUTIONS

### 4.3. The generalised bimatrix variate beta type II distributions

---

**Theorem 4.8** *Suppose that  $\mathbf{X} \sim W_q(v_1, \Sigma)$  is independent of  $\mathbf{W}_0 \sim W_q(v_2, \Sigma_1)$  and  $\mathbf{W}_1 \sim W_q(v_3, \Sigma_1)$ . The ratios (4.2) have joint pdf (4.47) with marginal pdfs given in (4.57) and (4.58), respectively. Then,*

(a) *the pdf of  $|\mathbf{U}_0|$  is given by*

$$f(|\mathbf{U}_0|) = \frac{\pi^{\frac{q(q-1)}{2}}}{\Gamma_q\left(\frac{1}{2}v_1\right)\Gamma_q\left(\frac{1}{2}v_2\right)} |\Sigma_1^{-1}\Sigma| G_{q,q}^{q,q} \left( |\Sigma_1^{-1}\Sigma| |\mathbf{U}_0|_{b_1, \dots, b_q}^{a_1, \dots, a_q} \right), \quad (4.75)$$

$$|\mathbf{U}_0| > 0,$$

(b) *with CDF*

$$F_{|\mathbf{U}_0|}(c) = \Pr(|\mathbf{U}_0| \leq c)$$

$$= \frac{\pi^{\frac{q(q-1)}{2}}}{\Gamma_q\left(\frac{1}{2}v_1\right)\Gamma_q\left(\frac{1}{2}v_2\right)} G_{q+1,q+1}^{q,q+1} \left( |\Sigma_1^{-1}\Sigma| c_{b_1+1, \dots, b_q+1,0}^{1,a_1+1, \dots, a_q+1} \right), \quad (4.76)$$

$$c > 0,$$

where  $a_j = -\frac{1}{2}v_1 + \frac{1}{2}(j-1)$  and  $b_j = \frac{1}{2}v_2 - \frac{1}{2}(j+1)$  for  $j = 1, 2, \dots, q$ .

(c) *The pdf of  $|\mathbf{U}_1|$  is given by*

$$f(|\mathbf{U}_1|)$$

$$= \frac{\pi^{\frac{q(q-1)}{2}} |\Sigma|^{-\frac{1}{2}v_1} |\Sigma_1|^{\frac{1}{2}v_1}}{\Gamma_q\left(\frac{1}{2}v_1\right)\Gamma_q\left(\frac{1}{2}v_3\right)} \quad (4.77)$$

$$\times \sum_{t=0}^{\infty} \sum_{\tau} \frac{\Gamma_q\left(\frac{1}{2}v_1, \tau\right)}{\Gamma_q\left(\frac{1}{2}(v_1+v_2), \tau\right)} \frac{1}{t!} C_{\tau} \left( \mathbf{I}_q - \Sigma_1^{\frac{1}{2}} \Sigma^{-1} \Sigma_1^{\frac{1}{2}} \right) G_{q,q}^{q,q} \left( |\mathbf{U}_1|_{b_1, \dots, b_q}^{a_1, \dots, a_q} \right),$$

$$|\mathbf{U}_1| > 0,$$

(d) *with CDF*

$$F_{|\mathbf{U}_1|}(c) = \Pr(|\mathbf{U}_1| \leq c)$$

$$= \frac{\pi^{\frac{q(q-1)}{2}} |\Sigma|^{-\frac{1}{2}v_1} |\Sigma_1|^{\frac{1}{2}v_1}}{\Gamma_q\left(\frac{1}{2}v_1\right)\Gamma_q\left(\frac{1}{2}v_3\right)} \quad (4.78)$$

$$\sum_{t=0}^{\infty} \sum_{\tau} \frac{\Gamma_q\left(\frac{1}{2}v_1, \tau\right)}{\Gamma_q\left(\frac{1}{2}(v_1+v_2), \tau\right)} \frac{1}{t!} C_{\tau} \left( \mathbf{I}_q - \Sigma_1^{\frac{1}{2}} \Sigma^{-1} \Sigma_1^{\frac{1}{2}} \right) G_{q+1,q+1}^{q,q+1} \left( c_{b_1+1, \dots, b_q+1,0}^{1,a_1+1, \dots, a_q+1} \right),$$

$$c > 0,$$

where  $a_j = -\frac{1}{2}(v_1+v_2) - t_j + \frac{1}{2}(j-1)$  and  $b_j = \frac{1}{2}v_3 - \frac{1}{2}(j+1)$  for  $j = 1, 2, \dots, q$ .

4. GENERALISED BIMATRIX VARIATE BETA TYPE II DISTRIBUTIONS  
4.3. The generalised bimatrix variate beta type II distributions

(e) The pdf of  $|\mathbf{U}_0\mathbf{U}_1|$  is given by

$$\begin{aligned}
 f(|\mathbf{U}_0\mathbf{U}_1|) &= \frac{|\boldsymbol{\Sigma}|^{-\frac{1}{2}v_1} |\boldsymbol{\Sigma}_1|^{\frac{1}{2}v_1}}{\Gamma_q\left(\frac{1}{2}v_1\right) \Gamma_q\left(\frac{1}{2}v_2\right) \Gamma_q\left(\frac{1}{2}v_3\right)} \\
 &\times \sum_{t=0}^{\infty} \sum_{\tau} \frac{\pi^{q(q-1)}}{\Gamma_q\left(\frac{1}{2}(v_1+v_2), \tau\right) t!} C_{\tau} \left(\mathbf{I}_q - \boldsymbol{\Sigma}_1^{\frac{1}{2}} \boldsymbol{\Sigma}^{-1} \boldsymbol{\Sigma}_1^{\frac{1}{2}}\right) G_{2q,2q}^{2q,2q} \left(|\mathbf{U}_0\mathbf{U}_1| \left|_{b_1, \dots, b_{2q}}^{a_1, \dots, a_{2q}}\right.\right), \\
 &|\mathbf{U}_0\mathbf{U}_1| > 0,
 \end{aligned} \tag{4.79}$$

where

$$\begin{aligned}
 a_j &= \begin{cases} -\frac{1}{2}v_1 - t_{\frac{j+1}{2}} + \frac{1}{4}(j-1) & \text{for } j = 1, 3, \dots, 2q-1 \\ -\frac{1}{2}(v_1+v_2) - t_{\frac{j}{2}} + \frac{1}{4}(j-2) & \text{for } j = 2, 4, \dots, 2q, \end{cases} \\
 b_j &= \begin{cases} \frac{1}{2}v_3 - 1 - \frac{(j-1)}{4} & \text{for } j = 1, 3, \dots, 2q-1 \\ \frac{1}{2}v_2 - 1 - \frac{(j-2)}{4} & \text{for } j = 2, 4, \dots, 2q. \end{cases}
 \end{aligned}$$

**Proof.** (a) From (4.73),

$$E\left(|\mathbf{U}_0|^{h-1}\right) = \frac{\Gamma_q\left(\frac{1}{2}v_1 - h + 1\right) \Gamma_q\left(\frac{1}{2}v_2 + h - 1\right) |\boldsymbol{\Sigma}^{-1}\boldsymbol{\Sigma}_1|^{h-1}}{\Gamma_q\left(\frac{1}{2}v_1\right) \Gamma_q\left(\frac{1}{2}v_2\right)},$$

therefore the Mellin transform (see (B.14)) of  $f(|\boldsymbol{\Sigma}_1^{-1}\boldsymbol{\Sigma}\mathbf{U}_0|)$  is

$$\begin{aligned}
 M_f(h) &\equiv E\left(|\boldsymbol{\Sigma}_1^{-1}\boldsymbol{\Sigma}\mathbf{U}_0|^{h-1}\right) \\
 &= \frac{\Gamma_q\left(\frac{1}{2}v_1 - h + 1\right) \Gamma_q\left(\frac{1}{2}v_2 + h - 1\right)}{\Gamma_q\left(\frac{1}{2}v_1\right) \Gamma_q\left(\frac{1}{2}v_2\right)}.
 \end{aligned} \tag{4.80}$$

As in the proof of Theorem 4.4(a), Section 4.3.1.4, it follows that

$$M_f(h) = \frac{\pi^{\frac{q(q-1)}{2}} \prod_{j=1}^q \Gamma[1 - a_j - h] \prod_{j=1}^q \Gamma[b_j + h]}{\Gamma_q\left(\frac{1}{2}v_1\right) \Gamma_q\left(\frac{1}{2}v_2\right)}, \quad (\text{see (4.36)})$$

where  $a_j = -\frac{1}{2}v_1 + \frac{1}{2}(j-1)$  and  $b_j = \frac{1}{2}v_2 - \frac{1}{2}(j+1)$ ,  $j = 1, 2, \dots, q$ .

## 4. GENERALISED BIMATRIX VARIATE BETA TYPE II DISTRIBUTIONS

### 4.3. The generalised bimatrix variate beta type II distributions

The pdf of  $|\Sigma_1^{-1}\Sigma\mathbf{U}_0|$  is uniquely obtained from the inverse Mellin transform (see (B.15)) of (4.36) and the definition of the Meijer's G-function (see (B.16)) and is given by

$$\begin{aligned}
 f(|\Sigma_1^{-1}\Sigma\mathbf{U}_0|) &= \frac{1}{2\pi i} \int_{\omega-i\infty}^{\omega+i\infty} M_f(h) |\Sigma_1^{-1}\Sigma\mathbf{U}_0|^{-h} dh \\
 &= \frac{\pi^{\frac{q(q-1)}{2}}}{\Gamma_q(\frac{1}{2}v_1) \Gamma_q(\frac{1}{2}v_2)} \frac{1}{2\pi i} \int_{\omega-i\infty}^{\omega+i\infty} \prod_{j=1}^q \Gamma[1-a_j-h] \prod_{j=1}^q \Gamma[b_j+h] |\Sigma_1^{-1}\Sigma\mathbf{U}_0|^{-h} dh \\
 &= \frac{\pi^{\frac{q(q-1)}{2}}}{\Gamma_q(\frac{1}{2}v_1) \Gamma_q(\frac{1}{2}v_2)} G_{q,q}^{q,q} \left( |\Sigma_1^{-1}\Sigma\mathbf{U}_0| \middle|_{b_1, \dots, b_q}^{a_1, \dots, a_q} \right).
 \end{aligned}$$

Therefore

$$f(|\mathbf{U}_0|) = \frac{\pi^{\frac{q(q-1)}{2}}}{\Gamma_q(\frac{1}{2}v_1) \Gamma_q(\frac{1}{2}v_2)} |\Sigma_1^{-1}\Sigma| G_{q,q}^{q,q} \left( |\Sigma_1^{-1}\Sigma| |\mathbf{U}_0| \middle|_{b_1, \dots, b_q}^{a_1, \dots, a_q} \right).$$

(b) Let  $u = |\mathbf{U}_0|$ ,  $u > 0$  then from (4.75) the CDF is defined as

$$\begin{aligned}
 F_{|\mathbf{U}_0|}(c) &= \Pr(|\mathbf{U}_0| \leq c) \\
 &= \frac{\pi^{\frac{q(q-1)}{2}}}{\Gamma_q(\frac{1}{2}v_1) \Gamma_q(\frac{1}{2}v_2)} |\Sigma_1^{-1}\Sigma| \int_0^c G_{q,q}^{q,q} \left( |\Sigma_1^{-1}\Sigma| u \middle|_{b_1, \dots, b_q}^{a_1, \dots, a_q} \right) du.
 \end{aligned}$$

Applying (B.27), (B.28) and (B.25), yields the desired result:

$$\begin{aligned}
 F_{|\mathbf{U}_0|}(c) &= \frac{\pi^{\frac{q(q-1)}{2}}}{\Gamma_q(\frac{1}{2}v_1) \Gamma_q(\frac{1}{2}v_2)} |\Sigma_1^{-1}\Sigma| \int_0^c H_{q,q}^{q,q} \left( |\Sigma_1^{-1}\Sigma| u \middle|_{(b_1,1), \dots, (b_q,1)}^{(a_1,1), \dots, (a_q,1)} \right) du \\
 &= \frac{\pi^{\frac{q(q-1)}{2}}}{\Gamma_q(\frac{1}{2}v_1) \Gamma_q(\frac{1}{2}v_2)} |\Sigma_1^{-1}\Sigma| c H_{q+1,q+1}^{q,q+1} \left( |\Sigma_1^{-1}\Sigma| c \middle|_{(b_1,1), \dots, (b_q,1), (-1,1)}^{(0,1), (a_1,1), \dots, (a_q,1)} \right) \\
 &= \frac{\pi^{\frac{q(q-1)}{2}}}{\Gamma_q(\frac{1}{2}v_1) \Gamma_q(\frac{1}{2}v_2)} |\Sigma_1^{-1}\Sigma| c G_{q+1,q+1}^{q,q+1} \left( |\Sigma_1^{-1}\Sigma| c \middle|_{b_1, \dots, b_q, -1}^{0, a_1, \dots, a_q} \right) \\
 &= \frac{\pi^{\frac{q(q-1)}{2}}}{\Gamma_q(\frac{1}{2}v_1) \Gamma_q(\frac{1}{2}v_2)} G_{q+1,q+1}^{q,q+1} \left( |\Sigma_1^{-1}\Sigma| c \middle|_{b_1+1, \dots, b_q+1, 0}^{1, a_1+1, \dots, a_q+1} \right).
 \end{aligned}$$

(c) From (4.74) the Mellin transform (see (B.14)) of  $f(|\mathbf{U}_1|)$  is

$$\begin{aligned}
 M_f(h) &\equiv E \left( |\mathbf{U}_1|^{h-1} \right)
 \end{aligned}$$

#### 4. GENERALISED BIMATRIX VARIATE BETA TYPE II DISTRIBUTIONS

##### 4.3. The generalised bimatrix variate beta type II distributions

$$\begin{aligned}
 &= \frac{\Gamma_q\left(\frac{1}{2}(v_1 + v_2) - h + 1\right) \Gamma_q\left(\frac{1}{2}v_3 + h - 1\right)}{\Gamma_q\left(\frac{1}{2}v_3\right) \Gamma_q\left(\frac{1}{2}(v_1 + v_2)\right)} |\Sigma|^{-\frac{1}{2}v_1} |\Sigma_1|^{\frac{1}{2}v_1} \\
 &\quad \times {}_2F_1\left(\frac{1}{2}v_1, \frac{1}{2}(v_1 + v_2) - h + 1; \frac{1}{2}(v_1 + v_2); \mathbf{I}_q - \Sigma_1^{\frac{1}{2}} \Sigma^{-1} \Sigma_1^{\frac{1}{2}}\right).
 \end{aligned} \tag{4.81}$$

From (C.49) and (C.40) the Gauss hypergeometric function of matrix argument in (4.81) can be written as

$$\begin{aligned}
 &{}_2F_1\left(\frac{1}{2}v_1, \frac{1}{2}(v_1 + v_2) - h + 1; \frac{1}{2}(v_1 + v_2); \mathbf{I}_q - \Sigma_1^{\frac{1}{2}} \Sigma^{-1} \Sigma_1^{\frac{1}{2}}\right) \\
 &= \sum_{t=0}^{\infty} \sum_{\tau} \frac{\left(\frac{1}{2}v_1\right)_{\tau} \left(\frac{1}{2}(v_1 + v_2) - h + 1\right)_{\tau}}{\left(\frac{1}{2}(v_1 + v_2)\right)_{\tau} t!} C_{\tau}\left(\mathbf{I}_q - \Sigma_1^{\frac{1}{2}} \Sigma^{-1} \Sigma_1^{\frac{1}{2}}\right) \\
 &= \sum_{t=0}^{\infty} \sum_{\tau} \frac{\Gamma_q\left(\frac{1}{2}v_1, \tau\right) \Gamma_q\left(\frac{1}{2}(v_1 + v_2) - h + 1, \tau\right)}{\Gamma_q\left(\frac{1}{2}v_1\right)} \frac{\Gamma_q\left(\frac{1}{2}(v_1 + v_2) - h + 1, \tau\right)}{\Gamma_q\left(\frac{1}{2}(v_1 + v_2) - h + 1\right)} \frac{\Gamma_q\left(\frac{1}{2}(v_1 + v_2)\right)}{\Gamma_q\left(\frac{1}{2}(v_1 + v_2), \tau\right)} \frac{1}{t!} \\
 &\quad \times C_{\tau}\left(\mathbf{I}_q - \Sigma_1^{\frac{1}{2}} \Sigma^{-1} \Sigma_1^{\frac{1}{2}}\right).
 \end{aligned} \tag{4.82}$$

Substituting (4.82) in (4.81) gives

$$\begin{aligned}
 &M_f(h) \\
 &= \frac{\Gamma_q\left(\frac{1}{2}(v_1 + v_2) - h + 1\right) \Gamma_q\left(\frac{1}{2}v_3 + h - 1\right)}{\Gamma_q\left(\frac{1}{2}v_3\right) \Gamma_q\left(\frac{1}{2}(v_1 + v_2)\right)} |\Sigma|^{-\frac{1}{2}v_1} |\Sigma_1|^{\frac{1}{2}v_1} \\
 &\quad \times \sum_{t=0}^{\infty} \sum_{\tau} \frac{\Gamma_q\left(\frac{1}{2}v_1, \tau\right) \Gamma_q\left(\frac{1}{2}(v_1 + v_2) - h + 1, \tau\right)}{\Gamma_q\left(\frac{1}{2}v_1\right)} \frac{\Gamma_q\left(\frac{1}{2}(v_1 + v_2) - h + 1, \tau\right)}{\Gamma_q\left(\frac{1}{2}(v_1 + v_2) - h + 1\right)} \frac{\Gamma_q\left(\frac{1}{2}(v_1 + v_2)\right)}{\Gamma_q\left(\frac{1}{2}(v_1 + v_2), \tau\right)} \frac{1}{t!} C_{\tau}\left(\mathbf{I}_q - \Sigma_1^{\frac{1}{2}} \Sigma^{-1} \Sigma_1^{\frac{1}{2}}\right) \\
 &= \frac{\Gamma_q\left(\frac{1}{2}v_3 + h - 1\right)}{\Gamma_q\left(\frac{1}{2}v_1\right) \Gamma_q\left(\frac{1}{2}v_3\right)} |\Sigma|^{-\frac{1}{2}v_1} |\Sigma_1|^{\frac{1}{2}v_1} \\
 &\quad \times \sum_{t=0}^{\infty} \sum_{\tau} \frac{\Gamma_q\left(\frac{1}{2}v_1, \tau\right) \Gamma_q\left(\frac{1}{2}(v_1 + v_2) - h + 1, \tau\right)}{\Gamma_q\left(\frac{1}{2}(v_1 + v_2), \tau\right) t!} C_{\tau}\left(\mathbf{I}_q - \Sigma_1^{\frac{1}{2}} \Sigma^{-1} \Sigma_1^{\frac{1}{2}}\right).
 \end{aligned} \tag{4.83}$$

Similarly as in the proof of Theorem 4.4(c), Section 4.3.1.4, it follows that

$$\Gamma_q\left(\frac{1}{2}v_3 + h - 1\right) = \pi^{\frac{q(q-1)}{4}} \prod_{j=1}^q \Gamma[b_j + h], \tag{see (4.40)}$$

where  $b_j = \frac{1}{2}v_3 - \frac{1}{2}(j + 1)$ ,  $j = 1, \dots, q$ ,

and

#### 4. GENERALISED BIMATRIX VARIATE BETA TYPE II DISTRIBUTIONS

##### 4.3. The generalised bimatrix variate beta type II distributions

$$\Gamma_q \left( \frac{1}{2} (v_1 + v_2) - h + 1, \tau \right) = \pi^{\frac{q(q-1)}{4}} \prod_{j=1}^q \Gamma [1 - a_j - h], \quad (\text{see (4.41)})$$

where  $a_j = -\frac{1}{2} (v_1 + v_2) - t_j + \frac{1}{2} (j - 1)$ ,  $j = 1, 2, \dots, q$ .

Substituting (4.40) and (4.41) in (4.83) gives

$$\begin{aligned} M_f(h) &= \frac{|\Sigma|^{-\frac{1}{2}v_1} |\Sigma_1|^{\frac{1}{2}v_1}}{\Gamma_q \left( \frac{1}{2}v_1 \right) \Gamma_q \left( \frac{1}{2}v_3 \right)} \sum_{t=0}^{\infty} \sum_{\tau} \frac{\Gamma_q \left( \frac{1}{2}v_1, \tau \right)}{\Gamma_q \left( \frac{1}{2} (v_1 + v_2), \tau \right) t!} \pi^{\frac{q(q-1)}{2}} \\ &\quad \times \prod_{j=1}^q \Gamma [1 - a_j - h] \prod_{j=1}^q \Gamma [b_j + h] C_{\tau} \left( \mathbf{I}_q - \Sigma_1^{\frac{1}{2}} \Sigma^{-1} \Sigma_1^{\frac{1}{2}} \right). \end{aligned} \quad (4.84)$$

From the inverse Mellin transform (see (B.15)) of (4.84) and the definition of the Meijer's G-function (see (B.16)), the pdf of  $|\mathbf{U}_1|$  is

$$\begin{aligned} f(|\mathbf{U}_1|) &= \frac{1}{2\pi i} \int_{\omega-i\infty}^{\omega+i\infty} M_f(h) |\mathbf{U}_1|^{-h} dh \\ &= \frac{|\Sigma_1|^{\frac{1}{2}v_1} |\Sigma|^{-\frac{1}{2}v_1}}{\Gamma_q \left( \frac{1}{2}v_1 \right) \Gamma_q \left( \frac{1}{2}v_3 \right)} \sum_{t=0}^{\infty} \sum_{\tau} \frac{\Gamma_q \left( \frac{1}{2}v_1, \tau \right)}{\Gamma_q \left( \frac{1}{2} (v_1 + v_2), \tau \right) t!} \frac{1}{t!} C_{\tau} \left( \mathbf{I}_q - \Sigma_1^{\frac{1}{2}} \Sigma^{-1} \Sigma_1^{\frac{1}{2}} \right) \pi^{\frac{q(q-1)}{2}} \\ &\quad \times \frac{1}{2\pi i} \int_{\omega-i\infty}^{\omega+i\infty} \prod_{j=1}^q \Gamma [b_j + h] \prod_{j=1}^q \Gamma [1 - a_j - h] |\mathbf{U}_1|^{-h} dh \\ &= \frac{|\Sigma_1|^{\frac{1}{2}v_1} |\Sigma|^{-\frac{1}{2}v_1} \pi^{\frac{q(q-1)}{2}}}{\Gamma_q \left( \frac{1}{2}v_1 \right) \Gamma_q \left( \frac{1}{2}v_3 \right)} \sum_{t=0}^{\infty} \sum_{\tau} \frac{\Gamma_q \left( \frac{1}{2}v_1, \tau \right)}{\Gamma_q \left( \frac{1}{2} (v_1 + v_2), \tau \right) t!} \frac{1}{t!} C_{\tau} \left( \mathbf{I}_q - \Sigma_1^{\frac{1}{2}} \Sigma^{-1} \Sigma_1^{\frac{1}{2}} \right) G_{q,q}^{q,q} \left( |\mathbf{U}_1| \mid_{b_1, \dots, b_q}^{a_1, \dots, a_q} \right). \end{aligned}$$

(d) Let  $u = |\mathbf{U}_1|$ ,  $u > 0$  then from (4.77) the CDF is defined as

$$\begin{aligned} F_{|\mathbf{U}_1|}(c) &= \Pr (|\mathbf{U}_1| \leq c) \\ &= \frac{\pi^{\frac{q(q-1)}{2}} |\Sigma|^{-\frac{1}{2}v_1} |\Sigma_1|^{\frac{1}{2}v_1}}{\Gamma_q \left( \frac{1}{2}v_1 \right) \Gamma_q \left( \frac{1}{2}v_3 \right)} \\ &\quad \times \sum_{t=0}^{\infty} \sum_{\tau} \frac{\Gamma_q \left( \frac{1}{2}v_1, \tau \right)}{\Gamma_q \left( \frac{1}{2} (v_1 + v_2), \tau \right) t!} \frac{1}{t!} C_{\tau} \left( \mathbf{I}_q - \Sigma_1^{\frac{1}{2}} \Sigma^{-1} \Sigma_1^{\frac{1}{2}} \right) \int_0^c G_{q,q}^{q,q} \left( u \mid_{b_1, \dots, b_q}^{a_1, \dots, a_q} \right) du. \end{aligned}$$



4. GENERALISED BIMATRIX VARIATE BETA TYPE II DISTRIBUTIONS  
 4.3. The generalised bimatrix variate beta type II distributions

---

Applying (B.27), (B.28) and (B.25), yields the desired result:

$$\begin{aligned}
 & F_{|\mathbf{U}_1|}(c) \\
 &= \frac{\pi^{\frac{q(q-1)}{2}} |\boldsymbol{\Sigma}|^{-\frac{1}{2}v_1} |\boldsymbol{\Sigma}_1|^{\frac{1}{2}v_1}}{\Gamma_q\left(\frac{1}{2}v_1\right) \Gamma_q\left(\frac{1}{2}v_3\right)} \\
 & \quad \times \sum_{t=0}^{\infty} \sum_{\tau} \frac{\Gamma_q\left(\frac{1}{2}v_1, \tau\right)}{\Gamma_q\left(\frac{1}{2}(v_1+v_2), \tau\right)} \frac{1}{t!} C_{\tau} \left(\mathbf{I}_q - \boldsymbol{\Sigma}_1^{\frac{1}{2}} \boldsymbol{\Sigma}^{-1} \boldsymbol{\Sigma}_1^{\frac{1}{2}}\right) \int_0^c H_{q,q}^{q,q} \left(u \middle| \begin{matrix} (a_1,1), \dots, (a_q,1) \\ (b_1,1), \dots, (b_q,1) \end{matrix}\right) du \\
 &= \frac{\pi^{\frac{q(q-1)}{2}} |\boldsymbol{\Sigma}|^{-\frac{1}{2}v_1} |\boldsymbol{\Sigma}_1|^{\frac{1}{2}v_1}}{\Gamma_q\left(\frac{1}{2}v_1\right) \Gamma_q\left(\frac{1}{2}v_3\right)} \\
 & \quad \times \sum_{t=0}^{\infty} \sum_{\tau} \frac{\Gamma_q\left(\frac{1}{2}v_1, \tau\right)}{\Gamma_q\left(\frac{1}{2}(v_1+v_2), \tau\right)} \frac{1}{t!} C_{\tau} \left(\mathbf{I}_q - \boldsymbol{\Sigma}_1^{\frac{1}{2}} \boldsymbol{\Sigma}^{-1} \boldsymbol{\Sigma}_1^{\frac{1}{2}}\right) c H_{q+1,q+1}^{q,q+1} \left(c \middle| \begin{matrix} (0,1), (a_1,1), \dots, (a_q,1) \\ (b_1,1), \dots, (b_q,1), (-1,1) \end{matrix}\right) \\
 &= \frac{\pi^{\frac{q(q-1)}{2}} |\boldsymbol{\Sigma}|^{-\frac{1}{2}v_1} |\boldsymbol{\Sigma}_1|^{\frac{1}{2}v_1}}{\Gamma_q\left(\frac{1}{2}v_1\right) \Gamma_q\left(\frac{1}{2}v_3\right)} \\
 & \quad \times \sum_{t=0}^{\infty} \sum_{\tau} \frac{\Gamma_q\left(\frac{1}{2}v_1, \tau\right)}{\Gamma_q\left(\frac{1}{2}(v_1+v_2), \tau\right)} \frac{1}{t!} C_{\tau} \left(\mathbf{I}_q - \boldsymbol{\Sigma}_1^{\frac{1}{2}} \boldsymbol{\Sigma}^{-1} \boldsymbol{\Sigma}_1^{\frac{1}{2}}\right) c G_{q+1,q+1}^{q,q+1} \left(c \middle| \begin{matrix} 0, a_1, \dots, a_q \\ b_1, \dots, b_q, -1 \end{matrix}\right) \\
 &= \frac{\pi^{\frac{q(q-1)}{2}} |\boldsymbol{\Sigma}|^{-\frac{1}{2}v_1} |\boldsymbol{\Sigma}_1|^{\frac{1}{2}v_1}}{\Gamma_q\left(\frac{1}{2}v_1\right) \Gamma_q\left(\frac{1}{2}v_3\right)} \\
 & \quad \times \sum_{t=0}^{\infty} \sum_{\tau} \frac{\Gamma_q\left(\frac{1}{2}v_1, \tau\right)}{\Gamma_q\left(\frac{1}{2}(v_1+v_2), \tau\right)} \frac{1}{t!} C_{\tau} \left(\mathbf{I}_q - \boldsymbol{\Sigma}_1^{\frac{1}{2}} \boldsymbol{\Sigma}^{-1} \boldsymbol{\Sigma}_1^{\frac{1}{2}}\right) G_{q+1,q+1}^{q,q+1} \left(c \middle| \begin{matrix} 1, a_1+1, \dots, a_q+1 \\ b_1+1, \dots, b_q+1, 0 \end{matrix}\right).
 \end{aligned}$$

(e) From (4.68), expanding the Gauss hypergeometric function of matrix argument in series form using (C.49) and (C.40), the Mellin transform (see (B.14)) of  $f(|\mathbf{U}_0\mathbf{U}_1|)$  is

$$\begin{aligned}
 & M_f(h) \\
 & \equiv E \left( (|\mathbf{U}_0\mathbf{U}_1|)^{h-1} \right) \\
 &= \frac{\Gamma_q\left(\frac{1}{2}(v_1+v_2) - h + 1\right) \Gamma_q\left(\frac{1}{2}v_3 + h - 1\right) \Gamma_q\left(\frac{1}{2}v_1 - h + 1\right) \Gamma_q\left(\frac{1}{2}v_2 + h - 1\right)}{\Gamma_q\left(\frac{1}{2}v_1\right) \Gamma_q\left(\frac{1}{2}v_2\right) \Gamma_q\left(\frac{1}{2}v_3\right) \Gamma_q\left(\frac{1}{2}(v_1+v_2)\right)} \\
 & \quad \times |\boldsymbol{\Sigma}|^{-\frac{1}{2}v_1} |\boldsymbol{\Sigma}_1|^{\frac{1}{2}v_1} \\
 & \quad \times {}_2F_1 \left( \frac{1}{2}v_1 - h + 1, \frac{1}{2}(v_1+v_2) - h + 1; \frac{1}{2}(v_1+v_2); \mathbf{I}_q - \boldsymbol{\Sigma}_1^{\frac{1}{2}} \boldsymbol{\Sigma}^{-1} \boldsymbol{\Sigma}_1^{\frac{1}{2}} \right)
 \end{aligned}$$

## 4. GENERALISED BIMATRIX VARIATE BETA TYPE II DISTRIBUTIONS

## 4.3. The generalised bimatrix variate beta type II distributions

$$\begin{aligned}
 &= \frac{\Gamma_q\left(\frac{1}{2}(v_1+v_2)-h+1\right)\Gamma_q\left(\frac{1}{2}v_3+h-1\right)\Gamma_q\left(\frac{1}{2}v_1-h+1\right)\Gamma_q\left(\frac{1}{2}v_2+h-1\right)}{\Gamma_q\left(\frac{1}{2}v_1\right)\Gamma_q\left(\frac{1}{2}v_2\right)\Gamma_q\left(\frac{1}{2}v_3\right)\Gamma_q\left(\frac{1}{2}(v_1+v_2)\right)} \\
 &\quad \times |\Sigma|^{-\frac{1}{2}v_1} |\Sigma_1|^{\frac{1}{2}v_1} \\
 &\quad \times \sum_{t=0}^{\infty} \sum_{\tau} \frac{\left(\frac{1}{2}v_1-h+1\right)_{\tau} \left(\frac{1}{2}(v_1+v_2)-h+1\right)_{\tau} C_{\tau}\left(\mathbf{I}_q - \Sigma_1^{\frac{1}{2}} \Sigma^{-1} \Sigma_1^{\frac{1}{2}}\right)}{\left(\frac{1}{2}(v_1+v_2)\right)_{\tau} t!} \\
 &= \frac{\Gamma_q\left(\frac{1}{2}(v_1+v_2)-h+1\right)\Gamma_q\left(\frac{1}{2}v_3+h-1\right)\Gamma_q\left(\frac{1}{2}v_1-h+1\right)\Gamma_q\left(\frac{1}{2}v_2+h-1\right)}{\Gamma_q\left(\frac{1}{2}v_1\right)\Gamma_q\left(\frac{1}{2}v_2\right)\Gamma_q\left(\frac{1}{2}v_3\right)\Gamma_q\left(\frac{1}{2}(v_1+v_2)\right)} \\
 &\quad \times |\Sigma|^{-\frac{1}{2}v_1} |\Sigma_1|^{\frac{1}{2}v_1} \\
 &\quad \times \sum_{t=0}^{\infty} \sum_{\tau} \frac{\Gamma_q\left(\frac{v_1}{2}-h+1, \tau\right)\Gamma_q\left(\frac{v_1+v_2}{2}-h+1, \tau\right)\Gamma_q\left(\frac{v_1+v_2}{2}\right) C_{\tau}\left(\mathbf{I}_q - \Sigma_1^{\frac{1}{2}} \Sigma^{-1} \Sigma_1^{\frac{1}{2}}\right)}{\Gamma_q\left(\frac{v_1}{2}-h+1\right)\Gamma_q\left(\frac{v_1+v_2}{2}-h+1\right)\Gamma_q\left(\frac{v_1+v_2}{2}, \tau\right) t!} \\
 &= \frac{\Gamma_q\left(\frac{1}{2}v_3+h-1\right)\Gamma_q\left(\frac{1}{2}v_2+h-1\right)}{\Gamma_q\left(\frac{1}{2}v_1\right)\Gamma_q\left(\frac{1}{2}v_2\right)\Gamma_q\left(\frac{1}{2}v_3\right)} |\Sigma|^{-\frac{1}{2}v_1} |\Sigma_1|^{\frac{1}{2}v_1} \tag{4.85} \\
 &\quad \times \sum_{t=0}^{\infty} \sum_{\tau} \frac{\Gamma_q\left(\frac{1}{2}v_1-h+1, \tau\right)\Gamma_q\left(\frac{1}{2}(v_1+v_2)-h+1, \tau\right) C_{\tau}\left(\mathbf{I}_q - \Sigma_1^{\frac{1}{2}} \Sigma^{-1} \Sigma_1^{\frac{1}{2}}\right)}{\Gamma_q\left(\frac{1}{2}(v_1+v_2), \tau\right) t!}.
 \end{aligned}$$

Similarly as in the proof of Theorem 4.4(e), Section 4.3.1.4, it follows that

$$\begin{aligned}
 &\Gamma_q\left(\frac{1}{2}v_3+h-1\right)\Gamma_q\left(\frac{1}{2}v_2+h-1\right) \\
 &= \pi^{\frac{p(p-1)}{2}} \prod_{j=1}^{2q} \Gamma[b_j+h], \tag{see (4.44)} \\
 &\text{with } b_j = \begin{cases} \frac{1}{2}v_3-1-\frac{(j-1)}{4} & \text{for } j=1, 3, \dots, 2q-1 \\ \frac{1}{2}v_2-1-\frac{(j-2)}{4} & \text{for } j=2, 4, \dots, 2q, \end{cases}
 \end{aligned}$$

and

$$\begin{aligned}
 &\Gamma_q\left(\frac{1}{2}v_1-h+1, \tau\right)\Gamma_q\left(\frac{1}{2}(v_1+v_2)-h+1, \tau\right) \\
 &= \pi^{\frac{q(q-1)}{2}} \prod_{j=1}^{2q} \Gamma[1-a_j-h], \tag{see (4.45)} \\
 &\text{with } a_j = \begin{cases} -\frac{1}{2}v_1-t_{\frac{j+1}{2}}+\frac{1}{4}(j-1) & \text{for } j=1, 3, \dots, 2q-1 \\ -\frac{1}{2}(v_1+v_2)-t_{\frac{j}{2}}+\frac{1}{4}(j-2) & \text{for } j=2, 4, \dots, 2q. \end{cases}
 \end{aligned}$$

## 4. GENERALISED BIMATRIX VARIATE BETA TYPE II DISTRIBUTIONS

### 4.3. The generalised bimatrix variate beta type II distributions

Substituting (4.44) and (4.45) in (4.85) gives

$$\begin{aligned}
 M_f(h) &= \frac{|\Sigma|^{-\frac{1}{2}v_1} |\Sigma_1|^{\frac{1}{2}v_1}}{\Gamma_q\left(\frac{1}{2}v_1\right) \Gamma_q\left(\frac{1}{2}v_2\right) \Gamma_q\left(\frac{1}{2}v_3\right)} \\
 &\quad \times \sum_{t=0}^{\infty} \sum_{\tau} \frac{\pi^{p(p-1)} \prod_{j=1}^{2q} \Gamma[b_j+h] \prod_{j=1}^{2q} \Gamma[1-a_j-h]}{\Gamma_q\left(\frac{1}{2}(v_1+v_2), \tau\right) t!} C_{\tau}\left(\mathbf{I}_q - \Sigma_1^{\frac{1}{2}} \Sigma^{-1} \Sigma_1^{\frac{1}{2}}\right).
 \end{aligned} \tag{4.86}$$

The pdf of  $|\mathbf{U}_0 \mathbf{U}_1|$  is obtained from the inverse Mellin transform (see (B.15)) of (4.86) and from the definition of the Meijer's G-function (see (B.16)) as

$$\begin{aligned}
 f(|\mathbf{U}_0 \mathbf{U}_1|) &= \frac{1}{2\pi i} \int_{\omega-i\infty}^{\omega+i\infty} M_f(h) (|\mathbf{U}_0 \mathbf{U}_1|)^{-h} dh \\
 &= \frac{|\Sigma|^{-\frac{1}{2}v_1} |\Sigma_1|^{\frac{1}{2}v_1}}{\Gamma_q\left(\frac{1}{2}v_1\right) \Gamma_q\left(\frac{1}{2}v_2\right) \Gamma_q\left(\frac{1}{2}v_3\right)} \sum_{t=0}^{\infty} \sum_{\tau} \frac{\pi^{q(q-1)} C_{\tau}\left(\mathbf{I}_q - \Sigma_1^{\frac{1}{2}} \Sigma^{-1} \Sigma_1^{\frac{1}{2}}\right)}{\Gamma_q\left(\frac{1}{2}(v_1+v_2), \tau\right) t!} \\
 &\quad \times \frac{1}{2\pi i} \int_{\omega-i\infty}^{\omega+i\infty} \prod_{j=1}^{2q} \Gamma[b_j+h] \prod_{j=1}^{2q} \Gamma[1-a_j-h] (|\mathbf{U}_0 \mathbf{U}_1|)^{-h} dh \\
 &= \frac{|\Sigma|^{-\frac{1}{2}v_1} |\Sigma_1|^{\frac{1}{2}v_1}}{\Gamma_q\left(\frac{1}{2}v_1\right) \Gamma_q\left(\frac{1}{2}v_2\right) \Gamma_q\left(\frac{1}{2}v_3\right)} \sum_{t=0}^{\infty} \sum_{\tau} \frac{\pi^{q(q-1)} C_{\tau}\left(\mathbf{I}_q - \Sigma_1^{\frac{1}{2}} \Sigma^{-1} \Sigma_1^{\frac{1}{2}}\right)}{\Gamma_q\left(\frac{1}{2}(v_1+v_2), \tau\right) t!} \\
 &\quad \times G_{2q,2q}^{2q,2q}\left(|\mathbf{U}_0 \mathbf{U}_1| \mid_{b_1, \dots, b_{2q}}^{a_1, \dots, a_{2q}}\right).
 \end{aligned}$$

■

**Remark 4.7** Substituting  $\Sigma = \mathbf{I}_q$  and  $\Sigma_1 = \lambda \mathbf{I}_q$  in (4.75) simplifies to (4.29),

$$\begin{aligned}
 f(|\mathbf{U}_0|) &= \frac{\pi^{\frac{q(q-1)}{2}}}{\Gamma_q\left(\frac{v_1}{2}\right) \Gamma_q\left(\frac{v_2}{2}\right)} |\lambda^{-1} \mathbf{I}_q| G_{q,q}^{q,q}\left(|\lambda^{-1} \mathbf{I}_q| |\mathbf{U}_0| \mid_{b_1, \dots, b_q}^{a_1, \dots, a_q}\right) \\
 &= \frac{\pi^{\frac{q(q-1)}{2}}}{\Gamma_q\left(\frac{v_1}{2}\right) \Gamma_q\left(\frac{v_2}{2}\right)} \lambda^{-q} G_{q,q}^{q,q}\left(\lambda^{-q} |\mathbf{U}_0| \mid_{b_1, \dots, b_q}^{a_1, \dots, a_q}\right),
 \end{aligned}$$

$$|\mathbf{U}_0| > 0.$$

**Remark 4.8** Substituting  $\Sigma = \mathbf{I}_q$  and  $\Sigma_1 = \lambda \mathbf{I}_q$  in (4.77) simplifies to (4.31),

$$\begin{aligned}
 f(|\mathbf{U}_1|) &= \frac{|\lambda \mathbf{I}_q|^{\frac{1}{2}v_1} |\mathbf{I}_q|^{-\frac{1}{2}v_1} \pi^{\frac{q(q-1)}{2}}}{\Gamma_q\left(\frac{1}{2}v_1\right) \Gamma_q\left(\frac{1}{2}v_3\right)} \sum_{t=0}^{\infty} \sum_{\tau} \frac{\Gamma_q\left(\frac{1}{2}v_1, \tau\right)}{\Gamma_q\left(\frac{1}{2}(v_1+v_2), \tau\right) t!} C_{\tau}\left(\mathbf{I}_q - \lambda \mathbf{I}_q\right) G_{q,q}^{q,q}\left(|\mathbf{U}_1| \mid_{b_1, \dots, b_q}^{a_1, \dots, a_q}\right)
 \end{aligned}$$

## 4. GENERALISED BIMATRIX VARIATE BETA TYPE II DISTRIBUTIONS

### 4.3. The generalised bimatrix variate beta type II distributions

$$\begin{aligned}
 &= \frac{\lambda^{\frac{1}{2}qv_1} \pi^{\frac{q(q-1)}{2}}}{\Gamma_q\left(\frac{1}{2}v_1\right) \Gamma_q\left(\frac{1}{2}v_3\right)} \sum_{t=0}^{\infty} \sum_{\tau} \frac{\Gamma_q\left(\frac{1}{2}v_1, \tau\right)}{\Gamma_q\left(\frac{1}{2}(v_1+v_2), \tau\right)} \frac{1}{t!} C_{\tau} \left( (1-\lambda) \mathbf{I}_q \right) G_{q,q}^{q,q} \left( |\mathbf{U}_1| \mid_{b_1, \dots, b_q}^{a_1, \dots, a_q} \right) \\
 &= \frac{\lambda^{\frac{1}{2}qv_1} \pi^{\frac{q(q-1)}{2}}}{\Gamma_q\left(\frac{1}{2}v_1\right) \Gamma_q\left(\frac{1}{2}v_3\right)} \sum_{t=0}^{\infty} \sum_{\tau} \frac{\Gamma_q\left(\frac{1}{2}v_1, \tau\right)}{\Gamma_q\left(\frac{1}{2}(v_1+v_2), \tau\right)} \frac{1}{t!} (1-\lambda)^t C_{\tau} \left( \mathbf{I}_q \right) G_{q,q}^{q,q} \left( |\mathbf{U}_1| \mid_{b_1, \dots, b_q}^{a_1, \dots, a_q} \right), \\
 & \qquad \qquad \qquad |\mathbf{U}_1| > 0.
 \end{aligned}$$

**Remark 4.9** Substituting  $\Sigma = \mathbf{I}_q$  and  $\Sigma_1 = \lambda \mathbf{I}_q$  in (4.79) simplifies to (4.33),

$$\begin{aligned}
 & f(|\mathbf{U}_0 \mathbf{U}_1|) \\
 &= \frac{|\mathbf{I}_q|^{-\frac{1}{2}v_1} |\lambda \mathbf{I}_q|^{\frac{1}{2}v_1}}{\Gamma_q\left(\frac{1}{2}v_1\right) \Gamma_q\left(\frac{1}{2}v_2\right) \Gamma_q\left(\frac{1}{2}v_3\right)} \sum_{t=0}^{\infty} \sum_{\tau} \frac{\pi^{q(q-1)} C_{\tau} \left( \mathbf{I}_q - \lambda \mathbf{I}_q \right)}{\Gamma_q\left(\frac{1}{2}(v_1+v_2), \tau\right) t!} G_{2q,2q}^{2q,2q} \left( |\mathbf{U}_0 \mathbf{U}_1| \mid_{b_1, \dots, b_{2q}}^{a_1, \dots, a_{2q}} \right) \\
 &= \frac{\lambda^{\frac{1}{2}qv_1}}{\Gamma_q\left(\frac{1}{2}v_1\right) \Gamma_q\left(\frac{1}{2}v_2\right) \Gamma_q\left(\frac{1}{2}v_3\right)} \sum_{t=0}^{\infty} \sum_{\tau} \frac{\pi^{q(q-1)} C_{\tau} \left( (1-\lambda) \mathbf{I}_q \right)}{\Gamma_q\left(\frac{1}{2}(v_1+v_2), \tau\right) t!} G_{2q,2q}^{2q,2q} \left( |\mathbf{U}_0 \mathbf{U}_1| \mid_{b_1, \dots, b_{2q}}^{a_1, \dots, a_{2q}} \right) \\
 &= \frac{\lambda^{\frac{1}{2}qv_1}}{\Gamma_q\left(\frac{1}{2}v_1\right) \Gamma_q\left(\frac{1}{2}v_2\right) \Gamma_q\left(\frac{1}{2}v_3\right)} \sum_{t=0}^{\infty} \sum_{\tau} \frac{\pi^{q(q-1)} (1-\lambda)^t C_{\tau} \left( \mathbf{I}_q \right)}{\Gamma_q\left(\frac{1}{2}(v_1+v_2), \tau\right) t!} G_{2q,2q}^{2q,2q} \left( |\mathbf{U}_0 \mathbf{U}_1| \mid_{b_1, \dots, b_{2q}}^{a_1, \dots, a_{2q}} \right), \\
 & \qquad \qquad \qquad |\mathbf{U}_0 \mathbf{U}_1| > 0.
 \end{aligned}$$

#### 4.3.2.5 Distribution of $(|\mathbf{U}_0|, |\mathbf{U}_1|)$

In Chapter 5, Section 5.3, a measure is proposed to determine the probability that a control chart will signal immediately after a change in the covariance matrix, or after one sample (i.e. the run-length probabilities). For this measure the joint distribution of  $(|\mathbf{U}_0|, |\mathbf{U}_1|)$  is of interest and will be derived in this section.

**Theorem 4.9** Suppose that  $\mathbf{X} \sim W_q(v_1, \Sigma)$  is independent of  $\mathbf{W}_0 \sim W_q(v_2, \Sigma_1)$  and  $\mathbf{W}_1 \sim W_q(v_3, \Sigma_1)$ . Then the joint pdf of  $|\mathbf{U}_0|$  and  $|\mathbf{U}_1|$  is

$$\begin{aligned}
 f(|\mathbf{U}_0|, |\mathbf{U}_1|) &= \frac{\pi^{\frac{3q(q-1)}{4}} |\mathbf{2}\Sigma|^{-1} |\mathbf{2}\Sigma_1|^{-2}}{\Gamma_q\left(\frac{1}{2}v_1\right) \Gamma_q\left(\frac{1}{2}v_2\right) \Gamma_q\left(\frac{1}{2}v_3\right)} |\mathbf{I}_q + \mathbf{U}_0| \int_0^{\infty} |\mathbf{U}|^2 G_{0,q}^{q,0} \left( \frac{|\mathbf{U}|}{|\mathbf{2}\Sigma|} \mid_{b_1, \dots, b_q} \right) \\
 & \quad \times G_{0,q}^{q,0} \left( \frac{|\mathbf{U}| |\mathbf{U}_0|}{|\mathbf{2}\Sigma_1|} \mid_{a_1, \dots, a_q} \right) G_{0,q}^{q,0} \left( \frac{|\mathbf{U}| |\mathbf{I}_q + \mathbf{U}_0| |\mathbf{U}_1|}{|\mathbf{2}\Sigma_1|} \mid_{c_1, \dots, a_{c_q}} \right) d|\mathbf{U}|,
 \end{aligned}$$

where  $|\mathbf{U}_0|, |\mathbf{U}_1| > 0$ , with  $\text{Re}(v_i) > q - 1$ ,  $i = 1, 2, 3$ .

**Proof.** From (C.60) follows

$$\frac{E|\mathbf{X}|^h}{|\mathbf{2}\Sigma|^h} = \frac{\Gamma_q\left(\frac{1}{2}v_1 + h\right)}{\Gamma_q\left(\frac{1}{2}v_1\right)}.$$

#### 4. GENERALISED BIMATRIX VARIATE BETA TYPE II DISTRIBUTIONS

##### 4.3. The generalised bimatrix variate beta type II distributions

The Mellin transform (see (B.14)) of  $f\left(\frac{|\mathbf{X}|}{|2\Sigma|}\right)$  is

$$\begin{aligned} M_f(h) &\equiv E\left(\left(\frac{|\mathbf{X}|}{|2\Sigma|}\right)^{h-1}\right) \\ &= \frac{\Gamma_q\left(\frac{1}{2}v_1 + h - 1\right)}{\Gamma_q\left(\frac{1}{2}v_1\right)}. \end{aligned} \quad (4.87)$$

From (C.35) the multivariate gamma function in (4.87) can be written as

$$\Gamma_q\left(\frac{1}{2}v_1 + h - 1\right) = \pi^{\frac{q(q-1)}{4}} \prod_{j=1}^q \Gamma[b_j + h],$$

where  $b_j = \frac{1}{2}v_1 - \frac{1}{2}(j+1)$  for  $j = 1, \dots, q$ .

The pdf of  $\frac{|\mathbf{X}|}{|2\Sigma|}$  is obtained from the inverse Mellin transform (see (B.15)) of (4.87) and from the definition of the Meijer's G-function (see (B.16)) as

$$\begin{aligned} f\left(\frac{|\mathbf{X}|}{|2\Sigma|}\right) &= \frac{1}{2\pi i} \int_{\omega-i\infty}^{\omega+i\infty} M_f(h) \left(\frac{|\mathbf{X}|}{|2\Sigma|}\right)^{-h} dh \\ &= \frac{\pi^{\frac{q(q-1)}{4}}}{\Gamma_q\left(\frac{1}{2}v_1\right)} \frac{1}{2\pi i} \int_{\omega-i\infty}^{\omega+i\infty} \prod_{j=1}^q \Gamma[b_j + h] \left(\frac{|\mathbf{X}|}{|2\Sigma|}\right)^{-h} dh \\ &= \frac{\pi^{\frac{q(q-1)}{4}}}{\Gamma_q\left(\frac{1}{2}v_1\right)} G_{0,q}^{q,0}\left(\frac{|\mathbf{X}|}{|2\Sigma|} \middle| b_1, \dots, b_q\right). \end{aligned}$$

Therefore

$$f(|\mathbf{X}|) = \frac{\pi^{\frac{q(q-1)}{4}}}{\Gamma_q\left(\frac{1}{2}v_1\right)} |2\Sigma|^{-1} G_{0,q}^{q,0}\left(\frac{|\mathbf{X}|}{|2\Sigma|} \middle| b_1, \dots, b_q\right).$$

Similarly

$$f(|\mathbf{W}_0|) = \frac{\pi^{\frac{q(q-1)}{4}}}{\Gamma_q\left(\frac{1}{2}v_2\right)} |2\Sigma_1|^{-1} G_{0,q}^{q,0}\left(\frac{|\mathbf{W}_0|}{|2\Sigma_1|} \middle| a_1, \dots, a_q\right),$$

where  $a_j = \frac{1}{2}v_2 - \frac{1}{2}(j+1)$  for  $j = 1, \dots, q$ ,

and

$$f(|\mathbf{W}_1|) = \frac{\pi^{\frac{q(q-1)}{4}}}{\Gamma_q\left(\frac{1}{2}v_3\right)} |2\Sigma_1|^{-1} G_{0,q}^{q,0}\left(\frac{|\mathbf{W}_1|}{|2\Sigma_1|} \middle| c_1, \dots, c_q\right),$$

where  $c_j = \frac{1}{2}v_3 - \frac{1}{2}(j+1)$  for  $j = 1, \dots, q$ .

## 4. GENERALISED BIMATRIX VARIATE BETA TYPE II DISTRIBUTIONS

### 4.4. Conclusion

The joint pdf of  $|\mathbf{X}|, |\mathbf{W}_0|, |\mathbf{W}_1|$  is given by

$$f(|\mathbf{X}|, |\mathbf{W}_0|, |\mathbf{W}_1|) = C G_{0,q}^{q,0} \left( \frac{|\mathbf{X}|}{|2\boldsymbol{\Sigma}|} \Big|_{b_1, \dots, b_q} \right) G_{0,q}^{q,0} \left( \frac{|\mathbf{W}_0|}{|2\boldsymbol{\Sigma}_1|} \Big|_{a_1, \dots, a_q} \right) G_{0,q}^{q,0} \left( \frac{|\mathbf{W}_1|}{|2\boldsymbol{\Sigma}_1|} \Big|_{c_1, \dots, c_q} \right),$$

where  $C = \frac{\pi^{\frac{3q(q-1)}{4}} |2\boldsymbol{\Sigma}|^{-1} |2\boldsymbol{\Sigma}_1|^{-2}}{\Gamma_q(\frac{1}{2}v_1) \Gamma_q(\frac{1}{2}v_2) \Gamma_q(\frac{1}{2}v_3)}$ .

Making the transformation

$$\mathbf{U} = \mathbf{X}, \quad \mathbf{U}_0 = \mathbf{X}^{-\frac{1}{2}} \mathbf{W}_0 \mathbf{X}^{-\frac{1}{2}}, \quad \mathbf{U}_1 = (\mathbf{X} + \mathbf{W}_0)^{-\frac{1}{2}} \mathbf{W}_1 (\mathbf{X} + \mathbf{W}_0)^{-\frac{1}{2}},$$

give

$$\mathbf{X} = \mathbf{U}, \quad \mathbf{W}_0 = \mathbf{U}^{\frac{1}{2}} \mathbf{U}_0 \mathbf{U}^{\frac{1}{2}}, \quad \mathbf{W}_1 = \left( \mathbf{U}^{\frac{1}{2}} (\mathbf{I}_q + \mathbf{U}_0) \mathbf{U}^{\frac{1}{2}} \right)^{\frac{1}{2}} \mathbf{U}_1 \left( \mathbf{U}^{\frac{1}{2}} (\mathbf{I}_q + \mathbf{U}_0) \mathbf{U}^{\frac{1}{2}} \right)^{\frac{1}{2}}.$$

Therefore  $|\mathbf{X}| = |\mathbf{U}|$ ,  $|\mathbf{W}_0| = |\mathbf{U}| |\mathbf{U}_0|$  and  $|\mathbf{W}_1| = \left| \mathbf{U}^{\frac{1}{2}} (\mathbf{I}_q + \mathbf{U}_0) \mathbf{U}^{\frac{1}{2}} \right| |\mathbf{U}_1| = |\mathbf{U}| |\mathbf{I}_q + \mathbf{U}_0| |\mathbf{U}_1|$  with Jacobian (see (C.41))

$$J(|\mathbf{X}|, |\mathbf{W}_0|, |\mathbf{W}_1| \rightarrow |\mathbf{U}|, |\mathbf{U}_0|, |\mathbf{U}_1|) = |\mathbf{U}|^2 |\mathbf{I}_q + \mathbf{U}_0|.$$

The joint pdf of  $|\mathbf{U}|, |\mathbf{U}_0|$  and  $|\mathbf{U}_1|$  is

$$\begin{aligned} f(|\mathbf{U}|, |\mathbf{U}_0|, |\mathbf{U}_1|) &= C G_{0,q}^{q,0} \left( \frac{|\mathbf{U}|}{|2\boldsymbol{\Sigma}|} \Big|_{b_1, \dots, b_q} \right) G_{0,q}^{q,0} \left( \frac{|\mathbf{U}| |\mathbf{U}_0|}{|2\boldsymbol{\Sigma}_1|} \Big|_{a_1, \dots, a_q} \right) \\ &\quad \times G_{0,q}^{q,0} \left( \frac{|\mathbf{U}| |\mathbf{I}_q + \mathbf{U}_0| |\mathbf{U}_1|}{|2\boldsymbol{\Sigma}_1|} \Big|_{c_1, \dots, c_q} \right) |\mathbf{I}_q + \mathbf{U}_0| |\mathbf{U}|^2. \end{aligned}$$

Thus, the joint pdf of  $|\mathbf{U}_0|$  and  $|\mathbf{U}_1|$  is

$$\begin{aligned} f(|\mathbf{U}_0|, |\mathbf{U}_1|) &= C |\mathbf{I}_q + \mathbf{U}_0| \int_0^\infty |\mathbf{U}|^2 G_{0,q}^{q,0} \left( \frac{|\mathbf{U}|}{|2\boldsymbol{\Sigma}|} \Big|_{b_1, \dots, b_q} \right) G_{0,q}^{q,0} \left( \frac{|\mathbf{U}| |\mathbf{U}_0|}{|2\boldsymbol{\Sigma}_1|} \Big|_{a_1, \dots, a_q} \right) \\ &\quad \times G_{0,q}^{q,0} \left( \frac{|\mathbf{U}| |\mathbf{I}_q + \mathbf{U}_0| |\mathbf{U}_1|}{|2\boldsymbol{\Sigma}_1|} \Big|_{c_1, \dots, c_q} \right) d|\mathbf{U}|. \end{aligned}$$

■

## 4.4 Conclusion

In this chapter the bimatrix variate beta type II distribution that originated from Wishart ratios is introduced. This distribution originates from monitoring the process covariance structure of  $q$  attributes where samples are independent, having been collected from a

## 4. GENERALISED BIMATRIX VARIATE BETA TYPE II DISTRIBUTIONS

### 4.4. Conclusion

---

multivariate normal distribution with known mean vector and unknown covariance matrix. The case where the covariance matrix changes with a scale factor as well as a more general case were discussed. The product moments of these new distributions were explored since they were needed to derive the pdfs of the determinants of the statistics of interest. The latter is required in Chapter 5.

The exact expressions of the pdfs are in terms of zonal polynomials, hypergeometric functions of matrix argument and Meijer's G-function. These functions are computable due to the availability of packages (for example the Mathematica software package) and algorithms (see Koev and Edelman, 2006 [25]). The computational aspect of the run-length probabilities will be considered in Chapter 5.

# Chapter 5

## Illustrative examples

The usefulness of the exact expressions for the pdfs of the newly derived distributions will be illustrated in this chapter. Note that there are other methods available to calculate the probabilities stemming from the sequential quality monitoring procedure, which are also briefly addressed in this chapter.

The following will be addressed in this chapter:

- Calculation of the run-length probabilities if the unknown process variance changes; this is done using the generalised multivariate beta type II pdf. Other methods to calculate these run-length probabilities are also included (Section 5.1).
- Calculation of the run-length probabilities if both the unknown process variance and the known process mean changes. The focus will be on the effect of the noncentrality parameter of the noncentral generalised multivariate beta type II distribution (Section 5.2).
- Tabulation of some percentage points of  $|\mathbf{U}_0|$  as an avenue to address the calculation of run-length probabilities within the matrix environment (Section 5.3).

### 5.1 Run-length probabilities if the unknown process variance has changed

This section considers a practical application in the SPC environment where the proposed distribution (see (2.8)) is used to calculate run-length probabilities. In Section 5.1.1 the generalised multivariate beta type II distribution is used to determine the probability that a Q-chart will signal after the process variance encountered a sustained shift. For



## 5. ILLUSTRATIVE EXAMPLES

### 5.1. Run-length probabilities if the unknown process variance has changed

---

comparison purposes these probabilities will also be calculated by means of (i) an approximate method using simulation, (ii) an approximation assuming independence and (iii) an exact method using a conditioning and unconditioning approach. These alternative methods are discussed in Sections 5.1.2, 5.1.3 and 5.1.4, respectively.

The example used throughout this section is a continuation of the example in Section 1.2 where a Q-chart was used to monitor the process variance of a normal random variable using twenty samples of size four each. The first ten samples of the simulated data set were generated from a  $N(10, 1)$  distribution; the next ten samples from a  $N(10, 2)$  distribution. The simulated data and Q-chart is given in Table 1.1 and Figure 1.2, respectively. Based on the information of the simulated data set, it is evident that  $\lambda = 2$  (variance increased by a factor of 2),  $v_j = n_j = n = 4$  (equal sample sizes at each point in time),  $\kappa = 11$  (the process variance encountered a shift between samples ten and eleven) and thus  $a = (\kappa - 1) \times n = 40$  (forty observations were available to estimate the unknown variance before the shift occurred). The goal is to calculate the probabilities that the control chart will signal that the process is out-of-control on samples one, two and three following the shift.

Once a shift in the process parameter occurred, the run-length is the number of samples collected from time  $\kappa$  (i.e. first sample after the change) until an out-of-control signal is observed (i.e. a charting statistic plots on or outside the control limits). The discrete random variable defining the run-length is called the run-length random variable and typically denoted by  $N$ . The distribution of  $N$  is called the run-length distribution.

Let  $A_j$  be the event that the random variable  $U_j$ ,  $j = 0, 1, \dots, p$ , plots inside its respective control limits, i.e.

$$A_j = LCL_{\kappa+j} < U_j < UCL_{\kappa+j}. \quad (5.1)$$

The probability of detecting a shift immediately, in other words, the probability of a run-length of one is then

$$\begin{aligned} \Pr(N = 1) &= \Pr(A_0^C) \\ &= 1 - \Pr(A_0) \\ &= 1 - \Pr(LCL_{\kappa} < U_0 < UCL_{\kappa}). \end{aligned} \quad (5.2)$$

**Remark 5.1** Take note that (5.2) is the probability that the control chart will signal on the first sample collected after there was a change in the process variance. This is

## 5. ILLUSTRATIVE EXAMPLES

### 5.1. Run-length probabilities if the unknown process variance has changed

essentially a conditional probability that the control chart will signal given that the process is out-of-control.

#### 5.1.1 The generalised distribution approach

The generalised multivariate beta type II distribution can be used to calculate probabilities that a charting statistic will plot inside or outside the control limits. The probability of detecting a shift immediately (see (5.2)), is the likelihood that a signal is obtained at time  $\kappa$ ,

$$\begin{aligned}
 \Pr(N = 1) &= 1 - \int_{LCL}^{UCL} f(u_0^*) du_0^* && \text{(see (2.4))} \\
 &= 1 - \int_{LCL_\kappa}^{UCL_\kappa} f(u_0) du_0. && \text{(see (2.7))}
 \end{aligned} \tag{5.3}$$

The marginal pdf of  $U_0$  (see (2.24)) can therefore be used to determine the probability of detecting the shift in the process variance immediately, i.e. when collecting the first sample after the shift took place. The difference between the random variables  $U_0^*$  (see (2.4)) and  $U_0$  (see (2.7)) will be incorporated in the limits of integration. Note that  $LCL_\kappa$  and  $UCL_\kappa$  depend on  $\kappa$  whereas  $LCL$  and  $UCL$  equals  $-3$  and  $3$ , respectively (regardless the value of  $\kappa$ ).

The limits of integration,  $LCL_\kappa$  and  $UCL_\kappa$ , will be discussed next.

When the process is in-control, i.e.  $\lambda = 1$ ,  $U_0^* = \frac{W_0/n_\kappa}{X/\sum_{i=1}^{\kappa-1} n_i} \sim F(n_\kappa, \sum_{i=1}^{\kappa-1} n_i)$  (see Remark 2.1), then the Q charting statistic is given by

$$Q(U_0^*) = \Phi^{-1} \left[ F_{n_\kappa, \sum_{i=1}^{\kappa-1} n_i}(U_0^*) \right],$$

and the control limits  $UCL_\kappa$  and  $LCL_\kappa$  are determined as follows:

$$\begin{aligned}
 -3 &< \Phi^{-1} \left[ F_{n_\kappa, \sum_{i=1}^{\kappa-1} n_i}(U_0^*) \right] < 3 \\
 \iff \Phi(-3) &< F_{n_\kappa, \sum_{i=1}^{\kappa-1} n_i}(U_0^*) < \Phi(3) \\
 \iff F_{n_\kappa, \sum_{i=1}^{\kappa-1} n_i}^{-1}[\Phi(-3)] &< U_0^* < F_{n_\kappa, \sum_{i=1}^{\kappa-1} n_i}^{-1}[\Phi(3)] \\
 \iff \frac{F_{n_\kappa, \sum_{i=1}^{\kappa-1} n_i}^{-1}[\Phi(-3)]}{\frac{\sum_{i=1}^{\kappa-1} n_i}{n_\kappa}} &< U_0 < \frac{F_{n_\kappa, \sum_{i=1}^{\kappa-1} n_i}^{-1}[\Phi(3)]}{\frac{\sum_{i=1}^{\kappa-1} n_i}{n_\kappa}}.
 \end{aligned}$$

## 5. ILLUSTRATIVE EXAMPLES

### 5.1. Run-length probabilities if the unknown process variance has changed

$$\text{Therefore } UCL_{L\kappa} = \frac{F^{-1}_{n_{\kappa}, \sum_{i=1}^{\kappa-1} n_i} [\Phi(3)]}{\sum_{i=1}^{\kappa-1} n_i} \text{ and } LCL_{L\kappa} = \frac{F^{-1}_{n_{\kappa}, \sum_{i=1}^{\kappa-1} n_i} [\Phi(-3)]}{\sum_{i=1}^{\kappa-1} n_i},$$

where

$F(v_1, v_2)$  denotes the F distribution with  $v_1$  and  $v_2$  degrees of freedom;

$F_{v_1, v_2}(\cdot)$  denotes the cumulative distribution function of the  $F(v_1, v_2)$  distribution;

$F_{v_1, v_2}^{-1}(\cdot)$  denotes the inverse of the cumulative distribution function of the  $F(v_1, v_2)$  distribution;

$\Phi(\cdot)$  denotes the standard normal cumulative distribution function; and

$\Phi^{-1}(\cdot)$  denotes the inverse of the standard normal cumulative distribution function.

In general, at time  $\kappa + j$ , the limits of integration will be

$$UCL_{L\kappa+j} = \frac{F^{-1}_{n_{\kappa+j}, \sum_{i=1}^{\kappa+j-1} n_i} [\Phi(3)]}{\sum_{i=1}^{\kappa+j-1} n_i} \text{ and } LCL_{L\kappa+j} = \frac{F^{-1}_{n_{\kappa+j}, \sum_{i=1}^{\kappa+j-1} n_i} [\Phi(-3)]}{\sum_{i=1}^{\kappa+j-1} n_i}, \quad (5.4)$$

since the control limits of the control chart are based on the in-control distribution of the process (i.e. when  $\lambda = 1$ ).

The probability of a the run-length of two is the probability of not detecting the shift at time  $\kappa$ , i.e. the charting statistic  $U_0$  plots inside the control limits, but the control chart signals at time  $\kappa + 1$ , i.e.  $U_1$  plots on or outside the control limits. Therefore

$$\begin{aligned} & \Pr(N = 2) \\ &= \Pr(A_0 \cap A_1^c) \\ &= \Pr(A_0) - \Pr(A_0 \cap A_1) \\ &= \int_{LCL_{L\kappa}}^{UCL_{L\kappa}} f(u_0) du_0 - \int_{LCL_{L\kappa+1}}^{UCL_{L\kappa+1}} \int_{LCL_{L\kappa}}^{UCL_{L\kappa}} f(u_0, u_1) du_0 du_1. \end{aligned} \quad (5.5)$$

The run-length probabilities for higher values of  $N$  can be determined in a similar fashion.

## 5. ILLUSTRATIVE EXAMPLES

 5.1. Run-length probabilities if the unknown process variance has changed
 

---

The probability of a run-length of  $\eta$  is then

$$\begin{aligned}
 \Pr(N = \eta) &= \Pr\left(\bigcap_{j=0}^{\eta-2} A_j \cap A_{\eta-1}^C\right) \\
 &= \int_{LCL_{\kappa+\eta-2}}^{UCL_{\kappa+\eta-2}} \cdots \int_{LCL_{\kappa}}^{UCL_{\kappa}} f(u_0, \dots, u_{\eta-2}) du_0 \cdots du_{\eta-2} \\
 &\quad - \int_{LCL_{\kappa+\eta-1}}^{UCL_{\kappa+\eta-1}} \cdots \int_{LCL_{\kappa}}^{UCL_{\kappa}} f(u_0, \dots, u_{\eta-1}) du_0 \cdots du_{\eta-1} \\
 &\quad \text{for } \eta = 2, 3, \dots
 \end{aligned} \tag{5.6}$$

The run-length probabilities, up to  $N = 3$ , for the example (where  $\lambda = 2$ ,  $v_j = n = 4$ ,  $\kappa = 11$ ,  $a = \sum_{i=1}^{\kappa-1} n = (\kappa - 1) \times n = 40$ ) is calculated next. The software package Mathematica was used to calculate these probabilities. An exact solution can be obtained for  $N = 1$  while numerical integration is necessary for determining run-lengths greater than one.

The probability of detecting the shift in the process variance immediately at time period eleven is calculated using (5.3) and (2.24):

$$\begin{aligned}
 \Pr(N = 1) &= 1 - \int_{LCL_{\kappa=11}}^{UCL_{\kappa=11}} f(u_0) du_0 = 1 - \int_{0.0025837}^{0.5444577} f(u_0) du_0 \\
 &= 1 - 0.956871 = 0.043129,
 \end{aligned} \tag{5.7}$$

where, from (5.4)

$$\begin{aligned}
 LCL_{\kappa=11} &= \frac{F_{4,40}^{-1}[\Phi(-3)]}{\frac{40}{4}} = \frac{F_{4,40}^{-1}[0.001349898]}{10} = 0.0025837, \\
 UCL_{\kappa=11} &= \frac{F_{4,40}^{-1}[\Phi(3)]}{\frac{40}{4}} = \frac{F_{4,40}^{-1}[0.998650102]}{10} = 0.5444577.
 \end{aligned} \tag{5.8}$$

**Remark 5.2** *It is well-known that the type I error in hypothesis testing is  $P(\text{reject } H_0 \mid H_0 \text{ true})$ . In the SPC context this is the same as the false alarm rate (FAR). The FAR is defined as the probability for a single charting statistic to plot on or outside the control limits when the process is in-control. In terms of the example above, that is the probability that  $U_0$  plots on or outside the control limits given that the process variance did not encounter a shift, i.e.  $\lambda = 1$ .*

## 5. ILLUSTRATIVE EXAMPLES

### 5.1. Run-length probabilities if the unknown process variance has changed

---

Therefore

$$\begin{aligned} FAR &= 1 - \Pr(LCL_{\kappa} < U_0 < UCL_{\kappa} \mid \lambda = 1) \\ &= 1 - \int_{0.0025837}^{0.5444577} f(u_0) du_0 \\ &= 0.0027. \end{aligned}$$

In the SPC environment it is desirable to have a FAR of 0.0027.

The probability of detecting the shift in the process variance at time period twelve is calculated using (5.5), (2.24) and (2.39):

$$\begin{aligned} \Pr(N = 2) &= \int_{LCL_{\kappa=11}}^{UCL_{\kappa=11}} f(u_0) du_0 - \int_{LCL_{\kappa+1=12}}^{UCL_{\kappa+1=12}} \int_{LCL_{\kappa=11}}^{UCL_{\kappa=11}} f(u_0, u_1) du_0 du_1 \\ &= \int_{0.0025837}^{0.5444577} f(u_0) du_0 - \int_{0.0023536}^{0.4858039} \int_{0.0025837}^{0.5444577} f(u_0, u_1) du_0 du_1 \\ &= 0.956871 - 0.924702 = 0.032169, \end{aligned}$$

where, from (5.4)

$$\begin{aligned} LCL_{\kappa+1=12} &= \frac{F_{4,44}^{-1}[\Phi(-3)]}{\frac{44}{4}} = \frac{F_{4,44}^{-1}[0.001349898]}{11} = 0.0023536, \\ UCL_{\kappa+1=12} &= \frac{F_{4,44}^{-1}[\Phi(3)]}{\frac{44}{4}} = \frac{F_{4,44}^{-1}[0.998650102]}{11} = 0.4858039. \end{aligned} \quad (5.9)$$

Note that in calculating the above probability the form of  $f(u_0, u_1)$  used was (2.39) and not in terms of the product of beta type II pdfs (see (2.40)) since the latter form has an infinite sum.

The probability of detecting the shift in the process variance at time period thirteen is calculated using (5.6), (2.39) and (2.8) with  $p = 2$ :

$$\begin{aligned} \Pr(N = 3) &= \int_{LCL_{\kappa+1=12}}^{UCL_{\kappa+1=12}} \int_{LCL_{\kappa=11}}^{UCL_{\kappa=11}} f(u_0, u_1) du_0 du_1 \\ &\quad - \int_{LCL_{\kappa+2=13}}^{UCL_{\kappa+2=13}} \int_{LCL_{\kappa+1=12}}^{UCL_{\kappa+1=12}} \int_{LCL_{\kappa=11}}^{UCL_{\kappa=11}} f(u_0, u_1, u_2) du_0 du_1 du_2 \\ &= \int_{0.0023536}^{0.4858039} \int_{0.0025837}^{0.5444577} f(u_0, u_1) du_0 du_1 \\ &\quad - \int_{0.0021612}^{0.4384660} \int_{0.0023536}^{0.4858039} \int_{0.0025837}^{0.5444577} f(u_0, u_1, u_2) du_0 du_1 du_2 \\ &= 0.924702 - 0.899646 = 0.025056, \end{aligned}$$

where, from (5.4)

## 5. ILLUSTRATIVE EXAMPLES

### 5.1. Run-length probabilities if the unknown process variance has changed

---

$$\begin{aligned}
 LCL_{\kappa+2=13} &= \frac{F_{4,48}^{-1}[\Phi(-3)]}{\frac{48}{4}} = \frac{F_{4,48}^{-1}[0.001349898]}{12} = 0.0021612, & (5.10) \\
 UCL_{\kappa+2=13} &= \frac{F_{4,48}^{-1}[\Phi(3)]}{\frac{48}{4}} = \frac{F_{4,48}^{-1}[0.998650102]}{12} = 0.4384660.
 \end{aligned}$$

These run-length probabilities can then be used to estimate the average run-length ( $ARL$ ) using the formula  $E(N) = ARL = \sum_{\eta=1}^{\infty} \eta \Pr(N=\eta) \approx \sum_{\eta=1}^M \eta \Pr(N=\eta)$ . The accuracy of the  $ARL$  estimate will depend on the cut-off value,  $M$ . The evaluation of high dimensional multiple integrals become increasingly more complex (i.e. time consuming and resource intensive) as the dimension increases and is beyond the scope of this thesis.

In the next section the run-length probabilities calculated above (using the pdf of the generalised multivariate beta type II distribution) will be determined heuristically using Monte Carlo simulation.

#### 5.1.2 The simulation approach

The run-length probabilities for the example (where  $\lambda = 2$ ,  $v_j = 4$ ,  $\kappa = 11$ ,  $a = 40$ ) can be approximated using Monte Carlo simulation. The  $\Pr(N = \eta)$  for  $\eta = 1, 2, 3$  is calculated using the SAS software package. An algorithm of the SAS program follows:

Step 1:

Generate random numbers from the distributions of the building blocks of the random variables in (2.7), i.e.  $X \sim \chi^2(a = 40)$  and  $W_0, W_1, W_2 \sim \chi^2(v = n = 4)$ .

Step 2:

Determine  $U_0 = \frac{\lambda W_0}{X}$ ,  $U_1 = \frac{\lambda W_1}{X + \lambda W_0}$  and  $U_2 = \frac{\lambda W_2}{X + \lambda W_0 + \lambda W_1}$ .

Step 3:

Count the number of times a simulated value of the random variables lie between the limits of integration,

i.e. (a)  $count1 = 0.0025837 < U_0 < 0.5444577$ ,

(b)  $count2 = 0.0025837 < U_0 < 0.5444577$  and  $0.0023536 < U_1 < 0.48580390$ ,

(c)  $count3 = 0.0025837 < U_0 < 0.5444577$  and  $0.0023536 < U_1 < 0.48580390$

and  $0.0021612 < U_2 < 0.4384660$ .

## 5. ILLUSTRATIVE EXAMPLES

### 5.1. Run-length probabilities if the unknown process variance has changed

---

These control limits are the same as those determined in Section 5.1.1 (see (5.8), (5.9) and (5.10)).

Repeat steps 1 to 3 one million times.

Step 4:

Aggregate the results of step 3 to determine the approximate probability that the random variable(s) are inside their control limits,

$$\text{i.e. } p1 = \Pr(0.0025837 < U_0 < 0.5444577) = \frac{\text{count1}}{1000000},$$

$$p2 = \Pr(0.0025837 < U_0 < 0.5444577 \cap 0.0023536 < U_1 < 0.48580390) = \frac{\text{count2}}{1000000},$$

$$p3 = \Pr\left(\begin{array}{l} 0.0025837 < U_0 < 0.5444577 \cap 0.0023536 < U_1 < 0.48580390 \\ \cap 0.0021612 < U_2 < 0.4384660 \end{array}\right) = \frac{\text{count3}}{1000000}.$$

Step 5:

Determine the run-length probabilities analogous to (5.3), (5.5) and (5.6),

$$\text{i.e. } \Pr(N = 1) = 1 - p1$$

$$\Pr(N = 2) = p1 - p2$$

$$\Pr(N = 3) = p2 - p3.$$

The approximate run-length probabilities using this method are:  $\Pr(N = 1) = 0.043133$

$$\Pr(N = 2) = 0.032287$$

$$\Pr(N = 3) = 0.02492.$$

This method offers a straightforward approximation of the high order multiple integrals needed to determine the run-length probabilities. In Section 5.1.3 another approximate solution will be considered.

#### 5.1.3 Assuming independence

Zantek (2005) [47] studied the performance of a Q-chart in the detection of process mean shifts when observations are collected from a normal distribution. He proposed that an approximation of the run-length probabilities can be obtained by treating the charting statistics as if they are independent. The first charting statistic calculated following a shift in the variance (i.e.  $U_0$ ) is independent of each of the previous test statistics when the process was in-control; therefore an exact probability of a run-length of one can be calculated. From time period  $\kappa$  onwards, the charting statistics (i.e.  $U_0, U_1, \dots$ ) are not independent random variables and therefore the events that the chart will signal

## 5. ILLUSTRATIVE EXAMPLES

### 5.1. Run-length probabilities if the unknown process variance has changed

---

at certain time periods are not independent events. This dependency complicates the calculation of the run-length probabilities for  $N > 1$  as seen in Section 5.1.1. Treating these charting statistics as independent random variables simplifies the computational aspect of the probabilities because it reduces to the product of univariate probabilities. Following this approach, the approximate run-length probabilities can be calculated as (see also (5.3), (5.6))

$$\Pr(N = 1) = 1 - \Pr(A_0), \quad (5.11)$$

$$\Pr(N = \eta) = \prod_{j=0}^{\eta-2} \Pr(A_j) [1 - \Pr(A_{\eta-1})],$$

$$\text{where } \Pr(A_j) = \int_{LCL_{\kappa+j}}^{UCL_{\kappa+j}} f(u_j) du_j, \quad j = 0, 1, \dots, \eta - 1 \text{ for } \eta = 2, 3, \dots$$

Take note that  $\Pr(N = 1)$  is the same as the exact solution (see (5.3)) in Section 5.1.1.

Continuing with the example (where  $\lambda = 2$ ,  $v_j = 4$ ,  $\kappa = 11$ ,  $a = (n - 1) \times \kappa = 40$ ), the corresponding approximate run-length probabilities are:

$$\begin{aligned} \Pr(N = 1) &= 1 - \Pr(A_0) \\ &= 1 - \int_{0.0025837}^{0.5444577} f(u_0) du_0 \\ &= 1 - 0.956871 \\ &= 0.043129, \end{aligned}$$

$$\begin{aligned} \Pr(N = 2) &= \Pr(A_0) [1 - \Pr(A_1)] \\ &= \int_{0.0025837}^{0.5444577} f(u_0) du_0 \left[ 1 - \int_{0.0023536}^{0.4858039} f(u_1) du_1 \right] \\ &= 0.956871 \times (1 - 0.967036) \\ &= 0.031543, \end{aligned}$$

$$\begin{aligned} \Pr(N = 3) &= \Pr(A_0) \Pr(A_1) [1 - \Pr(A_2)] \\ &= \int_{0.0025837}^{0.5444577} f(u_0) du_0 \int_{0.0023536}^{0.4858039} f(u_1) du_1 \left[ 1 - \int_{0.0021612}^{0.4384660} f(u_2) du_2 \right] \\ &= 0.956871 \times 0.967036 \times (1 - 0.973753) \\ &= 0.024287. \end{aligned}$$

This method underestimates the run-length probabilities. An advantage of this approximation is that the software package Mathematica could get exact solutions of the univariate integrals evaluated. The final approach to determine the run-length probabilities that also yields an exact solution is discussed in the next section.



### 5.1.4 A conditioning approach

Section 5.1.1 described an exact approach to determine the run-length probabilities using the pdf of the generalised multivariate beta type II distribution (2.8). In this section another exact approach is discussed that makes use of the joint pdf of the independent chi-squared random variables  $X$  and  $W_j$  with  $j = 0, 1, 2, \dots, p$  with degrees of freedom  $a$  and  $v_j$  with  $j = 0, 1, 2, \dots, p$  respectively (see (2.7)). Deriving the run-length distribution can be done via the so-called "conditioning and unconditioning" approach; this involves two steps; namely:

- (i) Derive the conditional run-length distribution by conditioning on the random variable  $X$ . This random variable contains all the information prior to the change in the process variance, i.e.  $\Pr(N = \eta | X)$ .
- (ii) Obtain the unconditional run-length distribution by integrating over all possible values of the random variable  $X$ , i.e.  $\Pr(N = \eta) = E_X [\Pr(N = \eta | X)]$ .

The conditional probability that the run-length is one (see (5.1), (5.3) and (2.7)), is:

$$\begin{aligned}
 & \Pr(N = 1 | X = x) \\
 &= \Pr(A_0^C | X = x) \\
 &= 1 - \Pr(A_0 | X = x) \\
 &= 1 - \Pr(LCL_\kappa < U_0 < UCL_\kappa | X = x) \\
 &= 1 - \Pr\left(LCL_\kappa < \frac{\lambda W_0}{x} < UCL_\kappa | X = x\right) \\
 &= 1 - \Pr\left(\frac{x LCL_\kappa}{\lambda} < W_0 < \frac{x UCL_\kappa}{\lambda} | X = x\right) \\
 &= 1 - \int_{\frac{x LCL_\kappa}{\lambda}}^{\frac{x UCL_\kappa}{\lambda}} f(w_0 | x) dw_0.
 \end{aligned} \tag{5.12}$$

The unconditional probability that the run-length is one, is then from (5.12):

$$\begin{aligned}
 & \Pr(N = 1) \\
 &= E_X [\Pr(N = 1 | X)] \\
 &= \int_0^\infty \Pr(N = 1 | X = x) f(x) dx
 \end{aligned}$$

## 5. ILLUSTRATIVE EXAMPLES

### 5.1. Run-length probabilities if the unknown process variance has changed

---

$$\begin{aligned}
&= \int_0^\infty \left[ 1 - \int_{\frac{xLCL_\kappa}{\lambda}}^{\frac{xUCL_\kappa}{\lambda}} f(w_0 | x) dw_0 \right] f(x) dx \\
&= 1 - \int_0^\infty \int_{\frac{xLCL_\kappa}{\lambda}}^{\frac{xUCL_\kappa}{\lambda}} f(w_0 | x) f(x) dw_0 dx \\
&= 1 - \int_0^\infty \int_{\frac{xLCL_\kappa}{\lambda}}^{\frac{xUCL_\kappa}{\lambda}} f(x, w_0) dw_0 dx.
\end{aligned}$$

Take note that  $X$  and  $W_0$  are independent chi-squared random variables with degrees of freedom  $a$  and  $v_0$ , respectively (see Theorem 2.2), therefore

$$\Pr(N = 1) = 1 - \int_0^\infty \int_{\frac{xLCL_\kappa}{\lambda}}^{\frac{xUCL_\kappa}{\lambda}} f(x) f(w_0) dw_0 dx. \quad (5.13)$$

The conditional probability that the run-length is two (see (5.5)), is:

$$\begin{aligned}
&\Pr(N = 2 | X = x) \\
&= \Pr(A_0 \cap A_1^C | X = x) \\
&= \Pr(A_1^C | A_0, X = x) \Pr(A_0 | X = x),
\end{aligned} \quad (5.14)$$

where

$$\Pr(A_0 | X = x) = \int_{\frac{xLCL_\kappa}{\lambda}}^{\frac{xUCL_\kappa}{\lambda}} f(w_0 | x) dw_0, \quad (5.15)$$

given in (5.12). It follows from (2.7), that

$$\begin{aligned}
&\Pr(A_1^C | A_0, X = x) \\
&= 1 - \Pr(A_1 | A_0, X = x) \\
&= 1 - \Pr(LCL_{\kappa+1} < U_1 < UCL_{\kappa+1} | X = x, LCL_\kappa < U_0 < UCL_\kappa) \\
&= 1 - \Pr\left(LCL_{\kappa+1} < \frac{\lambda W_1}{x + \lambda w_0} < UCL_{\kappa+1} | X = x, W_0\right) \\
&= 1 - \Pr\left(\frac{(x + \lambda w_0) LCL_{\kappa+1}}{\lambda} < W_1 < \frac{(x + \lambda w_0) UCL_{\kappa+1}}{\lambda} | X = x, W_0\right) \\
&= 1 - \int_{\frac{(x + \lambda w_0) LCL_{\kappa+1}}{\lambda}}^{\frac{(x + \lambda w_0) UCL_{\kappa+1}}{\lambda}} f(w_1 | x, w_0) dw_1.
\end{aligned} \quad (5.16)$$

## 5. ILLUSTRATIVE EXAMPLES

### 5.1. Run-length probabilities if the unknown process variance has changed

Therefore, substituting (5.15) and (5.16) into (5.14),

$$\begin{aligned}
& \Pr(N = 2 | X = x) \\
&= \left[ 1 - \int_{\frac{(x+\lambda w_0)LCL_{\kappa+1}}{\lambda}}^{\frac{(x+\lambda w_0)UCL_{\kappa+1}}{\lambda}} f(w_1 | x, w_0) dw_1 \right] \left[ \int_{\frac{xLCL_{\kappa}}{\lambda}}^{\frac{xUCL_{\kappa}}{\lambda}} f(w_0 | x) dw_0 \right] \\
&= \int_{\frac{xLCL_{\kappa}}{\lambda}}^{\frac{xUCL_{\kappa}}{\lambda}} f(w_0 | x) dw_0 \\
&\quad - \int_{\frac{(x+\lambda w_0)LCL_{\kappa+1}}{\lambda}}^{\frac{(x+\lambda w_0)UCL_{\kappa+1}}{\lambda}} f(w_1 | x, w_0) dw_1 \int_{\frac{xLCL_{\kappa}}{\lambda}}^{\frac{xUCL_{\kappa}}{\lambda}} f(w_0 | x) dw_0.
\end{aligned} \tag{5.17}$$

Using (5.17), the unconditional probability that the run-length is two, is:

$$\begin{aligned}
& \Pr(N = 2) \\
&= E_X [\Pr(N = 2 | X)] \\
&= \int_0^{\infty} \Pr(N = 2 | X = x) f(x) dx \\
&= \int_0^{\infty} \left[ \int_{\frac{xLCL_{\kappa}}{\lambda}}^{\frac{xUCL_{\kappa}}{\lambda}} f(w_0 | x) dw_0 - \int_{\frac{(x+\lambda w_0)LCL_{\kappa+1}}{\lambda}}^{\frac{(x+\lambda w_0)UCL_{\kappa+1}}{\lambda}} f(w_1 | x, w_0) dw_1 \int_{\frac{xLCL_{\kappa}}{\lambda}}^{\frac{xUCL_{\kappa}}{\lambda}} f(w_0 | x) dw_0 \right] \\
&\quad \times f(x) dx \\
&= \int_0^{\infty} \int_{\frac{xLCL_{\kappa}}{\lambda}}^{\frac{xUCL_{\kappa}}{\lambda}} f(w_0 | x) dw_0 f(x) dx \\
&\quad - \int_0^{\infty} \int_{\frac{(x+\lambda w_0)LCL_{\kappa+1}}{\lambda}}^{\frac{(x+\lambda w_0)UCL_{\kappa+1}}{\lambda}} f(w_1 | x, w_0) dw_1 \int_{\frac{xLCL_{\kappa}}{\lambda}}^{\frac{xUCL_{\kappa}}{\lambda}} f(w_0 | x) dw_0 f(x) dx \\
&= \int_0^{\infty} \int_{\frac{xLCL_{\kappa}}{\lambda}}^{\frac{xUCL_{\kappa}}{\lambda}} f(x, w_0) dw_0 dx \\
&\quad - \int_0^{\infty} \int_{\frac{(x+\lambda w_0)LCL_{\kappa+1}}{\lambda}}^{\frac{(x+\lambda w_0)UCL_{\kappa+1}}{\lambda}} f(w_1 | x, w_0) dw_1 \int_{\frac{xLCL_{\kappa}}{\lambda}}^{\frac{xUCL_{\kappa}}{\lambda}} f(x, w_0) dw_0 dx \\
&= \int_0^{\infty} \int_{\frac{xLCL_{\kappa}}{\lambda}}^{\frac{xUCL_{\kappa}}{\lambda}} f(x, w_0) dw_0 dx - \int_0^{\infty} \int_{\frac{(x+\lambda w_0)LCL_{\kappa+1}}{\lambda}}^{\frac{(x+\lambda w_0)UCL_{\kappa+1}}{\lambda}} \int_{\frac{xLCL_{\kappa}}{\lambda}}^{\frac{xUCL_{\kappa}}{\lambda}} f(w_1 | x, w_0) f(x, w_0) dw_1 dw_0 dx
\end{aligned}$$

## 5. ILLUSTRATIVE EXAMPLES

### 5.1. Run-length probabilities if the unknown process variance has changed

$$\begin{aligned}
&= \int_0^\infty \int_{\frac{xLCL_\kappa}{\lambda}}^{\frac{xUCL_\kappa}{\lambda}} f(x, w_0) dw_0 dx - \int_0^\infty \int_{\frac{(x+\lambda w_0)LCL_{\kappa+1}}{\lambda}}^{\frac{(x+\lambda w_0)UCL_{\kappa+1}}{\lambda}} \int_{\frac{xLCL_\kappa}{\lambda}}^{\frac{xUCL_\kappa}{\lambda}} f(x, w_0, w_1) dw_1 dw_0 dx \\
&= \int_0^\infty \int_{\frac{xLCL_\kappa}{\lambda}}^{\frac{xUCL_\kappa}{\lambda}} f(x) f(w_0) dw_0 dx \\
&\quad - \int_0^\infty \int_{\frac{(x+\lambda w_0)LCL_{\kappa+1}}{\lambda}}^{\frac{(x+\lambda w_0)UCL_{\kappa+1}}{\lambda}} \int_{\frac{xLCL_\kappa}{\lambda}}^{\frac{xUCL_\kappa}{\lambda}} f(x) f(w_0) f(w_1) dw_1 dw_0 dx.
\end{aligned} \tag{5.18}$$

The conditional probability that the run-length is three, is:

$$\begin{aligned}
&\Pr(N = 3 | X = x) \\
&= \Pr(A_0 \cap A_1 \cap A_2^C | X = x) \\
&= \Pr(A_2^C | A_0 \cap A_1, X = x) \Pr(A_1 | A_0, X = x) \Pr(A_0 | X = x),
\end{aligned} \tag{5.19}$$

and from (5.12) and ((5.16))

$$\Pr(A_0 | X = x) = \int_{\frac{xLCL_\kappa}{\lambda}}^{\frac{xUCL_\kappa}{\lambda}} f(w_0 | x) dw_0 \tag{5.20}$$

$$\Pr(A_1 | A_0, X = x) = \int_{\frac{(x+\lambda w_0)LCL_{\kappa+1}}{\lambda}}^{\frac{(x+\lambda w_0)UCL_{\kappa+1}}{\lambda}} f(w_1 | x, w_0) dw_1. \tag{5.21}$$

Then, from (2.7),

$$\begin{aligned}
&\Pr(A_2^C | A_0 \cap A_1, X = x) \\
&= 1 - \Pr(A_2 | A_0 \cap A_1, X = x) \\
&= 1 - \Pr(LCL_{\kappa+2} < U_2 < UCL_{\kappa+2} | X = x, LCL_\kappa < U_0 < UCL_\kappa, LCL_{\kappa+1} < U_1 < UCL_{\kappa+1}) \\
&= 1 - \Pr\left(LCL_{\kappa+2} < \frac{\lambda W_2}{x + \lambda w_0 + \lambda w_1} < UCL_{\kappa+2} | X = x, W_0, W_1\right) \\
&= 1 - \Pr\left(\frac{(x + \lambda w_0 + \lambda w_1)LCL_{\kappa+2}}{\lambda} < W_2 < \frac{(x + \lambda w_0 + \lambda w_1)UCL_{\kappa+2}}{\lambda} | X = x, W_0, W_1\right) \\
&= 1 - \int_{\frac{(x+\lambda w_0+\lambda w_1)LCL_{\kappa+2}}{\lambda}}^{\frac{(x+\lambda w_0+\lambda w_1)UCL_{\kappa+2}}{\lambda}} f(w_2 | x, w_0, w_1) dw_2.
\end{aligned} \tag{5.22}$$

## 5. ILLUSTRATIVE EXAMPLES

### 5.1. Run-length probabilities if the unknown process variance has changed

Substituting (5.20), (5.21) and (5.22) in (5.19), the conditional probability that the run-length is three, is

$$\begin{aligned}
& \Pr(N = 3 | X = x) \\
&= \left[ 1 - \int \frac{\frac{(x+\lambda w_0+\lambda w_1)UCL_{\kappa+2}}{\lambda}}{\frac{(x+\lambda w_0+\lambda w_1)LCL_{\kappa+2}}{\lambda}} f(w_2 | x, w_0, w_1) dw_2 \right] \left[ \int \frac{\frac{(x+\lambda w_0)UCL_{\kappa+1}}{\lambda}}{\frac{(x+\lambda w_0)LCL_{\kappa+1}}{\lambda}} f(w_1 | x, w_0) dw_1 \right] \\
&\quad \times \left[ \int \frac{\frac{xUCL_{\kappa}}{\lambda}}{\frac{xLCL_{\kappa}}{\lambda}} f(w_0 | x) dw_0 \right] \\
&= \int \frac{\frac{(x+\lambda w_0)UCL_{\kappa+1}}{\lambda}}{\frac{(x+\lambda w_0)LCL_{\kappa+1}}{\lambda}} f(w_1 | x, w_0) dw_1 \int \frac{\frac{xUCL_{\kappa}}{\lambda}}{\frac{xLCL_{\kappa}}{\lambda}} f(w_0 | x) dw_0 \\
&\quad - \left[ \int \frac{\frac{(x+\lambda w_0+\lambda w_1)UCL_{\kappa+2}}{\lambda}}{\frac{(x+\lambda w_0+\lambda w_1)LCL_{\kappa+2}}{\lambda}} f(w_2 | x, w_0, w_1) dw_2 \right. \\
&\quad \left. \times \int \frac{\frac{(x+\lambda w_0)UCL_{\kappa+1}}{\lambda}}{\frac{(x+\lambda w_0)LCL_{\kappa+1}}{\lambda}} f(w_1 | x, w_0) dw_1 \int \frac{\frac{xUCL_{\kappa}}{\lambda}}{\frac{xLCL_{\kappa}}{\lambda}} f(w_0 | x) dw_0 \right]. \tag{5.23}
\end{aligned}$$

Using (5.23), the unconditional probability that the run-length is three, is:

$$\begin{aligned}
& \Pr(N = 3) \\
&= E_X [\Pr(N = 3 | X)] \\
&= \int_0^{\infty} \Pr(N = 3 | X = x) f(x) dx \\
&= \int_0^{\infty} \left[ \int \frac{\frac{(x+\lambda w_0)UCL_{\kappa+1}}{\lambda}}{\frac{(x+\lambda w_0)LCL_{\kappa+1}}{\lambda}} f(w_1 | x, w_0) dw_1 \int \frac{\frac{xUCL_{\kappa}}{\lambda}}{\frac{xLCL_{\kappa}}{\lambda}} f(w_0 | x) dw_0 \right. \\
&\quad - \left( \int \frac{\frac{(x+\lambda w_0+\lambda w_1)UCL_{\kappa+2}}{\lambda}}{\frac{(x+\lambda w_0+\lambda w_1)LCL_{\kappa+2}}{\lambda}} f(w_2 | x, w_0, w_1) dw_2 \int \frac{\frac{(x+\lambda w_0)UCL_{\kappa+1}}{\lambda}}{\frac{(x+\lambda w_0)LCL_{\kappa+1}}{\lambda}} f(w_1 | x, w_0) dw_1 \right. \\
&\quad \left. \left. \times \int \frac{\frac{xUCL_{\kappa}}{\lambda}}{\frac{xLCL_{\kappa}}{\lambda}} f(w_0 | x) dw_0 \right) \right] f(x) dx
\end{aligned}$$

## 5. ILLUSTRATIVE EXAMPLES

### 5.1. Run-length probabilities if the unknown process variance has changed

$$\begin{aligned}
&= \int_0^\infty \int_{\frac{(x+\lambda w_0)LCL_{\kappa+1}}{\lambda}}^{\frac{(x+\lambda w_0)UCL_{\kappa+1}}{\lambda}} f(w_1 | x, w_0) dw_1 \int_{\frac{xLCL_{\kappa}}{\lambda}}^{\frac{xUCL_{\kappa}}{\lambda}} f(w_0 | x) dw_0 f(x) dx \\
&\quad - \left[ \int_0^\infty \int_{\frac{(x+\lambda w_0+\lambda w_1)LCL_{\kappa+2}}{\lambda}}^{\frac{(x+\lambda w_0+\lambda w_1)UCL_{\kappa+2}}{\lambda}} f(w_2 | x, w_0, w_1) dw_2 \int_{\frac{(x+\lambda w_0)LCL_{\kappa+1}}{\lambda}}^{\frac{(x+\lambda w_0)UCL_{\kappa+1}}{\lambda}} f(w_1 | x, w_0) dw_1 \right. \\
&\quad \left. \times \int_{\frac{xLCL_{\kappa}}{\lambda}}^{\frac{xUCL_{\kappa}}{\lambda}} f(w_0 | x) dw_0 f(x) dx \right] \\
&= \int_0^\infty \int_{\frac{(x+\lambda w_0)LCL_{\kappa+1}}{\lambda}}^{\frac{(x+\lambda w_0)UCL_{\kappa+1}}{\lambda}} f(w_1 | x, w_0) dw_1 \int_{\frac{xLCL_{\kappa}}{\lambda}}^{\frac{xUCL_{\kappa}}{\lambda}} f(x, w_0) dw_0 dx \\
&\quad - \left[ \int_0^\infty \int_{\frac{(x+\lambda w_0+\lambda w_1)LCL_{\kappa+2}}{\lambda}}^{\frac{(x+\lambda w_0+\lambda w_1)UCL_{\kappa+2}}{\lambda}} f(w_2 | x, w_0, w_1) dw_2 \int_{\frac{(x+\lambda w_0)LCL_{\kappa+1}}{\lambda}}^{\frac{(x+\lambda w_0)UCL_{\kappa+1}}{\lambda}} f(w_1 | x, w_0) dw_1 \right. \\
&\quad \left. \times \int_{\frac{xLCL_{\kappa}}{\lambda}}^{\frac{xUCL_{\kappa}}{\lambda}} f(x, w_0) dw_0 dx \right] \\
&= \int_0^\infty \int_{\frac{(x+\lambda w_0)LCL_{\kappa+1}}{\lambda}}^{\frac{(x+\lambda w_0)UCL_{\kappa+1}}{\lambda}} \int_{\frac{xLCL_{\kappa}}{\lambda}}^{\frac{xUCL_{\kappa}}{\lambda}} f(w_1 | x, w_0) f(x, w_0) dw_1 dw_0 dx \\
&\quad - \left[ \int_0^\infty \int_{\frac{(x+\lambda w_0+\lambda w_1)LCL_{\kappa+2}}{\lambda}}^{\frac{(x+\lambda w_0+\lambda w_1)UCL_{\kappa+2}}{\lambda}} \int_{\frac{(x+\lambda w_0)LCL_{\kappa+1}}{\lambda}}^{\frac{(x+\lambda w_0)UCL_{\kappa+1}}{\lambda}} \int_{\frac{xLCL_{\kappa}}{\lambda}}^{\frac{xUCL_{\kappa}}{\lambda}} f(w_2 | x, w_0, w_1) f(w_1 | x, w_0) \right. \\
&\quad \left. \times f(x, w_0) dw_2 dw_1 dw_0 dx \right] \\
&= \int_0^\infty \int_{\frac{(x+\lambda w_0)LCL_{\kappa+1}}{\lambda}}^{\frac{(x+\lambda w_0)UCL_{\kappa+1}}{\lambda}} \int_{\frac{xLCL_{\kappa}}{\lambda}}^{\frac{xUCL_{\kappa}}{\lambda}} f(x, w_0, w_1) dw_1 dw_0 dx \\
&\quad - \left[ \int_0^\infty \int_{\frac{(x+\lambda w_0+\lambda w_1)LCL_{\kappa+2}}{\lambda}}^{\frac{(x+\lambda w_0+\lambda w_1)UCL_{\kappa+2}}{\lambda}} \int_{\frac{(x+\lambda w_0)LCL_{\kappa+1}}{\lambda}}^{\frac{(x+\lambda w_0)UCL_{\kappa+1}}{\lambda}} \int_{\frac{xLCL_{\kappa}}{\lambda}}^{\frac{xUCL_{\kappa}}{\lambda}} f(w_2 | x, w_0, w_1) \right. \\
&\quad \left. \times f(x, w_0, w_1) dw_2 dw_1 dw_0 dx \right] \\
&= \int_0^\infty \int_{\frac{(x+\lambda w_0)LCL_{\kappa+1}}{\lambda}}^{\frac{(x+\lambda w_0)UCL_{\kappa+1}}{\lambda}} \int_{\frac{xLCL_{\kappa}}{\lambda}}^{\frac{xUCL_{\kappa}}{\lambda}} f(x, w_0, w_1) dw_1 dw_0 dx \\
&\quad - \int_0^\infty \int_{\frac{(x+\lambda w_0+\lambda w_1)LCL_{\kappa+2}}{\lambda}}^{\frac{(x+\lambda w_0+\lambda w_1)UCL_{\kappa+2}}{\lambda}} \int_{\frac{(x+\lambda w_0)LCL_{\kappa+1}}{\lambda}}^{\frac{(x+\lambda w_0)UCL_{\kappa+1}}{\lambda}} \int_{\frac{xLCL_{\kappa}}{\lambda}}^{\frac{xUCL_{\kappa}}{\lambda}} f(x, w_0, w_1, w_2) dw_2 dw_1 dw_0 dx \\
&= \int_0^\infty \int_{\frac{(x+\lambda w_0)LCL_{\kappa+1}}{\lambda}}^{\frac{(x+\lambda w_0)UCL_{\kappa+1}}{\lambda}} \int_{\frac{xLCL_{\kappa}}{\lambda}}^{\frac{xUCL_{\kappa}}{\lambda}} f(x) f(w_0) f(w_1) dw_1 dw_0 dx \tag{5.24} \\
&\quad - \int_0^\infty \int_{\frac{(x+\lambda w_0+\lambda w_1)LCL_{\kappa+2}}{\lambda}}^{\frac{(x+\lambda w_0+\lambda w_1)UCL_{\kappa+2}}{\lambda}} \int_{\frac{(x+\lambda w_0)LCL_{\kappa+1}}{\lambda}}^{\frac{(x+\lambda w_0)UCL_{\kappa+1}}{\lambda}} \int_{\frac{xLCL_{\kappa}}{\lambda}}^{\frac{xUCL_{\kappa}}{\lambda}} f(x) f(w_0) f(w_1) f(w_2) dw_2 dw_1 dw_0 dx.
\end{aligned}$$

## 5. ILLUSTRATIVE EXAMPLES

### 5.2. Run-length probabilities if the unknown process variance and known process mean have changed

---

For  $N$  of higher orders, the conditional and unconditional probabilities can be determined in a similar way.

Continuing with the example (where  $\lambda = 2$ ,  $v_j = 4$ ,  $\kappa = 11$ ,  $a = 40$ ), the corresponding approximate run-length probabilities are (see (5.13), (5.18) and (5.24)):

$$\Pr(N = 1) = 1 - \int_0^\infty \int_{\frac{0.0025837x}{2}}^{\frac{0.5444577x}{2}} f(x) f(w_0) dw_0 dx = 0.043129,$$

$$\begin{aligned} \Pr(N = 2) &= \int_0^\infty \int_{\frac{0.5444577x}{2}}^{\frac{0.5444577x}{2}} f(x) f(w_0) dw_0 dx \\ &\quad - \int_0^\infty \int_{\frac{0.5444577x}{2}}^{\frac{0.5444577x}{2}} \int_{\frac{0.4858039(x+2w_0)}{2}}^{\frac{0.0023536(x+2w_0)}{2}} f(x) f(w_0) f(w_1) dw_1 dw_0 dx \\ &= 0.956871 - 0.924702 = 0.032169, \end{aligned}$$

$$\Pr(N = 3)$$

$$\begin{aligned} &= \int_0^\infty \int_{\frac{0.5444577x}{2}}^{\frac{0.5444577x}{2}} \int_{\frac{0.4858039(x+2w_0)}{2}}^{\frac{0.0023536(x+2w_0)}{2}} f(x) f(w_0) f(w_1) dw_1 dw_0 dx \\ &\quad - \int_0^\infty \int_{\frac{0.5444577x}{2}}^{\frac{0.5444577x}{2}} \int_{\frac{0.4858039(x+2w_0)}{2}}^{\frac{0.0023536(x+2w_0)}{2}} \int_{\frac{0.0021612(x+2w_0+2w_1)}{2}}^{\frac{0.4384660(x+2w_0+2w_1)}{2}} f(x) f(w_0) f(w_1) f(w_2) dw_2 dw_1 dw_0 dx \\ &= 0.924702 - 0.899646 = 0.025056. \end{aligned}$$

Take note that this method obtains exactly the same run-length probabilities as the method using the derived pdfs discussed in Section 5.1.1.

For this method there is already a warning that the numerical integration converges too slowly when calculating  $\Pr(N = 3)$ . Therefore, for both exact methods (see also Section 5.1.1) there are computational difficulties with determining the higher order integrals.

## 5.2 Run-length probabilities if the unknown process variance and known process mean have changed

This section continues with the practical example (based on simulated data) mentioned in the introduction of Section 5.1 where  $\lambda = 2$ ,  $v_j = n = 4$ ,  $\kappa = 11$ ,  $a = 40$ . It will be assumed that the mean and variance changed simultaneously between sample number ten and eleven, therefore  $\delta_a = 0$ .

## 5. ILLUSTRATIVE EXAMPLES

### 5.3. Run-length probabilities in the matrix environment

The run-length probabilities can again be calculated using (5.3), (5.6) together with the pdf of the noncentral generalised multivariate beta type II distribution given in (3.28). The focus of this section is to determine the effect of the different parameters of the noncentral generalised multivariate beta type II distribution on the probability to detect the shift in the variance immediately, i.e.  $\Pr(N = 1) = 1 - \int_{LCL_\kappa}^{UCL_\kappa} f(u_0) du_0$  with  $f(u_0)$  given in (3.20). The software package Mathematica was used to calculate the probabilities by using the summation form of the Humbert function (see (B.13)) in (3.20).

Table 5.1 summarises the effect of the different parameters on the probability to detect the shift in the variance immediately with reference case  $\lambda = 2$ ,  $v_j = n = 4$ ,  $\kappa = 11$ ,  $a = 40$ ,  $\delta_a = 0$  and  $\delta_0 = 5$ .

**Table 5.1** Run-length probabilities for different parameter values

| Role of                                 | $\delta_a$ | $\delta_0$ | $n$ | $\kappa$ | $\lambda$ | $\Pr(N = 1)$ | Comment / Interpretation  |
|---|------------|------------|-----|----------|-----------|--------------|---|
| $\lambda = \frac{\sigma_1^2}{\sigma^2}$ | 0          | 5          | 4   | 11       | 0.5       | 0.015217     | The larger the step shift, the greater the probability.   |
|   |            |            |     |          | 1         | 0.053953     |   |
|   |            |            |     |          | 2         | 0.330066     |   |
| $\kappa$                                | 0          | 5          | 4   | 3        | 2         | 0.092279     | The more historical samples available before the shift took place, the greater the probability. |
|   |            |            |     | 5        |           | 0.203600     |   |
|   |            |            |     | 11       |           | 0.330066     |   |
| $n$                                     | 0          | 5          | 1   | 11       | 2         | 0.260396     | The larger the sample size, the greater the probability.  |
|   |            |            | 4   |          |           | 0.330066     |   |
|   |            |            | 10  |          |           | 0.382749     |   |
| $\delta_0$                              | 0          | 0          | 4   | 11       | 2         | 0.043129     | The larger $\delta_0$ , (i.e. the relative change in the mean), the greater the probability.    |
|   |            | 2          |     |          |           | 0.140078     |   |
|   |            | 5          |     |          |           | 0.330066     |   |

### 5.3 Run-length probabilities in the matrix environment

This section proposes a method to address the calculation of run-length probabilities in the matrix set-up. Percentage points are calculated as an illustration for the probability to detect the shift immediately (i.e. run-length of one).

The probability of detecting a shift immediately, in other words, the probability of a run-length of one, is the probability that the charting statistic will plot on or outside the control limits upon collecting the first sample after the change in the variance (see (5.2)). In the matrix environment  $|\mathbf{U}_0|$  is of interest as a test statistic for testing the null



## 5. ILLUSTRATIVE EXAMPLES

### 5.3. Run-length probabilities in the matrix environment

---

hypothesis at time  $\kappa$  that the covariance matrix structure did not change, i.e. the process is in-control. Therefore, if the statistic  $|\mathbf{U}_0|$  exceeds a critical value (say  $c_0$ ) it will be an indication that the covariance matrix structure changed and that the process is declared out-of-control. Note that this proposed method deviates from the univariate case where a two sided hypothesis is considered (see (5.2)). Thus, once the covariance matrix structure changes, the probability to detect this change immediately, in other words, the probability of a run-length of one is

$$\Pr(N = 1) \equiv P [|\mathbf{U}_0| \geq c_0]. \quad (5.25)$$

Take note that  $c_0$  indicates an upper critical value and not a control limit as before (see (5.2)). If  $q = 1$  then  $c_0$  is comparable to the *UCL* of a one-sided hypothesis in the univariate case. Also, like before, this is essentially a conditional probability.

In a similar way the run-length of two implies that even though the covariance matrix changed, this change is not detected using the control chart at time  $\kappa$ , but that the chart only signals that the process out-of-control at time  $\kappa + 1$ . Therefore

$$\begin{aligned} \Pr(N = 2) &\equiv \Pr [|\mathbf{U}_0| < c_0, |\mathbf{U}_1| \geq c_1] \\ &= \Pr [|\mathbf{U}_0| < c_0] - \Pr [|\mathbf{U}_0| < c_0, |\mathbf{U}_1| < c_1]. \end{aligned} \quad (5.26)$$

From (5.26) it is evident that the joint pdf of  $(|\mathbf{U}_0|, |\mathbf{U}_1|)$  is needed to calculate the probability of a run-length of two. This joint pdf was derived in Theorem 4.9, but a closed form expression could not be obtained. Another possibility is to assume independence of the statistics  $|\mathbf{U}_0|$  and  $|\mathbf{U}_1|$  (see discussion in Section 5.1.3), then the approximate run-length probability is

$$\Pr(N = 2) \approx \Pr [|\mathbf{U}_0| < c_0] - \Pr [|\mathbf{U}_0| < c_0] \Pr [|\mathbf{U}_1| < c_1].$$

Even in the case of the above approximation one still encounters computational challenges, since the pdf of  $|\mathbf{U}_1|$  (see (4.31), (4.77)) contains a zonal polynomial. This computational aspect needs further investigation and is not in the scope of this study.

In the example that follows percentage points will be calculated for a run-length of one for the scenario where the covariance matrix changes with a scale factor from  $\Sigma$  to  $\lambda\Sigma$ . Only the simplest two cases with  $q = 1, 2$  (i.e. a univariate and bimatrix process) is considered. From (5.25)

$$\Pr(N = 1) = 1 - F_{|\mathbf{U}_0|}(c_0),$$

## 5. ILLUSTRATIVE EXAMPLES

### 5.3. Run-length probabilities in the matrix environment

---

where  $F_{|\mathbf{U}_0|}(\cdot)$  is the CDF of  $|\mathbf{U}_0|$  given in (4.30).

From (4.30) for  $q = 1$  follows

$$F_{|\mathbf{U}_0|}(c_0) = \frac{1}{\Gamma\left(\frac{1}{2}v_1\right)\Gamma\left(\frac{1}{2}v_2\right)} G_{2,2}^{1,2} \left( \lambda^{-1} c_0 \middle| \begin{matrix} 1, -\frac{1}{2}v_1+1 \\ \frac{1}{2}v_2, 0 \end{matrix} \right). \quad (5.27)$$

Using (4.30) and (C.35) for  $q = 2$ , follows

$$F_{|\mathbf{U}_0|}(c_0) = \frac{1}{\Gamma\left(\frac{1}{2}v_1\right)\Gamma\left(\frac{1}{2}v_1 - \frac{1}{2}\right)\Gamma\left(\frac{1}{2}v_2\right)\Gamma\left(\frac{1}{2}v_2 - \frac{1}{2}\right)} G_{3,3}^{2,3} \left( \lambda^{-2} c_0 \middle| \begin{matrix} 1, -\frac{1}{2}v_1+1, -\frac{1}{2}v_1+\frac{3}{2} \\ \frac{1}{2}v_2, \frac{1}{2}v_2-\frac{1}{2}, 0 \end{matrix} \right).$$

The percentage points  $c_0$  of  $|\mathbf{U}_0|$  are obtained numerically by solving the equation

$$F_{|\mathbf{U}_0|}(c_0) = \int_0^{c_0} f(|\mathbf{U}_0|) d|\mathbf{U}_0| = 1 - \gamma. \quad (5.28)$$

Evidently, this involves computation of the Meijer's G-function and routines are widely available. The built-in routines of the package Mathematica was used.

Table 5.2 provides the numerical values of  $c_0$  for different values of  $\lambda$  and  $\gamma$  for the case if  $q = 1$  (univariate) and  $q = 2$  (bimatrix). In this example samples of equal size of four is collected at each point in time, i.e.  $v_2 = n = 4$ . It is assumed that the covariance matrix changes with a scale factor  $\lambda$ , between samples  $\kappa - 1$  and  $\kappa$  where  $\kappa = 3$ , therefore  $v_1 = (\kappa - 1) \times n = 8$ . The value of  $\kappa$  is different from the value used in the other examples, due to computational resources.

**Table 5.2** The upper percentage points  $c_0$

| $\lambda$ | $q$ | $\gamma = 0.01$ | $\gamma = 0.025$ | $\gamma = 0.05$ | $\gamma = 0.1$ |
|-----------|-----|-----------------|------------------|-----------------|----------------|
| 2         | 1   | 7.00608         | 5.05263          | 3.83785         | 2.80643        |
| 1         | 1   | 3.50304         | 2.52632          | 1.91893         | 1.40321        |
| 0.5       | 1   | 1.75152         | 1.26316          | 0.95946         | 0.70161        |
| 2         | 2   | 7.29343         | 4.50351          | 2.97902         | 1.80558        |
| 1         | 2   | 3.64671         | 2.25176          | 1.48951         | 0.91746        |
| 0.5       | 2   | 1.82336         | 1.12588          | 0.74475         | 0.46006        |

Similar tabulations can be obtained for other values of the parameters, as well as the lower percentiles.

**Remark 5.3** *The upper percentage points  $c_0$  in the simple case when  $q = 1$  can be related to the control limits (see (5.4)). In the above example a one-sided test was considered, i.e. the chart would signal that the process is out-of-control if  $|\mathbf{U}_0| > c_0$ . Remark 5.2 mentioned that the desirable FAR of a two-sided control chart is 0.0027. Substituting  $\gamma = \frac{0.0027}{2} = 0.00135$  in (5.28) with  $q = 1$  and  $\lambda = 1$ , gives  $c_0 = 6.58684$ . This value corresponds to the UCL in (5.4) when i.e.*

$$UCL_{\kappa=3} = \frac{F_{n_{\kappa}, \sum_{i=1}^{\kappa-1} n_i}^{-1} [\Phi(3)]}{\frac{\sum_{i=1}^{\kappa-1} n_i}{n_{\kappa}}} = \frac{F_{4,8}^{-1} [\Phi(3)]}{\frac{8}{4}} = 6.58684.$$

## 5.4 Conclusion

The computational aspect of the run-length (i.e. evaluating multiple integral expressions) was illustrated for the scenario when monitoring the variance when the underlying process distribution is normal. The use of the exact expressions for the pdf (2.8) was illustrated. Further the effect of the parameters on the probability to detect the shift in the variance immediately for the scenario when the known process mean has changed as well was demonstrated. The chapter was concluded with proposing a method to address the run-length concept and some percentage points were calculated.

# Chapter 6

## Conclusions

In this thesis a generalised multivariate beta type II distribution as well as the noncentral and bimatrix variate counterparts with positive domain were developed; these distributions emanated from a sequential process with the normal distribution and multivariate normal distribution as the underlying process distributions.

Figure 6.1 provides a visual representation of the framework of this thesis. The green panel shows the process distribution from which the samples are collected and the parameter being monitored. The red panel indicates the change in the process parameters. The new distributions that were derived in this thesis is given in the yellow panel. Relations between the distributions are indicated in the blue panel. At the bottom of the figure the chapter is indicated where each situation was addressed.

To summarise:

- In Chapter 2 the generalised multivariate beta type II distribution was derived; this distribution stems from the scenario where the variance of a normal random variable is monitored assuming that the mean remains unchanged.
- Chapter 3 generalised the ideas of Chapter 2. The focus of Chapter 3 was on the scenario where the variance of a normal random variable is monitored and it is assumed that the mean also encounters a sustained shift. This introduces the noncentral generalised multivariate beta type II distribution. It was shown that by setting the noncentrality parameters equal to zero this distribution will reduce to the generalised multivariate beta type II distribution of Chapter 2.
- In Chapter 4 the generalised bimatrix variate beta type II distribution was proposed. Two cases were considered: (i) the special case where the covariance structure changes with a scale factor, i.e. from  $\Sigma$  to  $\lambda\Sigma$  and, (ii) the more general case

where the complete covariance structure change from  $\Sigma$  to  $\Sigma_1$ . This was achieved using newly derived results based on the principles of Muirhead (1982) [32], p.248 and Davis (1979) [7]. The latter case simplifies to the generalised multivariate beta type II distribution of Chapter 2 for  $q = 1$ .

- In Chapter 5 an example demonstrated the use of the exact expressions of the pdfs in calculating the probabilities of run-lengths, the measure to gain insight into the performance of a Shewhart-type Q-chart.

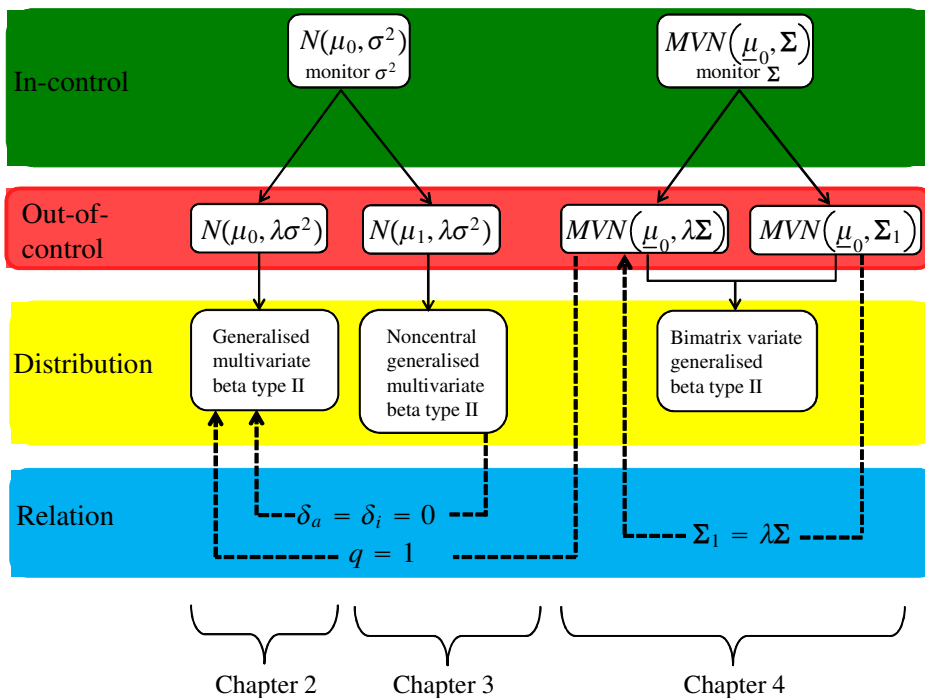

**Figure 6.1.** Summary of the framework of this thesis

The following concluding remarks prevail:

The generalised multivariate beta type II distribution and the marginal distributions, as well as the noncentral and the bimatrix variate cases contribute two-fold, namely: (i) as new developments in the distribution theory field and (ii) for the first time the exact probabilities of Q-charting statistics plotting inside or outside the control limits can be calculated, and it is not restricted to the existing methods known in the statistical process environment, e.g simulation.

Areas for further research include, but are not limited to:

- An extension of the scenario in Chapter 2 where the process variance is monitored but instead of the single shift in the process variance between samples  $\kappa - 1$  and  $\kappa$ , multiple shifts will occur from sample  $\kappa - 1$  onwards.

## 6. CONCLUSIONS

---

- Studying the distributions of the Q-charting statistics when monitoring a process for mean shifts when the observations are sampled from a normal distribution.
- Further exploring the statistical properties of the newly derived distributions and their contribution in distribution theory field.
- Supposing that the covariance structure of  $q$  attributes of the items of a single process are monitored simultaneously where the samples are independent, having been collected from a multivariate normal distribution with known mean vector  $(\underline{\mu}_0)$  and unknown covariance matrix  $(\Sigma : q \times q)$ , denoted as  $MVN(\underline{\mu}_0, \Sigma)$  :
  - (i) The reader may be interested in more than two successive time periods immediately after the change in the covariance structure occurred, which will lead to new matrix variate Dirichlet type II distributions;
  - (ii) There may be a change in the known mean vector, similarly as in Chapter 3 with the normal process distribution. This will result in the noncentral bimatrix variate beta type II distribution.

In conclusion, with a sequential process monitoring scheme as the genesis, this study contributed to the distribution field by proposing new generalised multivariate / univariate / bivariate / bimatrix variate beta type II distributions that may serve as alternative to the existing models.



# APPENDICES

## A. Abbreviations and notation

|                     |   |
|---------------------|---|
| CDF                 | Cumulative distribution function  |
| $CL$                | Centerline  |
| CUSUM               | Cumulative sum chart  |
| EWMA                | Exponentially weighted moving average chart                                   |
| $FAR$               | False alarm rate  |
| $LCL$               | Lower control limit   |
| pdf                 | Probability density function  |
| SPC                 | Statistical Process Control   |
| $UCL$               | Upper control limit   |
| $\stackrel{d}{=}$   | Equal in distribution   |
| $Y_{ik}$            | Observation $k$ from sample $i$   |
| $n_i$               | Size of sample $i$  |
| $\kappa$            | The first time period following the shift in the process variance             |
| $\lambda$           | Unknown size of the shift in the variance                                     |
| $d$                 | The first time period following the shift in the known process mean           |
| $\mu_0$             | Known process mean  |
| $\mu_1$             | Known process mean after the shift in the mean                                |
| $\sigma^2$          | Unknown process variance before the variance encountered a shift              |
| $\sigma_1^2$        | Unknown process variance after the variance encountered a shift               |
| $S_i^2$             | The variance of the $i^{th}$ sample   |
| $S_r^{2pooled}$     | The pooled sample variance of all measurements up to and including sample $r$ |
| $N$                 | Run-length random variable  |
| $\mathbf{Y}^{(i)}$  | Matrix of observations for time period $i$                                    |
| $\underline{\mu}_0$ | Known mean vector   |
| $\Sigma$            | Unknown process covariance matrix before the covariance encountered a shift   |
| $\Sigma_1$          | Unknown process covariance matrix after the covariance encountered a shift    |
| $\mathbf{S}_i$      | Sample covariance matrix at time $i$  |



|  |  |
|--|--|
| $\mathbf{A} > \mathbf{0}$                              | $\mathbf{A}$ is a positive definite symmetric matrix   |
| $\mathbf{A}^{\frac{1}{2}}$                             | Unique positive definite square root of $\mathbf{A}$   |
| $ \mathbf{A} $   | Determinant of the square matrix $\mathbf{A}$  |
| $\ \mathbf{A}\ $                                       | The maximum of the absolute values of the characteristic roots of $\mathbf{A}$                         |
| $\mathbf{A}^{-1}$                                      | Inverse of a square matrix $\mathbf{A}$  |
| $\mathbf{A}'$  | Transpose of matrix $\mathbf{A}$   |
| $tr(\mathbf{A})$                                       | Trace of the square matrix $\mathbf{A}$  |
| $\text{etr}(\mathbf{A})$                               | $\exp(tr(\mathbf{A}))$ if $\mathbf{A}$ is a square matrix  |
| $J(\mathbf{X} \rightarrow f(\mathbf{X}))$              | The Jacobian of the matrix transformation $f$  |
| $\Gamma(\cdot)$  | Gamma function   |
| $\Gamma_q(\cdot)$                                      | Multivariate gamma function  |
| $\Gamma_q(\cdot, \tau)$                                | Generalised gamma function of weight $\tau$  |
| $(\alpha)_t$   | Pochhammer coefficient   |
| $(\alpha)_\tau$  | Generalised hypergeometric coefficient   |
| $B(\alpha, \beta)$                                     | Beta function  |
| $\beta_q(\alpha, \beta)$                               | Multivariate beta function   |
| $\beta_q(\alpha_1, \dots, \alpha_r; \beta)$            | Multivariate Dirichlet function  |
| ${}_rF_s(\cdot)$                                       | Hypergeometric series with $r$ upper parameters and $s$ lower parameters                               |
| $G_{r,s}^{m,n}(\cdot)$                                 | Meijer's G-function  |
| $H_{r,s}^{m,n}(\cdot)$                                 | Fox's H-function   |
| $\Psi$   | Confluent hypergeometric function  |
| $\Psi_2^{(s)}[\alpha; \beta_1, \dots, \beta_s; \cdot]$ | Confluent hypergeometric function in $s$ variables   |
| $\Psi_2[\alpha; \beta; \cdot]$                         | Humbert's confluent hypergeometric function  |
| $C_\tau(\cdot)$  | Zonal polynomial   |
| $M_f(\cdot)$   | Mellin transform   |
| $N(\mu, \sigma^2)$                                     | Normal distribution with mean $\mu$ and variance $\sigma^2$  |
| $\Phi(\cdot)$  | CDF of standard normal distribution  |
| $\Phi^{-1}(\cdot)$                                     | Inverse of the CDF of standard normal distribution   |
| $F(v_1, v_2)$  | $F$ distribution with $v_1$ and $v_2$ degrees of freedom   |
| $F_{v_1, v_2}(\cdot)$                                  | CDF of $F(v_1, v_2)$ distribution  |
| $F_{v_1, v_2}^{-1}(\cdot)$                             | Inverse of the CDF of $F(v_1, v_2)$ distribution   |
| $\chi^2(v)$  | Chi-squared distribution with $v$ degrees of freedom   |
| $\chi_{\delta_v}^{\prime 2}(v)$                        | Noncentral chi-squared distribution with $v$ degrees of freedom and noncentrality parameter $\delta_v$ |

|                                |  |
|--------------------------------|--|
| $Beta^{II}(\alpha, \beta)$     | Beta type II distribution with parameters $\alpha$ and $\beta$                                     |
| $MVN(\underline{\mu}, \Sigma)$ | Multivariate normal distribution with mean vector $\underline{\mu}$ and covariance matrix $\Sigma$ |
| $W_q(v, \Sigma)$               | Wishart distribution with parameters $v$ and $\Sigma$  |
| $B_q^{II}(\alpha, \beta)$      | Matrix variate beta type II distribution with parameters $\alpha$ and $\beta$                      |

## B. Scalar special functions and theory

**Result 1** (*Gradshteyn and Ryzhik, 2007 [11], p.892; p.897*)

The gamma function, denoted  $\Gamma(\alpha)$ , is defined as

$$\Gamma(\alpha) = \int_0^{\infty} e^{-t} t^{\alpha-1} dt, \quad (\text{B.1})$$

where  $\text{Re}(\alpha) > 0$ .

**Result 2** (*Gradshteyn and Ryzhik, 2007 [11], p.908; p.909*)

The beta function, denoted  $B(\alpha, \beta)$ , is defined as

$$B(\alpha, \beta) = \int_0^{\infty} x^{\alpha-1} (1+x)^{-(\alpha+\beta)} dx \quad (\text{B.2})$$

$$B(\alpha, \beta) = \frac{\Gamma(\alpha)\Gamma(\beta)}{\Gamma(\alpha+\beta)}, \quad (\text{B.3})$$

where  $\text{Re}(\alpha) > 0$ ,  $\text{Re}(\beta) > 0$  and  $\Gamma(\cdot)$  is the gamma function.

**Result 3** (*Mathai, 1993 [29], p.96*)

The Pochhammer coefficient is defined as

$$(\alpha)_j = \alpha(\alpha+1)\dots(\alpha+j-1) = \frac{\Gamma(\alpha+j)}{\Gamma(\alpha)}, \quad (\text{B.4})$$

where  $j = 1, 2, \dots$ ,  $(\alpha)_0 = 1$ ,  $\alpha \neq 0$ ,  $\text{Re}(\alpha) > 0$ ,  $\text{Re}(\alpha+j) > 0$  and  $\Gamma(\cdot)$  is the gamma function.

**Result 4** (*Mathai, 1993 [29], p.96*)

The hypergeometric series with  $r$  upper parameters and  $s$  lower parameters is defined as

$${}_rF_s(\alpha_1, \dots, \alpha_r; \beta_1, \dots, \beta_s; x) = \sum_{j=0}^{\infty} \frac{(\alpha_1)_j \dots (\alpha_r)_j x^j}{(\beta_1)_j \dots (\beta_s)_j j!}, \quad (\text{B.5})$$

where  $(\alpha)_j$  is the Pochhammer symbol.

The following holds for the series:

- (i) if any  $\alpha_i$ ,  $i = 1, \dots, r$ , is a negative integer or zero the series terminates and  ${}_rF_s$  becomes a polynomial in  $x$  provided none of  $\beta_k$ ,  $k = 1, \dots, s$ , is zero or a negative integer;
- (ii) if any  $\beta_k$ ,  $k = 1, \dots, s$ , is zero or a negative integer then the series is not defined unless there is an  $\alpha_i$ ,  $i = 1, \dots, r$ , such that  $(\alpha_i)_j$  becomes zero first. That is, suppose  $\alpha_i$  and  $\beta_k$  are two negative integers such that  $(\alpha_i)_\ell = 0$  for  $\ell \geq j$  and  $(\beta_k)_\ell = 0$  for  $\ell \geq n$ . Then in order for  ${}_rF_s$  to be defined  $j$  must be less than  $n$ ;
- (iii) the series converges for all  $x$  if  $r \leq s$  and for  $|x| < 1$  if  $r = s + 1$ ;
- (iv) the series diverges for all  $x$ ,  $x \neq 0$  for  $r > s + 1$ ;
- (v) if  $r = s + 1$  and  $|x| = 1$ , the series is absolutely convergent if  $\text{Re}(\gamma) < 0$  where  $\gamma = \sum_{j=1}^r \alpha_j - \sum_{j=1}^s \beta_j$ ; divergent if  $\text{Re}(\gamma) \geq 1$ ; and if  $r = s + 1$  and  $|x| = 1$ ,  $x \neq 1$ , the series is conditionally convergent if  $0 \leq \text{Re}(\gamma) < 1$ .

Some special cases of the hypergeometric series:

- 

$${}_0F_0(; x) = \sum_{j=0}^{\infty} \frac{x^j}{j!} = e^x \quad (\text{B.6})$$

- The binomial series

$${}_1F_0(\alpha; x) = \sum_{j=0}^{\infty} (\alpha)_j \frac{x^j}{j!} = (1-x)^{-\alpha} \quad , \quad |x| < 1 \quad (\text{B.7})$$

- 

$${}_0F_1(\beta; x) = \sum_{j=0}^{\infty} \frac{x^j}{(\beta)_j j!} \quad (\text{B.8})$$

- The confluent hypergeometric series or Kummer's hypergeometric series

$${}_1F_1(\alpha; \beta; x) = \sum_{j=0}^{\infty} \frac{(\alpha)_j x^j}{(\beta)_j j!} \quad (\text{B.9})$$

- The Gauss hypergeometric function

$${}_2F_1(\alpha, \beta; \varsigma; x) = \sum_{j=0}^{\infty} \frac{(\alpha)_j (\beta)_j x^j}{(\varsigma)_j j!} \quad , \quad |x| < 1. \quad (\text{B.10})$$

**Result 5** (*Sánchez et al., 2006 [43] p.1681*)

The confluent hypergeometric function  $\Psi_2^{(s)}$  in  $s$  variables  $x_1, \dots, x_s$  is defined as

$$\Psi_2^{(s)}[\alpha; \beta_1, \dots, \beta_s; x_1, \dots, x_s] = \sum_{j_1, \dots, j_s=0}^{\infty} \frac{(\alpha)_{j_1+\dots+j_s} x_1^{j_1} \dots x_s^{j_s}}{(\beta_1)_{j_1} \dots (\beta_s)_{j_s} j_1! \dots j_s!}, \quad (\text{B.11})$$

where the series expansion is valid for all  $x_i \in \mathbb{R}$ .  
 An alternative representation of  $\Psi_2^{(s)}$  is given by

$$\Psi_2^{(s)}[\alpha; \beta_1, \dots, \beta_s; x_1, \dots, x_s] = \frac{1}{\Gamma(\alpha)} \int_0^{\infty} e^{-t} t^{\alpha-1} \prod_{i=1}^s {}_0F_1(\beta_i; tx_i) dt. \quad (\text{B.12})$$

For  $s = 2$ ,  $\Psi_2^{(s)} = \Psi_2$  is the Humbert's confluent hypergeometric function of two variables:

$$\Psi_2[\alpha; \beta_1, \beta_2; x_1, x_2] = \sum_{j_1=0}^{\infty} \sum_{j_2=0}^{\infty} \frac{(\alpha)_{j_1+j_2} x_1^{j_1} x_2^{j_2}}{(\beta_1)_{j_1} (\beta_2)_{j_2} j_1! j_2!}. \quad (\text{B.13})$$

**Result 6** (*Mathai, 1993 [29], p.23*)

If  $f(x)$  is a real function which is single valued almost everywhere for  $x \geq 0$  and if the integral

$$\int_0^{\infty} x^{k-1} |f(x)| dx,$$

converges for some value of  $k$  then the Mellin transform of  $f(x)$  is defined as follows:

$$M_f(h) \equiv \int_0^{\infty} x^{h-1} f(x) dx, \quad (\text{B.14})$$

where  $M_f(h)$  is the Mellin transform of  $f$  with respect to the parameter  $h$  and  $h$  is a complex number. The inverse Mellin transform is given by the inverse integral

$$f(x) = \frac{1}{2\pi i} \int_{\omega-i\infty}^{\omega+i\infty} M_f(h) x^{-h} dh, \quad (\text{B.15})$$

where  $i = \sqrt{-1}$  and  $\omega$  is a real number in the strip of analyticity of  $M_f(h)$ .

**Result 7** (*Mathai, 1993 [29], p.60*)

Meijer's G-function with the parameters  $\alpha_1, \dots, \alpha_r$  and  $\beta_1, \dots, \beta_s$  is defined as

$$G_{r,s}^{m,n} \left( x \middle| \begin{matrix} \alpha_1, \dots, \alpha_r \\ \beta_1, \dots, \beta_s \end{matrix} \right) = \frac{1}{2\pi i} \int_L g(h) x^{-h} dh, \quad (\text{B.16})$$

where  $i = \sqrt{-1}$ ,  $L$  is a suitable contour,  $x \neq 0$ ,

$$g(h) = \frac{\prod_{j=1}^m \Gamma(\beta_j+h) \prod_{j=1}^n \Gamma(1-\alpha_j-h)}{\prod_{j=m+1}^s \Gamma(1-\beta_j-h) \prod_{j=n+1}^r \Gamma(\alpha_j+h)},$$

where  $m, n, r$  and  $s$  are integers with  $0 \leq n \leq r$  and  $0 \leq m \leq s$ .

The parameters  $\alpha_1, \dots, \alpha_r$  and  $\beta_1, \dots, \beta_s$  are complex numbers such that no pole of  $\Gamma(\beta_j + h)$ ,  $j = 1, \dots, m$  coincides with any pole of  $\Gamma(1 - \alpha_k - h)$ ,  $k = 1, \dots, n$ .

The empty product is interpreted as 0.

**Result 8** (*Mathai, 1993 [29], p.140*)

Fox's H-function is defined as

$$H_{r,s}^{m,n} \left( x \middle| \begin{matrix} (a_1, \alpha_1), \dots, (a_r, \alpha_r) \\ (b_1, \beta_1), \dots, (b_s, \beta_s) \end{matrix} \right) = \frac{1}{2\pi i} \int_C g(h) x^{-h} dh, \quad (\text{B.17})$$

where

$$g(h) = \frac{\prod_{j=1}^m \Gamma(b_j + \beta_j h) \prod_{j=1}^n \Gamma(1 - a_j - \alpha_j h)}{\prod_{j=m+1}^s \Gamma(1 - b_j - \beta_j h) \prod_{j=n+1}^r \Gamma(a_j + \alpha_j h)},$$

and where  $0 \leq m \leq s$ ,  $0 \leq n \leq r$ ,  $\alpha_j > 0$  for  $j = 1, 2, \dots, r$ ,  $\beta_j > 0$  for  $j = 1, 2, \dots, s$ , and  $a_j$  ( $j = 1, 2, \dots, r$ ) and  $b_j$  ( $j = 1, 2, \dots, s$ ) are complex numbers such that no pole of  $\Gamma(b_j + \beta_j h)$  for  $j = 1, 2, \dots, m$  coincides with any pole of  $\Gamma(1 - a_j - \alpha_j h)$  for  $j = 1, 2, \dots, n$ . Furthermore,  $C$  is a contour in the complex  $h$ -plane running from  $\omega - i\infty$  to  $\omega + i\infty$  for some real number  $\omega$ .

**Result 9** (*Gradshteyn and Ryzhik, 2007 [11], p.337*)

$$\int_0^{\infty} x^{\beta-1} e^{-\frac{x}{\alpha}} dx = \alpha^{\beta} \Gamma(\beta), \quad (\text{B.18})$$

for  $\alpha, \beta > 0$ .

**Result 10** (*Gradshteyn and Ryzhik, 2007 [11], p.315*)

$$\int_0^{\infty} \frac{x^{\alpha-1}}{(1 + \gamma x)^{\beta}} dx = \gamma^{-\alpha} B(\alpha, \beta - \alpha), \quad (\text{B.19})$$

for  $|\arg \gamma| < \pi$ ,  $\text{Re}(\beta) > \text{Re}(\alpha) > 0$  where  $B(\cdot, \cdot)$  is the beta function.

**Result 11** (*Gradshteyn and Ryzhik, 2007 [11], p.317*)

$$\int_0^{\infty} x^{\alpha-1} (1+x)^{\beta} (1+\gamma x)^c dx = B(\alpha, -c - \beta - \alpha) {}_2F_1(-c, \alpha; -c - \beta; 1 - \gamma), \quad (\text{B.20})$$

for  $|\arg \gamma| < \pi$ ,  $-\text{Re}(c + \beta) > \text{Re}(\alpha) > 0$  where  $B(\cdot, \cdot)$  is the beta function and  ${}_2F_1(\cdot)$  is the Gauss hypergeometric function.

**Result 12** (*Gradshteyn and Ryzhik, 2007 [11], p.347*)

$$\int_0^c x^{\beta-1} (c-x)^{\alpha-1} e^{\gamma x} dx = B(\alpha, \beta) c^{\alpha+\beta-1} {}_1F_1(\beta; \alpha + \beta; \gamma c), \quad (\text{B.21})$$

for  $\text{Re}(\alpha) > 0$  and  $\text{Re}(\beta) > 0$  where  $B(\cdot, \cdot)$  is the beta function and  ${}_1F_1(\cdot)$  is the confluent hypergeometric series.

**Result 13** (*Gradshteyn and Ryzhik, 2007 [11], p.815*)

$$\begin{aligned} \int_0^\infty x^{c-1} e^{-\gamma x} {}_rF_s(\alpha_1, \dots, \alpha_r; \beta_1, \dots, \beta_s; \varrho x) dx \\ = \Gamma(c) \gamma^{-c} {}_{r+1}F_s\left(\alpha_1, \dots, \alpha_r, c; \beta_1, \dots, \beta_s; \frac{\varrho}{\gamma}\right), \end{aligned} \quad (\text{B.22})$$

for  $r \leq s$ , where  $\text{Re}(c) > 0$  and  $\text{Re}(\gamma) > 0$  if  $r < s$ ; and  $\text{Re}(\gamma) > \text{Re}(\varrho)$  if  $r = s$ .

**Result 14** (*Gradshteyn and Ryzhik, 2007 [11], p.1008*)

$${}_2F_1(\alpha, \beta; c; x) = (1-x)^{-\beta} {}_2F_1\left(\beta, c-\alpha; c; \frac{x}{x-1}\right) \quad (\text{B.23})$$

$${}_2F_1(\alpha, \beta; c; x) = (1-x)^{-\alpha} {}_2F_1\left(\alpha, c-\beta; c; \frac{x}{x-1}\right). \quad (\text{B.24})$$

**Result 15** (*Mathai, 1993 [29], p.69*)

$$x^\alpha G_{r,s}^{m,n} \left( x \Big|_{b_1, \dots, b_s}^{a_1, \dots, a_r} \right) = G_{r,s}^{m,n} \left( x \Big|_{b_1+\alpha, \dots, b_s+\alpha}^{a_1+\alpha, \dots, a_r+\alpha} \right). \quad (\text{B.25})$$

**Result 16** (*Mathai, 1993 [29], p.130*)

$$G_{1,1}^{1,1} \left( cx^\alpha \Big|_{\beta/\alpha}^{1-\gamma+\beta/\alpha} \right) = \frac{c^{\beta/\alpha} \Gamma(\gamma) x^\beta}{(1+cx^\alpha)^\gamma}, \quad |cx^\alpha| < 1. \quad (\text{B.26})$$

**Result 17** (*Mathai, 1993 [29], p.142*)

$$G_{r,s}^{m,n} \left( x \Big|_{b_1, \dots, b_s}^{a_1, \dots, a_r} \right) = H_{r,s}^{m,n} \left( x \Big|_{(b_1,1), \dots, (b_s,1)}^{(a_1,1), \dots, (a_r,1)} \right). \quad (\text{B.27})$$

**Result 18** (*Mathai et al., 2009 [30], p59*)

$$\int_0^c x^{\rho-1} (c-x)^{\sigma-1} H_{r,s}^{m,n} \left( bx^k \Big|_{(b_s, \beta_s)}^{(a_r, \alpha_r)} \right) dx = c^{\rho+\sigma-1} \Gamma(\sigma) H_{r+1, s+1}^{m, n+1} \left( bc^k \Big|_{(b_s, \beta_s), (1-\rho, \sigma, k)}^{(1-\rho, k), (a_r, \alpha_r)} \right), \quad (\text{B.28})$$

for  $\text{Re}(\rho) > 0$ ,  $\text{Re}(b) > 0$  and  $\text{Re}(\sigma) > 0$ ,  $k > 0$ .

**Result 19** (*Johnson et al., 1995 [22], p.248*)

The beta type II distribution, denoted  $X \sim \text{Beta}^{II}(\alpha, \beta)$ , has pdf:

$$f(x) = \frac{\Gamma(\alpha + \beta)}{\Gamma(\alpha)\Gamma(\beta)} x^{\alpha-1} (1+x)^{-(\alpha+\beta)}, \quad (\text{B.29})$$

where  $x > 0$  and  $\alpha, \beta > 0$  and  $\Gamma(\cdot)$  is the gamma function.

**Result 20** (*Johnson et al., 1995 [22], p.325*)

The  $F$  distribution denoted  $X \sim F(v_1, v_2)$  has pdf:

$$f(x) = \frac{\Gamma(\frac{1}{2}(v_1 + v_2))}{\Gamma(\frac{1}{2}v_1)\Gamma(\frac{1}{2}v_2)} \left(\frac{v_1}{v_2}\right)^{\frac{v_1}{2}} x^{\frac{v_1}{2}-1} \left(1 + \frac{v_1}{v_2}x\right)^{-\frac{1}{2}(v_1+v_2)}, \quad (\text{B.30})$$

where  $x > 0$  and  $v_1, v_2 > 0$ .

**Result 21** (*Johnson et al., 1994 [21], p.416*)

The  $\chi^2$  distribution denoted  $X \sim \chi^2(v)$  has pdf:

$$f(x) = \frac{1}{2^{\frac{v}{2}}\Gamma(\frac{1}{2}v)} x^{\frac{v}{2}-1} e^{-\frac{x}{2}}, \quad (\text{B.31})$$

where  $x > 0$  and  $v > 0$ .

**Result 22** (*Johnson et al., 1995 [22], p.438*)

The noncentral  $\chi^2$  distribution denoted  $X \sim \chi_\delta^2(v)$  has pdf:

$$f(x) = \frac{e^{-\frac{\delta}{2}}}{2^{\frac{v}{2}}\Gamma(\frac{v}{2})} {}_0F_1\left(\frac{v}{2}; \frac{\delta x}{4}\right) x^{\frac{v}{2}-1} e^{-\frac{x}{2}}, \quad (\text{B.32})$$

where  $x > 0$  and  $v, \delta > 0$ .

## C. Matrix special functions and theory

**Result 23** (*Gupta and Nagar, 2000 [13], p.7*)

If  $\mathbf{A}$  is a positive definite  $q \times q$  matrix then there exists a positive definite matrix  $\mathbf{B}$  ( $q \times q$ ) such that  $\mathbf{A} = \mathbf{B}^2$ . Furthermore, the square root of  $\mathbf{A}$  is then defined as

$$\mathbf{A}^{\frac{1}{2}} = \mathbf{B}. \quad (\text{C.33})$$

**Result 24** (Gupta and Nagar, 2000 [13], p.18; p.19 )

The multivariate gamma function, denoted  $\Gamma_q(\alpha)$ , is defined as

$$\Gamma_q(\alpha) = \int_{\mathbf{S} > \mathbf{0}} \text{etr}(-\mathbf{S}) |\mathbf{S}|^{\alpha - \frac{1}{2}(q+1)} d\mathbf{S} \quad (\text{C.34})$$

$$\Gamma_q(\alpha) = \pi^{\frac{1}{4}q(q-1)} \prod_{i=1}^q \Gamma\left[\alpha - \frac{1}{2}(i-1)\right], \quad (\text{C.35})$$

where  $\text{Re}(\alpha) > \frac{1}{2}(q-1)$ , and the integral is over the space of  $q \times q$  symmetric positive definite matrices.

For  $q = 1$  it simplifies to the gamma function.

**Result 25** (Gupta and Nagar, 2000 [13], p.20)

The multivariate beta function, denoted by  $\beta_q(\alpha, \beta)$ , is defined as

$$\beta_q(\alpha, \beta) = \int_{\mathbf{0} < \mathbf{S} < \mathbf{I}_q} |\mathbf{S}|^{\alpha - \frac{1}{2}(q+1)} |\mathbf{I}_q - \mathbf{S}|^{\beta - \frac{1}{2}(q+1)} d\mathbf{S}$$

$$\beta_q(\alpha, \beta) = \frac{\Gamma_q(\alpha) \Gamma_q(\beta)}{\Gamma_q(\alpha + \beta)}, \quad (\text{C.36})$$

where  $\text{Re}(\alpha) > \frac{1}{2}(q-1)$ ,  $\text{Re}(\beta) > \frac{1}{2}(q-1)$  and  $\Gamma_q(\cdot)$  is the multivariate gamma function.

For  $q = 1$  it simplifies to the beta function.

**Result 26** (Gupta and Nagar, 2000 [13], p.21)

The multivariate Dirichlet function is defined as

$$\beta_q(\alpha_1, \dots, \alpha_r; \beta) = \frac{\Gamma_q(\beta) \prod_{i=1}^r \Gamma_q(\alpha_i)}{\Gamma_q(\alpha + \beta)}, \quad (\text{C.37})$$

where  $\text{Re}(\alpha_i) > \frac{1}{2}(q-1)$ ,  $i = 1, \dots, r$ ,  $\text{Re}(\beta) > \frac{1}{2}(q-1)$  and  $\alpha = \sum_{i=1}^r \alpha_i$ .

**Result 27** (Gupta and Nagar, 2000 [13], p.30)

Let  $\tau = (t_1, \dots, t_q)$ ,  $t_1 \geq \dots \geq t_q \geq 0$ ,  $t_1 + \dots + t_q = t$ . The generalised hypergeometric coefficient  $(\alpha)_\tau$ , also known as the generalised Pochhammer symbol of weight  $\tau$ , is defined as

$$(\alpha)_\tau = \prod_{i=1}^q \left(\alpha - \frac{1}{2}(i-1)\right)_{t_i} \quad (\text{C.38})$$

$$(\alpha)_\tau = \frac{\pi^{\frac{1}{4}q(q-1)} \prod_{j=1}^q \Gamma\left[\alpha + t_j - \frac{1}{2}(j-1)\right]}{\Gamma_q(\alpha)},$$



where  $\operatorname{Re}(\alpha) > \frac{1}{2}(q-1) - t_q$ ,  $\Gamma(\cdot)$  is the gamma function and  $\Gamma_q(\cdot)$  is the multivariate gamma function.

For  $q = 1$  it simplifies to the Pochhammer coefficient.

**Result 28** (*Gupta and Nagar, 2000 [13], p.30*)

Let  $\tau = (t_1, \dots, t_q)$ ,  $t_1 \geq \dots \geq t_q \geq 0$ ,  $t_1 + \dots + t_q = t$ . The generalised gamma function of weight  $\tau$  is defined as

$$\Gamma_q(\alpha, \tau) = \pi^{\frac{1}{4}q(q-1)} \prod_{j=1}^q \Gamma\left[\alpha + t_j - \frac{1}{2}(j-1)\right] \quad (\text{C.39})$$

$$\Gamma_q(\alpha, \tau) = (\alpha)_\tau \Gamma_q(\alpha), \quad (\text{C.40})$$

where the integral is over the space of  $q \times q$  symmetric positive definite matrices,  $(\alpha)_\tau$  is the generalised hypergeometric coefficient,  $\operatorname{Re}(\alpha) \geq \frac{1}{2}(q-1) - t_q$  and  $\Gamma_q(\alpha, 0) = \Gamma_q(\alpha)$ .

**Result 29** (*Gupta and Nagar, 2000 [13], p.12*)

For matrix transformations  $\mathbf{Y} = F(\mathbf{X})$  and  $\mathbf{Z} = G(\mathbf{W})$  is

$$J(\mathbf{X}, \mathbf{W} \rightarrow \mathbf{Y}, \mathbf{Z}) = J(\mathbf{X} \rightarrow \mathbf{Y}) J(\mathbf{W} \rightarrow \mathbf{Z}). \quad (\text{C.41})$$

If  $\mathbf{Y}$  ( $q \times q$ ) and  $\mathbf{X}$  ( $q \times q$ ) are symmetric matrices,  $\mathbf{A}$  ( $q \times q$ ) and  $\mathbf{Y} = \mathbf{A}\mathbf{X}\mathbf{A}'$ , then

$$J(\mathbf{Y} \rightarrow \mathbf{X}) = |\mathbf{A}|^{q+1}. \quad (\text{C.42})$$

A brief description of zonal polynomials and results involving zonal polynomials are given next. For a more detailed discussion see James (1960 [18], 1961 [19], 1964 [20]), Constantine (1963) [6] and Khatri (1966) [24].

**Result 30** (*Gupta and Nagar, 2000 [13], p.29*)

Let  $\mathbf{S}$  be a ( $q \times q$ ) symmetric matrix and let  $V_t$  be the vector space of homogeneous polynomials  $\varphi(\mathbf{S})$  of degree  $t$  in the  $\frac{1}{2}q(q+1)$  distinct elements of  $\mathbf{S}$ . The space  $V_t$  can be decomposed into a direct sum of irreducible invariant subspaces  $V_\tau$  where  $\tau = (t_1, \dots, t_q)$ ,  $t_1 \geq \dots \geq t_q \geq 0$ ,  $t_1 + \dots + t_q = t$ . The polynomial  $(\operatorname{tr}\mathbf{S})^t \in V_t$  has a unique decomposition

$$(\operatorname{tr}\mathbf{S})^t = \sum_{\tau} C_{\tau}(\mathbf{S}), \quad (\text{C.43})$$

into polynomials,  $C_{\tau}(\mathbf{S}) \in V_{\tau}$ , belonging to the respective invariant subspaces.

The zonal polynomial  $C_{\tau}(\mathbf{S})$  is defined as the component of  $(\operatorname{tr}\mathbf{S})^t$  in the subspace  $V_{\tau}$ . It is a symmetric homogeneous polynomial of degree  $t$  in the latent roots of  $\mathbf{S}$  and holds for all  $q$ . If the partition  $\tau$  has more than  $q$  parts, the corresponding zonal polynomial will be identically zero.

**Result 31** (Ehlers, 2011 [9], p.9; Muirhead, 1982 [32], p.243; Gupta and Nagar, 2000 [13], p.30)

If  $\mathbf{S}$  ( $q \times q$ ) is a symmetric matrix,  $\mathbf{R}$  ( $q \times q$ )  $> \mathbf{0}$  and  $\mathbf{T}$  ( $q \times q$ )  $> \mathbf{0}$ , then

$$\int_{O(q)} C_{\tau} \left( \mathbf{R}^{\frac{1}{2}} \mathbf{T} \mathbf{R}^{\frac{1}{2}} \mathbf{H} \mathbf{S} \mathbf{H}' \right) d\mathbf{H} = \int_{O(q)} C_{\tau} \left( \mathbf{T}^{\frac{1}{2}} \mathbf{R} \mathbf{T}^{\frac{1}{2}} \mathbf{H} \mathbf{S} \mathbf{H}' \right) d\mathbf{H}, \quad (\text{C.44})$$

where  $O(q) = \{\mathbf{H} (q \times q) | \mathbf{H} \mathbf{H}' = \mathbf{H}' \mathbf{H} = \mathbf{I}_q\}$  and  $d\mathbf{H}$  denotes the normalised Haar invariant measure on the orthogonal group  $O(q)$  (see Muirhead, 1982 [32], p.72).

**Proof.** From Muirhead, 1982 [32], Theorem 7.2.5 and Gupta and Nagar, 2000 [13], Equation 1.5.3 it follows that

$$\begin{aligned} \int_{O(q)} C_{\tau} \left( \mathbf{R}^{\frac{1}{2}} \mathbf{T} \mathbf{R}^{\frac{1}{2}} \mathbf{H} \mathbf{S} \mathbf{H}' \right) d\mathbf{H} &= \frac{C_{\tau} \left( \mathbf{R}^{\frac{1}{2}} \mathbf{T} \mathbf{R}^{\frac{1}{2}} \right) C_{\tau} (\mathbf{S})}{C_{\tau} (\mathbf{I}_q)} \\ &= \frac{C_{\tau} \left( \mathbf{T}^{\frac{1}{2}} \mathbf{R} \mathbf{T}^{\frac{1}{2}} \right) C_{\tau} (\mathbf{S})}{C_{\tau} (\mathbf{I}_q)} \\ &= \int_{O(q)} C_{\tau} \left( \mathbf{T}^{\frac{1}{2}} \mathbf{R} \mathbf{T}^{\frac{1}{2}} \mathbf{H} \mathbf{S} \mathbf{H}' \right) d\mathbf{H}. \end{aligned}$$

■

### Result 32

If  $\mathbf{S}$  ( $q \times q$ ) is a symmetric matrix,  $\mathbf{V}$  ( $q \times q$ )  $> \mathbf{0}$ ,  $\mathbf{W}$  ( $q \times q$ )  $> \mathbf{0}$  and  $\mathbf{A}$  ( $q \times q$ )  $> \mathbf{0}$ , then

$$\int_{O(q)} C_{\tau} \left( \mathbf{V}^{\frac{1}{2}} \mathbf{A}^{\frac{1}{2}} \mathbf{W} \mathbf{A}^{\frac{1}{2}} \mathbf{V}^{\frac{1}{2}} \mathbf{H} \mathbf{S} \mathbf{H}' \right) d\mathbf{H} = \int_{O(q)} C_{\tau} \left( \mathbf{W}^{\frac{1}{2}} \mathbf{A}^{\frac{1}{2}} \mathbf{V} \mathbf{A}^{\frac{1}{2}} \mathbf{W}^{\frac{1}{2}} \mathbf{H} \mathbf{S} \mathbf{H}' \right) d\mathbf{H}. \quad (\text{C.45})$$

**Proof.** From Muirhead, 1982 [32], Theorem 7.2.5 and Gupta and Nagar, 2000 [13], Equation 1.5.3 it follows that

$$\begin{aligned} \int_{O(q)} C_{\tau} \left( \mathbf{V}^{\frac{1}{2}} \mathbf{A}^{\frac{1}{2}} \mathbf{W} \mathbf{A}^{\frac{1}{2}} \mathbf{V}^{\frac{1}{2}} \mathbf{H} \mathbf{S} \mathbf{H}' \right) d\mathbf{H} &= \frac{C_{\tau} \left( \mathbf{V}^{\frac{1}{2}} \mathbf{A}^{\frac{1}{2}} \mathbf{W} \mathbf{A}^{\frac{1}{2}} \mathbf{V}^{\frac{1}{2}} \right) C_{\tau} (\mathbf{S})}{C_{\tau} (\mathbf{I}_q)} \\ &= \frac{C_{\tau} \left( \mathbf{W}^{\frac{1}{2}} \mathbf{A}^{\frac{1}{2}} \mathbf{V} \mathbf{A}^{\frac{1}{2}} \mathbf{W}^{\frac{1}{2}} \right) C_{\tau} (\mathbf{S})}{C_{\tau} (\mathbf{I}_q)} \\ &= \int_{O(q)} C_{\tau} \left( \mathbf{W}^{\frac{1}{2}} \mathbf{A}^{\frac{1}{2}} \mathbf{V} \mathbf{A}^{\frac{1}{2}} \mathbf{W}^{\frac{1}{2}} \mathbf{H} \mathbf{S} \mathbf{H}' \right) d\mathbf{H}. \end{aligned}$$

■

**Result 33**

If  $\mathbf{S}$  ( $q \times q$ ) is a symmetric matrix,  $\mathbf{R}$  ( $q \times q$ )  $> \mathbf{0}$ ,  $\mathbf{T}$  ( $q \times q$ )  $> \mathbf{0}$ ,  $\mathbf{V}$  ( $q \times q$ )  $> \mathbf{0}$  and  $\mathbf{W}$  ( $q \times q$ )  $> \mathbf{0}$ , then

$$\begin{aligned} & \int_{O(q)} C_{\zeta} \left( \mathbf{R}^{\frac{1}{2}} \mathbf{T} \mathbf{R}^{\frac{1}{2}} \mathbf{H} \mathbf{S} \mathbf{H}' \right) C_{\tau} \left( \mathbf{V}^{\frac{1}{2}} \mathbf{W} \mathbf{V}^{\frac{1}{2}} \mathbf{H} \mathbf{S} \mathbf{H}' \right) d\mathbf{H} \\ \text{(a)} &= \int_{O(q)} C_{\zeta} \left( \mathbf{R}^{\frac{1}{2}} \mathbf{T} \mathbf{R}^{\frac{1}{2}} \mathbf{H} \mathbf{S} \mathbf{H}' \right) C_{\tau} \left( \mathbf{W}^{\frac{1}{2}} \mathbf{V} \mathbf{W}^{\frac{1}{2}} \mathbf{H} \mathbf{S} \mathbf{H}' \right) d\mathbf{H} \end{aligned} \quad (\text{C.46})$$

$$\text{(b)} = \int_{O(q)} C_{\zeta} \left( \mathbf{T}^{\frac{1}{2}} \mathbf{R} \mathbf{T}^{\frac{1}{2}} \mathbf{H} \mathbf{S} \mathbf{H}' \right) C_{\tau} \left( \mathbf{W}^{\frac{1}{2}} \mathbf{V} \mathbf{W}^{\frac{1}{2}} \mathbf{H} \mathbf{S} \mathbf{H}' \right) d\mathbf{H}. \quad (\text{C.47})$$

**Proof.** (b) From Davis (1979) [7] follows that

$$\begin{aligned} & \int_{O(q)} C_{\zeta} \left( \mathbf{R}^{\frac{1}{2}} \mathbf{T} \mathbf{R}^{\frac{1}{2}} \mathbf{H} \mathbf{S} \mathbf{H}' \right) C_{\tau} \left( \mathbf{V}^{\frac{1}{2}} \mathbf{W} \mathbf{V}^{\frac{1}{2}} \mathbf{H} \mathbf{S} \mathbf{H}' \right) d\mathbf{H} \\ &= \sum_{\phi \in \zeta, \tau} \frac{C_{\phi}^{\zeta, \tau} \left( \mathbf{R}^{\frac{1}{2}} \mathbf{T} \mathbf{R}^{\frac{1}{2}}, \mathbf{V}^{\frac{1}{2}} \mathbf{W} \mathbf{V}^{\frac{1}{2}} \right) C_{\phi}^{\zeta, \tau} (\mathbf{S}, \mathbf{S})}{C_{\phi}(\mathbf{I}_q)} \\ &= \sum_{\phi \in \zeta, \tau} \frac{C_{\phi}^{\zeta, \tau} \left( \mathbf{T}^{\frac{1}{2}} \mathbf{R} \mathbf{T}^{\frac{1}{2}}, \mathbf{W}^{\frac{1}{2}} \mathbf{V} \mathbf{W}^{\frac{1}{2}} \right) C_{\phi}^{\zeta, \tau} (\mathbf{S}, \mathbf{S})}{C_{\phi}(\mathbf{I}_q)} \\ &= \int_{O(q)} C_{\zeta} \left( \mathbf{T}^{\frac{1}{2}} \mathbf{R} \mathbf{T}^{\frac{1}{2}} \mathbf{H} \mathbf{S} \mathbf{H}' \right) C_{\tau} \left( \mathbf{W}^{\frac{1}{2}} \mathbf{V} \mathbf{W}^{\frac{1}{2}} \mathbf{H} \mathbf{S} \mathbf{H}' \right) d\mathbf{H}. \end{aligned}$$

The proof for (a) is similar. ■

**Result 34**

If  $\mathbf{S}$  ( $q \times q$ ) is a symmetric matrix,  $\mathbf{R}$  ( $q \times q$ )  $> \mathbf{0}$ ,  $\mathbf{T}$  ( $q \times q$ )  $> \mathbf{0}$ ,  $\mathbf{V}$  ( $q \times q$ )  $> \mathbf{0}$ ,  $\mathbf{W}$  ( $q \times q$ )  $> \mathbf{0}$  and  $\mathbf{A}$  ( $q \times q$ )  $> \mathbf{0}$ , then

$$\begin{aligned} & \int_{O(q)} C_{\zeta} \left( \mathbf{R}^{\frac{1}{2}} \mathbf{T} \mathbf{R}^{\frac{1}{2}} \mathbf{H} \mathbf{S} \mathbf{H}' \right) C_{\tau} \left( \mathbf{V}^{\frac{1}{2}} \mathbf{A}^{\frac{1}{2}} \mathbf{W} \mathbf{A}^{\frac{1}{2}} \mathbf{V}^{\frac{1}{2}} \mathbf{H} \mathbf{S} \mathbf{H}' \right) d\mathbf{H} \\ &= \int_{O(q)} C_{\zeta} \left( \mathbf{T}^{\frac{1}{2}} \mathbf{R} \mathbf{T}^{\frac{1}{2}} \mathbf{H} \mathbf{S} \mathbf{H}' \right) C_{\tau} \left( \mathbf{W}^{\frac{1}{2}} \mathbf{A}^{\frac{1}{2}} \mathbf{V} \mathbf{A}^{\frac{1}{2}} \mathbf{W}^{\frac{1}{2}} \mathbf{H} \mathbf{S} \mathbf{H}' \right) d\mathbf{H}. \end{aligned} \quad (\text{C.48})$$

**Proof.** From Davis (1979) [7]

$$\begin{aligned} & \int_{O(q)} C_{\zeta} \left( \mathbf{R}^{\frac{1}{2}} \mathbf{T} \mathbf{R}^{\frac{1}{2}} \mathbf{H} \mathbf{S} \mathbf{H}' \right) C_{\tau} \left( \mathbf{V}^{\frac{1}{2}} \mathbf{A}^{\frac{1}{2}} \mathbf{W} \mathbf{A}^{\frac{1}{2}} \mathbf{V}^{\frac{1}{2}} \mathbf{H} \mathbf{S} \mathbf{H}' \right) d\mathbf{H} \\ &= \sum_{\phi \in \zeta, \tau} \frac{C_{\phi}^{\zeta, \tau} \left( \mathbf{R}^{\frac{1}{2}} \mathbf{T} \mathbf{R}^{\frac{1}{2}}, \mathbf{V}^{\frac{1}{2}} \mathbf{A}^{\frac{1}{2}} \mathbf{W} \mathbf{A}^{\frac{1}{2}} \mathbf{V}^{\frac{1}{2}} \right) C_{\phi}^{\zeta, \tau} (\mathbf{S}, \mathbf{S})}{C_{\phi}(\mathbf{I}_q)} \end{aligned}$$

$$\begin{aligned}
 &= \sum_{\phi \in \mathcal{S}, \tau} \frac{C_{\phi}^{\mathcal{S}, \tau} \left( \mathbf{T}^{\frac{1}{2}} \mathbf{R} \mathbf{T}^{\frac{1}{2}}, \mathbf{W}^{\frac{1}{2}} \mathbf{A}^{\frac{1}{2}} \mathbf{V} \mathbf{A}^{\frac{1}{2}} \mathbf{W}^{\frac{1}{2}} \right) C_{\phi}^{\mathcal{S}, \tau} (\mathbf{S}, \mathbf{S})}{C_{\phi} (\mathbf{I}_q)} \\
 &= \int_{O(q)} C_{\mathcal{S}} \left( \mathbf{T}^{\frac{1}{2}} \mathbf{R} \mathbf{T}^{\frac{1}{2}} \mathbf{H} \mathbf{S} \mathbf{H}' \right) C_{\tau} \left( \mathbf{W}^{\frac{1}{2}} \mathbf{A}^{\frac{1}{2}} \mathbf{V} \mathbf{A}^{\frac{1}{2}} \mathbf{W}^{\frac{1}{2}} \mathbf{H} \mathbf{S} \mathbf{H}' \right) d\mathbf{H}.
 \end{aligned}$$

■

**Result 35** (*Constantine, 1963 [6]; Gupta and Nagar, 2000 [13], p.34*)

The hypergeometric function of matrix argument is defined by

$${}_r F_s (\alpha_1, \dots, \alpha_r; \beta_1, \dots, \beta_s; \mathbf{S}) = \sum_{t=0}^{\infty} \sum_{\tau} \frac{(\alpha_1)_{\tau} \dots (\alpha_r)_{\tau}}{(\beta_1)_{\tau} \dots (\beta_s)_{\tau}} \frac{1}{t!} C_{\tau} (\mathbf{S}), \quad (\text{C.49})$$

where  $\alpha_i, i = 1, \dots, r; \beta_j, j = 1, \dots, s$  are arbitrary numbers,  $\mathbf{S} (q \times q)$  is a real symmetric matrix,  $\sum_{\tau}$  denotes summation over all partitions  $\tau$ ,  $C_{\tau} (\mathbf{S})$  is the zonal polynomial of  $\mathbf{S}$ ,  $(\alpha)_{\tau}$  is the generalised hypergeometric coefficient.

Conditions for the convergence of the series

- (i) the series converges for all  $\mathbf{S} (q \times q)$  if  $r < s + 1$ , otherwise the series may only converge for  $\mathbf{S} = \mathbf{0}$ ;
- (ii) for  $r = s + 1$  the series converges for  $\|\mathbf{S}\| < 1$  (where  $\|\mathbf{S}\|$  denotes the maximum of the absolute values of the characteristic roots of  $\mathbf{S}$ );
- (iii) for  $r \leq s$  the series converges for all  $\mathbf{S}$ ;
- (iv) for  $r > s + 1$  the series diverges for all  $\mathbf{S} \neq \mathbf{0}$  unless the series terminates;
- (v) none of the  $\beta_j$  is zero, an integer or half integer  $\leq \frac{1}{2}(q - 1)$  (otherwise some of the denominators in (C.49) will vanish);
- (vi) if  $\alpha_i$  is a negative integer, say  $-w$ , then for  $t \geq qw + 1$ , all coefficients in (C.49) vanish and the function reduces to a finite polynomial of degree  $qw$ .

**Result 36** (*Constantine, 1963 [6]*)

$${}_0 F_0 (\mathbf{S}) = \sum_{t=0}^{\infty} \sum_{\tau} \frac{C_{\tau} (\mathbf{S})}{t!} = \text{etr} (\mathbf{S}). \quad (\text{C.50})$$

**Result 37** (*Herz, 1955 [16]*)

If  $\mathbf{X}$  ( $q \times q$ ) is a symmetric matrix where  $\|\mathbf{X}\| < 1$ , then

$${}_1F_0(\alpha; \mathbf{X}) = \frac{1}{\Gamma_q(\alpha)} \int_{\mathbf{S} > \mathbf{0}} \text{etr}[-\mathbf{S}(\mathbf{I}_q - \mathbf{X})] |\mathbf{S}|^{\alpha - \frac{1}{2}(q+1)} d\mathbf{S} = |\mathbf{I}_q - \mathbf{X}|^{-\alpha}, \quad (\text{C.51})$$

where  $\text{Re}(\alpha) > \frac{1}{2}(q-1)$ .

**Result 38** (*Gupta and Nagar, 2000 [13], p.36*)

If  $\mathbf{X}$  ( $q \times q$ ) is a symmetric matrix where  $\|\mathbf{X}\| < 1$ , then

$$\begin{aligned} & {}_2F_1(\alpha, \beta; c; \mathbf{X}) \\ &= \frac{\Gamma_q(c)}{\Gamma_q(\alpha)\Gamma_q(c-\alpha)} \int_{\mathbf{0} < \mathbf{S} < \mathbf{I}_q} |\mathbf{S}|^{\alpha - \frac{1}{2}(q+1)} |\mathbf{I}_q - \mathbf{S}|^{c - \alpha - \frac{1}{2}(q+1)} |\mathbf{I}_q - \mathbf{XS}|^{-\beta} d\mathbf{S}, \end{aligned} \quad (\text{C.52})$$

where  $\text{Re}(c) > \frac{1}{2}(q-1)$  and  $\text{Re}(c-\alpha) > \frac{1}{2}(q-1)$ . This is known as the Gauss hypergeometric function of matrix argument.

**Result 39** (*Gupta and Nagar, 2000 [13], p.51*)

$$\begin{aligned} & \int_{\mathbf{S} > \mathbf{0}} |\mathbf{S}|^{\alpha - \frac{1}{2}(q+1)} |\mathbf{I}_q + \mathbf{S}|^{-\beta} |\mathbf{I}_q + \mathbf{BS}|^{-c} d\mathbf{S} \\ &= \beta_q(\alpha, \beta + c - \alpha) |\mathbf{B}|^{-c} {}_2F_1(\beta + c - \alpha, c; \beta + c; \mathbf{I}_q - \mathbf{B}^{-1}), \end{aligned} \quad (\text{C.53})$$

where  $\|\mathbf{I}_q - \mathbf{B}^{-1}\| < 1$ ,  $\text{Re}(\beta + c - \alpha) > \frac{1}{2}(q-1)$ , and  $\text{Re}(\alpha) > \frac{1}{2}(q-1)$ ,  $\beta_q(\cdot)$  is the multivariate beta function and  ${}_2F_1(\cdot)$  is the Gauss hypergeometric function of matrix argument.

**Result 40** (*Herz, 1955 [16]*)

For  $\text{Re}(\mathbf{X}) > \mathbf{0}$  and  $\text{Re}(\alpha) > \frac{1}{2}(q-1)$ , then

$$\int_{\mathbf{S} > \mathbf{0}} \text{etr}(-\mathbf{SX}) |\mathbf{S}|^{\alpha - \frac{1}{2}(q+1)} d\mathbf{S} = \Gamma_q(\alpha) |\mathbf{X}|^{-\alpha}, \quad (\text{C.54})$$

where  $\Gamma_q(\cdot)$  is the multivariate gamma function.

**Result 41** (*Gupta and Nagar, 2000 [13], p.37; Muirhead, 1982 [32], p.265*)

$${}_2F_1(\alpha, \beta; c; \mathbf{X}) = |\mathbf{I}_q - \mathbf{X}|^{-\beta} {}_2F_1(c - \alpha, \beta; c; -\mathbf{X}(\mathbf{I}_q - \mathbf{X})^{-1}). \quad (\text{C.55})$$

**Result 42** (Gupta and Nagar, 2000 [13], p.38 and p.52)

The confluent hypergeometric function  $\Psi$  of symmetric matrix  $\mathbf{R}$  ( $q \times q$ ) is defined by

$$\Psi(\alpha, c, \mathbf{R}) = \frac{1}{\Gamma_q(\alpha)} \int_{\mathbf{S} > \mathbf{0}} \text{etr}(-\mathbf{RS}) |\mathbf{S}|^{\alpha - \frac{1}{2}(q+1)} |\mathbf{I}_q + \mathbf{S}|^{c - \alpha - \frac{1}{2}(q+1)} d\mathbf{S} \quad (\text{C.56})$$

where  $\mathbf{R} > \mathbf{0}$  and  $\text{Re}(\alpha) > \frac{1}{2}(q-1)$ .

Then

$$\begin{aligned} & \int_{\mathbf{Y} > \mathbf{0}} |\mathbf{Y}|^{\beta - \frac{1}{2}(q+1)} \text{etr}(-\mathbf{XY}) \Psi(\alpha, c, \mathbf{Y}) d\mathbf{Y} \\ &= \frac{\Gamma_q(\beta) \Gamma_q(\beta - c + \frac{1}{2}(q+1))}{\Gamma_q(\alpha + \beta - c + \frac{1}{2}(q+1))} \\ & \quad \times {}_2F_1\left(\beta - c + \frac{1}{2}(q+1), \beta; \alpha + \beta - c + \frac{1}{2}(q+1); \mathbf{I}_q - \mathbf{X}\right) \end{aligned} \quad (\text{C.57})$$

where  $\|\mathbf{I}_q - \mathbf{X}\| < 1$  and  $\text{Re}(\alpha) > \frac{1}{2}(q-1)$ ,  $\text{Re}(\beta - c) > -1$ .

**Proof.**

$$\begin{aligned} & \int_{\mathbf{Y} > \mathbf{0}} |\mathbf{Y}|^{\beta - \frac{1}{2}(q+1)} \text{etr}(-\mathbf{XY}) \Psi(\alpha, c, \mathbf{Y}) d\mathbf{Y} \\ &= \int_{\mathbf{Y} > \mathbf{0}} |\mathbf{Y}|^{\beta - \frac{1}{2}(q+1)} \text{etr}(-\mathbf{XY}) \frac{1}{\Gamma_q(\alpha)} \int_{\mathbf{S} > \mathbf{0}} \text{etr}(-\mathbf{YS}) |\mathbf{S}|^{\alpha - \frac{1}{2}(q+1)} |\mathbf{I}_q + \mathbf{S}|^{c - \alpha - \frac{1}{2}(q+1)} d\mathbf{S} d\mathbf{Y} \\ &= \frac{1}{\Gamma_q(\alpha)} \int_{\mathbf{S} > \mathbf{0}} |\mathbf{S}|^{\alpha - \frac{1}{2}(q+1)} |\mathbf{I}_q + \mathbf{S}|^{c - \alpha - \frac{1}{2}(q+1)} \int_{\mathbf{Y} > \mathbf{0}} |\mathbf{Y}|^{\beta - \frac{1}{2}(q+1)} \text{etr}(-(\mathbf{X} + \mathbf{S})\mathbf{Y}) d\mathbf{Y} d\mathbf{S} \\ &= \frac{1}{\Gamma_q(\alpha)} \int_{\mathbf{S} > \mathbf{0}} |\mathbf{S}|^{\alpha - \frac{1}{2}(q+1)} |\mathbf{I}_q + \mathbf{S}|^{c - \alpha - \frac{1}{2}(q+1)} \Gamma_q(\beta) |\mathbf{X} + \mathbf{S}|^{-\beta} d\mathbf{S} \text{ using (C.54)} \\ &= \frac{\Gamma_q(\beta)}{\Gamma_q(\alpha)} \int_{\mathbf{S} > \mathbf{0}} |\mathbf{S}|^{\alpha - \frac{1}{2}(q+1)} |\mathbf{I}_q + \mathbf{S}|^{c - \alpha - \frac{1}{2}(q+1)} \left| \mathbf{X}^{\frac{1}{2}} \left( \mathbf{I}_q + \mathbf{X}^{-\frac{1}{2}} \mathbf{S} \mathbf{X}^{-\frac{1}{2}} \right) \mathbf{X}^{\frac{1}{2}} \right|^{-\beta} d\mathbf{S} \\ &= \frac{\Gamma_q(\beta)}{\Gamma_q(\alpha)} |\mathbf{X}|^{-\beta} \int_{\mathbf{S} > \mathbf{0}} |\mathbf{S}|^{\alpha - \frac{1}{2}(q+1)} |\mathbf{I}_q + \mathbf{S}|^{-(\alpha - c + \frac{1}{2}(q+1))} |\mathbf{I}_q + \mathbf{X}^{-1} \mathbf{S}|^{-\beta} d\mathbf{S} \\ &= \frac{\Gamma_q(\beta)}{\Gamma_q(\alpha)} |\mathbf{X}|^{-\beta} \beta_q\left(\alpha, \beta - c + \frac{1}{2}(q+1)\right) |\mathbf{X}^{-1}|^{-\beta} \\ & \quad \times {}_2F_1\left(\beta - c + \frac{1}{2}(q+1), \beta; \alpha + \beta - c + \frac{1}{2}(q+1); \mathbf{I}_q - \mathbf{X}\right) \text{ using (C.53)} \\ &= \frac{\Gamma_q(\beta) \Gamma_q(\beta - c + \frac{1}{2}(q+1))}{\Gamma_q(\alpha + \beta - c + \frac{1}{2}(q+1))} \\ & \quad \times {}_2F_1\left(\beta - c + \frac{1}{2}(q+1), \beta; \alpha + \beta - c + \frac{1}{2}(q+1); \mathbf{I}_q - \mathbf{X}\right). \end{aligned}$$

■

Furthermore, let  $\mathbf{B} > \mathbf{0}$

$$\begin{aligned}
 & \int_{\mathbf{Y} > \mathbf{0}} |\mathbf{Y}|^{\beta - \frac{1}{2}(q+1)} \text{etr}(-\mathbf{X}\mathbf{Y}) \Psi\left(\alpha, c, \mathbf{B}^{\frac{1}{2}}\mathbf{Y}\mathbf{B}^{\frac{1}{2}}\right) d\mathbf{Y} \\
 &= |\mathbf{B}|^{-\beta} \frac{\Gamma_q(\beta) \Gamma_q\left(\beta - c + \frac{1}{2}(q+1)\right)}{\Gamma_q\left(\alpha + \beta - c + \frac{1}{2}(q+1)\right)} \\
 & \quad \times {}_2F_1\left(\beta - c + \frac{1}{2}(q+1), \beta; \left(\alpha + \beta - c + \frac{1}{2}(q+1)\right); \mathbf{I}_q - \mathbf{B}^{-\frac{1}{2}}\mathbf{X}\mathbf{B}^{-\frac{1}{2}}\right)
 \end{aligned} \tag{C.58}$$

where  $\left\| \mathbf{I}_q - \mathbf{B}^{-\frac{1}{2}}\mathbf{X}\mathbf{B}^{-\frac{1}{2}} \right\| < 1$ .

**Proof.** Let  $\mathbf{Z} = \mathbf{B}^{\frac{1}{2}}\mathbf{Y}\mathbf{B}^{\frac{1}{2}}$ , then  $\mathbf{Y} = \mathbf{B}^{-\frac{1}{2}}\mathbf{Z}\mathbf{B}^{-\frac{1}{2}}$  with Jacobian  $J(\mathbf{Y} \rightarrow \mathbf{Z}) = |\mathbf{B}|^{-\frac{1}{2}(q+1)}$ . Then

$$\begin{aligned}
 & \int_{\mathbf{Z} > \mathbf{0}} \left| \mathbf{B}^{-\frac{1}{2}}\mathbf{Z}\mathbf{B}^{-\frac{1}{2}} \right|^{\beta - \frac{1}{2}(q+1)} \text{etr}\left(-\mathbf{X}\mathbf{B}^{-\frac{1}{2}}\mathbf{Z}\mathbf{B}^{-\frac{1}{2}}\right) \Psi(\alpha, c, \mathbf{Z}) |\mathbf{B}|^{-\frac{1}{2}(q+1)} d\mathbf{Z} \\
 &= |\mathbf{B}|^{-\beta} \int_{\mathbf{Z} > \mathbf{0}} |\mathbf{Z}|^{\beta - \frac{1}{2}(q+1)} \text{etr}\left(-\mathbf{B}^{-\frac{1}{2}}\mathbf{X}\mathbf{B}^{-\frac{1}{2}}\mathbf{Z}\right) \Psi(\alpha, c, \mathbf{Z}) d\mathbf{Z} \\
 &= |\mathbf{B}|^{-\beta} \frac{\Gamma_q(\beta) \Gamma_q\left(\beta - c + \frac{1}{2}(q+1)\right)}{\Gamma_q\left(\alpha + \beta - c + \frac{1}{2}(q+1)\right)} \quad \text{using (C.57)} \\
 & \quad \times {}_2F_1\left(\beta - c + \frac{1}{2}(q+1), \beta; \left(\alpha + \beta - c + \frac{1}{2}(q+1)\right); \mathbf{I}_q - \mathbf{B}^{-\frac{1}{2}}\mathbf{X}\mathbf{B}^{-\frac{1}{2}}\right).
 \end{aligned}$$

■

**Result 43** (*Gupta and Nagar, 2000 [13], p.87*)

A  $q \times q$  random symmetric positive definite matrix  $\mathbf{S}$  is said to have a Wishart distribution with parameters  $q$ ,  $v$ , and  $\boldsymbol{\Sigma}$  ( $q \times q$ )  $> \mathbf{0}$ , written as  $\mathbf{S} \sim W_q(v, \boldsymbol{\Sigma})$ , if its pdf is given by

$$\left\{ 2^{\frac{1}{2}vq} \Gamma_q\left(\frac{v}{2}\right) |\boldsymbol{\Sigma}|^{\frac{1}{2}v} \right\}^{-1} |\mathbf{S}|^{\frac{1}{2}(v-q-1)} \text{etr}\left(-\frac{1}{2}\boldsymbol{\Sigma}^{-1}\mathbf{S}\right), \quad \mathbf{S} > \mathbf{0}, \quad v \geq q, \tag{C.59}$$

where  $\Gamma_q(\cdot)$  is the multivariate gamma function.

**Result 44** (*Muirhead, 1982 [32], p.101*)

The  $h^{th}$  moment of  $\mathbf{X}$  where  $\mathbf{X} \sim W_q(v, \boldsymbol{\Sigma})$  is

$$E\left(|\mathbf{X}|^h\right) = |\boldsymbol{\Sigma}|^h 2^{qh} \frac{\Gamma_q\left(\frac{1}{2}v + h\right)}{\Gamma_q\left(\frac{1}{2}v\right)}. \tag{C.60}$$

**Result 45** (*Gupta and Nagar (2000) [13], p.166*)

A  $q \times q$  random symmetric positive definite matrix  $\mathbf{S}$  is said to have a matrix variate beta type II distribution with parameters  $(\alpha, \beta)$ , denoted as  $\mathbf{S} \sim B_q^{II}(\alpha, \beta)$ , if its pdf is given by

$$[\beta_q(\alpha, \beta)]^{-1} |\mathbf{S}|^{\alpha - \frac{1}{2}(q+1)} |\mathbf{I}_q + \mathbf{S}|^{-(\alpha+\beta)}, \quad (\text{C.61})$$

$\mathbf{S} > \mathbf{0}$  where  $\alpha > \frac{1}{2}(q-1)$ ,  $\beta > \frac{1}{2}(q-1)$  and  $\beta_q(\cdot)$  is the multivariate beta function.



# Bibliography

- [1] Adamski, K., Human, S.W. and Bekker, A. (2012). A generalized multivariate beta distribution: control charting when the measurements are from an exponential distribution, *Statistical Papers*, 53, 1045-1064.
- [2] Arnold, B.C. and Ng, H.K.T. (2011). Flexible bivariate beta distributions, *Journal of Multivariate Analysis*, doi:10.1016/j.jmva.2011.04.001.
- [3] Bain, L.J. and Engelhardt, M. (1992). *Introduction to probability and mathematical statistics (second edition)*, Duxbury, California.
- [4] Balakrishnan, N. and Lai, C.D. (2009). *Continuous Bivariate Distributions*, Springer, New York.
- [5] Bekker, A., Roux, J.J.J. and Arashi, M. (2011). Wishart ratios with dependent structure: new members of the bimatrix beta type IV, *Linear Algebra and its Applications*, 435, 3243–3260.
- [6] Constantine, A.G. (1963). Some noncentral distribution problems in multivariate analysis, *The Annals of Mathematical Statistics*, 34(4), 1270-1285.
- [7] Davis, A.W. (1979). Invariant polynomials with two matrix arguments extending the zonal polynomials: applications to multivariate distribution theory, *The Annals of Mathematical Statistics*, 31, Part A, 465-485.
- [8] Díaz-García, J.A. and Gutiérrez-Jáimez, R. (2010). Bimatrix variate generalised beta distributions, *South African Statistical Journal*, 44, 193-208.
- [9] Ehlers, R. (2011) *Bimatrix variate distributions of Wishart ratios with application*, (unpublished thesis, University of Pretoria).
- [10] El-Bassiouny, A.H. and Jones, M.C. (2008). A bivariate  $F$  distribution with marginals on arbitrary numerator and denominator degrees of freedom, and related bivariate beta and  $t$  distributions. *Statistical Methods and Applications*, 18(4), 465-481.
- [11] Gradshteyn, I.S. and Ryzhik, I.M. (2007). *Table of Integrals, Series, and Products*, Academic Press, Amsterdam.
- [12] Gupta, A.K. and Nadarajah, S. (2004). *Handbook of Beta distribution and its applications*, Marcel Dekker, New York.
- [13] Gupta, A.K. and Nagar, D.K. (2000). *Matrix Variate Distributions*, Chapman & Hall/CRC, Boca Raton.
- [14] Gupta, A.K., Orozco-Castaneda J.M. and Nagar D.K. (2009). Non-central bivariate beta distribution, *Statistical Papers*, 52, 139-152.

- [15] Gupta, A.K. and Wong, C.F. (1985). On three and five parameter bivariate beta distributions, *Metrika*, 32, 85-91.
- [16] Herz, C.S. (1955). Bessel functions of matrix arguments, *Annals of Mathematics*, 61(3), 474-523.
- [17] Human, S.W. and Chakraborti, S. (2010). Q charts for the exponential distribution, *JSM 2010 Proceedings, Section on Quality and Productivity*, Vancouver, British Columbia, Canada.
- [18] James, A.T. (1960). The distribution of the latent roots of the covariance matrix, *The Annals of Mathematical Statistics*, 31, 151-158.
- [19] James, A.T. (1961). Zonal polynomials of the real positive definite symmetric matrices, *Annals of Mathematics*, 74, 456-469.
- [20] James, A.T. (1964). Distributions of matrix variate and latent roots derived from normal samples, *The Annals of Mathematical Statistics*, 35, 475-501.
- [21] Johnson, N.L., Kotz, S. and Balakrishnan, N. (1994). *Continuous Univariate Distributions, Volume 1 (second edition)*, John Wiley & Sons, New York.
- [22] Johnson, N.L., Kotz, S. and Balakrishnan, N. (1995). *Continuous Univariate Distributions, Volume 2 (second edition)*, John Wiley & Sons, New York.
- [23] Jones, M.C. (2001). Multivariate t and beta distributions associated with the multivariate F distribution, *Metrika*, 54, 215-231.
- [24] Khatri, C.G. (1966). On certain distribution problems based on positive definite quadratic functions in normal vectors, *The Annals of Mathematical Statistics*, 37, 468-479.
- [25] Koev, P. and Edelman, A. (2006). The efficient evaluation of the hypergeometric function of matrix argument, *Mathematics of Computation*, 75(254), 833-846.
- [26] Kotz, S., Balakrishnan, N. and Johnson, N.L. (2000). *Continuous Multivariate Distributions, Volume 1: Models and Applications (second edition)*, John Wiley & Sons, New York.
- [27] Libby, D.L. and Novick, M.R. (1982). Multivariate generalized beta distributions with applications to utility assessment, *Journal of Educational Statistics*, 7(4), 271-294.
- [28] Malik, H.J. (1967). Exact distribution of the quotient of independent generalized gamma variables, *Canadian Mathematical Bulletin*, 10, 463-465.
- [29] Mathai, A.M. (1993). *A Handbook of Generalized Special Functions for Statistical and Physical Sciences*, Clarendon Press, Oxford.
- [30] Mathai, A.M., Saxena, R.K. and Haubold, H.J. (2009). *The H-function: Theory and Applications*, Springer, New York.
- [31] Montgomery, D.C. (2009). *Statistical Quality Control: A Modern Introduction (sixth edition)*, John Wiley, New York.
- [32] Muirhead, R.J. (1982). *Aspects of Multivariate Statistical Theory*, John Wiley & Sons, New York.

- [33] Nadarajah, S. and Kotz, S. (2005). Some bivariate beta distributions, *Statistics*, 39(5), 457-466.
- [34] Nadarajah, S. (2009). A bivariate distribution with gamma and beta marginals with application to drought data, *Journal of Applied Statistics*, 36(3), 277-301.
- [35] Ng, K.W., Tian, G. and Tang, M. (2011). *Dirichlet and Related Distributions: Theory, Methods and Applications*, John Wiley & Sons, New York.
- [36] Olkin, I. and Liu, R. (2003). A bivariate beta distribution, *Statistics and Probability Letters*, 62, 407-412.
- [37] Patil, G.P., Boswell, M.T. and Ratnaparkhi, M.V. (1984). *Dictionary and classified bibliography of statistical distributions in scientific work: Continuous univariate models*, International Co-operative Publishing House, Burtonsville, MD.
- [38] Patnaik, J.H. (1949). The non-central  $\chi^2$  and  $F$ -distributions and their applications, *Biometrika*, 36, 202-232.
- [39] Pe, T. and Drygas, H. (2006). An alternative representation of noncentral beta and  $F$  distributions, *Statistical Papers*, 47, 311-318.
- [40] Pham-Gia, T. and Turkkan, N. (2011). Distributions of ratios: from random variables to random matrices, *American Open Journal of Statistics*, 1, 93-104.
- [41] Quesenberry, C.P. (1991). SPC Q Charts for start-up processes and short or long runs, *Journal of Quality Technology*, 23(3), 213-224.
- [42] Rada-Mora, E.A. and Nagar, D.K. (2007). Multivariate generalized beta distributions, *Random Operators and Stochastic Equations*, 15, 163-180.
- [43] Sánchez, L.E., Nagar, D.K. and Gupta, A.K. (2006). Properties of noncentral Dirichlet distributions, *Computers and Mathematics with Applications*, 52, 1671-1682.
- [44] Tang, P.C. (1938). The power function of the analysis of variance tests with tables and illustrations of their use, *Statistical Research Memoirs*, 2, 126-150.
- [45] Tiao, G.G. and Guttman, I. (1965). The inverted Dirichlet distribution with applications, *Journal of the American Statistical Association*, 60(311), 793-805.
- [46] Troskie, C.G. (1967). Noncentral multivariate Dirichlet distributions, *South African Statistical Journal*, 1, 21-32.
- [47] Zantek, P.F. (2005). Run-length distributions of Q-chart schemes, *IEEE Transactions*, 37, 1037 – 1045.