

the  
imagination  
station

a Centre to Inspire & Promote Creativity in  
Newtown, Johannesburg, South Africa

Submitted in partial fulfilment of the requirements for the degree Masters in Architecture [Professional],  
Department of Architecture, Faculty of Engineering, Built Environment and Information Technology,  
University of Pretoria, South Africa, 2013.

submitted by: Bronwyn Fleming

Course Coordinator: Arthur Barker  
Study Leader: Karel Bakker

## dissertation information

---

Full dissertation title:	The Imagination Station: a Centre to Inspire & Promote Creativity in Newtown, Johannesburg, South Africa
Submitted by:	Bronwyn Fleming
Student Number:	10275763
Study Leader:	Karel Bakker
Course Coordinator:	Arthur Barker
Degree:	Masters of Architecture [Professional]
Department:	Department of Architecture
Faculty:	Faculty of Engineering, Built Environment and Information Technology
University:	University of Pretoria,
Country:	South Africa,
Date:	November 2013

In accordance with Regulation 4[e] of the General Regulations [G.57] for dissertations and theses, I declare that this thesis, which I hereby submit for the degree Masters of Architecture [Professional] at the University of Pretoria, is my own work and has not previously been submitted by me for a degree at this or any other tertiary institution.

I further state that no part of my thesis has already been, or is currently being, submitted for any such degree, diploma or any other qualification.

I further declare that this thesis is substantially my own work. Where reference is made to the works of others, the extent to which that work has been used is indicated and fully acknowledged in the text and list of references.

Bronwyn Fleming, November 2013

## project summary

---

**Problem Statement:** As with the majority of Johannesburg areas, Newtown's Electric Power Station Heritage Precinct does not fully realise its potential for spatial relations facilitating creative means of living. Creativity is a powerful tool to engage present and future possibilities. A Centre to stimulate creativity will benefit the direct area users, as well as contributing to the prominence of the historical and cultural richness of Newtown.

**Programme:** Creativity Centre

**Site Description:** The vacant parking space used by Sci-Bono Discovery Centre  
**Site Location:** Corner Bree and Miriam Makeba Streets,  
Newtown Electric Power Station Heritage Precinct,  
Johannesburg City, South Africa

**GPS Coordinates:** S26°12.16' E28°01.59' • 1734m above sea level

**Architectural Theoretical Premise:** *Gesamtkunstwerk*

**Architectural Approach:** Exploration of architecture that loudly expresses the creative programme versus an understated architecture that facilitates the creative programme to make the announcement of a place of and for creative exploration.

**Architectural Outcome:** The design of an understated environment providing spaces for the creative programme to take the lead in creative expression, as opposed to that of a manic architectural statement.

**Client:** South African Department of Arts and Culture

**Funding Partners:** First National Bank [FNB]  
Business Arts South Africa [BASAA]

**Users:** Learners  
Business People  
The General Public

**Research Field:** Heritage and Cultural Landscapes

**Keywords:** creativity centre; art; exhibition; community; Newtown



**SHINE ON, YOU CRAZY DIAMOND:** Comet Ison, dubbed the 'comet of the century', has entered the Earth's orbit. Now visible to the naked eye, it is expected to continue brightening over the next few weeks until it outshines the moon. Travelling at 2 377km/s, it will come closest to the sun on November 28, when it is expected to heat up to 2 760C and provide the greatest celestial display in more than 300 years ● See Page 9

Picture: NASA

thank-you

Mum, Dad, Kuba, Bruce R, Stephen, Jam, Dan, Mitch, Warrick, Lex, Calvin, Bruce C, Werner, Claud, Rudi

thank-goodness it is over

28.11.2013

## abstract

---

As with the majority of Johannesburg areas, the Newtown Electric Power Station Heritage Precinct does not fully realise its potential for spatial relations facilitating creative means of living. Creativity is a powerful tool to engage present and future possibilities. A Centre to stimulate creativity will benefit the direct area users, as well as contribute to the prominence of the historical and cultural richness of Newtown.

The vacant site adjacent to the Sci-Bono Discovery Centre provides an apt location for the Creativity Centre as the intervening programme will activate, strengthen and define the presently underutilised street corner edges. The proposed architectural spaces aim to direct the site's current movement routes created by pedestrian commuters, in order for creativity to become more ingrained in daily life.

The proposed architectural elements aim to facilitate creative activities - both curatorial and organically inspired through community appropriation of specifically designed open, or adaptable, spaces. The Centre aims to become a creative community gathering hub: becoming integral to the existing creative individuals currently pursuing artistic practices in Newtown.

*Gesamtkunstwerk* theoretically guides the project: in terms of the architectural intervention being comprised of singular elements all contributing to a greater whole. *Gesamtkunstwerk* also programmatically unites the entire Electric Power Station city block, through promoting the unification of art forms with life, as a holistic, creative entity.

The Centre acts as a crucial beacon highlighting the importance of creativity in the contemporary South African situation where it is undervalued and underutilised. It also articulates that as a directorial element of societal authorisations and processes, architectural design should articulate the value of creativity through facilitating and inspiring creative modes of living.

# Table of Contents



## 001 reflection introduction

1

<b>01 investigation</b>	4
1.1 Advocation	5
1.2 Problem Statement	
1.3 Large Scale Proposal	6
1.4 Aim of Study	7
1.5 Architectural Hypothesis	
1.6 Project Scope	8
1.7 Relevance of Project	9
1.8 Project Overview	11
1.9 Methodology	12



## 002 the[st]ory conditions

13

<b>01 creativity</b>	16
1.1 Background: The Twenty-First Century Societal Condition	17
1.2 Importance of Creativity and Imagination	21
1.3 The Role of Architecture	26
1.4 Programme	28
1.5 Programmatic Components	29
1.6 Programmatic Details	33



<b>02 players</b>	38
2.1 Client	39
2.2 Funding Partner	40
2.3 Management Partner	
2.4 User	42
2.5 Architectural Intentions	43
<b>03 cultural landscape</b>	46
3.1 Introduction	48
3.2 Johannesburg Inner City Urban Context	
3.3 Cultural Arc	49
3.4 Greater Newtown Urban Context	52
3.5 Newtown Precinct	55
3.6 Newtown Electric Power Station Heritage Precinct	60
3.7 Selected Site	68
3.8 Mapping	72
3.9 Theoretical Urban Response	77
3.10 Proposed Framework	80
3.11 Theoretical Architectural Response	84
3.12 Programmatic Architectural Response	86

## 003 experimentation design

87

<b>01</b> design problem	90
1.1 Introduction	92
1.2 Architectural Theory: <i>Gesamtkunstwerk</i>	94
1.3 Precedent Study	111

<b>02</b> design development	115
2.1 Introduction	
2.2 Design Generators	
2.3 Conceptual Approach	
2.4 Design Development	117
2.5 Place of Exchange Typology: The Precedence of a Market	121
2.6 Design Development Continued	134

<b>03</b> design outcome	140
3.1 Introduction	139
3.2 Urban Response	
3.3 Zones	147
3.4 Programmatic Articulation	139
3.5 Drawings	150

<b>04</b> technical development	166
4.1 Introduction	167
4.2 Technical Concept	
4.3 Technical Approach	168
4.4 Concept Diagram for Each Zone	170
4.5 Precedent	171
4.6 Material Palette	173
4.7 Material Study	
4.8 Structural Systems	175
4.9 Introduction to Passive Strategies	179
4.10 Lighting	180
4.11 Heating, Cooling, Ventilation	183
4.12 Planting	186
4.13 Construction Technology	187
4.14 Specifics	188
4.15 Models & Presentation	193



## 004 experience conclusion

197

<b>01</b> end or beginning	200
Sources	203
List of Figures	207



## i·mag·i·na·tion

“Just as an individual person dreams fantastic happenings to release the inner forces which cannot be encompassed by ordinary event, so too a city needs its dreams.”

(Alexander, Ishikawa & Silverstein, 1977:298)



introdu

■ 001 reflection

unction



1.1 Advocation 1.2 Problem Statement 1.3 Broad Scale Proposal  
1.4 Aim of Study 1.5 Architectural Hypothesis 1.6 Project Scope 1.7 Relevance of Project  
1.8 Project Overview 1.9 Methodology

# 01 investigation

## 1.1 Advocation

### Creativity Centre

A Centre that promotes and facilitates creative exploration and generation will enrich and strengthen Newtown's Electric Power Station Heritage Precinct, while acting as a point of urban acupuncture for creativity to flow into Johannesburg city.

Such a facility articulates the need for architecture to respond to the programmatic agenda of highlighting the latent potential of individual imagination and creativity, as well as the importance of cultural heritage; which is predominantly undervalued by contemporary Twenty-First Century, South African society.



Figure 1: The addition of a missing layer to Newtown's Electric Power Station Heritage Precinct

## 1.2 Problem Statement

### The case of Newtown's Electric Power Station Heritage Precinct providing the impetus

#### Large Scale Problems

The Newtown Electric Power Station Heritage Precinct (EPSHP) displays two distinct problems commonly present in the majority of contemporary South African spaces:

1. The positive and negative spaces - resulting from architectural implementation - do not facilitate imaginative modes of living, expression or appropriation.
2. The potential of many spaces are not fully understood or utilised.

Newtown's more recently implemented urban design schemes have cleaned up the precinct, but left it somewhat hollow and overly sanitised. A new layer of creative energy embodied in architectural interventions and programmes needs to enrich Newtown's cultural historic backbone to a greater degree.

## 1.3 Large Scale Proposal

---

### Newtown's Public Buildings

Additionally, it is problematic that in such a publicly orientated cultural heritage precinct, the public buildings are unyielding, solitary edifices that do not contribute or open their programmes up to their immediate surroundings. Since their programmes are so internalised, their lessons are cut off from the external environment and are not part of common public understanding or existence. This is detrimental to contemporary understanding of culture and heritage, as the building's programmes do not seep into the subconscious of the area's commuters, users and residents. Instead of offering richness, the public buildings quickly become seen as exclusive and elitist - as their depths are unknown. Such is the case with many of the Newtown Park users, who were unable to explain what the Sci-Bono Discovery Centre building housed [Author, 2012:(discussion)].

### Porosity

The newly proposed space aims to be porous, with its lessons advancing its user's everyday understanding of the world - in order to set a new, more accessible, architectural model for Newtown's Electric Power Station Heritage Precinct (EPSHP). It is understandable that the existing buildings sought to be robust and vandal-proof to resist boundary fences. New public buildings should be designed to be more integrated and breathe out their programmatic teachings into the public domain.

### Proposed site intervention

The EPSHP's North-Easterly corner, currently Sci-Bono's parking space, presents a major opportunity for completing the perimeter spaces around the park to strengthen the entire cultural city block. Current foot traffic can be captured and sub-consciously incorporated into the programmatic agenda of the new proposed space. The everyday lives of the current cultural precinct users and projected future users are thus enriched.

### Proposed Programme

The building is thus to express the relevance of creativity and imagination in everyday life and business activities by acting as a facility to stimulate creativity and imagination.

The community of EPSHP buildings will benefit by their combined cultural programmes being added to and united through the theory of *Gesamtkunstwerk*. While the EPSHP currently includes a scientific discovery centre; dance studios; a worker's museum and traditional South African cuisine restaurants, it is seen that a facility which relates more directly to creativity will aptly complete the city block as a 'cultural engagement core'.

## 1.4 Aim of Study

The study aims to explore:  
The designing of a place to articulate the importance of creativity in contemporary society.

- The study intends to result in:

1. The design of a place that responds to, supports and encourages the programmatic needs of a Creativity Centre as set out in Chapter 002.
2. The strengthening of Newtown's Electric Power Station Heritage Precinct, both programmatically and spatially.

## 1.5 Architectural Hypothesis

The Architectural Design aims to explore:

1. Whether a greater 'sense of place' for Newtown's EPSHP will be created by utilising the currently under-utilised parking space - as a complementing facility to the public SciBono Discovery Centre.
2. How a space can be a beacon of creative inspiration. This results in exploring whether the architecture acts as a blank canvas to promote programmatic creative agenda; or if the architecture should articulate and embody creativity itself. Alternatively, achieving a middle ground between 'blank canvas' and architectural articulation of the creative agenda might be seen to be best.
3. The breaking down of traditional architectural boundaries and thresholds to enforce a new creative agenda merged with life. Such an exploration may lead to a fragmented architectural product, or alternatively, result in the inclusion of relevant traditional architectural boundaries and thresholds.

4. Architectural notions of a public facility and privacy thresholds therein.

5. How compatible mixed-uses function best together.

6. Whether the proposition of such a built facility will in fact make a difference in articulating the importance of creativity as an everyday phenomenon and architectural spaces that foster creativity in society. - As with the example of projects in the city of Barcelona, Spain, becoming the first point of creative urban acupuncture heralding the start of architecture expressing an imaginative spirit and creative modes of living.

## 1.6 Project Scope

---

### Framework

The Framework for the Imagination Station takes note of past frameworks for the Entire Newtown Precinct proposed by GAPP Architects and Urban Designers. The proposed framework, however, limits its boundaries to the more direct area of Newtown's Electric Power Station Heritage Precinct, to which the site contributes.

### Site

The proposed design responds to the existing lone concrete cooling tower on its Southern boundary. The design proposes a fitting use for the structure in order to contribute to the framework. The design does not, however, go into deeper design investigation other than proposing the building use.

### Design & Technical Resolution

As the project ended up being substantial in size, the design is resolved with greater focus on its primary aspects relating to its main programmatic contributions.

### Project Time Frame

The time frame for exploring the project is limited until November 2013.



## 1.7 Relevance of Project

---

The project contributes to:

### 1. A strengthened understanding of Newtown's Electric Power Station Heritage Precinct

Strengthening the user's understanding of the richness and significance of Newtown's cultural heritage is important because if users are unaware of the history of such areas, as well as that of their personal heritage, they cannot expect to fully identify with or embrace the richness of and meaning in their present moment existence or completely connect with their future aspirations. Their sense of empowerment from such knowledge is therefore lost. "People cannot maintain their spiritual roots and their connections to the past if the physical world they live in does not also sustain these roots" [Alexander et al, 1977:132].

Cultural critic Fred de Vries [2010:(lecture)] aptly discusses this point in his analysis of individuals living in Johannesburg's newly gated communities. Such individuals are seen to lose their community ties and understanding of their personal cultural heritage due to being cut-off from their family heritage. de Vries states how such individuals therefore become unrooted and lost in the predominantly materially-obsessed, homogeneous society of the contemporary era.

### 2. Adding to the typological understanding of a contemporary Creativity Centre in the South African context

The typological model of a Creativity Centre has not been insightfully explored in contemporary South African architecture; especially in relation to contemporary overseas precedents. The project therefore provides a valuable South African precedence.

### 3. Promoting awareness for the importance of creativity and imagination

The proposal commences debate at the academic level for the importance of creativity and its consistent undermining in contemporary society and how architecture can relate to promoting creative means of existence. Such debate acts as a catalyst in prompting action in the greater realm of the built-environment and practicing architectural sphere.

### 4. Drawing awareness to the inadequacy of the majority of current South African architectural offerings in inspiring and facilitating imaginative means of living

The project raises the issue that present contemporary architectural offerings do not adequately facilitate creative means of living. Contemporary architecture needs to re-explore and re-interpret the definition of contemporary architecture - as spatial creation reflecting the

---

society of the time; and what design should encourage and mould society to be. Spaces do not necessarily have to be fully enclosed and rigidly finalised. Many best practice spaces are appropriated by users and grow organically [Alexander *et al*, 1977:350] - as illustrated by *Figure 11* on page 25 - 'Shack Rise' by Daniel Maggs [2010].

### 5. Providing a place for creative individuals to congregate, feel safe and further their creative ideas and expressions

Registered Psychologist Janet du Preez [2012:(interview)], outlines how creative individuals are sidelined by the schooling system dominated by the preoccupation with academic and sporting achievements; as well as being sidelined by greater society as creative individuals are often perceives as 'eccentrics' not adhering to 'societal norms'. As a result, true creative people often experience low self esteem. The establishment of a Centre for

Creativity enforces the importance of creative self identity, while giving a place of refuge for creative people to meet with like-minded individuals and forge a strengthened collective identity.

The architectural implication and translation of this factor progresses towards designing and providing a place that makes the individual feel valued and psychologically, socially and physically safe to be creative. When individuals feel accepted and safe, they are able to express their creativity, which leads to self-growth and satisfaction [du Preez, 2012:(interview)].

## 1.8 Project Overview

---

### *What*

Proposal for a Creativity Centre.

### *Where*

Utilising the gravel-chip parking site used by the Sci-Bono Discovery Centre; situated in Newtown's Electric Power Station Heritage Precinct in Johannesburg city, South Africa.

### *How*

The theory of Gesamtkunstwerk is utilised to guide the project.

### *Who*

Initiated by the South African Department of Arts and Culture.  
Funded by First National Bank [FNB]. Managed by Business Arts South Africa [BASA]. Catering to adolescents, young adults and the general public.

### *Why*

1. The Electric Power Station Heritage Precinct requires unification.
  2. Creativity needs to be articulated as an important component of daily existence.
  3. Architecture should promote and facilitate creative modes of living.
  4. The project acts as precedence for future projects of a similar nature and typology to be debated and proposed in South Africa.
  5. The user's perceptual world view is seen to be stimulated in alternative ways by such creative experimentation and application.
- Different ideas and altered mind sets to daily occurrences or problems with which users were struggling preceding their experience and involvement in the facility, are realised.



Figure 2: Kolb's Methods of Learning: | reflection | theorisation | experimentation | experiencing | [Author, 2012]

## 1.9 Methodology

### Outline

The approach to the project deals with three distinct phases:

- [A] beginning with information assimilation and analysis to direct project decisions;
- [B] progressing to project design through working with the gathered information;
- [C] after which the resultant design can be analysed for hypothetical conclusions.

### Phases

#### [A] Preparatory Phase

1. Mapping is undertaken from the larger urban context down to the existing site conditions.
2. A framework for the EPSHP is put forward after analysing past proposals by GAPP Architects - to which the design can respond.
3. The programmatic components are explored.
4. Appropriate theoretical models are explored for application.

5. Suitable precedents are analysed for lessons that can be learned and applied.
6. A conceptual design approach is developed.

Each exploration leads towards generating specific architectural responses that progress into the design phase.

#### [B] Design Development Phase

7. Design Development
8. Examination of further precedents
9. Furthering of Design Development.
10. Technological Development: commencing with technological concept; precedents; materiality; structure; systems; detailing
11. Design Resolution

#### [C] Recapitulation Phase

12. Conclusion to Hypothesis

### Detail Explanations

#### Mapping

The urban context is mapped in terms of existing physical and transient aspects. The employed mapping techniques included drifting; map layering; participant observation; participant interviewing; and systematic observation over time.

#### Kolb's Methods of Learning

According to the psychological theory of Kolb's Methods of Learning, learning is seen to develop through four cyclical phases. The phases are: reflection, theorisation, experimentation and experiencing [du Preez, 2012:(interview)]. These phases are explored as a methodology in terms of the four sectional chapters of the dissertation, as well as being accommodated by the building's programme and the architectural design response.

condi

■ 002 the[st]ory

tions

1.1 Background: The Twenty-First Century Societal Condition  
1.2 Importance of Creativity and Imagination 1.3 The Role of Architecture  
1.4 Programme 1.5 Programmatic Components 1.6 Programmatic Detail

# 01 creativity

# 1.1 Background: The Twenty-First Century Societal Condition

## The Snowballing Situation

### What is Valued

Twenty-First Century global society has become characterised by a preoccupation with material gain; profit; items of quantifiable value; instant gratification and the commodification of goods and service [Hyde, 2007:365]. As Enn Ots [2011:48] states - it is widely implied that the contemporary goal in life is to “die with the most stuff.” Such a consumer mentality overrides aspects of life that are of substance and value.

## Technological Driver: giving or taking?

As with former epochs, technology continues to change the way and means individuals relate to their worlds; and what comprises those worlds and how they are constructed. The Third Industrial Revolution - epitomising the Twenty-First Century - has created a volatile world dominated by virtual information, connections and interactions. The speed of information transfer reached new frontiers at the beginning of the early Twenty-First Century with virtual communication and ‘smart’ feature applications. Ots [2011:48] describes contemporary humanity being consumed by an ‘information orgy’ with an unconquerable, ever-increasing pile of ‘chatter’ interfering with balanced modes of existence.

## Smart[phones] facilitating Smart[people]?

With such universal access of information, the world has become homogenous even in its ‘counter-movements’. Social networking has propelled the world of the virtual to a dangerously narcotic level; with the viral spread of virtual communities. Such fake communities infringe on the place of real-world societal communities, who historically hold the role of uniting and giving meaning to individual existences.

Figure 3: Increased speed of technological progression [Author adaptation from Kruger, 2011]

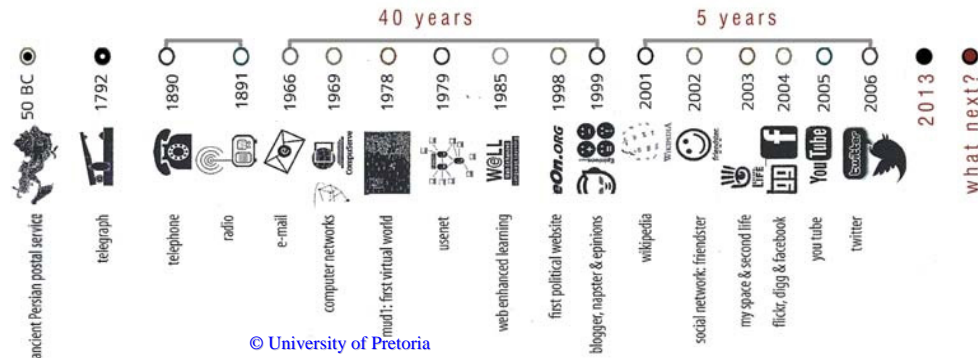



---

## Result: technology overwrites worlds<sup>1</sup> of substance

Virtual communities infringe on the built environment through not maintaining tangible links with particular places [Deleuze in Ots, 2011:27]. The youth are increasingly trapped in this pseudo straitjacket that unsympathetically engulfs them with generic societal preoccupations: such as popularity ratings and the importance of aesthetic and social appearances, while erasing the sensual richness of real world. It is the age of the generation who live for the present moment, while holding little regard for the past or future. Advertising has only exacerbated these factors: playing on and promoting what is seen to be of value in material society. Worlds of substance, found in reality and creative imaginings are thus undermined.

---

footnote 1: 'worlds' as there is the real, tangible world; and other worlds of value derived from human imagination

Individuals live under a false impression of what is of true value

Individuals become so disorientated in oscillating between virtual and real worlds that they forget which worlds encompass true value and satisfaction. As the current generation of children grow up, the technological world will increasingly dominate their existence. It will become increasingly difficult for the youth to differentiate between the worlds of substance and that of mass-consumed, mentally- and physically-disruptive noise.

### Lost heritage; Lost individuals

The deterritorialised society [Deleuze in Ots, 2011:78] does not accommodate ways for individuals to connect with the intrinsic parts of their unique heritage and identity. The entire world acts as their homogenised 'community'. They are everywhere, yet nowhere, at the same time. Fostering of meaningful interaction and contributions to their contexts are therefore lost; as with the in-depth level of support of traditional communities.



Figure 4: The aerial view of a secure estate in the suburb of Fourways, Johannesburg, South Africa. Such an image aptly illustrate the loss of identity and cultural heritage in portions of contemporary society [Google Earth, 2012]



Figure 5: Leonardo da Vinci's polymath workings



Figure 6: Phoenix College Principle Moyo states that parents of the Semi-Private school are not interested in cultural education for their children as it is not seen to help them become University-trained Professionals [Author, 2012]

## Creativity and imagination are under valued, sidelined and underutilised

The frenetically paced, virtually-driven world does not include or prioritise moments for imaginative dreaming or creative appropriation. Individuals are so busy doing, that they do not give themselves time to think more creatively in the present or about the future. Busy adults utilise technological gadgets such as play stations and televisions to keep their children easily amused - instead of promoting activities such as reading and external environment explorations that will provoke a child's imagination and stimulate their own unique thoughts [du Preez, 2012:(interview)].

Such a mentality is in contradiction to past eras such as the Renaissance where society saw the importance of combining science, art and philosophical reflection for a total learning and holistic output. Such is exemplified by Leonardo da Vinci: whose work transcends science; mathematics; engineering; art; architecture; music; geology; botany and anatomy to name a few of his investigated disciplines.

## The South African Relation

The majority of underprivileged schools do not offer cultural education, such as drama and art classes as there is little parental demand for such subjects that are not perceived to make a valuable educational contribution [Principle Moyo, 2012:interview]. Parents of underprivileged children want their children to improve their circumstances; such that emphasis is placed on their children matriculating with the logically-based subjects of mathematics and science; such that their children can attend university and become professionals. This is detrimental to the development of such children as story telling; a comprehensive understanding of their cultural and historical identity; and furthered utilisation of their imaginations for future possibilities are lost.

---

## Outcome

### Individuals seek escapism

In order to cope with their incomprehension, lack of control and meaningful connections between the physical and worlds lacking substance, individuals turn to means of escape. Such distractions take the form of films, theme-park visits, drugs, smoking and alcohol-use to relieve tensions.

### The resultant role of creativity

In response to the problem of distracting constructions of the real world, it is argued that creativity and imagination can provide priceless escapes of worth, meaning and substance. Individual's and community's lives are therefore infused with more creative possibilities as well as a more rewarding present existence.



Figure 7: Imagination can lead individuals to change their circumstances [Fletcher, 2001]

## 1.2 Importance of Creativity and Imagination



Figure 8: 'Imagination is everything' - Albert Einstein [in Viereck, 1930:372] [Fletcher, 2001]

### Introduction

Albert Einstein [in Viereck, 1930:372] outlines the importance of imagination, stating that imagination "is everything"; "more important than knowledge. Knowledge is limited. Imagination encircles the world"; and "the preview of life's coming attractions." Creativity and imagination are predominantly undervalued in volatile contemporary society due to their unquantifiable means.

As Joseph Conrad [in Hyde, 2007:198] states, creativity's "...appeal is made to our less obvious capabilities: to that part of our nature which, because of the warlike conditions of existence, is necessarily kept out of sight within the more resisting and hard qualities - like the vulnerable body within a steel armor...The artist appeals...to that in us which is a gift and not an acquisition - and, therefore, more permanently enduring. He speaks to our capacity for delight and wonder, to the sense of mystery surrounding our lives; to our sense of pity, and beauty, and pain; to the latent feeling of fellowship with all creation

- to the subtle but invincible conviction of solidarity that knits together the loneliness of innumerable hearts, to the solidarity...which binds together all humanity - the dead to the living and the living to the unborn."

Creativity and imagination are not only about individual realisation, but also contributes to business and creative, design economies.

### Importance of Creativity for Specific User Groups

#### In Business

An IBM Study of 2010 [IBM:(online)] lists creativity as "The Most Important Leadership Quality for CEOs", as found in one-on-one CEO interviews of 1,500 corporate heads and public sector leaders across sixty countries and thirty-three industries. Business innovation is the contemporary buzzword, with certain businesses themselves being works of art propelled by imagination and creative, alternative ideas.



Figure 9: 'Everything you can imagine is real' - Pablo Picasso: Imagination's ability to transform circumstance [Ryal, 2010]

Creative imagination is beneficial for business's in terms of:

- business's being able to re-invent themselves, change and adapt in terms of organisational development
- business strategy
- product development
- corporate responsibility in terms of producing better, more sustainable products
- pushing new business paradigms
- unleashing people's innate creativity to make workers more productive
- re-engineering processes for more effective and efficient business operations [du Preez, 2012]

### In assisting low socio-economic users

Einstein's well-know quotation continues by stating: 'Logic will get you from A to B. Imagination will take you everywhere.' This is particularly important in terms of the South African third-world condition, exemplified

by the desperate circumstances of current Newtown users; as stimulating such users to unleash their imaginations for improving their situations is the first step in bringing about change. As George Bernard Shaw [1921:Part I: Act II:32] states: "Imagination is the beginning of creation. You imagine what you desire, you will what you imagine and at last you create what you will."

### In educational development

Creative imagination is an important factor in an individual's educational development as it:

- teaches thinking skills, constructive engagement and teamwork
- is entertaining, while creating self-worth through displaying to a learner his/her inherent and latent creative talents.



Figure 10: The differences between utilising one's imagination versus being a sponge to generic societal chatter are pronounced [Author, 2012]

## Importance of Creativity for General Society

### Creativity as a way of life

Creativity is important in terms of general everyday living for the wider public body as it induces:

- broad-thinking individuals who are less judgmental and closed-minded, such that a more harmonious society with greater acceptance is fostered: "it widens out the boundaries of our being, and unites all living things" [Pablo Neruda in Hyde, 2007: 368]
- more awareness, presence and thought, which leads to greater empathy with other people and environmental issues, as well as greater willingness towards other people's needs
- positive psychology, possibility thinking and appreciative inquiry where individuals see the good aspects of elements, which leads to creating greater opportu-

- nities for themselves [du Preez, 2012]
- free-thinking individuals; de-programmed from contemporary generic societal 'sheep mentality'
- greater personal fulfillment as an individual's soul is satisfied by having solved a problem through his or her own idea initiations
- resourcefulness and learning to generate alternatives: as a plethora of solutions and possibilities become available to filter and edit

### Creativity and imagination as links that bind humanity

Creativity bridges beyond age and race, such that it possesses the ability to unite disparate factions. Creativity links all organisms in the world for an improved holistic outlook: "that communion by which we are joined to one another, to our times, to our generation, and to the race" [Hyde, 2007:74] Creativity allows individuals to offer more than given to them. As Lewis Hyde [2007:253] states,

---

creative imaginers are “drawn into a life higher than that to which they have been born. Bestowed from the dead to the living and from the living to the unborn, our gifts [of creativity] grow invisibly among us to sustain each man and woman above the imperfections of state and age.”

Creativity causes individuals to feel part of a community and something greater than their single egotistical self. It is the egotistical self that brings about destruction to the environment and other beings.

As Hyde [2007:197-8] states: “...the commerce of art draws each of its participants into a wider self. The creative spirit moves in a body or ego larger than that of any single person. Works of art are drawn from, and their bestowal nourishes, those parts of our being that are not entirely personal, parts that derive from nature, from the group and the race, from history and tradition, and from the spiritual world. In the realized [s/c] [creative] gifts of the gifted we may taste that *zoë-life*<sup>1</sup> which shall

---

<sup>1</sup> “[Greek Origin: *dzo-ay*’]: the state of one who is

not perish even though each of us, and each generation, shall perish.”

New thinking  
and a means to keep learning at any age

Creativity provides fresh, alternative perspectives to problems, such that improved quality and quantity of solutions are realised:

“The principle goal of education is to create men who are capable of doing new things, not simply of repeating what other generations have done - men who are creative, inventive and discoverers” [Jean Piaget in Jervis and Tobier, 1987:30].

---

possessed of vitality or is animate; of the absolute fullness of life, both essential and ethical; life real and genuine, a life active and vigorous, blessed” [Pearsall, 1999]

Such a thought has been re-iterated by numerous thinkers over the years, as with Chrisna du Plessis [2004:13] stating that a new paradigm must be thought into existence in order to overcome the environmental crisis, as an example.

Self-discovery

Creativity offers a means for self-discovery with individuals being able to tap into their inherent self; away from critical society. Creative endeavours offer adults a therapeutic space to enjoy their own talents away from worldly burdens.



Figure 11: 'Shack Rise' by Daniel Maggs illustrates an underprivileged community creatively and organically adapting an abandoned structural frame for their own means: "celebrating the potential of the human and creative spirit. It stands in counterpoint to the subsidised wastelands the South African Government is building for the poor and the endless tracts of bland, middle-class suburbia" [Cooke, 2012].



## 1.3 The Role of Architecture

---

### Architecture as a facilitator of creativity and imagination

1. As an element that shapes human possibilities and actions [Churchill<sup>1</sup> in Johnson, 1994: 269], architectural design should pronounce and foster a culture of creativity. Spatial design therefore needs to contribute to creative mind sets, cultural expression and appropriation by its users.
2. Education needs to accommodate more experiential learning. As shapers and facilitators of experiences, architecture needs to be mindful of this factor.
3. The architectural agenda must encompass the promotion of worlds filled with and fostering true meaning and inherent value; over psychotic virtual worlds. Designs therefore need to enforce *genius loci* [Martin Pawley in Ots, 2011:53]. As Ots [2011:52] states, “If the environmentalists prevail, architecture may once again be restored to a higher level of value than that of the commodity.”

---

<sup>1</sup>“We shape our buildings; thereafter they shape us.”

4. A society is reflected through its architectural edifices. Architectural designs must be founded upon integrity in order to promote a society of integrity.

### Current status of South African architecture and the profession

The author views many South African built-environment projects as lacking design integrity and full engagement with the location and programmatic opportunities. Hasty, ill-explored, -conceived and -executed designs are thus implemented in many architectural firms’ rush to move on to the next project for further material gain. The possible meaningful facilitation roles that architecture could promote in society are lost, such that designs do not create value in the lives of their users.

Ots [2011:138] describes the architectural realm as being overridden by ‘flashy junkspace’ for the ‘throw-away society’. The author sees the majority of current built environment projects reinforcing and promoting the rise of technology and virtual worlds instead of relating to elements of substance that draw individuals back to an understanding of the intrinsic aspects of value in life. In contemporary South African society, the

author also perceives that the value of a qualified architect is not fully comprehended in the public domain. Instead, the profession is being usurped by developers, technicians and public individuals [Rich, 2009:(lecture)]. South African architectural design therefore needs to articulate its valuable contribution to the built environment through designs of integrity that facilitate creative means of existence.

### Normative Stance

Architecture has a crucial role to play in facilitating and promoting creative modes of living. Architectural design does not currently fully act upon such a powerful position.



Figure 12: The programmatic precedence of the week-long Burning Man festival in Nevada's Black Rock Desert, United States of America. The annual festival can be seen as the ultimate expression of radical creative practice; where a community fully engages in bringing each individual's talents to the communal pool to generate a more profound output through their collective engagement [London, 2012]

## 1.4 Programme

---

### Introduction

The Creativity Centre's Programme aims to engage current creative activities from the chosen site's precinct; while adding a deeper, spatially curatorial layer to such organic activities.

### Spatial Outline

#### Hall

The Hall offers a large open volume for appropriation as seen fit by artists for experiential installations, exhibitions or as an enclosed meeting facility.

#### Studios

The creative programme encompasses set facilities, including studios for medium to small scale artistic residency practitioners; and work and retail display spaces for permanent artisan's to hire on a monthly basis.

#### Experimentation Centre

The Experimentation Centre houses creative play equipment and facilities for creative experimentation. The venue is seen to generate outputs in terms of creativity being explored and ideas and physical realisations being produced as a result.

### Adaptable Spaces

Curatorial areas offer adaptive spaces for changing exhibitions or facilitated activities changing as stipulated according to the Centre's programmatic needs. Such spaces can be programmed to stimulate creativity.

Organic, adaptable areas for appropriation allow the direct users of the precinct as well as further a-field visitors to direct their visions for engaging with the Centre, its users and community.

### Social Melting Pot

The Centre aims to act as a melting pot for creativity: with inviting social spaces for relaxation and discussions such that it becomes a welcoming community venue. Its creative programme can thus subconsciously infiltrate into people who come to enjoy the venue for its additional community offerings or simply walk through its activity nodes as a route in their daily commute to and from the inner city.

### Service Backbone

The Centre and creativity programme is orchestrated by a management and service backbone; while also offering accommodation to the facilitated artists in residency. Service spaces include foyers and break away rooms.

### Mixed-use

In order to sustain a lively atmosphere, the mixed-use nature of the Centre is furthered with community facilities including cafes and courtyards - shaded and sunny - to encourage community engagement and passers by to linger and become draw into the creative programme and consciousness of The Imagination Station hub.

As Hyde [2007:200] reiterates, 'creativity is commonwealth', with the architectural design aiming to accommodate both the individual and the collective means for creative exploration and expression. The spaces are explored in more detail both individually and in terms of their collective relations to one another before lessons from Christopher Alexander *et al's A Pattern Language* [1977] are explored in *Chapter 03-3.11 Architectural Response*

## 1.5 Programmatic Components



Figure 13: Dot Appropriation Room [Colossal, 2012]

### [A] Creative Spaces

#### Set Facilities

##### 1. The Experimentation Centres

Design facilities to accommodate the following activities which induce creativity [Ots, 2011:62]:

- Making spaces: painting; making; modelling.
- Experimentation spaces through visual illusions, mirrors and cameras etc that engage questioning: disassembling objects distorting perceptions, exaggerating, playing extremes, inverting, inside out, upside down, reversing directions and defamiliarisation.
- Visual apparatus inducing analogies, metaphors; symbolism, systematic analysis, brainstorming, the superimposition and bisections of related ideas; asserting the opposite; alternative ways of looking at particulars.



Figure 14: Experimentation Centre activities [Colossal, 2012]

## 2. Artistic Residency Practitioners Studios

- Sinks; floor drains; hard wearing floors.
- Cores offer built-in-cupboards, desks etc.
- Communal kitchenette.
- Central working space doubles as small exhibition venue when cleaned.
- Soft southern light preferred.

## 3. Permanent Artisan Studios

- Work and retail display spaces.
- Monthly lease.
- Sinks; floor drains; hard wearing floors.
- Cores offer built-in-cupboards, desks etc.
- Communal kitchenette.
- Central space as a more intimate exhibition volume/lecture venue
- Soft southern light preferred.



Figure 15: Experiential Installations in the Hall  
[Colossal, 2012]

## Adaptable Facilities

### 1. Idea Interchange

- A framework that provides possibilities for changeable installations, with detachable components that can roam free from the framework structure and thus create a dialogue with the urban context.

### 2. Hall and Linking Spaces

- Adaptable for changing exhibition volumes and corridors.

### 3. External Courtyard Deck

- Social meetings, discussions, performance, interactions.
- Areas for relaxation.
- Deck installations changed according to Centre's needs.



Figure 16: Installations in the Hall and Linking Spaces [Colossal, 2012]



Figure 17: External Landscaping [Colossal, 2012]

## [B] Social Spaces

### 1. Food Relation

- Healthy food plays an important role in maintaining a healthy, creative outlook [du Preez, 2012(interview)], such that the Cafes and small scale street stalls are seen to provide nutritious offerings that users can enjoy in the venues or external surrounds.

### 2. External Courtyard Deck & Landscaping

- Social meetings, discussions, performance, interactions.  
- Areas for relaxation.

## [C] Service Spaces

1. The Imagination Station Reception.
2. Building Foyers.
3. Hall Breakaway Rooms.
4. The Imagination Station Management.
5. Artist Residency Accommodation.
6. Maintenance, Systems & Services.
7. Horizontal & Vertical Circulation.







## 1.6 Programmatic Details

### [1] Schedule of Accommodation

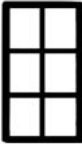
Spacial Typology	Size (m <sup>2</sup> )	Spacial Typology	Size (m <sup>2</sup> )	Spacial Typology	Size (m <sup>2</sup> )
[A] Creative Spaces		[B] Social Spaces		[C] Service Spaces	
• Set Facilities		1. Food Outlets	450	1. Reception	50
1. Experimentation Hall	500	2. External Courtyard Deck	500	2. Foyers:	
2. Artistic Residency Studios	200			- Centre Entry	200
3. Permanent Artisan Studios	200			- Hall	100
• Adaptable Facilities				- Experimentation Hall	100
1. Idea Interchange	250			3. Hall Breakaway Rooms	200
2. Hall	200			4. Management	200
3. Play Plaza	100			5. Artist Residency	200
				6. Maintenance & Systems	
				- Hall	350
				- Artists	550
				- Experimentation Hall	200
TOTAL:	1500		950		2150

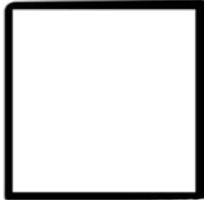

[2] Components

• Characteristics • 1word • Name • Diagram •						
						
	• <b>Artisan's collective</b>	• <b>Artist's collective</b>	• <b>Hall</b>	• <b>Experimentaion Hall</b>	• <b>Idea Interchange</b>	• <b>Food Outlets</b>
	• bee hive	• ant colony	• volume	• facilitator	• free agents (jelly fish)	• service providers
	• introverted workings combining for mutual, combined benefit	• solitary tasks contributing to singular group identity	• light, airy singular volume to be appropriated as required per artistic vision	• functional spaces providing for activity instillations	• collecting and disseminating imagination	• fueling minds for best creative endeavours
	•	•	•	•	•	•

[3] Relations | Proximity | Linkages

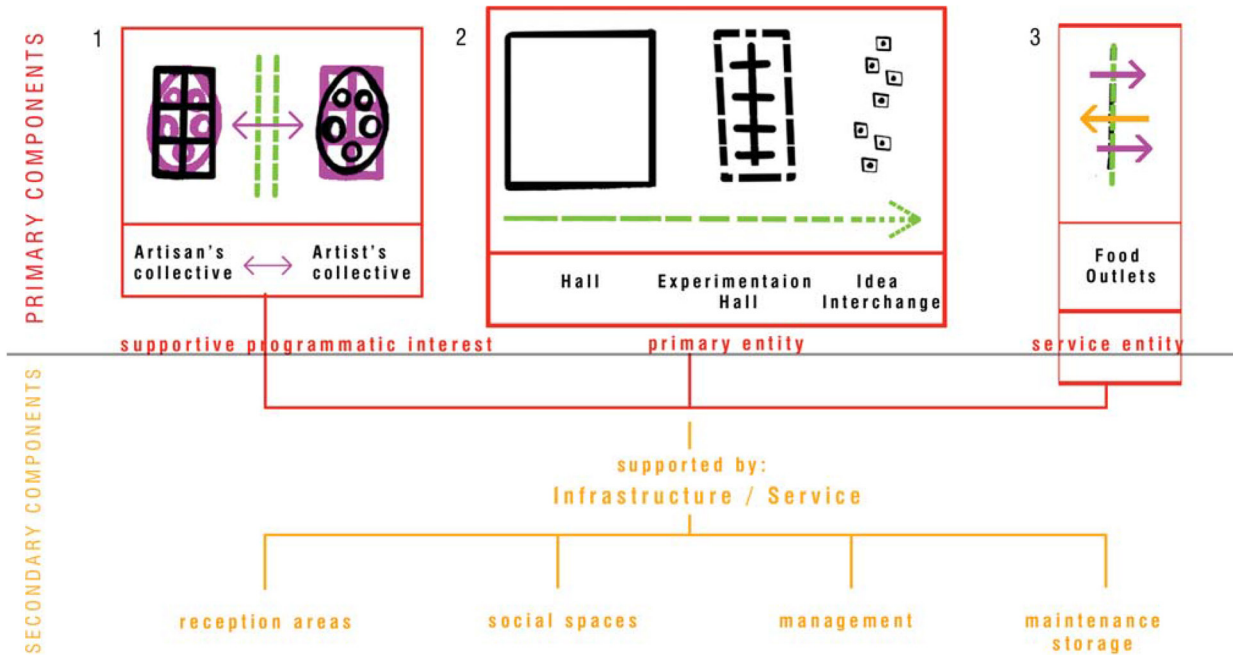

## [4] Infrastructure & Service Cores

### Served and Servant Spaces

Service spaces are positioned to divide the building up programmatically. Servant spaces are seen as cores that house generic services such as ventilation, plumbing and sewerage riser ducts, as well as toilets, store rooms and vertical circulation systems.

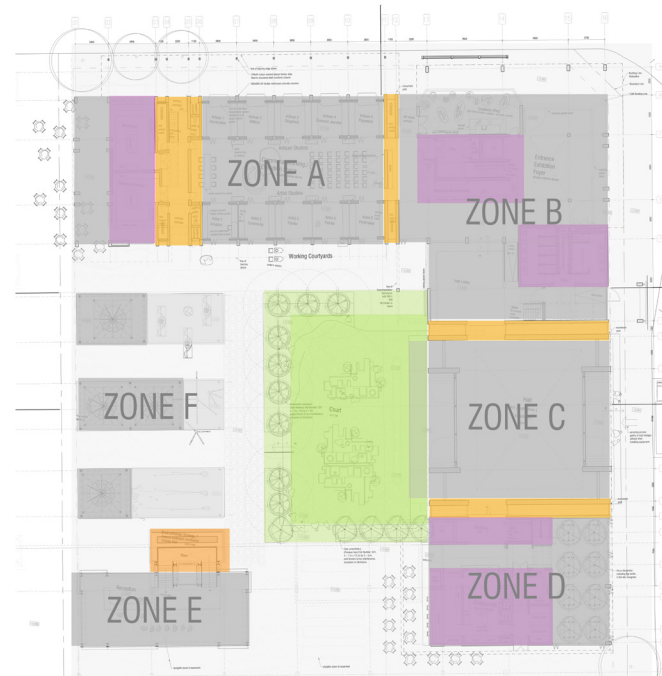

Figure 18: Served and Servant Spacial Zones for the site. Pink areas house Cafe Kitchens, vertical circulation and toilets, while orange areas house horizontal servicing corridors or riser ducts. The service areas divide the programmatic areas into Zones A to D in the main building [Author, 2013]

2.1 Client 2.2 Funding Partner 2.3 Management Partner 2.4 User 2.5 Architectural Intentions

## 02 players

## 2.1 Client



### arts and culture

Department:  
Arts and Culture  
REPUBLIC OF SOUTH AFRICA

#### Introduction

The client for The Imagination Station is The South African Department of Arts & Culture [DAC].

#### Programmatic Compatibility

Such a creative facility as The Imagination Station falls into the DAC's vision of developing "South African culture to ensure social cohesion and nation-building" [DAC, 2012:(online)]. The proposed facility also falls into the department's mission to encompass the development and promotion of arts and culture in South Africa; with the added outcome of enhancing social development" [DAC, 2012:(online)].

The Imagination Station is also relevant in terms of the DAC's concerns for improving the "economic and other developmental opportunities for South African arts and culture nationally and globally through mutually beneficial partnerships, thereby ensuring the sustainability of the sector".

Additionally, the proposed facility ties into the DAC's aim to "Develop and monitor the implementation of policy, legislation and strategic direction for the identification, conservation and promotion of cultural heritage" - as The Imagination Station highlights the importance of creativity in the increasingly materialistic South African society. The Imagination Station thus offers a public facility as an empowering information resource - as with the DAC's mission to "Guide, sustain and develop the archival, heraldic and information resources of the nation to empower citizens through full and open access to these resources."

In line with The Imagination Station offerings, the DAC lists a selection of its major services as:

1. Supporting informal arts education and training;
2. Supporting development and access to the arts;
3. Supporting excellence and sustainability in the arts;
4. Encouraging co-operation and networks within the diverse heritage of South Africa;
5. Developing and investing in cultural industries in partnership with the private sector.

Aptly stated, the DAC proclaims that "Investing in Culture Programme promotes job creation, skills development and economic empowerment". It has a special link to cultural initiatives for the Youth in Arts and School Projects; which is accommodated by The Imagination Station targeting adolescent learners."

## 2.2 Funding Partner



### FNB Joburg Art Fair



Figure 20: FNB's logo; involvement & sponsorship of Art; Inner City National Head Office

### First National Bank [FNB]

The Imagination Station's design, construction and maintenance costs will be privately sponsored by First National Bank [FNB] as part of its corporate social responsibility contribution.

FNB demonstrates continued steadfast relations in sponsoring cultural events, as with the Johannesburg Art Fair. Additionally, it holds a vested interest in the Johannesburg Inner City, as its National Head Office occupies the precinct directly East of the proposed Newtown site. Having direct, pedestrian access to such a facility would, additionally, add value to FNB's workings. Staff could utilise the facility to improve their corporate decision making and operation processes, in line with IBM's corporate creativity study [2010:(online)].

Exceeding such factors, it would be beneficial for FNB's corporate image and marketing to be affiliated with such a dynamic and much needed public facility situated in the 'heart of Africa'.

## 2.3 Management Partner

### BUSINESS AND ARTS SOUTH AFRICA

From seed, to strength, to sustainability.

#### Mission

To ensure the relevance and sustainability of the arts in South Africa by providing expertise in developing partnerships between business and the arts.

#### Our roots

Business and the South Africa (BASA) is a non-profit company whose primary aim is to promote mutually beneficial and sustainable business-arts partnerships that will benefit society as a whole.

#### BASA in the 21st Century

Historically, funding for the arts from the private sector has come from charitable bodies that provide patronage support. But over time the focus has shifted to the corporate sector. BASA is a not-for-profit company that aims to ensure the sustainability of the arts in South Africa by providing expertise in developing partnerships between business and the arts.

#### Our core business

BASA's core business is to provide mutual, beneficial, sustainable and sustainable business-arts partnerships that will, over the long term, benefit the broader community.

Figure 19: BASA's logo; mission; involvement in Art

### Business Arts South Africa [BASA]

The non-profit organisation, Business Arts South Africa [BASA] will run The Imagination Station. Such administration is in line with BASA's mission statement of ensuring "the relevance and sustainability of the arts in South Africa by providing expertise in developing partnerships between business and the arts" [BASA, 2012:(online)]. BASA will co-ordinate the Centre Facilitators.

### Facilitators

Facilitators provide external input into the programmatic workings of the Centre by offering workshops and courses. Such facilitators will come from a range of backgrounds: from the Media Sector comprised of Filmmakers, Journalists, Writers and Sound Artists; to Creative and Functional Thinkers such as Industrial Designers, Architects, Graphic Designers and Photographers. Such input will add another dimension to the curatorial aspects of the facility through providing another layer in ensuring the Centre's programmatic offerings remain fresh and relevant to the times.



Adolescents: Senior School Learners



Adolescents: Tertiary Learners



Young Adults



The General Public

Modes of arrival/departure:

From such a vast user group, the different forms of arrival/departure vary from walking; school/tertiary/public bus; Gautrain; taxis; or private motor vehicles [discouraged]. The architectural design accommodates all modes.

Figure 21: Figure 19: Programmatic Target User Group [Author, 2012]

## 2.4 User

---

### Introduction

The Imagination Station users encompass current precinct users and creative artistic groups; as well as drawing in new users from the greater Johannesburg and Gauteng context. Its design aims to engage users moving through the site, as well as enticing individuals into its programmatic workings through offering social facilities such as cafes, external seating and spaces to loiter. The design therefore aims to create a welcoming community atmosphere - as re-iterated by Alexander *et al's Pattern Number 101* (1977:494).

### Target User Groups

The Imagination Station's Target User Groups can be quantified into:

1. Adolescents [13 to 19 year olds: Secondary and Tertiary Learners];
2. Young Adults [20 to 40 year olds];
3. The remaining General Public

### Adolescents | Learners

Adolescents can be brought to The Imagination Station by their schools, with prearranged facilitation preferred. Individuals and smaller groups can also utilise the facility outside formal school hours.

Many of the current precinct user learners come from underprivileged backgrounds. The Imagination Station is invaluable in improving such circumstances: as underprivileged learners are able to think of ways to progress towards improving their circumstances through imagination and a creative outlook.

As Lewis Hyde [2007:251-2] states: "The greatest art offers us images by which to imagine our lives. And once the imagination has been awakened, it is procreative: through it we can give more than we were given, say more than we had to say...In this way the imagination creates the future. The poet 'places himself where the future becomes present.'"

### Young Adults

Young adults are seen to constitute a pioneering, entrepreneurial generation. Such users might utilise the facility to expand their ideas for running their own creative businesses; or simply as a form of recreation. Alternatively, the social community aspect of the Centre might appeal to them - in terms of the infectious creative energy of the genius loci; or discussions with like-minded individuals.

### General Public

The General Public will predominantly utilise the Centre over weekends. Families will enjoy the facilities together, while the elderly can feel societally included in the general buzz of the facility. While it is something to fill their otherwise monotonous days, pensioners are able to impart their knowledge and experiences onto younger users - as forwarded by Christopher Alexander *et al* [1977:421] in a holistic means to teaching children - while simultaneously being inspired by the youth's



---

vigour. As reiterated by du Preez [2012:(interview)], “it takes a village to raise a child.”

## Diversity Cross-pollination

Cultural diversity of users, as encouraged by Alexander et al (1977:50), is also promoted to create an enriching environment and aptly reflect the diversity of Newtown’s user groups.

The facilitated mix of users, in terms of age, background, socio-economic standing and race, bring crucial cross-pollination of diversity into play. Such co-creation is fundamental to expanding new paradigms and creative works [du Preez, 2012:(interview)]. South African society is seen to be too compartmentalised - to its detriment, such that The Imagination Station aims to utilise user diversity to strengthen its social outputs.

## 2.5 Architectural Intentions

---

### TO DESIGN A PLACE...

#### WHICH

- satisfies its programmatic needs
- inspires creativity; the cross-pollination of ideas; and spaces of debate and furthering of ideas

#### WHERE

- its users can articulate the creative identity of the self, the collective and the area

#### TO

- forge, foster and articulate the importance of creativity in Twenty-First century society

#### AND

- excites the user as per the creative nature of the stipulated programme and facilitating spaces
- facilitates a creative community
  - in terms of both the immediate community and wider users
- aids the promotion of community congregation
- adds value to the Newtown urban context and user’s existence

## THE RELEVANCE OF ARCHITECTURE TO CREATIVITY

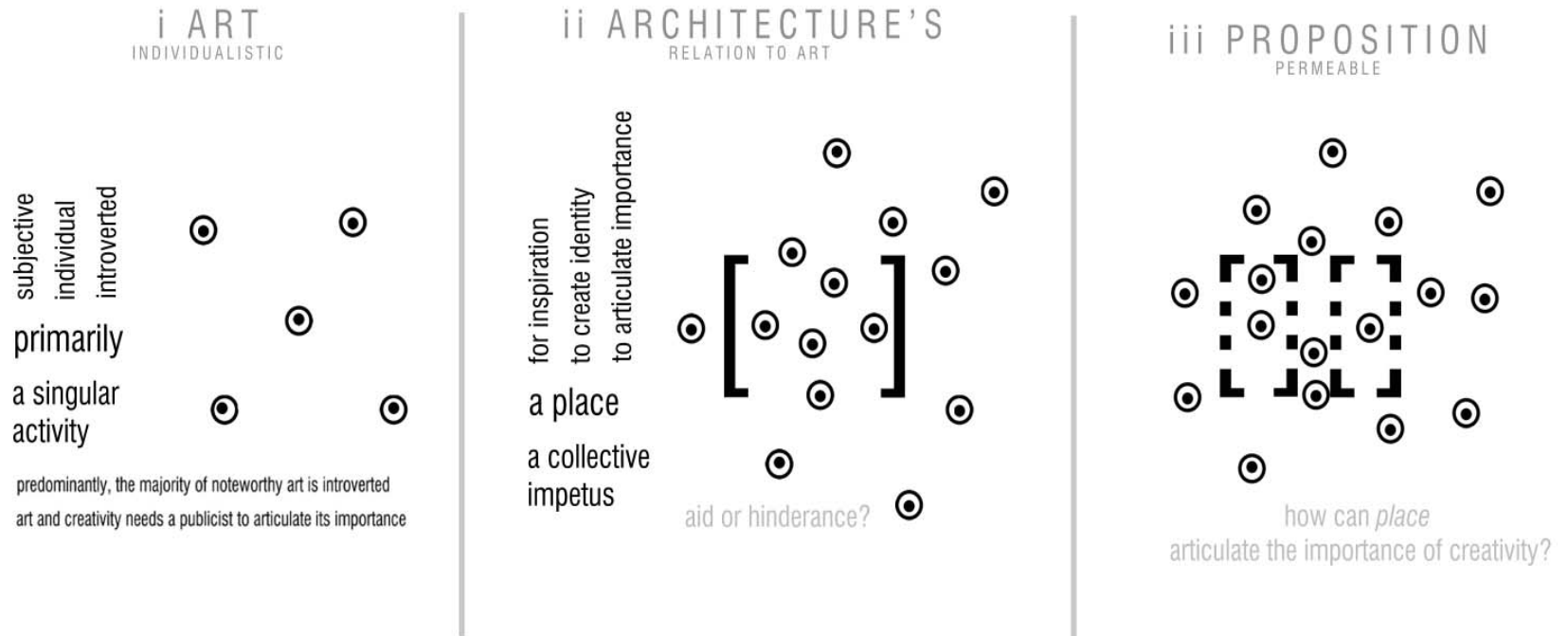

Figure 22: The relevance of architecture to the imagining and creative idea realisation [Author, 2012]

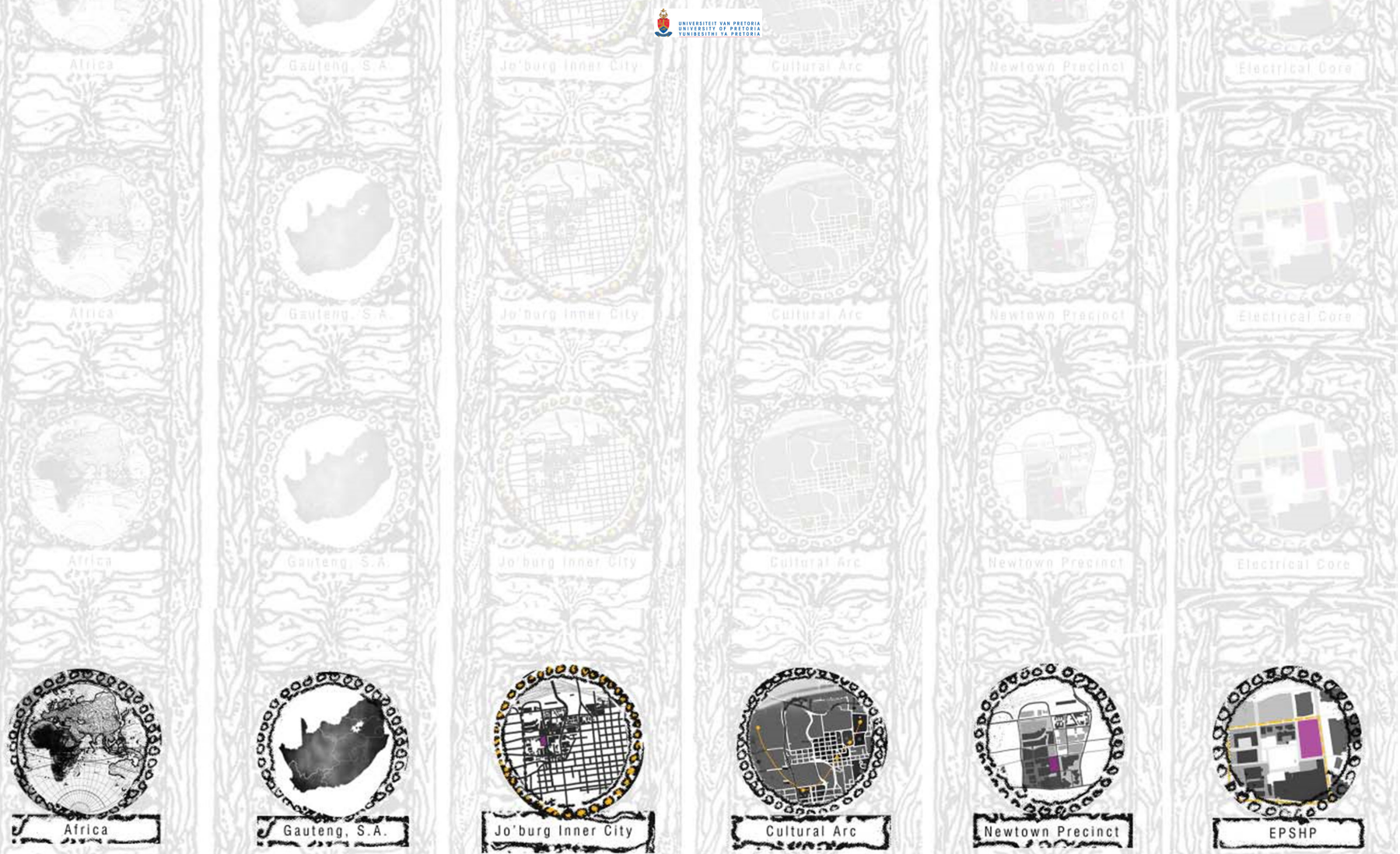

Figure 23: The site of the proposed project is located in Africa: South Africa: Gauteng Province: Johannesburg Inner City: The Cultural Arc: Newtown Precinct: North East Corner of the EPSHP [Author, 2012]

3.1 Introduction 3.2 Johannesburg Inner City Urban Context 3.3 Cultural Arc  
3.4 Greater Newtown Urban Context 3.5 Newtown Precinct  
3.6 Newtown Electric Power Station Heritage Precinct 3.7 Selected Site  
3.8 Mapping 3.9 Urban Response 3.10 Proposed Framework 3.11 Architectural Response

## 03 cultural landscape

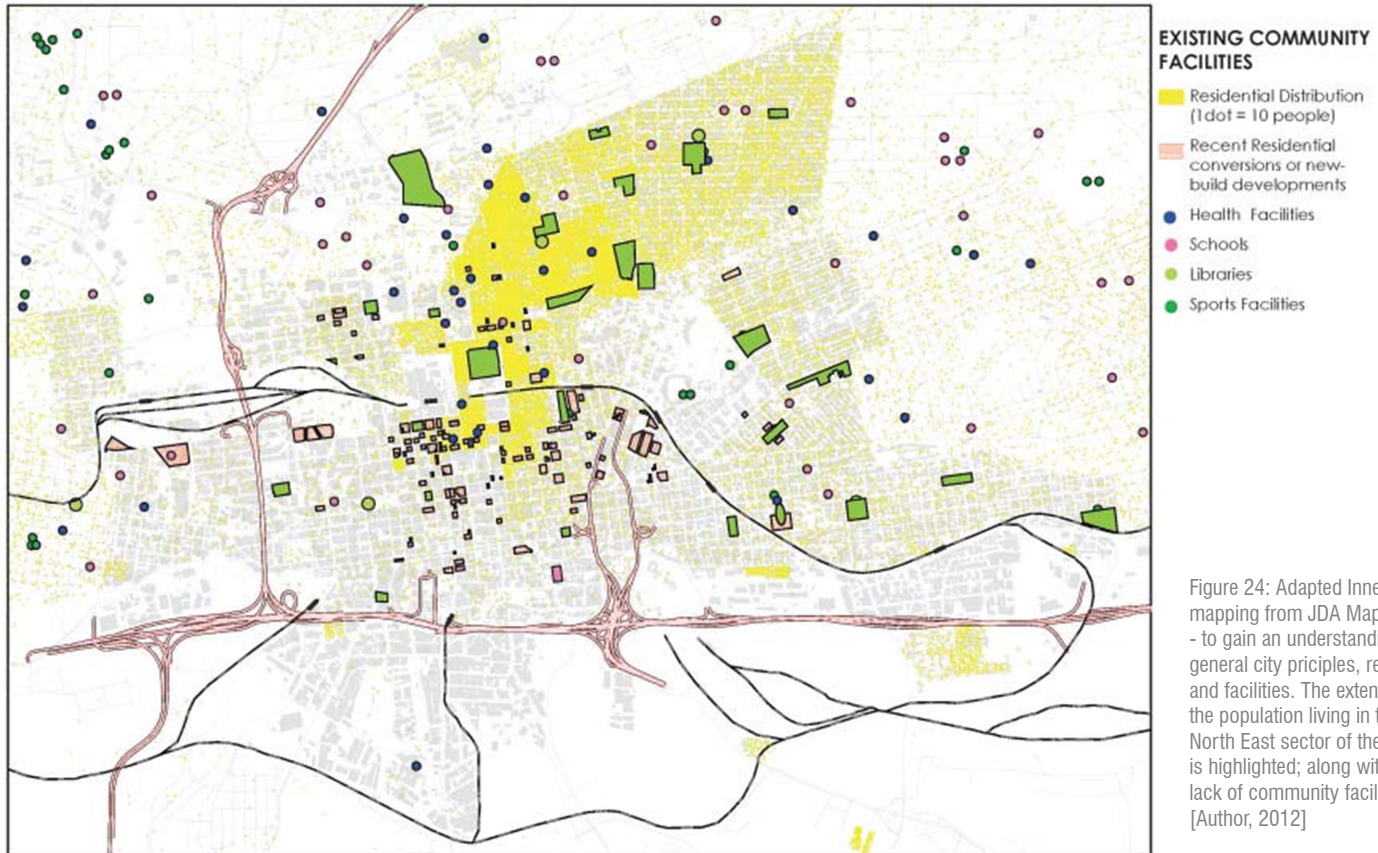

Figure 24: Adapted Inner City mapping from JDA Maps 2009 - to gain an understanding of general city principles, regions and facilities. The extent of the population living in the North East sector of the city is highlighted; along with the lack of community facilities [Author, 2012]

## 3.1 Introduction

### Urban Context

The Imagination Station occupies Erf 3 of Lot 599 in Johannesburg's former electricity generating powerhouse in the Newtown Precinct. The precinct played an integral role in the expansion of Johannesburg as a globally relevant city through its provision of power to the developing city.

## 3.2 Johannesburg Inner City

### Historical Time Frames

#### Founding

Johannesburg was rapidly founded as a 'boom town' typology upon the discovery of its gold reef; with the resulting gold rush of 1886 drawing mining immigrants from around the world [Chipkin, 1993:5]. The initial haphazard, prefabricated corrugated-iron-timber-framed shanty-town, developed to follow international architectural styles and technological advancements through its history [Chipkin, 1993:146]. With its wealth developed from mining, Johannesburg soon took the lead in functioning as South Africa's financial power house, with Ann Bernstein [2002:9] stating: "When Johannesburg sneezes, South Africa catches a cold."

#### Contemporary Times

While Johannesburg's Inner City acted as the vibrant core of the City from its founding, the Inner City experienced decline in its latter

years and the Central Business District [CBD] relocation to a new CBD further North in the late Twentieth century. The Inner City is still characterised by much blight and under-privileged residential living conditions, while expansive parts of it are being redeveloped and gentrified - such as Braamfontein and the Maboneng Precincts.

While the Sandton CBD houses the Investment Banks, the Inner City is seen to house four major multi-national private bank's Head Offices, being: First National Bank, ABSA Bank, Standard Bank and Liberty Life. Many more corporations are re-analysing the revived potential of the Inner City due to the promotion of investment taxbacks and implemented managerial districts.

## 3.3 Cultural Arc

---

### Introduction

Such Inner City revitalisation is seen to combine to form the outline of an 'arc' along the Inner City's Northern border in an East-West direction. The 'Cultural Arc' has officially been strategised to spur creative development in the city. The key nodes commence with Constitution Hill; the Civic Centre; Braamfontein; Newtown; and end at the University of the Witwatersrand.

The cultural arc has come to embody a dynamic region of nodes with much adaptive re-use, alterations and/or newly constructed buildings. Rebates spur such development, as well as the appeal of the richness of the historical memory of the region being adapted for contemporary lifestyle needs. The region's potential also lies in the area being bordered by high densities of low socio-economic residents in desperate need of public facilities and employment.

### Cultural Arc Precinct Nodes

Constitutional Hill encompasses the recently redesigned Constitutional Court building and precinct; with its light beacons articulating the Braamfontein Ridge.

Johannesburg Civic Centre encompasses The Johannesburg Theatre.

Park Station Precinct offers the inter-transportation node of Park Station.

Braamfontein has recently gained a 'slick designer', gentrified identity appealing to wealthy young professionals. Braamfontein's development has been spurred by 'Play Braamfontein' - directed by Adam Levy. Such energy can be extended down to the south of the inner city, albeit in a different manner.

Newtown encompasses the feeling of a museum precinct with its historical industrial structures and lower density away from the bustle of the inner city.

The University of the Witwatersrand forms a solid core of learning, where new paradigms are encouraged in its academic quest.

### Potential of the Area

The Cultural Arc has good potential for use by mixed socioeconomic groups through its range of transportation means - including the BRT Bus system and Gautrain stop at Park Station. The Cultural Arc nodes offer mixed use facility prospects, combined with a historical sense of place forming their common backbone.

Figure 25: Cultural Arc Nodes:  
Energy and Investment [Author, 2012]

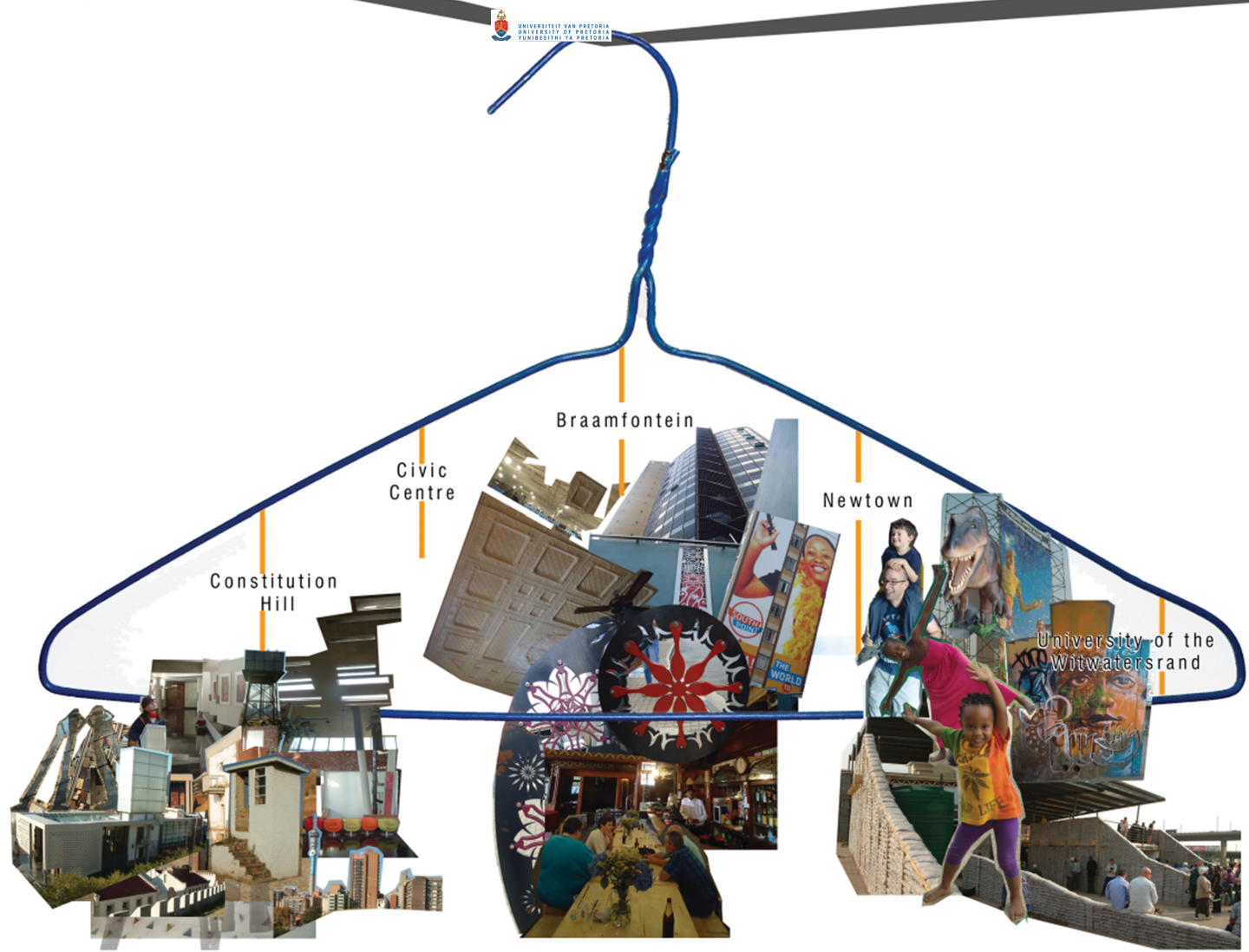

students | city's critical mass | gentrification | disadvantaged inhabitant nearby | corporation | developers | entertainment + arts hub



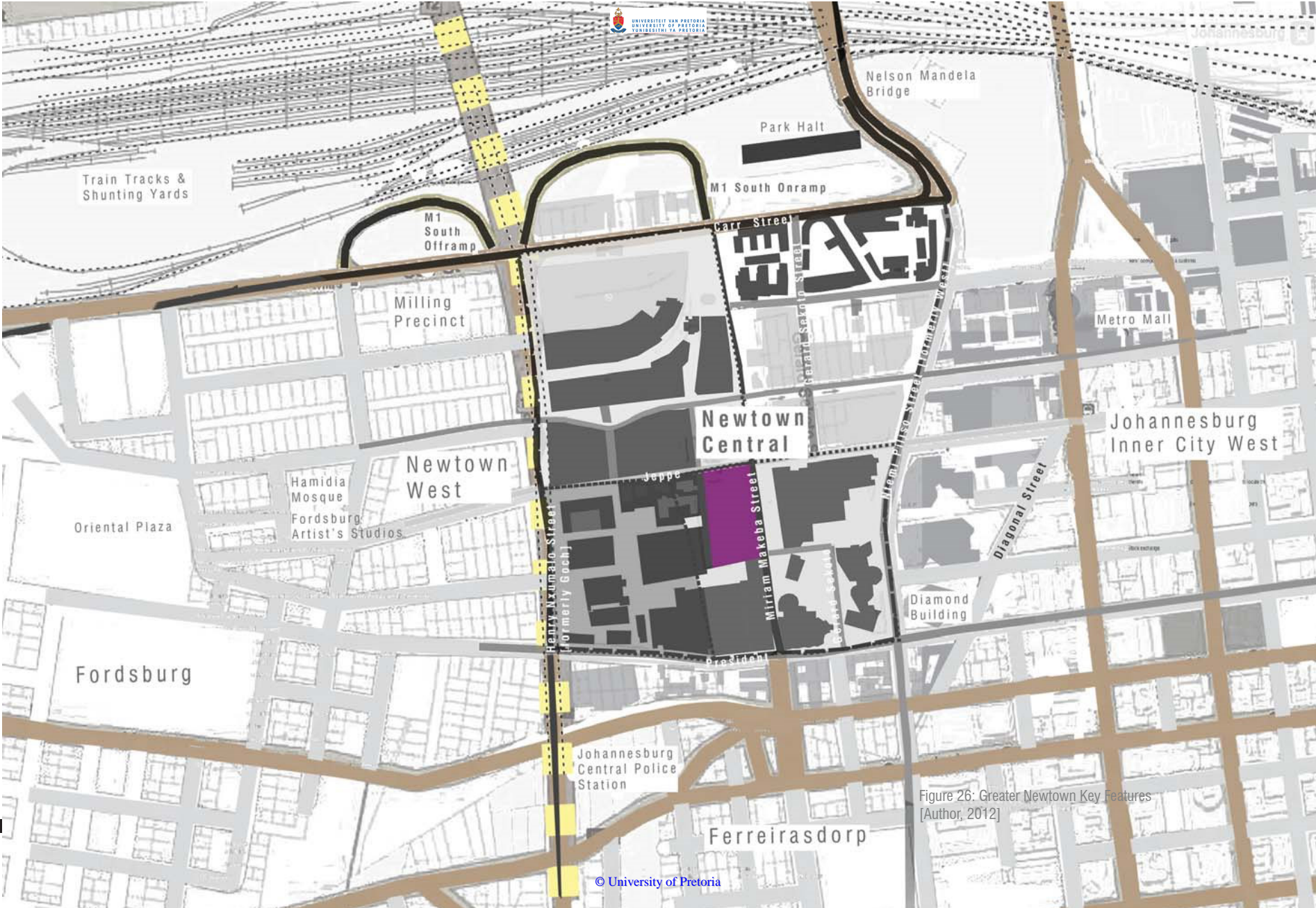

Figure 26: Greater Newtown Key Features  
[Author, 2012]

## 3.4 Greater Newtown Urban Context

---

### Newtown in relation to Johannesburg Inner City

#### Newtown Historically

The area currently called 'Newtown' was on the western edge of Johannesburg's early twentieth century vibrant cosmopolitan Inner City hub of retail, office and entertainment venues. Newtown was seen as outside the town boundaries, such that low socioeconomic mixed races lived there, with many making bricks along the bordering Braamfontein Spruit. South Africa's first forced removals cleared the area for the electricity power station and transportation centre after the Anglo Boer War of 1899 - 1902. Johannesburg's main goods and passenger station was located along Newtown's northern boundary in the 1890s [Newtown Heritage Trail (NHT), 2010:(online)].

### Inner City Intermediate Period Influence

The change in status of Johannesburg's Inner City residents in the 1970s to 1980s, resulted in urban blight. In response, the majority of Inner City businesses chose to relocate to the new Sandton Central Business District in the 1990s [Chipkin, 1993:318].

### Recent Decades

There have been numerous proposed urban design frameworks commissioned by Development Agencies and undertaken by GAPP Architects and Urban Designers in recent decades; although few have been completely implemented. Newtown's contemporary cultural richness can be seen to come from the historical structures that directly speak of Johannesburg's history and development, while being incrementally adapted to Twenty-First Century lifestyle requirements.

### Newtown's Key Features

The original 1895 Park Halt Station Structure reminds precinct users of Johannesburg's history and international architectural relations; while the adjacent Nelson Mandela Bridge conceptually speaks of endeavouring to overcome the divides in the South African nation.

Other relevant contemporary features in the greater Newtown area include the Metro Mall taxi rank and shopping complex. Metro Mall has a holding facility for 1750 taxis; 500 traders and additional formal retailers, with approximately 150 000 commuters utilising the transport facility [Deckler et al, 2006:69].

Diagonal Street acts as a historical marker for the Western edge of the Johannesburg Inner City, constituting the original *Randjieslaagte* farm and gold mining triangle of 1886. Traditional 'muti' shops in single and double-storey Victorian and Edwardian buildings are interspersed with concrete and glass skyscrapers. Diagonal Street also housed the

---

Johannesburg Stock Exchange from 1978 until 2000 [NHT, 2010:(online)].

The Diamond Building at 11 Diagonal Street is viewed as one of Johannesburg's major landmarks [NHT, 2010:(online)].

The Johannesburg Central Police Station, known as John Vorster Square until 1997, was regarded as "Johannesburg's most sinister site" [NHT, 2010:(online)] in the Apartheid era due to its Apartheid detentions, tortures and police brutality.

The Police Station visually forms the southern boundary between Newtown and Ferreirasdorp. Ferreirasdorp lies to the South of Newtown, having been named after the 1880 mining camp of Colonial Ferreira. The area's mini-Chinatown, which developed at the beginning of the twentieth century, has largely dispersed to other parts of Johannesburg [NHT, 2010:(online)].

Newtown West is defined through its dense building fabric and differing land-use activities in comparison to Central Newtown. Industrial

and small scale manufacturing occurs on the ground floors of the Victorian, Edwardian, Post-Edwardian and Art Deco warehouses; interspersed with night-time venues and adaptive re-use loft apartments [NHT, 2010:(online)].

The Milling Precinct is located in Newtown West. Premier Milling Company has a deep-rooted history in Newtown; running concurrently since 1903 with the founding of Johannesburg. Three years after its founding, the maize mill started to rise to prominence as the city's main milling compound, until its eventual decline and closure in 1994 [NHT, 2010:(online)].

Another successful business in Newtown West is Price's Candles, which was the first international branch of the British Edwards Price and Co. candle manufacturers of 1830 [NHT, 2010:(online)].

The Hamidia Mosque of 1906 is culturally significant due to Ghandi and Muslim leaders burning more than 1200 registration certificates in front of the mosque in 1908 -

as South Africa's first public Pass burnings [NHT, 2010:(online)].

The Oriental Plaza, in neighbouring Fordsburg provides a taste of Indian culture. Traders have occupied the shopping complex since 1975 when they were forcibly removed from Pageview [NHT, 2010:(online)].

The area is interspersed with artistic communities, as seen with The Fordsburg Artist's Studios - a non-profit organisation promoting visual arts [NHT, 2010:(online)].



### 3.5 Newtown Precinct

#### Mapping Newtown's Buildings Contemporary Newtown

##### General

Since 1990, Newtown has been promoted as a cultural precinct to revitalise the declining Inner City and Precinct itself [NHT, 2010:(on-line)]. Newtown currently houses:

- The City of Johannesburg's Department of Arts, Culture and Heritage
- The Market Photo Workshop and The Artist Proof Studio
- Moving into Dance and The Dance Factory
- Bassline Jazz Centre
- The Johannesburg Development Agency
- The South African Reserve Bank

Figure 27: Newtown Precinct - Map of Key Features [Author, 2012]  
Figure 28: Historic Newtown Photographs [NHT, 2010]

---

## Specific Key Features

[Letters] correspond to letters on accompanying map - *Figure 27 on page 55.*

### [a] The Johannesburg Fresh Produce Market Building [1913]

The Johannesburg Fresh Produce Market was established at Market Square in 1893. It formed Johannesburg's epicenter, with retail, banks and businesses developing around it [NHT, 2010: (online)]. In 1913 the market relocated to Newtown for greater space. The new structure came from Britain and is "considered one of Johannesburg's finest examples of Edwardian industrial architecture" [NHT, 2010:(online)]. Bustle characterised the market - where meat, fish, fruit, vegetables, dairy produce and tobacco were auctioned with more than 8 000 visitors on Saturday mornings. There was also a nearby abattoir and tannery.

The market's turnover was R2.4-million in the 1970s, with two-thousand tons of fresh produce moving daily through the market.

Additional space was thus required. Africa's largest fresh produce market therefore relocated to the industrial area of City Deep [Business Day, 2009:2]

The market building has housed the Market Theatre and Museum Afrika since 1976 and 1994 respectively.

### [ai] Museum Afrika

Museum Afrika started as a private collection by Dr John Gubbins in 1915 with the aim of narrating South Africa's complete history through graphics, manuscripts, letters, coins, relics and medals. Museum Afrika was formally established in the Johannesburg Public Library in 1935. The collection of over 850 000 objects was re-evaluated to become the first to show black, as well as worker histories [NHT, 2010:(online)].

The building was also used for the Johannesburg Biennales: to create a dialogue between the national and global art worlds. The Museum houses one of South Africa's five camera obscuras [NHT, 2010:(online)].

### [aii] The Market Theatre

The Market Theatre was opened by anti-Apartheid actors Barney Simon & Mannie Manim who converted the old Indian Fruit Market's voluminous space into three theatres. It is significant as one of the first theatres operating in Apartheid to have mixed race casts and to depict controversial anti-Apartheid material. It is thus known as South Africa's Theatre of the Struggle, with Simon stating that theatre was used as a means for people to understand one another better [NHT, 2010:(online)].

### [b] Historic Buildings facing the Market Theatre

The programmes of the buildings facing the Market Theatre always related to the programme occupying the Market Building. Goldsmiths and trades occupied the premises in the Market days; while theatre schools, cultural pursuits and first floor offices have inhabited the buildings in the time of the Market Theatre. An informal pedestrian street market also developed in the late twentieth century [NHT, 2010: (online)].



[c] Mary Fitzgerald Square

Mary Fitzgerald Square was originally a wagon site known as Aaron's Ground, then Market Square before it was renamed in 1939 after Mary Fitzgerald, the first South African female trade unionist and political activist. Its cultural significance lies in it being the site for many political rallies, strikes and protests relating to political, electrical, mine, and/ or tram worker wage or race disputes [NHT, 2010: (online)].

[e] Railway Sidings & Potato Sheds

The informal railway siding sheds were formalised in 1911; with the railways serving the market. By the 1990s the sheds were largely disused. The sheds have since been dismantled for reconstruction on the site in the future 'Potato Sheds billion Rand develop

ment' shopping mall project [NHT, 2010: (online)]

[g] Kippies International Jazz Bar

The building was constructed in the 1980s as a replica of the 1913 Edwardian toilet block two-hundred metres North of the site. Its cultural significance lies in its international jazz venue recognition: being named after renowned saxophonist Kippie Moeketsi.

[h] Newtown Jazz Walk of Fame

The walk honours the contribution of key jazz musicians, such as Miriam Makeba and Ntengi Piliso, to South Africa's jazz tradition with brass plaques laid into the floor finish.

[f] Brickfields Housing Development

Brickfields is the largest public-private housing partnership pilot project in South Africa, with an approximate budget of R100-million, being completed in 2004. The development consists of 650 one-to-three bedroom flats catering to a range of income groups, with self-run Ground Floor retail spaces. The design integrates semi-private courtyard environments [Deckler et al, 2006:65].

### Transport Precinct

The first half of the twentieth century witnessed rapid growth of Johannesburg's transport sectors. The Transport Precinct developed in 1906 with sheds for the parking, administration and maintenance of the first electric trams. Power stations consequently developed to supply electricity for the



Figure 29: First & second left: Historic Newtown photographs [NHT, 2010]  
 Figure 30: Below opposite: 2001 Bus Factory Renewal [Author, 2012]  
 Figure 31: Right & left: Contemporary Newtown [Author, 2012]  
 Figure 32: Below middle - left: Brickfields [Deckler *et al*, 2006; Author 2012]



transport system and city needs [NHT, 2010: (online)].

[j] South African Reserve Bank

Occupies the original 1906 Tram Shed site [NHT, 2010: (online)].

[d] The Bus Factory

The Bus Factory was built to house trams for repair. The notion of ‘transportation’ has deeper levels of significance than merely a form of accessibility and means of motion: as with the Apartheid Government’s Separate Amenities Act of 1953, transport became racially segregated. Buses for black people did not stop in the inner city as the Government desired a solely white city. Newtown’s relevance lies in it housing terminal points for black people as Newtown occupied the edge of the city boundary [NHT, 2010: (online)].

The 1970s saw the trams being replaced by double decker buses; with the entire Bus Factory eventually being renovated in 2001 to offer creative business spaces. The Bus Factory now contains the offices of the Johannesburg Development Agency [JDA], which manages inner city development and urban regeneration. Space is also rented by The Artist’s Proof Studio, which has taught printmaking and economic independency since 1991 to disadvantaged learners.

Lael Bethlehem, CEO of the Johannesburg Development Agency, aptly states [NHT, 2010: (online)]: “The Bus Factory is a perfect setting for our work. Urban regeneration is ultimately about creativity and this is a creative space. We can feel the history of Newtown all around us and we use this as an inspiration.

We are also committed to creating space for artists and cultural workers. The revitalisation of the inner city cannot take place without a vibrant contemporary culture.”

[i] Market Photo Workshop

Formerly Johannesburg City’s Transport Department building in 1934, The Market Photo Workshop was founded by David Goldblatt in 1989 to provide training to underprivileged South African photographers. It has produced many globally-renowned photo-journalists, such as Zanele Muholi, Jodi Bieber and Nontsikelelo Veleko [NHT, 2010: (online)].



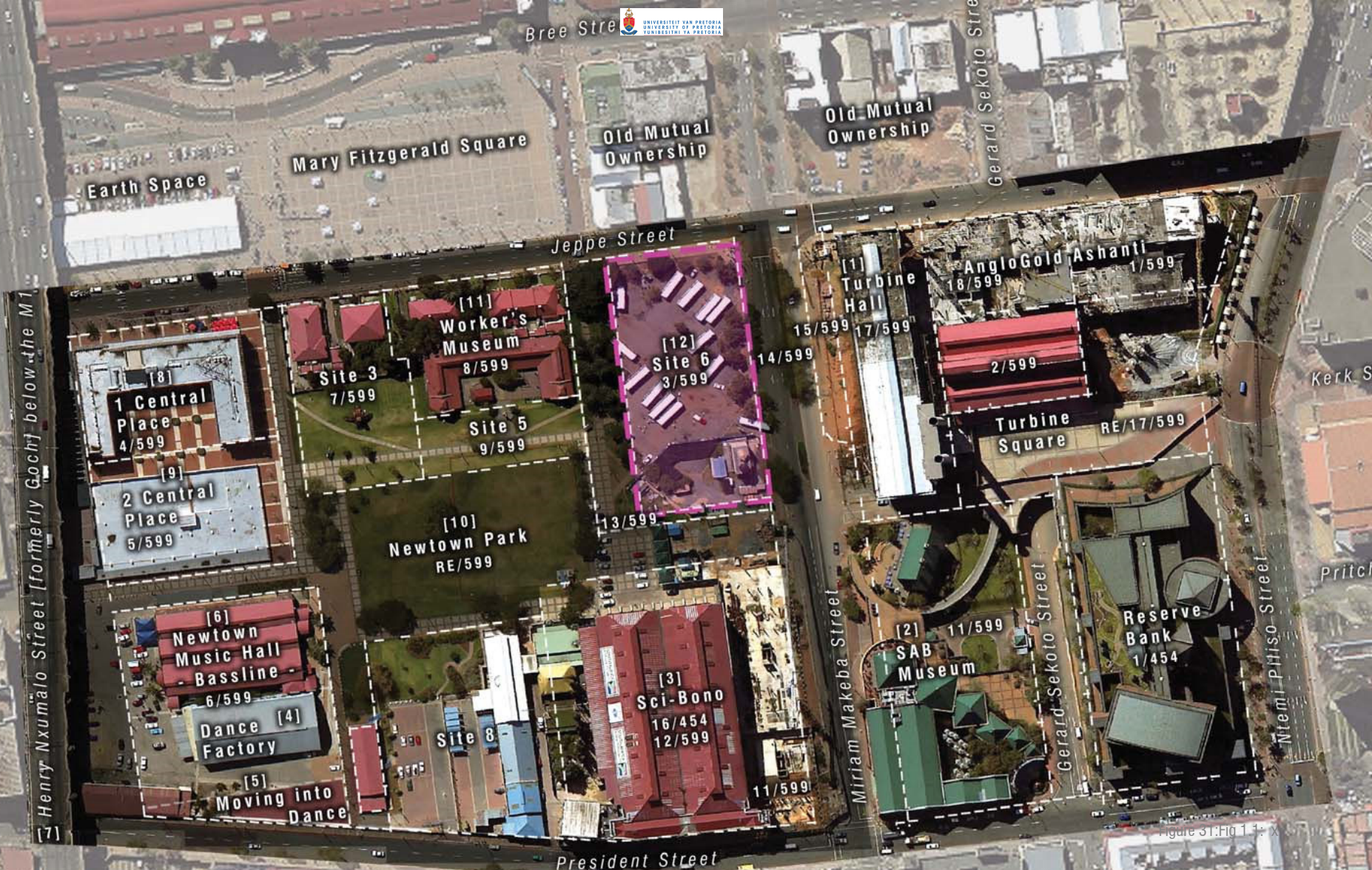

Figure 31: HQ 13: X

Figure 39: The Newtown Electric Power Station Heritage Precinct [Author, 2012]



## 3.6 Newtown Electric Power Station Heritage Precinct

[All Figures by Author, 2012]

### Introduction

The Newtown Electric Power Station Heritage Precinct is comprised from an assortment of buildings referencing different eras and preoccupations governing Johannesburg in each era.

### Existing Key Buildings



[1] Turbine Hall | 1927 | -  
Neighbour to Site

The Turbine Hall was a component of the 1927 Jeppe Power Station, which was the largest of Johannesburg's steam driven power stations until superseded in 1942 by Orlando Power Station. The other station components included the North and South Boiler Houses and three concrete cooling towers. The power station consumed a train load of coal per day. It had a turbulent history since closure in 1961; until it was adaptively reused as Anglo-Gold Ashanti's Headquarters in 2009 [NHT, 2010:(online)].



[2] South African Breweries Museum  
[SAB World of Beer] | 1994 |

The Breweries Museum occupies the original site of the Second President Street Power Station, which was demolished in 1994 for the Centenary Building [NHT, 2010:(online)].



[3] Sci-Bono Discovery Centre in The Electric Workshop [First President Street Power Station] | 1906 | - Distant Neighbour to Site

The First President Street Power Station was constructed in 1906 to power the new electric tram system. It was closed in 1907 due to a boiler house explosion. The Second President Street Power Station was thus constructed. The First Power Station was used to repair machinery and became known as The Electric Workshop.

In 2004, the building was adaptively reused for Sci-Bono. It is the biggest interactive science

centre in Southern Africa, funded by The Gauteng Department of Education and the private sector. In 2009, a new Eastern section was added in order to offer conference and education facilities [NHT, 2010:(online)].

Sci-Bono aims “to improve public engagement with science and technology and build South Africa’s science, engineering and technology capacity. The Centre trains teachers; provides career information to learners; supports mathematics, science, technology and information and computer technology classes” [Sci-Bono, 2012:(online)].



[4] The Dance Factory | 1963 |

The Dance Workshop hosts classes, workshops, performances and annual festivals like the Joburg Arts Alive International Festival. Its significance lies in it being the only dedicated dance theatre in South Africa upon founding in 1994 ” [NHT, 2010:(online)].



[5] Moving into Dance | 2009 |

Moving into Dance was established in Sylvia 'Magogo' Glasser's Northern suburb garage as a means of cultural resistance to Apartheid in 1978. The Newtown studio has become the country's "foremost professional dance and training institution" [NHT, 2010:(online)]. A new state of the art facility was commissioned by the JDA and designed by Phil Mashabane in 2009 [NHT, 2010:(online)].



[6] Baseline | 1963 |

Baseline opened in the old Newtown music hall in 2004 with a 1000-capacity concert venue and rehearsal facilities. From 1995 to 2010 it has hosted over 3000 concerts. A statue of singing legend Brenda Fassie sits outside Newtown with a microphone [NHT, 2010:(online)].



[7] M1 Freeway [De Villiers Graaf]

The South and North-bound M1 through Newtown was one of the first components of the freeway to be constructed in the 1980s. MuseuM Africa's western facade had to be demolished to provide for it. The freeway section above Newtown is the busiest in the Southern Hemisphere with over 300 000 commuters using the portion every weekday [NHT, 2010:(online)]. This is due to it being the major link between the Central Business District in the South and the Sandton Central Business District to the North [NHT, 2010:(online)]. As such, it offers the opportunity for large scale installations on Mary Fitzgerald Square and Newtown Park to be seen from the highway and advertise the precinct's programme.



[8] No. 1 Central Place | 2005 |

No. 1 Central Place was designed by GAPP Architects and Urban Designers to provide office facilities above basement parking for the paying public and office tenants.

[9] No 2. Central Place |incomplete|

No. 2 Central Place aims to complete the opposing 'U-shape' complementing No.1 Central Place to form an internalised semi-private courtyard. At present, the basement is built up to Ground Level with a vacant derbigum waterproofed deck .



[10] Newtown Park

The current Newtown Park was the centre of the industrialised Electric Power Station Precinct in 1937. Its four 120 metre tall concrete cooling towers were a major landmark on the Johannesburg skyline. The towers were imploded in 1985 due to fears of structural failure [NHT, 2010:(online)].

The park is used by vagrants, school children and commuters during the day as a social space for sleeping, eating and relaxation respectively. Muffled motor vehicle noises give an air of calm to the park, which is only interrupted by a flutter of pigeon wings or a soloist with a guitar.

The Proposed Framework sees the park's opportunity as a quality social space for the areas visitors and the future densified residential population.



[11] Worker's Museum & Library  
[1913] - Direct Neighbour to Site

The worker's compound was built by the Johannesburg City Council to house Sanitary Department migrant workers in 1913. It later housed the Power Station workers.

The museum now tells the story of thousands of black migrant workers being recruited throughout South Africa to work on the mines, in factories and cities. They were separated from their rural families; were forced to sleep side-by side on concrete dormitory bunks with no privacy; with complete control being enforced by the Compound Manager. The difference in living conditions between white and black workers was pronounced, with white workers occupying semi-detached dwellings to the West of the compound [NHT, 2010:(online)].



[12] Workers Museum & Library - Entrance Pavilion

Contemporary entry visitor pavilion constructed out of steel, facebrick and glass with hot-pink glazed tinted-application. Materials are seen to contrast to the feeling of the historical materials of the museum in order to differentiate the new addition. The colour of the glazing stands out across the barren park void and gives visitors a point of reference and memory.



[13] BHBillon Outreach Training Academy

Contemporary fair-faced concrete building with reflective window application. Does nothing to add to the presence of the collective identity of the Precinct. Does not induce viable spatial creation in its monolithic form. Reflective windows subjectively give off an alienesque presence seen to be looking over the park without allowing any interaction back in return.



[14] Sci-Bono Conference Centre

Contemporary fair-faced concrete and steel building used as an extension to Sci-Bono to provide meeting rooms, an auditorium and teaching rooms for their high-school science, mathematics and computer science teaching programmes.

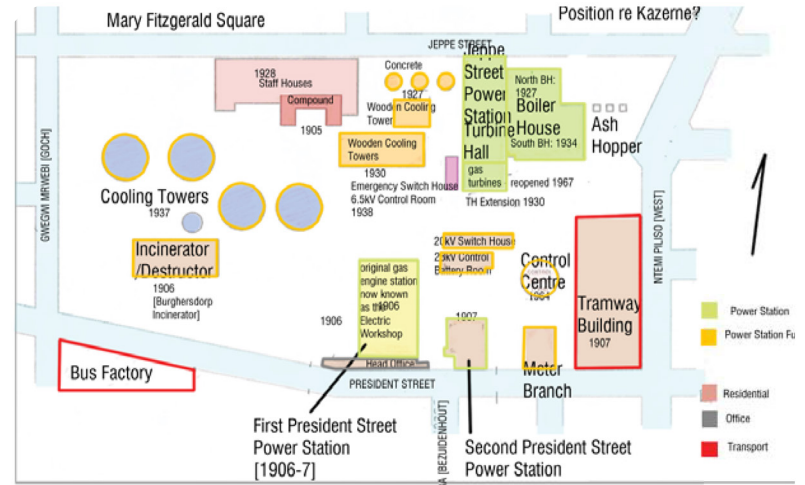

Figure 34: (far right) The historical nature of the Electrical Heritage Precinct: Photograph of The Electrical and Transportation Precinct showing the site's cooling towers in 1957 [Adjusted from Krige, 2005]

Figure 35: (top right) Plan of said photograph [Adjusted from Krige, 2005]

Figure 36: (bottom right) Site Plan from 1980 showing the historical structures [Adjusted from Krige, 2005]

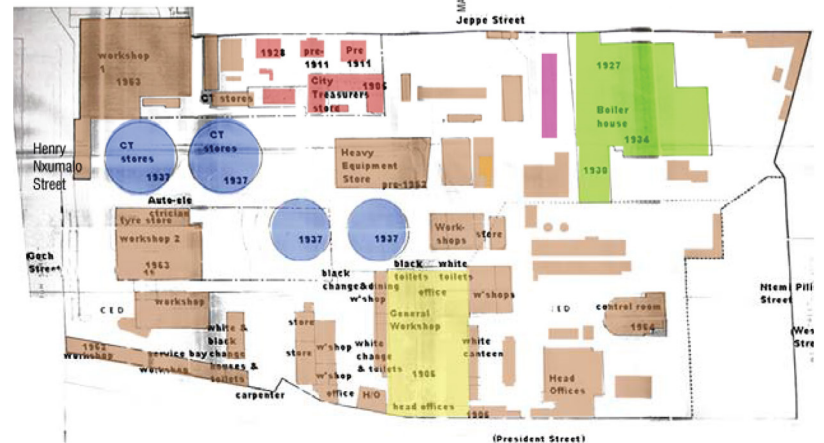





Figure 37: The site, looking North; showing the elevated base of the remaining lone concrete cooling tower [Author, 2012]



## 3.7 Selected Site

### Introduction

The selected site sits on the corner of Miriam Makeba and Jeppe Streets. Turbine Hall occupies the site to the East across Miriam Makeba street, with mature fever trees shading the avenue. The site to the North across Jeppe street is vacant; with spaces accommodating ground floor activities and upper floor living being schematically proposed via the framework.

### Current Site Elements & Use

The site is currently finished with gravel chips and a few inconsequential sapling trees. A remaining Electrical Precinct concrete cooling tower stands as a lone, alien-like object to the South; presently unused. It is aptly framed by sitting in a rectangular concrete basin edged by an upstand.

Sci-Bono currently uses the site as parking facilities. Even though past GAPP frameworks have made suggestions for buildings such as Media Centres to occupy the site, none have been developed.

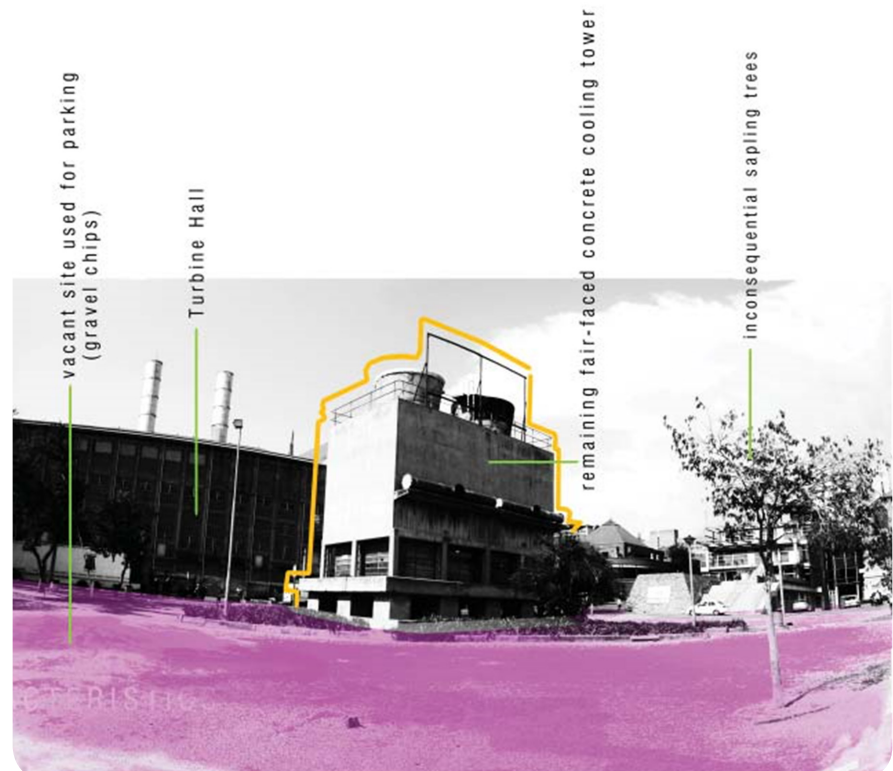

Figure 38: Looking East towards Turbine Hall  
[Author 2012]



### EXISTING SITE ELEMENTS

- 1 | Large exotic tree
- 2 | Boundary directs flow
- 3 | Young trees
- 4 | Loose gravel chip finish
- 5 | Existing Concrete Cooling Tower
- 6 | Palm Tree Walk
- 7 | Worker's Museum
- 8 | Miriam Makeba Street
- 9 | Jeppe Street

Figure 39: Plan and photographs of Existing Site Elements [Author 2013]

## Analysis of Immediate Neighbours



### The Worker's Compound

The building's significance lies in it being "one of the last surviving examples of municipal compounds for black male workers" [NHT, 2010:(online)]. It therefore reminds users of the migrant labour system, where approximately 70 governmental compounds and hostels operated in Gauteng [NHT, 2010:(online)].

The domestic single storey scale acts as an important neighbouring design informant. The proposed design must not overshadow

the historical relevance kept alive by the Worker's Compound building itself. In terms of materiality, the corrugated roof sheeting reflects Johannesburg's Victorian style upon boom town founding; while the worn red facebrick historically ties back to Brickfields [Newtown's current northern edge] as Johannesburg's original brickmaking location.



### Turbine Hall

The Turbine Hall's significance lies in its scale; considered proportions; detailing; and vast interior volume [Prins, 2006:12]. Its rhythm creates a key feature of the building, as well as the material palette of fair-faced concrete with facebrick infill.



### Sci-Bono

The key architectural features of Sci-Bono are its large scale, closed facade and massive interior volume. Its activities are extremely introverted with little programmatic articulation reflected through the building facade. The red-tone to the plasterwork adds another distinctive architectural feature to the material palette of the historic precinct.

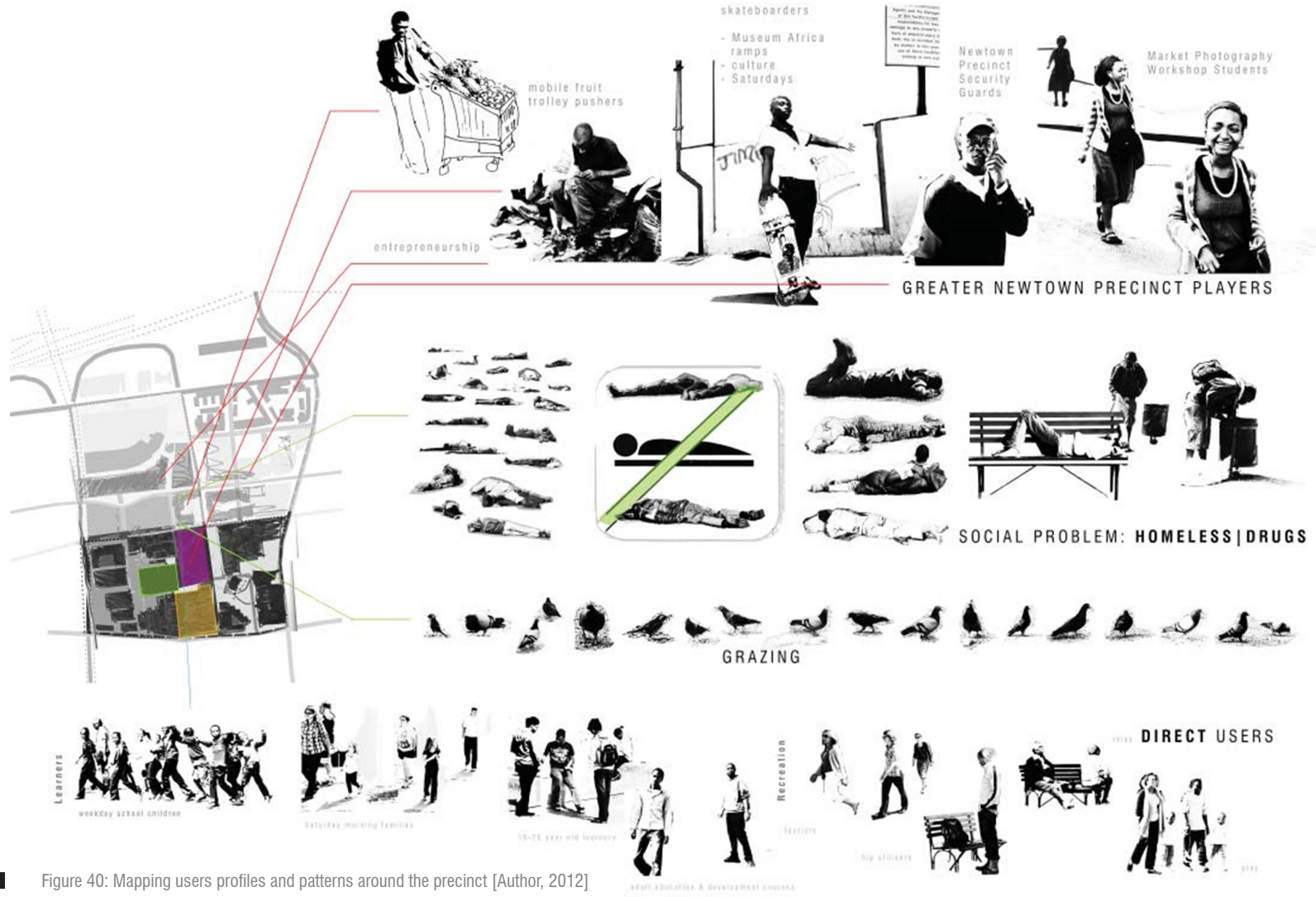

Figure 40: Mapping users profiles and patterns around the precinct [Author, 2012]

## 3.8 Mapping

---

### Introduction

Existing practices; movement routes; users and predominant activities were mapped in the Newtown Electric Power Station Heritage Precinct.

### Rhythms

The site experiences a rhythm in the school buses arriving in the morning; children assembling and being taken into Sci-Bono by guides. The children flood out of the Sci-Bono Electrical Workshop building at lunch time, to be greeted by entrepreneurial informal food sellers. The children sit in the park eating their lunch and are further pestered by informal goods sellers. The children leave in a flurry, after which the pigeons descend on the leftover crumbs. The Newtown Park becomes peaceful once again; with the lull of the M1 highway above creating a calming background muffle. The weekend has a similar calm atmosphere, with families visiting Sci-Bono and an informal Rastafarian market developing along the park edge.

### Movement Routes

Pedestrian movement is a great generator on the site; as Inner City pedestrian commuters constantly stream through the site in a North-Easterly to/from South-Westerly direction. This is due to their efforts to walk the shortest route on their way to and from work/ school/recreation.

Many commuters pause their travels to sit around the park edges in order to relax and observe the precinct activities, as illustrated by *Figure 41 on page 73*.

### Culture

The interest in art and craft is a defining factor of the Precinct users, as illustrated by *Figure 42 on page 74*.



Figure 41: Pedestrian movement routes proliferate through the precinct and map the rhythms of users [Author, 2012]

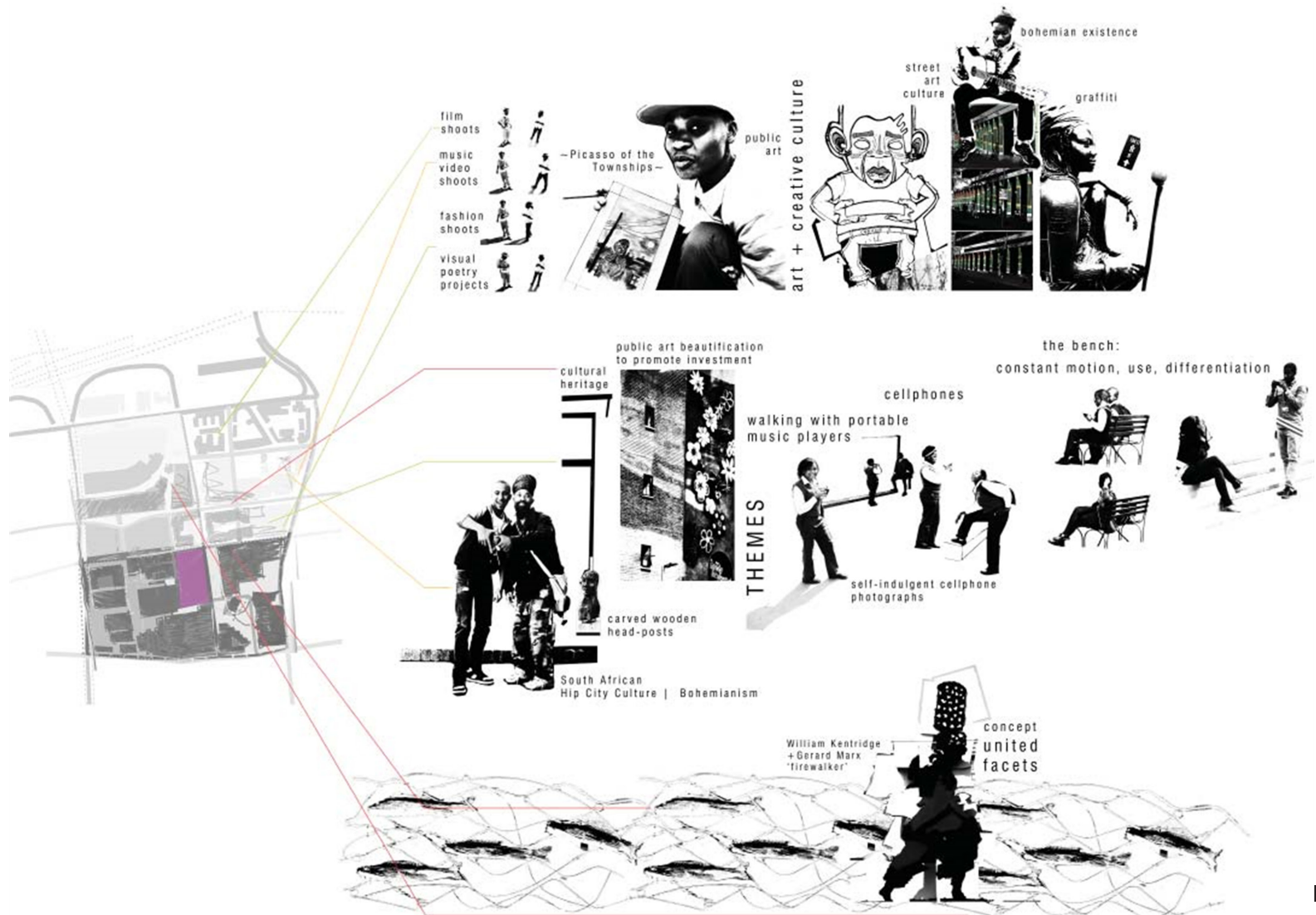

Figure 42: Newtown users show a profound interest in the arts and cultural pursuits [Author, 2012]

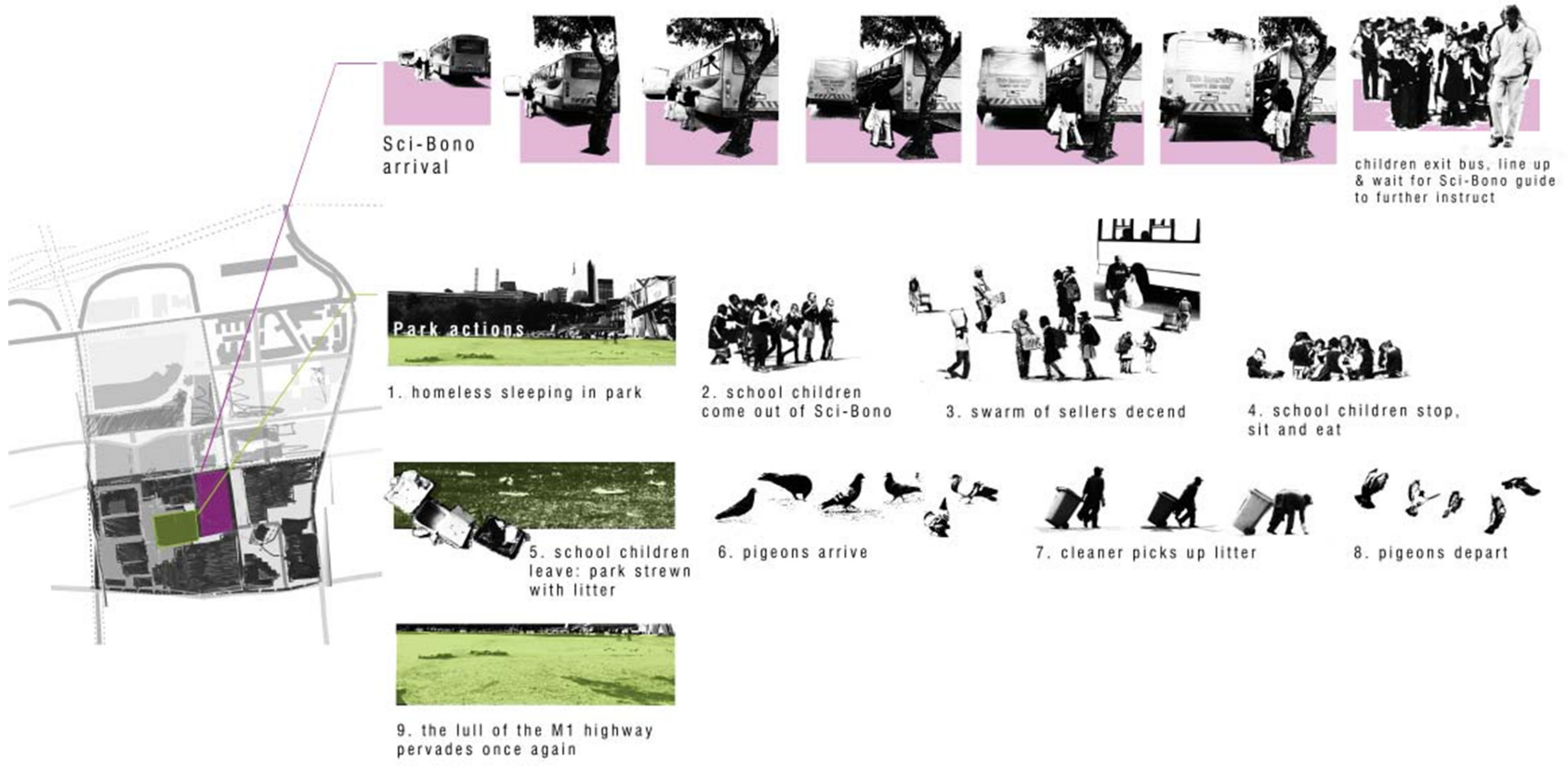

Figure 43: Daily processes in the Newtown Electric Power Station Heritage Precinct [Author, 2012]





## Land Ownership

The entire EPSHP - minus the land of the Reserve Bank and SAB World of Beer - is owned by the City Council [GAPP, 2001:9], as illustrated by *Figure 44 on page 76*.

The fact that the land is predominantly council owned, gives greater possibilities for precinct linkages and articulation. This fact also creates a strengthened spatial bond to the Newtown Precinct since precinct growth and building development/use can develop in line with area requirements as opposed to property developers ignoring the bigger picture when developing singularly owned sites.

Figure 44: Land Ownership [Author, 2012]

## 3.9 Theoretical Urban Response Cultural Precinct of Newtown, on the edge of Johannesburg's Inner City.

---

### Introduction

Theoretical guidelines from Christopher Alexander *et al's A Pattern Language* (1977) are used to underpin The Imagination Station's Urban Response. A large-scale view is taken before delving into the finer intricacies of the urban response.

### Precinct Character & Branding

In terms of Alexander *et al's* theories (1977), the Newtown Precinct needs to be branded as a particular region (1977:11 & 80). This has already been implemented to a certain degree by GAPP Architects & Urban Designers 2001 Framework, which branded Newtown as Johannesburg's Cultural Precinct. The industrial factory buildings have been adaptively re-used as dance halls, performance venues and museums, while being interspersed with cafes, offices and a more recent residential component which is seen to develop to a greater degree in the future. A similar language for outdoor furniture has been employed throughout the precinct in an attempt of unification. Users then feel that they belong to an identifiable neighbourhood (Alexander *et al*, 1977:87).

### Response to Current Movement Routes: Revived Site as the creation of an Activity Node

The site is located on a predominant intersection of pedestrian routes due to the long stretches of buildings to the East (Turbine Hall) and West (Workers Hostel & Housing) being impenetrable such that the amount of pedestrian passage has built up by the time The Imagination Station corner site is reached.

The site therefore easily develops into an *Activity Node* (Alexander *et al*, 1977:164) due to the number of 'community crossroads' that converge at its corners. This provides the Centre with good foot traffic from its inception, which will in turn help draw further activity to the site since "people seek out concentrations of other people" (Alexander *et al*, 1977:164).

Alexander *et al* continues by stating that the major pedestrian paths should converge in a public square. The design responds in keeping the internal square no more than 21m wide according to Alexander *et al's* advice (1977:165). The family of buildings around the square are also seen to work symbiotically together to

intensify their appeal to the target audience as stipulated by Alexander *et al* (1977:165).

### Creating Community Feeling

Alexander *et al's Pattern 31 - Promenade* (1977:168) is used theoretically to develop and maintain a lively community atmosphere around the family of buildings such that creativity integrates with everyday life. People are able to walk with a destination in mind, being seen and watched all the while, which confirms community between people.

### Courtyard

The area's existing users are seen to have a keen affinity and interest in artistic practices and cultural pursuits. This attribute is furthered by Alexander *et al's* (1977:242) *Necklace of Community Projects* Pattern. In line with this theoretical base, The Imagination Station is seen to create and provide spaces for the artistic community to voluntarily meet so that their identity can be fostered and strengthened. Such a space is the courtyard, as well as the dining facilities.

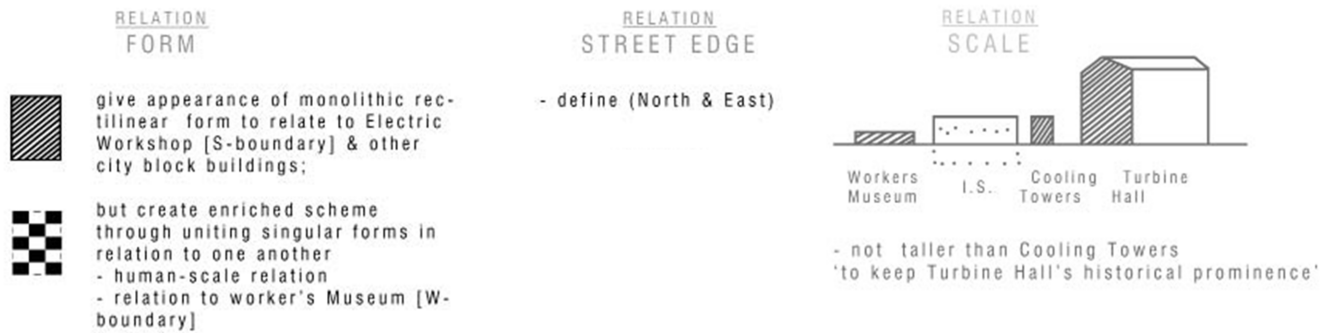

Figure 45: Preliminary Urban Response Diagrams [Author, 2013]

**NOTE:** Further Urban Response Diagrams follow in the Design Development Chapter

Legend

-  existing built-form
-  new architectural developments
-  new courtyards: public / semi-public / private
-  new kiosk retail
-  new Artisan Alley
-  redeveloped park - landscaped
-  redeveloped park - landscaped for appropriation
-  primary movement routes
-  secondary movement routes
-  new landscape architectural link
-  new basement parking portals - stairs & lifts
-  new 'pedestrian priority' finish to Miriam Makeba
-  new 'Gateway to Electrical Precinct' marker sites

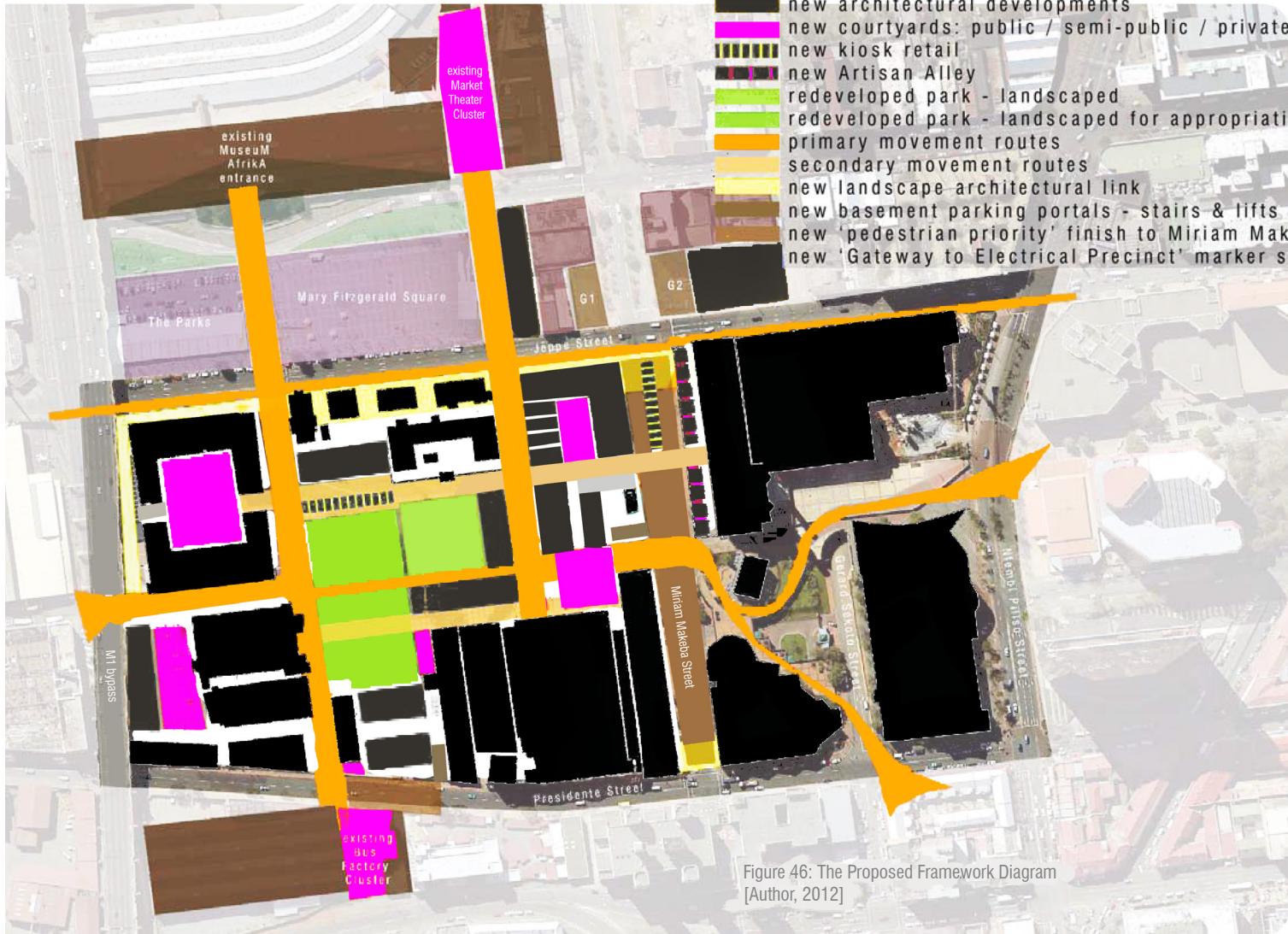

Figure 46: The Proposed Framework Diagram  
[Author, 2012]

## 3.10 Proposed Framework

---

### Introduction

The Framework developed from the mapping of the Newtown Electric Power Station Heritage Precinct as well as key principles from past proposed frameworks done by GAPP Architects and Urban Designers [2001].

### Diagram & Responses

The Framework Diagram best illustrates the scheme to which the architectural design responds. Newly proposed framework buildings can be seen in blue. The existing and proposed key movement routes were of primary concern in the development of the Framework. The Framework aims to unite the Electric Power Station Heritage Precinct; in terms of its cultural programmes, building stock and spaces.

Primary Framework Responses include:

- the need for definition of urban edges
- active edges; such that mixed use buildings are proposed: with active ground floors

leading to greater privacy thresholds for office and residential above.

- courtyards of differing natures - from public, to private to semi-private.
- means to articulate the cultural historic significance of the Newtown Precinct, while making way for contemporary means of living.
- Creating places for community engagement, recreation and relaxation in apprehension of the future residential component proposed in the Brickfields region.
- Pedestrian priority over automobiles.
- Safety and security; with current Newtown Management District guards having dramatically improved the safety of the area.

### Specifics

#### Newtown Diversity Park

The park is to be redesigned for improving its role, quality of space and what it facilitates for users. A section of the park will function as a community vegetable garden - manned by the homeless in order to provide themselves with food and livelihood. Food will also be grown to stock cafes and restaurants in the area. This is

in line with Alexander *et al*'s *Pattern Number 7* (1977:39) where regional parks are seen to be made into "working farms".

#### Existing Cooling Tower

It is crucial to keep the existing cooling tower and emphasise its importance since it is the last cooling tower in existence since the implosion of Newtown's larger cooling towers in 1985 [NHT, 2010:(online)]. As Alexander *et al* (1977:132) states:

"People cannot maintain their spiritual roots and their connections to the past if the physical world they live in does not sustain these roots."

The urban response includes creating a raised pond around the base of the elevated cooling tower to emphasise it as an object leftover from Newtown's Industrial Heritage. On a symbolic level, the water relates to the former process of evaporation that happened in the cooling tower in its original intended function. Now the water has condensed around its base and offers new opportunities for the contemporary precinct users.

This response also relates to Alexander *et al*'s theories (1977:135) of people's requirement to be near and/or interact with water. While adding another element to the community atmosphere of the Electric Precinct, the newly introduced water body simultaneously adds sustainable control in moderating the temperature swings of the microclimate.

The Framework proposes adaptively re-using the Cooling Tower Structure as an Immersive Musical Container to compliment the neighbouring immersive activities of the Sci-Bono Discovery Centre and the Creativity Centre.

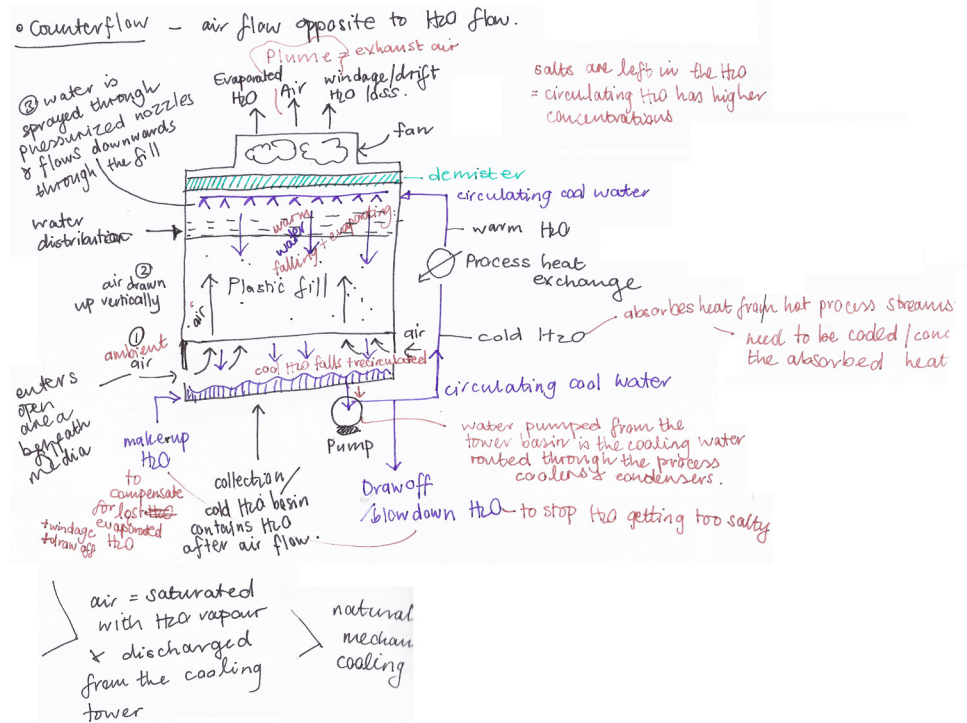

Figure 47: Understanding the former processes in the Cooling Tower [Author, 2013]

water body below cooling  
refers to its original functional use  
in a manner.

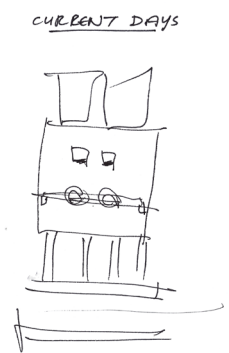

Figure 48: Former, Present and Proposed Uses of the Cooling Tower [Author, 2013]

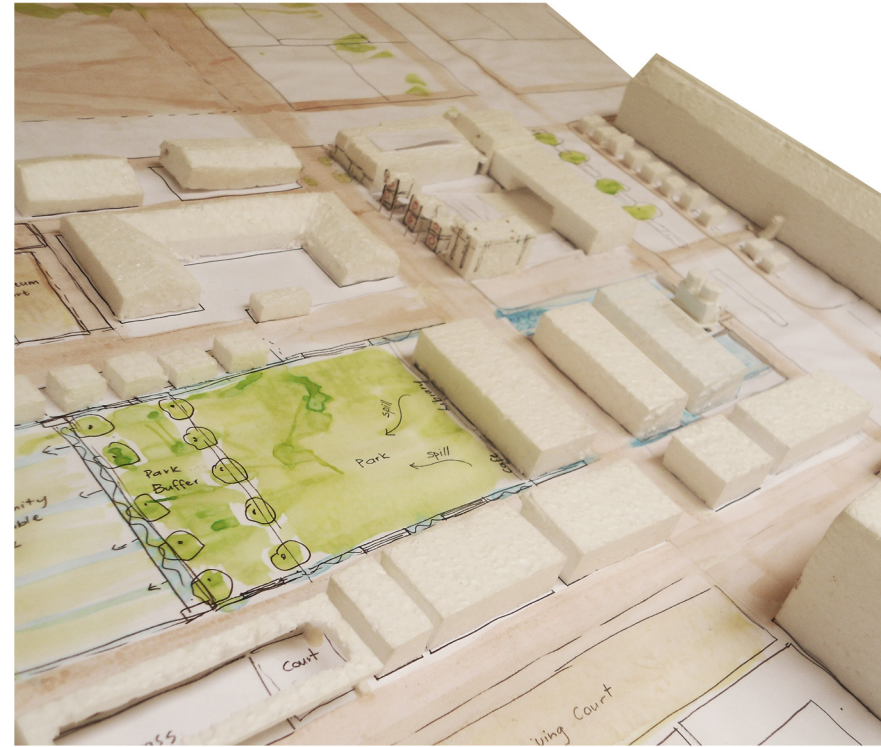

Figure 49: Model of Urban Response [Author, 2013]



## 3.11 Theoretical Architectural Response

### Sum of parts

The site plays host to a family of buildings creating a complex instead of a singular monolithic edifice.

The ‘family of buildings’ notion is mutually generated by the site conditions, the programme and urban theory of Alexander *et al*’s *Pattern Number 95 - Building Complex* [1977:469-471]. The singular building form is divided into zones to entice the public to use and passer’s by to be fueled by curiosity and become involved in its community programme by its more welcoming human scale. “A building cannot be a human building unless it is a complex of still smaller buildings or smaller parts which manifest its own internal social facts” [Alexander *et al*, 1977:469].

The mix of facilities in The Imagination Station create a lively environment in line with Alexander *et al*’s *Work Community* theory [1977:224]. The mix of work range from the artisans and artists doing small - to large-scale work respectively; to office administrators; to security, teaching and reception staff.

Each zone is tied together around the square on the common piece of land in the larger Newtown Cultural Precinct. Alexander *et al*’s theory is furthered with the Centre encompassing accommodation and food service facilities. “Build or encourage the formation of work communities - each one a collection of smaller clusters of workplaces which have their own courtyards, gathered round a larger common square or common courtyard which contains shops and lunch counters” [Alexander *et al*, 1977:225].

### Marketplace of Learning

The Imagination Station is a place for engaging with new ideas, which therefore relates to Alexander *et al*’s *Pattern Number 43* [1977:232] in terms of having places of learning designed along lines of a marketplace. This theory sees the physical structure as supporting the social structure - with a collection of small buildings along pedestrian paths.

Ideas are supposed to weave through the city with nodes of concentration at specific points [Alexander *et al*, 1977:233]. This idea is physically manifested in terms of The Imagination Station’s ‘Idea Interchange’ relation as further outlined in *Chapter 02 - Design Development*.

## URBAN RESPONSE: Creating a Network of Learning

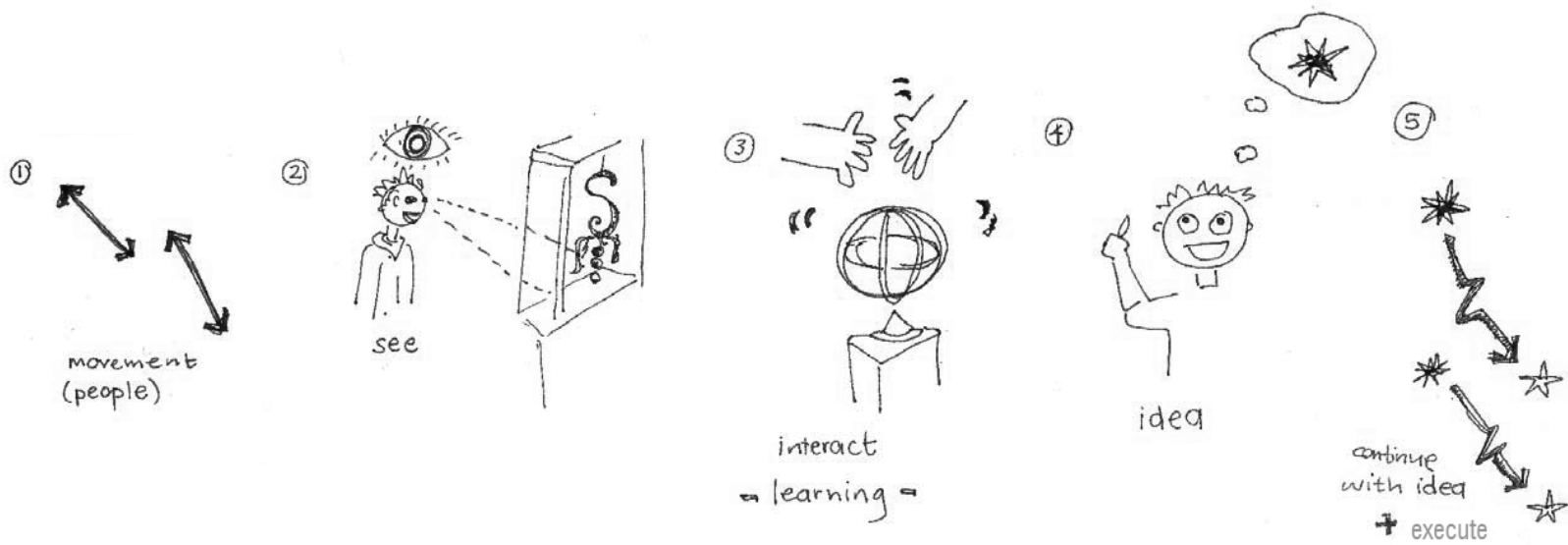

Figure 50: Architectural Response: Creating a Network of Learning [Author, 2012]

## 3.11 Programmatic Architectural Response

---

### Hierarchy

The Hall is seen as the main space. Hierarchy is articulated through the roof heights, prominence of placement and smaller spaces leading up to the main volumes. This relates to *Alexander et al's Pattern Number 99 - Main Building* [1977:487]. *Alexander et al's Pattern Number 114 - Hierarchy of Open Space* [1977:558] is also utilised in creating views from spaces into adjacent larger space(s).

Social mingling is encouraged in the Imagination Station through the provision of cafes to encourage people to stop and investigate the Centre further, while satisfying their basic need to eat. The courtyard encourages people to relax in a shady, secure space and watch the Centre's happenings. The courtyard is thus seen as a *Public Outdoor Room* [Alexander et al, 1977: 349-352].

### Courtyard

*Alexander et al's Pattern Number 101 - Building thoroughfare* [1977:494-495] states: "Public places are meant to invite free loitering. The public places in community building (city halls, community centers, public libraries) especially need this quality, because when people feel free to hang around they will necessarily get acquainted with what goes on in the building and may begin to use it."

■ 003 experimentation

sign

1.1 Introduction to Design Problem 1.2 Architectural Theory: *Gesamtkunstwerk* 1.3 Precedent Study

# 01 design problem

## 1.1 Introduction to Design Problem

---

### Introduction

The project advocates Jonathan Barnett's [1982:7] approach towards solving the site and programmatic problems, holding the view that:

“Design is a methodology that can help solve the problems of misallocated resources, mis-used space and the unnecessary destruction of history and heritage.” Such a stance is particularly relevant in Newtown’s historically sensitive urban context.

### Problem

The project’s primary design problem focuses on how to combine the conditions outlined in *Chapter 002: the[st]ory* into functional spatial forms. The generalised problem is how to design a centre responding to the programmatic aim of stimulating creativity. As the design development advances, secondary and tertiary design problems come into play.

### Means

#### Design Concept

The design concept (as elaborated in the following Chapter 2.3) is seen to guide all design decisions made in response to the encountered problems.

#### Architectural Tool Palette

The architectural tool palette is crucial to solving such design problems. Architectural elements such as light; texture; thresholds; rhythm and sensual engagement are all utilised in the exploration to solve the encountered problems; provoke emotion in the user and create a sense of place.

### Normative Position

The author’s normative position comes into play when addressing design problems. The author’s normative position calls for the design of meaningful spaces, accomplished through an outlook based on integrity. This translates into architecture promoting and facilitating creative expression, modes of existence and appropriation.

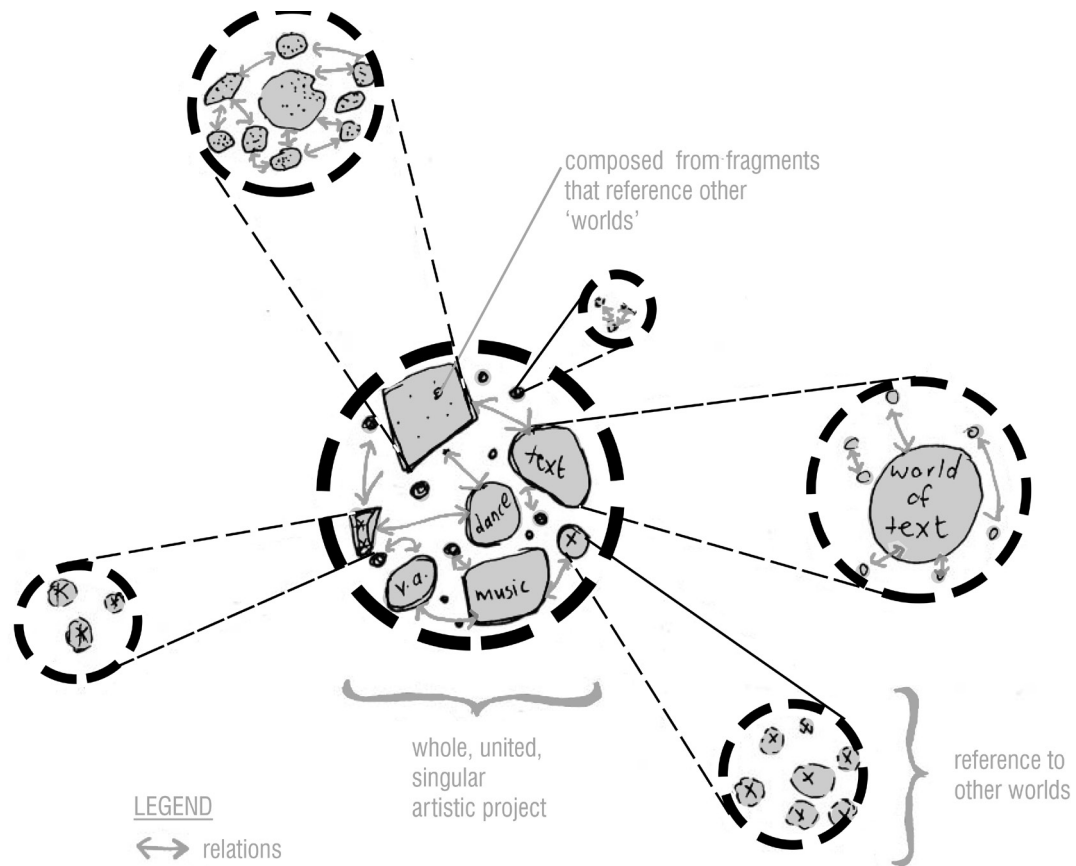

Figure 51: Fragmentation: *Gesamtkunstwerk*, seen as 'the total artwork', where a collection of parts are bound to one another to form a unified whole. Each singular part is seen to reference another 'system' with the combination of such disjointed assemblies creating a richer end product [Author, 2012]

## 1.2 Architectural Theory: *Gesamtkunstwerk*

---

### Theoretical underpinning: Influence of *Gesamtkunstwerk* on architectural design

It should be noted that in the context of the *Gesamtkunstwerk* theory, references to the generalised term of ‘art’ includes the specific sub-division of ‘architecture’.

#### Introduction

A general outline of *Gesamtkunstwerk* is first provided in terms of historical movements that endorsed and furthered its principles in Section [A]. The Elements of *Gesamtkunstwerk* and *Gesamtkunstwerk*’s Agenda are covered, as well as Architecture as Architecture as the ‘ultimate artwork’.

Section [B] follows the initial outline with the dissertation’s stance on *Gesamtkunstwerk* principles in relation to the proposed project.

### [A] *Gesamtkunstwerk*

#### Etymology

The term *Gesamtkunstwerk* is derived from the components of *samemen* ‘to assemble, gather, collect’ [Finger and Follet, 2011:5]; *kunst* translated to ‘art’ and *werk* translated to ‘work’. These definitions combine to constitute ‘the assembled artwork’; which is expanded upon later in the chapter.

---

#### Historical Conception

The Eighteenth Century Romantic Period associated conceptual notions with *Gesamtkunstwerk*, while the term was only formally conceived by Karl Trahdorff in 1827 [Finger and Follet, 2011:2]. Richard Wagner brought the term to prominence with his writing *Art and Revolution* [1849]. Wagner’s text proposes fusing art forms for a more potent artistic experience; as well as the amalgamation of art with life [Finger and Follet, 2011:10].

### Elements of *Gesamtkunstwerk*

1. *The collection of different parts to form single unified aesthetic project*
2. *Fragmentation*
3. *Borderlessness*
4. *Chance*
5. *Impossible Realisation*

1. The collection of different parts to form single unified aesthetic project

*Gesamtkunstwerk* is formally regarded as ‘the total artwork’ as it is the gathering and synthesising of varied elements to form one ‘all-inclusive’, united project [Finger and Follet, 2011:2]. Anke Finger and Danielle Follet [2011:2] further this definition by stating that *Gesamtkunstwerk* often “describes an uneven cluster of aesthetic elements that can be regarded as common to some quite disparate artistic endeavours”.



In the creation of a *Gesamtkunstwerk* project, typical boundaries are often transgressed through the act of collection and synthesis. A “decentralized, open, dynamic space of encounters between many disparate elements and participants” may therefore come into being [Finger and Follet, 2011:6]. This ‘openness’ is often sought for its allowance of alternative experiences to come into play.

*Gesamtkunstwerk* is seen to support the notion that ‘the whole is more powerful than the sum of its parts’ [Stavrinaki in Finger, 2011:264]. Theorists regard the separation of different forms of art to cause such elements to be isolated, artificial and often insipid; with little relation to everyday existence, habits and context [Finger and Follet, 2011:6].

The opposing critique of ‘the artwork of everything’ views the synthesising of different art forms to compromise the individuality of the components. The potency of individual elements is seen to be lost; along with that of the user’s experience [Finger and Follet, 2011:6].

## 2. Dispersion | fragmentation | deconstruction | disintegration

The inherent aspect arising out of assembling diverse elements to create a whole, is the relation of dispersed fragments to one another and the whole. Walter Benjamin [in Stavrinaki in Finger, 2011:271] analyses this act of collecting as a way of reconciling the world, which is seen to be comprised of confused displacement, with a fight against ‘dispersion’. The act of consciously gathering the fragments that reflect dissonance can be viewed as an act of ‘salvation’ [Finger and Follet, 2011:22].

### Principles relating to fragmentation

A plethora of theories recounting ‘the fragment’ and its relation to ‘the absent whole’ arise. Such theories perceive that:

2.1. In fragmentation, as a form of separation from wholeness, a fragment’s inherent ‘nature’ is strained [Finger and Follet, 2011:9].

2.2. The fragment itself can become defragmented when it breaks from the whole, such that it becomes completely separated from the missing or renounced whole: thus fundamentally making up the loss from the whole in a certain sense [Finger and Follet, 2011:9].

2.3. Fragmentation is seen to articulate the whole that is absent, in such a manner that the entirety of the construct is felt both in presence and absence. The power of gathering to create the whole is felt in each component referencing a whole other system, while being separated from the system, and combining with references to other systems to create ‘a total work’. The transgression of system boundaries therefore gives the construct its potency [Finger and Follet, 2011:9]. [Refer to Figure 51 on page 93].

2.4. The apparent disorganisation created through grouping fragments, ironically references organisation in the creation of a whole; such that the antithesis can call the actual construct into being. This play creates a ‘total’ artwork in itself – through inversion of the norms of unified fragmentation [Finger and Follet, 2011:10].

### The Fragment's relation to the Art of *Gesamtkunstwerk*

Absolute *Gesamtkunstwerk* can be viewed as a 'middle state' of 'altered perceptions' intersecting with life. It is both reflecting on the world and in the world – it is both a fragment in the world and a whole in itself. It thus transgresses boundaries to create a portal into an alternative dimension of worldly experience; bringing facets that are generally hidden to perception. *Gesamtkunstwerk* is therefore seen to create new ideas and paradigms [Finger and Follet, 2011:10].

#### Example

The instillation, *Dump* [2008] [refer to Figure 52 on page 96], by artist Christoph Buchel at the Palais de Tokyo, France, provides an apt example of *Gesamtkunstwerk* principles. Through the instillation comprised of a heap of debris, the "aspiration towards unity [can be sensed], even if that unity can never be fully achieved. Paradoxically, it is in the self-conscious and ironic awareness of limitation that one may have an experience that is even more

total, since this encompasses imperfection itself within a larger frame" [Finger and Follet, 2011:24].

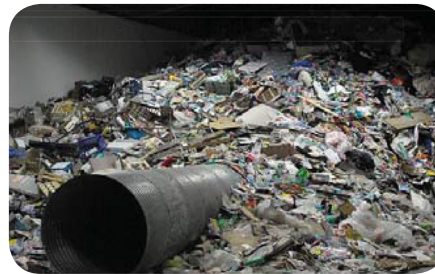

Figure 52: Entrance to Buchel's *Dump* instillation. Safety helmets are mandatory; with a maximum of two visitors entering simultaneously [Hauser & Wirth, 2012]

### 3. Borderlessness

*Gesamtkunstwerk* as "an aesthetic ambition towards borderlessness", is seen to play against the notion of the fragmented whole [Finger and Follet, 2011:3]. Borderlessness is viewed as an 'open entirety' that is unfinished and can only aim at reaching entirety through its continual dynamic development past its prior confinements. Borderlessness can further, or contradict, the *Gesamtkunstwerk* that relies on the assemblage of elements for the construct of relations for a united or disjointed whole [Finger and Follet, 2011:5].

Borderlessness relates to the totalising nature of *Gesamtkunstwerk*'s programme in its specific aim of combining and setting off elements within the construct of three specific contexts [Finger and Follet, 2011:4]:

3.1. The merging between various forms of art; as well as in each form's genres.

3.2. Merging artistic creativity with politics and philosophical critique. Art is seen to be a vital

component as a part of everyday life; such that easy creative engagement should be facilitated. It has been seen historically that the world of art has been the starting point for expansion. The key is artworks that give more to the world than fulfilling their own egotistical means; as well as works that push the boundaries and limitations of art itself.

3.3. An aspiration towards metaphysical borderlessness is embodied. This is seen through bridging the pragmatic present with the fantasised future aspiration of totality. Such aims are seen in a spiritual light of 'salvation'.

#### 4. Chance

The 'aesthetics of chance' are motivated in *Gesamtkunstwerk* through the principle that "the planned incorporation of unplanned elements, or the advertent use of inadvertence" will lead to a greater 'opening up' of the artwork. Incorporating such elements of 'chance' allows 'possibility' to come into play. Possibility provides the potential for the idealistic aspiration

to be completed: with the total artwork opening up to 'infinity' through such possibility. Set, fixed elements without the possibility of appropriation would bring about completeness and an end to the project instead of such openness and potential for expansion [Finger and Follet, 2011:22].

#### Dada-ist Relations

The Dada movement of the 1920s demonstrates an amalgamation between different art forms, as well as the incorporation of chance into artworks and performances. Such was spurred on in reaction against the logical rationality that was viewed to have resulted in World War One. "The use of chance yields an absolutely open totality through infinity... [the] indirect or negative path toward totality, often ironic or self-consciously aware of imperfection and in which 'anything' comes to stand in for 'everything'" [Finger and Follet, 2011:23].



Figure 53: Dada Artist Jean Arp: Squares Arranged According to the Laws of Chance [1917; cut and pasted papers, ink and bronze paint][MOMA, 2012]

## 5. Impossible Realisation

“The early romantics...dreamed of an unachievable totality in the process of constant becoming, without hierarchy or stability” [Finger and Follet, 2011:8]. Such is shown that from the roots of *Gesamtkunstwerk*, the ambitions of the ‘totalising project’ were always set too high, out of the project’s own physical limitations. Yet it is this unachievability that keeps the ideas behind *Gesamtkunstwerk* constructs alive – always out of reach, yet defining a goal towards which to strive. The goal, not the realisation, propels *Gesamtkunstwerk*. “For to leave the work incomplete and to voluntarily defer its execution are ways of keeping the idea alive, of refusing the reification of totality and the fetishism of the absolute within a finished work” [Schefer in Finger,2011: 35] .

This utopian character is illustrated by Frenhofer’s painting in Balzac’s 1837 short story *The Unknown Masterpiece*. The story relates to the artwork as “- both failure and work of supreme art - the total artwork seems paradoxically destined to succeed perfectly only by failing or to fail by succeeding too much” [Schefer in Finger,2011: 35].

## How *Gesamtkunstwerk* comes to be: World in Crisis: Fragmentation and Alienation of the Modern World

“The very notion of the total artwork cannot be separated from a world crisis and the expectation of an artistic redemption. The project of the unity of the arts, then, was also proposed as the symbolic healing and mending of a modernity that was frequently charged with egoism, individualism, and materialism” [Schefer in Finger,2011: 32].

As well as aiming to address the fragmentation and alienation of the modern world, *Gesamtkunstwerk* seeks to unite humanity with nature in pure metaphysical completeness. Olivier Schefer [in Finger,2011: 32], however, deflates such aims by stating: “the total work of art could perhaps be defined more fully by the crisis it presumes and prolongs than by any mythical resolution that it pretends to bring to that crisis.”

## *Gesamtkunstwerk*’s Agenda

1. *Art merged with Life*
2. *Art as a Social Transformer: Artistic Revolution | Redemption*
3. *New Artistic Paradigms*
4. *The Role of the Participant*

### 1. Art merged with Life

*Gesamtkunstwerk* calls for artistic practice to become integrated with everyday existence. This notion was a part of *Gesamtkunstwerk*’s Romantic Period’s founding ideas, as expressed in *Fragment 116* of the Schlegel brother’s *Athenaeum* [1798]:

“Romantic poesy [creative undertaking] should blend and merge the poesy of art with the poesy of nature, give life to poesy [creativity] and render it sociable, make life and society poetic” [in Finger and Follet, 2011:3].

---

## 2. Art as a Social Transformer: Artistic Revolution | Redemption

*Gesamtkunstwerk* recognises the power art holds as a means for directing social reform. Carl Einstein [in Finger and Follet, 2011:13] states that reform gives purpose to art, which is otherwise simply aesthetic: “With this goal, art can find its place again, if it humbly participates in the production of a new reality.”

Art therefore needs to operate from a base of integrity, through ‘spiritual wholeness’. When a true work of *Gesamtkunstwerk* is mastered, ‘sociopolitical liberation’ is tasted [Finger and Follet, 2011:13].

## 3. New Artistic Paradigms

Past expressions of *Gesamtkunstwerk* have envisioned ‘the total artwork’ to embody ‘a new religion’ through communal expression [Finger and Follet, 2011:11]. Such an outcome is achieved through the combining of disciplines as prompted by artists pushing

conceived boundaries and exploring new ways of artistic theorising, production and user experience. As Finger and Follet [2011:23] reiterate: “...the embrace of the total artwork in its multifarious forms has been a catalyzing force through which artists from a myriad of artistic disciplines have freed themselves from the constraints of traditional artistic thinking, a springboard for the invention of new forms and new hybrid genres that celebrate the dissolution of ‘arbitrary’ divisions between the arts.”

## 4. The Role of the Participant

*Gesamtkunstwerk* calls on the once passive spectator to become an active, engaged participant. This is so that people relate to the experience on a conscious level, beginning to analyse, reflect and question for themselves [Finger and Follet, 2011:18]. This notion reiterates the sociopolitical nature of *Gesamtkunstwerk* acting as a seed which is planted to inspire more out of the spectator.

Finger and Follet [2011:18] state that works of *Gesamtkunstwerk* often “attempt to stretch the limits of the capacity for conscious perception through the simultaneity of diverse stimuli and to purposely forestall the possibility of a primary analytical/intellectual relation with the work.” *Gesamtkunstwerk* can therefore be seen to strive for complete experiential immersion and rapt engaged participation [Finger and Follet, 2011:18].

---

---

## Architecture - conducting the 'ultimate artwork'

Historically, architectural design was seen to be 'the ultimate art form'; "an art that unifies everything" [Stavrinaki in Finger, 2011: 258]; the conductor of the orchestra comprised of other arts such as painting, music, performance and furniture design. In terms of *Gesamtkunstwerk* historically, architecture was viewed as the instrument to facilitate and liberate the other art forms [Stavrinaki in Finger, 2011:258].

---

### Case Studies relating to Architectural *Gesamtkunstwerk*:

1. *Expressionist Architecture [1910-1930]*
2. *Cubism [1908-1914]*
3. *The Bauhaus [Weimar :1919-1924; Dessau: 1925- 1932; Berlin: 1932-1933]*
4. *De Stijl [1917-1931]*
5. *Merzbau [1923-1937]*

## General Context of Case Studies | Reincarnation or Revolution

After the First World War [1914–1918], artists questioned artistic practices and art's relevance to the society of the time. The Dadaists viewed pre-war art as an elitist, 'bourgeois invention' which was scorned for embodying individualistic desires and lack of relation to 'the people' [Tsai in Finger, 2011:279]. Sandor Barta [Tsai in Finger, 2011:280] declared that art should only be permitted to exist if it served revolutionary ideals and not that of elitism.

Stavrinaki [in Finger and Follet, 2011:253] recounts how art had battled against its diminishing power for the previous two-hundred years; as belief in art is commonly linked to belief in religion and politics. People had begun to question religious and political dogmas with the rise of Modernity. Art and Architecture are seen to progress through re-inventing themselves to adjust and reflect the spirit and ideals of the era – be it in terms of advocating or opposing such ideals. This

incarnation is seen to be embodied through art's sensuous means and personification of spiritual 'divine'. With wavering belief in Christianity, belief in the divine also wavered.

Stavrinaki [in Finger and Follet, 2011:253] continues by elaborating on how artists viewed their work to fuel new visions for the future - for an improved society "–or at least as sources of energy that could be mobilized toward the construction of such a future collectively". Art, once "the fruit of a new religion" now had "to be the seed of one; it has not only established the dogma of a new religion but has often presented itself as such a new religion's first incarnation" [Stavrinaki in Finger and Follet, 2011:253]. As stated in the *Proletkunst* manifesto: "Art is a spiritual [*geistige*] function of the human and has the purpose of redeeming the human from the chaos of life" [Stavrinaki in Finger, 2011:270].

## Specific Architectural Relation

Bruno Taut's writing for *A Program for Architecture* [in Stavrinaki in Finger, 2011:260] describes the disruptions of the time including the dispersion of the arts and the resultant problems: "For lack of religion, these ages produced theories and 'abstractions', for lack of organic ties, they cultivated dispersion, formalism, and the spirit of negation; for lack of faith, they sowed doubt and cultivated irony."

Architecture was seen to have a purposeful role of 'tutoring' the other art forms [Stavrinaki in Finger, 2011:262]. Key movements and schools, such as the Bauhaus and De Stijl, believed that change in the world could only be derived by profoundly reconstituting 'sensuous perception' [Tsai in Finger, 2011:281].

As Adolf Behne [in Finger, 2011:262] states: "If there is a strong architecture that erects creations that arouse general attention, all arts are unconsciously influenced by it in the sense that finally their sense of communality [*Gemeinsamkeitsempfinden*] becomes more powerful and the memory of the originary [*sic*]

unity ascends once more." Behne continues, "unite and thus liberate...liberate by connection...[liberation] must direct the existence of the human being in society" [Stavrinaki in Finger, 2011: 263].

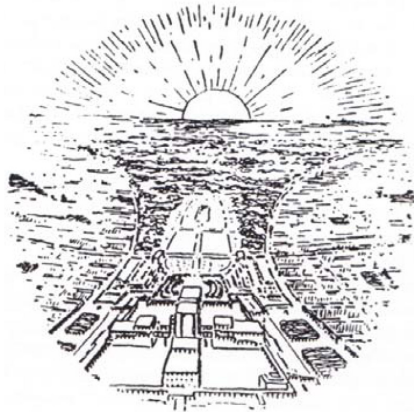

Figure 54: Bruno Taut: *Die Stadtkrone* [The Crown of the City], 1919, depicts the new era of spiritual enlightenment orchestrated by the new architectural agenda [Laboratorio, 2012]

## 1. Expressionist Architecture [1910-1930]

The Expressionist Architects sought to embody a new 'spiritual revolution' through 'organic unity' in their utopian architectural proposals [Stavrinaki in Finger, 2011:253-4]. Such ideals were put forth by *The Work Council for Art* [*Arbeitsrat für Kunst*, Berlin 1918]. Its two main goals sought to unify the different art forms and unite art with 'the people' [Stavrinaki in Finger, 2011:254].

As the first president of *A Program for Architecture*, Bruno Taut sought to fuse the goals put forward by *The Work Council for Art*. Taut [in Finger, 2011:255] states: "The various disrupted tendencies can find their way back to a single unity under the wings of new architecture, so that every individual discipline will play its part in building. Then there will be no frontiers between the applied arts and sculpture or painting. Everything will be one thing: architecture. The direct carrier of the spiritual forces, moulder of the sensibilities of the general public, which today are slumbering and

tomorrow will awake, is architecture. Only a complete revolution in the spiritual realm will create this architecture. But this revolution, this architecture will not come of themselves. Both must be willed – today’s architects must prepare the way for tomorrow’s buildings. Their work on the future must receive public assistance to make it possible.”

Expressionist Architects believed that architecture should visually demonstrate and be the physical manifestation of the victory of the spiritual revolution. A Program for Architecture calls for the collaboration of artistic forms - with studios and building sites accommodating such means. Painters and sculptors were to be fully integrated in the development of architecture, such that their art becomes more than ‘insignificant’ ‘salon art’ [Taut in Finger, 2011:262].

Gropius [in Finger, 2011:257] reiterates the role of architecture to articulate the new spirituality: “The final goal of all form-giving activity will be the building... A great work of art of the people, a cathedral of the future, will be the symbol of a great spiritual idea, and this work will radiate out even to the most exiguous objects of everyday life... we very much want to be the precursors, the first instruments, of a new, common way of thinking.”

Germany’s socio-political *November Revolution* [1918-1919] was seen by Taut to be the background needed for artists and architects to forge a spiritually ‘new context’ [Stavrinaki in Finger, 2011:256]. Although the revolution was seen to be spurred by class-struggle inequalities, Expressionist Artists and Architects held the opinion that ‘the masses’ would never see the value of a revolution of the spirit over the revolution of daily reality [Stavrinaki in Finger, 2011:256]. Gropius [in Finger, 2011:257] states that professionals, embodying ‘higher understanding’, need to direct the spiritual revolution for ‘the people’ as meaningful change was misunderstood and misdirected by the general population: “If art can no longer be the flower of the organic totality, it has to become the seed; if it can no longer be the product of the people, it has to become its producer.” The spiritual revolution “was to result in a vision of the world that would renew the coherence of human society. While the agent of the political revolution had been ‘the masses’, that of the spiritual revolution would be ‘the people’” [Stavrinaki in Finger, 2011:256].



Figure 55: Erich Mendelsohn: Einstein Tower, Potsdam-Berlin, 1919-22, illustrating the new architecture of the Expressionist Architects embodying a new spirituality [Hollingsworth, 1988]





Figure 56: Pablo Picasso: Still Life with a Bottle of Rum [1911, Oil on canvas] displays fragmented facets combining to create a greater, over-all holistic, united composition [MET, 2012]

## 2. Cubism [1908-1914]

The proceeding summarised analysis of works from the Cubist Art Movement illustrate the most commonly-held readings of Cubism:

1. Cubism unconsciously aspires to unity. Unity was achieved through fragmented planes, as constructed forms, merging to one unified aesthetic. Cubism therefore achieves construction of a 'total artwork' [Finger, 2011:258].

2. Cubism is seen as the one art that stands closest to that of architectonic means in its very essence and physical goal [Stavrinaki in Finger, 2011:259]. Stavrinaki [in Finger, 2011:258] refers to all other art forms as 'unactualised products' always aiming towards that of architecture: "the other arts are but incomplete architecture, a protoarchitecture whose only goal is 'true' architecture. As Taut writes, everything tends toward a 'total art whose most profound essence is architecture.' In a very Hegelian sense, total art is thus defined as architecture having gained consciousness of itself."

3. The unity in Cubism references the aspiration for unity between the subject and the world; in an act of promoting social unity. Reading of the constructed work is furthered by the work being seen "to carry the whole and to liberate the visual artist from his isolation, to embrace him lovingly, connecting to and thus liberating him" [Stavrinaki in Finger, 2011:258].

### 3. The Bauhaus [Weimar :1919-1924; Dessau: 1925- 1932; Berlin: 1932-1933]

In The Bauhaus *Founding Manifesto* [1919], Walter Gropius articulates the aims and beliefs of his Expressionist Architectural ideals. The Bauhaus School sought to embody and promote the proceeding ideals [in Finger, 2011:281]:

1. The goals set out in the manifesto aimed to re-address the escalating requirement for specialisation in the modern age, at the end of the Second Industrial Revolution.
2. Craftsmen, architects and artists were encouraged to unify and strengthen their craft alliance.
3. A new community would therefore be created through the communal, pragmatic act of construction.
4. Such was seen to be a total project of aesthetic unity: resulting in a *Gesamtkunstwerk*.
5. The base of a social utopia was thus formed.

### 4. De Stijl [1917-1931]

As with the Bauhaus, De Stijl viewed the act of construction to be the uniting force between different forms of art: “Instead of developing in isolation from one another, the arts must find material manifestation in a constructive and inherently integrative architectural project. Building would subjugate the arbitrariness of individual’s subjective impulses and thereby produce ‘an objective universal means of creation’ that would come to offer, at least in theory, the space within which the arts would converge to find unified expression” [in Finger, 2011:281].

In terms of artistic expression and development, De Stijl believed that the process of first simplifying each art form to its essence through methodical investigation; followed by combining the purified, most important elements “to constitute a new non-mimetic, universally valid aesthetic vocabulary” should be followed. ‘Pure plastic expression’ is thus achieved through the process [Tsai in Finger, 2011:281].



Figure 57: The Reitveld Chair [1918] by Gerrit Reitveld is seen to reduce the chair form to its pure functional essence, for a new architectural vocabulary typical of the concerns of the De Stijl movement [Hollingsworth, 1988]

Figure 58: A Bauhaus teapot design demonstrates the new preoccupation for all Architectural project components to be designed - from the macro to micro scale [Hollingsworth, 1988]



## 5. Merzbau [1923-1937]

Dada artist, Kurt Schwitters, three-dimensionally 'collaged' the inside of a number of his apartments by gathering and utilising discarded building rubble left from the First World War. Architectural forms were then re-constructed in a new unity within the boundary provided by each apartment [Refer to Figure 8].

Schwitters' constructed environments reflect *Gesamtkunstwerk* in terms of a 'total artwork' being created through the means of gathering disparate fragments, which are then placed in relation to one another to create a new unity. "The consciousness of destruction, fragmentation, and contingency, which combined with the desire to invite into his home everything and anything, yields a new form of total artwork, one that takes a more indirect route, perhaps, toward totality" [Finger and Follet, 2011:21].

Schwitters' works can be seen to bring coherence to the uncontrollability of the world, through very particular, yet tacit, means. As

Stavrinaki [in Finger, 2011:271] states: "even if Schwitters desires to extract these signs of the tragic from their negative states in order to situate them in the controlled 'totality' of the work of art, he nonetheless does not erase the destruction that is an inherent part of what is uncontrollable about the world." A totalising, immersive environment with acute contemplative power is created in the Merzbau, "since it absorbs and envelops the spectator within it, in a silence that is often described by its visitors" [Stavrinaki in Finger, 2011:274].

Figure 59: [left] Kurt Schwitters' Merzbau constructions made from fragments left by the First World War [II MERzbau, 2012]

## [B] The Imagination Station

### Relevance of *Gesamtkunstwerk* theory to the Dissertation's Architectural Design

#### Introduction: The Dissertation's play on *Gesamtkunstwerk*: Impossible Realisation

Theoretically, a dissertation is always a work of *Gesamtkunstwerk* as it will always seek to be what it proposes, yet since it is a dissertation, it will never reach realisation and thus always aim to be more than it is permitted to be. Already, in its essence, without any 'founding principles' relating to *Gesamtkunstwerk* being displayed in the architectural design, the dissertation proposal is a work of *Gesamtkunstwerk*.

"The concept as such remains scripted but unrealized, unfinished, 'unfinalizable', immaterial, and utterly alive, an idea that inspires and enrages and that projects new and possible forms of art, whether they are to be

realized or not. It retains its historical contingency in that formerly proposed scripts for a total artwork may be taken up repeatedly by different disciplines and arts in order to be modified, probed, redefined, and reissued" [Finger and Follet, 2011:23].

#### Programmatically

The dissertation embodies *Gesamtkunstwerk* programmatically as a 'hosting institution' [Finger and Follet, 2011:4] for the immersive experiential synthesis of art with life - in the search of creating a greater 'totality'.

#### Architecturally

The Imagination Station is conceptually developed according to *Gesamtkunstwerk* principles: in terms of its building form being constituted from different functional components, arranged in a creative unity. This concept is elaborated upon and depicted in the proceeding *Chapter 02 - Design Development*.

#### Architectural Relation to *Gesamtkunstwerk* Principles

##### 1. The collection of different parts to form single unified aesthetic project

The Imagination Station building functions are seen to be individually expressed and accordingly fragmented in form; while creating a united whole in their total contribution. The unenclosed, negative spaces [such as the courtyard] articulate the functions of the positive spaces. Relations between the functions, in their individual, fragmented forms, will provide depth, energy and potency to the encompassing space.

##### 2. Fragmentation

Through the united collection of different fragments, The Imagination Station embodies *Gesamtkunstwerk*. Functions in the Centre thus simultaneously present themselves as a whole and as fragments. The Centre is experienced as both an 'open' and a 'closed' totality.

The Centre is 'open' in its public permeability; 'closed' when the individual user becomes engulfed in the Centre's activities and is oblivious to happenings in the greater external world. "The *Gesamtkunstwerk* thus can present itself simultaneously as a whole and a fragment, as a closed and an open totality" [Finger and Follet, 2011:9].

Additionally, The Imagination Station is both a fragment in the greater Newtown Electric Power Station Heritage Precinct; and a whole embodied by the Creativity Centre itself.

Kurt Schwitters' previously illustrated Merzbau constructions [page 84] can be seen to hold relevant connection to the cultural heritage of the Newtown precinct as he creates unity from fragmentation: with the consciousness of creating from destruction [Finger and Follet, 2011:21]. Such is relevant to the case of Newtown's Electric Power Station Heritage Precinct: as the history of the past, of the electrical precinct's memory, building demolition, and societal forced removals can be expressed as much in their absence as to an intervention that makes direct physical reference to them.

### 3. Borderlessness

"In a text yet unpublished, written sometime in 1921 or 1922, Walter Gropius links the destiny of the Bauhaus to that of Germany, even to the fate of Europe as a whole. He recalls that the founding of the Bauhaus was contemporaneous with what he calls the German 'catastrophe', that is to say the defeat in the war as well as the November Revolution. The mission of the Bauhaus was to heal this double wound that the nation was suffering from" [Stavrinaki in Finger, 2011:264-5]. In a similar stance, Newtown relates to Johannesburg and Gauteng, in advocating a core Creativity Centre to stimulate creative urban acupuncture developing in the greater Johannesburg context such that creativity merges with everyday existence.

### 4. Chance

Architectural elements and/or volumes for curation and community engagement facilitate programmatic chance through allowing appropriation to develop in the Centre. Such chance appropriation will be inspired by artistic programmatic facilitators and left up to the community and/or users to develop further.

Chance elements allow for the design to never be completely finished - in order to keep the *Gesamtkunstwerk* theoretical manifestation, as well as the pragmatic use of the place alive.

### 5. Impossible Realisation

Finger [2011:8] describes the aspiration for new unity as inseparable from "the consciousness of its possible unrealizability [*sic*], its ever-unfinished state." The dissertation's design therefore provides the architectural shell, but will be unrealised until the user and/or curator brings their own agenda to the space. Once that agenda is brought and appropriation happens, then the agenda will evolve and change. The agenda will continually be reshaping itself in terms of reaching finalisation and perfection that will never actually be achieved. It is the search and journey for the always unrealised end goal that enforces 'the total artwork'.

Even if the project was constructed and functioning, in its very theoretical nature, it would always be searching for more... more individuals to influence: to spread the message of integrating art with existence to further users. "If the history of the total artwork is a succession of disappointments, of sketched yet aborted forms, this is due less to material constraints than to a certain understanding as to the relation between myth and real history, between the ideal and the existence itself" [Schefer in Finger, 2011: 35].

## Programmatic Relation to *Gesamtkunstwerk*

### 1. Art merged with Life

1. The Imagination Station acts as an urban acupuncture node to provide a point to start merging creativity into daily consciousness.
2. The building design is to act as an advertisement to promote architecture that facilitates and promotes creative modes of existence.

### 2. Art as Social Transformer: Artistic Revolution | Redemption

The dissertation's Architectural Aim, as a social director, is to create a meaningful place, that empowers its users to become more creative and act on such creativity. *Gesamtkunstwerk*'s aims can be seen to embody revolutionary utopian ideals for social transformation; which are viewed as overly idealistic for the current dissertation. Additionally, it is seen that South Africa is not in a position for such radical notions at this point in its history: "I don't think too much of such revolutions, humanity has to be mature for this kind of thing..." [Stavriniaki in Finger, 2011:269].

#### Limits

This dissertation sets the limit of not utilising *Gesamtkunstwerk* theory as far as its historical notions calling for 'artistic revolution and redemption'. The Third Industrial Revolution has been seen to put the world in crisis in terms of the background provided in *Chapter 002 - Conditions* of this dissertation, yet it is not the aim of this dissertation to solve the complete crisis. This dissertation provides a point of

acupuncture, in a specific, finite context, to the problem, through the means of a building formed by notions of *Gesamtkunstwerk* and with an agenda based on ideals of *Gesamtkunstwerk*. It looks more to the needs of the direct urban context than to the global problem.

### 3. New Artistic Paradigms

The 'artistic paradigm' of 'immersive artistic environments' that has currently been explored to a greater degree overseas and is explored in the totalising Creativity Centre programme in the South African context.

The dissertation's idealistic aim can be seen through relations to Hans Ulrich Obrist's 2003 Venice Biennale construction 'The Utopia Station': "...a vision of art-event creation that explodes the boundaries of both place and time, in continual construction and modulation, the Utopia Station is perhaps the dispersed yet 'gathered artwork' par excellence, as it consists of a series of encounters and re-encounters among a fluid and open group of participants and publics" [Finger and Follet, 2011:24].

---

### Artistic Stimulus to form 'new'/infrequently experienced Realities

Laszlo Moholy-Nagy [in Finger, 2011:288] believed that humans are 'entities made up of physiological mechanisms (*Apparate*) that could be honed to optimize their performance (*Leistungen*) through the appropriate application of stimuli (*Regung*).’ The dissertation’s thought-provoking, creative programme would ideally make users realise what talents are inherently inside them for unlocking [in terms of their possible outputs to the world to creatively express themselves for self and worldly benefit]. The creative experiences and experiments facilitated by the building aim to bring this knowledge to the user’s comprehension.

### 4. The Role of the Participant

As with *Gesamtkunstwerk* notions, the participant is actively engaged in the Centre. Users become engulfed in the architecturally constructed environments and programmatic stimuli for new levels of creativity to be reached.

#### *Gesamtkunstwerk* Conclusion: Twenty-First Century Relevance

As Finger [2011:25] states, the contemporary reading of *Gesamtkunstwerk* is of a “chaotic embrace of disjunction: a fertile dissonance”. As expressed in *The Imagination Station*, it is the aim of bringing together disparate parts for an improved assembly that unifies and creates ‘the total artwork’.

## 1.3 Precedent Study

---

### Introduction

As Marius Snyders [2011:104] states in his 2011 Architectural Dissertation: “A precedent should be studied to stimulate the designer, whilst informing the design process through specific qualities and aspects.” This outlook is true to the project; as the list and qualities of precedent studies changed and adapted as the project’s agenda and design process evolved. One of the first precedents studied, was The National Museum of Australia for its successful creation of an alternative architectural environment constituted through playfulness and delight. Further precedents follow in the design development and technification chapters. An in-depth essay analysis was completed on the Marketplace typology - for its representation of a flexible place of exchange - as the Creativity Centre was seen to embody such a place of ‘creative exchange’. Finally, technical precedents explore material expression.

### List of Precedents Studied

<i>Precedent Name, City, Country</i>	<i>Developmental Stage Investigated</i>	<i>Relevance/Generators</i>
[1] National Museum of Australia, Canberra, Australia	Theoretical Exploration	<i>Gesamtkunstwerk</i> , form making and approach to materiality
[2] Santa Maria Caterina Market, Barcelona, Spain	Typological Exploration	Programmatic form-making; layout; movement; organisation
[3] ‘La Pescheria’: Treviso Fish Market, Treviso, Italy	Typological Exploration	The creation of a united offering through singular functions [ <i>Gesamtkunstwerk</i> ]
[4] Victoria Street Market, Durban, South Africa	Typological Exploration	Community building through activities
[5] Wits Art Musum [WAM]	Design Exploration	Corner Art Gallery; aim to express programme
[6] Off-shutter concrete	Technical Exploration	Material expression





Figure 60: [left] Aerial view of the Museum layout forming a new waterfront at the end of Canberra's Acton Peninsula [ARM, 2012]  
 Figure 61: [below centre] Details of historically relevant wording incorporated into the walkway surface finish [ARM, 2012]  
 Figure 62: [below right] The articulated mix of materials, include braille-worded anodised aluminium panels [Author, 2003]

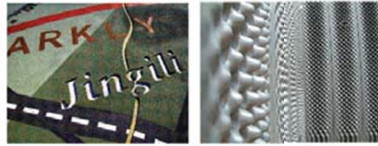

Figure 63: [below] Interior Theatre [ARM, 2012]



Figure 64: Garden of Australian Dreams: courtyard at the heart of the facility [Author, 2003]



Figure 65: [above] Combination of components relating to *Gesamtkunstwerk* [ARM, 2012]

Images of the National Museum of Australia with references.



Figure 66: Expressive entrance route canopy known as 'The Uluru Axis' due to its alignment with the Uluru Rock national landmark [Author, 2003]

## [1] The National Museum of Australia - ARM Architects

### Concept

The design can be seen to thematically reflect *Gesamtkunstwerk* through its concept of 'knotted ropes' symbolically intertwining Australia's stories. As ARM Architects [2012:(online)] state: "We liked to think that the story of Australia was not one [story], but many tangled together. Not an authorized version but a puzzling confluence; not merely the resolution of difference but its wholehearted embrace."

The building symbolises the conceptual 'knot'; with threads extending into the landscape. The unconventional and unpredictable mixture of forms, angles, colours and textures aims to break the usual staid museum typology [ARM, 2012:(online)]. Such eccentric building form and arrangement caused much delight in the eighteen-year old author prior to commencement of formal architectural studies. 'An Architecture of Delight' thus contributed to the author's normative position.

Figure 67: Interior Entrance Foyer. The form is derived from the shape of a knot; with the built form occupying the negative space [Author, 2003]

2.1 Introduction 2.2 Design Generators 2.3 Conceptual Approach  
2.4 Design Development 2.5 Place of Exchange Typology: The Precedence of a Market  
2.6 Design Development Continued

## 02 design development

## 2.1 Introduction

The following chapter documents the investigation's design development. As critique was gained over the course of the investigation, not only did the design change, but the programme and its resultant components as well. One such major programmatic change resulted in the originally proposed 'Creative Exploratorium' changing to a 'Creativity Centre' in order to reflect more of the inherent artistry currently in the Newtown Cultural Precinct and to provide a place for such important existing, but primarily overlooked, regional creative practices.

As the design progressed, further precedent studies were undertaken, as well as conceptual development and theoretical exploration further impacting the design translation. A profound, meandering journey of design and self-discovery was experienced, with extreme design propositions being explored before a more appropriate design was realised.

## 2.2 Design Generators 2.3 Conceptual Approach

### Summary

The design generators, as previously discussed in more detail in Chapter 002-3.9 *Architectural Response*, are seen to combine hierarchically to influence design decisions:

1. The *programmatic needs* and *architectural aims*: which include incorporating art into the everyday conscious of users and commuters; and the design of a welcoming, stimulating and functional public arts building.
2. The *urban investigation*: which relates to the site conditions; principles of sustainability; current and proposed site characteristics; historic and cultural relevance of the area; existing buildings and functions; and the design's response to the proposed framework (refer to page 65).
3. *Gesamtkunstwerk* theory (refer to page 85).
4. Analysed *precedents*.
5. The *psychological* effects of spaces are also kept in mind in terms of volume and light, enclosure and openness.

### Outline

The design concept profoundly influenced the design's development. The concept of 'Fragmented Unity' is implemented in terms of the building components being seen to be simultaneously self-referential to their particular function; while articulating their combined unity and relevance in the greater workings in the family of buildings Refer to *Figure 60* on page 112 for the parti-diagram.

#### Fragmented Unity

'the whole is greater than the sum of its parts'

*parts working together for a common goal*

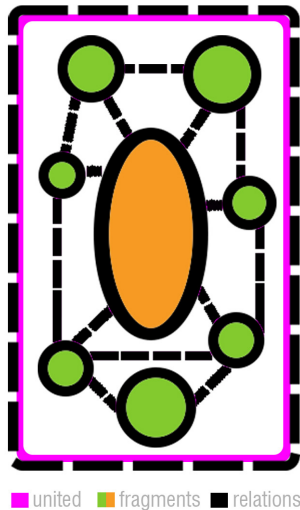

Figure 69: Parti-diagram illustrating the essence of the design concept through fragments relating to one another to create a united offering [Author, 2012]

### Conceptual Intentions

The 'Fragmented Unity' concept therefore leads to the exploration of clustered organisations. Clustered organisations predominantly display the uniting of different components through a common aspect: such as an architectural style, or around a spatial void as in the previously examined precedent of The National Museum of Australia's Garden of Dreams courtyard - *Figure 60* on page 112.

Francis Ching [2007:222] analyses such clustered organisations to rely on physical closeness; sharing a common orientation; or formal aspects such as the use of an axis or symmetry to denote unity in the arrangement of different sized or functionally-diverse components.

Ching highlights the advantage of such organisations: being in their ability to accommodate additions or subtracts more easily than monolithic designs with rigid structures. Architectural devices such as movement routes or entry points are often seen to organise clustered elements.

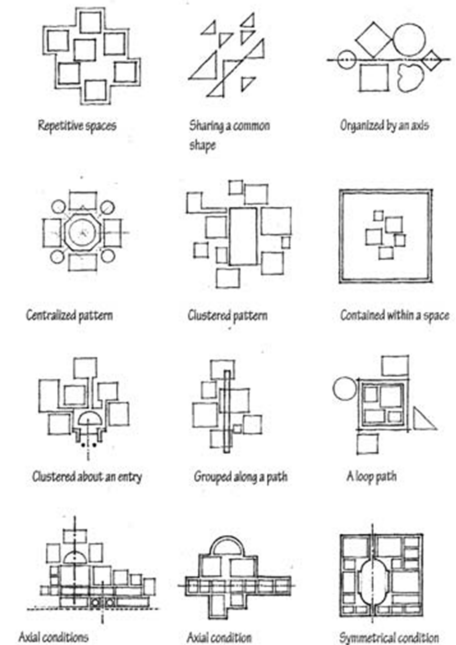
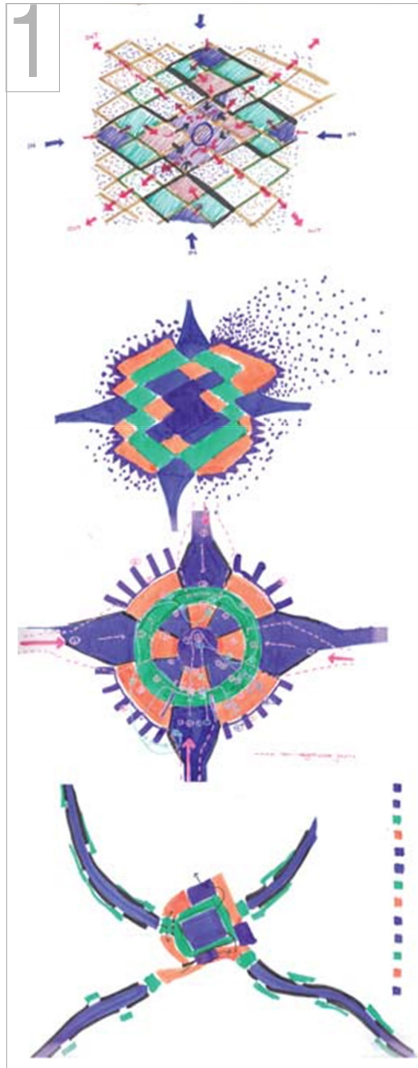

Figure 68: Different layouts of clustered organisations [Ching, 2007]



## 2.4 Design Development

### Design Stages

[1] Exploratorium commencement through theorisation

Generative Psychological Stance:  
Kolb's Modes of Learning  
Movement | Route

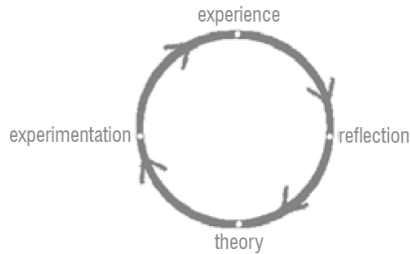
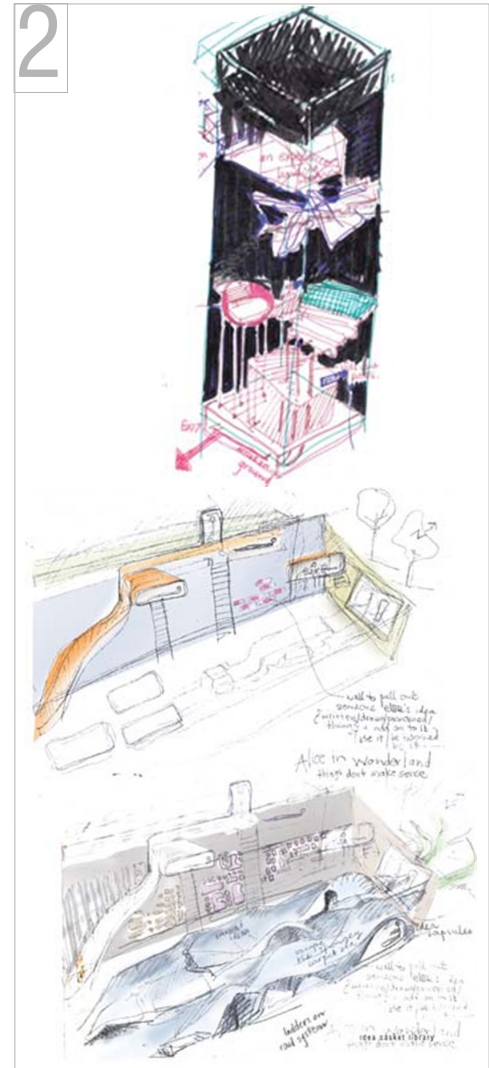

Figure 70: Diagram relating the stages of Kolb's Modes of Learning [Author, 2012]

The Imagination Station design proceeded from its urban response through generating appropriate movement routes through the use of Kolb's 'Methods of Learning' theoretical psychological principles. The different activity spaces reflect one of the four learning methods of: experiencing, experimenting with, reflecting on or theorising creativity. Spaces are ordered according to this cyclical sequence when entering and departing the building on route to the main exhibition hall. The different activity spaces therefore promote their different activity agendas. For example, zones encouraging contemplation are distinguished from spaces facilitating experimentation.



# 3

## [2] Adding Imagination

Spaces and routes were explored to generate imagination in the user. A tower system [2i] with hanging containers housing curatorial ‘themed rooms’ was designed to relate to the existing lone early Twentieth Century cooling tower. The Idea Library [2ii] was seen to contain caskets in removable building components that could be relocated around the city. Users would fill the caskets with objects and written words, before the mobile components would be substituted back into the library’s structure. A creative inspiration cross-city dialogue would thus be established to keep the facility fresh and relevant.

## [3] Blank canvas for functional programmatic requirements

Through exploration, it was decided that the building required ‘blank canvas’ spaces for its functional, creative activities. The users and the programme were thus seen to articulate the building’s creativity; as opposed to the building demanding attention through formalistic means. This development was also steered by re-looking at the sensitive historic nature of the urban context and therefore designing a building that respected and responded more tacitly to such heritage. The program elaborated by including sunken studio spaces for visiting artists.



External Pole Garden

for appropriation  
by invited artists



Figure 71: Central Pole Garden for appropriation  
[Author, 2012]

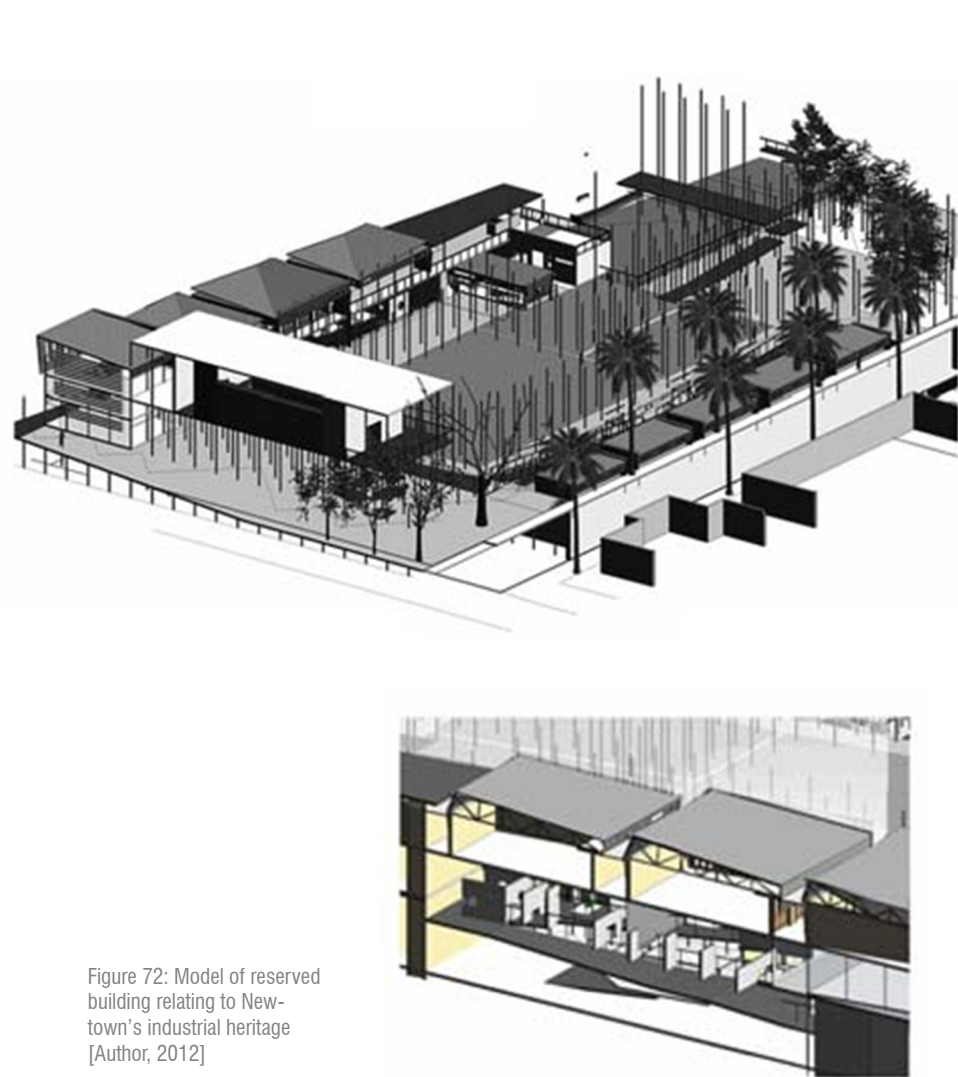
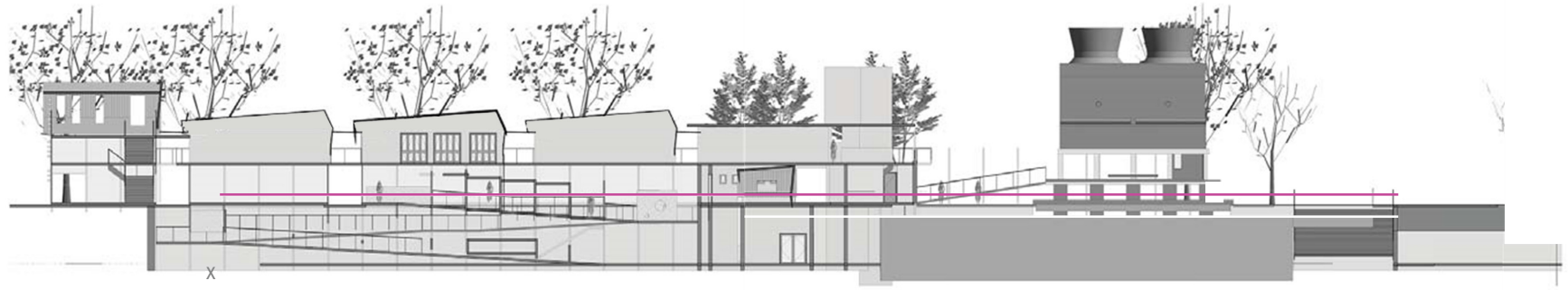

Figure 72: Model of reserved building relating to Newtown's industrial heritage [Author, 2012]



1 N-S through IS ramp



2 N-S through Sunken Studios



3 Section FF \_ Sunken Studios East Elevations





## 2.5 Place of Exchange Typology: The Precedence of a Market

### Chapter Outline

Developing the design lead to investigating the centre as a place of exchange and as a community gathering hub to foster creative identity. The market typology aptly fits such requirements. The following chapter first explores the elements constituting the market typology [A]; then discusses the exploration's relevance to the dissertation [B].

### [A] Markets

#### What defines a Market?

Catherine Slessor [2005:52] states: "Markets are an important neighbourhood focus for both economic and social exchange and their presence helps to cultivate a strong sense of place and community." Markets are more profound than simply places of exchange or venues offering goods for sale. They are community places of interaction displaying 'street level' culture. Often, markets can be seen to be a microcosm of the particular city itself: bringing together and enhancing the relations and expressions of direct and distant communities.

### The Market as a Place of Exchange

#### 1. Time-scale relation

The notion of exchange can be seen to originate from the very essence of homosapien interaction: a primitive need to trade for what one is lacking for individual or situational betterment. Historically, souks acted as market spaces, provided neutral ground on which individuals from different tribes could meet [Cochrane, 2005:42]. This is still seen through tourists visiting local markets to experience the raw essence and culture of the particular region.

Contemporary places of exchange are invaluable in their offering 'blank canvasses' to permit people and ideas to expand and develop. Such places provide spaces that allow people to feel at ease: unhindered, in order to appropriate the opportunities presented.

Diana Cochrane [2005:42] states: "We can monitor the heart rate of the contemporary city through the spontaneous activity of its markets." Such is due to markets being

formed from a myriad of layers all amalgamating into a delectable melting-pot of cultural experience. There are layers of activity; layers of goods and services - in terms of commodities, offerings and ideas; and layered relations creating and adding to frameworks within the city itself [Cochrane, 2005:42-43].

#### 2. The Appeal of Markets

While markets often support the most basic human need of supplying food, they are seen to hold an allure over generic retail venues epitomised by supermarkets and shopping malls. The perceived haphazardness and 'raw, elemental' quality of many markets is more welcoming than the harshly lit, monotonous, static structure of generic retail outlets. Markets speak of *genius-loci*, while slick and shiny stereotypical retail outlets are predominantly repetitive; and independent of reflecting regionalism or even nationalism [Cochrane, 2005:42].

The history of the sea-side town of Knysna along South Africa's Garden Route provides a fitting example. In the mid-1990's, it



encompassed a quaint town atmosphere with a Rastafarian-market hidden under tarpaulins, which in turn were sheltered by large, mature oak trees. There was a mystery to the market as the passage through it was winding and full of intrigue, as it was unknown what would appear around the next bend. A ‘cave-of-wonders’ was waiting to be explored.

Fifteen years later, after a surge of development, with Knysna becoming a premier holiday and retirement destination, the oak trees have been felled and the informal market turned into a solid brick structure housing official retail shops. Three malls line the once quaint street. The charm of genius-loci that once was so apparent has been lost. The generic shopping malls could be located in Johannesburg or Jansenville; as they hold no ties with their regionality. The market’s regional retail offerings have been overridden by the same generic products available nationwide. Such an example begins to illustrate the proceeding discussion of the aspects that make markets so appealing.

Figure 73: Porter’s Market, Tokai Forest, Cape Town, South Africa: conveys a holistic market atmosphere [Author, 2010]

#### Market Appeal #1: Sensual Stimulus

Markets, humble to sophisticatedly designed, are often so rewarding as they excite the senses – through their smells, sights, noises, tastes and textures. The wares on display; the characters selling such goods; the bustling crowds; the feeling of cobbled marketways or woodchips underfoot all add to the sensual delight [Slessor,2005:52].

#### Market Appeal #2: Raw, Elemental Feeling

Market structures are often temporary or brutally simplistic in structure due to their general nature as intermittently-staged occurrences. It is therefore logical that such accommodating structures are commonly simplistic and more functional than aesthetically costly. Such spaces become very elemental in their minimalistic aesthetic; which adds to the pleasurable nature of the market, especially in harsh urban environments. Users feel in touch with their ‘earthy roots’; connected to nature, the rough and real. A feeling of truth and honesty pervades such holistic markets.

Cochrane [2005:42] describes how the goods are ‘naked’: often with far less interference between product and consumer than retail offerings. This immediacy and experience of truthfulness enhances the grounded, tangible and satisfying nature of the market experience.

Goods are also often unique and produced in limited quantities as opposed to blandly repetitive supermarket products. Many goods display a sense of pride in being hand-made; and are generally sold by the producer. Such factors add richness and personal anecdotes to the products, coupled with the sensual market atmosphere that is so blatantly missing from generic retail outlets. The market stalls often decoratively reflect the goods and personality types of the sellers: which adds changing variety and interest in the market. The fact that most market sellers have to set up their stalls for every occasion makes the finer details and display arrangements more likely to differ compared to retail stores.

---

### Market Appeal #3: Human Interaction

Markets are commercial spaces designed towards people in comparison to supermarkets being designed for servicing ease. Markets are places of action with trading, talking and bustle. The intimacy of personalised human interaction and social stimulus is another appeal of the market.

Such intimacy and palpable delight is becoming harder to experience in retail stores and everyday life due to a greater degree of investment in the technological world. Goods and idea exchange now predominate over the internet: in solitude, without human banter or interaction [Cochrane, 2005:42].

### Market Appeal #4: Unexpected Encounters

Markets often hold surprises due to their nature of adaptability and change. Every occasion introduces new clientele mixed with the usual customers: whose actions and interactions will always be unique, even if somewhat manipulatable. The market speaks of diversity in its offerings and users; vitality in its interactions. The basic market structure

gives a platform for use with the rest of the happenings being left up to human interaction, endeavour and chance.

### Market Appeal #5: Thrill of Bargain Hunting

A further appeal of the market is held by the excitement induced by potentially finding an unexpected bargain [Cochrane, 2005:42]. There is an instinctual sense of familiarity to such actions, as a prehistoric hunter, “you impulsively know how to act, and the possibility of exploring, finding new bargains is insatiable” [Cochrane, 2005:42].

### Subsidiary Market Appeal: In Vogue Social Image

Newly implemented markets have been gaining popularity in gentrified areas where the glamorous trendsetters like to be noticed.



---

### 3. Components of a Perfect Market Stew

The market typology is comprised of a central set of components:

#### 3.1. Framework: The Cooking Vessel

Markets often provide a minimalistic skeleton framework which facilitates market stalls; delineates movement routes and key focus areas for interactions; as well as structuring the market's relation to services, parking and the surrounding urban fabric. Design explorations can include the degree of framework required for a meaningful intervention; and the preferred skeleton dimensions and materiality. Variations in design answers would depend on the type of market; its area; social standing and the surrounding urban environment.

#### 3.2. Goods: The Vegetables

Market stalls are orchestrated by a management team for their variety of wares contributing to a well-rounded totalising market offering and experience. Certain markets are themed according to their nature.

#### 3.3. Sellers: The Meat

The sellers provide the meaty titbits to the market stew, as with their trade of personal marketing skills and tactics used to promote their wares. Design explorations relating to the sellers include ease of assembling and dismantling their displays.

#### 3.4. People: The Broth

It is important to assess and orchestrate the target buyers the market wishes to attract and maintain. The target buyers will be governed by the urban location; type of wares for sale; types of sellers; and the market's image through advertising and market design.

#### 3.5. Movement: The Stirring Spoon

Movement routes are largely demarcated and governed by the positioning of the stalls, with allowance for certain chance encounters and appropriation.

#### 3.6. Systems Governing the Market: The Hand Stirring the Spoon

Although markets often seem haphazard and informally arranged, Diana Cochrane

[2005:42] states how they are formed around intricate, often unseen organisational schemes.

#### 3.7. Social Spaces: The Heat

Movement routes facilitate circulation as well as forced and chance encounters; while specific areas, stalls and intersections are distinctly designed to be larger in order to facilitate socialising and additional programmatic elements - such as food consumption [Cochrane, 2005:43].

#### 3.8. Micro-spaces, Nooks and Crannies: The Spices

Cochrane [2005:42] describes markets as being comprised of 'micro spaces' contributing to a greater whole. She elaborates [2005:43]: "Places of exchange should have nooks and crannies, playful and surprising with human-scale places to explore and hide in. Places from which you can surreptitiously view the action". By this means, certain markets can be seen as a reflection of *Gesamtkunstwerk*'s 'total artworks' through fragments creating a greater whole.



#### 4. Characteristics of a Market:

##### 4.1. Public Space

Markets are generally public spaces, accessible to all interested people.

##### 4.2. Informality

Market spaces are seen as informal entities through their openness to change and evolution [Cochrane, 2005:42].

##### 4.3. Openness

Market spaces physically embody a feeling of openness due to their minimalistic structural enclosure and informality [although the less enclosed structures can be functionally problematic in inclement weather]. Market spaces can be conceptually read as 'open-minded' in their ability to change. Cochrane [2005:43] states that well-suited places of exchange, "are generous not exploitative, open to reinvention and new uses."

##### 4.4. Unforced

With the qualities of informality and openness, associations in markets are less forced than conventional retail centres, and left more to users' interpretations [Cochrane, 2005:42].

##### 4.5. Events of the street

Markets are described as 'events of the street' [Cochrane, 2005:42]; with a dualism existing between street culture influencing market life and visa versa.

##### 4.6. Complexity to promote liveliness

Cochrane [2005:43] states the importance of markets being multifaceted fabrics: "Places of exchange should be complex places where many layers of activity and space coincide, ensuring varied and lively transformations at different times of hour, day or week."

---

#### 4.7. Unified Eclecticism

Markets are eclectic in their nature of housing a variety of goods and experiences, while being united through a common theme, artistry or physical structure. Markets, therefore, often conceptually fall into the notion of *Gesamtkunstwerk*.

#### 4.8. Appropriate Scale Relations

Cochrane [2005:43] describes how markets are specially designed for human-scale activities; with appropriate scale changes being made according to the product and programmatic requirements.

#### 4.9. Adaptability and Evolution

The beauty of the market typology lies in its informality that allows its program to change and adapt to new lifestyle needs. This adaptation keeps it relevant to the urban context and user: sustaining the market in its own right.

Users are seen to hold greater power over evolving the market to suite their changing needs. The market derivative is therefore more personally satisfying to the direct community than a generic retail chain store [Cochrane, 2005:42].

As Cochrane [2005:42-3] states, “The continual evolution of the stalls ensures that each time the ‘market’ is visited, the experience is different. People feel comfortable in places that have a sense of evolution and ‘specificity’.”

#### 4.10. Identity in the city

Markets provide regionally imaginative and stimulating city cores through creating a melting pot of ideas, people, goods and programmes. Markets often become points of urban acupuncture with abandoned spaces being taken over and energised through adaptive re-use. The identity of a market often encapsulates and spurs on the identity of the area.

Cochrane [2005:43] states: “Great places of exchange invigorate the city because they become fully incorporated into its fabric, its patterns of use and its identity. They are seamlessly connected to all networks of information that have become essential to our daily routines... They are not just buildings but pieces of the city.”



Location Plan

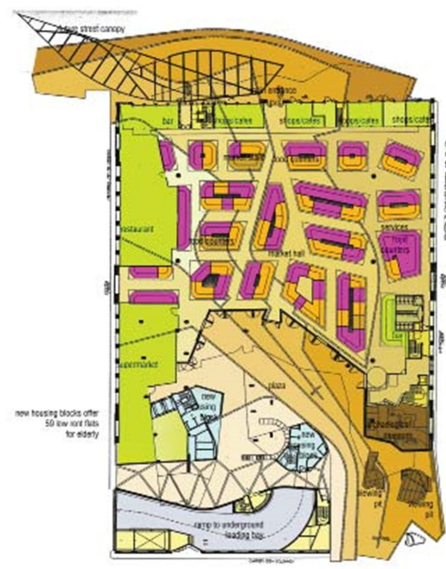

Plan - Ground Floor

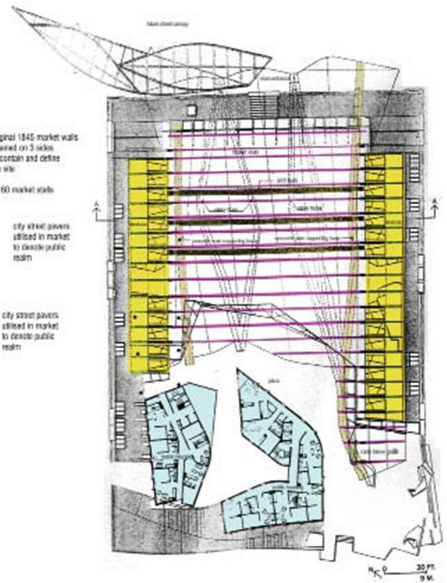

Plan - Level 2



Urban context

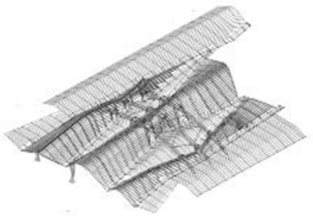

Roof structure

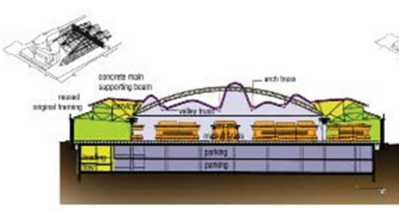

Section AA



Longitudinal Section

Figure 74: Original Cohn [2006] graphics of the Santa Caterina Market manipulated by Author [2012]

## 5. The Market Typology Precedents

### 1. International Precedents: Santa Caterina Market, Barcelona, Spain

#### Analysis

#### *Background: History, Context and Siting*

The Santa Caterina Market is located in Barcelona's Gothic Quarter, three city blocks from Barcelona Cathedral - the city's main medieval cathedral. The original Neoclassical market building dates back to the Nineteenth Century: being Barcelona's oldest covered market. The surrounding area, a low socio-economic flatland, is close to Barcelona's city centre. Due to the market's dilapidated form, organisational disarray, physical stench and commercial and civic demise, redevelopment proposals were put forward in 1997.

#### *Area and Market Revitalisation*

The scheme proposed by architects Enric Miralles and Benedetta Tagliabue of EMBT focused on 'bottom up' regeneration for the rundown urban context and market building.

EMBT [in Cohn, 2006:98] sought to rework the market to suite contemporary lifestyle requirements. The revitalised programme includes sixty market stalls; small shops; cafes; a supermarket; a restaurant; community services; underground parking; a pneumatic garbage-collection system and archaeological viewing spaces for remains of the medieval Convent of Santa Caterina [Slessor,2005:46].

The primary architectural element uniting the revitalised scheme, is seen in the new tiled roof: "a flying carpet of brilliant colors [sic] and agitated forms" [Cohn, 2006:98]. The roof's artistic expression relates to the Catalan tradition of mosaic ornament, while creating a contemporary advertisement for the market [Slessor,2005:46].

The suggestion of an urban jungle is implied through tree-like vertical metal supports at the roof ends, as well as the vaults contributing to the irregular lighting, colours, textures and forms [Cohn,2006:105]. The warmth of the cedar timber plays against the coldness expressed by the metal-supports.

#### *Commentary on the Market's Revitalisation*

The revitalisation of the Santa Caterina market is commonly viewed as successful, with Cohn [2006:98] stating that it has been able to "bring life and light into one of the worst slums of Barcelona's Gothic Quarter." As importantly, the market has managed to foster and articulate the importance of community in an increasingly individualistic era [Slessor, 2005:44].

Appreciation for the need for and value of considered human interaction in contemporary technologically-obsessed society is also articulated. As Slessor [2005:52] states: "Most encouragingly, its [the Santa Caterina market's] rebirth has proved that the notion of a food market, which thrives on the slow, patient dynamic of personal contact and service (this cut of meat, that crab, those aubergines) can be successfully reinvented for the hyperdriven, modern world." Slessor [2005:46] continues by encouragingly recounting the sensual delights offered by markets: "Daily, it [the Santa Caterina market] beckons legions of locals equipped with stur-



dy shopping trolleys into its soaring vaults, filled with gleaming stalls laden with a mind-boggling range of comestibles. Vats of olives, rows of pungent cheeses, dangling hams, mounds of shellfish, regiments of eggs; here are feasts for all the senses, from the vegetable to the visceral – chickens with heads on, tripe, pigs' trotters, octopus – food in its wild, raw state that exhilaratingly defies supermarket sanitisation.”

*Teaching:* The sensual excitement embodied by this description should be able to be applied to the programmatic accommodation of The Imagination Station even though the 'exchange' is of a different nature and the building is to form a functional backdrop.

#### *Urban Revitalisation*

It is important to note that the urban revitalisation has been as successful as the market renewal itself [Cohn 2006:105], which is a lesson applicable in the culturally historic and formerly blighted Newtown Precinct.

#### Teachings

The Santa Caterina market teaches:

1. Selectively editing history.
2. Approach to working in a richly sedimented cultural-historic area.
3. Good urban design is a phased process with gradual results summing up to success.
4. Market offerings to relate to contemporary lifestyle needs and to further benefit area user's needs - even if not a commonly held need in the community's perception.
5. As with the Victoria Street Market's programme: having a mix of offerings; as well as anchor tenants and individual stores.
6. The open external public plaza balances the conglomeration of mixed smaller store components internally.
7. Embody primary architectural statement or element [roof in the precedent's case].
8. Aesthetic structural expression – as with *techne*: relating to the combination of aesthetics and technology.
9. Reinterpret regional customs/symbols for contemporary relevance and artistic expression.
10. Structural layering for richness and

#### *genius loci.*

11. Selectively reuse old and sensitively relate it to the new.
12. Personal service contact is appreciated in the contemporary world.
13. The sensual delight of markets is devoured.

## 2. 'La Pescheria': Treviso Fish Market, Italy

### Analysis

The Treviso Fish Market has been operational on an island located in the Cagnan river since 1841. Subtle improvements were designed by architect Toni Follina in recent years.

Improvements included the re-design of the market shelters; repaving the walkway and construction of a central lightweight glass roof. Live fish are kept in baskets in the river; which are accessed by descending stairs positioned at regular intervals along the island bank. Clean water is derived from a central fountain, which also holds ceremonial connotations. Two bridges permit continual thoroughfare on each end of the island's longitudinal axis. The grassy banks are used for recreational means after-hours as an urban park [Blundell Jones, 2004:98]. The river's perimeter is contained by historic buildings,

which enhances the pertinence of the functional 'island of delight' fully conveying complete *genius-loci*.

### Teachings

The Treviso Fish Market teaches:

1. The importance of holistic development, with all aspects functioning as a whole.
2. The effective utilisation of opportunities provided by surroundings.
3. Delight found in *genius-loci*.
4. Dual-functioning spaces.
5. Tacit improvements to cultural-heritage. Renovated paving can often add more value than architectural demolition.
6. Massing around a low-lying intervention heightens the intervention's prominence.

Figure 75: Historic Depictions of The Treviso Fish Market [top left]; along with its contemporary atmosphere and renewed structures [Blundell Jones, 2004; Treviso Information, 2012]

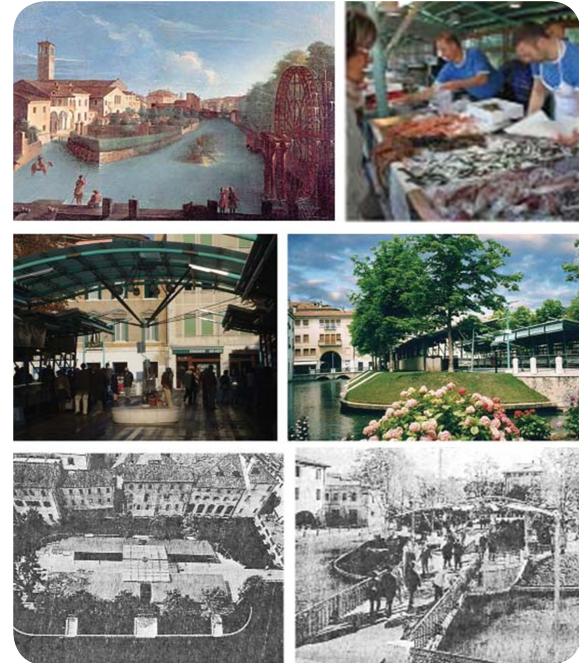

### 3. National Precedent: Victoria Street Market, Durban, South Africa

#### Analysis

Durban's Victoria Street Market began as an Indian Market in 1910. It acted as a lively tourist attraction on top of its trade functions of selling herbs; spices; curries; incense; meat; fish; fresh produce and saris; as well as wooden, metal and ivory ornaments [unstated, 1990:14].

In 1937, the building was destroyed by a fire. Fifty years later, the Market's 9,318 square-metre site was reconceptualised by JD Maresch Architects. The new building was designed as a market or bazaar, as opposed to that of a shopping centre. The design integrated fifteen to fifty square metre dry good stalls; thirty-four wet good stalls; fifty-five formal retail spaces and an internal atrium and external piazza for informal trade in the three level structure [unstated, 1990:16].

Informal trade spaces were designed to be adaptable. Indian market-culture was echoed through the layout; movement routes; colour-palette; paving and architectural features such as the arches, pavilions, towers and domes [unstated, 1990:15].

"In the design of the market, the architects have endeavoured to contribute to a sense of discovery and adventure and the stall layout is crossed by many routes varying in width. Rigid linear placement of the stalls is minimised by irregular overlapping of retail space into the passageways and open areas. Every opportunity has been made to provide an improved quality of life for the people who trade into the passageways and open areas" [unstated, 1990:17].

#### Teaching

The Victoria Street Market teaches:

1. The tourist-attraction ability of places of exchange.
2. The relation of goods and services to the seller's identity; as well as the area's needs creating an identity for the establishment in the city.
3. Articulation of cultural heritage in the design.
4. The variety of programmes accommodated to create a complex, layered fabric.
5. Fixed stalls – components – *and* informal, changeable components creating a stronger offering than a singular typology.
6. Creating narratives in movement routes – to articulate a 'sense of discovery' and 'adventure'. Design complexity and difference in the circulation routes, such that variety and intrigue are encompassed in each visit.

Figure 76: The sensual feast at the weekly Durban Market [Author, 2012]



## [B] The Imagination Station as a Market:

Relevant market typology research to be imbued in the dissertation:

### Newtown Area

The Newtown Electric Power Station Heritage Precinct and Imagination Station site should be seen as a *microcosm* [Cochrane 2005:43] of the creatively dispersed greater Johannesburg city. This can be achieved through applying the principles of markets, previously outlined in *Chapter 003: Section 2.5* to the proposed architectural design.

### Historical Character of Newtown

As Leonard Rosenberg [2008:28] describes the Warwick Triangle area in Durban as 'a treasure chest', so too can Newtown, Johannesburg, be described as an area holding vast historical memories and present enticements. The Santa Caterina Market shows the importance of selectively editing such historical data.

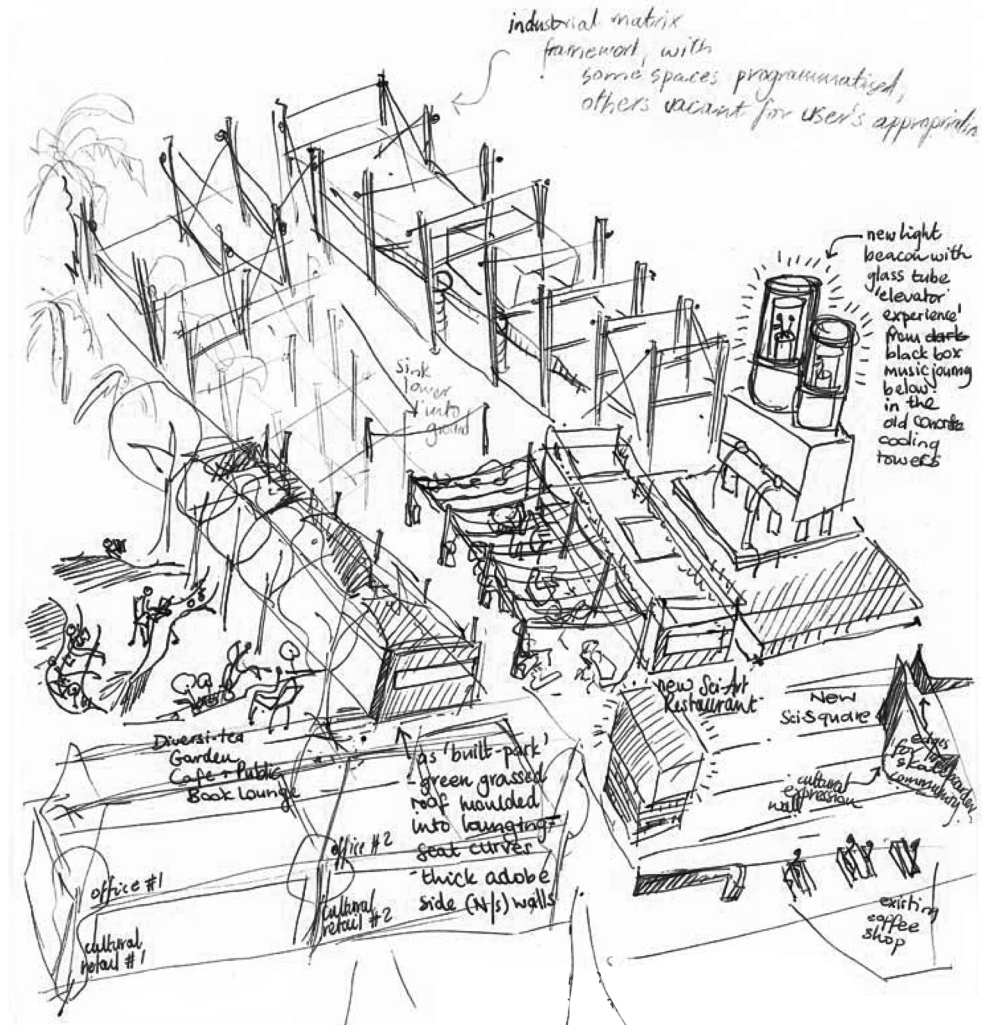

Figure 77: Sketch of The Imagination Station according to the Market typology exploration [Author, 2012]

## The Imagination Station Site

As with the generative points from analysing the market programmes and structures, The Imagination Station aims to:

1. Create an atmosphere of excitement and intrigue for users to explore and insatiably 'find new or unique products or bargains' [Cochrane, 2005:42]
2. Engage the user's senses
3. Represent genius loci and add 'soul' to the area [Rosenberg, 2008:30]
4. Be a social and area melting pot – foster social space. With proposals for increased housing to the North of the Newtown Precinct, as well as the new Newtown Junction shopping complex on the former 100 year old Potato Shed site, it is seen to be important to make a community neighbourhood for Newtown's newly developing residential sector.
5. Foster participant and user appropriation, with a structure that acts as a frame for present and future activities. Cochrane [2005:42] aptly asks: "How can we make buildings for the exchange of services, goods and ideas that have the energy, elasticity, excitement and

lightness of the market? Is it possible in an era of increased security to produce buildings that are frameworks or networks, that do not have ends or 'edges' thereby enabling infinite possibilities, choices, spontaneity and meaningful accessibility?" This question is further explored in the continuation of the design development...

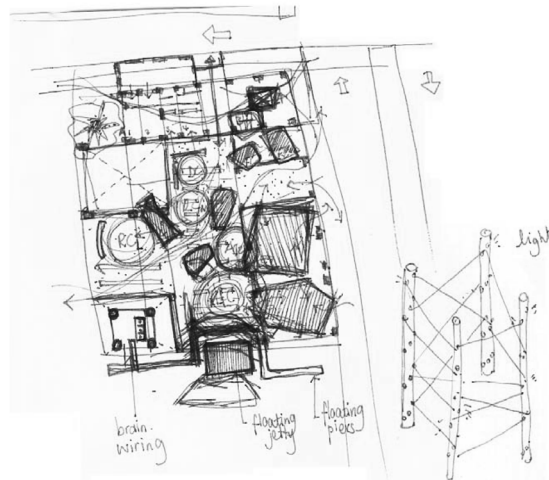

Figure 79: Sketch of Imagination Station Ground Floor [Author, 2012]



Figure 78: Sketch model development [Author, 2012]

## 2.6 Design Development Continued...

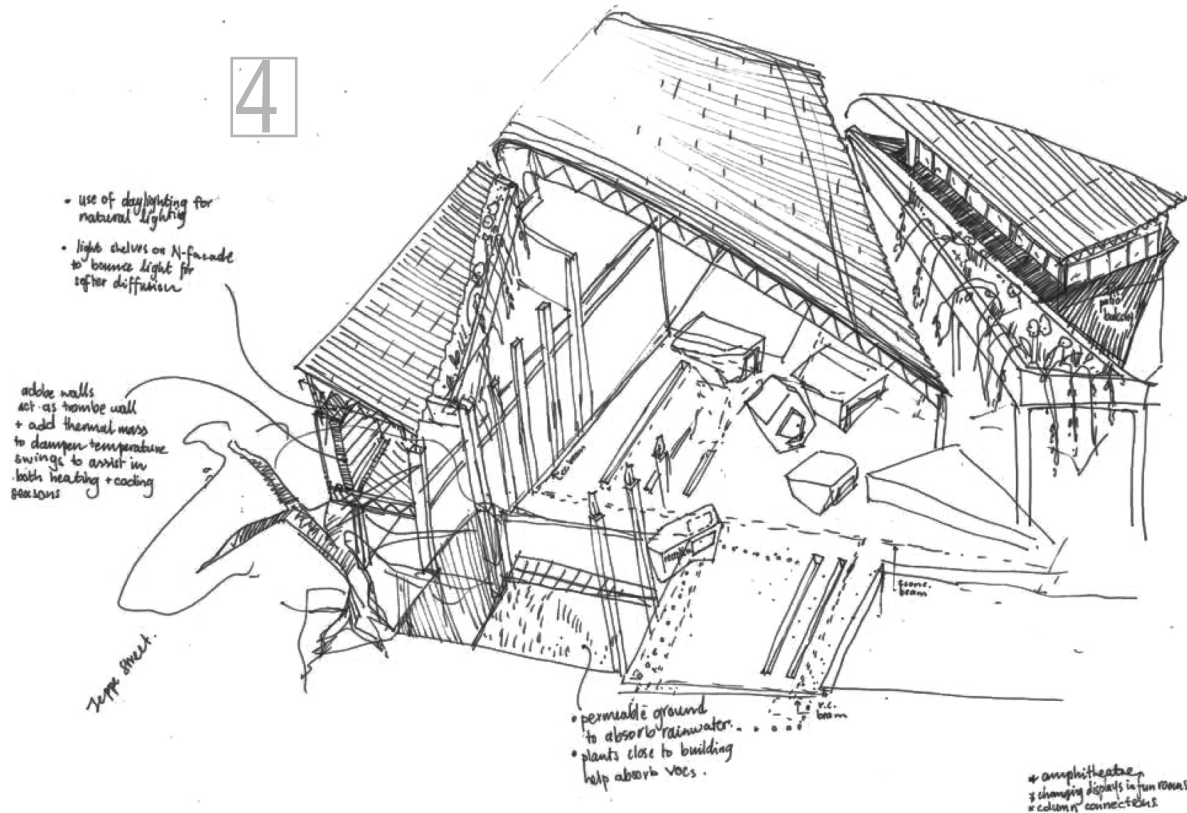
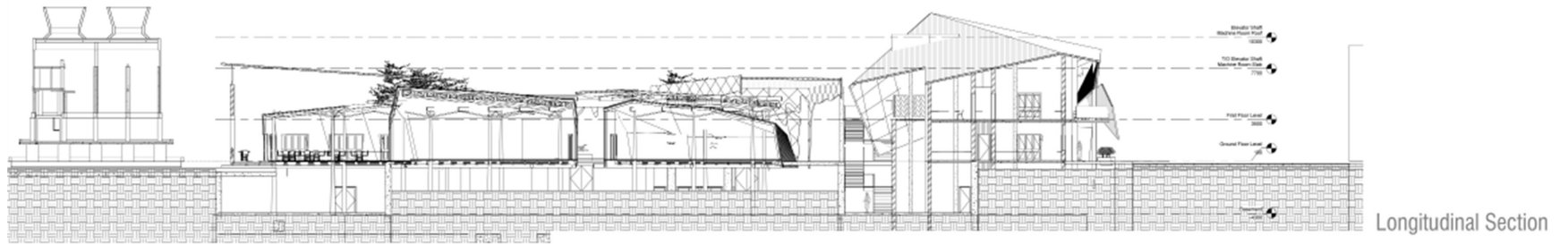

Figure 80: Sketch of Design Journey Evolution [Author, 2012]

With impetus from the explored market precedents and principles, the design responded through a framework with more animated spacial forms differentiating between the differing natures of the programmatic activities.



Figure 81: Sketch model development: experimenting with facade and corner articulation [Author, 2012]



3 Section FF  
1:100

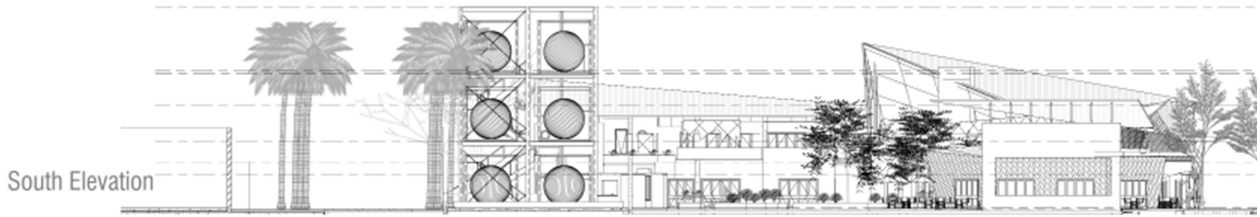

2 South Elevation  
1:100

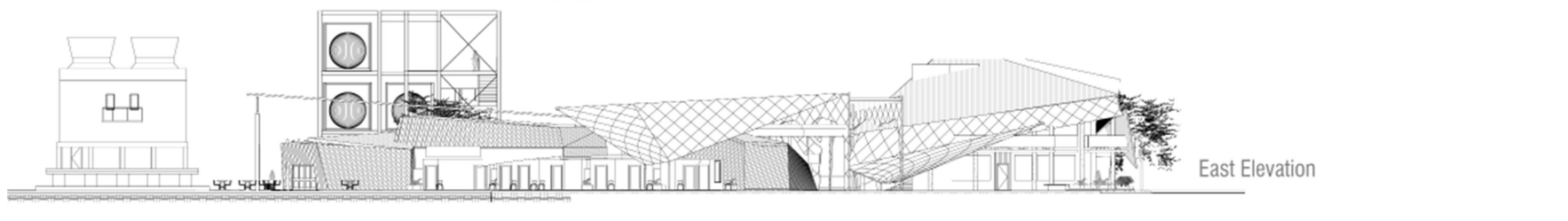

Figure 82: Drawings [Author, 2012]



3.1 Introduction 3.2 Urban Response 3.3 Zones  
3.4 Programmatic Articulation 3.5 Drawings

## 03 design outcome

## 3.1 Introduction

Once the functional spaces and general layout had been explored in the *design development* phase, the site influences were revisited. This exercise concluded with the building forms being tamed to be less self-expressive and act as a blank canvas to accommodate the functional program by more tacit means. The program becomes the dynamic element expressing creativity and not the architectural form itself. Material expression becomes a key element in the robust public building, as explored in the proceeding *Chapter 04, technical development*.

## 3.2 Urban Response

### Deriving the response

#### [1] Destination | Thoroughfare

The Imagination Station is a destination place for visitors with the direct purpose of coming to explore the creative facilities and environment in a similar fashion to Sci-Bono's purposeful visitors.

The Centre is also a place that permits and encourages public commuter through-flow in order to promote creativity in as many people as possible.

#### [2] Layers of Intimacy

Courtyards are used to demarcate degrees of intimacy in the Centre complex.

The *welcome court* pushes the built form to the North, in order to allow breathing space around the existing lone concrete cooling tower. This articulates the cooling tower's importance as a connection to Newtown's past functions. The welcome court also provides an open activity space for the proposed secondary commuter feeder route.

The *main courtyard* sectionally steps down in order to articulate its spatial difference for the instillation activities it accommodates, while creating a natural seating edge for users to gather under the peripheral trees.

#### [3] Routes feeding the Centre

The route linking The Market Theatre cluster to the North, past the site's western edge and down to Sci-Bono's entrance is defined as the *primary pedestrian access route* past the site. The program thus responds by keeping the site's western edge open and permeable so that visitors can see the Centre's happenings and be enticed to become involved.

Three open steel box frameworks suspending interactive activity spaces flank the walkway, as well as eating destinations and the Centre's main reception.

The site's *secondary route* runs in an East-Westerly direction from a newly proposed entry portal joining Turabine Hall's western facade to the NEPSHP, through the precinct until the precinct's western edge framed by restaurants and offices. As mentioned, the site incorporates this secondary route by integrating an open activity plaza.

### 1 | Place of :

a | Destination

+

b | Thoroughfare

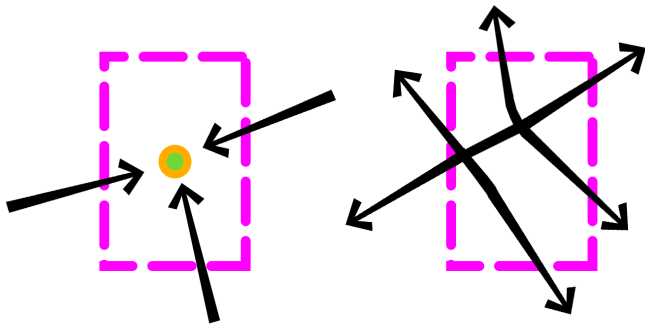

### 2 | Layers of Intimacy - Courtyards

a | Welcome Court

b | Inner Court

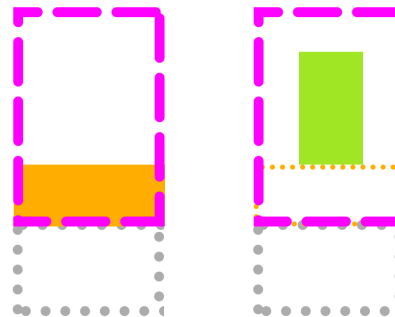

### 3 | Routes next to / through Site

a | Current (determined by fence)

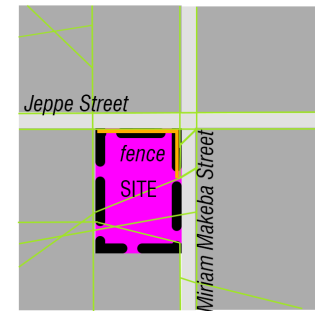

### 3 | Routes next to / through Site

#### b | Primary Route

North - South

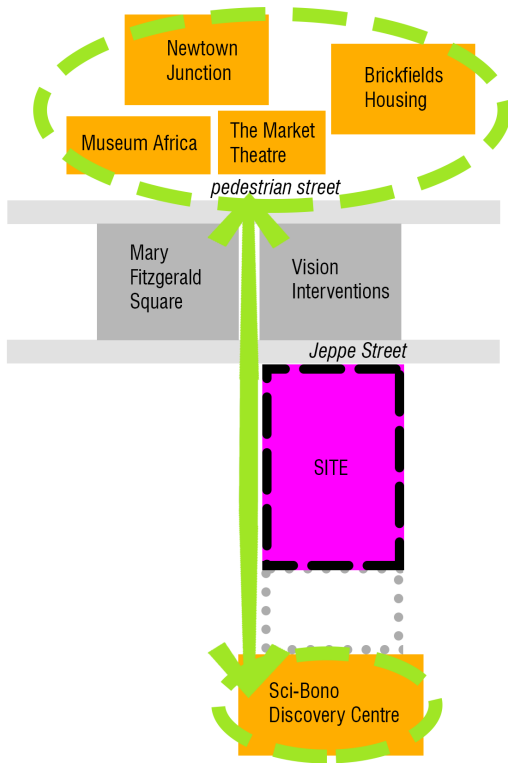

#### c | Secondary Route

East - West

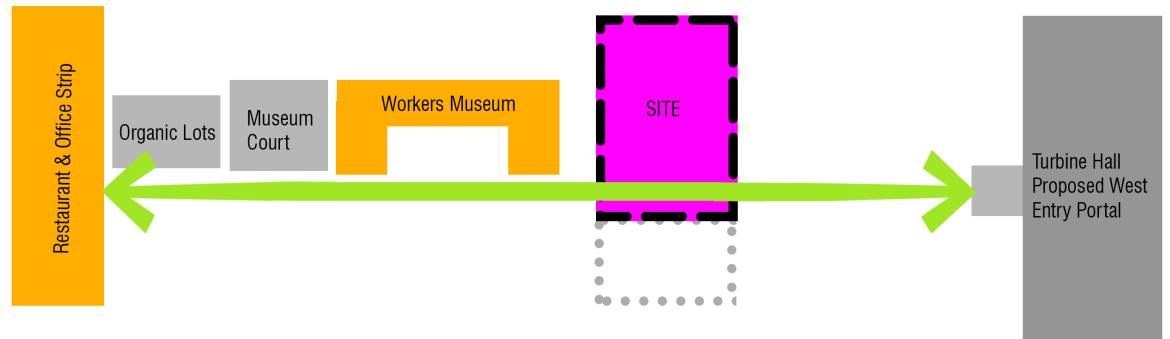

RESPONSE TO | Primary Route

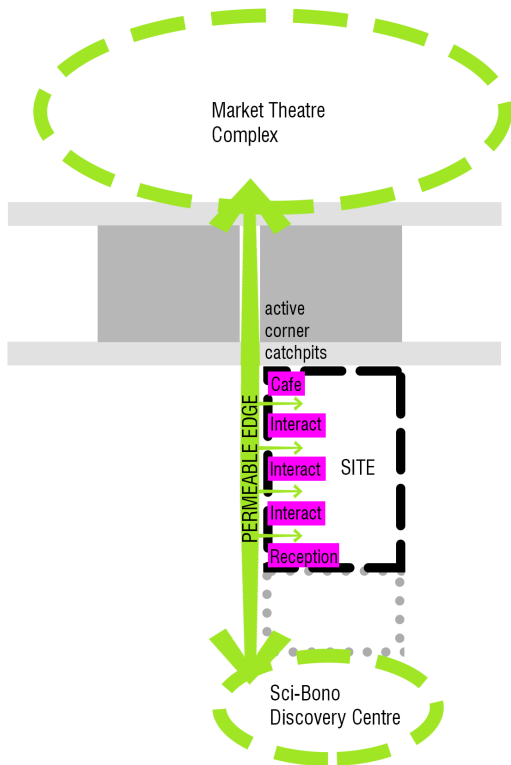

RESPONSE TO | Secondary Route

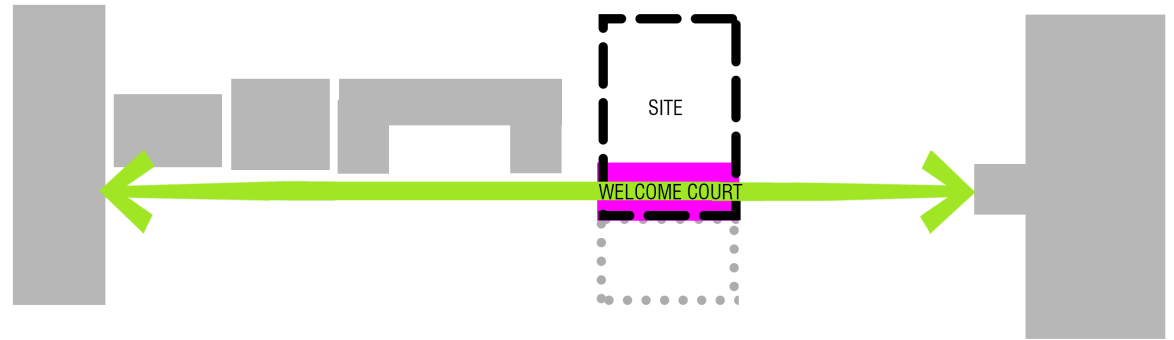

#### [4] Vehicular Routes

The differing natures of the two roads defining the corner site, bring about two very different responses.

Jeppe Street is a highly busy, one-way street running from the Inner City in the East, to Fordsburg in the West. Architectural responses

seek to counter Jeppe Street's noise and air pollution. The Centre's Northern facade is thus a 'closed facade' in terms of minimal thoroughfare and openable windows.

Due to the large number of pedestrians walking along Jeppe street, the architecture incorporates a colonnaded walkway to offer greater enclosure and threshold articulation

from the busy vehicular road. The walkway also articulates a further level of threshold protection and distancing for the main building activities from the road.

In contrast, the adjacent Miriam Makeba street imbues an astonishingly calm atmosphere. Miriam Makeba street is double lane on both sides of a traffic island supporting

#### 4 | Vehicular Routes

a | Jeppe Street (One-way from East to West)

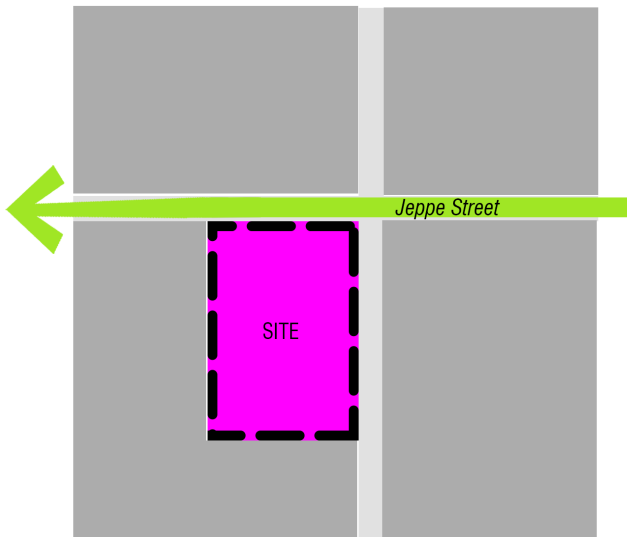

b | Miriam Makeba Street (North-South with central treed island)

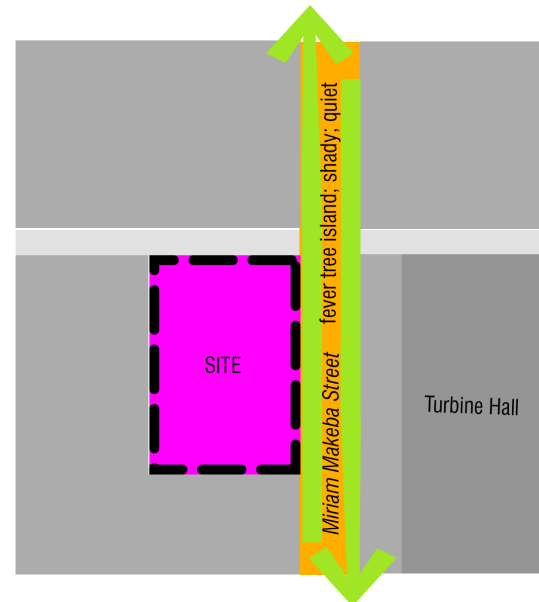

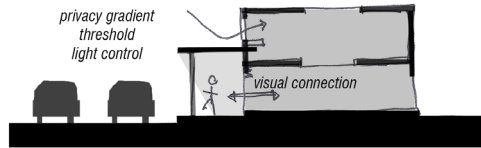

Jeppe Street - Colonnaded Walkway Response

mature fever trees providing dappled shade. Less traffic utilised this road, such that it emits a surprisingly subdued nature.

The architecture responds to Miriam Makeba street through visually opening up the buildings to its calm, shaded presence. The Ground Floor corner fully opens up when required - to encourage passers by to walk

through the Centre. Further down Miriam Makeba street, the Centre's Hall utilises large glazed doors to allow passers by and people waiting for transport to see the Hall activities and even further beyond into the central courtyard. The doors are designed with blinds between double glazed skin in order to close the hall visually when activities require darkness or a private venue.

a| RESPONSE:

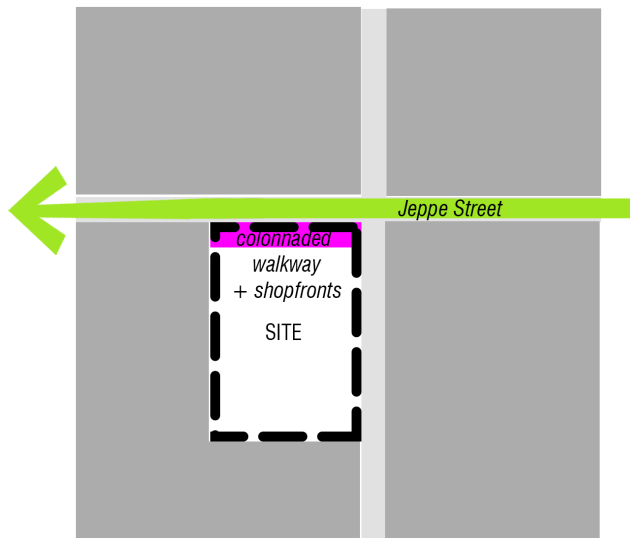

b| RESPONSE:

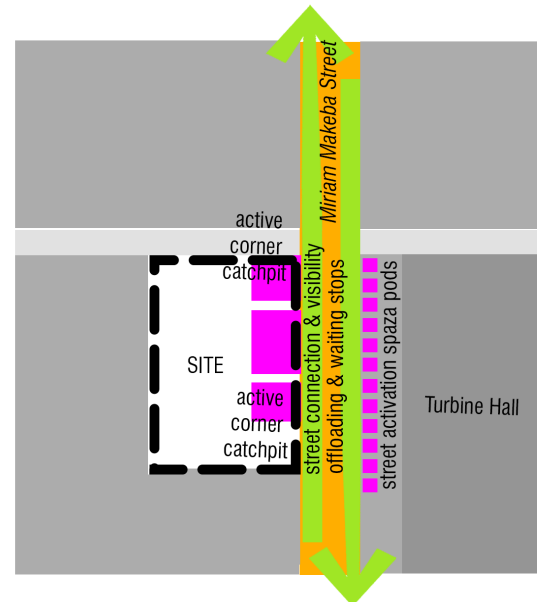

## [5] Museum Walkway

Tertiary site routes include a newly proposed 'Museum Walkway' to the south of the former workers buildings and north of the Worker's Museum. The line of the walkway is continued and articulated by The Imagination Station building mass to the North of the site. The walkway thus terminates in the foyer of the Imagination Station and the newly proposed Museum Court to the west.

## 5 | Museum Walk

a | RELATION: incorporate Museum Route continuation

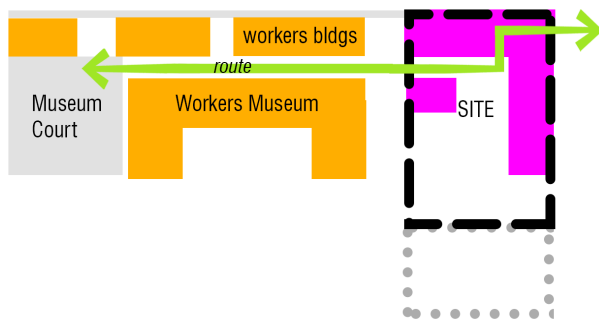

## [6] Positioning

The site's corners are seen as key elements to draw passers by into the Centre. The corners can be programmed to accommodate social and/or changing activities to make the corners stimulating and enticing. The architectural elements are to define the bounds of the site and thus compose the Centre as a work of *Gesamtkunstwerk* through the united whole being felt through edge definition. Simultaneously,

the corners are to appear inviting and open in order to encourage visitor participation.

### a | Corner Catchpits

The site's corners are thus used as cafe's for vibrant social space and receptions accommodating changing instillations to articulate the programme of the facility and orientate any new visitors to its changing activities.

### b | Receptions

The *primary reception* welcomes visitors arriving from the site's south-western edge of the Newtown Park, which is seen as the centre of the NEPSHP, Sci-Bono and Worker's Museum user routes. The north-eastern corner foyer acts as a *secondary reception* and orientation point.



## 6 | Positioning

a | CORNER CATCHPITS  
- to welcome, entice, invigorate & stimulate activity

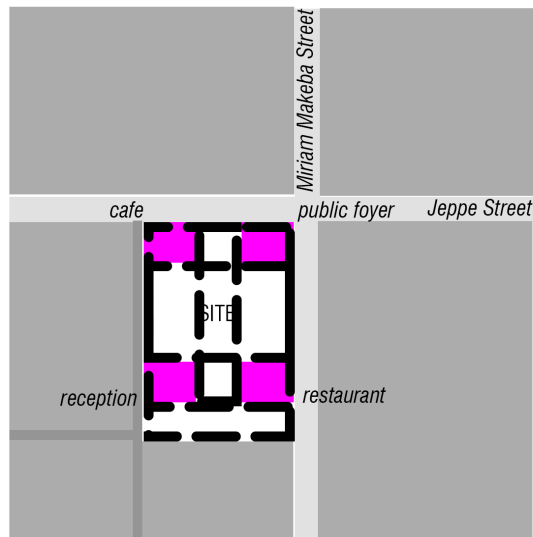

b | MAIN RECEPTION  
- visibility; accessibility

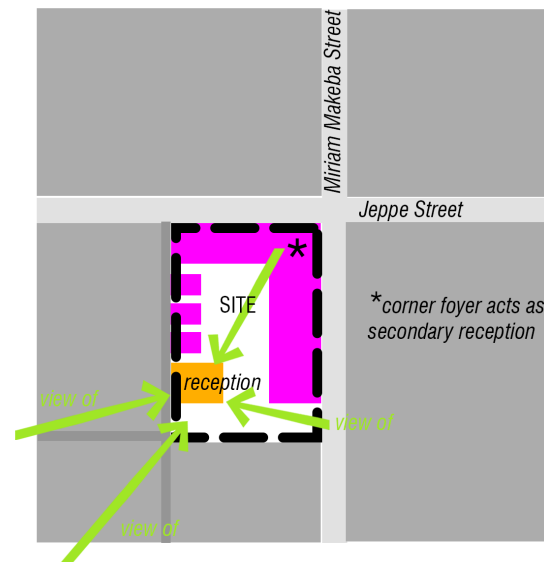

### 3.3 Zones

The architectural response to the concept of *Fragmented Unity* creates a building comprised of different zones, combining to form a holistic whole. The main building is comprised of four distinct zones, separated by service cores and movement joints. There are two additional zones separate from the main building.

Each zone has a distinct structural system determined by the grid spans and spatial volumes. The building zones all read similarly through their off-shutter framed concrete construction and same material palette, yet materially articulate their different street edge conditions and relationships to the internal courtyard as required.

*Zone A* covers the Artist and Artisan Studios, with the structural grid defining each studio space.  
*Zone B* defines the site corner where visitors are welcomed in the Exhibition Foyer.  
*Zone C* is the large, open volume of the hall.  
*Zone D* incorporates the restaurant.  
*Zone E* is the corner Reception, welcoming visitors from the Newton Park.  
*Zone F* incorporates the open Idea Interchange steel frameworks.

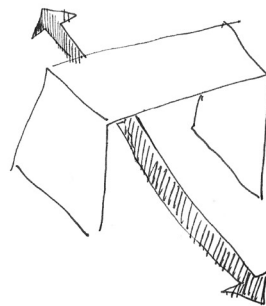
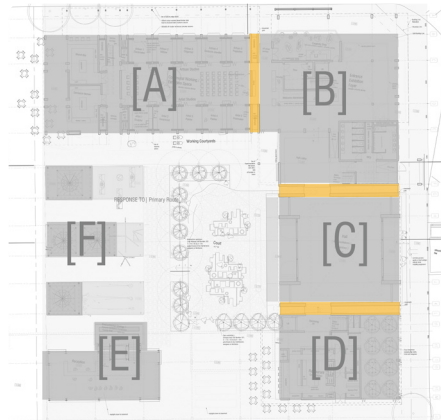

### 3.4 Programmatic Articulation

Visible connection is seen as a key concept in the Centre as it is a place for learning. It is important for visitors to be able to see what occurs in each zone so that they are enticed into actively participating in the offered programmatic components.

The building forms thus become open-ended boxes framing the internalised activities and leading on to the externalised activities.

A framework of structural grids create different sized spaces such that the Centre caters for a range of creative activities. Different sized spaces are also necessary in order for the changing needs of the Newtown Precinct to be accommodated as its character evolves.

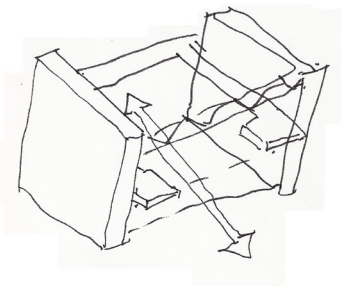

Figure 85: (left) Zone Diagram [Author, 2013]

Figure 84: (below) The importance of connection [Author, 2013]

Figure 83: (right) Birds-eye view looking North over the Centre from the South [Author, 2013]





- ① structure
- ② weather skin
- ③ environmental control

Figure 86: Northern facade fronting Jeppe Street [Author, 2013]

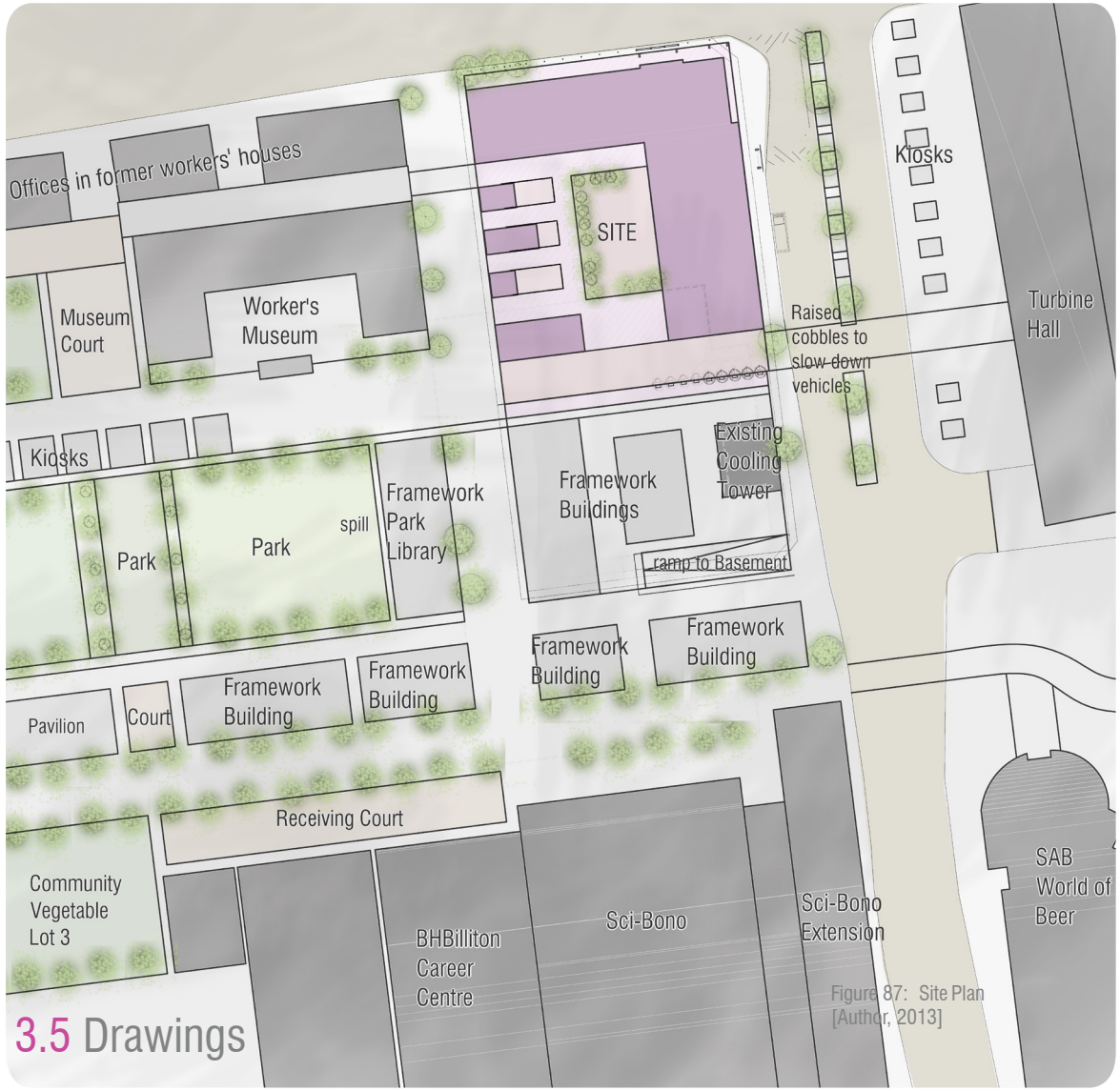

separate  
but  
combine  
for complete  
system  
'the whole > sum of parts'

### 3.5 Drawings

Figure 87: Site Plan  
[Author, 2013]



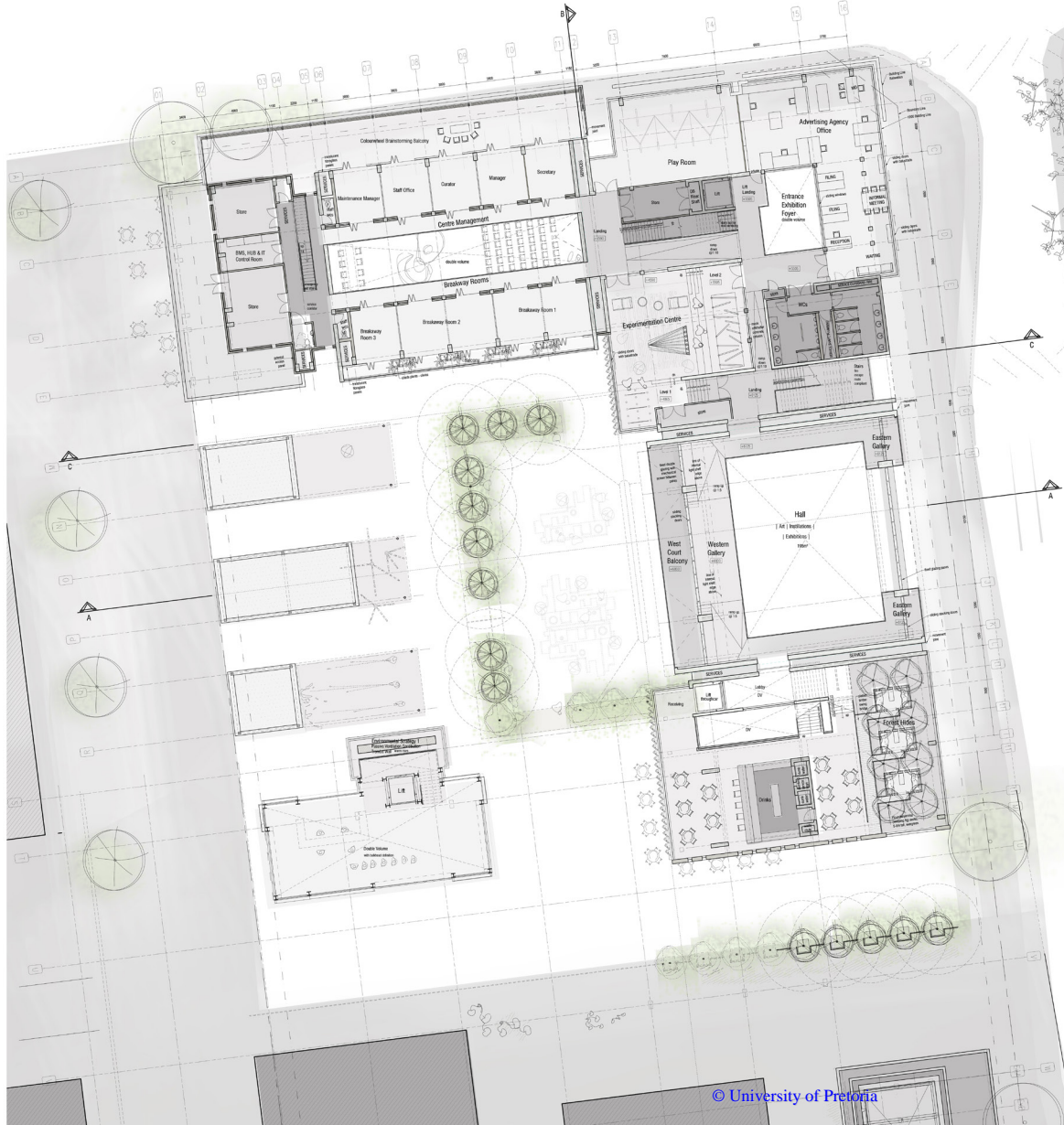

Figure 91: (far left) Ground Floor Plan [Author, 2013]

Figure 89: (left) First Floor Plan  
Figure 90: [Author, 2013]

Figure 88: (below) Restaurant Mezzanine Floor Plan [Author, 2013]

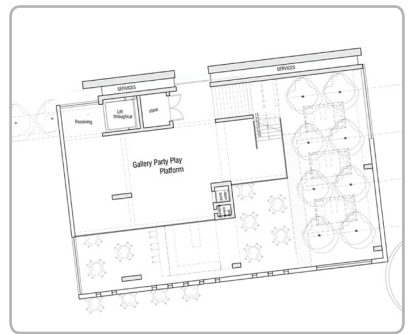





Figure 93: Enlarged view of First Floor Plan - Zone A & B [Author, 2013]

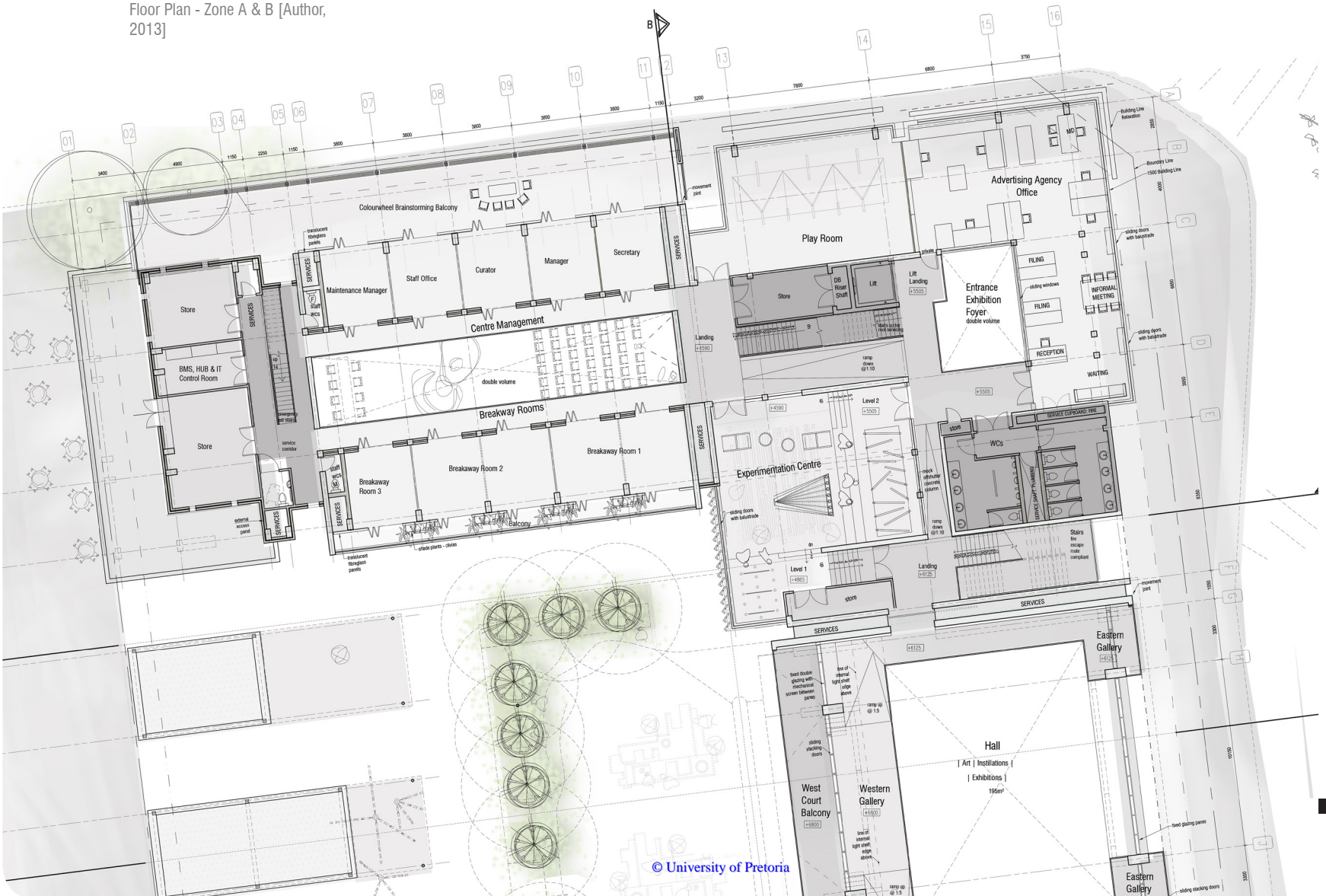



Figure 94: Enlarged view of Ground Floor Plan - Zone C & D [Author, 2013] © University of Pretoria



Figure 95: Enlarged view of First Floor Plan - Zone C & D [Author, 2013]

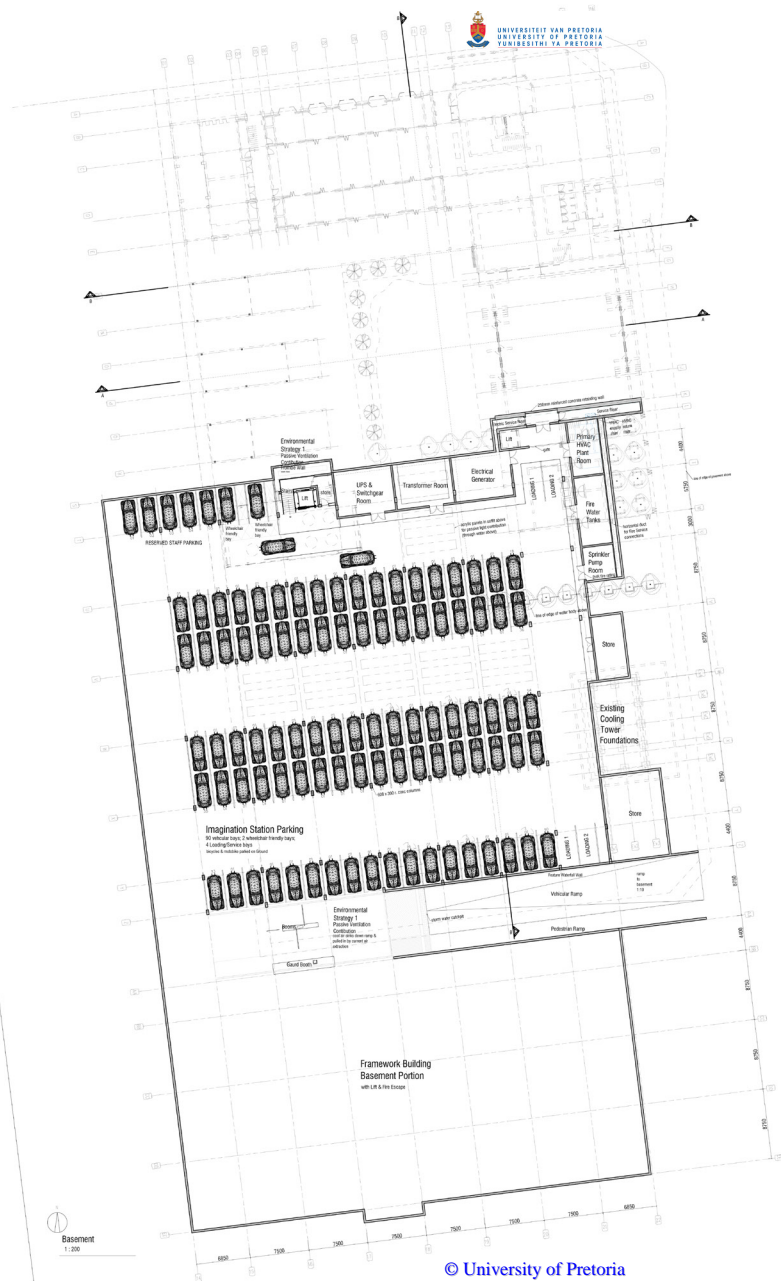
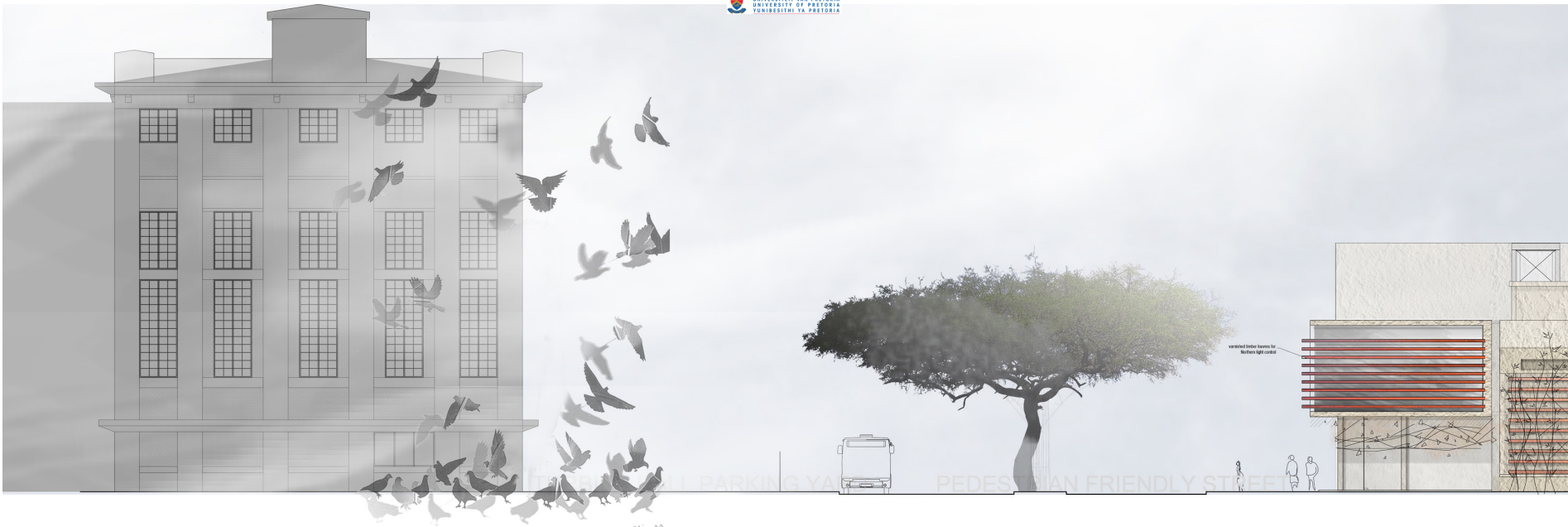
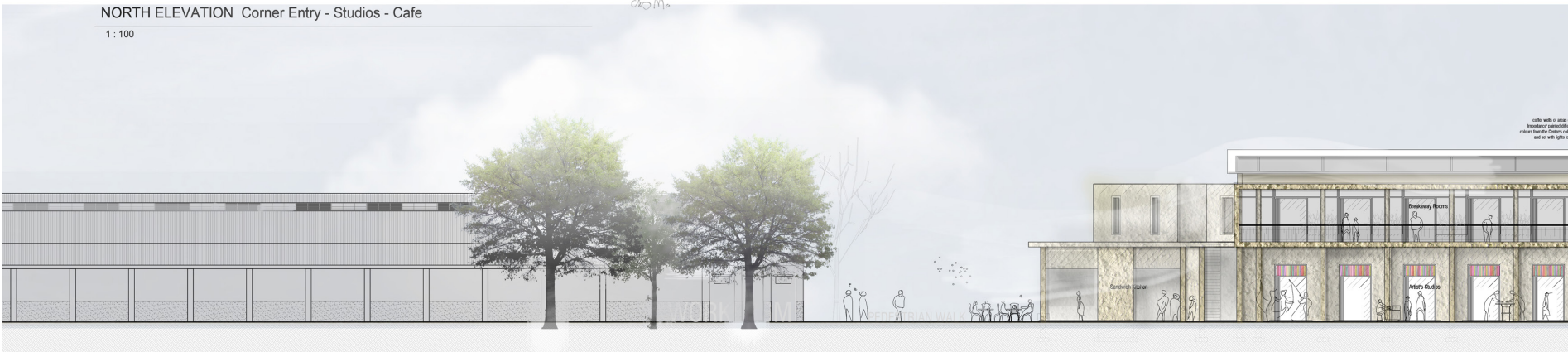

Figure 96: Phase 1 Portion of the Shared Super Basement between the Imagination Station and Sci-Bono [Author, 2013]



NORTH ELEVATION Corner Entry - Studios - Cafe

1 : 100



1 Artist's South Elevation

1 : 100

Figure 98:(left) North Elevation  
[Author, 2013]

Figure 97:(below) Artist's South  
Elevation [Author, 2013]

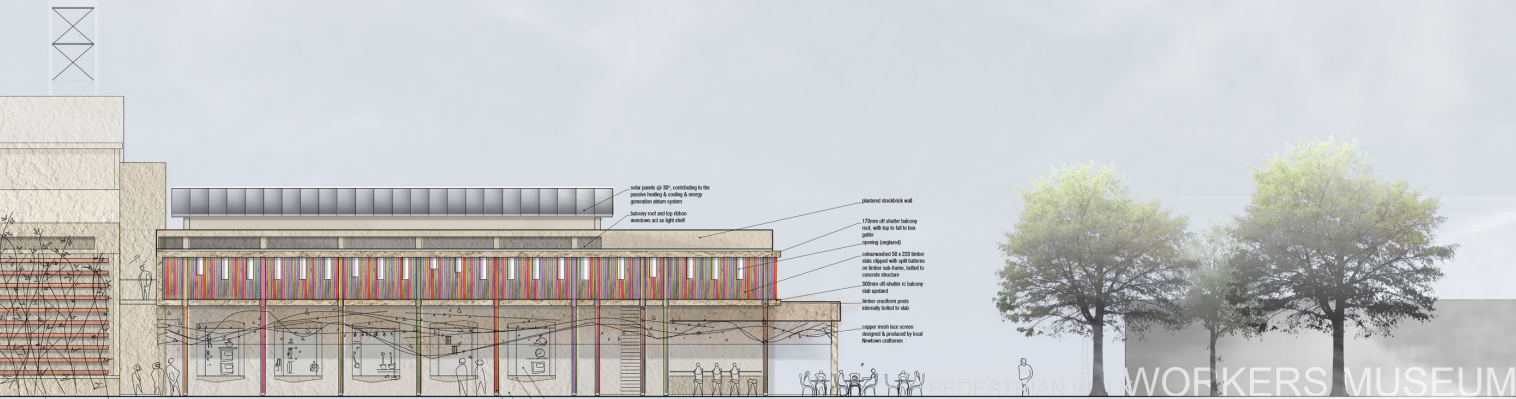

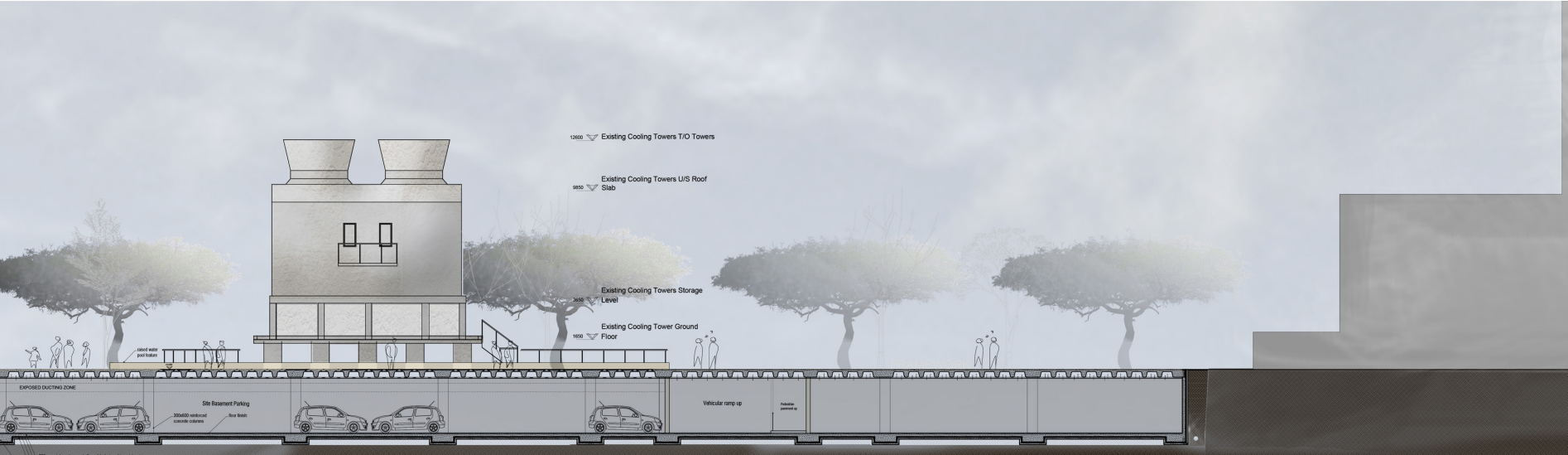



Figure 100:(left) East Elevation  
[Author, 2013]

Figure 99:(below) Section BB  
[Author, 2013]

JEPPE STREET



- 250mm reinforced concrete floor slab designed to resist water pressure on
- 300mm concrete screed on
- 10mm energy polyethylene waterproofing membrane to SANS 952 type C, joined by lapping and solvent welding, on
- 100mm surface seal
- reinforced concrete column loading



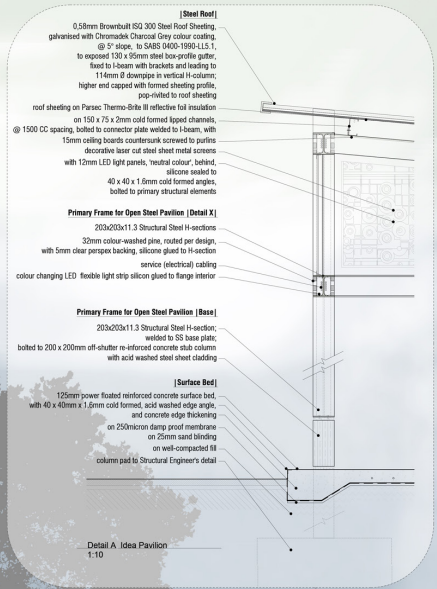

Detail A Idea Pavilion  
1:10

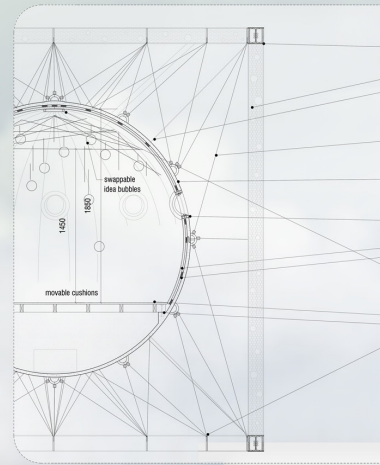

Detail B Idea Bubble  
1:10

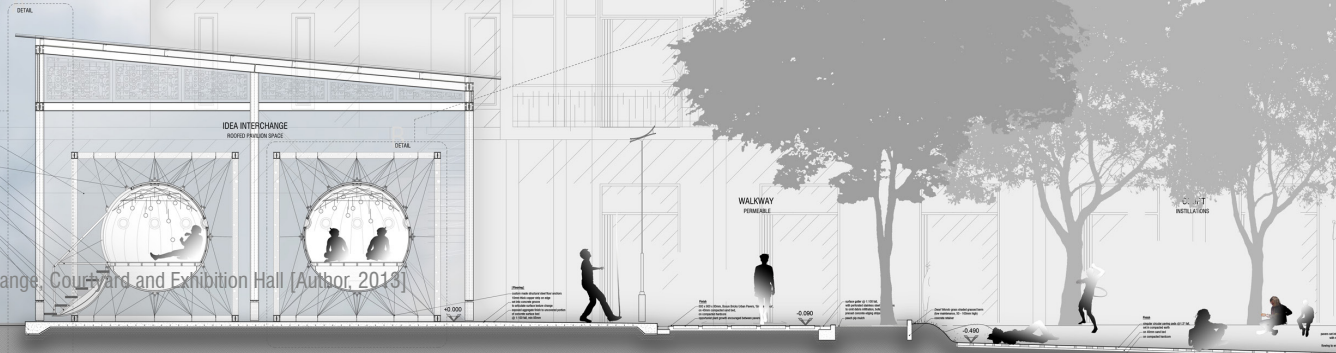
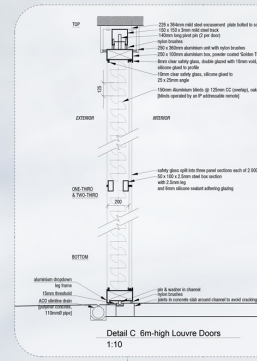

Figure 101: Section AA through Idea Interchange, Courtyard and Exhibition Hall [Author, 2018]



4.1 Introduction 4.2 Technical Concept 4.3 Technical Approach  
4.4 Concept Diagram for Each Zone 4.5 Precedent  
4.6 Material Palette 4.7 Material Study 4.8 Structural Systems  
4.9 Introduction to Passive Strategies  
4.10 Lighting 4.11 Heating, Cooling, Ventilation 4.12 Planting  
4.13 Construction Technology 4.14 Specifics

## 04 technical development

## 4.1 Introduction

The Technical Investigation takes the developed design and resolves key components.

The concept guiding the technological approach is first outlined; after which the material palette is defined.

The structural systems are illustrated, with such systems having been refined under the guidance of Structural Engineers Carl von Geyso and Kurt Waelbers.

The active and passive systems at work in the building are then outlined. Particular interest is paid to passive lighting and ventilation systems.

## 4.2 Technical Concept

Overarching Design & Technical Concept: *Fragmented Unity*

The technical concept is a continuation of the design concept of 'Fragmented Unity'.

### *Boxes on Legs*

As outlined in *Chapter 03 - Design Outcome*, the main building is comprised of four zones. The different zones all use off-shutter concrete as their primary structural expression, which unites their differences in a holistic entity. Each zone is in essence a concrete box on legs with framed glazing filling in the open sides parallel to the street.

The concrete framing is articulated through off-shutter texturing and formwork pattern-making. The robustness of the primary structural element is thus emphasised through the technical decisions relating to the concrete walls. The robust aesthetic is driven through the building's public nature in a precinct that

aims to be as open and as vandal-proof as possible.

The Zones share the same material palette, while the chosen materials are articulated differently in each particular Zone.

Overarching Technical Concept:

'Boxes on legs' relating to horizontal vs vertical planes

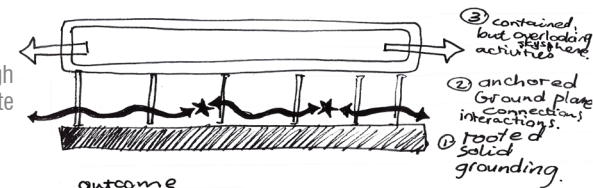

## 4.3 Technical Approach

### Systems

The *fragmented unity* concept is also shown through the singular building functions contributing to the greater holistic system of the entire workings of the building. The function of the component is therefore to be expressed in terms of itself *and* its position in the function of the greater whole, per the previously outlined *Gesamtkunstwerk* theories.

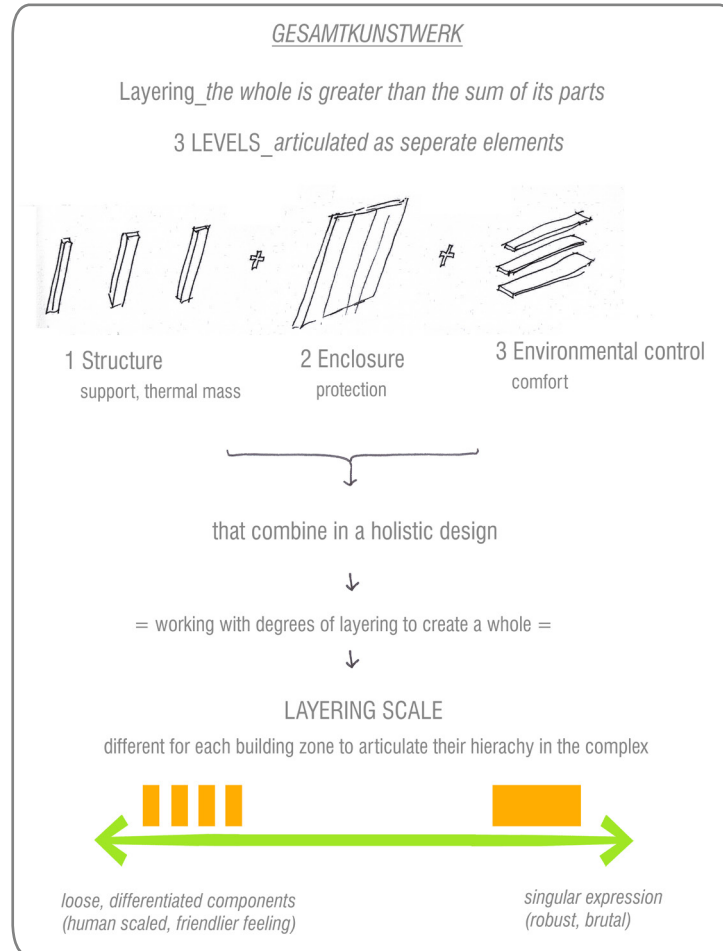

## Tectonic

### Relation to Learning

Since the building's program is one of creativity, a centre for exploration and learning, it is important that the building expresses how it works. This is following the notion that the building users need to start understanding how systems work in order to imagine alternatives for new creative modes of practice.

Materiality and construction of the connections and tectonics are therefore articulated. As an example, a door handle's functioning should be expressed instead of hiding such workings behind 'cladding'.

Figure 102: (right) Expressing the workings of components to encourage learning [Author, 2013]

Figure 103:(top right) Zone Diagram [Author, 2013]

## Particular Links

- Steel structures link to the past Industrial Age of Newtown's power supply heyday; while furthering the contemporary industrial notion of the Third Industrial Revolution.

- Wood is used to add tactile softness to the harsh urban environment, while carrying important symbolism with regards to connecting to the three former cooling towers that once occupied the site.

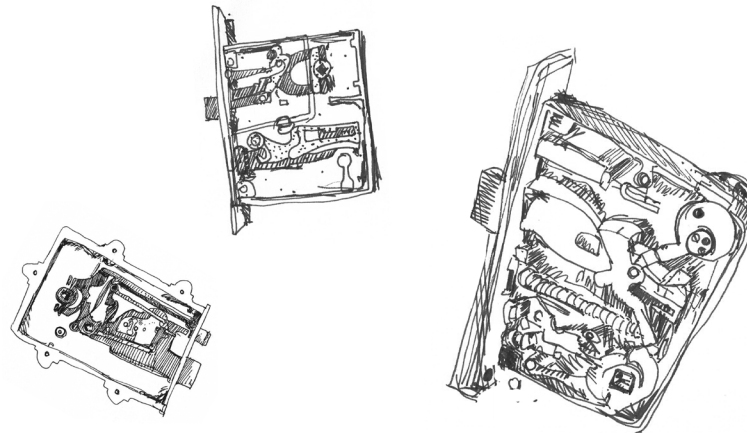
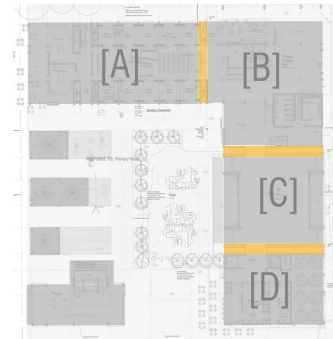

## 4.4 Concept Diagram for Each Zone

### Zone A: Artist's Studios

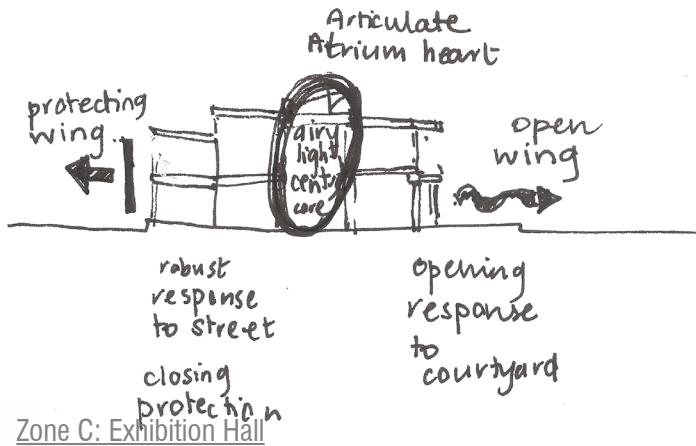

### Zone B: Corner Lobby

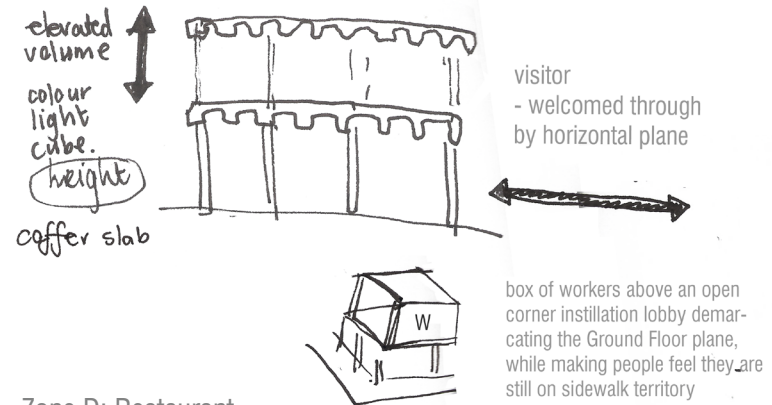

### Zone C: Exhibition Hall

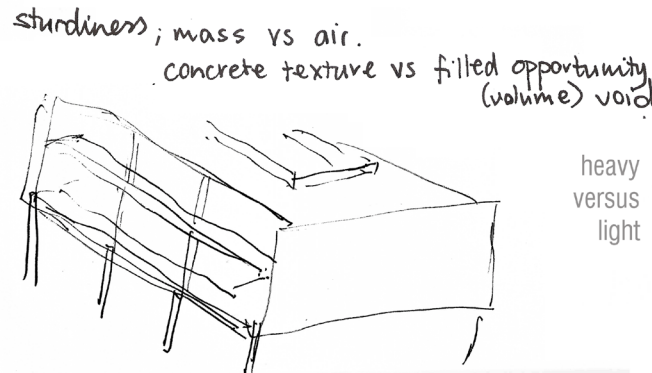

### Zone D: Restaurant

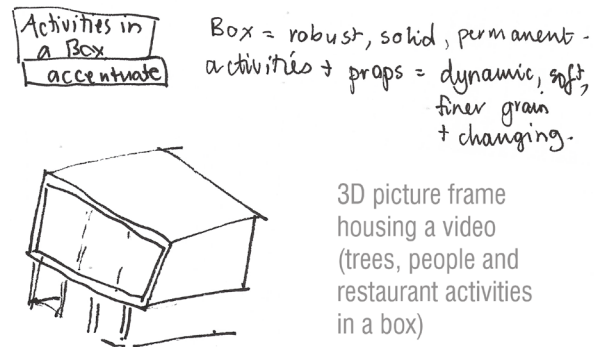

## 4.5 Precedent

### 1 | Centre Pompidou

The Centre Pompidou by Renzo Piano and Richard Rogers functioned as precedent for the treatment of paving in The Imagination Station. This singular feature is seen to create a more holistic dialogue between the Centre Pompidou and its relating external activity court than if the courtyard was at less of an inclination. The gradient of the courtyard falling towards the Hall in The Imagination Station was therefore specifically analysed in order to accentuate the Hall.

### 2 | SEED

The colourful treatment of the facade of the Architects of Justice's SEED Project inspired the development of the The Imagination Station's Northern, Jeppe Street Facade to include colour-washed timber panels to liven the building's most public street edge.

### 3 | Industrial Volumes

Industrial buildings were analysed in terms of the structural systems for The Imagination Station Hall due the large open floor plates

of Industrial building designs. The method of roofing and structural roof support was explored in terms of an appropriate strategy to accommodate the Hall's requirements.

### 4 | Wits Art Museum

The Wits Art Museum (WAM) by Architects Fiona Garson and Nina Cohen was analysed in terms of its treatment of the corner and means of allowing building elements to be artistically appropriated.



Figure 104:(top) Paved gradient falling towards the Centre Pompidou [Mirza ,2012 :(online)]



Figure 105:(middle) Coloured slats create a lively atmosphere in The SEED [AOJ, 2013:(online)]

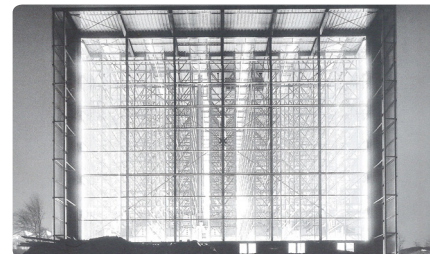

Figure 106:(bottom) Inspiration for hall volume and glazed facade treatment of a 'box' structure [Adam *et al*, 2004]

Figure 107:(far right) Technical elements of the WAM include the openable Ground Floor Plan; WAM's glazed Ground Floor Facade is open to appropriation, as seen with the digital display viewed from the street; while the interior Lobby is seen to be able to cater to a range of events [WAM, 2013:(online)]





## 4.6 Material Palette

*Gesamtkunstwerk* theoretically governs the material palette through assembling a hierarchy of specified materials in a 'total artwork'. The overarching notion is of concrete boxes on legs with glazed infill.

The Primary Material Palette, as derived from the primary structural system is therefore off-shutter concrete.

The Secondary Material Palette includes steel, brickwork and glass.

The Tertiary Material Palette includes decorative metalwork, copper, colour-washed timber slats and planting.

The tertiary materials create a layering to the primary and secondary palette materials through mainly being used in craftsmanship components, such as hand-crafted metal screens and balustrades.

Figure 108:(opposite page from top left) *Materiality, Finishes, Textures & Tones*: texture and appropriation of off-shutter concrete [Nasple, 2004]; power floated floor finishes, with oxide additives for spatial differentiation; the soft visual texture of bamboo as the walls and flooring of the Idea Interchange Capsules [Trade brochures, 2013; craft aesthetic in metal screens as tertiary palette [Author, 2012]; acid washed steel in finishes such as concrete slab edging strips; neutral colour tones offset by colour highlights to accentuate key areas; copper detailing; fritted glass for patterned sun control [Trade brochures, 2013]; precedent of hanger doors for large openings [ReidSteel, 2013]

## 4.7 Material Study

### Area Materiality Precedent

As Johannesburg's former Electricity Generation Centre, Newtown's historic buildings relate to the Precinct's industrial heritage. Such buildings are either large scale concrete framed, brick infill edifices; or less notable, metal framed and sheeted warehouses.

Successful contemporary buildings have drawn on Newtown's rich architectural heritage in modern ways. Contemporary buildings are seen to utilise facebrick, off-shutter concrete or structural frame articulation to relate to Newtown's built environment.

Figure 109: Newtown's historic buildings (right column) compared to their contemporary counterparts (far right column) [Author, 2012]





Golden Touch 9068182K  
RGB 149.9 131.4 106.4, LRV 2

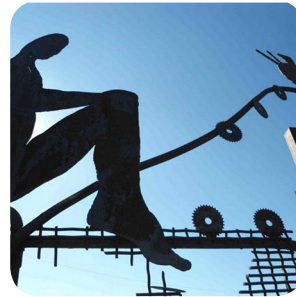

## 4.8 Structural Systems

The structure is divided into Primary, Secondary and Tertiary components

### [1] Primary Structure | *Loadbearing* |

The primary structure is loadbearing, off-shutter concrete. Since the building is public in nature, the detailing speaks of robustness, such that the primary structure is expressed.

### [2] Secondary Structure | *Skin* |

Infill closes the openings between the primary structure. Brickwork or aluminium-framed glazed walls are utilised. Each zone's concept and hierarchy in the total building complex governs whether the infill sits between or is offset from the primary building structure.

### [3] Tertiary Structure | *Environmental Control* |

The tertiary structure provides environmental control in the form of louvres to adjust light quality per user requirements and comfort. Such elements are seen as finer membranes over the chunky primary structure. The tertiary structure therefore provides a finer, human-scale to the more robust primary structure.

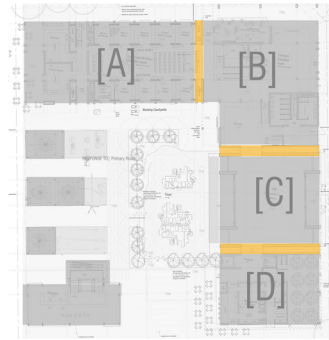

### Zone A

The structure for the Artist's Studios defines each studio's working space. The reinforced off-shutter concrete columns take the load down from the reinforced concrete slabs around atrium. The Structural Engineer advised that no beams are required due to the tight column grid. The column grid arose from the programmatic definition of the space required for each studio. The structural spacing therefore came secondary to the programmatic requirements.

### Zone B

Zone B utilises coffer floor slabs due to its large volumes and larger spaced column grid. The coffer wells are appropriated by being painted different bright colours, with lights reflecting into each well from below.

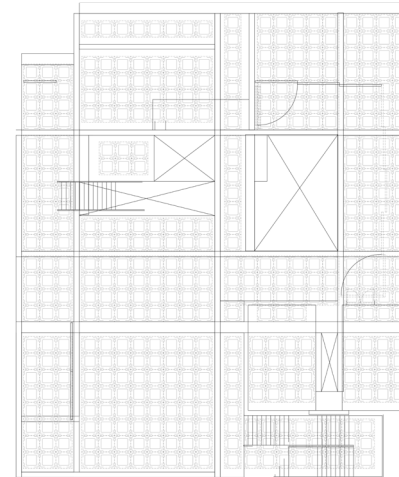

Figure 110: First Floor coffer slab layout for Zone B - Foyer - showing double volumes and vertical service penetrations [Author, 2013]

## Zone C

The Hall's two North and South end walls are seen to provide support to the reinforced Gallery floor slabs and roof with the help of four columns. The roof has a reinforced concrete ringbeam comprised of a slab and two upstands on either end, running 360° with an open well in the middle. The Hall's structural steel trusses are bolted to the North and South faces of the ringbeam's interior upstand.



Figure 111: Zone B coffer slab lighting appropriation [Uni-span, 2013]

An alternative option of having a thinner ring beam slab with beams carrying the slab was superseded due to the functionality of wanting to keep the ring beam open as a roof gutter. Different truss options were investigated, including tensioned timber roof members, however, the investigation concluded with normal structural steel sections being used due to the requirement of needing to suspend exhibition installations, lighting and equipment from members.

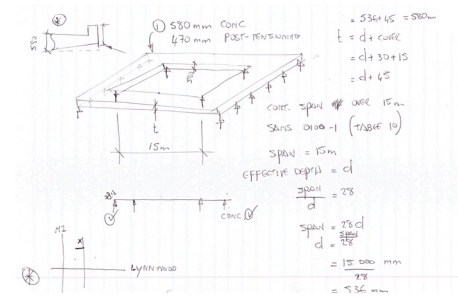
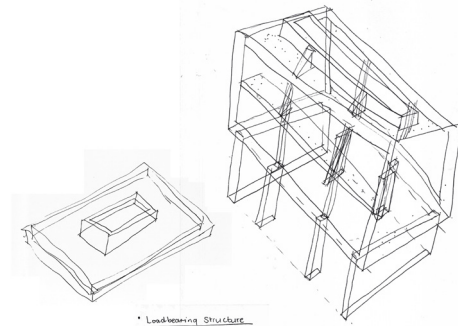

Figure 112: Zone C - Hall - Structural Sketch and Exploration with Structural Engineer [Author, 2013]

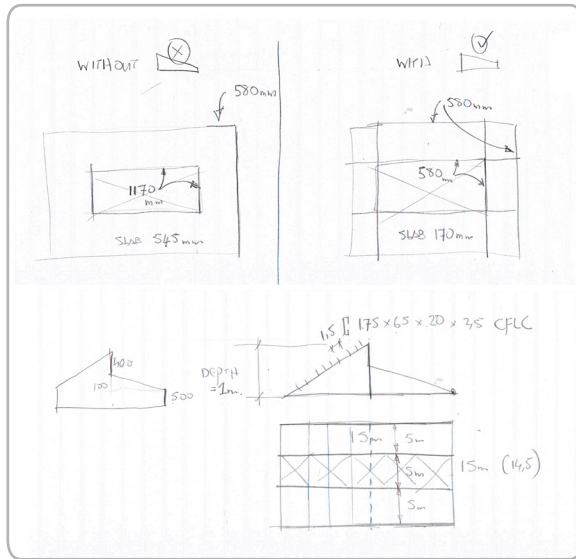
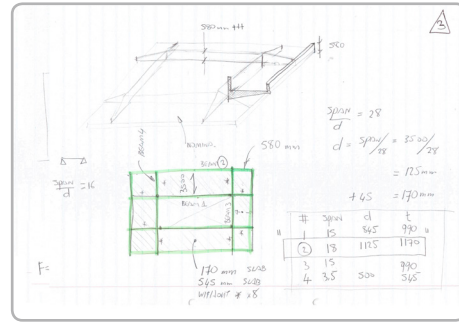

Figure 113: (full spread) Zone C - Hall - Structural Sketch; Model and Engineer's member size calculations [Author, 2013]

DL = 0,2  
LL = 0,5  
m = 0,1  
FINSL = 0,2

1 kPa BM =  $\frac{1}{8}(1)(15)^2(5) = 140 \text{ kNm}$   
 $F = 140 \text{ kN}$   
 $l = 3 \text{ m}$   
 $\Gamma = 100 \times 100 \times 10 \text{ L TOP \& BOTTOM}$   
 LACING =  $80 \times 80 \times 8 \text{ L}$

$F = \frac{1}{2}(15)(5) = 37,5 \text{ kN}$   
 $l = 1 \text{ m}$

STRADES

GOOGLE:  
CONCRETE LIFTING LUG

580 mm CONC. SLAB WITH HORIZ STAYS OR  $\perp$  STAYS  
 330 mm " " WITH 45° STAYS.

span/d = 28 CONC  $d = 285 + 45 = 330 \text{ mm}$   
 span/d = 35 POST TENSIONED CONC.  $d = 220 + 45 = 265 \text{ mm}$

per 1000 summer  
 $\Delta L = \Delta T \alpha L$   
 $= 20 (10 \times 10^{-6}) 18000$   
 $= 4 \text{ mm}$

### Zone D

Zone D structural components include reinforced columns, beams and slabs forming mezzanine levels.

## 4.9 Introduction to Passive Strategies

Lighting, Heating, Cooling and Passive Ventilation are explored as these mechanical systems are seen to comprise a total 73% of a building's energy consumption.

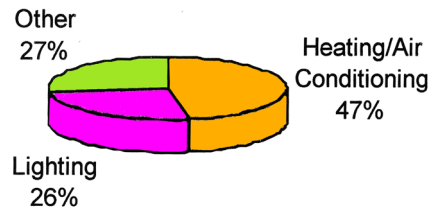

Figure 114: Break down of the components comprising a building's energy consumption [Grobler, 2002:15]

### 1 | Lighting

Natural lighting is promoted in the Centre for its quality as well as reducing electrical lighting loads. Natural light is directed or filtered as required per each space's programmatic use. Mechanical lighting employs energy saving fittings to reduce electrical consumption.

### 2 | Heating, Cooling, Ventilation

A system of coupled earth tubes is utilised for passive heating, cooling and ventilation. Where required, solar powered fans are utilised to promote air extraction from the upper levels.

A small, attractive water feature on the south side of the main building provides a dual function of contributing to the creation of a pleasant environment while being used as the source for the earth tubes' passive ventilation and cooling system.

### 3 | Planting

Planting is similarly utilised to create pleasant human-scaled environments that are as attractive to users as functional in terms of offering shade, particularly in the courtyard in hot summer afternoons. Evapotranspiration of deciduous courtyard trees adds to cooling the Centre in Summer.



## 4.10 Lighting

### Introduction

Lighting strategies aim to control direct light in order to promote user comfort, while passively utilising the light to lower mechanical lighting use in order to save electricity.

As a general strategy, Northern light is filtered or bounced via light shelves to reduce its intensity. Design devices encourage Southern light penetration for its softness in the Artist's Studios and the Hall. Turbine Hall predominantly blocks the direct Eastern, early morning light by its scale, while the existing fever tree avenue on Miriam Makeba Street softens any late morning light. Vertical louvres are designed for the Western facade to omit late afternoon light.

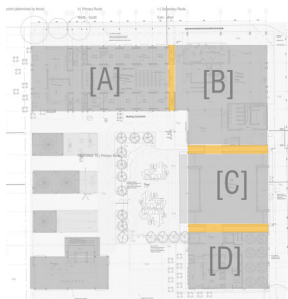

### Specific Zones

#### Zone A

The Ground Floor Studios are sheltered from the direct Northern Light through the design of a pedestrian colonnade, with Cape Town's Long Street providing an apt precedent. Refer to *Figure 115 on page 181*. Northern light bounces off the balcony roof in order to provide the First Floor offices with an even distribution of less intense, reflected light.

#### Zone B

A gridded formation of point lights suspended below the coffer slab, with each light point projecting into a painted, reflective well has been designed for the Foyer. The Foyer's soffit thus expresses the creative nature of the Centre through the illuminated colour wells, as an unobtrusive means which does not detract from art installations below.

Horizontal, timber louvres filter the First Floor Office area. A large-scale crafted metal screen filters the North light from directly entering the Art Retail shop front. The screen is set away from the shop front to act as a predecessor to the start of the colonnaded walkway.

#### Zone C

The Hall opens on an East-Westerly axis, such that morning and afternoon light are viewed as the main lighting concerns. The ground plane uses adjustable louvres designed into the double glazed sliding stacking doors to omit undesired light or visually close the Hall for private functions.

The East and West facades of the Hall's First Floor Galleries incorporate mesh screens hung from the external soffits to filter the afternoon light down to 20% emittance. The glazing's lower pane is fritted with craft patterning in order to diffuse late afternoon light not caught by the upper screens.

The Hall permits Southern light to infiltrate through the large roof light to provide apt, soft exhibition light.

#### Zone D

External vertical louvres omit Western light, while adjustable custom-made umbrellas are opened over external Ground Floor restaurant tables, adding animated activity to the edge of the square in their opening and closing.

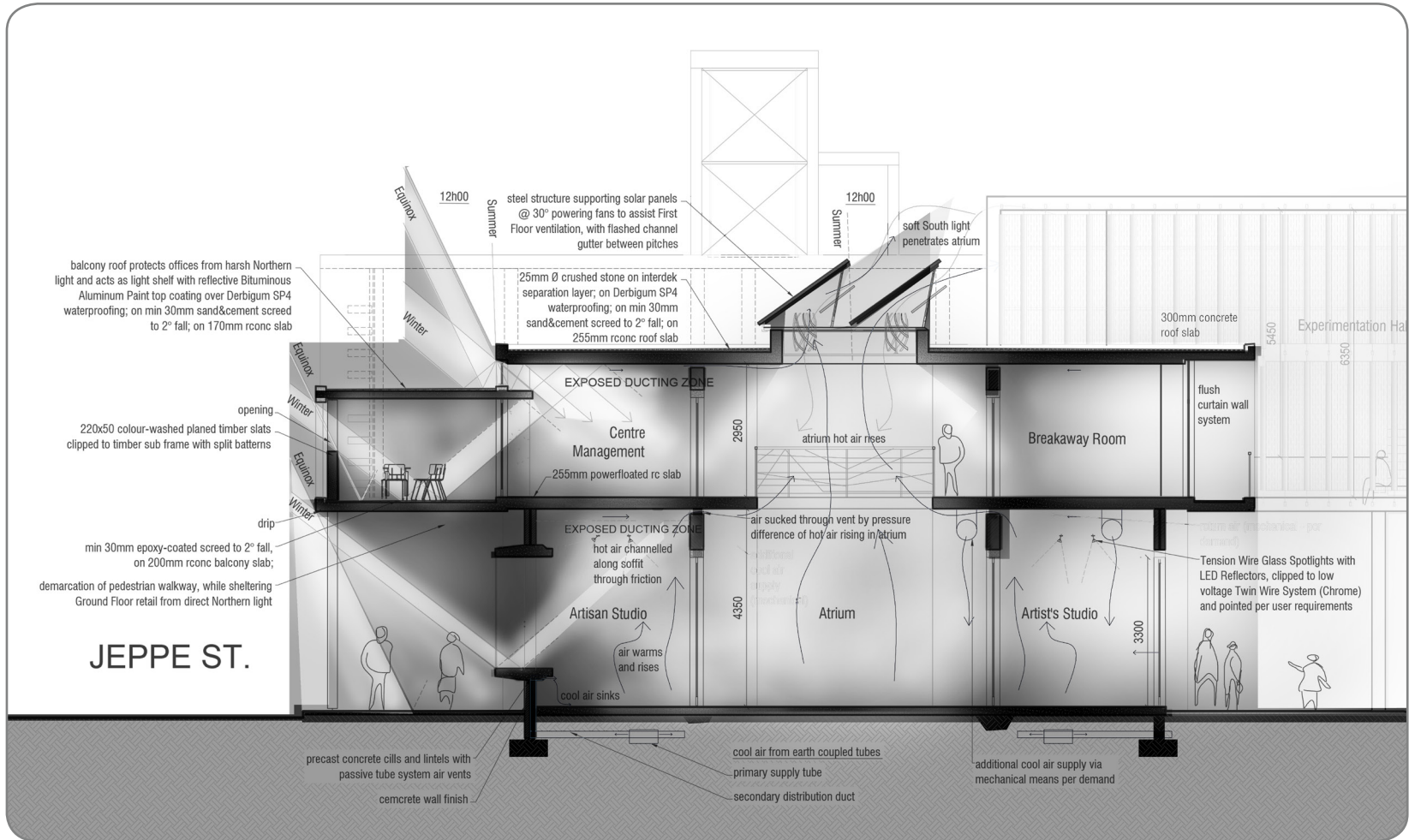

Figure 115: Zone A - Passive Lighting Strategies [Author, 2013]

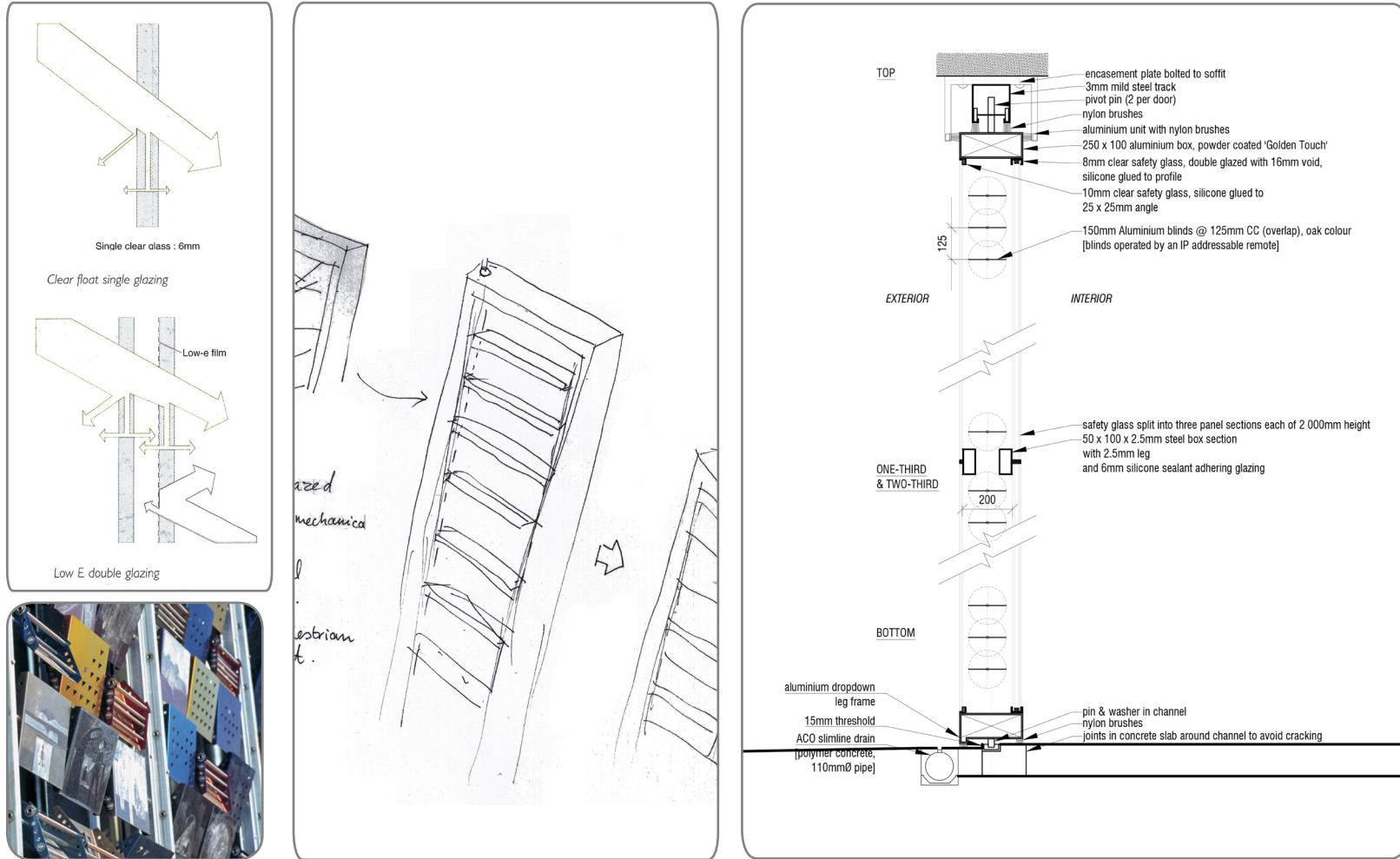

Figure 116:(above) Looking at the effects of double glazing with reference to the Hall's glazed doors facing West [Owen Lewis, 1999]; Craft aesthetic for louvres as shown at The Constitutional Court [Law-Viljoen, 2008]; Concept of adjustable louvres inside the Hall's doors [Author, 2013]; Detail of 6m high double glazed doors with internal louvres [Author, 2013]

## 4.11 Heating, Cooling, Ventilation

Coupled Earth Tubes are utilised to draw fresh air from the South side of the main building. Each zone has its own loop as shown schematically in *Figure 118 on page 184*.

Due to the earth's crust ambient temperature being approximately 18°C, the fresh air cools the spaces in Summer, while bringing in air that is relatively warmer than the ambient air temperatures in the Winter months.

The gaining of cool air is assisted by fans in the vent pipes at the collection point. The coupled tubes loop back and forth in the soil before being brought up to surface in the Ser-

vice Core Shafts. Air is then channelled and infiltrates the spaces through vents set into the off-shutter concrete service walls.

The cool air will heat and rise due to activities in the spaces. Spaces without enough vertical distance to induce a stack effect, such as the offices on the First Floor of *Zone A*, have solar powered extraction devices to aid the passive systems.

Pitched roofs are utilised in the other zones to induce the warm air to flow up and out of the zone.

The paired off-shutter concrete service walls provide thermal mass to the relatively open spatial volumes. Such thermal mass assists in modifying the air temperature by storing heat from the day and releasing it during the cooler nocturnal period. This is done until the walls cool and begin to store the cool from the night which is in turn released during the morning.

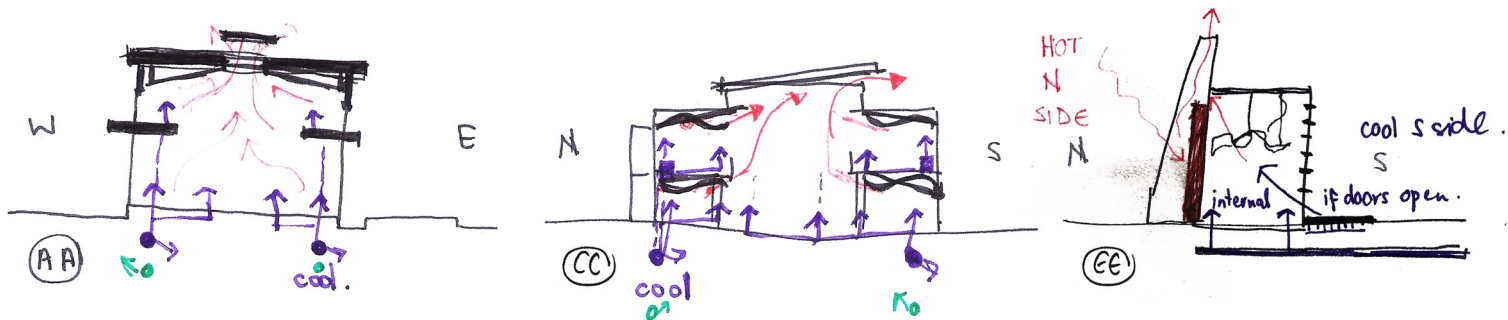

Figure 117: Passive air flow strategies through the Hall (Diagram Section AA); Artist's Studios (Diagram Section CC) and Reception (Diagram Section EE) [Author, 2013]

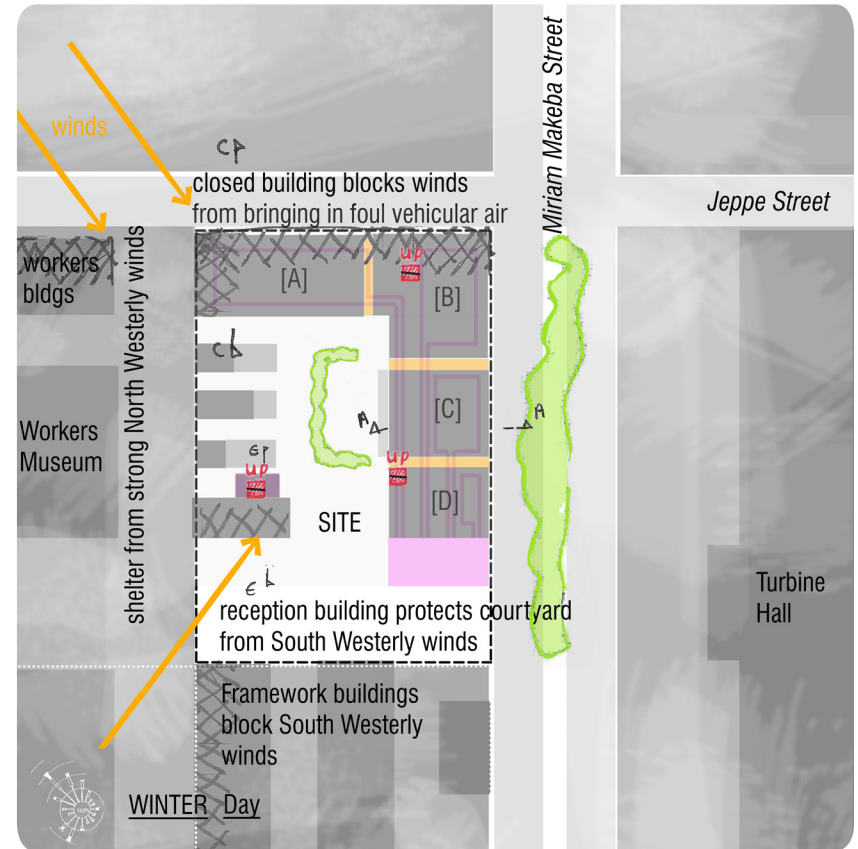

Figure 118: Schematic plans of passive ventilation systems [Author, 2013]

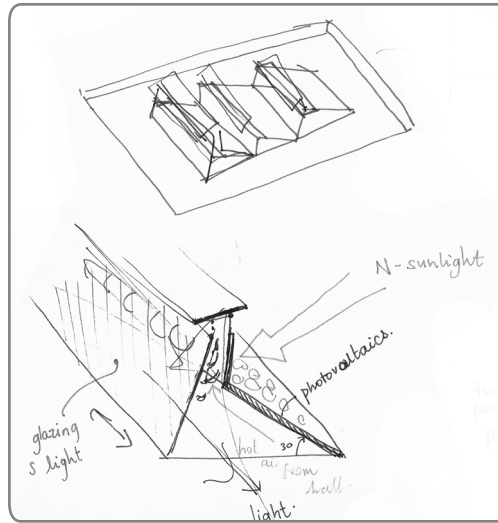

Figure 119: (top left) Sketches exploring devices and systems for passive ventilation, cooling and heating; (top right & bottom) Plan and section showing spatial definition through planting [Author, 2013]

## 4.12 Planting

As previously outlined, planting is used as a means to define space, create a pleasant environment and add to sustainable practices.

The planting is chosen according to the criteria of being indigenous; filling the height minimums and maximums in order to appropriately define the designed space; having the desired density of foliage with dappled instead of solid shade being sought; appropriate shade or sun variety; as well as the appropriateness of evergreen or deciduous planting. The aggressiveness of the vegetation's root system is also taken into consideration.

Secondary considerations included plants that would add to the nature of the Centre in terms of articulating and fostering creativity. This is achieved through vegetation that has unusual foliage, seed clusters or blossoms. Trees that attract birds and insects were also favoured to add to the friendly, community spirit of the Centre and promote a holistic environment in the urban setting. Deciduous trees are mainly specified to allow the winter sun to penetrate and warm up the Centre, as well as changes in their foliage importantly expressing seasonality so that the Creativity Centre is seen to change upon subsequent user visits.



Figure 120:(anti-clockwise from top left) *Craibia zimmermannii* for the larger courtyard defining border; *Dais continifolia* L. for the smaller courtyard trees offering unique pompom clustered blossoms in Summer; Tree Wisteria as a smaller courtyard tree; *Ficus Benjamina*, indigenous, but one of the few trees able to be grown indoors; Dwarf Mondo grass, indigenous, but requires minimal maintenance and creates a pleasing aesthetic between paving [SANBI, 2006]

## 4.13 Construction Technology

### [A] Courtyard & Paving

Different paving options were investigated for the central courtyard in order to create the right community environment. The final outcome was custom made circular concrete pavers of four different modular sizes fitting next to one another in a seemingly random pattern.

Figure 122: Circa Gallery Precedent by StudioMAS Architects [Author, 2011]

Figure 123: Circular motifs portray a vibrant atmosphere [Trade brochures, 2013]

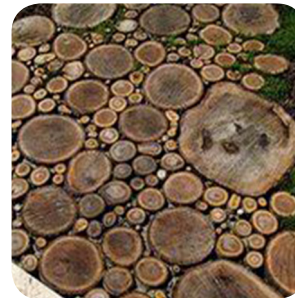

### [B] Waterproofing

The ACO Slimline Drain is specified outside the Hall threshold as a neat, inconspicuous water drainage method.

Penetron waterproofing slurry is utilised for waterproofing the horizontal concrete structures.

Figure 121: Aco Drain components [Acodrain, 2013]



#### ACO Slimline® accessories

##### Description

Sump unit with galvanised steel bucket and cover

Inspection unit with cover

Closing endcap

Drain union Ø110mm

Drain union Ø160mm

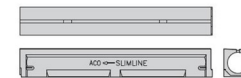

ACO Slimline® channel



## 4.14 Specifics

### [A] Idea Interchange Suspended Bubbles

The Idea Interchange functions as Zone F, which is comprised of rectangular, open-structure pavilions that house the interchangeable Idea Bubbles. These bubbles are suspended from a square structural steel frame. They were originally designed to be made from metal sheeting clad over a frame, but due to construction practicalities, the Bubbles will be pre-cast in 30mm thick panel segments from fibre-reinforced concrete.

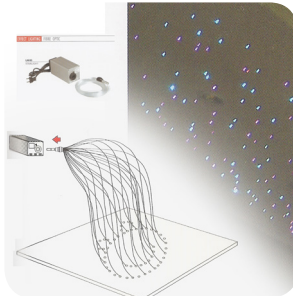

Figure 124: Lighting to be set against the steel box framework and in the suspended bubbles

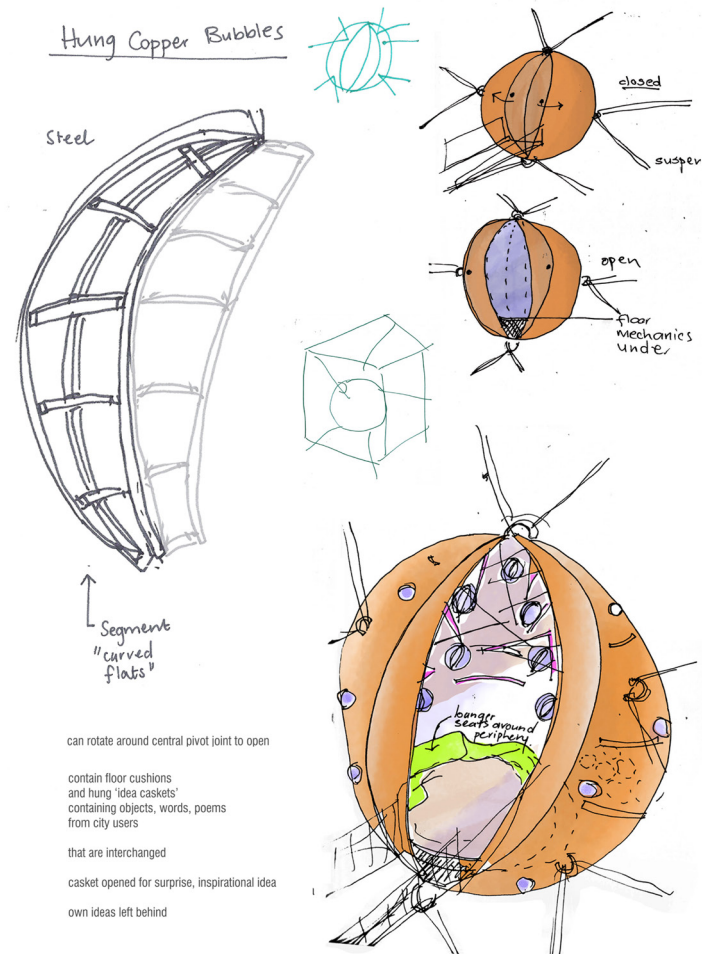
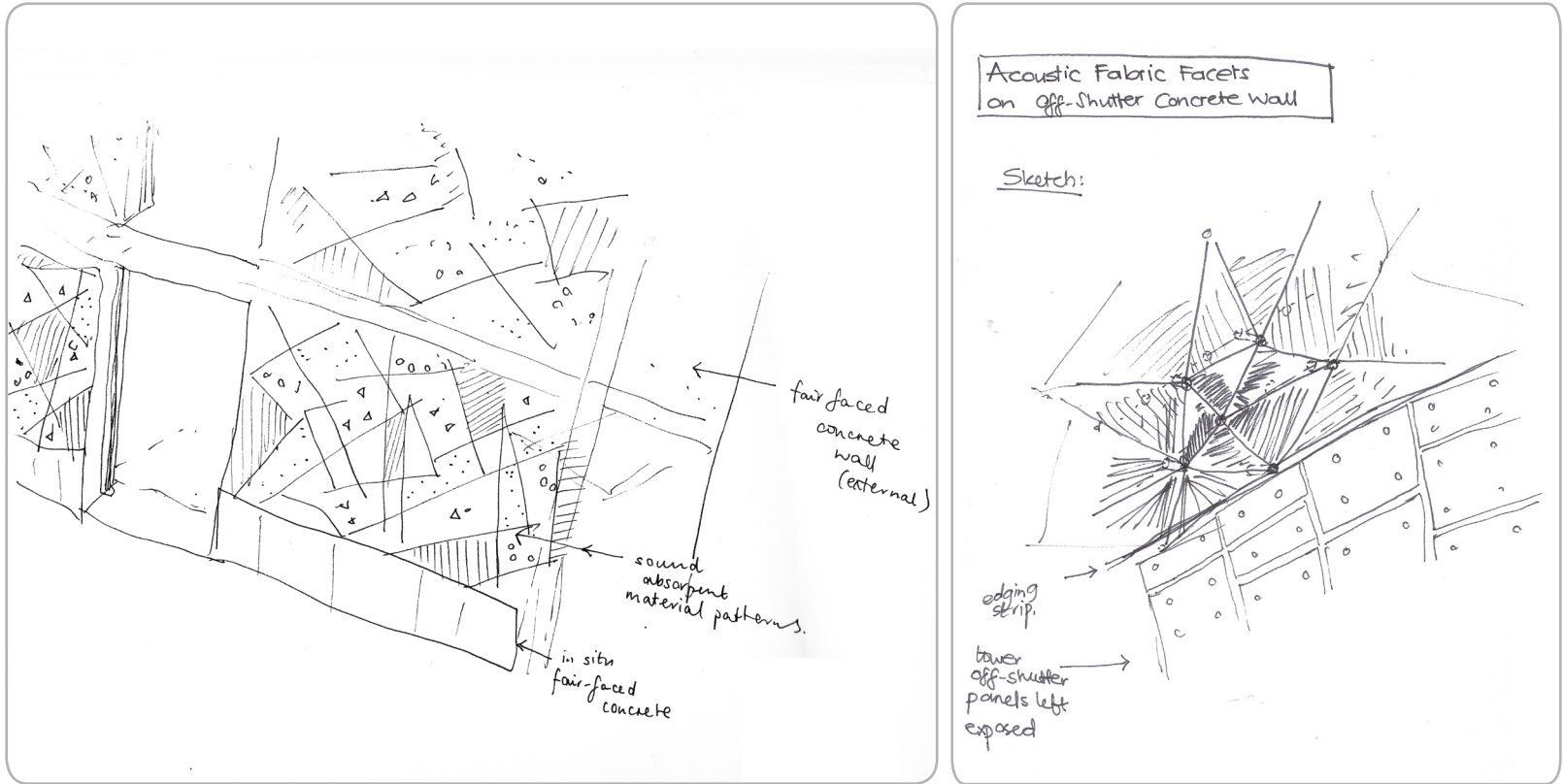
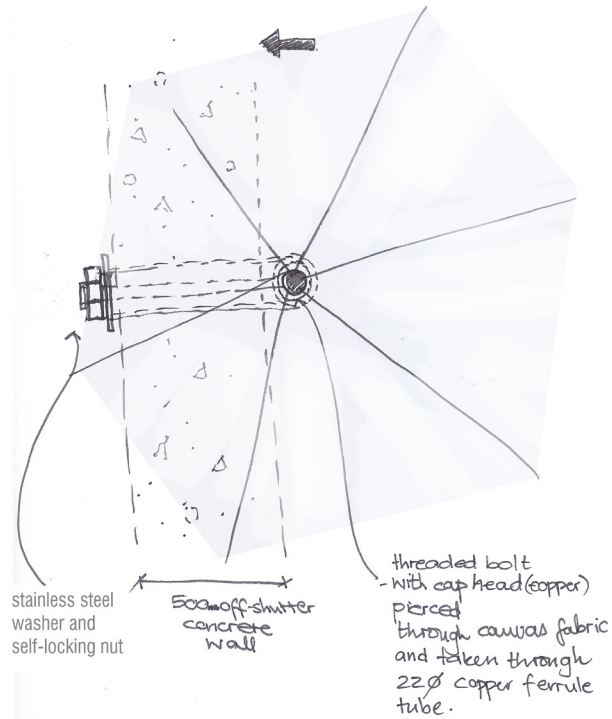

Figure 125: Exploration of Acoustic Wall Baffles for the Hall as seen in Section AA [Author, 2013]



Ⓐ Fabric Pulled In:



Ⓑ Fabric Pushed Out:

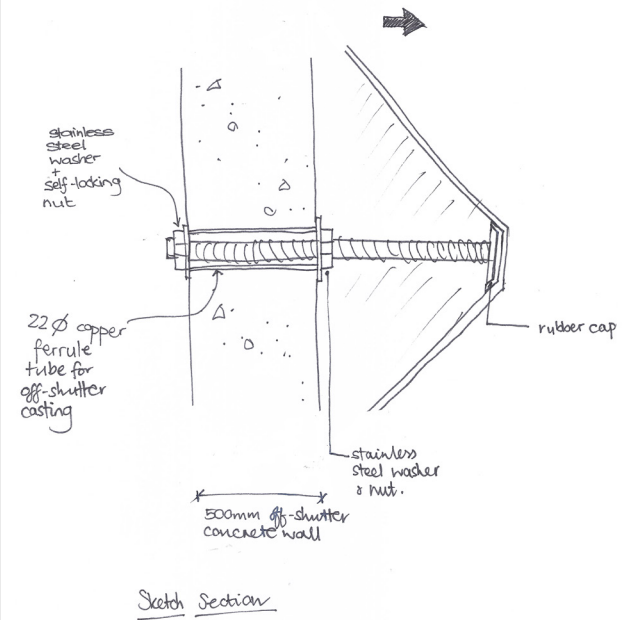

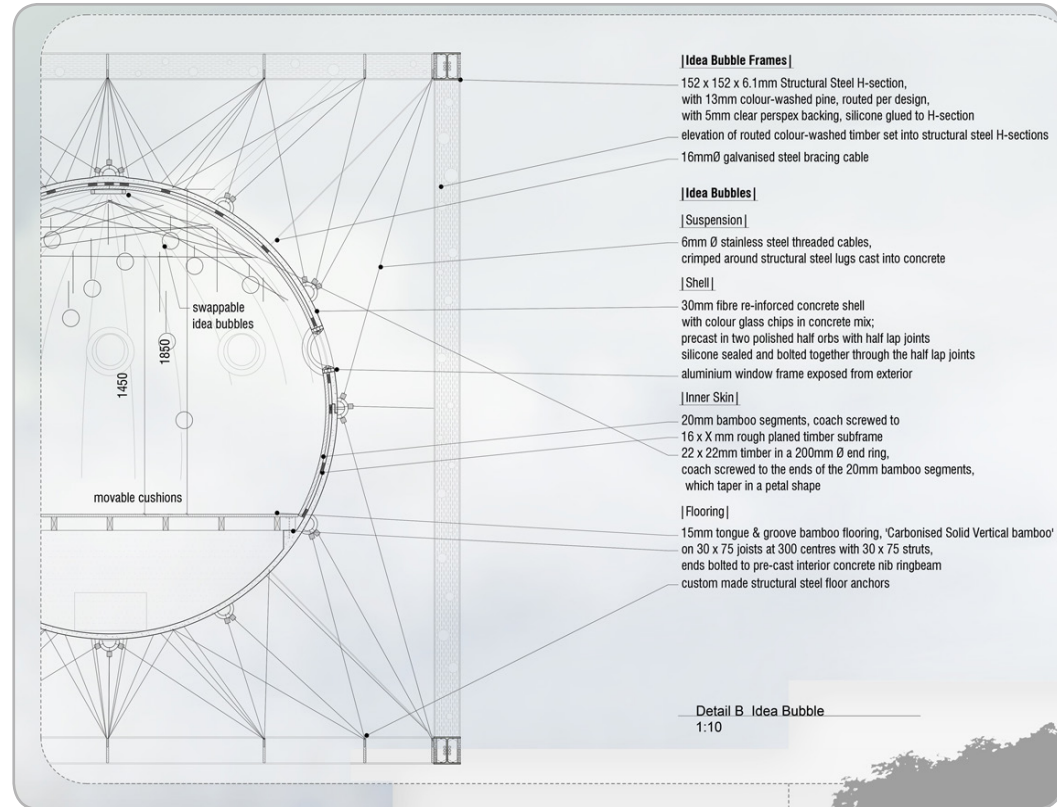
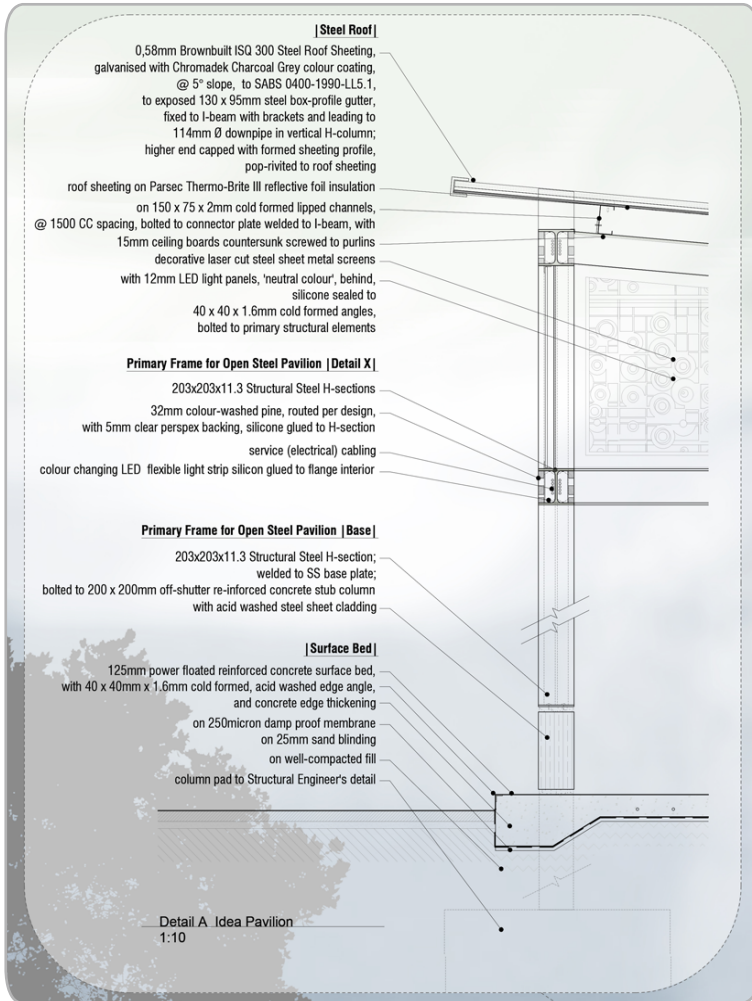

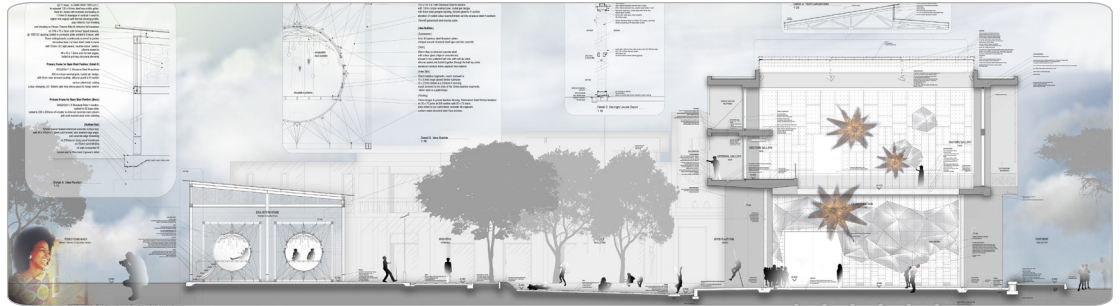
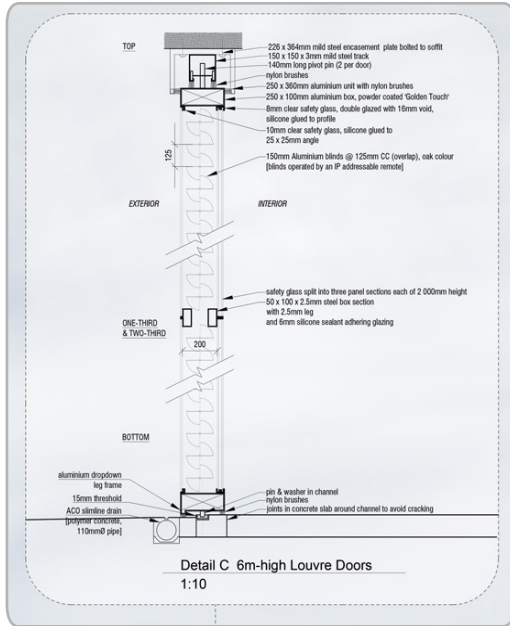

## 4.15 Models & Presentation

---



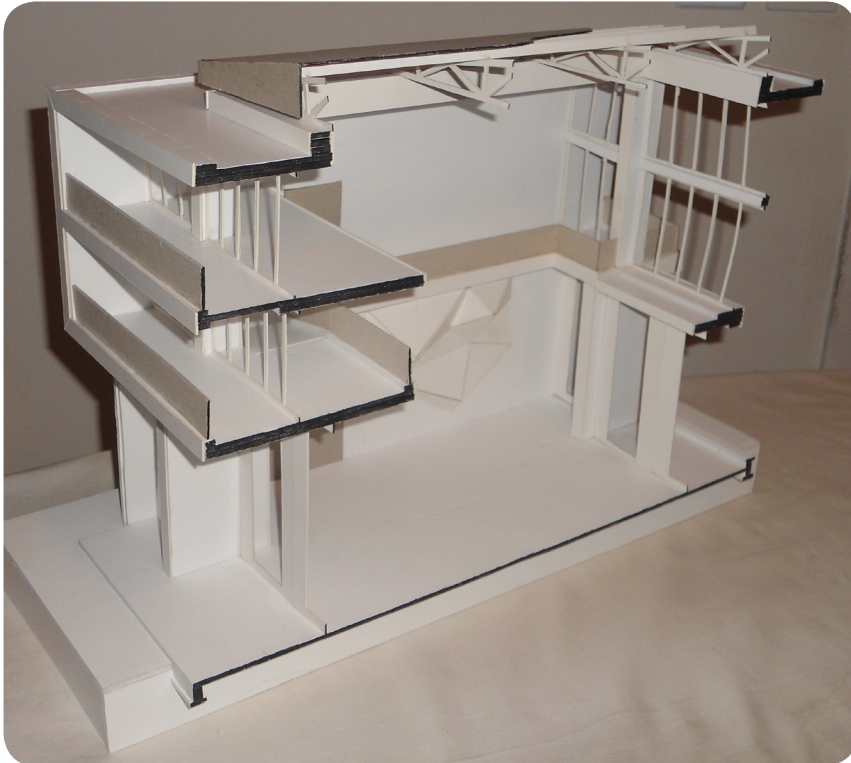

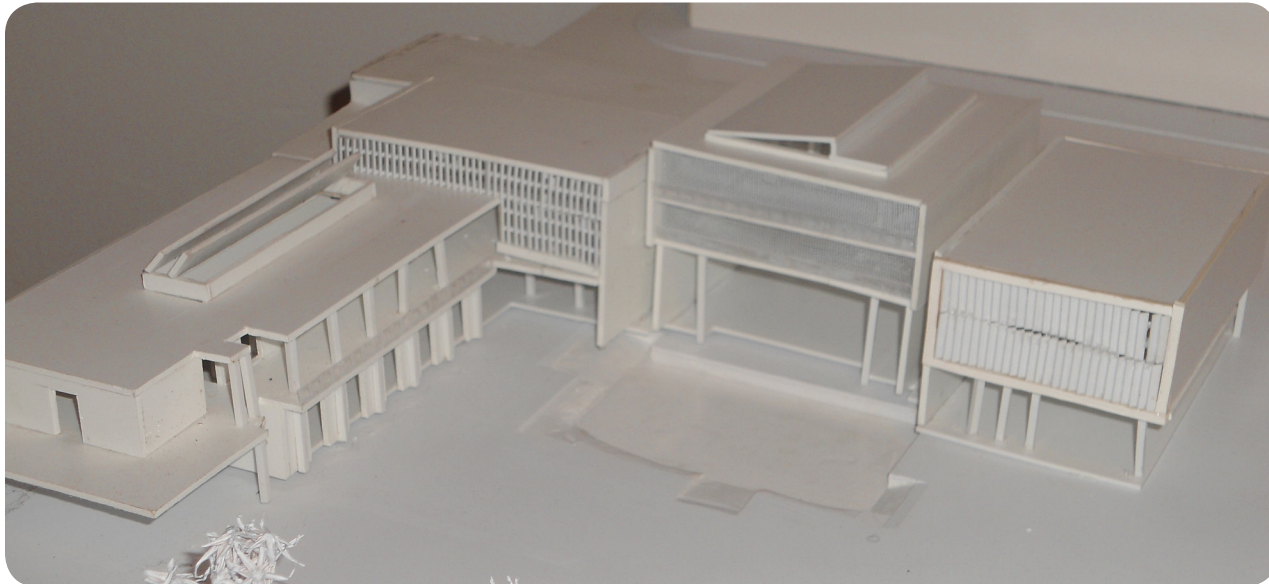
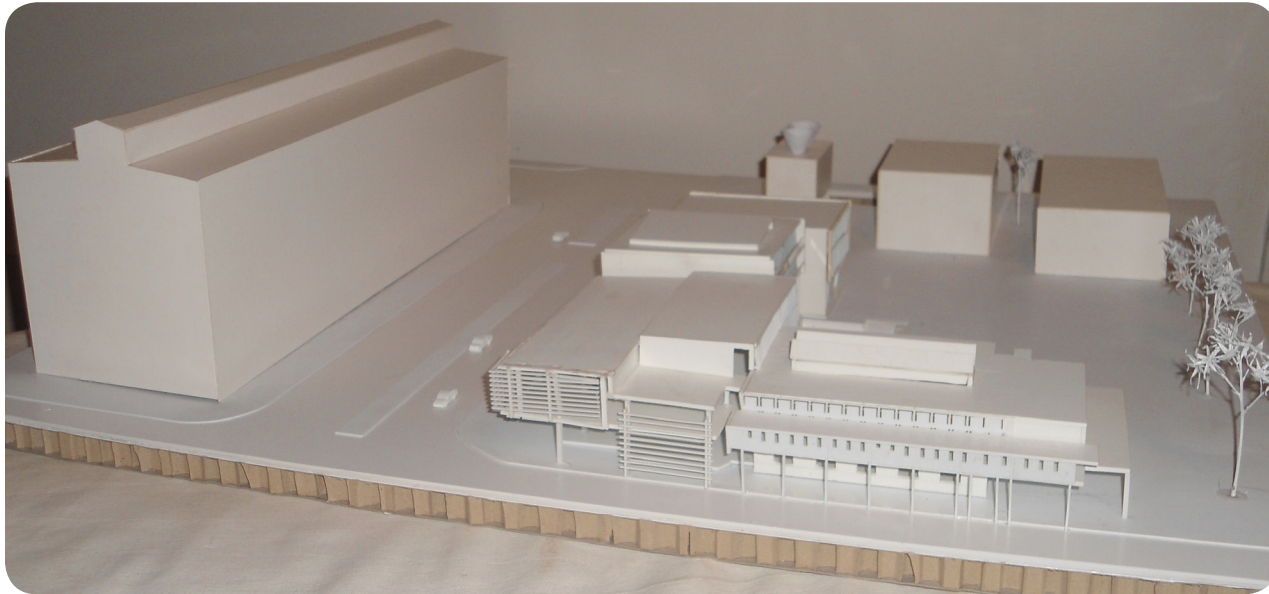



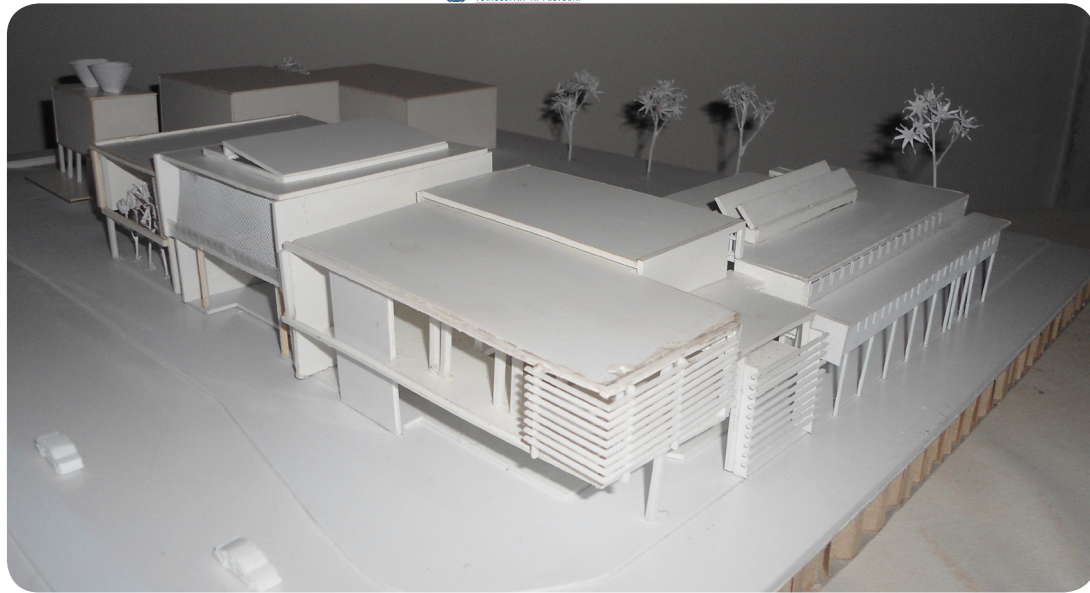

concl

■ 004 experience

vision

# 01 end or beginning

# Conclusion

---

This dissertation set out to explore how architecture should relate to expressing a creative programmatic agenda. The exploration concluded that in the chosen site's particular setting, in terms of its user group, the envisioned programme and the rich cultural heritage of the area, it was best for the built form to be simple in nature in order to let the programme express itself. The outcome is therefore one of a quiet architecture that steps back from extravagant expressions. The architecture allows the community to add their own agenda to the spaces of differing sizes so that the Centre can be truly responsive to the changing needs of the creative community from the area and greater context.

*The following points highlight the dissertation's main concerns:*

## *Form vs Programme* Blank Canvas Architecture

Through exploration, it became apparent that the architecture needed to be secondary to the ability for the creative activity programme

to express itself. The architectural design thus provides spaces of varying sizes and natures that the users can appropriate for their own creative practices.

## *Theory* *Gesamtkunstwerk*

The theory of *Gesamtkunstwerk* played a strong role in conceptualising the dissertation's design and technology as a cluster of differing components linked through the programme, design and technical systems and a finite material palette to combine in order to create a greater whole.

## *Urban Analysis* Routes

Current pedestrian routes were analysed to be an important component in activating the site due to the large number of pedestrian commuters. The site massing channels pedestrians in order to arouse their curiosity of the Centre's activities such that they are drawn into the programme and the creative agenda infiltrates the city to a deeper degree.

## *Site Analysis* Urban Art Community

The notion of strengthening the area's creative visual arts community by providing a place in which they can foster their communal and individual creative identities was key from the onset of the dissertation's precinct analysis. This leads to the incorporation of a central courtyard in the design.

## *Response* Main Courtyard

The central courtyard is seen as the heart of the design, relating to *Gesamtkunstwerk* in uniting the entire collection of architectural parts around its void. It is also key programmatically in terms of offering a fluid space for instillations, both curated and spontaneous. It is the heart that draws all the pedestrian routes together, while offering a place for visitors to casually congregate and exchange their views. This is where the real creative exchange happens.

---

### *Programmatic Response* Transparency

The entire Centre becomes a family of buildings looking onto the courtyard. Transparency is an important element in such a public building that wishes to spread its creative philosophy. The building structure is articulated by its infill being kept transparent to allow passers by to become intrigued by and join in the Centre's activities.

### *Technification* Artisan Aesthetic Contribution

The concept of the area's artisans adding to the design and production of building elements was taken through the technification, tertiary structure and detailing responses. Incorporating the local artisans in the process is important in order to make sure the local community claims the building as their own, as well as providing the artisans with an outlet to advertise their skills while giving employment. The building will act as a reflection of the area's creative practices and larger urban community once claimed by the community and users further afield.

In conclusion, a meandering journey of discovery was experienced through the dissertation's explorations. Design skills were honed while the process is one that taught immensely profound lessons, invaluable to all future endeavors. It was a process that aimed to explore creativity and architecture's relation to creativity, but that was just the beginning.

## Sources

---

### Books:

ALEXANDER, C., ISHIKAWA, S. & SILVERSTEIN, M. 1977. *A Pattern Language*. New York: Oxford University Press.

BARNETTE, J. 1982. *An Introduction to Urban Design*. London: Harper Collins Publishers.

BERNSTEIN, A. [ed] 2002. *Johannesburg, Africa's World City: A challenge to Action*. Johannesburg: Centre for Development and Enterprise.

CHING, F. D. K. 2007. *Architecture: Form, Space, & Order*. Third Edition. Hoboken: John Wiley.

CHIPKIN, C. 1993. *Johannesburg Style: Architecture & Society 1880s-1960s*. Cape Town: David Phillip.

FINGER, A. & FOLLETT, D. [eds] 2011. *The Aesthetics of the Total Artwork: On orders and Fragments*. Baltimore: The Johns Hopkins University Press.

HYDE, L. 2007. *The Gift: Creativity and the Artist in the Modern World*. Second Edition. New York: Vintage Books.

JERVIS, K. & TOBIER, A. [eds] 1988. *Education for democracy: proceedings from the Cambridge School Conference on Progressive Education, October, 1987*. Cambridge School: Weston

JOHNSON, P.A. 1994. *The Theory of Architecture: Concepts, Themes and Practises*. New York: Van Nostrand Reinhold.

OTS, E. 2011. *Decoding Theoryspeak: An illustrated guide to architectural theory*. London: Routledge.

PEARSALL, J. 1999. *The Concise Oxford Dictionary*, Tenth Edition. New York: Oxford University Press.

SCHILPP, P.A. [ed] 1949. *Albert Einstein: Philosopher-Scientist*. New York: Tudor Publishers.

SHAW, G.B. 1921. *Back to Methuselah*. New York: Brentano's.

SNYDERS, M. 2011. *Stich: A Facility in Pretoria East*. MArch(Prof) dissertation, University of Pretoria.

VIERECK, G.S. 1930. *Glimpses of the Great*. New York: Macauley.

---

## Articles:

BLUNDELL JONES, P. 2004. Delight. Architectural Review, 215(1284):98.

COCHRANE, D. 2005. 3 for 2...£1 a scoop. Architectural Review, 218(1305):44-53.

COHN, D. 2006. EMBT daubs an innovative urban-renewal strategy with a highspirited riot of color [sic] in Barcelona's Santa Caterina Market. Architectural Record, 194(2):98-105.

DU PLESSIS, C. 2004. Pursuing the outer limits: a think piece for the day after tomorrow. Sustainable Building 2004: 5th International Conference on Sustainable Building, 13-18 September 2004, Stellenbosch, Paper SB060. Retrieved March 13th, 2010 from [http://www.sustainablesettlement.co.za/event/SBE2004/accepted\\_papers.html](http://www.sustainablesettlement.co.za/event/SBE2004/accepted_papers.html).

FINCH, P. 2005. Market Renewal. Architectural Review, 218(1305):80-83.

GAPP ARCHITECTS & URBAN DESIGNERS. 2001. Newtown Cultural Precinct Urban Design Plan. Unpublished.

ROSENBERG, L. 2008. A study of Durban's backyard: Currie's Fountain. Architecture S.A., 1(2):28-31.

SLESSOR, C. 2005 Market Forces in Architectural Review, 218(1305):44-53.

Victoria Street Market, Durban. 1990. Architect and Builder, 1990(5):14-17.

## Internet:

Department of Arts and Culture [DAC]. 2012. The Department of Arts and Culture, South Africa. Internet: [www.dac.gov.za](http://www.dac.gov.za). Access: 23 February 2012.

IBM. 2010. IBM Global CEO Study. Internet: <http://www-935.ibm.com/services/us/ceo/ceostudy2010/index.html>. Access: 23 February 2012.

Newtown Heritage Trail. 2010 NHT. Internet: <http://www.newtown.co.za/heritage/>. Access: 02 May 2012.



## Figure Sources

---

### Interviews:

ASCROFT, C. Interior Architect, Play Braamfontein. 2012. Interview by author. [Transcript]. February 2012. Johannesburg.

DU PREEZ, J. Psychologist, Tools of Greatness. 2012. Interview by author. [Transcript]. February 2012. Pretoria.

MOYO, M. Headmaster Phoenix College, Happiness House, Park Station Precinct. Interview by author. [Transcript]. February 2012. Johannesburg.

FLEMING [Author] Newtown Park Users - discussion - May 2012.

### Lectures

DE VRIES, F. 2010. Architecture ZA Conference Presented to Architectural Professionals.

RICH, P. 2009. Public Lecture to the Pretoria Institute of Architects.

### Books:

ADAM, J., HAUSMANN, K. & JUTTNER, F. 2004. Industrial Buildings: A Design Manual. Berlin: Birkhauser.

DECKLER, T., GRAUPNER, A. & RASMUS, H. 2006. Contemporary South African Architecture in a Landscape of Transition. Cape Town: Double Storey Books.

FLETCHER, A. 2001. The Art of Looking Sideways. London: Phaidon Press.

HOLLINGSWORTH, M. 1988. Architecture of the 20th Century. London: Bison Books.

KRIGE, S. & BROWN, M. 2005. Finding the Footprints of the Newtown Electrical Precinct Initial Schematic Diagram, Report, Johannesburg.

KRUGER, L. 2011. Metapolis : virtual reality vs. real virtuality in a digital art pavillion, MArch(Prof) dissertation, University of Pretoria.

LAW-VIJOEN, B. 2008. Light on a Hill: Building the Constitutional Court of South Africa. Johannesburg: David Krut Publishers.

---

NASPLE, J. (ed). 2004. Japanese Design. Spain: daab.

#### Articles:

GROBLER, L.J. 2002. Energy Use in Buildings: A Strategy to Reduce Their Usage. In Irurah, D. K. Sustained Building and Integrated Design: 09 – 14 September 2002, p 15. South Africa: IEA

MAGGS, D. 2010. Architecture South Africa: Journal of the South African Institute of Architects, 53(02): cover.

#### Internet:

ACO. 2013. Aco Drain. Internet: <http://www.acousa.com/drain/>. Access 30 September 2013.

ARM. [Sa]. National Museum of Australia. Internet: [http://www.a-r-m.com.au/projects\\_NMoA.html](http://www.a-r-m.com.au/projects_NMoA.html). Access: 02 October 2012.

COLOSSAL. 2012. Art and Visual Ingenuity Internet: <http://www.thisiscolossal.com/>. Access: 15 May 2012.

GOOGLE EARTH. 2012. Internet: <http://www.google.com/earth/index.html>. Access: 10 October 2012.

HAUSER & WIRTH. 2012. Works. Internet: [http://m.hauserwirth.com/artists/3/christophbuchel/images-clips/?view\\_type=list](http://m.hauserwirth.com/artists/3/christophbuchel/images-clips/?view_type=list). Access: 21 September 2012.

Il MERZbau di Kurt Schwitters. 2012. Internet: <http://www.merzbaurekonstruktion.com/ita/merzbau.html>. Access: 15 May 2012.

LABORAATORIO. 2012. Bruno Taut. Internet: [http://www.laboratorio1.unict.it/2008/lezioni/14\\_kahn/pagine/2.htm](http://www.laboratorio1.unict.it/2008/lezioni/14_kahn/pagine/2.htm). Access: 21 September 2012.

LONDON, S. 2012. Burning Man 2012. Internet: <http://www.scottlondon.com/photo/burningman2012/index.html>. Access: 15 May 2012.

METROPOLITAN MUSEUM OF ART. 2012. Heilbrunn Timeline of Art History. Internet: <http://www.metmuseum.org/toah/work-sof-art/1999.363.63>. Access: 21 September 2012.

MIRZA, S. 2012. A Night at the Museum. Internet: <http://theuncommonofcommon.com>. Access: 19 September 2013.

NEWTOWN HERITAGE TRAIL. 2010. NHT. Internet: <http://newtown.co.za/heritage/>. Access: 19 March 2012.

PAINTINGS. 2012. Leonardo da Vinci. Internet: <http://paintings-art-picture.com/paintings/archives/1475/leonardo-da-vinci-paintings-scythed-chariot>. Access: 12 April 2012.

OWEN LEWIS, J. 1999. A Green Vitruvius: Principles and Practice of Sustainable Architectural Design. London: James & James Ltd.

REIDSTEEL. 2013. Hangar Doors. Internet: <http://www.hangardoors.com/>. Access: 25 September 2013.

SANBI. 2006. Plant ZA. Internet: <http://www.plantzafrica.com/>. Access: 29 September 2013.

TREVISI INFORMATION. 2012. The Pescheria. Internet: <http://www.trevisoinfo.com/fishmarket.htm>. Access: 09 August 2012.

UNI-SPAN. 2013. Formwork and Scaffolding. Internet: <http://www.uni-span.co.za/coffer-sandtroughs.html>. Access: 25 September 2013.

# List of Figures

---

Figure 1: The addition of a missing layer to Newtown’s Electric Power Station Heritage Precinct	5
Figure 2: Kolb’s Methods of Learning:   reflection   theorisation   experimentation   experiencing   [Author, 2012]	12
Figure 3: Increased speed of technological progression [Author adaptation from Kruger, 2011]	17
Figure 4: The aerial view of a secure estate in the suburb of Fourways, Johannesburg, South Africa. Such an image aptly illustrate the loss of identity and cultural heritage in portions of contemporary society [Google Earth, 2012]	18
Figure 5: Leonardo da Vinci’s polymath workings	19
Figure 6: Phoenix College Principle Moyo states that parents of the Semi-Private school are not interested in cultural education for their children as it is not seen to help them become University-trained Professionals [Author, 2012]	19
Figure 7: Imagination can lead individuals to change their circumstances [Fletcher, 2001]	20
Figure 8: ‘Imagination is everything’ - Albert Einstein [in Viereck, 1930:372] [Fletcher, 2001]	21
Figure 9: ‘Everything you can imagine is real’ - Pablo Picasso: Imagination’s ability to transform circumstance [Ryal, 2010]	22
Figure 10: The differences between utilising one’s imagination versus being a sponge to generic societal chatter are pronounced [Author, 2012]	23
Figure 11: ‘Shack Rise’ by Daniel Maggs illustrates an underprivileged community creatively and organically adapting an abandoned structural frame for their own means: “celebrating the potential of the human and creative spirit. It stands in counterpoint to the subsidised wastelands the South African Government is building for the poor and the endless tracts of bland, middle-class suburbia” [Cooke, 2012].	25
Figure 12: The programmatic precedence of the week-long Burning Man festival in Nevada’s Black Rock Desert, United States of America. The annual festival can be seen as the ultimate expression of radical creative practice; where a community fully engages in bringing each individual’s talents to the communal pool to generate a more profound output through their collective engagement [London, 2012]	27
Figure 13: Dot Appropriation Room [Colossal, 2012]	29
Figure 14: Experimentation Centre activities [Colossal, 2012]	30
Figure 15: Experiential Installations in the Hall [Colossal, 2012]	31
Figure 16: Instillations in the Hall and Linking Spaces [Colossal, 2012]	32
Figure 17: External Landscaping [Colossal, 2012]	32
Figure 18: Served and Servant Spacial Zones for the site. Pink areas house Cafe Kitchens, vertical circulation and toilets, while orange areas house horizontal servicing corridors or riser ducts. The service areas divide the programmatic areas into Zones A to D in the main building [Author, 2013]	36
Figure 20: FNB’s logo; involvement & sponsorship of Art; Inner City National Head Office	40
Figure 19: BASA’s logo; mission; involvement in Art	40
Figure 21: Figure 19: Programmatic Target User Group [Author, 2012]	41

---

Figure 22: The relevance of architecture to the imagining and creative idea realisation [Author, 2012] .....	44
Figure 23: The site of the proposed project is located in Africa: South Africa: Gauteng Province: Johannesburg Inner City: The Cultural Arc: Newtown Precinct: North East Corner of the EPSHP [Author, 2012] .....	45
Figure 24: Adapted Inner City mapping from JDA Maps 2009 - to gain an understanding of general city principles, regions and facilities. The extent of the population living in the North East sector of the city is highlighted; along with the lack of community facilities [Author, 2012] .....	47
Figure 25: Cultural Arc Nodes: Energy and Investment [Author, 2012] .....	49
Figure 26: Greater Newtown Key Features [Author, 2012] .....	51
Figure 27: Newtown Precinct - Map of Key Features [Author, 2012] .....	55
Figure 28: Historic Newtown Photographs [NHT, 2010] .....	55
Figure 29: First & second left: Historic Newtown photographs [NHT, 2010] .....	58
Figure 30: Below opposite: 2001 Bus Factory Renewal [Author, 2012] .....	58
Figure 31: Right & left: Contemporary Newtown [Author, 2012] .....	58
Figure 32: Below middle - left: Brickfields [Deckler <i>et al</i> , 2006; Author 2012] .....	58
Figure 33: The Newtown Electric Power Station Heritage Precinct [Author, 2012] .....	59
Figure 34: (far right) The historical nature of the Electrical Heritage Precinct: Photograph of The Electrical and Transportation Precinct showing the site's cooling towers in 1957 [Adjusted from Krige, 2005] .....	65
Figure 35: (top right) Plan of said photograph [Adjusted from Krige, 2005] ..	65
Figure 36: (bottom right) Site Plan from 1980 showing the historical structures [Adjusted from Krige, 2005] .....	65
Figure 37: The site, looking North; showing the elevated base of the remaining lone concrete cooling tower [Author, 2012] .....	67
Figure 38: Looking East towards Turbine Hall [Author 2012] .....	68
Figure 39: Plan and photographs of Existing Site Elements [Author 2013] .....	69
Figure 40: Mapping users profiles and patterns around the precinct [Author, 2012] .....	71
Figure 41: Pedestrian movement routes proliferate through the precinct and map the rhythms of users [Author, 2012] .....	73
Figure 42: Newtown users show a profound interest in the arts and cultural pursuits [Author, 2012] .....	74
Figure 43: Daily processes in the Newtown Electric Power Station Heritage Precinct [Author, 2012] .....	75
Figure 44: Land Ownership [Author, 2012] .....	76
Figure 45: Preliminary Urban Response Diagrams [Author, 2013] .....	78
Figure 46: The Proposed Framework Diagram [Author, 2012] .....	79

---

Figure 47: Understanding the former processes in the Cooling Tower [Author, 2013] .....	81
Figure 48: Former, Present and Proposed Uses of the Cooling Tower [Author, 2013] .....	82
Figure 49: Model of Urban Response [Author, 2013] .....	83
Figure 50: Architectural Response: Creating a Network of Learning [Author, 2012] .....	85
Figure 51: Fragmentation: <i>Gesamtkunstwerk</i> , seen as ‘the total artwork’, where a collection of parts are bound to one another to form a unified whole. Each singular part is seen to reference another ‘system’ with the combination of such disjointed assemblies creating a richer end product [Author, 2012] .....	93
Figure 52: Entrance to Buchel’s Dump instillation. Safety helmets are mandatory; with a maximum of two visitors entering simultaneously [Hauser & Wirth, 2012] .....	96
Figure 53: Dada Artist Jean Arp: Squares Arranged According to the Laws of Chance [1917; cut and pasted papers, ink and bronze paint][MOMA, 2012] ....	97
Figure 54: Bruno Taut: <i>Die Stadtkrone</i> [The Crown of the City], 1919, depicts the new era of spiritual enlightenment orchestrated by the new architectural agenda [Laboratorio, 2012].....	101
Figure 55: Erich Mendelsohn: Einstein Tower, Potsdam-Berlin, 1919-22, illustrating the new architecture of the Expressionist Architects embodying a new spirituality [Hollingsworth, 1988] .....	102
Figure 56: Pablo Picasso: Still Life with a Bottle of Rum [1911, Oil on canvas] displays fragmented facets combining to create a greater, over-all holistic, united composition [MET, 2012] .....	103
Figure 58: A Bauhaus teapot design demonstrates the new preoccupation for all Architectural project components to be designed - from the macro to micro scale [Hollingsworth, 1988] .....	104
Figure 57: The Reitveld Chair [1918] by Gerrit Reitveld is seen to reduce the chair form to its pure functional essence, for a new architectural vocabulary typical of the concerns of the De Stijl movement [Hollingsworth, 1988] .....	104
Figure 59: [left] Kurt Schwitters’ Merzbau constructions made from fragments left by the First World War [II MERZbau, 2012] .....	105
Figure 64: Garden of Australian Dreams: courtyard at the heart of the facility [Author, 2003] .....	112
Figure 65:[above] Combination of components relating to <i>Gesamtkunstwerk</i> [ARM, 2012] .....	112
Figure 66: Expressive entrance route canopy known as ‘The Uluru Axis’ due to its alignment with the Uluru Rock national landmark [Author, 2003] .....	112
Figure 60:[left] Aerial view of the Museum layout forming a new waterfront at the end of Canberra’s Acton Peninsula [ARM, 2012] .....	112
Figure 61:[below centre] Details of historically relevant wording incorporated into the walkway surface finish [ARM, 2012] .....	112
Figure 62:[below right] The articulated mix of materials, include braille-worded anodised aluminium panels [Author, 2003] .....	112
Figure 67: Interior Entrance Foyer. The form is derived from the shape of a knot; with the built form occupying the negative space [Author, 2003] .....	112
Figure 63:[below] Interior Theatre [ARM, 2012] .....	112
Figure 69: Parti-diagram illustrating the essence of the design concept through fragments relating to one another to create a united offering [Author, 2012] ..	116

---

Figure 68: Different layouts of clustered organisations [Ching, 2007]	116
Figure 70: Diagram relating the stages of Kolb's Modes of Learning [Author, 2012]	117
Figure 71: Central Pole Garden for appropriation [Author, 2012]	118
Figure 72: Model of reserved building relating to Newtown's industrial heritage [Author, 2012]	119
Figure 73: Porter's Market, Tokai Forest, Cape Town, South Africa: conveys a holistic market atmosphere [Author, 2010]	122
Figure 74: Original Cohn [2006] graphics of the Santa Caterina Market manipulated by Author [2012]	127
Figure 75: Historic Depictions of The Treviso Fish Market [top left]; along with its contemporary atmosphere and renewed structures [Blundell Jones, 2004; Treviso Information, 2012]	130
Figure 76: The sensual feast at the weekly Durban Market [Author, 2012]	131
Figure 77: Sketch of The Imagination Station according to the Market typology exploration [Author, 2012]	132
Figure 79: Sketch of Imagination Station Ground Floor [Author, 2012]	133
Figure 78: Sketch model development [Author, 2012]	133
Figure 80: Sketch of Design Journey Evolution [Author, 2012]	134
Figure 81: Sketch model development: experimenting with facade and corner articulation [Author, 2012]	135
Figure 82: Drawings [Author, 2012]	136
Figure 85:(left) Zone Diagram [Author, 2013]	147
Figure 84:(below) The importance of connection [Author, 2013]	147
Figure 83:(right) Birds-eye view looking North over the Centre from the South [Author, 2013]	147
Figure 86: Northern facade fronting Jeppe Street [Author, 2013]	149
Figure 87: Site Plan [Author, 2013]	150
Figure 91:(far left) Ground Floor Plan [Author, 2013]	152
Figure 89:(left) First Floor Plan	152
Figure 90:[Author, 2013]	152
Figure 88:(below) Restaurant Mezzanine Floor Plan [Author, 2013]	152
Figure 92: Enlarged view of Ground Floor Plan - Zone A & B [Author, 2013]	153
Figure 93: Enlarged view of First Floor Plan - Zone A & B [Author, 2013]	154
Figure 94: Enlarged view of Ground Floor Plan - Zone C & D [Author, 2013]	155
Figure 95: Enlarged view of First Floor Plan - Zone C & D [Author, 2013]	156
Figure 96: <i>Phase 1</i> Portion of the <i>Shared Super Basement</i> between the Imagination Station and Sci-Bono [Author, 2013]	158

---

Figure 98:(left) North Elevation [Author, 2013] .....	160
Figure 97:(below) Artist's South Elevation [Author, 2013] .....	160
Figure 100:(left) East Elevation [Author, 2013] .....	162
Figure 99:(below) Section BB [Author, 2013] .....	162
Figure 101: Section AA through Idea Interchange, Courtyard and Exhibition Hall [Author, 2013] .....	163
Figure 102: (right) Expressing the workings of components to encourage learning [Author, 2013] .....	169
Figure 103:(top right) Zone Diagram [Author, 2013] .....	169
Figure 104:(top) Paved gradient falling towards the Centre Pompidou [Mirza ,2012 :(online)] .....	171
Figure 105:(middle) Coloured slats create a lively atmosphere in The SEED [AOJ, 2013:(online)] .....	171
Figure 106:(bottom) Inspiration for hall volume and glazed facade treatment of a 'box' structure [Adam <i>et al</i> , 2004].....	171
Figure 107:(far right) Technical elements of the WAM include the openable Ground Floor Plan; WAM's glazed Ground Floor Facade is open to appropriation, as seen with the digital display viewed from the street; while the interior Lobby is seen to be able to cater to a range of events [WAM, 2013:(online)] .....	171
Figure 108:(opposite page from top left) <i>Materiality, Finishes, Textures &amp; Tones</i> : texture and appropriation of off-shutter concrete [Nasple, 2004]; power floated floor finishes, with oxide additives for spatial differentiation; the soft visual texture of bamboo as the walls and flooring of the Idea Interchange Capsules [Trade brochures, 2013; craft aesthetic in metal screens as tertiary palette [Author, 2012]; acid washed steel in finishes such as concrete slab edging strips; neutral colour tones offset by colour highlights to accentuate key areas; copper detailing; fritted glass for patterned sun control [Trade brochures, 2013]; precedent of hanger doors for large openings [ReidSteel, 2013] .....	173
Figure 109: Newtown's historic buildings (right column) compared to their contemporary counterparts (far right column) [Author, 2012] .....	173
Figure 110: First Floor coffer slab layout for Zone B - Foyer - showing double volumes and vertical service penetrations [Author, 2013] .....	175
Figure 111: Zone B coffer slab lighting appropriation [Uni-span, 2013].....	176
Figure 112: Zone C - Hall - Structural Sketch and Exploration with Structural Engineer [Author, 2013].....	176
Figure 113: (full spread) Zone C - Hall - Structural Sketch; Model and Engineer's member size calculations [Author, 2013] .....	177
Figure 114: Break down of the components comprising a building's energy consumption [Grobler, 2002:15] .....	179
Figure 115: Zone A - Passive Lighting Strategies [Author, 2013].....	181
Figure 116:(above) Looking at the effects of double glazing with reference to the Hall's glazed doors facing West [Owen Lewis, 1999]; Craft aesthetic for louvres as shown at The Constitutional Court [Law-Viljoen, 2008]; Concept of adjustable louvres inside the Hall's doors [Author, 2013]; Detail of 6m high double glazed doors with internal louvres [Author, 2013] .....	182

---

Figure 117: Passive air flow strategies through the Hall (Diagram Section AA); Artist's Studios (Diagram Section CC) and Reception (Diagram Section EE) [Author, 2013] .....	183
Figure 118: Schematic plans of passive ventilation systems [Author, 2013] .....	184
Figure 119: (top left) Sketches exploring devices and systems for passive ventilation, cooling and heating; (top right & bottom) Plan and section showing spatial definition through planting [Author, 2013] .....	185
Figure 120: (anti-clockwise from top left) <i>Craibia zimmermannii</i> for the larger courtyard defining border; <i>Dais continifolia L.</i> for the smaller courtyard trees offering unique pompom clustered blossoms in Summer; Tree Wisteria as a smaller courtyard tree; <i>Ficus Benjamina</i> , indigenous, but one of the few trees able to be grown indoors; Dwarf Mondo grass, indigenous, but requires minimal maintenance and creates a pleasing aesthetic between paving [SANBI, 2006] .....	186
Figure 122: Circa Gallery Precedent by StudioMAS Architects [Author, 2011] .....	187
Figure 123: Circular motifs portray a vibrant atmosphere [Trade brochures, 2013] .....	187
Figure 121: Aco Drain components [Acodrain, 2013].....	187
Figure 124: Lighting to be set against the steel box framework and in the suspended bubbles.....	188
Figure 125: Exploration of Acoustic Wall Baffles for the Hall as seen in Section AA [Author, 2013] .....	189