

THE EFFECT OF PEDAL BIOMECHANICS ON THE VENTILATORY THRESHOLD, VO₂ -MAX AND MOTION ECONOMY OF CYCLISTS

CHAPTER 1

THE PROBLEM

1.1 INTRODUCTION

Cycling is, in all its most popular forms, an endurance sport *par excellence* (Burkett & Darst, 1987; Van der Plas, 1989; Timmer, 1991; Fu & Stone, 1994). Whether a person's goal is basic fitness levels, rehabilitation (Schwartz et al., 1991), recreational events or competitive sport, cycling can play a primary and secondary role in achieving that goal (Drory et al., 1990; McArdle et al., 1991; Schwartz et al., 1991; Timmer, 1991; Eisner et al., 1998). One hundred kilometer rides and even multiples of these distances are so popular and common that all of them cannot even be listed by the cycling publications each week (Beneke et al., 1989; Van der Plas, 1989). Cape Town's Argus Tour had its beginnings in 1978 when 550 riders participated in this event. By 1989 the number of riders had increased to up to 12 000 (Beneke et al., 1989). In the 1999 Cape Argus Pick 'n Pay Cycle Tour, 35 000 cyclists started the cycling event from Hertzog Boulevard around Fish Hoek, Cape Point and Chapmans Peak (Di Loughton, 1999). The winning time for this 105km race was 2.31.26 by Jaques Fullard from Pretoria (Di Loughton, 1999). There is not a more suitable way to achieve basic fitness than cycling (Van der Plas, 1989; Fox et al, 1993). The bicycle is a triumph of simplicity and efficiency: relative to its mass, nothing else can move further or faster for the amount of energy consumed (Beneke et al., 1989).

Apart from the social event, cycling has also climbed the ladder in competitive sport. No matter how fit, unfit, strong or weak a person is, there lurks within all of us a competitive streak, a will to win.

This compulsion to test one's abilities against those of others is inherent in human nature (Rushall & Potgieter, 1987; Beneke et al., 1989). When bicycles were invented, one of the first things people wanted to do, was to go faster than anyone else. This obsession with speed and competition has been with cyclists ever since (Beneke et al., 1989; Burke, 1986). The role of science in cycling has grown over the years as more cyclists search for a competitive edge based on something more than tradition or guesswork (Burke, 1986). However, various factors have been identified that influence cycling performance, involving maximal oxygen consumption, lactate or ventilatory threshold, economy of movement, body composition, muscle fibre type and years of cycling experience (Kyle & Burke, 1984; Krebs et al., 1986; Brandon & Boileau, 1987; Coyle et al., 1988; Brandon & Boileau, 1992).

The bicycle is also an excellent way to attain cardiovascular fitness and muscle endurance without putting a lot of strain on the hips and legs (Burkett & Darst, 1987; McArdle et al, 1991;). In running, your legs are subjected to forces up to five times your body weight. Cycling does not produce nearly these forces generated by running, because the bicycle is supporting the body weight (Burkett & Darst, 1987). Cycling can be used as a recreation and social activity for friends and family to spend time together. Mountain bike rides are taken to explore some of the wilderness areas of Southern Africa (Beneke et al, 1989; Van der Plas, 1989). At a given sub-maximal load it demands about the same mechanical efficiency despite the cyclist's age and fitness level and the efficiency is not dependant on body weight (Mandroukas, 1990). According to Burkett & Darst (1987), cycling can be a great life time activity that can be fun for all people regardless of their physical ability and age. It can also be a husband and wife activity to spend some time together and get away from the children for a short while.

The well-known cycle pedal mechanism, as everybody knows it, has been unquestionably accepted and unsuccessfully challenged for many decades. Any improvement, however marginal it may be, will in all probability affect the cycling community worldwide.

Pedals are the vital link between your body and the bicycle (Pierson- Carey et al., 1997). The way you tend to turn them determines to a very great degree the efficiency with which you ride (Burke, 1986; Beneke et al., 1989; Mandroukas, 1990). Efficient pedalling is a smooth, rotary action and never a broken up-and-down movement. Toe-clips or clip-less pedals are essential for this. They enable you to take weight of the pedals on the upstroke of the pedalling circle, and to pull them up instead of simply pushing on the down stroke (Burke, 1986; Beneke et al., 1989; Timmer, 1991). Research done by Davis & Hull (1981), reported that the effectiveness of pedal forces increased with the use of toe-clips. The advantages of a smooth pedal action are that it reduces the likelihood of saddle soreness and it helps to prevent general muscle and body fatigue (Beneke et al., 1989; Fu & Stone, 1994). It is also very important to achieve good cadence. The cadence refers to the speed with which the pedals are turned. For recreational riders, a comfortable cadence is between 60 and 85 revolutions per minute (Ericson & Nisell, 1988; Beneke et al., 1989; Patterson & Moreno, 1989). Though, according to Mandroukas (1990) there is disagreement as to the optimal pedalling cadence.

The oxygen consumption, power output and mechanical efficiency during cycling is affected by different parameters such as workload, saddle height and pedalling rate. By changing these parameters in a controlled and desired way we can minimize the oxygen consumption and increase the mechanical efficiency of cycling (Nordeen-Snyder, 1977; Ericson & Nisell, 1988; Patterson & Moreno, 1989; Barnett et al., 1996).

The development of an ideal crank drive for bicycles does not focus on creating a drive that is optimal with respect to biomechanics alone. Rather, a new drive should allow optimal adaptation to the biological system of the human body (Burke, 1986; Power Pedal I, 1993). Empirical measurements have shown that cyclists apply the largest forces in the area of 135 degrees past 'top dead centre' (TDC). This is due to muscle-physiological reasons. In cycling, the goal is to produce maximal torque in the biologically favourable working regions of the muscle system (Burke, 1986; Ericson & Nisell, 1988; Power Pedal I, 1993).

More research needs to be done to determine in which way, by changing the crank drive lever arm, the athlete can optimize his VO_2 and economical movement. This will help the athlete to improve his speed and endurance of cycling in the most economic way, in terms of low energy consumption (VO_2) and a higher ventilatory threshold (Mandroukas, 1990; Heil et al., 1997).

1.2 PROBLEM SETTING

Theories abound as to different crank drive lever arms, some of which have been universally accepted. As stated above, it is important for the crank drive to allow bio- mechanical adaptation of the body to the working of the crank lever arm (Burke, 1986). Research done by the STS Power Pedal Corporation (Power Pedal II, 1998) had great success in reducing knee stress during cycling by changing the crank lever arm. They also found that training on these devices improves cardiovascular conditioning as compared to a regular drive system, and it also trains the muscle group correctly (Power Pedal II, 1998).

The law of physics states that the resulting torque, which drives the bicycle is equal to the product of force applied to the pedal times length of the lever arm (Power Pedal III, 1998). According to this theory, an elongated lever arm during the down-stroke, where the greatest torque is produced, will increase power output (Power Pedal III, 1998). In experiments described by Burke (1986), cyclists reported that

they definitely pull up during the recovery phase. This seems contrary to most of the data reported in literature and the general response of elite riders whose data are known. Hoes et al. (1968), Gregor (1976), and Lafortune et al. (1983) all have reported the *absence* of pull-up forces in the recovery phase. Then why, during steady-state riding, do pursuit riders not pull up during the recovery phase? Presumably, the answer lies in the understanding of energy cost of pulling up (Burke, 1986).

This leads to the question whether or not, and to what extent, a variation in the crank biomechanics can influence performance of a competitive cyclist. Would it have an effect on oxygen consumption (VO_2), muscle fatigue, economical movement and the ventilatory threshold?

1.3 HYPOTHESIS

The following hypothesis are related to the purpose of this study:

- a. the ventilatory threshold is higher when making use of a longer crank lever arm during the down -stroke phase; and
- b. the cyclist's movement and energy consumption (VO_2) is more economical when making use of the longer crank lever arm during the down-stroke phase.

1.4 PURPOSE AND AIM OF THE STUDY

The purpose of this study is to determine a way in which the athlete can optimize his oxygen consumption. This will help the athlete to improve his speed and endurance of cycling in the most economic way, in terms of low energy consumption (VO_2) and a higher ventilatory threshold (Patterson & Moreno, 1989; McArdle et al., 1991; Kenny et al., 1995; Buttelli et al., 1996; Hintzy et al., 1999).

In order to find a way to help the athlete improve his performance, the following aspects need to be investigated.

1.4.1 Primary objectives:

- a. To determine whether a variation in the crank lever arm length influences economical movement and the ventilatory threshold of the cyclists.

1.4.2 Secondly:

- a. To determine the bio- mechanical working of the leg action while pedalling and the influence of a different crank lever arm on muscle fatigue.

According to Ericson & Nisell (1988) no investigations have been done on the changes in force efficiency due to different speeds, saddle heights, pedal foot positions and crank lever arms.

CHAPTER 2

LITREATURE REVIEW

This section of the review covers those factors contributing to the cyclist's VO_2 -max, economical movement on the bicycle and other physiological changes occurring during cycling. In this epidemiological study of cycling physiology and biomechanics, it is important to understand all those factors that could influence the output of the research.

2.1 HISTORY AND BACKGROUND

The first bicycles to reach South Africa in any numbers arrived in the 1870's. The ancestors of the bicycle go back to pre-Christian vehicles propelled by hand cranks and to hobby-horses used in medieval revels. Only in the early nineteenth century did the bicycle begin to take shape in the form in which we know it today (Beneke et al., 1989). The role of science has grown over the past decade to give cyclists a more competitive edge (Burke, 1986).

In the decade following the Argus Tour, eight regional Pedal Power Associations have been formed in South Africa with a total of about 20 000 members (Beneke et al, 1989; Power Pedal I, 1993). South Africa's bike boom is only a part of the global source in the demand for pedal power. More than 100 million bicycles are manufactured annually and more people travel by bicycle than any other form of transport (Beneke et al., 1989; Marsh & Martin, 1996).

Another factor has been the vastly improved quality and variety of bicycles and cycling equipment available. You can get anything from a smooth moving, streamline racer to a tough and agile mountain bike. The bike is no longer seen as a backward and painful way of getting about, but as an exhilarating, efficient product

of elegant technology and functional design (Schneider et al., 1989; Capelli et al., 1997).

Scientists have shown that the rider-bicycle combination has a more economical use of energy than any other animal or machine. The New Encyclopedia Britannica describes the bike as 'the most efficient means yet devised to convert human energy into propulsion' (Loftin et al., 1990; Glass et al., 1998).

2.2 TYPES OF BICYCLES

In the early 1960's the only two basic adult bicycles one could buy were the 3-speed and the old standard balloon tyre bicycle. In the late 1960's the 10-speed (racing) dropped handlebar bicycle became popular. In the early 1970's the BMX (moto-cross) became popular with the younger cyclists (Burkett & Darst, 1987). The consumer today has to make a choice between several types of bicycles (Ennis, 1984).

a. The 3-Speed Bicycle

The 3-speed bicycle, also known as the English racer, can take much abuse. The upright riding position is good for vision and you can shift the gears when stopped. The 3-speed bicycle is excellent for short trips, but not the choice for long trips and steep hills. The weight and limited gear selection make it unacceptable for touring and long distances (Burkett & Darst, 1987; Schneider et al., 1989)

b. The Adult Cruiser

The adult cruiser is an excellent alternative to the 3-speed bicycle and is ideal for riding around town for short trips. Cruisers can come with 3-speed hubs with coaster brakes in the back and caliper brakes in front. It can also come with derailleurs and it has caliper brakes on both the front and the rear tyres (Burkett &

Darst, 1987). The adult cruiser is an upright bicycle with balloon wheels. The weight of the cruiser is its biggest problem, though the bicycle has proven reliability and is usually inexpensive to buy (Ennis, 1984; Schneider et al., 1989).

c. The Deraillieur Bicycle (racing bicycle)

The 10-, 12- or 14-speed racing bicycle with dropped handlebars is the most popular bicycle in the United States. It is a light and fragile machine (Van der Plas, 1989). It is an excellent bicycle when used on paved roads for touring and longer distances (Ennis, 1984). It is also a good short trip bicycle and it handles hills very well. The nemesis of a deraillieur bicycle is when used on rough or unpaved roads. The racing bicycle will require much more maintenance and care than the above mentioned ones (Burkett & Darst, 1987; Schneider et al., 1989; Van der Plas, 1989)

d. The Mountain Bicycle

The mountain bicycle is a very strong and rugged bicycle that is a cross between the Cruiser, racing bicycle and the BMX (Burkett & Darst, 1987). Its thick tyres, flat handlebars, powerful brakes and wide- range gearing make it the ideal bike for those people who do not feel immediately at ease on a racing bicycle (Van der Plas, 1987). The handlebars and other components have been designed for strength, ruggedness and durability. The main weakness of the bicycle is that it is not very good for long tours and extended riding. It uses large knobbly tyres and rims where a great part of the weight is found and this is what makes the mountain bicycle “off limits” for longer distances (Burkett et al , 1987; Schneider et al., 1989).

d. The BMX Bicycle (moto-cross)

The BMX is very popular amongst younger people. It can be used for short course dirt track racing, but also for pleasure riding (Burkett & Darst, 1987; Van der Plas, 1987).

2.3 BIOMECHANICS OF CYCLING

In this review we will focus on cycling biomechanics as a way in which the rider applies force to propel the system forward. This has been studied by a number of scientists, starting with Scott (1889), followed by Hoes et al. (1968), Davis & Hull (1981), Daly & Cavanagh (1976), Gregor et al., (1985), and Heil et al., (1997). The importance of studying the way the rider applies force to the cycle and the limb movements accompanying this action will never diminish, regardless of the technical advantages that are made in the field of equipment research and design (Mandroukas, 1990). The rider will still have a number of alternatives in the way that he expends his energy, but research and technology can help the cyclist to optimize his performance (Heil et al., 1997).

Geometric variables on a cycle ergometer dictate the position of the cyclist on a bicycle. The variables include crank length, saddle height, seat-tube angle, trunk angle and leg and foot angles (Heil et al., 1997). Literature makes a distinction between optimal and preferred geometry (Faria & Cavanagh, 1978). *Optimal geometry* can be defined as one that coincides with the minimization of a VO_2 -based cost function measured during sub-maximal exercise. *Preferred geometry* could be defined as one where a cyclist would freely choose if he has a choice (Heil et al., 1997).

2.3.1 Movements of the Legs

When the subject sits on the bicycle, a triangle is formed by:

- a. the thigh: measured from the tip of the greater trochanter to the lateral knee joint line,
- b. the leg: measured from the lateral knee joint line to the plantar aspect of the heel, and
- c. the hip-to-heel distance: measured from the tip of the greater trochanter to the plantar aspect of the heel (Schwartz et al., 1991).

During cycling, it is interesting to identify the mean ranges of motion that the major joints and segments of the leg move through during one revolution of the crank (Burke, 1986; Timmer, 1991).

Hip movement during cycling was reported by Timmer (1991) for the smaller amount of hip flexion to be 28-30° and the greatest amount 90° (Cavanagh & Sanderson, 1986). From 90° onwards, the hip starts to rotate internally and to adduct. Any additional hip flexion would cause an unstable pelvic position due to the small base of support from the seat (Houtz & Fisher, 1959; Timmer, 1991). The thigh (fig. 1a and 1b) moves through an arc of 43° starting at 19° of the horizontal just after **top dead centre (TDC)** to within 28° of the vertical just before **bottom dead centre (BDC)** (Mandrourkas, 1990; Timmer, 1991).

As seen in figure 1c and 1d, the mean range of *motion for the knee* is 74° (Timmer, 1991). The knee is still flexed 37° close to BDC, whereas just before TDC the maximum flexion is 111°. It is important to note that the knee is still considerably flexed at BDC. Maximum force is exerted when the crank is horizontal at 90° angle (Hoes et al., 1968; Burke, 1986; Ericson & Nisell, 1988).

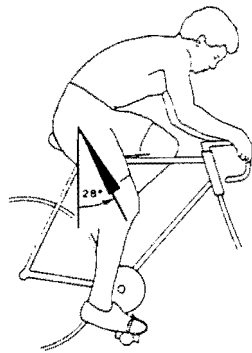

(a)

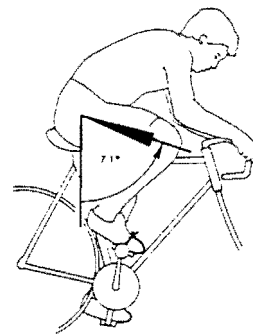

(b)

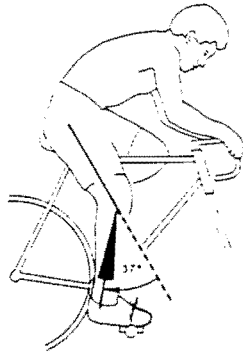

(c)

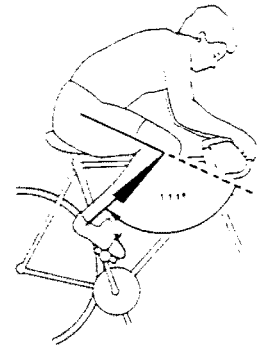

(d)

Figure 1: The position of the body and the crank during different phases of cycling. (a) Minimum hip flexion, (b) maximum hip flexion, (c) maximum knee extension, (d) maximum knee flexion (Timmer, 1991).

During cycling, the knee and the hip joint never reach full extension, although maximal knee and hip extension occur simultaneously (Timmer, 1991).

When looking at *ankle movement*, ankling refers to the orientation of the pedal with respect to a reference frame fixed in the cycle, or the vertical on level ground. Traditionally, the heel should be dropped as the pedal moves through the top of the crank revolution from 30° before TDC to 30° after TDC. The toe should then be dropped across the bottom of the revolution (fig 2a). Research done on elite cyclists show that pedal orientation dips only slightly below the horizontal to a heel-down position (fig 2b). This does not occur across the top of the cycle, but at 90° beyond TDC. The maximum toes-down position actually occurs at 75° before TDC (Burke, 1986; Timmer, 1991). Research done by Davis & Hull (1981) reported that the effectiveness of pedal forces increased with the use of toe-clips.

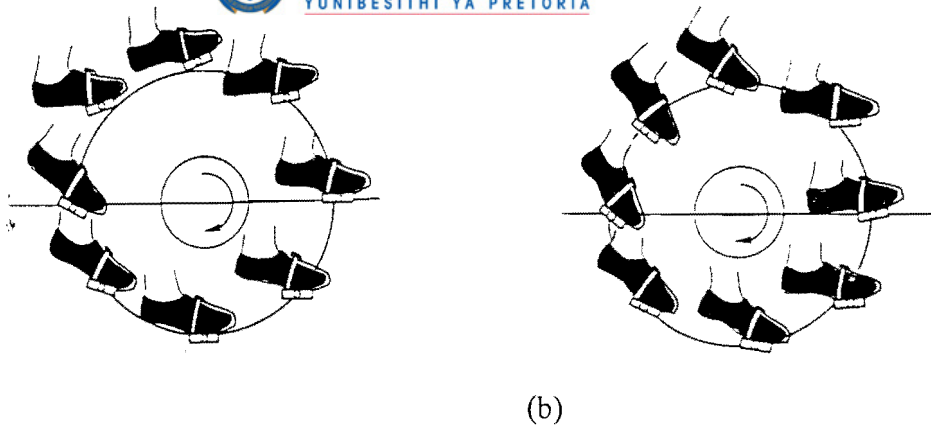

Figure 2: The ankling patterns occurring during cycling: (a) Ankling patterns from the popular litreature and (b) patterns measured from elite riders (Burke, 1986).

Table 1: Lower extremity joint excursions during cycling (Burke, 1986)

	Total hip motion	Total knee motion	Total ankle motion
Houtz & Fisher, 1959	20 - 40°	40 65°	
Cavanagh & Sanderson, 1986	43°	74°	50°

The movement data as described above, provides some information on how the movements of the legs are coordinated to provide application of force to the pedals (Burke, 1986).

2.3.2 Biomechanics of the Bicycle

a. The force that creates motion

Once the rider starts pedalling, major differences exist in the force situation. First of all, the wheels are no longer just vertical forces. The ground reaction force of the front wheel acts slightly backward in reaction to the rolling resistance of the tyre. The force at the rear wheel acts forward, because of the fact that the propulsive force applied by the rider can easily overcome the rolling resistance. Figure 3 shows the horizontal component of force at the tyre as generated by the different

forces of the pedal. Force F_1 is the force applied by the rider to the pedal. F_1 has a moment about the crank axis equal to the product of the force and its perpendicular distance from the axis of rotation. The moment of the force is calculated directly as the product of force F_1 and crank length L_1 where the force is vertical and the crank horizontal:

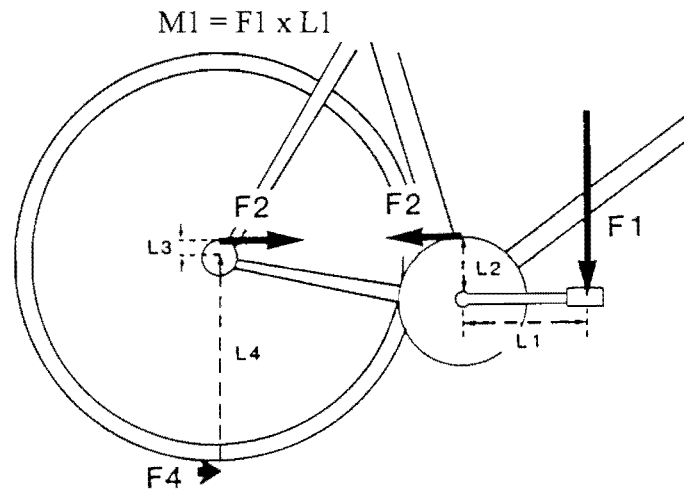

Figure 3: The relationship between pedal force and the horizontal component of force at the rear wheel (Burke, 1986; Heil et al., 1997)

b. The recovery phase

Through the cycle revolution, the forces responsible for limb movement from zero to 195° , are muscle contraction and the weight of the limb. Between 195° and 360° , the recovery phase, the pedal force is mainly caused by the weight of the limb (Ericson & Nisell, 1988). When a downward force is exerted on the pedal during the recovery phase, the opposite leg is helping this leg to recover, if not, the rider recovers by the action of the leg's own muscular effort. This will have a negative effect on oxygen consumption (Cavanagh & Sanderson, 1986).

At a crank position slightly beyond 180° , the crank force goes down to zero. Beyond 180° in the crank cycle, a significant force is applied to the crank in the direction opposite of the crank rotation during the upward movement of the leg (Hoes et al., 1968; Patterson & Moreno, 1989). As the pedalling rate increases, the

magnitude of the applied forces also starts to increase (Patterson & Moreno, 1989). At pedalling rates of 100 to 120 rpm, the retarding force that is applied to the crank by the upward moving leg is greater than 25% of the force applied by the leg pushing downwards on the opposite side. This increases the force that must be exerted by the downward pushing leg. At slower pedalling rates the cyclist passively rests his foot on the pedal during the upward movement. As the pedalling rate increases, the force applied during the upward movement of the leg decreases continuously from a relatively higher value compared to the slower pedalling rate. This suggests that there is more active muscle contraction (Edwards et al., 1977; Patterson & Moreno, 1989). At a pedalling rate of 120 rpm this relaxation time would represent a rotation of 72°. The inability of the muscle to contract and relax more rapidly can be used to explain why the force continues further into the crank cycle than is desirable (Patterson & Moreno, 1989). The optimum pedalling rate depends on the cyclist's coordination and the ability to apply the forces to the pedals in a direction perpendicular to the crank arm. A lack of training or the development of in- coordination as the result of fatigue, may lower the preferred pedalling rate, because of the fact that the pedal forces will start increasing at a lower pedalling rate. The term 'optimal pedalling rate' may differ depending whether it is used in the sense of economical movement, maximum power production, fatigue or a comfortable cycling zone (Patterson & Moreno, 1989).

Benecke et al. (1983) came to the conclusion that the ankle dorsiflexion joint deficits can create an unfavourable angle of application of forces to the pedal. In a study done by Rosecrance & Giuliani (1991) they identified abnormal ankle kinematic trajectories during the upstroke (recovery phase) of the pedalling cycling in a group of subjects with hemiplegia. They also found that neurological unimpaired subjects produced a predictable dorsiflexion / plantar flexion ankle pattern during the same cycling pattern. The results showed that ankle joint mobility is an important contributor to altered pedalling forces, especially during the recovery phase.

Lastly, during the recovery phase (fig. 4: position 10-17), a force is still pushing down on the pedals. This will produce a counter torque opposing forward movement and will be seen as a negative-effective force. The rider hardly applies any pulling-up force to the pedal under these conditions (Burke, 1986).

c. Forces that vary with time - The clock diagram

Considering the changes in forces as the crank rotates through 360° , a pictorial representation of typical data through one pedal cycle is shown in fig 4. This represents data for one leg at 20 points in the crank revolution from elite cyclists for a steady-state 4- minute ride in a clock diagram. In the clock diagram it is clear that the force vector hardly ever has a vertical orientation, in other words a direct push down. In the first 130° of the cycle the force application can be described as a push downward and forward through positions 0 to 7. Most of the remainder of the revolution is a downward and backward stroke. It is also clear that the force in position 4 is very close to a 90° angle with the crank and is therefore close to being 100% effective (Burke, 1986). From this point, the angle between the resultant force vector and the crank rapidly decreases and therefore loses its effectiveness.

Lastly, during the recovery phase, we can see that through positions 10 to 17, a force is still pushing down on the pedals. This will produce a counter- torque opposing forward movement and will be seen as a negative-effective force. The rider hardly applies any pulling-up force to the pedal under these conditions (Edwards et al., 1977; Burke, 1986).

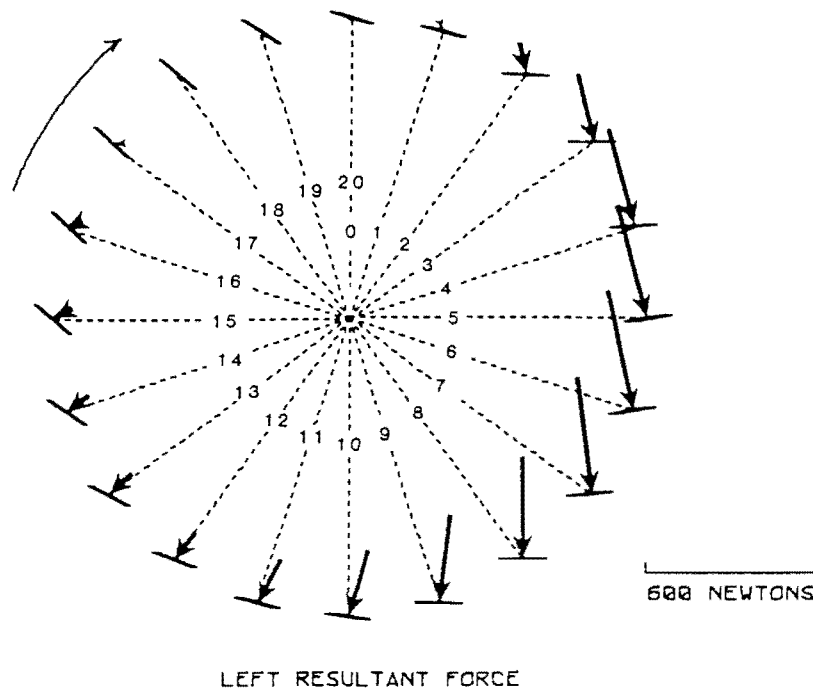

Figure 4: The clock diagram: The orientation of the pedal and the resultant force vector are shown at 20 positions of the crank (Burke, 1986).

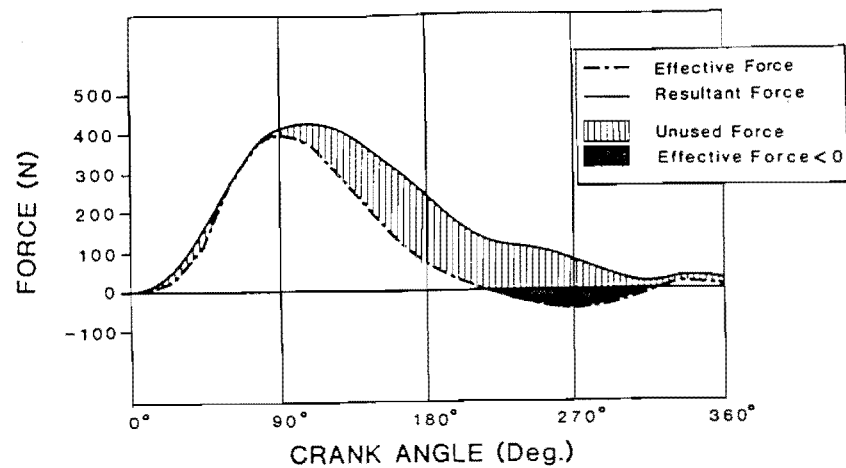

Figure 5: The resultant force (solid line) and the effective force (chain dotted line) for the right leg plotted against crank angle from the same riders and conditions as Figure 1. The shaded area represents the force that is not used for propulsion. The effective force peaks at about 90°, whereas the resultant force peaks at 105° (Burke, 1986).

d. The Criterion Diagram

For the purpose of this study we will divide the crank up into 15° sectors (fig. 6). To determine the various forces over each segment a mathematical technique called integration is used. When a force is summed over a certain time, the resulting value is known as an impulse. Figure 6 gives new insight into where in the pedal cycle the major propulsive impulse occurred. The forces applied in the third and fourth segments from TDC (between 60° and 120°) together comprise over 55% of the total propulsive impulse applied in the revolution. (Edwards et al., 1977; Burke, 1986; Patterson & Moreno, 1989).

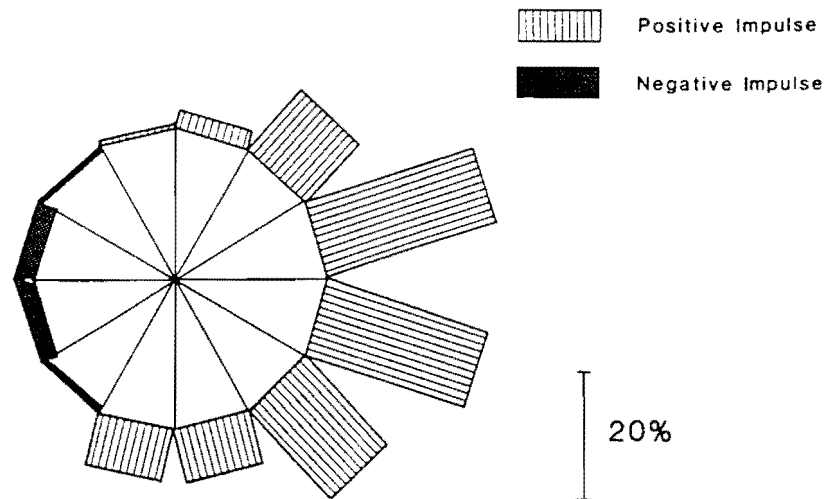

Figure 6: The contributions to propulsion for 12 segments of the crank revolution. The size of each bar represents the percentage of impulse (the effective force over time) that the rider exerted in this part of the crank revolution. 50% of the propulsive impulse is delivered between 60° and 120° after TDC. The scale bar represents 20% of the total.

(Burke, 1986)

2.3.3 Pedalling Rate:

An apparent conflict exists between the most economical bicycle pedalling rate with the minimum oxygen uptake at a given power output and a higher pedalling rate which is mostly used by competitive cyclists (Coast & Welch, 1985; Coast et al., 1986; Redfield & Hull, 1986; Kram, 1987;). Many studies showed that the most economical pedalling rate is between 40 and 70 rpm (Eckermann & Millahn, 1967; Seabury et al., 1977; Patterson & Pearson, 1983; Coast & Welch, 1985) and it increases when the power output increases (Patterson & Moreno., 1989). Hagberg et al (1981) reported that a pedalling rate of 90 rpm will be the preferred pedalling rate for competitive cyclists working at 80% of their VO_2 -max (Pugh, 1974; Hagberg et al., 1981; Marsch & Martin, 1996). However, cadences of 50-60 rpm are consistently reported as the most economical and efficient (Boning et al., 1984; Croisant & Boileau, 1984; Coast et al., 1986; Marsh & Martin, 1996). Coast et al. (1986) have shown that the most economical pedalling rate for trained cyclists riding for 20-30 minutes at a VO_2 -max of 85% was between 60 and 80 rpm. Cyclists can also minimize peripheral muscle fatigue by pedalling at a rate that produces a higher than optimum metabolic rate, but at the same time lowers crank forces (Patterson & Moreno, 1989).

In a study done by Patterson & Pearson (1983) they measured both oxygen uptake and the forces applied to the pedals simultaneously. They confirmed that minimum oxygen uptake occurs at 50-60 rpm for cyclists working at 30% or 60% of their VO_2 -max and that the applied forces on the pedals became less optimally directed as the pedalling rate increases. (Loftin et al., 1990). The average force effectiveness index, which refers to the ratio of the force applied perpendicularly to the crank arm and the force applied to the pedals, will decrease from 0.5 to 0.35 when the pedalling rate changes from 40 to 90 rpm at 60% of the VO_2 -max (Lafortune & Cavanagh, 1980).

2.3.4 Saddle Height:

According to Timmer (1991), alterations in seat height and pedal position can change the cyclist's ability to turn the crank. By raising or lowering the seat, the action of every lower extremity muscle during cycling may be changed (Burkett & Darts, 1987; Timmer, 1991). By adjusting the seat height the joint angles and ranges of motion change and the length-tension relationships of the lower extremity muscles alter. According to Mandroukas (1990), a low saddle height affects muscular work negatively. This results in the fact that the cyclist consumes more oxygen and works harder with a decreased efficiency (Faria & Cavanagh, 1978; Timmer, 1991).

The total length-tension curve for skeletal muscle fibres, "consists of a series of straight lines connected by short curved regions" (Aidley, 1978). Although isometric tension is proportional to the number of interacting cross-bridges, total tension increases as length increases (fig. 7). A high saddle causes muscle length to increase and also causes an increase in efficiency. This is attributed to the increased ability of the muscle to apply force in its elongated state. It is then clear that certain cycle modifications that increase initial length of the muscle might increase the cyclist's ability to exert tension (Burke, 1989)

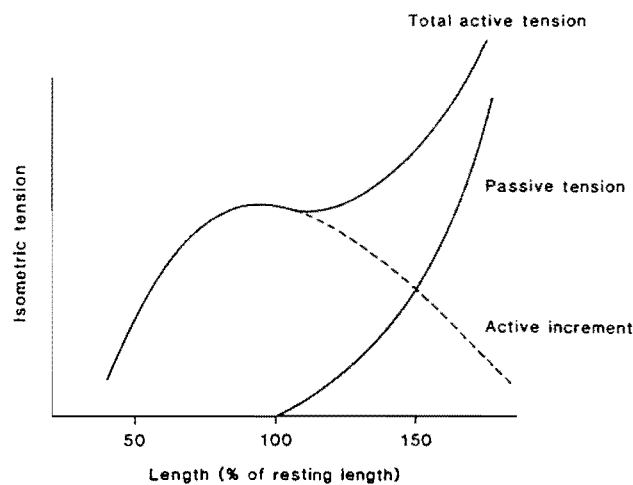

Figure 7: The length-tension relation of a muscle (Burke, 1989)

The saddle height is the most critical variable for effective cycling. The leg should be able to stretch comfortably without completely stretching the knee. Over stretching of the muscles would force excessive force and rotation on the joint (Van der Plas, 1989). There are three methods to establish the correct saddle height:

a. The 109% rule (fig. 8) was developed at the Loughborough University in England. The inseam leg length is measured while the rider stands with his back against a wall, legs straight, feet 5cm apart and wearing thin sole shoes with flat heels. The vertical length is measured from the location of the crotch to the floor. This length is then multiplied by 1,09 which is the optimal distance between the top of the saddle and the pedal axle (Burkett & Darst, 1987; Van der Plas, 1989; Timmer, 1991).

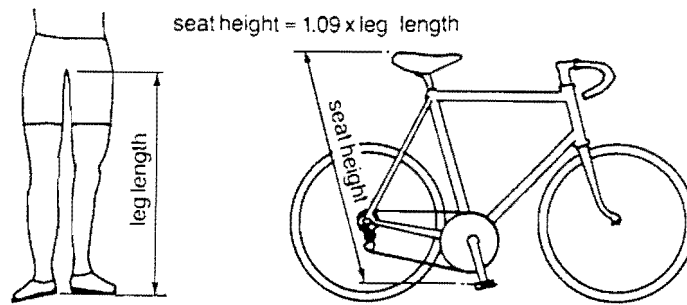

Figure 8: Seat Height (109%) (Van der Plas, 1989)

b. The trial-and-error method (fig. 9) is less theoretical and easy to carry out without help. Adjust the seat up or down until it is set at such a height relative to the pedals that the heel of the cycling shoes can rest on the pedal with the knee nearly straight, but not strained. Raise the saddle by 12mm above this height to get the final saddle height (Van der Plas, 1989).

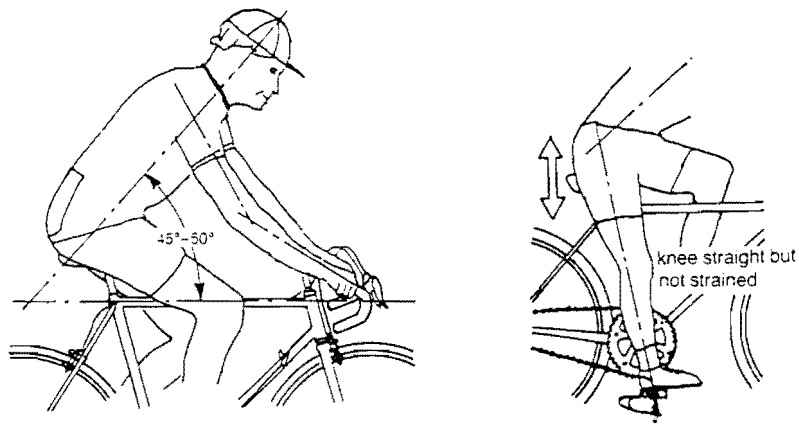

Figure 9: Seat Height (conventional) (Van der Plas, 1989)

c. The rider stands barefoot upright with his back against a wall and feet 15cm apart. Measure the distance from the floor to the greater trochanter and multiply this dimension by 0.96. To establish the optimal seat height, measure the distance between the top of the saddle (near its centre) and the centre of the pedal axle (fig. 10) (Van der Plas, 1989).

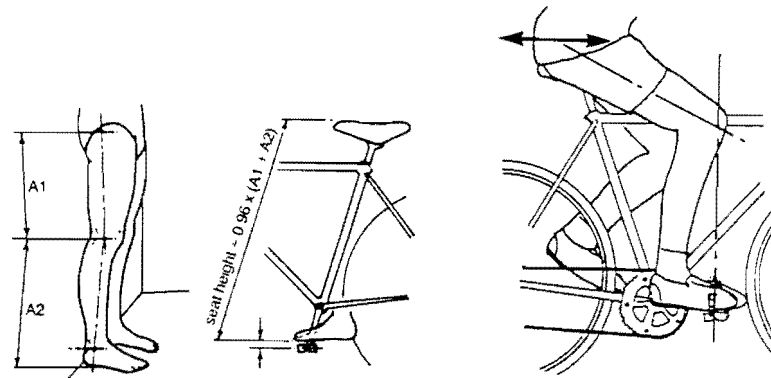

Figure 10: Seat Height (hodes) (Van der Plas, 1989)

2.4 ANATOMY AND FUNCTIONING OF THE LEG MUSCLES

Gonzalez & Hull (1989) stated that the variability related to pedal movements during pedalling are easy to measure and control, since the kinematics of the legs are constrained by the bicycle's crank trajectory.

Some thigh muscles, which are active during leg movement, act only at the hip joint, others only at the knee, while some of the muscles act at both the joints. The most anterior muscles of the hip and thigh tend to flex the femur at the hip and extend the leg at the knee. The posterior muscles of the hip and thigh mostly act in extending the thigh and flexing the leg. (Meiring et al., 1994). The third muscle group in this region is the adductor. Their function is to adduct the thigh and they have no effect on the leg. The hip joint is a ball-and-socket joint permitting flexion, extension, abduction, adduction, circumduction and rotation. The muscles that effect these movements of the thigh are among the most powerful muscles in the body. The most important thigh muscles, are the iliopsoas, tensor fascia latae and the rectus femoris. They are supported by the sartorius for adduction. The most powerful and prime mover of thigh flexion is the iliopsoas (Kendall et al., 1983; Marieb, 1995).

The extension is controlled primarily by the hamstring muscles of the posterior thigh (Meiring et al., 1994). The gluteus maximus is activated during forceful extension. The buttock muscles that lie parallel to the thigh abduct the thigh and rotate it medially. Medial rotation is opposed by the six small lateral rotators that play an important role during walking (Kendall et al., 1983; Marieb, 1995).

The main movement of the knee joint is flexion and extension. The quadriceps femoris muscle is the sole knee extensor and is also the most powerful muscle in the body. The quadriceps are antagonized by the hamstrings (Meiring et al., 1994). The hamstrings are the prime movers of knee flexion and they also act to rotate the leg when the knee is semi - flexed (Marieb, 1995).

2.4.1 Anterior muscles of the pelvis:

2.4.1.1 Iliopsoas: The iliopsoas is a composite of two muscles, the iliacus and the psoas major.

a. *Iliacus*: The iliacus is large and fan-shaped and more of a lateral muscle. It serves as the prime mover of hip flexion and it flexes the thigh on the trunk when the pelvis is flexed.

b. *Psoas major*: The psoas major is a long, thick muscle, more at the medial side of the pair. As the iliacus, it also effects lateral flexion of the vertebral column and is a very important postural muscle. (Meiring et al., 1994; Marieb, 1995)

2.4.2. Posterior muscles of the gluteus

a. *Gluteus maximus*: The gluteus maximus is the largest and most superficial of all the gluteus muscles. It overlies the large sciatic nerve. It is a major extensor of the thigh and is most effective when the thigh is flexed and when force is necessary. It also rotates the thigh laterally and is an antagonist of the iliopsoas muscle. (Meiring et al., 1994).

b. *Gluteus medius*: The gluteus medius is a thick muscle that is largely covered by the gluteus maximus. It is considered a safer site for injection than the gluteus maximus, because there is less chance of injuring the sciatic nerve. This muscle abducts the thigh, rotates it medially and gives stability to the pelvis (Kendall et al., 1983).

c. *Gluteus minimus*: The gluteus minimus is the smallest and the deepest of all the gluteal muscles. As the gluteus medius, it also abducts the thigh, rotates it medially and gives stability to the pelvis (Marieb, 1995)

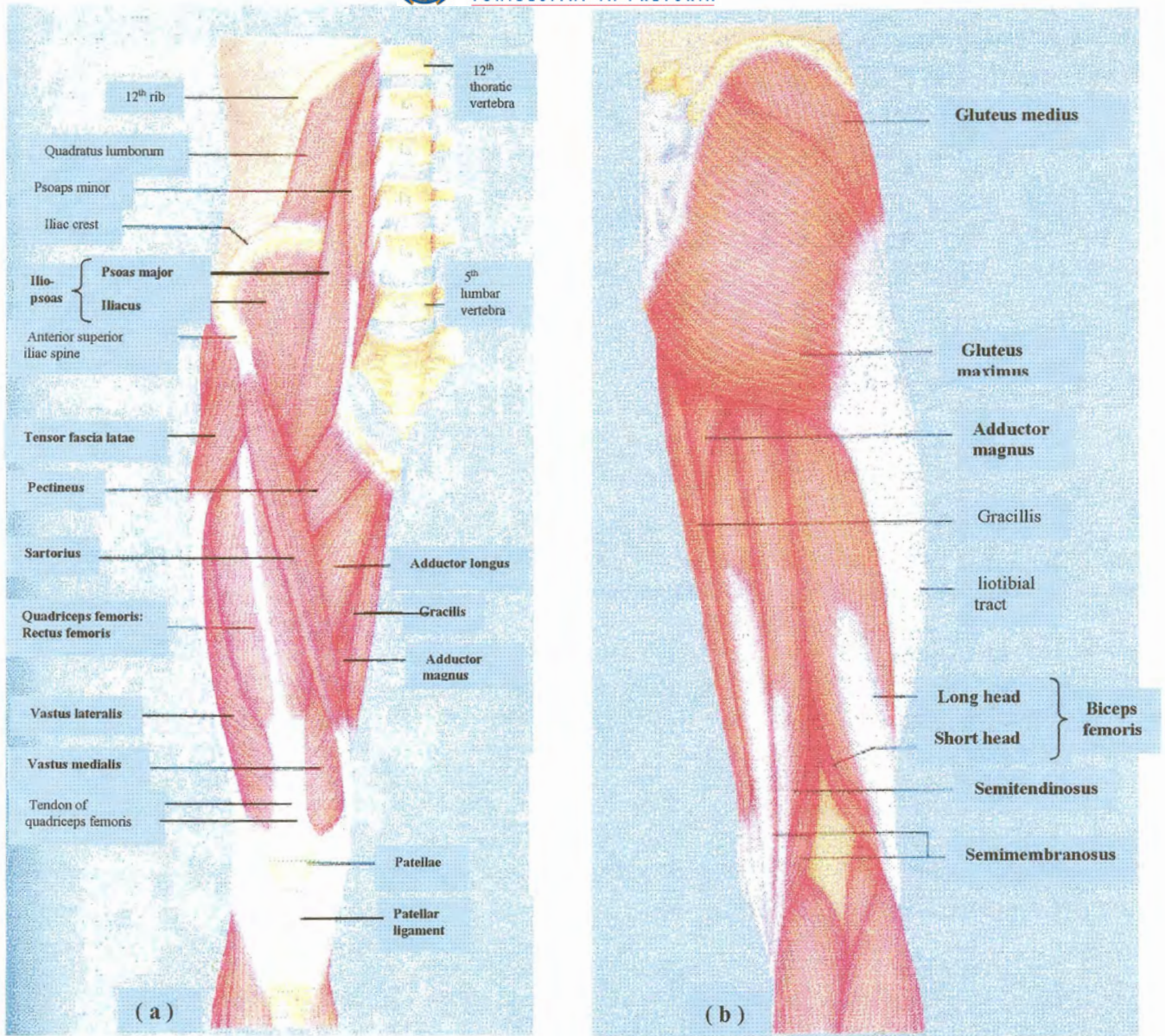

Figure 11: (a) Anterior view of the deep muscles of the pelvis and superficial muscles of the right thigh. (b) Superficial view of the gluteus muscles of the buttock and the hamstring muscles of the thigh (Marieb, 1995).

2.4.3 Anterior muscles of the thigh

Quadriceps femoris: The quadriceps femoris arises from four separate heads that form the front and the side of the thigh. These four heads have a common insertion, the quadricep tendon that inserts into the patella and the tibial tuberosity. The quadriceps is a powerful knee extension used in cycling (Kendall et al., 1983; Meiring et al., 1994).

a. *Rectus femoris:* The rectus femoris is a superficial muscle anterior on the thigh and runs straight down the thigh. It is also the only muscle in this group that crosses the hip. Its main functions are to extend the knee and to flex the thigh at the hip.

b. *Vastus lateralis:* The vastus lateralis forms part of the lateral aspect of the thigh and is a common intramuscular injection site. Its function is to extend the knee.

c. *Vastus medialis:* The vastus medialis is found on the infero- medial aspect of the thigh. It helps to extend the knee and also to stabilize the anterior fibres of the patella.

d. *Vastus intermedius:* The vastus- intermedius is obscured by the rectus femoris and lies between the vastus lateralis and the vastus medialis on the anterior thigh. Its function is extension of the knee (Kendall et al., 1983; Marieb, 1995; Meiring et al., 1994)

2.4.4 Posterior muscles of the thigh

The Hamstrings: The hamstrings are fleshy muscles of the posterior thigh that cross both the knee and the hip joints. They are prime movers of thigh extension and knee flexion. The ability of the hamstrings to act on one of the two joints

depends on which joint is fixed (Kendall et al., 1983) If the knee, for example, is extended, they will promote hip extension and if the hip is extended, they promote knee flexion. If the hamstrings are stretched, they tend to restrict full accomplishment of the antagonistic movements, for example, it is very difficult to flex the hip and touch the toes while the knees are fully extended (Meiring et al., 1994).

a. *Biceps femoris*: the biceps femoris is the most lateral muscle of the group and arises from two heads. It aids in extension of the thigh, flexion of the knee and lateral rotation of the leg, especially when the knee is flexed.

b. *Semitendinosus*: the semitendinosus lies medial to the biceps femoris and is actually quite fleshy. Its function is to extend the thigh at the hip, flex the knee and help the semimembranosus to rotate the leg medially.

c. *Semimembranosus*: this muscle is found deep to the semitendinosus. It extends the thigh, flexes the knee and medially rotates the leg.
(Marieb, 1995; Meiring et al., 1994)

2.4.5 Anterior muscles of the lower leg

All the muscles of the anterior compartment are dorsiflexors of the ankle and a common innervation at the peroneal nerve. “Shinsplints” are a common painful inflammatory condition of the anterior compartment of the lower leg.

a. *Tibialis anterior*: The tibialis anterior is a superficial muscle of the anterior leg and is a prime mover of dorsiflexion. It inverts the foot and assists in supporting the medial longitudinal arch of the foot (Meiring et al, 1994).

b. Extensor digitorum longus: The extensor digitorum longus is found on the anterolateral surface of the leg, lateral to the tibialis anterior muscle. This muscle dorsiflexes the foot and is a prime mover of toe extension.

c. Peronius tertius: The peronius tertius is a small muscle, fused with the distal part of the extension digitorum longus. Its main function is dorsiflexion and eversion of the foot.

d. Extensor hallucis: The extensor hallucis lies deep to the extensor digitorum longus and the tibialis anterior and it extends the big toe and dorsiflexes the foot (Kendall et al., 1983; Meiring et al., 1994).

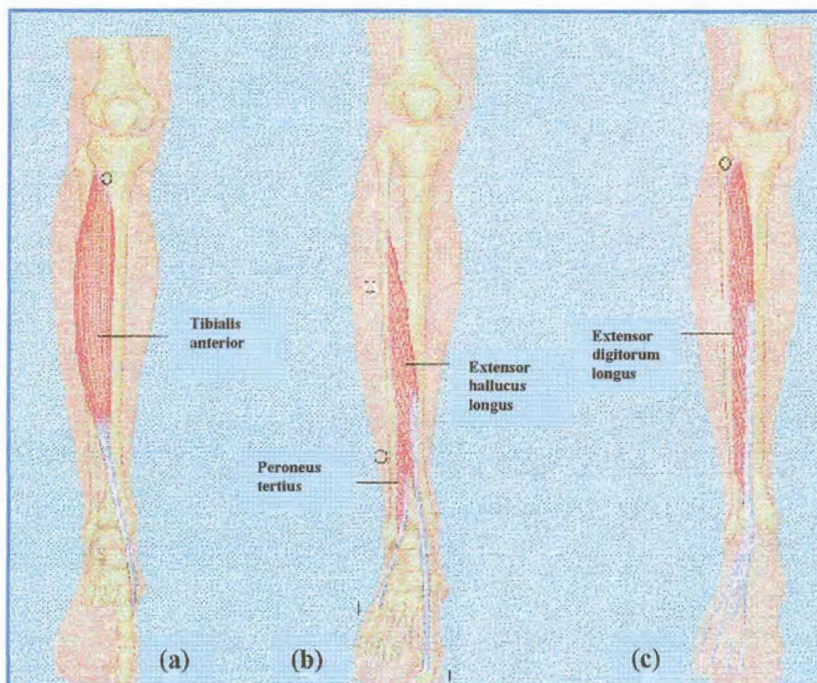

Figure 12: Muscles of the anterior compartment of the right leg (Marieb, 1995)

2.4.6 Posterior muscles of the lower leg

Triceps surae: This refers to the muscle pair, the gastrocnemius and soleus, which forms the posterior calf and inverts via a common tendon into the calcaneus of the heel, the achillis tendon.

a. *Gastrocnemius:* The gastrocnemius is the superficial muscle of the pair and consists of two bellies that form the proximal curve of the calf. The gastrocnemius plantar flexes the foot when the knee is extended, and it also flexes the knee when the foot is dorsiflexed.

b. *Soleus:* The soleus lies deep to the gastrocnemius on the posterior surface of the calf. Its function is plantarflexion of the ankle and it is also an important loco- motor and postural muscle (Kendall et al., 1983; Marieb, 1995; Meiring et al., 1994).

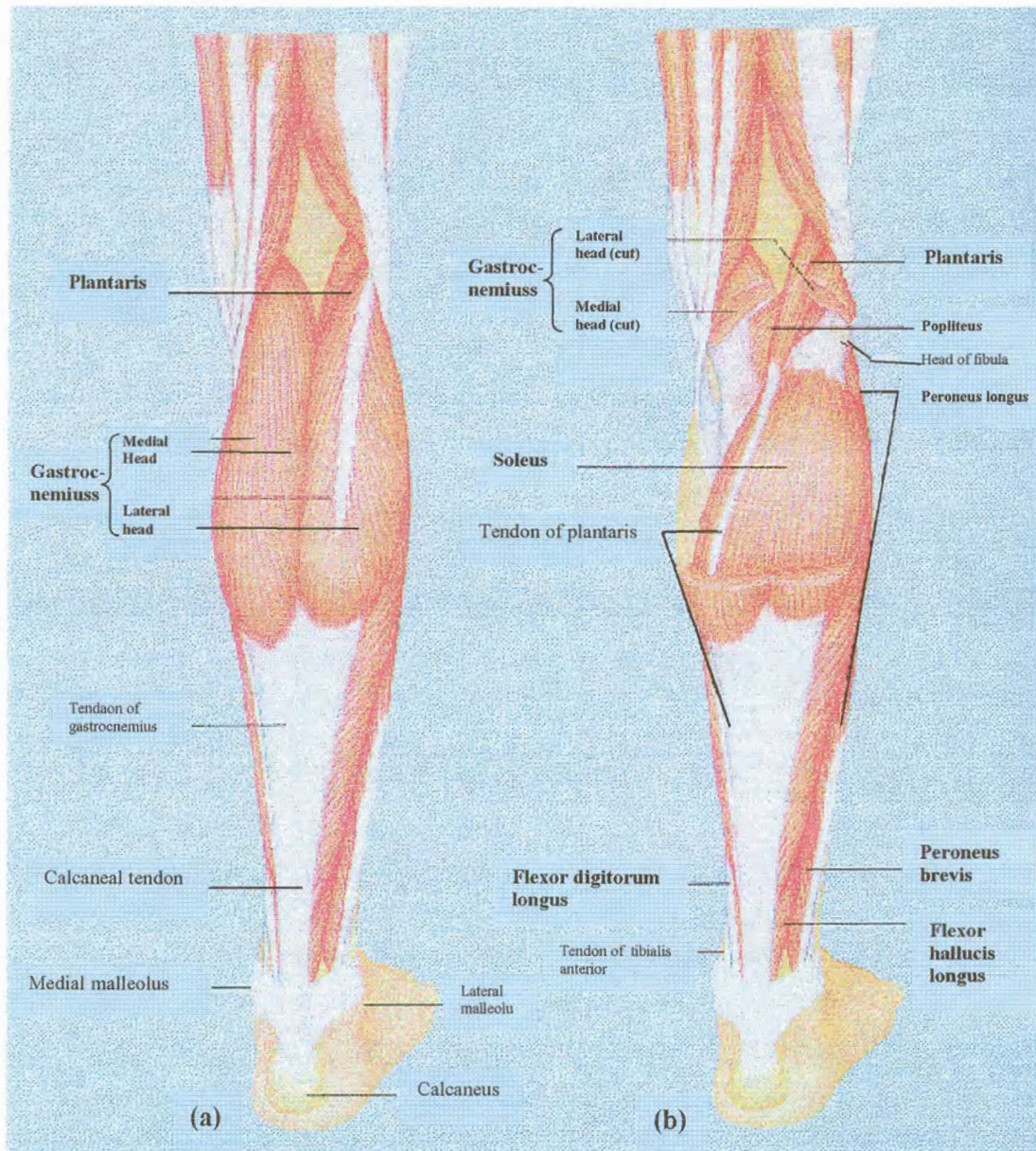

Figure 13: Muscles of the posterior compartment of the leg: (a) Superficial view of the posterior leg. (b) The fleshy gastrocnemius has been removed to show the soleus immediately deep to it (Marieb, 1995)

2.4.7 Muscle functions during cycling

2.4.7.1 The main active muscles:

According to Van der Plas (1989) there are essentially six muscle groups that carry out most of the work involved in propelling a bicycle:

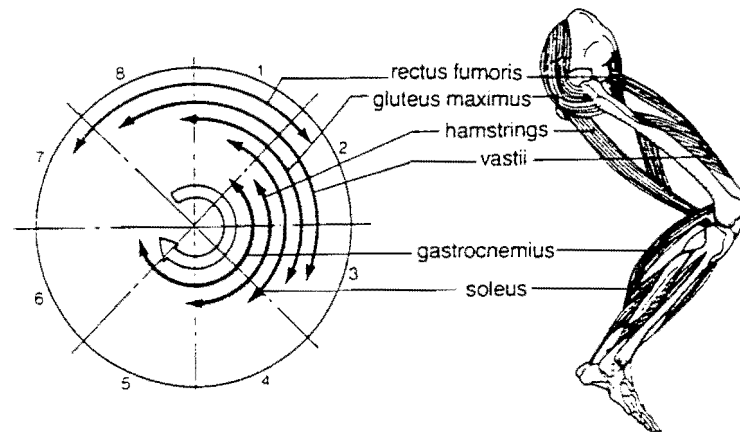

Figure 14: Major muscles active during cycling (Van der Plas, 1989).

- a. rectus femoris;
- b. gluteus maximus;
- c. hamstrings;
- d. vastii;
- e. gastrocnemius; and
- f. soleus

According to studies done by Glass et al. (1998) the IEMG detected more consistently from the rectus femoris muscle than the vastus lateralis. Nagata et al. (1981) and Viitasalo et al. (1985) showed that there was a breakpoint in the vastus lateralis, which corresponded with the lactate- and ventilatory threshold during incremental cycling exercise though the fatigue threshold for the rectus femoris occurred at a significant lower work rate than the vastus lateralis. This shows that these two muscles differ in their pattern of fatigue during exercise on a bicycle. It

appears that the rectus femoris muscle is the muscle to use for identification of the IEMG threshold. The results of this study also indicate that the IEMG threshold occurred at the same VO_2 value as the ventilatory threshold (Glass et al., 1998).

By analyzing the nerve impulses in an EMG (electromyograph), it is possible to establish which muscle is active at any point during the pedalling cycle and is broken into 8 octants. (Van der Plas, 1989).

- * Octant 1: rectus femoris, vastii, gluteus maximus, soleus
- * Octant 2: rectus femoris, vastii, gluteus maximus, soleus, gastrocnemius
- * Octant 3: vastii, gluteus maximus, soleus, gastrocnemius, hamstrings
- * Octant 4: soleus, hamstrings, gastrocnemius
- * Octant 5: hamstrings, gastrocnemius
- * Octant 6: gastrocnemius
- * Octant 7: rectus femoris
- * Octant 8: rectus femoris, vastii, gluteus maximus

(See figure 14)

Research done by Burke (1989) shows that the tibialis anterior plays an important role in dorsi flexion of the foot during cycling. The maximum dorsiflexion occurs at 90° crank position (Timmer, 1991). Motion in the opposite direction resulting in plantar flexion is produced by the soleus and gastrocnemius muscles. The maximum plantar flexion occurs at approximately 285° (Burke, 1989; Timmer, 1991). Effective propulsion relies largely on the ability of the ankle joint to keep the foot in a stable position during human locomotion. Therefore, a firm interface between the ankle and the environment is essential (Rodgers, 1988; Pierson-Carey et al., 1997). According to Giuliani (1990) any bio- mechanical or neurological impairments may restrict the propulsive capabilities of the ankle. Ankle immobilization or muscle weakness can manifest in a reduction of mobility at the ankle and place the foot in positions that are less effective during the propulsive

phase of locomotion (Cornwall, 1984; Giuliani, 1990; Smidt, 1990). The ankle undergoes motion excursions throughout one crank cycle with maximum plantar flexion that occurs at the end of the down stroke phase and maximum dorsiflexion at the end of the upstroke phase. By maintaining the ankle in a locked, neutral position during the pedalling phase, the resultant forces throughout the crank cycle, are reduced especially by the maximum power phase at the end of the down stroke (Pierson-Carey et al., 1997).

Burke (1986) also stated that the hip flexors, the iliacus and the psoas, are very important in moving the thigh up towards the chest (fig. 15 and fig. 16). During the first 45° of the pedal cycle, the gluteus maximus acts alone to extend the hip. During the last 45° of hip extension, the hamstrings work alone to extend the hip (Timmer, 1991). This action creates the possibility for the rest of the leg muscles to move downwards on the pedal and to create power.

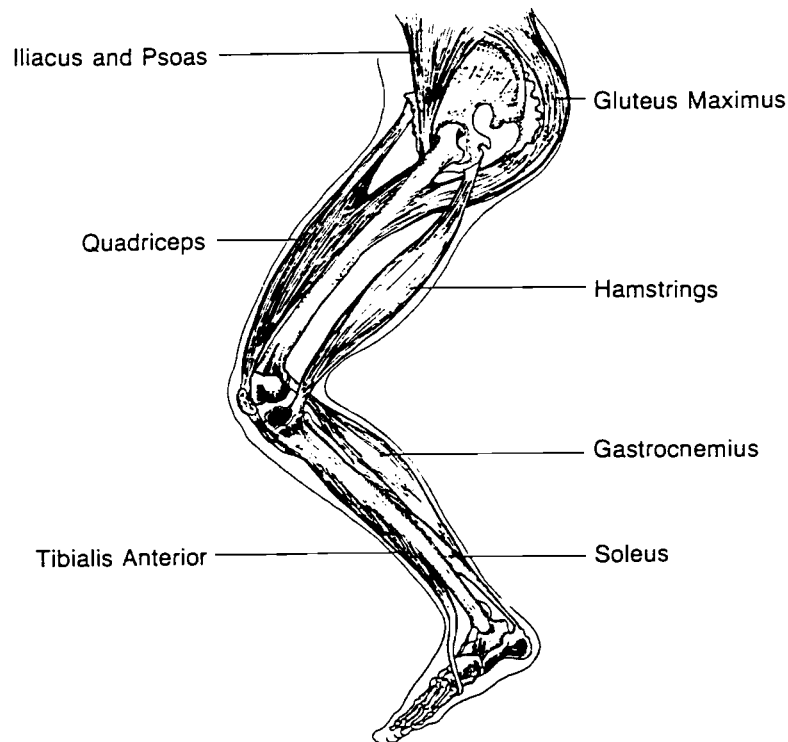

Figure 15: The major muscles of the leg (Burke , 1986)

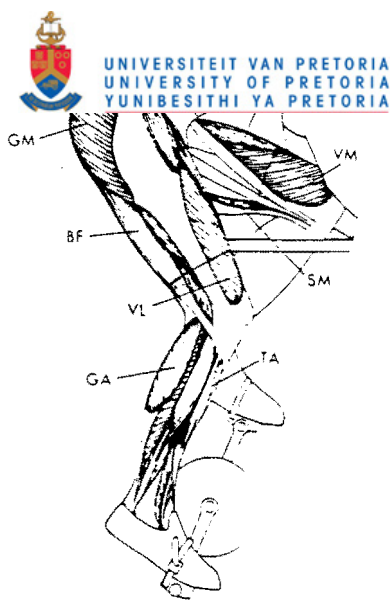

Figure 16: Some of the major lower-extremity muscles used during cycling: Gluteus Maximus (GM), biceps femoris (BF), vastus lateralis (VL), gastrocnemius (GA), tibialis anterior (TA), semimembranosus (SM), vastus medialis (VM), rectus femoris (RF) (Burke, 1986).

2.4.7.2 Contraction of the Skeletal Muscle

As known, single muscle cells respond to stimulation in an all-or-none fashion. A skeletal muscle, consisting of huge numbers of cells, contracts with varying force and for different periods of time (Meiring et al., 1994; Marieb, 1995).

Power output of the muscles can be defined as the product of force and velocity (Hintzy et al., 1999). Arsac et al. (1996) reported a positive relationship between inter- individual variations of maximal power and optimal velocity at different activities from cycling to handball. These results show that both optimal velocity and optimal power might be related to the same functional property of the muscles. Muscle fibre distribution has been found to be a functional factor related to both optimal power and velocity, in other words, the higher the percentage of fast-twitch fibres, the higher optimal power and velocity (McCartney et al., 1983; Hautier et al., 1996).

Each muscle is served by at least one motor nerve with hundreds of motor neuron axons. A motor neuron with all the muscle fibres it supplies is called a motor unit. When a motor neuron transmits an electrical impulse, all the muscle fibres that it innervates then respond by contracting. The large, weight-bearing muscles, such as the quadriceps, have large motor units. The response of a muscle to a single stimulus is called a muscle twitch. The muscle receiving the stimulus contracts quickly and then relaxes (Meiring et al., 1994; Marieb, 1995). There are three obvious phases in a twitch:

- a. **Latent Period:** This period is the few milliseconds following stimulation when excitation-contraction coupling is occurring. At this stage no response is seen on the myogram (fig. 17a)
- b. **Period of Contraction:** This is the time from the onset of shortening to the peak of tension development. At this stage the cross-bridges are active and the myogram traces reach a peak (fig. 17a)
- c. **Period of Relaxation:** The period of relaxation follows the period of contraction. Since the contractile force is no longer generated, the muscle tension decreases to zero and the tracing gradually returns to the baseline. The muscle now returns to its initial length (fig. 17a) (Meiring et al., 1994; Marieb, 1995)

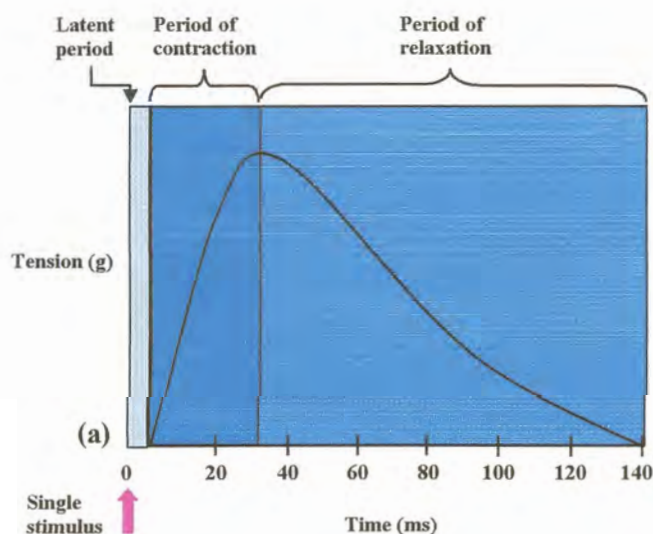

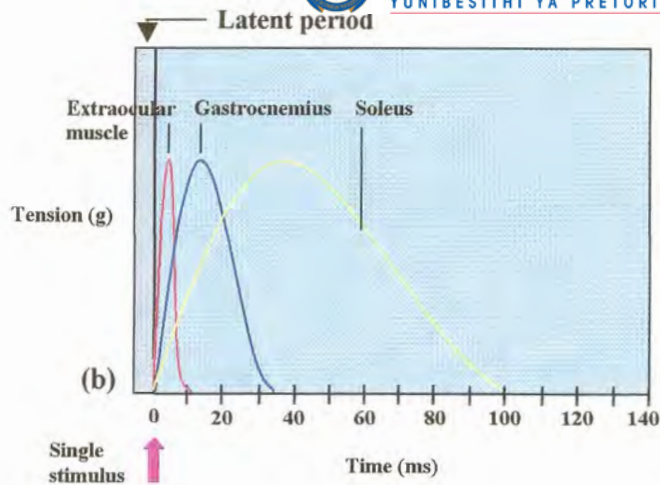

Figure 17: (a) Myogram tracing of a twitch contraction, showing its three phases: the latent period, the period of contraction, and the period of relaxation. (b) Comparison of the twitch responses of the extra-ocular, gastrocnemius, and the soleus muscle (Marieb, 1995).

2.4.7.3 Muscle Fatigue: Wave Summation and Tetanus

When two stimuli are delivered to a muscle in rapid succession, then the second twitch will be stronger than the first. This phenomenon is called **wave-** or **temporal summation** and it occurs when the second contraction is induced before the muscle has completely relaxed after the first contraction (fig. 18). Since the muscle is already partially contracted and more calcium is being released, tension produced by the second contraction causes more shortening than the first contraction and the contractions are summed (Meiring et al., 1994). If the stimulus is held constantly and the muscle is stimulated at a faster and faster rate, the relaxation time between the twitches becomes shorter, the concentration of calcium higher and the degree of summation greater. Finally, all the evidence of relaxation disappears and the contraction fuses into a sustained contraction, the **tetanus** (fig. 18). Prolonged tetanus inevitably causes the muscle to lose its ability to contract and its tension drops to zero, a condition called muscle fatigue (fig. 18) (Kendall et al., 1983; Meiring et al., 1994; Marieb, 1995).

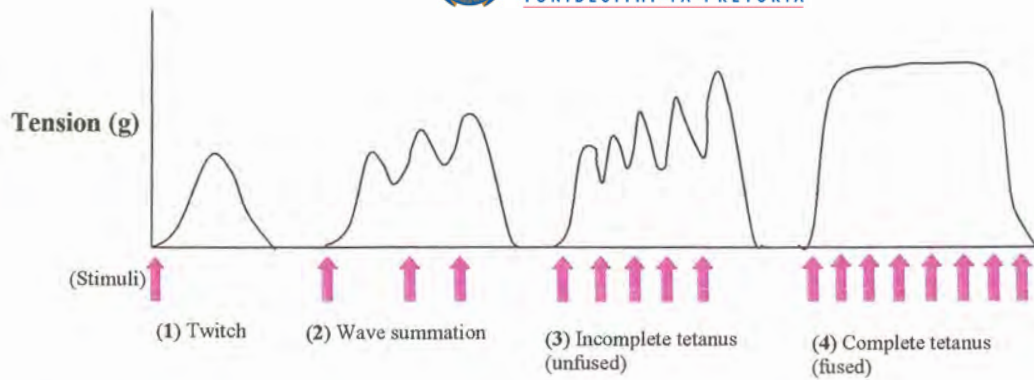

Figure 18: Wave summation and tetanus (Marieb, 1995)

2.4.7.4 Muscle strength:

Muscle strength can be defined as the maximal force that can be exerted in a single voluntary contraction (Sharkey, 1979). The dynamic activity of a muscle can either be concentric or eccentric. With concentric muscular contraction the muscle shortens as it develops tension in order to overcome the external resistance to cause movement. Concentric contractions are common in weight lifting (McArdle et al., 1991, Fox et al., 1993; Perrin, 1993). Eccentric muscle contractions occur when the external resistance exceeds the muscle force and the muscles lengthen while it develops tension (McArdle et al., 1991; Fox et al., 1993; Perrin, 1993). Strength can be measured and improved in several ways:

a. Isotonic (Iso = same; tonic = tone):

This is a dynamic strength and it indicates the maximal weight that can be lifted through a joint's range of motion for either 1 repetition (1RM) or 10 (Perrin, 1993; Sharkey, 1979). Isotonic strength can be measured dynamically by using dumbbells or barbells (Perrin, 1993) It measures the hardest part of the lift, which is at the beginning. The lift becomes easier after you overcome the initial resistance and bad angle of pull. Weight lifting in a gymnasium setup or the use of free weights is a typical isotonic mode of training (Sharkey, 1979). The resistance used is usually fixed at the greatest load that allows completion of the movement. The

consequence is that the resistance can not be greater than the maximal strength of the weakest muscle in the range of motion. Weight lifters often refers to this as “the sticking point” (Fox et al., 1993; Sharkey, 1979).

b. Isometric (Iso = same; metric = length):

Isometric or static tests, measure the strength of a subject while exerting a maximal force against an immovable object which results in permitting no observable joint movement (Perrin, 1993; Sharkey, 1979). The external length of the muscle stays the same (Fox et al., 1993) with no noticeable shortening of the muscle fibres or skeletal movements (McArdle et al., 1991). An isometric strength-assessment measures the muscle’s maximum potential to produce a static force (Perrin, 1993). Isometric strength is influenced by the angle at which the muscle is trained and it does not measure strength throughout the full range of motion (Sharkey, 1979). The advantage of isometric resistance is that it can be used fully in training a muscle group around a joint limited in range of movement by bracing or pathology (Perrin, 1993), because of the fact that no joint movement occurs (Sharkey, 1979).

c. Isokinetic (Iso = same; kinetic = speed):

James Perrine developed the concept “isokinetics”. Perrine and Hislop then introduced isokinetic exercise in the scientific literature in 1967, followed by Thistle, Moffroid and Lohman later in 1967 (Perrin, 1993). Isokinetic testing enables a person to measure strength throughout the full ranges of motion by using an electronic apparatus, for example the Cybex Norm. This enables the subject to generate as much force and angular movement during contraction (Perrin, 1993) and the muscle strength can be measured at different angles of muscle contraction (Sharkey, 1979). According to Sharkey (1979) isokinetic contractions can be defined as *a contraction against a resistance that varies in order to maintain high tension throughout range of motion, where the velocity of movement stays constant*. Fox et al. (1993) describes this change in resistance as **accommodating resistance**.

Studies done by Coyle (1979) and Thorstensson, (1976) found that there is a definite force-velocity relationship in muscle contraction and that it relates to the muscle fibre composition. There is a progressive decline in peak torque output in relation to an increase in angular velocity (McArdle et al., 1991).

The aim of isokinetic resistance training is to combine the best features of isometrics and weight training in order to provide muscle overload at a constant preset speed (McArdle et al., 1991; Fox et al., 1993). This way, an accommodating resistance is accomplished by using a mechanical device (McArdle et al., 1991). Isokinetic resistance provides a safer alternative to improve muscle strength, because when pain or discomfort is experienced by the subject, the dynamometer's resistance mechanism essentially disengages (Perrin, 1993). Theoretically, isokinetic training will make it possible to activate the largest number of motor units by consistently overloading the muscles to achieve their maximum force output capacity at every point in the range of motion (McArdle et al., 1991). The advantage of this device is that it enables the muscle to generate peak power output throughout the range of motion at a *controlled velocity of contraction* (McArdle et al., 1991; Perrin, 1993).

2.5 THE CYCLE PEDAL CRANK

2.5.1 The traditional crank - set

The crank-set consists of crank-arms, the chain ring and axle. The crank itself comes in steel and alloys (Burkett & Darst, 1987). Crank-arms of the older and cheaper bikes are attached to the bottom bracket axle by a cotterpin, which is at right angles to the axle. Unfortunately, these cotterpins tend to give trouble. The better bikes come out with cotterless crank-arms and have a tapered hole, which fits over the end of the axle (Beneke et al., 1989). The cotterless cranks use bolts or nuts to attach the crank arm to the axle (Burkett & Darst, 1987). The cranks are

essential levers which turn the gear. The efficiency of the leverage is affected by their length, therefore longer cranks give greater leverage (Beneke et al., 1989; Patterson & Moreno, 1989).

The length of the crank ranges from 165 to 185 millimeters where most standard bikes are fitted with 170 millimeter cranks (Beneke et al., 1989).

The choice of the crank lengths depends on the following aspects:

- * the type of bicycle (track or road);
- * the length of the rider's legs as well as his height;
- * the type of event being ridden; and
- * the individual pedalling style of the rider

(Beneke et al., 1989; Patterson & Moreno, 1989)

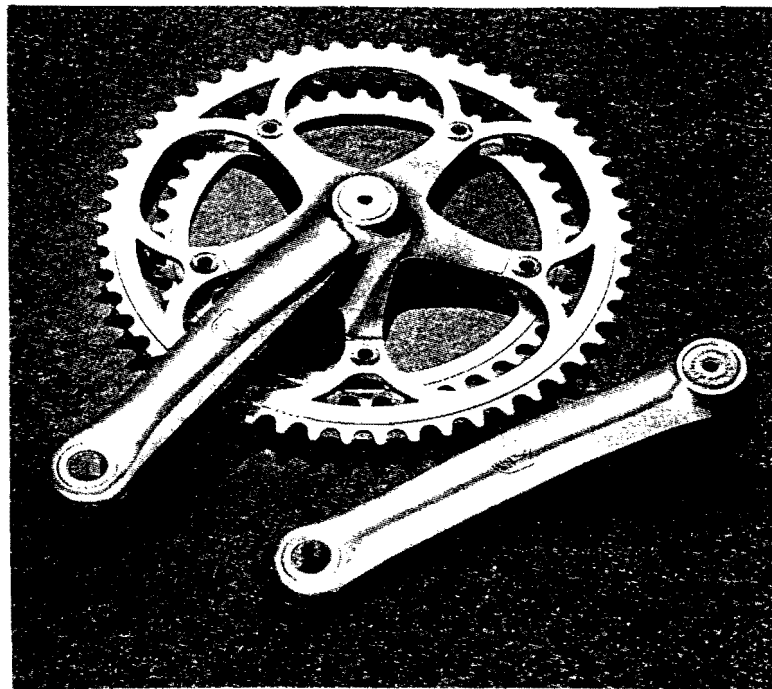

Figure 19: The traditional crank set consisting of two chain wheels and a pair of crank-arms (Beneke et al., 1989)

Crank and pedal forces have been measured for different purposes including the study of pedal force asymmetry between the limbs (Cavanagh et al., 1974; Daly & Cavanagh, 1976), and pedal force patterns throughout the pedal revolution (Brooke et al., 1981; Hull & Davis, 1981; McCartney et al., 1983). Similar studies found a tangential force between 195° to 360° crank angle, due to the vertically directed force from the weight of the limb which counteracts the crank and pedal motion upwards (Ericson & Nisell, 1988). During this passive recovery phase, the limb is moved upwards by forces applied to the contra- lateral pedal and the energy is supplied to the passive limb through these actions of passive movement (LaFortune & Cavanagh, 1983).

2.5.2 The new invented crank-set

a. Background of the invention

The concept of increasing the effective length of a pedal crank on a cycle for a part of the duration of its down stroke has been put forward and extensively tested. Thus, US Patent numbers 4446754, 4519271, 4807491, 48882945 and 5095772 described pedal cranks which are in effect telescopically extensible. The degree of extension varies according to the angular position of the pedal crank with the degree of extension being controlled by a cam shaped groove, an eccentric.

In the case of some of these the disadvantage is that the pedal crank is still somewhat extended at the bottom of the crank stroke, i.e. when the crank is directed vertically downwards, this is considered to be dangerous as ground clearance is diminished. Also, one such device, as far as the applicant understands it, was marketed as an attachment to an existing cycle. In this context it created an additional danger. If the front wheel of the bicycle is turned during the down stroke of a pedal with the rear of the front wheel moving towards the pedal, a cyclist's foot could touch the front wheel or mudguard and an accident could result.

Regardless of the foregoing, the concept of the telescopic style of extension does not appear to have met with the consumer's approval.

US patent no. 5636554, on the other hand, provides a crank which is rigid for its entire maximum effective length and wherein the pedal is carried on a carrier which effectively shortens the crank for the non-power part of a revolution. The disadvantage of this is that space and ground clearance must be provided for the maximum crank length, which severely limits design flexibility.

b. Brief description of the drawings

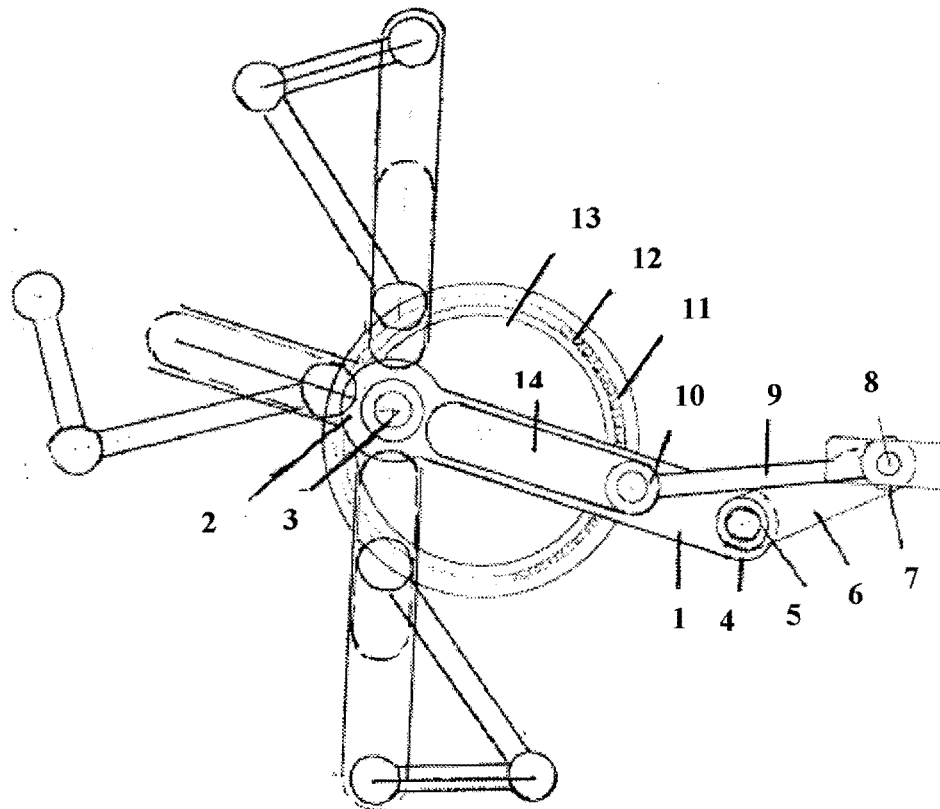

Figure 20: A schematic side elevation of a crank assembly according to the invention.

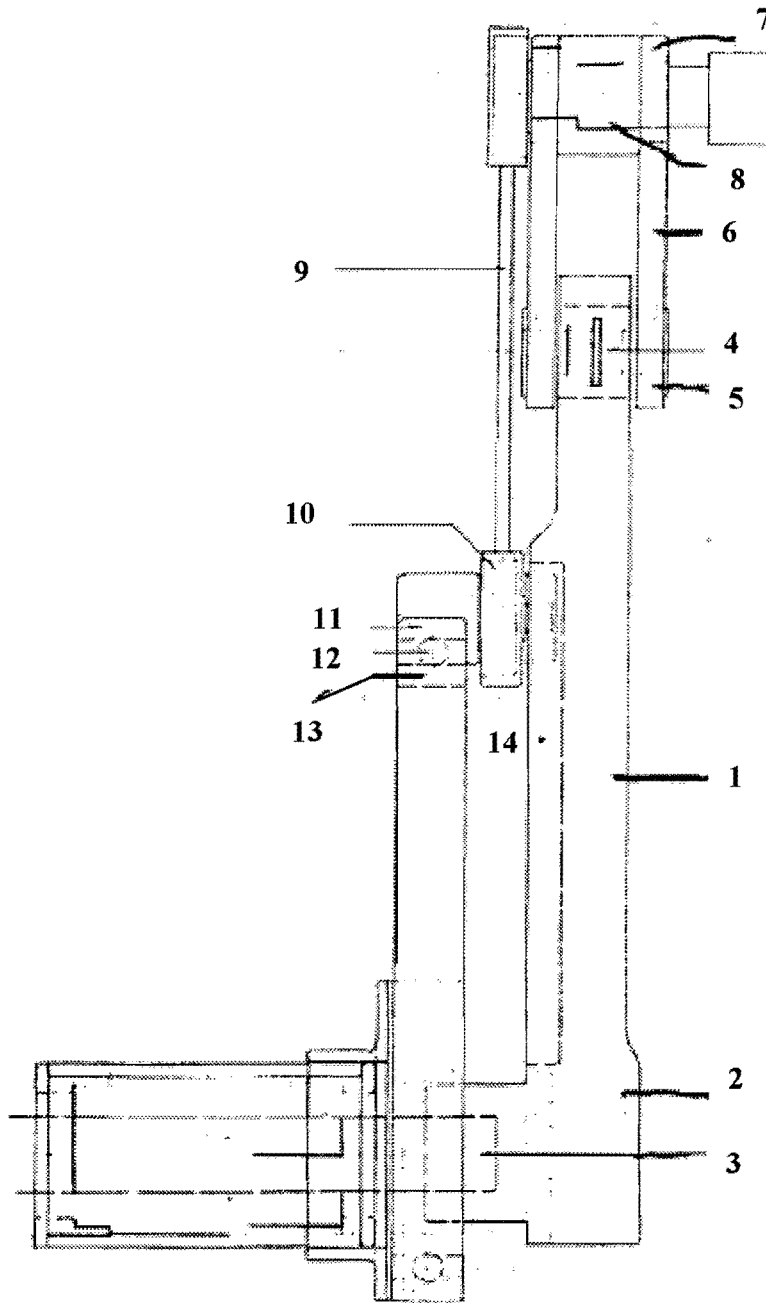

Figure 21: An enlarged end elevation thereof with the main crank in an upright position.

c. Detailed description with reference to the drawings

In the embodiment of the invention illustrated in the accompanying drawing (fig. 20), a bicycle crank assembly comprises the following:

- * A main crank member (1) adapted at its one end (2) to be fitted to the drive axle (3) of a cycle in the usual way.

To the outer end (4) of the crank is pivotally attached one end, the inner end (5), of a crank extension member (6), the free or outer end (7) of which is adapted to receive a cycle pedal axle in a socket (8).

Concentrically attached to the outer end (7) of the extension member (6) is one end, of a tie member (9) the inner end (10), which is pivotally attached to the outer side (11). On the outer race (11) is mounted a large ball race (12) the inner (13) of which is fixed relative to the cycle frame (not shown). The axis of the ball race is off-set forward relative to the axis of the drive axle (3) and slightly downwards. Simultaneously, the inner end (10) of the tie member is confined to reciprocal movement relative to the main crank member (1). A slot (14) conveniently serves as a guide for the aforementioned to take place.

As the main crank (1) rotates in a clockwise direction, the inner end (10) of the tie member will follow the path of the outer race (11) of the ball race and will then reciprocate along the length of the main crank member.

This has the effect of rotating the extension member (6) about its pivotal connection to the main crank between positions in which it is directed at least tangentially relative to the path of movement of the outer end of a main crank member. Its movement takes place also somewhat inwardly at an acute angle to the crank at the extreme part of the upstroke. On the down stroke, the extension member (6) will rotate outwardly radial beyond the end of the crank. It will then

reach a maximum position of extension relative to the main axle (3) at a position about 105 to 110 degrees downwardly relative to zero, being at a position vertically above the main axle. In these positions the extension member makes an obtuse angle with the main crank. The arrangement is such that when the bottom of the down stroke is reached the extension member is at least tangential to the path of movement of the outer end of the main crank member so that no additional road clearance is necessary in practice.

Numerous variations can be made to the embodiment of the invention described above without departing from the scope thereof. In particular, the endless path to which the inner end of the tie member is confined could be bevelled and need not be circular. It could thus be of some other shape to provide a more desirable (if possible) behaviour of the extension member relative to the main crank. In any event a large bearing may not be required and could be replaced by an endless groove in which a guided bearing or the like associated with the inner end of the tie member is controlled.

2.6 PHYSIOLOGICAL VARIABILITIES MEASURED DURING EXERCISE

2.6.1 Economy of motion

Economy of motion is the cost or oxygen uptake or energy that the body requires to produce a specific work rate, speed or movement fuel (Hawley, 1995). Energy is transported between the body and the environment in the form of heat and work. Work done by the environment on the body is negative and work done on the environment is positive (Prilutsky, 1997).

A simple method to establish differences between individuals in the economy of physical effort is to evaluate the oxygen consumption during exercise (Ericson & Nisell, 1988). This is a useful approach during steady rate exercise in which the

oxygen that is consumed during the activity closely mirrors the energy expended. It is important to note that any adjustment in training that improves the economy of effort directly translates into improved performance (McArdle et al., 1991).

Another approach to evaluate the relationship between metabolic energy expenditure and resulting mechanical output in exercise is to compute the mechanical efficiency of movement. This gives an indication of the percentage of the total energy expended that can produce external work.

$\text{Mechanical Efficiency(\%)} = \frac{\text{Actual mechanical work accomplished}}{\text{Input of energy}} \left. \vphantom{\frac{\text{Actual mechanical work accomplished}}{\text{Input of energy}}} \right\} \times 100$
--

When cycling below 80 percent maximal oxygen consumption at 60rpm, the efficiency could be accurately determined without the influence of muscle fibre composition (Timmer, 1991). The best endurance athletes are usually also the most efficient and economical. Better economy is associated with a slower rate of energy utilization, for example, muscle glycogen. The more efficient athlete will be able to cover a greater distance on the same amount of fuel, if fatigue during prolonged endurance events is associated with the depletion of body fuel (Hawley, 1995). Differences in efficiency of cyclists can be due to different parameters such as work load (Gaesser & Brooks, 1975; Seabury et al., 1977), pedalling rate (Seabury et al., 1977; McCartney et al., 1983), and saddle height (Hamley & Thomas, 1967; Nordeen-Snyder, 1977), but can also be related to the number of slow-twitch muscle fibres in the quadriceps muscles (Hawley, 1995). The above mentioned parameters can be changed in a controlled way to minimize oxygen consumption and to increase mechanical efficiency (Ericson & Nisell, 1988). In a study done by Coyle et al.(1992), the subjects with a high percentage of type 1 muscle fibres were most efficient working at either 50% or 70% of the VO₂-max than subjects with a lower percentage of slow-twitch fibres.

Studies done by Eckermann & Millahn (1967), Seabury et al. (1977) and Coast & Welch (1985) showed that the most economical pedalling rate is approximately 40-70 rpm and that it tends to increase with increasing power outputs. Hagberg et al. (1981) found that competitive cyclists working at 80% of their VO_2 -max had the most economical pedalling rate just below 90rpm. It has been suggested that cyclists could minimize peripheral muscle fatigue by pedalling at a rate that produces a higher than optimum metabolic rate, but which lowers the crank forces (Patterson & Moreno, 1989).

2.6.2 The Ventilatory Threshold

The ventilatory threshold can be defined as the point during incremental work where pulmonary ventilation begins to rise disproportionately in regard to concomitant increase in VO_2 (Schneider & Pollack, 1991). This is the point at which ventilation departs from a linear increase with work load and CO_2 production (Fox et al., 1993). For nearly thirty years the possible mechanisms underlying the ventilatory threshold has been the focus of research (Glass et al., 1997). The original theory of Wasserman and Mellroy (1964) stated that a point of tissue hypoxia was reached during progressive, incremental exercise. The ensuing anaerobic metabolism led to increased levels of CO_2 from the buffering of lactate acid, which results in an abrupt increase in ventilation (Glass et al., 1997).

The changes in V_E / VO_2 can be used to identify a person's ventilatory threshold (Glass et al., 1998). A study done by Powers et al. (1983) indicated that the measuring of oxygen uptake at the ventilatory threshold is a better predictor of performance than either VO_2 -max or economy of motion (Conley & Krahenburt, 1980; Coyle et al., 1991; Hoffmann et al., 1993; Loftin & Warren, 1994). When measuring VO_2 -max of cyclists and runners, the VO_2 - max of the cyclist will be higher when using a cycle-ergometer than on the treadmill. When measuring a runner, the VO_2 -max will be greater when using a treadmill than a cycle ergometer. However, there would be no differences in the ventilatory threshold when making

use of a treadmill or a cycle ergometer (Pechar et al., 1974; Stromme et al., 1977; Withers et al., 1981; Costa et al., 1989). This finding is also a controversial matter. Research done by Boutcher et al. (1989) and Hoffmann et al. (1993) however, proved that the ventilatory threshold is dependant on the mode of training and that the results obtained on the treadmill will differ from the results obtained on a cycle ergometer. According to Loftin & Warren (1994), the ventilatory threshold is a very important determinant of endurance cycling and running performance and is often a more important determinant than VO_2 -max.

Research done by Loftin & Warren (1994) found that a higher ventilatory threshold correlates with a faster 16.1km time trial. The reason proved to be that cyclists with higher ventilatory thresholds are able to exercise at higher percentages of their VO_2 -max and at a higher power output (Loftin & Warren, 1994).

Coyle et al. (1988) also found that cyclists with higher ventilatory thresholds possess more slow-twitch oxidative muscle fibres, a higher muscle capillary density of the vastus lateralis and have more years of experience in endurance cycling than cyclists with a lower ventilatory threshold (Coyle et al., 1991). There is also a correlation between fat percentage and ventilatory threshold. Cyclists with higher body fat percentages and skin folds, have lower ventilatory thresholds (Miller & Menfredi, 1987; Loftin & Warren, 1994). A moderate correlation was found between a derived girth ratio (thigh and calf) x (arm and chest)⁻¹ and time trial performance (speed) (Loftin & Warren, 1994). Miller & Menfredi (1987) suggested that a larger lower to upper body circumference ratio might be advantageous to cyclists as wind resistance can be reducing.

Research done by Wasserman & Mellroy (1964), Farrel & Ivey (1987), Coyle et al., 1988 and Walsh & Banister (1988), Coyle et al., 1991; Loat & Rhodes, 1993; and Loftin & Warren, 1994 proved that the lactate threshold and the ventilatory threshold occurs simultaneously and that the ventilatory threshold can be used to determine the anaerobic threshold. However, theories abound to the relation

between the ventilatory and the lactate threshold as a matter of controversy (Costa et al., 1989). According to Glass et al. (1997) the lactate and ventilatory threshold occurs at a similar VO_2 under normal muscle and liver glycogen conditions. Following glycogen depletion the lactate threshold will then “shift” to a higher VO_2 relative to the ventilatory threshold. These data indicate that lactate accumulation does not appear to be the controlling mechanism of the ventilatory threshold during progressive, incremental exercises on a cycle ergometer (Glass et al., 1997).

In order to study the relationship between the ventilatory threshold and the lactate threshold, we have to observe changes in minute ventilation and gas exchange variables, such as carbon dioxide production and the ventilatory equivalent for oxygen (V_{eBTPS} / VO_2). These variables increase linearly with an increase in workloads until the anaerobic threshold is reached. According to studies done by Fox et al (1993) it is clear that there is a definite relationship between the ventilatory threshold and the lactate threshold during exercise. As soon as the anaerobic threshold is reached, V_{eBTPS} and VCO_2 start to rise sharply. These changes also correlate with the steep rise in blood lactate concentration. The acceleration in ventilation can be due to the additional increased production of CO_2 through the buffering lactic acid which occurs in the bicarbonate system (Fox et al., 1993; Burke et al., 1994). It is important to mention that the lactate threshold and the ventilatory threshold can only be compared across studies when the exercise protocols and the methods used to determine the threshold are the same (Schneider et al, 1989).

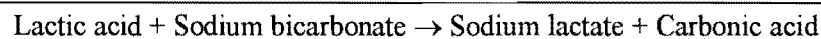

The hydrogen ion derived from lactic acid is responsible for the production of carbonic acid and CO_2 (Fox et al., 1993).

Research showed that exercise training may be beneficial for the improvement of the ability to sustain high levels of sub-maximal ventilation (Martin & Stager,

1981; Robinson & Kjeldgaard, 1982; Bender & Martin, 1985). According to McArdle et al. (1991), the ventilatory muscle endurance can be improved up to 16% by a 20 week running program, which could be the result of an increase in the aerobic enzyme levels. Ventilatory fatigue may relate to feelings of breathlessness and pulmonary discomfort because of the elevated lactate levels in untrained athletes (McArdle et al., 1991).

2.6.3 The Anaerobic / Lactate Threshold

The anaerobic threshold can be defined as the highest VO_2 beyond which an increase in blood lactate accumulation occurs (Wasserman & Mellroy, 1964; Schneider et al., 1989). It also refers to the performance at a fixed blood lactate concentration of 4mmol.l^{-1} during stepwise increasing test procedures and is accepted as a measure for the endurance capacity (Urhausen et al., 1993). The anaerobic lactate threshold merely reflects the highest exercise intensity that an athlete can sustain for a certain period of time without amounts of lactate accumulating that will limit performance. According to Powers et al. (1983), oxygen uptake measured at the anaerobic threshold is a better indication/ predictor for success in endurance activities than both $VO_2\text{-max}$ or movement economy.

The above-mentioned intensity of exercise at stable lactate levels is also known as the maximal lactate steady state. Training in this zone will optimize training adaptations and reduce the risk of over training (Coen et al., 1991; Snyder et al., 1994; Foster et al., 1995; Swensen et al., 1998).

Endurance training under the AT increases the speed and intensity at the lactate turning point and this change correlates closely with actual improvements in performance (Hawley, 1995). Studies done by Kindermann et al., (1979), Kindermann (1985), and Heck (1991), all came to the conclusion that the AT is at a blood lactate concentration of 4mmol.l^{-1} . These fixed lactate concentrations as

basis for the threshold concept, such as $4\text{mmol}\cdot\text{l}^{-1}$, represents mean steady state values which is precisely $4.02 - 4.32\text{mmol}\cdot\text{l}^{-1}$ (Urhausen et al., 1993).

According to Costa et al. (1989), the increase in lactate levels during long-term exercise is compatible with the ventilatory threshold. Jones & Ersham (1982) stated that it is also possible to keep some steadiness in blood lactate during long-term exercise at levels as high as 10mmol . Research done by Whipp & Wasserman (1972) suggest an interrelation between lactate and VO_2 drift. This increase in VO_2 might be due to blood lactate removal during exercise (Henry, 1951; Gaesser & Brooks, 1984).

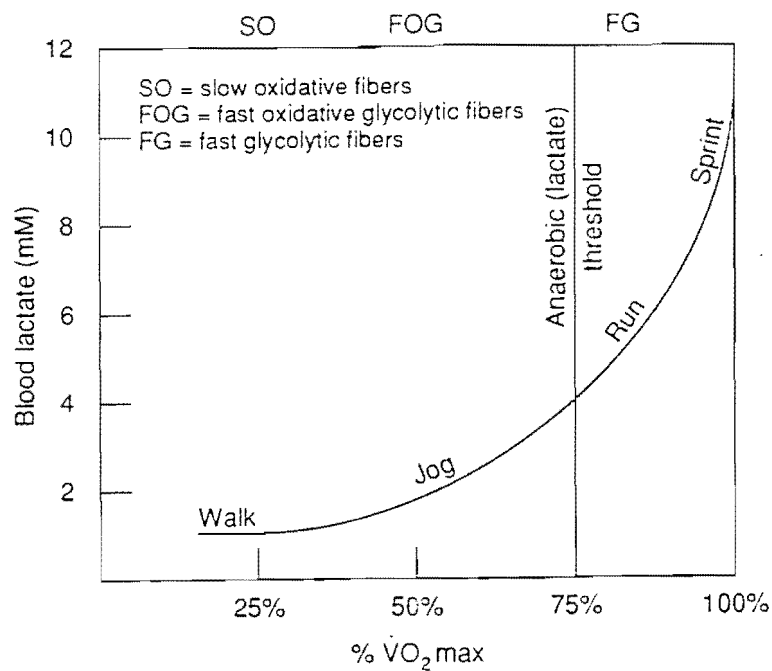

Figure 22: The anaerobic (lactate) threshold. As exercise intensity increases we begin to recruit FOG fibres. If we continue to increase intensity ($\% \text{VO}_2\text{-max}$) the FG fibres are recruited (Sharkey, 1979)

The most accurate way to determine the anaerobic threshold, is to measure an athlete's blood lactate response to various exercise intensities over time (Swensen et al., 1998). An important factor in measuring lactate concentrations, is the site where the sample is taken. Commonly used sample sites are:

- a. the forearm arteries;
- b. the forearm veins;
- c. ear lobes; and
- d. fingertips (Dassonville et al., 1998)

Arterial sampling is seldom used for field measurements, because it requires locating a relatively deep vessel for the measurement and it is associated with greater risks. There is a very high correlation in lactate concentrations from samples taken through arterialized capillary and arterial blood samples, and for this reason, capillary sampling has become increasingly used (Dassonville et al., 1998).

The increase in minute ventilation during exercise could be explained by the concept of the anaerobic threshold (Schneider et al., 1991). A study done by Wasserman et al (1973) defined AT as the VO_2 at which lactate begins to accumulate in the blood during incremental exercise. Lactic acid then diffuses into the blood at a faster rate than it can be cleared. The hydrogen ions of the lactic acid are buffered by bicarbonate and it produces excess CO_2 . This excess of CO_2 then stimulates an increased rate of ventilation. As a result of this claim that AT and ventilatory threshold occur together, many researchers use ventilatory threshold to predict AT (Davis et al., 1976; Davis et al., 1979;; Kohrt et al., 1989; Schneider et al., 1991).

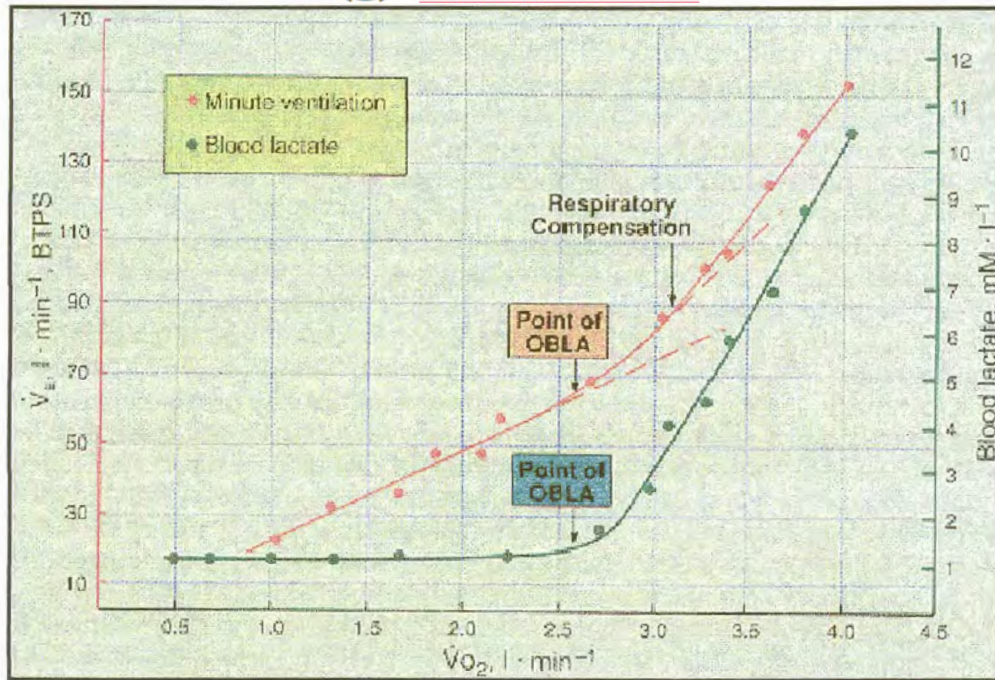

Figure 23: Pulmonary ventilation, blood lactate and oxygen consumption during incremental exercise. The dotted line represents the extrapolation of the linear relationship between V_E and VO_2 during sub-maximal exercise. The “OBLA” is the point at which blood lactate begins to accumulate above the resting value and is detected at the point at which the relationship between ventilation and oxygen consumption deviates from linearity. “Respiratory Compensation” is a further increase in ventilation to counter a fall in pH during anaerobic exercise (McArdle et al., 1991).

Several studies have documented that endurance performance is more strongly related to the metabolic rate associated with various indices of lactate kinetics during sub-maximal exercise than with exercises at maximal oxygen consumption ($VO_{2\text{-max}}$) (McLellan & Jacobs, 1989; McLellan et al., 1991). Research done by Maffulli et al. (1994) has also shown that performance relates more to sub-maximal effort measurements, such as the onset of blood lactate accumulation (OBLA 4mmol) and the anaerobic threshold (AT), than to $VO_{2\text{-max}}$. The rate of decline of $VO_{2\text{-max}}$ is much greater in older individuals than that of the anaerobic threshold. Cross sectional studies have shown that endurance trained athletes show

a significant slower rate of decline in $\text{VO}_2\text{-max}$ while they maintained or increased the percentage of $\text{VO}_2\text{-max}$ at which AT takes place (Maffulli et al., 1994).

By increasing the rate of lactate oxidation, endurance training enhances the clearance of lactate during exercise. This increased oxidative potential and the capillarization of the trained muscle groups work together with a trained-induced shift to a more oxidative lactate dehydrogenase isozyme profile to favour enhanced availability, uptake and oxidation of lactate in the trained muscle groups during exercise (McLellan & Jacobs, 1989).

According to Stegmann et al. (1981), the determination of the AT is based on a model that takes into account both diffusion and elimination of lactate during exercise. It is not necessary to reach maximum exhaustion in order to determine the AT, but the maximum blood lactate should reach at least 6mmol.l^{-1} or 5mmol.l^{-1} in well-trained athletes. If the maximum lactate concentration is lower, it would not be possible to estimate the AT accurately (Urhausen et al., 1993). The steeper increase in blood lactate above the “anaerobic threshold” indicates that lactate production exceeds its limitation from the blood (Mocellin et al., 1991).

2.6.4 Maximal Oxygen Consumption ($\text{VO}_2\text{-max}$)

$\text{VO}_2\text{-max}$ can be defined as the greatest rate at which oxygen can be consumed by an athlete during exercise under steady state conditions and is a reflection of the individual's maximum rate of aerobic energy utilization (Hawley, 1995). This is the point at which the oxygen consumption reaches a plateau and shows no further increase with additional workload (McArdle et al., 1991). Oxygen consumption rises rapidly during the first few minutes of exercise, and then between the third and the fourth minute a plateau is reached. The oxygen consumption remains relatively stable for the rest of the exercise session remaining. This flat plateau of oxygen consumption is referred to as the steady state or the steady rate and it reflects a balance between the energy required by the working muscles and the rate

of ATP production via aerobic metabolism. At this stage, oxygen consumption reactions supply the energy required for exercise. Any lactic acids produced are either oxidized or reconverted to glucose in the liver and kidneys. The lactic acid accumulation is minimal under the steady state metabolic conditions (Costa et al., 1989; McArdle et al., 1991; Swensen et al., 1998).

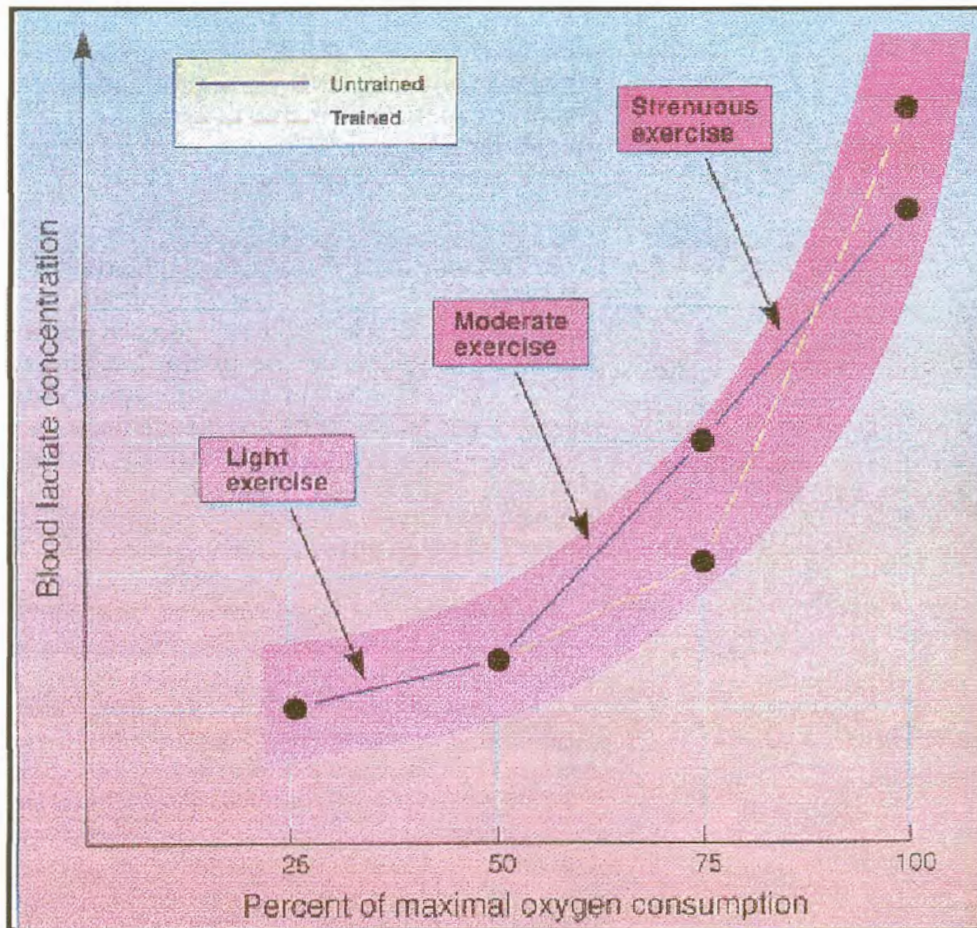

Figure 24: Increases in blood lactate concentrations at different levels of exercise expressed as a percentage of maximal oxygen consumption for trained and untrained athletes (McArdle et al., 1991).

Once the steady rate is attained, exercise could continue indefinitely if the athlete had the willpower to carry on. This is based on the premise that the steady rate of aerobic metabolism is the only factor determining one's capacity for sustained exercise. However, there are other factors to consider, for example fluid loss and

electrolyte depletion. All these factors need to be considered once the athlete has reached his steady rate (Schneider et al., 1989; Swensen et al., 1998).

Although $\text{VO}_2\text{-max}$ is a satisfactory predictor of endurance performance, individuals with similar $\text{VO}_2\text{-max}$ values can differ markedly in performance velocity (Schneider et al., 1991; Hawley, 1995). According to studies done by Schneider et al. (1989) $\text{VO}_2\text{-max}$ has been reported to have a moderate to poor correlation with the performance of tri-athletes even though $\text{VO}_2\text{-max}$ still provides a quantitative statement of an individual's capacity for energy transfer (McArdle et al., 1991). There are a number of factors that can influence the consistency and reliability of VO_2 measurements inside and outside the laboratory:

- a. the size of the working muscle groups;
- b. the magnitude of the static work component;
- c. fluctuations in ambient temperature; and
- d. the degree to which other sources of stress are present, inside and outside the laboratory.

It is interesting to note that effect of the differences between the field and the laboratory conditions decreased at or near $\text{VO}_2\text{-max}$. This implies that the $\text{VO}_2\text{-max}$ tests conducted in the laboratory and the field provide similar values (Kenny et al., 1995).

Researchers have found that the $\text{VO}_2\text{-max}$ for cycle ergometry was typically 8-11% less than the values obtained on the treadmill. These values difference decreases with endurance training (McArdle & Magel, 1970; Pechar et al., 1974; Pannier et al., 1980).

It can be assumed that the $\text{VO}_2\text{-max}$ is reached when at least two of the following criteria were satisfied:

- i. mean RQ ≥ 1.10 ;
- ii. heart rate within 10 beats of the age predicted maximum; or; and
- iii. lactate concentration $\geq 10\text{mM}$ (Capelli et al., 1997).

Costa et al. (1989) reported that the oxygen consumption in long term exercises at loads above 60% of the VO_2 max, continue to increase instead of keeping a steady-state. This continuous increase in oxygen consumption, is referred to as the VO_2 drift. Theories suggested that this VO_2 drift could be the consequence of lactic acid removal or exercise-induced hyper-thermia (Costa et al., 1989; Henry, 1951; Davis, 1985).

In research studies done by Loftin & Warren (1994) they suggested that the maximum oxygen consumption average 57ml/kg/min^{-1} in non-elite competitive cyclists and that the VO_2 -max values of national cyclists is average from 65 to 70ml/kg/min^{-1} . VO_2 -max is not spared the effects of aging on the body (Kasch et al., 1988; Schulman et al, 1989). In girls the average VO_2 -max peaks at 14 years and begins to decline thereafter. At the age of 14 years the difference in VO_2 -max between males and females is 25% and will increase to reach a difference of 50% at the age of 16 years. The most common explanation for the difference in relative VO_2 -max between boys and girls as they advance in age is the relative greater accumulation of fat in girls. After the age of 25 years, the VO_2 -max declines steadily at about 1% per year up to the age of 55 years, where it is about 27% below the values reported for 20-year-olds (Kasch et al., 1988; McArdle et al., 1991).

2.6.5 Heart Rate (HR)

Heart rate can be defined as the frequency of contraction of the heart and is often inferred from pulse rate (expansion of artery resulting from beat of heart) (Schulman & Gerstenblith, 1989; Sharkey, 1979)

Each person has a resting and a maximal heart rate which are influenced by both age and activity level. The resting heart rate is highly influenced by the person's activity level. The more one exercises and the fitness level improves, the more the resting heart rate will decline. The resting heart rate is thus a good way to monitor

improvement in fitness (Schulman & Gerstenblith, 1989; McArdle et al., 1991). The maximal rate is the highest possible rate a person can reach and is also influenced by fitness and age (Davis, 1985; Sharkey, 1990; McArdle et al., 1991).

Table 2: Age and fitness adjusted maximal heart rates (Sharkey, 1990).

Predicted maximal heart rate			
Age	Below average fitness	Average fitness	Above average fitness
20	201	201	196
25	195	197	194
30	190	193	191
35	184	190	188
40	179	186	186
45	174	183	183
50	168	179	180
55	163	176	178
60	158	172	175
65	152	169	173
70	147	165	170

Heart rate is used to determine a person's training zone. One way to determine training heart rate, is by using Karvonen's Formula:

$$\begin{aligned}
 \text{HR} &= [70\% \times (\text{maximal HR} - \text{resting HR})] + \text{resting HR} \\
 &= [70\% \times (170-70)] + 70 \\
 &= \mathbf{140 \text{ beats/min}}
 \end{aligned}$$

This formula allows the calculation of a training heart rate percentage equivalent to the percentage VO₂-max. It also adjusts for differences in resting and maximal heart rates (Davis, 1985; Sharkey, 1990).

An increase in heart rate also causes an increase in cardiac output (Q). According to Berg (1984), heart rate is the most consistent factor involved with the increase in Q and $\dot{V}O_2$ during exercise. Heart rate can also be used to predict $\dot{V}O_{2\text{-max}}$ by a standardized regimen of sub- maximal exercise performed on a bicycle or treadmill, named extrapolation relationship between heart rate and oxygen consumption at various exercise intensities (Schulman & Gerstenblith, 1989). The slope of this line is then a reflection of the individual's aerobic fitness. The $\dot{V}O_{2\text{-max}}$ can then be estimated by drawing a straight line through various sub- maximal points that relate to heart rate and oxygen consumption. This line is then extended to the same assumed maximum heart rate for the particular age group (Davis, 1985; McArdle et al., 1991).

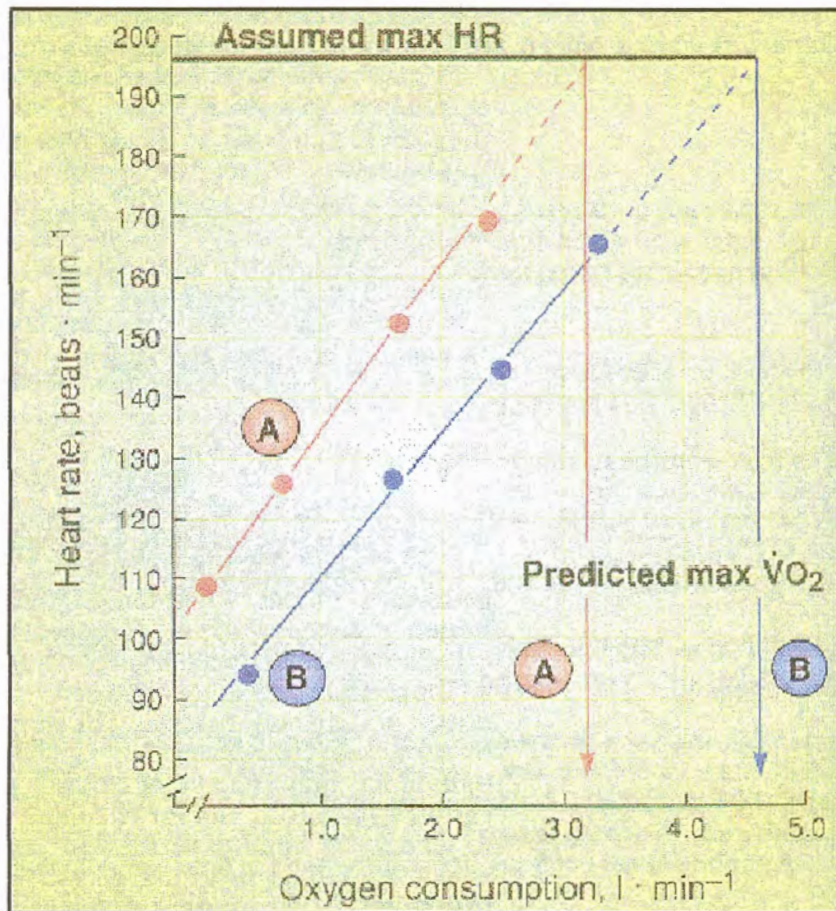

Figure 25: Application of the linear relationship between sub- maximal heart rate and oxygen consumption to predict $\dot{V}O_{2\text{-max}}$ (McArdle et al., 1991).

The accuracy of predicting VO_2 -max from the heart rate during sub- maximal exercise, is limited by the following:

- a. the linearity of heart rate - oxygen consumption relationship: The heart rate - oxygen consumption line can curve or asymptotes at heavier work loads which will indicate a larger than expected increase in oxygen consumption per unit heart rate (Davis, 1985);
- b. similar maximum heart rates are used for all subjects;
- c. a constant economy or mechanical efficiency are assumed for all subjects during all stages of exercise; and
- d. day-to-day variation in heart rate: Even under highly standardized conditions, the heart rate may vary with average of 5 beats per minute (McArdle et al., 1991).

2.6.6 Respiratory Coefficient (RQ):

The respiratory coefficient is the quantity of carbon dioxide produced in relation to the amount of oxygen consumed. The RQ during exercise is dependant on the substrate metabolized (Pannier et al., 1980; McArdle et al., 1991). According to Astrand & Rodahl (1986) the RQ is useful during rest and sub- maximal aerobic exercise, because it serves as a convenient guide to the nutrient mixture being catabolized for energy. To estimate the body's heat production, one must know the RQ and the amount of oxygen consumed because the caloric equivalent for oxygen differs depending on the nutrient oxidized (Pannier et al., 1980; Van der Plas, 1989).

When the RQ is 1:1, all the energy comes from carbohydrates. If the RQ is 0.7, the energy used will come from the fat stores. Any intermediate ratio allows the

physiologist to determine how much fat or carbohydrates are being burned (Van der Plas, 1989).

2.6.7 Respiratory Rate (RR):

Respiration rate, also known as respiration frequency, refers to the number of breaths that we take in per minute (Fox et al., 1993). Respiration rate is used to determine minute ventilation (Pannier et al., 1980; Fox et al., 1993).

2.6.8 Minute Ventilation (V_E):

The term minute ventilation refers to the amount of air, which is either inhaled or exhaled in one minute. It mostly refers to the amount expired (v_E) than the amount inspired (V_I) (Hagberg et al., 1978; Fox et al., 1993).

To determine minute ventilation, you have to know the following:

- a. tidal Volume (TV): the amount of air we exhale in one minute; and
- b. respiratory Rate (RR): how many breaths we take in one minute.

$V_E = TV \times RR$

(Fox et al., 1993)

During breathing at rest, the average breathing rate can be 12 breaths per minute and the TV about 0,5 litres of air per breath. Under these conditions, the minute ventilation will be 6 litre:

$$\begin{array}{rclclcl}
 V_E & = & RR & \times & TV \\
 6 \text{ litres} \cdot \text{min}^{-1} & = & 12 & \times & 0.5
 \end{array}$$

(McArdle et al., 1991)

An increase in minute ventilation can either be the result of an increase in depth or the rate of breathing, or an increase in both. During strenuous exercise the breathing rate of young adults usually rises to 35 to 45 beats per minute, although rates as high as 60 to 70 beats per minutes can be found with elite athletes during maximal exercise. During exercise the TV usually increases to 2,0 litres and larger. Thus, with an increase in RR and TV, the minute ventilation can easily reach 100 litres or about 17 times the resting amount. In well-conditioned athletes, the ventilation can increase to 160 litres per minute during maximal exercise (Hagberg et al., 1978; McArdle et al., 1991).

2.6.9 Tidal Volume (TV)

The volume of air moved during inspiration or expiration of each breathing phase, is called the tidal volume (TV). The TV usually ranges between 0.4 and 1.0 litres air per breath during resting conditions (Hagberg et al., 1978). The tidal volume increases with exercise, but will rarely exceed 55% to 65% of the vital capacity for both trained and untrained athletes (McArdle et al., 1991).

Table 3: An inter-relationship between tidal volume, breathing rate and minute ventilation (McArdle et al., 1991).

Condition	Tidal Volume	x	Breathing Rate	=	Minute
Ventilation	(ml)		(breaths.min ⁻¹)		(ml.min ⁻¹)
Shallow breathing	150		40		6000
Normal breathing	500		12		6000
Deep breathing	1000		6		6000

2.6.10 Metabolic Equivalent (MET):

The word MET stands for “Metabolic Equivalent”. One MET can be defined as a standard quantity of oxygen required for maintenance of life under quiet, resting conditions (Conley & Krahenburt, 1980; Coyle et al., 1991; Fox et al., 1993). 1 MET is equal to 3,5 ml. oxygen consumed per kilogram of body weight per minute and is written as 3,5 ml./kg·min⁻¹. This constant value can be used to estimate a person’s resting oxygen consumption rate. For example, a person weighing 80 kg will have a resting VO₂ of 280 ml O₂/min. (3.5 ml./kg·min⁻¹ · x 80 kg) (Conley & Krahenburt, 1980; Fox et al.,1993).

According to McArdle et al. (1991) and Sharkey (1979), a MET can also be defined as a multiple of the resting metabolic rate. 1 MET is equivalent to the resting oxygen consumption of approximately 250ml per minute for men and 200 ml per minute for woman. To do work at 2 METS, a male will then require twice the resting metabolism which would be more or less 500ml of oxygen per minute (Coyle et al., 1991; McArdle et al., 1991).

MET’s can be used to measure exercise intensity.

Table 4: Measures of exercise intensity (Sharkey, 1990)

Intensity	Heart rate (bpm)	VO₂ (L/min)	Cal/min	METs
Light	100	1.0	5	4.0
Moderate	135	2.0	10	8.1
Heavy	170	3.0	15	12.2

* 1 L oxygen is equivalent to 5 cal/min

2.6.11 Breathing / Ventilatory Equivalent (V_E / VO_2)

The ventilatory equivalent refers to the ratio of minute ventilation to oxygen consumption and can be used as indicator of the ventilatory threshold. This ratio is usually maintained at about 25 to 1, in other words 25 litres of air breathed per litre oxygen consumed (Rowland et al., 1988; McArdle et al., 1991). During sub-maximal exercise this value is about 55% of the maximal oxygen uptake. The ventilatory equivalent is progressively higher in younger children and averages about 32 litres in children 6 years of age (Rowland & Green, 1988).

2.7 CYCLING INJURIES

Since cycling became very popular at the turn of the century, the sports medicine physician has been confronted with a “rash” of cycling injuries. Together with an increase interest in fitness, riders started to participate in more intensive training programmes and it increased the appearance of overuse injuries (Fu & Stone, 1994).

2.7.1 Common cycling injuries:

The most common injury in cycling is road rash. It is a frictional injury which occurs when the rider falls on a hard surface, such as asphalt. It is important to clean the wound properly and to remove all the foreign materials, including gravel, dirt, etc. Application of Xylocaine prior to cleaning of the wound gives good anesthesia for the steps that follow. Most of these injuries occur on elbows, shoulders, hips and knees which require movement of the limb and therefore it is ideal to use Flexnet or Tubigauze elastic circumferential dressings (fig. 26) to hold the dressings in position for the rest of the race.



Figure 26: The use of flexnet to hold dressings in place (Fu & Stone, 1994)

Protection against abrasions can be afforded by wearing more resilient clothing with long sleeves and legs. Other common injuries associated with cycling accidents are lacerations, contusions, fractures and closed head injuries (Fu & Stone, 1994)

2.7.2 Overuse injuries in Cyclists

Over training occurs when your body is pushed over its limits in your efforts to raise its limits. Over training is common, but the symptoms are not always easy to recognize (Roy & Irvin, 1983; Peterson & Renstrom, 1994).

Symptoms, which serve as an indication of over training, are the following:

- a. unusual increase in your pulse rate when relaxed;
- b. sore legs and heavy breathing during exercise and other activities such as

- a. unusual increase in your pulse rate when relaxed;
- b. sore legs and heavy breathing during exercise and other activities such as climbing stairs;
- c. excessive thirst;
- d. insomnia; and
- e. continual tiredness, apathy and poor appetite.

(Roy & Irvin, 1983; Beneke et al., 1989; Peterson & Renstrom, 1994)

Saddle sores are a very common and irritating problem when exercising a lot. Saddle sores present, in their mildest form, as chafing of the buttock of the novice rider or at more advanced riders at the beginning of the cycling season. Padded cycling pants, gel seats and occasional sitz baths will handle the more advanced cases (Kendall et al., 1983)

Nerve compression syndrome of the hands are complaints that we often get with recreational and competitive cyclists. Ulnar nerve compression at Guyon's canal produces parasthesia and numbness over the first finger and over the ulnar half of the ring finger. Carpal tunnel syndrome gives the typical distribution of parasthesia of the remaining fingers of the hand. (Roy & Irvin, 1983; Fu & Stone, 1994).

The genital area is another anatomical site affected by nerve pressure problems. If the seats are too upwardly tilted or the rider sits in a forward position, the pressure on the penile and pudendal nerve increases. The numbness can last for a considerable period of time, but will resolve with rest from this riding position. To prevent this numbness, it may be necessary to wear padded cycling shorts, improve proper seat positioning and use an innovative seat that does not have the forward protruding horn (Fu & Stone, 1994; Peterson & Renstrom, 1994).

Even though cycling doesn't exercise the muscle eccentric there are still episodes of tendinosis during the initial part of training with heavy training loads. Tendonitis occurs solely in the lower extremities and is usually secondary to high mileage or

increased stress resulting from pushing too big a gear (Peterson & Renstrom, 1994). A friction-type injury of the iliotibial band can occur where it crosses the greater trochanter at the hip or the lateral femoral condyle. In this injury, treatment is directed at reducing the inflammation by rest, ice, anti-inflammatory medications and also physical therapy modalities. When the inflammation is reduced, a program of aggressive stretching exercises is started to improve the flexibility of the band at the sites of friction (Roy & Irvin, 1983; Fu & Stone, 1994).

Achillis tendonitis is common amongst competitive riders who sprint or climb hills in a standing position. In these cases, the Achillis tendon is loaded more than when cycling in a seated position. Also, toe clips that are too small and do not allow the rider to insert his foot far enough into the clips, also produce more stress at the Achilles tendon and the gastrocnemius. Rest, ice, anti-inflammatory, heel lifts and taping of the Achilles tendon will help in arresting this malady (Fu & Stone, 1994; Peterson & Renstrom, 1994).

The biggest contributor to patellofemoral problems is training error that includes too many miles, too fast. Both interval work and training on hills overload the patella. Keeping a good cadence between 90 and 110 rpm is one of the most important things a cyclist must do in order to prevent patellofemoral problems. It is also important to follow a training programme, which reduces patellar stresses and that reeducate the vastus medialis obliquus. This can be done by an endurance program which emphasize mini squats. The McConnel technique for patellar taping as well as the use of less restrictive patellar braces can be helpful.(Fu & Stone, 1994).

2.7.3 The role of cycling in rehabilitation

The real-time force feedback from each pedal can be used to correct asymmetries in force production common in persons with post stroke hemiplegia (Brown et al.,

1994). Feedback during cycling can also be used to increase the range of motion and to correct dynamic ankle motion deficiencies that may occur when people avoid using the injured ankle while recovering from an ankle injury (Pierson-Carey et al., 1997).

2.8 THE TRAINING PROGRAM

The purpose of different types of training is to stress the metabolic systems and to improve the different aspects of cycling. Table 5 shows the approximate percentage of contribution to the energy systems by each of the eight training methods described by Burke (1986).

Table 5: The approximate percentage of contribution to the energy systems by each of the eight training methods described by Burke (1986).

Type of training	ATP-PC & LA (%)	LA & Aerobic (%)	Aerobic capacity (%)
Sprint training	90	6	4
Acceleration sprints	90	5	5
Set sprints	30	50	20
Intervals	10-30	30-50	20-60
Speed play (fartlek)	20	40	40
Repetition riding	10	50	40
Continuous fast riding	2	13	85
Continuous slow riding		5	95

a. Sprint Training:

These exercises focus purely on speed and it means riding against maximum speed, an all-out effort, for 75 to 100 meters with relatively long rest intervals. Sprint

training requires repetition of short sprints in preparation for competitive rides (Kendall et al., 1983; Burke, 1986).

b. Acceleration Sprints:

These exercises involve a gradual increase from a slow steady pace to an all-out effort. It can be divided in three parts: one-third easy effort, one-third medium hard effort and one-third maximum effort, for about 200 to 250 m. If enough repetitions are used, this type of exercise will improve both speed and endurance (Burke, 1986; Chu, 1995)

c. Set Sprints:

This includes a set of sprints followed by a rest period for recovery and will develop speed and endurance. The following programme is an example of a typical set sprint programme:

Set 1: Sprint 75m, medium pace for 75m, sprint 75m, very slow for 75m for recovery prior to the next set

Set 2: Sprint 100m, medium pace for 100m, sprint 100m, slow for 100m

Set 3: Sprint 150m, medium pace for 150m, sprint 150m, slow for 150m.

* Repeat the programme once totally recovered and ready to sprint again*
(Burke, 1986; Chu, 1995).

d. Intervals:

Interval training involves riding a series of repeated efforts over a given distance with a controlled number of rest intervals in between the sprints. The rest intervals will allow the rider to recover partially to normal (Kendall et al., 1983; Chu, 1995)

e. Speed Play:

Speed play, also known as fartlek, means riding fairly long distances using a variety of speeds. This can be done on velodrome or on the road. When used properly, it will improve both speed and endurance and it is also psychologically stimulating (Kendall et al, 1983; Burke, 1986).

f. Repetition Riding:

In this exercise, the cyclist rides a set distance at a fast speed, close to race pace. The recovery time in between the rides should allow almost complete recovery. The repetition rides are usually done over longer distances than interval training (1000 - 2000m) (Burke, 1986; Chu, 1995).

g. Continuous Slow Riding:

The cyclist ride long distances at a speed slower than race pace, and is also known as LSD-training ("Long Slow Distance"). The distance covered must be related to the racer's event. The heart rate must be kept average 150 rpm and it is not necessary to keep record of the time. These exercises show great increase in aerobic endurance (Burke, 1986).

h. Continuous Fast Riding:

It differs from slow riding in speed and distance. The distance is shorter than those from the slow ride, but longer than the race distance. This type of exercise is good for endurance training and it gradually conditions the body to the pace race (Burke, 1986; Chu, 1995).

It is very important to plan your program for the year in advance. With good planning it is possible to peak twice a year. Peaking is an art itself. You need to rid of the distractions so that top physical condition coincides with mental determination. The following programme is an example of a racer's annual programme:

- * First preparation period: December, January and February
- * First peak: March, April and May
- * Second preparation period: Partially off-season - June, July and August
- * Second peak: September, October and November

(Beneke et al., 1989; Chu, 1995)

2.9 FLEXIBILITY EXERCISES FOR CYCLISTS

Stretching before and after exercise will help to minimize soreness in the lower back and the legs. All the stretches should be done in a slow, static manner with no ballistic movements. Each stretch should be hold for the count of 15 to 20 seconds (McArdle & Magel, 1970; Burkett & Darst, 1987).

a. Hamstrings and lower back: From a standing position with the legs slightly flexed, bend forward and let your arms and head hang down (Burkett & Darst, 1987; McArdle et al., 1991).

b. Quadriceps and knee: From a standing position, grab the front of the ankle and pull the heel up toward the buttocks. Be careful not to arch the back (Conley, 1996).

c. Groin and hamstrings: From a standing position, place one leg forward at about chest height on a secure object with the top of the leg flexed and pointed straight ahead. Lean forward towards the foot until you can feel the stretch (Burkett & Darst., 1987, Conley, 1996).

- d. Calf:** Stand with the front part of the foot on a step. Push the heels down as far as possible without leaning forward while keeping the legs straight, (Kendall et al., 1983; Conley, 1996).
- e. Lower back and groin:** Lie flat on your back. With the one leg kept straight, pull the other knee to the chest until you feel the stretch (Burke, 1986; Burkett & Darst, 1987).
- f. Neck and upper back:** Lie flat on your back with the knees flexed. Put your hands behind your head and pull the head and upper back off the floor (Burkett & Darst, 1987).
- g. Back and hips:** In a sitting position, keep the one leg straight and place the other leg in a bent position over the straight one with the foot outside the opposite knee. Twist the trunk and the upper body towards the bent leg and hook the elbow above the knee (McArdle & Magel, 1970, Conley, 1996).
- h. Hamstrings:** In a sitting position, spread the legs about two feet apart and slowly bend forward towards the foot. Push the chest towards the knee and the hands towards the ankle (Burkett & Darst, 1987; Conley, 1996).
- i. Quadriceps Stretch:** While lying on the stomach, grab the ankle of the one leg. Pull the heel of the foot towards the gluteal region. To increase the intensity of the stretch, lift the thigh off the floor until you feel the tightness (Kendall et al., 1983; Burke, 1986; Conley, 1996).