

**SHEAR BOND STRENGTH, MICROLEAKAGE
AND ANTI - BACTERIAL PROPERTIES OF SELF-
ETCHING BONDING SYSTEMS**

Paul Dieter Brandt

Submitted in partial fulfilment of the degree

MSc (Odont)

In

the Department of Odontology, School of Dentistry,

University of Pretoria

2009

SHEAR BOND STRENGTH, MICROLEAKAGE AND ANTI - BACTERIAL PROPERTIES OF SELF- ETCHING BONDING SYSTEMS

by

Paul Dieter Brandt

Supervisor: **Prof. F.A. de Wet**
Department of Odontology
School of Dentistry, University of Pretoria

DECLARATION

I, Paul Dieter Brandt, hereby declare that this dissertation, submitted by me in partial fulfilment of the requirements for the degree MSc (Odont) at the University of Pretoria, South Africa, has not been submitted for a degree at any other University.

.....

P.D. Brandt

SUMMARY

Self-etching dentine bonding agents are a recent addition to the choice of bonding agents which a clinician has available to bond resin restorations to tooth structure. The so-called ‘traditional’, total-etch fourth and fifth generation dentine bonding agents have proven their clinical abilities and the question now remains whether these ‘new’ self-etching dentine bonding agents will clinically perform as well as the ‘proven’ total-etch dentine bonding agents.

For the purpose of this dissertation the author completed three research projects which were performed to evaluate the efficacy of a selection of dentine bonding agents and then used the results to compare some properties (shear bond strength, microleakage, and anti-bacterial properties) of total-etch dentine bonding agents with some self-etching dentine bonding agents. All discussions will focus on the three dentine bonding agent properties evaluated by the three research projects performed.

The three specific aims of this study were:

- To compare the dentine shear bond strength of a selection of self-etching dentine bonding agents with that of a total-etch dentine bonding agent control.
- To compare dentine and enamel microleakage values of a selection of self-etching bonding agents with that of a total-etch dentine bonding agent control.
- To evaluate the possible anti-bacterial properties of a selection of dentine bonding agents, with focus placed on the self-etching dentine bonding agent ABF^b (Clearfil Protect Bond).

The studies performed by the author achieved comparative/similar results to some studies described in the literature but it is clear from the literature that some studies provide conflicting results, especially leakage of enamel margins when using self-etching bonding agents.

Taking into consideration the limitations of the three studies performed, it can be concluded that as far as the three evaluated properties of self-etching dentine bonding agents are concerned, they should prove to be acceptable clinical alternatives for use in place of total-etch dentine bonding agents.

Table of Contents

1. Purpose of the Study.....	8
2. Introduction.....	10
2.1 History and Development of Bonding Agents.....	10
2.2 Bonding Agent Classification Systems.....	12
2.3 Current Bonding Agents.....	13
• Fourth Generation Dentine Bonding Agents.....	13
• Fifth Generation Dentine Bonding Agents.....	17
• Sixth Generation Dentine Bonding Agents.....	18
• Seventh Generation Dentine Bonding Agents.....	19
2.4 Properties of the ‘Ideal’ Dentine Bonding Agent	21
2.5 Testing of Dentine Bonding Agent Properties.....	21
2.5.1 Testing of Bond Strength to Tooth Structure.....	22
2.5.2 Testing of Microleakage.....	32
2.5.3 Testing of Anti-bacterial Properties.....	38
• Growth Media and Bacteria (Test Organisms).....	39
• Chlorhexidine.....	40
• MDPB (12-methacryloyloxydodecylpyridinium bromide).....	40
3. Materials & Methods.....	42
3.1 <i>In-vitro</i> Shear Bond Strength Evaluation.....	42
3.2 <i>In-vitro</i> Microleakage Evaluation.....	45
3.3 <i>In-vitro</i> Anti-Bacterial Efficacy.....	50
4. Results.....	54
4.1 <i>In-vitro</i> Shear Bond Strength Evaluation.....	54



4.2 <i>In-vitro</i> Microleakage Evaluation.....	55
4.3 <i>In-vitro</i> Anti-Bacterial Efficacy.....	56
5. Discussion.....	59
5.1 <i>In-vitro</i> Shear Bond Strength Evaluation.....	59
5.2 <i>In-vitro</i> Microleakage Evaluation.....	64
5.3 <i>In-vitro</i> Anti-Bacterial Efficacy.....	69
6. Conclusions.....	72
6.1 <i>In-vitro</i> Shear Bond Strength Evaluation.....	72
6.2 <i>In-vitro</i> Microleakage Evaluation.....	73
6.3 <i>In-vitro</i> Anti-Bacterial Efficacy.....	73
6.4 General Conclusions.....	74
7. References.....	75
8. List of Tables.....	101
9. List of Figures.....	103
10. List of Materials and Equipment Manufacturers.....	105
11. Acknowledgements.....	108

1. Purpose of the Study

Self-etching dentine bonding agents are a recent addition to the choice of bonding agents which a clinician has available to bond resin restorations to tooth structure. The so-called ‘traditional’, total-etch fourth and fifth generation dentine bonding agents have proven their clinical abilities and the question now remains whether these ‘new’ self-etching dentine bonding agents will clinically perform as well as the ‘proven’ total-etch dentine bonding agents.

For the purpose of this dissertation the author completed three research projects which were performed to evaluate the efficacy of a selection of dentine bonding agents and then used the results to compare some properties (shear bond strength, microleakage, and anti-bacterial properties) of total-etch dentine bonding agents with some self-etching dentine bonding agents. All discussions will focus on the three dentine bonding agent properties evaluated by the three research projects performed.

The three specific aims of this study were:

- To compare the dentine shear bond strength of a selection of self-etching dentine bonding agents with that of a total-etch dentine bonding agent control.
- To compare dentine and enamel microleakage values of a selection of self-etching bonding agents with that of a total-etch dentine bonding agent control.
- To evaluate the possible anti-bacterial properties of a selection of dentine bonding agents, with focus placed on the self-etching dentine bonding agent ABF^b (Clearfil Protect Bond).

The hypothesis to be tested was, as far as the three properties tested were concerned, that self-etching dentine bonding agents would compare favourably to total-etching dentine bonding agents. Therefore, dentists could justifiably be able to use self-etching dentine bonding agents as suitable alternatives to total-etching dentine bonding agents.

2. Introduction

2.1. History and Development of Bonding Agents

In 1949 Oskar Hagger, a Swiss dentist/chemist, developed the first system to bond acrylic resin to dentine. Hagger, a chemist who worked for the DeTrey/Amalgamated Dental Company, developed a product called Sevriton Cavity Seal. This product was acidic in nature and interacted with the tooth structure on a molecular level. These acrylic materials were indicated for the restoration of anterior teeth but later proved to be unacceptable because of leakage.¹ However, 50 years later, ‘acidic’ products are again being investigated and researched as ‘self-etching’ dentine bonding agents and self-etching cements. According to Söderholm (2007),² Oskar Hagger could be seen as the true “Father of Modern Dental Adhesives”.

In 1955 Buonocore proposed that acids could be used to alter the surface of enamel to “render it more receptive to adhesion”.³ This laid the early foundation for adhesive restorative dentistry and preventive dentistry as we know it today. His investigations were originally based on the industrial use of phosphoric acid to improve adhesion of paints and acrylic coatings to metal surfaces. He also determined that acrylic resin could be bonded to human enamel after etching (conditioning) it with 85% phosphoric acid for a period of 30 seconds.³

Buonocore *et. al.* (1968),⁴ was also the first to suggest that the formation of resin tags was responsible for adhesion to acid-etched enamel. In 1967 Gwinnett and Matsui describes the adhesion mechanism in more detail, focussing on resin tag formation in phosphoric-acid-etched enamel.⁵

The first bonding to dentine is described by Buonocore *et. al.* (1956).⁶ The ‘bonding resin’ contained glycerophosphoric acid dimethacrylate which could bond to hydrochloric acid-etched dentinal surfaces. However, it was found that immersion in water diminished the bond strength substantially.⁶ The next important step in bonding agent development took place in 1962 when Bowen synthesized N-phenylglycine glycidyl methacrylate (NPG-GMA), a “surface-active co-monomer” which could, theoretically, provide water resistant bonding of resin to dentinal calcium.⁷ However, commercial products subsequently developed (based on his formulation) provided poor clinical results.^{8,9}

During the 1980’s a *second generation* of bonding agents were developed. Most of these products were halophosphorous esters of unfilled resins such as bisphenol A-glycidyl methacrylate (Bis-GMA) or hydroxyethyl methacrylate (HEMA). The bonding mechanism involved both surface wetting and ionic interaction between the phosphate groups and dentinal calcium.^{10,11} However, the shear bond strengths (ranging from 1-10 MPa) were too weak to counteract the polymerization shrinkage of composite resins.^{12,13} These ‘*second generation*’ bonds were prone to hydrolysis, with subsequent gap formation and microleakage, especially at dentine and cementum margins.^{14,15} As the dentine was not etched when using these bonding agents, a major reason for the poor performance of these bonding agents is the fact that bonding took place to the smear layer rather than to the dentine itself.¹⁶

At the end of the 80’s the so-called *third-generation* bonding agents were developed. When these bonding agents were used they either modified or completely removed

the smear layer in order to allow resin penetration into the underlying dentine.¹⁷⁻¹⁹ Dentine shear bond strengths of products such as Scotchbond 2 (3M Dental)*, Gluma (Bayer), Syntac (Vivadent) and XR Bond (Kerr) were usually greater than those of *second generation* products and some even approached the average bond strengths of resin to etched enamel. However, their performance was still unpredictable and values varied substantially among different studies, and also with-in studies.²⁰⁻²⁴ However, these *third-generation* products were shown to be an improvement on previous generations. Marginal leakage at dentine and cementum margins was less, and (for the first time) some reinforcement of tooth structure was possible. Over-all clinical retention was also improved.²⁵⁻²⁸

The concept of the “total-etch” technique became a reality in 1979 when Fusayama *et. al.* described the simultaneously etching of dentine and enamel.²⁹ Dentine etching subsequently became a fairly common practise in Japan, but it took 10 years before total-etching gained acceptance in the United States.^{30,31}

2.2. Bonding Agent Classification Systems

Various classification systems are described in the literature. For the purpose of this dissertation it was decided to use the most often used classification system whereby bonding agents are divided into ‘Generations’. The first three generations are described above as part of Section 2.1 above.

* **Now called 3M ESPE**

Even with-in the ‘Generations’ classification some variations have been described.

There are also other classification systems used and recommended.

One of many examples of an alternative classification system according to type of etching technique is shown below (Fig 1).³²

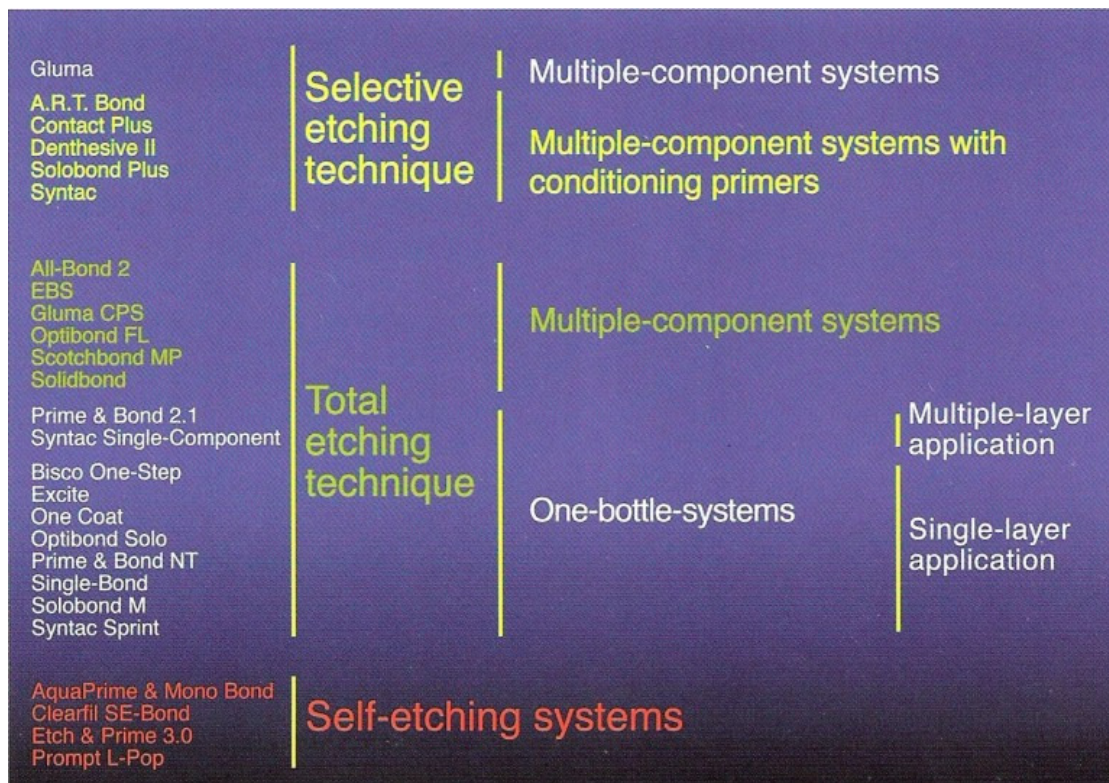

Fig. 1: Bonding agent classification according to type of etching technique used.

(According to Dr. U. Blunck, Humboldt University, Charité Berlin, Germany)³²

2.3. Current Bonding Systems

Fourth Generation Dentine Bonding Agents

Often referred to as ‘traditional’ dentine bonding agents, or ‘two bottle, total-etch bonding agents’, ‘three-step, total-etch’ or ‘three-step etch and rinse’ dentine bonding

agents. These ‘two bottle’ total-etch dentine bonding agents are still widely used in private practise. One bottle contains the ‘Primer’ and the other bottle contains the ‘Adhesive’. One of the best known examples and proven ‘golden standard’ which is often used in research projects, is Scotchbond Multipurpose Plus^{a **}.³³⁻³⁷ Scotchbond Multipurpose Plus^a is also used as control in the research performed for this study, in both the shear bond strength and microleakage studies.

The use of these dentine bonding agents involves a 35-37% phosphoric acid-etching step that completely removes the smear layer. According to Kugel & Ferrari (2000),³⁸ the first research on this generation was done by Fusayama and his co-workers who tried to simplify bonding to enamel and dentine by etching the preparation with 40% phosphoric acid. At that stage they did not realise that their recommended procedure in fact over-etched the dentine, something which subsequently led to a collapse of exposed collagen fibers. In 1982, Nakabayashi and co-workers³⁹ reported the formation of the so-called ‘hybrid layer’. They defined this layer as “the structure formed in dental hard tissues (enamel, dentine, cementum) by demineralization of the surface and the subsequent subsurface penetration of monomers and its polymerization”.³⁹

Currently, with the ‘total-etch’ technique (used with both fourth and fifth generation products) both the enamel and dentine is etched.^{40,41} 35-37% Phosphoric acid is used to etch dentine and enamel for 10-20 seconds and this step is followed by rinsing of the etched surfaces. It is recommended to leave the dentine slightly ‘moist’ (also called ‘wet bonding’).⁴²

**** Manufacturers of products used in this study are listed on page 105.**

The moist dentine is then infiltrated using a hydrophilic primer followed by application of the bonding resin (Adhesive) (Fig 2).⁴²⁻⁴⁴ The ‘bonding mechanism’ includes the formation of resin tags into exposed tubules (Intra-tubular bonding) and also resin infiltration into the exposed collagen network of demineralised dentine around the tubules (inter-tubular bonding) (Fig 3,4).^{44,45}

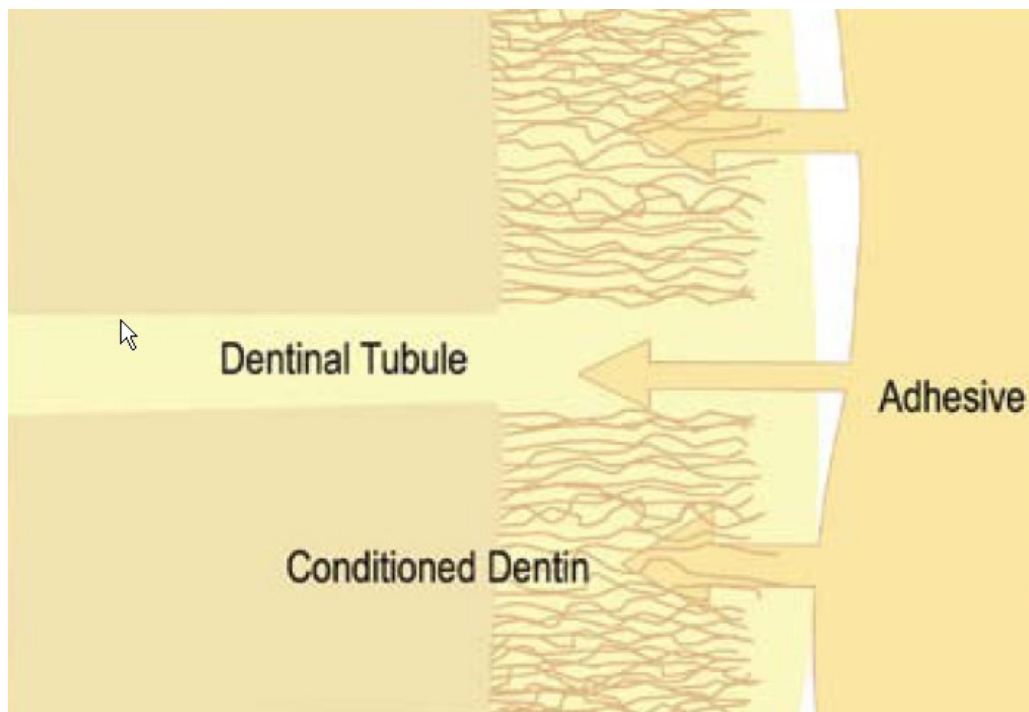

Fig. 2: Bonding agent penetration into etched dentine.

(With acknowledgement to Dr Mark E. Latta)⁴⁴

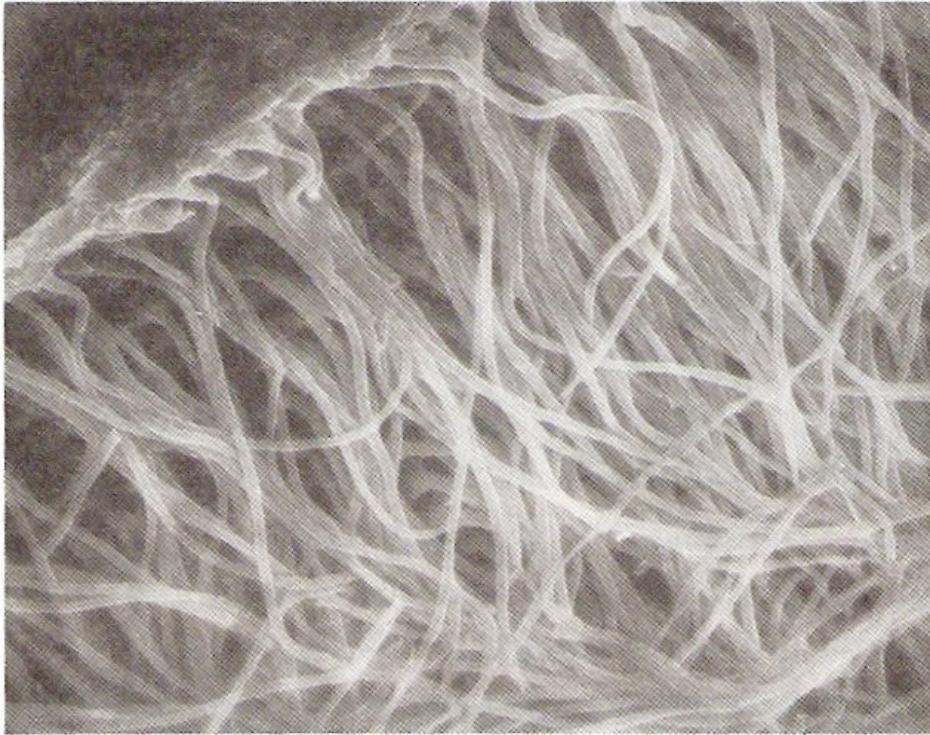

Fig. 3: SEM shows long resin tags projecting into the dental tubule
(With acknowledgement to Dr. John Gwinnett, State University of New York at Stony Brook)⁴⁵

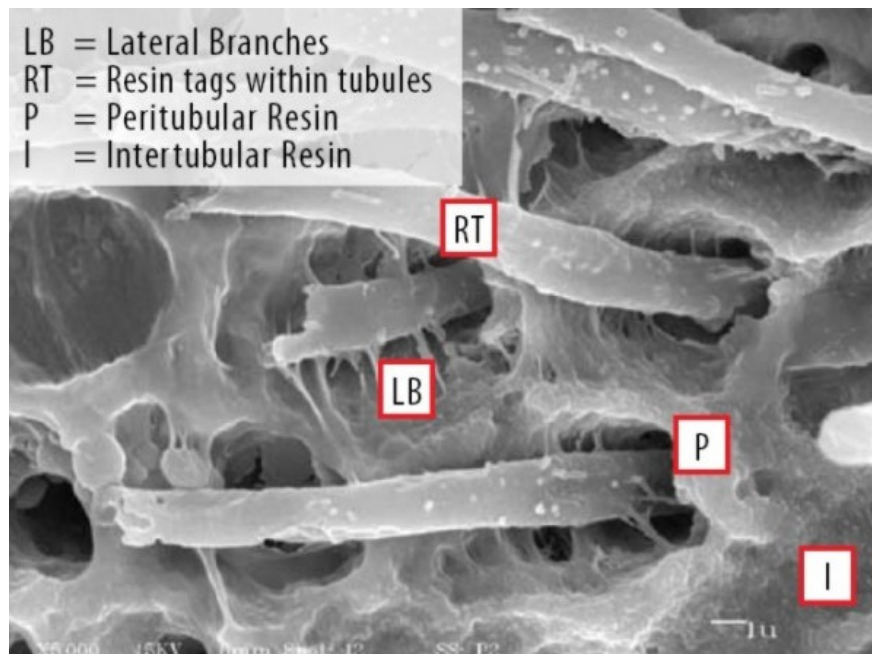

Fig. 4: Resin infiltration into tubules and demineralised dentine.
(With acknowledgement to Dr Walter Dias)⁴⁴

With the current fourth and fifth generation dentine bonding agents ‘hybridization’ involves a hybrid layer of 2-4 micrometers (Fig.5).⁴⁴ Following polymerization a hybrid layer is in place which serves a dual purpose – firstly to seal the cut tooth structure and tubules and secondly to provide a solid bonding foundation for the composite restoration.⁴⁵⁻⁴⁸

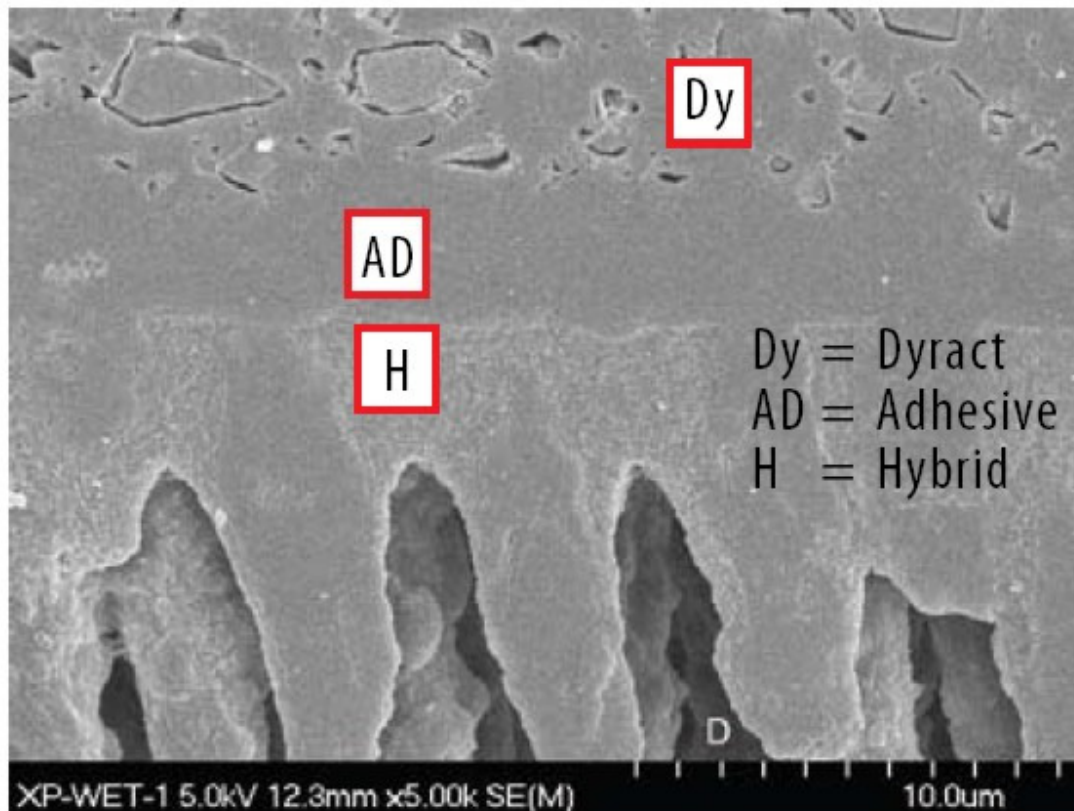

Fig. 5: SEM photograph showing the hybrid layer and adhesive layer.

(With acknowledgement to Dr. Jorge Perdigão)⁴⁶

Fifth Generation Dentine Bonding Agents

This generation is known as the single bottle, or ‘one bottle’, dentine bonding agents. They are sometimes also called the ‘two-step etch and rinse’ dentine bonding agents. In order to limit the number of application steps and thus decrease the working time, clinicians always request simplified clinical procedures for dental materials. This need

was addressed with the so-called ‘one bottle’ systems, where the ‘primer’ and the ‘adhesive resins’ are combined into one bottle. This not only reduces the number of steps in the bonding procedure, but it has also been shown that technique sensitivity is reduced. Although there is one less application step, the method of hybrid layer formation is similar to that of fourth generation products.^{49,50} Since the author did not include any fifth generation products as part of the research projects described in this dissertation, and focus is placed mainly on self-etching bonding agents, advantages and disadvantages applicable to fourth versus fifth generation dentine bonding agents will not be discussed.

Sixth Generation Dentine Bonding Agents

In order to further reduce the number of steps involved in the bonding procedure, ‘self-etching’ primers followed by application of a bonding agent (adhesive) were introduced as a simplified procedure.⁵¹⁻⁵⁴ These self-etching primers (with acidic monomers) are applied directly onto smear layer covered dentine, without the need for pre-etching with phosphoric acid.⁵⁵

A *sixth generation* dentine bonding agent is a two-bottle, self-etching dentine bonding agent, also called ‘two-step, self-etch’ bonding agents. Hybrid layer formation is similar to fourth generation products with the main difference that etching and subsequent demineralization is less aggressive.^{56,57} In general, the advantage is that less dentine is demineralised, and depending on the acidity, the smear plugs are often not completely removed.⁵⁷⁻⁶⁰ As a result it is easier to fully hybridize the demineralized dentine and more predictably seal tubules, often resulting in less post-operative sensitivity.^{61,62} Depending on the acidity of the self-etching primer the

smear layer is either modified or dissolved. The underlying dentine buffers/neutralizes the remaining acidity and the smear layer remnants are incorporated into the hybrid layer (Fig. 6).^{44,58,63-67}

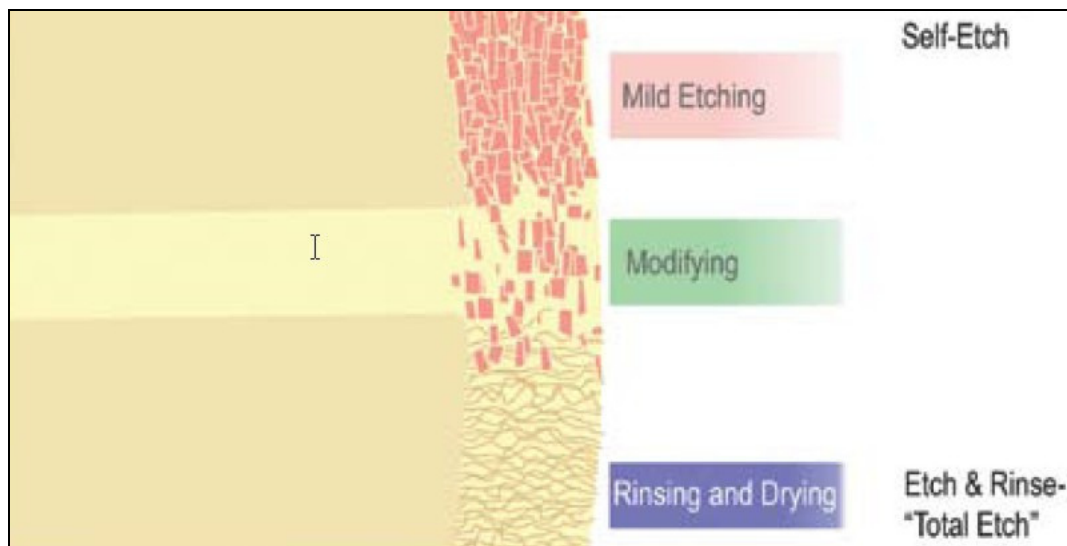

Fig. 6: Smear layer demineralization according to acidity.

(With acknowledgement to Dr Mark E. Latta)⁴⁴

Seventh Generation Dentine Bonding Agents

The seventh generation dentine bonding agents are one-bottle (one-step), self-etching dentine bonding agents. Except for the acid etching step, the method of application, action and hybrid layer formation is similar to the sixth generation products.^{68,69} The self-etching primer and adhesive resin are combined into one bottle.

Both the sixth and seventh generation self-etching bonding agents, with their simplified procedures (no separate acid etching step), are less technique sensitive to use and since the etching is generally less aggressive, (with less demineralization of

dentine), there is a reduced chance of incomplete resin infiltration. There might also be some additional chemical bonding with some of the self-etching bonding agents.⁷⁰⁻⁷² Chemical bonding could be to the advantage of both the clinician and patients, and warrants further investigation. The ‘evolution’ of bonding agents is presented in Figure 7. This figure is reproduced from a continuing education article prepared for INEEDCE by Nazarian in 2008 (Fig. 7).⁷³

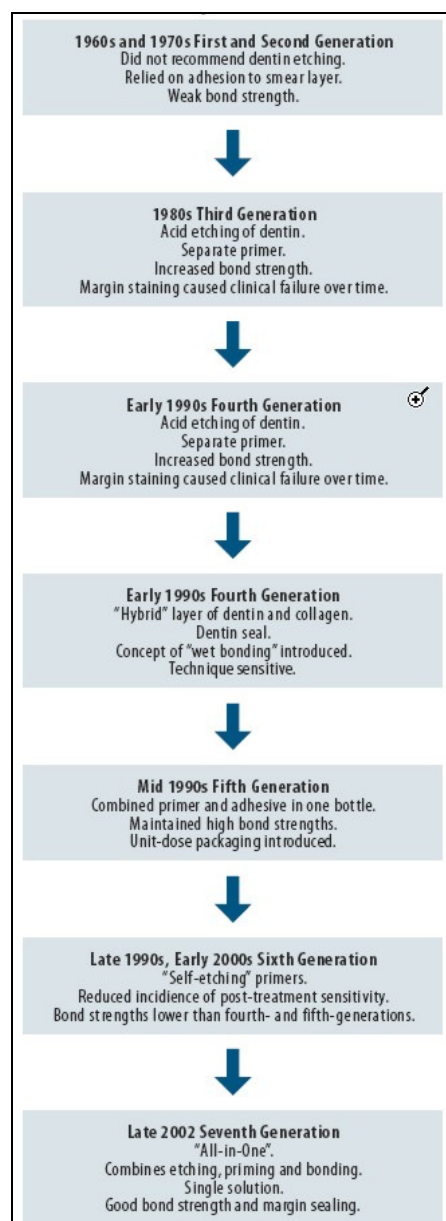

Fig. 7: Evolution of bonding agents.⁷³

2.4. Properties of an ‘Ideal’ Bonding Agent

The ‘ideal’ dentine bonding agent should not be technique sensitive to apply, should be able to permanently bond to wet as well as dry dentine and enamel, should not degrade in any form over time, should ideally be permanently anti-bacterial to withstand any form of secondary caries (bacterial) attack and should perfectly seal cut tooth structure, and should not allow micro-leakage under any form of mechanical, chemical or physical stress.⁴⁰ Nazarian (2008),⁷³ adds ‘thin film thickness’ and ‘fluoride releasing’ to the list of properties which an ideal bonding agent should possess.

Duke (2003),⁷⁴ states, that during the last 50 years, bonding agents have gone through a continuous evolution resulting in enhanced durability, and simpler application techniques. Today (in 2009) self-etching bonding agents have been through quite a few more years of ‘evolution’ and will hopefully now present the clinician with reliable, easy to use, clinically acceptable bonding/adhesive interfaces.

2.5. Testing of Dentine Bonding Agent Properties

- Despite all the modern improvements in bonding agents, composites and application techniques, post-operative sensitivity and microleakage due to polymerization shrinkage and shrinkage-related stress remains one of the biggest problems in modern clinical dentistry. Microleakage often leads to subsequent bacterial penetration and proliferation, which in turn could lead to secondary caries.^{75,76}

- The challenge remains to bond ‘perfectly’ and ‘permanently’ to tooth structure, but until such time that techniques and materials will offer this, researchers will have to look into ways of limiting or keeping bacteria out of microleakage gaps. An additional advantage would therefore be to use composites, liners and bonding agents with anti-bacterial properties, but these anti-bacterial properties will have to, ideally, remain active over many years.
- With self-etching bonding systems, a relatively new development in the field of restorative dental materials, one of the factors determining clinical success is the ability to bond the restoration to the exposed tooth structure effectively, thereby limiting microleakage.
- Evaluation and, as in the case of this study, comparison of bond strength, microleakage and possible anti-bacterial properties, are therefore as applicable to total-etch dentine bonding agents as they are to self-etching dentine bonding agents.

2.5.1. Testing of ‘Bond Strength’ to Tooth Structure

The ‘ideal’ dentine bonding agent should permanently bond a resin restorative material to both dentine and enamel with bond strength high enough to withstand polymerization shrinkage stress and other intra-oral factors such as variations in temperature and variations in mechanical loading. Ideally, the achieved ‘bond

strength' should therefore remain stable over the lifetime of the tooth, taking into account not only the above mentioned factors but also long-term chemical and hydrolytic attack endemic to the oral environment.

Research involving bond strength could measure bond strength values immediately after bonding (immediate bond strength) or at any given time after bonding, such as 24 hours after the bonding procedure. 'Immediately', upon leaving the dental practise, the patient will subject restorations and their bonds to a variety of mechanical and physical forces. Subsequently, during the months and years to follow, chemical and hydrolytic attack will also start playing an increasing role. Both 'immediate' and 'delayed' testing (maturing) of bonds therefore have relevance and research projects should clearly state these variables.

Shear bond strength evaluation is only one of many *in-vitro* screening tests that could be done to try and predict the ultimate clinical success of a bonding agent.^{77,78} This could be done on a single product,⁷⁹ comparing different products;⁷⁸ or comparing products against a control product (the 'control') which has proven itself in long-term clinical studies.⁸⁰ However, the validity of shear bond strength studies, as predictors of clinical success, and as comparison between products, is questioned because of many possible variables and the fact that standardization is so difficult to achieve.⁸¹⁻⁸⁴

According to Pashley *et. al.* (1995),⁸⁵ the quality of a bond may be evaluated either by tensile, shear, torsion, cleavage, pull, extrusion or 4-point bending tests. According to DeHoff *et. al.* (1995),⁸⁶ shear tests include the pull-shear test,⁸⁷ the push-shear test,⁸⁸ the planar interface shear test,⁸⁸ the conical-interface shear test,⁸⁹ and the lap shear

test.⁹⁰ Each of these tests have their own advantages but also limitations. In this dissertation we focussed on the planar interface test, which is the most-often-performed shear bond test in the literature, and for which we had the necessary instruments and testing facilities. The test method, the bonding jig and shear head used (Figs. 8-10) are described according to ISO TR 11405 which includes the methods and apparatus to be used for the testing of adhesion to tooth structure.⁹¹

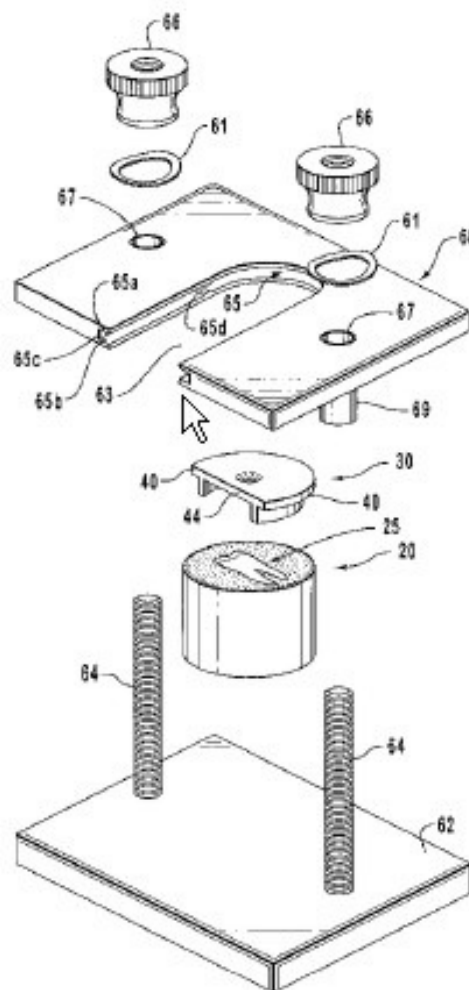

Fig. 8: Schematic drawing of the patented bonding jig used for ISO TR 11405.⁹¹

(numbers refer to components of the Jig – See reference 91)

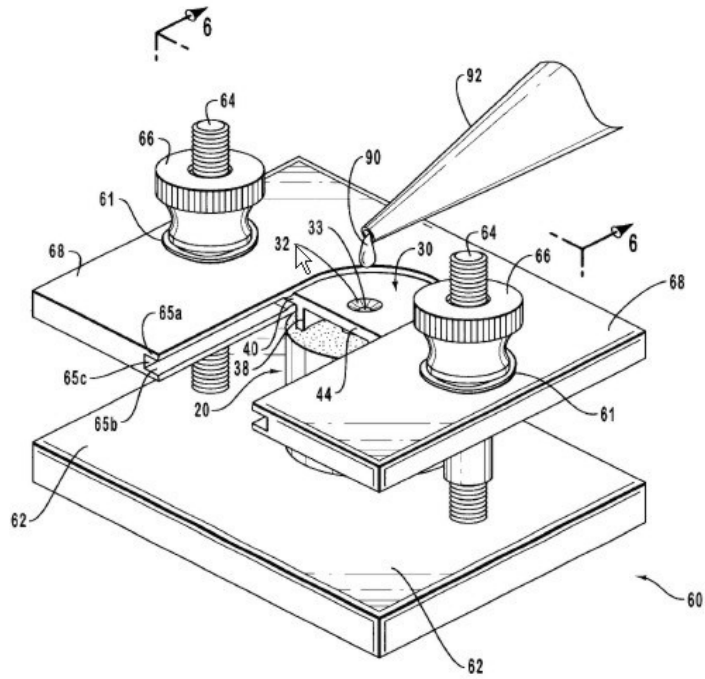

Fig. 9: Schematic drawing of the assembled bonding jig.⁹¹

(numbers refer to components of the Jig – See reference 91)

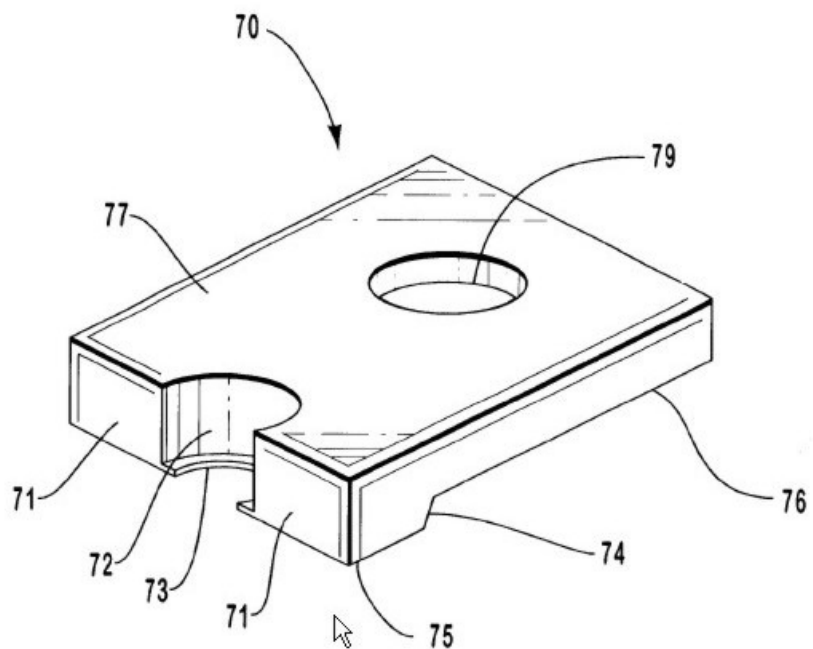
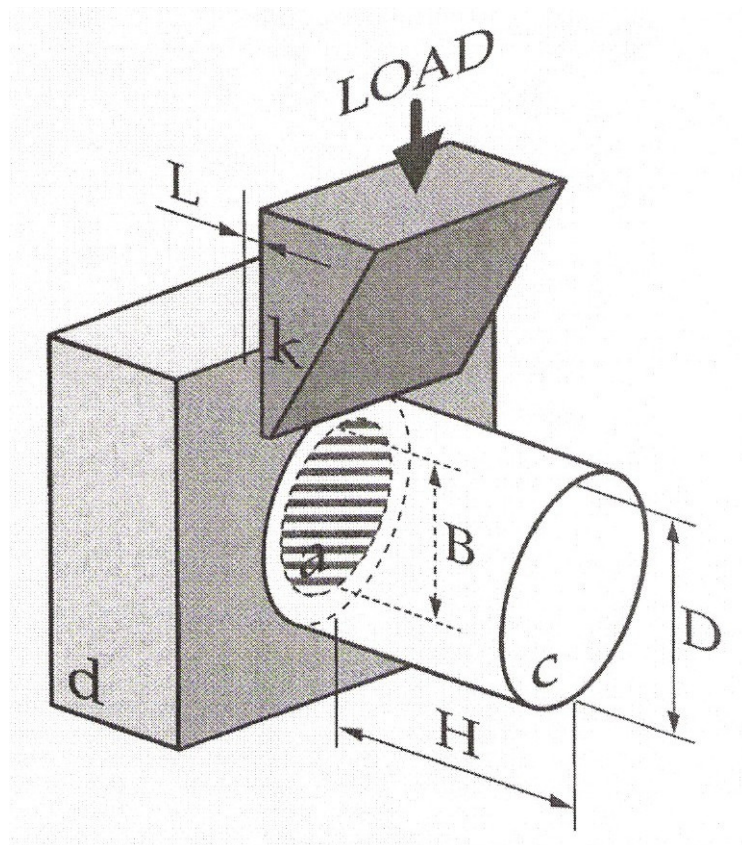

Fig 10: Patented, notched shear head.⁹¹

(numbers refer to parts of the shear head – See reference 91)

The basic principle of this test is that a tooth is prepared to expose a level surface of either enamel or dentine. A composite stub is bonded to the tooth using the bonding jig and relevant bonding agent. The stub is then sheared off the tooth with a blade or other shear load mounted in a loading machine, and operating at a pre-set, constant shear-head speed (Fig. 11).^{91,92}



c = composite, a = adhesive, d = dentine, k = blunt knife edge

Fig. 11: Schematic drawing of a shear test using a blunt knife-etch shear head.⁹²

A review of the literature points to the fact that there is very little standardization of shear bond tests and that there are many possible variables that could influence the outcome (values) and therefore the results.⁹³⁻⁹⁶ A specific 'high' or 'low' value on its own does not have much value as it depends on many variable factors. The values obtained in any specific experimental set-up only has value if all the samples are

tested with the same experimental set-up and under the same laboratory conditions, as part of the same experiment.⁹⁵ In other words, one cannot do part of the test today, some more the next day etc. All possible attempts should be made to standardize everything for all the samples being tested in the specific experiment.⁹³ Values then obtained can only be used to grade the samples of the specific test from high to low and then draw statistical conclusions from that. Again it has to be emphasized that bond strengths is only one of many possible *in-vitro* tests which could be performed, and also that the highest, 'best' values does not necessarily mean that a specific bonding agent will perform the best in a clinical situation.

Figure 12 is an example of published shear bond strength data for a selection of self-etching bonding agents.⁷³ Although it indicated that the product Optibond All-in-One showed the highest bond strength to both enamel and dentine, it does not necessarily mean that this product will perform best in the clinical situation. Other important evaluations of product properties such as resistance to hydrolysis or resistance against occlusal loading might be poor for this product, which might make it less successful in the clinical situation. The results of any bond strength study are only valid if used as a grading between the specific products which were tested. It might not be proof of good bonding in the clinical situation and there might be many products on the market which might perform better, if only they had been included in the same study.

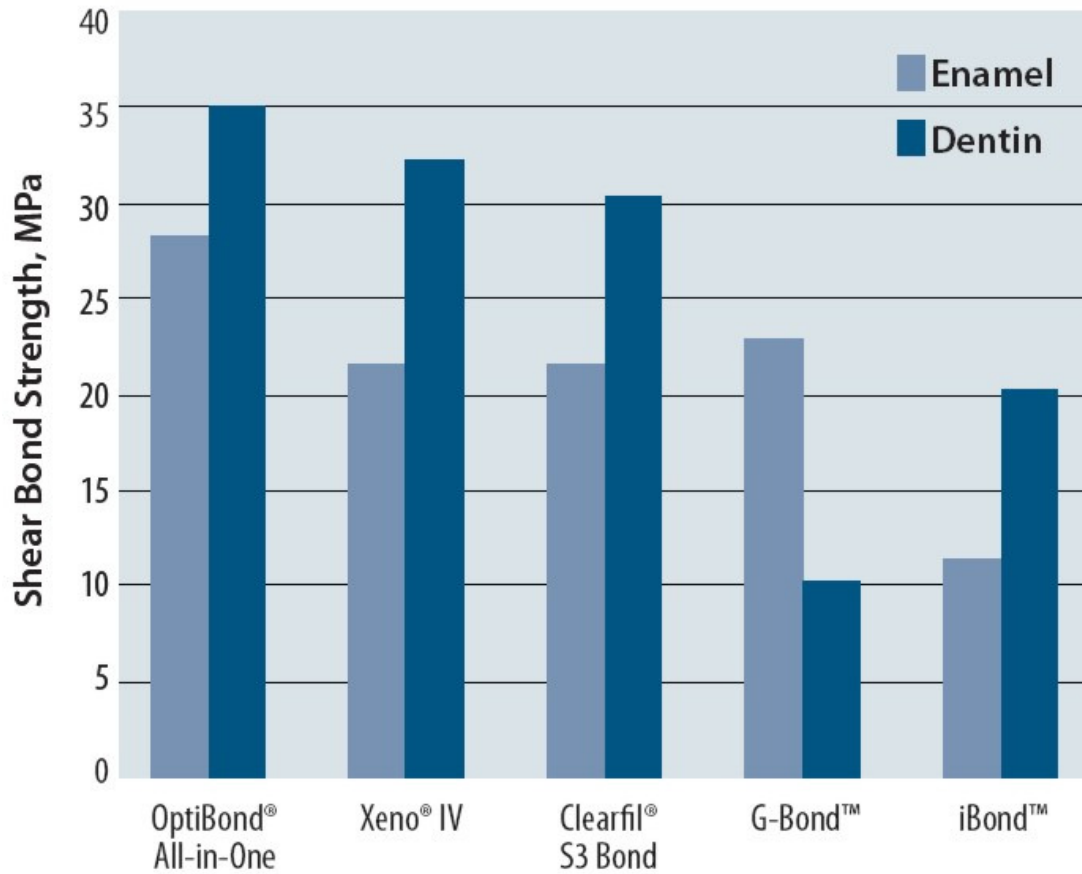

Fig. 12: Example of shear bond research results ⁷³

Al-Salehi and Burke (1997),⁸¹ evaluated 50 studies on dentine bond strength and drafted two tables listing all the variables which had been included in the various studies (Table I & II). Judging from the number of variables listed it is clear that a comparison of products is virtually impossible. They further analysed the results of these studies which revealed some interesting facts (Table III).⁸¹ LeLoup *et. al.* (2001),⁹⁵ also lists variables in his meta-analysis of factors involved in dentin bonding.



Variable	No. (%)
<i>Type of dentin</i>	
Human	44 (88%)
Bovine	5 (10%)
Both	1 (2%)
<i>Tooth notation</i>	
Molar	35 (70%)
Premolar	1 (2%)
Incisor	2 (4%)
Bovine	5 (10%)
Not stated	7 (14%)
<i>Dentinal surface preparation</i>	
Silicon carbide	39 (78%)
Diamond bur	6 (12%)
Aluminum oxide	1 (2%)
Not stated	4 (8%)
<i>Dentinal depth</i>	
Superficial	5 (10%)
Midcoronal	4 (8%)
0.5 mm dentin removed	2 (4%)
Various depths	2 (4%)
Outer third of dentin exposed	1 (2%)
Not stated	36 (72%)
<i>Moist vs dry dentin</i>	
Dry	4 (8%)
Wet	1 (2%)
Dry and wet	10 (20%)
Not stated	35 (70%)
<i>Film thickness</i>	
Very thin	2 (4%)
Air thinning	3 (6%)
20 μ L used	1 (2%)
Not stated	44 (88%)
<i>Thermal cycling</i>	
500 cycles	4 (8%)
Various other cycles	5 (10%)
Not stated	41 (82%)
<i>Storage medium</i>	
Water/saline	43 (86%)
Chloramine	1 (2%)
Incubator @ 37°C/100% humidity	1 (2%)
Various	1 (2%)
Not stated	4 (8%)

Table I: Specimen preparation variables in 50 studies of dentine bond strength.⁸¹



Variable	No. (%)
<i>Time of testing</i>	
24 h	34 (68%)
48 h	3 (6%)
7 d	2 (4%)
1 min, 24 h	2 (4%)
15 min, 24 h, 4 wk	1 (2%)
24 h, 1 wk	1 (2%)
10 min	1 (2%)
24 h, 6 mo, 1 y	1 (2%)
1 min, 15 min, 24 h, 1 wk, 4 wk	1 (2%)
3 h, 6 h, 10 h, 12 h, 24 h	1 (2%)
30-45 min	1 (2%)
Not stated	2 (4%)
<i>Machine used</i>	
Instron	48 (96%)
Not stated	2 (4%)
<i>Method of loading</i>	
Shear	40 (80%)
Tensile	9 (18%)
Shear and tensile	1 (2%)
<i>Loading rate</i>	
5.0 mm/min	21 (42%)
1.0 mm/min	6 (12%)
0.5 mm/min	15 (30%)
Other	6 (12%)
Not stated	2 (4%)
<i>Mode of failure</i>	
Adhesive	1 (2%)
Cohesive	7 (14%)
Adhesive and cohesive	13 (26%)
Not stated	29 (58%)

Table II: Testing variables in 50 studies of dentine bond strength.⁸¹

Analysis of the 50 investigations revealed the following facts:

1. Shear tests predominated, being used in 80% of the papers (n = 40).
2. Dentin from human molar teeth was used in 88% of tests (n = 44).
3. Water or saline solution was used as the storage medium in 86% of the investigations (n = 43).
4. The most prevalent time of testing was at 24 hours (68% of investigations; n = 34).
5. The surface area of contact, or the diameter of the specimens, was stated in 94% of investigations (n = 47). The mean diameter of these 47 specimens was 3.97 mm.
6. The most prevalent loading rate was 5.0 mm/min. This rate was used in 42% of the investigations.
7. Silicon carbide was the most common form of surface preparation, being used in 78% of studies.
8. An Instron testing machine was used in 96% of the studies assessed.

A number of potential variables were predominantly not recorded, namely, film thickness, type and depth of dentin tested (ie, superficial or deep), moist or dry dentinal surface, and, whether or not thermal cycling was carried out (Tables 1 and 2).

Table III : Analysis of the 50 studies. ⁸¹

From the above it is clear that shear bond strength testing is done in many different experimental set-ups and that it will be very difficult to compare results from different studies with each other. The only possible value one could gain would be a grading of different products in the same experimental set-up and then to compare results from different 'similar' shear bond experiment to look for 'trends' which might indicate a constant/persistent higher or lower bond strengths between a selection of products.

In this dissertation the author performed a dentine shear bond strength study during which a selection of self-etching products was compared to a total-etch dentine bonding agent, which was used as a control. The value of this sort of study is that the new generations of self-etching products are evaluated against a clinically proven product. Should bond strength values of the self-etch product statistically compare to the ‘proven’ product, then it might be predicted that, at least as far as bonding to dentine is concerned, the self-etching product may perform clinically as well as the clinically proven product.

Over the last 10 years Scotchbond Multipurpose Plus^a has proven its ability to bond successfully to dentine, and as previously mentioned, this product can be seen as a ‘golden standard’ against which other products can be evaluated.^{33-35,37,94} During the shear bond strength study the author compared the dentine shear bond strength of this proven product with a selection of self-etching dentine bonding agents. It was hypothesised that these self-etching products, as far as shear bond strength to dentine is concerned, would perform statistically comparable to Scotchbond Multipurpose Plus^a. The outcome could then be that the author might recommend to clinicians, that as far as dentine shear bond strength, the self-etching bonding agents used in this study could be considered as suitable alternatives to Scotchbond Multipurpose Plus^a and most probably also to other fourth generation dentine bonding agents.

2.5.2 Testing of Microleakage

Various researchers have worked on microleakage associated with dentine bonding agents and composite resins.⁹⁶⁻⁹⁹ As mentioned previously the ‘ideal’ dentine bonding

agent should ‘perfectly’ seal and permanently bond a restoration to cut tooth surfaces. Microleakage allows bacteria to penetrate into the space between the restoration and cut tooth surfaces. Bacteria can pass through gaps in the order of 0.3-1.5 μ m. These micro-gaps also allow penetration of moisture, nutrients and oxygen. This, coupled with body temperature, provides the ideal ‘habitat’ for bacteria to thrive in. The consequences of this situation are well known namely, bacterial proliferation, acid production, demineralization, and finally the formation of secondary caries (Fig.13).⁴⁴

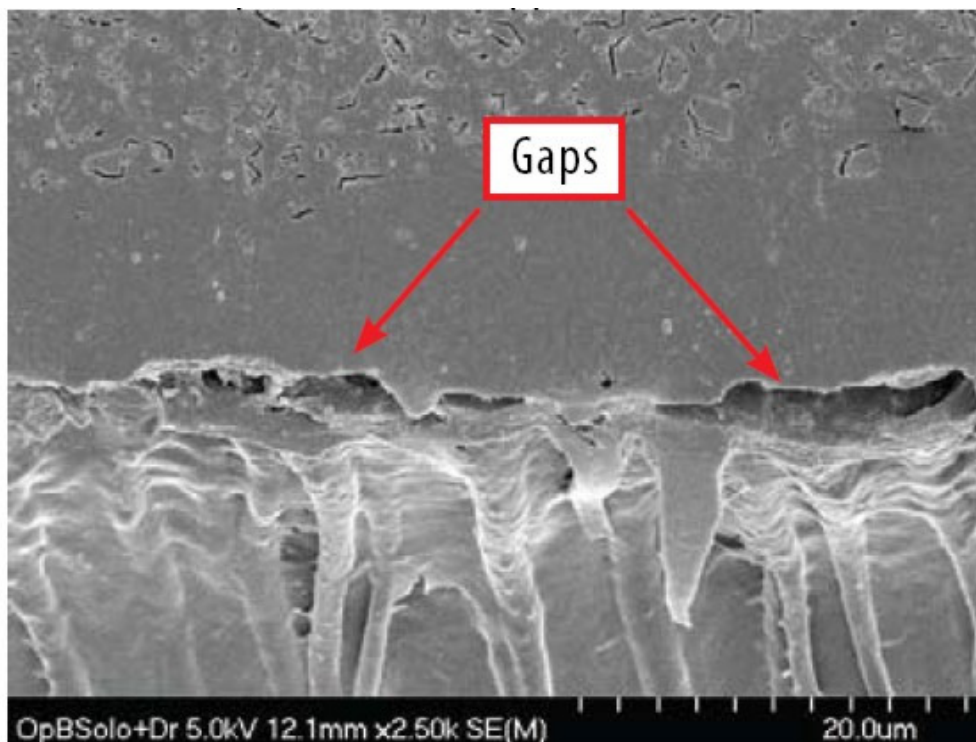

Image courtesy of Dr. Jorge Perdigão

Fig. 13: SEM photograph of the adhesive interface with shrinkage related gaps.⁴⁴

These gaps (and subsequent microleakage) are often caused by polymerization stress. Gaps can also form at a later stage if the bond is not able to withstand the mechanical stresses from mastication or para-functional jaw movements. Shrinkage or expansion of the restoration due to heat or cold could also cause the formation of gaps due to the

difference in the coefficient of thermal expansion (COTE) between the restorative material and tooth structure. For this reason thermocycling (thermal cycling) is a useful procedure which is used to stress bonds in order to simulate intra-oral conditions.⁹⁹ Once the micro-gap has formed, and/or the bond has been broken, a potential avenue for bacterial penetration exists.

From the above it should be clear that it is important for any bonding agent, not only to bond to the tooth and restoration with a 'bond strength' sufficient to withstand shrinkage related stress, but also to permanently and completely seal the tooth structure. Since shrinkage and shrinkage stress remains a reality, there is a need to investigate whether certain bonding agents bond and seal better than others, allowing less microleakage to take place.

As is the case with *in-vitro* shear bond strength evaluations, *in-vitro* microleakage evaluations do not necessarily predict clinical success or failure, but it can be used to compare different products and product types. The purpose of the current study was to determine whether microleakage values of the self-etching dentine bonding agents compare favourably with the microleakage values of the control product, Scotchbond Multipurpose Plus.^a

The literature indicates considerable variability in testing parameters and procedures used by authors.¹⁰⁰⁻¹²⁶ As can be seen from the listed studies, thermocycling regimes, dye penetration testing regimes and cavity preparation techniques vary considerably. The technique chosen (for this dissertation) to evaluate microleakage has often been used by researchers and is not unique, although some of our variables might be

different to some other evaluations described in the literature. The same experimental set-up was used for all the products evaluated in this part of the study - all variables were kept constant for all the products evaluated. Other experimental set-ups might produce a different numerical set of data, but the ranking of products should be similar.

Expanding on the value and importance of microleakage research: It is well known that microleakage which occurs at the interface between the restorative material and the tooth can lead to post-operative sensitivity, chronic hypersensitivity, recurrent caries and pulpal complications.^{127,128}

There are many possible techniques which could be used to study microleakage and there are many variables applicable. As with shear bond strength testing, microleakage could be evaluated immediately after bonding or after a certain time delay. The bond, as well as the restoration, could also be subjected to certain stresses before microleakage is evaluated. Examples of such stresses are temperature variations (simulated through thermocycling)¹⁰⁰⁻¹⁰⁹ and mechanical occlusal loading¹⁰⁷ using a variety of ‘chewing’ simulators (cyclic mechanical or flexural loading).

Microleakage can be determined using a variety of techniques. Some are listed below:

- Evaluating marginal integrity, gaps and measuring ‘gap’ formation.^{100,101,110-113}
- Dye penetration (various dyes and regimes).¹¹⁴⁻¹²²
- Electrical impedance measurements.¹²³⁻¹²⁵
- Radio-isotope penetration.¹²⁶

The complexity and importance of microleakage testing can be demonstrated by looking at the contents of a course on microleakage presented by the Ankara University in Turkey (Fig. 14).

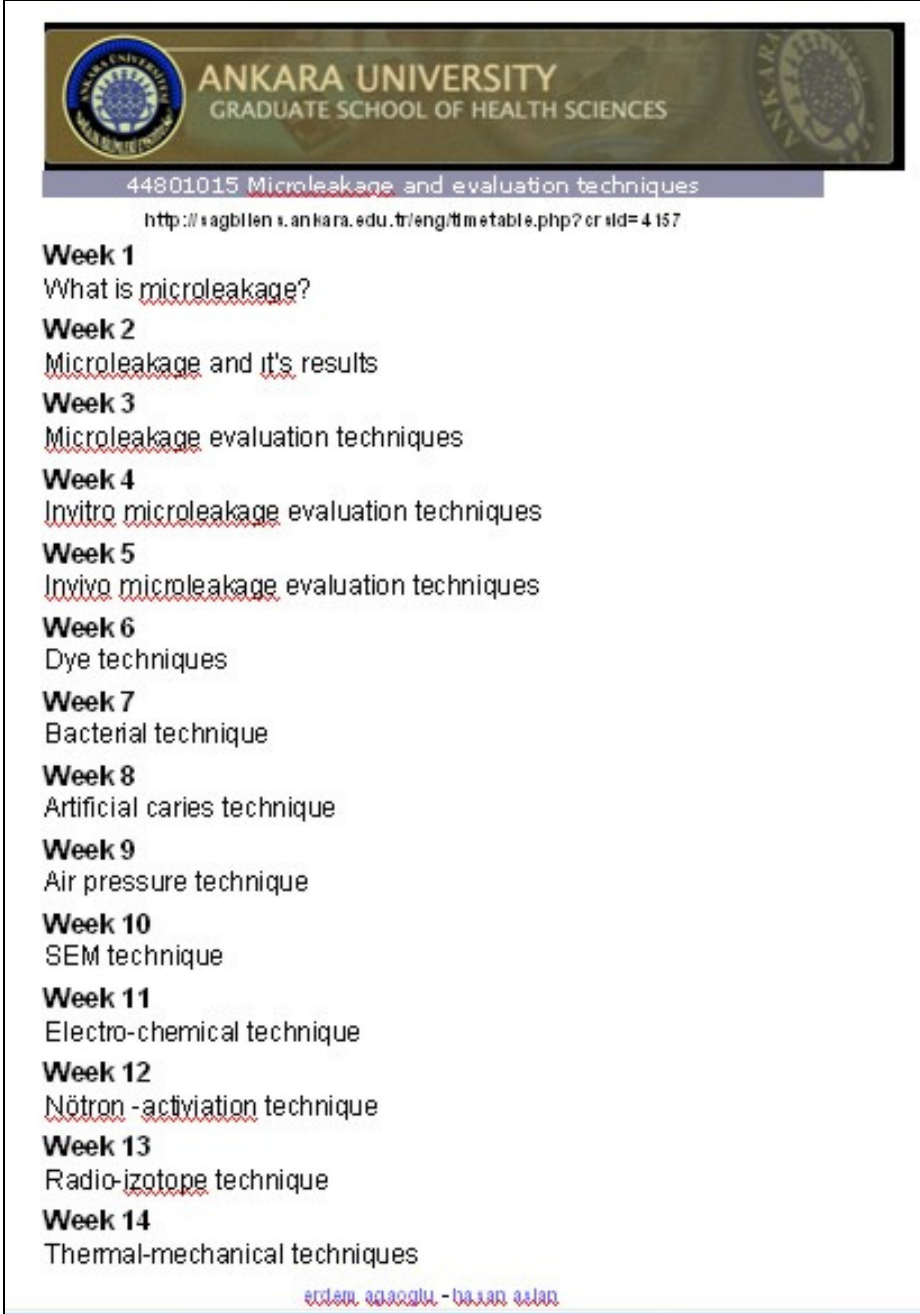

ANKARA UNIVERSITY
GRADUATE SCHOOL OF HEALTH SCIENCES

44801015 Microleakage and evaluation techniques
<http://sagbilgen.s.ankara.edu.tr/eng/timetable.php?crsid=44801015>

Week 1
What is microleakage?

Week 2
Microleakage and it's results

Week 3
Microleakage evaluation techniques

Week 4
Invitro microleakage evaluation techniques

Week 5
Invivo microleakage evaluation techniques

Week 6
Dye techniques

Week 7
Bacterial technique

Week 8
Artificial caries technique

Week 9
Air pressure technique

Week 10
SEM technique

Week 11
Electro-chemical technique

Week 12
Nötron -activation technique

Week 13
Radio-izotope technique

Week 14
Thermal-mechanical techniques

erdem adanali - bayan esler

Fig. 14: Example of a microleakage course presented by the Ankara University

Most research projects use a single or multiple coats of nail varnish to cover the tooth around the restoration which is then subjected to dye penetration studies.^{115,117-122,129-133} None of the authors cited discuss their reasons for using this procedure, neither do they provide references to justify this procedure. The tooth is covered with varnish, leaving one or two millimetres of tooth structure clear around the restoration. Other than keeping the tooth 'clean' from dye, a secondary perceived advantage is perhaps that varnish may prevent leaking of dye towards the tooth-restoration junction via cracks in the tooth. The author could, however, not find the original research advocating this procedure, nor does it seem to be a pre-requisite for a favourable outcome. If there are any cracks in the tooth it will still be exposed in the 'clear' uncovered 1-2 mm surrounding area, thus allowing penetration of dye towards the restoration. In this research project the author did not cover the teeth with nail varnish. The teeth were carefully inspected for any cracks and unwanted dye penetration pathways. It did take some time and effort to subsequently remove excess surface dye but no unwanted dye penetration/contamination was found.

Should this indeed be a problem, a more logical measure could be to inspect all teeth using a microscope for cracks around the prepared/prepared cavity before it is placed in the dye. When deciding to cover the tooth with varnish care should be taken not to contaminate the cavity area with varnish. It is very difficult to keep a one millimeter border clear of varnish, and should this be attempted, it is advisable to do this with magnification and a special brush. 'Contamination' of the restoration-tooth interface with varnish can easily take place as was found by the author during some pre-testing.

Scotchbond Multipurpose Plus^a was also used as control and ‘golden standard’ for the microleakage part of the study.^{33-35,37,94} During this part of the study the author compared dentine and enamel microleakage of Scotchbond Multipurpose Plus^a with dentine and enamel microleakage of a selection of self-etching bonding agents. It was hypothesised that these self-etching products, as far as dentine and enamel microleakage values are concerned, would perform statistically comparable with Scotchbond Multipurpose Plus^a.

2.5.3. Testing of Anti-Bacterial Properties

Over the years many research projects have been performed on possible anti-bacterial properties of various dental materials. Tobias *et. al.* (1988),¹³⁴ evaluated the anti-bacterial activity of a calcium hydroxide base, a conventional amalgam, a high copper amalgam, a composite resin and a polycarboxylate cement, using an agar well technique. Six micro-organisms found in ferret plaque were used in that study and the outcome was that most materials showed some anti-bacterial activity when freshly mixed, but the effect varied for different micro-organisms. A marked reduction was found in the anti-bacterial activity of all materials after setting for 1 and 7 days.¹³⁴ Yap *et. al.* (1999),¹³⁵ investigated fluoride release and anti-bacterial properties of fluoride-releasing composites, compomers and a resin-modified glassionomer. The authors also used an agar well technique and evaluated activity against three types of micro-organisms (*Lactobasillis casei*, *Streptococcus mutans* and *Streptococcus sobrinus*). They concluded that none of the materials affected the growth of the three bacteria included in that study.¹³⁵ Two studies done on the anti-bacterial properties of amalgam provided proof that amalgam display anti-bacterial properties.^{136,137} One of

these studies compared amalgam to composite, showing that composite lacks the anti-bacterial properties of amalgam.¹³⁶ A number of research projects were done on the possible anti-bacterial properties of glassionomers and resin-modified glassionomers. Results varied, but most products evaluated did show some activity against bacteria. However, most of these research projects only evaluated short term (or immediate) anti-bacterial activity and data on the possible long-term anti-bacterial efficacy is not available.¹³⁸⁻¹⁴³

Growth Media and Bacteria (Test Organisms)

Tobias (1988),¹⁴⁴ did a review of the literature since 1890 and found that the agar diffusion inhibitory test was used most often to assess the anti-bacterial activity of dental materials. His review concluded that there is a need for international standards for the biological testing of dental materials, in particular the strains of test micro-organisms and growth media to be used.¹⁴⁴ Agar cultures were used in most of the anti-bacterial studies described in the literature. In this study the author also used a standard Agar well diffusion technique. The literature describes some variations and alternatives to the above techniques, each with its own advantages and limitations.¹⁴⁵⁻

148

Bacteria used in anti-bacterial studies also vary, probably because researchers realize that a wide variety of bacteria are found in the mouth, on teeth and in cavities. Since this current study was investigating the effect of possible anti-bacterial properties of dental materials on bacteria found in carious teeth, the following three bacteria were chosen as representative organisms - *Streptococcus mutans*, *Lactobacillus paracasei*

and *Actinomyces naeslundii*. These three organisms play an important role in the caries process and in caries progression and are often used in studies.¹⁴⁹⁻¹⁵⁶

Chlorhexidine

Chlorhexidine is a potent anti-microbial agent with proven efficacy against a variety of oral bacteria. A Pubmed search (June 2009) with keywords ‘Chlorhexidine’ and ‘Bacteria’ resulted in a list of more than 2000 references. A few research projects investigated the addition of Chlorhexidine as an ingredient of dental materials or as cavity disinfectant before restorations are placed.^{157,158} Others added it to their research projects as a control against which the efficacy of potential anti-bacterial substances could be evaluated.¹⁵⁹⁻¹⁶⁶ The author also used Chlorhexidine as control in the current project.

MDPB (12-methacryloyloxydodecylpyridinium bromide)

Recently, during 2006, the Kuraray company launched a self-etching bonding agent called Clearfil Protect Bond^b. This product has an anti-bacterial substance added to the proprietary resin MDP and is called MDPB (12-methacryloyloxydodecylpyridinium bromide).¹⁶⁷⁻¹⁷⁰ The experimental name of Clearfil Protect Bond at the time of this study was ABF^b. This study investigated the immediate anti-bacterial properties of ABF^b which might assist in ‘disinfecting’ the cavity better before restoration placement. Testing of the long-term/sustained anti-bacterial properties did not form part of this investigation. The primary objective of this study was to determine the anti-bacterial efficacy of the primer of ABF^b and to compared it to the primer of a standard self-etching dentine bonding agent Clearfil SE

Bond^c, and to the primer of a fourth generation dentine bonding agent, Scotchbond Multipurpose Plus^a.

It was hypothesised that, due to chemical compounds and solvents such as the ethanol and acetone which are present in most dentine bonding agents, they would show some form of anti-bacterial properties. ABF^b was expected to have the best anti-bacterial properties - as claimed by the manufacturer. If any of the products evaluated in this study proved to display superior anti-bacterial properties, it would be a definite advantage to the clinician to use such a product.

3. Materials & Methods

Note: The names and addresses of the manufacturers of all the materials and equipment used in this study are mentioned in Section 10 (Page 105) of this dissertation.

3.1. *In-vitro* Shear Bond Strength Evaluation

The following products were evaluated: Scotchbond Multipurpose Plus^a (SBMP) (control) and five self-etching bonding agents i.e. ABF^b, Clearfil SE Bond^c, Xeno III^d, Optibond Solo Self-etch^e, and Adper Prompt-L-Pop^f.

Sixty recently extracted, human, third molar teeth were used. After extraction these teeth were cleaned and stored, for a maximum of two weeks before use, in a 0.1% Thymol^g solution at 4 degrees centigrade. They were subsequently mounted in stainless steel rings in acrylic resin with their occlusal surfaces exposed. Using an Impitech^h polishing machine the occlusal surfaces were subsequently ground flat to expose superficial dentine (Fig. 15). A standardized smear layer was created by polishing with wet 600-grit Silicone Carbide paper.⁹⁶

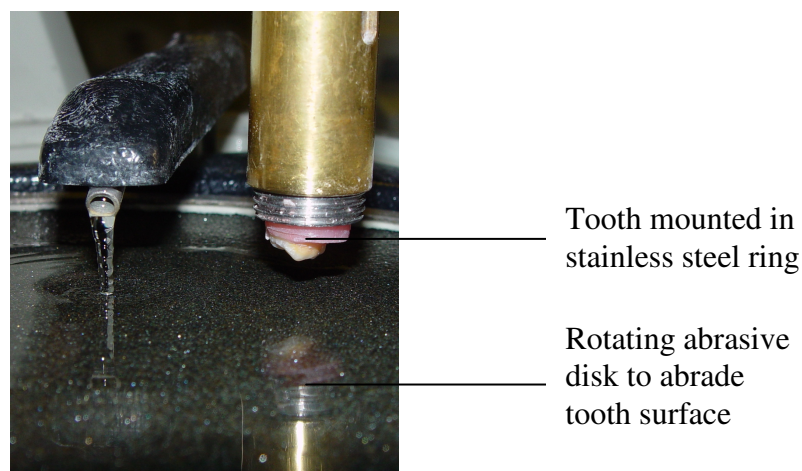

Fig. 15: Grounding technique to produce flat/level dentine surfaces.

The sixty imbedded teeth were randomly divided into six groups of ten teeth each to accommodate the five bonding agents and the control. The bonding agents were applied and cured strictly according to manufacturer's instructions.

Using two increments of Z100ⁱ, A1 shade composite, a resin stub (diameter 2.3798 mm, length 3.0mm) (Fig. 16) was constructed on each of the prepared dentine surfaces using an Ultradent jig^j (Fig. 17).

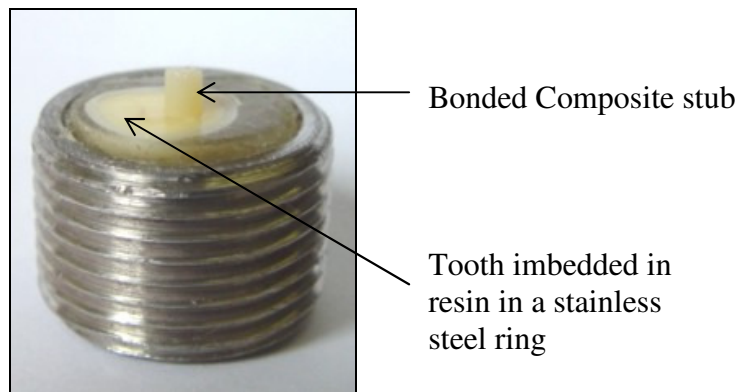

Fig. 16: Mounted tooth with composite stub



Fig. 17: Ultradent bonding jig^j (as per ISO TR11405⁹¹ – see also Fig. 9)

After placement of the first increment, the composite was cured for 20 seconds with an Optolux 501^k curing light, the second layer was then applied and again cured for 20 seconds. The teeth were removed from the bonding jig and each stub further cured for 20 seconds from opposing directions.

The mounted teeth were then placed into a special ring clamp^l manufactured by Ultradent (Fig.18). Using an Ultradent shear-head attachment^m (Fig. 10, 19) the stubs were stressed to failure with an Instronⁿ universal testing machine, operating at a crosshead speed of 0.5 mm/min. The data was statistically analysed using the ANOVA test ($\alpha \leq 0.05$).

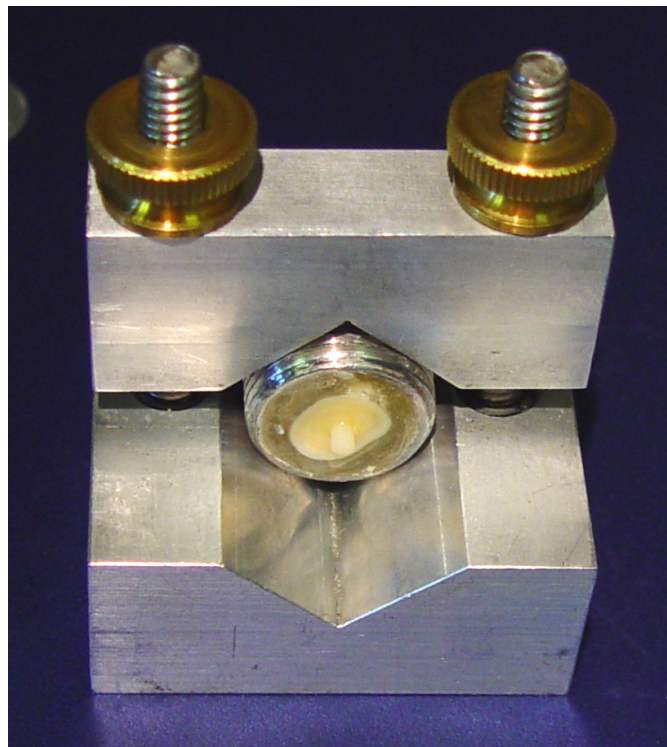

Fig. 18: Ultradent ring clamp^l for Instron test

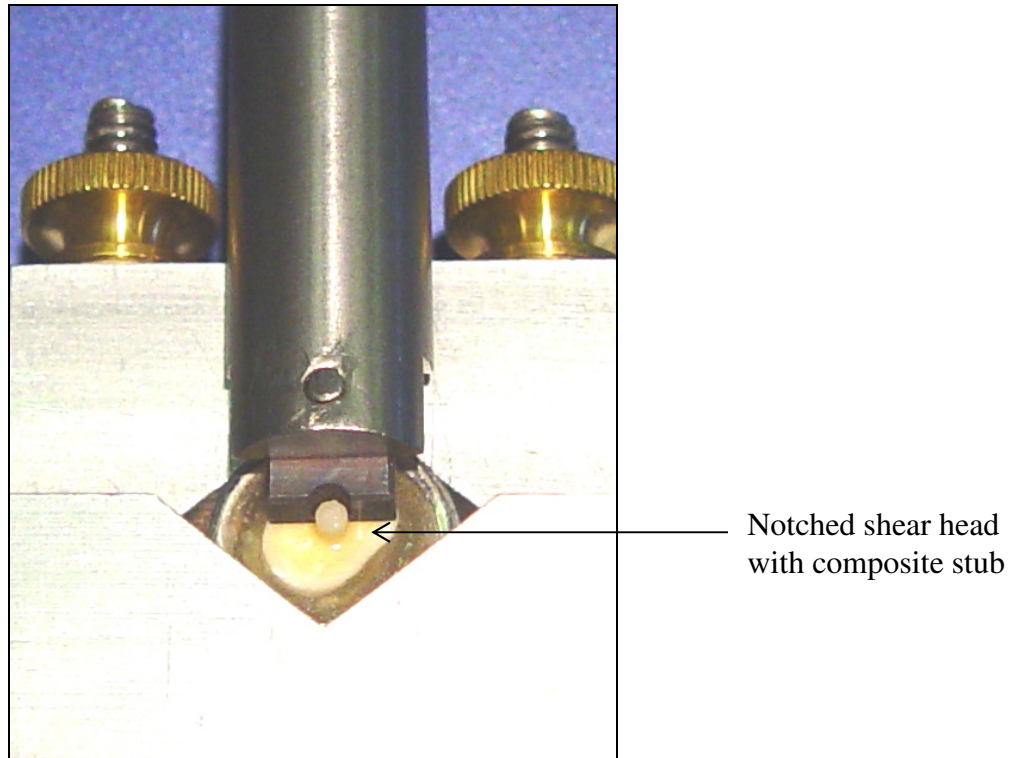

Fig. 19: Shear-head attachment^m for the Instron testing machineⁿ

(See also **Fig. 10**)

3.2. *In-vitro* Microleakage Evaluation

Seventy freshly extracted, intact, caries free human third molars were scaled, cleaned with a slurry of pumice and stored in a sodium azide solution at 5°C. In each tooth a standard, cylindrical preparation was made at the cemento-enamel junction (CEJ) using a size medium Cerana^o bur (Figures 20 & 21). The teeth were subsequently randomly divided into 7 groups of ten teeth each.

Bonding agents were applied and light cured strictly according to the manufacturer's instructions. Bonding agents used in this study were Optibond Solo Plus Self-Etch^p,

ABF (Clearfil Protect Bond)^b, Clearfil SE Bond^c, Xeno III^d, OneCoatSE Bond^q, iBond^r and Scotchbond Multipurpose Plus^a as a control.

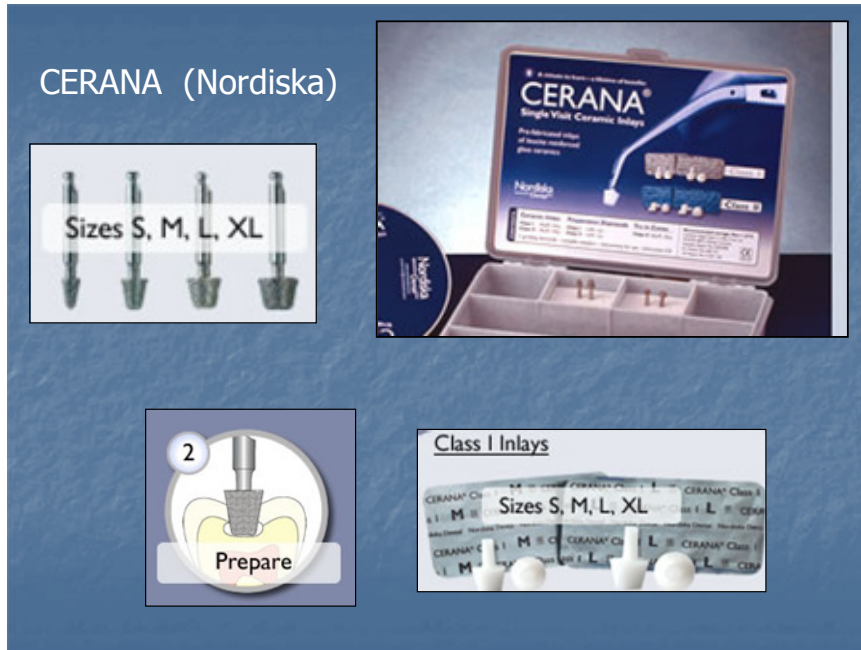

Fig. 20: Cerana Bur kit from the Cerana Inlay System^o (Nordiska Dental)

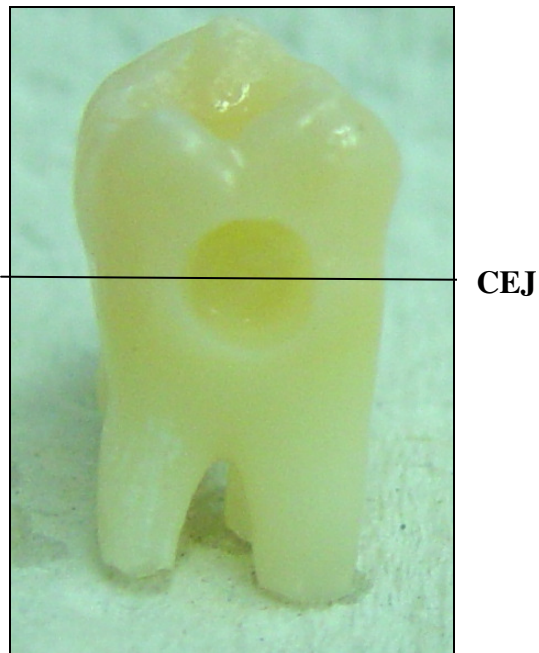
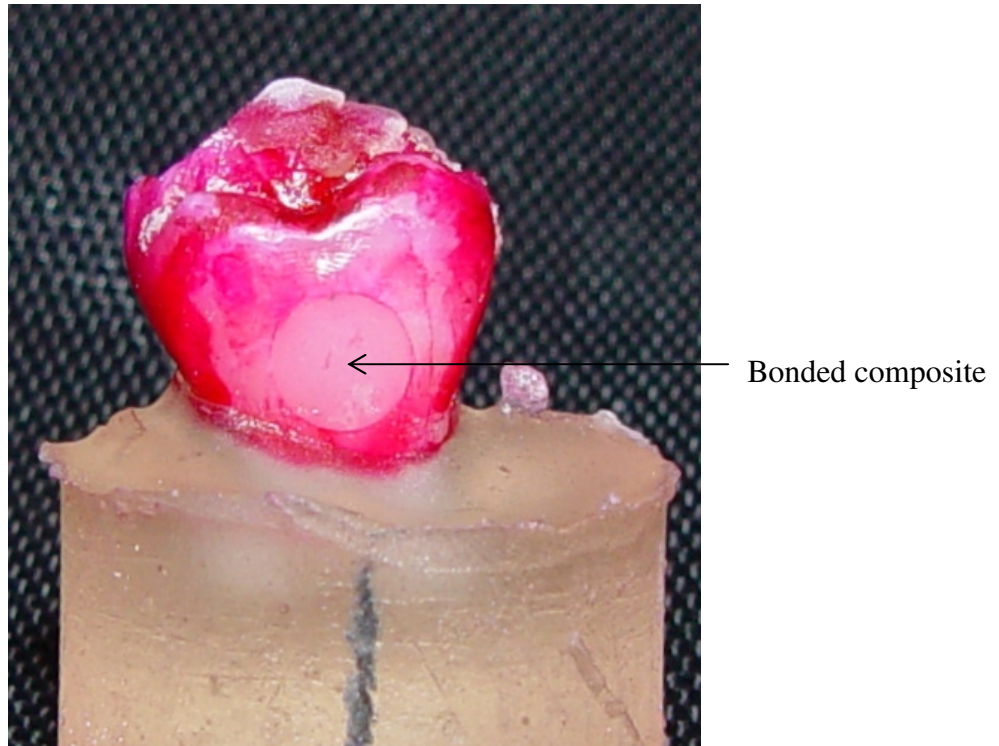

Fig. 21: Prepared cavity at the cemento-enamel junction (CEJ)

The cavities were restored using two incremental layers of Z100ⁱ (A1) composite. Each layer was cured for 20 seconds using an Optolux 501^k curing light. The cavities were slightly overfilled when placing the last layer. The restored teeth were then stored overnight for 12 hours in distilled water at 37°C. The restorations were subsequently finished and polished using Sof-Lex discs^s and Enhance Polishing cups^t and then imbedded in acrylic resin.

The teeth were then thermocycled between 5 and 60° C ($\pm 2^\circ$ C) for 250 cycles with a 20 second dwell time.¹⁷¹

All seven groups were then placed in a 0.5% basic Fuchsin^u solution for 12 hours at 37° C. The teeth were then removed from the basic Fuchsin^u and rinsed well (Fig. 22), imbedded further in acrylic resin (Fig. 23) and cut longitudinally through the centre of each restoration using an Accutom-2^v cutting machine (Fig. 24). Each tooth was then evaluated at the occlusal enamel margin and at the cervical dentine margin for microleakage using a light microscope at 50x magnification. Microleakage was evaluated by two independent evaluators and scores were allocated according to Table IV and as shown in Figure 25. The data obtained was analyzed using the Kruskal-Wallis test, with Fisher's least significant difference method utilized for comparison of specific groups ($p < 0.05$).



**Fig. 22: Resin embedded tooth with restored cavity
after basic Fuchsin^u treatment**



Fig. 23: Re-embedded tooth. Ready for longitudinal sectioning

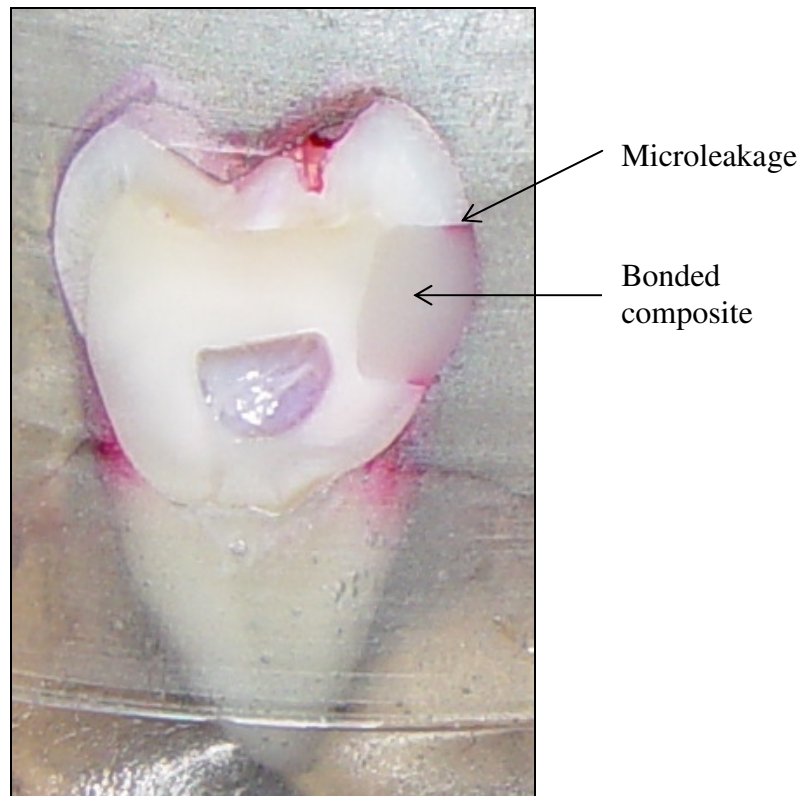

Fig. 24: Sectioned tooth. Ready for microleakage evaluation

SCORING – Incisal Enamel and Apical Dentine Margins

- Score 0** No Dye penetration (No leakage)
- Score 1** Less than and upto one-third the depth of the preparation penetrated by the dye
- Score 2** More than one third and less than or upto two thirds the depth of the preparation penetration by the dye
- Score 3** More than two thirds and less than or upto the junction of the gingival wall and axial wall of the preparation penetration by the dye
- Score 4** Dye penetration including the axial wall

** Both halves of each sectioned tooth were examined. If the scores were found to be different, the higher score was recorded.

Table IV: Criteria for scoring microleakage

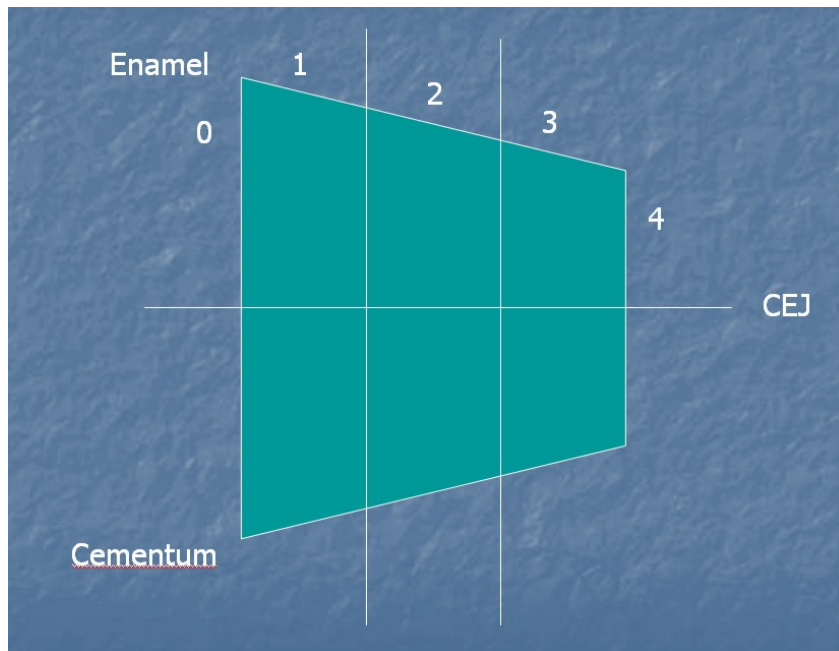

Fig. 25: Cavity indicating microleakage scoring criteria

3.3. *In-vitro* Anti-Bacterial Efficacy

Scotchbond Multipurpose Plus^a, ABF^b and Clearfil SE Bond^c were chosen for this part of this study. Scotchbond Multipurpose Plus^a was used as control with Clearfil SE Bond^c as representative of self-etching bonding agents and ABF^b as a product specifically marketed as a self-etching, ‘anti-bacterial’ bonding agent.

The major components of the three products tested are listed below:

Scotchbond Multipurpose Plus^a:

- Aqueous solution of HEMA
- Copolymer of Acrylic and Itaconic acids
- Bisphenol A Diglycidyl Ether Dimethacrylate (BISGMA)

ABF^b:

- MDPB (12-Methacryloyloxydodecylpyridinium bromide)
- MDP (10-Methacryloyloxydecyl dihydrogen phosphate)
- HEMA (2-hydroxyethylmethacrylate)
- di-Camphorquinone
- N,N-Diethanol-p-toluidine
- Water

Clearfil SE Bond^c:

- MDP (10-methacryloyloxydecyl dihydrogen phosphate)
- HEMA (2-Hydroxyethyl methacrylate)
- Hydrophilic dimethacrylate
- di-Camphorquinone
- N,N-Diethanol-p-toluidine
- Water

The bacteria *Streptococcus mutans* (ATCC 25175), *Lactobacillus paracasei* (A54) and *Actinomyces naeslundii* (NCTC 10301) were chosen as representative species of bacteria often involved in the carious process.¹⁴⁹

Suspensions of test organisms were prepared in quarter strength Ringer solution until turbidity compatible with a 0.5 MacFarland was obtained (DIFCO Laboratories, Baltimore, USA). The resulting organism concentrations were approximately $1-2 \times 10^8$ CFU/ml. The suspension (0.1ml) was spread onto selective agar by means of the standardized glass spreading technique.¹⁷² Brain-Heart infusion agar was used for the

Streptococcus and the *Actinomyces* species, and Rogosa agar was used for the *Lactobacillus*. The plates were incubated at 37°C for 15 minutes before application of the test materials. Twenty µl each of the test materials were placed on filtration paper disks (Whatman grade 41, size Ø 20mm). To prevent the solvents from having an anti-bacterial effect, the solvents in the test materials were allowed to evaporate completely before the paper disks were placed on the agar plates. For each product, five agar plates were prepared and two paper disks placed on each agar plate (Fig.26).

The plates were incubated at 37°C for 24hr, 48hr and 72hr respectively. *Actinomyces* and *Lactobacillus* were incubated in anaerobic conditions (Anaerocult A; Merck, Johannesburg, RSA).

The antibacterial activity was evaluated using the conventional agar plate diffusion method.^{173,174} The antibacterial activity of materials was apparent from circular clear zones of inhibition ('halos') around the filtration paper disks (Fig. 26). The inhibition zones were measured using a micrometer gauge. Measurements were taken after each incubation period at three different positions for each paper disk (From border of disk to end of halo at A,B,C : Fig. 26), and an average for the six measurements per plate for the five plates per product were calculated and the data analyzed using the Student t-test to determine significant differences.

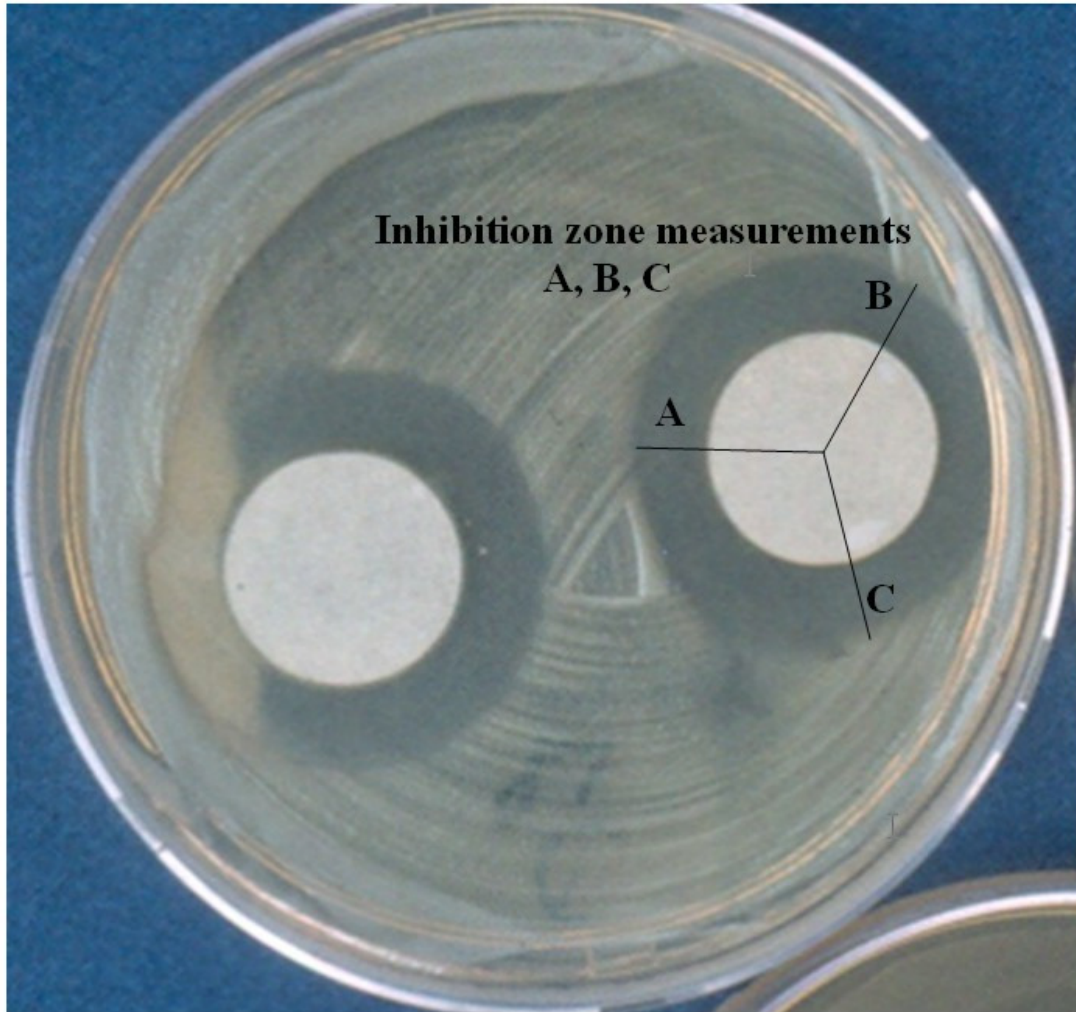

Fig. 26: *S. mutans* inhibition by ABF primer

4. Results

4.1 *In-vitro* Shear Bond Strength Evaluation

In this study Clearfil SE Bond^c produced the highest dentine shear bond strength followed by ABF^b and Optibond Solo Self-etch^e. These three products demonstrated statistically comparable shear bond strength values to the control, Scotchbond Multipurpose Plus^a, and also demonstrated significantly higher bond strengths than XENO III^d and Adper Prompt-L-Pop^f (*Table V*).

	Average shear bond strength (MPa)	Std deviation (MPa)
Scotchbond MP ⁺ (Control)	24.1	7.6
Clearfil SE Bond	26.2	7.8
ABF (Clearfil Protect Bond)	25.9	4.3
Optibond Solo Self-etch	21.9	3.9
Xeno III	17.3 [*]	4.1
Adper Prompt-L-Pop	15.4 [*]	3.1

- Significantly different from the Control at $p < 0.05$

Table V: Dentine shear bond strength values

Further statistical analysis indicated that Xeno III^d demonstrated comparable bond strengths to Adper Prompt-L-Pop^f (Xeno III bond strengths were slightly higher than that of Adper Prompt-L-Pop).

4.2. *In-vitro* Microleakage Evaluation

Incisal Enamel Margins (Table VI)

Results for microleakage at the incisal enamel margins indicated significantly different leakage values from the control, Optibond Solo Plus Self-Etch^p, Xeno III^d, OneCoatSE Bond^q and iBond^f. Enamel margin microleakage values for Clearfil SE Bond^c and ABF^b did not significantly differ from the control Scotchbond Multipurpose Plus^a. Enamel margin microleakage values for Xeno III^d, OneCoatSE Bond^q and iBond^f did not significantly differ from each other.

	0	1	2	3	4	Sum of Scores	Median Score
Scotchbond (Control)	4	5	1	-	-	7	1
SE Bond	3	3	4	-	-	11	1
ABF	5	2	3	-	-	8	0.5
OptibSoloSE	1	5	3	-	1 ⁺	15	1*
OneCoatSE	-	3	6	-	1	19	2*
Xeno III	-	1	8	1	-	20	2*
iBond	-	4	5	-	1	18	2*

* Significantly different from Control at P<0.05

Table VI: Microleakage evaluation at the incisal ENAMEL margins

Apical Dentine Margins (Table VII)

Results for microleakage at the Apical Dentine margins indicated significantly different leakage values compared to the control, for Optibond Solo Plus Self-Etch^p, Xeno III^d and OneCoatSE Bond^q. Dentine margin microleakage values for Clearfil SE Bond^c, ABF^b and iBond^f did not significantly differ from the control, Scotchbond Multipurpose Plus^a.

	0	1	2	3	4	Sum of Scores	Median Score
Scotchbond (Control)	4	3	-	2	1	13	1
SE Bond	6	1	-	2	1	11	0
ABF	7	-	-	1	2	11	0
OptibSoloSE	2	2	2	1	3	21	2*
OneCoatSE	1	4	1	-	4	22	2*
Xeno III	2	1	-	-	7	29	3*
iBond	4	3	1	-	2	13	1

* Significantly different from Control at P<0.05

Table VII: Microleakage evaluation at the apical DENTINE margins

4.3. *In-vitro* Anti-Bacterial Efficacy

The analyzed data for the inhibition zones for the 3 different primers are given in Table VIII. All three primers showed zones of inhibition for all three species of bacteria tested. The zone of inhibition for Scotchbond Multipurpose Plus^a primer was

very small for *L. paracasei* and in some areas barely detectable. Inhibition zones resulting from Scotchbond Multipurpose Plus^a primer for *A. naeslundii* was not significantly different ($P>0.05$) compared with ABF^b, but both Scotchbond Multipurpose Plus^a and ABF^b primers showed significantly better inhibition ($P<0.05$) than the Clearfil SE Bond^c primer.

Inhibition zones for ABF^b primer against *S. mutans* were significantly better ($p< 0.05$) than Scotchbond Multipurpose Plus^a and Clearfil SE Bond^c. Inhibition zones of Clearfil SE Bond^c primer were significantly smaller ($p<0.05$) than that of the ABF^b primer for *S. mutans* and *A. naeslundii*, but for *L. paracasei* no significant difference in inhibition zones were detected ($p>0.05$). (See Table IX for results of the statistical analysis of the data).

<u>Product</u>	<u><i>S. mutans</i></u> <u>[mm]</u>	<u><i>A. naeslundii</i></u> <u>[mm]</u>	<u><i>L. paracasei</i></u> <u>[mm]</u>
<u>ABF</u>	6.50 ± 0.8	8.33 ± 2.3	7.33 ± 1.3
<u>SE Bond</u>	2.00 ± 1.1	2.00 ± 0.9	7.58 ± 0.6
<u>SBMP⁺</u>	3.67 ± 1.3	7.50 ± 2.4	0.50 ± 0.2

Table VIII: Mean inhibition zones (mm) for the primers of the three different bonding systems tested against the three test organisms

	SE Bond -primer	ABF - primer
Scotchbond MP⁺ -primer	S.m.: p<0.05 L.p.: p<0.05 A.n.:p<0.05	S.m.: p<0.05 L.p.: p<0.05 A.n.: p>0.05
Clearfil SE Bond -primer		S.m.: p<0.05 L.p.: p>0.05 A.n.: p<0.05

Table IX: Statistical comparison (Student-t test) of primers to indicate significant differences (p<0.05) in the anti-bacterial inhibition of *S.mutans* (S.m), *L. paracasei* (L.p) and *A. naeslundii* (A.n).

5. Discussion

5.1. *In-vitro* Shear Bond Strength Evaluation

Scotchbond Multipurpose Plus^a has been used as control in many *in-vitro* and *in-vivo* shear bond strength tests and it can be stated that if a product compares favourably to Scotchbond Multipurpose Plus^a then it should be acceptable for clinical use^{33-35,37,94}. Clearfil SE Bond^c is also one of the first self-etching bonding agents and already has a proven track record lasting at least ten years and is consistent in its high values for bonding to enamel and dentine.^{102, 175-185} ABF^b has subsequently been launched in the market as Clearfil Protect Bond^b, a self-etching, anti-bacterial, fluoride-releasing, dentine bonding agent.

Since the phosphoric acid etching step is eliminated when using self-etching dentine bonding agents, tooth structure is etched less aggressive than when using total-etch dentine bonding agents. This fact led to concerns about enamel etching and etching patterns of self-etching systems, which in turn resulted in more studies being done on enamel shear bond strength than studies done on dentine shear bond strength.¹⁸⁶⁻¹⁹⁴ These studies address the concern that the ‘less aggressive’ etching of enamel by self-etching dentine bonding agents might result in lower bond strength and higher microleakage. In the current study the author decided to evaluate only dentine shear bond strength.

Self-etching dentine bonding systems are composed of aqueous mixtures of acidic functional monomers, commonly phosphoric acid- or carboxylic acid-esters. These

self-etching dentine bonding agents are classified by some in three categories according to their acidity: mild, moderate and aggressive.¹⁹⁵ Different self-etching dentine bonding agents will therefore etch tooth structure differently, which may influence both hybrid layer formation and bonding to enamel and dentine, and possibly influence microleakage values as well. A dentine bonding agent such as Prompt-L-Pop^w (and the later generation Adper Prompt-L-Pop^f) is considered to be an ‘aggressive’ self-etching product. This product dissolves the smear layer and smear plugs and form hybrid layers resembling those seen with total-etch dentine bonding agents.⁵⁸ This ‘total-etch like’ hybrid layer does, however, not mean that its bond strength values are similar to that of the total-etch bonding systems. Clearfil SE Bond^c, a ‘mild’ self-etching bonding agent normally achieves higher bond strength values to both dentine and enamel when compared to Prompt-L-Pop^w.^{33,58,177} Sundfeld *et. al.* (2005),¹⁹⁶ investigated hybrid layer formation and resin tag length for Prompt-L-Pop^w and compared it to dentine previously acid etched with 37% phosphoric acid. Similar resin tags were found for all study groups, indicating that hybrid layer and resin tag formation are not indicative of high bond strength to dentine. Although Prompt-L-Pop^w, as an example of an aggressive self-etching dentine bonding agent was not included in the study, the literature (as described above) indicates that acidity and acid-etching are not the sole factors responsible for a high, comparative, dentine bond strength.

The shear bond strength values achieved in the present study for SE Bond^c, ABF^b, Optibond Solo Self-etch^e and the control Scotchbond Multipurpose Plus^a (table V), compare well with the values of other traditional total-etch dentine bonding agents evaluated by Leirskar *et. al.* (1998).¹⁹⁷ Using Clearfil SE Bond^c, Inoue *et. al.* (1999),⁶⁸

reported a shear bond strength of 39 MPa to dentine, Miranda *et. al.* (2006)¹⁹⁸ reported a shear bond strength of only 16.13 MPa to primary dentine and Kaaden *et. al.* (2002),¹⁹⁹ reported a shear bond strength of 27.3 MPa to superficial dentine. In the present study the author obtained a mean shear bond strength of 26.2 MPa to dentine with the Clearfil SE Bond^c system. The experimental product ABF^b showed comparable dentine bond strengths to both Clearfil SE Bond^c as well as the control, Scotchbond Multipurpose Plus^a.

Some other studies were also performed to compare dentine bond strength of self-etching dentine bonding agents with total-etch dentine bonding systems. In a study by Bonilla *et. al.* (2003),²⁰⁰ it was shown that Clearfil SE Bond^c, as example of a self-etching dentine bonding agent, bonded to dentine with a bond strength which was statistical comparable to some total-etch dentine bonding agents. In a microtensile dentine bond strength test, the self-etching dentine bonding agent Clearfil SE Bond^c bonded statistically higher to dentine, for both the total-etch systems Adper Scotchbond Multipurpose Plus^a and Optibond Fl (Kerr corporation).³⁶ Although that study showed no evidence of significant relationships between microtensile bond strength and microleakage, Clearfil SE Bond^c still displayed the highest dentine bond strength and the lowest leakage of the three dentine bonding agents evaluated. In this study it was also found that Clearfil SE Bond^c reached the highest dentine bond strength when compared to total-etch systems.³⁶ Kiremitçi *et. al.* (2004),²⁰¹ evaluated bonding to enamel and dentine using Clearfil SE Bond^c, comparing it to the total-etch dentine bonding agent Prime & Bond NT (Dentsply).

Another relevant factor to be considered is the fact that Clearfil SE Bond^c and ABF^b (Clearfil Protect Bond) are two bottle systems (two-step, self-etch). In a study done by Proença *et. al.* (2007),²⁰² dentine bond strength of self-etching as well as total-etch adhesive systems were evaluated. It was reported that Clearfil SE Bond^c exhibited a statistically higher dentine bond strength for all areas of dentine when compared to one bottle, total-etch dentine bonding agents and also statistically higher than one bottle, self-etch dentine bonding agents.²⁰²

A study which raises concern for the long-term stability of self-etching bonds was done by Reis *et. al.* (2005).³⁷ In this study the immediate dentine bond strength for both Clearfil SE Bond^c and Adper Scotchbond Multipurpose Plus^a was statistically similar, but the 6 month bond strength data indicated a marked drop in bond strength for Clearfil SE Bond^c, whilst Adper Scotchbond Multipurpose Plus^a showed a slight increase in bond strength.³⁷ Adper Scotchbond Multipurpose Plus^a is more hydrophobic than most self-etching products. It is postulated that the high polarity, more hydrophilic monomers of self-etching systems might be prone to long-term hydrolytic degradation.^{203,204} Although some authors did not report this drop in bond strength, the long-term stability concerns remain valid, and more long-term studies are needed.

In a study by Sengün *et. al.* (2002),²⁰⁵ on bonding to normal and caries-affected dentine, Clearfil SE Bond^c bonded statistically higher to most, and similar to some of the total-etch dentine bonding agents. In another study comparing bonding to carious

dentine no statistical difference in bond strength between the total-etch product Adper Single Bond (3M ESPE) (one bottle) and the self-etch product ABF^b was found.²⁰⁶

The author's study evaluated immediate shear bond strength to superficial human dentine. Many other studies on dentine bonding using self-etching bonding systems are available which also supports the view that some self-etching systems may be a clinically acceptable alternative to total-etch systems. Bekes *et. al.* (2007),²⁰⁷ evaluated the clinical performance over two years of total-etch and self-etching products and concluded that the systems tested demonstrated a very good clinical performance in the restoration of class I and II restorations.²⁰⁷ A study by Breschi *et. al.* (2008),²⁰⁸ investigated the latest peer reviewed reports related to formation, aging and stability of resin bonding. Those studies indicated that the long-term stability of simplified one-bottle systems are a cause for concern, but that two-bottle self-etching systems (two-step, self-etching) and two bottle total-etch dentine bonding agents (three-step, etch-and-rinse) showed the best clinical performance.²⁰⁸ An article by Donmez *et. al.* (2005),²⁰⁹ however, questions the long term stability of all self-etching bonds due to possible 'water tree' formation and the possibility of subsequent hydrolytic degradation of these bonds. Many other articles also focus on long-term stability of these 'hydrophilic' self-etching bonds, with most concerns focussed on single-step/one-bottle systems, but some also on two-bottle self-etching systems such as Clearfil SE Bond^c. 'Water tree' formation and 'nanoleakage' into hybrid layers formed by self-etching bonding systems may make these hybrid layers prone to long-term hydrolytic attack which could cause early bond failure.²¹⁰⁻²¹⁴

It is interesting to note that both Scotchbond Multipurpose Plus^a and SE Bond^c are two-bottle systems incorporating a viscous, hydrophobic resin as adhesive (bonding) resin. ABF^b has a similar consistency, and high shear bond values, comparable to Clearfil SE Bond^c. The products Xeno III^d and Adper Prompt-L-Pop^f are both pre-mixed before application and have a higher viscosity. When applied both produce a visibly thinner layer of bonding agent, especially when air-thinned. Using these and other products in previous shear bond strength evaluations the authors have observed that products with higher viscosity consistently produced lower values in shear bond strength tests. These products were also more sensitive to variation in application techniques.

5.2. *In-vitro* Microleakage Evaluation

Microleakage study results vary for different products, but of relevance is the fact that most studies show no direct link between bond strength and microleakage.^{36,133} The highest bond strength therefore does not mean the product will have the lowest microleakage. But, as mentioned, bonding to enamel remains a concern and quite a few research articles query the efficacy of self-etching enamel bonding and provide conflicting results, specifically for enamel microleakage.^{102,110,121,215,216}

In order to evaluate bond strength and microleakage under conditions simulating the oral cavity some authors make use of thermal cycling (thermocycling) or load cycling regimes as part of their studies. Thermal cycling was used in this project. Thermal cycling attempts to simulate the influence of either hot or cold conditions, as found *in-vivo*, on the restoration. Regimes vary considerably in the literature with variations in

temperature, immersion and dwell times, as well as the number of times the restorations are 'cycled'. For the purpose of this study the author chose a regime which was compatible to the equipment available (The teeth were thermocycled between 5° C and 60° C ($\pm 2^\circ$ C) for 250 cycles with a dwell time of 20 seconds).¹⁷¹

As an example of the variations in thermocycling regimes the following studies are highlighted. Eminkahyagil *et. al.* (2005),²¹⁷ thermocycled teeth for 500 cycles between 5° C and 55° C with a dwell time of 30 seconds, while Toledano *et. al.* (2000),²¹⁸ thermocycled teeth between 5 ° C and 55° C (with no mention of dwell times). Pradelle-Plasse *et. al.* (2001),¹²¹ thermocycled teeth for 2200 cycles between 5° C and 55° C with a dwell time of 10 seconds, Ernst *et. al.* (2002),¹⁰² used 5000 cycles between 5° C and 55° C, with a dwell time of 30 seconds.

De Munck *et. al.* (2005),²¹⁹ subjected dentine bonds in class one cavities to 20000 cycles using a two-step self-etch bonding agent and a three-step total-etch dentine bonding agent. A noteworthy conclusion of their research was that thermocycling did not enhance chemical or mechanical degradation of the bonds. In an article on the effect of thermocycling times on dentine bond strength, Burger *et. al.* (1992),¹⁷¹ found no significant difference between the groups evaluated. They evaluated shear bond strength to dentine and used cycles of 100, 500, 1000, 2000 and 4000. More research on the effect of different thermocycling regimes on microleakage, for both self-etch and total-etch dentine bonding agents, needs to be performed. Comparing the effect of thermocycling on shear bond results versus micro-tensile results will also be of interest.

The huge number of variables in dental materials research remains a problem and all results from studies need to be considered - taking into account the variables involved. As previously mentioned, results often cannot be interpreted as 'absolutes' but need to be compared with all other available research and conclusions need to be drawn regarding the 'trends'. Very few research projects are available where the products, apparatus, regimes, conditions ea. are all similar. In the author's research on shear bond strength and microleakage no other publications evaluating the same products, under the same possible variables, could be found.

Measuring/evaluating microleakage can be done using a variety of techniques - as described in the literature. For the purpose of the author's study a dye leakage technique was followed (All seven groups were placed in a 0.5% basic Fuchsin^h solution for 12 hours at 37° C). A study of the literature indicates a variety of 'dyes' being used as well as dye submersion/exposure regimes. Bortolotto *et. al.* (2008),²²⁰ used an aqueous solution of 50 wt% ammoniacal silver nitrate and teeth were immersed for 24 hours, Ferrari *et. al.* (2000),²²¹ in turn, immersed samples in a 2% methylene blue solution at room temperature for 24 hours, Rossomondo *et. al.* (1995),¹²² used basic fuchsin dye (The concentration was not specified) and the restorations were immersed for up to 160 hours for the duration of 5000 cycles. Toledano *et. al.* (2000),²¹⁸ used 0.5% basic fuchsin and immersed the restorations in the dye for a period of 24 hours. These are but a few of the variations described in the literature.

In this current study an attempt was made to standardize the cavity size by using a standard sized Cerano^o inlay bur. Polymerization contraction (shrinkage) generated by

composite at the bonding interface, has been reported to increase as the C-factor increases.²²² Also applicable is the magnitude of the contraction stress, a factor which is dependant on the composite itself and the volume or thickness of that specific composite.^{12,223} In this study the relatively large cavity size and geometry probably resulted in high shrinkage forces and a high configuration factor, but since the cavity size was kept constant and the bonding agents were compared with each other, this fact would not have influenced the results and the final outcome of this study. Overall high leakage values could have been expected, as was indeed the case.

It has been determined that the time immediately following placement of the restoration is critical since enamel and dentine bonding must counteract the composite shrinkage.⁹ The author decided, for this part of the study, to allow the prepared and subsequently restored cavities to mature overnight in distilled water before thermocycling. This ‘maturing’ was allowed to ensure optimal polymerization and stress distribution during this critical part of polymerization, before final immersion in dye.²²⁴ Although the bond strength values seem to be adequate, marginal leakage at the dentine and enamel margins could not be prevented. Overall, the results of this study seem to correlate well with similar studies reported in the literature.²²⁵⁻²²⁷ Although not always the case, it has been confirmed in the present study, that there is a relationship between microleakage values and bond strength values. Results in the literature vary but some correspond with the results obtained by the author (Table X).²²⁸⁻²³⁰

Because the bond to acid etched enamel is normally stronger than to dentine, an interfacial gap is likely to form (due to polymerization shrinkage of composite resin)

at the gingival cementum (apical dentine) margins.²³⁰ The bonding substrate at the gingival margins consists of an outer layer, 150-400µm thick, partially formed by cementum. This hypo-mineralized, hyper-organic substrate, even after etching, does not allow good infiltration by adhesive materials.¹⁶⁵ The results of this study with self-etching systems also indicate better sealing at the enamel margins, both for the control as well as for the self-etching systems as a group (Table X).

	Enamel	Dentine	Dentine
	Sum of Scores	Sum of Scores	MPa
Scotchbond (Control)	7	13	24.9
SE Bond	11	11	26.2
ABF	8	11	25.9
OptibSoloSE	15	21	21.9*
OneCoatSE	19	22	-
Xeno III	20	29	17.3*
iBond	18	13	-
	T: 98	T: 120	
	SE ave: 15.2	SE ave: 17.8	

Table X: Enamel and dentine leakage scores compared to dentine shear bond strength evaluation* .

5.3. *In-vitro* Anti-Bacterial Efficacy

Secondary caries remain one of the main reasons for the replacement of restorations.²³¹ Thus, the ability of any material to inhibit secondary caries formation is an important clinical therapeutic property and it is therefore obvious that any material which will inhibit bacteria, and/or re-mineralize tooth structure through fluoride release, will be a major factor in the prevention of further tooth decay.

The author's evaluations on shear bond strength and microleakage both indicated that some self-etching bonding systems compare favourably to the more traditional total-etch systems. But, it has also shown that microleakage gaps could not be prevented with any of the systems evaluated. This led to the author's anti-bacterial study which aimed to identify products with possible anti-bacterial properties that could possibly prevent or limit bacterial penetration, or delay bacterial proliferation.

Various researchers have published studies on the anti-bacterial properties of current dentine bonding agents and/or composites.^{146,155,158,163,229-231} Although self-etching bonding systems are relatively new, some have proven themselves clinically and according to studies also possess some anti-bacterial properties.^{106,232,233} The current study confirmed this.

For several decades *Streptococcus* has been seen as the most important caries forming bacteria and much research has been done to find methods of either limiting its colonization, or immunization against its prevalence.²³⁴ The latest research seems to

point at the role of a variety of bacteria involved in caries development and progression.¹⁰⁶ Limiting one species of bacteria alone might not result in caries inhibition as this might give other species the opportunity to multiply readily and continue the carious process. Although self-etching bonding systems are relatively new, some have already proven themselves clinically.^{105,235,236} It seems as if the manufacturers of the new product ABF^b / Clearfil Protect Bond^b attempted to include the proven advantages of fluoride (in the adhesive) as an ingredient, coupled with an additional anti-bacterial agent (in the primer). This might limit or delay bacterial proliferation in microleakage gaps (which we know are present in most restored teeth).

During 1996 Holmgren and Pilot published a “Preliminary Research Agenda for Minimal Intervention Techniques for caries”.²³⁷ One of the research agendas on the list covers the problem of microleakage and bacterial inhibition, explaining how improved new materials offers biocompatibility, may prevent the onset of caries and/or progression, improve re-mineralization, and may also be bacteriostatic. With the high likelihood of some form of microleakage, and accompanying secondary caries due to bacterial proliferation, it seems logical that any anti-bacterial product that might limit or control bacteria in and around the cavity, may extend the life expectancy of any restoration considerably.^{237,238,240}

According to a study done by Imazato *et. al.* in 2001 on anti-bacterial properties of dentine bonding agents, the primer of the product ABF^b was found to be the most bactericidal among the materials tested.¹⁶⁹ The authors found that the ingredient MDPB (as found in ABF^b) could be beneficial in eliminating the residual bacteria

often found in cavities. Karanika-Kouma *et.al.* (2001),¹⁴⁰ tested the anti-bacterial properties of various bonding agents against cariogenic bacteria, and found various degrees of anti-bacterial activity against all the test bacteria. Various other authors concluded that ‘anti-bacterial’ properties of tested adhesives might reduce the consequences of microleakage owing to their anti-bacterial properties .^{153,240,241}

In this study the primer of ABF^b was significantly more effective in inhibiting *S. mutans* than both Scotchbond Multipurpose Plus^a and Clearfil SE Bond^c. ABF^b did have a notable inhibitory effect on both *A. naeslundii* and *L. paracasei* but was only statistically more effective against *A. naeslundii* when compared with Clearfil SE Bond^a primer and statistically more effective against *L. paracasei* when compared with Scotchbond Multipurpose Plus^a primer. The results of this study provided evidence that ABF^b had a significant anti-bacterial efficacy against the spectrum of bacterial species included in this study. These results corresponds to findings from other authors that ABF^b has an anti-bacterial efficacy against organisms which may be found in microleakage gaps.^{140,169}

6. Conclusions

6.1. *In-vitro* Shear Bond Strength Evaluation

In this study three of the five self-etching bonding systems bonded statistically comparable to the total-etch control (Table IV). Some of the self-etching bonding systems tested seem to be viable alternatives for clinical use compared to the more ‘traditional’ and proven types of dentine bonding agents, such as Scotchbond Multipurpose Plus^a.

It may be relevant that the use of a viscous, hydrophobic adhesive resin, following the primer or self-etching primer, is important in obtaining consistent high shear bond strength values. Further studies need to be done on the technique sensitivity of these products, the long-term clinical value of “high” or “low” shear bond strength values and the long term efficacy of these bonds to dentine.

Since different products were evaluated under different experimental conditions these studies do not indicate that all self-etching dentine bonding agents will achieve a higher dentine bond strength and lower microleakage than total-etch dentine bonding agents. The author’s research indicates high values for Clearfil SE Bond^c and Clearfil Protect Bond^b (ABF) specifically, and indicates that some self-etching systems compare favourably to total-etch dentine bonding agents. Many studies are available, some with contradictory results to that of the author. But by far the majority of studies showed that most self-etching dentine bonding agents bond well to dentine, some even better than the traditional total-etch dentine bonding agents.

6.2. *In-vitro* Microleakage Evaluation

In this project both Clearfil SE Bond^c and ABF^b (Clearfil Protect Bond) achieved statistically comparable microleakage values for both enamel and dentine when compared to Adper Scotchbond Multipurpose Plus^a, a well researched and proven fourth generation (total-etch) dentine bonding agent. The results of this study compare well with research done by other workers in the field and private practitioners can be advised, that as far as marginal leakage is concerned, SE Bond^c and ABF^b (Clearfil Protect Bond) self-etching bonding agents are viable alternatives for clinical use compared to clinically proven products such as Scotchbond Multipurpose Plus^a.

More research needs to be done on enamel bond strength and sealing of enamel margins when using self-etching systems, as well as on the long term stability of self-etching bonds. Factors relating to sealing and bonding the ‘difficult to etch’ apical cementum/dentine margin areas in class V restorations, using self-etching systems, also need to be investigated in more detail.

6.3. *In-vitro* Anti-Bacterial Efficacy

The results of this study did provide evidence that ABF^b had a significant anti-bacterial efficacy against the spectrum of bacterial species included in this study.

Since it was noted that ABF^b effectively inhibited all three species of bacteria included in this study, this spectrum of anti-bacterial efficacy should be beneficial in

limiting secondary caries formation and/or progression. Further research needs to be done on the anti-bacterial properties of MDPB containing primers, especially the long-term anti-bacterial efficacy on a greater variety of organisms, which might play a part in the onset and progression of caries. It is unclear if these anti-bacterial properties will act in the long-term and whether it will have any real clinical advantage when compared to other bonding agents.

6.4. General Conclusions

The studies performed by the author achieved comparative/similar results to some studies described in the literature but it is clear from the literature that some studies provide conflicting results, especially leakage of enamel margins when using self-etching bonding agents.^{101, 120,242-244}

Taking into consideration the limitations of the three studies performed, it can be concluded that as far as the three evaluated properties of self-etching dentine bonding agents are concerned, they should prove to be acceptable clinical alternatives for use in place of total-etch dentine bonding agents.

7. References

1. http://www.ada.org/public/resources/history/timeline_ancient.asp.
History of Dentistry: Ancient Origins and Middle Ages-Renaissance.
2. Söderholm KJ. Dental adhesives How it all started and later evolved.
J Adhes Dent 2007;**9** Suppl2:227-230.
3. Buonocore MG. A simple method of increasing the adhesion of acrylic filling materials to enamel surfaces. *J Dent Res* 1955;**34**:849-853.
4. Buonocore MG, Matsui A, Gwinnett AJ. Penetration of resin dental materials into enamel surfaces with reference to bonding. *Arch Oral Biol* 1968;**13**:61-70.
5. Gwinnett AJ, Matsui A. A study of enamel adhesives. The physical relationship between enamel and adhesive. *Arch Oral Biol* 1967;**12**:1615-1620.
6. Buonocore M, Wileman W, Brudevold F. A report on a resin composition capable of bonding to human dentin surfaces. *J Dent Res* 1956;**35**:846-851.
7. Bowen RL. Adhesive bonding of various materials to hard tooth tissues.
II. Bonding to dentin promoted by a surface active comonomer.
J Dent Res 1965;**44**:895-902.
8. Jendresen MD. Clinical performance of a new composite resin for Class V erosion [abstract 1057]. *J Dent Res* 1978; **57**:339.
9. Flynn M. Six-year evaluation of in-vivo performance of cervical restorative materials [abstract 322]. *J Dent Res* 1982;**61**:214.
10. Eliades GC, Caputo AA, Vougiouklakis GJ. Composition, wetting properties and bond strength with dentin of 6 new dentin adhesives.
Dent Mater 1985;**1**:170-176.

11. Causton BE. Improved bonding of composite restorative to dentine.
Br Dent J 1984;**156**:93-95.
12. Davidson CL, de Gee AJ, Feilzer A. The competition between the composite-dentin bond strength and the polymerization contraction stress.
J Dent Res 1984;**63**:1396-1399.
13. Munksgaard EC, Irie M, Asmussen E. Dentin-polymer bond promoted by Gluma and various resins. *J Dent Res* 1985;**64**:1409-1411.
14. Barkmeier WW, Cooley RL. Resin adhesive systems: In vitro evaluation of dentin bond strength and marginal microleakage.
J Esthet Dent 1989;**1**:67-72.
15. Eliades GC, Vougiouklakis GJ. P-NMR study of P-based dental adhesives and electron probe microanalysis of simulated interfaces with dentin.
Dent Mater 1989;**5**:101-108.
16. Yu XY, Joynt RB, Wieczkowski G, Davis EI. Scanning electron microscopic and energy dispersive x-ray evaluation of two smear layer-mediated dentinal bonding agents. *Quintessence Int* 1991;**22**:305-310.
17. Erickson RL. Mechanism and clinical implications of bond formation for two dentin bonding agents. *Am J Dent* 1989;**2**:117-123.
18. Retief DH. Adhesion to dentin. *J Esthet Dent* 1991;**3**:106-113.
19. Chappel RP, Eick JD, Theisen FC, Carracho AJL. Shear bond strength and scanning electron microscopic observation of current dentinal adhesives.
Quintessence Int 1991;**22**:831-839.
20. Dickinson GL, Stevens JT, Overberger JE, McCutcheon WR. Comparison of shear bond strengths of some third-generation dentin bonding agents.
Oper Dent 1991;**16**:223-230.

21. Barkmeier WW, Cooley RL. Resin adhesive systems. In vitro evaluation of dentin bond strength and marginal microleakage.
J Esthet Dent 1989;**1**:67-72.
22. Barkmeier WW, Cooley RL. Shear bond strength and marginal microleakage.
J Esthet Dent 1989;**2**:111-115.
23. Prati C, Nucci C, Montanari G. Shear bond strength and microleakage of dentin bonding systems. *J Prosthet Dent* 1991;**65**:401-407.
24. Retief DH, Madras RS, Russel CM, Denys FR. Evaluation of the Syntac bonding system. *Am J Dent* 1993;**6**:17-21.
25. Swift EJ, Hansen SE. Effect of new bonding systems on microleakage.
Am J Dent 1989;**2**:77-80.
26. Swift EJ. Microleakage of dentin adhesive systems.
J Esthet Dent 1991;**3**:91-94.
27. Fissore B, Nicholls JI, Yuodelis RA. Load fatigue of teeth restored by a dentin bonding agent and a posterior composite resin.
J Prosthet Dent 1991;**65**:80-85.
28. Duke ES, Robbins JW, Snyder DS. Clinical evaluation of a dental adhesive system: three-year results. *Quintessence Int* 1991;**22**:889-895.
29. Fusayama T, Nakamura M, Kurosaki N, Iwaku M. Non-pressure adhesion of a new adhesive restorative system. *J Dent Res* 1979;**58**:1364-1370.
30. Kanca J. Bonding to tooth structure: A rational rationale for a clinical protocol. *J Esthet Dent* 1989;**1**:135-138.
31. Bertolotti RL. Total-etch – The rational dentin bonding protocol.
J Esthet Dent 1991;**3**:1-6.

32. Rathke A. Clinical aspects of dentin adhesives: principles, processing errors, perspectives. In: Ed. Oehri P. *Report - Research and Development, Ivoclar Vivadent AG* 2001;14.
33. Vargas MA, Cobb DS, Denehy GE. Interfacial micromorphology and shear bond strength of single-bottle primer/adhesives. *Dent Mater* 1997;**13**:316-324.
34. Toledano M, Osorio R, De Leonardi G, Rosales-Leal JI, Ceballos L, Cabrerizo-Vilchez MA. Influence of self-etching primer on the resin adhesion to enamel and dentine. *Am J Dent* 2001;**14**:205-210.
35. Torii Y, Itou K, Hikasa R, Iwata S, Nishitani Y. Enamel tensile bond strength and morphology of resin-enamel interface by acid etching system with or without moisture and self-etching priming system. *J Oral Rehab* 2002;**29**:528-533.
36. Guzmán-Armstrong S, Armstrong SR, Qian F. Relationship between nanoleakage and microtensile bond strength at the resin-dentin interface. *Oper Dent* 2003;**28**:60-66.
37. Reis A, Grandi V, Carlotto L, Bortoli G, Patzlaff R, Accorinte MDR, Loguercio AD. Effect of smear layer thickness and acidity of self-etching solutions on early and long-term bond strength to dentin. *J Dent* 2005;**33**:549-559.
38. Kugel G, Ferrari M. The science of bonding: From first to sixth generation. *JADA* 2000;**131**:20S-25S.
39. Nakabayashi N, Kojima K, Masuhara E. The promotion of adhesion by the infiltration of monomers into tooth states. *J Biomed Mat Res* 1982;**16**:265-273.
40. Kanca J. A method for bonding to tooth structure using phosphoric acid as a dentin-enamel conditioner. *Quintessence Int* 1991;**22**:285-290.
41. Gwinnett AJ. Quantitative contribution of resin infiltration/hybridization to dentin bonding. *Am J Dent* 1993;**6**(1):7-9.

42. Kanca J. Wet bonding: effect of drying time and distance.
Am J Dent 1996;**9**:273-276.
43. Gwinnett AJ, Tay FR, Wei SHY. Bridging the gap between overly dry and overwet bonding phenomenon of dentin hybridization and tubular seal.
In: Shmono M, Maeda T, Suda H, Takayashi K, eds. Dentin/pulp complex.
Tokyo: *Quintessence*;1996:359-363.
44. Latta MA. Clinical perspectives on current dental adhesives. 2008.
<http://www.ineedce.com/courses/1508/PDF/ClinicalPerspectives.pdf>
45. Ed. Jordan RE. *Esthetic Composite Bonding Techniques and Materials*.
Mosby Year Book, St. Louis, 1993.
46. Chappel RP, Cobb CM, Spencer P, Eick JD. Dentinal tubule anastomosis: a potential factor in adhesive bonding? *J Prosthet Dent* 1994;**72**:183-188.
47. Mjor IA, Nordhal I. The density and branching of dentinal tubules in human teeth
Arch Oral Biol 1996;**41**:401-412.
48. Titley K, Chercnecky R, Chan A, Smith DC. The composition and ultrastructure of resin tags in etched dentin. *Am J Dent* 1995;**8**:224-230.
49. Ferrari M, Goracci G, Garcia-Godoy F. Bonding mechanism of three “one-bottle” systems to conditioned and unconditioned enamel and dentin.
Am J Dent 1997;**10**:224-230.
50. Tay FR, Gwinnett AJ, Wei SHY. Structural evidence of a sealed tissue interface with total etch wet bonding technique, in vivo. *J Dent Res* 1994;**73**:629-636.
51. Chigira H, Koike T, Hasegawa T, Itoh K, Wakumoto S, Hayakawa T.
Effect of the self etching dentin primers on the bonding efficacy of a dentin adhesive. *Dent Mater* 1989;**8**(1):86-92.

52. Chigira H, Manabe A, Hasegawa T, Yukitani W, Fujimitsu T, Itoh K, Hisamitsu H, Wakumoto S. Efficacy of various commercial dentin bonding systems. *Dent Mater* 1994;**10(6)**:363-368.
53. Chigira H, Yukitani W, Hasegawa T, Manabe A, Itoh K, Hayakawa T, Debari K, Wakumoto S, Hisamitsu H. Self-etching dentin primers containing phenyl-P. *J Dent Res* 1994;**73(5)**:1088-1095.
54. Watanabe I, Nakabayashi N, Pashley DH. Bonding to ground dentin by a phenyl-P self-etching primer. *J Dent Res* 1994;**73(6)**:1212-1220.
55. Tay FR, Carvalho R, Sano H, Pashley DH. Effect of smear layers on the bonding of a self-etching primer to dentin. *J Adhes Dent* 2000;**2(2)**:99-116.
56. Moszner N, Salz U, Zimmerman J. Chemical aspects of self-etching enamel-dentin adhesives: a systematic review. *Dent Mater* 2005;**21**:895-910.
57. Tay FR, Sano H, Carvalho R, Pashley EL, Pashley DH. An ultrastructural study of the influence of acidity of self-etching primers and smear layer thickness on bonding to intact dentin. *J Adhes Dent* 2000;**2(2)**:83-98.
58. Tay FJ, Pashley DH. Aggressiveness of contemporary self-etching systems:
I: Depth of penetration beyond dentin smear layers. *Dent Mater* 2001;**17**:296-308.
59. Oliveira SAA, Pugach MK, Hilton JF, Watanabe LG, Marshall SJ, Marshall GW. The influence of the dentin smear layer on adhesion: a self-etching primer vs. a total-etch system. *Dent Mater* 2003;**19**:758-767.
60. Oliveira SAA, Marshall SJ, Habelitz S, Gansky SA, Wilson RS, Marshall GW. The effect of a self-etching primer on the continuous demineralization of dentin. *Eur J Oral Sci* 2004;**112**:376-383.
61. Clinician's preference 2001. *CRA Newsletter* 2001 Dec;**25(12)**.

62. Opdam NJ, Roeters FJ, Feilzer AJ, Verdonschot EH. Marginal integrity and postoperative sensitivity in Class 2 resin composite in vivo. *J Dent* 1998;**26**:555-562.
63. Perdigão J, Eriksson S, Rosa BT, Lopes M, Gomes G. Effect of calcium removal on dentin bond strengths. *Dent Res* 2001;**2**:142-146.
64. Maeda T, Yamaguchi K, Takamizawa T, Rikuta K, Tsubota K, Ando S, Miyazaki M. pH changes of self-etching primers mixed with powdered dentine. *J Dent* 2008;**36**:606-610.
65. Wang JD, Hume WR. Diffusion of hydrogen ion and hydroxyl ion from various sources through dentine. *Int Endod J* 1988;**21**:17-26.
66. Hiraishi N, Kitasako Y, Nikaido T, Foxton RM, Tagami J, Nomura S. Detection of acid diffusion through bovine dentine after adhesive application. *Int Endod J* 2004;**37**:455-462.
67. Camps J, Pashley DH. Buffering action of human dentin in vitro. *J Adhes Dent* 2000;**2**:39-50.
68. Inoue S, Van Meerbeek B, Vargas M, Lambrechts P, Vanherle G. Adhesion mechanism of self-etching adhesives. In: Tagami J, Toledano M, Prati C (eds). *Advanced Adhesive Dentistry Proceedings Book*. 3rd International Kuraray Symposium. Granada, 1999; December 3-4:131-148.
69. Van Meerbeek B, De Munck J, Yoshida Y, Inoue S, Vargas M, Vijay P, Van Landuyt K, Lambrechts P, Vanherle G. Adhesion to Enamel and Dentin: Current status and future challenges. *Oper Dent* 2003;**28**(3):215-235.
70. Yoshida Y, Nagakane K, Fukuda R, Nakayama Y, Okazaki M, Shintani L, Inoue S, Tagawa Y, Suzuki K, De Munck J, Van Meerbeek B. Comparative study on adhesive performance of functional monomers. *J Dent Res* 2004;**83**(6):454-458.

71. Yoshida Y, Van Meerbeek B, Nakayama Y, Snauwaert J, Hellemans L, Lambrechts P, Vanherle G, Wakasa K. Evidence of chemical bonding at biomaterial-hard tissue interfaces. *J Dent Res* 2000;**79(2)**:709-714.
72. Van Meerbeek B, Van Landuyt K, De Munck J, Hashimoto M, Peumans M, Lambrechts P, Yoshida Y, Inoue S, Suzuki K. Technique-sensitivity of contemporary adhesives. *Dent Mater* 2005;**24(1)**:1-13.
73. Nazarian A. The progression of Dental Adhesives, 2008.
<http://www.ineedce.com/courses/1496/PDF/TheProgressionofDentalAdhesives.pdf>
74. Duke ES. The Science and practice of dental adhesive systems. *Compend Contin Educ Dent* 2003;**24(6)**:417-419,421,423-424.
75. Going RE. Microleakage around dental restorations: a summarizing review. *J Am Dent Assoc* 1972; **84(6)**:1349-1357.
76. Kidd EA. Microleakage in relation to amalgam and composite restorations. A laboratory study. *Br Dent J* 1976;**141(10)**:305-310.
77. Øilo G. Adhesion of dental materials to dentin: Debonding tests. In: Thylstrup A, Leach SA, Qvist V, eds. *Dentine and Dentine Reactions in the Oral Cavity*. Oxford: IRL Press Ltd.1987:219-224.
78. Barkmeier WW, Cooley RL. Laboratory evaluation of adhesive systems. *Oper Dent* 1992; **5(Supp)**:50-61.
79. Irie M, Suzuki K, Watts DC. Immediate performance of self-etching versus adhesive systems with multiple light-activated restoratives. *Dent Mater* 2004;**20(9)**:873-880.
80. Ikeda T, De Munck J, Shirai K, Hikita K, Inoue S, Sano H, Lambrechts P, Van Meerbeek B. Effect of fracture strength of primer-adhesive mixture on bonding effectiveness. *Dent Mater* 2005;**21**:413-420.

81. Al-Salehi SK, Burke FJT. Methods used in dentin bonding tests: An analysis of 50 investigations on bond strength. *Quintessence Int* 1997;**28(11)**:717-723.
82. Pecora N, Yaman P, Dennison J, Herrero A. Comparison of shear bond strength relative to two testing devices. *J Prosthet Dent* 2002; **88(5)**:511-515.
83. Miyazaki M, Onose H, Moore BK. Effect of operator variability on dentin bond strength of two –step bonding systems. *Am J Dent* 2000;**13(2)**:101-104.
84. Söderholm KJ, Guelmann M, Bimstein E. Shear bond strength of one 4th and two 7th generation bonding agents when used by operators with different bonding experience. *J Adhes Dent* 2005;**7(1)**:57-64.
85. Pashley DH, Sano H, Ciucchi B, Yoshiyama M, Carvalho RM. Adhesion testing of dentin bonding agents: A review. *Dent Mater* 1995;**11**:117-125.
86. DeHoff PH, Anusavice KJ, Wang Z. Three-dimensional finite element analysis of the shear bond test. *Dent Mater* 1995;**11**:126-131.
87. Shell JS, Nielsen JP. Study of the bond between gold alloys and porcelain. *J Dent Res* 1962;**41**:1424.
88. Asgar K, Giday Z. Refinement on testing of porcelain to metal bond. *J Dent Res* 1978;**57** A:292, Abstr No.870.
89. Sced IR, McLean JW. The strength of metal/ceramic bonds with base metals containing chromium. *Brit Dent J* 1972;**132**:232-234.
90. Wight TA, Baumann JC, Pelleu GB. Variables affecting the strength of the porcelain/non-precious bond. *J Dent Res* 1976;**55**:608, Abstr. No. 675.
91. ISO TR 11405. Dental materials guidance on testing of adhesion to tooth structure. Technical report, 1994(E).
92. Versluis A, Tantbirojn D, Douglas WH. Why do shear bond tests pull out dentin? *J Dent Res* 1997;**76(6)**:1298-1307.

93. Stanley HR. Guest Editorial: An urgent plea for a standardized bonding (Adhesion) test. *J Dent Res* 1993;**72**:1362-1363.
94. De Munck J, Van Landuyt K, Peumans M, Poitevin A, Lambrechts P, Braem M, Van Meerbeek B. A critical review of the durability of adhesion to tooth tissue: Methods and results. *J Dent Res* 2005;**84(2)**:118-132.
95. LeLoup G, D'Hoore W, Bouter D, Degrange M, Vreven J. Meta-analytical review of factors involved in dentin adherence. *J Dent Res* 2001;**80(7)**:1605-1614.
96. Ogata M, Harada, N, Yamaguchi S, Nakajima M, Tagami J. Effect of self-etching primer vs phosphoric acid etchant on enamel to bur-prepared dentin. *Oper Dent* 2002;**27**:447-454.
97. Ernsta CP, Kotter T, Victor A, Canbek K, Brandenbusch M, Willershausen B. Marginal integrity of self- and total-etching adhesives in two different application protocols. *J Adhes Dent* 2004;**6(1)**:25-32.
98. Koliniotou-Koumpia E, Dionysopoulos P, Koumpia E. *In vivo* evaluation of microleakage from composites with new dentine adhesives. *J Oral Rehab* 2004;**31**:1014-1022.
99. Jensen ME, Chan DCN. Polymerization Shrinkage and Microleakage. In: Vanherle G, Smith DC, editors. *Proceedings of the International Symposium on Posterior Composite Resin Dental Restorative Materials*: 1982 October 13-14, Chapel Hill, NC. Netherlands: Peter Szule Publishing Co. 1985;243-262.
100. Ehrenberg D, Weiner GI, Weiner S. Long-term effects of storage and thermal cycling on the marginal adaptation of provisional resin crowns: A pilot study. *J Prosthet Dent* 2006;**95(3)**:230-236.
101. Ernst C, Galler P, Willershausen B, Haller B. Marginal integrity of class V Restorations: SEM versus dye penetration. *Dent Mater* 2008;**24**:319-327.

102. Ernst C, Cortain G, Spohn M, Rippin G, Willershausen B. Marginal integrity of different resin based composites for posterior teeth: an in vitro dye-penetration study on eight resin-composite and compomer-/adhesive combinations with a particular look at the additional use of flow-composites. *Dent Mater* 2002;**18**:351-358.
103. Frankenberger R, Lohbauer U, Schaible RB, Nikolaenko SA, Naumann M. Luting of ceramic inlays in vitro: Marginal quality of self-etch and etch-and-rinse adhesives versus self-etch cements. *Dent Mater* 2008;**24**:185-191.
104. Gladys S, van Meerbeek B, Lambrechts P, Vanherle G. Microleakage of adhesive restorative materials. *Am J Dent* 2001;**14(3)**:170-176.
105. Kubo S, Yokota H, Yokota H, Hayashi Y. Microleakage of cervical cavities restored with flowable composites. *Am J Dent* 2004;**17(1)**:34-37.
106. Kubo S, Yokota H, Yokota H, Hayashi Y. Effect of low viscosity resin-based composite on the microleakage of cervical restorations. *Am J Dent* 2003;**16(4)**:243-248.
107. Kubo s, Yokota H, Sata Y, Hayashi Y. Microleakage of self-etching primers after thermal and flexural load cycling. *Am J Dent* 2001;**14(3)**:163-169.
108. Moll K, Fritzenschaft A, Haller B. In vitro comparison of dentin bond systems: Effect of testing method and operator. *Dent Mater* 2004;**35(10)**:845-852.
109. Santini A, Plasschaert AJM, Mitchell S. Effect of composite resin placement techniques on the microleakage of two self-etching dentin-bonding agents. *Am J Dent* 2001;**14(3)**:133-136.
110. Frankenberger R, Tay FR. Self-etch vs etch-and-rinse adhesives: effect of thermo-mechanical loading on marginal quality of bonded resin composite restorations. *Dent Mater* 2005;**21**:397-412.

111. Nikaido T, Kunzelman K-H, Chen H, Ogata M, Harada N, Yamaguchi S, Cox CF, Hickel R, Tagami J. Evaluation of thermal cycling and mechanical loading on bond strength of a self-etching primer system to dentin. *Dent Mater* 2002;**18**:269-275.
112. Kubo S, Yokota H, Sata Y, Hayashi Y. The effect of flexural load cycling on the microleakage of cervical resin composites. *Oper Dent* 2001;**26**:451-459.
113. Kurogawa R, Finger WJ, Hoffman M, Endo T, Kanehira M, Komatsu M, Manabe A. Interactions of self-etching adhesives with resin composites. *J Dent* 2007;**35**:923-929.
114. Trajtenberg CP, Caram SJ, Kiat-amnuay S. Microleakage of all-ceramic crowns using self-etching resin luting agents. *Oper Dent* 2008;**33**(4):392-399.
115. Giachetti L, Russo DS, Bambi C. Influence of operator skill on microleakage of total-etch and self-etch bonding systems. *J Dent* 2008;**26**:49-53.
116. De Andrade OS, de Goes MF, Montes MAJR. Marginal adaptation and microtensile bond strength of composite indirect restorations bonded to dentin treated with adhesive and low-viscosity composite. *Dent Mater* 2007;**23**:279-287.
117. Kubo S, Yokota H, Yokota H, Hayashi Y. The effect of light-curing modes on the microleakage of cervical resin composite restorations. *J Dent* 2004;**32**:247-254.
118. Piemjai M, Watanabe A, Iwasaki Y, Nakabayashi N. Effect of remaining demineralised dentine on dental microleakage accessed by a dye penetration: how to inhibit microleakage? *J Dent* 2004;**32**:495-501.
119. Sadek FT, Moura SK, Ballester RY, Muench A, Cardoso PEC. The effect of long-term storage on the microleakage of composite resin restorations – qualitative and quantitative evaluation. *Pesqui Odontol Bras* 2003;**17**(3):261-266.

120. Corona SAM, Borsatto MC, Palma Dibb RG, Ramos RP, Brugnera A Jr, Pécora JD. Microleakage of class V resin composite restorations after bur, air-abrasion or Er:Yag laser preparation. *Oper Dent* 2001;**26**:491-497.
121. Pradelle-Plasse N, Nechad S, Tavernier B, Colon P. Effect of dentin adhesives on the enamel-dentin/composite interfacial microleakage. *Am J Dent* 2001;**14(6)**:2001.
122. Rossomondo KJ, Wendt SL Jr. Thermocycling and dwell times in microleakage evaluation for bonded restorations. *Dent Mater* 1995;**11**:47-51.
123. Iwami Y, Hayashi M, Takeshige F, Ebisu S. The accuracy of electrical method for microleakage evaluation by a three-dimensional analysis. *J Dent* 2007;**35**:268-274.
124. Pradelle-Plasse N, Wenger F, Picard B, Colon P. Evaluation of microleakage of composite resin restorations by an electrochemical technique: the impedance methodology. *Dent Mater* 2004;**20**:425-434.
125. Iwami Y, Yamamoto H, Ebisu S. A new electrical method for detecting marginal leakage of in vitro resin restorations. *J Dent* 2000;**28**:241-247.
126. Göhring TN, Zehnder M, Sener B, Schmidlin PR. In vitro microleakage of adhesive-sealed dentin with lactic acid and saliva exposure: a radio-isotope analysis. *J Dent* 2004;**32**:235-240.
127. Going RE. Microleakage around dental restorations: a summarizing review. *J Am Dent Assoc* 1972;**84(6)**:1349-1357.
128. Kidd EA. Microleakage in relation to amalgam and composite restorations. A laboratory study. *Br Dent J* 1976;**141(10)**:305-310.

129. Hevinga MA, Opdam NJM, Frencken JE, Bronkhorst EM, Truin GJ.
Microleakage and sealant penetration in contaminated carious fissures.
J Dent 2007;**35**:909-914.
130. D'Alpino PH, Pereira JC, Rueggeberg FA, Svizero NR, Miyake K, Pashley DH.
Efficacy of composite surface sealers in sealing cavosurface marginal gaps.
J Dent 2006;**34**:252-259.
131. Duquia RCS, Osinaga PWR, Demarco FF, Habekost LV, Conceição EN. Cervical microleakage in MOD restorations: In vitro comparison of indirect and direct composite. *Oper Dent* 2006;**31(6)**:682-287.
132. Delme KIM, Deman PJ, De Moor RJG. Microleakage of class V resin composite restorations after conventional and Er:YAG laser preparation.
J Oral Rehab 2005;**32**:676-685.
133. Cenci M, Demarco F. Class II composite resin restorations with two polymerization techniques: relationship between microtensile bond strength and marginal leakage. *J Dent* 2005;**33**:603-610.
134. Tobias RS, Rippin JW, Browne RM, Wilson CA. A further study of the antibacterial properties of dental restorative materials.
Int Endod J 1988;**21**:381-392.
135. Yap AUJ, Khor E, Foo SH. Fluoride release and antibacterial properties of new-generation tooth-colored restoratives. *Oper Dent* 1999; **24**:197-305.
136. Beyth N, Domb AJ, Weiss EI. An *in vitro* quantitative antibacterial analysis of amalgam and composite resins. *J Dent* 2007;**35**:201-206.
137. Morrier JJ, Suchett-Kaye G, Nguyen D, Rocca JP, Blanc-Benon J, Barsotti O.
Antimicrobial activity of amalgams, alloys and their elements and phases.
Dent Mater 1998;**14**:150-157.

- 138.Sanders BJ, Gregory RL, Moore K, Avery DR. Antibacterial and physical properties of resin modified glass-ionomers combined with chlorhexidine. *J Oral Rehab* 2002;**29**:553-558.
- 139.Boeckh C, Schumacher E, Podbielski A, Haller B. Antibacterial activity of restorative dental biomaterials in vitro. *Caries Res* 2002;**36**:101-107.
- 140.Karanika-Kouma A, Dionysopoulos P, Koliniotou-Koubia. Antibacterial properties of dentin bonding systems, polyacid-modified resins and composite resins. *J Oral Rehab* 2001;**28**:157-160.
- 141.Kozai K, Suzuki J, Okada M, Nagasaka N. In vitro study of antibacterial and antiadhesive activities of fluoride-containing light-cured fissure sealants and a glass ionomer liner/base against oral bacteria. *J Dent Child* 2000;**March-April**:117-122.
- 142.Palenik CJ, Behnen MJ, Setcos JC, Miller CH. Inhibition of microbial adherence and growth by various glass ionomers in vitro. *Dent Mater* 1992;**8**:16-20.
- 143.Scherer W, Lippman N, Kaim J. Antimicrobial properties of glass-ionomer cements and other restorative materials. *Oper Dent* 1989;**14**:77-81.
- 144.Tobias RS. Antibacterial properties of dental restorative materials: a review. *Int Endod J* 1988;**21**:155-160.
- 145.Lewinstein I, Matalon S, Slutzkey S, Weiss EI. Antibacterial properties of aged dental cements evaluated by direct-contact and agar diffusion tests. *J Prosthet Dent* 2005;**93**:364-371.
- 146.Özer F, Karakaya Ş, Ünlü, Erganiş O, Kav K, Imazato S. Comparison of antibacterial activity of two dentin bonding systems using agar well technique and tooth cavity model. *J Dent* 2003;**31**:111-116.

147. Steward CD, Stocker SA, Swenson JM, O'Hara CM, Edwards JR, Gaynes RP, McGowan JE, Tenover FC. Comparison of agar dilution, disk diffusion, microscan, and vitek antimicrobial susceptibility testing methods to broth microdilution for detection of fluoroquinolone-resistant isolates of the family Enterobacteriaceae. *J Clin Microbiol* 1999;**37**(3):544-547.
148. Meryon SD, Johnson SG. The modified model cavity method for assessing Antibacterial properties of dental restorative materials. *J Dent Res* 1989;**68**(5):835-839.
149. Bimstein E, Ram D, Irshied J, Naor R, Seal MN. Periodontal diseases, caries, and microbial composition of the subgingival plaque in children: a longitudinal study. *ASDC J Dent Child* 2002;**69**(2):123,133-137.
150. Kuramoto A, Imazato S, Walls AWG, Ebisu S. Inhibition of root caries progression by an antibacterial adhesive. *J Dent Res* 2005;**84**(1):89-93.
151. Caufield PW, Dasanayake AP, Li Y. The antimicrobial approach to caries management. *J Dent Educ* 2001;**65**(1):1091-1095.
152. Tanagawa MT, Yoshida K, Matsumoto S, Yamada T, Atsuta M. Inhibitory effect of antibacterial resin composite against *Streptococcus mutans*. *Caries Res* 1999;**33**:366-371.
153. Bapna MS, Murphy R, Mukherjee S. Inhibition of bacterial colonization by antimicrobial agents incorporated into dental resins. *J Oral Rehab* 1988;**15**:405-411.

154. Tenover FC, Swenson JM, O'Hara CM, Stocker SA. Ability of commercial and reference antimicrobial susceptibility testing methods to detect Vancomycin resistance in Enterococci. *J Clin Microbiol* 1995;**33(6)**:1524-1527.
155. Emilson CG, Bergenholtz G. Antibacterial activity of dentinal bonding agents. *Quintessence Int* 1993;**14(7)**:511-515.
156. Going RE, Loesche WJ, Grainger DA, Syed SA. The viability of microorganisms in carious lesions five years after covering with a fissure sealant. *JADA* 1978;**97**:155-462.
157. Gondim JO, Duque C, Hebling J, Giro EMA. Influence of human dentine on the antibacterial activity of self-etching adhesive systems against cariogenic bacteria. *J Dent* 2008;**36**:241-248.
158. Çehreli ZC, Atac AS, Sener B. Antimicrobial properties of self-etching primer-bonding systems. *Oper Dent* 2003;**28(2)**:143-148.
159. Decker E-M, Weiger R, Wiech I, Heide P-E, Brex M. Comparison of antiadhesive and antibacterial effects of antiseptics on *Streptococcus sanguinis*. *Eur J Oral Sci* 2003;**111**:144-148.
160. Pappas M, Burns DR, Moon PC, Coffey JP. Influence of a 3-step tooth disinfection procedure on dentin bond strength. *J Pros Dent* 2005;**93(6)**:545-550.
161. Schmalz G, Ergücü Z, Hiller K-A. Effect of dentin on the antibacterial activity of dentin bonding agents. *J Endod* 2004;**30(5)**:352-358.

- 162.Owens BM, Lim DY, Arheart KL. The effect of antimicrobial pre-treatments on the performance of resin composite restorations. *Oper Dent* 2003;**28**(6):716-722.
- 163.Imazato S, Kuramoto A, Kaneko T, Shigeyuki E, Russel RRB. Comparison of antibacterial activity of simplified adhesive systems.
Am J Dent 2002;**15**(6):356-360.
- 164.Garcia MB,Nör JE, Schneider LG, Bretz WA. A model for clinical evaluation of the effect of antimicrobial agents on carious dentin.
Am J Dent 2001;**14**(3):120-122.
- 165.Imazato S, Torii M, Tsuchitani Y, McCabe JF, RRB Russel. Incorporation of bacterial inhibitor into resin composite. *J Dent Res* 1994;**73**(8):1437-1443.
- 166.Jedrychowski JR, Caputo AA, Kerper S. Antibacterial and mechanical properties of restorative materials combined with chlorhexidines.
J Oral Rehab 1983;**10**:373-381.
- 167.Imazato S, Kuramoto A, Takahashi Y, Ebisu S, Peters MC. In vitro antibacterial effects of the dentin primer of Clearfil Protect Bond.
Dent Mater 2006;**22**:527-532.
- 168.Imazato S, Kinomoto Y, Tarumi H, Ebisu S, Tay FR. Antibacterial activity and bonding characteristics of an adhesive resin containing antibacterial monomer MDPB. *Dent Mater* 2003;**19**:313-319.

- 169.Imazato S, Torii Y, Takatsuka T, Inoue K, Ebi N, Ebisu S. Bactericidal effect of dentin primer containing antibacterial monomer methacryloyloxydodecylpyridinium bromide (MDPB) against bacteria in human carious dentin. *J Oral Rehab* 2001;**28**:314-319.
- 170.Imazato S, Ehara A, Torii M, Ebisu S. Antibacterial activity of dentine primer containing MDPB after curing. *J Dent* 1998;**26(3)**:267-271.
- 171.Burger KM, Cooley RL, Garcia-Godoy F. Effect of thermocycling times on dentin bond strength. *J Esthet Dent* 1992;**4(6)**:197-198.
- 172.Koch AL. Growth Measurement. In: Gerhardt P, Murray RGE, Costilow RN, Nester EW, Wood WA, Krieg NR, Phillips GB, eds. *Manual of Methods for General Bacteriology*, 2nd Printing. Washington: American Society for Microbiology 1981;179-207.
- 173.Kirby WMM, Bauer AW, Sherris JC, Turck M. Antibiotic susceptibility testing by a standardized single disc method. *Am J Clin Path* 1966;**45**,493-496.
- 174.Hillman JD. Genetically modified Streptococcus mutans for the prevention of dental caries. *Antonie Van Leeuwenhoek* 2002;**82(1-4)**:361-366.
- 175.Brandt PD, de Wet FA, Botha SJ, de Wet BJ. Anti-bacterial efficacy of a new self-etching dentine bonding agent. *SADJ* 2004;**59(7)**:280-282.
- 176.Bui H, Le MA, Shellard E, Ng D. Bond strength studies of self-etch adhesive systems. *J Dent Res* 2002;**81**:A160.
- 177.Torres CP, Corona SA, Ramos RP, Palma-Dibb RG, Borsatto MC. Bond strength of self-etching primer and total-etch adhesive systems to primary dentin. *J Dent Child (Chic)* 2004;**71(2)**:131-134.

178. Göhring TN, Zehnder M, Sener B, Schmidlin PR. In vitro microleakage of adhesive-sealed dentin with lactic acid and saliva exposure: a radio-isotope analysis. *J Dent* 2004;**32**:235-240.
179. Grégoire G, Guignes P, Millas A. Effect of self-etching adhesives on dentin permeability in a fluid flow model. *J Prosthet Dent* 2005;**93**(1):56-63.
180. Ceballos L, Camejo DG, Fuentes MV, Osorio R, Toledano M, Carvalho RM, Pashley DH. Microtensile bond strength of total-etch and self-etching adhesives to caries-affected dentine. *J Dent* 2003;**31**:469-477.
181. Arrais CAG, Giannini M, Nakajima M, Tagami J. Effects of additional and extended acid etching on bonding to caries-affected dentine. *Eur J Oral Sci* 2004;**112**:458-464.
182. Agostini FG, Kaaden C, Powers JM. Bond strength of self-etching primers to enamel and dentin of primary teeth. *Pediatr Dent* 2001;**23**(6):481-486.
183. Courson F, Bouter D, Ruse ND, Degrange M. Bond strengths of nine current dentine adhesive systems to primary and permanent teeth. *J Oral Rehab* 2005;**32**:296-303.
184. Bonilla ED, Stevenson RG, Yashar M, Caputo AA. Effect of application technique and dentin bonding agent interaction on shear bond strength. *Oper Dent* 2003;**28**(5):568-573.
185. Sardella TN, De Castro FLA, Sanabe ME, Hebling J. Shortening of primary dentin etching time and its implication on bond strength. *J Dent* 2005;**33**:355-362.
186. Alexandre RS, Sundfeld RH, Giannini M, Lovadino JR. The influence of temperature of three adhesive systems on bonding to ground enamel. *Oper Dent* 2008;**33**(3):272-281.

187. Duarte S, Botta AC, Meire M, Sadan A. Microtensile bond strengths and scanning electron microscopic evaluation of self-adhesive and self-etch resin cements to intact and etched enamel. *J Prosthet Dent* 2008;**100(3)**:203-210.
188. Watanabe T, Tsubota K, Takamizawa T, Kurokawa H, Rikuta A, Ando S, Miyazaki M. Effect of prior acid etching on bonding durability of single-step adhesives. *Oper Dent* 2008;**33(4)**:426-433.
189. Chuang S, Chang L, Chang C, Yaman P, Liu J. Influence of enamel wetness on composite restorations using various dentine bonding agents: Part II – effects on shear bond strength. *J Dent* 2006;**34**:352-361.
190. Van Landuyt KL, Kanumilli P, De Munck J, Peumans M, Lambrechts P, Van Meerbeek B. Bond strength of a mild self-etch adhesive with and without prior acid-etching. *J Dent* 2006;**34**:77-85.
191. Van Meerbeek B, Kanumilli P, De Munck J, Van Landuyt K, Lambrechts P, Peumans M. A randomized controlled study evaluating the effectiveness of a two-step self-etch adhesive with and without selective phosphoric-acid etching of enamel. *Dent Mater* 2005;**21**:375-383.
192. Inoue S, Vargas MA, Abe Y, Yoshida Y, Lambrechts P, Vanherle G, Sano H, Van Meerbeek B. Microtensile bond strength of eleven contemporary adhesives to enamel. *Am J Dent* 2003;**16(5)**:329-334.
193. Miyazaki M, Hinoura K, Honjo G, Onose H. Effect of self-etching primer application method on enamel bond strength. *Am J Dent* 2002;**15(6)**:412-416.
194. Miyazaki M, Hirohata N, Takagaki K, Onose H, Moore BK. Influence of self-etching primer drying time on enamel bond strength of resin composites. *J Dent* 1999;**27**:203-207.

- 195.Pashley DH, Tay FR. Aggressiveness of contemporary self-etching adhesives
Part II: Etching effects on unground enamel. *Dent Mater* 2001;**17**(5):430-444.
- 196.Sundfeld RH, Valentino TA, de Alexandre RS, Briso ALF, Sundefeld MLMM.
Hybrid layer thickness and resin tag length of a self-etching adhesive bonded to
sound dentin. *J Dent* 2005;**33**:675-681.
- 197.Leirskar J, Oilo G, Nordbo H. In vitro shear bond strength of two resin
composites to dentin with five different dentin adhesives.
Quintessence Int 1998; **29**(12):787-792.
- 198.Miranda C, Prates LH, Vieira Rde S, Calvo MC. Shear bond strength of different
adhesive systems to primary dentin and enamel
J Clin Pediatr Dent 2006;**31**(1):35-40.
- 199.Kaaden C, Powers JM, Friedl KH, Schmalz G. Bond strength of self-
etching adhesives to dental hard tissues.
Clin Oral Investig 2002;**6**(3):155-160.
- 200.Bonilla ED, Stevenson RG, Yashar M, Caputo AA. Effect of application
technique and Dentin Bonding Agent Interaction on shear bond strength.
Oper Dent 2003;**28**(5):568-573.
- 201.Kiremitçi A, Yalçın F, Gokalp S. Bonding to enamel and dentin using self-
etching adhesive systems. *Quintessence Int* 2004; **35**(5):367-370.
- 202.Proença JP, Polido M, Osorio E, Carolina M, Erhardt G, Aguilera FS, García-
Godoy F, Osorio R, Toledano M. Dentin regional bond strength of self-etch and
total-etch adhesive systems. *Dent Mater* 2007;**23**:1542-1548.
- 203.Carhillo MRO, Carvalho RM, Tay FR, Pashley DH. Effects of storage media on
mechanical properties of adhesive systems. *Am J Dent* 2004;**17**:104-108.

- 204.Santerre JP, Shajil L, Leung BW. Relation of dental composite formulations to their degradation and the release of hydrolyzed polymeric-resin-derived products. *Crit Rev Oral Biol Med* 2001;**12**:136-151.
- 205.Sengün A, Ünlü N, Özer F, Öztürk B. Bond strength of five current adhesives to caries-affected dentin. *J Oral Rehab* 2002;**29**:777-781.
- 206.Yoshiyama M, Tay FR, Doi J, Nishitani Y, Yamada T, Ito K, Carvalho RM, Nakajima M, Pashley DH. Bonding of self-etching and total-etch adhesives to carious dentin. *J Dent Res* 2002;**81(8)**:556-560.
- 207.Bekes K, Boeckler L, Gernhardt CR, Schaller H-G. Clinical performance of a self-etching and a total-etch adhesive system – 2-year results. *J Oral Rehab* 2007;**34**:855-886.
- 208.Breschi L, Mazzoni A, Ruggeri A, Cadenaro M, Di Lenarda R, De Stefano Dorigo E. Dental adhesion review: Aging and stability of the bonded interface. *Dent Mater* 2008;**24**:90-101.
- 209.Donmez N, Beli S, Pashley DH, Tay FR. Ultrastructural correlates of in vivo/in vitro bond degradation in self-etch adhesives. *J Dent Res* 2005;**84(4)**:355-359.
- 210.van Dijken JWV, Pallesen U. Long-term retention of etch-and-rinse and self-etch adhesives and a resin-modified glass ionomer cement in non-cariou cervical lesions. *Dent Mater* 2008;**24**:915-922.
- 211.Abdalla AI, Feilzer AJ. Four-year water degradation of a total-etch and two self-etching adhesives bonded to dentin. *J Dent* 2008;**36**:611-617.
- 212.Reis AF, Giannini M, Pereira PNR. Long-term TEM analysis of the nanoleakage patterns in resin-dentin interfaces produced by different bonding strategies. *Dent Mater* 2007;**23**:1164-1172.

213. Tay FR, Pashley DH, Peters MC. Adhesive permeability affects composite coupling to dentin treated with a self-etch adhesive.
Oper Dent 2003;**28(5)**:610-621.
214. Li HP, Burrow MF, Tyas MJ. The effect of long-term storage on nanoleakage.
Oper Dent 2001;**26**:609-616.
215. Fabianelli A, Kugel G, Ferrari M. Efficacy of self-etching primer on sealing margins of class II restorations. *Am J Dent* 2003;**16(1)**:37-41.
216. Li H, Burrow MF, Tyas MJ. The effect of load cycling on the nanoleakage of dentin bonding systems. *Dent Mater* 2002;**18**:111-119.
217. Eminkahyagil N, Gokalp S, Korkmaz Y, Baseren M, Karabulut E. Sealant and composite bond strength to enamel with antibacterial/self-etching adhesives.
Int J Paed Dent 2005;**15**:274-281.
218. Toledano M, Perdigão J, Osorio R, Osorio E. Effect of dentin deproteinization on microleakage of class V composite restorations. *Oper Dent* 2000;**25**:497-504.
219. De Munck J, Van Landuyt K, Coutinho E, Poitevin A, Peumans M, Lambrechts P, Van Meerbeek B. Micro-tensile bond strength of adhesives bonded to class-I cavity-bottom dentin after thermo-cycling. *Dent Mater* 2005;**21**:999-1007.
220. Bortolotto T, Onisor I, Krejci I, Ferrari M. Effect of cyclic loading under enzymatic activity on resin-dentin interfaces of two self-etching adhesives.
Dent Mater 2008;**24**:178-184.
221. Ferrari M, Mason PN, Vichi A. Role of hybridization on marginal leakage and bond strength. *Am J Dent* 2000;**13(6)**:229-336.
222. Feilzer AJ, De Gee AJ, Davidson CL. Setting stress in composite resin in relation to configuration of the restoration.
J Dent Res 1987;**66(11)**:1636-1639.

223. Alster D, Feilzer AJ, de Gee AJ, Davidson CL. Polymerization contraction stress in thin resin composite layers as a function of layer thickness. *Dent Mater* 1997;**13(3)**:146-150.
224. Yoshiyama M, Carvalho R, Sano H, Horner J, Brewer PD, Pashley DH. Interfacial morphology and strength of bonds made to superficial versus deep dentin. *Am J Dent* 2003;**8**:297-302.
224. Yap AUJ, Sau CW, Lye KW. Effects of finishing/polishing time on surface characteristics of tooth-coloured restoratives. *J Oral Rehabil.* 1998;**25**:456-61.
225. Santini A, Mitchell S. Effect of wet and dry bonding techniques on marginal leakage. *Am J Dent* 1998;**11(5)**:219-224.
226. Santini A, Mitchell S. Microleakage of composite restorations bonded with three new dentin bonding agents. *J Esthet Dent* 1998;**10(6)**:296-304.
227. Santini A. Microleakage of resin-based composite restorations using different solvent-based bonding agents and methods of drying acid-etched dentin. *Am J Dent* 1999;**12(4)**:194-200.
228. Fortin D, Swift EJ, Denehy GE, Reinhardt JW. Bond strength and microleakage of current dentin adhesives. *Dent Mater* 1994;**10(4)**:253-258.
229. Saunders WP, Saunders EM. Microleakage of bonding agents with wet and dry bonding techniques. *Am J Dent* 1996;**9(1)**:34-36.
230. Beznos C. Microleakage at the cervical margin of composite Class II cavities with different restorative techniques. *Oper Dent* 2001;**26(1)**:60-69.
231. Mjör IA. The reasons for replacement and the age of failed restorations in general dental practice. *Acta Odontol Scand* 1997;**55(1)**:58-63.
232. Imazato S. Antibacterial properties of resin composites and dentin bonding systems. *Dent Mater* 2003;**19**:449-457.

233. Atac AS, Çehreli ZC, Sener B. Antibacterial Activity of Fifth-Generation Dentin Bonding Systems. *J Endodont* 2001;**27(12)**:730-733.
234. Prati C, Fava F, Di Gioia D, Selighini M, Pashley DH. Antibacterial effectiveness of dentin bonding systems. *Dent Mater* 1993;**9**:338-343.
235. Christensen GJ. Self-etching primers are here. *J Am Dent Assoc* 2001;**132(7)**:1041-1043.
236. Hoos JC. Clinical findings using a self-etching primer. *Dent Today* 1999;**18(9)**:102-103.
237. Holmgren CJ, Pilot T. Preliminary research agenda for minimal intervention techniques for caries. *J Public Health Dent* 1996; **56(3 Spec No)**:164-165.
238. Kleinberg I. A mixed-bacteria ecological approach to understanding the role of the oral bacteria in dental caries causation: an alternative to streptococcus mutans and the specific-plaque hypothesis. *Crit Rev Oral Biol Med* 2002;**13(2)**:108-125.
239. Murray PE, Hafez AA, Smith AJ, Cox CF. Bacterial microleakage and pulp inflammation associated with various restorative materials. *Dent Mater* 2002;**18(6)**:470-478.
240. Palenik CJ, Setcos JC. Antimicrobial abilities of various dentine bonding agents and restorative materials. *J Dent* 1996;**24(4)**:289-295.
241. Fraga RC, Siqueira JF (Junior), de Uzeda M. In vitro evaluation of antibacterial effects of photo-cured glass ionomer liners and dentin bonding agents during setting. *J Prosthet Dent* 1996;**76(5)**:483-486.
242. Breschi L, Gobbi P, Falconi M, Mazzotti G, Prati C, Perdigão J. Ultra-morphology of self-etching adhesives on ground enamel: A high resolution SEM study. *Am J Dent* 2003;**16 Spec Issue**:57A-62A.

243. Goracci C, Bertelli E, Ferrari M. Bonding to worn or fractured incisal edges:

Shear bond strength of new adhesive systems. *Quintessence Int* 2004;**35**:21-27.

244. Hashimoto M, Ohno H, Yoshida E, Hori M, Sano H, Kaga M, Oguchi H. Resin-enamel bonds made with self-etching primers on ground enamel.

Eur J Oral Sci 2003;**111**:447-453.

8. List of Tables

- Table I: Specimen preparation variables in 50 studies of dentine bond strength
- Table II: Testing variables in 50 studies of dentine bond strength
- Table III: Analysis of the 50 studies
- Table IV: Criteria for scoring microleakage
- Table V: Dentine shear bond strength values
- Table VI: Microleakage evaluation at the incisal ENAMEL margins
- Table VII: Microleakage evaluation at the apical DENTINE margins
- Table VIII: Mean inhibition zones (mm) for the primers of the three different bonding systems tested against the three test organisms
- Table VIX: Statistical comparison (Student-t test) of primers to indicate significant differences ($p < 0.05$) in the anti-bacterial inhibition of *S. mutans* (S.m), *L. paracasei* (L.p) and *A. naeslundii* (A.n)
- Table X: Enamel and dentine leakage scores compared to dentine shear bond strength evaluation

9. List of Figures

Fig. 1: Bonding agent classification according to type of etching technique used

Fig. 2: Bonding agent penetration into etched dentine

Fig. 3: SEM shows long resin tags projecting into the dental tubules

Fig. 4: Resin infiltration into tubules and demineralised dentine

Fig. 5: SEM photograph showing the hybrid layer and adhesive layer

Fig. 6: Smear layer demineralization according to acidity

Fig. 7: Evolution of bonding agents

Fig. 8: Schematic drawing of the patented bonding jig used for ISO TR 11405

Fig. 9: Schematic drawing of the assembled bonding jig

Fig. 10: Patented, notched shear head

Fig. 11: Schematic drawing of a shear test using a blunt knife-etch shear head

Fig. 12: Example of shear bond research results

Fig. 13: SEM photograph of the adhesive interface with shrinkage related gaps

Fig. 14: Example of a microleakage course presented by the Ankara University

Fig. 15: Grounding technique to produce flat/level dentine surfaces

Fig. 16: Mounted tooth with resin stub

Fig. 17: Ultradent bonding jig

Fig. 18: Ultradent ring clamp for Instron test

Fig. 19: Shear-head attachment for Instron testing machine

Fig. 20: Cerana Bur kit from the Cerana Inlay System (Nordiska Dental)

Fig. 21: Prepared cavity at the cemento-enamel junction

Fig. 22: Resin embedded tooth with restored cavity after basic Fuchsin treatment

Fig. 23: Re-imbedded tooth. Ready for longitudinal sectioning

Fig. 24: Sectioned tooth. Ready for microleakage evaluation

Fig. 25: Cavity indicating microleakage scoring criteria

Fig. 26: *S.mutans* inhibition by ABF primer

10. Materials and Equipment Manufacturers

Manufacturer : 3M ESPE, St Paul, Minnesota, USA

Products:

Adper Scotchbond Multipurpose Plus^a

Scotchbond Multipurpose Plus^a

Note: Both products are the same. The company added 'Adper' to all their bonding agents three years ago.

Prompt-L-Pop^w

Adper Prompt-L-Pop^f

Note: Both products are the same but modifications have been made to the original version. The company added 'Adper' to all their bonding agents five years ago.

Z100 Shade A1 compositeⁱ

Sof-Lex polishing disks^s

Manufacturer: Kuraray, Osaka, Japan

Products:

Clearfil ABF^b

Clearfil Protect Bond^b

Note: Both ABF and Clearfil Protect Bond are the same products – ABF is the experimental version of Clearfil Protect Bond.

Clearfil SE Bond^c

Manufacturer: Dentsply, Konstanz, Germany

Products:

Xeno III^d

Enhance polishing system^t

Manufacturer: Kerr Corporation, Orange, California, USA

Products:

Optibond Solo Self-etch^e

Optibond Solo Plus Self-etch^p

Manufacturer: VJCHEM, Doncaster, Canada

Product: Thymol^g (0.1%)

Manufacturer: Imptech, Sunward Park, South Africa

Product: Imptech polishing machine^h (Fig. 15)

Manufacturer: Ultradent Products, Salt Lake City, Utah, USA

Products:

Ultradent bonding jig^j (Fig. 17)

Ultradent ring clamp^l for Instron test (Fig. 18)

Shear-head attachment^m for Instron testing machine (Fig. 19)

Manufacturer: Kerr Corporation, Romola, Michigan, USA

Product: Optolux 501 Curing light^k

Manufacturer: Instron Corporation, Canton, Michigan, USA

Product: Instron Universal Testing machineⁿ

Manufacturer: Nordiska Dental, Ängelholm, Sweden

Product: Cerana Bur kit from the Cerana Inlay System^o: (Fig. 20)

Manufacturer: Coltène Whaledent, Altstätten, Swizerland

Product: One CoatSE Bond^q

Manufacturer: Hareaus Kulzer, Hanau, Germany

Product: iBond^f

Manufacturer: Sigma-Aldric, St Louis, Missouri, USA

Product: Fuchsin^u

Manufacturer: Struers, Ballerup, Denmark

Product: Struers Accutom-2 low speed cutting machine^y

11. Acknowledgements

A word of thanks to Dr Francien Botha, Centre for Stomatological Research, School of Dentistry, University of Pretoria for her help and advice with the anti-bacterial study. Also a word of thanks to Prof IC du Preez, Head of the Department of Operative Dentistry, Dental School, Medunsa campus of the University of Limpopo for allowing me to use his Department's laboratory facilities, Instron testing machine and thermocycling equipment for the shear bond strength and microleakage studies.

A special word of thanks to my promoter Prof FA De Wet, Head of the Department of Odontology for all his help, patience (over many years), guidance and proof reading. It is much appreciated.