



CONSIDERATIONS FOR STOPE GULLY STABILITY IN GOLD AND PLATINUM MINES IN SOUTH AFRICA

By

Kumendrie Naidoo

Submitted in fulfilment of the requirements for the degree of Master of Science in the
Faculty of Engineering.

University of Pretoria

Study Supervisor: Professor. Matthew F Handley

April 2001



UNIVERSITEIT VAN PRETORIA
UNIVERSITY OF PRETORIA
YUNIBESITHI YA PRETORIA

To my very special angel - for all his love and support



“What privilege it is for a geologist to live and wrestle for months and years with a tough problem, watching it forced by the steady penetration of underground workings, to yield and at last surrender, so that its inner secrets may be known.”

L.C.Graton

ABSTRACT

Gullies have been regarded as the “artery” in mining because they provide the only access route for material, people and ore in stopes. It thus becomes vital to provide the industry with suitable guidelines for gully layouts, geometry and the support required at all depths to keep the gully safe at all times.

The research has indicated that best practices for gully layouts have been well recognised, but often poorly applied for many years. To address the issue of best gully practices, research was based on a review of past practices, underground visits, mine standards, codes of practice and the use of numerical modelling as a tool to back- analyse the underground conditions observed.

The recommendations provided do not attempt to develop any new techniques for gully protection. They try to provide a guide for best practice under various geotechnical conditions. Based on depth, or stress environment, a broad based recommendation for gully geometry is provided. Using numerical modelling calibrated to underground observations, optimum widths and spans for each mining layout used at different depths are provided as a prescriptive guideline.

Some of the conclusions include the following:

- Sidings can only be omitted where stress damage does not occur.
- A minimum siding width of 2m is recommended wherever sidings are cut.
- Lagging sidings should be avoided and used only if absolutely essential.
- In high stress areas gullies should be footwall lifted behind the stope faces or within wide headings.
- All sidings must be cut on reef. Off reef sidings are not acceptable.
- Correct blasting practice is essential to ensure stability of gully shoulders.
- Gully width and span between support over gullies should be minimised.
- Gullies must be kept straight.

Excavation and cleaning of downdip sidings remains problematical from a practical mining point of view and future research is recommended in this area.

Acknowledgements:

I would like to thank my supervisor Professor Matthew Handley for his guidance and understanding during the study.

To the management committee of Simrac the author is grateful for their approval to use research carried out for project GAP 602 for this study.

For the exchange of ideas and general assistance, the author would like to thank Mr A.R. Leach.

For assistance in the collection of historical data and general input on the Bushveld mines, I am thankful to Dave Spencer.

Certain photographs of gullies on the Basal Reef are reproduced by courtesy of AngloGold rock engineering staff.

I am sincerely grateful to my mom, whose unfailing encouragement has motivated me throughout the study.

To my siblings Des and Navi and my family and friends who have supported me, I thank you.

CONTENTS

Acknowledgements	iii
List of Tables	viii
List of Figures	ix
Definitions	1
CHAPTER 1- INTRODUCTION	7
CHAPTER 2 LITERATURE REVIEW	10
2.1 Historical perspective - the who, what and when in stope gullies	11
2.2 Mining methods and associated gully conditions for various depths	17
2.2.1 Gully geometry options	17
2.2.2 Shallow depth	18
2.2.3 Intermediate depth	19
2.2.4 Deep level mining	20
2.3 Fracturing in gullies	22
2.3.1 General stress fracture pattern in a stoping environment	22
2.3.2 Stress fracture patterns due to gully geometries	25
2.3.3 Wide heading and footwall lifted gully	26
2.3.4 Mining with no gully heading	27
2.3.5 Mining with ASG gully leading the stope face	27
2.3.6 Mining with a wide advance heading and an Oblique underhand panel face	31
2.3.7 Overhand versus underhand layout	31
2.4 Factors influencing gully conditions	32
2.4.1 Gully geometry	34
2.4.2 Leads and lags	34
2.4.3 Face shape	35
2.4.4 Blasting	36
2.4.5 Depth of gully	36
2.4.6 Width of the gully	37
2.5 Geological considerations	38
2.5.1 Gold reef types	38
2.5.2 Platinum reef types	40

2.6	Support of stope gullies	42
2.6.1	Support objectives and design considerations	42
2.6.2	Support alongside gullies	44
2.6.3	Gully hangingwall and sidewall support	47
2.7	Generalised published guidelines for stope gullies	49
2.8	Safety in gullies	52
2.9	Conclusions drawn from published literature	55
CHAPTER 3	DATA GATHERING TO ASSESS CURRENT INDUSTRY PRACTICE	57
3.1	Introduction	57
3.2	Format of data gathered from mines	57
3.3	Summary of mining areas visited	59
3.4	Industry opinions on gully issues	60
3.4.1	Purpose of a gully	61
3.4.2	Key issues for maintenance of safe gullies	61
3.5	Gully layout and geometry issues	62
3.5.1	What are the preferred gully layouts?	62
3.5.2	What constitutes a siding?	63
3.5.3	Why should a siding be created?	63
3.5.4	Where should a siding be cut?	64
3.5.5	At what mining depth is a siding required?	65
3.5.6	Hangingwall profile and gully depth?	65
3.5.7	How big should a gully be?	65
3.5.8	What is a stable span across a gully?	67
3.5.9	What needs to be done to keep a gully straight?	67
3.5.10	What influence does panel lead have on gullies?	68
3.5.11	How big should a wide heading be?	68
3.5.12	How is gully serviceability maintained?	69
3.6	Gully support issues	69
3.6.1	What support is required in a gully?	69
3.7	Blasting practice	72
3.8	Other mining practice issues	72
3.9	Conclusions based on industry opinions	73
3.10	Planned industry gully practices	74
3.10.1	Gully geometries in use in industry	74
3.10.2	Application of gully types by mines	75

3.10.3	Summary of gully dimensions based on mine standards	79
3.11	Support strategies currently in use	86
3.11.1	Basic support	87
3.11.2	Additional support	90
3.11.3	Remedial support	91
CHAPTER 4	EVALUATION OF CURRENT PRACTICES BASED ON UNDERGROUND INSPECTIONS	93
4.1	Introduction	93
4.2	Rating of gully conditions	93
4.3	Mining practice compliance with mine standards	94
4.4	Summary of observed gully behaviour resulting from geometry, stress state and ground conditions	103
4.4.1	Shallow depth	103
4.4.2	High stress conditions	123
4.4.3	Effect of reef dip	140
4.4.4	Contribution of mining practices to gully conditions	141
4.4.5	Gully conditions as a function of depth and geometry	151
CHAPTER 5	NUMERICAL ANALYSIS OF GULLY GEOMETRIES	154
5.1	Numerical modelling methodology	154
5.1.1	The modelling process	154
5.1.2	Gully model objectives	156
5.1.3	Description of models	156
5.2	Shallow platinum cases – sidings and pillars	160
5.2.1	Geometries examined	160
5.2.2	Comparison of modelled platinum gully behaviour	162
5.3	Deeper cases – ASG's and footwall lifting	171
5.3.1	Geometries examined	171
5.3.2	Comparison of modelled gully behaviour	173
5.4	Three dimensional analyses of gully layouts	181
5.4.1	Description of three – dimensional model geometries	181
5.4.2	Single step FLAC3D models	183
5.4.3	Multi step FLAC3D models	197
5.5	Broad conclusions derived from numerical models	203



CHAPTER 6	CONCLUSIONS AND RECOMMENDATIONS	205
6.1	Selection of optimal gully geometry	205
6.2	Recommendations for low stress conditions	207
6.2.1	Options for gully geometry	207
6.2.2	Support practices	208
6.3	Recommendations for moderate stress conditions	210
6.3.1	Options for gully geometry	210
6.3.2	Support practices	211
6.4	Recommendations for high stress conditions	212
6.4.1	Options for gully geometry	212
6.4.2	Support practices	214
6.5	Steep dip	215
6.6	Blasting practice	216
6.6.1	Wide headings	216
6.6.2	Footwall lifted gullies	217
6.6.3	Advanced strike gullies	217
6.6.4	Lagging sidings	217
	BIBLIOGRAPHY	218
	APPENDIX 1	225

LIST OF TABLES

Table 2.1	Tendon support requirements to restrain falls over gullies
Table 2.2	Proportion of industry wide rock related fatalities that are gully related
Table 2.3	Comparison of gully accidents in different mining districts
Table 3.1	The number of gullies visited as a function of reef type and depth
Table 3.2	Summary of hangingwall and footwall characteristics for various reef types
Table 3.3	Gully standards in use on mines
Table 3.4	Dimensions for gully with no siding
Table 3.5	Dimensions for gully in line with the face
Table 3.6	Dimensions for ASG gully with lagging siding
Table 3.7	Dimensions for gully with wide heading
Table 3.8	Dimensions for gully at the top of the panel
Table 4.1	Comparison of actual gully width to mine standard
Table 5.1	Basic criteria used in numerical models
Table 5.2	Rock material properties used in numerical models
Table 6.1	Stress categories used for gully selection

LIST OF FIGURES

- Figure 2.1 Plan of resuing drive, used at Crown mines (after Walton, 1929)
- Figure 2.2 Early application of wide headings at 2000m to 2500m depth at Robinson Deep (after Fouché, 1954)
- Figure 2.3 Gully layouts (cf. Rockfalls and Rockburst, 1977)
- Figure 2.4 A schematic diagram of shallow mining stope layout.
- Figure 2.5 A schematic representation of intermediate depth scattered mining layout
- Figure 2.6 A schematic representation of a deep level longwall mining layout
- Figure 2.7 Fracture and deformation patterns around a deep stope.
- Figure 2.8 Typical expected fracture pattern around a deep mine gully (c.f. Rockfalls and rockbursts, 1988 ed.)
- Figure 2.9 The layout used in 104/38 W1 carrying only the gully ahead of the face as an advanced heading and the resultant fracture pattern.
- Figure 2.10 The likely fracturing around a gully-width advance heading developed in the footwall of the stope
- Figure 2.11 Underhand siding face forms steep fractures
- Figure 2.12 Strike gully along A-B
- Figure 2.13 The layout and resulting fracture pattern for mining with a 10m wide advanced heading, 5-10m ahead of the face (after Tucker, 1987)
- Figure 2.14 Fracturing around gullies in deep stopes
- Figure 2.15 The layout for mining with no advanced gully heading and the resultant fracture pattern
- Figure 2.16 Configuration of a wide advance heading and a strongly underhand face used at ERPM
- Figure 2.17 A Schematic of expected fracture pattern for ASG configuration
B Schematic of expected fracture pattern for Follow Behind Gully configuration
- Figure 2.18 A plan of a lead, or north side, between two panels showing the face shape (solid line) which it is usually tried to maintain by blasting and the shape (dashed line) which the face tends to assume
- Figure 2.19 Fall of ground geometry and distribution
- Figure 2.20 Ideal gully pack performance
- Figure 2.21 3 main stages of deterioration

- Figure 3.1 Gully types in use on platinum mines
- Figure 3.2 Gully types in use on gold mines
- Figure 3.3 No siding
- Figure 3.4 Gully in line with the face
- Figure 3.5 ASG gully heading with lagging siding
- Figure 3.6 Wide heading
- Figure 3.7 Gully at the top of the panel
- Figure 3.8 Gully edge support types
- Figure 3.9 Basic hangingwall support
- Figure 3.10 Tendon length and depth
-
- Figure 4.1 Comparison of measured and standard gully widths for cases examined underground. Considerable deviations from intended mine standards are apparent
- Figure 4.2 Normalised gully widths as a function of mining depth
- Figure 4.3 Deviation from standard gully widths as a function of depth. Observed gully widths are normalised against mine standard widths
- Figure 4.4 Measured gully spans and widths on a platinum mine
- Figure 4.5 Relationship between gully width and span between support across when normalised against standard dimensions
- Figure 4.6 Frequency of occurrence of gully width, normalised to the mine standard width of 1.2 m
- Figure 4.7 Frequency of occurrence of spans between support across platinum mine gullies, normalised to the mine standard span of 2 m
- Figure 4.8 Observed spacing of packs along gully shoulders at various mines industry-wide, shown versus mining depth
- Figure 4.9 Observed spacing of packs along gully shoulders at various mines industry-wide, normalised to local mine standard values, shown versus mining depth
- Figure 4.10 Gully cut in high stope width area in competent, jointed strata on the Beatrix Reef at approximately 900m depth. The gully is in the centre of a panel, mining high channel widths, and is very stable, tending to break out along joints
- Figure 4.11 Brow in massive bedded quartzite over a gully on the Beatrix reef at 900 m depth

- Figure 4.12 Hazard resulting from joint bound wedges over a strike gully on the Merensky Reef at approximately 300 m depth. An additional pillar is left on the updip side of the gully to reduce the risk of a fall
- Figure 4.13 Zone of dense jointing creating a hazard on the Merensky Reef at 600 m depth. Siding left on the left side of gully and additional in stope pillar left on right
- Figure 4.14 Crush pillar directly adjacent to a gully is yielding in response to stope closure, resulting in slabbing being pushed, or toppling into the gully Merensky Reef 700 m depth
- Figure 4.15 Gully with no siding on the Merensky Reef at 800 m depth. Conditions are stable, although spalling has clearly occurred along the pillar sides. Note that pillar edge damage runs up and into the hangingwall
- Figure 4.16 Merensky Reef showing a short, 0.5 m siding blasted concurrently with gully advance using a single comer hole
- Figure 4.17 Merensky Reef – lagging 1m wide supported siding
- Figure 4.18 Merensky Reef gully with 1 m siding and timber elongate providing the only support, on both sides of the gully
- Figure 4.19 Merensky Reef gully where a crush pillar lies on the gully edge and during crushing has damaged the hangingwall resulting in mesh and lacing application to control minor falls
- Figure 4.20 Merensky Reef – no siding. Severe spalling downdip
- Figure 4.21 Gully with lagging siding. Downdip siding has a flat floor due to stress fracture damage. Downdip packs are vertical
- Figure 4.22 Merensky – footwall lifted gully in wide heading. Due to downdip sidewall integrity, all packs are normal to dip
- Figure 4.23 Merensky Reef – conditions in a wide heading with footwall lifted gully
- Figure 4.24 Conditions along a footwall lifted gully on the Merensky Reef. Note backfill installed on the downdip side
- Figure 4.25 Basal Reef – gully excavated with no siding with stress damage causing downdip sidewall and hangingwall instability
- Figure 4.26 Basal Reef – collapse of gully hangingwall due to fracturing developed around leading ASG heading
- Figure 4.27 Basal Reef – the effect of a lagging siding on hangingwall conditions – view from face area looking back along gully
- Figure 4.28 Basal Reef – combined effect of an ASG heading, plus a lagging siding when strata is well bedded

- Figure 4.29 Typical high-density stress fracturing in gully shoulders in VCR footwall quartzites
- Figure 4.30 VCR under high stress – gully advanced as an ASG with lagging siding at 2800 m depth
- Figure 4.31 Typical VCR gully damage resulting from the use of an ASG with a lagging siding under high stress conditions
- Figure 4.32 Typical wedge shaped fall caused by the interaction of jointing and stress fracturing around a lagging siding on the VCR
- Figure 4.33 VCR –typical conditions that may develop along a gully created as an ASG with lagging siding under high stress
- Figure 4.34 Carbon Leader wide heading footwall lifted gully with good hangingwall conditions at 3200 m depth
- Figure 4.35 VCR – footwall lifted gully – good hangingwall conditions
- Figure 4.36 Collapse back along a gully as a result of seismic activity. The hangingwall has collapsed between packs up to a bedding parting. Rebars are snapped or exposed
- Figure 4.37 Collapse of a reef drive on the VCR horizon due to ejection of packs from the siding by a seismic event
- Figure 4.38 On reef trackless roadway supported with trusses and cribbing
- Figure 4.39 Roadway after seismic damage – packs collapsed, trusses and hangingwall intact
- Figure 4.40 Ground consolidation by injection grouting in the partially collapsed hangingwall of a VCR strike gully at 2800 m depth
- Figure 4.41 Resin injection used to consolidate a collapse area over a carbon leader dip gully at 3000 m depth
- Figure 4.42 Strike gully on Carbon Leader Reef at 2900 m depth, where a stable long term access has been achieved through using sets and void filling
- Figure 4.43 Development type round with a burn cut, used to advance as ASG-type gully, here shown in a high stope width area at shallow depth
- Figure 4.44 View into a carbon leader wide heading with a footwall lifted gully showing the face charged up and ready to blast. The cut is out of sight on the updip side. Good condition exist over the gully
- Figure 4.45 VCR – poor footwall lifted gully conditions resulting from blasting practice where holes are drilled downward into the stope footwall and long distance of gully is ripped simultaneously
- Figure 4.46 Gully ripping blasting practice in a wide heading

- Figure 4.47 VCR – good blasting practice – footwall lifted gully advanced incrementally by drilling horizontally in the gully face
- Figure 4.48 Scraper erodes updip sidewall of gully beneath packs
- Figure 4.49 Correctly constructed packs, normal to reef, prestressed, with grout bag
- Figure 4.50 Gully shoulder and hangingwall unevenness results in uneven compression of pack and its eventual disintegration
- Figure 4.51 Comparison of gully conditions versus depth in Bushveld platinum mines
- Figure 4.52 Comparison of gully conditions versus depth in Witwatersrand gold mines
-
- Figure 5.1 Numerical modelling flowchart
- Figure 5.2 Example of the mining geometry used in two-dimensional FLAC models
- Figure 5.3 Example of the mining geometry used in three-dimensional FLAC3D models
- Figure 5.4 Example of the mining geometry represented in two – mining step FLAC models of platinum mine gullies. Plan shows lines of section represented by mining steps modelled
- Figure 5.5 Sketch sections of gully geometries modelled, showing monitoring points used in the analysis
- Figures 5.6 Example of model results showing zone damage, stress distribution and shear strain. Models with a 3m wide pillar with and without a siding between gully and pillar
- Figure 5.7 Strains recorded at the four gully-wall-monitoring points in the model
- Figure 5.8 Comparison of modelled horizontal and vertical closures in gullies with adjacent pillars
- Figure 5.9 Peak strain values in the edge of the pillar nearest to gully
- Figure 5.10 Effect of k ratio on gully stability.
- Figure 5.11 Strains recorded at four gully-wall-monitoring points in models with k ratios of 0.5, 1 and 2
- Figure 5.12 Comparison of modelled horizontal and vertical closures in gullies with k ratios of 0.5, 1 and 2
- Figure 5.13 Deeper mining gully layouts modelled using FLAC
- Figure 5.14 Deeper mining gully layouts modelled in two dimensions using FLAC

- Figure 5.15 Sequence of plots showing the change in conditions around a gully advanced as an ASG, with stope and siding subsequently excavated around it
- Figure 5.16 Case of gully, face and siding all advanced in line. Hangingwall and footwall strain is relatively consistent at the gully
- Figure 5.17 Rock mass behaviour when gully is excavated in a wide heading. In the top view only the heading and gully are excavated, with the updip stope added in the lower view
- Figure 5.18 Comparison of peak stress levels applied to gully walls throughout each model analysis
- Figure 5.19 Comparison of final strains induced in gully walls throughout each model analysis
- Figure 5.20 Comparison of vertical and horizontal closures between gully walls at the end of each model analysis
- Figure 5.21 Stress field around modelled gullies on an overhand environment with generalised abutment stress conditions
- Figure 5.22 A simple 45 degree rule for siting footwall lifted gullies in an overhand mining configuration
- Figure 5.23 Examples of excavations modelled using FLAC 3D. Views show ASG with lagging siding and wide heading cases
- Figure 5.24 Points where data was extracted from models, corresponding to initiation points for stress fracturing that may influence gully sidewall and hangingwall stability
- Figure 5.25 View of an ASG model where the gully leads the stope face and siding by 2m. The hangingwall is removed to show the model geometry and the rock mass is coloured according to stress level. Note that even a 2m ASG at 3000m depth appears to penetrate the high stress zone ahead of the stope face
- Figure 5.26 Oblique view of a section parallel to reef at mid-height through an ASG, and siding at 3000m depth, showing the extent of rock mass damage, and vectors indicating the stress path curving around and over the ASG heading
- Figure 5.27 Comparison of stress values recorded at the five monitoring points in the single step FLAC3D model
- Figure 5.28 Comparison of shear strain values recorded at the five monitoring points in the single step FLAC3D model

- Figure 5.29 Stereographic plots showing poles to planes of anticipated stress induced fractures in the gully shoulders and hangingwall in ASG and wide heading cases
- Figure 5.30 Orientation of anticipated stress fractures in the hangingwall, around the face area of various gullies. Fracture strike relative to gully direction is shown in the upper graph, with fracture dip below.
- Figure 5.31 The influence of siding lagging distance on ASG sidewall conditions. The lag is the distance from the ASG face to the siding
- Figure 5.32 The influence of the width of a wide heading on strain induced in the hangingwall of the gully at the heading face
- Figure 5.33 Orientation of anticipated stress fractures in the hangingwall, around the face area of various widths of wide headings.
- Figure 5.34 The influence of wide heading lead distance ahead of the stope panel on strain induced in the hangingwall of the gully at the heading face
- Figure 5.35 Sequence of advance in the ASG case, showing points at which strains, stresses and closures across the gully were monitored. Lower points shows numbering used in this report for the sequence of points within each monitoring ring
- Figure 5.36 Comparison of stresses induced at monitoring points in the four sequentially mined models. Four points in one monitoring ring are shown for each mining step
- Figure 5.37 Comparison of strains induced at monitoring points in the four sequentially mined models. Four points in one monitoring ring are shown for each mining step
- Figure 5.38 Change in vertical hangingwall movement in the hangingwall over each gully as mining advances
- Figure 5.39 Changes in horizontal closure across each gully as mining advances
- Figure 6.1 Recommended gully geometries as a function of mining depth in gold and platinum mines
- Figure 6.2 Recommended tributary areas for calculation of required gully support pressures in low stress mining areas
- Figure 6.3 A simple 45-degree rule for siting footwall lifted gullies in an overhand mining configuration

Definitions

The following definitions are provided to assist in understanding gully terminology in the South African mining context:

Advanced strike gully (ASG) is a form of strike gully where the gully is developed ahead of the stope panel face without carrying a wide heading or siding.

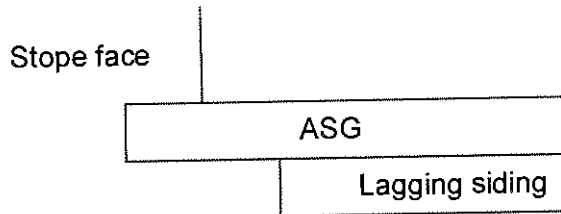

Brow a step in the hangingwall of a stope where the stoping width has been reduced (AAC, 1992).

Bull horns Curved steel hooks, which can be built, or hammered, into timber packs to support steel or timber sets.

Centre gully a raise is referred to as a Centre gully after stoping from that raise has commenced (AAC, 1992).

Closure the reduction in width or height of an underground opening as a result of combined elastic and inelastic deformation.

Deformation a change in shape or size of a solid body (COMRO, 1987).

Dip the true dip of a plane is the angle that it makes with a horizontal plane – the angle being measured in a direction perpendicular to the strike of the plane (Whitten and Brooks, 1972).

Elongate timber pole used for stope support. Usually designed to have some form of yielding mechanism, through machining or the use of a steel sleeve. It may be prestressable.

Failure failure in rocks means exceeding of maximum strength of the rock or exceeding the stress or strain requirement of a specific design (COMRO, 1987).

Fault a fracture or fracture zone along which there has been displacement of the two sides relative to one another parallel to the fracture. (The displacement may be a few centimeters or many kilometers) (COMRO, 1987).

Fracture the general term for any mechanical discontinuity in the rock; it therefore is the collective term for joints, faults, cracks etc (COMRO, 1987).

Footwall geologically the strata below a reef. Also used generally to indicate the floor of an underground excavation, irrespective of rock type (AAC, 1992).

Footwall lifting the excavation of a gully behind the face in the mined out area in a stope by means of blasting a simple trench in the stope footwall.

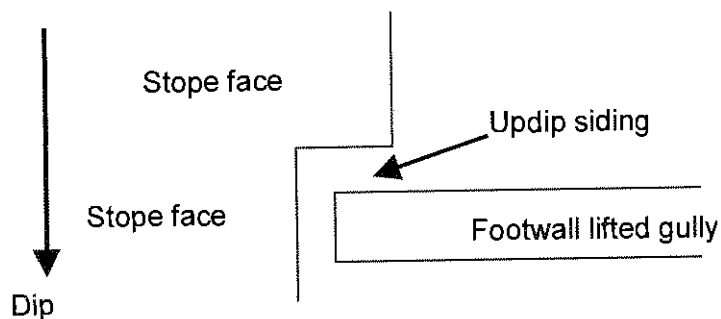

Gully is an excavation cut in the immediate footwall or hangingwall of the reef for the purpose of enabling the removal of rock from the face or providing access to the face for men or material.

Hangingwall mass of rock above a discontinuity surface e.g. the rock above the reef (Spearing, 1995).

Joint a break of geological origin in the continuity of a body of rock occurring either single, or more frequently in a set or system, but not attended by visible movement parallel to the surface of the discontinuity (COMRO, 1987).

Longwall Mining it is a specialised technique used in deep mines where the rock stresses are so great that development must remain in the destressed area

behind the stope face. Mining system in which all stope faces are aligned or slightly staggered in a regular manner.

Overbreak the quantity of rock that is removed beyond the planned perimeter of the final excavation (Spearing, 1995).

Overhand Mining:

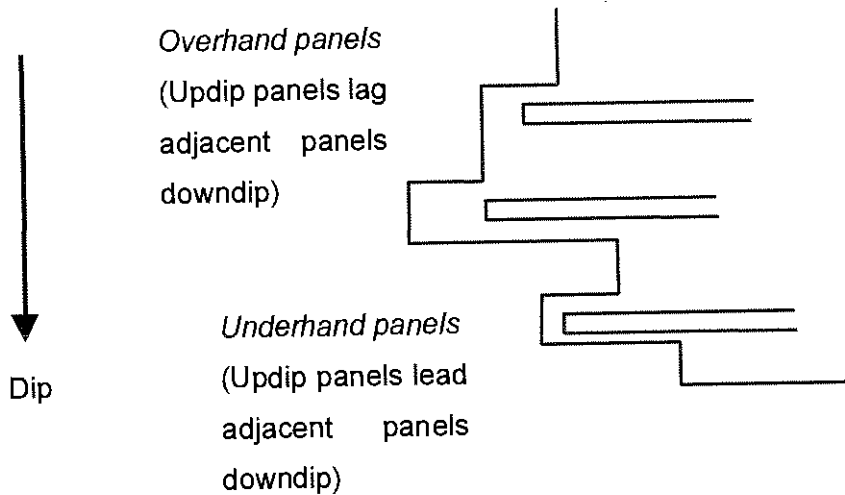

Packs support units used in stopes and along the edge of gullies comprising layers of timber poles, timber mats, concrete bricks or specially engineered units.

Panel a section of stope face usually 30metres long (AAC, 1992).

Prestressing to provide an immediately active support pressure, packs or elongates can be prestressed using grout-filled bags, hydraulically inflated steel units or other means.

Pillar a block of ore entirely surrounded by stoping, left intentionally for purposes of ground control or on account of low value (Spalding, 1949).

Rebar this term generally refers to a shepherd's crook rebar, a steel reinforcing bar grouted securely into a hole in the rock to provide support. The unit is not pretensioned and is a passive form of support, becoming effective once grout has set. The end protruding from the hole is normally doubled over to form a loop that can be used for lacing.

Reef Drive horizontal tunnel developed on reef.

Rock anchor a steel rod or cable installed in a hole in rock; in principle same as rock bolt, but generally used for rods longer than about four meters. (COMRO, 1987).

Rock any naturally formed aggregate of mineral matter occurring in large masses or fragments (Spearing, 1995).

Rock bolt a steel rod placed in a hole drilled in rock used to tie the rock together. One end of the rod is firmly anchored in the hole by means of a mechanical device and/or grout, and the threaded projecting end is equipped with a nut and plate which bears against the rock surface. The rock bolt can be pretensioned (COMRO, 1987).

Rockburst seismic event that causes damage to underground workings (Spearing, 1995).

Rockfall fall of rock fragment or a portion of fractured rock mass without the simultaneous occurrence of a seismic event (Spearing, 1995).

Sets and cribbing timber or steel poles (sets), often supported between packs across a gully, used to support very loose ground. The space above the timber sets, up to the rock hangingwall, is frequently packed with a loose arrangement of shorter timber pieces (cribbing).

Shaft a vertical or inclined opening to provide access to or ventilation for a mine.

Siding a cut, taken at reef elevation on either the downdip or updip side of the gully, with the objective of moving the gully away from high stress concentrations and fracturing associated with solid mining abutments.

Sliping process of widening underground openings (AAC, 1992).

Sticks temporary support consisting of single wooden poles (AAC, 1992).

Stoping is the process by which the orebody is broken and extracted from the working stope face for subsequent transport to the shaft and hoisting to surface.

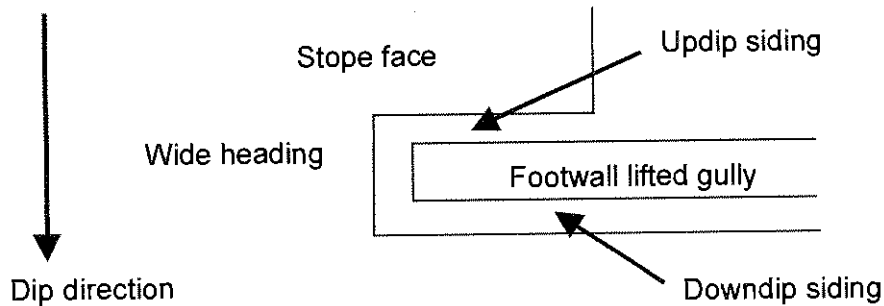

Strike gully the gully at the bottom of a stope panel, running on the strike of the reef. Broken ore is scraped down the stope face into the strike gully and along the strike gully into the boxhole.

Shotcrete mortar or concrete conveyed through a hose and pneumatically projected at high velocity onto a surface. Can be applied by a "wet" or "dry" mix method (COMRO, 1987).

Slabbing the loosening and breaking away of relatively large flat pieces of rock from the excavated surface, either immediately after, or some time after excavation. Often occurring as tensile breaks which can be recognized by the subconchoidal surfaces left on remaining rock surface (COMRO, 1987).

Spalling a) longitudinal splitting in uniaxial compression
b) Breaking-off of plate like pieces from a free rock surface (COMRO, 1987).

Stability the condition of a structure or a mass of material when it is able to support the applied stress for a long time without suffering any significant deformation or movement that is not reversed by the release of stress (COMRO, 1987).

Stress force acting across a given surface element, divided by the area of the element (COMRO, 1987).

Strike the direction of azimuth of a horizontal line in the plane of an inclined stratum, joint, fault, cleavage plane or other planar feature within a rock mass (COMRO, 1987).

Structure one of the larger features of a rock mass, like bedding, foliation, jointing, cleavage or brecciation; also the sum total of such features as contrasted with texture. Also in a broader sense, it refers to the structural features of an area such as anticlines or synclines (COMRO, 1987).

Support structure or structural feature built into an underground opening for maintaining its stability (COMRO, 1987).

Scattered mining a mining method whereby strike-parallel footwall haulages are developed on a number of levels, crosscuts are driven to reef and raises are established on reef. Stopping is carried out on either side of each raise and as far as possible all payable ore is removed, including final remnants between raises.

Sequential grid mining an adaptation of scattered mining for deep operations. Development in the form of crosscuts and raises is created on a regularly spaced grid and mining is carried out sequentially in each raise line to minimise stress concentrations on stope panel faces. In general regional support is provided by dip pillars left between raiselines.

Travellingway is an inclined development providing access from a crosscut to a raise or between levels.

CHAPTER 1 - INTRODUCTION

It has been observed that gullies pose a serious problem in many tabular mines with regard to stability of the gully sidewall and roof. From a safety perspective it has been recorded that the second highest number of fatalities occur in gullies as a result of falls of ground (Wilson, 1970 and Roberts & Jager, 1992). Coggan (1986) reinforces this by saying that the gully / face area is one of particular danger, and its layout and support need to be re-thought. It can thus be seen that support and layout in gullies is of major concern and as a consequence should be addressed as a priority.

This project reviews current practices with regard to gully geometry and excavation sequence as well as the associated hazards. The project is aimed at deriving practical industry guidelines, for strike gully layouts and geometry and support at all depths as a means to reducing the incidence of fall of ground accidents.

The MSc project concentrates on the following areas of concern:

1. A thorough literature review of past-recommended gully practices in gold and platinum mines in South Africa.
2. A review of current gully practices used on the gold and platinum mines based upon underground observations, mine standards and codes of practice. Problem areas, as well as successful solutions, are identified.
3. Numerical modelling to back - analyse certain conditions observed underground. In particular focus is on confirming optimal widths of sidings, optimal gully heading geometry practices on various reefs, and identification of mining depth constraints where gully sidings are required.
4. Compilation of broad summary guidelines for mining practices with respect to stope gullies.

A simple definition of a gully based on the Department of Minerals and Energy (DME) (1996) is an excavation cut in the immediate footwall or hangingwall of the reef for

the purpose of enabling the removal of rock from the face or providing access to the face for men or material.

A gully is considered to be an important feature in mining. This is because it provides an accessway for people and material to get to the work face. It can be regarded as the “artery” in mining, as it provides a myriad of uses to assist in cleaning and taking out the ore and providing services. Gullies also add to the efficiency of mining, and can be used in shallow mines as an exploration tool to determine the grade.

Stope gullies form one of the most hazardous areas in gold and platinum tabular reef type deposits, (17% of all fatalities in 1990, COMRO 1992). There are numerous reasons why this is so and a brief summary includes the following.

- Due to requirements for access to stope faces, movement of materials and cleaning, spans tend to be wider between supports at the gully face; hence the potential for instability may be greater than elsewhere in the stope face.
- For cleaning purposes, gullies generally lead the stope panel face. This can lead to interacting fracture patterns and broken ground conditions towards the bottom of a panel face. Varying fracture patterns can develop around a leading gully due to the presence, or absence, of sidings.
- Development-type blasting techniques can increase hangingwall damage over a gully.
- Where gullies have solid ground either up or downdip, sidings are frequently cut to move areas of intense stress fracturing away from gully positions. Depending upon timing of excavation of siding, and siding width, gullies may still be rendered unstable due to stress damage.
- In shallow mines, sidings are less of a requirement, however if stress damage occurs or joints are intersected, slabs can spall into a gully. Hangingwall problems have occurred in some shallow mines where gullies are adjacent to support pillars, and no sidings are cut.

- Gully width and the nature, or absence, of support in the gully hangingwall can greatly affect the stability in seismic conditions. Given suitably unfavourable conditions gullies can collapse far back into the mined out area.

As an example, figures published in 1975 and based on approximately 350 cases since the 1920's show in excess of 50% of all rock related mine fatalities to be associated with strike gullies with causes attributed to geological structure and inadequate support or layout (Chamber of Mines, 1977).

These are a few examples of gully problems that may arise, and solutions have been derived in practice to cope with most conditions. However, there can be reluctance on the part of mine personnel to implement optimal gully procedures due to the fact that problems are often intermittent in nature and corrective procedure often involves considerable additional effort, and, if not carried out correctly, can make situations worse. For example, cutting a siding on the downdip side of a gully generally involves time-consuming hand cleaning and as a result downdip sidings are often cut just deep enough to build a pack. If a seismic event occurs downdip of the gully there is no space for broken rock to move into behind packs and hence packs get forcibly ejected into the gully.

This report comprises two main sections. First a review of current gully practices on the gold and platinum mines, based on published information and data gathered from current mining operations. Second, an evaluation is made of the factors that influence gully hazards and design aspects that can alleviate or reduce these hazards. Finally, a set of simple guidelines for best gully practice is proposed.

CHAPTER 2 – LITERATURE REVIEW

This section provides a review of past literature relating to stope gullies. It examines the extent of current and past guidelines for gully behaviour, focussing on the nature of gully problems, design criteria, and areas where uncertainty exists or more detail can be provided as part of this project. There is very little information published on shallow mining stope gullies and the focus is on what happens under elevated stress conditions.

Since mining commenced in the Witwatersrand basin and Bushveld complex a considerable body of information has been published, pertaining to mining practices. Concerning stope gullies, the literature, spanning some seventy years, falls into two categories. The first comprises technical guidelines and competent analyses written by technical services staff or researchers. The second are the “what we did on our mine and wasn’t it great” type of papers, which often provide good examples of mine standards which illustrate the way in which the first category guidelines are conveniently manipulated in the face of mining practice. Most of the problems experienced as mining depths increase focus on alleviating stress related problems. In terms of this review, it is first worthwhile to consider the changes that have taken place in mining practices that have led, firstly, to the development of the current stope gully, and secondly the slow recognition of factors that cause gully problems and the methods devised to alleviate them.

On the basis of the literature survey it is clear that many of the primary causes of gully problems have probably been recognised for over 70 years. It is also clear that corrective action is largely unpopular, and has been repeatedly ignored, as it makes practical mining operations more complex. Most documented cases show that while mines recognise the need and are prepared to use sidings in areas of higher stress or rockburst hazard, the gully is invariably advanced as a heading with sidings cut some distance back whenever mining people feel they can get away with it. A clear trade-off has been (and still is applied), between optimising induced fracture geometry, and making mining operations easy as possible.

The literature is reviewed in this section under the following key areas:

- A historical perspective of the origins of gullies, recognition of problems and development of solutions.
- Types of mining, providing an insight into mining at various depths and the problems encountered, and where gullies are applied.
- Fracture patterns encountered in and around a gully and the effects of various gully geometries.
- Factors influencing gully conditions.
- Geological conditions on various reefs
- Support of Stope Gullies- what has been done in the last decade, what is being done at present.
- The impact of rockfalls and rockburst in gullies.

2.1 Historical perspective – the who, what and where in stope gullies

To put gully stability issues in perspective it is worthwhile to briefly review the literature in historical context.

If one were to journey back in time to see how mining has evolved in South Africa, literature from the first half of the twentieth century indicates that the term “gully” had not been adopted (Watermeyer and Hoffenberg, 1932). At that time, there were no gullies but instead on-reef drives, serving as both stope accesses, exploration drives and tramming routes for removal of broken rock. Mines have always needed access ways to get man and material in and broken rock out, and the stope gully developed in its current form when haulages moved off reef into the footwall. However the current stope gully is the product of a hundred years of development of on-reef access ways.

The term “gully” appears to have been introduced with the advent of the winch-pulled scraper, as a term for a dedicated cleaning route, cut as part of the stoping operation. Scrapers were first introduced on the Modderfontein “B” Gold Mine in 1924 (Butlin, 1924) but were still used infrequently in stopes in the 1940’s (Jeppe, 1946). Some tracked gullies were reported at that time.

By the 1960's a change had generally taken place in the way in which tabular mining was done, and stope gullies with scrapers were in use across the industry. As mining advanced to greater depths, there was a shift from on-reef drives carrying track-bound hoppers to scraper and boxhole layouts, with haulages sited in the footwall. This access layout is less prone to stress and rockburst damage. Using scrapers in smaller on-reef excavations improved mining efficiency. For a time these excavations were referred to as strike slusher drifts (SSDs), before strike gully became the generally applied term. A considerable volume of published literature pertaining to gully design methods originated at this time (Pretorius, 1958, Cook et. al., 1972).

During the 1980's replacement of scrapers with trackless LHD cleaning equipment became popular on certain mines, permitting greater flexibility in mining operations, but creating a wider in-stope gully (or roadway) excavation, accompanied by instability and, ultimately, higher operating costs.

Back in the 1920's, the hazards from rockburst and stress damage was well recognised and methods were sought to reduce the hazard. Possibly the earliest reference to using ledging as a means of protecting on-reef drives in areas of elevated stress or rockburst risk appears in the 1924 Witwatersrand Rockburst Committee Report. In that document the reference is to reef drives which at that time formed the primary on-reef access and cleaning ways, largely preceding the use of stope gullies. The 1924 Witwatersrand Rockburst Committee stipulated that in order to protect on-reef drives, up and downdip sidings should be cut for 15 m ahead of stope faces, and supported with packs or pigsties. This was normally done as part of the stoping operation, well after the drives were developed and was considered difficult and costly with blasted rock from the ledges interfering with tramming (Watermeyer and Hoffenberg, 1932). Crown Mines developed a method of cutting the ledge during development, tramming ore only and stowing waste rock in the ledges (resuing driving), Figure 2.1, hence meeting the recommended guideline and improving efficiency. The ledges were cut 16 feet (approximately 5 m) up and downdip of the drive.

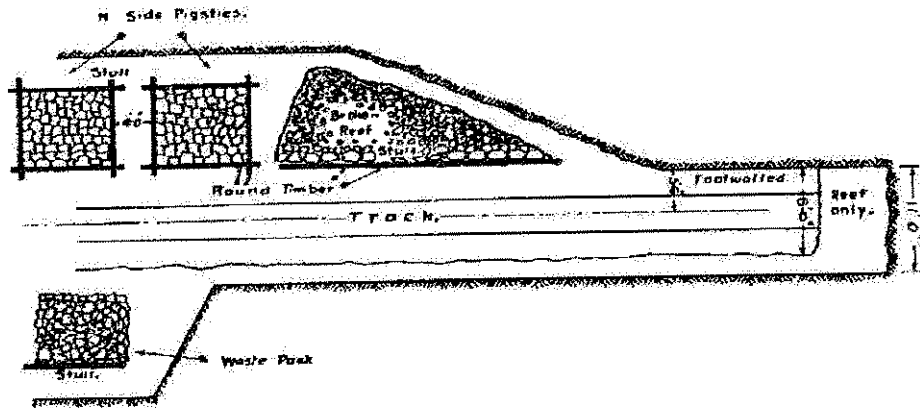

Figure 2.1 - Plan of resuing drive, used at Crown mines (after Walton, 1929)

Crown mines were not unique in applying sidings. For example, Mickel (1935) indicated that drives at 47 degree dip were ledged on the downdip side at Durban Roodepoort Deep, in areas where pressure bursts occurred.

The need for ledging was not universally accepted. Spalding (1949) stated that the practice of ledging drives ahead of stopes was in theory bad because it reduced the size of reef pillars between drives, elevating their stress, and because of low closure across short span ledged drives, contributing to deterioration of support. Spalding (1924) makes no mention of reducing stress damage to drive shoulders. While texts from the 1930's (e.g. Watermeyer and Hoffenberg, 1932) show sidings or ledges on most drives shown in mining layouts, by 1946, similar text books show a marked absence of sidings in mining layouts (Jeppe, 1946, Spalding, 1949). This is surprising, but it is likely that the use of ledging lost favour as greater mechanisation was introduced in the mines to raise production prior to, and during the Second World War, when milled tonnages increased from 30 million to over 60 million tons across the industry. The trend towards mechanical scraping was completed with an acute shortage of labour in the early 1950's, (Fouché, 1954) and highly labour intensive practices, such as the cutting of sidings appeared to have been discarded.

Despite unpopularity, footwall lifted gullies and wide headings were used in some deeper mines. One of the earliest references, shown in Figure 2.2 is from Robinson Deep (Fouché, 1954), where the intermediate drives (tracked strike gullies), were created by footwall-lifting between 2000 m and 2500 m depth. This was done either

within a wide heading, where panels were mined in-line, or within stope panels in an overhand configuration. The heading was 27 feet (8.2 m) wide; leading the stope face by 50 feet (15 m), with the gully lifted 8 feet (2.4 m) behind the heading face. Due to the excessive amount of work involved in cutting, supporting and equipping the intermediate drives, Fouché (1954) referred to a decision to return to stope panels of 300 feet (100 m) in length.

Pretorius (1971) pointed out the need for updip sidings on Crown Mines and City Deep, to ensure the stability of the updip gully sidewalls, providing solid pack foundations and hence minimising unsupported spans over gullies. However, as late as 1976, deep mines such as East Rand Proprietary Mines (ERPM) were still using an overhand mining layout (referred to as negative lead between panels), where the gully was positioned immediately downdip of the abutment formed by the lead between two panels. Until sidings were established updip of these gullies, extremely dangerous gully conditions were encountered (Smith and Ortlepp, 1976). Today, the merits of cutting sidings still get weighed against mining practicalities in shallower mines.

Renewed serious technical assessment of gully geometry and support came after 1960. In particular the necessity of adopting excavation shapes that manipulate, or optimise, stress fracture patterns to assist support was recognised (Muller *et al.*, 1968) and became well defined in the middle to late 1970's (Cook *et al.*, 1972, COMRO, 1977). A fundamental point is that the practice of introducing a siding or a ledge to move stress damage away from the gully position was a universally adopted recommendation from approximately 1970. An example of the variation in stope gully geometries that are, or have been, in use is shown in Figure 2.3 (COMRO, 1988).

In the mid 1970's research was based on trying to alleviate and optimise stress fracture patterns as mining progressed to depths of 3000m or more in mines such as Western Deep Levels and ERPM. The late 1980's to 1990's saw research focussed on support in mines (Squelch *et al.*, 1994, Roberts, 1995). Gully-support packs with tailored yieldability and stiffness characteristics have been introduced, after research into their required properties was completed in mid nineties (Roberts, 1995).

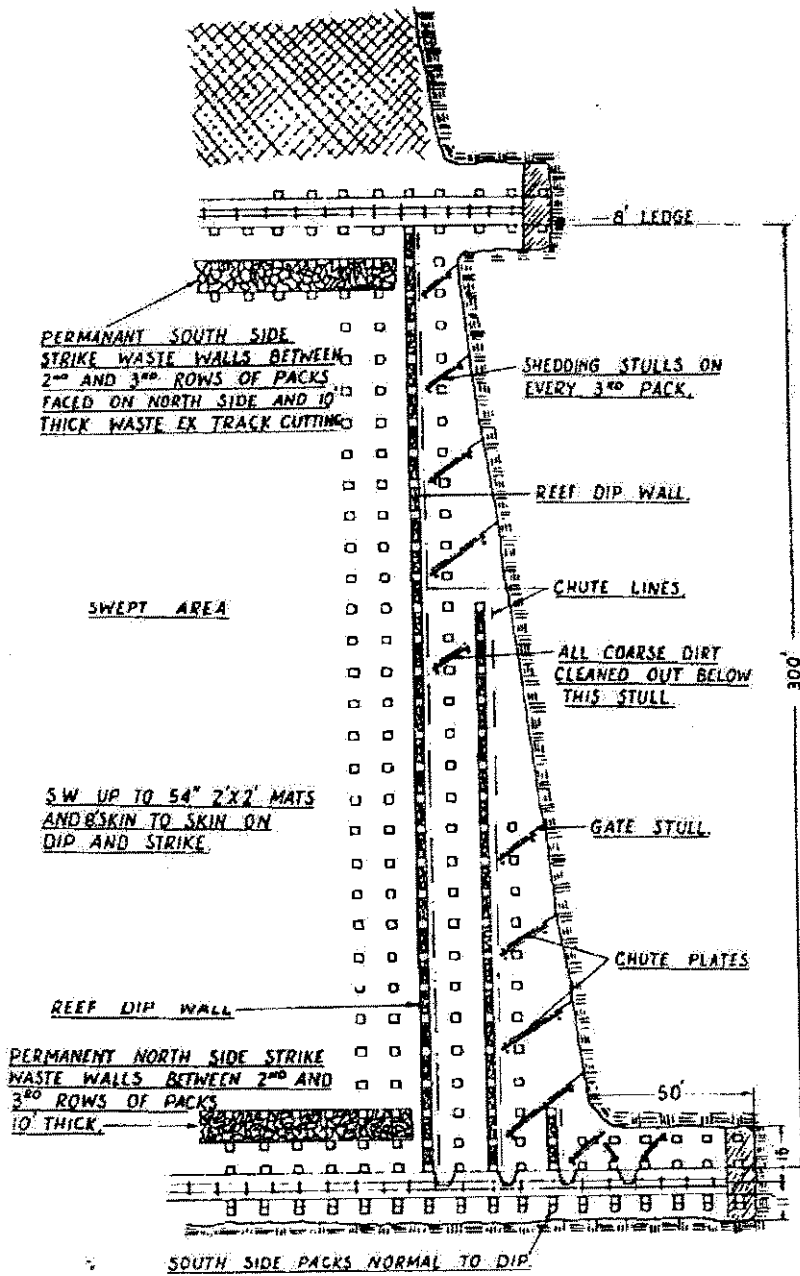

Figure 2.2 - Early application of wide headings at 2000 m to 2500 m depth at Robinson Deep (after Fouché, 1954)

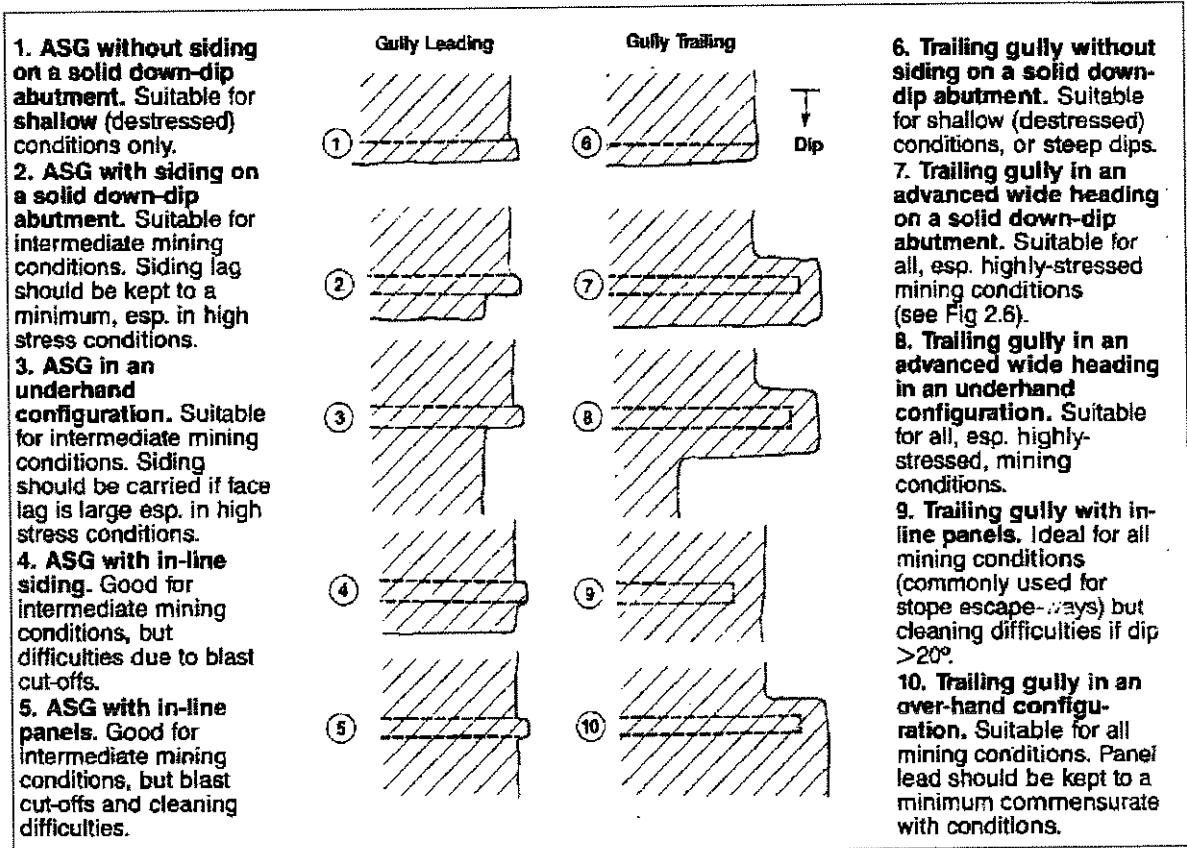

Figure 2.3 - Gully layouts (after COMRO, 1988)

Forty years later the gully layout recommendations originating between 1960 and 1970 are still generally accepted (Budavari, 1983, COMRO, 1988, Spearing, 1996, Jager and Ryder, 1999). While they have been fine-tuned, and certain new support techniques have been devised (Squelch *et al.*, 1994, Roberts, 1995, Adams *et al.*, 1999), advances have not been considerable. The early guidelines on strike gullies focused on stress and blasting practice related problems, with particular attention to deeper level mines. Most publications since the 1970's have provided similar information.

The hazards associated with gullies have long been acknowledged in print (Pretorius, 1971, Roberts and Jager, 1992, Bakker, 1995). The major hazards recognised result from seismicity and stress fracturing, even where, such as at intermediate depth, stress fracturing does not develop close to the stope face. Typically the identified causative problem areas included the following (COMRO, 1988):

- Poor blasting practice (too few holes and over-charging) caused damage to sidewalls and hangingwall.
- Long advance headings lead to adverse stress fracture geometries in gully sidewalls and hangingwall, coupled with a recognition that fracture patterns can be manipulated with sidings, or other changes to excavation geometry (Budavari, 1983).
- Gully shoulder damage required the use of long axis packs that are not unduly strong, to prevent collapse of the shoulders, consequential collapse of the pack, and loss of hangingwall support (Roberts, 1995). Until recently, solid mat packs were preferred. Now, engineered designs with near constant 1000 kN yield loads are recommended.
- Gully conditions in deeper, higher stressed, mining environments are improved where gullies are footwall lifted behind the stope face.
- Spans between support across gullies must be minimised, in particular in the area where the gully meets the bottom of a panel face, and provision must be made for additional hangingwall support, typically in the form of bolting, or timber/steel capping and cribbing.

A summary of the best recommendations from the literature follows. One of the objectives has been to critically assess the success of current industry gully methods. This was done by looking at current practice and comparing it to both past practices and recommendations, in terms of adherence to recommendations and, from the point of view of whether current methods proposed for gullies work successfully in achieving a safer environment.

2.2 Mining methods for various depths and associated gully considerations

2.2.1 Gully geometry options

One of the omissions from past guidelines is a methodology for deciding when and where different gully geometries are required, i.e. on a depth, stress, or reef basis. COMRO (1988) provides a broad-brush view for loosely defined shallow, intermediate, and deep mines. This was not intended by the authors to be prescriptive, but provides an indication of the conditions under which gully

geometries could be applied. No dimensions are recommended, except in the broadest terms.

Different types of mining sequences (scattered, longwall, bord and pillar, crush pillar systems, regional pillars and barrier pillars) have various adverse effects on the ground conditions. Increasing depth in scattered mining causes problems of high abutment stresses imposed on advanced haulages or on-reef development and the hazards of remnant extraction. Deep longwall mining strategies such as leaving regularly spaced stabilising pillars, mining through geological features, or leaving bracket pillars, attempt to alleviate hazards resulting from high stress and seismicity. Under the headings of shallow, intermediate and deep mining it is useful to first introduce the types of mining used and the kinds of gully geometry generally recommended in each.

2.2.2 Shallow depth

Shallow mining is defined in past literature (e.g. COMRO, 1988, Spearing, 1993) as mining which takes place at depths of less than 1000m below surface. Gay, Jager and Roberts (1988) defined characteristics of shallow mining as follows:

- Most of the rock surrounding excavations behaves elastically and is unfractured
- There is a zone over the stopes where the stresses acting on the rock are tensile
- Energy release rates in stopes are generally less than 10 MJ/m²
- Elastic closure in stopes is generally low, and is of great importance when selecting support systems for these excavations.

The techniques most associated with shallower depths include bord and pillar mining, either using stable pillars, or crush pillar systems in panels with regional pillars between raiselines. It should be noted that mining induced fractures are virtually absent. Gullies are cut without sidings and may be sited directly adjacent to pillars. At shallow depth, only discontinuities of geological origin will cause fall of ground hazards and include the following (Muller and Ortlepp, 1970):

- Sedimentary structures such as bedding surfaces, ripple marks and cross-bedding partings
- Tectonic features such as faults, slips and joints
- Intrusive features such as dykes, sills and mineralised veins.

The gully support in these areas should be stiff and gully spans should be kept to a minimum. Incompetent ground conditions require stiff packs or rock tendons. In competent ground sticks may be sufficient (COMRO, 1988). A schematic diagram (Figure 2.4) shows the type of mining layout used in shallow mines.

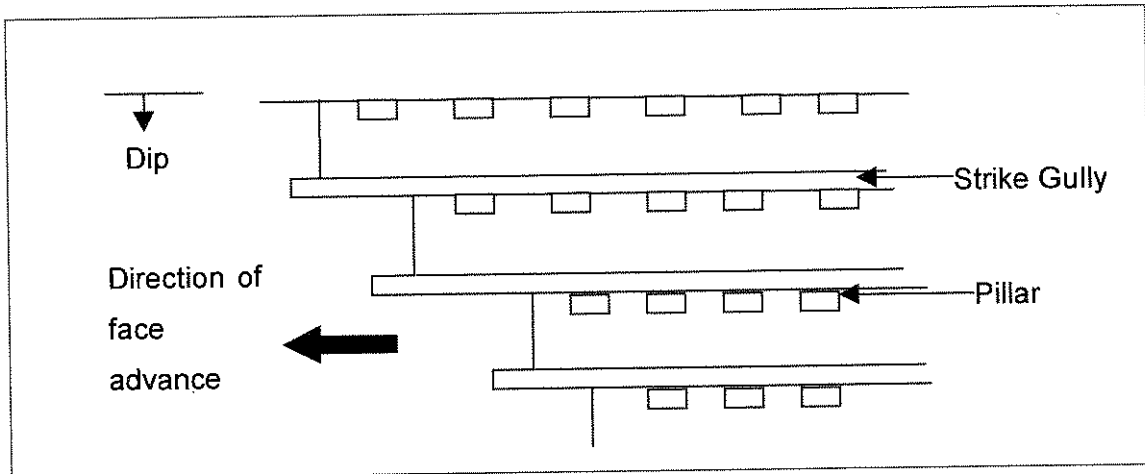

Figure 2.4 - Schematic diagram of shallow mining stope layout

2.2.3 Intermediate depth

COMRO (1988) speculatively suggest that intermediate depth mining takes place from 1000 metres to 2250 metres below surface, where stresses may cause fracturing and rock damage. However it should be noted that there is also no clear definition of where actual changes from one mining depth class to another should take place.

Some of the characteristics of mining at an intermediate depth include

- Moderate to high closure rates occur in remnants
- It is the start of stress fracture problems with severe stress fractures around pillars that have been left.
- Rock mass behaviour is influenced by a mix of geology, structure and the influence of stress fractures.
- Occurrence of moderate seismicity
- Energy release rates of approximately 10-20 mJ/m²

A scattered mining layout (Figure 2.5) is common at intermediate depth. Depending on stress levels, it is generally accepted that gully sidings are required, but often the

siding is cut behind the gully face, which is advanced as an ASG. Gully support may be yielding, comprising packs and possibly hangingwall tendons.

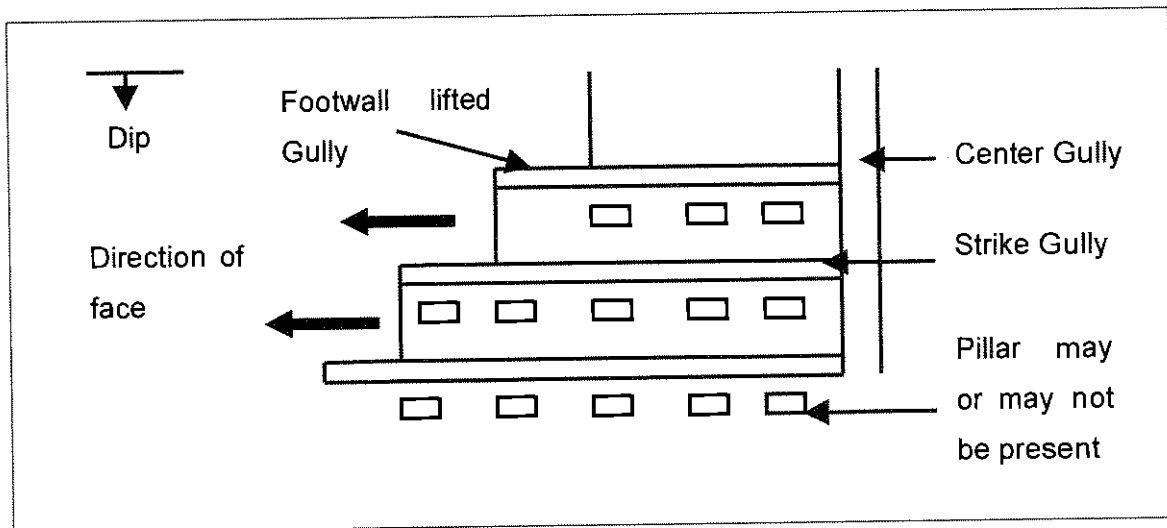

Figure 2.5 - Schematic representation of an intermediate depth scattered mining layout.

2.2.4 Deep level mining

Deep mining conditions are encountered when mining takes place at depths from 2250m to 3500m or at a depth where the energy release rate is greater than 20 MJ/m² (COMRO, 1988). Rock mass behaviour is dominated by high seismicity and high stress. Mining induced fractures are the dominant discontinuity in the rockmass and are the most widespread cause of all hanging-control problems (Muller and Ortlepp, 1970). Muller and Ortlepp (1970) indicated that mining at great depth would result in certain stress-induced dislocations in addition to the geological features that may be classified as follows:

- In stoping i.e. face-induced fractures, fractures parallel to pre-developed drives, burst fractures
- In tunnels i.e. sidewall slabbing in pre-developed drives and stope-induced 'jointing' in post-developed drives.

For deep level mining the longwall technique (Figure 2.6) was in the past considered to be an ideal situation as there was a reduction in the formation of hazardous remnant situations (COMRO, 1977, 1988).

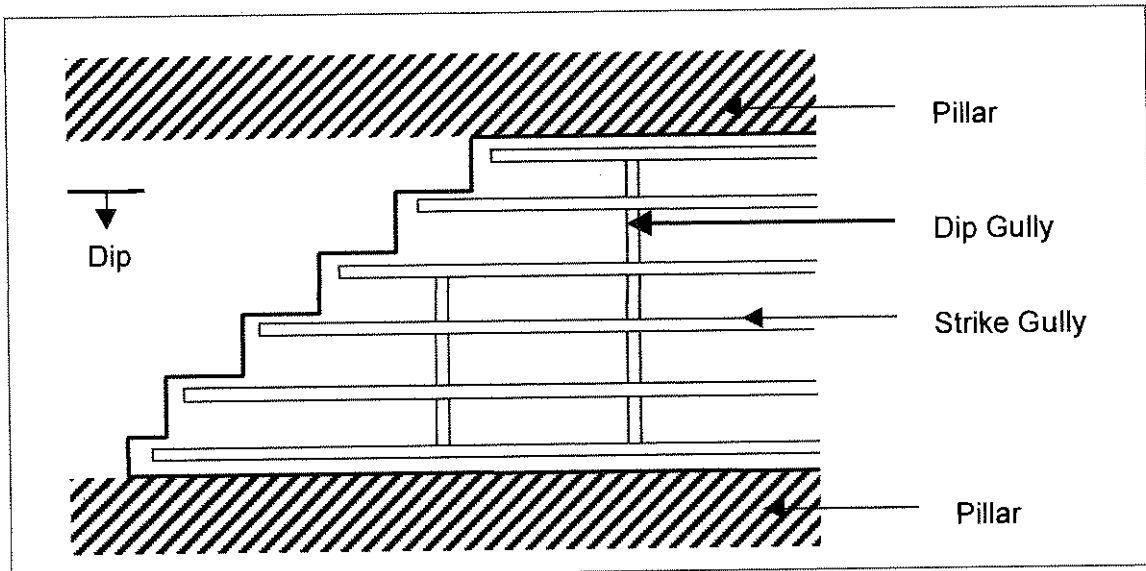

Figure 2.6 - Schematic representation of a deep level longwall-mining layout.

Seismicity problems associated with longwalling led to the use of regional support such as stabilising pillars, stiff backfill and bracket pillars on geological weaknesses (Jager and Ryder, 1999). Stabilising pillars were first introduced in the mid 1960's on ERPM (Ortlepp and Steele, 1973). The introduction of pillars led to a reduction in seismicity and associated rockbursts (Salamon and Wagner, 1979, Hobday and Leach, 1991). Stabilising pillars have resulted in considerable damage in strike gullies directly updip of them (Hagan, 1984).

An alternative deep level mining method is the sequential grid system of mining, (Applegate, 1993), which involves using a grid of pre-development similar to scattered layouts, with breast mining up to dip pillars left permanently unmined (Jager and Ryder, 1999). A variation of this method is called scattered mining with dip pillars (SMDP). Jager and Ryder (1999) described this method as a pair of relatively long oblique-faced panels mining downdip (or updip) feeding into a central raise, and flanked by dip stabilising pillars. This method allows more flexibility in terms of negotiating geological structures as compared to the strike stabilising pillar longwall layout.

At great depth the main issue for gullies relates to accommodating stress fracturing. In all methods the bottom access gully for each level may lie along the edge of the stabilising pillar. Consequently it can be subjected to high levels of stress and associated fracturing and would be severely damaged by seismic activity that occurs

within the pillar (Hagan, 1984, Turner, 1987). Sidings are essential under high stress, and footwall lifting of gullies within wide heading is a generally recommended practice, either for bottom gullies or where underhand face shapes are used. Alternatively gullies are footwall lifted within panels, away from abutments. Clearly stress and associated fracturing are the most significant factors that influence gully stability at depth. The nature of fracturing around stopes and gullies is reviewed in the next section.

2.3 Fracturing in gullies

2.3.1 General stress fracture pattern in a stoping environment

All stoping takes place within an environment of discontinuous rock. If mining methods are to be improved then fractures and deformation of the discontinuous rock must be understood (Adams *et al.*, 1981) together with their interaction with geological structure. Various authors have made classifications of mining induced fractures since 1958. Pretorius (1958) identified fractures, which were inclined to the vertical with a distinct component of displacement. The fracture planes comprised zones of broken rock material.

Kersten (1969) was the first person to classify mining-induced fractures that form in deep level gold mines. He made allowances for three classes namely:

Class 1: fractures which reveal no movement parallel to the fracture surface and which were thought to have formed as a result of tensile stress.

Class 2: fractures which represent intermediate types and can, for example, refer to a class 1 fracture which has subsequently been subjected to later movements.

Class 3: fractures, which reveal distinct signs of movement, for example striations or powdered rock material on the fracture surface. He did not imply that the class 3 fractures were shear fractures. This view differed from that of Pretorius (1958).

McGarr (1971) divided mining induced fractures into two types, type 1 and type 2. If fractures in the hangingwall of a stope were considered then type 1 fractures dipped in the direction of face advance and type 2 fractures in the opposite direction.

Gay and Ortlepp (1978) related the type 2 or burst fractures to the mechanism of rockbursts.

Adams *et al.* (1981) also classified fractures into 3 types, namely

Type 1. Steep fractures parallel to the stope face without any displacement in the plane of the fracture.

Type 2. Inclined fractures parallel to the stope face with a component of displacement in the plane of the fracture.

Type 3. Low angle and vertical, younger fractures.

They stated that the rock around a stope failed in different ways giving rise to these three basic types of fractures. The complete profile of fractured rock around a large stope had not been determined but it is known that fracturing generally extends no more than 10m ahead of the face. There is evidence that the vertical extent of fracturing increases with increasing distance behind the face, until a limit of about 60m is reached 40m behind the face. The fracturing migrates steadily with the advancing face (Adams *et al.*, 1981).

Current thinking has simplified mining induced fracture classification to “extension” and “shear” fractures (Jager and Ryder, 1999). Simply this means that an extension fracture always lies perpendicular to the minor principal stress (in rock mechanics sign convention this is either the least compressive stress or a tensile stress). Therefore, extension fractures tend to be parallel to free-surfaces, generating hence the “bow wave” effect. Shear fractures are always angled between the major and minor principal stresses approximately $45^\circ \pm \phi/2$.

Ryder and Jager (1999) indicated that stress concentrations are largest immediately in front of stope faces and are particularly severe in abutments, remnants and pillars. In all but the shallowest stopes, stresses result in intense and characteristic patterns of fracturing (Figure 2.7). In deeper mines stress-induced fractures are the dominant discontinuities. These fractures are closely spaced (60mm to 1m apart), strike parallel to the face and dip of the strata. Figure 2.8 shows fracture zone around a deep stope (COMRO, 1988).

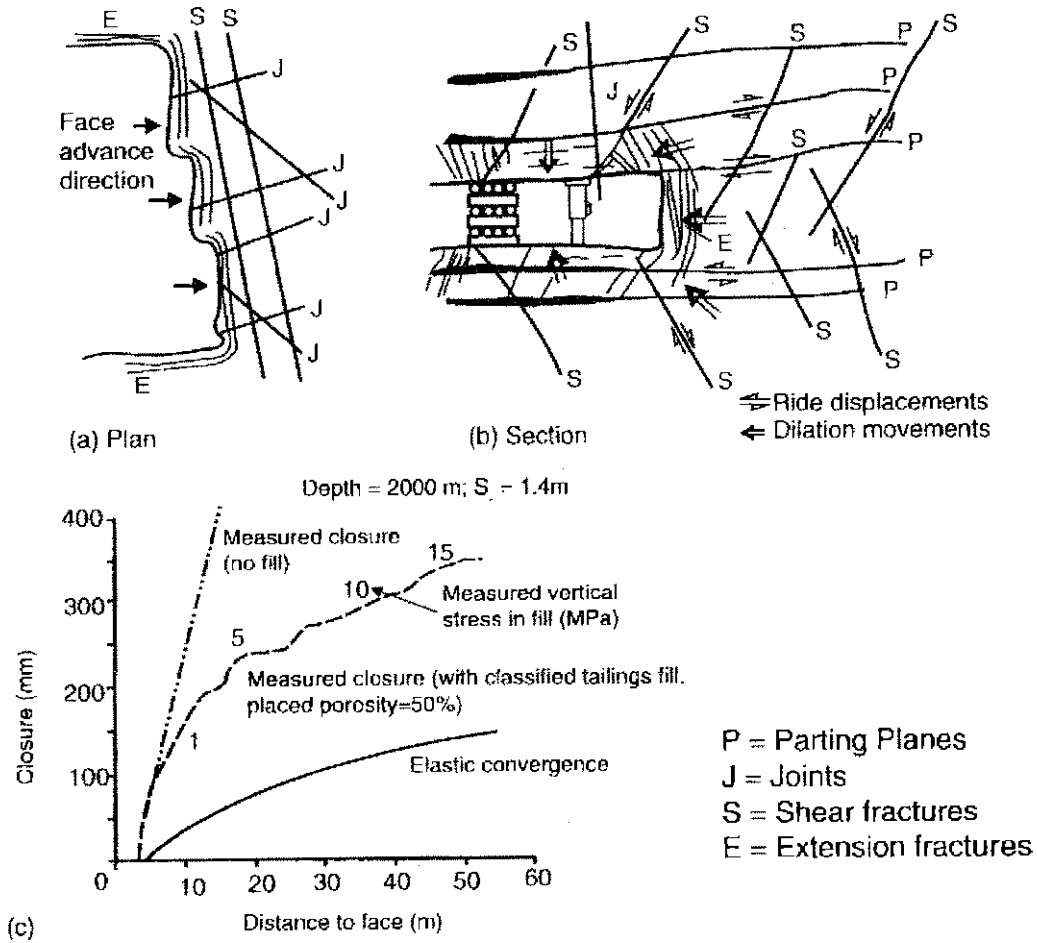

Figure 2.7 - Fracture and deformation patterns around a deep stope (after Jager and Ryder, 1999)

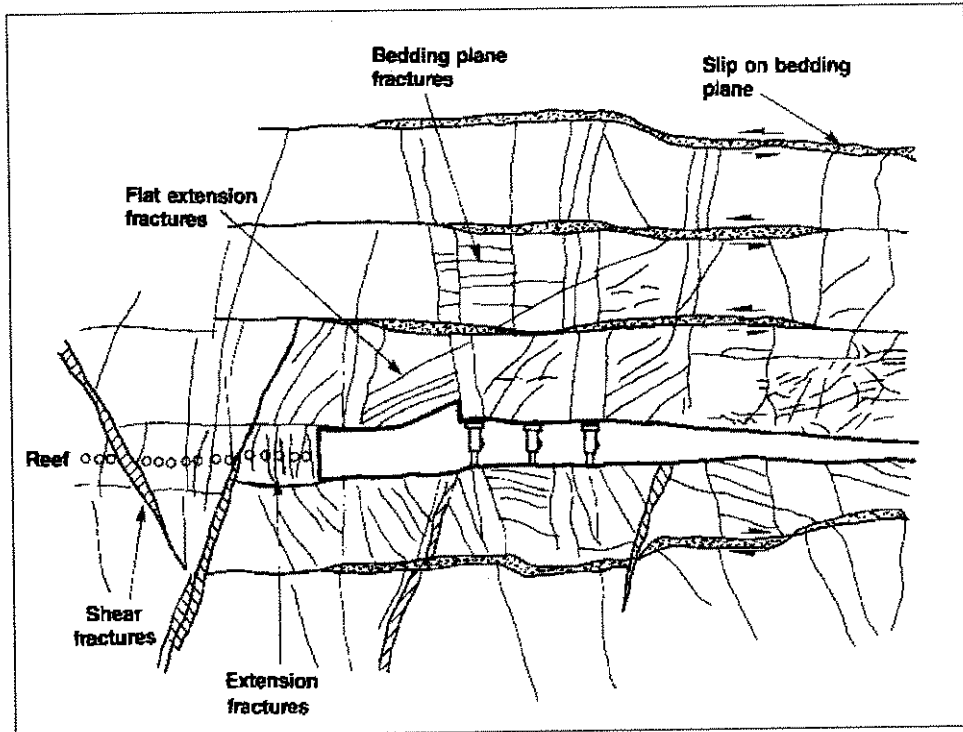

Figure 2.8 - Typical expected fracture pattern around a deep mine stope (after COMRO, 1988.)

2.3.2 Stress fracture patterns due to gully geometries.

Stress distributions and orientations in the vicinity of gullies are complex due to leads and lags between panels and the use of gully headings. This complexity has long been recognised and is well described by a number of authors (Budavari, 1983, Cook *et al.*, 1972, Smith & Ortlepp, 1976). A summary of typical stress fracture patterns, which tend to curve around gully excavation geometries, is presented below. The focus in gully geometry design for higher stress conditions is on manipulating stress fracture patterns to minimise hazardous fracture conditions in the immediate gully hangingwall. Turner (1985, 1987, 1990) in his investigations of various reefs on Western Deep Levels, ERPM and Vaal Reefs mines, indicated that the severity of hangingwall-parallel fracturing over gullies, that leads to falls of gully hangingwall, can possibly be reduced by modification of stope layouts. He also stated that the alternative to such fracture control might lie in better support systems.

Merson *et al.*, (1976), pointed out that gully stability was dependent on the orientation of fractures relative to the hangingwall and sidewalls of the gully. Ideally strike gullies should be excavated in such a way that the orientation of stress fractures

should be as near as possible to 90° to the gully direction. They noted that sidewall-parallel stress fractures around a gully heading could be avoided if the heading stayed within the stope face fracture zone. The following examples, largely from work by Turner (1987, 1990) illustrate how gully geometries may be used to modify fracture patterns.

2.3.3 Wide heading and footwall lifted gully

Wide headings have been widely advocated as a means of correctly orienting stress fractures in those cases where gullies have to be developed ahead of higher stressed stope faces (Merson *et al.*, 1976, Budavari, 1983, Jager and Ryder, 1999). As shown in Figure 2.9, stress fractures form parallel to the face and sides of the heading. However, Turner's (1987) observations for gullies of this type in bedded strata adjacent to stabilising pillars showed that fracturing developed over the gullies, and could be related to the use of the wide advance heading. He recommended that to reduce the fracture development wide headings should be dispensed with.

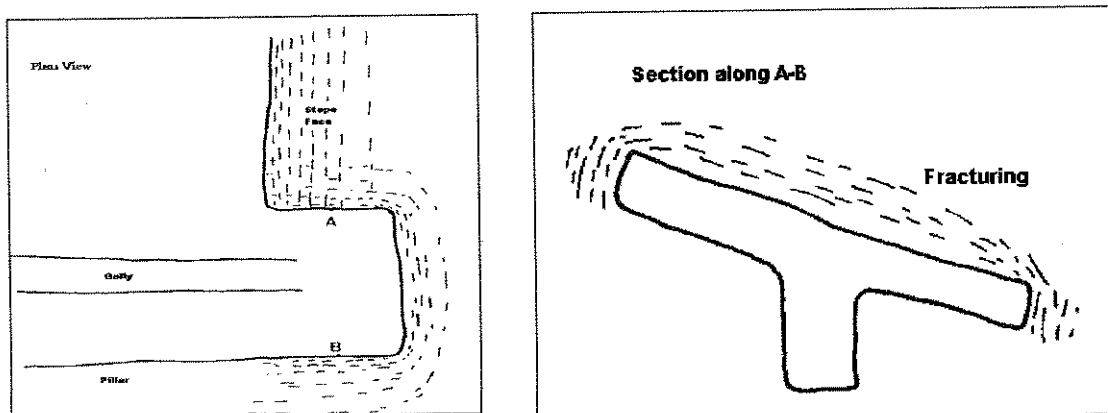

Figure 2.9 - The layout and resulting fracture pattern for mining with a 10m wide heading advanced 5-10m ahead of the face (after Turner, 1987)

Turner's MINSIM analyses showed that the horizontal stresses in the hangingwall remain high over a wide, advanced heading geometry. The perception that modifying the stope geometry could reduce stress and hence hangingwall parallel fractures led to the various other layouts being considered as alternatives to wide headings in a deep mining environment.

2.3.4 Mining with no gully heading

Turner (1987) indicated that the layout shown in Figure 2.10 would result in cleaning problems due to insufficient over-runs for the scraper. He suggested that an alternative scraper system might be a solution. But as a result of stress across the corner of the stope (A-B) some shallowly arched, hangingwall parallel fractures also occur with this geometry. He suggested that if a 15m or wider downdip gully siding were carried, it would remove the gully from beneath the shallow arch of hangingwall-parallel fractures. This would also result in the gully hangingwall being less likely to fall. In general, dependent on siding depth the method results in desirable stress fracture patterns.

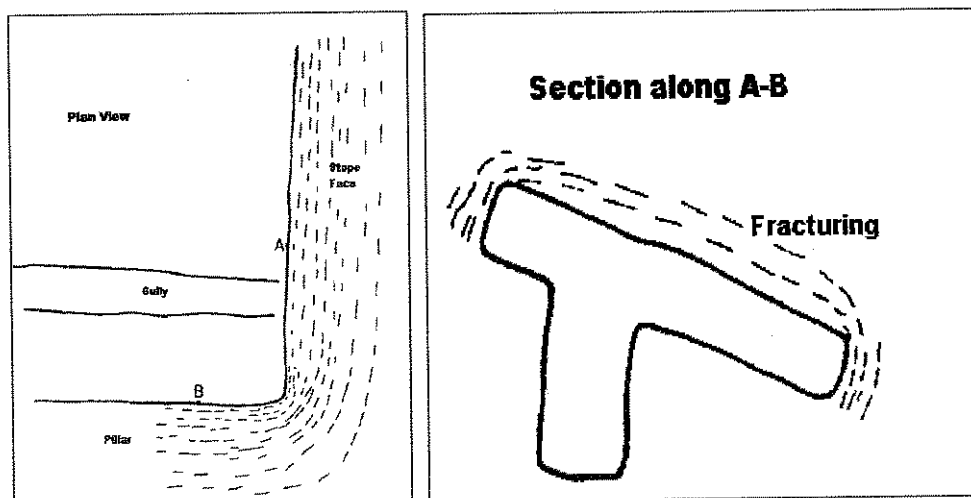

Figure 2.10 - The layout for mining with no advanced gully heading and the resultant fracture pattern (after Turner, 1987)

2.3.5 Mining with an ASG gully leading the stope face

ASG layouts, where the gully is developed ahead of the face with lagging sidings are favoured in many mines because of ease of mining operations. In general however low angle fractures develop back over the gully from the siding and result in instability (COMRO 1988).

The fracturing that occurs around a deep, highly stressed, advanced ASG at Western Deep Levels Mine was described in detail by Turner (1987), as part of his comparative study. A downdip siding was carried level with the stope face. The fracture pattern can be seen in Figure 2.11. As a result of the height of the

excavation at the gully face, it was possible to drill holes steeply into the relatively unfractured rock at the face and grout in Shepherd-crook bars. This partially stabilised the hangingwall. At this great depth stope face parallel fractures were seen 5m-6m ahead of the face and it was probable that the rock within that distance of the face had been partially destressed (Turner, 1987). It was considered advisable, however to keep the length of the gully ahead of the face as short as possible. Turner (1987) also stated the disadvantages of carrying a narrow, gully-wide development ahead of the face. He reasoned, that because of the development of gully-parallel fractures in the sidewalls of the heading which inflect below the stope footwall (P), this would lead to the footwall breaking away into the gully under the gully pack. This results in increased unsupported span across the gully. Merson *et al.* (1976) and Spengler (1986) recognised this problem also.

At more moderate stress levels on the Vaal Reef, Turner (1990) investigated several gullies using an ASG heading where the siding was permitted to lag behind the stope face. Three reasons for falls of ground in the gullies were identified, namely:

- Falls occurring during the ledging stage from the original raise and extending into the stope on either side of the gully. Turner (1990) attributed these falls to undercutting.
- Falls that occur as a result of low inclination (20° to 30°) fractures that extend up from the inter-panel face, in other words from the edge of the siding.
- Falls that results from the formation of a narrow arch of fractures over the gully around the ASG heading.

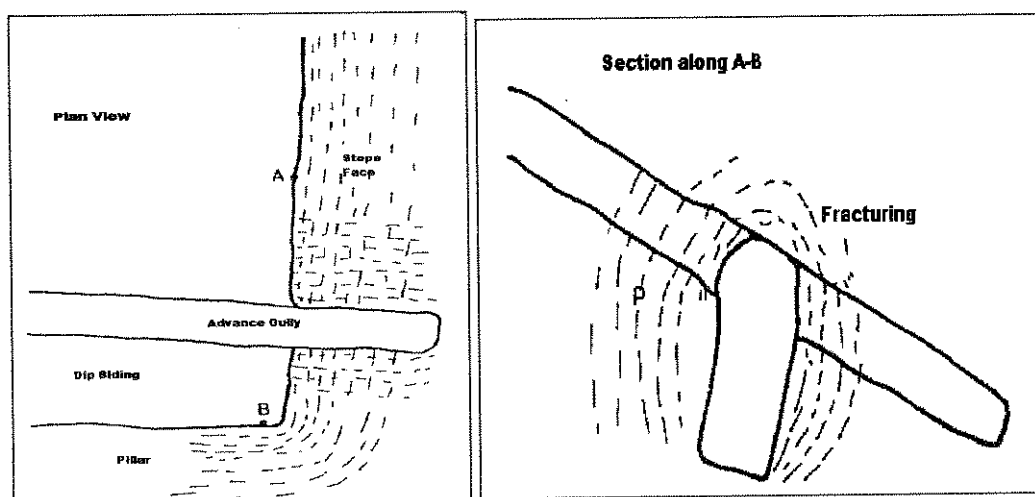

Figure 2.11 - A layout where the gully is carried ahead of the face as an advanced heading and the resultant fracture pattern (after Turner, 1987)

Advanced strike gullies (ASG's) have in the past been considered feasible where the narrow ASG heading is kept within the face-parallel stress fracture envelope. The ASG should not be so large to modify the normal fracture in front of the face (Cook *et al.*, 1972). However, the overall conclusion is that ASG methods with lagging sidings are undesirable generally. There have however been a number of attempts to make them work because they are favoured with the mining personnel.

One example, back at great depth, is shown in Figure 2.12. This is a variation of Figure 2.11, where the gully development is advanced below reef with its hangingwall level with the footwall of the stope. This moves the inflection (P) of the gully-parallel fracturing down. This would be more beneficial as the arch of the fractured gully hangingwall would be within the stope and would thus be mined out. In theory improve hangingwall and sidewall conditions should result.

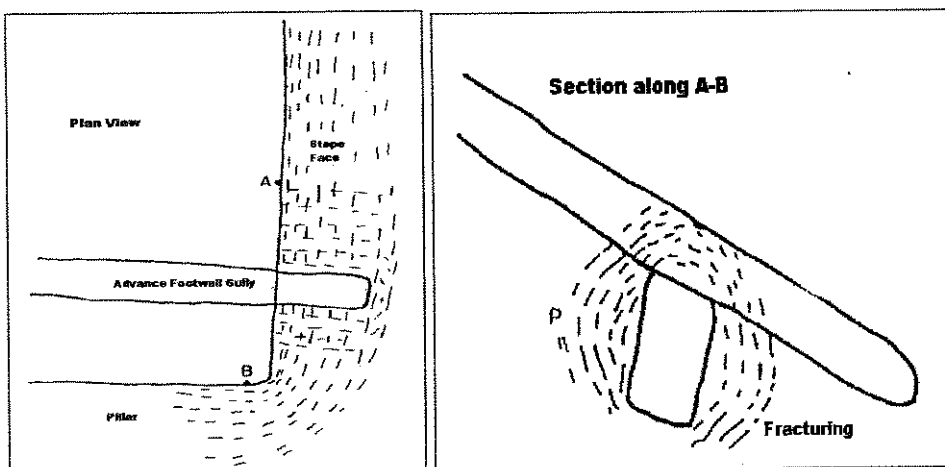

Figure 2.12 - The likely fracturing around a gully-width advance heading developed in the footwall of the stope (after Turner, 1987)

By changing the stope geometry layout in the immediate vicinity of the gully heading the local stress field will be altered and the orientation and extent of the fractures, especially the low inclination fractures, may be controlled. In most mining areas, these fractures propagate without interruption, within the face-parallel slabs, until they intersect the first poorly cohesive bedding surface (COMRO 1988).

In another ASG variant, Turner (1990) describes methods used on the Vaal Reef to attempt to reduce low angle fracturing. The gullies were mined as an advance strike gully one to four metres ahead of the face on the updip side, with the siding lagging

by four metres lag on the downdip side. In order to overcome the problems associated with low angle fractures a means was sought to introduce more favourable fractures at an earlier stage by introducing steep fractures. The shallow (1-2m) siding is breasted with a 45° underhand face. The steep face-parallel fractures formed ahead of this underhand face will, it was thought, block the propagation of the low inclination fractures from the inter-panel face on the downdip side of the siding. Figures 2.13 and 2.14 illustrate the principal used on the Vaal Reef.

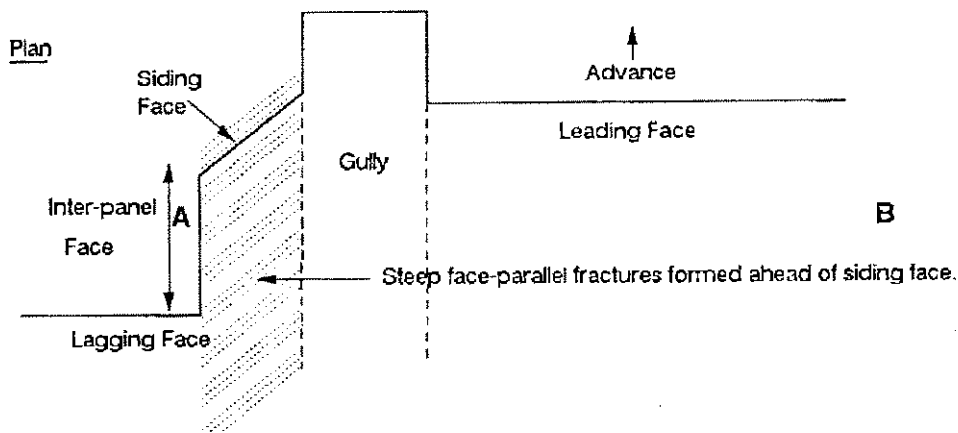

Figure 2.13 - Underhand siding face forms steep fractures to block low-inclination fracture propagation (after Turner, 1990)

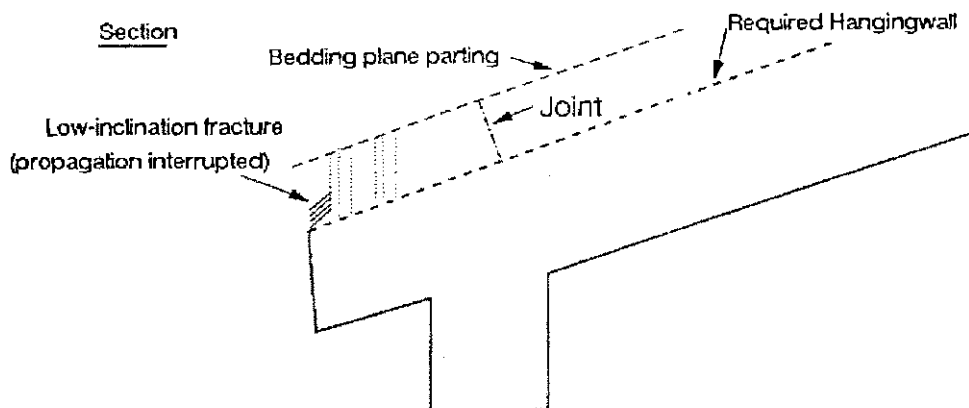

Figure 2.14 - Section through strike gully along A-B (after Turner, 1990), showing the propagation of low inclination fracture from the siding blocked by steep fractures

2.3.6 Mining a wide advance heading below an oblique underhand panel face

As an alternative to adjusting stress fracture patterns with the gully geometry, another option is to change the adjacent stope face orientation. One layout, described by Turner (1987), (Figure 2.15), was used at ERPM on the composite reefs, where the hangingwall parallel fractures were not developed. The absence of hangingwall-parallel fracturing was partially attributed to the presence of cross-bed partings in the hangingwall which preferentially slipped (Turner, 1987). These larger blocks are easier to support.

The fracturing ahead of the underhand face may modify the stresses significantly. By modifying stoping geometry it is possible to eliminate the intensive development of hangingwall parallel fractures, the only hangingwall-parallel detachment surfaces possible would be bedding-plane partings.

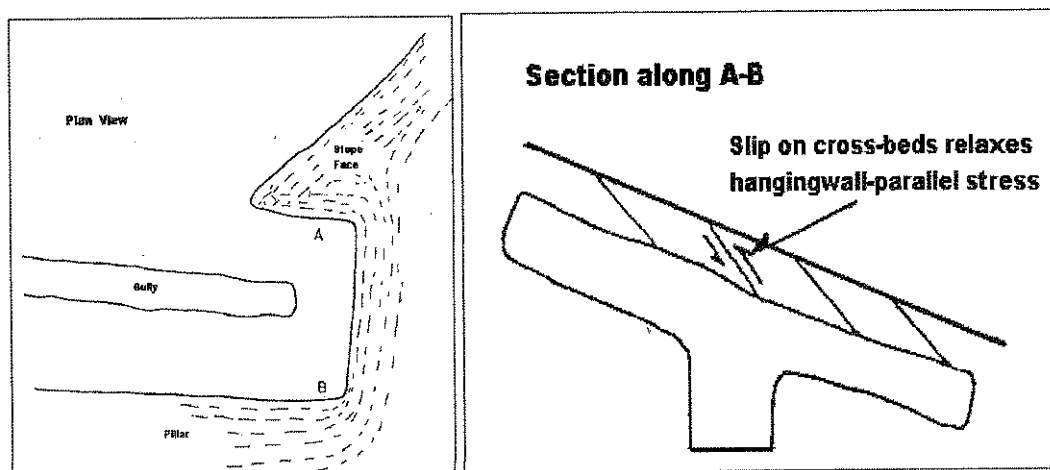

Figure 2.15 - The configuration of a wide advanced heading and a strongly underhand face as used at ERPM (after Turner, 1987)

2.3.7 Overhand versus underhand layouts

In overhand layouts where successive panels updip, lag behind the previous panel downdip, many gully problems can be eliminated because the stress induced fracture patterns develop around the stope face and the gully is blasted in the footwall behind the face after the fractures are formed. This layout is well favoured at all mining depths (Merson *et al.*, 1976, Diering 1987, Smith & Ortlepp, 1976). They are sometimes referred to as follow-behind gullies (Squelch *et al.*, 1995). Positioning of

these gullies relative to abutments is important. The types of fracturing which form around the gullies tend, together with the face-parallel fractures to produce prisms of rock that are slender, elongate normal to the gully axis and inclined to the plane of the stope, which is typical of a longwall follow behind situation. Squelch and Roberts (1995) compared follow behind gully and advanced strike gully configurations (Figure 2.15) on the Ventersdorp Contact Reef at Western Deep Levels South Mine. They found the follow behind case to be more stable, because the dominant fracturing would be parallel to the stope face and perpendicular to the line of the gully. Fracture patterns are compared in Figure 2.15.

2.4 Factors influencing gully conditions:

A number of factors can be listed (COMRO, 1988) that influence the conditions in gullies. These factors probably encompass gully stability at all mining depths:

- Ambient stress levels and the intensity and orientation of resulting fracturing around the gully, plus the degree of damage resulting from blasting practice and technique
- Quality, spacing and layout of gully support
- Width of the gully or heading and the gully depth
- The nature of the strata and geological features present.

Where gullies are developed near pillars or abutments, higher horizontal stresses are expected in the hangingwall together with a narrowing of the gully (Turner, 1987, Roberts, 1995). Adams *et al.* (1999) provided as a rule of thumb that gullies in deeper mines should be no closer than 6 m from a pillar or abutment as this will avoid high stresses and related displacements as well as adverse fracturing which may be associated with the abutment geometry. Geology is another factor that plays a major role in the behaviour of the rock at present depths and greater depths.

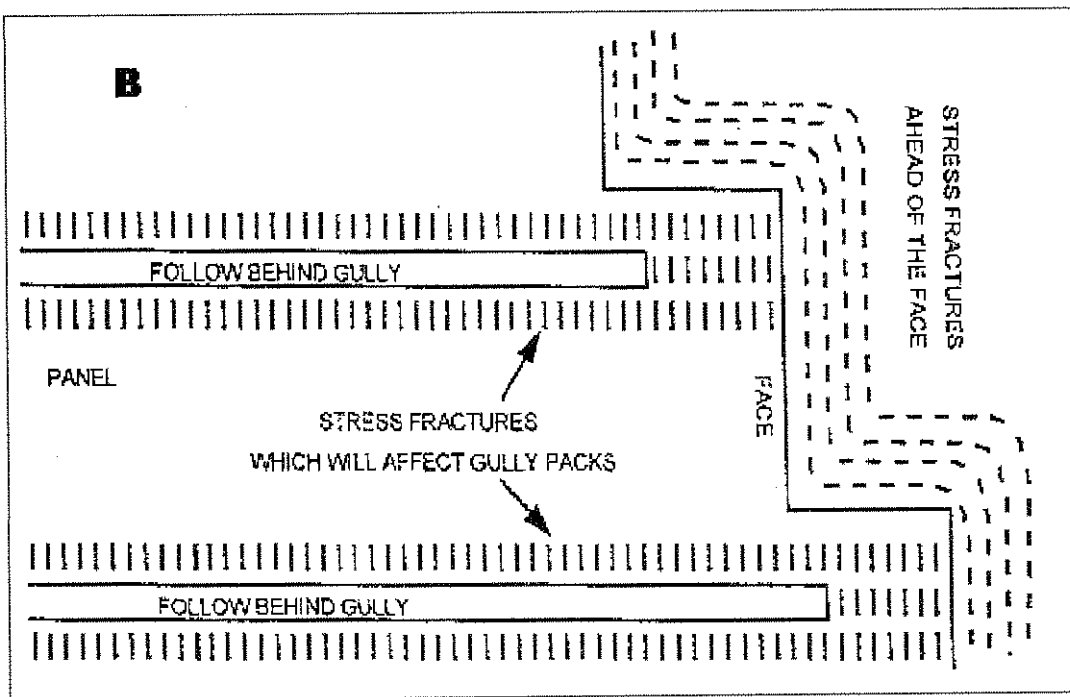
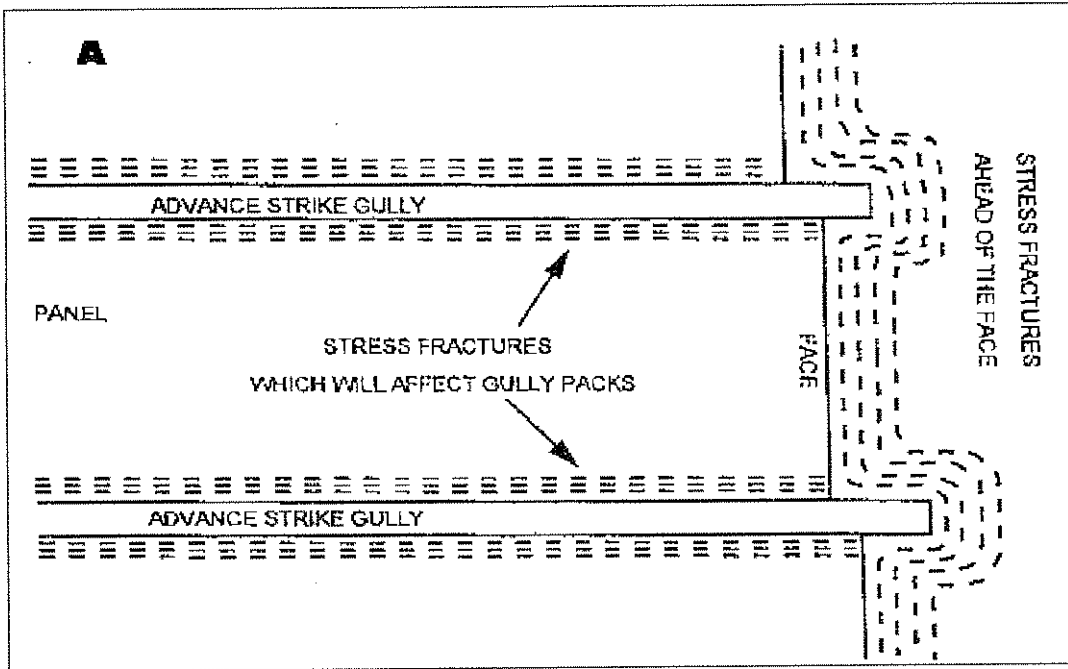

Figure 2.15 - A Schematic of expected fracture pattern for ASG configuration. B Schematic of expected fracture pattern for Follow Behind Gully configuration (after Squelch et al., 1995)

2.4.1 Gully geometry

The extent and intensity of the fracture zone increases with increasing depth. Figure 2.16 shows in summary how intensity, orientation and dip of fracture are modified as gullies and headings are modified ahead of the face in deep stopes. Fractures can cause hangingwall instability and sidewall failure around excavations, which can be reduced by minimising gully and heading leads as well as gully depth. What these layouts fail to include are layouts for mining at shallow depth, which include layouts with pillars and sidings.

2.4.2 Leads and lag

Positive leads create a problem of high stress concentrations adjacent to gully positions, potentially causing the hanging and footwall to become highly fractured. This results (Figure 2.17) in the toe of the lag at the bottom of the upper panel becoming badly damaged and a tight corner is formed at the leading top of the lower panel (Cook *et al.*, 1972). Distances should be kept as small as possible without compromising face area support.

Fracturing associated with lead/lag faces may cause problems at depth. Gullies should be sited further from pillars and as a result of increased fracturing associated with the mining faces; the need for aerial coverage will increase (Adams *et al.*, 1999).

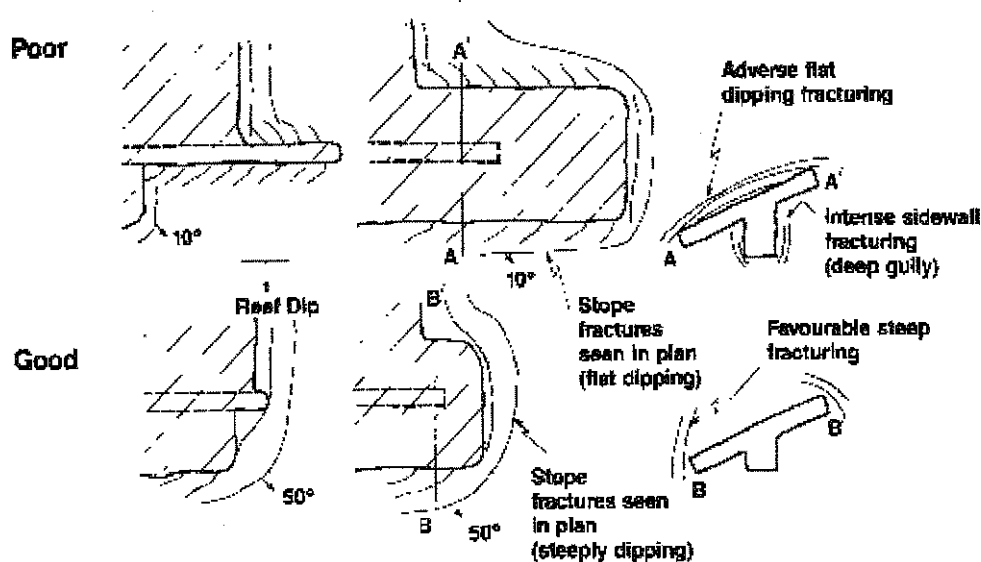

Figure 2.16 - Fracturing around gullies in deep stopes (after COMRO, 1988)

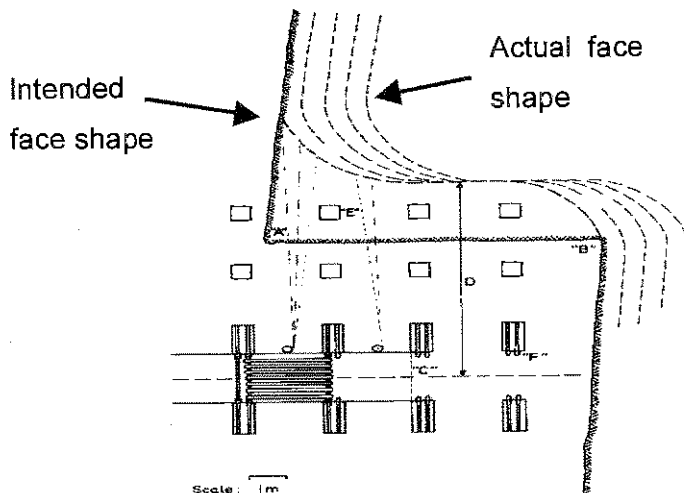

Figure 2.17 - A plan of a lead, or north side, between two panels showing the intended face shape (solid line) and the actual face shape (dashed line) (after Cook *et al* 1972)

With respect to lagging gullies, gully support should be installed as close to and as soon as possible to the leading stope face to limit the amount of inelastic closure (bedding separation and fracture opening). It is therefore important to have gullies close behind the leading stope face. It is expected that seismicity will increase with depth thus the ability of gully support to provide support to the hangingwall becomes crucial (Adams *et al.*, 1999).

2.4.3 Face shape

Sometimes the face has been allowed to assume the shape that results from the stresses that act on it. This principle avoided the need for excessive blasting of the face in the tight corner, and reduced the damage to the rock below the lead where the gully was situated. Changes included rounding off corners of the lead to a shape similar to the face, which can be seen in Figure 2.17, depicted by the dashed lines. Rounding off corners of the lead reduces the amount of intensely fractured rock on the protruding toe, A, of the lead eliminating the need for intense and excessive blasting in the tight corner, B, of the lead. Positioning the gully further from the lead moves it out of the zone of intensely fractured rock immediately below the lead. Smith and Ortlepp (1976) found that a distance of 3.6 m was suitable at ERPM.

To relieve the problems of maintaining strike gullies in good order, the face should be allowed to assume the shape shown by the dashed lines. The gully should be kept at least 8m below the lead, D, and the permanent gully support with rope slings for subsequent decking should be installed in advance of the gully, F. (Cook *et al.*, 1972). It will be seen in chapter 3 that current practice does not always follow these guidelines.

2.4.4 Blasting

The top 3m to 4m of a panel normally tend to lag behind the general line of the face. Drilling additional holes with smaller burdens is used to prevent this. These holes are usually over-charged with explosives, which causes excessive shattering of the surrounding rock. Similarly, there is a tendency to use too few holes and too many explosives in them when the gullies are excavated. This results in additional fracturing of the rock around the gully, which has already been damaged by the lead (Cook *et al.*, 1972). COMRO (1977) has also provided valuable input to the blasting layout of gullies.

The number of short holes and quantity of explosives are important in determining the condition of the gully (Adams *et al.*, 1999). The damage to the gullies can be alleviated to some extent and the stability of the gullies improved substantially by the following factors, which have been identified since 1972. The gully should be advanced only up to about the second row of packs from the face of the lower panel, C, Figure 2.17. These packs, if correctly installed, should at this stage have taken sufficient load to consolidate the footwall prior to blasting of the gully. A sufficient number of holes should be drilled in the face of the gully to eliminate overburdening, so that light charges will be sufficient to break footwall with minimum damage to the surrounding rock, particularly the rock forming the updip side of the gully (Cook *et al.*, 1972).

2.4.5 Depth of gully

If the depth of the gully were too shallow, it would result in insufficient storage capacity when boxholes or slusher gullies fill up as a result of tramming delays. Downdip side packs may foul the gully scraper; i.e. convergence will render the gully

too shallow for travelling and scraping; and gold-bearing fines may be lost in the downdip side waste filling.

If the gully is too deep, the updip side may become unstable. Also, unnecessary depth involves the excavation of additional waste rock, which often ends up in the reef tip. As the upper panel advances, a second cut can be taken to deepen the gully to the required depth, but only far enough ahead of the stope face to allow for an adequate overlap of the face and gully scrapers. Extra work is entailed but the situation is particularly difficult and the practice has been found to give excellent results (Cook *et al.*, 1972).

2.4.6 Width of the gully

Width and quality of the gully sidewalls have a strong influence on the gully hanging wall support. Many gully support problems are caused by poor gully sidewalls as a result of poor blasting practice.

It is advisable to keep the gully as narrow as possible. Adams *et al.* (1999) suggested that an ideal gully layout should have the gully as narrow as possible (1.6m) so as to minimise the span between gully supports. Gullies are often made too wide because of additional blasting of gullies, which have been developed off the correct line. A centreline must be established from survey pegs and painted on the hangingwall right up to the face of the panel or heading below it, so that packs are installed and the gully is excavated in the correct position to avoid subsequent slipping (Cook *et al.*, 1972).

Common knowledge would imply that an increase in seismicity would be expected with depth. It thus becomes important for the gully to be able to tolerate dynamic loading as well as to provide a support to the hangingwall. It is also expected that with increasing depth stresses will increase without a similar increase in rock strength. It can therefore be expected that fracturing of the rock increases and hence damage to excavation increases. It is expected that the conditions around the gullies will certainly be worse than in present deep level mines. (Adams *et al.*, 1999).

2.5 Geological considerations

From the previous sections it is clear that local geological structure can greatly influence rock mass stability. The following describe conditions on five different reefs where hangingwall quality ranges from massive competent rock to weaker interbedded quartzites and shale.

2.5.1 Gold reef types

2.5.1.1 Carbon Leader

Carbon Leader gullies are prone to damage as a result of the geotechnical properties of the hangingwall strata. It is overlain by a 1.4m to 4m thick competent siliceous quartzite. The Green Bar overlies this quartzite. Due to the poor cohesion between the hanging wall quartzite and the Green Bar, the quartzite beam is susceptible to fracture and collapse. A case in point to note is when the gully had been excavated along the lower edge of the stabilising pillar where a prominent set of mining induced fractures orientated parallel to the edge of the pillar was present, giving rise to poor hangingwall conditions (Durrheim *et al.*, 1998).

Strike gully sidings must be mined strictly on dip so that the Green Bar contact is kept a maximum distance above the stope. The final cleaning of the siding can take place from the following downdip panel where applicable (Durrheim *et al.*, 1998).

The hangingwall of Carbon Leader Reef stopes is similar in most mines with regard to rock type and the type and orientation of geological structures present. Figure 2.18 represents the typical areas of falls of ground that have been observed by Turner (1987). The areas of falls are shaded and the packs that have had to be rebuilt are hatched.

Smaller falls of ground (1m or less from the original hangingwall) might occur. Larger falls, (1.5-2m), of ground occur on the base of the Green Bar. Sometimes falls extend up into or through the Green Bar to expose the hangingwall of the Green Bar quartzite.

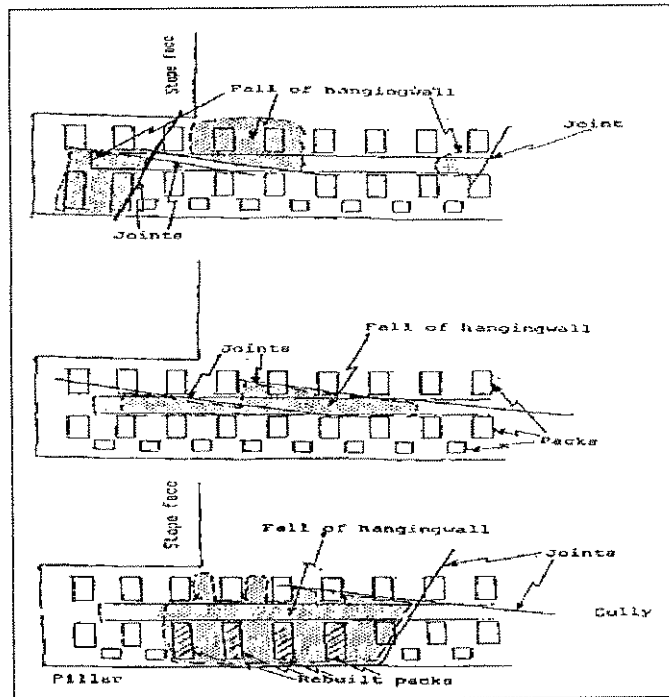

Figure 2.18 - Common falls of ground geometries and distributions, with respect to gullies and wide headings adjacent to stabilising pillars in Carbon Leader Reef (after Turner, 1987)

2.5.1.2 Ventersdorp Contact Reef (VCR)

In many areas the VCR is overlain by the Alberton Formation lava of the Ventersdorp Supergroup and underlain unconformably by the quartzites of the Central Rand Group. The channel varies from having only a hangingwall-footwall contact to a well developed reef 5m thick. On average the reef is approximately 1.2 -1.5m thick. Rolls and channels is a feature of the VCR.

The Alberton Formation lavas are strong and massive, steep dipping joints are the main structure with a limited number of reef-parallel flow bedding surfaces. At depth, these lavas prove very strong, very brittle, and a source of major seismic activity. Strain bursting is also expected.

In the Klerksdorp area the VCR is mined at a relatively shallow depth. A scattered mining method is used and the main support is by means of pillars, which are left in and alongside the panels. Roof bolts and profile props are used as hangingwall support.

In some areas the basal unit of the Ventersdorp Lavas is the weak, serpentinised and sheared Westonaria Formation. This is a highly plastic material, fractures readily and flows into excavations, whose stability becomes difficult to maintain at depth.

2.5.1.3 Basal Reef

The Basal Reef is mined in the Free State. It forms part of the Steyn Facies and is overlain by the Waxy Brown Leader Quartzite and underlain by the upper footwall 1 sequence. Scattered mining methods are used in most of the mines working this reef. Variations in layout result from reef dip and depth of mining. If the mining method is underhand, deterioration of the conditions in ASG's is problematical (Steyn, 2000). It is known that flat dipping fractures are difficult to support and that the conditions in ASG's are determined by stress fracturing and the way to alleviate this problem is through the use of sidings, which are frequently omitted because the dip exceeds 30 degrees.

2.5.2 Platinum reefs

2.5.2.1 Merensky Reef

The Merensky Reef in the western lobe of the Bushveld Complex has been subdivided into the Rustenburg Facies and the Swartklip Facies. The dividing line between these two facies is the Pilanesberg Complex. The Merensky Reef is contained, stratigraphically, within the Upper Critical Zone also known as the Mathalagame Norite - Anorthosite Formation of the Rustenburg Layered Suite.

The Merensky Reef refers to that part of the Merensky Unit that is mined. The Merensky unit is about 11 metres thick and consists of basal pegmatoid that is not always present. A pyroxenite layer that grades into a norite overlies this. Generally, the immediate hangingwall of the Merensky Reef is a pyroxenite, which is about 1.2 to 1.8 metres thick. Approximately 10 to 20 metres above the Merensky Reef is a 3 metre thick pyroxenite unit known as the Bastard Pyroxenite. The contact between this pyroxenite and the underlying mottled anorthosite is a sheared parting plane known locally as the Bastard Merensky Parting.

The presence of the Bastard Merensky Parting does not contribute directly to gully instabilities, however, to support the hangingwall up to the Bastard Merensky Parting a system of pillars are left insitu as timber support alone would be totally inadequate. This is because the thickness of the rock to be supported is 10m or more. The positioning of the pillars is normally on the immediate downdip side of the strike gully. At shallow depth, probably less than 500 metres below surface (depending on the overall percentage extraction), these pillars are essentially solid and do not fracture. At greater depths there is an increasing tendency for the pillar sidewalls to form slabs due to stress induced fracturing. Where these pillars are located immediately adjacent to the gully the slabs develop across the full height of the gully with the potential to peel off into the gully. To overcome this, a siding can be cut into the pillar, thereby removing the fracturing away from the gully edge and also reducing the height of the pillar. Where the pillars are not designed to crush, there is a tendency for the hangingwall to shear off next to the pillar. This creates loose hangingwall directly over the gully.

Potholes are a common occurrence in the Bushveld region. These are slump structures, which result in the reef cutting down to a lower footwall level. Generally they are not mined due to their size, depth of slump into the footwall and reduced grade due to thinning. An increased density of jointing is normally associated with ground surrounding potholes. As a result additional timber support and/or pillars are installed to cater for these conditions.

2.5.1.4 UG2 Reef

The UG2 is a chromitite layer, which varies in thickness from 0.5 to 1.2 m. The immediate hangingwall consists of pyroxenite, which contains up to three thin chromitite layers known as the Triplets. The contacts between these thin chromitite layers and the surrounding pyroxenite represent distinct parting planes. The distance into the hangingwall above the UG2 of these partings varies from 0.2 to 4 m. These partings affect the potential stability of UG2 gullies and can open forming discrete beams in the hangingwall. Depending on the thickness of the beam, it is either carried with the face, supported using rockbolts or mine poles and/or packs. Sub vertical joints can combine with the Triplets to create blocky ground conditions that may require additional tendon support in gullies.

2.6 Support of stope gullies

2.6.1 Support objectives and design considerations

Choice of gully geometry can only partially address the risks of falls of ground in stope gullies. Support is required to restrain blocks formed by discontinuities. Bakker and Lipinski (1992), recognised that effective support of the stope face is crucial in reducing the incidence of rock related fatalities and injuries. Thus the DME decided to include the codes of practice into the Minerals Act in 1991. They stressed that improving face support, avoiding the removal of temporary supports, or minimising the presence of personnel in this area should be accompanied by careful planning of mining layouts, so as to prevent unplanned hazardous circumstances. With specific reference to the design of access and cleaning way support systems, Bakker and Lipinski (1992) stated that mines must take into account the following factors:

- Cognisance must be taken of the stress-induced damage as a consequence of the mining layout.
- The mining of sidings should be detailed in a code of practice.
- The installation and design of gully support units should take cognisance of the areas of occurrence of rock related incidents deduced from historical records.

Muller and Ortlepp (1970) distinguished three broad functions of support:

- Reduced the rate of energy release e.g. barrier pillars and waste ribs.
- Promote local stability e.g. systematic pack support or hydraulic props.
- Prevent falls of slabs or blocks of ground, e.g. temporary or permanent sticks.

The support of stope gullies is essential for preventing rockburst damage; however due to the complicated nature of the fracturing in gullies certain requirements should be met, such as the spacing between packs across the gully should be kept to a minimum (Gay *et al.*, 1988).

An example of the effect of improved face support is the case of Hartebeesfontein Gold Mine (Arnold *et al.*, 1994). For the four-year period prior to 1991, this mine averaged 274 falls of ground accidents annually. By reducing the distance between the face and permanent support after the blast and improving temporary support requirements, the number of accidents was decreased to an average of about 169 accidents per year in subsequent years.

Stability and support of gullies have been influenced by the following factors (Spearing, 1995):

- geological features (reef width, reef dip, faults, dykes, joints and bedding planes)
- depth below surface
- mining span (mining -induced stresses)
- mining method (advance or follow behind gullies)
- stope layout (Leads and lags)
- rate of stope advance
- blasting practice (burden, spacing, timing and type of explosive)
- gully dimensions (width and height)
- gully-cleaning method (conventional scraper, continuous scraper, or trackless vehicle scoop)

Gully support is included under the latter two items. Roberts (1995) addressed stope gully support in two ways.

- The problem of gully pack stability and foundation stability was investigated by underground monitoring
- The determination of gully hangingwall fallout thickness between the gully packs in order to evaluate the support resistance requirements to prevent rockfalls and the energy absorption requirements in order to reduce rockburst.

The support used at greater depths in a gully should provide a certain amount of lateral constraint to the intensely fractured gully sidewalls, which prevents sidewall failure as a result of load exerted by the gully packs. The hangingwall support used included rockbolts and steel girders. The overall stope geometry and length of lead were also considered important.

The placement of backfill to reduce rockbursts was common in the deeper Witwatersrand mines during the 1920s and 1930s, since it was found that, with respect to rockbursts, filled stopes gave less trouble than those supported by ordinary methods (Watermeyer and Hoffenberg, 1932). Squeich and Gurtunca (1991) further supported this observation with regard to rockburst and rockfalls in stopes with backfill and those without. However it should be noted that this method only works effectively when backfill is kept within 6m of the stope face and good face area support is installed.

With respect to regional support where stabilising pillars have been used there has been a marked reduction in seismicity e.g. Western Deep Levels South Mine (Hobday and Leach, 1992). However the disadvantage was that after a period of 3-4 years seismicity increased and foundation failure of pillars occurred in the back areas. Effective regional support can be achieved by using a combination of stabilising pillars and backfill as used on Tautona, Savuka and Deelkraal (Essrich *et al.*, 1999).

Gullies along pillars and abutments are particularly prone to damage, as these areas can host large seismic events and the gullies are exposed to high stresses over long distances. Gully sidewalls may also be damaged by stress, scraping, poor blasting practice, or may have failed due to the gully packs generating excessively high loads.

In 1993, experimentation's using wide trackless roadways on the VCR on the Western Deep Levels South Mine took place. Leach (1993) provided the following criteria for an ideal support system for 3m wide trackless roadways for the VCR.

- Provision of extensive areal cover
- It should be immediately acting, or pre-tensionable
- Close to the face it should provide a dynamic energy absorption capacity and overall static support resistance
- Must be installed close to the face and should be installed rapidly and be blast proof
- Should be cheap enough to be installed mine-wide if necessary

2.6.2 Support alongside gullies

Special types of support are required along the edges of gullies (or ledged reef drives), that are different to the in-panel support. Gully packs are preferred to other forms of support because the shape constrains sidewall dilation and accommodates sidewall failure without collapse of the pack. They should be installed close to the face together with active support.

The preference for the use of long axis packs along gullies is well reported. At ERPM Smith and Ortlepp (1976) opted to use 1.2m x 0.6m packs as opposed to 0.6 x 0.6m packs along the perimeter of gullies. The longer based pack was found to be

more stable because it accommodated a degree of frittering of the footwall on the updip side of the gully. Timber packs were chosen in preference to concrete sandwich packs to provide a less rigid support and not punch the updip side footwall into the gully.

Smith and Ortlepp (1976) suggested that the inadequacy of gully support in general is compounded by the requirement that it must be able to sustain a considerable degree of compression without shedding load or, equally important, without increasing load to the point where foundation failure occurs. As a result of increased stress and fracturing it is important to reinforce the foundations on which the support stands.

Gay *et al.* (1988) reported that for the anticipated high closure rates, solid timber packs are generally suitable since they do not generate high forces, which can cause damage to the gully shoulders. An ideal pack for gullies would have a high initial stiffness with a constant yield force of approximately 2000 kN if used at the standard 2m skin to skin spacing. To control damage to gully shoulders, they recommended that the packs should be elongated at right angles to the gully axes. The improved gully conditions in backfilled stopes can be ascribed to the fact that the fill supports all face parallel slabs crossing the gully.

The requirements for gully edge support was re-examined during the 1990's SIMRAC (1995). Squelch and Roberts (1995) indicated that in some mines the stability of gully sidewalls beneath gully packs was a serious problem. Then-current gully pack support systems were prone to sidewall failure, which renders the packs ineffective as support units.

Squelch *et al.* (1995) used numerical modelling to study the response of the gully sidewall to gully pack loading, which they compared to the measured responses. Acceptable results were obtained considering the restrictions and limitations of taking 3D geometry into the 2D models, which were used. An estimation of the reduction in sidewall deformation that can be expected from using the yielding pack had also been obtained. Numerical modelling will also be used to investigate gully hangingwall stability and the interaction with support units (Squelch AP, 1995).

Squelch's (1995) modelling provided the following information:

- The design for a gully specific yielding packs to reduce gully sidewall damage.

- Gully hangingwall support resistance requirement.
- A support system for the gully hangingwall between the line of packs.

Subsequently Squelch and Roberts (1995) conducted investigations to determine the force at which gully sidewall damage begins. The gullies were monitored on the VCR, Vaal Reef and Carbon Leader Reef and both static and dynamic laboratory tests were conducted to examine pack-loading behaviour. In general, the project was aimed at deeper level mining. It was found that gully sidewall movement occurred beneath packs at loads in the range 1500-2000 kN. The dynamic tests showed that timber packs can potentially damage gully sidewalls if used in rockburst prone areas, and are detrimental to gully stability. An optimal maximum load of 1000 kN was proposed, with tolerable limits for idealised pack performance, under both static and dynamic loading conditions, as shown in Figure 2.19.

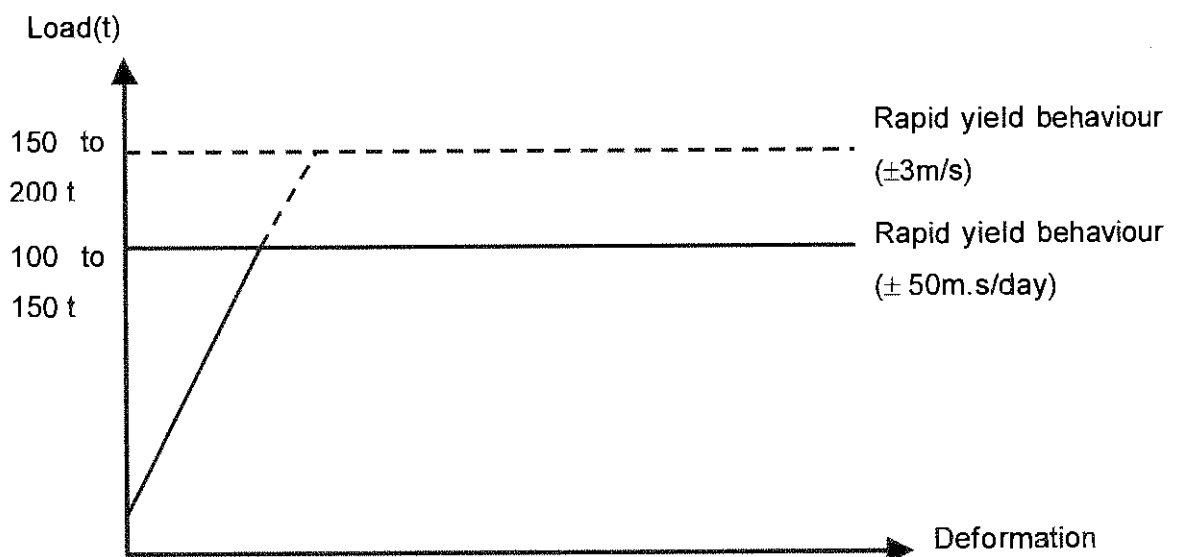

Figure 2.19 - Ideal gully pack performance. (after Roberts, 1995 and Spearing, 1995)

Roberts concluded that gully shoulder collapse occurs when the shoulder support generates a low reactive force after installation and a high reactive force in the back areas. Gully shoulder support in shallow mines include elongate pack supports, grout-based packs, cluster sticks, sticks or elongates. In deep mines solid axis matpacks are used. Prestressed elongates are not recommended as gully edge support in deep mining (Cook, Lewis and Pienaar, 1994).

Using Roberts' criteria as a basis for design, Brown and Noble (1994), and Noble (1995) reported on initial results of a gully support system designed to yield at 1500 kN, at ERPM at 2300 m depth, where Energy Release Rate was 20 MJ/m², and quartzite hangingwall and footwall. Yield occurred at 1100 kN, and resulted from the fact that the fractured gully sidewall forming, the pack foundation, was displaced into the gully. The packs tested were installed adjacent to a deep footwall lifted dip gully with fracturing was parallel to gully sidewalls, gully sidewall closure ranged from 260-170mm, with no marked deterioration of the footwall beneath the packs. Yielding support units on updip sidewalls of strike gullies should add to the stability of the gully systems where necessary (Adams *et al.*, 1999). Another factor that is important at great depth is areal support across gully span.

Recently published papers showing mining layouts for deep mines indicate a preference for long axis packs on the updip sides of gullies, with either square or long axis packs on the downdip side. For example, Murphy and Brenchley (1999) show 2.2 by 0.75 m packs in use at Tautona mine on the Carbon Leader Reef.

Rockburst resistant support must be installed in some deep gullies, especially when traversing faults and dykes. The use of softer support on gully edges (e.g. soft packs, or bringing backfill down to the gully edge with gaps left for storage) is encouraged. The integration of elongates with packs on gullies appear to show improved performance when compared to current standards. The idea of using elongates with special headboards to allow lagging across gullies also looks promising. The gully heading should be supported with rockburst-resistant support (such as rapid yielding hydraulic props with headboards) installed in the face area (Durrheim *et al.*, 1998).

2.6.3 Gully hangingwall and sidewall support

Hangingwall and sidewalls of gullies sometimes have rock reinforcement tendons, which provide active support. Installation of these should be perpendicular to the fracture and bedding planes, thus increasing the friction between blocks and the enhancing capability of the rock surrounding gullies to be self supported. The cutting of slots in the footwall adjacent and parallel to the gully can hinder movement of the sidewalls of centre gullies and dip gullies (Noble, 1995).

An alternative suggested by Gay *et al.* (1988) was the installation of skeleton packs between the standard gully packs which are commonly spaced 2m apart could prevent the fall out of face parallel beams across gullies. This is a common failure of gullies that are aggravated by the presence of strike orientated geological structures.

Roberts (1995) proposed the following support pressures required from tendons based on the reported heights of rockfalls between gully packs on three different reefs. The data was obtained from all accidents for the period 1990 to 1992, and typical maximum thickness of falls (95% of occurrences) and required support resistance across gullies is shown in Table 2.1.

Provision should be made for areal support across the gully span if it is required and, according to Adams *et al.*, (1999), this should be a standard in seismically active places. This support may be yielding support that reinforces the rock against rockburst damage or more passive support which bridges between gully support members where rockfalls are anticipated.

Table 2.1 – Tendon support requirements to restrain falls over gullies (after Roberts, 1995)

Reef	Fall thickness (m)	Support Resistance (kN/m ²)	Energy absorption capacity (kJ/m ²)	Required hwall support (Yielding Tendons /m ²)
Vaal Reef	0.55	15	8	0.8
VCR	0.7	19	10	1
CLR	1	26	15	1.5

Depending on the condition, mechanical rockbolts that include grouted rebar, truss bolts, cones bolts or lacing and meshing, are used on the gully hangingwall. Rockbolting of the hangingwall has been used by a number of mines with some success. An even more effective method would be to link the tendons with either steel rope lacing or steel straps to prevent hangingwall fallout between the tendons (Noble, 1995). Provided that the drilling of suitably oriented holes into the fractured hangingwall is not too difficult, this type of gully support has great potential for reducing rockfalls.

Where ground conditions are particularly weak or falls occur, the application of decking (or the use of sets and cribbing) has been recommended since the early 1970's (Cook *et al.*, 1972). Loops of old scraper rope are built into the packs, against the hangingwall, when packs are constructed ahead of the gully. If the hangingwall of the gully deteriorates at any stage, as is shown in Figure 2.20, steel joists (2m X 15cm X 7cm) can be installed into the loops and locked in position by means of steel pins. The spans between the steel joists are thereafter decked with 2.4m long round lagging.

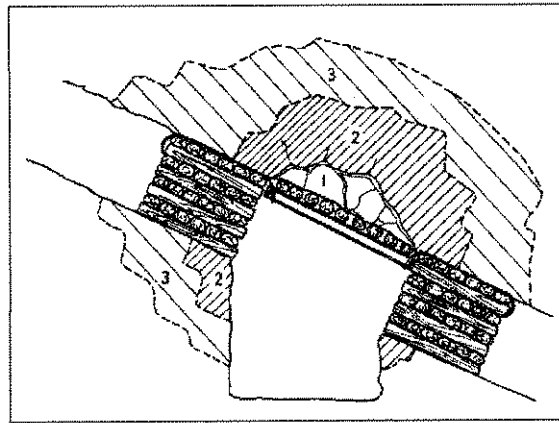

Figure 2.20 - A section through a gully indicating the three main stages of deterioration. Decking to keep the hanging in place not only provides safety but inhibits the second and third stages of deterioration in the hanging and footwall (after Cook *et al.*, 1972)

2.7 Generalised published guidelines for stope gullies

Very few overall guidelines have been published for gully practices. Adams *et al.*, (1999) have put together a design methodology for stable gully support which included the following points:

- Layout the gully on a plan with geology included on it.
- Ensure correct position and alignment of gullies by the provision and extension of survey lines.
- Use paint lines underground to ensure that gully is straight, where geological conditions allow.
- Footwall lift the gully as a secondary operation once the prestressed gully packs are installed.

- Create sufficient gully depth for travelling and storage without making sidewalls unnecessarily high.
- Optimise the number of blast holes and explosives used to advance the gully.
- Support the gully hangingwall, extending such support between the gully edge supports, with rock reinforcing and an areal surface support.
- Evaluate the geotechnical characteristics of the gully sidewalls and consider the need for support of the gully sidewalls with rock reinforcing and aerial surface support.
- Choose a gully edge support with long-term stability, which also offers a relatively stiff performance initially but will not transmit excessive loads into the footwall and hangingwall.
- If the area is likely to be seismically active select support units, which will perform satisfactorily, under dynamic loading conditions.

Past guidelines on strike gullies focus on stress and blasting practice related problems, with most attention on deeper level mines. Most publications since the 1970's have provided similar information. Typically the identified problem areas include (COMRO, 1988):

- Poor blasting practice (too few holes and over-charging) causes damage to sidewalls and hangingwall.
- Long advance headings lead to adverse stress fracture geometries, coupled with which is a recognition that fracture patterns can be manipulated with sidings, or other changes to excavation geometry (Budavari, 1983).
- Gully shoulder damage requires the use of long axis packs that are not unduly strong, to prevent collapse of the shoulders, consequential collapse of the pack, and loss of hangingwall support (Roberts, 1995). Until recently, solid mat packs were preferred. Now, engineered designs with near constant 1000 kN yield loads are recommended.
- Gully conditions in deeper, more highly stressed, mining environments are improved where gullies are footwall lifted behind the stope face.
- Spans between support on opposite sides of gullies must be minimised, in particular in the area where the gully meets the bottom of a panel face, and provision must be made for additional hangingwall support, typically in the form of bolting, or timber/steel capping and cribbing.

Where the risk of rockburst damage is high, Durrheim *et al.*, 1998, recommend the following practices should be adopted for gully support.

- Use of foam cement in the south siding alongside and behind the packs to absorb the impact of the dilating rock and to maintain the integrity of the hangingwall rocks.
- Use of yield tendons together with some form of areal support to pin the gully hangingwall. This type of support is more capable of accommodating shear along weak planes parallel to the hangingwall. Angle this support to be at right angles to the dominant fracturing.
- Get backfill closer to the gully edge. Prevent backfill from dilating into the gully by using mesh between packs.
- Precondition the pillar edges by drilling and blasting from the heading. This will create a buffer zone and ensure that the shear zone, resulting from foundation failure, is that much more distant from the pillar edge.
- The gully siding should be deep enough so that the pillar edge and the packs on the downdip side are separated by at least a metre. These will reduce the likelihood of buckling due to violent dilation of rock from the pillar edge. Use of foam cement to maintain the integrity of the hangingwall in this area.

For deep Carbon Leader mines, with high stress and rockburst conditions, van Eck (1997) lists the following as pre-requisites for successful gully support.

- Reduce the span across the gully, measured from backfill to backfill, to increase the stability of the span over the gully. The objective is to keep the support resistance and energy absorption of the support system as even as possible across panel and gully.
- Reduce energy transfer to the gully shoulders to reduce gully shoulder failure in the back areas due to time dependent closure or dynamic loading.
- Increase areal cover of the gully hangingwall.

Despite recognition of problems, most documented cases show that while mines are prepared to use sidings, and other expensive, or laborious practices, the gully is invariably advanced as a heading with sidings cut some distance back. A clear trade-off has been (and still is) applied, between optimising induced fracture geometry, and making mining operations as less onerous as possible.

2.8 Safety in gullies

The previous sections indicate that gully related problems have long been recognised and practices to improve conditions have been devised, and in many instances proven. A brief review of safety statistics and causes of accidents provides some measure of the implementation of safe practices, and helps to identify gaps in existing guidelines.

Investigations by Stewart *et al.* (1995) have indicated that rockfalls and rockbursts account for more than a quarter of the total injuries in the mining industry and more than half of all fatalities, a significant proportion of which being related to gullies. Gay *et al.* (1988) indicated that most accidents in stopes occur within 10m of the stope face and in the gullies which provide access to the working area. From a safety point of view these are the two most important areas on a mine because of the difficulty in providing support close to the face and the relatively high density of personnel in these areas.

A review of some of the published figures for proportions of fatalities associated with gullies is given in Table 2.2. While considerable improvements in gully stability would appear to be apparent between the mid-1970 and mid-1980's, there does not appear to be a continuing recent improving trend. With the exception of Wagner and Tainton (1976), who only drew data from mines in the West Rand and Far West Rand areas, the other sources are industry wide. Wagner and Tainton (1976) attributed high gully accident rates primarily to inadequate gully support systems, in areas of long leads or adjacent to strike abutments.

Based on figures presented by Roberts and Jager (1992), and Jager and Ryder (1999), very different proportions of accidents are gully related in different mining regions. These are summarised in Table 2.3. Given the higher accident rate, there appears to be disproportionately few gully accidents in the deep West Rand mines. A conclusion based on Roberts and Jager's observations would be that this is probably the result of using unsuitable gully layout geometries under moderately stressed conditions.

Table 2.2 - Proportion of industry-wide rock related fatalities that are gully related

<i>Time period</i>	<i>Total rock related fatalities in gullies</i>	<i>Rockburst related</i>	<i>Rockfall related</i>	<i>Data source</i>
1971-1975	56%	-	-	Wagner and Tainton, 1976
1985-1986	6.5%	5%	7%	Gay et al. 1988
1990	17%	-	-	Roberts and Jager, 1992
1991-1992	14.2%	-	-	Roberts, 1995
1990-1997	14.6%	8.4%	6.2%	Jager and Ryder, 1999

Table 2.3 - Comparison of gully accidents in different mining districts

<i>Mining district</i>	<i>Total number of rock related fatalities per million square metres mined</i>	<i>Proportion of rock related fatalities in gullies</i>
<i>Free State</i>	9.65	27%
<i>Klerksdorp</i>	14.65	23%
<i>Far West Rand</i>	22.15	5%

According to Roberts and Jager (1992) three out of five stope gully fatalities occurred either at a winch chamber or at the intersection of strike and dip gullies in the Far West Rand. However as a result of the high level of seismicity the gullies would have been adequately supported. In contrast to the Far West Rand the Orange Free State and Klerksdorp regions had 16 of the 18 gully fatalities due to rockfalls and four of the eight fatal accidents occurred at the gully intersections respectively. Roberts and Jager (1992) indicated that the correct cutting of gully sidings was often neglected in the various regions.

Another cause of the gully accidents was the method of siding excavation. In some cases where the gully siding had been lagging, in order to catch up with the face a long strike length of the gully was drilled downdip and then blasted to create the siding. This resulted in a large unsupported span being created. It was also noted that in the Orange Free State rock-bolting in gullies could reduce falls of ground and

in the Klerksdorp region there are indications that the shepherd crook grouted rebar support is effective for rockfall control and less effective in controlling rockburst damage (Roberts and Jager, 1992).

The following are reported by Spearing (1995) as the most hazardous areas in gullies:

- the intersection between the gully and the stope face because the installation of adequate support is difficult owing to face cleaning (pulling out of support by the scraper) and blast damage
- boxhole intersections because the unsupported span is relatively large and the height of the gully in such areas is greater
- Winch beds adjacent to the gully where the span is larger than elsewhere in the gully.

COMRO in 1991 analysed the causes and circumstances of rock-related fatalities where they attempted to determine the following.

- The location of the fatality
- Whether the accident was a result of a rockfall or rockburst
- The effectiveness of support standards
- Degree of adherence to mine standards
- Possibility that mining geometry was a contributory cause
- Location of problem areas in stopes and tunnels

The following points were noted from this study, with reference to stope gullies.

At shallow depths yield pillars are commonly orientated on strike below the strike gullies. In stoping widths up to 2m the area between these pillars is adequately supported by yielding timber props.

Geological structures are the main cause of local falls of ground in shallow stopes. They form blocks of rock of various shapes and sizes, and depending on their geometries, the blocks can be either stable or potentially unstable. The lack of a significant fracture zone which would cause horizontal dilation ahead of the stope face means that little or no horizontal compressive stresses are developed in the

stope hangingwall and footwall, to clamp the blocks of rock together (Gay *et al.*, 1988).

In intermediate to deep mines, the area extending 6m from the gully in an updip direction to a position between the face and the first row of support is particularly vulnerable to falls of ground. Similarly, Wagner and Tainton (1978) found that up to 20 percent of all stope accidents occur in this area. The reasons are first, the area, being adjacent to the face, has a low support density and large unsupported spans on dip, and second, there is a complex pattern of fracturing.

Bedding plays a major role in falls of ground, especially if partings with poor cohesion separate the strata. Faults and joints define other discontinuities from which blocks of rock may fall. Studies of the geometry of falls in gold mines show that most falls vary in area from 2m²-5m² and that the form of the initial fall is that of an acute triangular prism bounded by planes dipping at 25° – 70° (Gay *et al.*, 1988)

The general conclusion that was reached was the face directly in front of the follow behind gully, where a large number of fatalities occurred, was frequently poorly supported and, in some case, it was found that the support did not extend beyond the line of the downdip gully packs. However, permanent support seemed to be working well as it was found that few fatalities occurred between the permanent support or in the stope gullies.

2.9 Conclusions drawn from published literature

On the basis of the literature survey carried out it is clear that many of the primary causes of gully problems have probably been recognised for some 70 years. It is also clear that corrective action is largely unpopular, and has been repeatedly ignored, as it makes practical mining operations more complex.

Although the literature is extensive and informative, it fails to show when one ought to change from one mining layout to the next as depth is increased. It also fails to clearly define the ranges in depth from shallow to deep mining.

An omission in the literature is any comprehensive assessment of different gully requirements arising from differences in local geology on various reefs. There has

been some limited-scope assessments, for example, Simrac-GAP 032 (1995), derived different support pressure requirements for deep mining VCR, Carbon Leader and Vaal Reefs, based on fall of ground thickness. Another example is a comparison of fracture patterns around wide headings on the Carbon Leader at Western Deep Levels and the Main Reef Leader at ERPM (Turner, 1987), which shows considerable influence of local geology, where the difference is between massive quartzite, and a narrow quartzite middling with shale above. It would however be difficult in most cases to derive a specific, dimensioned, gully geometry or support recommendation for a particular reef at a selected depth from only the available documented cases, or past guidelines.

CHAPTER 3 - DATA GATHERING TO ASSESS CURRENT INDUSTRY PRACTICE

3.1 Introduction

A range of potential best practices is broadly indicated in the literature. Taking these as a base, it was considered essential to examine current industry practices as a means of gauging successful and poor operational methods, together with the existing level of compliance to, and opinions of, theoretically better gully practices.

Various mines, both gold and platinum (operating on a range of different depths and reef horizons) were visited with the object of acquiring data to first assess current gully practices, second to gather data which could be used to calibrate numerical models for evaluating best practice mining methods. The study covered 43 Platinum gullies and 64 gold gullies, giving an overall total of 107 gullies. The gullies examined on the platinum mines included the following reef types; UG2, Pothole Merensky Reef and Normal Merensky Reef. In the gold mines, the Basal Reef, Carbon Leader, Ventersdorp Contact Reef, Vaal Reef, Kalkoenskrans Reef, Beatrix Reef, and Kimberley Reefs were investigated.

3.2 Format of data gathered from mines

When visiting mines, data was gathered to provide information in three broad areas. The first consideration is the gully design and layout procedure applied by each mine (i.e. the design issues, based on standards and Codes of Practice). Secondly, the success in maintaining safe gully conditions underground was assessed based on underground visits; and thirdly the opinions of mine personnel relating to desirable gully practices were obtained using a questionnaire.

To examine the planned gully layout and support practices on each of the mines, the following data was gathered:

1. Mine standard drawings showing gully layouts and support and any variations thereof.
2. Sections relating to gullies in the Mine Code of Practice

3. Reef mined – stope width
4. Depth of mining
5. Mining method (scattered, sequential grid, longwall, up-dip, etc.)
6. Hangingwall, footwall strata and strengths
7. Types of gully support in use

From underground visits the following data was assembled for each gully inspected:

1. Gully name
2. Gully depth below surface
3. Gully geometry (wide heading, ledging, advance strike gully, footwall lifted, etc.)
4. Gully side support (pack type, props, etc.) and size and spacing
5. Gully hangingwall support (no support, bolted, trussed, etc.) and spacing
6. Height of gully (both in gully and in ledges or stopes on either side)
7. Width of gully (and comparison to original, or standard, width)
8. Condition of hangingwall over gully Condition of sidewall beneath packs
9. Any relevant photographs along gully showing general conditions and support
10. Local mining geometry (e.g. normal mining area, remnant or other highly stressed area, etc.)
11. Energy Release Rate(ERR) value for adjacent mining faces
12. Comments on any particular circumstances which may adversely affect gully conditions observed

In addition to the general data gathered and underground visits, a number of mine-based gully workshops were attended. A questionnaire was formulated (in the platinum mines by D. Spencer and gold mines by Ms K. Naidoo) and distributed to the mine personnel for feedback. The questions asked are as follows:

1. What do you perceive as a siding?
2. What is the role/purpose of a siding?
3. What is your opinion on stable gully spans?
4. What is your opinion on effective gully support?
5. What is your opinion of gully stability in seismic versus non seismic areas.
6. What are the definitions of best practice for gully geometry.
7. How would you minimise fall of ground hazards in gullies.

3.3 Summary of mining areas visited

A large range of mines formed part of the research study, based on their reef type and depth. The mines examined in the Bushveld region, included Amandelbult, Karee, Impala Platinum and Northam. The Witwatersrand Supergroup encompasses a much wider area, and as such a greater number of gold mines were visited, which included Savuka, Mponeng, Tau Tona, Elandsrand, Deelkraal, West Driefontein, Kloof, Durban Deep, and Placer Dome Western Areas South Deep in Gauteng. In the Klerksdorp area, Tau Lekoa, Kopanang and Hartebeesfontein were visited while data was collected at Bambanani, Beatrix, St Helena, and Oryx in the Free State. These mines provided data to permit a broad - based analysis to be performed on all gully types. A summary of the data sources, on the basis of reef and depth is shown in Table 3.1. The list covers most significant mines in the industry extending over a full range of geological conditions and mining depth.

Table 3.1 - Number of gullies visited as a function of reef type and mining depth.

Reef Type	No of gullies visited	Depths																	
		PLATINUM REEFS																	
Merensky Reef	35	590	600	650	660	880						1800	2000						
UG2 Reef	7				670														
		GOLD REEFS																	
Beatrix Reef	4					900													
Basal Reef	10								1656					2500	2800				
Carbon Leader Reef	19											2000	2100			2701			2905
Ventersdorp Contact Reef	24							1100	1200			2000	2100		2500			2862	3400
Vaal Reef	7								1200					2300					
Kalkoenskrans Reef	4											1850							
Kimberley Reef	4					900													

At each mine a number of gullies were inspected, comparing where possible the reaction to the geotechnical environment when different gully layouts are used. A summary of the geological characteristics observed on each reef horizon is listed in Table 3.2.

Table 3.2 - Summary of hangingwall and footwall characteristics for various reefs.

Reef Types & dip	Hangingwall (hw) & UCS	Footwall (fw) & UCS	Locality
PLATINUM REEFS			
UG 2 (20 deg)	Olivine bearing Pyroxenite (130 MPa)	Pegmatoidal Pyroxenite (130 MPa)	Bushveld, Rustenberg; Kroondal
Merensky Reef (20deg)	Mottled Anorthosite (190-200 MPa)	Spotted Anorthosite (220 MPa)	Bushveld, Rustenberg,
(10-12 deg)	Pyroxenite hangingwall with local dome	Spotted Anorthositic norite footwall (230 MPa)	Thabazimbi
GOLD REEFS			
Beatrix Reef (15 deg)	Strong Quartzite (220-240 MPa)	Weak Quartzite (120 MPa)	Witwatersrand, Welkom
Basal Reef (30-35deg)	Waxy Brown Leader Quartzite (180 MPa) Khaki shale (65 MPa)	UF 2 Quartzite (220 MPa)	Witwatersrand, Welkom
Carbon Leader (21deg)	Green Bar Shale above (160 MPa) Quartzite (215 MPa)	Quartzite (220 MPa)	Witwatersrand, Carletonville
Ventersdorp Contact Reef (25deg)	Siliceous Quartzitic unit (200 MPa) Ventersdorp Lavas (315 MPa)	Kimberley Quartzite (200MPa) Elsburg Quartzites (25 MPa)	Witwatersrand, West Rand- Klerksdorp, Carletonville
Vaal Reef (17deg)	Quartzite (190 MPa)	Quartzite (180 MPa)	Witwatersrand, Klerksdorp
B Reef	Incompetent well bedded argillaceous Quartzite (90-200 MPa)	Quartzite (26-139 MPa)	Witwatersrand, Welkom
Kimberley Reef (80deg)	Quartzite (200-250 MPa)	Quartzite (200-250 MPa)	Witwatersrand, Welkom, Randfontein

3.4 Industry opinions on gully issues

This section examines the opinions of mine-based personnel, both rock engineering and production, on issues relating to gullies. As noted in section 3.2, the source of these opinions is a questionnaire, discussions with mine staff, and attendance of mine workshops at which gully issues were discussed. The workshops were at the mine's own initiative, reflecting their concern over gully conditions and a drive in terms of "zero tolerance" of poor underground standards. On the deep mines an important issue was time dependent gully deterioration where long gullies have to be maintained over extensive periods of time.

In general it was found that industry opinions on gully design and support requirements are often contradictory. In particular there were often differing opinions between rock engineers and mining personnel. The following is a summary of these views and do not necessarily reflect the opinions of the author. The list covers all responses to what the mining personnel perceived to be concerns and best practices for gullies.

3.4.1 Purpose of a gully

Gullies are generally considered to be required to remove broken rock from stopes and to provide accessways for men and material to enter stopes. Gullies provide pathways for all services required in stopes, including the following:

- inch air column (suspended from packs or hangingwall)
- Electricity cables (suspended from packs or hangingwall)
- Backfill range (suspended from packs or hangingwall)
- Mono Winch (suspended from hangingwall)
- Bell Wire (on packs)
- Blasting Cables (on packs)
- Scraper (on footwall)

In general mines use pigtail eyebolts and S-hooks and sling eyebolts to suspend pipes, etc. close to hangingwall.

3.4.2 Key issues for maintenance of safe gullies

Gullies were recognised as a critical safety area on all the deep, higher stressed, mines in particular. The following issues were considered to strongly influence the creation and maintenance of stable, safe and effective gullies.

- Drilling and blasting +marking
- Gully depth
- Direction /Line—siting
- Sidings
- Span across gullies
- Gully Support
- Lead and lags between adjacent stope panels
- Back area strategy (e.g. when do gullies get rehabilitated or sealed off in a longwall environment)
- Accountability and attitude of mining personnel to safe practices
- Drainage of mine water via gullies
- Local geology

Factors to address to specifically minimise falls of ground in gullies are generally considered to include the following:

- Proper blasting in terms of type, burden, marking and drilling
- Timely installation of support.
- Installation of temporary support whilst drilling.
- Prevent blast damage to the gully shoulders.
- Gullies should be straight to avoid pulling out support.
- Selection of correct gully geometry to minimise stress damage to gully shoulders and hangingwall

3.5 Gully layout and geometry issues

On shallow mines the main design issue relates to when a siding is needed, and what constitutes an adequate siding. On gold mines, and where depth and stress are greater, the issues relate to when it becomes essential to attempt to modify stress fracture patterns.

3.5.1 What are the preferred gully layouts

When mining with an underhand layout mining people or miners almost unanimously prefer a narrow ASG without a downdip siding if they can get away with it. A siding, if really needed, would be carried on the down dip side of the gully some distance back from the face. The preference for this is that the heading provides a free breaking point for the stope blast and advance of heading, ASG and siding can all be carried out as independent activities.

Sidings are considered a necessary nuisance because they have to be cleaned by hand. Wide headings are really only well accepted on the deeper mines where other layouts have been proven to give intolerable conditions.

Overhand mining layouts, where only one gully at the bottom of the raiseline or longwall needs to be advanced and the other gullies are footwall lifted within panels are favoured for deep mining conditions. Gully conditions are generally acceptable and from the mining point of view there is some flexibility in terms of gully advance as, while the gully needs to be lifted past the lagging panel face, it is generally considered only as a top escapeway for the leading panel. As such it is often

advanced erratically. Some mines aim for 5 m from the face but only achieve 7 m or more in practice.

3.5.2 What constitutes a siding?

Sidings on gold mines were perceived to be an on - reef cut with a dimension generally not less than 1 to 2 metres. In general it is accepted that the width of the cut should be such that decent support (such as a pack) can be installed with a space left behind it for bulking of the rock mass.

On some of the platinum mines where depth is less than 400 metres below surface, a variation in opinion states that a siding is any excavation over and above the dimensions of the gully. This may include a “shaped” excavation to remove the ground that would become loose due to stress induced fracturing. This includes a 0.5 m on reef cut to move a pillar slightly away from the gully and possibly marginally improve its stability.

Most mines are undecided as to an optimum siding width, and while accepting that probably wider is better, want to keep to an absolute minimum due to cleaning difficulties when mining down dip of the gully. To ease this cleaning problem, some mines are prepared to tolerate an off reef siding that is cut horizontal out from the gully. They recognise that this can be detrimental to hangingwall stability, particularly when mining reefs such as the Carbon Leader, where there is weak shale a short distance into the hangingwall.

3.5.3 Why should a siding be created?

The role of sidings in both gold and platinum mines were generally considered, or understood, to be the following:

- To move any stress fracture zone away from the edge of the gully.
- To maintain the width to height ratio of the pillar in the case of shallow mining layouts using crush pillars.
- To be able to install support on both sides of the gully.
- To reduce the height of the fracture zone which tends to curve over the gully.

- To prevent shearing of the gully hangingwall adjacent to solid (including along the edge of a crush pillar).

Uncertainties with regard to sidings in the platinum mines relate to:

- The level of hazard represented by unsupported slabs which form along pillars adjacent to gullies where no siding is used
- Is this situation more hazardous in areas that experience seismicity as opposed to those areas that do not?
- Is there evidence suggesting that fall of ground accidents occur more frequently at depth where “proper” sidings are not cut?
- Is the tendency of slipping out a 0.5 metre siding acceptable?

3.5.4 Where should a siding be cut?

On mines such as the moderately deep platinum mines, or those gold mines where stress fracturing is apparent, but not severe, the following divergent opinions were expressed with respect to sidings:

1. Sidings should be cut in line with the gully face.
2. Sidings should be cut somewhere between the gully heading and the panel face. If the siding is allowed to lag behind the panel face, the siding blast damages the support on the up dip side of the gully.
3. Siding should lag a maximum of 3 metres behind the stope face. Advantages are as follows :
 - The face is blasted against a solid siding.
 - The solid siding minimises the span across the gully in the immediate face area.
 - Yield pillars (in shallower mines) only commence fracturing some 20 to 30 metres behind the face, therefore gully parallel fracturing is not an issue.

These opinions are all indicative of an environment where leanings towards ease of carrying out mining tasks outweigh the risks that can result from developing poor ground conditions.

On one mine it was commented that even if the management (down to shiftboss) want sidings, it is difficult to get them cut in practice. This deep mine had opted to

use a mix of long (1.5 m) and short (0.75 m) packs along gullies with the larger packs on the down dip side as a means of forcing sufficiently large sidings to be cut to allow installation of the packs.

3.5.5 At what mining depth is a siding required?

Opinion is that for depths down to around 500 metres below surface sidings need not be carried. However this needs to be qualified with respect to the following:

- Rock strengths of the reef as well as the hangingwall and footwall.
- Percentage extraction.
- Whether rigid or yielding pillars are used

Below 500 metres below surface, stress induced fracturing of gully sidewalls does occur in platinum mines and occasionally in gold mines. If rigid pillars are used with no siding some form of tendon support is favoured to contain the sidewall slabs created by stress induced fracturing. Where yielding pillars are used, then a siding is cut. The depth of this siding does not always conform to the preferred standard of between 1 and 2 metres.

Most gold mines are deeper than 1000 m, and they all accept that some form of siding is necessary. The only exceptions are the few mines where the dip exceeds 30 degrees, and where it is believed that sidings are impractical at dips in excess of 30 degrees.

3.5.6 Hangingwall profile and gully depth?

The gully hangingwall profile should be cut along bedding, parallel to the dip of the strata. In other words do not create a brow, or break into the strata above reef. To assist with the above point, gullies should have a maximum height of 2.5 metres. Any higher and the top holes will tend to be drilled into the hangingwall.

3.5.7 How big should a gully be?

Many mines were of the opinion that gully width and height should be minimised to ensure the gully is cleaned and not used as a storage area. As one limit, Regulation

6.1 of the Minerals Act states that gullies must be a minimum of 1.8m high to provide a travelling way. Opinions on gully depth included:

- Gullies should be cut shallow if possible to cut down on waste tonnage, and that 1.8 m depth should be considered a maximum.
- On one mine top of panel escapeway gully sizes were originally based on a 9m² cross section for ventilation needs.
- For rescue operations gullies need to be deep and clean and advance close to the face (when footwall lifted).
- Another consideration is that the depth should be based on the height required to drill holes and install support, e.g. a 1.2m split set. Need 2.1m for a normal air leg and machine if the hole is to be vertical (alternative equipment is needed to drill a vertical hole in a shallower gully).
- Consensus was that the hangingwall to footwall distance must be a minimum of 1.8m, as per the regulations.

In general the controlling factors for size are the width of scraper (or other cleaning equipment such as an LHD), stope closure on deep mines, and the space required for services, such as water, air and backfill columns. As an example a scraper may be 1.1m and approximately 30 cm minimum is allowed for clearance to give a minimum gully width of 1.4 m.

Confusion arises on certain mines when there are different standard sizes for different reefs and the consensus was that each mine should have one dimension for all gullies, one set of standards only, rather than different dimensions for strike gullies, dip gullies, different reefs, waterways, material ways, etc.

Favoured dimensions for scraper cleaning gullies were of the order of 1.6m wide by 1.8m deep in the deeper mines. Shallower mines opted to go wider at 2 m width. In both cases an extra 20 cm or more was considered tolerable for the distance between supports across gullies.

Many mines accepted that it was impossible to maintain gullies within the standard dimensions for the entire gully life. Time dependent deterioration would ensure that widths increase and final gully dimensions would be larger than the standards, which reflected the dimensions to be cut at the face.

3.5.8 What is a stable span across a gully?

The opinion on stable gully spans seemed to encompass the following variables such as depth, geology, mining geometry and ground conditions. It is also different for different reefs and regions. Most replied that limiting stable spans were of the order of 2.5 to 3 metres, even at shallow depth. One reply from a platinum mine stated that under his mines normal conditions an unsupported span of 5 metres would stand in 5 percent of the cases.

It is generally recognised that whatever gully size is created at the face, it will deteriorate resulting in an increase in gully width back from face. Increased spans, and potentially unstable conditions arise where support is snagged by the scraper and falls out, gully walls collapse and support is lost, seismicity ejects packs from sidings, at tipping points into orepasses, and at winch or water jet cubbies. Either additional support needs to be planned (e.g. at cubbies) or remedial work is required.

3.5.9 What needs to be done to keep a gully straight?

It was recognised that gullies need to be kept straight, in particular when scraper cleaning is used, otherwise damage to gully shoulder and support occurs and large spans result. The implications of off - line gullies that change direction are support dislodgement, additional hangingwall support, accumulation of broken rock, water accumulation, rope and scraper wear, and changed development layouts. If a gully is off-line it may have to be swung back to get to a planned boxhole position in certain layouts. It was generally felt that a single bend could be tolerated, provided the gully swing is no more than 5 degrees. Incorrect placement of rigging holes for scrapers can also account for much sidewall and pack damage.

To ensure gullies remain straight, provision of timeous and correct gully direction lines is the key issue. Pegs tend to get lost through minor falls of ground and then miners take lines ineffectively. Clear marking and coloration of gully and pack lines using fluorescent paint is advisable. The responsibility for lines must remain with the team leader and miner. It was commented that in many mines only a gully centreline was painted on the hangingwall.

3.5.10 What influence does panel lead have on gullies?

Leads and lags between stope panels are considered a concern wherever stress levels are high enough to initiate stress fracturing. As gullies tend to run adjacent to any long leads which form (either up or down dip), long leads are recognised as being detrimental to gully conditions.

In the very deep mines where these conditions are most severe, excessive lead /lags are considered to be anything in excess of 10 to 20 m. On certain mines it is accepted that leads in some areas have become unduly long and consideration is given to formulating a support requirement versus lead/lag matrix.

In an overhand layout, where gullies act as cleaning ways for the panel above, and an escape way for the panel below, there is a tendency to only lift the gully just past the face of the lagging panel. Most people recognise that it should be brought to within 5 m of this face. It was admitted that the five-metre criterion was met in only ten percent of the cases, with most gullies lagging seven to eight metres behind the face. On most mines the upper panel is responsible for this gully, not the panel whose escape gully it is. Possibly this responsibility should change to improve access and safety.

An optimal lead / lag on panels is thought of as 10m with gullies 2m ahead of panel faces for cleaning. In an over hand layout this would give an 8 m distance from the top escape gully to the leading panel face. Poor conditions tend to arise at the panel face/gully intersection where high stress conditions exist. This area is recognised as being particularly hazardous and must be supported. Long leads, say 40 m, contribute to severe deterioration in the face - gully area.

3.5.11 How big should a wide heading be?

Opinion here varied considerably ranging from 5 m wide to a short panel (15m- 20m). In essence it came down to the favoured size of pack, plus a bulking space, plus gully width. A minimum advance distance was around 4 m (lifted gully 2 m ahead of main panel face, plus the ledge ahead of the gully). Some mines considered it preferential to advance further ahead permitting early detection of faults and structure. This worsens the hangingwall state at the toe of the panel.

3.5.12 How is gully serviceability maintained?

Gullies may have to be kept open for long periods of time. Time dependent deterioration starts right away. It becomes noticeable 20m from the face. In some cases mines have to keep gullies up to 150m long operational. Over these long scraper pulls, considerable damage may be done to support and a support monitoring program is required, with replacement of support as required.

In general it was felt, particularly on the deeper mines using longwalling method, that systems of accountability are essential if gully conditions are to be maintained for long periods of time. Gully areas of concern must be identified and persons nominated to be accountable for rectifying poor areas. This would involve the drawing up of implementation schedules, which specify classes of support required. Levels of support would be specified by mine standard for normal support and by rock engineers for rehabilitation or extra support, such as void filling or ground consolidation.

3.6 Gully support issues

3.6.1 What support is required in a gully?

Effective gully support was considered to be dependent on factors such as seismicity and ground conditions as well as the need to match support characteristics to the conditions.

3.6.1.1 Shallow mining conditions

Some respondents felt that tendon support was best, as it was not subject to blast damage or being scraped out. Potential problems encountered were loss of tension with roofbolts and the quality of grouting with regards to rebars.

Pillars were viewed as the most effective gully support on Platinum mines, where either the ground conditions were poor or in a low stress environment together with mine poles, in other words a rigid system. Additional pillars are left along gullies, and sidings omitted when highly jointed or faulted ground is encountered.

One response on a platinum mine suggested that there were three stages of gully support, namely:

- Temporary face support (mechanical prop) and Permanent hangingwall support (tendon).
- Temporary siding support (mechanical prop) and Permanent hangingwall support (tendon).
- Permanent siding (stick or pack) and hangingwall support (tendon).

The hangingwall support will be determined by the fall of ground thickness whereas the expected closure and the fall out size will determine the siding support.

3.6.1.2 Deeper mining conditions

With regard to seismic versus non-seismic areas, different opinions exist on the gold and platinum mines.

The consensus on the platinum mines was that seismicity was not a problem. One response suggests that the following should be used in seismic and non-seismic conditions:

Non seismic:	Hangingwall	-	Tendons.
	Sidings	-	Up dip - packs. Down dip - elongates.
Seismic:	Hangingwall	-	Tendons.
	Sidings	-	Packs on both shoulders.

For site specific areas additional secondary support in the form of mesh and lacing, sets and straps could be used.

By comparison, gold mining personnel found seismicity to be of prime concern in intermediate and deep mines. A repeated concern was the multiplicity of standards on certain mines, for both gully layout and support and many production personnel expressed a need for simplification of standards. Opinions on support densities tended to reflect mine's standards and indicated different support needs at different mining depths.

There was considerable dispute and difference of opinion over preferred gully edge, or shoulder support, even amongst staff on the same mine. Most mining personnel on the deeper mines preferred packs. However, particularly amongst rock engineers and managers there was enthusiasm for backfill and elongates, right up to the gully edges, leaving out packs on one or both sides of the gully. This would reduce effort in terms of transport of materials, and provide a more competent deep mining support e.g. Western Deep Levels. In particular the problem with using fill on both sides of a gully is that it can probably only work where an overhand mining geometry is used. Sidings are difficult to adequately support at depth with anything other than packs. Opinions over the need to pre-stress packs varied. In the West Rand area it was considered only essential to have prestressing on the VCR horizon where closure rates are perceived to be lower than on the Carbon Leader horizon. Pack size selection is a function of stope width, but many mining staff working narrow (1 m) stopes preferred long axis packs on gully walls because of increased stability and were dubious of the use of backfill on gully edges.

Long axis packs include units of between 1.5 to 2.2 m dimensions, square packs are generally smaller 0.75 m to 1.1 m. Preferences for packs along gullies range from long axis packs on both sides, to long packs one side, square ones the other, to square packs on both sides. Use of long axis packs on the up dip side occurs where the shoulder tends to be unstable. Usage on the down dip side may be required to ensure sufficiently wide sidings are cut.

Hangingwall support in gullies is unpopular and mining personnel would rather avoid it if possible and frequently doubt its worth due to poor installation (non-verticality of tendons). Lengths favoured range from 1.2 m to 1.8 m. The shorter hole can be drilled with normal stope steel; the 1.8m hole requires longer specially acquired steel and deeper gullies. Split sets are favoured because of simplicity of installation. End-anchored and grouted units are considered not user friendly.

The point of installation of tendons should be as close to the face as possible. This is easy in ASG's which are cut full height, but in the case of footwall lifted gullies, tendons are often further than 5m from the face and never drilled at the correct angle, because of gully depth. The first supports are installed 1.5m back from face of the lifted gully meaning that gully roof support starts as much as 7m from the face of the panel. Because gullies are high-risk areas it is recognised that tendons should be used. Mines recognise the need for using short airlegs for gully support, but

rarely do it. In many cases tendons are omitted, despite standards, because the gully height is too low.

Mining personnel have much confidence in rehabilitation techniques such as ground consolidation and sets with void filling. Basic support rules vary for fault and dyke intersections. Packs are considered the only gully edge support appropriate for these areas.

3.7 Blasting practice

Many mines agreed that smooth-wall blasting should be practised to reduce the amount of sidewall and hangingwall damage, particularly when advancing an ASG. A better control can then be exercised on the final gully dimensions and the support spacing. However, few mines followed their own advice. Most thought that the blast hole pattern in the vicinity of the toe of the face should be modified to minimise the potential for damage to the shoulder of the up dip side of the gully.

Blasting practice when footwall ripping of gullies was a recognised issue on those mines using these types of gully. Preferentially holes should be drilled horizontally on strike from the lifted gully face, whereas in practice long lengths of gully were often lifted at once using rows of holes drilled down from the stope footwall, giving poorer gully shape and conditions. Because footwall lifting can be achieved easily there is often a non-compliance with the hole pattern, coupled with erratic lengths of holes and overcharging.

3.8 Other mining practice issues

Other mining practice issues that arose included the following:

- The question of rigging of scraper snatch-blocks, and whether this should be allowed on support units such as rebars or even split sets. Opinion varied.
- Lock - up of broken ore in gullies.
- Support supply to face via gullies.
- Mudrushes in gullies and boxholes resulting from use of backfill. Gullies should not feed water and full run-off into box holes and a system to handle and divert water is required.

3.9 Conclusions based on industry opinions

The following broad conclusions can be drawn from the opinions of persons on the mines relating to gully practices and requirements. There appears to be good agreement between individual responses as to what constitutes a siding and its purpose. However, based on underground observations the standards, as defined by Mine Codes of Practice, are not always implemented.

With regard to best practice for gully geometry, reasonably good agreement was evident on such factors as gully shape, dimensions and blasting. On the issue of sidings, widely divergent views were expressed. This may reflect a depth “grey zone” indicating the transition between shallow depth where no sidings are required to a deep situation where they are necessary. In addition to this, differing perspectives and opinions are expressed by rock engineering as opposed to production personnel.

Generally, it was felt that poor gully conditions were in part the result of worker attitude and awareness. The deeper mines recognised this as a relatively more serious problem than the shallower mines did. People accept poor conditions when they work in them every day. The first step in any campaign to improve gully conditions has to involve a change in attitude if the drive is to be successful. At one mine this included on a high level, technical articles in the mine newspaper by the rock engineering department and on a lower level a mock up of a gully in the crush that the workforce walked through every day. On-the-job training in hazard recognition and blasting practice can be carried out by specially brought in educators coupled with clear strata control manuals or a training module with assessment of understanding of standards. Audits of underground performance in gullies, measured to appropriate standards, with regularly updated and published statistics and control documents for management would follow.

As a management tool a weekly report should be compiled dealing with gullies in a manager’s section, including comment on items such as direction, width, depth, and distance from face.

From a gully workshop attended at Savuka mine seven key parameters were identified by mine personnel as being areas of concern, namely drilling and blasting,

gully depth, support, span across the gully, sidings, gully directions and leads and lags.

With regard to support, the consensus was that different support types ought to be used at different depths, and the gully shoulder and the hangingwall were the areas that should be supported.

3.10 Planned industry gully practices

3.10.1 Gully geometries in use in the industry

A cursory inspection of mine standards and underground visits showed a number of common gully types in use on the mines. This section provides a review of these types, where mines plan to apply them, their design dimensions and support systems. Note that this is a review of what mines intend to do. What the mines actually achieve, and practices that are successful underground, are examined in subsequent sections.

3.10.1.1 Categorisation of gully types for data analysis

The gully types utilised on the mines can be broadly placed into six groups based on the use of headings, ASG's, sidings, footwall lifting, crush pillars and overhand versus underhand mining layouts. These can be summarised briefly as follows:

1. Advanced Strike Gully, ahead of the stope panel without siding.
2. As above with pillars left on the downdip side of the gully.
3. ASG with lagging downdip siding
4. As above with pillars left on the downdip side of the siding.
5. Cutting gully, stope face and downdip siding in line.
6. Gully is footwall lifted inside a wide, on reef, heading that is carried ahead of the stope panel face.
7. Gully is footwall lifted in the up dip corner of each stope panel when employing an overhand stoping layout.







Note that the numbers assigned to each gully type in the list above are used to categorise cases where underground observations were made (as listed and summarised in appendix 1).

The literature reviewed indicated that gullies without sidings were appropriate at shallow depth, ASG types and lagging sidings were tolerable at intermediate depth, while at greater depth where higher stress levels prevail, footwall lifting either in overhand panel configurations or wide headings should be practised. In some of the assessments made below, gully types are grouped into these three simpler categories: no sidings, ASG-type gullies with lagging sidings, and footwall lifted gullies.

3.10.2 Application of gully types by mines

The choice of gully standard on each mine is a factor of the overall mining layout, the ore carrying capacity of the gully and the range in mining depth (or stress conditions). Local preferences, and the degree, to which problems have been experienced, also influence choice. A summary of the gully standards in use on the mines visited is listed in Table 3.3. These are listed according to the gully categories defined in section 3.10.1.1.

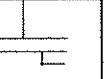
Table 3.3 - Gully standards in use on mines.

Gully Geometry								
Gully Type		7	6	5	4	3	2	1
Mine Name	Reef type							
Gold Mines								
Tautona	Carbon Leader	✓	✓					
Savuka	Carbon Leader	✓	✓					
Bambanani	Basal Reef		✓					✓
Elandsrand	VCR	✓	✓			✓		
Deelkraai	vcr		✓					
PDWASD	VCR	✓						
Savuka	VCR	✓	✓			✓		
West Driefontein	Carbon Leader		✓					
Kopanang	Vaal Reef			✓		✓		
Hartebeestfontein	Vaal Reef					✓		
Mponeng	VCR	✓				✓		
ARM	Vaal Reef	✓		✓				
St Helena	Basal Reef					✓		
Beatrix	Beatrix Reef					✓	✓	
Oryx	Kaikoenskrans Reef					✓		✓
Tau Lekoa	VCR				✓		✓	
Kloof	VCR	✓						
Durban Deep	Kimberley Reef							✓
Platinum Mines								
Northam	Merensky /UG 2	✓	✓			✓		✓
Amandebut	Merensky /UG 2				✓		✓	✓
Lonhro	Merensky/UG 2						✓	
Impala	Merensky/UG 2				✓		✓	✓

As noted in section 3.10.1.1, the gullies can be grouped into three simpler types, based on requirements to alleviate stress induced damage. The application of the different gully types as a function of depth, by the mines where data was sourced, is shown in Figures 3.1 and 3.2, for platinum and gold mines respectively. It is clear from these figures that the gully selection procedure is not, in practice, always made on the basis of mining depth, or stress related damage. For example, it should be noted that in the case of gold mines, Figure 3.2, with steeper dips ($> 35^\circ$), such as Bambanani, Oryx and St Helena mines, sidings are omitted even when mining at depth due to perceived mining practicalities of cleaning steep dipping sidings.

In many gold mines, Figure 3.2, where underhand mining layouts and moderate stress fracturing are encountered, the ASG method with a lagging siding is preferred as it permits flexibility in mining practice. Stope panel advance, gully advance and siding cutting can be carried out as relatively independent operations. In defiance of standards, sidings are often allowed to lag far behind gully faces. This is in part because cleaning down dip sidings is labour intensive, even at moderate dip. Although lagging sidings give rise to poor fracture patterns, it is often considered that adding more support is preferable to the extra controls and effort required when using a wide heading.

In general, wide headings and footwall lifting are only employed on those mines who have either proven, through hard experience, that other techniques are intolerable, or have only recently moved to a deep, high stress environment and have recognised a need to adopt new practices due to the change in mining environment.

The range in dimensions and support practices adopted for gully geometries at each of the mines is considered in the following sections.

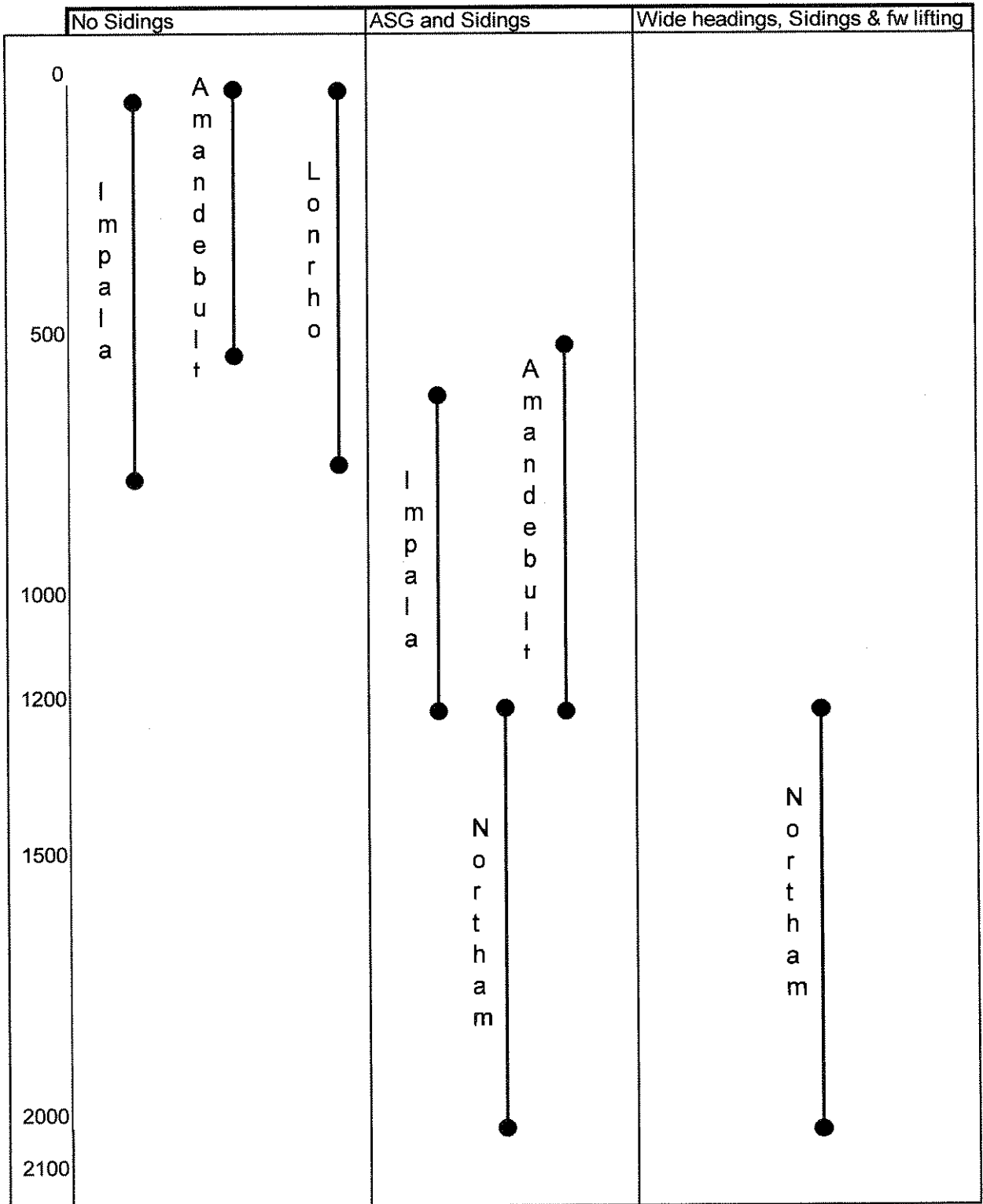

Figure 3.1 - Gully types in use versus mining depth on platinum mines.

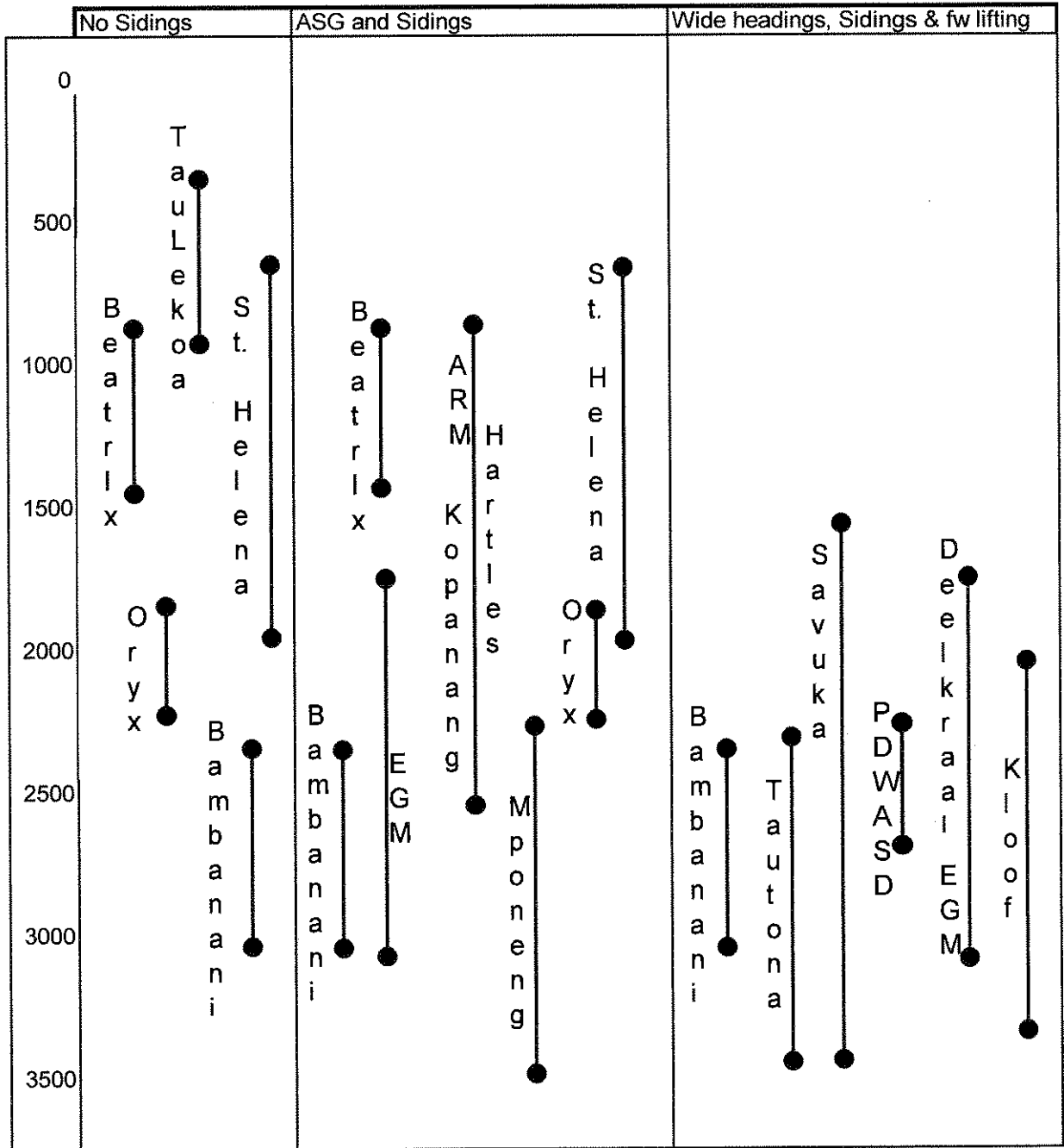

Figure 3.2 - Gully types in use as a function of mining depth on gold mines.

3.10.3 Summary of gully dimensions based on mine standards

As a means of gauging accepted practical limits for gully, siding, and heading geometries, the mine standards for each of the mine's visited were examined and standard dimensions recorded. For the six gully categories defined in section 3.10.1.1, there are eight essential dimensions, a to e, which define the overall gully geometry:

- a gully width
- b siding width down dip of gully
- c updip ledge width
- d lead from stope face to face of gully heading
- e distance siding can lag behind gully heading face
- f distance from face to gully (footwall lifted gully)
- g distance from face to pack or elongate (up dip side of gully)
- h distance from face to pack or elongate (down dip side of gully)

These eight parameters are shown in Figures 3.3 to 3.7, together with listings of dimension values drawn from mine standards in Tables 3.4 to 3.8. To a large extent sizes are dictated by mining practice. The following general points can be noted.

Gully widths range from conservatively 1.2 to 3 m when using scraper cleaning operations. The wider cases only occur at shallower depths where ground conditions are generally exceptionally good. In general, choice of scraper tends to dictate gully width, balanced against any need to limit spans to ensure hangingwall stability. Note that some mines (e.g. Mponeng) have historically had gullies (roadways) over 3 m wide when using LHD cleaning and countered any instability through intensive support.

Siding widths down dip of gullies tend to be as narrow as possible, ranging between 1.5 m and 2.7 m. Most are approximately 2 m by design, providing for the width of a pack plus a 1 m space behind to accommodate bulking of the stress fractured rock mass.

Where sidings are carried up dip of gullies (footwall lifted cases), gravity assists cleaning and wider sidings or ledges are accepted. The range is from 1.6 to 5.6 m in the case of wide headings. When gullies are footwall-lifted in the top corner of an overhand panel, the siding widths range from 2.1 to 3.2 m. The larger distances tend to be associated with the deeper mines with the severest stress problems where moving gullies away from curved fracturing around abutments becomes essential.

Tolerable or accepted leads that headings may be advanced ahead of stope faces is very varied and is influenced by local geology and mining requirements. A distance of 2 m appears generally adopted when a narrow ASG is cut. The reasons for this distance are unclear, as it is greater than required for scraper over-run, but does provide flexibility in terms of gully and stope panel blasting operations.

When wide, shouldered, headings are cut the standard distance that the heading can lead the stope panel face can vary from 3 m to 10 m. The larger distance originates from the deep Carbon Leader mines where, historically, headings frequently had to be advanced to re-establish panels by up dip mining.

Distances that footwall gullies may be excavated behind faces vary from 2 m to 5 m in the case of wide headings, and 5 m to 12 m in the case of gullies lifted in-panel. In the latter case, these gullies are often only required as escapeways in the top of the leading panel, hence miners let them lag as they are not essential to the day to day operations in the stope. Minimum distances are dictated by any space requirements to place temporary support between gully and stope/heading face. In a wide heading the gully lifting position is dictated by the heading lead distance plus the requirement that the gully is ahead of the stope panel face so that blasted rock can be scraped down the face and into the gully.

Support installation distances from the face vary from 3.5 to 7 m. In general these distances are designed to match in-stope support distances, and are not dictated by specific gully requirements. Distances for support installation updip and downdip of gullies varies slightly with downdip distances tending to be smaller when there is solid ground down dip of the gully.

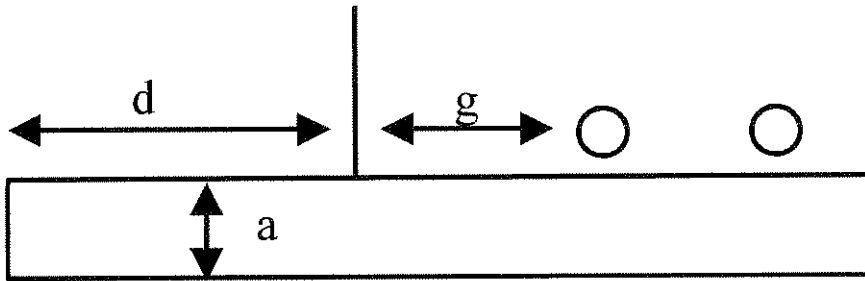

Figure 3.3 - No siding

Table 3.4 - Dimensions for gully with no siding

Mine	Impala	Amandelbult
Reef	Merensky Reef	UG2 Reef
a	1.2 (2m support)	± 1.5m
d	3	?
g	4	5
Pack/stick	Sticks	Sticks
Hangingwall	Shepherds crook 1.8m and 1.2m	1.2m grouted roofbolts
Support	3-3-3 in sidewall and hangingwall	3-3-3

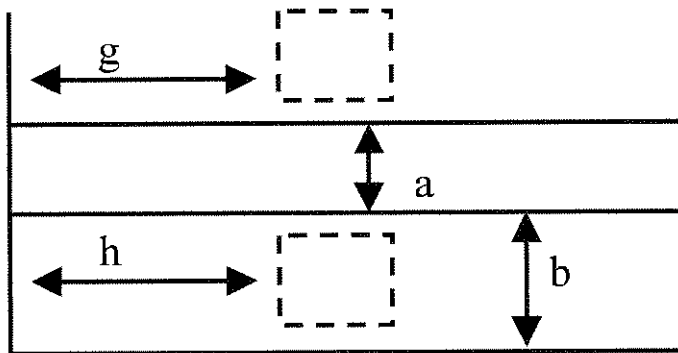

Figure 3.4 - Gully in line with face

Table 3.5 - Dimensions for gully in line with face

Mine	Kopanang	ARM
Reef	Vaal Reef	Vaal Reef
a	2.4	2 - 2.4
b	2	3
h	4.5	3.5 – 4.5
g	4.5	3.5 – 4.5
Packs	1.1 square packs both sides	1.1 square composite packs both sides
Hangingwall support	1.5m grouted rock studs 2-1-2-1	1.5m rock studs or gewi bars 2-2-2-2

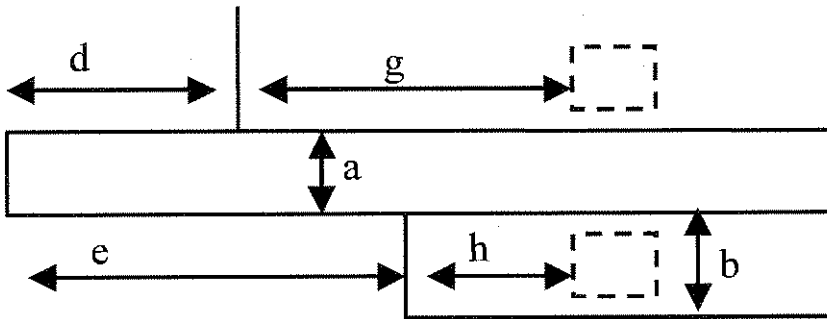

Figure 3.5 - ASG gully heading with lagging siding

Table 3.6 - Dimensions for ASG gully heading with lagging siding

Mine	Kopanang	Haartebeesfontein	Bambanani	Northam	Mponeng	EGM *	St Helena	Beatrix	Oryx
Reef	Vaal	Vaal	Basal	Merensky	VCR	VCR	Basal	Beatrix	Kalkoenskrans
a	2.4	2.4	2	2	1.6	1.8	2	3	2.5
b	2	2	2.1	1.6	Pack+1	2.1	1.5	2	2
d	2	2	2	6	2	2	2	2	2
e	6.5	7	6	11	2	2	5	4	4
h		5.2	5	5	3.8	4	4	5	5-7
g	4.4	5.2	3.5	4.5	3.8	6	4	5	5-7
Packs	Double pack both side	Staggered packs up dip	75 X 110 both sides	75 X 75 pack both sides	Long axis packs up & down dip	Fill up dip. Pack	75cm square both sides	110 X 110 both sides	75 X 110 both sides
Hwall supt	1.5m grouted bolts 1-1-1	Grouted rebar 2-2-2	none	none	none	1.5 grouted rebar 2-1-2-1	1.8 sheperds crook 2-1-2-1	None. Rockstuds if sidewall > 1.4	none

* EGM = Elandsrand Gold mine

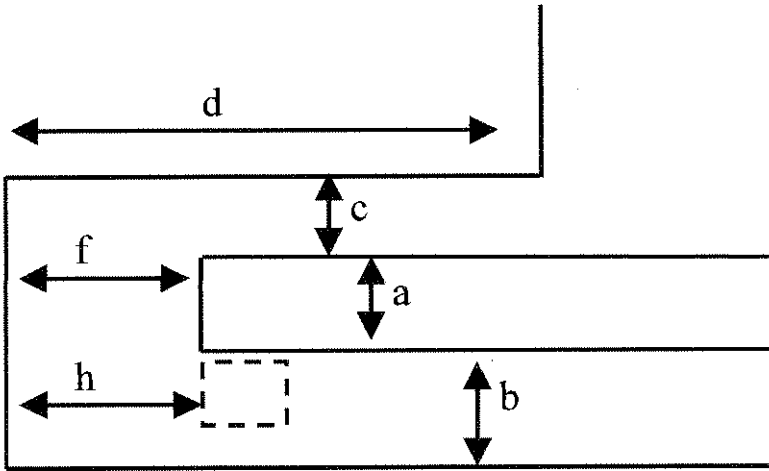

Figure 3.6 - Wide heading

Table 3.7 - Dimensions for gully with wide heading

Mine	Deelkraal	Elandsrand	Western Deep Levels	Bambanani	West Driefontein	South Deep	Northam
Reef	VCR	VCR	CLR	Basal	CLR	VCR	Merensky
a	2m	1.8	2		1.8	1.5	2
b	2.2	2.3	3	7.5	1.6	2.7	1.6
c	2.2	2.3	3		5.6	2	1.6
d	4.5	4.5	10	3	?	4-8m	6
f	2	4.5	5	-	5	> 4	?
h	5.5	4	3.7	4	4.5	4	?
Pack size	Small packs downdip	0.75 & 1.12	1.5 & 1.5	1.5 & 1.5	1.8x1.2 1.2X1.2	1.1X1.1 updip 2.2X1.1 downdip	75X75 packs both sides
HWall Supt	Rebar/Split sets 1-2-1	1.5m grouted rebars 1-2-1	Tendons 1-2-1			none	None

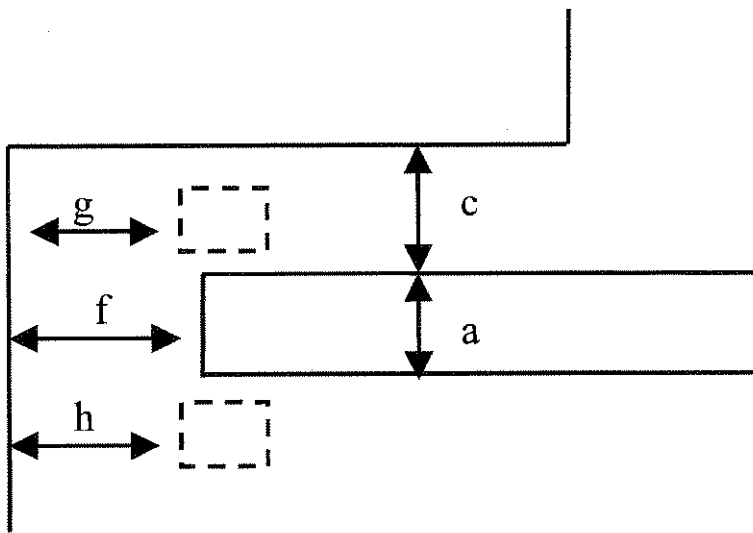

Figure 3.7 - Gully at top of the panel

Table 3.8 - Dimensions for gully at the top of the panel

Mine	Tautona	Savuka	Savuka	ARM	EGM *	Bambanani
Reef	CLR	VCR	CLR	Vaal	VCR	Basal
a	1.6	1.6	1.6	1.8	1.8	2
c	3.2	3.2	3.2	± 2.5	2.3	2.1
f	5	5	5	< 12	6	?
g	3.7	4.3	4	3.5	4	3.5
h	3.7	4.3	4	3.5	4	3.5
Packs	1.5X75 top 75X75 below	2.2X1.1 packs both sides	2.2X0.75 packs both sides	110cm double packs both sides	1.12X75 packs both sides	110X75 packs both sides
HW supt	Tendons 1-2-1	None	none	none	1.5 rebars 2-1-2	None

* EGM = Elandsrand Gold Mine

3.11 Support strategies currently in use

Gully support generally comprises two parts:

- Support installed along the edges or on the shoulders of the gully, such as packs, props, or even pillars, which provide overall stability and, in theory, limit massive collapse.
- Support installed in, or across, the immediate gully hangingwall. This is intended to prevent smaller, or more local falls from occurring. Included here would be tendons (rebars, splitsets, etc.), meshing and lacing, trussers, shotcrete, plus sets and cribbing gully liners and void filling.

Levels of support required depend on local ground conditions and longer-term damage or deterioration due to stress, support removal or seismic activity. Note that support removal is not uncommon: packs may become dislodged by cleaning activities or may be deliberately blasted out to create cubbies when moving face winches. In terms of planned mine practice, support techniques can be grouped under three headings:

- Basic support installed as the gully is advanced and designed to cope with typical ground conditions on the mine.
- Additional support, required where adverse conditions are encountered, such as highly stressed remnants, very broken or jointed ground, and during fault negotiation (all typically special areas)
- Remedial support required to rehabilitate gullies where damage has occurred.

Planned support measures are described under these three headings in the section below. Choices of support units for basic support at each of the mines should be dictated geotechnical environment, but are frequently strongly influenced by cost and special price deals offered by suppliers. Local preferences and perceived or actual problems experienced with certain units also play a role.

3.11.1 Basic support

The following section is a review of basic gully support included in mine standards. An evaluation of support success is based on underground observations later in this report. Figures 3.8 and 3.9 show the distribution of various support types in use in relation to mining depth. The two figures cover, separately, gully edge support and basic gully hangingwall support.

Basic gully edge support includes packs, elongates, pillars and backfill (Figure 3.9).

Pillars are used down to approximately 1000 m depth. In two cases examined conditions were sufficiently competent to require no further support, however generally stiff support, either mine poles with or without pre-stressing, are used in conjunction with the pillars. In some cases packs are also added, where conditions give rise to a more broken hangingwall.

Pack systems take preference from 1000 m down, where stress induced fracturing is observed and ground conditions progressively deteriorate with depth. Two sizes of packs are commonly used, 75 cm and 110 cm. In most mines packs are pre-stressed, however in certain deep mines, where closure rates are very high, pre-stressing is considered unnecessary. One case was encountered (Vaal Reef) where pre-stressing was omitted at 1000 m depth and wedging only was used, where closure rates are low. Pack types include brick composites, solid timber mat packs, end-grained timber mat packs (Hercules, Apollo, Brutus, and Lexus) and cementitious brick packs (Durapak). Only the latter variants are designed by manufacturers to conform to the CSIR guidelines for gully pack performance detailed in section 2. Note that monolithic packs are currently being used on Matjhabeng, Joel and Great Nologwa mines.

Elongates used along gully edges are only used on their own at shallow depths above 1000 m. In deep mines they are used in addition to packs and assist early installed support, which can provide gully hangingwall stability by being placed closer to the face than a pack. Elongate types include non-yielding mine poles (shallow mines only), and yielding types with pre-stressing.

Backfill with elongates alone is used on certain of the deep Carbon Leader mines, with fill brought to the immediate gully edge without packs on the down dip side of

the gully, and in some cases to the edge of the up dip side of the gully also. In this case, elongates are installed along the gully edge to provide fill confinement.

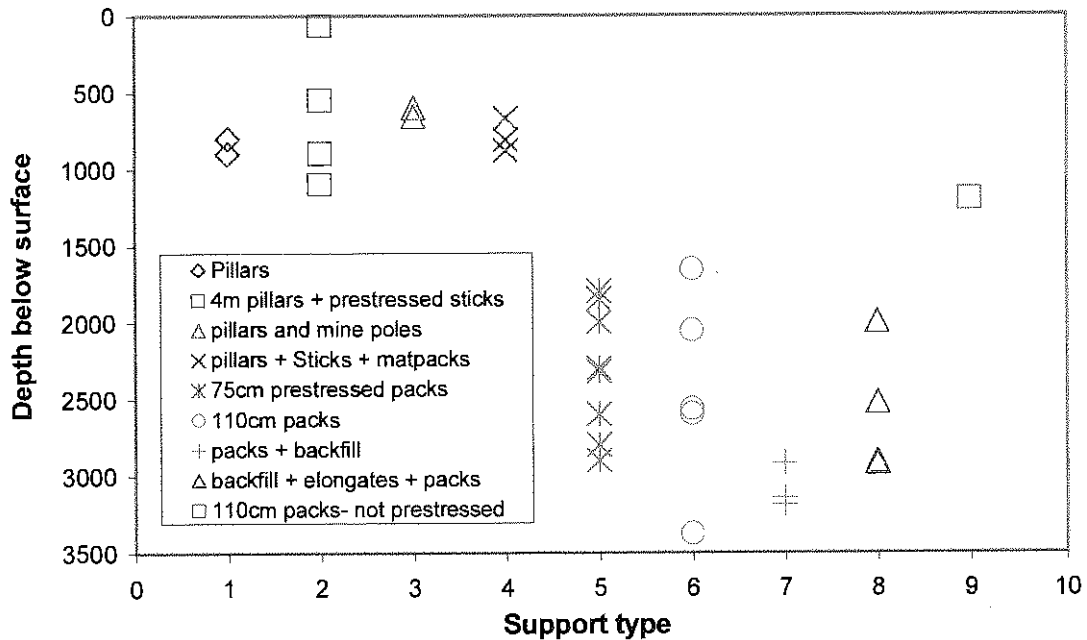

Figure 3.8 - Application of gully edge support types as a function of mining depth on gold and platinum mines, as required in mine standards

Basic gully hangingwall support, as listed in mine standards, is limited to various tendon types only. Figure 3.9 shows application as a function of mining depth. Figure 3.10 shows the relative preference for tendons of different lengths.

At shallow depth the preference is for end-anchored rockbolts, sometimes grouted, which can be pre-tensioned. These are well suited for retaining larger blocks created by bedding and jointing. As depth increases the use of grouted rebar tends to predominate where, as a result of the more highly fractured nature of the ground, a bond to the rock is desired along the full length of the tendon. Where immediate hangingwall support is required in very fractured ground at depth, splitsets (friction bolts) are used. Figure 3.10 indicates a preference for longer tendons as mining depth increases. At shallow depth tendons are generally only required where defined partings are present in the immediate first 1 m of hangingwall. At greater depth, fragmentation creates a potential for higher falls, particularly when there is a risk of exposing weak stratigraphic units such as the Green Bar shale and quartzite middling of the Carbon Leader Reef.

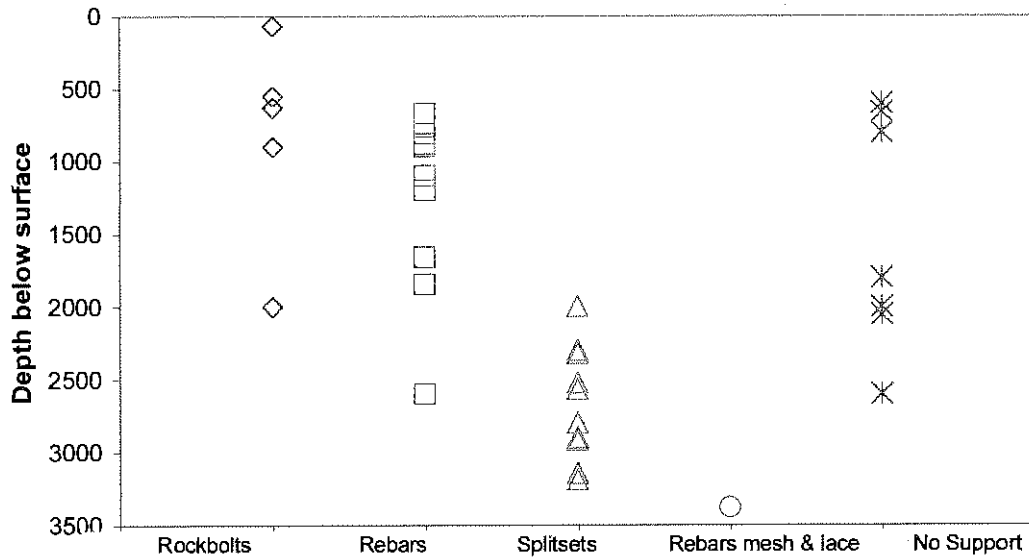

Figure 3.9 - Application of basic gully hangingwall support types as a function of mining depth on gold and platinum mines, as required in mine standards

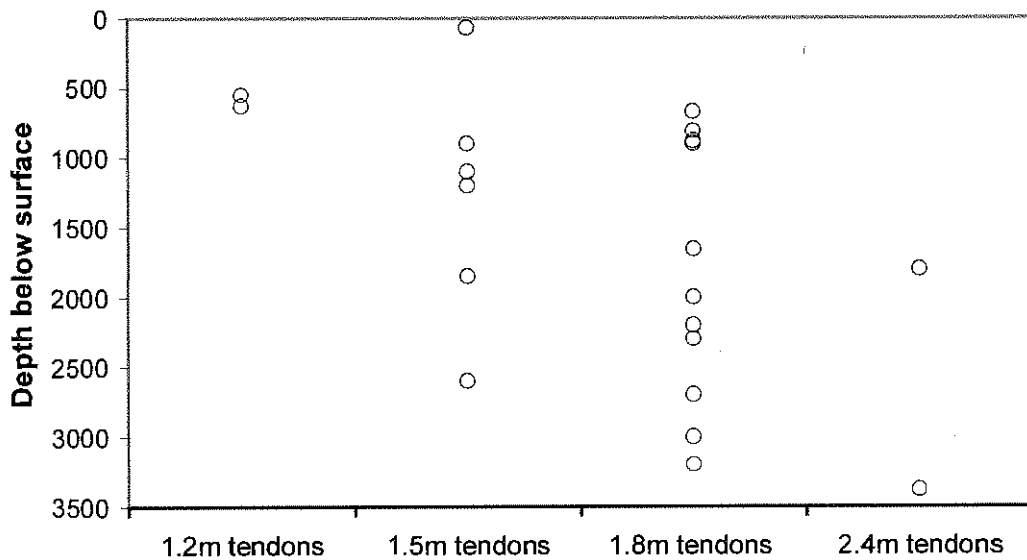

Figure 3.10 - Choice of tendon length as a function of mining depth on gold and platinum mines, as required in mine standards

3.11.2 Additional support

Mine standards generally exclude conditions where additional support is required in gullies during gully advance due to poor ground conditions or increased level of hazard and risk.

At shallow depth if areas of increased jointing or the presence of faulting result in a fall of ground hazard, the standard practice is to reduce spans over gullies by omitting sidings (provided stress damage does not compromise stability) and introduce additional in-stope pillars on both sides of gullies.

As depth increases and poor ground largely results from stress damage coupled with geological features, additional support measures are required. At depth, the risk of seismic activity often leads to additional support requirements in anticipation of potential damage, even though ground conditions may be competent. Additional support measures may consist of:

- The introduction of tendons (where none is already required in mine standards).
- Increased density or length of tendons (i.e. a change from a 2-1-2-1 pattern to a 3-2-3-2 pattern).
- Addition of mesh and lacing (unpopular as normal ongoing gully support, unless there is considerable vertical height in the gully, as blasting and scraping tend to remove it. It is also time-consuming and awkward to install in the confines of a stope). Furthermore, if a gully is damaged by rockbursts, it is very difficult to re-open a gully that has wire meshing and lacing. It also hampers rescue operations in damaged gullies.
- Injection grouting to cement fractures (ground consolidation).
- Gully liners – arched steel segments that rest on a channel iron suspended from packs, providing complete areal coverage over the hangingwall. Grout-filled pack pre-stressing bags are used to fill the generally small void between steel liner and hangingwall rock surface.

- Other forms of hangingwall support between packs such as steel girder or timber sets suspended from bullhorns or built into packs, with timber cribbing.
- Cable trusses installed in holes either side of the gully, with timber cribbing over the gully hangingwall.

There are limits to the form of additional support that can be installed close to gully faces. The main problem lies in the region from the gully (or heading) face to the point where packs are installed. Most forms of total area coverage for the hangingwall, which are capable of supporting a large thickness of potentially unstable ground, rely upon suspension from packs.

Any form of strapping or meshing stands a risk of damage from scraper or blasting, and, attached to tendons, relies on unstable ground thickness being less than the length of tendon. Installation of long tendons in gullies, particularly close to the face, is limited by gully height restrictions. Attempts to increase tendon length are frequently ineffective because the angle of installation gets flatter as the length of hole being drilled increases.

3.11.3 Remedial support

Remedial support is required when falls of ground occur, conditions become exceptionally unstable, or support has been removed or is ineffective.

Techniques frequently require sealing off a hangingwall surface which may be inaccessible (due to high fallouts), loose and prone to further collapse. In many cases drilling holes for re-support with tendons is dangerous or impractical. Where these conditions exist, and a gully cannot be abandoned, remedial work options may include:

- Void filling – where steel girder or timber sets are installed between packs across a gully, or sit on the gully shoulders, timber cribbing is placed across the sets and foamed cement is used to pack the remaining void up to the hangingwall surface.
- Timber sets and skeleton cribbing (an old technique, largely replaced by void filling in most mines).

- Gully liners (described in the previous section).

Where the hangingwall is solid enough to drill into, remedial work might include:

- Ground consolidation.
- Re-support with rebars (or similar tendons), cable anchors, and mesh and lacing.
- Shotcrete
- Cable trusses and cribbing

CHAPTER 4 – EVALUATION OF CURRENT PRACTICES BASED ON UNDERGROUND INSPECTIONS

4.1 Introduction

The following section is based on observations made during the underground inspections of gullies across the industry. It provides a critical review of how mine practice compares to intended standards and highlights the nature of rock damage relative to gully geometry, mining depth, problem areas, and solutions.

The success of all mining methods is strongly influenced by the depth at which the reef is mined. Thus two factors were considered to be the most important, reef types mined, and the various depths and the stress regimes encountered. Conditions have been rated and broad assessments made of support success or failure. Certain measurements were collected during these visits, e.g. gully widths and support spacings, and these are used as a means of assessing the appropriateness of the mine standards.

4.2 Rating of gully conditions

For the purpose of evaluating the success of the choice of gully geometry, support methods and mining practices, a simple rating system was adopted based on observed conditions. Three categories were used:

1. Good conditions – Very stable conditions, generally confined to shallow depth, negligible fracturing, no hazardous conditions.
2. Moderate conditions – stress fractures or geological conditions give rise to broken ground, but hazards are controlled through appropriate application of support and mining practices.
3. Poor conditions – stress fractures or geological conditions give rise to very broken ground, where the likelihood of falls of ground occurring are high and additional support is, or has been, required. Included in this category would

be areas where loose ground is frequently observed, gully sidewall integrity has been lost, and the quality of support installation is visibly poor.

There is clearly a certain amount of subjectivity when rating gullies according to these categories, however, for the purpose of evaluating the appropriateness of gully practices, this simple rating scheme was found adequate.

4.3 Mining practice compliance with mine standards

In addition to the simple rating system outlined in section 4.2, and as a means of checking whether mines achieve the results that they intend, compliance with mine standards has been checked for certain key dimensions. In most of the gullies inspected underground, gully widths and support spacings both across and along the gully were measured. These, listed in detail in appendix 1, have been compared to mine standard values, to provide a measure of compliance.

Note that, in terms of gully widths, deviation from standard is not only influenced by careful mining practice, but is also influenced by rock mass behaviour. For example if considerable stress fracturing occurs around an ASG, gully sidewall stability may deteriorate and sidewalls break back. This results in an increase in gully width and support spacing across the gully and hence a potential for deviation from standard. Hence compliance with mine standards not only provides an indicator of poor mining practice but also indicates those places where mine excavation and support design is inadequate or inappropriate.

Hence an examination of gully width provides a measure of the practicality, or achievability, of gully geometries. An examination of support spacings provides a measure of the additional level of corrective action required i.e. support spacing may be reduced where gully conditions deteriorate.

Figure 4.1 shows measured gully widths from each of the underground sites plotted against dimensions drawn from the relevant mine standards. The graph is divided into two areas where observed cases lie either within, or outside, of standard. The various gully geometries are indicated. Of the sites inspected, gully widths were within standard in 63% of cases, and outside standard dimensions in 37% of cases. Note that these figures include all data, from all reefs, all gully types and all depths.

The most severe deviations from standard appear to occur when aiming to achieve a gully with a standard width of 2 m or less.

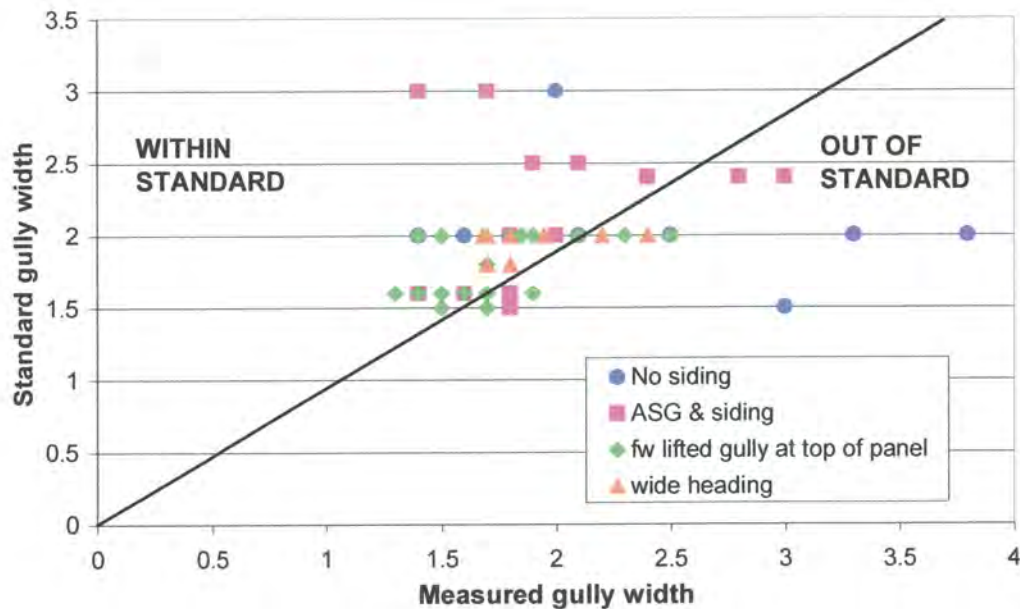

Figure 4.1 - Comparison of measured and standard gully widths for cases examined underground in gold mines. Considerable deviations from intended mine standards are apparent

To get a clearer picture of the ease of correct implementation of each gully geometry, the effect of the stress environment has to be considered. Figure 4.2 shows the measured gully widths plotted against mining depth. There appears to be a trend towards narrower gullies at greater depth, reflecting a reduction in stable spans between support as stress fracturing becomes intense. To examine compliance to standards as a function of mining depth the actual gully widths are normalised against the mine standard for each case, then plotted against mining depth in Figure 4.3.

To enable the broad performance of the various gully types to be assessed, the observational data in Figures 4.2 and 4.3 can be subdivided into shallower or deeper cases, taking 2000 m depth as a convenient dividing line. The proportion of cases where standards were met is summarised in Table 4.1. Above 2000 m the gully

types observed either have no sidings, or the sidings lag. At or below, 2000 m footwall lifted types start to predominate in the underground cases examined.

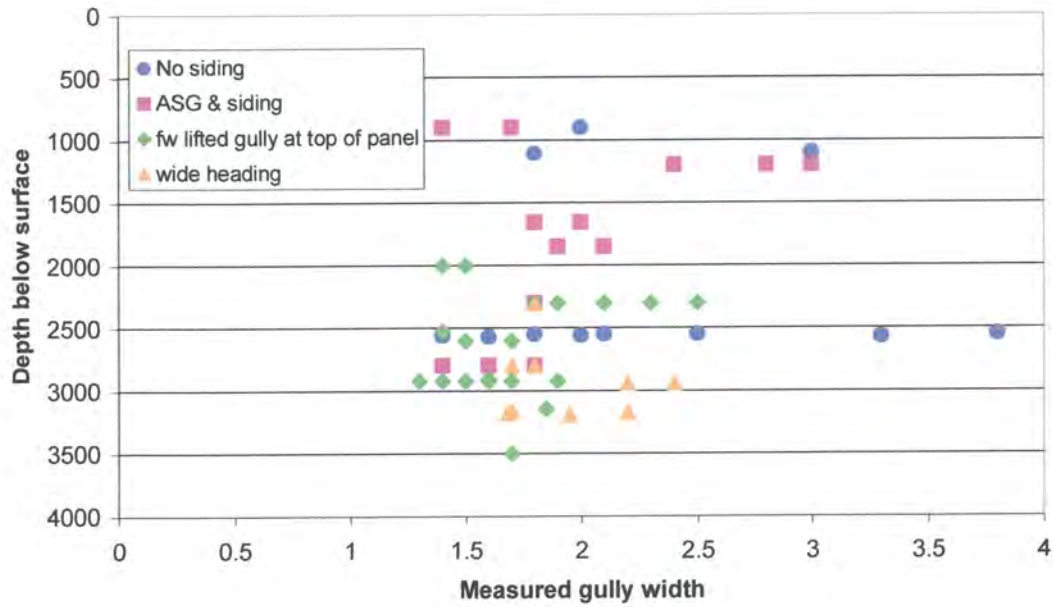

Figure 4.2 - Observed gully widths as a function of mining depth in gold mines

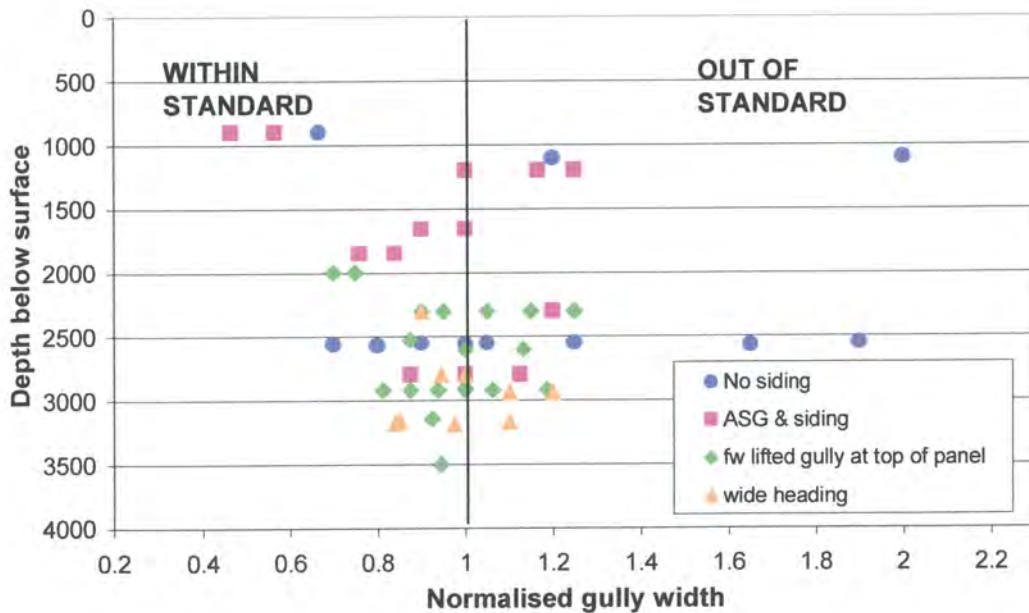

Figure 4.3 - Deviation from standard gully widths as a function of depth in gold mines. Observed gully widths (from Figure 4.2) are normalised against mine standard widths

Table 4.1 - Comparison of actual gully widths to mine standards

Above 2000 m depth			
<i>Gully Type</i>	<i>No. cases within standard</i>	<i>No. cases outside standard</i>	<i>Percentage of cases where width exceeds standard</i>
No siding	1	2	66%
ASG with lagging siding	7	2	29%
Total above 2000 m	8	4	50%

Below 2000 m depth			
<i>Gully Type</i>	<i>No. cases within standard</i>	<i>No. cases outside standard</i>	<i>Percentage of cases where width exceeds standard</i>
ASG-type gullies			
No siding	4	4	50%
ASG with lagging siding	2	2	50%
Total ASG gullies	6	6	50%
Footwall lifted gullies			
Top of panel	12	6	33%
Wide heading	6	3	33%
Total f/w lifted gullies	18	9	33%

In Figure 4.3, with the exception of gullies without sidings at depth, the measured gully widths are less than 30% greater than standard, in cases where the standards were not met. Below 3000 m gullies are either within standard or no more than 10% in excess, indicating a general recognition that conditions are less tolerant of lax mining practices.

Table 4.1 indicates that ASG cases without sidings seem to be problematical at all depths, although it should be noted that measurements were not taken in many of the shallower cases listed in appendix A. Hence any assumption of poor compliance to standards at shallow depth on the basis of this data may be inaccurate.

In the case of ASG's with lagging sidings Table 4.1 shows an increase in the proportion outside of standard as depth is increased, moving from 29% to 50%. This

is expected, due to the increase in stress related damage in the heading walls. However, even at moderate depth ASG's without sidings are inappropriate.

Below 2000 m depth, footwall lifted gullies are clearly more effective than ASG types, with 33% compared to 50% outside of standard. Note that overall the ASG types are equally out of standard at all depths. This is surprising, as it would be expected that standard dimensions would be readily achievable without sidings, or with lagging sidings, at shallower depth where stress induced fracturing is less prevalent. The suggestion is that tolerable stable spans are generally greater than standard spans at shallow depth and that mine personnel are not under the same pressure to minimise span to maintain stability.

As a test of run-of-mine ability to work within standards at shallow depth, data was sourced from a platinum mine operating in the 300 m to 950 m depth range. The mine has a risk control system where stope observers routinely audit all stope panels, gather data relating to conditions, and take measurements to check compliance to standards. Stope observer records for 223 panels were examined. The standards for this platinum mine called for ASG-type gullies developed 1.2 m wide, with the hangingwall span across the gully from pillars to timber poles being a maximum of 2 m. At selected points along the gullies, the observers take actual measurements of both the gully width and the inter-support span. These values for 105 gullies have been examined and are plotted against each other in Figure 4.4.

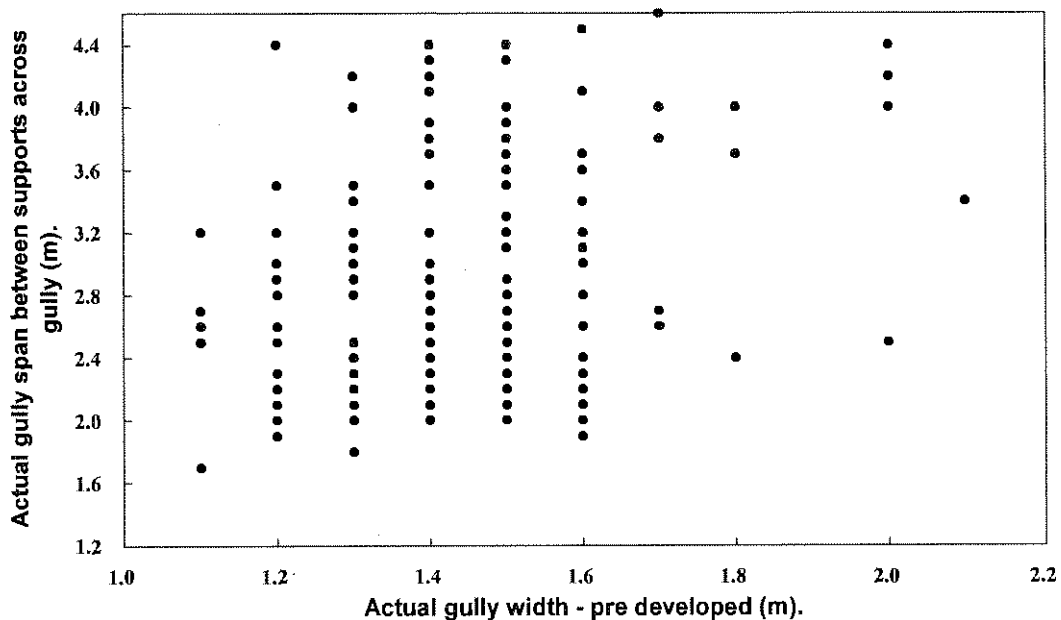

Figure 4.4 – Measured gully spans and widths on a platinum mine

Figure 4.4 might be expected to show an obvious relationship between gully width and span between support across the gully, however this is not readily apparent. For any actual gully width there is a considerable variation in the span between support units from approximately 1.6 to 4.6 m.

To examine compliance to standards the measured data have been normalised against the mine standard dimensions, and are presented in Figure 4.5. Only 3% are within standard for both gully width and supported span. 9% are within the support span standard, and 19% within the gully width standard. It should be pointed out that data was chosen at random from the mine's records, and the mine's observers visit all panels, not just problem areas. Reports do not indicate poor conditions in the gullies from which the measurements were taken. The conclusions here are that possibly blasting practice could be improved to reduce gully width, and that excessive support spacing may in part result from incorrect gully width. However, absence of poor conditions tends to suggest that the actual dimensions are tolerable in practice and do not require dimensions as tight as those specified in the standards.

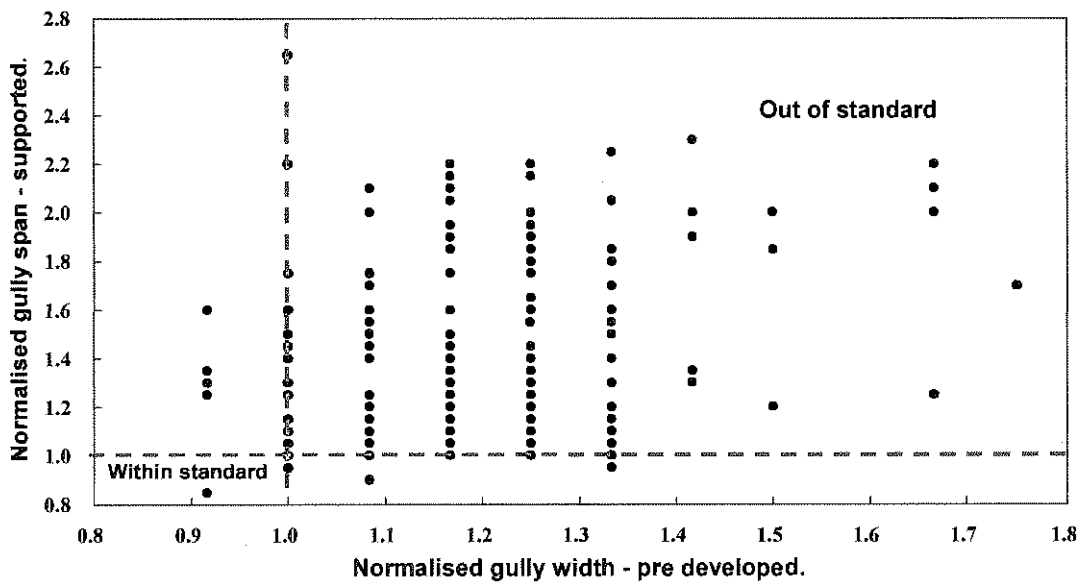

Figure 4.5 - Relationship between gully width and span between support across the gully when normalised against standard dimensions on platinum mines

If the frequency of occurrence of the two dimensions in this platinum mine data are considered, the gully width (as shown in Figure 4.6) is found to be rarely no more than 30% in excess of standard. This is the same general level of deviation noted across the industry during mine visits (Figure 4.3).

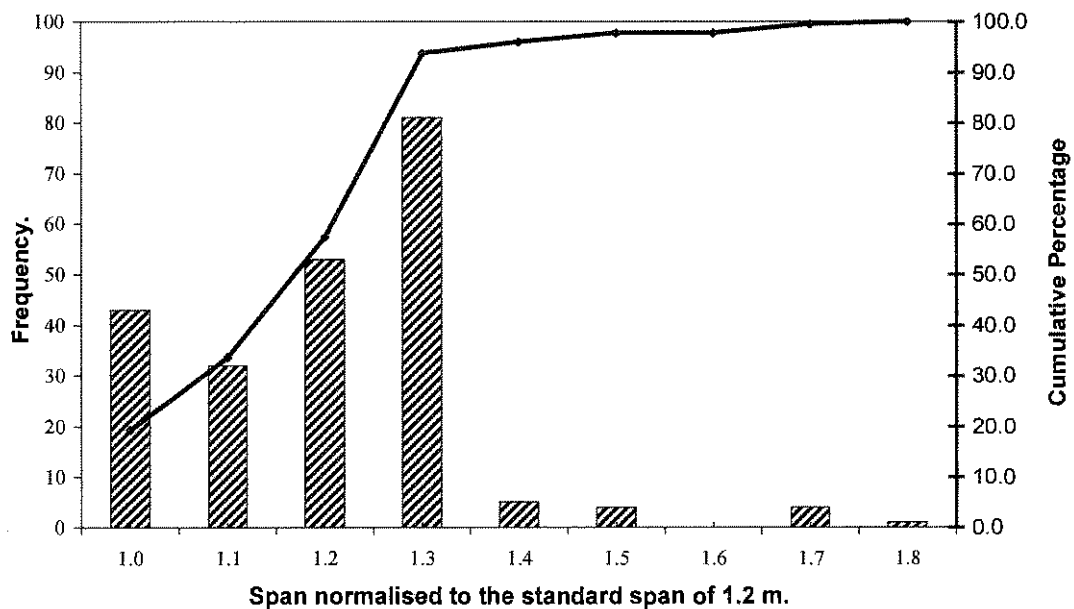

Figure 4.6 – Frequency of occurrence of gully width, normalised to the mine standard width of 1.2 m on platinum mines

For the span between support, the deviation from standard is considerably greater, reaching 130%, as shown in Figure 4.7. The overall impression is that the hangingwall must be very competent and stable and that support span is not considered a critical issue on this mine by the mining personnel. In many circumstances wider spans than specified by the standards are likely to be tolerable.

Data gathered during mine visits for this project indicate that this platinum mine is unusual and that in most mines there is considerable recognition of the need to get support spacings within standard. Measurements were made of actual spacings between packs along gully edges (in addition to the span across the gully) and are plotted against mining depth in Figure 4.8. Spacing along the gully shoulders range from 1 m to 2.2 m.

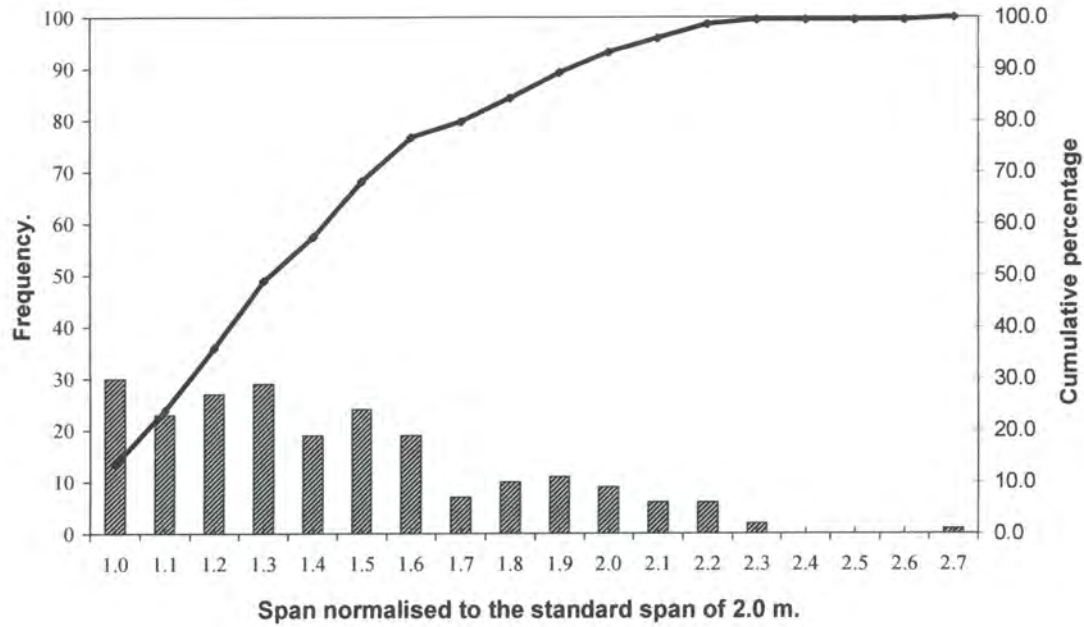

Figure 4.7 – Frequency of occurrence of spans between support across platinum mine gullies, normalised to the mine standard span of 2 m

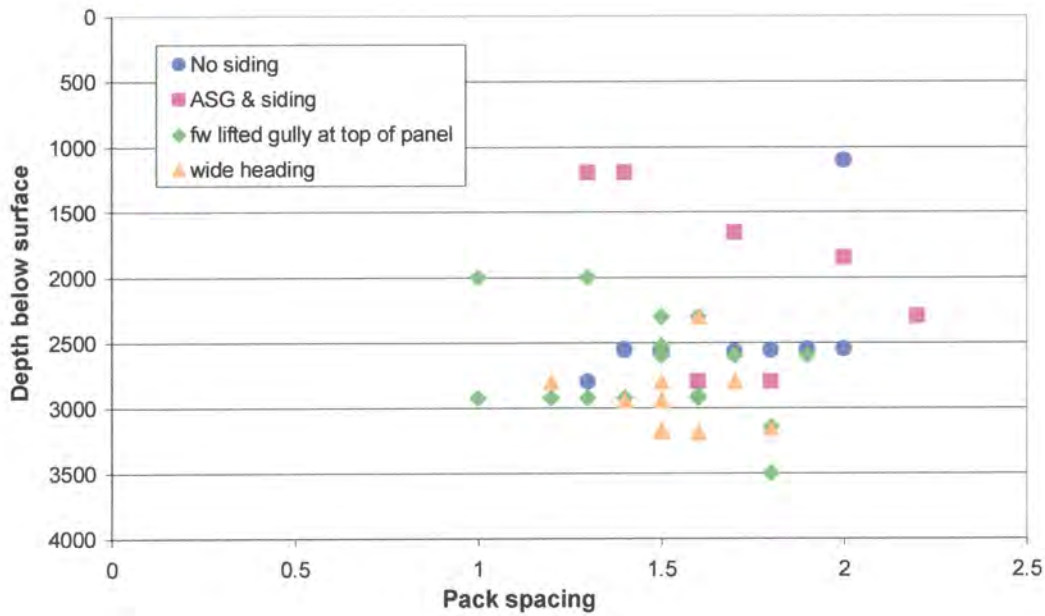

Figure 4.8 – Observed spacings of packs along gully shoulders at various gold mines industry-wide, shown versus mining depth

As was done with the previous data measured during industry-wide visits, the pack spacings along the gully shoulders shown in Figure 4.8 were normalised against the standard spacing and the result is shown in Figure 4.9. This graph indicates that only 5% of observed cases showed spacings in excess of standard and in some cases (generally where ground conditions could potentially give problems), spacings are as much as 40% less than standard.

The two cases where standards are exceeded are both ASG-type gullies with lagging sidings. There were no obvious reasons why these should be outside of standard.

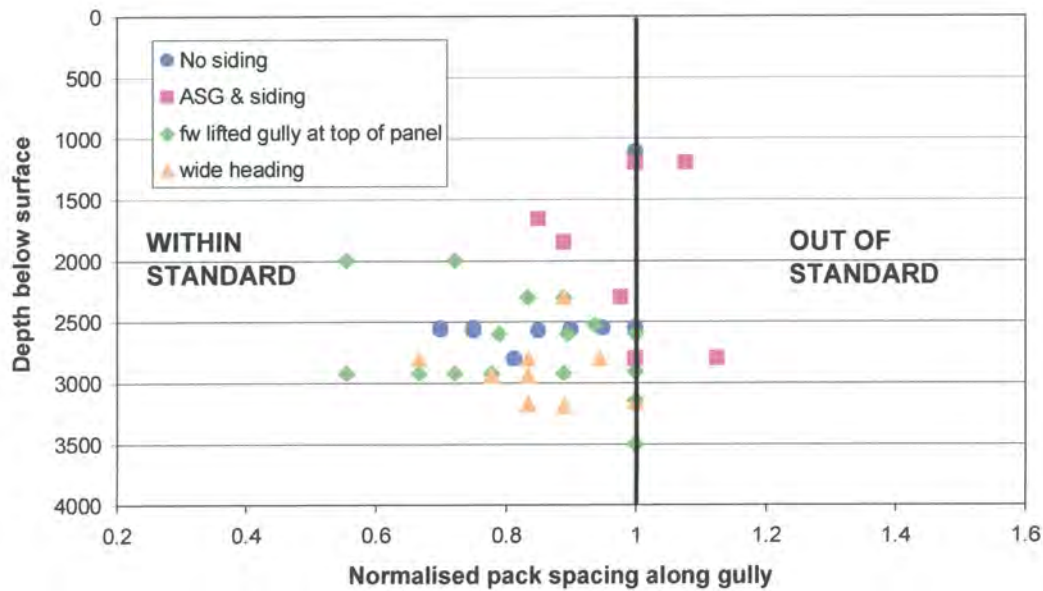

Figure 4.9 – Observed spacings of packs along gully shoulders at various gold mines industry-wide, normalised to local mine standard values, shown versus mining depth

4.4 Summary of observed gully behaviour resulting from geometry, stress state and ground conditions

From the gully cases examined a reasonable assessment can be made of the effect of gully layout on gully stability under similar geotechnical conditions.

For this review gully practices were examined under three broad categories:

- Shallow depth, where stress fracturing is largely absent.
- Moderate stress, where hazards result from a mix of stress fracture and geological causes.
- High stress where the rock mass is highly fractured and best practices revolve around the manipulation of stress induced fracture orientations.

Opinions on acceptable or tolerable practices, particularly under moderate stress conditions, vary considerably. In some cases very poor conditions were observed because mines persisted in using practices that had been used effectively for decades under lower stress conditions, but became increasingly inappropriate as stress levels slowly increased due to increase in mining depth, or extent of mining. Mines had failed to recognise these slow changes over time and had not adapted mining practices other than through increases in support density i.e. they benched up support but did not change gully designs or mining practice.

4.4.1 Shallow depth

For the purpose of this section, shallow depth is taken as a generic heading for those working places where either stress fracturing around the stope perimeter was not significant (including overstoped areas), or where shallow mining pillar-supported layouts were in use. When considering crush pillars stress fracture damage in and adjacent to pillars becomes problematical as the pillars crush. Comment on this is included here rather than in the subsequent section.

4.4.1.1 Geotechnical conditions

Broadly, geotechnical conditions in gullies at shallow depth are strongly influenced by local geological structure, plus any rock mass damage incurred around crush pillars. The occurrence of these conditions is highly variable and localised, requiring immediate recognition and local corrective measures to minimise hazards.

Stress fracturing is not a concern and, in very competent ground such as massive high strength quartzites, the rockmass is very stable. Unsupported gullies can be cut (Figure 4.10). Sidewalls of gullies tend to break along joints and hangingwall problems relate to bedding and the creation of brows (Figure 4.11) on the gold mines. In the Bushveld complex bedding-type partings are largely absent and joint-bound wedges or zones of more intense jointing are the main concern (Figures 4.12 and 4.13). In general, where such hazards exist, shallow mining practice includes the addition of extra in-stope pillars either side of gullies to limit spans and ensure stability, plus the omission of any downdip sidings.



Figure 4.10 - Gully cut in a high stope width area in competent, jointed strata on the Beatrix reef at approximately 900 m depth. The gully is in the centre of a panel mining high channel widths, and is very stable, tending to break out along joint planes



Figure 4.11 - Brow in massive, bedded quartzite over a gully on the Beatrix reef at 900 m depth



Figure 4.12 - Hazard resulting from joint-bound wedges over a strike gully on the Merensky Reef at approximately 300 m depth. An additional pillar is left on the up dip (left) side of the gully to reduce the risk of a fall



Figure 4.13 - Zone of dense jointing creating a hazard on the Merensky Reef at 600 m depth. Siding left on left side of gully and additional in-stope pillar left on right

Pillars may create hazards in gullies. The strategy of employing pillar systems as primary stope support to provide local as well as regional stability has been used successfully over many years for mining in the Bushveld Complex.

In scraper - based breast stoping systems, the strike gullies are located, for practical mining reasons, on the immediate up dip side of the pillars. When up dip or down dip stoping is practised, the gullies may be placed next to the pillars or alternatively mid way between them. This option allows throw blasting from the two shorter panels into the gully.

Pillar designs vary. Where the average depth of mining is about 400 metres below surface, with the deepest workings extending down to around 700 metres below surface, a common strategy for mine stability is to design rigid pillars that are stable and do not fail. Therefore as depth increases so does the width of the pillars. Dimensions include 6 metres on strike by 4 metres on dip (for depths less than 100 m) at Impala Platinum and 4 metre square pillars are used down to a depth of about 535 metres below surface on Amplats mines. Rigid pillars generally show minimal damage around their edges.

Where crush pillars are used (typically at depth from 500 to 1100 m) dimensions include 6 metre long by 3 metre wide (Impala Platinum), and 4 metres on strike by 3 metres on dip (Amplats). Crush pillars become highly fractured by design and may cause damage locally in the hangingwall adjacent to the pillar. This may impact on gully stability.

Mining depth at Northam ranges from 1200 to about 2000 metres below surface. The primary stope support method for Merensky Reef consists of backfill, which is placed on a mine wide basis. Three metre wide crush pillars are used in certain sections of the mine where water bearing geological features present a risk of water inflows.

Low stress areas also include mining in overstoped ground, such as UG2 stoping at Amplats, Impala Platinum and Northam. These are generally supported with 4m square rigid pillars or 3 metre wide pillars. Middlings between the Merensky Reef and the UG2 Reef are typically about 18 to 25 metres.

4.4.1.2 Effect of mining layout

Pillar related instability

The concerns at shallow depth with respect to gullies largely hinge around where to site a gully in relation to the chains of crush pillars, which are left in-situ between panels. From the ease of cleaning point of view the gully needs to be sited as far down dip as possible in each panel, directly along the up dip edge of the pillars, with no sidings.

Problems start to arise as pillars crush out. Observations in several Merensky Reef stopes showed that slabs bulk into the gully (Figure 4.14) as pillars crush, when no gully sidings are created. On certain platinum mines, the gully, left adjacent to pillars without any form of siding, is used only for cleaning while the panel is advancing. Men and materials enter the stope through a roped off access path in the centre of the panel, following an appropriate safe path between elongates that are used as in-panel support. Walking in the gully is generally not possible as it is kept full. In these circumstances there is no risk of injury in the gully as the panel is advanced. The only risk is during final vamping when slabs can topple into the gully. Note that most of the platinum mines claim that pillar damage on the gully edge only occurs when the gully is finally vamped, or is left partially filled by broken ore. As the gully is

finally emptied there appears to be a rapid deterioration in pillar condition, due to the removal of confinement provided by the loose rock in the gully. A full gully provides sufficient confinement to prevent, or delay, sidewall deterioration. The level of hazard created by this is, uncertain.

When pillar deterioration occurs it frequently only effects the pillar sidewalls (Figure 4.14), however, where rock strengths are relatively uniform across hangingwall, reef and footwall, damage on-reef may progress into the gully hangingwall (Figure 4.15 and Figure 4.16). Where this happens a significant hazard may be created (Figure 4.19). Loss of gully hangingwall integrity and prevention of pillars spalling into gullies and causing bulking of the down dip sidewall can only be achieved by moving the gully away from any pillar. This involves cutting a siding.



Figure 4.14 - Crush pillar directly adjacent to a gully (with no siding) is yielding in response to stope closure, resulting in slabbing being pushed, or toppling, into the gully – Merensky Reef 700 m depth

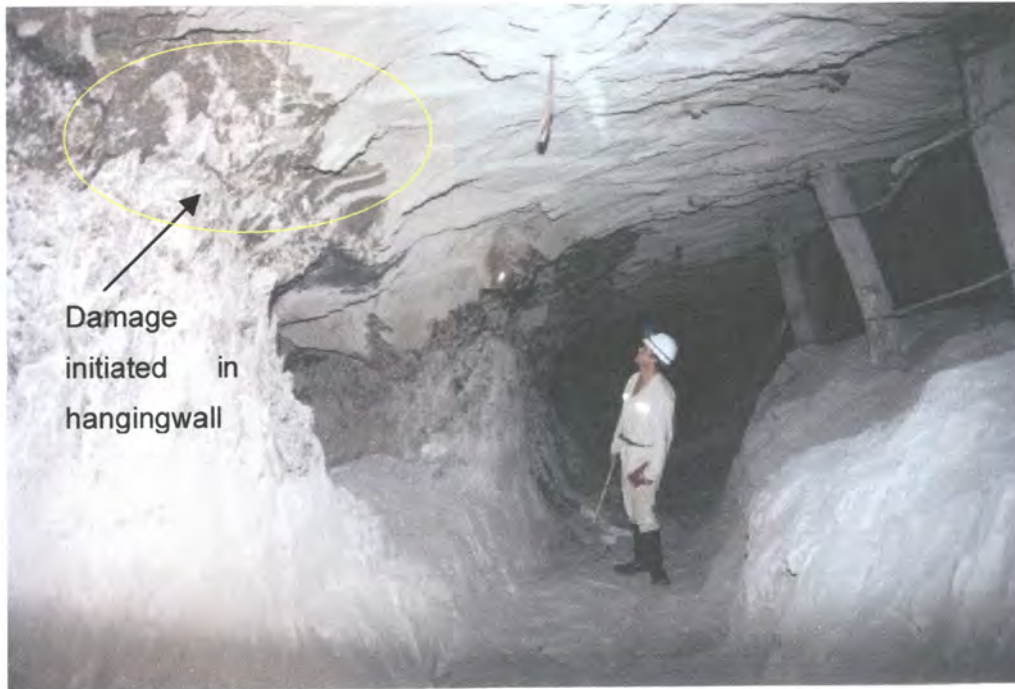

Figure 4.15 - Gully with no siding on the Merensky Reef at 800 m depth. Conditions are stable, although spalling has clearly occurred along the pillar sides. Note that pillar edge damage runs up and into the hangingwall

Siding options in use

Several variations of siding are currently used in low stress environments. It should be borne in mind that these sidings, unlike those used when mining at depth in a high stress regime, are not intended to change or manipulate stress fracture patterns. The intention is primarily to improve pillar performance, not necessarily to reduce gully hazards, as in general these are not considered problematical. If a 3 m wide pillar is inside a 1 m wide stope it has a width to height ratio of 3. If it lies on the edge of a 2 m deep gully its width to height ratio is effectively halved and the pillar yields at a lower load. By moving a pillar away from the gully edge, in theory its width can be reduced and still give the same load-bearing performance. This has ore-body recovery implications. In terms of gully stability, pillar damage is generally only seen clearly some distance back from the stope face (where the gully is empty) except in the final remnant stages.

In all gullies examined in low stress conditions, the gully was advanced as a short ASG-type heading, typically the width of the gully. Sidings, when excavated on the down dip side, fall into two categories:

1. Advanced with the ASG heading face, blasted as part of the gully round – frequently these are only 0.5 to 1 m in width and are excavated by drilling a single extra hole into the corner of the gully (Figure 4.16). This is very crude and results in a sloping sidewall from siding corner down to the gully floor. It is not supported and results in the hangingwall span from pillar to timber elongates on the up dip side of the gully being increased by 1 m. Hangingwall gully support is generally increased from rows of 3 rebars to rows of 4 rebars to cater for the increased span.
2. The siding lags the ASG gully heading, and is blasted using a series of slipping holes. The siding width generally exceeds 1 m and is generally supported by a row of timber elongates, hence minimising the span across the gully (Figures 4.17 and 4.18). Frequently, no additional hangingwall bolting is used in these circumstances.



Figure 4.16 – Merensky Reef showing a short, 0.5 m siding blasted concurrently with gully advance using a single corner hole



Figure 4.17 – Merensky Reef - lagging 1 m wide supported siding

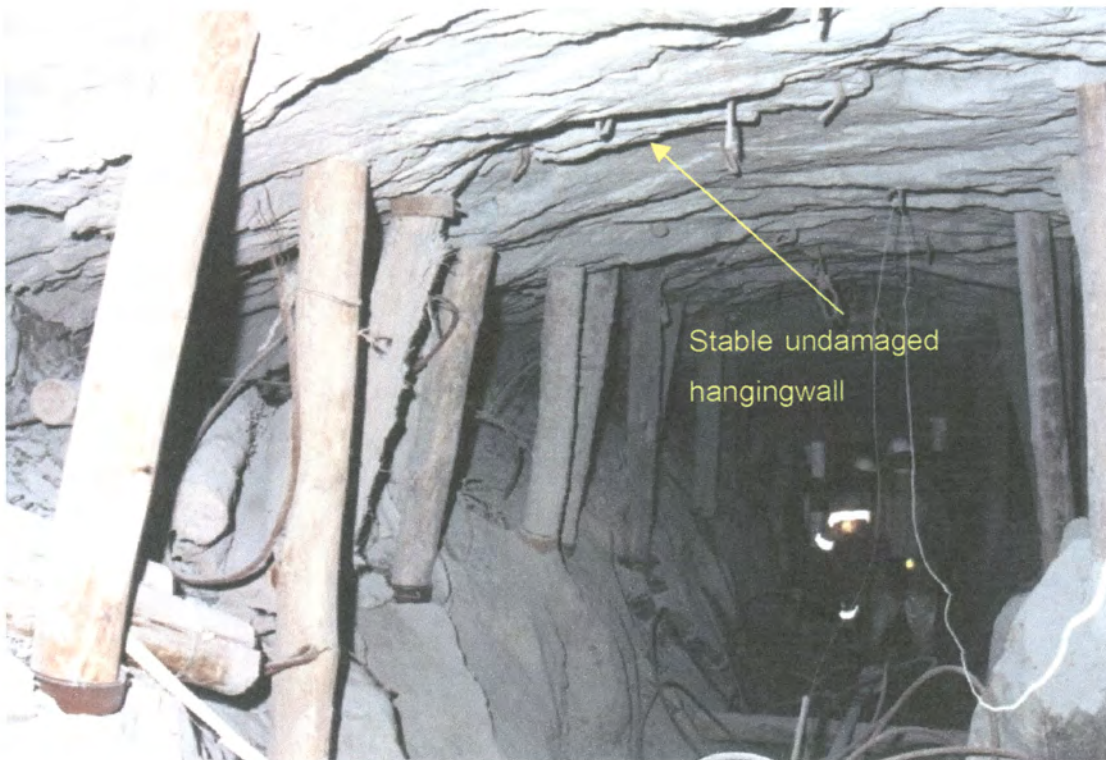

Figure 4.18 – Merensky Reef gully with 1 m siding and timber elongate providing the only support, on both sides of the gully

In terms of improving pillar performance, a siding of approximately 1 m width, even with sloping floor, appears to improve pillar behaviour based on underground observations alone. There is reduced damage in the gully sidewall, with the pillar edge generally yielding only within the confines of the siding. When the siding width is reduced to 0.5 m, sidewall damage still occurs in the gully, and, in addition, if hangingwall damage occurs during pillar crushing, the slabs which peel away still lie over the gully, presenting a fall of ground hazard (Figure 4.16).

4.4.1.3 Support practices

At shallow depth, elongates are preferred as gully edge support in the platinum mines due to their high stiffness in a low closure environment. On shallow, pillar supported gold mines such as Beatrix (Beatrix reef) and Tau Lekoa (VCR) mining without gully edge support is generally feasible.

Some mines use hangingwall bolting in addition to elongates. The practice is erratic and inconsistent from mine to mine (even where mining the same reef at similar depth) and based on local opinion. All mines make use of hangingwall bolting where no elongates, or other gully edge support, is used.

In general poor ground conditions which arise due to geological structure are handled by leaving additional in-stope pillars and reducing spans, rather than by using installed support. Where poor conditions in gullies arise from damage associated with crush pillars, additional support is used such as bolting or meshing and lacing (Figure 4.19).



Figure 4.19 - Merensky Reef gully where a crush pillar lies on the gully edge and during crushing has damaged the hangingwall resulting in mesh and lacing application to control minor falls

4.4.1.4 Geotechnical conditions

A broad depth region exists where stress fracturing around excavations starts to influence stability. Stress fractures interact with geological features to create potentially unstable wedges of ground along gullies. Rock mass behaviour under moderate stress remains strongly influenced by local geology and in particular the stratigraphic sequence in the immediate reef hangingwall and footwall.

One extreme in terms of conditions would be well bedded and jointed quartzitic strata where cross bedding, argillaceous partings and shale layers in the hangingwall dictate a tolerable limitation to stable spans across gullies. The other extreme would be cases such as the Merensky Reef and VCR where massive pyroxenite or lava are very competent as hangingwall surfaces and design issues relate mainly to stress induced damage in weaker footwall strata and the influence on gully shoulder stability. In the former case, stress induced fracturing interacts with bedding to cause instability and stress may even drive movement on bedding. In the latter case stress fractures develop in the massive rock mass, but rarely interact to create hangingwall instability.

It is this dual consideration of stress and stratigraphy that dictates the choice of gully practice: stress alone does not appear to be the deciding factor.

4.4.1.5 Effect of mining layout

All types of gully were observed under moderate stress conditions, from ASG's with no sidings to footwall lifted types in wide headings. From the gullies which were inspected a number of cases are discussed in detail, which reflect the influence of geotechnical conditions on gully design under moderate stress.

Massive rock mass conditions

Examining competent, massive, rock mass conditions first, observations made on the Merensky Reef at Northam platinum mine provide a particularly useful case study. Gullies with no sidings, with Sags and lagging sidings and footwall lifted gullies within wide headings could all be observed at similar depth (1800 to 2000 m) on the same reef, and as near as possible within the confines of one mine, under a similarly oriented in-situ stress regime. Dip was generally 18 degrees. In this area the Merensky Reef has a competent pyroxenite hangingwall, but may have a weaker anorthositic footwall. Two sets of well defined steep dipping joints occur in the area examined: one set parallel to dip, typically with a 10 cm average spacing, the second set trending 020 degrees with an average 50 cm spacing. Where the rock mass is massive, and generally not jointed, tendons are not installed in the hangingwall.

ASG type gullies without sidings showed variable degrees of damage on the solid, downdip side (Figure 4.20). Where mined span from the centre raise was short, stress fracturing was not severe, extending some 1 m into the sidewall, but, even 10

m off the ledge, starting to show a loss of 30–40 cm of material from the sidewall and the generation of an overall curved shape to the sidewall. Mining practice was to minimise gully height (2.9 m maximum was measured) to reduce this scaling. Distance across the gully was measured up to 2.25 m, well in excess of the 1.8 m standard, and the updip gully shoulder was low and broken back. The overall impression was that while the sidewalls spalled, the hangingwall remained stable and largely undamaged. Sidewall damage became progressively worse with distance from the initial raise (Figure 4.20).

Where sidings were created lagging behind the gully face there appeared to be little improvement in gully shoulder and sidewall conditions, if the footwall was anorthosite and weaker than the pyroxenite hangingwall. Gully width varied from 1.8 m to 2.7 m, frequently outside standard. Fracturing in the shoulders develops around the ASG face and trends near-parallel to the gully. Gully sidewalls had spalled on both sides, resulting in sloping surfaces on which packs were frequently positioned. The ledge on the down dip side was generally cut with a horizontal footwall, rather than parallel to reef. In the main, packs were constructed vertically, between non-parallel hanging and footwall surfaces, with the result that odd bits of timber packing are used and packs buckle and appear ready to be squeezed out. Packs were of 75 cm size, up to 2 m high, i.e. an excessive, and non-standard, width to height ratio. Again while poor sidewall conditions threatened pack stability, the hangingwall conditions were good (Figure 4.21).



Figure 4.20 - Merensky Reef - no siding. Severe spalling down dip



Figure 4.21 - Gully with lagging siding. Down dip siding has a flat floor due to stress fracture damage. Down dip packs are vertical

Two cases were examined where gullies had been footwall lifted within wide headings. It was observed that the gully walls were clearly vertical, and stable, with stress fractures trending perpendicular to gully walls. These developed ahead of, and parallel to, the face of the headings, which on average were 7.5 m wide and advanced approximately 13 m ahead of the stope panel face. Hangingwall stress fracturing only appeared dense near a point where the gully configuration was changed from an ASG to a wide heading, clearly curving, in plan, across the gully around the past stope face corner position due to the previous lagging siding. The hangingwall was stable, as in all observed cases. Packs in these heading gullies were installed perpendicular to dip, between parallel hangingwall and footwall surfaces, as shown in Figure 4.22. General conditions in a wide heading are shown in Figure 4.23.

One heading was observed in near-remnant conditions, where stresses were elevated above typical values for 1800 m depth and the stress fracturing in gully shoulders was more dense. Although still normal to the gully direction, this increased density of fracturing caused gully shoulders to be less square and strong than observed elsewhere. Also the footwall of the down dip ledge appeared to have been cut horizontal rather than parallel to dip, resulting in a less stable pack construction. Span between support across these gullies was typically 1.7 m, within standards.

Two gullies were examined where the mining configuration was overhand and gullies were footwall lifted within the top area of the leading stope panel (Figure 4.24). Stress fractures observed in the anorthosite reef footwall along the gully had developed parallel to the original stope panel face, and hence were trending perpendicular to the gully walls, dipping at 50 to 60 degrees back from the face, and spaced 10-25 cm apart on average. Steep jointing trending 020 degrees contributed to wedge failure in the updip gully sidewall. Stress fractures were less well developed in the hangingwall. Spacing between 75 cm packs across the gully was typically 1.8 m and 1.75 m apart along strike, within standard.

In general, ASG-type gullies appeared to lead to poor gully sidewall conditions, resulting in poor pack integrity. Gullies that were footwall lifted gave improved shoulder conditions. In all cases, the hangingwall, being the stronger rock type, fractured less than the footwall and was generally stable, except where ASG-type gullies had not advanced for some period of time.



Figure 4.22 – Merensky Reef - footwall lifted gully in wide heading. Due to down dip sidewall integrity, all packs are normal to dip



Figure 4.23 - Merensky Reef - conditions in a wide heading with footwall lifted gully



Figure 4.24 – Conditions along a footwall lifted gully on the Merensky Reef. Note backfill installed on the down dip side

Bedded rock mass conditions

In the Free State, gullies on the Basal Reef at Bambanani and St. Helena mines and the Kalkoenskrans reef at Oryx mine provided a similar range in cases, illustrating the change in rock mass behaviour when the rockmass comprises bedded quartzitic strata with argillaceous partings. The Basal Reef is overlain by the Waxy Brown quartzites, with varying degrees of competency at the base of which the Khaki shales are locally present. In places the upper part of the Basal Reef is left insitu (where the reef is thick) to prevent the collapse of overlying weak strata. The mining depths examined ranged from approximately 1700 m to 2500 m, conditions where normally severe stress levels and associated fracturing could be expected. On the Basal Reef, the Bambanani panels had an average dip of 35-40 degrees, and as a result standards where no siding is cut were enforced. At this dip mining personnel consider siding cutting and cleaning to be particularly difficult, as the siding tends to sit in the gully floor. The range in gully types included ASG-type gullies either without sidings or with lagging sidings. Hangingwall bolting appears to be an essential part of ensuring gully hangingwall stability where the hangingwall strata is well bedded.

Where an ASG is cut ahead of the stope face (typically leading by 2 m), and stress fracturing was observed to develop in the immediate sidewalls, parallel to the gully and, extend some distance over the gully, truncating on bedding surfaces. The result is that a combination of bedding and stress fractures developed immediately around the ASG heading give rise to unstable blocks in both the gully hangingwall and sidewalls (Figure 4.25). These fractured blocks lie within the span between packs across the gully and if poorly supported by tendons the hangingwall may break out through any quartzite beam and possibly run away if the Khaki shale or Waxy Brown quartzite is particularly weak (Figure 4.26). Similar phenomena are seen in relation to the Green Bar on the Carbon Leader Reef in the West Rand area.

Where a lagging siding is cut, a further set of stress induced fractures are created. These trend diagonally to the direction of gully advance and have a flat dip, curving back over the gully hangingwall into the bedding and forming slabs over the gully and siding (Figure 4.27).

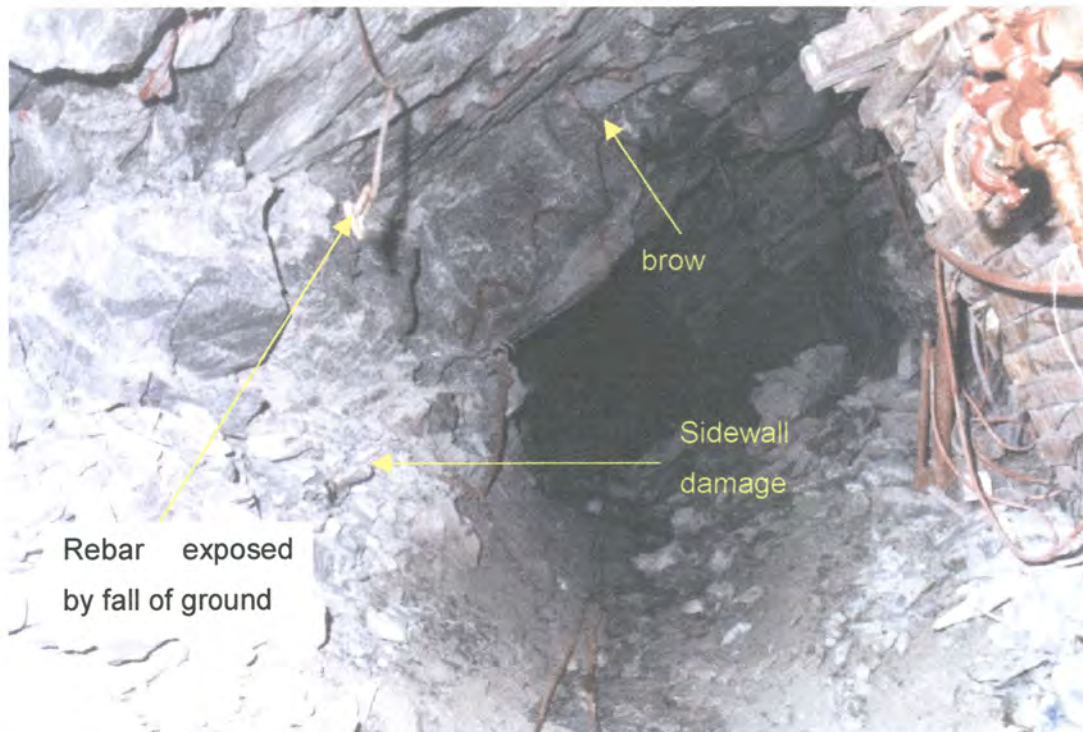

Figure 4.25 - Basal Reef - gully excavated at 2500m with no siding with stress damage causing down dip sidewall and hangingwall instability at 40° dip

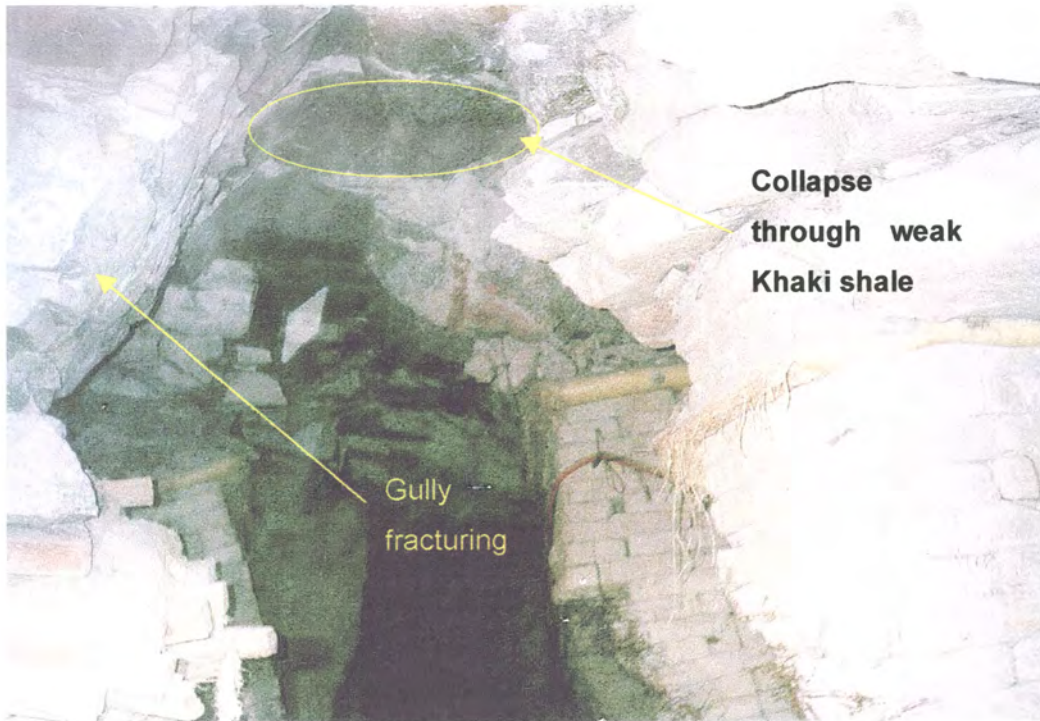

Figure 4.26 - Basal Reef – collapse of gully hangingwall due to fracturing developed around leading ASG heading at 1600m below surface



Figure 4.27 - Basal Reef – the effect of a lagging siding on hangingwall conditions – view from face area looking back along gully at 1700m

In general, where the gully geometry includes an ASG ahead of the stope face with a siding lagging behind the face, the combined effects of gully parallel fractures, plus diagonal, flattening dipping fractures due to the siding are seen. Typical results in well bedded strata are illustrated in Figure 4.28. Gully sidewalls break back, creating poor pack foundations, and packs end up being widely spaced across the gully. This increased span provides poor support for the broken, slabbed and bedded hangingwall. Another concern is that as the dip increases, the presence of steep dipping footwall bedding in addition to gully parallel fracturing makes the up dip gully shoulder less stable with the result that pack foundations are frequently lost.

In general, damage along gullies tended to result in brows on the up dip side of the gully which progressively broke back into the stope resulting in poor in-stope conditions. Frequently falls of ground over gullies appeared to be initiated at the bottom of the stope panel face where large unsupported spans exist across the gully due, in part, to the distance packs are installed from the stope face.

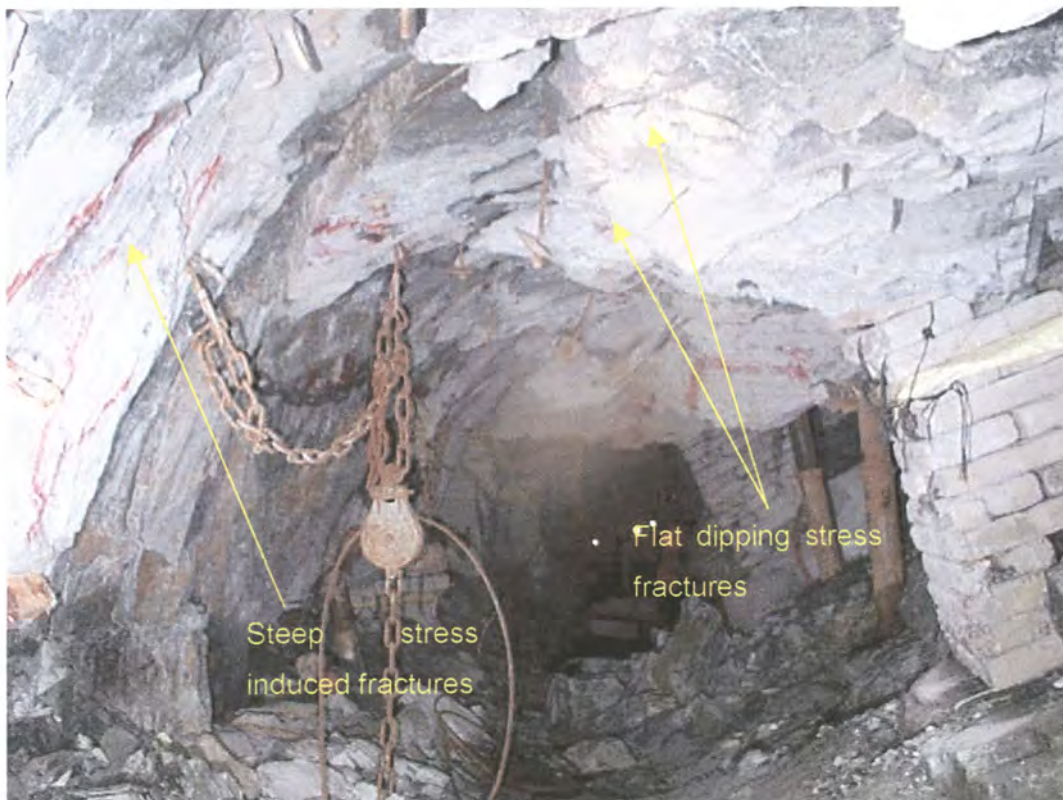

Figure 4.28 - Basal Reef - combined effect of an ASG heading, plus a lagging siding when strata is well bedded at 1700m below surface

Opinion on these mines with well bedded hangingwall strata is that a preferred layout would involve cutting the stope face, gully and siding all in line, with a siding extending 3 m down dip from the gully. In general this appears to be a distance that ensures the gully is away from any curved or flat dipping fracturing that develops around the down dip corner of the siding. All stress fracturing at the gully position would be parallel to the stope face and hence perpendicular to the gully direction and therefore easier to support.

4.4.1.6 Support practices

Support practises and requirements under moderate stress conditions are influenced by local geology. In all cases where any stress damage is apparent packs become the preferred method of support along gully edges, because they are more stable and have better areal coverage than elongates

Where the hangingwall is bedded tendons are required in the span across the gully between packs. This is not a prerequisite on Bushveld reefs such as the Merensky Reef where the hangingwall consists of a relatively massive pyroxenite.

To be effective, tendons should be installed as near as possible to 90 degrees to the dip of the strata. The span between the packs across the gully should not exceed 2.0m when normal scraper cleaning is used. The minimum length of tendon required appears to be 1.5m based on heights of hangingwall falls in well bedded quartzites.

Due to a tendency towards poor ground conditions in well bedded rock as a result of the use of inappropriate layouts, a range of remedial measures were observed including injection grouting, immediately active tendons such as split sets, umbrella packs and sets with cribbing.

4.4.2 High stress conditions

High stress conditions covers those cases where stress fracturing provides the dominant discontinuity that controls gully stability. Underground observations indicate that manipulation of stress fracture patterns becomes essential to ensure competent ground conditions. Local geology determines behaviour and extent of collapse once control is lost and major falls occur. High stress cases that were examined included workings on the VCR (at Mponeng, Savuka, Kloof and Deelkraal),

Carbon Leader (Savuka, Tautona and West Driefontein), and the Vaal Reef (Hartebeestefontein).

4.4.2.1 Geotechnical conditions

The in-situ stress level, resulting from depth or remnant conditions, coupled with the strength of the rock mass influences the degree of stress induced fracturing. Where stresses are sufficiently high that stress fractures form at a density of 20 or more per metre, they become the controlling factor in overall gully hangingwall and sidewall stability. Bedding and the presence of argillaceous partings may locally affect stress fracture orientation. In general the main factor that influences stress fracture orientation is the geometry of the excavation. An example of the typical fracture density in competent strata is shown in Figure 4.29. Between 2600 m to 2800 m below surface, fracture densities are 15 to 20 fractures per metre in the lava compared to 20 to 30 fractures per metre in quartzite. Local geology, such as bedding, jointing, faulting, and the presence of weaker stratigraphic units all add to the potential for instability. In all the cases reef dip was approximately 20 degrees.

A feature of deep, high stress conditions is the occurrence of seismic activity. Gullies frequently need to be kept open along solid mining abutments, for example updip of stabilising pillars in longwall layouts. Large seismic events may consequently occur in close proximity to gullies.

4.4.2.2 Effect of mining layout

After inspecting a number of highly stressed sites it was apparent that while it is recognised that gullies should be placed away from abutments and that sidings are necessary under high stress conditions, inappropriate methods of gully layout are still used. This is particularly the case on mines working the VCR, where the hangingwall is often competent, exceptionally strong Alberton Formation Lava with a uniaxial compressive strength in excess of 350 MPa. While these lavas may be jointed, reef-parallel partings, or flow bedding, are few. Consequently, under moderate stress conditions there is little lava damage and attempts are made to use ASG-type headings to greater depths and higher stress levels than are attempted with more quartzitic and well-bedded strata.

Under high stress conditions, ASG-type gullies with lagging sidings, wide heading gullies and overhand panel layouts with footwall lifted gullies in the top of the panels were all examined.



Figure 4.29 - Typical high density stress fracturing in gully sidewalls in VCR footwall quartzites

ASG type gullies with lagging sidings

ASG-type gullies with lagging sidings were examined on the VCR, at 2000 m to 2800 m depth, and on the Vaal Reef in a shaft pillar remnant at 2300 m depth. In all cases conditions were poor and considerable damage had occurred. Typical conditions are shown in Figure 4.30.

In all the high stress areas visited, ASG headings are carried no further than 2 m ahead of the stope face, and, due to the increased level of stress the heading barely extends beyond the stress fracture zone that develops ahead of the stope face. As a result stress fractures do not form parallel to the ASG heading sidewalls but tend to curve around the heading and back towards the lagging siding, flattening in the lead area. These low angle (30-40 degree) fractures incline from the down dip edge of the gully over the stope. As the siding is excavated these fractures are exposed and curved slabs tend to spall away from the hangingwall, prior to installing packs in the

siding, giving rise to a general arched shape. Fracturing tends to result in non-parallel hangingwall and footwall surfaces in the siding leading to poor pack construction practices - these packs are easily pushed into the gully by stress fracturing in the siding, or may be forcibly ejected by seismicity.

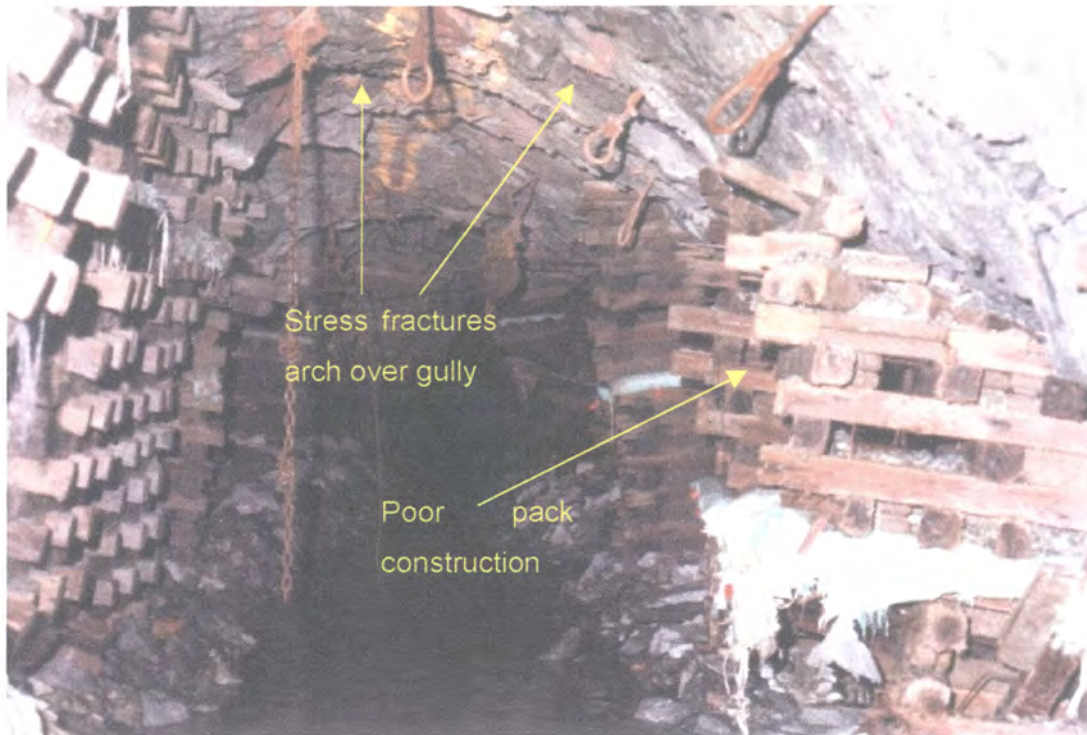
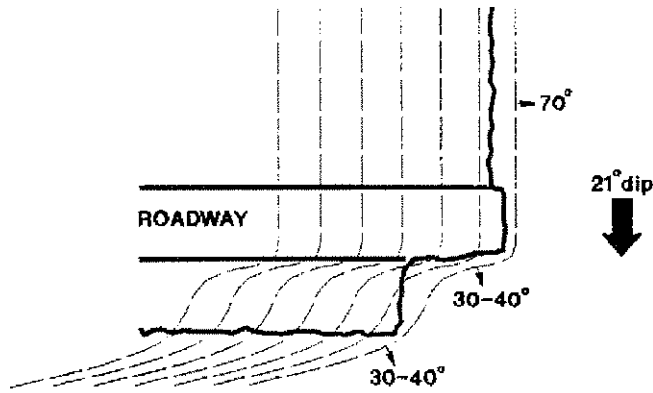
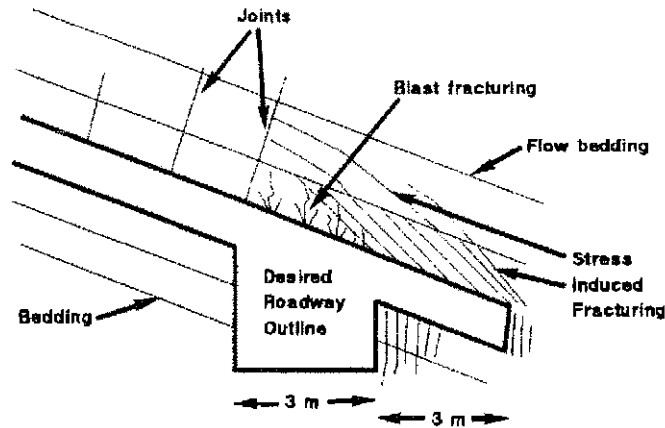

Figure 4.30 - VCR under high stress – Gully advanced as an ASG with lagging siding at 2800 m depth

On the VCR, the interaction of these low inclination stress fractures with joints and flow bedding planes results in the creation of wedges of ground that may be several metres thick. A sketch diagram that illustrates this, based on observations in a 3 m wide reef drive, or trackless roadway, is shown in Figure 4.31. An example of a relatively minor wedge-shaped fall is shown in Figure 4.32.



(a) Sketch plan showing typical current roadway layout and fracture pattern



(b) Sketch section illustrating the desired roadway geometry

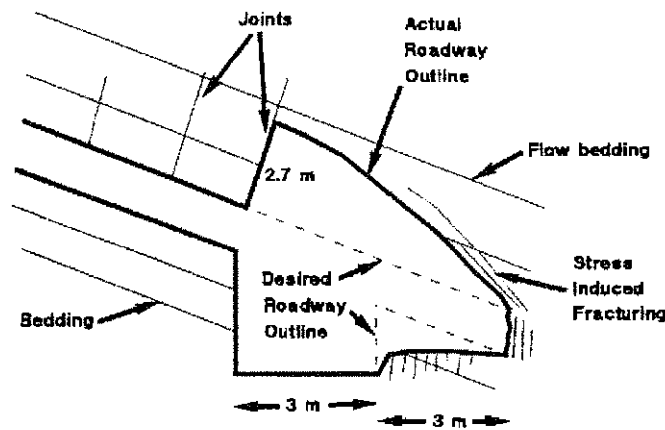

(c) Typical roadway shape which arises from fracturing and falls at the face

Figure 4.31 - Typical VCR gully damage resulting from the use of an ASG with a lagging siding under high stress conditions

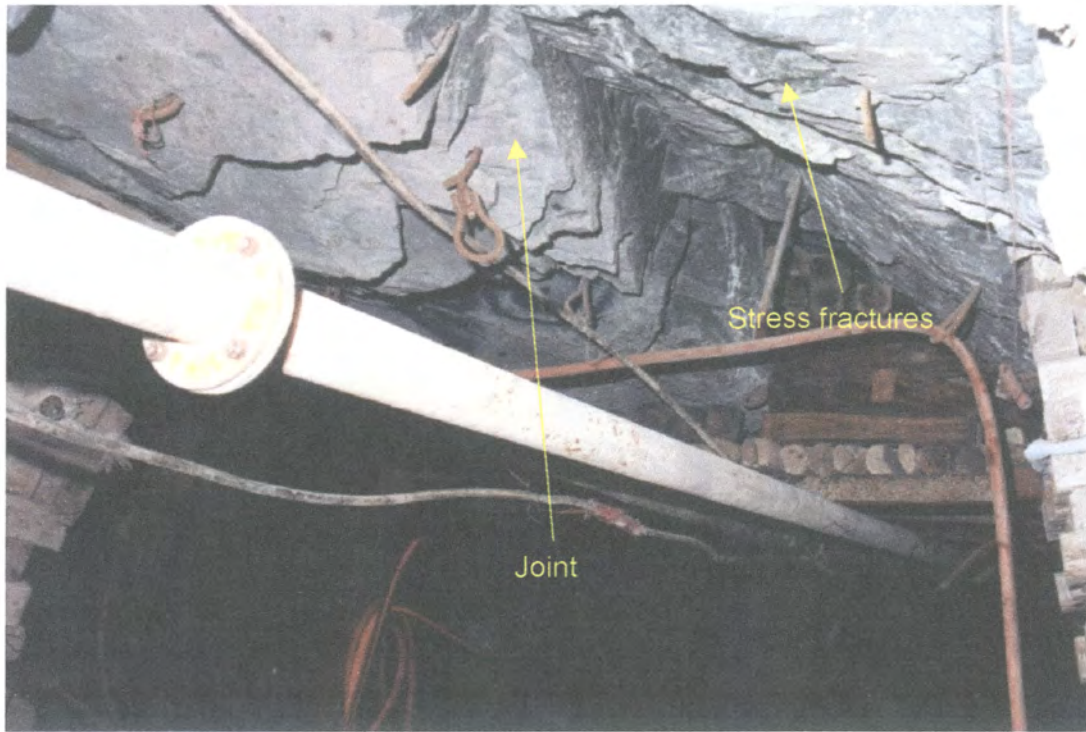

Figure 4.32 – Typical wedge shaped fall caused by the interaction of jointing and stress fracturing around a lagging siding on the VCR

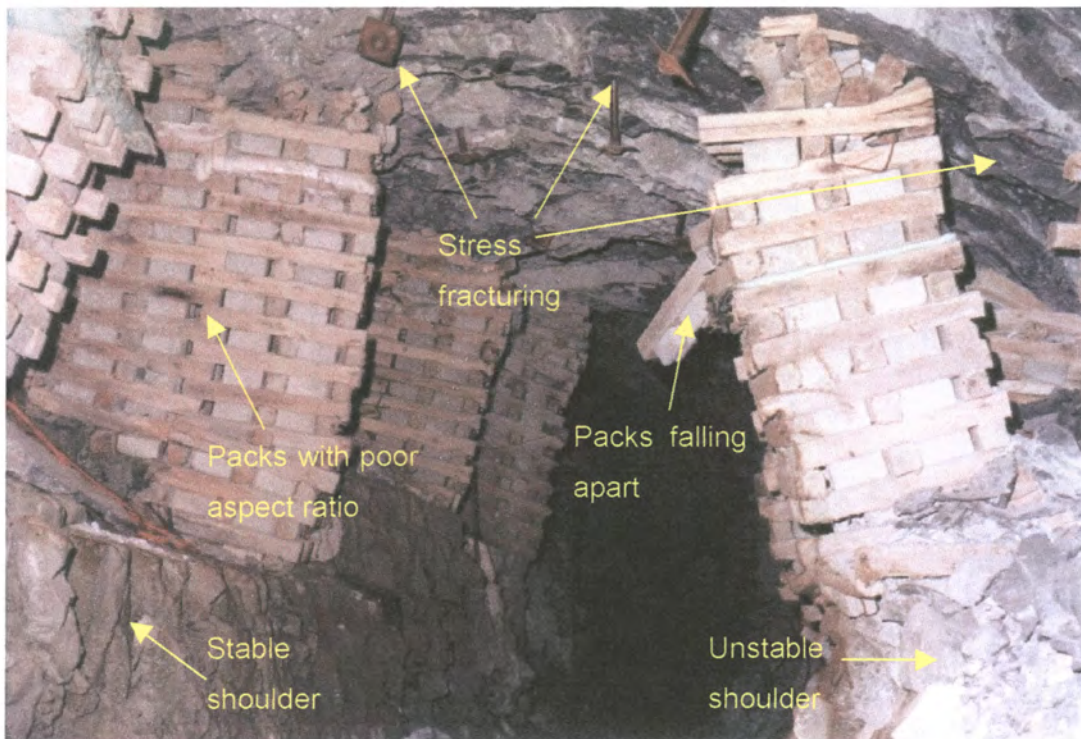

Figure 4.33 – VCR - Typical conditions that may develop along a gully created as an ASG with lagging siding under high stress

It should be noted that the 2 m lead on the ASG heading does not necessarily result in adverse fracturing in the up dip gully wall, because of the distance that face-parallel fractures develop ahead of the stope face. These are generally perpendicular to the up dip gully wall and do not destabilise it (Figure 4.33). Thus pack construction on the up dip side of the gully can be good and normal to dip. However, the down dip gully shoulder is generally not so stable. Overall, when a lagging siding is cut under high stress conditions hangingwall falls occur, the gully hangingwall tends to break out well above the reef contact, and unstable packs with excessive height to width ratios result. Seismic activity readily dislodges these packs leading to further falls, and an ever worsening state. Figure 4.33 illustrates the general condition that arise.

Blasting practice, where the ASG heading is developed leads to additional fracturing in the immediate gully hangingwall. As a general comment, any form of gully where a narrow ASG is advanced and a lagging siding is used would appear to be completely inappropriate for deep, high stressed, mining conditions.

Wide headings and footwall lifted gullies

Wide headings with gullies excavated within them by footwall lifting were observed under high stress conditions on the Carbon Leader reef and VCR at depths from 2000 m (shaft pillar remnant) to 3200 m. Wide headings were examined in two situations. First, the overhand method requires that only the bottom gully of the raiseline or longwall uses this method. It lies adjacent to a long term abutment or stabilising pillar and consequently deterioration occurs over time. Secondly, underhand mining layouts require that all stope gullies in the raiseline or longwall have wide headings.

Typical conditions that result along gullies excavated using this method are shown in Figure 4.34 and 4.35. Hangingwall conditions observed appeared generally sound. Heading widths observed ranged from 4.2 m to 10 m. In all cases gully width was of the order of 1.8 m. In the narrower width heading there was some tendency for curvature of the stress induced fracturing in the gully shoulders. At 10 m width, fracturing was parallel to dip and perpendicular to the gully direction well into the shoulders and away from the gully. Heading leads varied from 3.5 m to 10 m. The longer lead was associated with the wider headings, and it appeared that wider headings were used to permit a longer lead to be tolerated and move gully-parallel fractures well back from the gully shoulders.

Frequently, sidings tend to be excavated flat, cutting across bedding and damaging the hangingwall strata. On reefs such as the Carbon Leader where a quartzite middling is present between the reef and a weak shale, this damage to the hangingwall can prove critical to long term gully stability. In an underhand mining layout the damage done by mining the siding off reef can cause severe ground control problems in the panel below.

As a comment, gullies advanced in a wide heading in a deep mining situation are often associated with poor conditions and develop a bad reputation in the minds of mining personnel. This can be largely attributable not to any inadequacy in design, but to firstly the labour intensive nature of mining a heading and siding, and secondly that these gullies are frequently positioned alongside the edges of pillars. In this position they suffer stress damage due to the proximity of the abutment coupled with seismic damage.



Figure 4.34 - Carbon Leader wide heading footwall lifted gully with good hangingwall conditions at 3200 m depth

Overhand mining layouts with footwall lifted gullies in panels

When an overhand mining layout is used, gullies can be excavated by footwall lifting in the top corner of each panel. This is a preferred method in deep level mining as it does not require headings, complex blasting, or difficult cleaning. It also leads to solid gully sidewalls if the gully is sited correctly.

This type of gully was examined under high stress conditions on the Carbon Leader Reef at 2500 m to 3200 m depth, and the VCR at 2000 m to 3000 m. VCR cases included strong Alberton Formation hangingwall Lavas, weak Westonaria Formation (WAF) lavas and a situation where a quartzite beam separates the reef and overlying lava.

The gully in this case is used as a top escapeway for the leading panel and for cleaning the panel up dip, which lags. In many instances the gully is only lifted just ahead of the face of the lagging panel, however, in mines where seismicity is severe the importance of getting the escapeway at full gully depth, close to the face of the leading panel is recognised. In general a survey centre line for the gully is laid out in the stope and gully edge packs are installed either side of this line at the face of the leading panel. The gully is advanced between these previously installed packs. The influence of blasting technique on the stability of these gullies is discussed in section 5.6.

The main critical aspect regarding the design geometry of this type of gully is the position the gully is placed relative to the strike abutment between the leading and lagging panel faces. This distance must be such that the gully lies in a position where stress fractures are parallel to the leading panel face and are not curved due to the proximity to the corner of the panel. Fracture dip however may be as flat as 30 degrees, dipping towards the panel face.

Deep level mine standards typically require the gully centreline to be 4 m from the top of the leading panel giving a distance of at least 3 m to the edge of the gully. As a generalisation, at this distance hangingwall fractures are generally face-parallel while some fracture curvature is exposed in the updip gully sidewalls when gully depth exceeds 1.5 m below reef. In general gully sidewalls can be cut to be vertical and stable.

Hangingwall stability over footwall lifted gullies appears to be a function of the density of fracturing that forms around the stope face ahead, coupled with local geology. Conditions can be extremely good (Figure 4.35).



Figure 4. 35 - VCR footwall lifted gully – good hangingwall conditions

Where the density of stress fractures is fairly high (10 to 20 fractures per metre) hangingwall conditions over these footwall lifted gullies are generally reasonably competent when spans between packs across the gully are approximately 1.5 to 2 metres. Problems only arise when cubbies have to be opened up for face winches or for water-jet pumps. Typically packs have to be removed alongside the gully to create the cubby, and on the Carbon Leader reef this may trigger the collapse of the quartzite middling below the Green Bar.

Despite correct siting of a footwall lifted gully, stable conditions may not be guaranteed. This is not a design flaw, but merely the result of the general reaction of weak ground to high stress. Where the degree of stress fracturing around the stope panel face is intense (20 or more fractures per metre), the hangingwall may start to collapse in the stope face area prior to gully pack installation. Under these circumstances maintenance of stable gully conditions appears virtually impossible. Such were the conditions in Carbon Leader panels where the quartzite middling below the Green Bar is 1 to 2 m, and on the VCR where WAF lavas occur. In these

conditions, even a 1 m spacing between support across the gully fails to prevent ongoing falls. It is imperative to install packs close to the face of the leading panel and to keep the footwall lifting close behind these packs so that hangingwall tendons can be installed as early as possible. In many instances deterioration is aided by seismic shakedown. One problem in areas where high falls occur is that access to the hangingwall is often difficult to install replacement tendons. Remedial support is required.

4.4.2.3 Seismic damage in gullies

Under high stress conditions seismicity contributes greatly to deterioration in gully conditions. Due to the fracture patterns associated with sidings and headings, gullies frequently prove more prone to seismic damage than stope areas. The nature of damage is generally similar in many cases:

- Collapses at the face prior to cutting and supporting the siding.
- Falls of ground back along the gully, often running from the face for many metres into the back area, where fragmented rock falls from around tendons. Except where the collapse occurs up to a high and well-defined parting (as shown in Figure 4.36), the tendons rarely snap and frequently few packs are dislodged although hangingwall falls may be in excess of a metre in height.
- Where there is solid ground a short distance down dip of the gully, packs built in sidings get ejected into the gully, often aided by poor siding geometry (In the example shown in Figure 4.37 packs have been destroyed on a VCR reef drive, leading to extensive hangingwall collapse).
- Collapse of gully sidewalls due to sudden increased pack loading.

A point to note about all these areas of damage is that falls depend on pre-existing damage, or geological structure. Hence minimisation of seismically induced falls largely depends upon adopting gully design layouts that minimise stress damage and fracturing, or orientate fractures into directions where they prove easiest to support. An important issue is an apparent tendency for face bursting to occur more readily where face height is increased. Thus at depth, face bursting occurs more readily in full-height ASG headings than in the adjacent narrower stopes. This type of occurrence counts against the use of anything other than wide headings and footwall lifted gullies under high stress conditions.

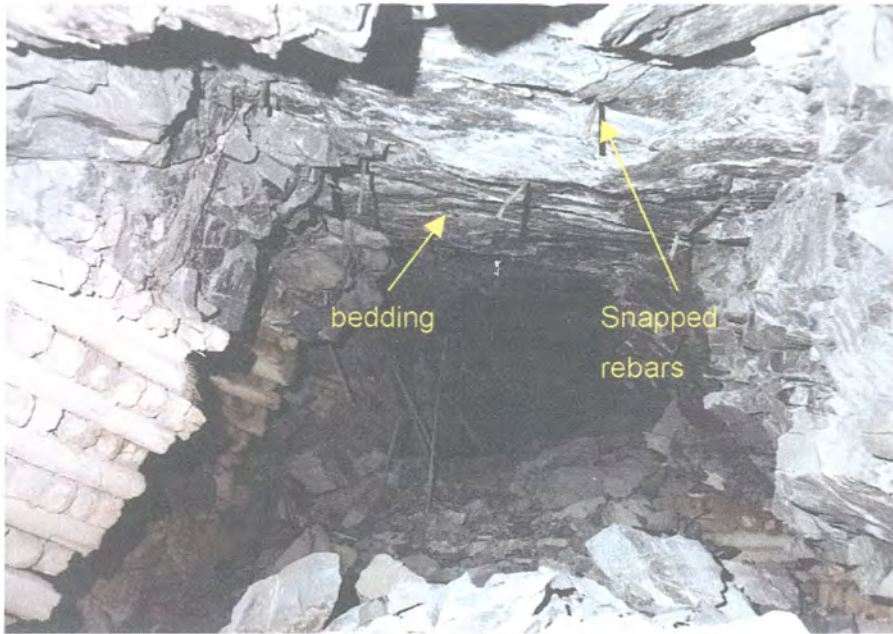

Figure 4.36 - Collapse back along a gully as a result of seismic activity. The hangingwall has collapsed between packs up to a bedding parting. Rebars are snapped or exposed

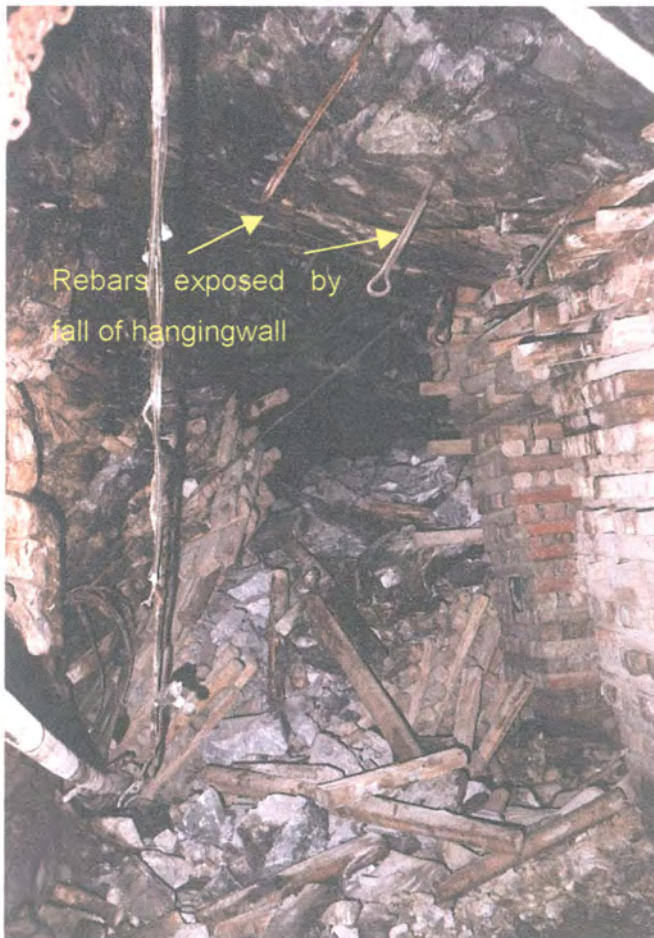

Figure 4.37 - Collapse of a reef drive on the VCR horizon due to ejection of packs from the siding by a seismic event

4.4.2.4 Support practices in high stress areas

Basic support

High closure rates in stopes are typically associated with high stress conditions, and in almost all the cases examined gully support comprised both hangingwall tendons and packs along the gully edges.

Preference is given to long axis packs that are at least 1.1 m long in the dip direction, while strike length is commonly 75 cm. These are long enough to remain stable even if some gully wall instability causes partial loss of pack foundations. Pack types in use were mainly relatively stiff timber end-grain units such as Hercules and Apollo packs. Brick composites and solid timber mats were also used. Except where inappropriate ASG geometries with lagging sidings were used, these stiff packs did not appear to have a visible detrimental effect on gully wall stability. In many of the high stress back areas that were visited, the stope closure was near total and resulted in complete compression of gully packs, except where falls had occurred, locally increasing stope height around the gully area.

Where backfill is in use, experiments at Savuka mine indicate that it is practical to eliminate pack support and carry classified tailings fill to the gully edge, using elongates as gully edge support until the backfill becomes loaded.

The tendons observed as standard basic support included 1.2 m split sets and 1.5 m grouted rebars. End anchored bolts without grout is generally not used in high stress conditions. Split sets are particularly popular, as they are immediately active upon installation and appear capable of accommodating shear deformation, but may slip in their holes.

Remedial and special support measures

Due to high density stress induced fracturing there are many situations where gully conditions deteriorate rapidly, despite all attempts made to minimise adverse fracture orientations by using footwall lifting methods to advance gullies. In general, once a gully hangingwall starts to break up in this environment, the collapse tends to run for considerable heights into the hangingwall. This is particularly the case on the Carbon Leader Reef, and the VCR where weak WAF Lava is present.

Preventative measures: area coverage

Where gully collapse is anticipated some form of total area coverage can be applied to the hangingwall. This can comprise strapping between bolts, which is preferable to mesh due to durability. Alternatively shotcrete has been used successfully. In some instances, where the hangingwall is considered too weak to adequately support with tendons, sets and cribbing are built into packs as the gully is advanced.

A favoured method of providing total area cover for WAF lava areas is the gully liner. This is a steel sheet arch that rests on an angle-iron fixed to the packs on either side of the gully. Liner arches are placed skin to skin along the gully completely covering the hangingwall. Each liner comprises two arched plates that slide inside each other enabling the arch size to be adjusted to fit the actual distance across the gully. The space above each liner, up to the hangingwall is packed using a grout-filled pack-prestressing bag, pumped sufficiently to fill the void. These appear reasonably successful as a means of stabilising the gully hangingwall. A design flaw however appears to be the way the liner rests on the angle-iron support. Movement in the packs or across the gully appears capable of dislodging the liner from its support.

Another method of providing total area coverage, while the gully hangingwall remains relatively intact, is the use of trusses and cribbing. Trusses consist of two cables, installed in separate holes, which are tensioned against each other and provide confinement to the rock mass between the two anchorage points. In gullies, trusses can be installed such that the holes are drilled over pack positions on either side of the gully. A series of trusses along the gully can be used to hold timber cribbing against the hangingwall. An example, photographed on the VCR horizon during the early 1990's, is shown in Figures 4.38 and 4.39. The first figure shows the trusses and cribbing immediately after installation. They are in the hangingwall of a 3 m wide on-reef trackless roadway. Trusses are installed across the gully while cribbing is installed along it (or parallel to it). An advantage of this situation is that height was available to drill correctly angled holes for the trusses. Normal gullies tend to be more confined. Figure 4.39 shows, for comparative purposes, the condition of the roadway after a nearby magnitude 3 event. While packs have collapsed along the roadway sidewalls, the hangingwall has remained relatively intact, and firmly controlled by the trusses.



Figure 4.38 – On-reef trackless roadway supported with trusses and cribbing (before rockburst)



Figure 4.39 – Roadway after seismic damage – packs collapsed, trusses and hangingwall intact (after rockburst)

Injection grouting

Where the hangingwall breaks out to a relatively stable surface, that can be drilled, the ground can be consolidated by injecting resin-based or cementitious grouts into fractures. A number of sites were examined where this had been attempted with varying degrees of success.

In general, the method combines bolting and injection, where bolts with hollow centres are used to inject the grout. Both purpose-designed hollow bolts, and split sets have been used. Grout injection via split sets appears unreliable however. Large washers are generally used in conjunction with the bolts to provide support and confinement on the hangingwall surface. Examples are shown in Figures 4.40 and 4.41.

Normal practice is to drill a pattern of holes in the area requiring rehabilitation, install the bolts and inject grout until it is seen emerging from any nearby fractures, or until any resistive pressure to grout injection is built up.

The method has also been applied preventatively. Sites were inspected on the Carbon Leader reef where, because of planned removal of packs to create a cubby, a potential fall of hangingwall had been anticipated. Resin had been injected through nine split sets, however in one case the collapse still occurred. In this case it was noted that there was poor resin penetration of fractures. Split sets remained in place in the hangingwall with rock slabs glued to them, the remaining material between the bolts having fallen out.

Void filling

When the collapsed hangingwall over a gully is too high to be accessible, or too loose to safely drill, the use of sets and void filling becomes an effective, though expensive, means of providing a safe access along the gully.

Steel pipe, steel girders, or heavy timbers are placed across the gully, between packs. A capping of timber slabs is placed on these sets. On top of this a geofabric bag is placed and filled with foamed cement. Practice indicates that this needs to be a minimum of 0.5 m thick, but need not totally fill the void. Several of the deepest mines use this method routinely and long term stability has been achieved in a number of highly damaged gullies.



Figure 4.40 – Ground consolidation by injection grouting in the partially collapsed hangingwall of a VCR strike gully at 2800 m depth

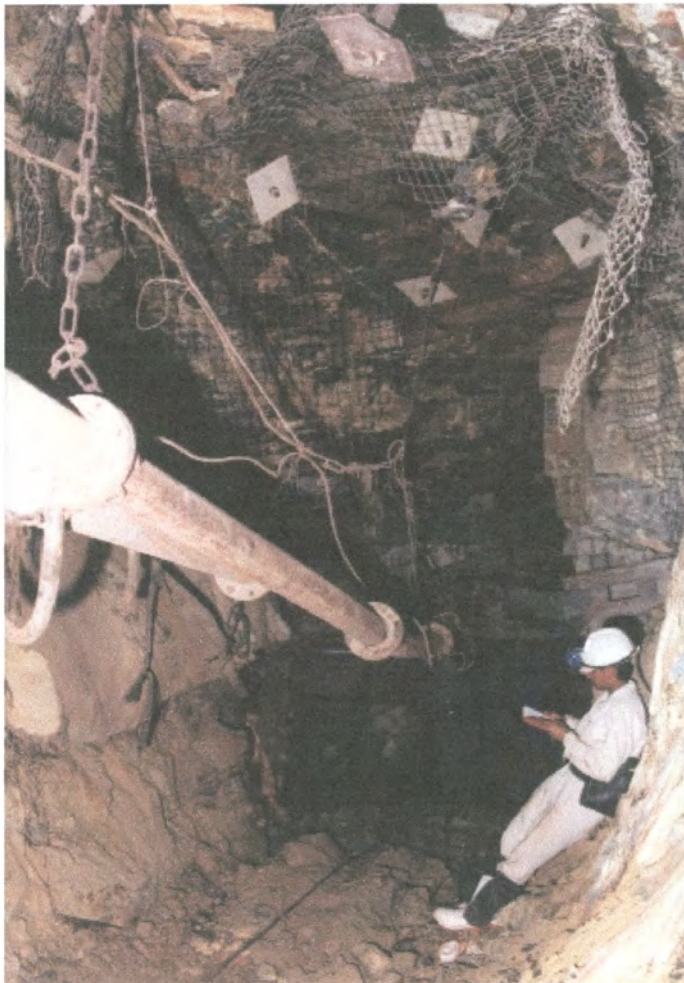

Figure 4.41 - Resin injection used to consolidate a collapsed area over a Carbon Leader dip gully at 3000 m depth



Figure 4.42 – Strike gully on the Carbon Leader reef at 2900 m depth, where a stable long term access has been achieved through using sets and void filling

4.4.3 Effect of reef dip

In most mining areas, reef dip is less than 25 degrees. Areas where reef dip was greater than this were examined, which include the following: -

- The Basal Reef at Bambanani (40 degrees dip, 2500 m depth),
- One of the Kimberley reefs at Durban Deep (80 degrees dip, 900 m depth)
- The VCR where rolls occur at 2500 m to 3000 m depth, locally increasing dip to 70 degrees over short distances.

There was no sound technical evidence that supported industry practice for omission of sidings when reef dip exceeds 30 degrees. However, there are practical limits to mining a siding beneath a gully. Stress fracturing persists at higher dips and, in well bedded strata, stress in the gully hangingwall tends to induce instability along bedding as reef dip increases.

Conditions suggested that as the reef and any hangingwall bedding steepens, the stress in the immediate gully hangingwall increases. Slabs created by bedding tend to buckle more readily, or alternatively stress fractures tend to align parallel to the hangingwall more readily. There appears to be a greater need for some form of siding. The steep dip makes the siding more likely to be cut too flat, breaking into the hangingwall rather than following the reef.

When a weak unit occurs close to the reef hangingwall contact in a steep stope, it tends to lie vertically over the gully presenting a fall of ground hazard. This type of phenomenon was observed on the 10th band of the Kimberley reef at Durban Deep, where a 20 cm weak mudstone overlies the reef and dip is 80 degrees. In addition to changes in hangingwall behaviour, stability in the up dip shoulder of a gully decreases as reef dip steepens.

4.4.4 Contribution of mining practices to gully conditions

Three aspects of mining practice were seen to strongly influence gully conditions: blasting practice, gully direction and support installation. In some situations, poor conditions resulted through bad mining practice and could easily have been avoided if better controls were applied.

4.4.4.1 Blasting practice

While stress fracturing and local geology play a primary role in determining gully stability, poor blasting practice was observed to be a contributing factor in several cases. Certain gullies, in particular at Savuka mine, were examined in detail as the mine had themselves recognised the importance of blasting practice and were changing procedures in an effort to improve conditions.

ASG-type gullies

In an ASG-type gully, a development type blast round is used, with a cut to provide an initial breaking point (Figure 4.38). Relatively dense blast fracturing radiates from the cut position, and may add to the fracturing over the gully position. This is an important contributing factor under moderate to high stress conditions where, lagging sidings give rise to fractures which curve over the gully hangingwall and blast fractures, which combine with stress fractures and bedding to create unstable wedges of ground.

In addition to this, where an ASG-type gully is advanced using a development round, its hangingwall is frequently cut across bedding and is often above the reef hangingwall contact. This gives rise to a brow on the updip side of the gully which can break back into the stope and de-stabilise the stope hangingwall (Figure 4.43).

Wide headings

In wide headings some form of cut is also required to create a breaking point in the face of the heading. The positioning of this cut can strongly influence gully stability. On some mines the cut is positioned directly above the planned gully position. This may lead to blast damage in the immediate gully hangingwall. On other mines the cut is placed in either updip or downdip siding (Figure 4.44), placing any increased damage directly over gully packs. Observations showed no convincing differences between the two layouts.



Figure 4.43 – Development-type round with a burn cut, used to advance an ASG-type gully, here shown in a high stope width area at shallow depth



Figure 4.44 – View into a Carbon Leader wide heading showing the face charged up and ready to blast. The cut is out of sight on the up dip side. Good conditions exist over the gully

Footwall lifted gullies

Various practices exist for ripping gullies in the footwall of stopes and wide headings. Several variations were inspected at Savuka mine on both the Carbon Leader and VCR horizons. At the time of the visits the mine was in the process of improving its gully excavation techniques.

In essence there are two ways of ripping a gully in the footwall of a stope:

1. Holes are drilled downwards from the stope or heading floor into the footwall. These holes are typically in one or two rows, 1 to 2 m apart along strike and most often drilled at an inclination of 45 degrees due to the vertical confines of the stope. This method is generally used where gullies have been allowed to lag some distance behind the heading or panel face and catching up has to be done rapidly. The method rarely achieves a very clean break and the gully floor position is generally very uneven because there is likely to be variation in hole length and angle. Due to this, the spacing between sockets measured in the vamped floor of one gully ranged between 1 m and 3 m apart. Gullies are rarely deep (2.3 m was measured from stope hangingwall to gully footwall in one gully), unless ripped in two passes. This method is generally a quick fix where gullies



Figure 4.46 – Gully ripping blasting practice in a wide heading, which gives rise to conditions shown in Figure 4.45



Figure 4.47 - VCR – good blasting practice - footwall lifted gully advanced incrementally by drilling horizontally in the gully face

4.4.4.2 Siding excavation practices

The accuracy with which sidings are excavated can prove critical to gully stability, particularly when mining in a high stress regime. Sidings should be cut on reef, with parallel footwall and hangingwall surfaces to ensure correct pack construction. They should have sufficient width to have space for a pack plus approximately 1 m behind as a “bump space”, to accommodate fractured ground in the event of seismicity or high stress, without ejecting packs. Drilling to excavate sidings should be done from the siding, in the direction of gully advance, to ensure the siding remains on reef. Various errors were regularly observed during underground inspections:

- Sidings are often cut flat to make cleaning easier. Alternatively the siding floor is flat and the roof follows the dip of the strata. Packs in these are constructed vertically rather than normal to dip and require much blocking on the hangingwall. They are also ineffective. If the siding is entirely cut as a horizontal slot there is a tendency to cut across bedding in the hangingwall, reducing confinement in the hangingwall beam over the gully and encouraging collapse. This practice should be avoided wherever well bedded strata are present. It has been the cause of the loss of many gullies at depth on the Carbon Leader Reef where collapse of the immediate quartzite hangingwall leads to exposure of the weak, laminated Green Bar Shale, which is difficult to control.
- Where gullies with lagging sidings are used, there may be a tendency to allow sidings to lag behind the stope faces (well in excess of standards) then to excavate the siding in one blast. While this may seem an easy option in low to moderate stress conditions the consequences are potentially severe. First, stress fractures develop parallel to the heading sidewall over a long distance prior to siding excavation. These are suddenly exposed over a long length when the siding is finally cut. Second, a long, wide unsupported span is created. Lastly drilling is done downdip from the gully into the reef, and more often than not, this drilling is too flat, resulting in a near horizontal siding.
- Sidings are frequently cut with just sufficient width to install a pack. There is no space behind the pack and as a result where bulking of stress fractured ground occurs, packs end up being ejected into the gully.

4.4.4.3 Gully direction

It was noted in a number of cases that failure to meet gully width standards was the result of minor changes in the direction of strike gullies. If a small change in direction occurs, the gully is no longer straight and the scraper tends to dig into, or climb, the gully wall on the inside of the bend, causing damage to either the gully wall or support or both on that side of the gully. Ultimately the gully edge support will be either undermined, resulting in collapse, or will be pulled out by the scraper. A mild example is shown in Figure 4.48. A larger span results, which, in some conditions may result in falls of hanging. In some cases gullies are required for very long periods of time (in excess of a year), with scraper pulls exceeding 100 m and any curve in the gully undoubtedly causes problems in these cases.

Causes of changes in direction would include:

- Failure to follow gully lines laid out by the survey department.
- Incorrect layout of gully lines.
- A change in gully direction necessitated by encountering a fault or roll.



Figure 4.48 – Scraper erodes up dip sidewall of gully beneath packs

In the latter case, in most examples examined underground the gully was kept straight and merely deepened, however in some cases a small change in direction appeared unavoidable. The kink then occurs at, or close to, the fault intersection, where ground conditions tend to be most unstable (due to fault-bound blocks) and loss of, or damage to, support can be tolerated least. All three cases listed as reasons for changes in gully direction can be avoided with adequate foresight, planning and controls.

4.4.4.4 Influence of support installation

There are two key aspects of basic support installation that influence gully stability: pack construction and rockbolt installation.

Pack construction

Selection of appropriate gully edge support, coupled with correct installation techniques was reviewed during underground inspections.

Adequate installation technique is closely linked to the selection of an appropriate gully geometry that results in gully shoulder stability. Where gully shoulders break back the stope hangingwall and footwall surface, above and below the pack position, as not parallel and the pack will require considerable blocking. The height from hangingwall to footwall is generally greater on the gully side of the pack than on the side into the siding or stope. As closure occurs the pack tends to bulge into the gully, and may be easily pushed out into the gully, ultimately collapsing. This is exacerbated when sidings are cut to inadequate depth and no space is left behind packs for stress-fractured rock to bulk into.

In some mines, when gully sidewalls break back, concrete piers are built to give packs a solid, flat footwall. However this still tends to leave a situation where hangingwall and footwall surfaces are not parallel. Also, building concrete blocks is time consuming and expensive.

Ideally, gully packs should be installed so that they are normal to dip, have a long axis that extends far enough into the siding or stope to extend beyond any gully sidewall instability, and should be placed on a solid foundation, and, if necessary blocked on the hangingwall. Correctly installed packs are shown in Figure 4.49. If prestressing is inadequate packs may become twisted by being snagged by the

scraper. An example of this is shown in Figure 4.50, where ultimately the pack will fall out and have to be replaced.

Concerning selection of pack type, a number of mines were visited where brick composite packs were used along gully edges. In a number of cases, where the gully was advanced as a heading, bricks had been knocked off the pack timbers by blasting, on the side of the pack nearest to the face. This undoubtedly reduces pack integrity and long term survival.

Tendon installation

When a support standard calls for rock bolts, rebars, or other tendons to be installed in the gully it is best to drill tendon holes perpendicular to bedding, or other weak partings. Frequently, the angle of installation is very flat, often less than 45 degrees to the horizontal, with holes directed towards the face. As a result, tendons may be completely ineffective, only bolting the bottom 0.5 metres of hangingwall.

The reasons for incorrect tendon hole drilling include:

- Inadequate height in the gully to drill a vertical hole, using the generally available stope drilling equipment and drill steel. This could either be because the drill steel is too long, or more probably because the gully is either not excavated deep enough or is partly filled with broken rock.
- Poor operator practice or lack of training when using a stope drill machine and air-leg to drill support holes.
- Choice of a rock bolt length that is too long for the standard depth of gully, so that a low-inclination hole has to be drilled to install the support. In effect this amounts to an overall poor design.

Corrective measures are proper controls, good drilling practice, correct equipment (e.g. shorter drill steel to start the hole off, or a drill machine set to only drill vertical holes), and a sound overall design.



Figure 4.49 – Correctly constructed packs, normal to reef, prestressed, with a grout bag



Figure 4.50 – Gully shoulder and hangingwall unevenness results in uneven compression of pack and its eventual disintegration

4.4.5 Gully conditions as a function of depth and geometry

From the underground observations summarised in the previous sections, it is possible to start comparing gully conditions to mining depth.

All the gully sites that were inspected underground were rated in terms of the poor-moderate-good comparative scheme described in section 4.2, and summarised in appendix A.

In general, provided reasonable effort is put into support, conditions can be attributed to local geology and stress, where the stress regime is to a large extent a function of mining depth, locally elevated when mining remnants.

While both depth and stress influence the degree of fracturing that occurs in the high stress concentration areas around excavations, the orientation of fractures, as noted above, is strongly influenced by excavation geometry. Adversely oriented fractures are difficult to support and may lead to hazardous conditions, and potentially poor ratings, in terms of the scheme used.

As a means of evaluating the depth/stress limitations for successful use of the various gully geometries observed, the ratings for each case (in some cases grouped panels) have been plotted against the depth of mining below surface. It was immediately apparent that considerable differences existed between Witwatersrand gold mines and Bushveld platinum mines, hence the data has been split to represent these two regions. It is presented in Figures 4.51 and 4.52. The full range of gully geometries has been broadly grouped into three principal types.

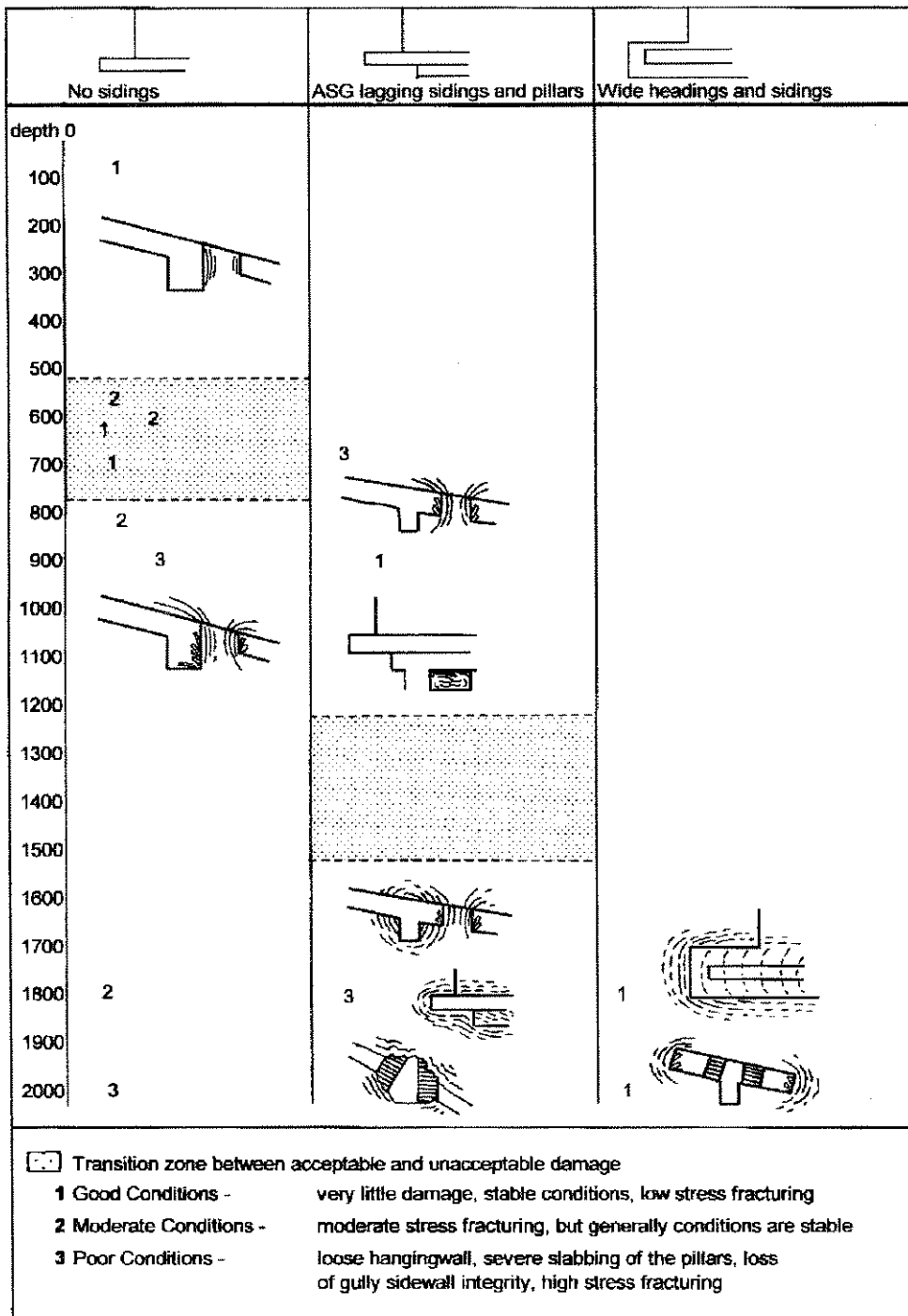

Figure 4.51 - Comparison of gully conditions versus depth in Bushveld platinum mines

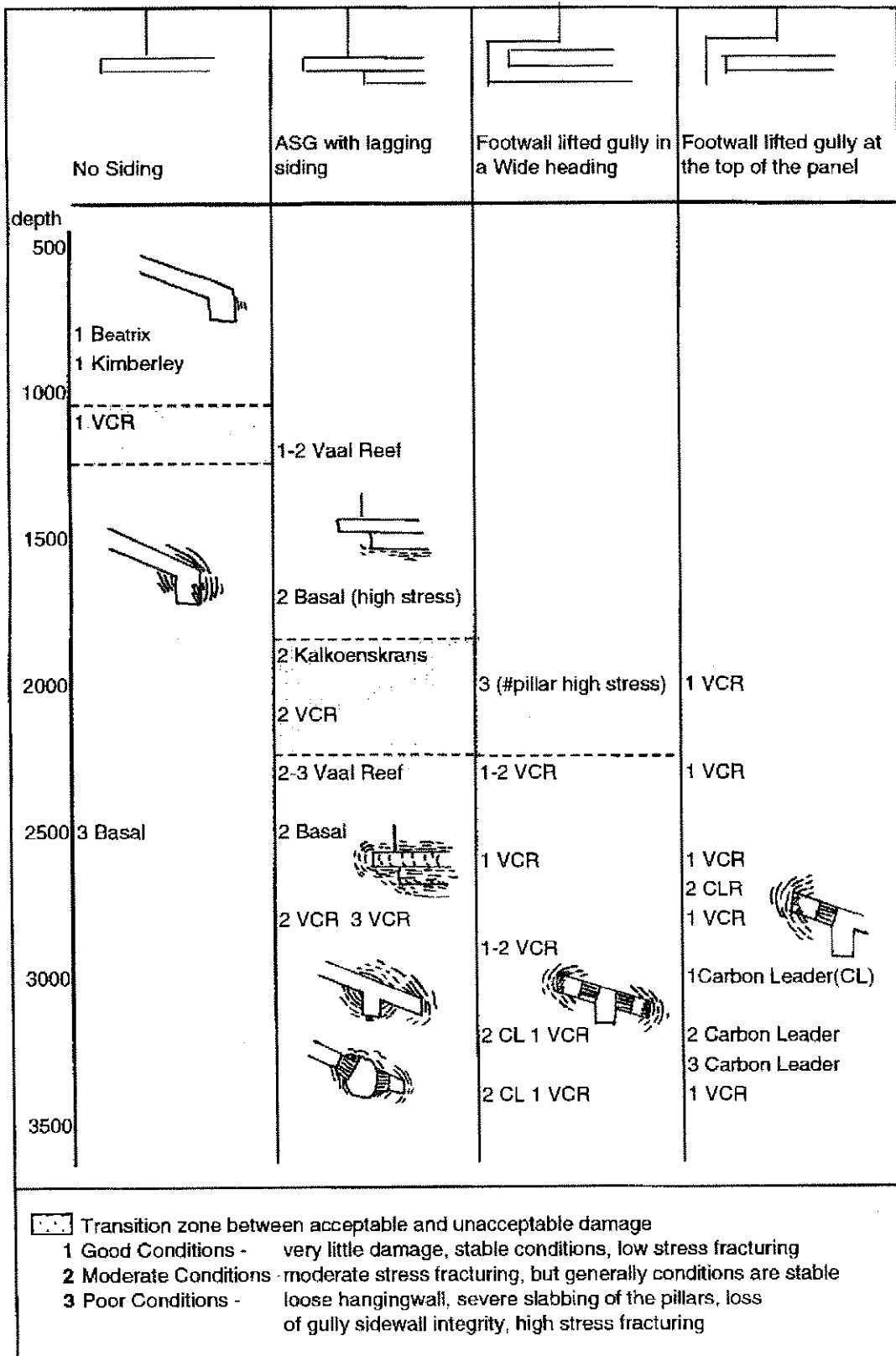

Figure 4.52 - Comparison of gully conditions versus depth in Witwatersrand Gold mines

CHAPTER 5 - NUMERICAL ANALYSIS OF GULLY GEOMETRIES

The previous chapters examined industry-wide thinking and practice with regard to gully layout and design. One of the limitations of observations of different layouts underground is that conclusions can only be qualitative. The geotechnical conditions that exist in areas mined by two different gullies can never be exactly identical and hence an actual quantification of the relative merits of different layouts is difficult. Geotechnical conditions in terms of stress field and rock mass strength can however be made identical in a numerical model, and hence a series of numerical models have been set up to quantify and analyse the merits of different gully layouts.

5.1 Numerical modelling methodology

5.1.1 The modelling process

Numerical models can be used to assist in the decision making process in virtually any field of study, provided the user realises the limitations of the model. The modeller must know what to expect as to the outcome and be able to visualise and anticipate the model solution in broad terms before running the model (Starfield and Cundall, 1988). The primary objective of modelling is to show a correlation between the model and reality, from which certain results can be anticipated or predicted. Models are representations of what could take place in reality, however they are not infallible truths. The thought process involved in setting up, running and analysing models is shown in Figure 5.1. In the context of this project models are used for two purposes:

- To back analyse mechanisms which are observed to lead to gully damage and deterioration.
- To compare the changes in rock mass conditions that are likely to occur when different gully layouts are used, or gully dimensions such as siding width are varied.

For the purpose of this project, both FLAC and FLAC3D (Fast Lagrangian Analysis of Continua), developed by Itasca (2000) were used in the modelling process. FLAC and FLAC3D are finite difference codes for analysis of geomechanical problems

consisting of various analytical stages (as indicated in Figure 5.1). The codes can be used to simulate the behaviour of structures built of soil, rock or other materials, which may undergo inelastic deformation when their yield limit is reached. FLAC3D extends the 2-D analytical capability of FLAC into three dimensions for cases where a 2 D model is inadequate or oversimplified. The rock mass is represented by rectangular and wedge shaped elements within a three dimensional grid, which is adjusted to fit the shape of the object modelled. Each element behaves according to a prescribed linear or non-linear stress/strain law in response to applied forces or boundary constraints (Itasca, 1997).

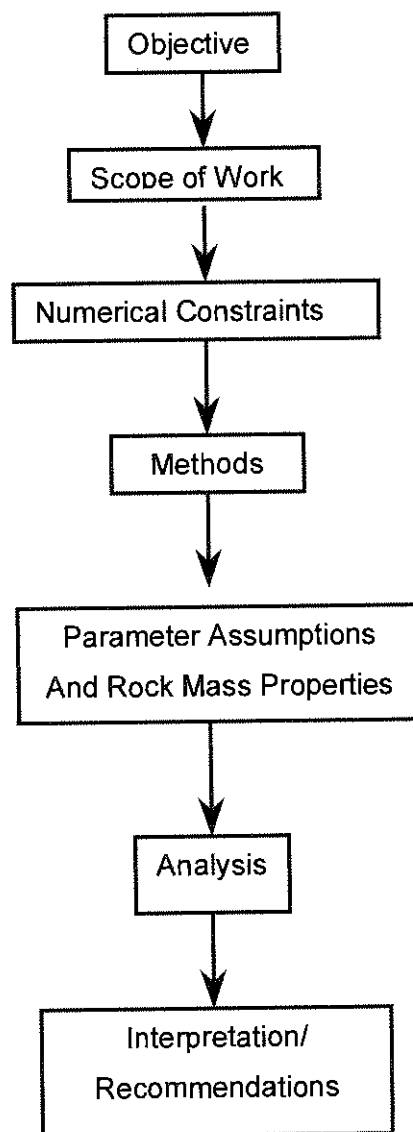

Figure 5.1 Numerical modelling flowchart

5.1.2 Gully model objectives

While a broad guide to best gully practices can be gauged from current mining operations and a review of the literature, there are a number of gaps that are best investigated using numerical models. These areas include:

- A quantification of the relative merits of siding versus non-siding gully geometries under identical geotechnical conditions, where quantification is in terms of rock damage and deformation around the gully position. Cases for shallow mining, where pillars are left adjacent to gullies, and deeper mining operations are considered (two-dimensional modelling).
- The effect of varying rock mass strength and geological stratigraphy on gully behaviour (two-dimensional modelling).
- The effect of increasing dip on damage patterns around gullies (two-dimensional modelling).
- The effect of varying dimensions for heading width and lead, siding width and lag and position of footwall lifting of gullies. Each of these parameters has limiting values if orientation of stress fracturing is to be successfully manipulated to optimise gully stability (two and three-dimensional modelling).

5.1.3 Description of models

5.1.3.1 Geotechnical environments represented

Analyses were first carried out in two dimensions, based on dip sections through stopes, sidings and pillars, then three-dimensional models followed to examine specific gully heading geometries in more detail. Examples of model geometries are shown in Figures 5.2 and 5.3.

Out of convenience, it was decided to base the two-dimensional models around fairly massive rock mass conditions, and eliminate effects due to bedding, jointing or other discontinuities. Underground observations indicated that there are differences in overall rock mass strength between gold and platinum mines that result in the onset of stress fracturing at very different depths. Consequently two groups of two-

dimensional models were set up, broadly representing a typical Merensky Reef rock mass for the platinum models, and a strong VCR rock mass for the gold mines.

Rock mass strength parameters were adjusted to broadly approximate observations of damage at Northam for the platinum cases, and Mponeng and Savuka Mines for the gold cases. The main objective however was to compare the effects of varying geometries, not to establish exactly calibrated back-analyses.

For the three-dimensional models a generalised quartzitic rock mass was assumed, again excluding bedding and jointing. The base criteria for the two and three-dimensional cases are listed in Table 5.1. The assumptions and parameters used to set up the models, followed by a discussion of the results, are presented in the following sections.

Table 5.1 – Basic criteria used in numerical models

	FLAC models (two dimensional)		FLAC3D models
<i>Depth</i>	1800 m	2500 m	2000 m and 3000 m
<i>Rock mass</i>	Pyroxenite	Lava – hangingwall Quartzite – f/wall	Quartzite
<i>Reef dip</i>	20 degrees	20 degrees and 40 degrees	20 degrees
<i>Vertical stress</i>	49 MPa	68 MPa	54 and 81 MPa
<i>k ratio</i>	0.5, 1 and 2	0.5	0.5
<i>Horizontal stress</i>	25 MPa	34 MPa	27 and 40 MPa

Note that there is considerable potential for range in in-situ stress conditions in the Bushveld Complex, with high horizontal stress observed in some areas. While most models, because they were based around observations made at Northam, used a k ratio of 0.5, cases with k ratios of 1 and 2 were also considered as these are possibly more representative of other, shallower, parts of the Bushveld Complex.

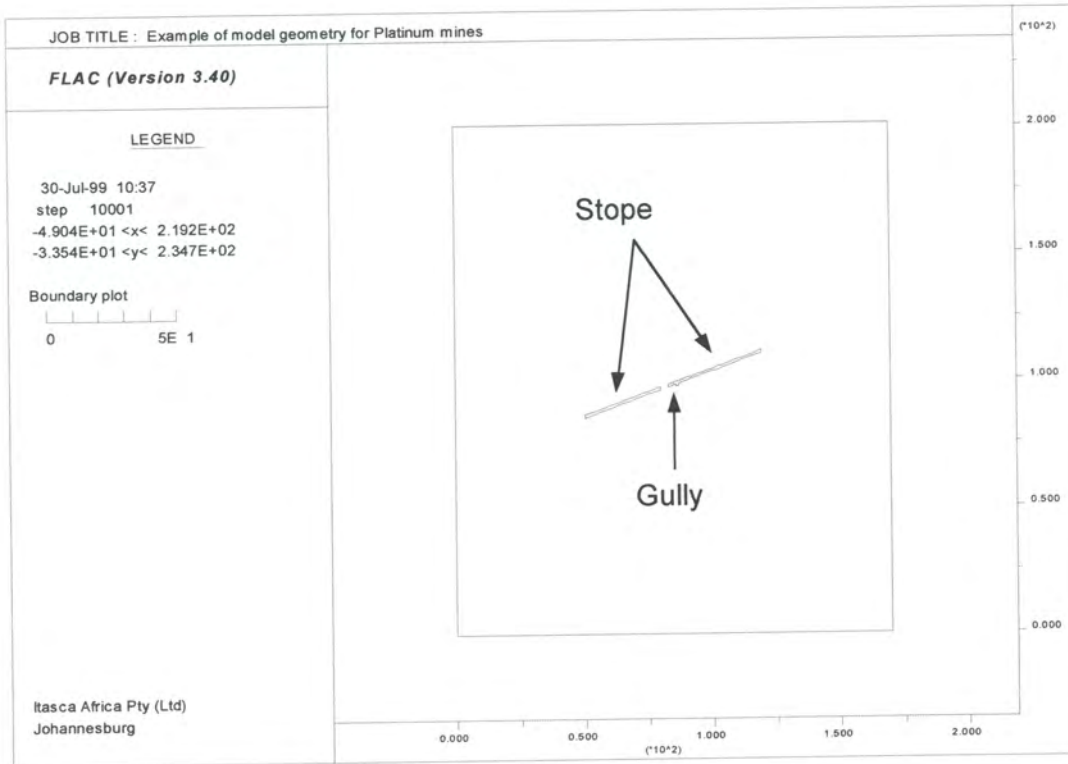

Figure 5.2 – Example of the mining geometry used in two-dimensional FLAC models

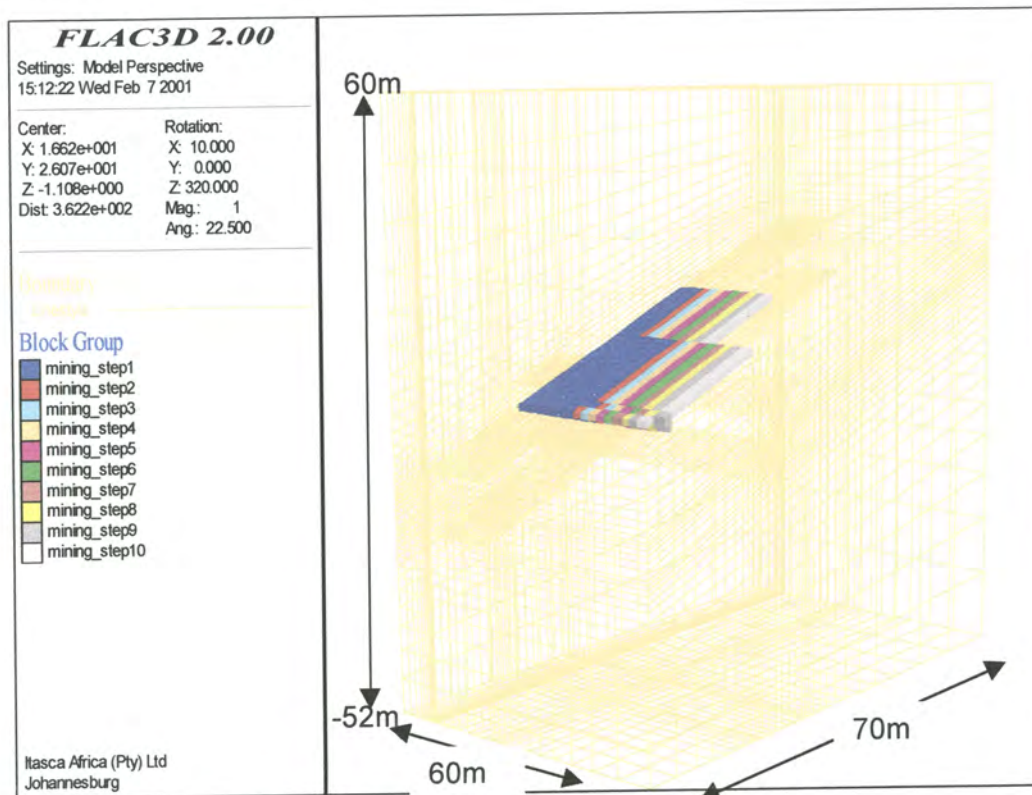

Figure 5.3 – Example of the mining geometry used in three-dimensional FLAC3D models

5.1.3.2 Rock mass properties

Rock mass properties were selected to be broadly representative of either the Merensky Reef conditions or the VCR with a quartzite footwall. A rock mass constitutive model was adopted which permits yield in the material according to a simple Mohr-Coulomb shear failure criterion, with a tensile strength cut off. The shear strength criterion on any selected plane in the material is expressed as

$$\tau = c_o + \sigma_n \tan \phi$$

In this formula, c_o is the rock mass cohesion, σ_n is the normal stress, and ϕ is the friction angle. If it is assumed that strength is the same in all directions in the material, then a generalised relationship with the maximum and minimum principal stresses can be used. This can be generally expressed as:

$$\sigma_1 = k_c \sigma_3 + S_o$$

The Mohr-Coulomb cohesion and friction angle is related to the constants k_c and S_o .

$$\text{Friction angle, } \phi = \arcsin\left(\frac{k_c - 1}{1 + k_c}\right) \quad \text{Cohesion, } c_o = \frac{S_o}{2 \times \sqrt{k_c}}$$

A limitation of the Mohr-Coulomb criterion is that it relates to shear failure only. Rock failure around deep stopes is extensile accompanied by shear failure on discontinuities. There is no adequate constitutive model to represent this type of failure and use of a Mohr-Coulomb material is a best approximation in this case as shearing dominates stress redistribution in solids. FLAC requires values for the Bulk and Shear moduli to determine elastic behaviour prior to failure, plus values for cohesion, friction angle, and tensile strength and dilation angle to define failure stresses. The values used for each material are listed in Table 5.2, derived from generalised property lists reported in Simrac (1999).

Table 5.2 – Rock material properties used in numerical models

	Lava	Quartzite	Mudstone	Pyroxenite
<i>Bulk modulus (GPa)</i>	56	30	46	46
<i>Shear modulus (GPa)</i>	33	23	31	31
<i>Density (kg/m³)</i>	2700	2700	2700	2700
<i>Cohesion (MPa)</i>	22	15	5	9
<i>Friction Angle (Degrees)</i>	47	43	29	36
<i>Tensile Strength (MPa)</i>	3.5	1.5	nil	0.4
<i>Dilation Angle (Degrees)</i>	15	15	10	15
<i>Rock mass property</i>	isotropic	isotropic	isotropic	isotropic

5.2 Shallow platinum cases – sidings and pillars

5.2.1 Geometries examined

Eleven two-dimensional models representing platinum mine gullies with pillars, at a depth of 1800m, were set up using FLAC. The main purpose was to examine the effects that sidings and adjacent pillars have on both the gully and the crush pillar stability. No support was included in the models. The models were intended to be easily compared to the range in conditions observed at around 1800 m depth at Northam platinum mine, although most of the models represent gully geometries observed on other mines in use at shallower mining depths. The typical geometry of the models is shown in Figure 5.2, consisting of a gully placed centrally in the model, a pillar down dip and approximately 30 m of stoping both up and down dip of the gully. The models were divided into four gully categories:

- a) Gullies adjacent to pillars, without sidings
 - 2 m wide pillar, no siding
 - 3 m wide pillar, no siding
 - 4 m wide pillar, no siding
- b) Gullies with angled sidings (inclined down dip sidewall from floor to siding corner)
 - 3 m wide pillar, 1 m wide angled siding
 - 3 m wide pillar, 2 m wide angled siding
- c) Gullies with normal on-reef sidings
 - 3 m wide pillar, 1 m wide siding
 - 3 m wide pillar, 2 m wide siding
 - 3 m wide pillar, 3 m wide siding
- d) ASG pre-developed ahead of panels (multi-step models)
 - 3 m wide pillar, no siding
 - 3 m wide pillar, 1 m wide siding
 - 3 m wide pillar, 2 m wide siding

Models in groups a, b, and c represent the range in possible siding or non-siding cases and were all run as a single mining step with gully, and adjacent stopes up and down dip excavated simultaneously in the model. In some cases this does not adequately represent the real-life rock mass behaviour around the gully, hence the models in group d were run, where the excavations are created sequentially, excavating the gully heading first, then panels up dip and down dip and the siding.

This approximately simulates the effect of carrying the ASG as a heading in front of the advancing stope face. An example of the mining geometry represented in this two-step process is shown in Figure 5.4.

Note that the cases listed in group b represent the situation where, to move the pillar slightly away from the edge of the gully, an additional blast hole is drilled into the hangingwall corner of the face on the down dip side of the gully (as described in section 3). This results in a gully sidewall that angles up from the footwall into this hangingwall corner.

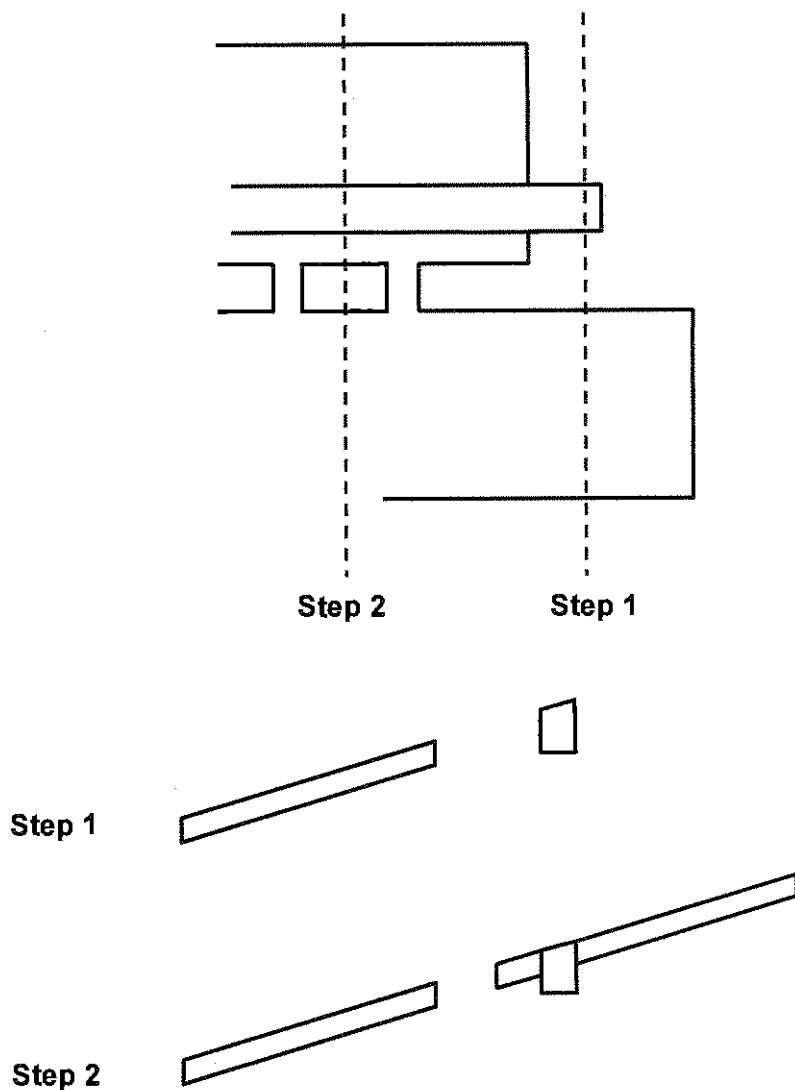

Figure 5.4 – Example of the mining geometry represented in two-mining step FLAC models of platinum mine gullies. Plan (top) shows lines of section represented by mining steps modelled (below)

In all cases the models represented a rock mass with uniform pyroxenite properties. The horizontal and vertical movements (x and y displacements) and shear strain (ssi) at points in the gully hangingwall, footwall and sidewalls were recorded. Average pillar stresses, vertical and horizontal closures of the gully were calculated. Figure 5.5 indicates the monitoring points.

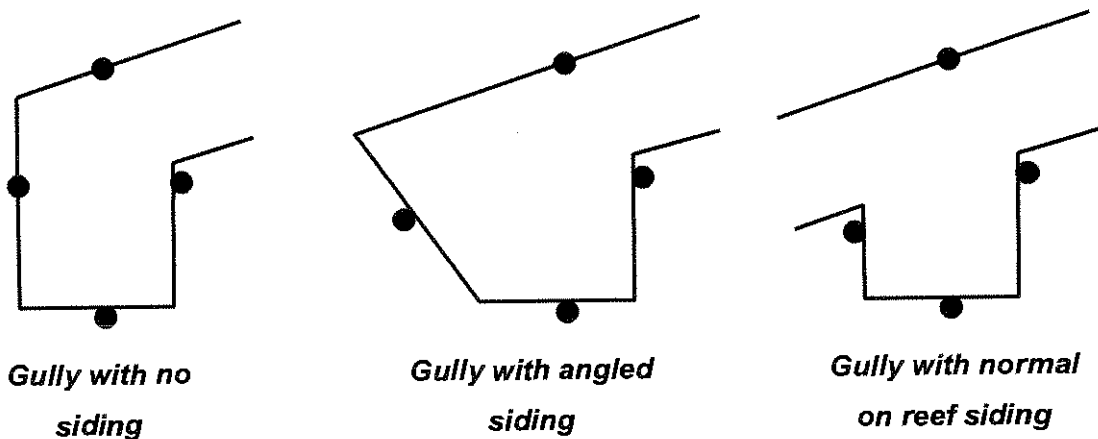

Figure 5.5 – Sketch sections of gully geometries modelled, showing monitoring points used in the analysis

5.2.2 Comparison of modelled platinum gully behaviour

5.2.2.1 General behaviour in the models

Figure 5.6 shows a series of comparative plots from two of the models, which illustrate the general model behaviour. Cases for a 3 m wide pillar are shown, when first, a 2 m wide siding is created between pillar and gully and second, there is no siding and the pillar lies on the gully edge.

The plots from these two models indicate tensile damage over the stope and in the footwall, for a distance of approximately 2 m above and below the stope. Shear failure is indicated in the pillar.

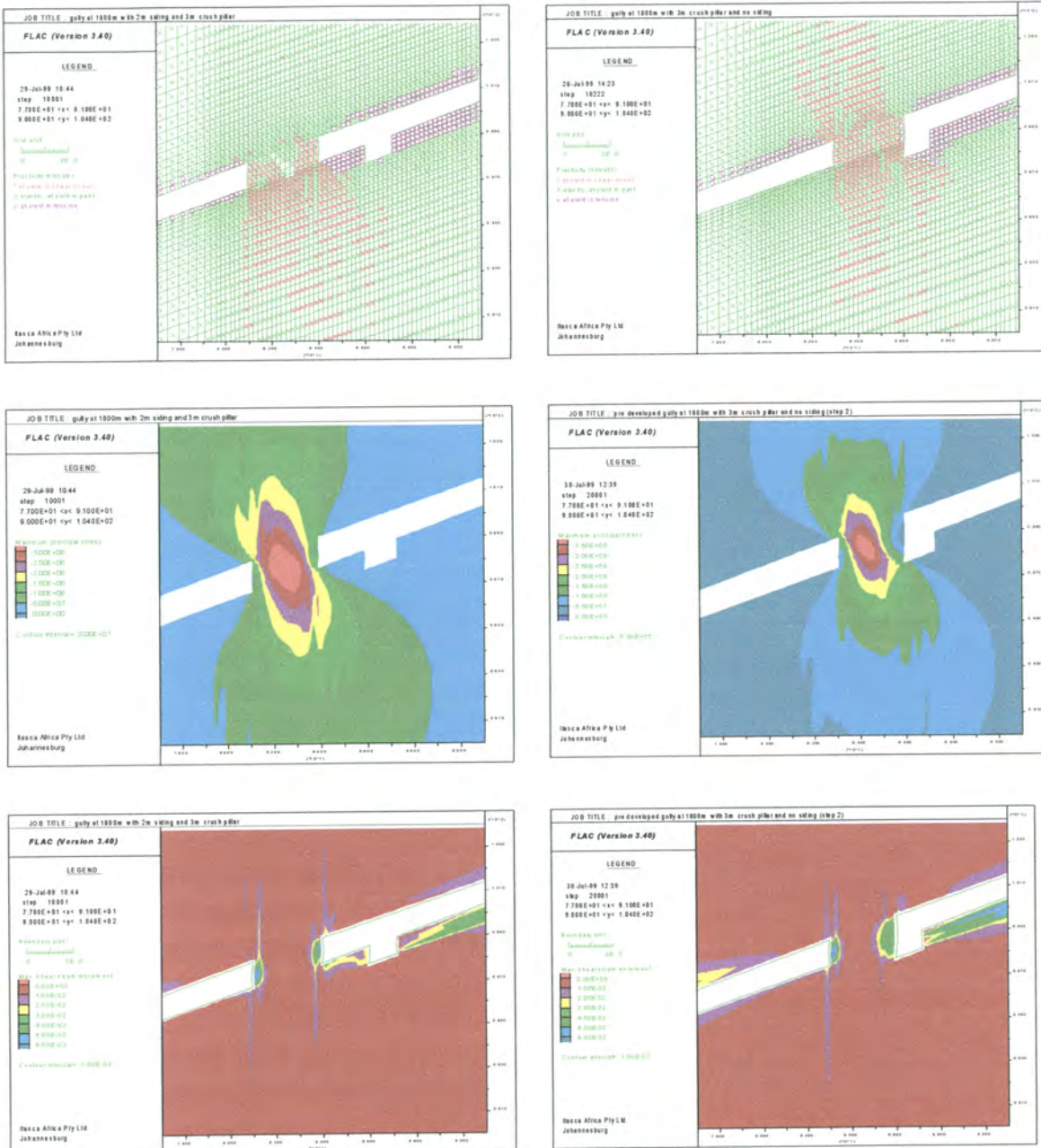

Figure 5.6 – Example of model results showing zone damage (top), stress distribution (centre) and shear strain (below). Models with a 3 m wide pillar, with (left) and without (right) a siding between gully and pillar. Shear strain provides a measure of the severity of damage

In Figure 5.6, high stress levels are transmitted through the pillars and high strains result in the pillar sidewalls. The difference in height of the pillar up dip sidewall (stope height versus gully height) in the two cases does not result in greatly different magnitudes in peak strain, but the volume damaged is increased in the higher sidewall case.

Some high strain areas occur in the hangingwall immediately up dip of the pillars. These are similar to the nature of damage observed underground (see section 4). High strain is also indicated in the footwall of the stope.

Some anomalous narrow high strain bands extend vertically into the hangingwall and footwall, which can be considered to largely be model artefacts and a function of the regular, rectangular grid used. They do not appear to significantly influence model behaviour.

5.2.2.2 Quantification of differences between pillar cases

For all the models, the strain induced in the gully boundaries at the four monitoring points is shown in Figure 5.7. The resulting deformation, in terms of vertical and horizontal closures across the gullies, is compared in Figure 5.8.

From the strains shown in Figure 5.7 it is clear that the greatest amount of rock mass damage is done in the down dip sidewall of the gully. This is expected as this wall is either a highly loaded pillar, or is nearest to the pillar.

Figure 5.7 lists the models in order of greatest strain in the down dip sidewall. The cases without sidings are notably worst, although an angle siding of 1 m depth suffers more damage in its inclined boundary than in the vertical boundary of a 4 m wide pillar. Where sidings are cut on reef there appears to be little difference in the level of strain if the siding is either 2 m or 3 m wide. At a greatly reduced magnitude, footwall strains beneath the gully follow the same pattern as the down dip sidewall. In the right sidewall, strains are greatest when headings are excavated ahead of the stope, and some protection of the right sidewall occurs when no siding is cut on the down dip side and the pillar is large and stable.

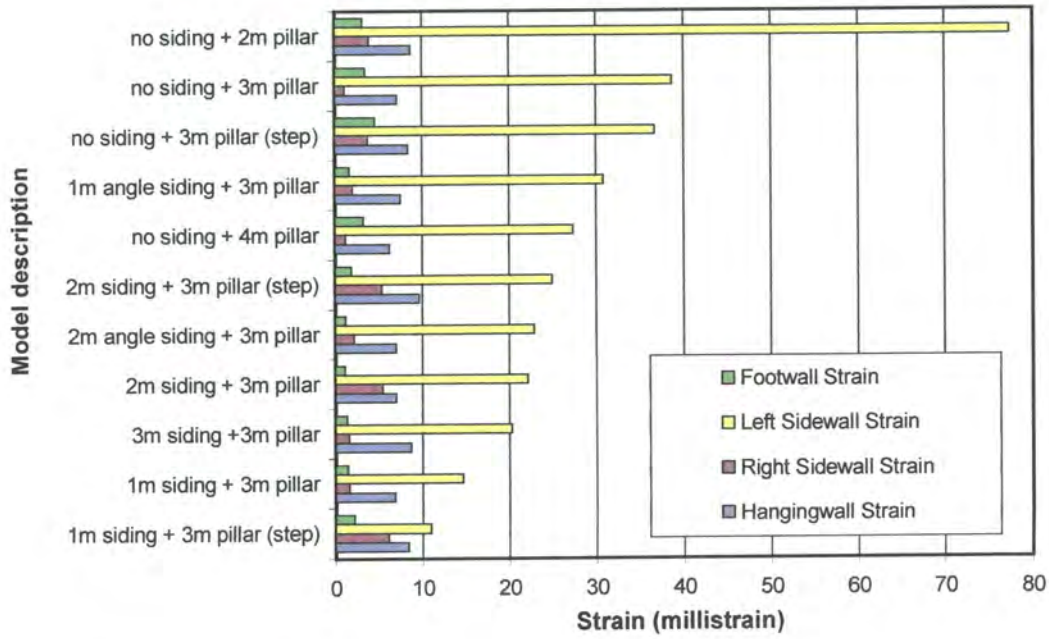

Figure 5.7 – Strains recorded at the four gully-boundary monitoring points in each of the crush pillar models

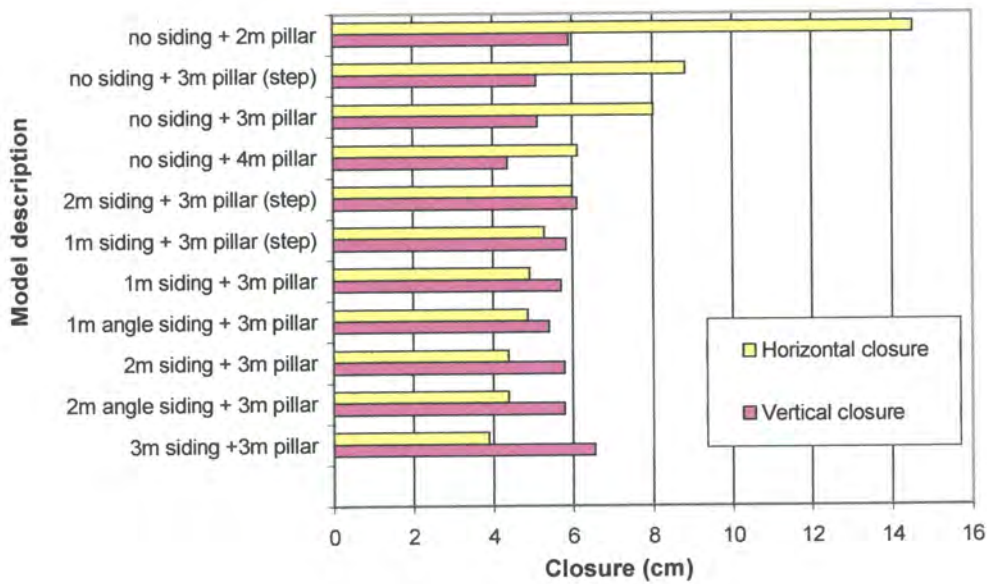

Figure 5.8 – Comparison of modelled horizontal and vertical closures in gullies modelled with adjacent pillars

Following from the high sidewall strains, horizontal closures shown in Figure 5.8 are notably larger than vertical closures and are a function of the level of damage done to the sidewall by high stress levels. The hangingwall does not get damaged by high compressive stress levels and so deforms in tension, as indicated by the magnitude of strain. Figure 5.8 lists the models in order of the worst horizontal closure across the gully. It must be borne in mind that these results are for given stress states, rock properties and depths, as listed in Table 5.2.

Sidewall strain and horizontal closure across the gully in the models is a function of the magnitude of loading applied in the down dip gully sidewall during the model sequence that was run. The greatest loading occurs when there is no siding, and the pillar is at the gully edge. Smaller pillars result in greater strain and horizontal closure than large pillars as they crush and deform more readily. A 2 m pillar shows nearly double the magnitude of strain associated with a 3 m pillar.

The next worst level of horizontal closure occurs where gullies are created as ASG headings, then sidings and stopes are mined. Again, this follows from the level of strain induced in the sidewall prior to cutting the sidings and stope. Vertical closure in Figure 5.8 is a function of distance from the pillar, thus the model with the widest, 3 m, siding shows the greatest vertical closure, followed by the 2 m sidings, etc. The lowest vertical closure occurs when there is no siding and the adjacent pillar is 4 m wide and hence large and stable.

The effect of using a siding to improve pillar stability and possibly permit a reduction in pillar size is more difficult to assess. Figure 5.9 shows the peak strain induced in the up-dip wall of the pillar in each of the models. The highest strains in the pillar walls occur when a 2 m wide pillar is left on the gully edge with no siding. However the lowest peak strain values occur when large pillars are modelled without sidings. Pillars of similar width show higher values of peak strain when moved away from the gully. While this appears counter-intuitive it can be explained. When a siding is introduced, the height of the pillar is less and severe damage occurs over a very limited volume. Without a siding the pillar height on the edge of the gully results in a larger volume over which less severe strains occur, giving rise to greater total strain damage and deformation. In general, based on the observations of gully movements and strains, no improvement in pillar stability is achieved once the pillar is a minimum of 2 m from the gully. Sidings need not be wider than 2m in these conditions. A 1 m siding appears marginally too narrow.

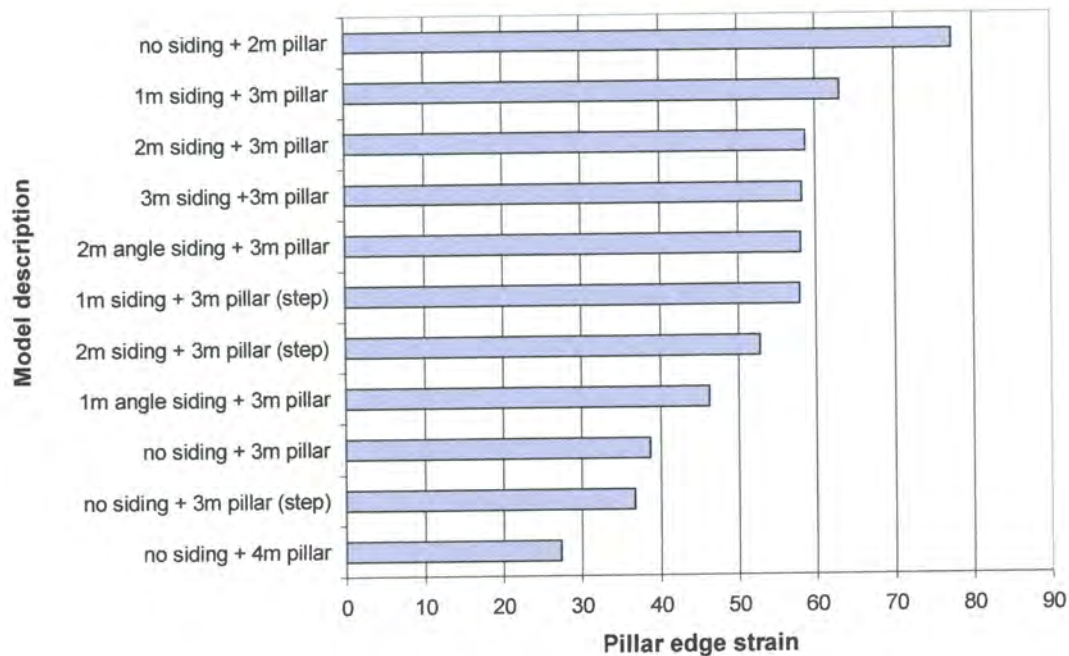

Figure 5.9 – Peak strain values in the edge of the pillar nearest to gully

5.2.2.3 Effect of k ratio on gully stability

A series of models representing a gully with no siding, and a 3 metre wide pillar immediately down dip were run with in situ stress k ratios of 0.5, 1 and 2. The objective was to approximately quantify the influence that variable stress regimes in the Bushveld Complex platinum mines may have on gully stability. In all cases the vertical stress was identical and horizontal stresses differed. Hence the average stress in the rock mass progressively increased with increasing k ratio.

Figure 5.10 shows modelled conditions for the cases where k ratio is 1 and 2. These can be compared to similar plots for the case where k ratio is 0.5, shown in Figure 5.6. In general the three models show similar results. Peak stress in the pillar increases as k ratio is raised and there appears to be an increase in tensile failure over the stope and shear failure over the gully. Peak strains in the gully walls also increase. This is shown graphically for points in the gully hangingwall, sidewalls and footwall in Figure 5.11, with horizontal and vertical closures across the gully shown in Figure 5.12. Hangingwall damage appears little influenced by k ratio, however strain in both sidewalls and the footwall increases significantly when k ratio is increased from 1 to 2. Horizontal closure follows a similar pattern.

k ratio = 1

k ratio = 2

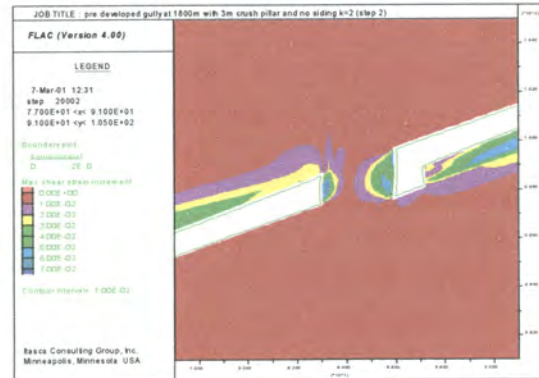
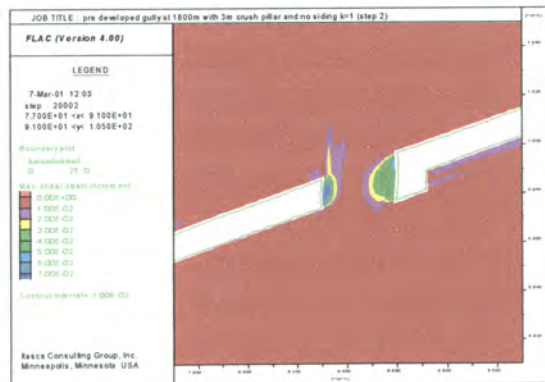
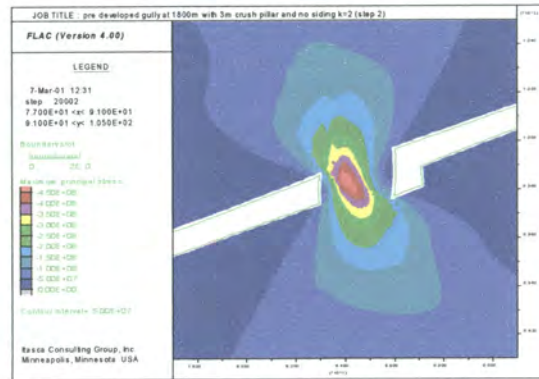
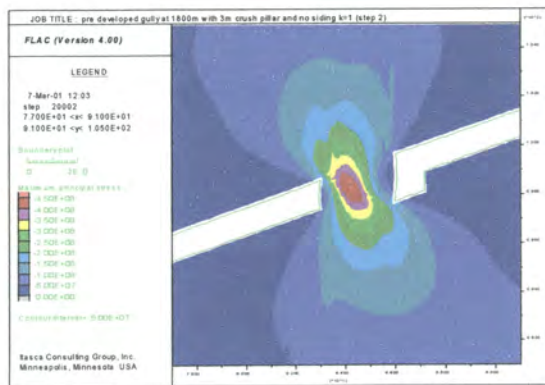
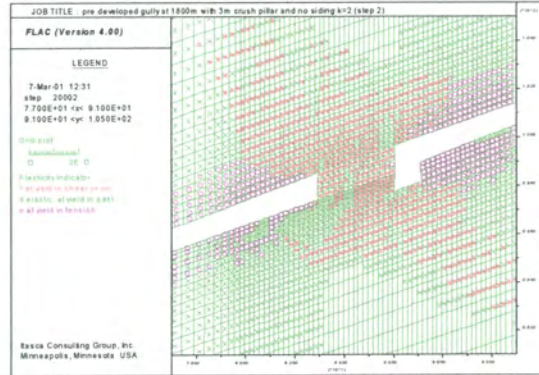
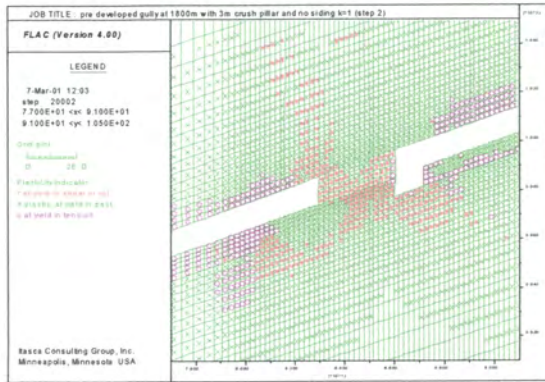

Figure 5.10 – The effect of k ratio on gully stability. Model results show zone damage (top), stress distribution (centre) and shear strain (below). Models represent a 3 m wide pillar without a siding between gully and pillar. Shear strain provides a measure of the severity of damage

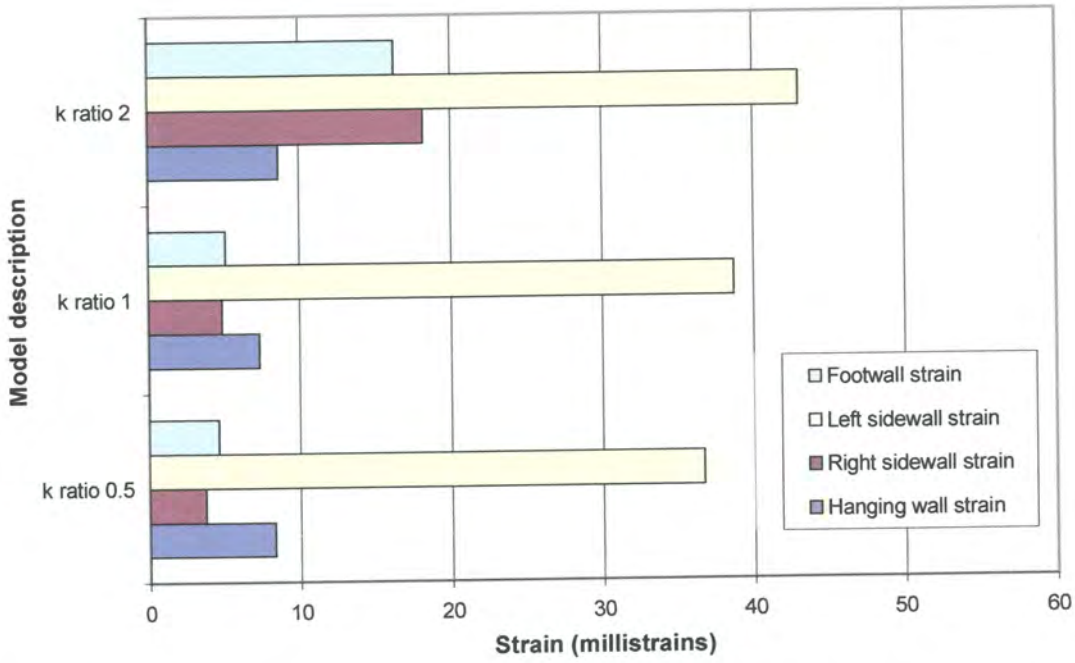

Figure 5.11 – Strains recorded at the four gully-wall monitoring points in models with k ratios of 0.5, 1 and 2

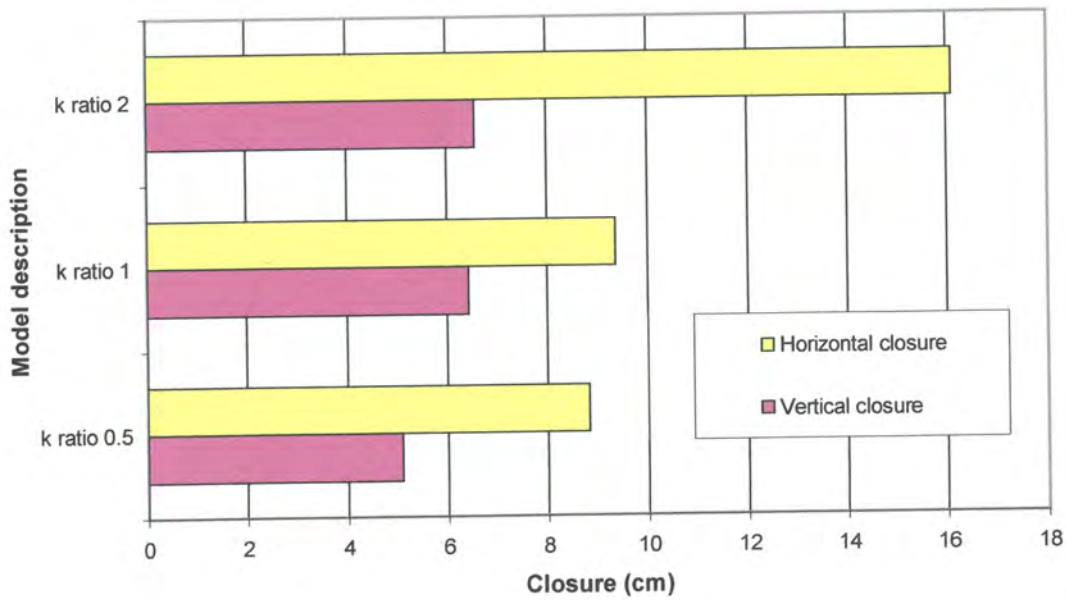

Figure 5.12 – Comparison of modelled horizontal and vertical closures in gullies modelled with k ratios of 0.5, 1 and 2

5.2.2.4 Conclusions derived from shallow models

The following general conclusions can be drawn from these shallower case models where panel support includes a crush pillar:

- Damage to gully walls is minimised if a siding separates the gully and pillars.
- The optimal, or minimum width for a siding is approximately 2 m. 1 m is too narrow. This is both from the viewpoint of minimising gully wall damage and maximising pillar performance.
- 2 m wide pillars are too narrow to be placed along a gully without a siding. 4 m wide pillars are stable, 3 m pillars marginally stable.
- Hangingwall stability is generally good over these shallow case gullies.
- There is a tendency for increased hangingwall and sidewall damage if the gully is cut as a heading in front of the stope panel.
- The main effect of high k ratios which may occur in shallower platinum mines would appear to be to increase horizontal deformation in pillars through an overall increase in average rock mass stress, at similar depth, compared to a lower k ratio. There is some indication of increased damage in gully hangingwall areas.

5.3 Deeper cases – ASG’s and footwall lifting

5.3.1 Geometries examined

For a mining depth of 2500 m five models were run at dips of both 20 and 40 degrees, representing five different gully options used in moderate to deep mining conditions with overhand and underhand mining layouts. All models were run as a series of steps. The mining geometries considered and mining steps modelled are shown in Figure 5.13 and 5.14. The intention was to broadly compare the effects of ASG headings, sidings or no sidings, wide headings and footwall lifting and the effects of reef dip. The five models are:

1. Underhand layout, gully and 2 m siding in line with stope face
2. Underhand layout, ASG gully, with lagging 2 m wide siding
3. Underhand layout ASG gully, without a siding
4. Underhand layout, 6 m wide heading & footwall lifted gully
5. Overhand layout, footwall lifted gully 3 m from top of panel

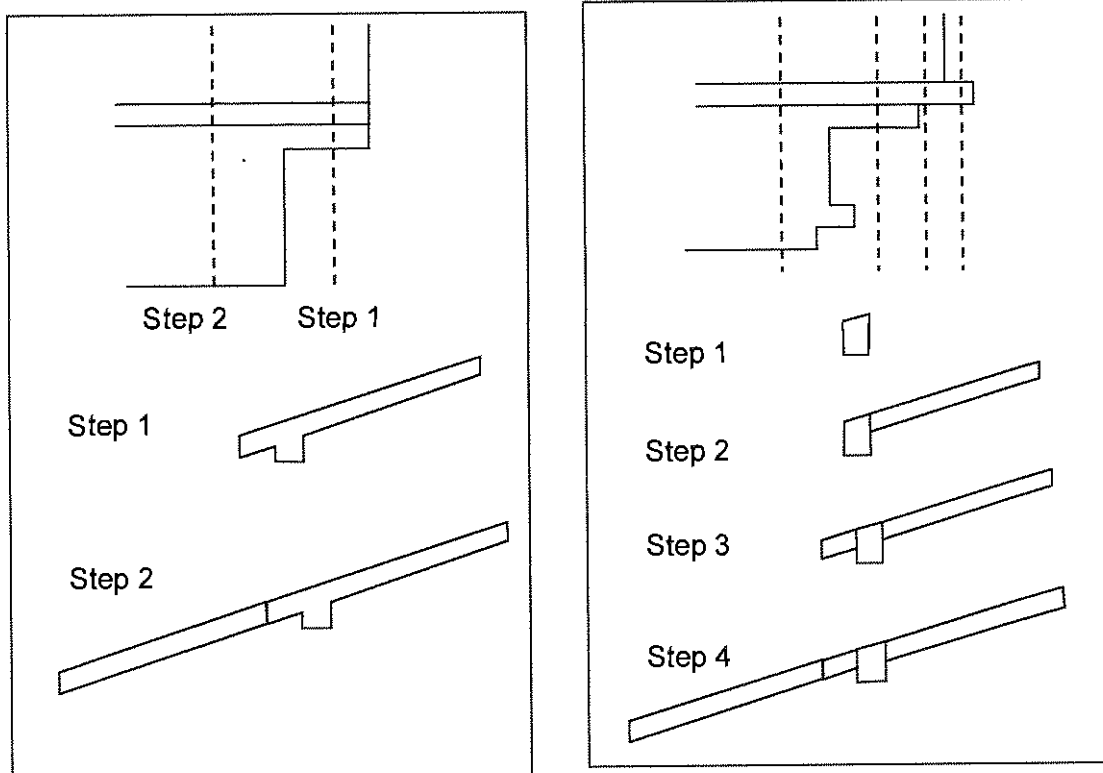

1. Gully & siding in line with face

2. ASG with lagging siding

Figure 5.13 – Deeper mining gully layouts modelled using FLAC

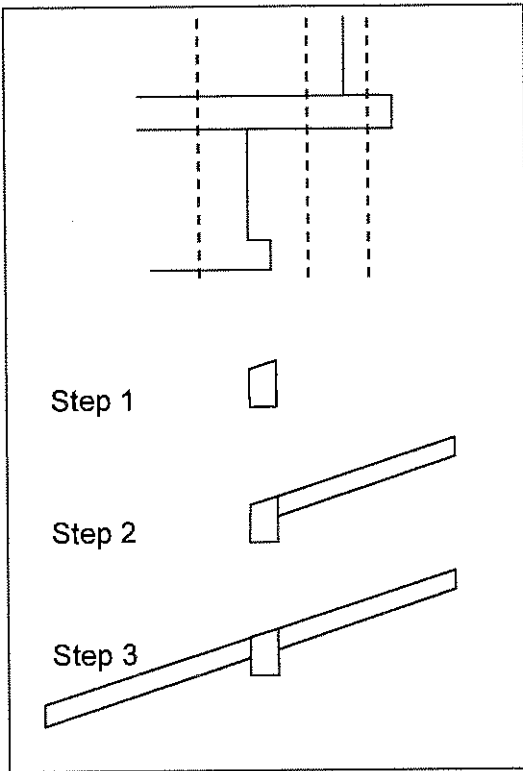

3. ASG Gully with no siding

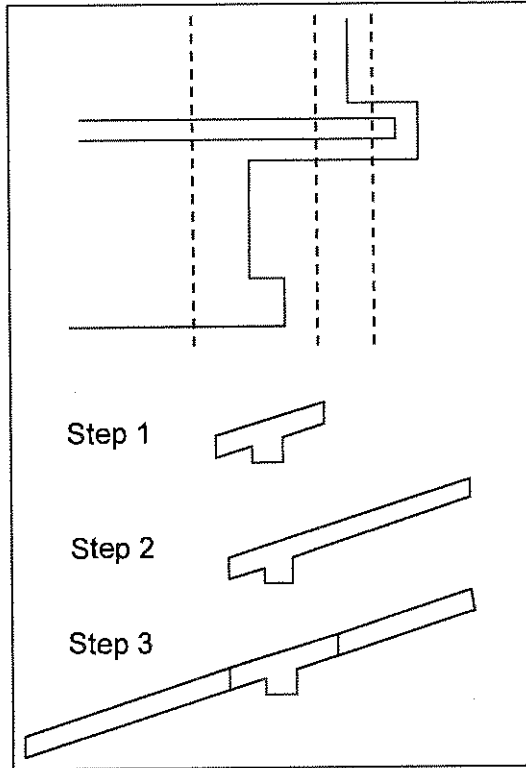

4. Wide heading & f/wall lifted gully

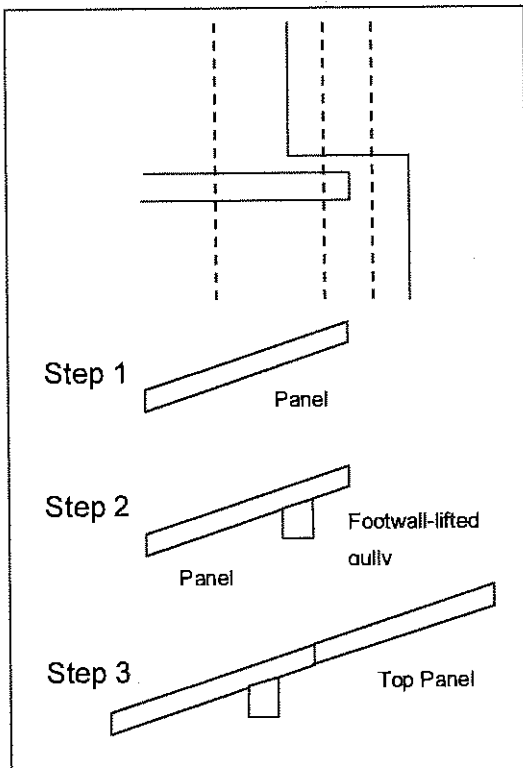

5. Footwall lifted gully near top of panel

Figure 5.14 – Deeper mining gully layouts modelled in two dimensions using FLAC

5.3.2 Comparison of modelled gully behaviour

5.3.2.1 General behaviour in models

As with the shallower case models, these have also been examined in terms of strains in the gully walls and horizontal and vertical closures.

Again, the modelled mining sequence largely determines the level of deformation and rock mass damage that occurs around the gully. The cases which places most stress along the gully edges is where an ASG is developed and the siding excavation lags behind, or no siding is cut. Figure 5.15 shows a series of pictures from the second model, as a means of illustrating the worst-case behaviour, and against which the other sequences can be compared.

Figure 5.15 shows the step by step development of damage around the gully as, first it is a narrow ASG heading, then the stope panel is excavated on the up dip side, and finally a 2 m wide on-reef siding is cut down dip. Stress vectors in these plots show the distribution and orientation of loading around the excavations. These vectors approximately indicate the most probable orientation of induced fractures: near parallel to the maximum principal stress, normal to the minor component.

Damage occurs in the vertical walls (edge of gully, edge of siding) at each step, with an extension of the higher strain envelope into the hangingwall and footwall. This sequence results in clear damage above and below the gully position. Note that footwall damage is greater because of the difference in rock strength.

Figures 5.16 and 5.17 show rock mass behaviour when first, the gully, stope face and siding are cut in line, and second (two plots) when the gully is cut in a wide heading. In both cases the model provides no direct high stress loading at any mining step in the immediate gully sidewall. This results in behaviour in the hangingwall and footwall of the gully where the distribution of strain is more even and lobes of localised increased strain are not observed. The in-line case appears to give the most favourable hangingwall stability results with the band of higher hangingwall strain being considerably narrower than in the wide heading case.

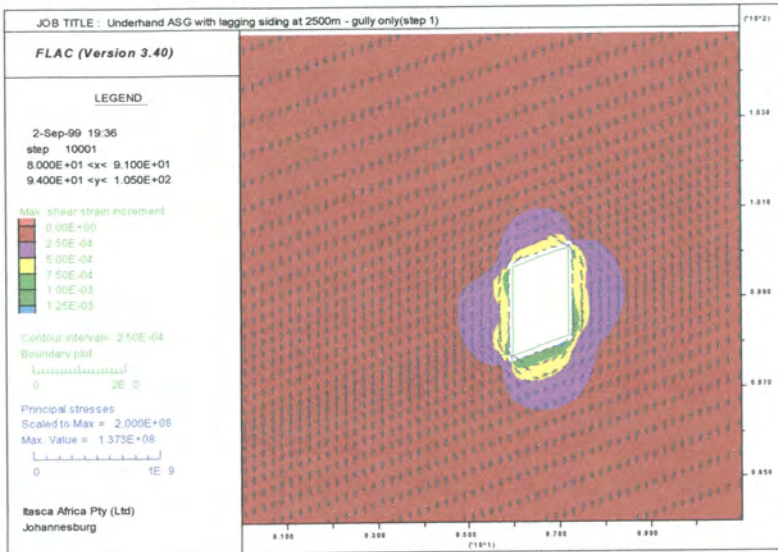
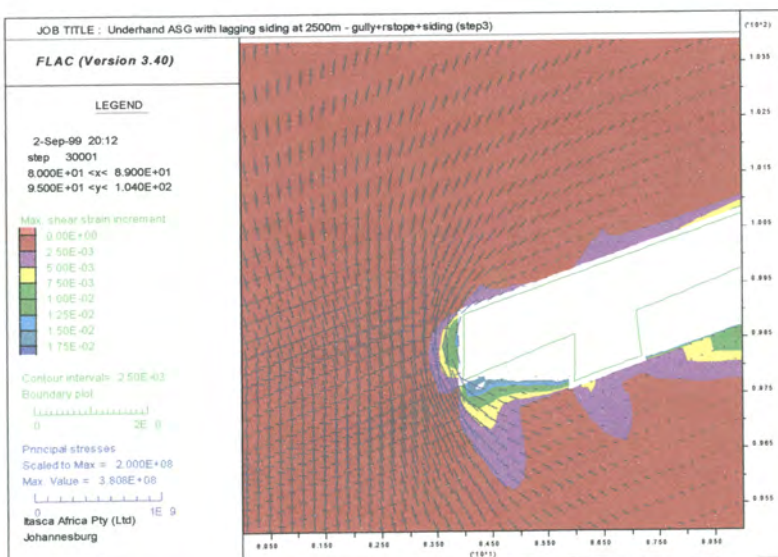
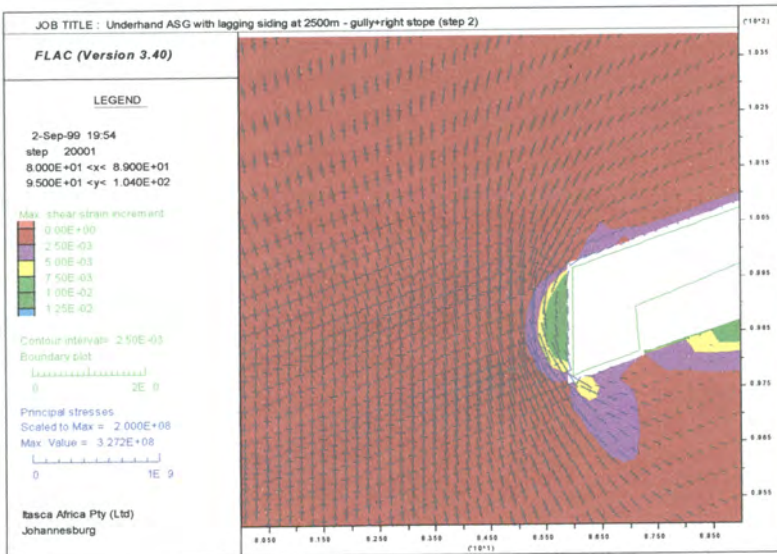

Figure 5.15 – Sequence of plots showing the change in conditions around a gully advanced as an ASG, with stope and siding subsequently excavated around it



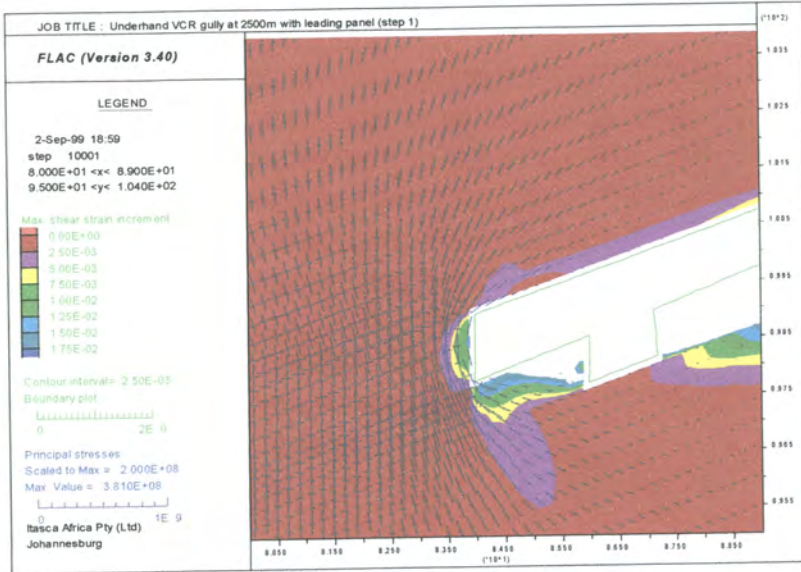

Figure 5.16 – Case of gully, face and siding all advanced in line. Hangingwall and footwall strain is relatively consistent at the gully

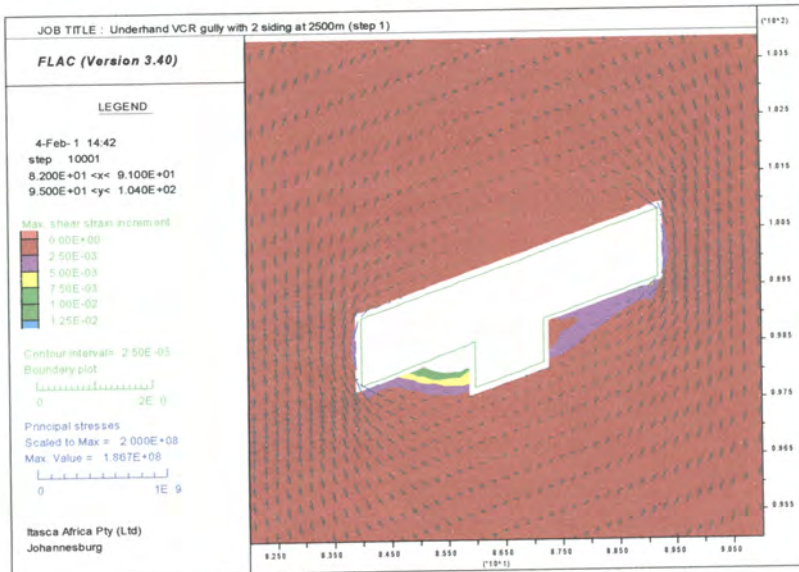
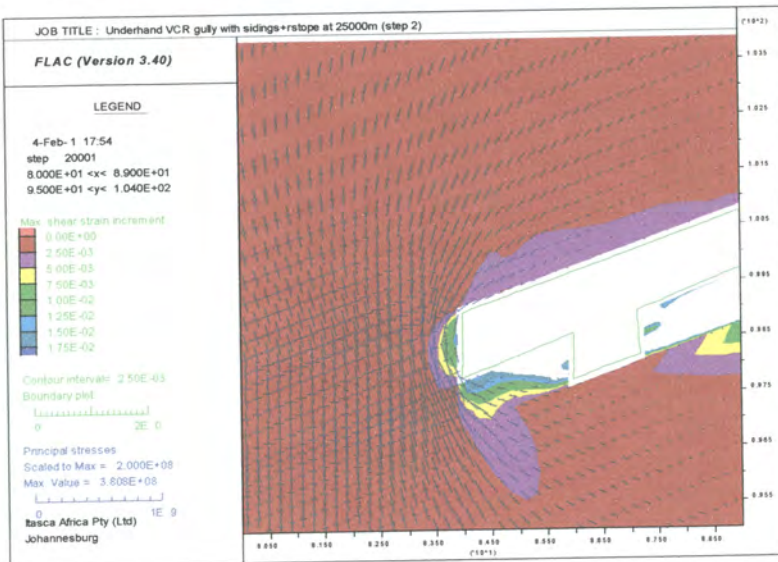

Figure 5.17 – Rock mass behaviour when gully is excavated in a wide heading. In the top view only the heading and gully are excavated, with the up dip slope added in the lower view



5.3.2.2 Comparison of gully types

Gully damage can be directly attributed to the level of stress applied to it during its history. Figure 5.18 shows the peak stress applied to the sidewalls, hangingwall and footwall of each gully in each model. The models are listed in order, with 40 degree dip cases first.

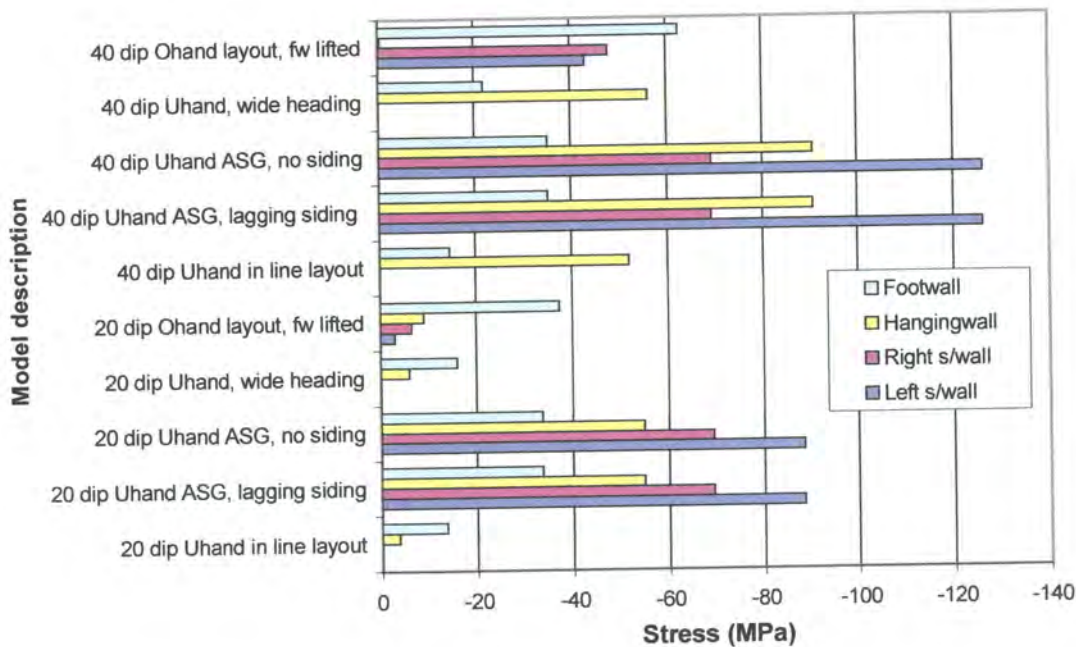

Figure 5.18 – Comparison of the peak level of stress that is applied at any time to gully boundaries throughout each model analysis, for dips of 20 and 40 degrees

Figure 5.18 shows a clear difference in peak stress level applied in the cases where no siding, or a lagging siding is cut and those cases where the siding is cut at the face or the gully is footwall lifted. The wide heading and in-line cases show that almost no stress applied to the gully sidewalls (excluding the stress ahead of the slope face).

As dip is increased from 20 to 40 degrees, there is an increase in approximately 30% in resultant peak stress in most cases. With the overhand layout, (footwall lifted gully case) the peak stresses lie between 40 and 60 MPa when the dip is 40 degrees. While these values are not excessive, the implication is that the gully should be moved further from the abutment at this increased dip.

Following from the level of stress applied to the gully boundaries, a quantitative comparison of each of the models in terms of final state strains and closures around the gullies is made in Figures 5.19 and 5.20.

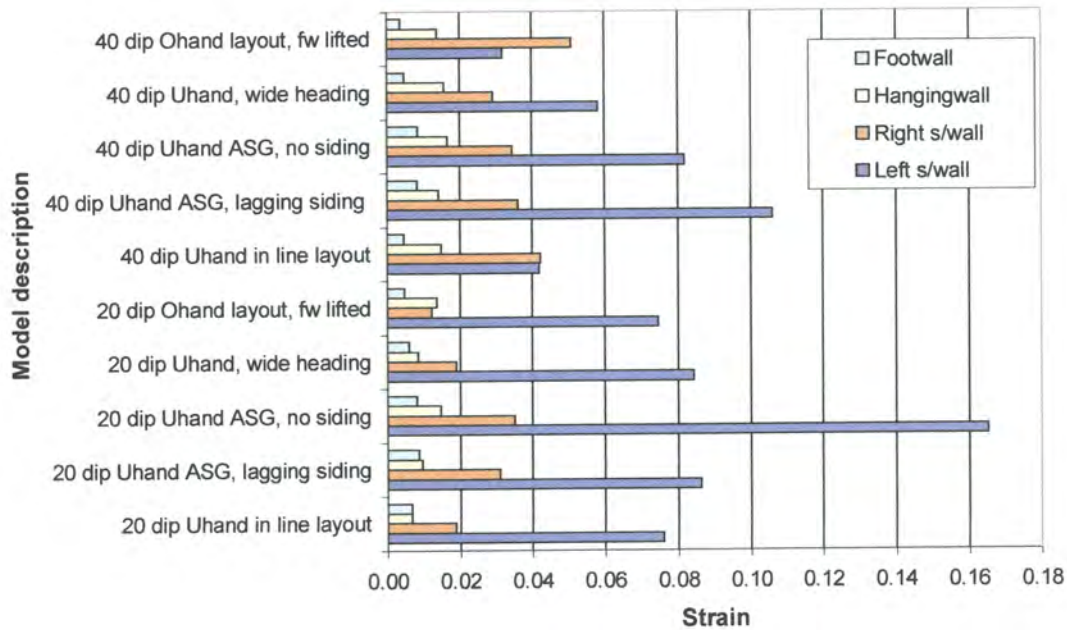

Figure 5.19 – Comparison of final strains induced in gully boundaries throughout each model analysis (20 and 40 degree dip cases, 2500 m)

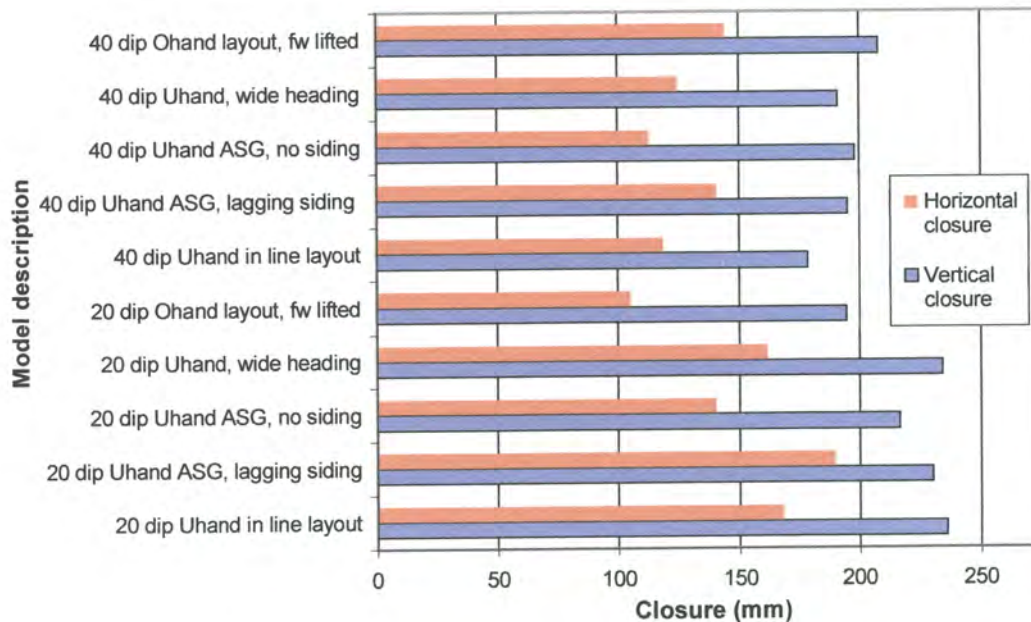

Figure 5.20 – Comparison of vertical and horizontal closures between gully boundaries for each analysis (20 and 40 degree dip, 2500 m)

The strains and closures shown in Figures 5.19 and 5.20 do not entirely follow the same pattern as indicated by the peak stress values in Figure 5.18. The differences between the models are not so well defined.

In general the highest levels of strain occur in the down dip (left) sidewall of each gully, with the exception of the overhand footwall lifted gully, where the nearest abutment to the gully lies updip. The cases where the siding is absent, or lags, again show the highest strains. Wide headings show slightly higher levels of damage than the case where stope face gully and siding are all in line.

The values of closure are inconclusive compared to the shallower mining examples discussed in section 5.2. Vertical closures are higher than horizontal ones. In general, because of the extent of mining, final closure patterns are dominated by the overall closure associated with the mining span, rather than the local effects of gully damage. At 20 degree dip, the highest horizontal closure is associated with cases of lagging sidings, and the footwall lifted overhand case is high at 40 degrees due to proximity to the updip abutment.

On balance it can be concluded that any form of omission of sidings or lagging sidings should be avoided. The preferred layout appears to be to cut the face, gully and siding all in line. The wide heading case appears less effective than this method, however the relationship between heading width, lead and stability requires assessment using three-dimensional models.

5.3.2.3 Effect of dip on gully stability

As noted, there is on average a 30% increase in stress applied to gully boundaries as dip is increased from 20 to 40 degrees. Damage to the updip boundary of the gully tends to increase in all the cases modelled. Conversely, closures are generally marginally higher at the flatter dip.

The models show that, where an overhand layout is employed, footwall lifted gullies should be sited further from the updip abutment than at shallower dip.

In general these models indicate that there is more need for a siding to be cut as dip increases, provided that the insitu virgin stress comprises σ_1 oriented vertically and σ_3 is half of σ_1 (i.e. the k ratio is 0.5).

5.3.2.4 Siting of footwall lifted gullies in an overhand layout

Where an overhand mining sequence is adopted, and gullies are footwall lifted in panels, it was noted that most deep level mines place the gully so that the sidewall is 3 m down from the top of the panel.

In the fifth model considered here (Figure 5.14), the gully was positioned only 2 m down from the top of the panel, but is comparatively shallow, approximately 2.5 m below reef hangingwall. As a result it is positioned in a low stress area, even at steeper dip (Figure 5.21).

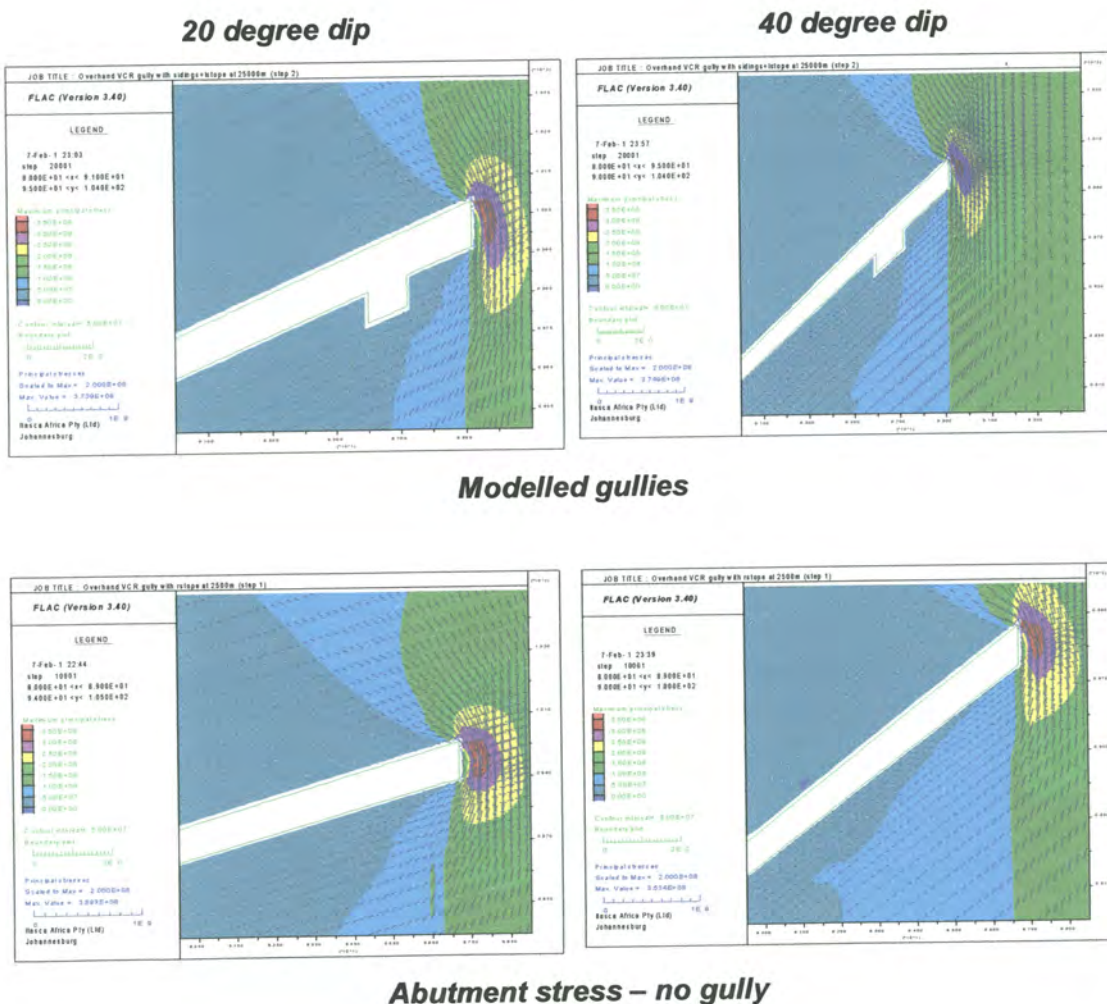
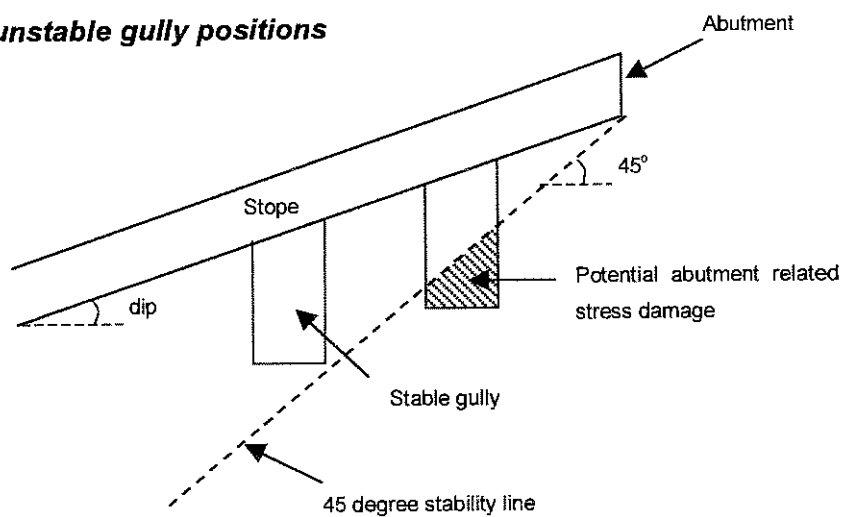

Figure 5.21 – Stress field around modelled gullies in an overhand environment (top), with generalised abutment stress conditions (below)

The stress plots in Figure 5.21 tend to confirm that a 45 degree rule (as used for siting off reef development in a deep mining environment) would also be appropriate for choosing the optimal position for gully excavation, depending on gully depth below reef. Figure 5.22 illustrates this principle. There is a 45 degree envelope angled back below the stope, from the abutment within which no abutment-influenced stress fractures would be anticipated at the gully position. If a gully is deepened below this envelope then flat fractures may be encountered in the base of the gully sidewall, possibly leading to instability problems. A simple geometrical formula relates gully depth and reef dip to the optimal position for gully siting.

Stable versus unstable gully positions



Estimation of stable gully positions

$$\text{Gully position} = \frac{\text{gully depth} \times \sin 45^\circ}{\sin (45^\circ - \text{dip})}$$

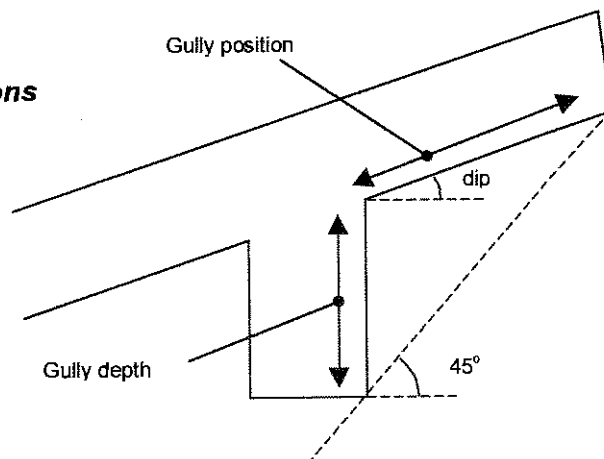

Figure 5.22 – A simple 45 degree rule for siting footwall lifted gullies in an overhand mining configuration

5.4 Three dimensional analyses of gully layouts

5.4.1 Description of three-dimensional model geometries

There are obvious limitations in using two-dimensional models to analyse what is truly a three-dimensional geometry around the heading of a gully and the corner of a panel. A two dimensional model, even when run with a sequence of excavation creation, cannot correctly represent the way in which stresses rotate around the stope face and siding corners, and the damage that results from this.

Consequently, to improve the quantification of the differences between various gully geometries, and to examine the effect that varying certain key dimensions have on gully stability, a series of three dimensional models have been created. These fall into two groups. First a series of single step models of wide headings and ASG's with lagging sidings were examined, where mining is carried out in one excavation increment and stresses and strains around the excavation perimeter are examined. Second, multi-step models of a selection of geometries were run, where a mining sequence is represented and a series of points around the gully position are monitored as mining advances towards and past them. The cases examined included the following:

a) Single mining step models

1. Wide heading, 6 m wide, 10 m lead ahead of panel
2. Wide heading, 8 m wide, 10 m lead ahead of panel
3. Wide heading, 6 m wide, 5 m lead ahead of panel
4. Wide heading, 6 m wide, 3 m lead ahead of panel
5. Wide heading, 5 m wide, 10 m lead ahead of panel
6. ASG, 2 m lead ahead of panel, siding lags ASG face by 2 m
7. ASG, 2 m lead ahead of panel, siding lags ASG face by 4 m
8. ASG, 2 m lead ahead of panel, siding lags ASG face by 6 m
9. ASG, 2 m lead ahead of panel, siding lags ASG face by 10 m
10. Gully, siding and stope face all in line

b) Multi-mining step models (10 steps each)

1. Wide heading, 6m wide, 10 m lead ahead of panel
2. ASG leads panel by 2 m, siding lags 4 m
3. Gully, siding and stope face all in line
4. Wide heading, 7 m wide, 10 m lead ahead of panel

In the ASG models the down-dip siding was 2 m wide in all cases, but was varied in the wide heading cases. The models are all created using FLAC3D and represent a half-symmetrical stope, span is limited due to model size constraints, but permits comparative analyses of gullies under identical conditions. Examples of the model geometry represented are shown in Figure 5.23. In all models the gully under consideration is positioned along the down dip side of two stope panels.

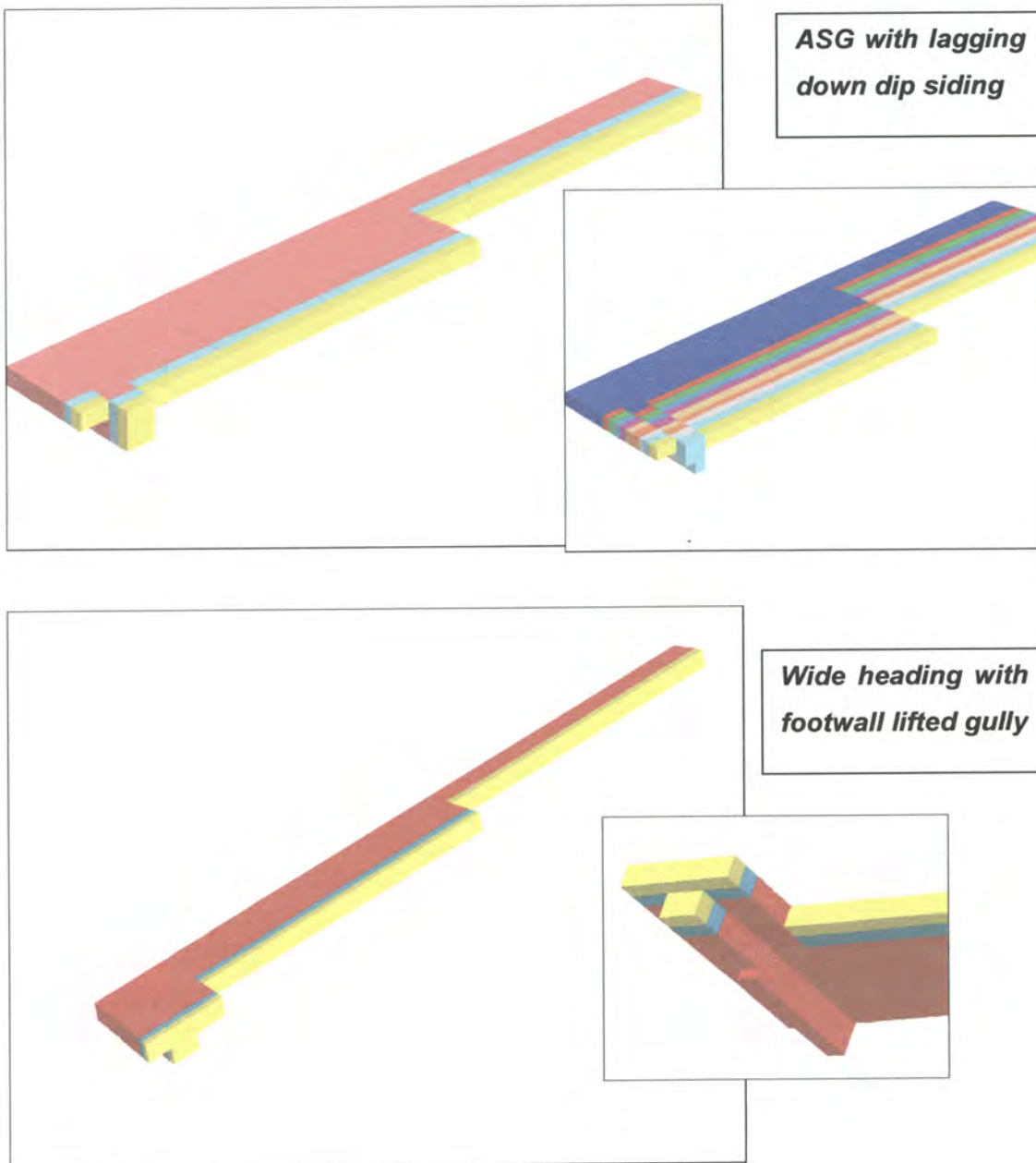

Figure 5.23 – Examples of excavations modelled using FLAC3D. Views show ASG with lagging siding and wide heading cases

In the two dimensional models there was some indication that the differences between gully layouts becomes less distinct as stress and hence depth, increases. Consequently the single step FLAC3D models were run for two mining depths, 2000 m and 3000 m to examine depth effects.

5.4.2 Single step FLAC3D models

5.4.2.1 Analysis method

A limitation of a single step model when represented in a numerical code that permits rock mass failure is that the incremental damage that occurs due to progressive mining is not represented. However single step models are considerably less onerous to run, and can, however, provide a good indication of stress distributions around mining faces, and the magnitudes (possibly exaggerated) of damage that occurs at the highly stressed face positions. An assessment of stress distributions can be used to show what causes damage around an excavation, while strain values is indicative of the magnitude of damage that occurs.

In the single step models stress and strain values were consequently extracted at points around the mining perimeter where it was anticipated that damage would be done that would critically influence long term gully stability. These are the points where stress fractures would form ahead of the gully face, in the gully shoulders and over the gully hangingwall. The points selected are shown in Figure 5.24.

From the Principal Stress orientations at these points an estimate was made of the orientation that stress fractures would develop in, making the assumption that they would lie in the plane of the maximum and intermediate principal stresses, normal to the minor principal stress. Note that although zones may soften in FLAC3D, no actual “fractures” are formed and zones do not become weaker in any in any one direction; the properties, both before and after failure, remain isotropic. This analysis merely examines probable, or anticipated, fracture orientations.

Position of points around ASG with lagging siding

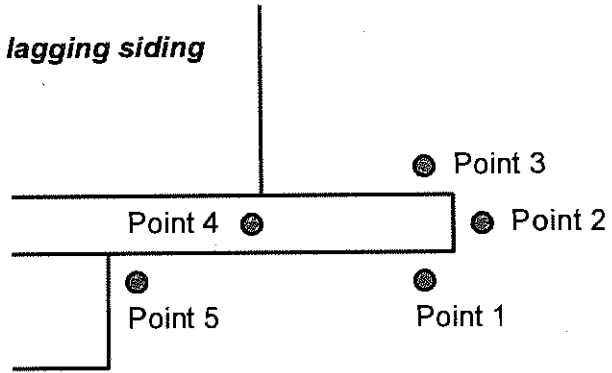

Position of points around wide heading

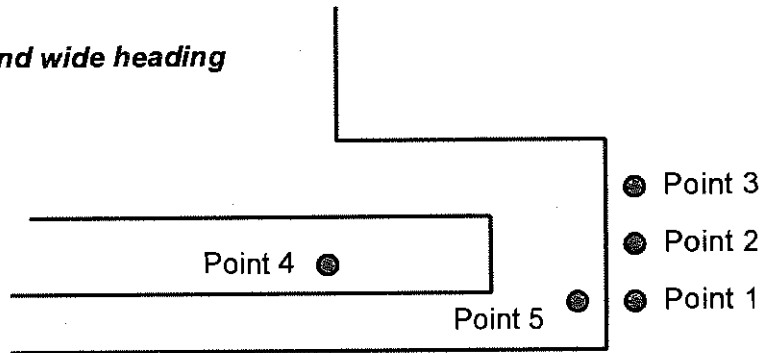

Position of points in section

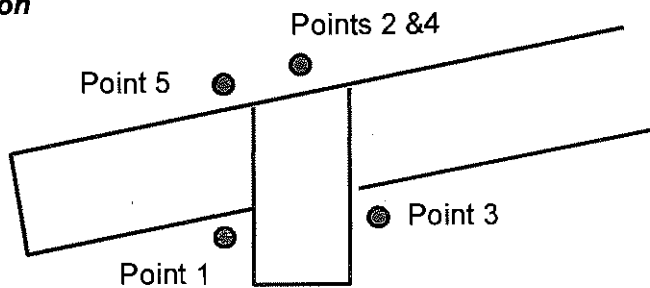

Figure 5.24 - Points where data was extracted from models, corresponding to initiation points for stress fracturing that may influence gully sidewall and hangingwall stability

5.4.2.2 General comparison of ASG versus heading cases

The general result obtained from the models is indicated in Figure 5.25 and 5.26, which illustrate the states of stress and damage in some select examples.

Figure 5.25 shows a reasonable representation of the stress field around an ASG, with high stress ahead of the stope face, penetrated by the ASG, and low stress in the back area footwall. Extent of damage, and typical stress trajectories are indicated in Figure 5.26. These views are typical of model behaviour and are considered a reasonable representation of expected stress distributions and orientations based on underground observations.

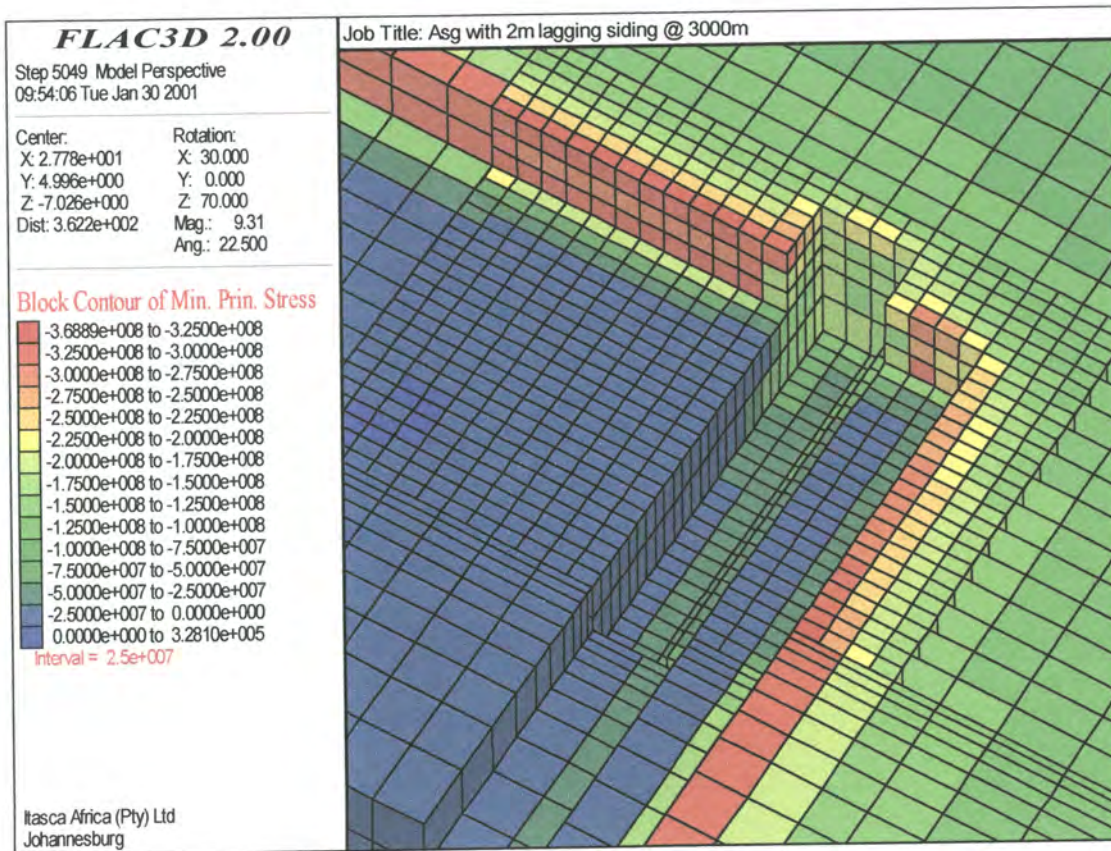

Figure 5.25 – View of an ASG model where the gully leads the stope face and siding by 2 m. The hangingwall is removed to show the model geometry and the rock mass is coloured according to stress level. Note that even a 2 m ASG at 3000 m depth appears to penetrate the high stress zone ahead of the stope face

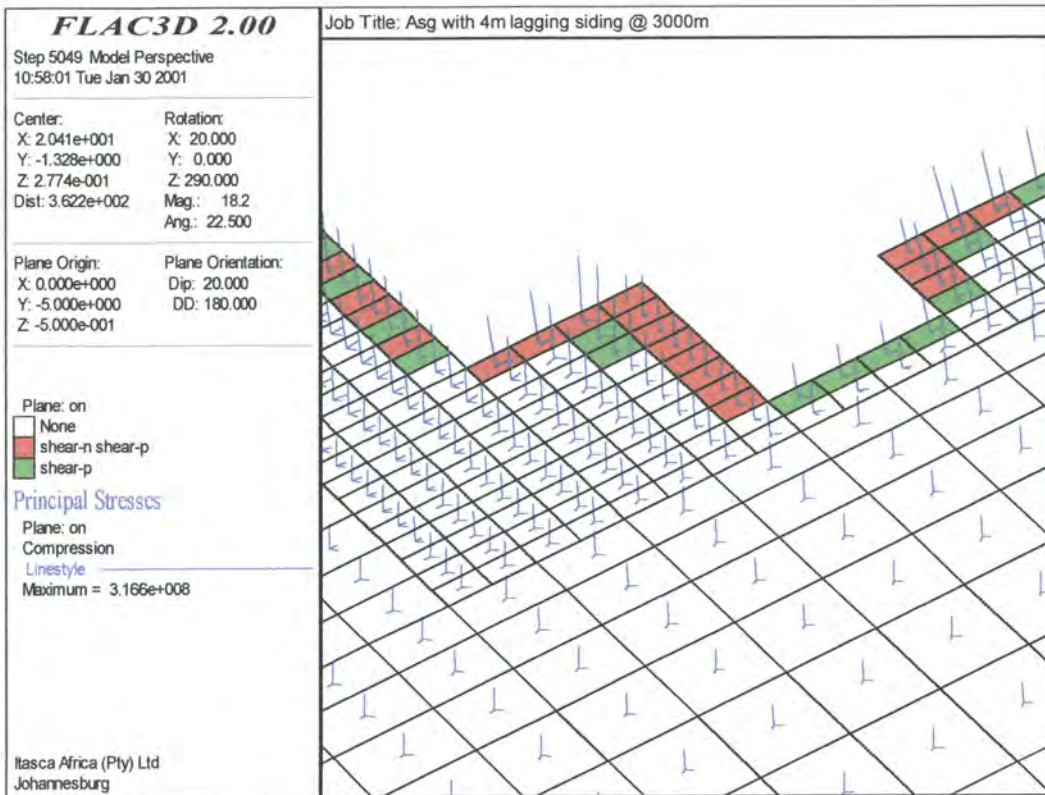

Figure 5.26 – Oblique view of a section parallel to reef at mid-height through an ASG and siding at 3000 m depth, showing the extent of rock mass damage, and principal stress tensor components indicating the stress path curving around and over the ASG heading

As an overall comparison of the ASG and wide heading cases modelled, the stress and strain values extracted at all the monitoring points in all the models are plotted in Figures 5.27 and 5.28. ASG model data is presented on the left side of each graph, heading data on the right. Similar trends are apparent at both mining depths.

The stress levels present around the ASG faces and the wide heading faces are similar in all models. Slightly higher stresses exist ahead of the gully (point 2) in the wide heading case. The main differences are in the stresses at point 4, in the gully hangingwall opposite the stope face, and in the hangingwall over the down dip siding shoulder (point 5). Here the lagging siding causes substantially increased stress levels. These stresses increase in relation to the siding lag.

The strains in Figure 5.28 do not correspond to the stress distributions given in Figure 5.27 because failure has taken place around the excavations. This can be expected. In failure one stress can correspond to an infinite number of strains.

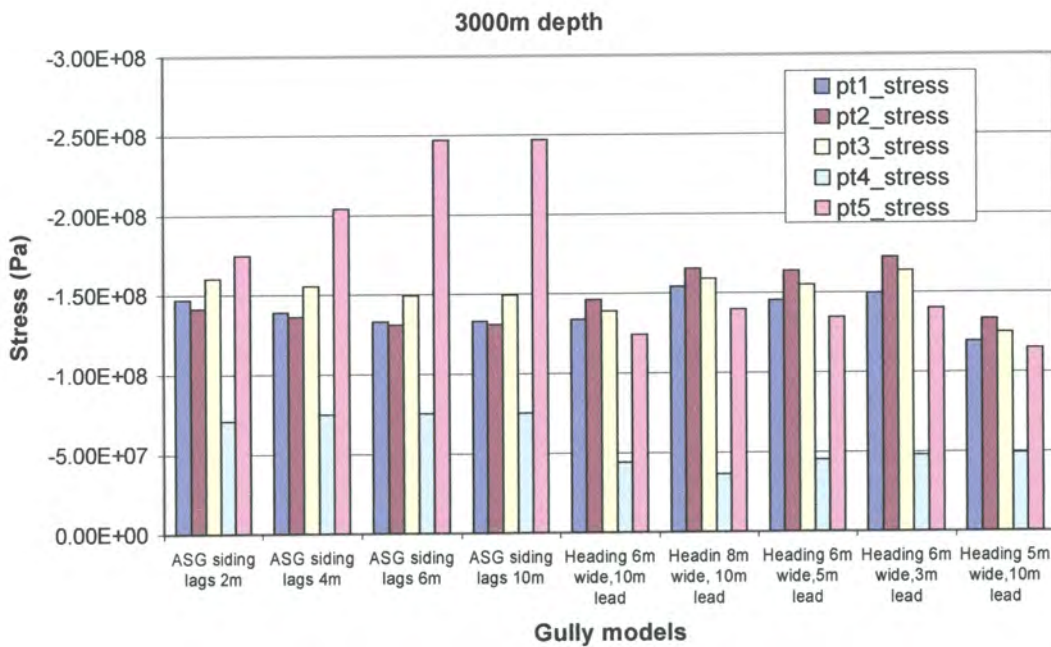
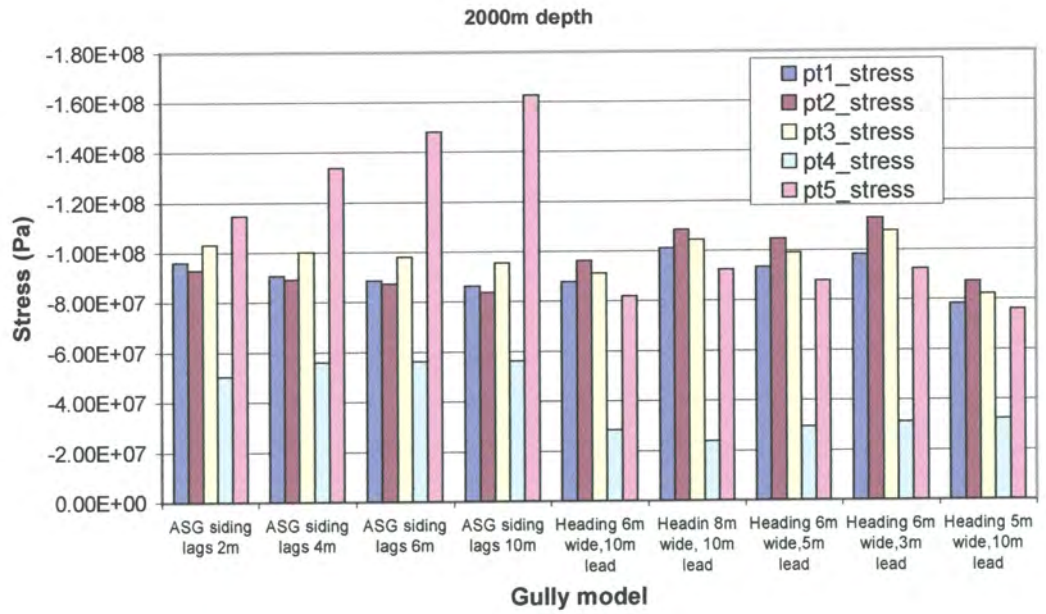

Figure 5.27 – Comparison of stress values recorded at the five monitoring points in the single step FLAC3D models

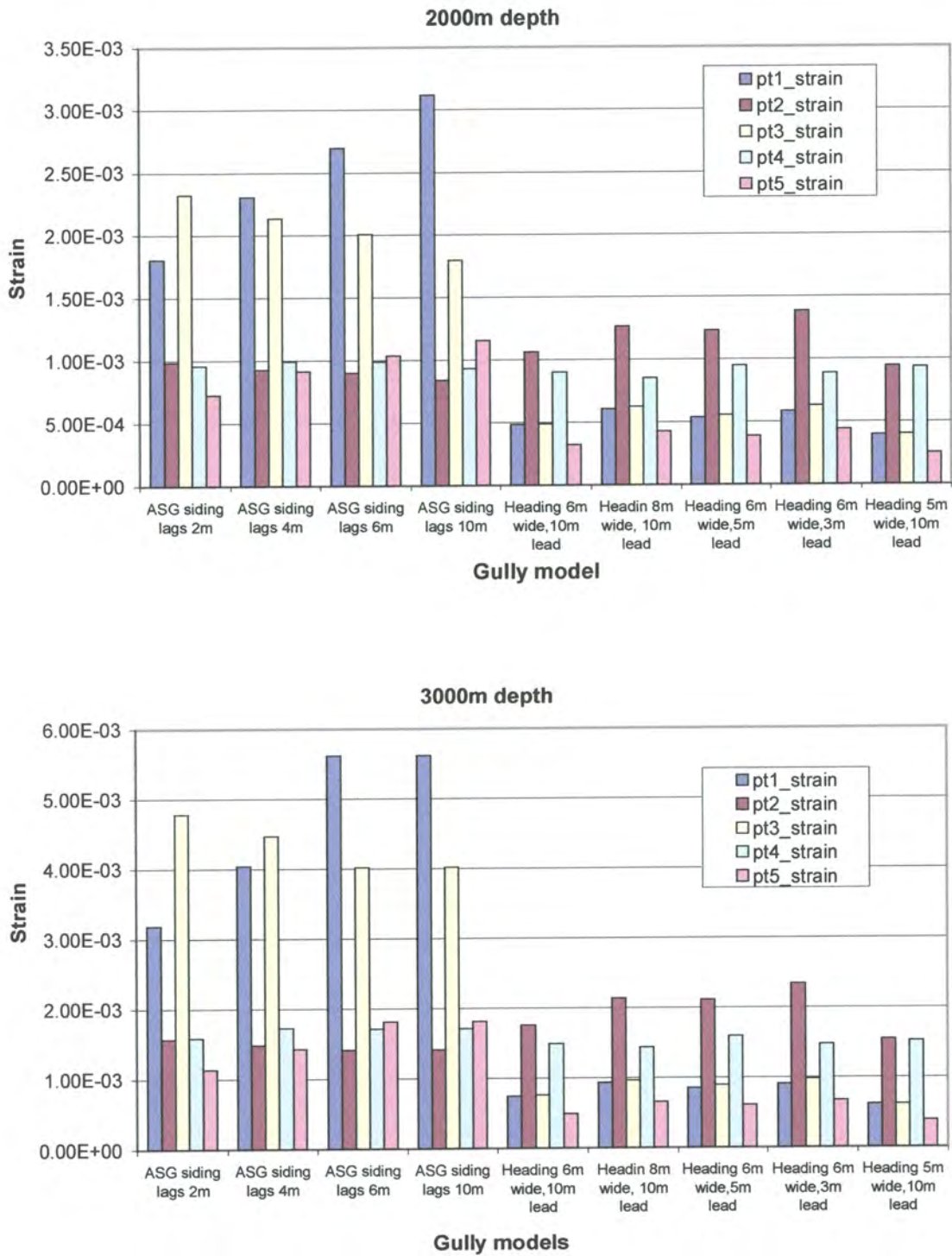

Figure 5.28 – Comparison of shear strain values recorded at the five monitoring points in the single step FLAC3D models

The ASG models show approximately four times higher strains at points 1 and 2, in the rock mass that will form the gully shoulders, and two to three times at point 5, in the rock mass that will form the hangingwall over the down dip side of the gully.

The likely orientations of stress induced fractures that would form at each of the five monitoring points are shown on a Southern Hemisphere stereographic projection in Figure 5.29. These are determined on the basis of being normal to the minor principal stress direction. The poles of the plane were plotted on an equal angle plot with updip being the north position. Similar patterns are seen at 2000 m and 3000 m. Also, independent of local geometry, all ASG with lagging siding cases are broadly similar, as are all wide heading cases.

In the gully shoulders, the data, taken from points 1 and 3, indicates that North-Northwest to South-Southeast fractures would be expected in the wide heading cases. These cross the gully at an angle, rather than being exactly normal to gully direction and dip towards the back area at approximately 60 degrees. In the case of the ASG, the fractures become very steep and trend almost East to West, parallel to the gully direction. Both these fracture orientations are reasonably similar to underground observations. In the case of the wide heading, the trend might give rise to instability in the up dip gully walls, but not as severely as in the ASG case.

In the hangingwall, data from points 2, 4 and 5 are plotted. In the wide heading case the points group to give a single general orientation with a North to South trend, dipping towards the face at 60 degrees. In the ASG case two groups are seen, a steep dipping group, trending Northwest to Southeast, diagonally across the gully, with a second, flat (30 degree) set dipping down dip. Again these would reasonably represent underground observations. Again, also, the wide heading case gives rise to orientations that are most easily supported, while those created in the ASG case are at more difficult orientations.

Figure 5.30 shows the probable fracture orientation, with distance off the gully centre line, for a selection of the models. All wide heading cases are 6 m wide, and are compared to one of the ASG models, plus the case where stope face, gully and siding are in line. Solid and dashed lines indicate the gully centreline and approximate sidewall positions, respectively. The graphs are based on stress orientations ahead of gullies in the 3000 m depth models.

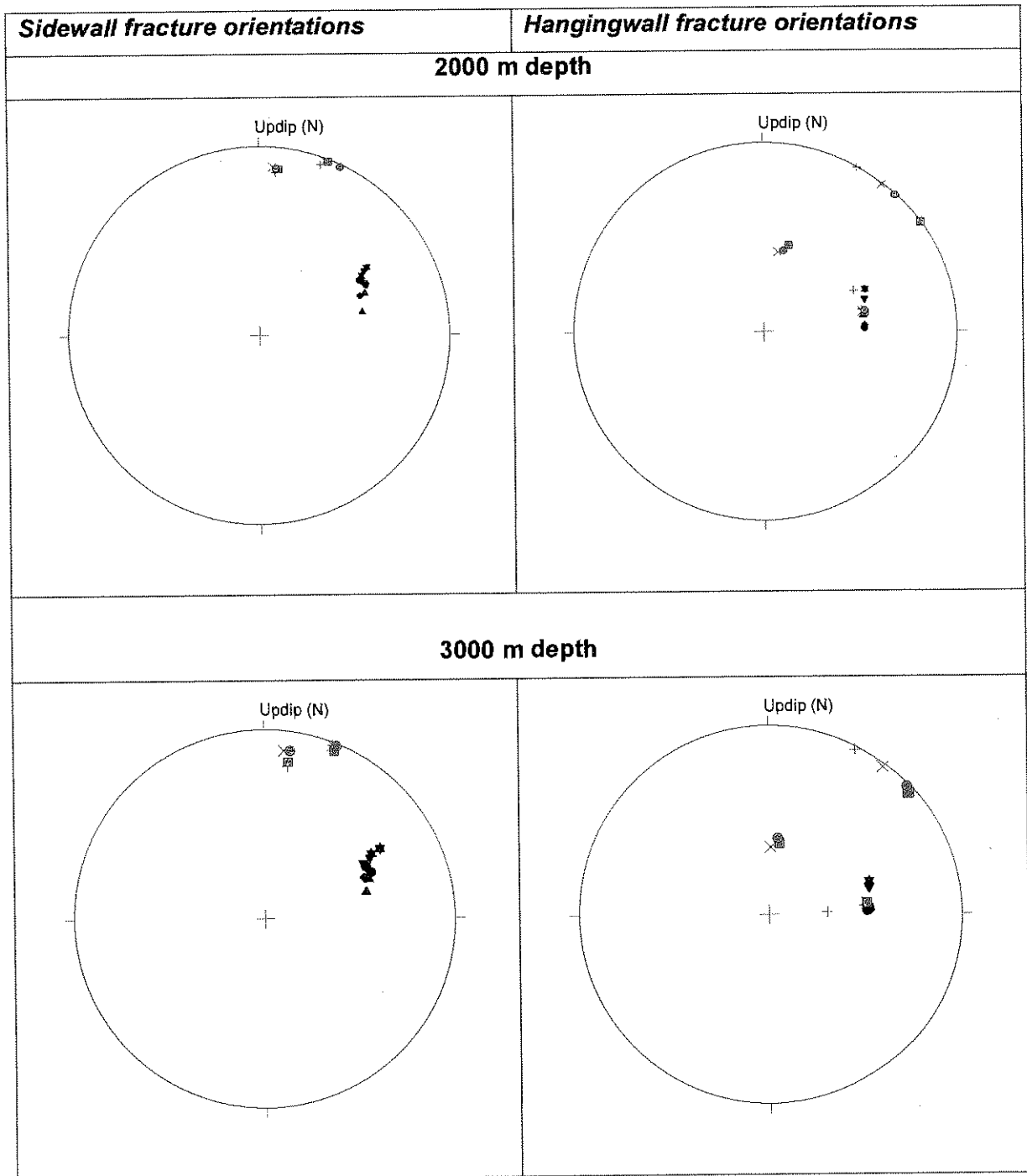

Figure 5.29 – Southern hemisphere stereographic plots showing poles to planes of anticipated stress induced fractures in the gully shoulders and hangingwall in ASG (red symbols) and wide heading (black symbols) cases

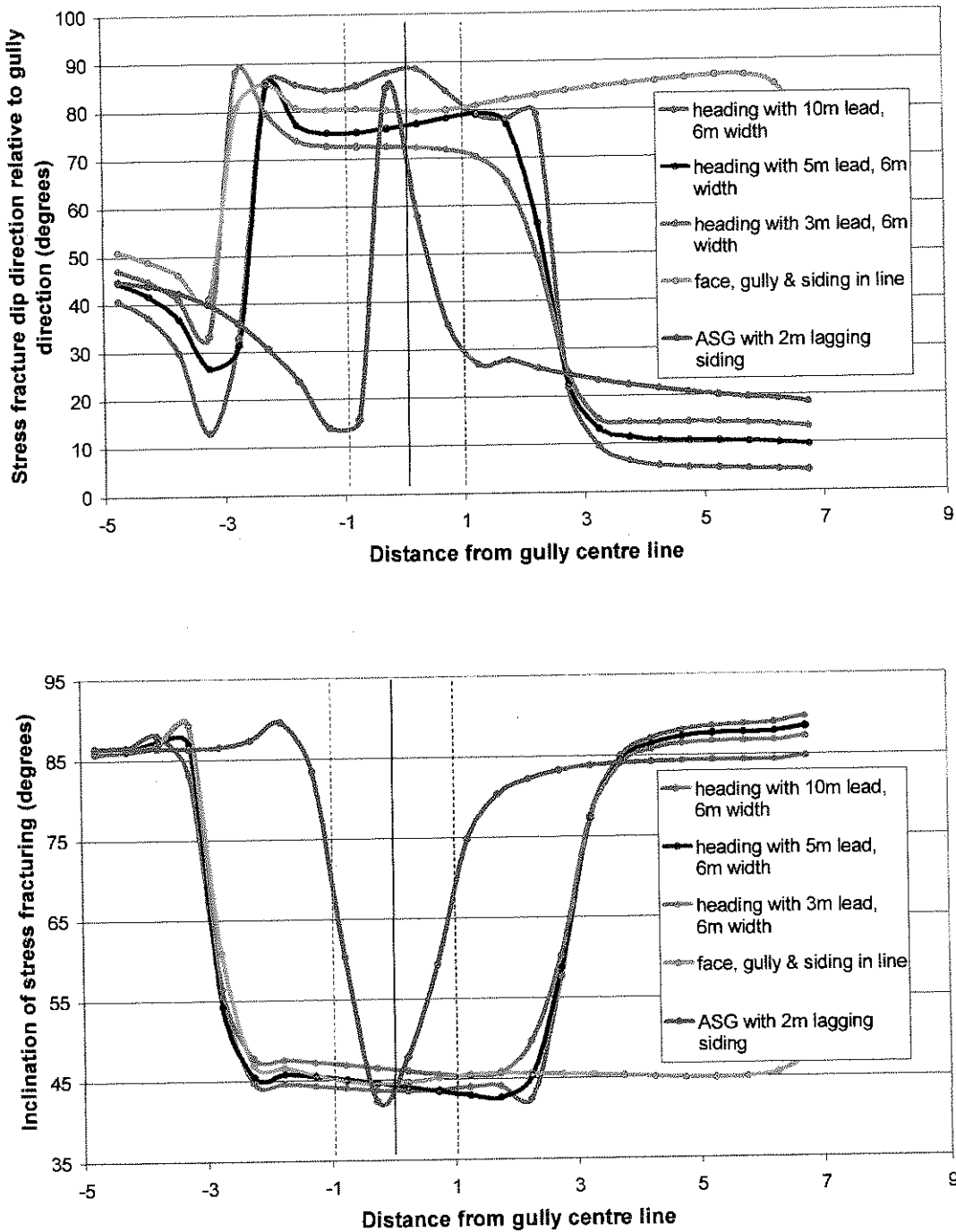

Figure 5.30 – Orientation of anticipated stress fractures in the hangingwall, around the face area of various gullies. Fracture strike relative to gully direction is shown in the upper graph, with fracture dip below. The graphs effectively represent a line of section across the gully

In Figure 5.30 the models indicate a fracture dip of 45 degrees, nearly parallel to the face of the heading (90 degrees to gully direction) on the gully centre line. This is not dissimilar to fracturing generally observed at Tautona on the Carbon Leader Reef, where the quartzite middling to the Green Bar shale is thick. However, in the models, the anticipated fracture orientation turns very sharply to parallel the gully at the edge of the heading, or ASG, or down dip siding in the in-line case and steepens to 85 degrees.

There is no particular indication of flat fracturing around the down-dip edge of the siding (in the heading or in-line cases) in these models, and no particular back-up for observations made by Turner in 1987 that some form of in-line gully case would be preferable to the use of a heading. The heading cases in Figure 5.30 reflect varying degrees of lead, and there is little obvious change in probable fracture orientation, based on stress orientation, as lead is increased or decreased.

Overall, the single mining step models confirm the impression, from both underground observations and the two dimensional models, that any form of ASG with a lagging siding is going to result in conditions that are poorer than those in a wide heading. Strain values reported here indicate a difference of 30%, probably reflected in practice in more fractures, greater dilation of fractures, and higher inelastic movement.

5.4.2.3 Influence of siding lag on gully stability

From Figures 5.27 and 5.28 it was clear that the distance that the siding is permitted to lag behind the gully and stope face does influence conditions in a gully. Figure 5.31 shows this more clearly, also comparing cases for 2000 m and 3000 m depth. Strain data is presented for point 1, in the rock mass that becomes the down dip gully shoulder, and point 3, on the up dip side. The figure compares the difference between the cases where the gully is permitted to lag behind an ASG, and where a wide heading is cut and the siding is, effectively, cut ahead of the gully, rather than lagging behind it. Zero lag occurs where stope face, gully and siding are in line.

Figure 5.31 shows that sidewall shoulder damage is clearly least if the siding is cut in advance of the gully. If the siding, gully and face are brought into line there is an increase in damage in the gully shoulder rock mass, which increases further as the siding is permitted to lag behind the gully and stope faces.

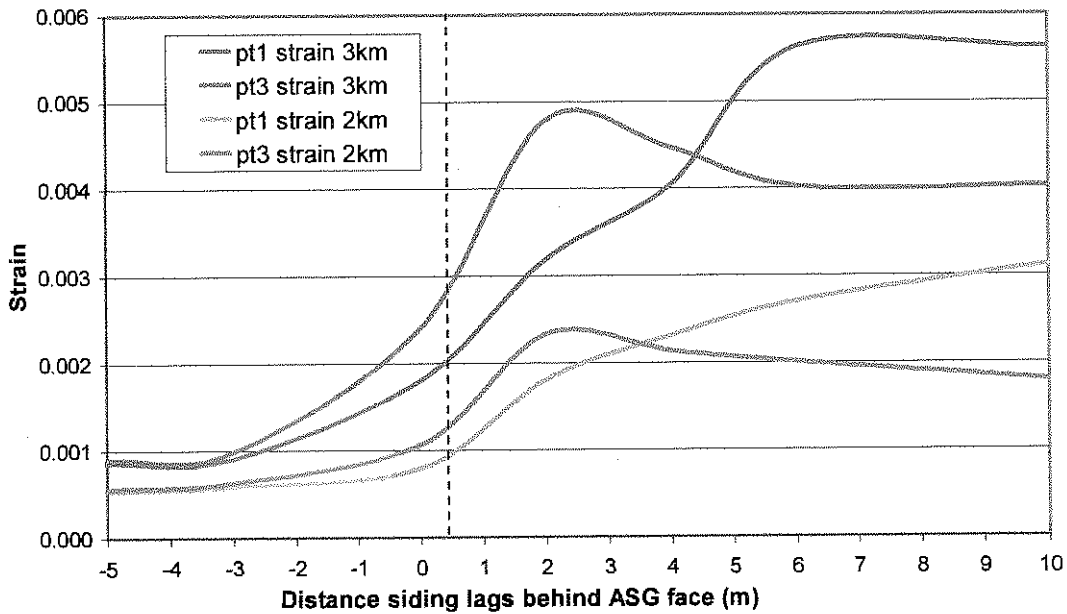

Figure 5.31 – The influence of siding position on gully sidewall conditions. Where the distance is negative, the siding is cut ahead of the gully, as in the case of a wide heading. Where the distance is positive, the siding is cut behind the gully, as in the case of an ASG with lagging siding. At zero distance, siding, gully and stope face is in-line. (See Figure 5.24 for position of points 1 and 3)

On the down dip side of the gully, Figure 5.31 shows that any lag starts to induce an increasing amount of strain in the sidewall rock mass. There is a sharp increase from no lag to 6 m lag, particularly in the 3000 m depth case. Further than 6 m there is little additional increase in strain. The implication is that if an ASG layout is used then sidings should be cut closer than 6 m from the face if worse case stress-induced damage is to be avoided.

Interestingly, the damage induced in the up dip shoulder decreases as the siding lag distance is increased beyond 2 m. This is almost certainly span dependent. In effect, as the siding cutting is delayed there is more solid rock around to bear load, hence reducing loading in the up dip area. On balance, underground observations would indicate that the damage induced on the down dip side is the primary concern, and designs should aim to minimise lag distances.

5.4.2.4 Influence of wide heading geometry on gully stability

The models indicate that a linear relationship exists between the width, in the dip direction, of a wide heading and strain in the gully walls. Figure 5.32 shows the relationship for point 2, where hangingwall damage over the gully is incurred, however a similar relationship exists for all points where data was recorded. Over the range in widths examined, there is not obviously critical width where damage gets either suddenly worse or better.

The probable stress fracture orientations that would form around each width of wide heading are shown in Figure 5.33. There is no apparent tendency for greater fracture curvature around the heading as width is adjusted. In all cases fractures would be face-parallel with 45 degrees dip across the gully, turning sharply to parallel the gully along the heading edges.

Within the range in spans modelled, from 5 m to 8 m, there is no indication of any limiting or optimal heading width. In general a minimum can be based on a 45-degree rule relating gully depth and width to minimum heading width, similar to the relationship for a footwall lifted gully in section 5.3.

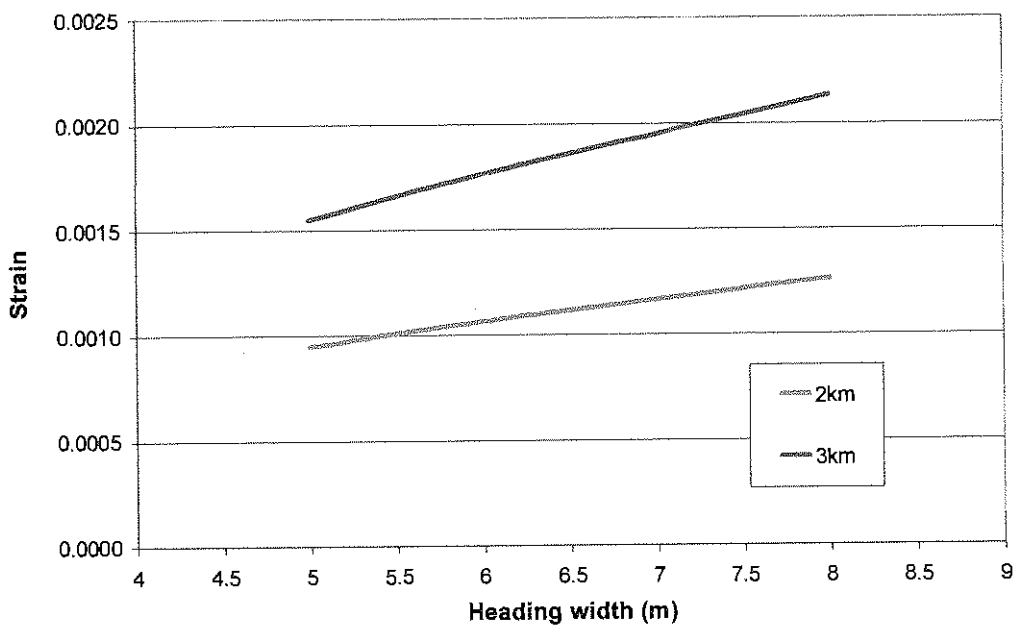

Figure 5.32 – The influence of the width of a wide heading on strain induced in the hangingwall of the gully at the heading face

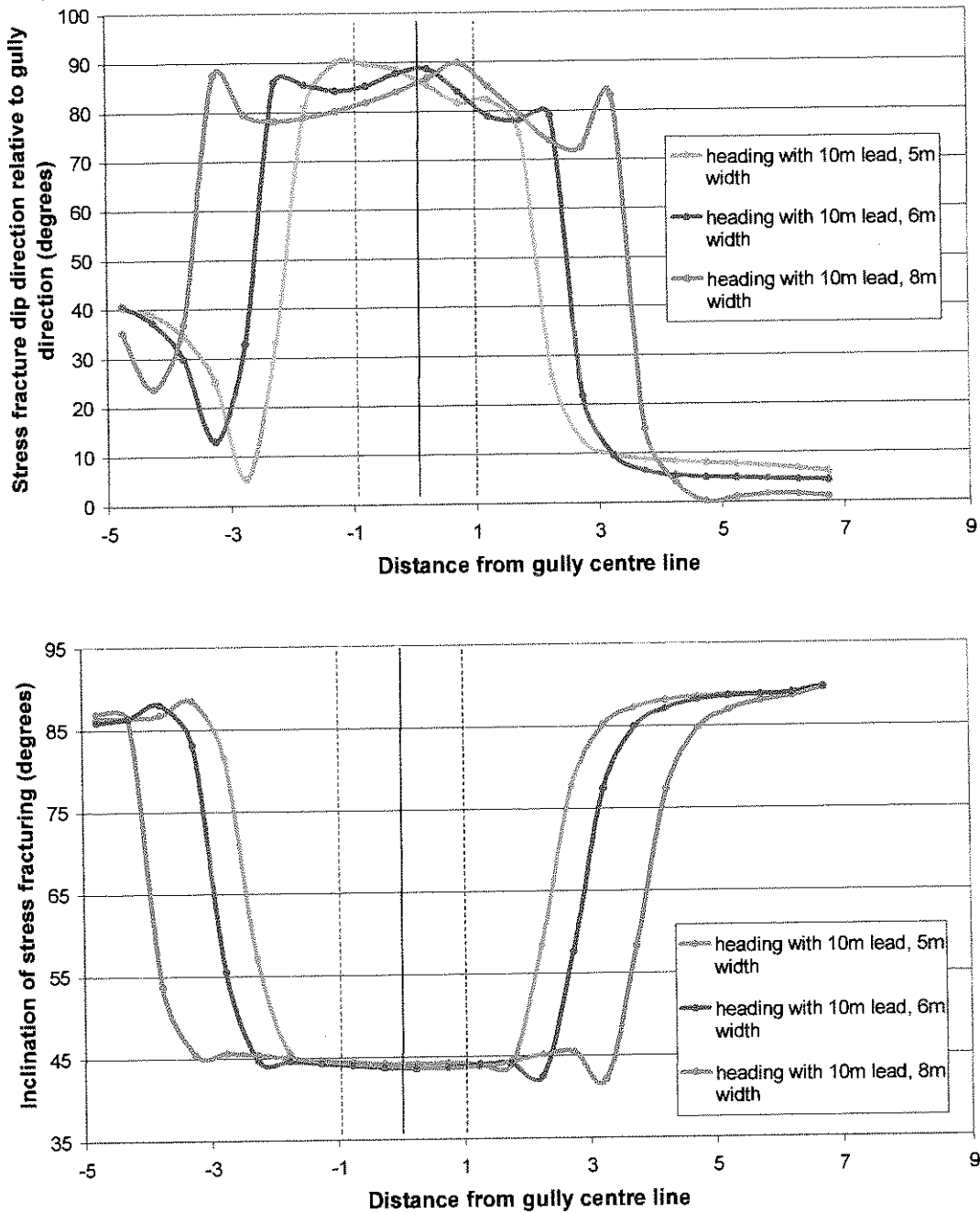

Figure 5.33 – Orientation of anticipated stress fractures in the hangingwall, around the face area of various widths of wide headings. Fracture strike relative to gully direction is shown in the upper graph, with fracture dip below. The graphs effectively represent a line of section across the gully

A further issue for wide headings is the influence on stability of the distance that the heading is allowed to lead the panel face. Figure 5.34 indicates the effect that lead has on the strain reported at point 2, just ahead of the gully in the rock mass that will become the gully hangingwall. In general there is a decrease in strain at this point as the lead is increased. This is expected as the heading moves away from the area of influence around the stope. Superficially this appears beneficial, there is also no increase in deterioration at point 4 in the gully hangingwall level with the face. However, there is an increase in stress in the corner between the wide heading and the stope face and along the up dip abutment of the heading. In practice this would result in more difficult mining conditions in the stope face as the panel is advanced along the top of the leading heading.

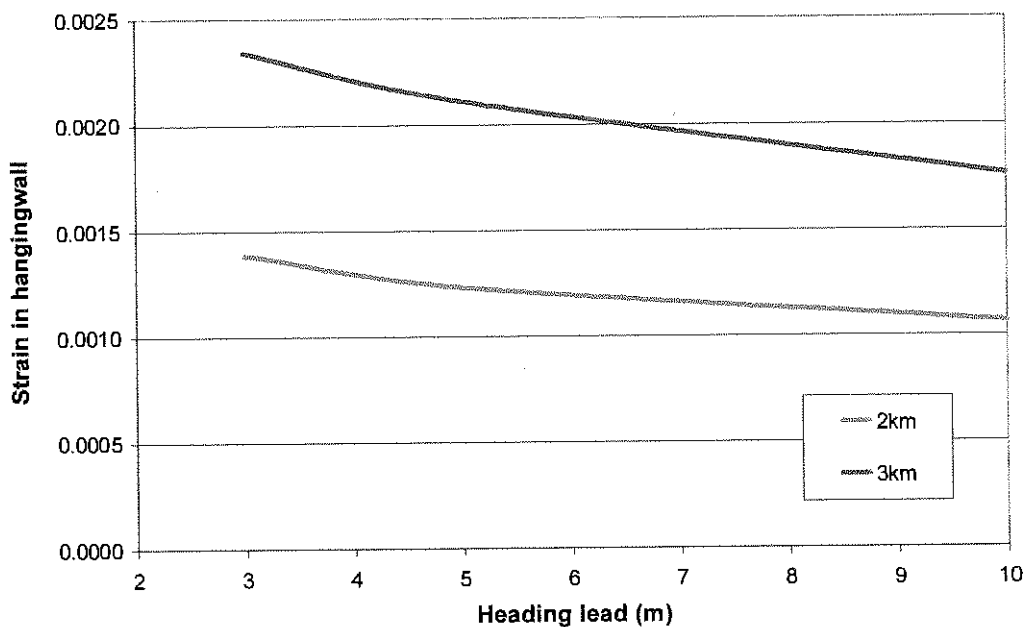

Figure 5.34 – The influence of wide heading lead distance ahead of the stope panel on strain induced in the hangingwall of the gully at the heading face

5.4.3 Multi step FLAC3D models

5.4.3.1 Analysis method

The four cases examined in the multi-step models included two wide heading cases (6 m and 7 m wide), a case where siding, gully face and stope panel face are all in line (best case from the two dimensional models) and an ASG with a lagging siding representing the most likely worst case. All models represent 2000 m depth.

In the two wide heading cases, one carried a 2 m siding either side of the 2 m wide gully, while in the 7 m wide case, the up dip siding width is increased to 3 m. This was done as it was observed that possible stress damage was induced in the gully floor with the narrower case.

In similar fashion to the single step models, in the multi-step models strains, deformations and stresses were monitored at a series of points in the gully walls as mining advanced towards and past them. The set of the monitoring points is shown in Figure 5.35. They were sited in a detailed section of the model where finer zone sizing was used, centred on the stope gully. Points were placed in each shoulder of the gully, down dip and up dip, plus in the gully hangingwall.

A concern with the previous, single step models was that if strains and stress values are only examined at points considered to be damage initiation points, the final extent of damage is possibly not appreciated. By tracking changes as the stoping advances this limitation has been eliminated.

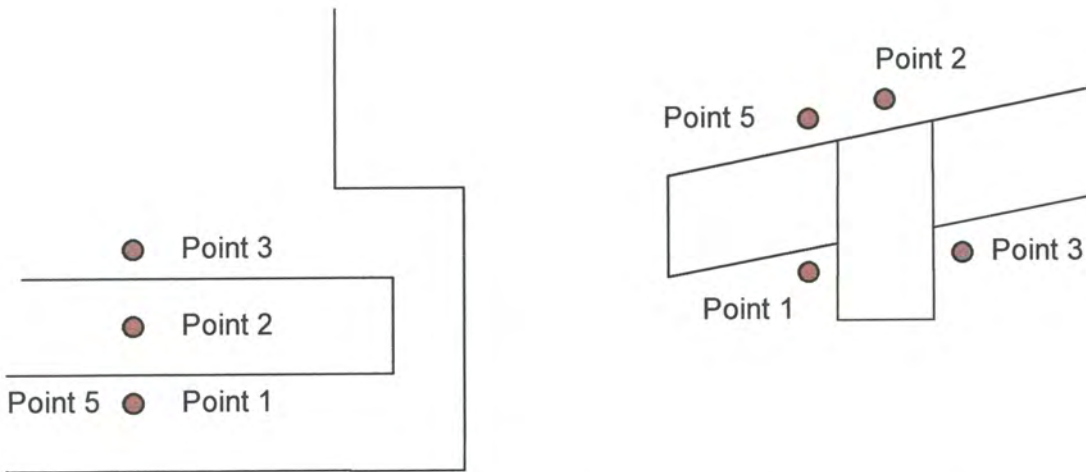
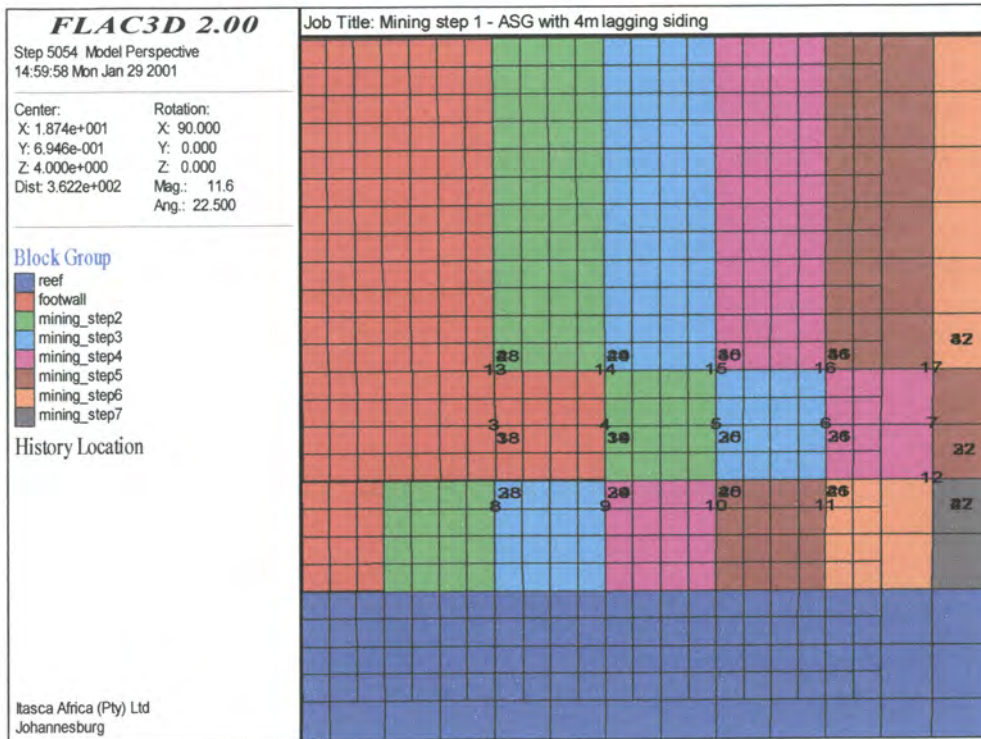

Figure 5.35 – Sequence of advance in the ASG case (top), showing points at which strains, stresses and closures across the gully were monitored. Lower points shows numbering used in this report for the sequence of points within each monitoring ring

5.4.3.2 Comparison of behaviour in multi-step models

Figure 5.36 compares the stress induced in four monitoring points in the sidewalls and hangingwall of each gully modelled throughout the mining sequence. All four models are contained in one graph for ease of comparison. In each model, in mining step 1 the monitoring points lie approximately 6 m ahead of the gully or heading face and by step 10 they lie 14 m behind the face in the mined out area.

The stress data for each model shows a similar trend, with high stress levels when the monitoring points lie in the solid ahead of the advancing gully face, peaking just ahead of the face then dropping to lower values once the mining face advances past.

Stresses reach the highest values in the case where gully, panel and siding are in line (at all points around the gully). A similar value to peak stress is reached in the corner ahead of the lagging siding (point 5) in the ASG case, although stress values around the ASG face is less. In the wide heading case the peak stresses are lower as the heading lies 10 m into solid ground ahead of the stope face. A 7 m wide heading shows higher stress peaks than a 6 m wide case.

After the face passes the monitoring points there is a general reduction in stress. The immediate decrease in stress in the hangingwall is greatest in the wide heading models, but returns to values similar to those in the other two cases as the panel mines alongside the 10 m leading heading. While the monitoring points still lie within the 10 m heading, the stress in the up dip gully shoulder remains fairly high, at 20-30 MPa, only dropping once the panel mines past. The up dip shoulder stress is a little higher in the 6 m wide heading case than in the 7 m case.

The changes in strain at the monitoring points in each of the models are shown in Figure 5.37. These are of similar magnitude to the strains reported in the single step three-dimensional models.

Strains in the two wide heading models in Figure 5.37 are nearly identical and generally lower than the other two models. The differences in strain at the four monitoring points in sidewalls and hangingwall are comparatively small.

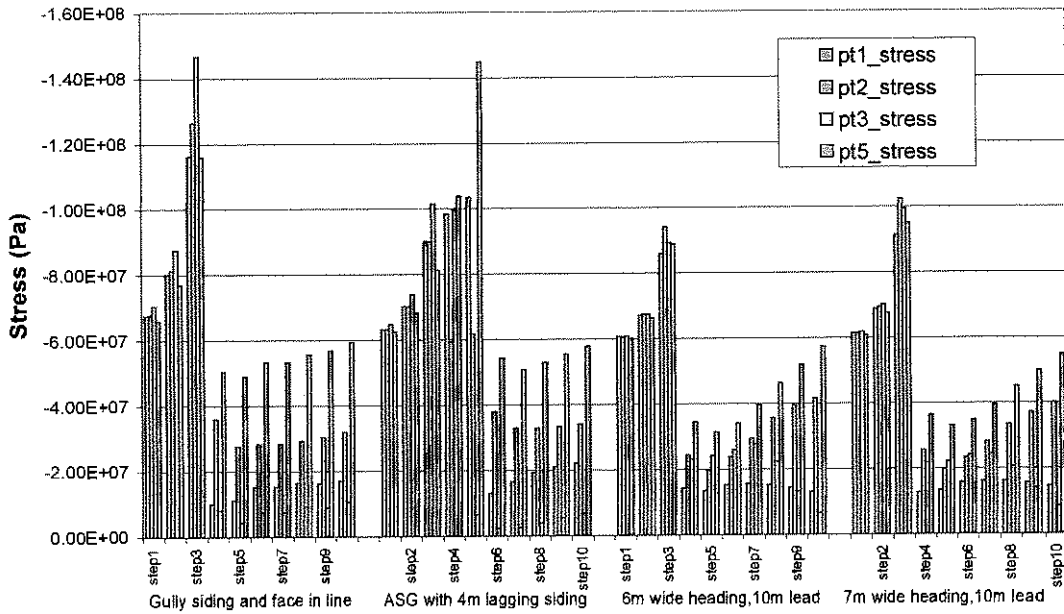

Figure 5.36 – Comparison of stresses induced at monitoring points in the four sequentially mined models. Four points in one monitoring ring are shown for each mining step

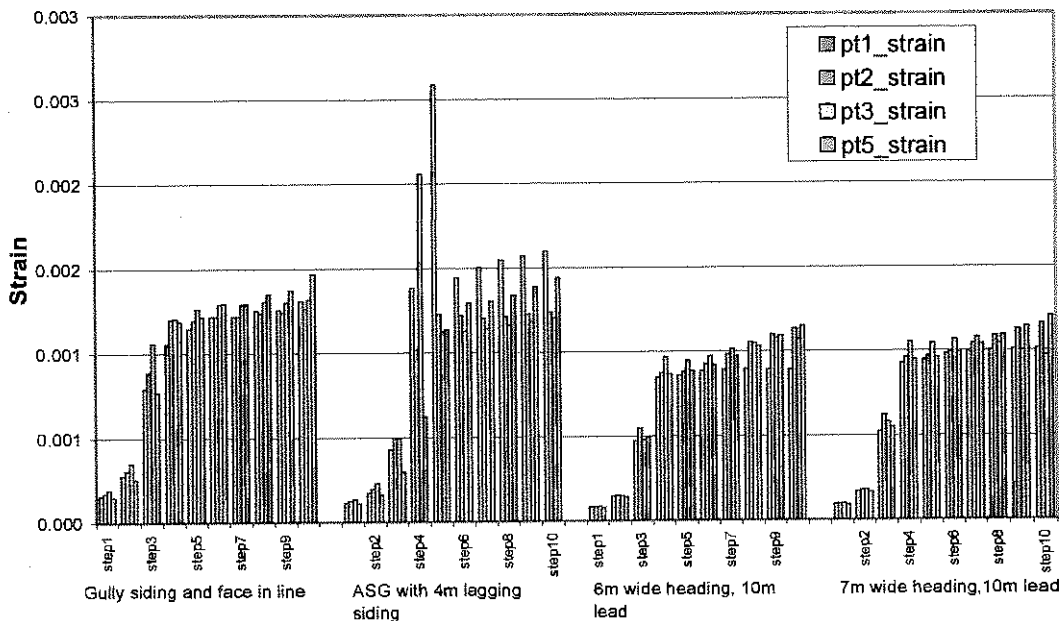

Figure 5.37 – Comparison of strains induced at monitoring points in the four sequentially mined models. Four points in one monitoring ring are shown for each mining step

In the two wide heading cases, strain increases rapidly at the face, then levels off once the monitoring points are behind the face in the mined area. Thereafter there is a slow increase in strain recorded at the hangingwall points (points 2 and 5). In the case of the 6 m heading, the up dip shoulder strain (point 3) also continues to increase slowly, while staying constant in the 7 m case.

When the gully, siding and panel are in line, the development of strains follows a similar pattern to the wide heading case, except that strains are approximately 25% greater. Again there is little difference between the various sidewall and hangingwall points.

The ASG with lagging siding is the only case that is significantly different. Strains in and over the down dip gully sidewall (points 1 and 5) show strains that are generally 50% greater than the wide heading cases, with peak strain, just prior to cutting the siding, exceeding a 100% increase. There are great differences in strain values at the four points in the sidewalls and hangingwall.

In addition to stress and strain values, both horizontal closure across the gully and vertical hangingwall movement was recorded at each mining step at the monitoring points (Figures 5.38 and 5.39).

In terms of vertical movement the two heading cases show the lowest rate of increase in hangingwall movement, with the 6 m case being least due to being the shortest span. The most hangingwall movement close to the face occurs in the lagging siding case.

Horizontal closure values in Figure 5.39 are less expected. Close to the face, the least closure occurs in the lagging siding case. The highest closures are associated with the wide heading cases. The values are highest while the monitoring point lies within the 10 m leading length of wide heading, thereafter closure is reduced as the stope face mines along the up dip side of the heading. It appears likely that all closures tend to similar values far back from the face.

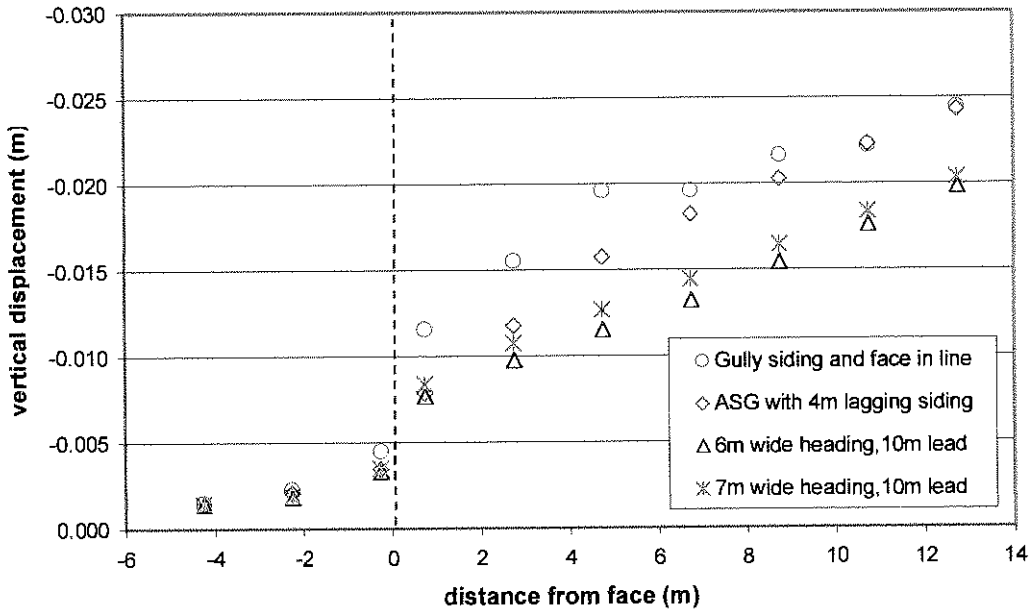

Figure 5.38 – Change in vertical displacement in the hangingwall over each gully as mining advances

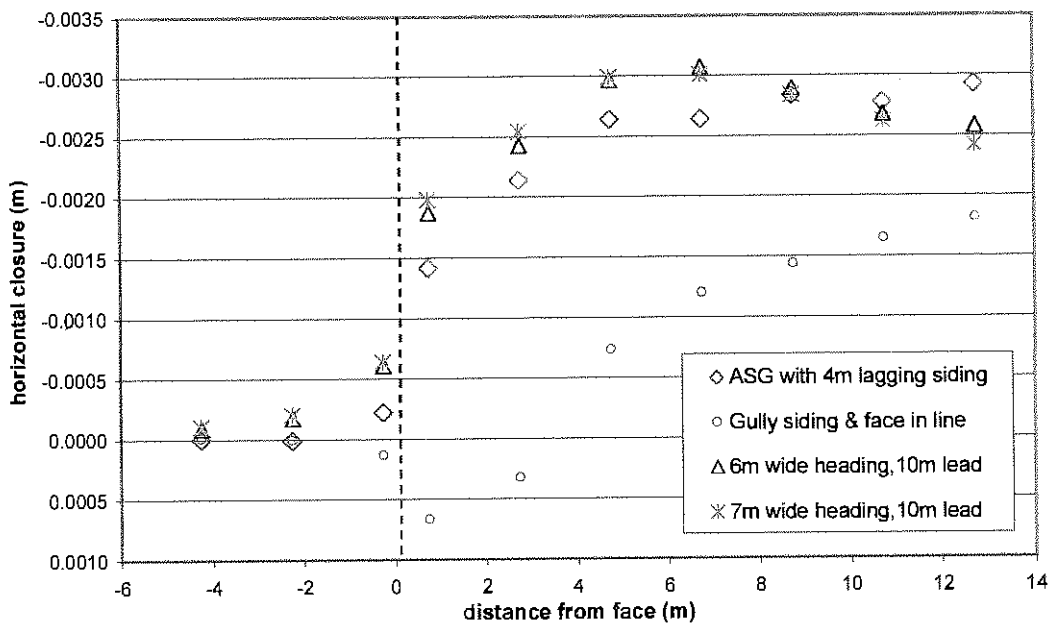

Figure 5.39 – Changes in horizontal closure across each gully as mining advances

5.5 Broad conclusions derived from numerical models

The following broad conclusions can be drawn from the two and three-dimensional numerical models that have been run as part of this project.

At shallow depth:

1. In mining layouts where pillars are used, a siding is desirable if any form of stress fracturing develops in the pillars (i.e. where crush pillar systems are used).
2. The ideal siding width from gully to pillar in shallow crush pillar workings is 2 m. Smaller sidings are ineffective, both as a means of improving pillar performance, and as a way of decreasing gully sidewall damage.

At moderate to deep mining depths:

1. When stresses are high enough to induce fracturing any method where a siding is omitted from the down dip side of a gully with solid down dip, or the siding is permitted to lag is not desirable. There appears to be between 30% and 50% more rock mass strain (damage) than when using other methods. In addition, the induced fracture orientations are more difficult to support.
2. Increase in reef dip tends to increase stresses in gully sidewalls. Hence gullies without sidings become more highly loaded and, in an overhand configuration, footwall lifted gullies at the top of panels need to be sited further from the abutment.
3. Footwall lifted gullies in a overhand stoping layout should be positioned according to a simple 45 degree rule that relates distance from the abutment, gully depth and reef dip.
4. In an underhand, or lowest panel in longwall, situation the two dimensional models indicated that a method where stope face, gully and siding were all excavated simultaneously was preferred. Second choice would be a wide heading.

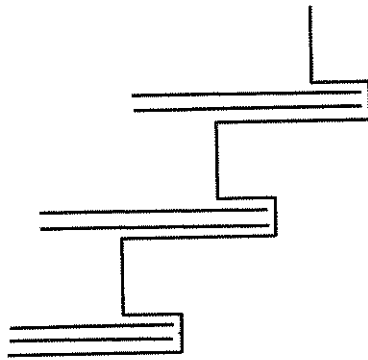

GOOD

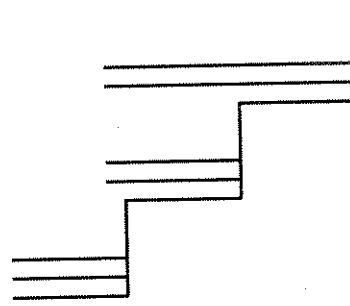

BETTER

5. The three-dimensional models confirmed that lagging sidings and no sidings are not desirable at depth. Wide heading methods appear to be the best option for underhand mining layouts. Damage around the gully appears to be minimised under these conditions. The inline stope face case appears to be second preference.
6. Wide heading leads of up to 10 m appear to not give any obviously detrimental effects. In general, less damage was done in gully walls and hangingwall as the lead was made longer.
7. Heading widths from 5 m to 8 m were examined. No obvious limitations to width were seen. In practice, anything less than 6 m wide is liable to cause damage to lifted gully sidewalls within the heading.
8. If an ASG with a lagging siding is used, the siding should be cut within 6 m of the ASG heading face.

CHAPTER 6 – CONCLUSIONS AND RECOMMENDATIONS FOR GULLY PRACTICES

This section provides broad recommendations for best practices for stope gullies at various depths. The project has not attempted to develop any new techniques for gully protection. A vast number of practices and local adaptations of gully geometries and support methods are in use across the industry or have been experimented with historically. The report has attempted to pull this experience together into a single document, from which it is possible to derive a guide to the practices that are best adopted under various geotechnical conditions. Practices have been assessed through observation and discussion on the mines, and numerical models have been used to provide quantification of certain practices, where uncertainty existed. The focus is on what is considered to be *best practice*.

6.1 Selection of optimal gully geometry

Due to differences in rock mass strength and probably also to overall in-situ stress regime, stress fracture damage is observed at shallower depths, generally, in the Bushveld Platinum Mines than in the Witwatersrand Basin gold mines. Most of the platinum mines use pillar-based support systems, in which pillar crushing can impact on gully stability. As a result, two guidelines have been drawn up to indicate the preferred gully geometries to use in the two tabular mining districts. The selection of preferred geometry is based on tolerable levels of stress damage and follows primarily from the observations described in section 4.

Given the arbitrariness of current “shallow”, “intermediate” and “deep” level mining conditions, two factors are important in this namely; the virgin stress state (“deep” conditions may be encountered in “shallow” mines) and rock strength (in weak shale, the fracturing and mobility of quartzites only seen at >2000m, may be well developed at <500m c.f. coal mines). A chart is presented in Figure 6.1 subdivided into gold and platinum mines. Thus in each, three areas are defined:

- **Low stress** ($\sigma_1 < 0.15\sigma_c$, where σ_c is the UCS of intact rock) – instability is controlled by geological structure and stress damage is generally not apparent.
- **Moderate stress** ($0.15\sigma_c \leq \sigma_1 < 0.30\sigma_c$) – selected methods must cope with instability resulting from stress fracture interaction with geological structure such as bedding, jointing and weak strata.
- **High stress** ($\sigma_1 \geq 0.30\sigma_c$) – conditions where stress induced fractures are the dominant and most densely spaced discontinuities, in many instances making geological structure inconsequential. Seismicity is often a concern.

The exact limits of these class intervals are not fixed and may change from one situation to another.

In terms of stress, the depths in Figure 6.1 can be translated into the Maximum Principle Stress levels shown in Table 6.1 for the in-situ field stresses. In each case there are areas of overlap from 200 m to 400 m (5 to 10 MPa in terms of field stress), which result from variable competencies of the local strata.

Table 6.1 – Stress categories used for gully selection

	Platinum Mines		Gold Mines	
	Depth Range	Maximum Field Stress Component	Depth Range	Maximum Field Stress Component
Low Stress	< 750 m	< 20 MPa	< 1200 m	< 30 MPa
Moderate Stress	500-1500 m	14-40 MPa	1000-2200 m	27-60 MPa
High Stress	> 1200-1500 m	> 35-40 MPa	> 1800-2200 m	> 50-60 MPa

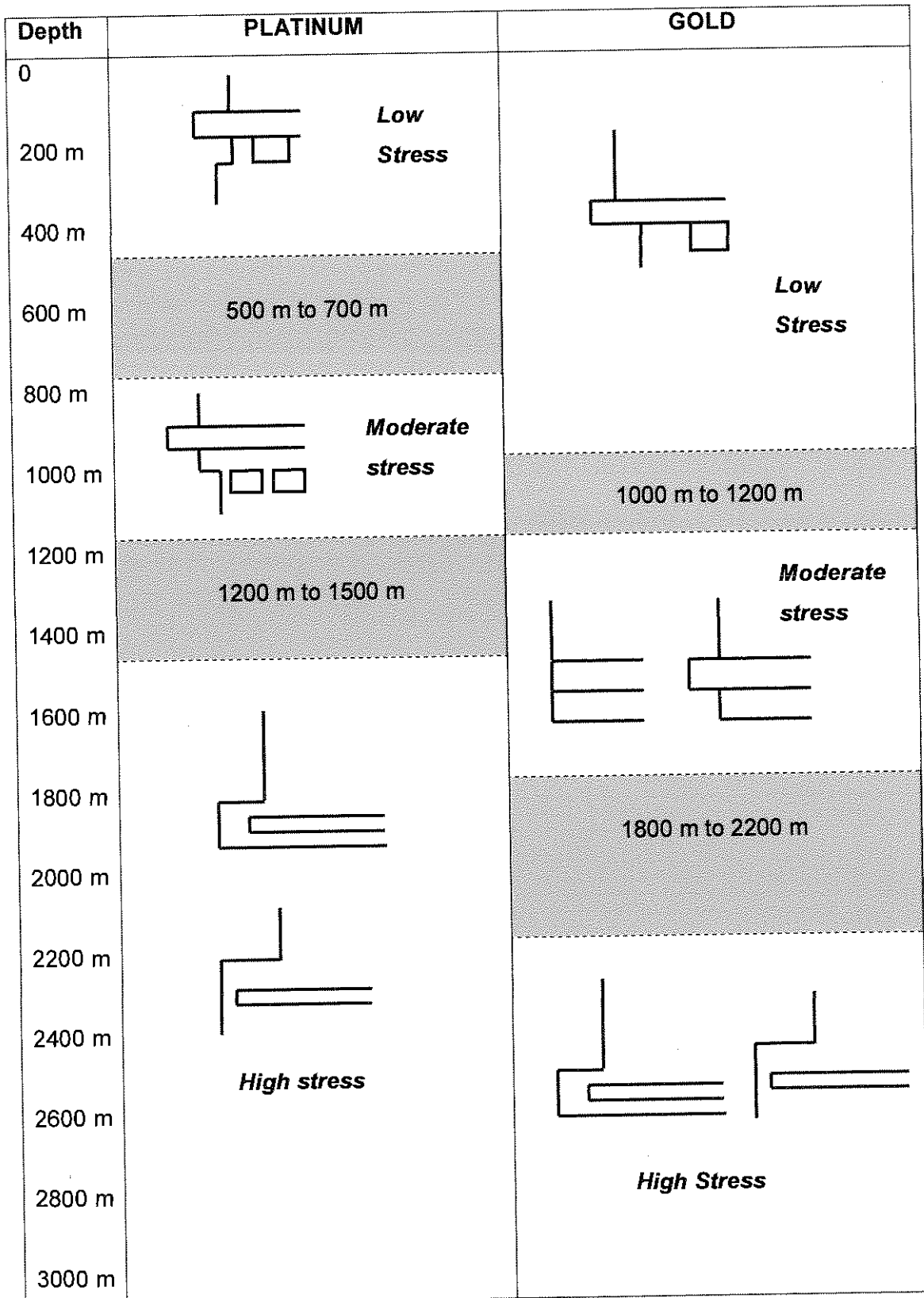

Figure 6.1 – Recommended gully geometries as a function of mining depth in gold and platinum mines

6.2 Recommendations for low stress conditions

6.2.1 Options for gully geometry

A narrow ASG with width less than 2 m can be used. No siding is required. If the geology of the reef and hangingwall is not problematical, the gully can sit directly on the edge of pillars if the pillars are designed to be stable. Pillar stability calculations should assume pillar height to be equal to stoping width plus gully depth

If pillars are designed to crush, the mine should make observations of damage incurred in pillars and the gully sidewalls and hangingwall. If a risk of injury from falls of ground is apparent, or if pillar stability is compromised, the gully should be moved 2 m from the pillar (i.e. a 2 m siding should be cut). A smaller siding is ineffective and merely serves to widen the span over the gully and make conditions more hazardous.

In genuine low stress conditions where no stress deterioration is observed the ASG can lead the stope face by any distance required for practical mining operations, including being driven far ahead for exploration purposes.

Care should be taken to cut the ASG with its hangingwall on the reef top contact. This prevents breaking through any bedding and introducing geologically bound hazards (e.g. brows on the updip side as seen at Beatrix Mine).

6.2.2 Support practices

6.2.2.1 Specification of support requirements

Support requirements in low stress areas depend on local geological structure. Where reef parallel partings exist in the hangingwall, support should be installed on a spacing designed to provide adequate support pressure to suspend the beam over the gully. Appropriate areas to estimate support pressure over for the gully edge (elongates) and gully hangingwall (tendon) units are shown in Figure 6.2.

6.2.2.2 Selection of support

Where stope width is less than approximately 2 m it is likely that in-stope support will comprise some form of pre-stressed elongate or stick. At higher stope width, it is

likely that hangingwall bolting will be used in the panel. A similar choice applies to gully edge support. Pre-stressed elongates or sticks should be used along the gully shoulders at shallow depth. Closure rates are low and a rigid unit is required. These should be installed up to 0.5 m from the gully wall, depending on wall competency.

Where stope width exceeds 2 m, the tendon pattern used in the panel should be extended across the gully area, with additional tendons installed to make safe as required.

Where a reef-parallel parting exists in the hangingwall of the gully, and the resulting beam is 30 cm or less, tendons should be installed in the gully hangingwall. Length depends on the number of partings in the hangingwall and the vertical spacing, but longer units than 1.2 m are unlikely. Spacing depends on the dead-weight of the beam.

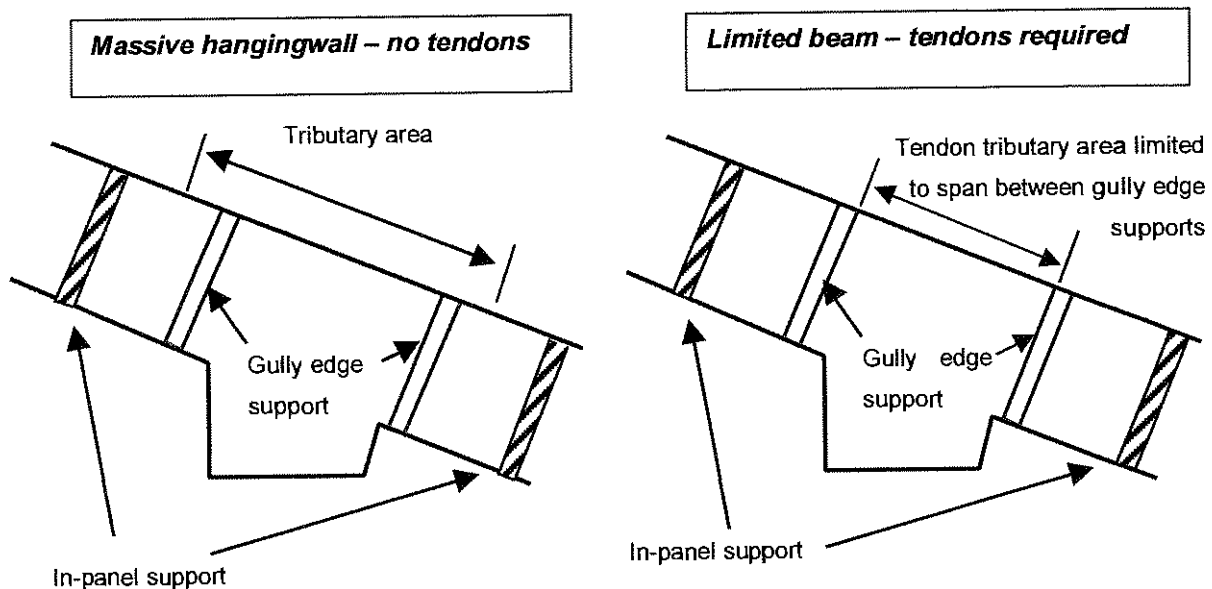

Figure 6.2 – Recommended tributary areas for calculation of required gully support pressures in low stress mining areas

For strata beams in excess of 30-50 cm thick, in the absence of frequent jointing, it is likely that they are adequately rigid to require no tendon support over the gully in a low stress environment. Support for these beams must be provided by the gully edge support.

If gully edge support is considered inadequate additional pillars should be left on both sides of the gully to keep the gully span to a minimum. Reasons for inadequacy of gully edge support might include unstable gully shoulders, locally increased levels of jointing, a dome edge (in a Bushveld mine), or inability to achieve a high enough support resistance with gully edge support.

Where hangingwall tendons are required, a pretensioning mechanism is considered essential, but grouting is probably only required where conditions are wet or very long term stability is required.

6.3 Recommendations for moderate stress conditions

6.3.1 Options for gully geometry

6.3.1.1 Narrow ASG headings

ASG headings remain acceptable, but should not be advanced far ahead of the stope face: 2 m is probably a maximum value, 1 m or less is preferable. This distance should be such that any stress fracturing parallel to the stope face remains predominant. If stress fracturing is observed parallel to the ASG walls, then the ASG is advanced too far. While a scraper over-run ahead of the face is often desirable, many mines have successfully cleaned stope faces when the ASG and stope face are in line.

6.3.1.2 Sidings

Sidings should be cut whenever stress fracturing is apparent. Without sidings flat dipping fractures will develop from the solid abutment over the gully and lead to instability. While additional support is a feasible alternative, first preference should be to choose a geometry that alters the stress fracture geometry. In mines using in-stope pillar systems, pillars will almost certainly exhibit stress damage in sidewalls, and probably limited shearing in the hangingwall. Sidings are important for both gully and pillar stability.

Lagging sidings are not recommended in any environment but can be tolerated where the hangingwall strata is massive and competent (e.g. strong Ventersdorp Lava, competent pyroxenite). The recommended geometry would be to mine the

stope panel face and siding face approximately in line (within 1 m). Ideally the gully face should also be in line.

If the hangingwall strata are bedded quartzite, sidings must not be allowed to lag. With increasing siding lag, the fractures formed along the down dip side of the gully between ASG face and siding face become increasingly flat and more problematic. Bedding provides a weak parting that flat fractures tend to run into obliquely. Local stresses tend to drive movement along the stress fractures and bedding, compounding hazards. The absolute maximum that a siding should be cut back from the face is 6 m. If flat fractures are observed curving up over the gully hangingwall from the lagging siding corner, and these cause frequent ground control problems, then the siding is lagging too far back from the gully face.

Siding width needs to provide enough space for support, plus a bulking space behind the support for broken rock. As a general rule, sidings should be cut a minimum of 2 m wide, measured from the near edge of the gully, not the centreline. However, if the gully is deep, or is of larger dimension than normal, the required width of siding should be estimated using a simple 45 degree rule (Figure 6.3). Wherever tendons are required in the hangingwall, a minimum gully depth of 1.8 m is required.

Note that the geometries described here should not exclude the use of deep mining techniques such as wide headings, and footwall lifted gullies, if mines so prefer.

6.3.2 Support practices

6.3.2.1 Specification of support requirements

Under moderate stress the ground requiring support is controlled by geological discontinuities such as bedding, and jointing, coupled with the moderate stress fracture damage. Seismicity is a lesser concern in this environment and closure rates are still low to moderate. Design requirements can again be based on a static support resistance calculation, using the same tributary areas shown in Figure 6.2.

6.3.2.2 Selection of support

Because of the risk of some stress fracture damage causing sidewall and hangingwall gully instability, elongates are no longer suitable as gully edge support

and need to be replaced by packs, which, due to their greater cross-sectional area are considerably more stable.

Packs should be moderately stiff, but not so stiff that gully sidewall damage is induced below them. Provided gully wall damage is minimised by using an appropriate layout, there is no need to use a pack with a dip length longer than 1 m on either side of the gully. Packs on the down dip side can be a minimum of 0.75 by 0.75 in stope widths up to 1.5 m. Acceptable pack types include solid timber mats, cementitious brick packs, and end - grain timber composites. Pack pre-stressing is essential because closure rates are rarely high if stress levels are only moderate.

Stress damage will, if the hangingwall is competent, preferentially occur in the plane of the reef in the siding and stope face. In these circumstances, hangingwall tendon support is unnecessary.

Tendons are generally only required where the strata is well bedded. A minimum length of 1.2 m is recommended. Grouted tendons, possibly with an end anchorage to permit tensioning, are probably most suitable. Yieldability is not a major concern unless large movements need to be accommodated. Additional areal coverage of the hangingwall between tendons should generally not be required as primary support under moderate stress.

6.4 Recommendations for high stress conditions

6.4.1 Options for gully geometry

Any form of narrow ASG heading, with an independently cut siding is considered inappropriate for using under high stress conditions. All gullies should be footwall lifted, either within a wide heading, or in the top corner of the leading stope panel if an overhand configuration is used.

For gullies that will be required to remain serviceable for a long period of time adjacent to an abutment, a siding should be used that places the gully a minimum of 6 m from the abutment. Narrower sidings are liable to lead to considerable gully deterioration in the long term. The other option is to seal sections of a near-abutment gully off and replace it with a travellingway further inside the stope. For short term sidings, e.g. in an underhand panel layout, comments in the following sections apply.

6.4.1.1 Wide heading

A wide heading should be cut on reef at normal stope height. It must be sufficiently wide that in the region of the gully and the up and down dip shoulders, stress induced fractures are all near-parallel to the heading face and normal to the direction of gully advance. If fractures curve in either shoulder then the heading is too narrow. On the down dip side a minimum siding width should be 2 m, while on the up dip side a simple 45 degree rule can be devised (Figure 6.3).

The design siding width should be the greater of:

- The 45 degree rule
- Twice the selected gully pack width plus 1 m bulking space, plus gully width
- six metres

There do not appear to be severe limitations to tolerable wide heading leads, at least not from the point of view of damage to the gully itself. However, if the lead is very long, there will be stress fracturing developed around the up dip side of the heading that may cause hangingwall control problems towards the bottom of the stope panel face. Minimum lead could be less than 4 m, giving a small amount of over-run for the scraper in the gully, and 2 m for face support in the heading face area, ahead of the gully lifting. Under normal conditions leads should be limited to a maximum of 10 m.

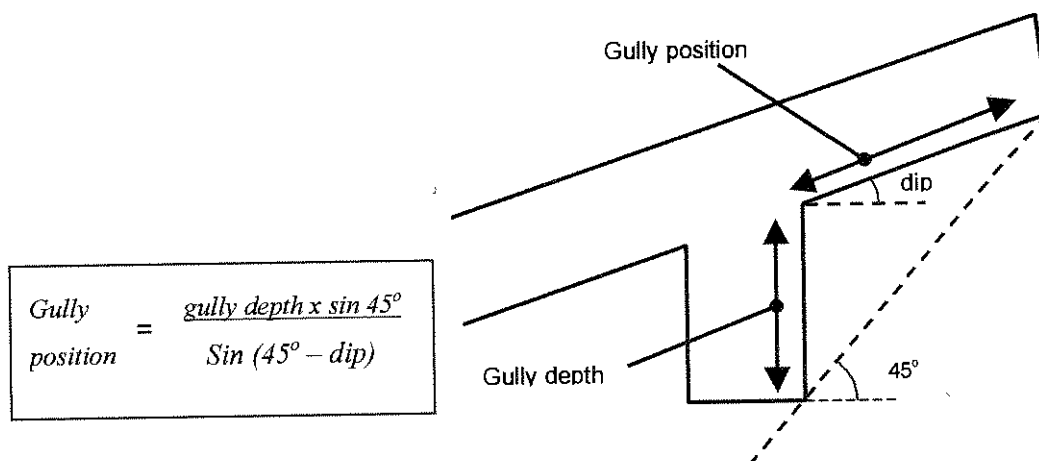

Figure 6.3 – A simple 45 degree rule for siting footwall lifted gullies in an overhand mining configuration

6.4.1.2 Footwall lifting in an overhand stoping layout

In an overhand layout, gullies can all be excavated by footwall lifting, with the exception of the bottom gully in a longwall or raiseline. The gully is excavated by footwall lifting in the leading top corner of each stope panel. The gully needs to be excavated to a point ahead of the lagging panel face. However it must also provide a top escapeway to the lower, leading panel. To do this it should be excavated no further than 5 to 7 m from the stope face of the leading panel.

The gully must be sited away from the strike abutment between leading and lagging panels to avoid flat or curved stress fracturing from developing over the gully. The minimum distance should be the greatest of:

- A simple 45 degree rule (shown in Figure 6.3)
- The selected gully pack width plus 1 m bulking space
- Three metres

Gully depth should be a minimum of 1.8 m, preferably more to ensure that any hangingwall tendons are installed vertically, not inclined.

6.4.2 Support practices

6.4.2.1 Specification of support requirements

Ubiquitous and dense stress fracturing are the key factor of mining under high stress. Geological structure places a lesser role. Seismicity must be expected. Support capacity must be sufficient to support the dead-weight of any thickness of strata considered likely to be unstable, plus the result of any dynamic loading or deformation, imposed on the gully by seismic activity.

6.4.2.2 Selection of support

Under high stress conditions, both gully edge and hangingwall support is required despite every effort to orient stress fractures most favourably. Both packs, and backfill with elongates have proven successful in these gullies.

Packs should be of a long axis type (typical 1.5 m on dip) on the updip side of the gully, with smaller packs on the downdip side. Long axis packs are preferred because the scraper might dig into the updip sidewall beneath packs and undermine their foundations. Depending on local closure rates, packs need not be prestressed, merely blocked and wedged. All packs should be installed normal to dip. Pack spacing along strike should typically be less than 2 m. Packs should be installed on survey lines in the face area of the wide heading or leading panel and the footwall should be lifted between the packs to firm the gully.

It should be noted that an uneven gully floor is regarded as bad practice because:

- the bouncing scraper results in support damage
- cleaning is hampered and is therefore slower
- gold accumulation in hollows in the gully floor becomes difficult to remove, which leads to delayed gold revenue, i.e. a reduction in profits as the gold is only removed in the vamping stage.

Backfill can be brought right to the edge of the gully on both the up dip and down dip sides when mining overhand using footwall lifted gullies. It cannot be brought to the downdip side when a wide heading was used. Prestressed elongates installed at the stope face provide immediate support along the gully edge until the backfill is loaded. Elongates on the gully edge tend to drop out some 10 to 20 m back from the face because of gully shoulder damage. Using backfill in this situation is favoured as it reduces the material transport in the gully.

Tendons should typically be a minimum of 1.2 m long, installed as close as possible to the face of the lifted gully. The spacing of tendons will be dictated by the actual fracture density, but could comprise a 1-2-1-2 or 2-3-2-3 repeat pattern of tendons, with rows spaced at 1 m to 1.5 m intervals along the gully. Where tendon support is inadequate to contain weak ground, sets and cribbing, steel gully liners and even shotcrete or other membranes should be used for gully hangingwall stabilisation, installed as close as possible to the gully face. Where collapses occur and remedial work is required, sets and void filling, and resin injection are the preferred gully rehabilitation options.

6.5 Steep dip

The only area where sidings can be omitted under moderate to high stress is where dip is steep. However if sidings are omitted it must be accepted that very poor conditions will result and severe support measures must be used. In general an overhand layout should be used wherever possible to avoid having gullies with solid ground down-dip.

Geometrically it should be possible to cut a down-dip siding where dip is as steep as 50 degrees, without having it directly under the gully. Cleaning is problematical, and methods to alleviate this problem should be investigated and developed.

If sidings are omitted, tendons and probably strapping should be installed in the down dip sidewall and hangingwall at the face. Where long abutments are mined without sidings, consideration should be given to creating a walkway one or two pack lines up from the abutment so that stope access does not need to be along a gully with a solid siding and stress damage. Tendon lengths should be based on the estimated depth of fracturing in the gully sidewalls or shoulders.

Note that the absence of a siding is preferable to attempting to cut a siding off reef at an easy to clean angle. Such a siding will cause severe loosening and loss of confinement of the immediate hangingwall, particularly where it is well bedded. It will also severely destabilise ground if a panel is to mine immediately down dip of the gully.

6.6 Blasting practice

Much current damage in gullies is exacerbated by poor controls and drilling patterns for drilling and blasting.

Basic rules would include the following:

- Drill holes to the correct length, spacing and straight in the planned direction.
- Do not over-charge holes.
- Get burdens between holes right
- Get detonation timing correct

Specific guidelines for various gully geometries follow.

6.6.1 Wide headings

Wide on - reef heading faces have no free breaking point and hence require a cut to be drilled. Blast fracturing at the cut position is more concentrated than elsewhere in the round and may cause damage to hangingwall strata. Consequently the cut should not be placed in line with the gully face. It should be placed off to the side of the gully where gully packs will be placed. Ideally it would be switched from left to right of the gully, so as not to induce continuous damage along a line.

6.6.2 Footwall lifted gullies

The best practice to ensure that a footwall lifted gully is sufficiently deep, the sidewalls are vertical and the face is square, is to carry out all drilling and blasting operations from within the gully rather than from the stope ahead. Thus all holes are drilled horizontally into the face of the gully.

The stope ahead provides a free breaking point and the preferred practise is to drill a row of holes centrally down the centre-line of the gully face, plus an extra hole in the lower gully face corners. These latter two holes should not be overcharged.

6.6.3 Advanced strike gullies (ASG)

Mining an ASG requires the use of a development type round as the ASG leads the stope face and has no free breaking point. Consequently the round comprises a central cut and perimeter holes. Positioning of the cut is important. It should be close on the gully centreline as if on either side it tends to damage the gully sidewalls. Likewise hangingwall damage occurs if it lies within the top third of the ASG face. Light charges and smooth blasting are advocated for ASG excavation.

6.6.4 Lagging sidings

If lagging sidings must be employed the following is suggested: -

Sidings should be drilled by an operator sitting in the siding and drilling straight ahead into the reef. A lagging siding should always be advanced along strike at a similar rate to the stope face, e.g. a 1m round blasted every other day.

Sidings should not be allowed to lag the face and are then excavated by drilling down dip into them from the gully.

BIBLIOGRAPHY

- ADAMS, G.R., Jager A.J. & Roering, C. 1981. Investigations of rock fracture around deep-level gold mine stopes. Proceedings of the 22nd US Symposium on Rock Mechanics: Rock Mechanics from Research to Application, Massachusetts Institute of Technology :213-218.
- ADAMS, D. J., Kullman, D. & Sello, O. Evaluate current alternatives to conventional gully pack support for an ultra-deep mining environment. Deepmine Task 4.3.1, Report no. 99-0162, CSIR Mining Technology, 28 February 1999.
- ANGLO AMERICAN CORPORATION GOLD AND URANIUM DIVISION. 1992. Reference manual for mine geologists volume 1. Johannesburg.
- APPLEGATE, J. D. 1991. Rock mechanics aspects of sequential grid mining. M.Sc. project report. University of the Witwatersrand, South Africa.
- ARNOLD, D.A.; Legg, E.W. & Roberts, M.K.C. 1994. Reducing the unsupported stope span at Hartebeesfontein Gold Mines, XVth CMMI Congress, Johannesburg, SAIMM, 1:159-165.
- BAKKER, D. 1995. Safety at the stope face, Mine Safety Digest No.2.
- BAKKER, D. & Rymon-Lipinski, W.K. 1992. Rockfall/Rockburst accidents: A new approach by the Government Mining Engineer. Mine Safety Digest No.2:18-21.
- BROWN, A.A. & Noble, K.R. 1994. Engineered gully support. Mine Safety Digest, No. 5:24-26.
- BUDAVARI, S. 1983. Rock mechanics in mining practice. The South African Institute of Mining and Metallurgy Monograph Series M5.
- BUTLIN, C.L. 1930. Shovelling and tramming and ore transport – use of mechanically operated scrapers in workings of flat dip at the Modderfontein “B” Gold Mines Ltd. Third (Triennial) Empire Mining and Metallurgical Congress, Johannesburg, South Africa.

CHAMBER OF MINES OF SOUTH AFRICA. 1977. An industry guide to the amelioration of the hazards of rockbursts and rockfalls. Compiled by the High-level Committee on Rockbursts and Rockfalls.

COGGAN, J.S. 1986. Support Practices in Klerksdorp mining district. Unpublished Proceedings: Stope Support seminar, Chamber of Mines Research Organisation, Johannesburg.

COMRO, 1992. Analysis of falls of ground and rockburst fatalities in gold mines. Mine Safety Digest No.2.

COMRO. 1988. An industry guide to the methods of ameliorating the hazards of rockfalls and rockbursts, 1988 Edition.

COOK, P.J., Lewis, B. & Pienaar, P. 1994. An effective face area support system. Mine Safety Digest, No. 1.

COOK, N.G.W., Klokow, J.W. & White, A.J.A. 1972. Practical rock mechanics for gold mining. Chamber of Mines of South Africa publication, PRD Series No. 167.

COOK, N.G.W. & Salamon, M.D.G. 1966. The use of pillars for stopes support. Chamber of Mines of South Africa Research Report No.43/66.

DIERING D H. 1987. Regional support at Western Deep Levels Limited. Association of Mine Managers of South Africa: papers and discussions, 2/87:1-74.

DUNN, M.J. & Laas, J.J. 1999. The panel rating system – a risk management tool. SARES 99: 2nd Southern African Rock Engineering Symposium, Johannesburg, 13-15 September 1999.

DURRHEIM, R.J., Roberts, M.K.C., Halie, A.T., Hagan, T.O., Jager, A.J., Handley, M.F., Spottiswood, S.M., Ortlepp, W.D. 1998. Factors influencing the severity of rockburst damage in South African gold mines. SAIMM Journal, 98 (2): 53-57.

ESSRICH, F., Amidzic, D. & Hammann E. 1999. The influence of backfill on seismicity in the AngloGold West Wits Operations. SARES 99: 2nd Southern African Rock Engineering Symposium, Johannesburg, 13-15 September 1999.

FOUCHE, F.A.B. 1954. Some results obtained through changes in stoping methods on Robinson Deep Ltd. Association of Mine Managers of South Africa: papers and discussions :413-428.

GAY, N.C., Jager, A.J. & Roberts, M.K.C. 1988. The control of falls of ground and Rockburst damage. Loss Control Survey, 7 (3), August:11-32.

GAY, N.C. & Ortlepp, W.D. 1979. Anatomy of a mining induced fault zone. Bull. Geol. Soc. Am., 90:47-58.

HAGAN, T.O. 1987. An evaluation of systematic stabilising pillars as a method of reducing the seismic hazard in deep and ultra-deep mines. Ph.D. thesis, University of the Witwatersrand, Johannesburg.

HAGAN, T.O. & Grobbelaar, D.M. 1984. Interim report on a study of mining-induced fracturing across a strike stabilising pillar. Rockburst research project report No. RP 94, Anglo American Corporation, Research and Development Services, Rockburst Research Project, Western Deep Levels Limited.

HOBDAV, H. & Leach, A.R. 1992. Some case studies in rock engineering: application on Western Deep Levels South Mine; SANGORM symposium: Impact of Rock Engineering on Mining and Tunnelling Economics.

ITASCA Consulting Group Inc. FLAC Fast Lagrangian Analysis of Continua. User's Guide. Second Edition, August 2000.

ITASCA Consulting Group Inc. FLAC3D Fast Lagrangian Analysis of Continua in 3 Dimensions. User Manual. 1997.

JAGER, A.J. & Ryder J.A. 1999. A handbook on Rock Engineering Practice for tabular hard rock mines. SIMRAC, Johannesburg.

KERSTEN, R.W.O. 1969. Structural analysis of fractures around underground excavations on Witwatersrand gold mine. M.Sc. thesis, University of Pretoria.

- LEACH, A.R. 1993. Support of trackless roadways in a high seismicity environment. Presentation at seminar entitled "Tendon support into the 21st century", Iscor Club Pretoria. 1993
- McGARR, A. 1971. Violent deformation of rock near deep level tabular excavations, Bull. Seis. Soc. Am., 76 (29):7088-7105.
- MERSON, A., Gerber, T.J., Brinch, G.H., More O'Ferrall, R. & Cloete, D R. 1976. Stability of strike gullies in the mines of the Klerksdorp district. Association of Mine Managers of South Africa, Papers and discussions, 1976-1977.
- MICKEL, R.E. 1935. Pressure Bursts Association of Mine Managers of the Transvaal. Papers and discussions, 1931-1936 : 393-428.
- MULLER, S.C. & Ortlepp, W.D. 1970. Practical support techniques for minimising falls of ground on a deep mine – ERPM Ltd. Association of Mine Managers of South Africa, Papers and discussions, 1970.
- MULLER, F.T., Ortlepp, D. & Herrmann, U.G. 1968. The manufacture of concrete bricks and allied products and their use on the ERPM Ltd. Association of Mine Managers of South Africa, Circular No. 5/68
- MURPHY, S.K. & Brenchley, P.R. 1999. Management of seismicity in a deep gold mine. SARES 99: 2nd Southern African Rock Engineering Symposium, 13-15 September 1999.
- NOBLE, K. 1995. The Introduction of Gully Specific Packs at ERPM. Seminar-Progress with research into rockburst control, stope and gully support, VCR rockmass behaviour, 24 March 1995.
- NOCKLER, E. 1976. Notes on 45 degree gullies on Blyvooruitzicht Gold Mining Company, Limited. Association of Mine Managers of South Africa, Papers and discussions 1976: 55-59.
- ORTLEPP, W.D. & Steele, K. 1973. Rockburst: nature of problem and management counter measures on ERPM. Association of Mine Managers of South Africa, Papers and discussions 1973. Johannesburg.

PRETORIUS, P.G.D. 1958. Some observations on rock pressure at depth on the ERPM Ltd., Association of Mine Managers of South Africa, Papers and discussions 1958 :405-446.

PRETORIUS, P.G.D. 1971. Techniques used to implement the falls-of-ground campaign at Crown Mines Limited and City deep Limited. Association of Mine Managers of South Africa, Papers and discussions, 1971: 343-364.

ROBERTS, M.K.C. & Jager, A.J. 1992. An Analysis of falls of ground and Rockburst fatalities in three mining districts, Rock Engineering Division, COMRO.

ROBERTS, M.K.C. 1995. Stope and Gully support. SIMRAC project, GAP 032. Pretoria: Department of Minerals and Energy.

SALAMON, M.D.G. & Wagner, H. 1979. Role of stabilising pillars in the alleviation of the rock burst hazard in deep mines. Fourth international society for rock mechanics symposium. Montreaux : 561-566.

SIMRAC. 1999. Numerical Modelling of Mine Workings. SIMRAC Project GAP 415. Pretoria: Department of Minerals and Energy.

SMITH, D. & Ortlepp, W.D. 1976. How the problems associated with strike scraper gullies with negative lead were overcome at East Rand Proprietary Mines Limited. Assoc. of Mine Managers of South Africa, Papers and discussions 1976:115-130.

SQUELCH, A.P. & Gurtunca, R.G. 1991. Reduction in Rockfall accidents and Rockburst damage in backfilled stopes. Mine Safety and Health Congress, Johannesburg, Chamber of Mines of South Africa : 229-242

SQUELCH, A.P. & Roberts, M.K.C. 1995. The support of stope gullies.

SQUELCH, A.P., Roberts, M.K.C. & Taggart, P.N. 1995. The development of a rationale for the design of stope and gully support in tabular South African mines. In proceedings of Rock mechanics: models and measurements, challenges from industry. Editors Nelson and Laubach. Balkema, Rotterdam: 919-926.

SPALDING, J. 1949. Deep Mining: An advanced textbook for graduates in mining and for practising mining engineers. Mining publications, Ltd. London.

SPENCER, D. 1999. Progress Report on Simrac Gap 602, 30 October 1999.

SPEARING, A.J.S. 1995. Handbook on Hard- rock Strata Control. SAIMM. Johannesburg. Special publication series SP6.

STARFIELD, A.M. & Cundall, P.A. 1988. Towards a methodology for rock mechanics modelling. Int. J. Rock Mech. Min. Sci. & Geomech. Abstr. 25 (3):99-106.

STEYN, A. 2000. Personal communication concerning gully design in the Free State gold mines. AngloGold rock engineering department.

STEWART, J.M., Gay, N.C. & Gouws, M.J. 1978. Rockfall and Rockurst Problems in South African Mines. Chamber of Mines.

SCHUMANN, E.H.R. & Cook, N.G.W. 1967. The load-compression characteristics of broken ribs. Chamber of Mines Research Report No.23/67.

TALU, M.S., Raby, D.M. & Pothas, W.J.C. 1999. Rock mechanics implications of the safe quality daily blast at Libanon. SARES 99: 2nd Southern African Rock Engineering Symposium, 13-15 September 1999.

TUPHOLME, E R. 1972. Techniques of strata control as applied on Stilfontein Gold Mining Company Limited. Association of Mine Managers of South Africa, Papers and discussions 1972: 335-392.

TURNER P A. 1986. The causes of falls of hangingwall over gullies adjacent to stabilising strike pillars. Chamber of Mines Research Organisation. Research report no. 37/87 project no. gr2p06, February 1986.

TURNER P A. 1987. Causes of falls of hangingwall over gullies adjacent to stabilising strike pillars. Chamber of Mines Research Organisation. Research report no. 37/87 (Amended) project no. gr2p, August 1987.

TURNER P A. 1989. Factors influencing the stability of the lava hangingwall of some trackless mining roadways on the VCR at Western Deep Levels. Chamber of Mines Research Organisation. Internal note no. R03/89, project no. GR6P, November 1989.

TURNER P A. 1990. Some causes of instability of strike gully hangingwalls related to stope layouts at Vaal Reefs gold mine. Chamber of Mines Research Organisation. Internal note R01/90, project number GR5P, January 1990.

VAN ECK D R. An integrated stope support system for the West Rand Region. In Sares 97, 1st Southern African Rock Engineering Symposium: Implementing Rock Engineering Knowledge. Editors R G Gurtunca, T Hagan. September 1997, Johannesburg, South Africa.

VIEIRA, F.M.C.C. 1999. The evaluation of the rock engineering aspects of SMDP mining at great depth and the use of a multiple-attribute utility for mine layout assessment. In Sares 99, 2nd Southern African Rock Engineering Symposium: Implementing Rock Engineering Knowledge. Editor T.Hagan. September 1999, Johannesburg, South Africa.

WATERMEYER, G.A. & Hoffenberg, S.N. 1932. Witwatersrand Mining Practice. Published by the Transvaal Chamber of Mines, Gold Producers Committee.

WAGNER, H. & Tainton, C.J. 1977. An investigation into factors affecting ground conditions in Strike Gullies. Association of Mine Managers of South Africa. Papers and Discussions 1976-1977.

WALTON, A.J. 1929. Driving and resuing methods at Crown Mines. Association of Mine Managers of the Transvaal (Incorporated), 1929.

WHITTEN, D.G.A. & Brooks, J.R.V. 1972. Dictionary of Geology. Great Britain: Penguin Group.

WITWATERSRAND ROCKBURST COMMITTEE, 1924.



APPENDIX 1

APPENDIX 1

Data base of underground observations

The following series of tables provides a summary of the gullies inspected at various mines across the industry.

Gully types indicated are as follows:

- 1 ASG with solid down dip.
- 2 ASG with pillars carried on the gully edge
- 3 ASG with a lagging down dip siding
- 4 ASG with siding separating gully and pillars
- 5 Gully, stope face and siding cut in line
- 6 Footwall lifted gully in a wide heading
- 7 Footwall lifted gully in the panel (overhand configuration).



Gully description						
Mine	Northam	Amandelbult	Amandelbult	Lonhro	Lonhro	Impala
Work place	4L -31	4 -28 W 2E	4 -28 W 3E	Karee 19E 1	Karee 17 E6	17-94N
Reef	UG 2	UG 2	UG 2	Merensky	Merensky	Merensky
Depth	800	67	67	600	658	670
Gully type	2	1	2	2	2	1
dip	20	20	20	11	11	12
No of gullies assessed	2	1	1	4	5	2
Gully size and geometry						
Gully width				1.8	1.8	1.6
Distance of siding behind face	na	na	na	na		
Heading distance	long			2		
Heading width	0			0		
Siding width				1.2	1.2	1.2
Stope width	1.4			2.4	2.5	2.6
Gully height						
Support						
Distance between support across gully		2.5	2.5		3 av, 2.5-3.8	2.2 av
Distance between support along gully		3	3	2	2	2
Type of support on either side of gully	3m pillars	4m pillar and prestressed sticks	4m pillar and prestressed sticks	pillars and mine poles	pillars and mine poles	pillars and sticks + 55cm matpaks
Hangingwall Support	none	1.5 roofbolts	1.5 roofbolts	none	none	1.8 m rebars
Additional special support						addition pillar on updip side
Pattern of installation		3 bolts every 1.5m	3 bolts every 1.5m			
Support quality						
Rock conditions						
Stress fracture intensity	none	none	minor in pillars	minor in pillars	minor in pillars	minor
Stability of hangingwall	stable	triangular unstable wedges	triangular unstable wedges	stable	competent	unstable
Stability of gully sidewalls	stable	stable	stable	stable	stable	stable
Unusual geological conditions	few joints	2 jt sets 1m spac	2 jt sets 1m spac	few joints	few joints	domes
other						
Gully rating						
Overall conditions	good	good	spalling	good	good	moderate
Rating number	1	1	1	1	1	2
Appropriateness of method	yes	yes	yes	yes	yes	yes
Justification						



Gully description	Impala 20-89 18S Merensky	Impala 20-89 18S Merensky	Impala 20-89 1N Merensky	Amandelbult 10-24 3E Merensky	Amandelbult 11L -26 Merensky	Amandelbult 11&12 -32 Merensky
Mine	Impala	Impala	Impala	Amandelbult	Amandelbult	Amandelbult
Work place	20-89 18S	20-89 18S	20-89 1N	10-24 3E	11L -26	11&12 -32
Reef	Merensky	Merensky	Merensky	Merensky	Merensky	Merensky
Depth	810	810	880	550	630	630
Gully type	2	4	4	2	4	4
dip	12	12	12	20	20	20
No of gullies assessed	1	1	1	6	5	3
Gully size and geometry						
Gully width	1.9	1.9	2.5			
Distance of siding behind face		5				
Heading distance	2.5	2.5	2	3		
Heading width		1	1.5		1	1
Siding width			1.2			
Stope width	1.2	1.2	1.2			
Gully height	2.8	2.8	2.8			
Support						
Distance between support across gully	3.1 av	2.5		3	3.5 - 5	3.5 - 5
Distance between support along gully	2	2	2	2.5		
Type of support on either side of gully	pillars and sticks + 55cm matpks	sticks+ 55cm matpks	sticks+ 55cm matpks	pre stressed yielding sticks and pillars		
Hangingwall Support	1.8 m rebars	1.8 m rebars	1.8 m rebars	1.2 rockbolts	1.2 rockbolts	1.2 rockbolts
Additional special support					extra pillars on updip side to control joints	extra pillars on updip side to control joints
Pattern of installation				3 bolts every 2m	4 bolts every 2m	4 bolts every 2m
Support quality				rebars installed at a flat angle	rebars installed at a flat angle	rebars installed at a flat angle
Rock conditions						
Stress fracture intensity	v sever in pillars	fractures in pillar and hangingwall	dense around heading	v definate fracturing in pillars and minor fracturing in hw	severe fracturing along pillars causing movement in hw joints	v severe fracturing along pillars
Stability of hangingwall	stable	moderate	stable	moderate	locally unstable	locally unstable
Stability of gully sidewalls	unstable	unstable	unstable	updip good, downdip unstable	moderate	unstable on downdip side
Unusual geological conditions				some jointing	3 joint sets	dykes
other				some pillars are burst prone	siding was locally ommited to reduce span	pillar bursting causing coltapse of downdip sidewall
Gully rating						
Overall conditions	bad	moderate	moderate	moderate	poor	poor
Rating number	3	2	2	2	3	3
Appropriateness of method	no	no	no	no	no	no
Justification	lack of siding	inadequate width of siding	damage around the heading	sidings required	siding was ineffectively suppted	siding was ineffectively suppted



Gully description	Northam 9 L - 29 1W Pothole Merensky	Northam 9 L 28W 1A Pothole Merensky	Northam 9L 27 Pothole Merensky	Northam 9L-28 W1B Pothole Merensky	Northam 12L 30 1E merensky	Northam 12L 30 1AE merensky
Mine						
Work place						
Reef						
Depth	1800	1800	1800	1800	2000	2000
Gully type	1	3	5	6	3	5
dip	20-25	20-25	20-25	20-25	18	18
No of gullies assessed	1	1	2	2	1	1
Gully size and geometry						
Gully width	1.8	1.8	1.8	1.8		
Distance of siding behind face						4.5
Heading distance			13			5
Heading width			7.5			
Siding width						
Stope width		2	1			
Gully height	2.9				1.5	
Support						
Distance between support across gully	2.25	2.6	1.7-2	1.8	2.5	3
Distance between support along gully	2	2	1.8-2.5	1.75	2.1	2
Type of support on either side of gully	75cm prestressed Apollo packs	75cm prestressed Apollo packs	75cm prestressed Apollo packs	75cm prestressed Apollo packs	75cm prestressed Apollo packs	75cm prestressed Apollo packs
Hangingwall Support	none	none	none	none	none	none
Additional special support						
Pattern of installation		packs too slender, and angle incorrect				
Support quality						
Rock conditions						
Stress fracture intensity	moderate	moderate around ASG heading	dense fractures, but oriented to avoid instability			moderate
Stability of hangingwall	stable		stable	stable stable but joints caused wedge failure in up dip wall	stable moderate. Packs had to be replaced in places	stable
Stability of gully sidewalls	moderate	spalled away	stable			stable
Unusual geological conditions			minor joints	jointing	none	none
other	v limited mining span				Locality poor h/w conditions	
Gully rating						
Overall conditions	good	moderate	good	moderate	moderate	good
Rating number	1	2	1	2	2	1
Appropriateness of method	yes	no	yes	yes	yes	yes
Justification		ASG caused damage to shouldered				



Gully description						
Mine	Northam	Northam	Northam	Beatrix	Bambanani	St Helena
Work place	12L 30 3W	12L 30 2W	12L 30 1W	17B 59E6	84-112S	24 - 30 N1
Reef	merensky	merensky	merensky	Beatrix	basal	basal
Depth	2000	2000	2000	900	2567	1659
Gully type	1	6	5	2	1	3
dip	18	18	18	15	35-40	30
No of gullies assessed	1	1	1	4	3	2
Gully size and geometry						
Gully width				1.4 - 2	1.4 - 1.8	2
Distance of siding behind face				1	2	4
Heading distance			5			2
Heading width						1.75
Siding width				2.5 - 7	1.0 - 1.3	1.2 - 1.4
Stope width						
Gully height						
Support						
Distance between support across gully	2.2	1.7	1.6 - 2	na	2.1 - 3.8	2
Distance between support along gully		2	2	na	1.4	1.7
Type of support on either side of gully	75cm prestressed Apollo packs	75cm prestressed Apollo packs	75cm prestressed Apollo packs	pillars	prestressed 110cm lexus packs on 1.6m spacing	110 cm timber composite packs
Hangingwall Support	none	none	roofbolts	1.8 rockbolts	1.5m splitsets	grouted rebars
Additional special support						
Pattern of installation					staggered 1 bolt per m	2-1-2-1
Support quality					split sets installed at 35 degrees	
Rock conditions						
Stress fracture intensity	moderate to severe	moderate	moderate	minor stress fracturing in pillars	moderate and caused instability	severe and runs diagonally across gully
Stability of hangingwall	moderate	stable	stable	minor instability	unstable	moderate
Stability of gully sidewalls	unstable	stable	stable	stable	unstable	unstable and gully walls are broken back
Unusual geological conditions					0.5m reverse fault + brows	
other					Domes	remnant area
Gully rating						
Overall conditions	poor	good	good	good	poor	moderate
Rating number	3	1	1	1	3	2
Appropriateness of method	no	yes	yes	yes	no	no
Justification	need siding				wide heading would be more appropriate	wide heading would be more appropriate



Gully description					
Mine	Savuka	Savuka	Savuka	Savuka	W Drie
Work place	111.5 L	113 L	104 L updip	104 L	25-16W
Reef	carbon leader	carbon leader	carbon leader	carbon leader	carbon leader
Depth	3145	3190	2920	2920	2055
Gully type	6	5	6	5	5
dip	21	21	21	21	23
No of gullies assessed	3	3	4	1	5
Gully size and geometry					
Gully width	1.85	1.8	1.8	1.8	1.6
Distance of siding behind face				10	
Heading distance				10	
Heading width					
Siding width					1.2
Slope width	1	1	1	1	
Gully height	1.8	2.5 - 2.8	2.3	2.3	
Support					
Distance between support across gully	1.8	1.7 - 2.2	1.4 - 1.9	2.2 - 2.4	1.8
Distance between support along gully	1.8	1.5	1 - 1.3		1.8
Type of support on either side of gully	1.5 X 0.75 packs & backfill	1.5 x 0.75 Packs both sides & backfill	1.5 x 0.75 Packs both sides & backfill	backfill, prestressed elongates & packs	Durapcks
Hangingwall Support	splitsets	splitsets	splitsets	splitsets	
Additional special support	locally ground consolidation		locally sets & void filling	ground consolidation & wire mesh & sets + void filling	
Pattern of installation	3-2 pattern packs are not prestressed and often kicked out	3-2 pattern	2-2 pattern	2-2 pattern	
Support quality		locally the additional sticks are omitted			
Rock conditions					
Stress fracture intensity	severe	severe	severe	severe	severe giving v blocky ground
Stability of hangingwall	locally poor	stable	stable	stable	locally v poor
Stability of gully sidewalls	sidewall scaling due to dense fracturing	moderate	spall back	moderate	v poor, collapse frequently, packs too stiff
Unusual geological conditions	3 joint sets	3 joint sets			dyke
other	v high closure rates		updip mining area in shaft pillar	mined adjacent to abutment with crush pillar on downdip side	Shaft pillar extraction, frequent seismicity
Gully rating					
Overall conditions	moderate	good	good	moderate	poor
Rating number	2	1	1	2	3
Appropriateness of method	no	yes	yes	yes	no
Justification	sidings are too narrow and blasting practice poor			a lot of rehabilitation has been carried out	changes in mining practice and unnecessary stiff packs contribute to poor gully conditions



Gully description					
Mine	Tau Tona	Tau Tona	EGM	Deelkraal	PDWASD
Work place	101 L	93 L E3	88-16 E	33-15 S	93-10 E
Reef	carbon leader	carbon leader	vcr	vcr	vcr
Depth	2905	2525	2600	2900	2600
Gully type	6	6	3	5	6
dip	21	21	20-25	22	20-25
No of gullies assessed	2	2	3	1	2
Gully size and geometry					
Gully width			1.6 - 1.8		1.5
Distance of siding behind face			1		
Heading distance			1	3.5	
Heading width			2	4.2	2
Siding width	3	1.5 - 2		2.3	
Stope width				0.9	
Gully height	2.5	2.5		1.8	
Support					
Distance between support across gully		1	1.6		1.5
Distance between support along gully			1.2 - 1.7	0.9	1.9
Type of support on either side of gully	1.2X1.6 Apollo packs & backfill between packs	backfill & pre stressed elongates + 1.5X0.75 Apollo packs on shoulders	75X1.1 Hercules pack	1.1X.75 prestressed packs	1.1X 1.1m Brutus packs and pre stressed elongates
Hangingwall Support	splitsets	splitsets	1.5 rebars	splitsets	none
Additional special support	resin injection, sets and void filling, & shotcrete				
Pattern of installation	2-1-2-1	2-1-2-1	2-1-2-1	2-2-2-2	
Support quality		splitsets frequently fallen out and not replaced	rebars installed at 45-50 degrees.		
Rock conditions					
Stress fracture intensity	severe stress fracturing perpendicular to gully	severe - 2 sets of fractures in hw - 1 set is steep dipping at 80 degrees, and the second set is flat, approx. bedding parallel.	moderate	moderate	moderate
Stability of hangingwall	stable	stability poor with fall out up to greenbar	stable but deteriorates	moderate	stable
Stability of gully sidewalls	stable	stable	moderate	moderate	moderate
Unusual geological conditions	2 joint sets, + fault	NW-SE joint set	seismic active fault		quartzite beam bet vcr and lava
other	focally poor conditions were faulting crosses gully, or packs are removed to create cubbies				
Gully rating					
Overall conditions	good	poor	good	moderate	good
Rating number	1	3	1	2	1
Appropriateness of method	yes	no	yes	yes	yes
Justification	considerable ongoing rehabilitation work done	gully too close to top of panel, little attempt at rehabilitation			



Gully description						
Mine	Savuka	Savuka	Savuka	Savuka	Savuka	Mponeng
Work place	75 L- 34 W3	75 L- 34 W2	75 L- 34 W1	66- E 1	66- E 1A	94-49 E
Reef	vcr	vcr	vcr	vcr	vcr	vcr
Depth	2300	2300	2300	1998	1998	2800
Gully type	6	6	5	6	3	3
dip	21	21	21	21	21	21
No of gullies assessed	1	1	1	1	1	5
Gully size and geometry						
Gully width	1.8-1.9	1.8-2.5	1.8-2.5		3	1.4-1.8
Distance of siding behind face					4	
Heading distance					2	
Heading width			2		2	1.5
Siding width						
Slope width					3	
Gully height	3-3.5	2.3-2.9	2.3-2.9			
Support						
Distance between support across gully	1.8-1.9	1.8-2.5	1.8-2.5			1.4-1.8
Distance between support along gully	1.6	1.6	1.6	1.5		1.3-1.4
Type of support on either side of gully packs	timber composite packs	timber composite packs	timber composite packs	75X150 Apollo packs and backfill + pre stressed elongates	75X150 Apollo packs and backfill + pre stressed elongates	pre stressed brick composite packs
Hangingwall Support	splitsets	splitsets	splitsets	splitsets	splitsets	splitsets
Additional special support						
Pattern of installation	3-2-3-2	3-2-3-2	3-2-3-2	3-2-3-2	3-2-3-2	2-1-2-1
Support quality						
Rock conditions						
Stress fracture intensity	moderate	moderate	moderate	moderate	moderate	severe
Stability of hangingwall	stable	moderate with some joint bound falls	unstable	stable	moderate	unstable
Stability of gully sidewalls	stable	stable	stable	moderate	moderate	unstable
Unusual geological conditions	3 joint sets	3 joint sets	3 joint sets			dyke and minor fault + steep rolls
other	varying blasting practice resulted in varying sidewall condition and gully depth	vertical drilling to lift footwall	siding cut flat and damages hangingwall		siding cut with flat floor leading to poor pack construction	siding cut with flat floor leading to poor pack construction
Gully rating						
Overall conditions	good	moderate	moderate	good	moderate	poor
Rating number	1	2	2	1	2	3
Appropriateness of method	yes	yes	yes	yes	no	no
Justification		vertical drilling less succesful than horizontal	siding should be cut on reef		siding should be cut on reef	wide heading should be used with siding cut on reef



Gully description		Mponeng	Tau Lekoa	Kloof	Kopanang	Hartebeestefontein	Oryx
Mine		94-52 E	1200 S 4	45-52 stope	44 BW3	17 L	18 C1 South
Work place		94-52 E	1200 S 4	45-52 stope	44 BW3	17 L	18 C1 South
Reef		vcr	vcr	vcr	vaaf reef	vaaf reef	kaikoenkrans
Depth		2800	1100	3380	1200	2320	1850
Gully type		6	2	6	3	3	3
dip		21	25	23	17	9	12
No of gullies assessed		2	3	1	2	3	4
Gully size and geometry							
Gully width		1.4-1.8	1.8-3	1.7	2.4 - 3	1.8	1.9 - 2.1
Distance of siding behind face					2	2.0 - 5.0	
Heading distance			0	0	1	1	1
Heading width						2.4	
Siding width		1.5		1	2		
Stope width			1.7	1.2			1 - 1.2
Gully height			3.2	2.3		2.3	2
Support							
Distance between support across gully		1.4-1.8	1.8-3	1.7	2.4 -3	1.8	1.9 -2.1
Distance between support along gully		1.4	2	1.8	1.3 - 1.4	2.2	
Type of support on either side of gully		pre stressed brick composite packs	prestressed profile props	1.2 x 0.9 m Durapacks 2.4 rebar mesh & lacing	110 brick composite packs only wedged not prestressed	brick composite packs	110 x 75 solid timber packs
Hangingwall Support		splitsets	1.5 rebars		rebar	1.2 split sets	rebars
Additional special support							
Pattern of installation		2-1-2-1	1 bar every 1m along gully	2 - 1 -2 -1	2-1-2-1 or 2-2-2-2 Bricks in packs damaged by blasting	3-3-3-3	2-1-2-1
Support quality							
Rock conditions							
Stress fracture intensity		severe	minor	moderate	moderate	severe, diagonal to gullies	moderate - fractures parallel to gully, suggesting siding was mined out from gully
Stability of hangingwall		stable	stable	stable	moderate locally unstable due to stress fracture orientation	moderate, locally poor	stable some local problems
Stability of gully sidewalls		stable	stable	stable	moderate	moderate, locally poor	moderate
Unusual geological conditions		rolls	2 joint sets		fault, brow		shale band in h/wall
other					Locally no siding cut to support fault	Some evidence that sidings were created well back from face	Gullies very wide
Gully rating							
Overall conditions		good	good	good	moderate	moderate	moderate
Rating number		1	1	1	2	2	2
Appropriateness of method		yes	yes	yes	yes	no	no
Justification					locally siding lagging resulted in adverse fracture patterns. Packs should be prestressed	poor stress fracture orientation possibly due to allowing sidings to lag	siding should be advanced along strike not blasted away from gully.



Gully description	
Mine	Durban Deep
Work place	21 E 24
Reef	kimberly
Depth	900
Gully type	1
dip	80
No of gullies assessed	4
Gully size and geometry	
Gully width	
Distance of siding behind face	
Heading distance	
Heading width	
Siding width	
Stope width	
Gully height	
Support	
Distance between support across gully:	
Distance between support along gully	
Type of support on either side of gully	pillars, yielding elongates rebars where required
Hangingwall Support	
Additional special support	
Pattern of installation	as required
Support quality	
Rock conditions	
Stress fracture intensity	locally moderate stress fracturing due to inedequate width to stoping down dip
Stability of hangingwall	moderate
Stability of gully sidewalls	stable
Unusual geological conditions	faulting, mud seam
other	
Gully rating	
Overall conditions	good
Rating number	1
Appropriateness of method	yes
Justification	