

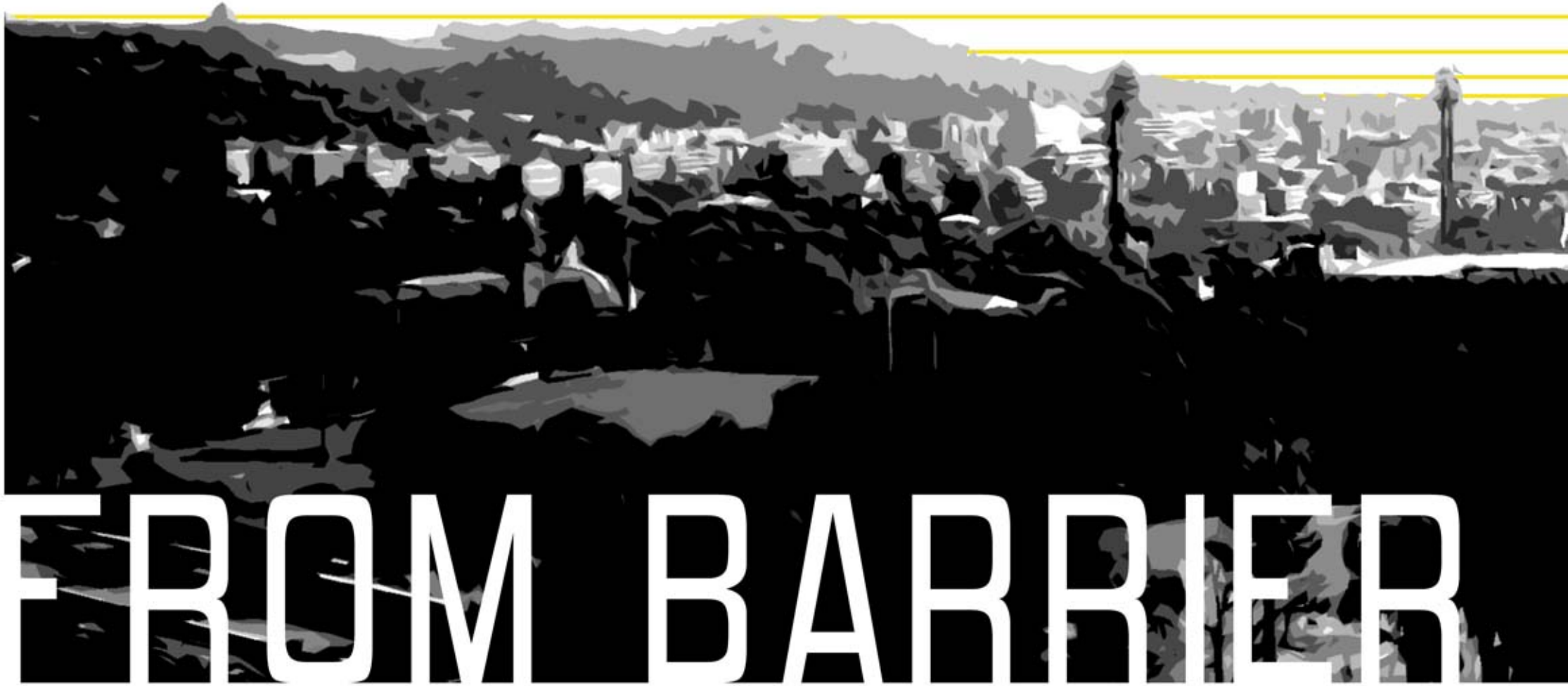

UNIVERSITEIT VAN PRETORIA
UNIVERSITY OF PRETORIA
YUNIBESITHI YA PRETORIA

L O F T U S M E T R O

© University of Pretoria



FROM BARRIER



UNIVERSITEIT VAN PRETORIA
UNIVERSITY OF PRETORIA
YUNIBESITHI YA PRETORIA

R A I L S T A T I O N

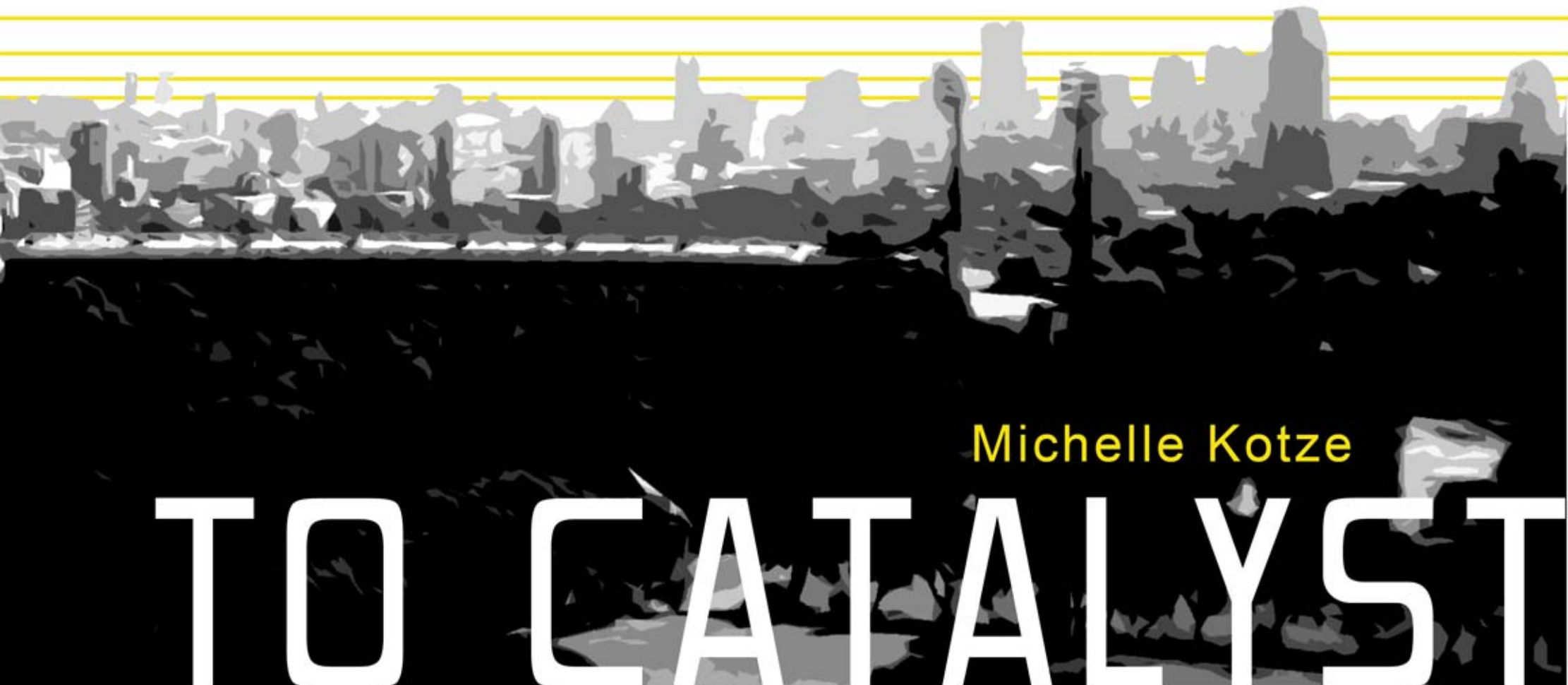

Michelle Kotze

TO CATALYST

Executive summary

South Africa is more than ever, in need of a public transport system integrated within its surroundings. A successful transportation network needs an environment where users can change transport systems with ease and peace of mind. The ultimate goal is to achieve a pedestrian orientated city. This dissertation will attempt to address these problems by redesigning Loftus Metrorail Station located in Hatfield, Pretoria, South Africa.

Within the transport node, Loftus station, the challenge is to combine the different movement systems intersecting at this point, reinforcing connectivity and accessibility. The transition from public to private needs to be clear and legible - this can be achieved through the appropriate design of the building interface, and clearly defining spatial boundaries. The sense of place is lacking in this area, already containing various landmarks associated with Hatfield. These landmarks assist with the legibility of the project area. This orientation device assists with ease of movement and circulation within the area. The defragmentation of facilities in the Loftus precinct area is due to the large scale of the city block. Loftus station becomes a barrier between the University of Pretoria and Loftus Versfeld Stadium. It is an isolated site - dislocated from its surroundings. The lack of facilities has lead to the station becoming underutilized and dilapidated. By dividing the study area into human scaled city blocks, the area becomes manageable. This division reinforces already existing pedestrian movement patterns. The activation of edges and transparency of the structure ensures a secure environment. The different movement systems at this node influenced the design and choice of materials used in the project. The user requirements had to be satisfied. The careful integration of commerce within the station and surroundings ensure not only a transition space, but also a controlled and activated destination place.



MICHELLE KOTZE

23054655

Submitted in fulfilment of part of the requirements for the Degree of Magister in Architecture
(Professional) in the Faculty of Engineering, Built Environment and Information Technology
University of Pretoria
Department of Architecture
2008

Mentor: Gary White
Study leader: Ida Breed

List of Figures

Chapter 1

- 1.1 Image: Smit, B et al., 1971. *Gauteng: The complete map book*. South Africa: Map Studio
- 1.2 Image: www.sarcc.co.za/images/sarcc_logo.gif. [Accessed 24 September 2008]
- 1.3 Image: www.coros.co.za/pictures/logo/metro_rail.jpg. [Accessed 24 September]
- 1.4 Image: www.terrapinn.com/TRes/Organisation/O325559.gif. [Accessed 24 September]
- 1.5 Image: www.tshwane.gov.za/marabastad/images/city_of_tshwane2006lores.jpg [Accessed 24 September]

Chapter 2

- 2.1 Photograph by Tienie van Rooyen [13 August 2008]
- 2.2 Photograph by Tienie van Rooyen [13 August 2008]
- 2.3 Image by Author
- 2.4 Image by Author

Chapter 3

- 3.1 Image by Author
- 3.2 Image by Author
- 3.3 Image: Geography Department. University of Pretoria. [14 February 2008]
- 3.4 Image: Geography Department. University of Pretoria. [14 February 2008]
- 3.5 Image: Geography Department. University of Pretoria. [14 February 2008]
- 3.6 Smit, B et al., 1971. *Gauteng: The complete map book*. South Africa: Map Studio
- 3.7 Image by Author
- 3.8 Photograph: Parking study: University of Pretoria
- 3.9 Photograph by Tienie van Rooyen [13 August 2008]
- 3.10 Photograph by Author [22 April 2008]
- 3.11 Photograph by Author [25 March 2008]
- 3.12 Photograph by Author [22 April 2008]
- 3.13-18 All photographs by Author
- 3.19-26 All photographs by Author
- 3.27 Diagram by Author
- 3.28 Photograph by Tienie van Rooyen [13 August 2008]
- 3.29 Image by Author
- 3.30-42 All photographs by Author
- 3.43 Image by Author
- 3.44 Image by Author

Chapter 4

- 4.1-16 All diagrams by group
- 4.17-20 All images by Author

Chapter 5

- 5.1-5.5 Images: WOODE, D ed. 2003. Mutualpark West Campus. *Architect and Builder*, January/February, p24-33.
- 5.6 Image: DOBSEN, R & LEES, J. 2008. Intuitive process(es) towards responsive urban architecture. *Architecture*, January/February, p24
- 5.7 Image: DOBSEN, R & LEES, J. 2008. Intuitive process(es) towards responsive urban architecture. *Architecture*, January/February, p24
- 5.8-13 Photographs by Bennie Kunz
- 5.14 Image: www.galinsky.com/buildings/waterloo/index.htm [Accessed 10 June 2008]
- 5.15 Image: www.galinsky.com/buildings/waterloo/index.htm [Accessed 10 June 2008]
- 5.16 Image: WILLIAMS, H.A., 1994. End of the line. *Architectural Record*, June 1994, vol. 94, no.6, p90-7
- 5.17 Image: WILLIAMS, H.A., 1994. End of the line. *Architectural Record*, June 1994, vol. 94, no.6, p90-7
- 5.18 Image: <http://www.owl.net.rice.edu/~arch214/waterloo.pdf> [Accessed 10 June 2008]
- 5.19 Image: WILLIAMS, H.A., 1994. End of the line. *Architectural Record*, June 1994, vol. 94, no.6, p90-7
- 5.20 Image: WILLIAMS, H.A., 1994. End of the line. *Architectural Record*, June 1994, vol. 94, no.6, p90-7
- 5.21-25 CERVER, F. 2003. *The world of contemporary architecture*. Germany: Konemann, p722-723
- 5.26-30 CHAPMAN, T. 2007. *Architecture 07. The guide to the RIBA awards*. London: Merryl, p44-47
- 5.31-36 Images by Morne Pienaar, HolmJordaan Architects

Chapter 6

All images by Author

Chapter 7

- 7.1-8 Images by Author
- 7.9 Image: BALLARD BELL, V. 2006. *Materials for Architectural Design*. London: Laurence King, p245
- 7.10 Image: www.smartglass.co.za-performance/data/insulvue/double-glazed [Accessed 22 September]
- 7.11 Image: SHITTICH, C & BIRKHAUSER, U. 2006. *In detail-Building skins*. Germany: Publishers for Architecture, p134-137
- 7.12 Image: www.olderadio.com/archives/stations/LA/P6%20Cone%20&Wrap%20in%20place.JPG [Accessed 15 September 2008]
- 7.13 Image: www.miko-sheeting.co.za/mht/product/range [26 September 2008]
- 7.14 Image: www.spie.org/Images/Graphics/Newsroom/Imported/1047/1047_fig1.jpg [Accessed 29 September 2008]
- 7.15 Image by Author
- 7.16 Image: www1.hunterdouglascontract.com/HDWeb/Cultures/en/Products/SolarControl/SunLouvers/Aerofins/Aerowing/ [Accessed 12 September 2008]
- 7.17 Image by Author
- 7.18-20 Images: www.medienfassade.com/fileadmin/media/pdf/ag4_Mediamesh_Illumesh_en.pdf [Accessed 4 October 2008]
- 7.21 Image by Author
- 7.22 Image by Author

Chapter 8

All images by Author



PAGES

INTRODUCTION 01:00

THEORETICAL APPROACH 02:00

CONTEXT 03:00

URBAN FRAMEWORK 04:00

PRECEDENTS 05:00

DESIGN DEVELOPMENT 06:00

DESIGN CLARIFICATION 07:00

TECHNICAL INVESTIGATION 08:00

LIST OF SOURCES 09:00

APPENDICES 10:00



INTRODUCTION
PLATFORM

↑ Exit

INTRODUCTION

01:00

The real world problem

Problem statement

Hypothesis

Sub problems

Limitations and delimitations

Assumptions



The real world problem:

The world faces many challenges today, one of which is Global Warming. With the earth's natural resources declining, the cost of living is rising and the people who are suffering the most, are in low income sector. Unfortunately with South Africa's previous planning policies, these are the people who are also located on the outskirts of the city. This spatial dislocation of the poor results in long and costly commuting patterns.

"This system generates enormous amounts of movement at great cost and severely aggravates the major developmental issues of poverty, unemployment and inequality facing the society. It results in environments which are desperately inconvenient, particularly for the majority who cannot afford motorized transportation. Under these sprawling conditions society cannot afford to provide a full range of accessible social services. Many people are trapped in space and life is a desperate struggle to meet basic needs."

(Dewar, 1997: 25)

The cost of fossil fuels is sky rocketing and motorists are looking for alternative means of transport. While projects such as the Gautrain are underway and public transport facilities are lacking automobiles will continue to dominate our cities. Since the 1950's, city planners, planned our surroundings from the seat of a vehicle instead of the view of the pedestrian. The problem concludes, that when vehicles are just too costly to own or run - pedestrians will be left with an automobile orientated city. Buildings will appear randomly placed, confused and dehumanized by auto-mobile spaces. Action must be taken to give back the city to those who dwell in it. To use the urban fabric to the maximum - to encourage pedestrian movement in the urban surroundings.

South Africa is longing for adequate public transport facilities. The means by which the vast majority of the population travels to work is via train. Yet railways in South Africa today are dilapidated and act as crime centrals. In interviews with commuters and taxi users, many would rather spend more money using the bus or taxi than to use the Metrorail (the commuter rail corporation). Despite many efforts from the Metrorail management to control the ever growing problem, crime is still one of the major issues that the railway faces today. Another aspect is the lack of existing facilities and the poor design thereof.

All of these aspects limit the optimization of existing resources in the city. This dissertation will attempt to address some of these problems by redesigning Loftus Metrorail Train Station located in Hatfield, Pretoria, South Africa.

Problem Statement

How to integrate the public transport facility, Loftus Metrorail Station, into its surroundings

Tshwane is lacking integration of the public transport systems with the rest of the city. The modal interchanges are problematic, but this is also directly proportional to the lack of pedestrian integration in the city fabric. The roads are bursting out of their seams and the city has insufficient parking facilities to support the infrastructure, as well as insufficient mixed use development to provide diversity on the street for the users comfort.

Hypothesis:

The under utilized rail system is directly related to the inappropriate design of roads in South Africa. A perfect example of this is University road and Loftus Metrorail Station. The Loftus Metrorail Station, Loftus Versfeld Stadium, the University and surrounding institutions all function in isolation. Therefore the train station simply wouldn't achieve its full potential without redesigning its road system and environment, i.e. University Green route and Loftus Precinct.

Sub Problems

- How does one design movement systems for the smooth transition between commuter and the city user? And then disperse them into the surroundings?
- How does one break the barrier that exists between Loftus Stadium and the University of Pretoria?
- How does one design for optimum public safety regarding use of public transport?
- How does one optimally design the link between two nodes i.e. Loftus Metrorail Station, Loftus Versfeld Stadium and the new precinct proposed - to have the necessary public and private areas and well distinguishable boundaries of the above mentioned?

Limitations and Delimitations

- The dissertation will limit itself to the study of integration of different movement systems. Infrastructure and mode transfers will be researched limited to the railway systems in South Africa.
- The project area is limited to Hatfield, between the boundaries of Pretorius Street, Duncan Street, Lynnwood Street and Kirkness Street (fig.1.1).
- Movement analysis and applied systems will be limited to pedestrian behaviour within the defined projects area



fig. 1.1_Road map of the study area

Assumptions

With regards to the near future of South Africa (approximately 15yrs from now):

- An estimate of 46 000 users per day, is projected for the Hatfield Gautrain station
- Loftus Versfeld Stadium will remain a popular sport events arena
- The Gautrain will become a viable transport system for all types of commuters.

Client Profile

01:03

Primary

- Loftus Metrorail Station: Metrorail (SARCC - South African Rail Commuter Corporation)

Secondary

- Green Activity Route: Tshwane Municipality.
- Loftus Precinct: Loftus Management in association with Intersite.

The primary client of Loftus Train Station is Metrorail in joint venture with the Tshwane Municipality. This is perfect timing as the Government and Metrorail are injecting massive investments in the up-grading of the infrastructure.

Metrorail has started with their Turn around Strategy: "The turn around strategy of the National Passenger Rail Company (hereafter referred to as the NPRC) is about repositioning rail over the long term in the heart of public transport."



fig. 1.2_SARCC



fig. 1.3_Metrorail



fig. 1.4_Intersite



fig. 1.5_City of Tshwane



Finance Minister, Trevor Manuel has been allocating more money annually into the upgrading of the commuter rail, reassuring South African commuters that Government is committed to safe, reliant and affordable services which are at World Standard.

Turn around strategy implemented in a three phase plan:

1. Stabilization phase (2007-2010)
 - including upgrades and improvements
2. Recovery phase (2011-2014)
 - including private sector involvement
3. Growth Phase (2015-2030)
 - including 2020 Vision: Passenger rail corridors at the heart of an integrated Mass Rapid transport Network. Alliance with busses and taxi's

Objectives of the NPRC include:

- _ Changes in management
- _ Investing in people
- _ Integrated ticketing system
- _ Reduce fee evasion

Capturing Key strategic corridors such as Tshwane region
Seamless integrated transport system.

According to an article by Donwald Pressly from the Mail and Guardian -Feb 15 2006:

- 2004-2005, R655-million, in capital subsidies
- 2005-2006, R688-million, in capital subsidies
- 2006-2007, just over R1-billion, in capital subsidies.
- 2007-2008, R1,5-billion, in capital subsidies
- 2008-2009, R2-billion, in capital subsidies

(National Passenger Rail Plan : 2006)

The way forward according to the NPRP is to include Intersite (Property arm of SARCC) in more development opportunities connected with the rail to generate resources for the business.

All of the above defends and supports the reasoning behind the proposed new Loftus Metrorail Station in the heart of the developing business core in Pretoria. Loftus Precinct development, which consists of various mixed use areas leading to the entrance of the stadium, and the proposed University Green route, stretching from the proposed Gautrain Station to Magnolia Dell public green area. Parallel to the railway will connect and strengthen the rail station development.



APPROACH
PLATFORM

 Exit

THEORETICAL APPROACH

02:00

Theoretical Premise





Theoretical Premise

In this dissertation, theory in the literal sense is analysed according to the ease of movement for the user. The application of this movement theory will be illustrated and applied in the Urban Framework and Concept Development chapters.

A train station is a node

1. A point of access to trains but also increasingly, to other transportation networks.

At the same time it is a place

2. a diversified collection of buildings and open spaces.
(Bertolini, L: 1998:9)

These two characteristics of a train station are interrelated and seldom function separately. Up until now, Loftus station has been functioning as a transition space in isolation. It lacks that sense of place, the high level of accessibility necessary for development opportunities created by vital masses. In return these developmental opportunities are crucial for the support of the network in transport infrastructure, and the creation of a comfortable public transport system.

02:01



fig. 2.1_The train arriving at Loftus Metrorail Station,
Friday night 20:00,
Game night at Loftus Versfeld Stadium



According to Bertolini: "A node is a point at which subsidiary parts originate or centre (ibid), together with 'lines' or 'channels', nodes are the basic components of a network - the points where the lines are 'knotted', 'inter-connected' or 'interrelated.'" (Bertolini, L: 1998:10)

It is these points and lines of the node that are essential in the operation of the station.

In the Image of the City, Lynch expresses nodes as an important point in space to which the observer travels to and from. A junction or intersection, become places of break in transportation, but more importantly the place where the observers make decisions. "People heighten their attention at such places and perceive nearby elements with more than normal clarity." (Lynch: 1960:72)

Therefore the path and experience of the users need to be effortless and pleasant. Circulation in a node (train station), distinguishing between public and private space and legibility are critical languages the designer needs to articulate in a public building such as Loftus Train Station.

The way in which the user travels through the space is in a line, a directional line from A to B. It is how the designer leads, funnels, collects and disperse' the lines and points throughout the design that determines the success of the place.

02:03



02:04

fig. 2.2_Corner of University road and Lynnwood road
Friday night 20:30,
Game night at Loftus Versfeld Stadium



At Loftus Metrorail Station simultaneous movement systems intersect.
Movement systems applicable at this point are:

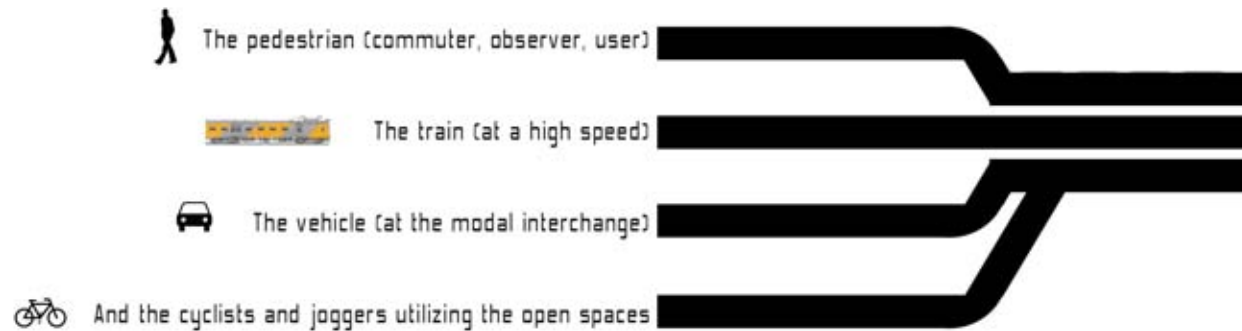

The aim of this conglomerate of systems is to accommodate and ensure the ease of movement within the systems, giving the pedestrian the highest rank within this structure.

The movement system of each mode of movement is different at each means of arrival and departure - the pedestrian, the passenger, the vehicle approaching the modal interchange and the cyclist on the route.

02:05

"One must attempt to see the continuity of space experience in terms of a series of movement systems based on different rates of speed and different modes of movement, each of these interrelated with the other and each contributing its part to the total living experience in the city." (Bacon: 1967:25)

Therefore the moment of transfer from one movement system to the next is important for the ease of movement. This movement through space is the driving organizational force in the station design

Paul Klee's (Bacon:1967:47) theory on movement systems in the dynamics of design, displays how to deal with the first element of design.

"I begin where all pictorial form begins - with the point that sets itself into motion. The point (as agent) moves off and the line comes into being." This is called the first dimension. If the line shifts to form a plane - we obtain a 2 dimensional element: the 2nd dimension. "In the movement from plane to spaces, the clash of planes gives rise to a 3 dimensional body - the 3rd dimension"

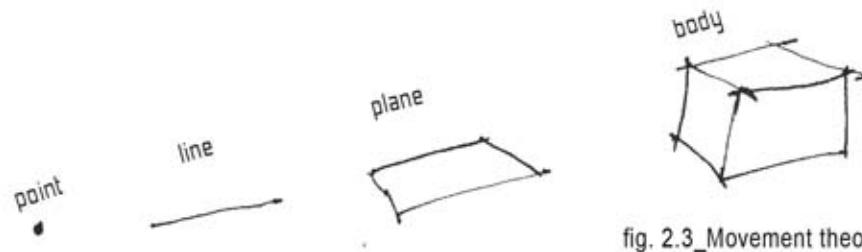

fig. 2.3_Movement theory

"The line now moves and produces the plane - the plane moves and the body comes into being." After this cycle is complete the body then reduces to the starting point and starts its journey afresh, invading the volume of the next dimension (fig. 2.3).

(Bacon: 1967:48)

This movement theory is applied in the design of Loftus Train Station by channelling the movement of people through purposeful routes of movement and strategic points of pause, using focus points within the area to lead the users as well as maintain their attention, influencing the nature of the user's response

The site already contains an important and essential focus point: Loftus Versfeld Stadium.

Upon arrival via train at the station, the first thing passengers see, is this prominent landmark (fig. 2.4), this then naturally gives the passenger direction and orientation and leads the passenger towards it. The interlocking axes becomes the connector between the station and the stadium - creating a system of axis that unifies the whole.

By visually interrelating the station to its surroundings, the vista of the station on platform level (first point of arrival and departure for commuters) is to be open and transparent, creating a sense of approach- and arrival.

When approaching the stadium users can observe all the movement systems (modal interchange, bicycle route, pedestrians in Loftus Precinct) and by making these systems visually open - the space becomes more legible and the user can identify where to go and make quick and easy decisions based on the architecture of the place, passively being aware of the internal movement system of the building within the movement systems of the surroundings.

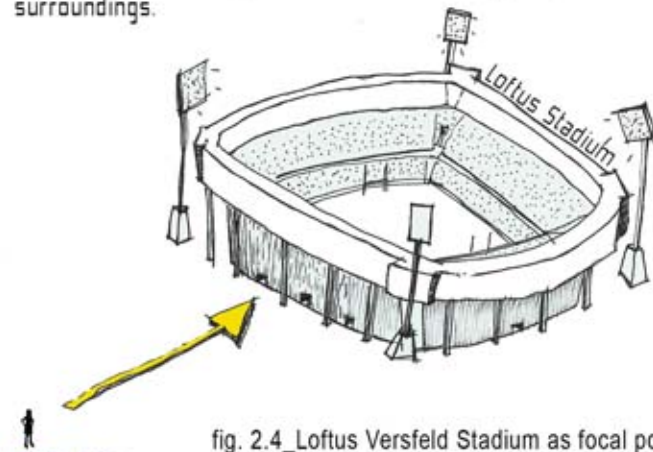

fig. 2.4_Loftus Versfeld Stadium as focal point



CONTEXT
PLATFORM



Exit

CONTEXT

03:00

Project location

Study area analysis

Site analysis

Historical context

Conclusion



03:01



fig. 3.1_Map of Africa, South Africa

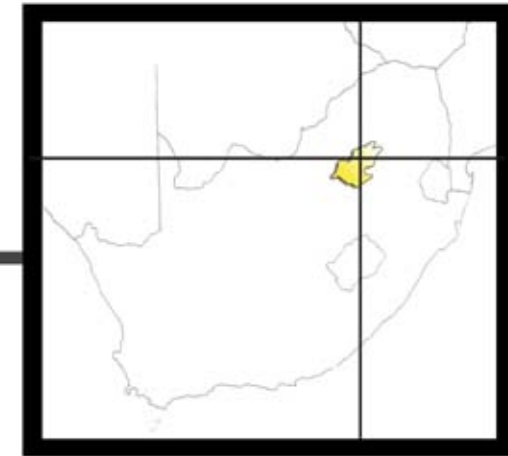

fig. 3.2_Map of South Africa, Gauteng



fig. 3.3_Tshwane, Railway network

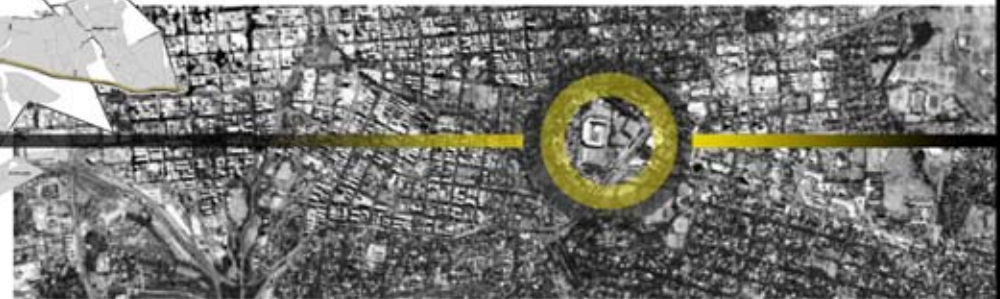

fig. 3.4_Aerial photograph of Pretoria, S 25.750 E 28.167



Project Overview

Study area

The Hatfield area - soon to be home to one of the Gautrain stations - is situated on the crossroad of South Africa, where the N4 highway and the N1 highway connects the North to the South and the East to the West of the country.

The study area of the proposed site stretches to the boundaries of Pretorius Street to the north, Duncan Street to the east, Lynnwood Street to the south and Kirkness Street to the west (fig. 3.6).

03:03

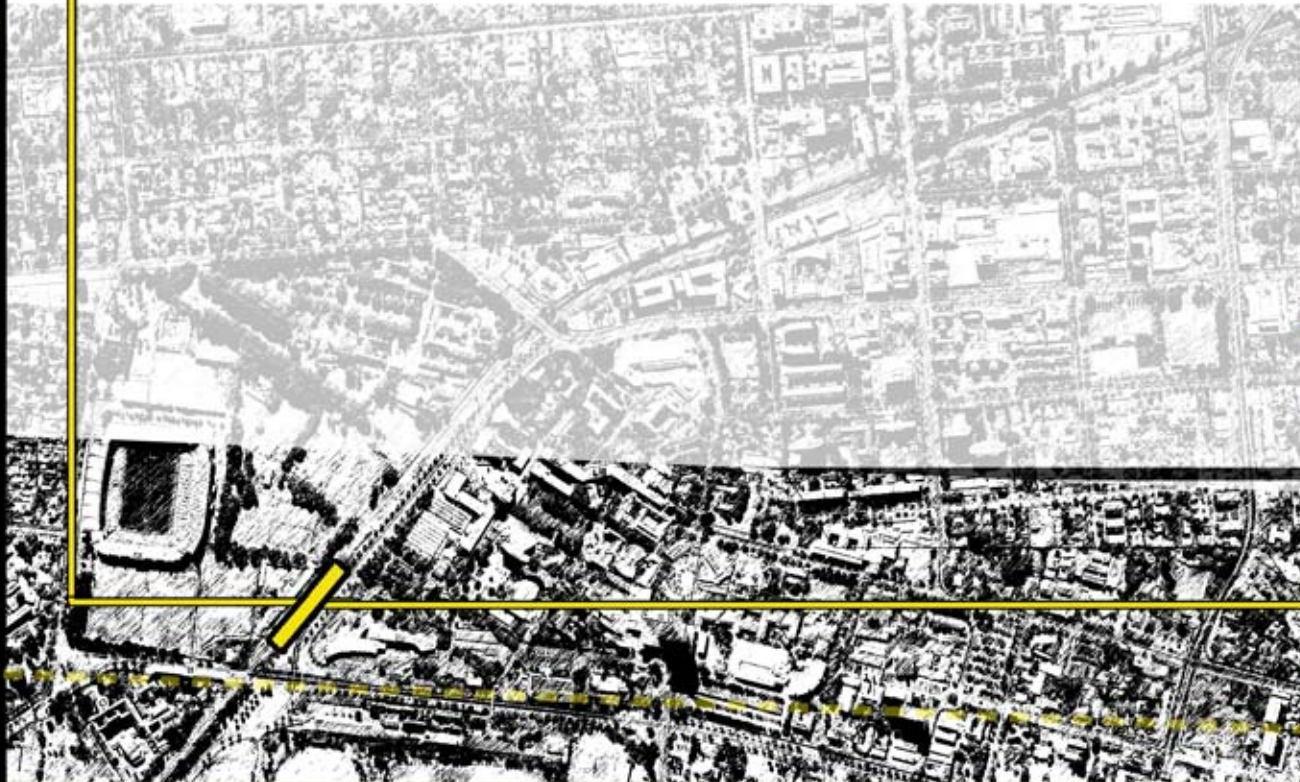

Local Scale

fig. 3.5_Aerial photograph of the University of Pretoria and surrounding area



fig. 3.7_Direction of main routes

Study Area

fig. 3.6_Road map of the study area



03:04

fig. 3.8_Aerial photograph of Loftus Station

The site is at the centre of the rapidly developing Hatfield precinct, covering an area of 3.25 hectares.



Context



Loftus Station



University of Pretoria



Loftus Versfeld Stadium



Girls High School



Municipal Depot

03:05



fig. 3.9



fig. 3.10



fig. 3.11



fig. 3.12



fig. 3.9_Loftus Versfeld Stadium
fig. 3.10_Pretoria Girls High (Heritage)
fig. 3.11_Administration building (UP)
fig. 3.12_Municipal depot



Public & Private

- public
- private
- proposed site

03:06

- 1 Loftus Versfeld
- 2 Mixed-use
- 3 Restaurant
- 4 University of Pretoria

There are very little public facilities within the study area. These facilities are mono functional and are restricted to time constraints. Such as Loftus Versfeld stadium - only occupied during match times on weekends. It is apparent that the study area lacks diversity.



Building Heights

- one level
- two levels
- three levels
- four - six levels
- seven - ten levels
- eleven - fifteen levels

Open Areas

- ① Girls High - Sport Fields
- ② Loftus Rugby Fields
- ③ Loftus additional parking
- ④ University Staff Parking
- ⑤ University Green Space



The street perimeter lacks continuity that building heights and placements offer. There are too many under utilized open spaces inaccessible to the public. These open spaces need to be defined by the placement of walls, landscaping or buildings (4-6 levels). Ground floor edge treatment to relate to a pedestrian scale through facade design.

03:07



03:08

- ① Girls High-Sport Fields
- ② Loftus Rugby Fields
- ③ Loftus Additional Parking
- ④ University Staff Parking
- ⑤ University Green Space



fig 3.13 - 3.18_Contextual photographs



Links to the site

Most Direct:



Least Direct



03:09

- A ★ ★
- B ★
- C ★ ★ ★
- D ★ ★ ★
- E ★
- F ★ ★ ★ ★ ★ ★
- G ★ ★ ★ ★ ★ ★
- H ★





A

Main vehicle and pedestrian link to the south, and ultimately Johannesburg. Existing pedestrian route between Hatfield and Brooklyn.

B

Important vehicular and pedestrian link to the site. Linking the east (Menlyn) to the site and ultimately Johannesburg.

Note: Most commuters currently use this road to the Brooklyn area

C

Important vehicular and pedestrian link to the site. Linking the east (Menlyn) to the site and ultimately Johannesburg.

Most commuters currently use this road to the Brooklyn area

F

Currently a visual link with Loftus Versfeld Stadium, with great potential of becoming a physical link.

03:10



E

Currently this is a link via Metrorail towards Hatfield but in future this will become a link to the Gautrain station. Therefore this is an important link to the rest of South Africa. Embracing this link in future for pedestrians presents itself as an opportunity



G

Once a physical link to Loftus Versfeld Stadium - now a visual link only due to fenced off community.



H

Direct link to the University of Pretoria. By facilitating students with cost effective travelling, the commuter rail will gain strength and diversity.



D

Locally, linking the Hatfield CBD to the site.

Major vehicular link leading to the N1 highway - thus the rest of South Africa.

fig. 3.19 - 3.26_Contextual photographs



Paths

According to Lynch:
"channels along which the observer
customarily, occasionally or potentially
moves."
(Lynch, 1960:47)

03:11

Main Pedestrian route



Main Vehicular route







The path of the user is determined by the layout of the city grid. Pedestrians are forced to walk around large city blocks - no through fare exists. Vehicles dominate roads, sidewalks are inadequate and the walking distance radius is large.



Nodes

According to Lynch:
"strategic spots in a city into which an
observer can enter, and which are
intensive foci to and from which he is travelling."
(Lynch, 1960:47)

-  Loftus Metrorail Station
-  Loftus Versfeld Stadium
-  University of Pretoria
-  Hatfield Core
-  Magnolia Dall Urban Park

03:12



Existing nodes are dependant on each other, yet these nodes are not physically linked.



Landmarks

According to Lynch:
"Landmarks are another type of point-reference, but in this case the observer does not enter within them, they are external."
(Lynch, 1960:48)

03:13

- Pretoria
- ① Loftus Versfeld Stadium
- ② Pretoria Girls High (Heritage)
- University of Pretoria
- Ⓐ Administration building
- Ⓑ Engineering Tower
- Ⓒ Du Merensky Library (Heritage)
- Ⓓ Aula Theatre
- Ⓔ Du Lettere building (Heritage)

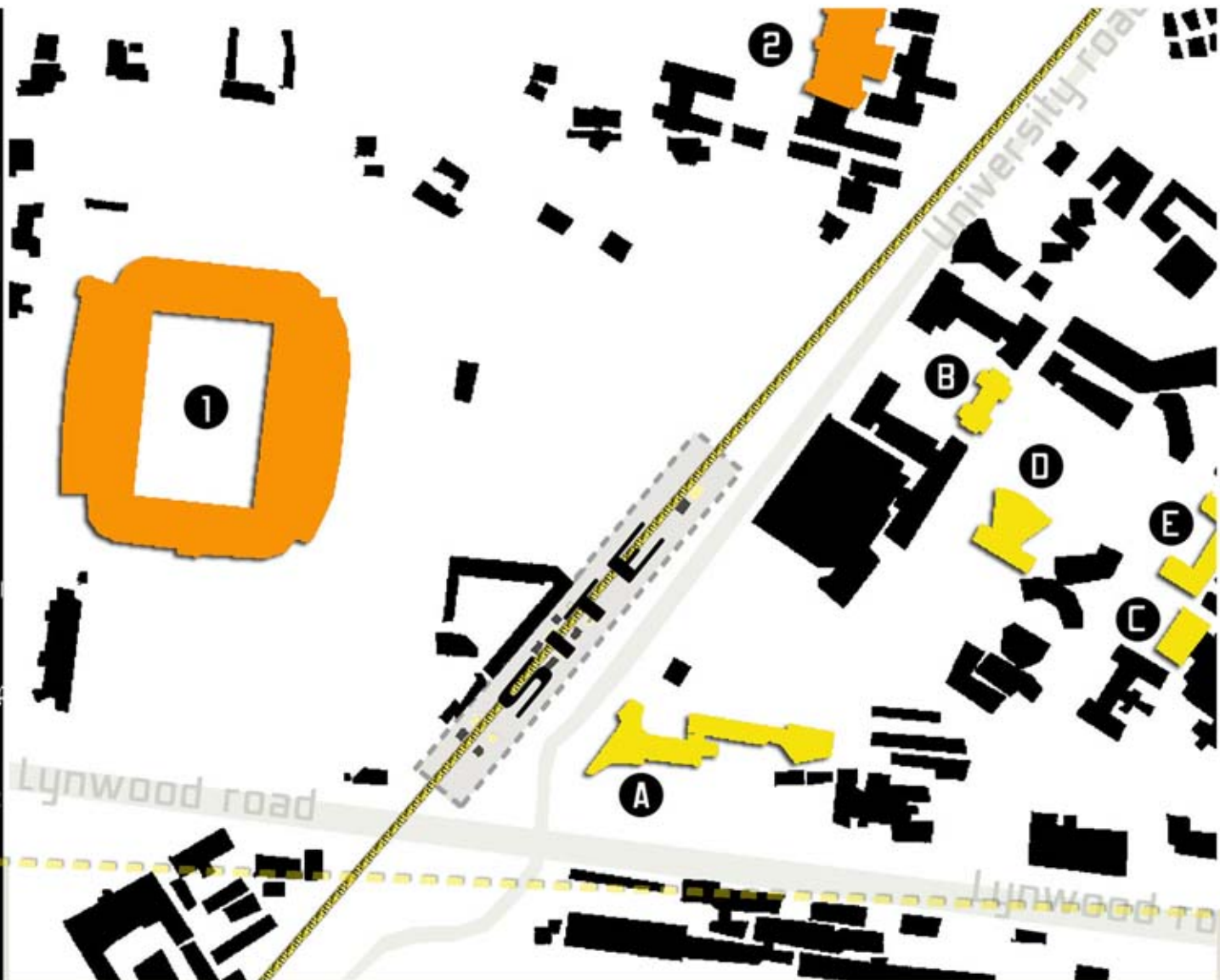

The study area contains many significant landmarks symbolic of Hatfield area. These landmarks are visible throughout the area and act as points of reference. The accessibility of these landmarks are an issue and need attention.



Edges

According to Lynch -
edges are the linear elements not used
or considered as paths by the observer.
(Lynch, 1960:47)

Well defined edge



Poor edge condition



03:14

Buildings are set back too far from the street. No continuous edge exists, resulting in a poor street interface and passive surveillance.



Study area conclusion

From the analysis of the project area, one can clearly see that one of the main problems with the site is the large scale of the city block. The city block is too large and results in inadequate pedestrian movement around a vacant area which is inaccessible and detrimental to the proposed train station. Therefore the proposed site will be divided into typical size city blocks (fig. 3.27) with defined edges, activating and reinforcing existing pedestrian routes in the area.



fig. 3.27_Diagram illustrating proposed division of city grid

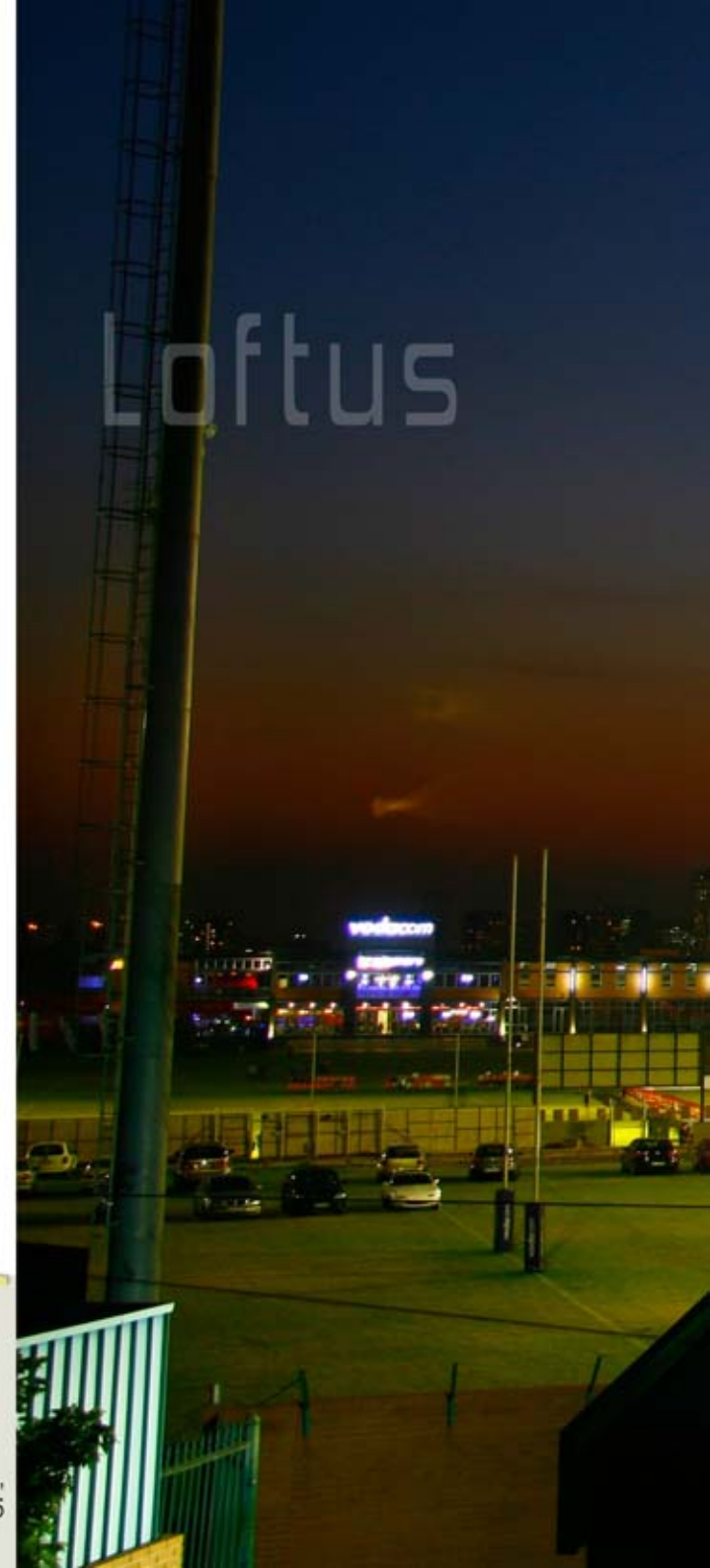

fig. 3.28_Loftus Versfeld Stadium,
Game night, 20:05

Versfeld Stadium



03:16

Site Analysis

Currently Loftus Metrorail Station consists only of a platform, with a length of 250m, and under utilized staircases leading to various neighbouring facilities such as Loftus Versfeld Stadium, Pretoria Girls High School and the municipal depot (fig. 3.38).

All of these facilities are fenced off for safety reasons.

Thus, there is no direct route to the surrounding areas and the only entrance to the station is from University road. The entrance consists of a tunnel underneath the train tracks that terminates with staircases onto the respective platforms (fig. 3.28).

There are no ticket, control or security offices at this point (fig. 3.33). The provided synthetic lighting is out of order and the ablutions are vandalized and not fit for use (fig. 3.40).

This creates an unsafe and hostile environment.

fig. 3.31_View of Loftus Stadium



fig. 3.30_Signage on site, vandalised



fig. 3.32_Shelter on platform

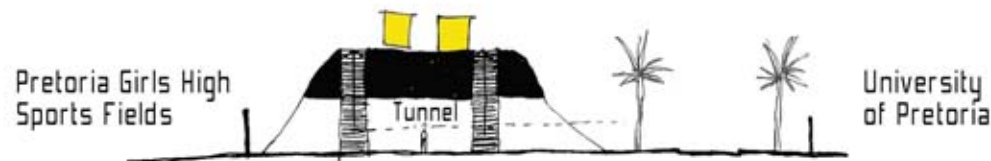

fig. 3.29_Illustration of tunnel and staircases



fig. 3.33_Exits not in use

fig. 3.34_Current entrance from University road





fig. 3.43_Current Station plan

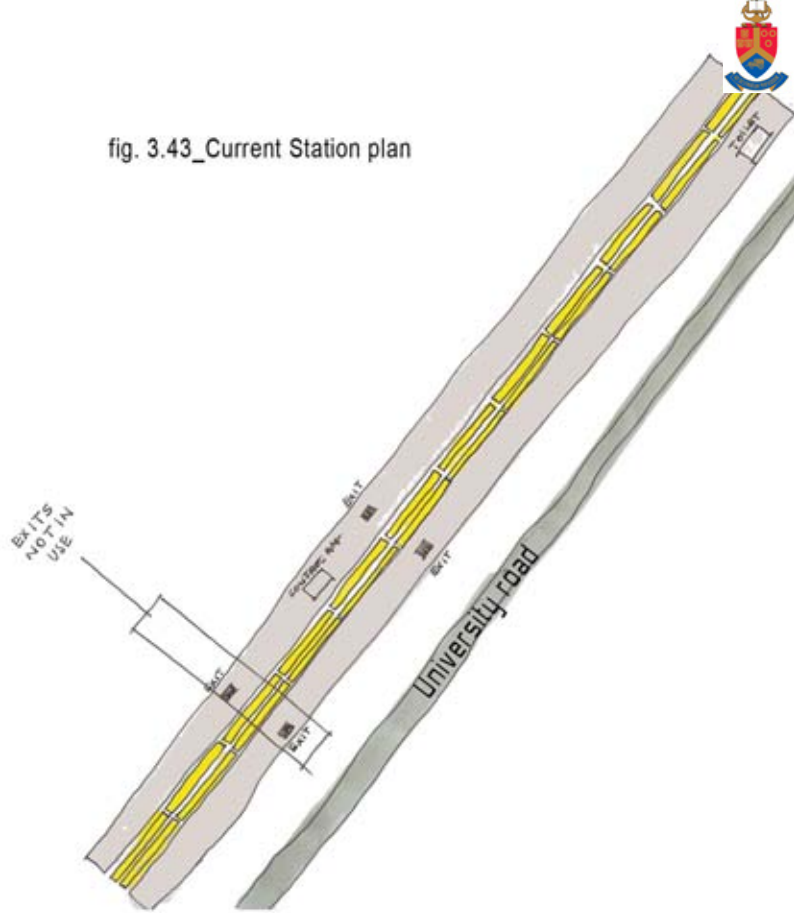

fig. 3.44_Current Station exit plan

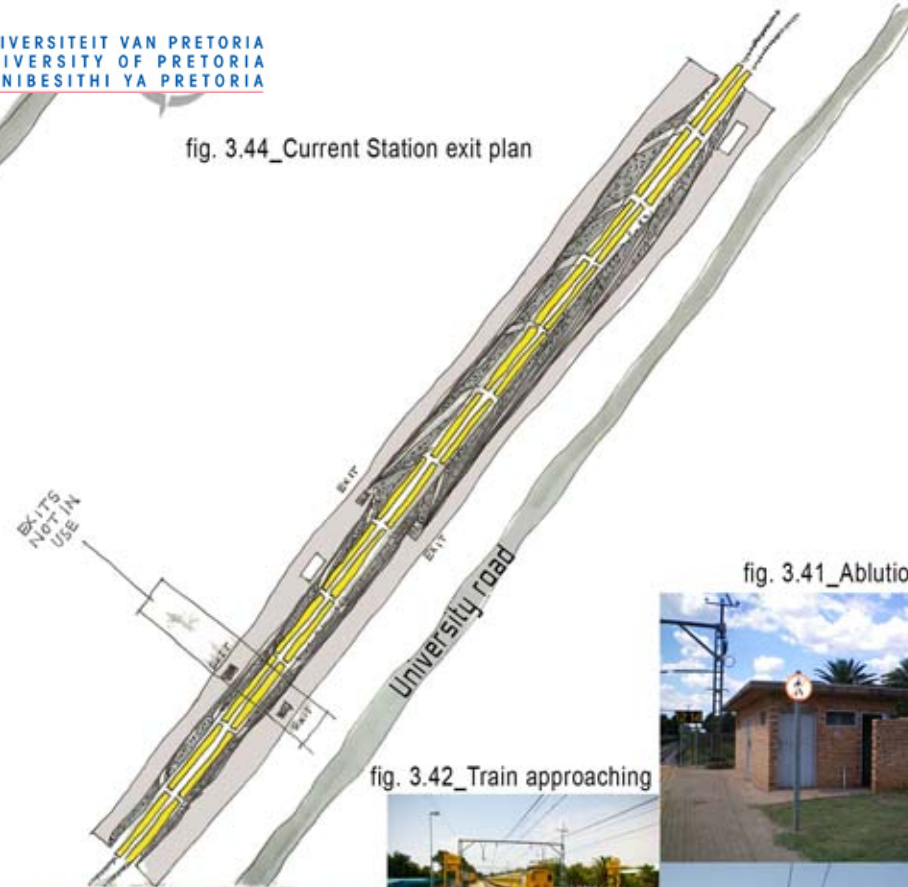

fig. 3.41_Ablution facilities



fig. 3.42_Train approaching



fig. 3.35_Pedestrian pass under railway



fig. 3.36_ Stairway to platform



fig. 3.37_ Stairway from platform



fig. 3.38_ Stairway not in use

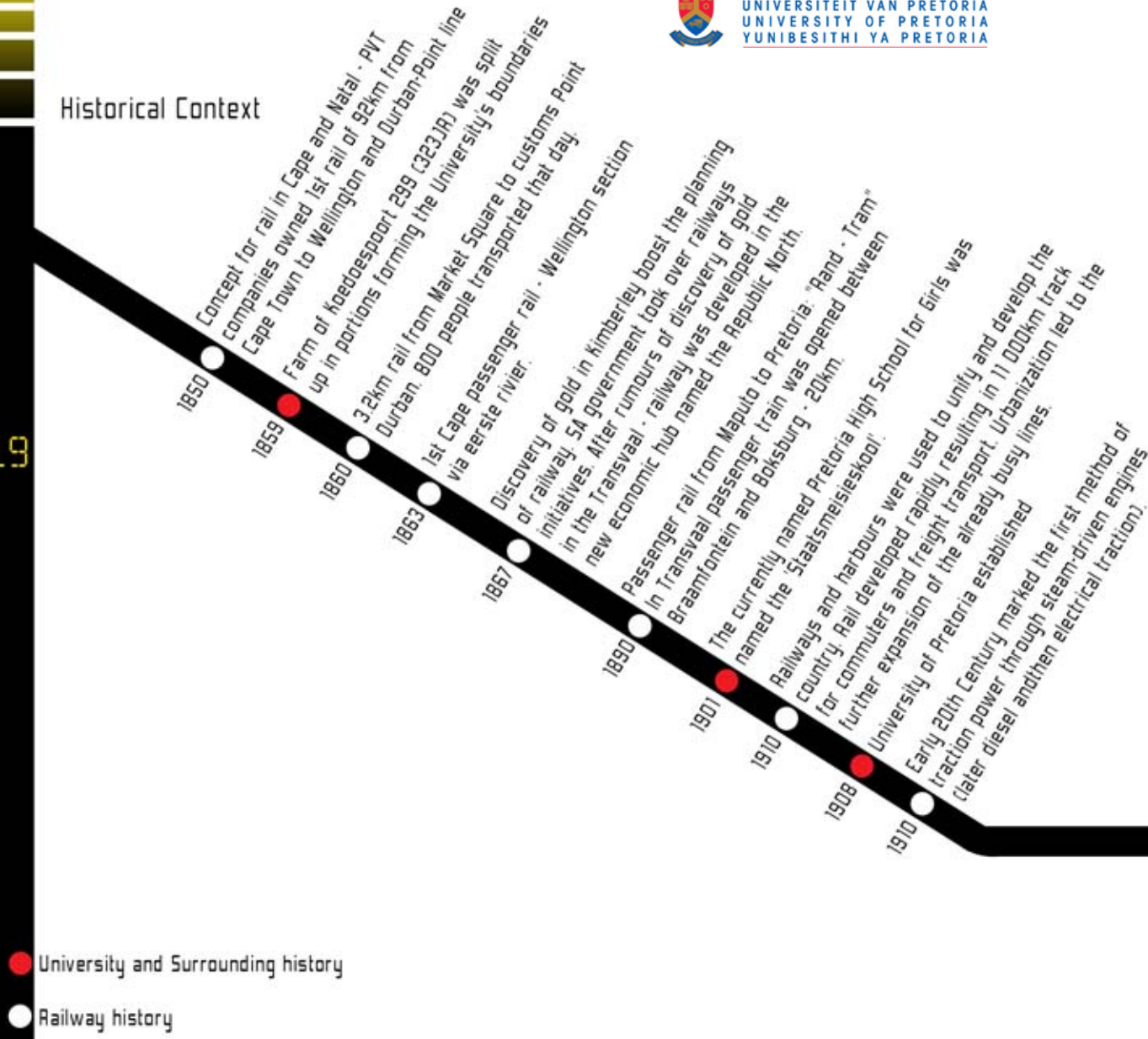

fig. 3.39_ Stairway to Loftus not in use



fig. 3.40_ Platform embankment, vandalized litter bin

Historical Context



1910 ● The new railway was constructed next to university along University road.

1923 ● The first concrete stadiums structure was built at the site by the City Council and had a capacity of 2000 people. Named after Mr. Robert Owen Loftus Versfeld.

1930's ● No more "fast" engines pulling coach like a horse cart. The new technology allowed for the "rail car" to be engineered exclusively on "branch lines".

1937 ● Electrical traction introduced in the Rand. The advantage of electrical integration provides lighting in the coaches.

● University and Surrounding history

● Railway history

1960's ● Around this time the station was constructed on the current site.

1970 ● Urbanization out of control. Railways overloaded. Pressure resulted in SARTH changing to South African Transport Services (SATS) in 1981.

1978 ● SATS transported nearly 500 million commuters, but due to political problems in the 80's and 90's, the market share for rail declined.

1989 ● SATS transferred its functions to a newly formed company called Transnet, with various main businesses such as Spoornet, Portnet and SAA.

1990 ● Transnet shedded its commuter services to the South African Commuter Corporation (SARCC). The SARCC inherited land and properties in and around stations and corridors for the purpose of commercialising these areas for financially contributing to a reduction in subsidisation of the social commuter rail service.

1992 ● A wholly-owned subsidiary company of the SARCC, Intersite Property Management Services (IPMS) was formed to perform this function for the corporation.

2004 ● Transport Minister Jeff Radebe announced that the SARCC is to lead and drive the consolidation of passenger rail entities to form a single passenger rail entity. Consolidation of Metrorail in 2006 will be the first phase:

Today ● Due to the lack of investment in rail infrastructure and shortage in management and technical skills the rail is facing challenges. Limited coverage also meant the loss in market share.

2010 ● The Loftus stadium is currently being upgraded to Soccer World Cup standards with 51,762 seats.



2. The specific urban fabric is too large a scale, limiting pedestrian movement.

The gated community of the University is another issue. Pedestrians are forced to walk around the block. This cuts off the Hatfield Business Core from the South of the precinct. The same goes for the Loftus Stadium Urban block which is according to many urban principals simply too large to function correctly with the urban fabric.

Drawbacks

- The University grounds, Loftus Versfeld and Pretoria High School for Girls create a pedestrian barrier due to its palisade fence enclosing the grounds.
- Above mentioned institutions will not easily remove these fences due to its security importance.
- The lack of pedestrian arcades through the large city block

Opportunities

- To provide security to the above mentioned institutions through means of other architecturally designed elements, other than a mere palisade fence.
- The creation of secured pedestrian arcades through these city blocks

3. The area needs to be sensitive to the lowest common denominator: the pedestrian

Drawbacks

- The lack of accommodating other transport/movement systems
- Current physical context does not cater for pedestrians

Opportunities

- Creating tree planted boulevards with sidewalks for pedestrians
- Calming traffic by means of focussing on pedestrian design
- Softening the urbanity through pedestrian scaled design
- Influx of pedestrian movement to the area feeding the Metrorail Station and its accommodating functions.



FRAMEWORK
PLATFORM

↑ Exit

URBAN FRAMEWORK

04:00

- Group framework
- Urban criteria analysis
 - Opportunities
 - Key interventions
- District establishment
 - Streetscapes



Group Framework

The following framework was done as a group effort

Throughout this chapter, the application of the movement theory is reputed and supported by analysis of the surroundings and strategic placement of key interventions.

Framework proposal:

"FOR THE PEOPLE"

Vision Statement

Integrating the University and Hatfield CBD precincts into one functioning network of innovation and social cohesion, amongst public, private and academic sectors. The transformation is a twofold interdependent proposal with the single vision as driving force:

UNI-R-CITY

Unified Research City

S.T.A.R.T

Social Transition through Activating Regeneration Techniques

Establishing the Hatfield precinct as a multi-dimensional node. A place of continual social, cultural and civic regeneration. A place that defines itself as vibrant and multi-functional. Hatfield's continual transformation will be driven by the creation of interdependent mixed-use nodes - including transport, mixed use, culture, commerce and political, allowing a dynamic interface for social expression.

Hatfield must become a place for the people; a place for all ethnic and social groups.

KEY INDICATORS:

- _ VITALITY
- _ ACCESSIBILITY
- _ DIVERSITY
- _ EQUITY
- _ CONTROL

A. Performance Criteria:

(CABE, 2006:5)

According to CABE in the United Kingdom - successful cities all around the world all have the same qualities in common. Some of these qualities have been analysed according to the study area within the University and Loftus city block and have been graded as Good, Average and Poor. In the respective performance criteria each block was surveyed and analysed to ultimately give the respective block an overall rating. (See appendix A)



A. Performance Criteria consisting of 7 categories:

1. Character: Sense of place and history

A place that responds to and reinforces locally distinctive patterns of development and landscape:

- _ Distinctive landscapes
- _ Natural features
- _ Locally distinctive buildings
- _ Streets and street patterns
- _ Special spaces
- _ Skylines and roofscapes
- _ Building materials
- _ Local culture and traditions
- _ Avoiding standard solutions



fig. 4.1

2. Continuity and enclosure: Clarity of form

A place where public and private space are clearly distinguished

- Enclosing streets and other spaces by buildings and trees of a scale that feels comfortable
- Streets, footpaths and open spaces overlooked by buildings
- No leftover spaces unused and uncared for
- Avoiding gaps in the line of buildings

fig. 4.2



3. Quality of the public realm: Sense of wellbeing and amenity

A place with public spaces and routes that is lively and pleasant to use

- Suited to the needs of everyone, including disabled and elderly people
- A feeling of safety and security
- Uncluttered and easily maintained
- Carefully detailed with integrated public art
- Well-designed lighting and street furniture
- Attractive and robust planting



fig. 4.3

4. Ease of movement: Connectivity and permeability

A place that is easy to get to and move through

- Roads, footpaths and public spaces connected into well-used routes
- Density highest where access to public transport is best
- Direct routes that lead to where people want to go
- A choice of safe, high quality routes
- Easy accessibility

fig. 4.4



5. Adaptability: Ease of change

A place that can change easily

- Buildings and areas adaptable to a variety of present and future uses
- Possibilities for gradual change
- Flexible uses

fig. 4.5



6. Legibility: Ease of understanding

A place that has a clear image and is easy to understand

- Landmarks and focal points
- Clear and easily navigable routes
- Gateways to particular areas
- Works of art and craft
- Signage and waymarkers
- Lighting
- Views

fig. 4.6

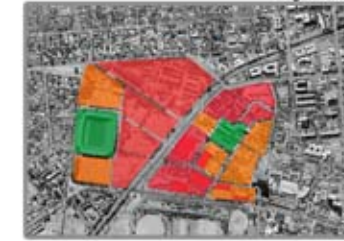

7. Diversity: Ease of choice

A place with variety and mixed uses

- A mix of compatible uses and tenures
- Variety of layout and building form
- Diverse communities and cultures
- Variety of architectural styles
- Biodiversity

fig. 4.7





B. Performance criteria according to the Built Environment

The form of development is the physical expression of urban design. It consists of the relationships, shape and size of buildings, structures and spaces. It will influence the user's activity and movement in a place and so is fundamental to the success of a place. The most important elements of development form are listed here. Each of these elements are informed by the eight urban design qualities described to create the physical components of a plan. (Commission of Architecture and the Built Environment)

1 Urban structure: The essential diagram of a place showing:

- The relationship between new development and nature, land form and existing buildings
- The framework of routes and spaces that connect locally and more widely, and the way developments, routes, open spaces and precincts relate to one another

fig. 4.8



2 Urban grain: The nature and extent of the subdivision of the area into smaller development parcels showing:

- The pattern and scale of streets, blocks and plots
- The rhythm of building frontages along the street as a reflection of the plot subdivision



fig. 4.9



3 Density and mix: The amount of development and the range of uses this influences, to include:

- The intensity of activity relative



fig. 4.10

4 Height and massing

The scale of a building in relation to:

- The arrangement, volume and shape of a building or group of buildings in relation to other buildings and spaces
- The size of parts of a building and its details, particularly in relation to the size of a person



fig. 4.11

5. Building type

- The size of the building footprint its storey heights and means and location of access
- The relationship of the building to adjacent buildings and how it relates to external space at ground floor level
- The nature and extent of the building's setback at upper floors and roof treatment



fig. 4.12

6 Facade and interface

The relationship of the building to the street:

- _ The rhythm, pattern and harmony of its openings relative to its enclosure
- _ The nature of the setback, boundary treatment and its frontage condition at street level
- _ The architectural expression of its entrances, corners, roofscape and projection



fig. 4.13

8 Streetscape and landscape

The design of route and spaces, their microclimate, ecology and biodiversity to include:

- _ Paving, planting and street furniture
- _ The integration of public art, lighting, signing and waymarkers
- _ The treatment of parks, play areas, natural features and recreation areas
- _ Consideration of long term management and maintenance issues



fig. 4.15

7. Details and materials

The appearance of the building in relation to:

- _ The art, craftsmanship, building techniques and detail of the various building components true to local context
- _ The texture, colour, pattern, durability and treatment of its materials
- _ Materials sourced from local and/or sustainable sources, including recycled materials where possible
- _ The lighting, signage and treatment of shopfronts, entrances and building security



fig. 4.14

Average rating of each block:

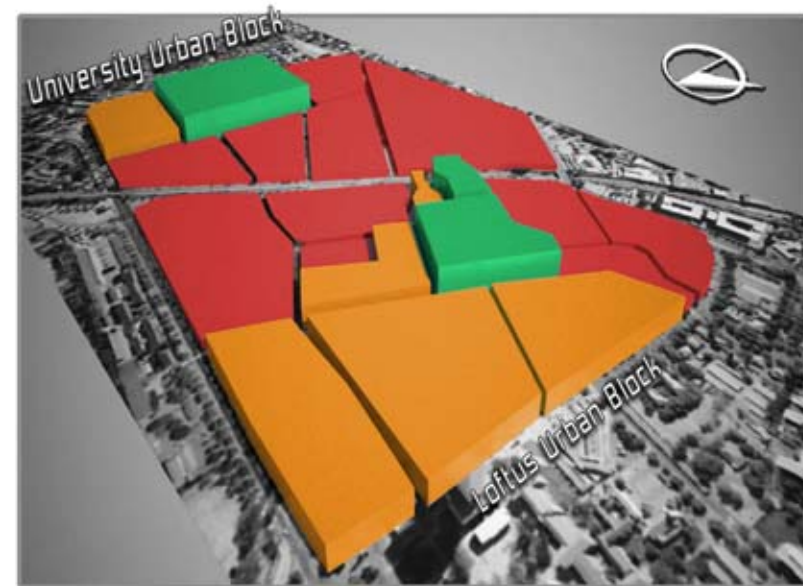

fig. 4.16



Conclusion:

Subsequently it is clear from the 20 blocks analysed, 11 of these blocks are below standard (fig. 4.16). Most of which are concentrated around the project area under investigation. This is due to the lack of continuous street edges, mixed uses and permeability.



Opportunities

- Gateway/Landmark
- Visual Arts Extension
- Education Development
- Botany Extension
- Residential & Mixed-use
- Research & Mixed-use
- Commerce & Mixed-use
- Modal Interchange
- Refurbishment

04:05



The opportunity for a modal interchange linking to Loftus Versfeld Stadium via a new mixed development within the new city grid.

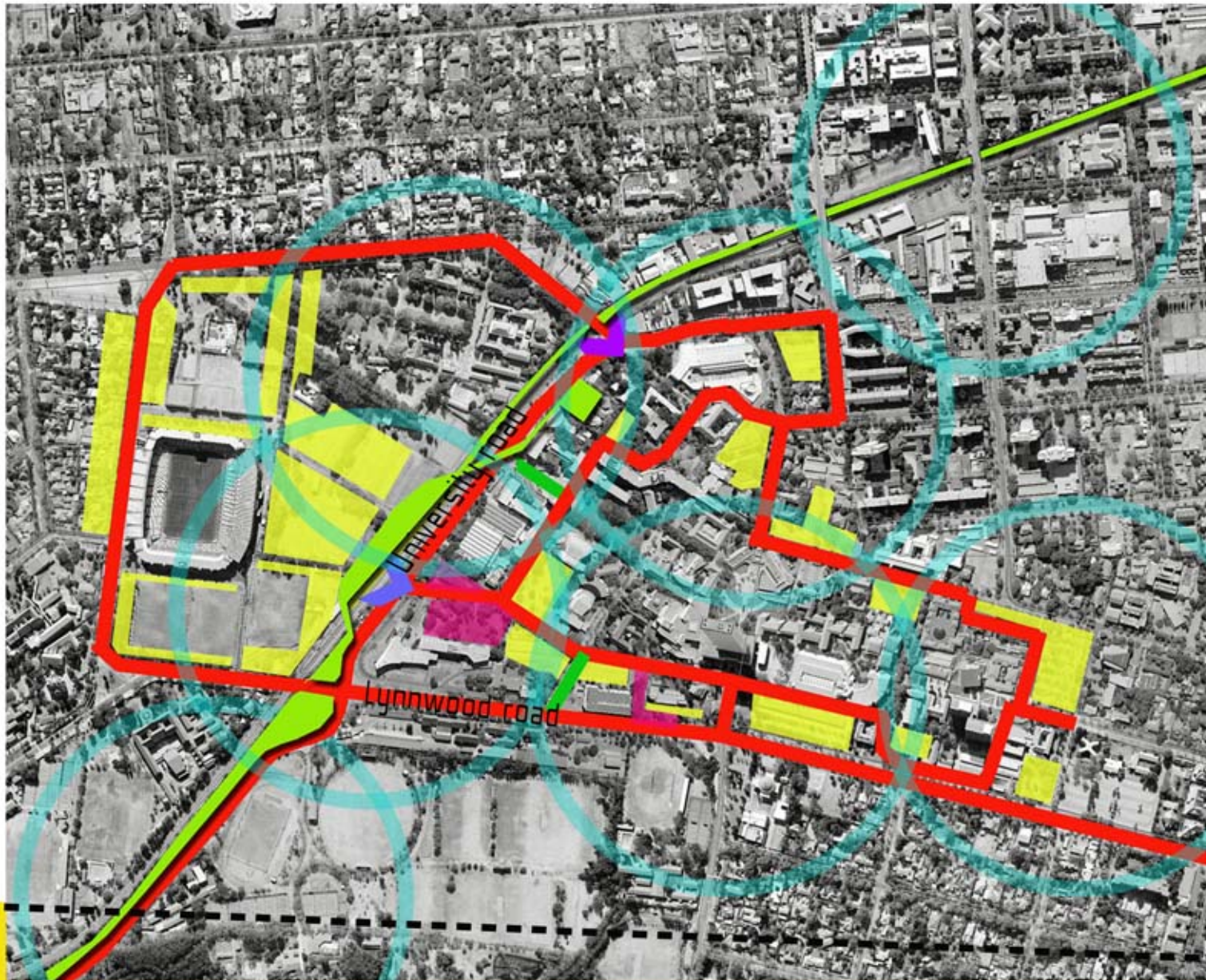

Key Interventions

-  Pedestrian only routes
-  New vehicle & pedestrian entrance
-  New pedestrian entrance
-  400m walking circles
-  New improved green threshold areas
-  Improved pedestrian & vehicle routes
-  Densification
-  New public green route linked between Gautrain Station & Magnolia Dall Park

04:06



The establishment of the Green activity route stretching from Magnolia Dell urban park to the new Gautrain Station. Reinforcing the existing movement routes of pedestrians



Urban design proposal:

"...the relationship between different buildings; the relationship between buildings and streets, squares, parks and waterways and other spaces which make up the public domain; the nature and quality of the public domain itself; the relationship of one part of a village, town or city, with other parts; and the patterns of movements and activity which are thereby established: in short, the complex relationships between all the elements of built and unbuilt space"
(Department of the Environment: 1997)

Initial key interventions comprise the implementation of various urban design strategies and protocols. The guiding objectives behind these principles are as set out in the "Vision Statement" for the areas proposed future development strategy.
The interventions at the urban level include the implementation of pedestrian network development guidelines, proposal and guidelines for densification and development as well as the reuse of underutilized threshold green spaces.

District identification and densification:

The specific Study area is riddled with low density low efficiency land use in the form of parking areas and unused threshold green spaces. These areas have been identified as areas that are underutilized and have good development potential without impacting on the community environment that is being developed on campus and surroundings.

Proposed district establishments:

The improvement of integration in terms of access and connection to enhance sport, scientific and academic collaboration and interaction is the key driver to a successful precinct development. The new precincts will serve to develop and sustain a community where interaction and inter-disciplinary processes with the community is implied. The new precincts located in close proximity to one another in the framework is to encourage design that facilitates interaction between these diverse fields of study, opening up new avenues of study and collaboration, streamlining these interdependent processes by, cross pollination and allowing for resource, facility allocation and sharing.

The identified precincts in the study area include:



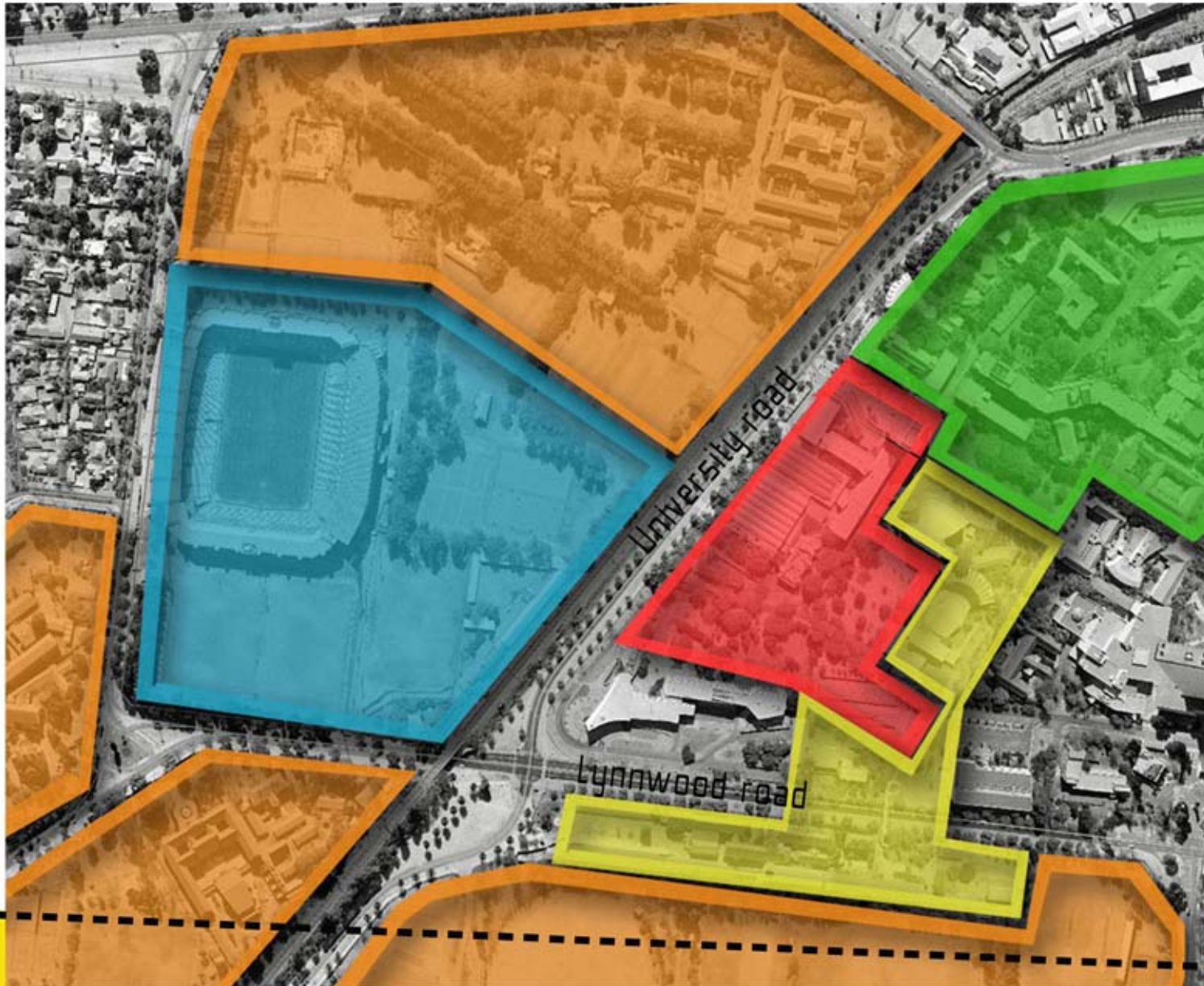

- _ Research Precinct
- _ Arts Precinct
- _ Sport and recreation Precinct
- _ Secondary Academic Precinct
- _ Natural Science Precinct

Districts:

"...sections of the city , which the observer mentally enters 'inside of', and which are recognizable as having a some common, identifying character." (Lynch,1960:47)



District Establishment

-  Sport & Recreation
-  Natural Science
-  Research
-  Arts & Culture
-  Education

04:08





Pedestrian streets

"Streets are the arteries of our communities - a community's success can depend on how well it is connected to local services and the wider world. However, it is all too easy to forget that streets are not just there to get people from A to B. In reality they are the tissue that connects and keeps the urban body of the campus alive. They form vital components of residential areas and greatly affect the overall quality of life for local people." Streets aren't just routes from A to B, they are spaces serving a civic function.

We have proposed four scales of intervention at street level, each of them suited to a different pedestrian environment. One at a main artery scale (fig. 4.20), to accommodate pedestrians comfortably with high speed traffic, secondly traffic calming is introduced around campus (fig. 4.19), thirdly at campus ring road scale (fig. 4.17) to accommodate both intercampus vehicle and pedestrian traffic with prominence being given to pedestrians and lastly at a secondary artery scale to accommodate users within the Loftus precinct (fig. 4.18).

fig. 4.18

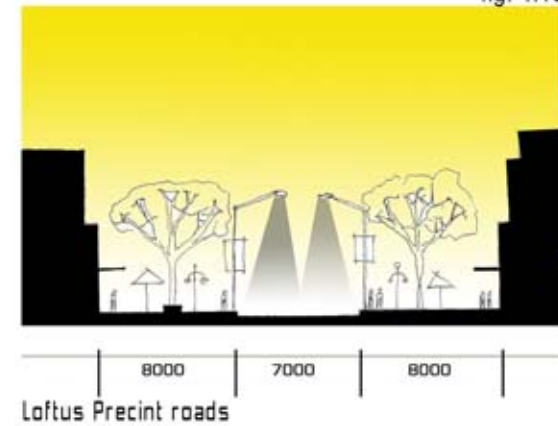

fig. 4.17

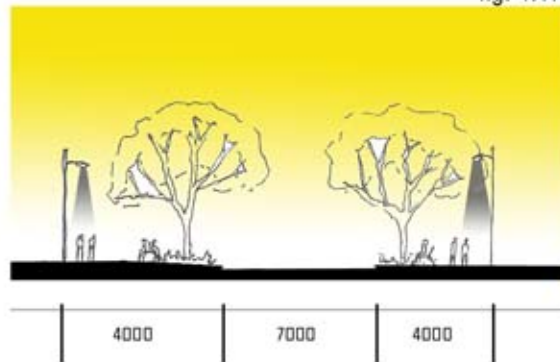

fig. 4.19

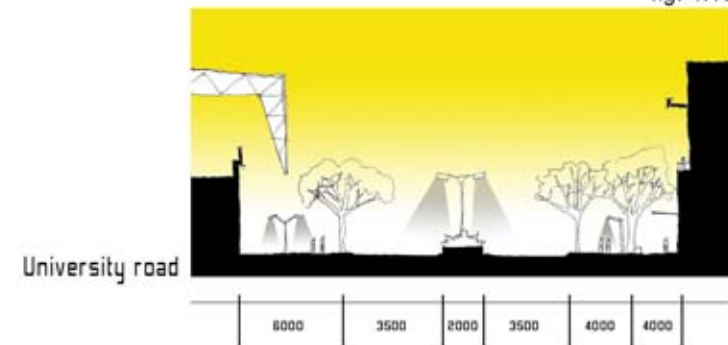
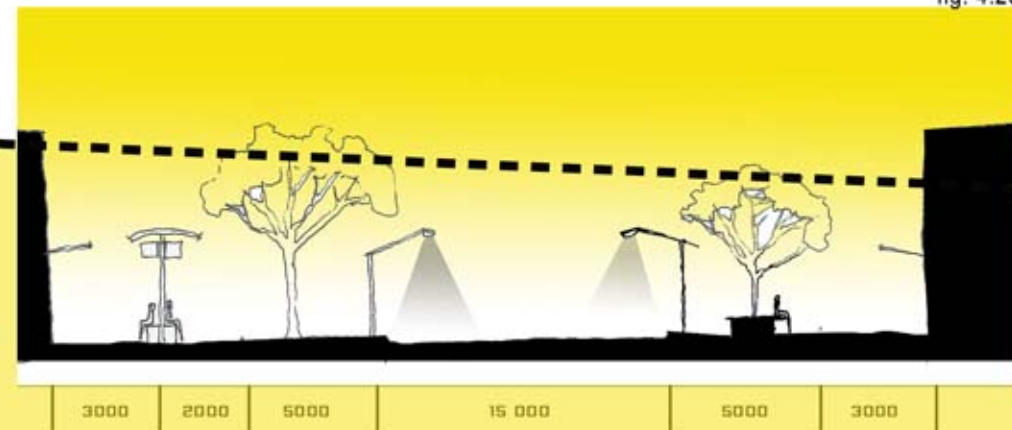
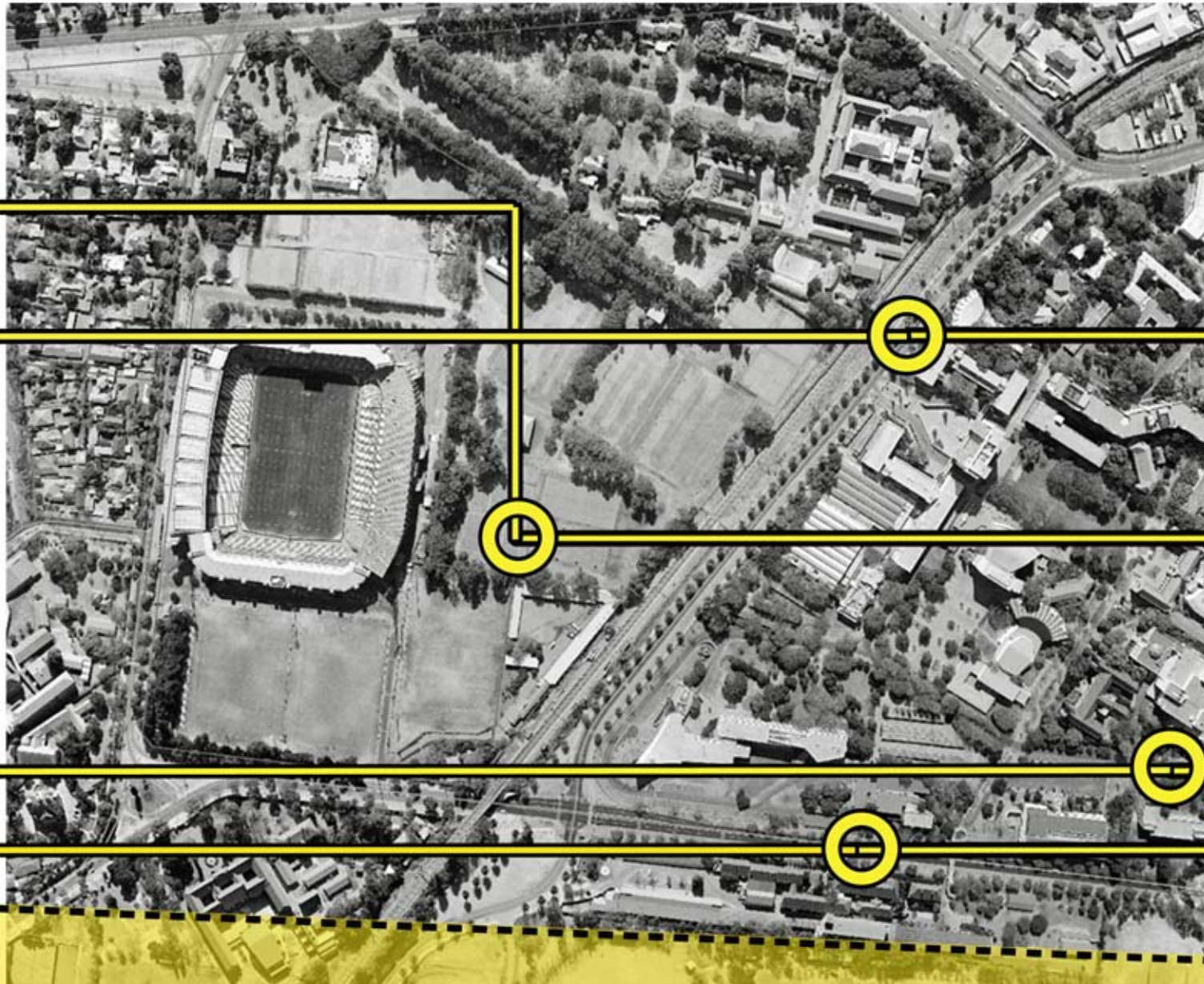

fig. 4.20

Lynnwood road





University road

04:10

Loftus Precinct roads

University ringroad

Lynnwood road





PRECEDENT
PLATFORM

↑ Exit

PRECEDENTS 05:00

Mutual Park West Campus

Warwick Junction

Waterloo Station

Siebersdorf

Southern Cross Station

Piensaarspoort Station

Precedent

PROJECT: Mutual Park, West Campus
LOCATION: Pinelands, Cape Town, South Africa
ARCHITECTS: Blueprint

Influence on dissertation:

Within the urban scale it is important to establish the influence of the surrounding context and the effect on the proposed site. Incorporating the surroundings into the design via physical links e.g. walkways and axis, as well as via visual links e.g. vistas such as Loftus Versfeld Stadium and the University of Pretoria. The use of the courtyard as the nucleus of the building, a communal space where interaction can take place.

Materials:

- _ Sunscreen truss system
- _ Steel box girder
- _ Precast concrete



fig. 5.1_View of courtyard

Description:

The site is at the end of the campus and is situated amongst main roads, sports fields and the railway. The site has beautiful views. West Campus should essentially be a "pavilion in the landscape". Each facility requires its own entrance. Each respective identity can be defined and importance stated. Character of facades is generated by the use of sunscreen truss system that shades the curtain wall glazing, reducing heat load and glare whilst exploiting the view (fig. 5.2).

Transparency throughout the buildings remained the theme of the design.

West Campus is designed in a courtyard arrangement. All facilities relate to this courtyard which is the nucleus of the campus (fig. 5.1). This courtyard is framed by double storey buildings, defining and enclosing the space.

This development is connected to the rest of the campus via covered walkways. This axis is the main circulation route through both Mutualpark and West Campus.

A bridge over the railway sets up another major movement axis that connects West Campus and Mutualpark with the PFS parking decks (fig. 5.3).

The courtyard connects the different facilities of West Campus and provides a large flexible forum space which can also be cordoned off according to need.

05:02



fig. 5.2_Detail of facade

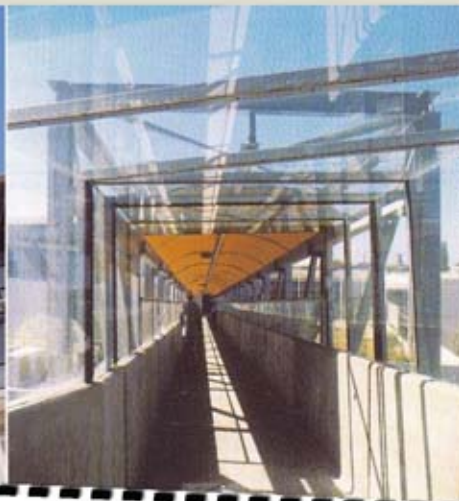

fig. 5.3_Bridge to railway



fig. 5.4_Building entrance



fig. 5.5_Streetscape

Precedent

PROJECT: Warwick Junction, Urban Regeneration
LOCATION: Durban, South Africa
ARCHITECTS: Collaboration of Architects including OMM, MA Gafoor and Kooblal & Steyn

05:03

Influence on this dissertation:

The need for integration of informal trading into a transitional node, such as Loftus Metrorail Station. The immense importance of public services in the urban grain to ensure the stimulation of the users. In doing so the once transitional space becomes a destination place - vibrant with energy.



fig. 5.6_Transition bridge

fig. 5.7_
Traders

fig. 5.8_
Market

Description:

Located on the edge of the CBD, Warwick Junction forms a Gateway to the inner city of Durban. On average, this primary transport mode accommodates 460 000 commuters and at least 5000 traders. Planning objectives were determined and an overall effort between the various architects to create a powerful informal economy in the city. The success of this project is due to the architects' collaboration with the local user. In 1996, council took the initiative to launch a 'clean-up' project, with the focus on a safe environment, trading and employment opportunities.

The surrounding buildings, once unsafe and occupied by criminals were revamped and upgraded into centres for the community providing spaces for dialogue and consultation. Most of the structures erected were within open public spaces, displaying the need for an integrated informal market into the urban plans. The uncontrolled trader facilities were formalized by using the existing vibrant energy of the area (fig. 5.8-5.12). Traditional herb and multi markets were established in addition to the existing live chicken (fig. 5.13), fruit & vegetables as well as bovine & mealie cookery. These open fires used for the cooking of delicacies were replaced by the necessary infrastructure needed for safety. The council was very helpful in the process and today Warwick Junction contributes immensely to the economy of Durban.



fig. 5.13
fresh produce market



fig. 5.12
view over informal trading



fig. 5.9
Courtyard and market



fig. 5.10
Internal market



fig. 5.11
fresh produce market

Precedent

PROJECT: Waterloo Station
LOCATION: London, England
ARCHITECT: Nick Grimshaw

Influence on dissertation:

Passengers are collected and dispersed through the building via communal spaces. The use of a steel lattice truss system to cover a large area over the train tracks. Throughout the building the structure exposes surrounding buildings, giving passengers a glimpse of the culture rich context that London offers. Circulation systems are transparent to make users aware of movement, this is a principle used throughout Loftus Metrorail Station.

Materials:

- _ Steel structure
- _ Lattice truss system



fig. 5.14_Facade detail at int. entrance

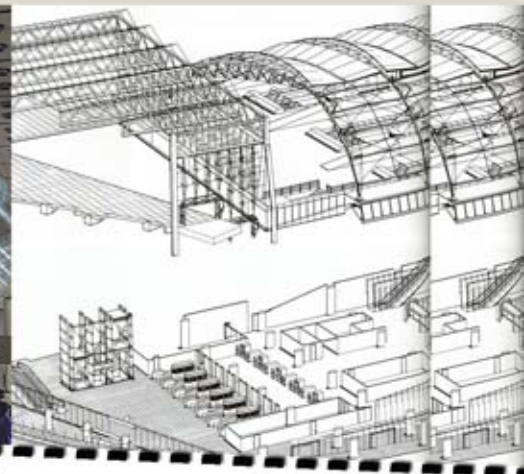

fig. 5.15_
circulation to
platform level above

Description:

The terminal is a response to a novelty of an International train station in Britain, reinventing heroic railroad termini of the Victoria era on a difficult site. The building shapes around a bend, fitting in between the existing station and buildings (fig. 5.20).

As a result, the large S-shape canopy spanning at a maximum of 55 meters. The truss system is internal on the east and on the west. Most of the structural members are standard, that consists of butt welding of steel tubes, rather than plate welding of conventional I-beams (fig. 5.16-5.18.). Below track level the building functions in layers: departing passengers waiting on a mezzanine and arriving passengers moving down ramps to ground level. Both sets of passengers use some of the same circulation pathways but at different times (fig. 5.15).



fig. 5.20_Aerial view of Station



fig. 5.19_ticket booths

05:06

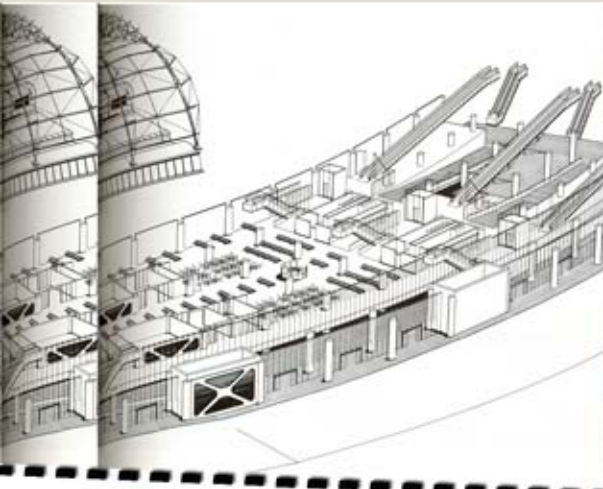

fig. 5.16_Axonometric of structure and circulation



fig. 5.17_Structure



fig. 5.18_Structure

Precedent

PROJECT: Siebersdorf Research Centre and Offices
LOCATION: Siebersdorf, Austria
ARCHITECTS: Wolf, D. Prix, Helmut Swiczinsky

Influence on dissertation:

Different systems were combined in the design. The use of the screening steel frame system as a free standing, independent entity form the main structure as a unifying theme throughout the design.

Materials:

- _ Concrete columns
- _ Steel frame structure

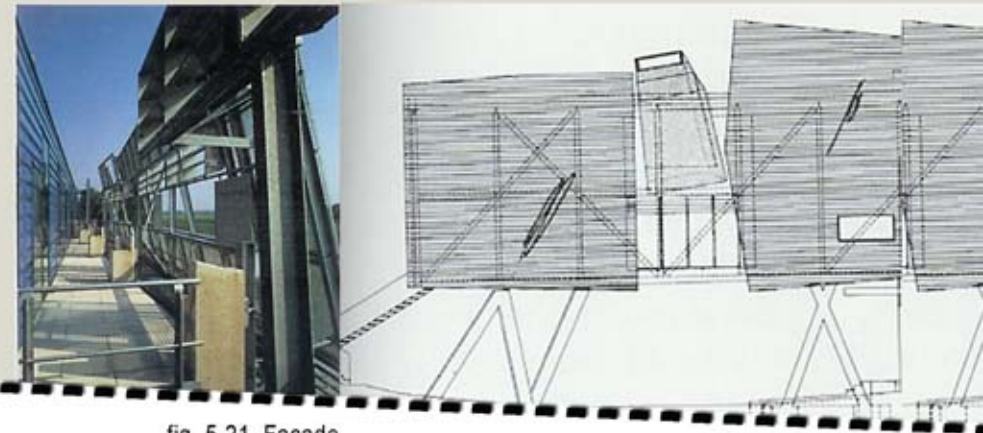

fig. 5.21_Facade



fig. 5.25 Internal view



fig. 5.24 Facade illustrating joints

Description:

The project consists of a refurbishment and extension to existing offices. The building had the peculiarity of involving a variety of professions within the building and it was a prerequisite that the design reflects this.

The presence of different systems at the same time was represented in the structure by overlapping different structural systems (fig. 5.24). Old and new manifested simultaneously on facades of the structure.

Framework of steel structure does not follow that of the main building, but is situated perpendicular to it, and passes above a roadway at one end into the landscape and then launches out into a number of different directions (fig. 5.23).

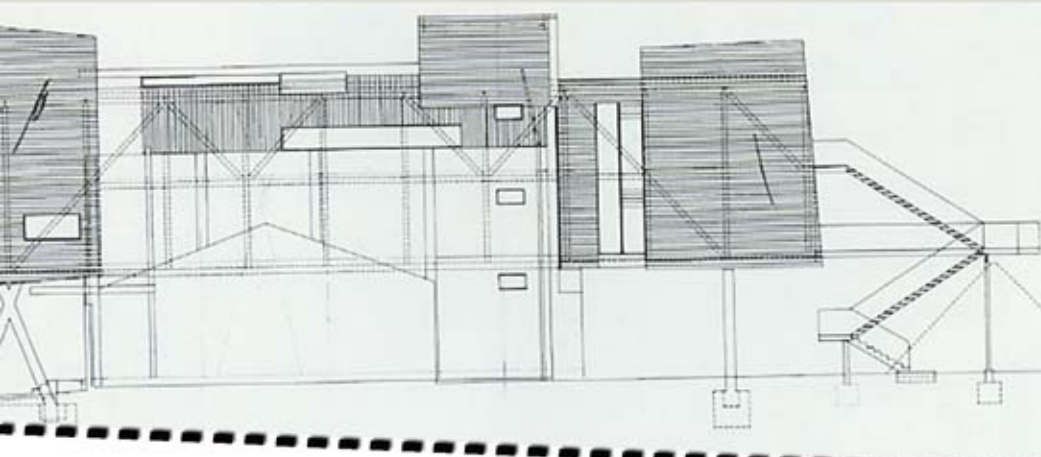

fig. 5.22 Elevation

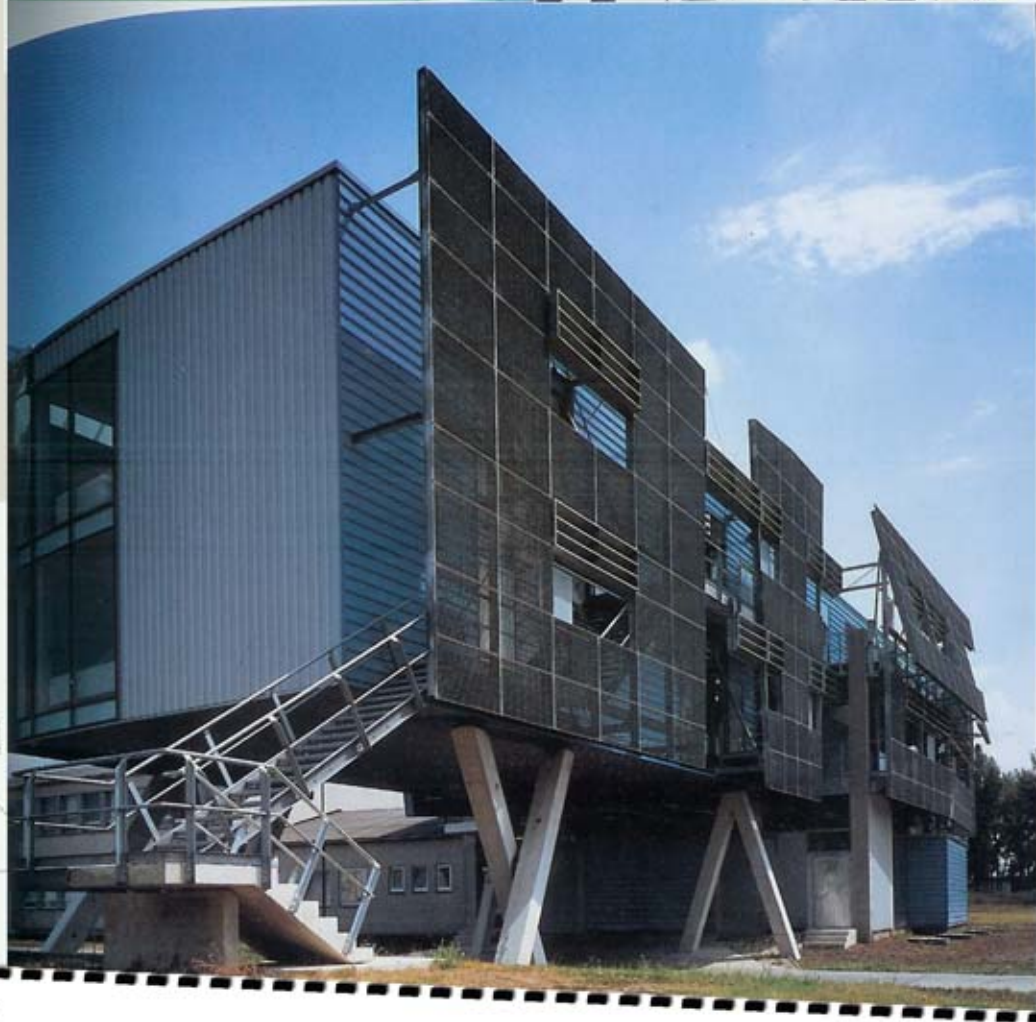

fig. 5.23 Screen facade

05:08

Precedent

PROJECT: Southern Cross Station

LOCATION: Melbourne, Australia

ARCHITECT: Grimshaw & Jackson joint venture

Influence on dissertation:

The use of a vast open roof structure as a station building weaving together two isolated parts of the city; created by the barrier (the railway). The use of steel is preferred due to its quick assembly process. This will ensure that the railway is operational during construction. The open facades of the structure link vistas and the surroundings via the roof structure direction. The directing of passengers is facilitated with natural elements in design such as shadows falling on the platform.

Materials:

- Steel structure
- ETFE roof lights/ polycarbonate sheeting

05:09

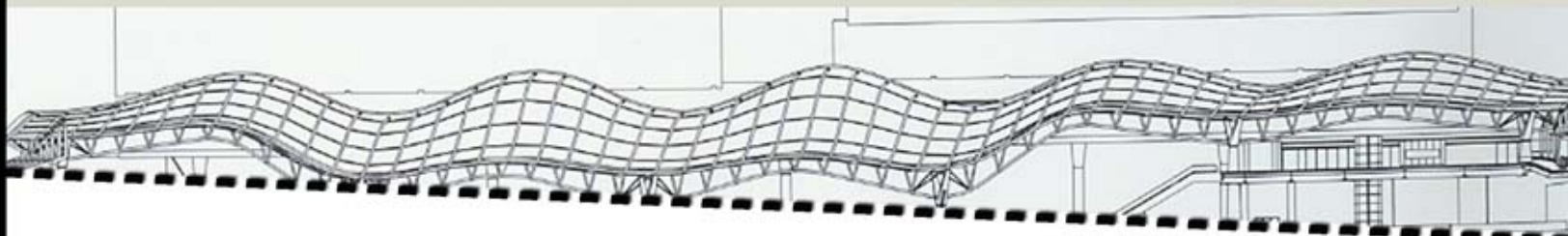

fig. 5.26_Longitudinal Section of Station



fig. 5.27_
Escalator to platform
accentuated by
light above



Description:

The project deals not only with the covering of vast spaces, but also the weaving together of a large part of the city. The railway in Melbourne is laid out along the edge of the dense centre - these railway tracks form a barrier between the old and the new parts of the city. The station is not only a large roof over a transport infrastructure that is open at the sides, but a civic centre - a point of entry into the city (fig. 5.26 & 5.28). The railway is a significant part of the suburban commuter system, and had to be operational throughout the construction process. Columns were lowered onto the platform at night and sections of the roof were held up over the tracks as a result. The roof is visible from the surrounding high rise buildings and becomes part of the landscape (fig. 5.30). From the inside the roof, translucent ribbons of roof lights track along the platforms and direct passengers (fig. 5.27).

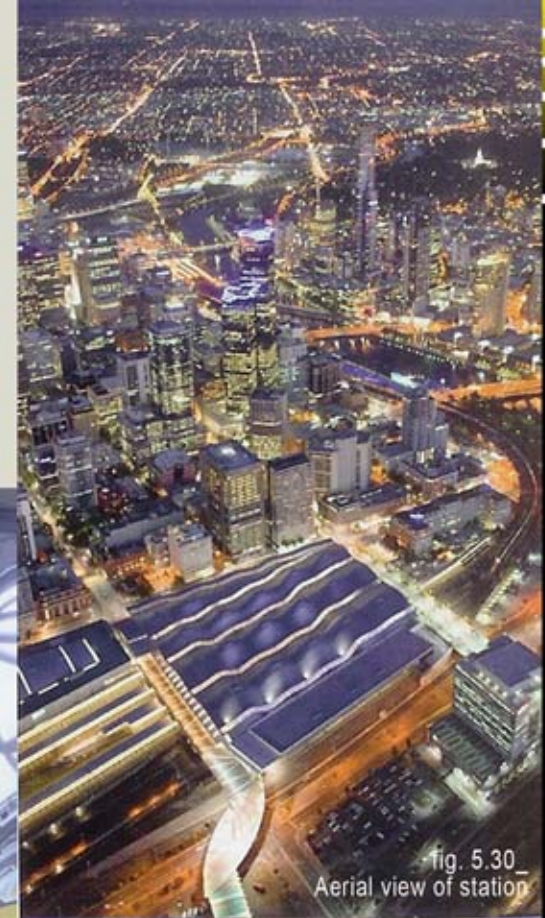

fig. 5.30
Aerial view of station

05:10



fig. 5.28_Overview of station



fig. 5.29_Entrance

Precedent

PROJECT: Pienaarspoort Metrorail Station

LOCATION: Pretoria, South Africa

ARCHITECTS: HolmJordaan Architects in association with Morné Pienaar

Influence on dissertation:

The influence has been immense, due to the client requirements obtained and applied to the project. The progression through spaces and grouping of functions leads to the systematic design principles assisting with the overall legibility of not only this project, but Metrorail stations throughout South Africa. The application of material choices of the station with regard to the climate of South Africa and the comfort of the users, has influenced the decisions made in this project.

Materials:

- _ Steel H-column primary structure
- _ Corrugated steel roof sheeting (Klip-Lok 700 on 1degree roof pitch)



fig. 5.31_
Concourse stairway

Description:

The train station is situated in a rural suburb on the outskirts of Pretoria. The lack of infrastructure in this area proved to be a challenge for the architects. The clients' requirements and guidelines were very strict and safety together with maintenance was the main priority. The passengers enter into a foyer where the administration flank of the station is placed. Passengers buy tickets and proceed passing the security offices towards the concourse to the respective platforms (fig. 5.33-5.35). The architects based decisions of the linear design on the ability of the station to expand. The hall roof structure becomes the icon of the station and all maintenance is done on a service ledge without disrupting the activities on the inside. The primary steel structure of the stations' beauty lies in the careful detailing of each joint (fig. 5.32). The station becomes a landmark in the desolate area where passengers can feel safe and comfortable.

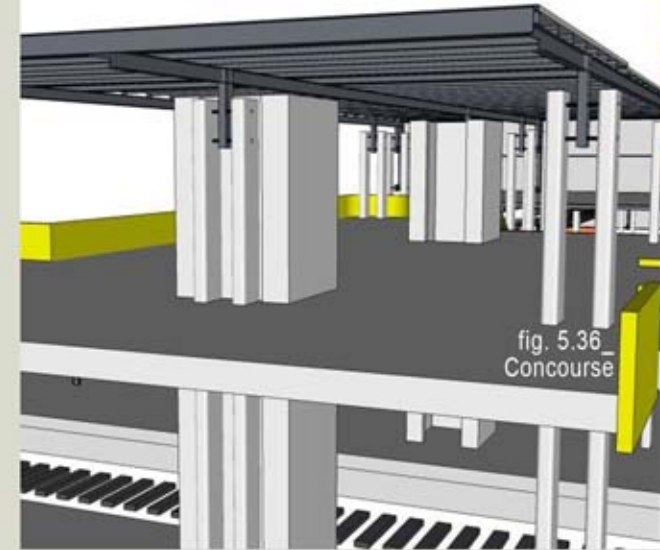

fig. 5.36
Concourse

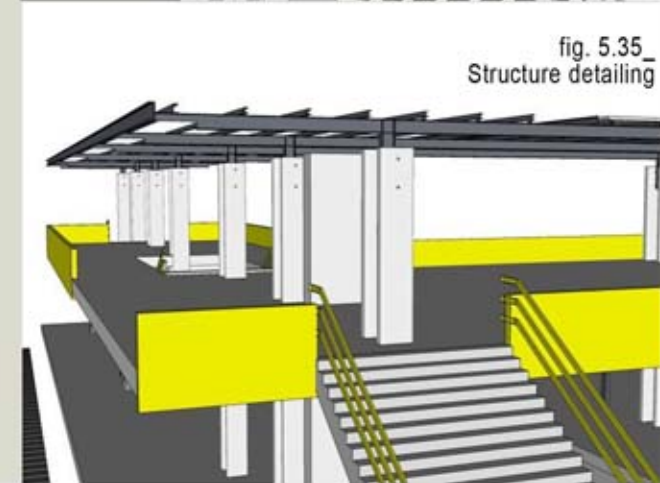

fig. 5.35
Structure detailing

05:12

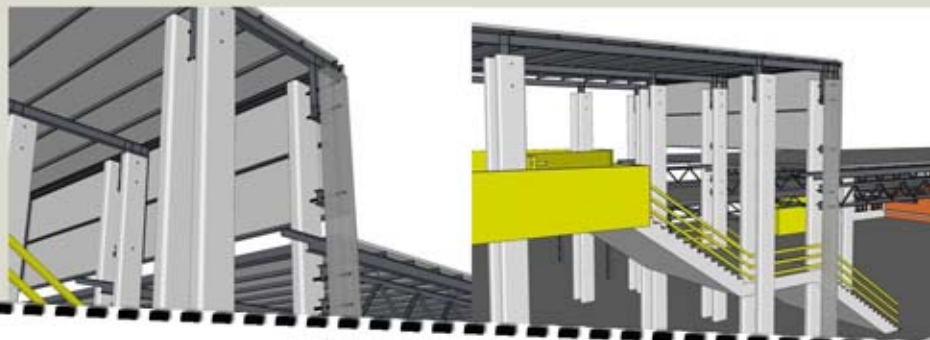

fig. 5.32
Structure detailing



fig. 5.33
Concourse and stairway



fig. 5.34
Station building and railway lines



DESIGN
PLATFORM

↑ Exit

DESIGN DEVELOPMENT

06:00

Design process

Vignettes

Design process concluded





Design Development

The aim is to deal with a diverse spectrum of elements - the train at the highest end of the spectrum coming in at a high speed and on the other end of the spectrum is the daily commuter. Within the spectrum, the station also accommodates the link between Loftus Versfeld city block and the University of Pretoria. All of the above mentioned require a specific design approach best suiting their individual needs. Eleven stages will be discussed, stage 6 include a story line from the users' perspective

- Stage 1. Establishment of the Loftus Precinct development and the green bicycle route for maximum success of the Loftus Metrorail Station.
 - Possible relocation of Municipal depot within proposed Loftus precinct, servicing the green route.
 - Exploration of a pedestrian bridge linking Loftus Versfeld Stadium to the University of Pretoria.
 - Proposal of a slipway underneath the railway for vehicle movement due to limited space for modal interchange on University road.
 - Relocation of passenger tunnel underneath the railway opposite the new student and vehicle entrance of the University. This provides a vista from the entrance of the tunnel to Loftus Versfeld Stadium.
- Stage 2. The exploration of the experience of the user throughout the design was implemented by creating viewpoint vistas through directional lines in the design.
- Stage 3. Exploration of multiple staircases leading the user to the platform, activating the entire edge of the strip. This was problematic because of ticket control.

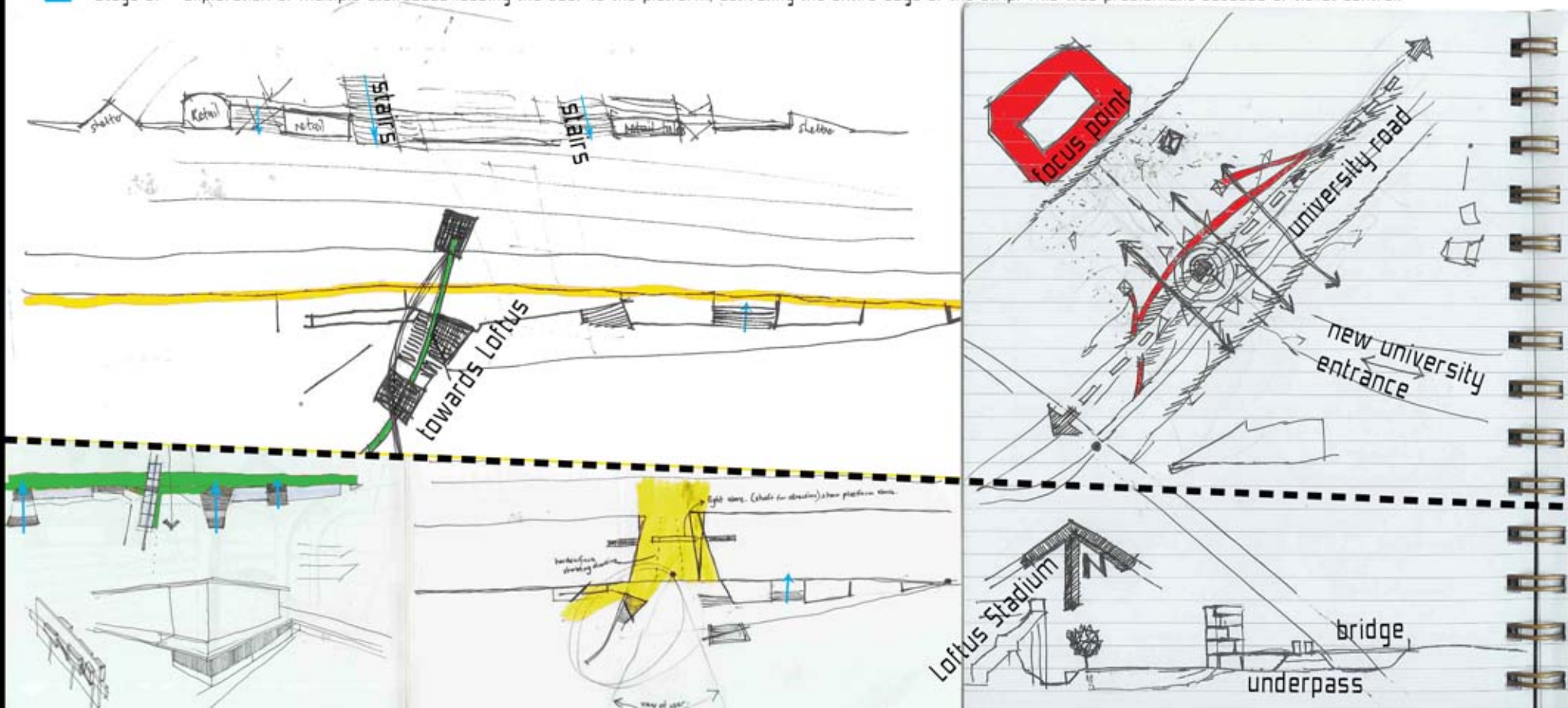

06:01



- Stage 4. Strategic placement of the station control room and the security room in full view of the platform and surroundings
- Stage 5. Activating the edge of the embankment along the existing railway track by placing functions within the height difference. Creating two different spaces of interaction on platform level for 'quick-buy' options.

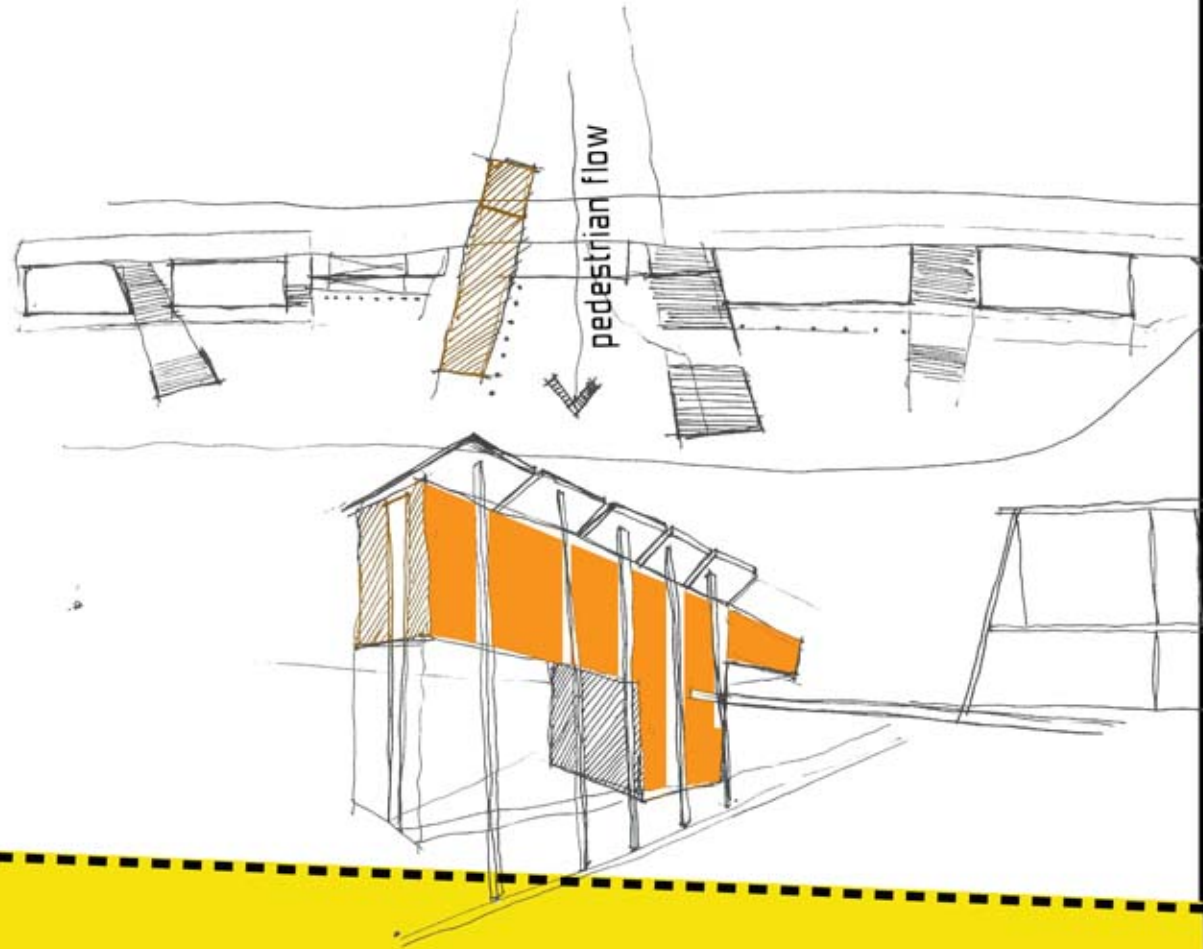
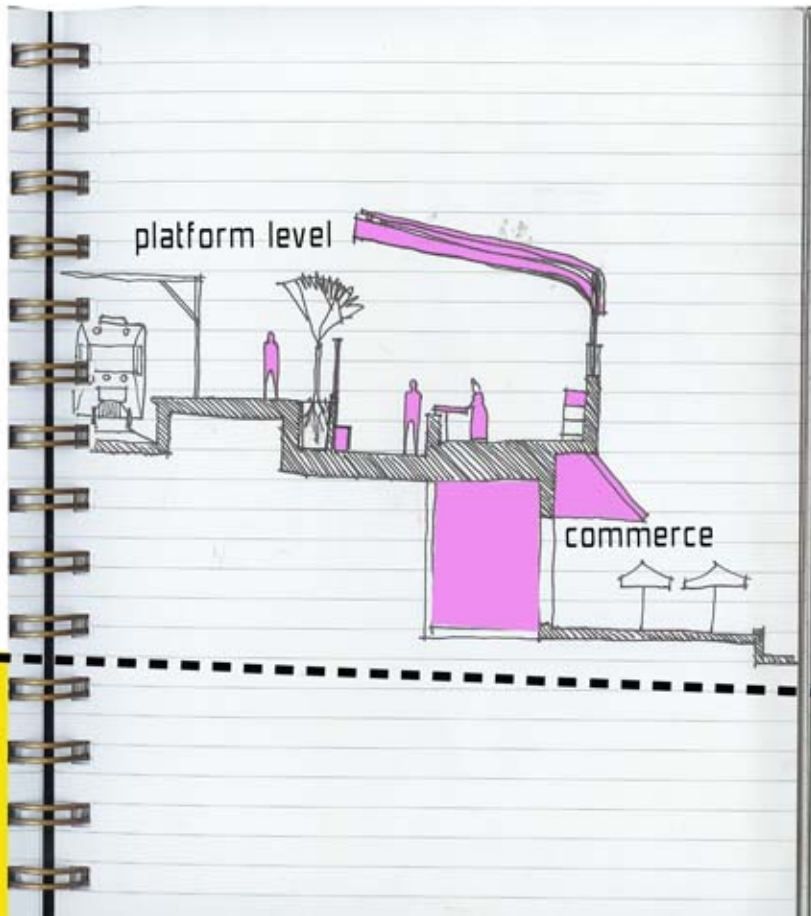



Concepts lack substance in the sense of place. Focus must shift from creating an active platform arcade to designing a station building, focusing on ticket control and security, this became the first turning point in the design process

Stage 6. Plan is simple and legible

- The column grid allows the walls in between to have free form since it needn't be load bearing. This allows free flowing forms suggesting movement on plan
- Structure is open and transparent
- All modes of movement open and translucent for quick decision making
- Public facilities open and visible from everywhere
- Ground level: Shopping arcade parallel to railway, perpendicular to main movement to assist with function identification
- Structure suggests movement, designed to draw user in and disperse into different destinations
- Security points overlook turnstiles, avoiding ticket evasion and improving active surveillance
- Main feed to Loftus Precinct is from the station - therefore direct and uninterrupted access via bridge.

06:03

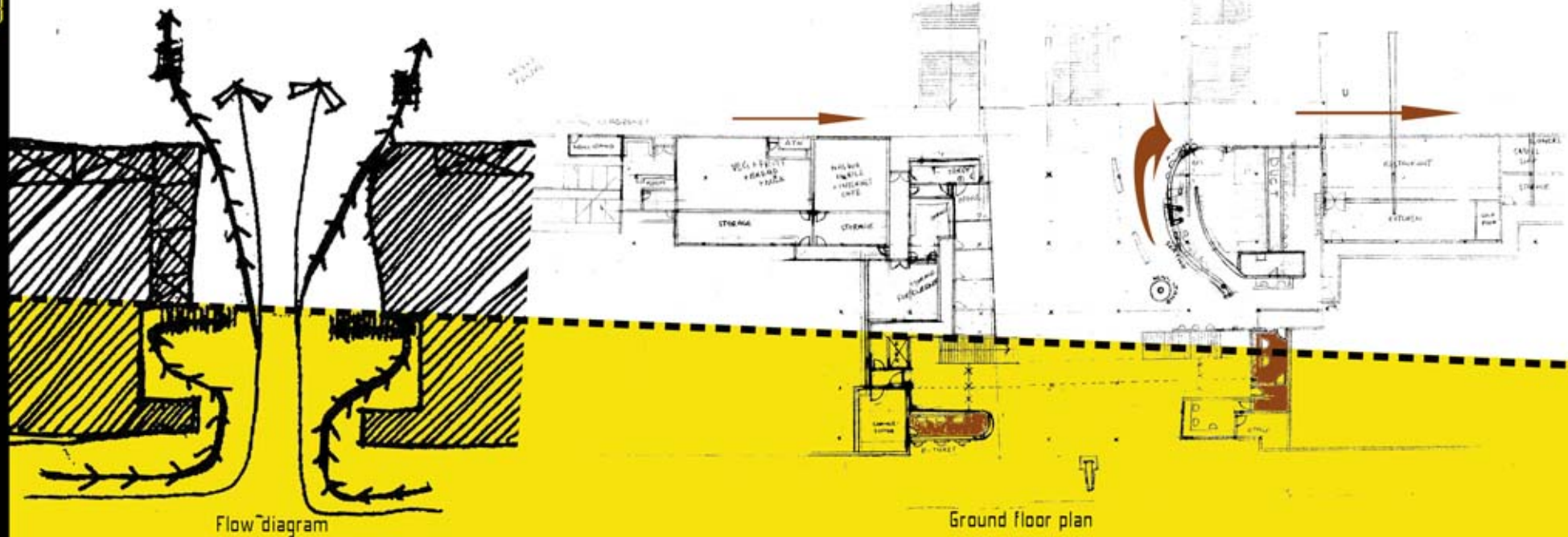

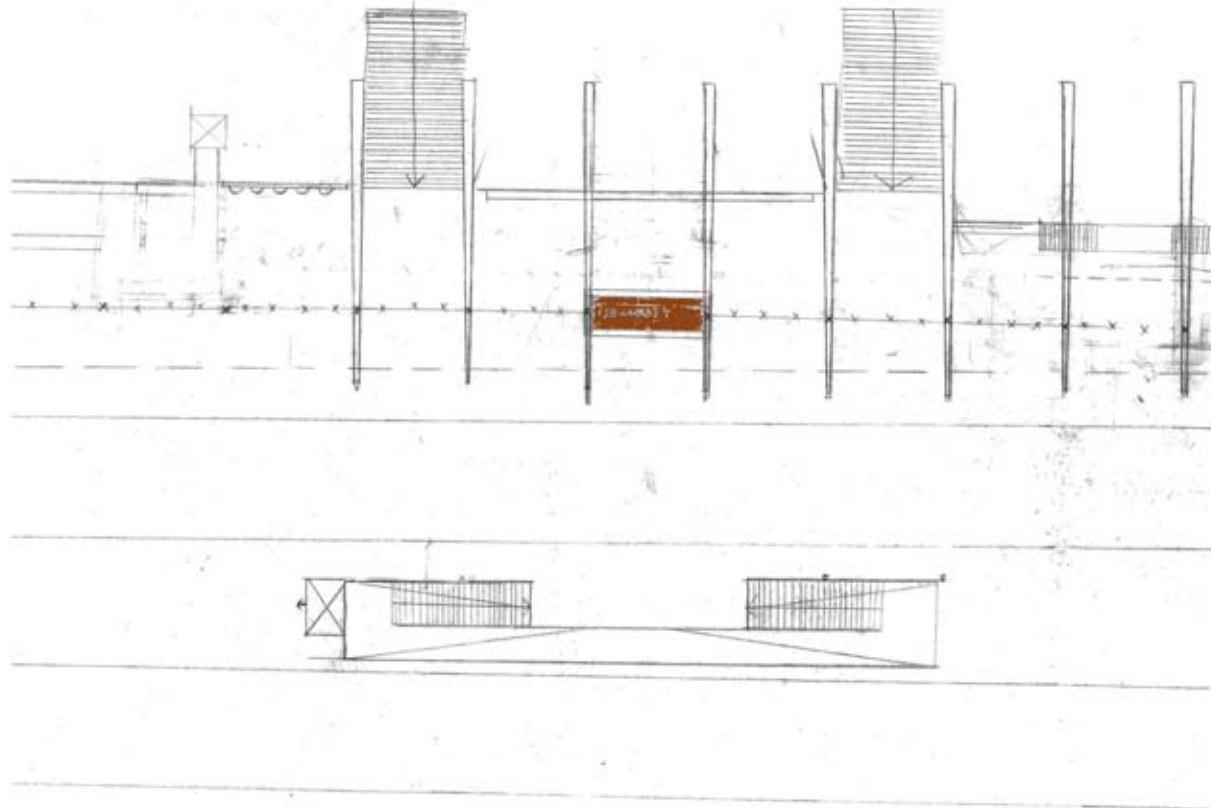

Platform level plan

The Story

In order to understand the simultaneous movement systems in this part of the design process, one has to think like the user of the space. (refer to theory chapter)

Therefore a series of stories, illustrated through vignettes (seen on the next page), were created to express how the different users of the space would perceive it through their own eyes. By establishing a track through space which becomes the actual path and so doing become the dominant organizing force in design.

06:04





The Story:

Scenario 1: Approaching Loftus Station from University road.

Walking on the sidewalk: "I experience big trees along the sidewalk in a long row in front of me. The canopy provides enough shade, together with slow driving traffic - a tranquil space to move through. As I progress forward a few students on bicycles pass me and approach the University entrance via a big piazza where many students are meeting and exchanging stories, perhaps even trading off exam papers for studies. But my focus shifts from the right across the street to right in front of me where a tall tower like structure is flashing a picture of a train, with a time of 14:30 and a name of Hartbees-spruit flashing - it must be for the train approaching the platform. Suddenly more people move in a rush toward the structure..... I must see what it is....."

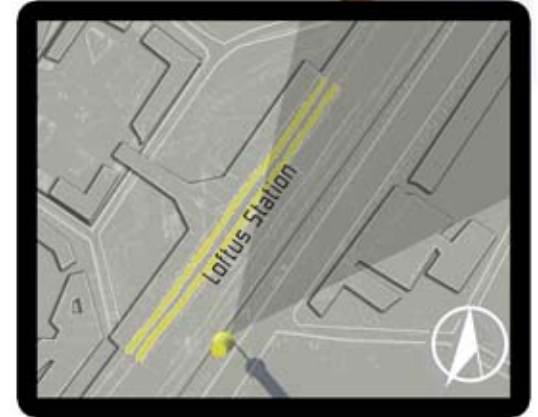



Scenario 2: Arriving at the entrance of the station from University road.

"The building is showing the train approaching the platform. Great! There is the ticket booth right in front of me, easy enough. The man behind the glass partition smiles friendly, I return the smile and walk towards him. There's a lot of activity inside here. Is that the new Loftus precinct that I can see from here? Yes, it must be, because I can see Loftus Versfeld Stadium!

Eventually the informal traders negotiating the prices of their apples return me back to reality. I query the ticket salesman about the next train to the CBD, I'm in luck because the next train leaves in 15 minutes. He informs me that the day pass ticket option can be used for the train as well as the Rapid Bus Rail - nifty!

I thank him and naturally I follow my eyes toward the light penetrating through the roof above - I see stairs puncturing the roof and realize that these are the stairs I need to follow to get to the platform above. Once through the turnstiles - above me I see the familiar yellow movement of the train, the people around me hype me up, and I move quickly with the flow.....I'm excited to see what it looks like up there....."

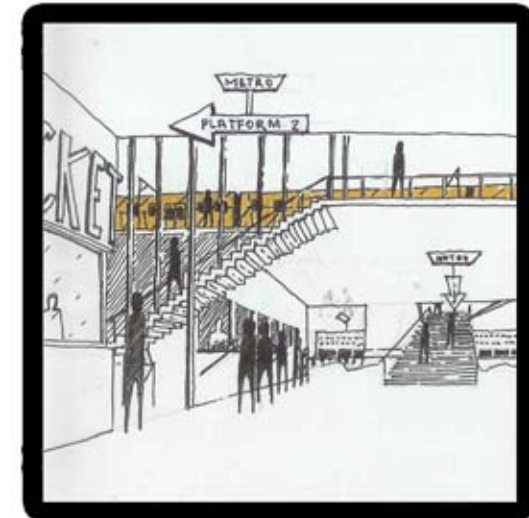



Scenario 3: On platform 2 (CBD direction)

"Once up the stairs, the sheer movement of the masses toward the yellow train entices me toward them, there is a bustling of different characters and classes of people. In the distance there is a man selling peanuts, walking around and echoing the goodness of the protein. I spot another man sitting underneath the structure put up to protect awaiting passengers from the elements. The man is a blind beggar in a wheelchair singing gospel songs and hoping for enough change for day to day living. I always wonder to myself what had happened to such a person for him to be in this situation. I hit reality hard when a rude little boy bumped into me, and didn't bother to apologize. The vibrant array of people makes me feel a strange sense of belonging; I decide to get onto the train before it leaves without me. Once on the train I notice the huge station structure which spills out to the west....I'll have to come back to Loftus Station to see it again...."

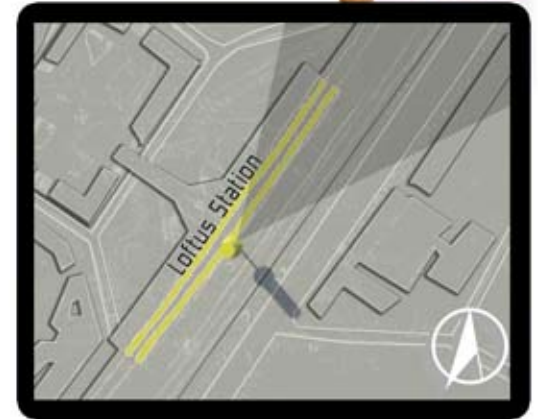



Scenario 4: Arriving at the station via train from CBD (South)

"7am... the train is almost to its full capacity, it's extremely cold today, but in here it's warm, so many people standing close to each other exchanging polite greetings. Four rows in front of me I see a beautiful young girl with her mom trying to memorize her last math formulas before school. Approaching Loftus Station once again, I am reminded about all the soccer games I've attended at Loftus, when seeing the stadium in full glory. The train is starting to reduce its speed and for the first time I can see this precinct sitting comfortably between the stadium and the station. I see a green urban park with children on bicycles on their way to school and joggers with their dogs out for their daily run before work when the platform suddenly comes into sight. I clear the window filled up with condensation formed from my breath to get a closer look. There are many people waiting - but then I see the structure again - it is an inviting structure with the huge horn-like fingers hovering above the platform. Finally the train stops, I'm nervous because it looks so busy - how will I know where to go? The little girl and her mom find their way through the crowded train to the door. I decide to follow them - it seems they know where they are going. But then I see that it is actually so easy to orientate myself with the well known landmark in front of me - Loftus - it should be easy to find my way to Eastwood street, I have a job interview there today at the local restaurant there. The doors open and I wait in anticipation to get out. The feeling is simply amazing...the finger-like structure welcomes me like a mother with open arms, who hasn't seen her child in ages. The movement of people on the various circulation routes seems almost like a well oiled machine. These transparent circulation routes make it easy for me to see where to go - so I go where the structure leads me. Right in front of me I take the stairs down to ground level...."



06:08



Scenario 5: Walking through the precinct from the station

"Normally I would have to walk around this huge block to get to Eastwood Street, but now I notice a big modal interchange in front of me - so I decide to follow the road under the bridge to get to the other side. It takes a while for me to collect myself after a taxi driver nearly ran me over - he better look where he is going - this is a pedestrian friendly area. I get a nod of approval from the traffic officer after I give the driver a piece of my mind. He fortunately apologized and drove away. Again I feel the comfort of the protection that the canopy of fever trees offer on the sidewalk. The florist is busy unpacking his flowers and the coffee shop is already open - the smell of coffee makes me crazy...but I'm in a hurry, so I carry on with my journey. It is so much more convenient now that the city block is open and developed for pedestrians to pass through directly to Kirkness Street passing Loftus Stadium and then right into the direction of Eastwood Street. A sense of familiarity comes to mind, that of the CBD - where I live...where people actually walk to their destinations and rule the street....this is wonderful!"

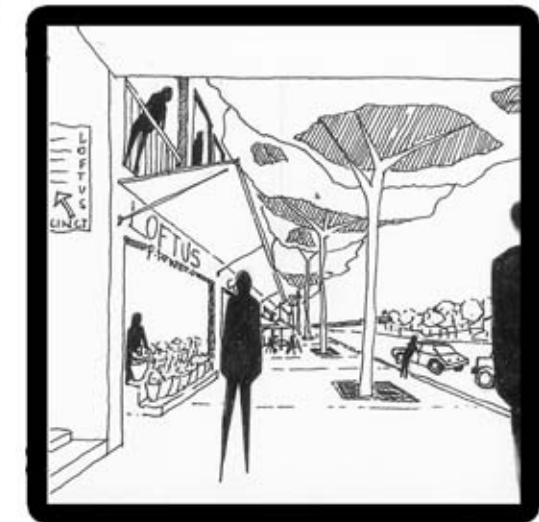

06:09



Scenario 6: A vehicle approaching the station from the underpass underneath the railway tracks.

"I have to be in time for my appointment at nine - I simply have to convince these clients that the V860 will double their return on investment within the first year. The meeting is in Centurion and the train will be the quickest to use. I haven't been to the new Loftus Station: I hear it is very convenient. As I turn left into University road, with the big Admin building in front of me, I remember my student life...AH what a life! But here I am, 42, time really flies when you're a business man with a family to look after. Oh, I see there's a new slipway to the left that passes underneath the train tracks, with a green bicycle route next to it. This reminds me - I need to collect Kevin's bicycle from the shop for his birthday next week. Maybe we should come ride here one Saturday. I see signs underneath the slipway that say busses and taxi drop-off to the left and motorists keep to the right. Parking for the day is also to the left and I quickly change lanes to avoid an unnecessary traffic jam. As I exit the tunnel the new Loftus precinct is unveiled bit by bit from behind the lush growing trees. Platform structures to the right act as trading shelters at ground level. I also spot a bicycle rental and repair shop...this is very clever, now I don't have to attempt to fix the broken chain on my Raleigh. I could just rent a bike and then I'll only have to fit Kevin's new bicycle into the trunk of my new car. My eyes follow the platform structure to the middle, where the structure seems to jump up from the ground up into the air - this must be where I need to go. There's a crowd of people moving in this direction. The bridge in the far end also seems to originate from this point and vanish into the opposite building. The station structure is very large and reminds me of a skeleton.

I can see many different staircases and ramps, this will reduce the time I'll need to figure out the quickest way to get to the train, I always get lost - and everyone knows that I don't ask for directions - I just can't!"

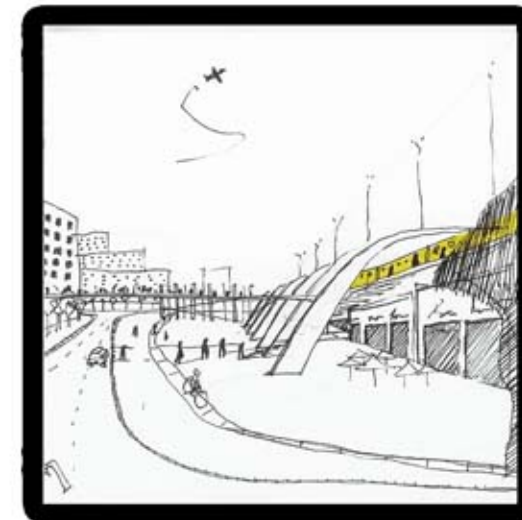
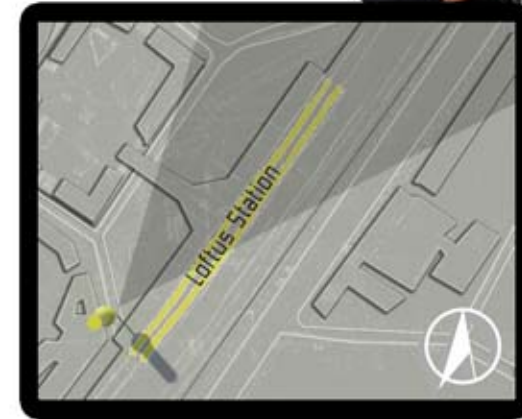

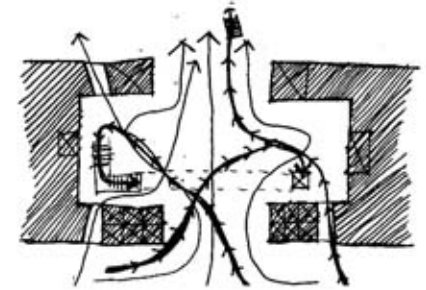

Stage 7. Exploration of 3 dimensional form

- Accommodating western sun treatment through screen structure
- Structure signifies movement and rhythm of the train
- Exploration of the underground shopping area instead of transition tunnel
- Exploration of Western facade treatment
- Structure is open ensuring natural daylight and ventilation
- View of platform is open - exposing movement of train and passengers

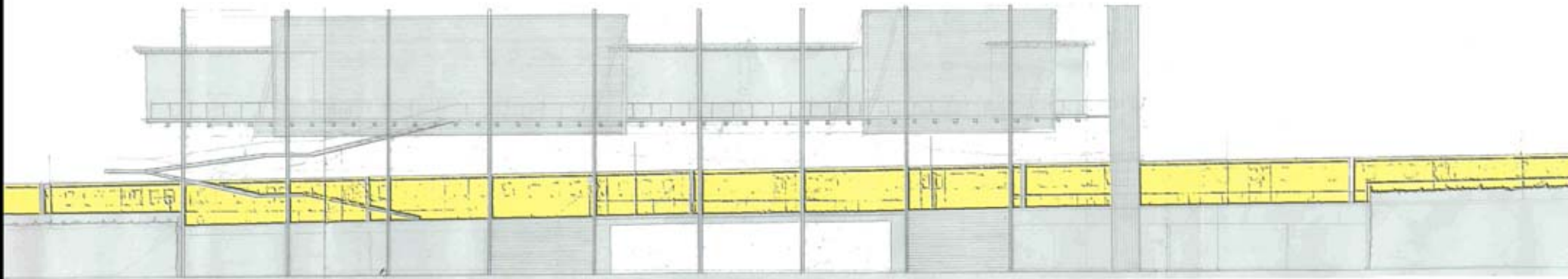

06:11

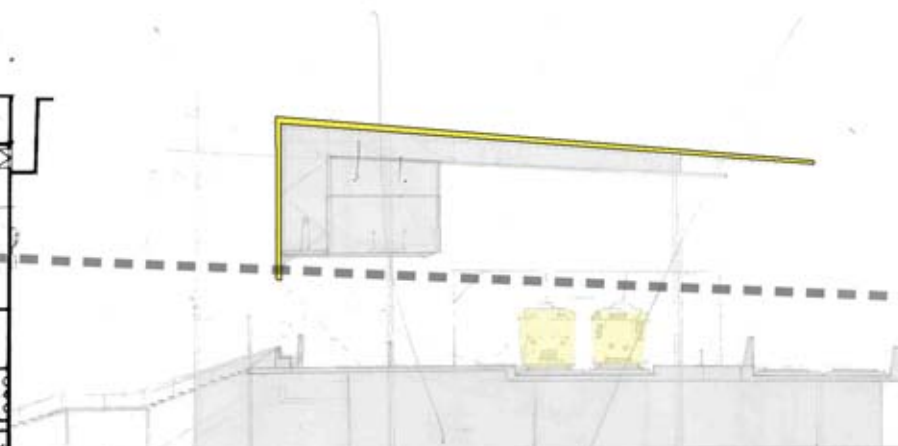
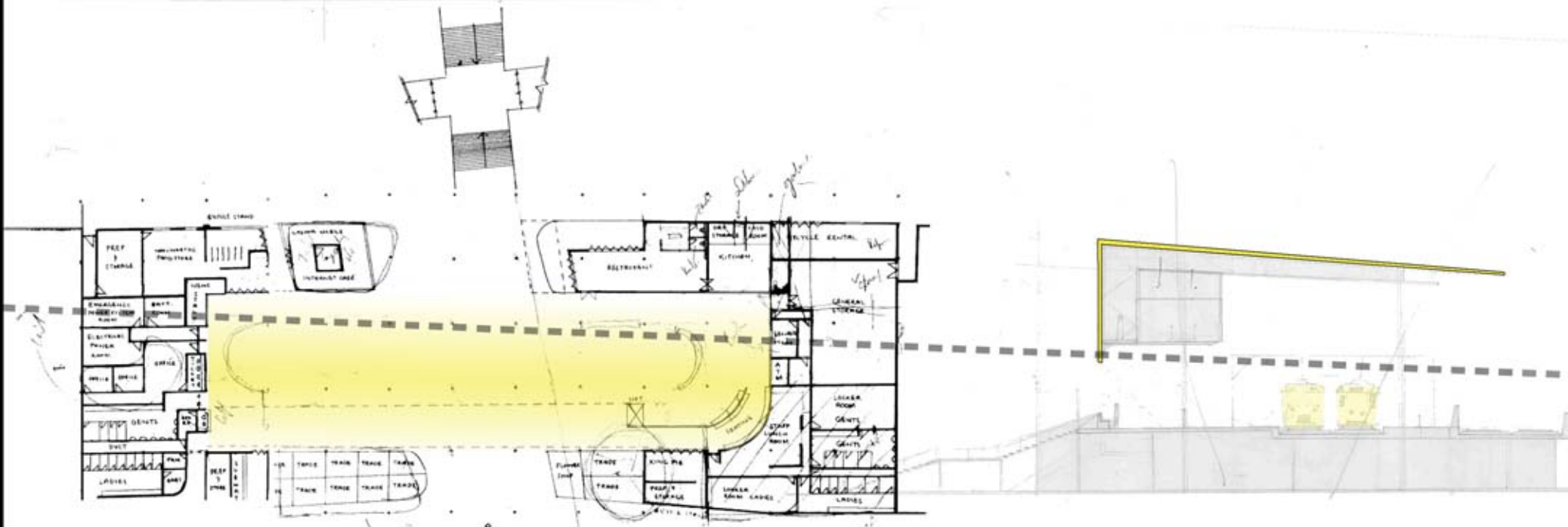



Stage 7 continued...

- Establishment of design policy:
 - That which belongs to the ground: under the railway (shopping)
 - And that which belongs to the sky: platform level
- Treatment of functions and activities in these respective areas
 - That which belongs to the ground: robust, concrete, 'hidden'
 - That which belongs to the sky: lightweight, steel, free structure

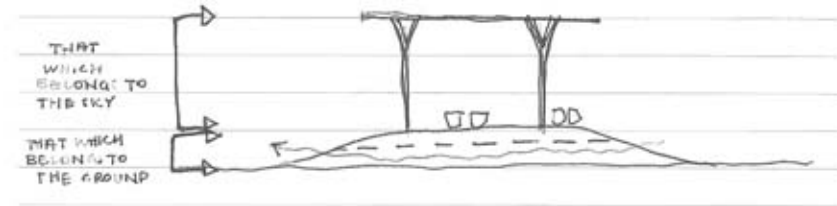

"We may also point out that 'thing' and 'character' (in the sense here used) are dimensions of the earth, whereas 'order' and 'light' are determined by the sky. Time, finally, is the dimension of constancy and change, and makes space and character parts of a living reality, which at any moment is given as a particular place, as a genius loci" (Norberg-Schulz, 1980:32).

- Staff program on Mezzanine level above platform, once again circulation is exposed
- Program on mezzanine level: Security, Station control, admin offices and services
- Mezzanine level: Important functions held here. At the point where the building has substance is where the functions that operate the station are situated
- Circulation remains symmetrical assisting with the legibility of the structure.
- Program on platform level: ticket check, security and seating
- Outskirts of platform (belonging to the ground) evolves into embankment defining boundaries for the structure

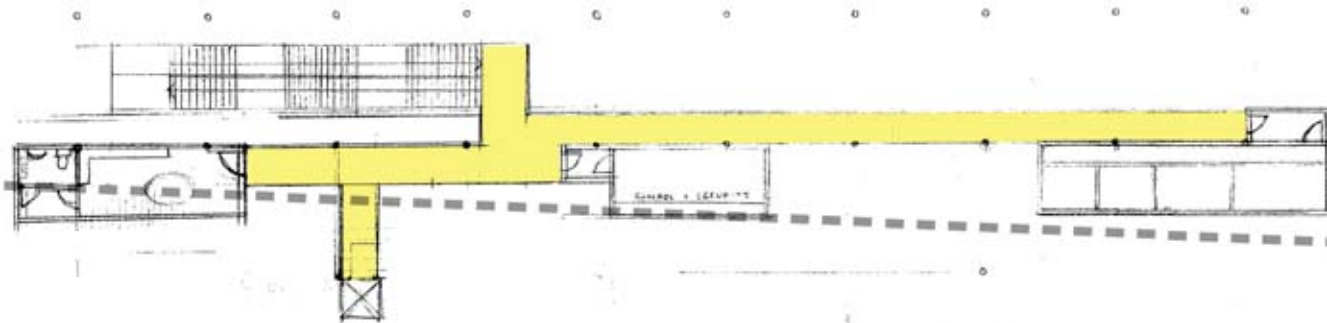

Stage 8. The second turning point in the design process was when the Metrorail design guidelines were obtained and studied. Program adjustment and facility re-evaluation concluded after full understanding of the client requirements.

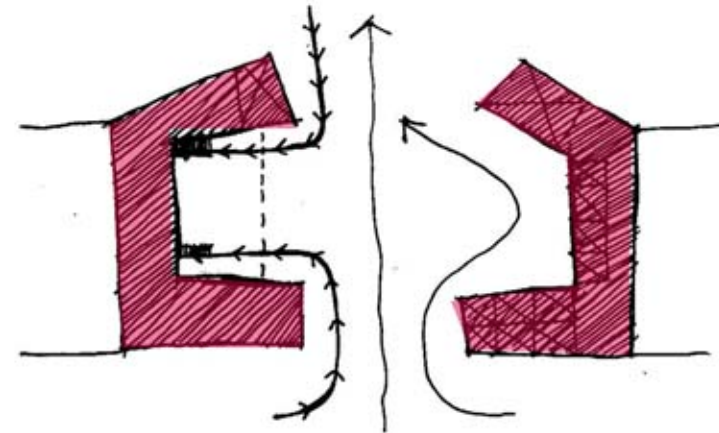
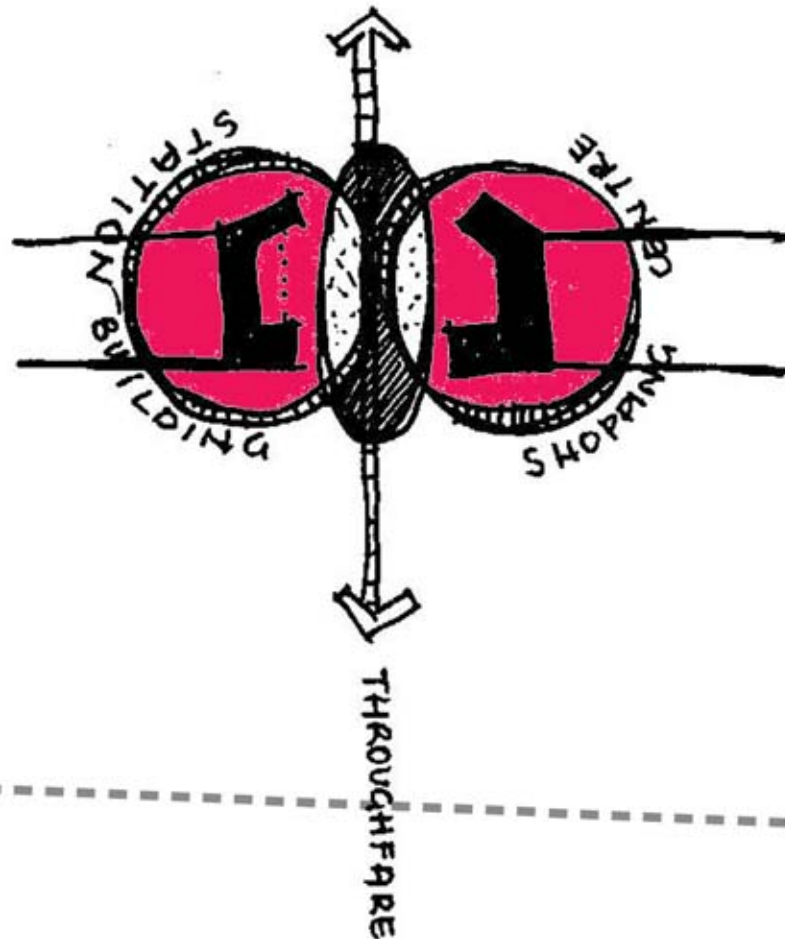

Metrorail requirements:

- Function as independent entity
- Not in favour of commerce within 100m of station building
- Classification of station as a flagship station of medium size (25000-30000 commuters daily by 2025) with a 2% growth per annum
- Stairs to platform to be 3.5m wide
- Maximum safety in terms of design
- Clear opening to entrance of concourse, must accommodate peak volume of 5min period: 7m width of clear entrance
- Internal Hall area: Spatial requirement for queuing: 120m²
- Depth required on approach side of turnstiles: minimum 6m
- SNP lifts: 1lift per platform, situated in view of security points.
Lifts are for SNP's and staff only.
- Four main flanks in station building:
 1. Administration Flank,
 2. Commuter service Flank,
 3. Security Flank,
 4. Plant room Flank



1. Administration flank (customer service centre)

- Ticket sales office with 4 ticket sales points: 16m²
- Default ticket sales point with security office overlooking turnstiles located directly opposite this point: 8m²
- Battery room - back-up power for turnstiles: ducting to turnstiles and control room: 8m². Requires venting
- Station control room: control of turnstiles, PA announcements, telephone systems: 7m²
- Entrance to ticket office: secure cubicle with electronically operated gate as anti-room to ticket office: 3m²
- Cash up room which is a secure cubicle: 2m²
- Strong room with concrete roof, cash drop in safe, office safe: 2m²
- Locker room: 10m²
- Kitchenette: 20m²
- Staff room adjacent to kitchenette for discussions and briefing: 15m²
- Senior clerk's office: 6m²
- Admin store: 12m²
- Staff toilet: 1wc and separate 1whb: 7.5m²

2. Commuter services flank

- Provide for SNP's (special needs person)
- Female: 3 whb and 3 wc of approx 10m²
- Male: 2 whb, 2 urinals and 2 wc's of approx 10m²
- SNP: 1 whb and 1wc of approx 3.5m²
- Cleaning store: 9m²

3. Security Flank (situated in full view of turnstiles)

- Security offices on operational side of station: 7.5m²
- Supervisor office: 7.5m²
- CCTV Surveillance room: 7.5m²
- Charge office: 10m²
- Holding cell (3): 4m² each
- Strong room for storing of equipment with concrete roof
- Kitchenette: 9m²

4. Plant rooms:

- Emergency Power system room: 10m²
- Electrical Power room: 10m²

Stage 9. Primary route through the two separate forms which is the station building and commercial zone separates and feeds the independent entities simultaneously.

- The ticket office becomes the first point of reference to be seen from every point in the building - the destination of the station building
- Secondary routes all lead to the ticket office creating focus points
- Trading is used to create a continuous edge along University road entrance. To prohibit obstruction of strategic vistas, translucent material is allocated to the trading structure.
- Only one entrance to platform via turnstiles, in direct view of staircases leading to respective platforms on the level above
- Staircase locations are determined by the railway standards. Exit points of stairways not to be within 3m of the respective railway tracks and therefore have a limited space to exit on to. This limitation automatically ruled out the possibility of escalators.
- Circulation axis on intermediate floor level punctures through the building allowing natural daylight to penetrate at the same time creating surveillance.
- Circulation options are comprehensible to the user
- Services such as plant rooms and toilet ducts are placed on the outer limits of this internal building for easy maintenance out of the public eye.
- Anchor tenants such as the restaurant and pub are strategically placed promoting active edges, passive surveillance and movement in between these anchors.
- A diverse range of shops are chosen to cater for time-pressed users and timeconsuming users, concurrently providing for different varieties of people utilizing the station.

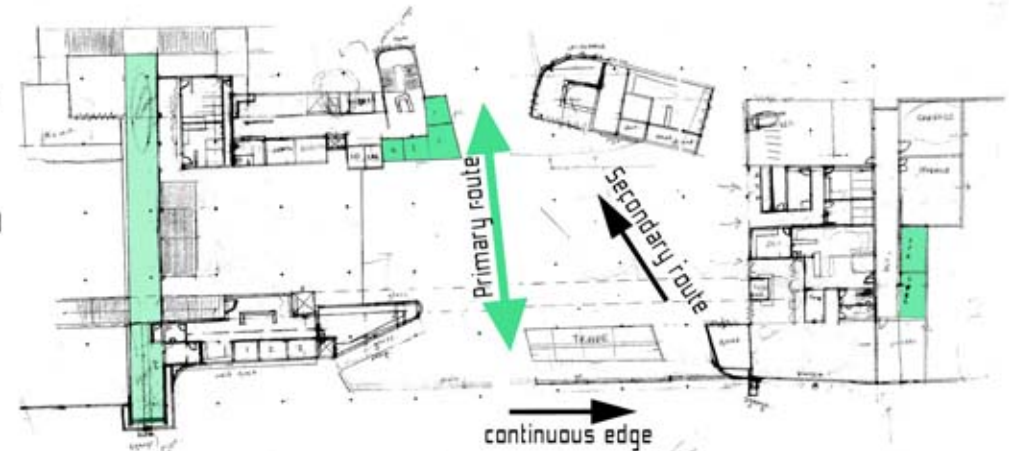
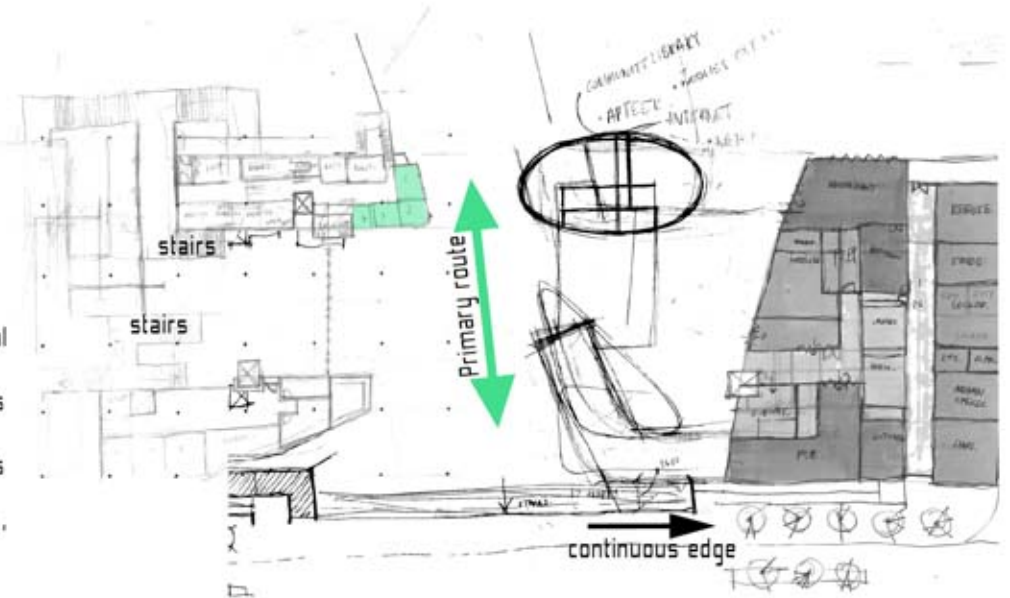

Drawbacks:

- Division of primary route causes division of main mass movement along main spine.
- Too little natural light penetrating the building due to width of railway and platforms, in spite of double volumes created to allow additional natural daylight into the building
- Form needs exploration
- Internal circulation and public facilities placement not conforming to legibility policies formulated in the theoretical discourse.
- Deliveries and service yard problematic.

Stage 10. Realigning and scaling of secondary routes

- Merging of internal staircases improving ease of movement alleviating congestion at peak times
- Placement of security view point on intermediate circulation level within security flank expanding the surveillance area.
- Exploration of service and delivery quarters at commercial zone, including placement of management offices

Drawbacks:

- Natural daylight not adequate
- Trader stalls need simplified form
- Public facilities are isolated and hidden from view
- Service yard is in the line of site and unattractive
- Entrance to Administration flank is problematic - should not be in main axis of movement
- Management offices restricts valuable shop front space

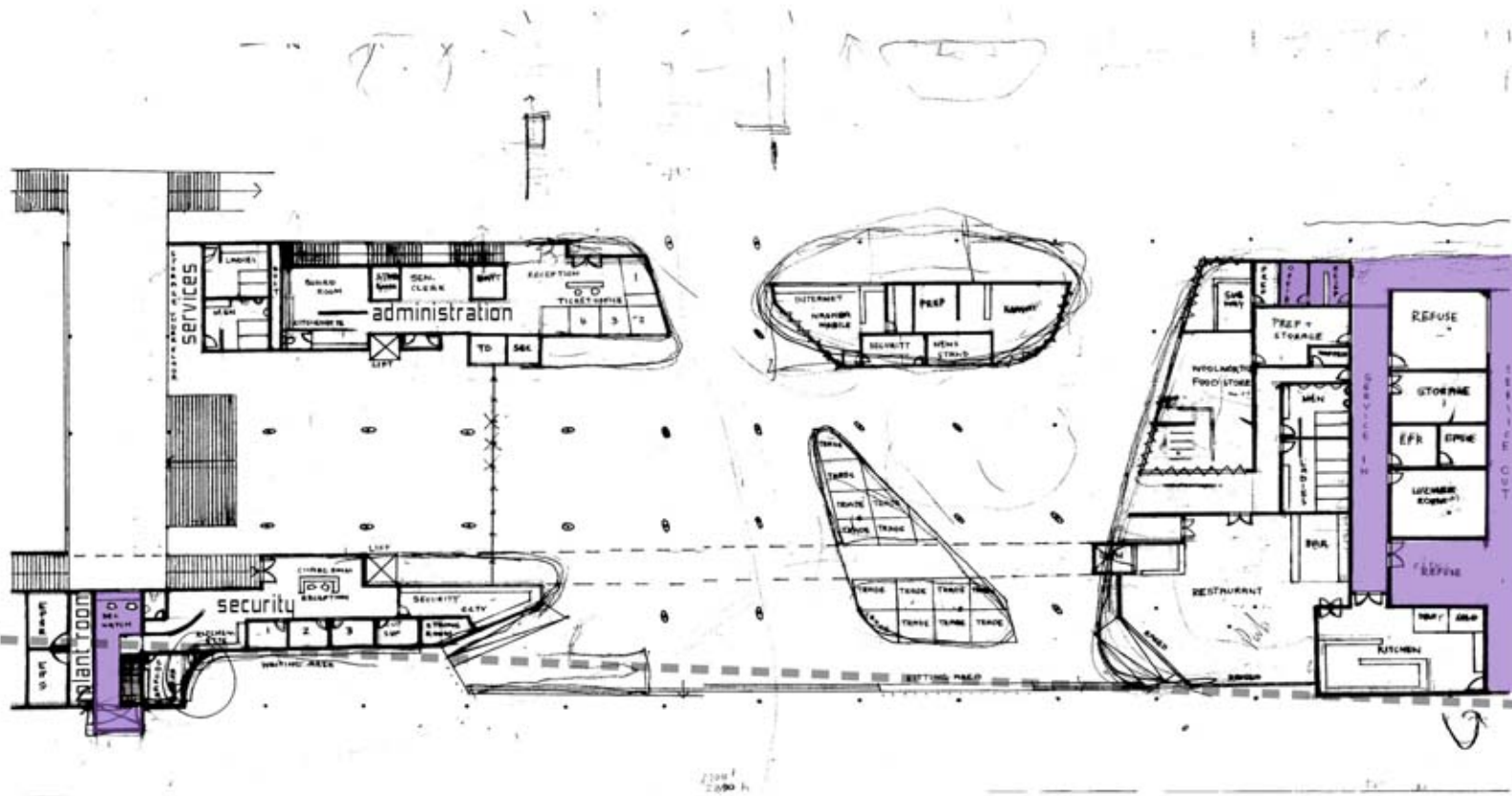



Stage 11

- Decision to lower level of station building to obtain a higher floor to ceiling height of 6.5m resulting in optimum natural daylight into building
- Allowance of appropriate intermediate circulation route elevation above ground level. Resulting in enough height to place public facilities underneath the above mentioned circulation level. This places the public facilities in communal area in line of site, providing necessary surveillance.
- Building courtyard introduced by this accentuating of the axis from station to Loftus Precinct, where flea markets and events can occur. The courtyard gives the building the sense of arrival it lacked before.
- This courtyard provides spill out spaces for the restaurants and shops on the edge of the building.
- Terraced seating is provided facilitated by the slope progressing to the modal interchange in the direction of Loftus Precinct.
- Main feed restricted to the primary route provided by limiting secondary routes through the building dividing the masses.

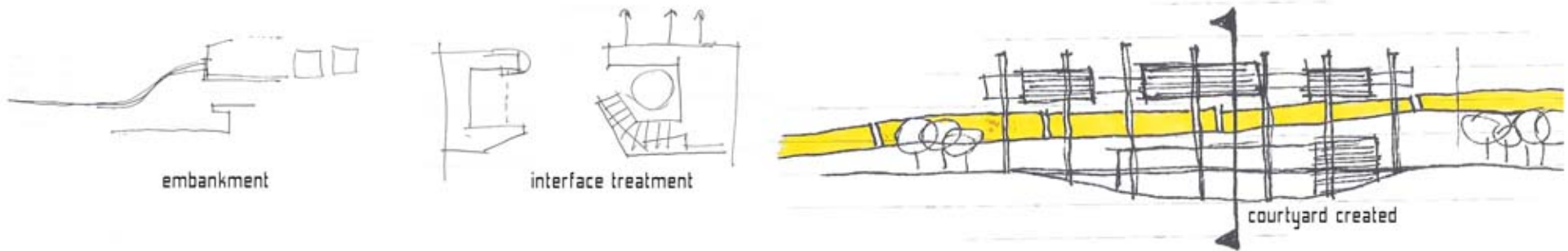

06:17

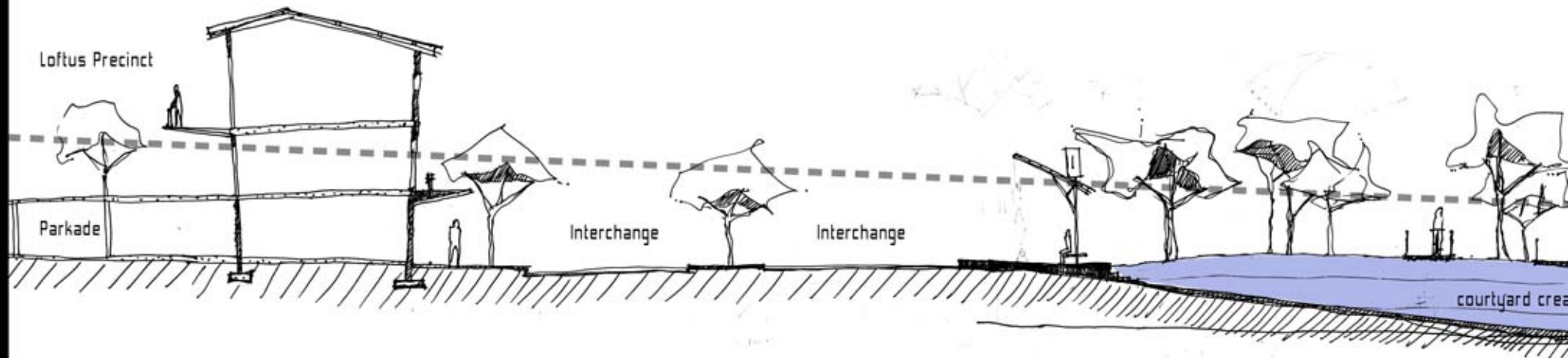



Drawbacks:

- Building edge lacks interface between inside and outside
- Western facade of building problematic due to hot afternoon sun
- Roof structure ignoring University road due to slope

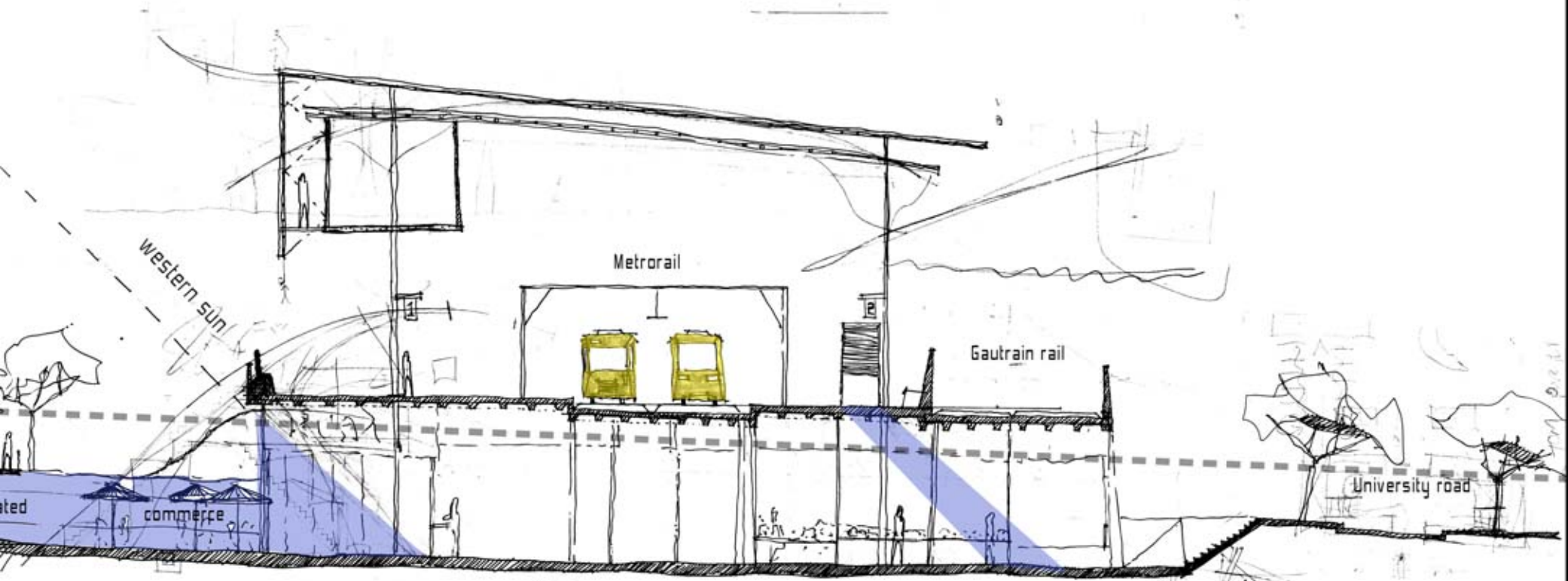
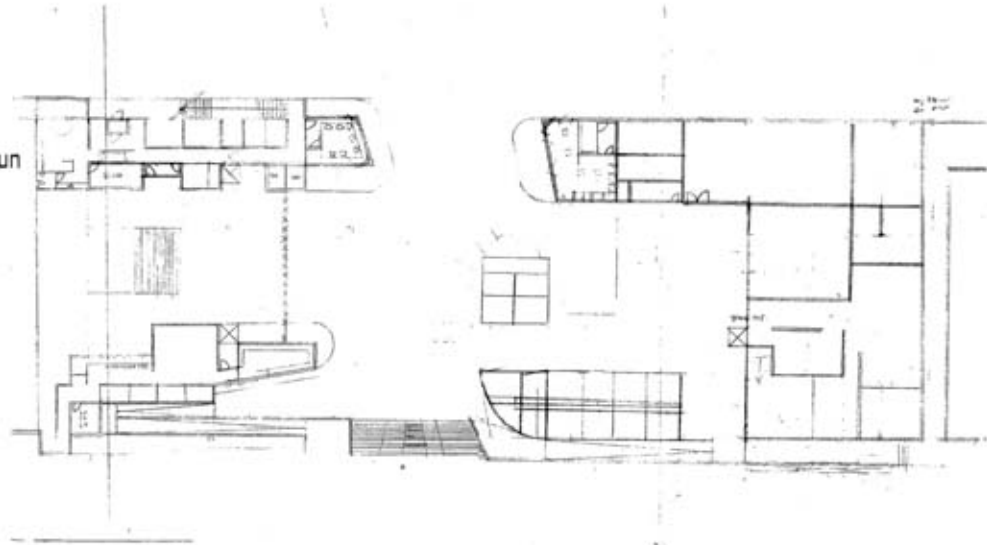



TECHNICAL
PLATFORM

↑ Exit

TECHNICAL INVESTIGATION

07:00

Concrete sub-structure

Concrete slab structure

Steel structure

Box

Screen

Circulation detail



screen

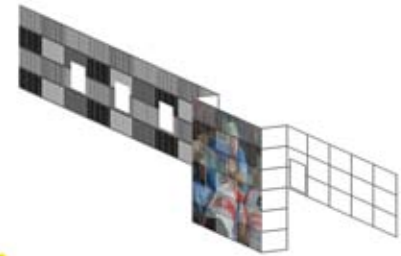

07:01

The building has been grouped into the various structural components. Illustrated in this figure is the extrusion of these elements and in this chapter each component will be discussed



box offices

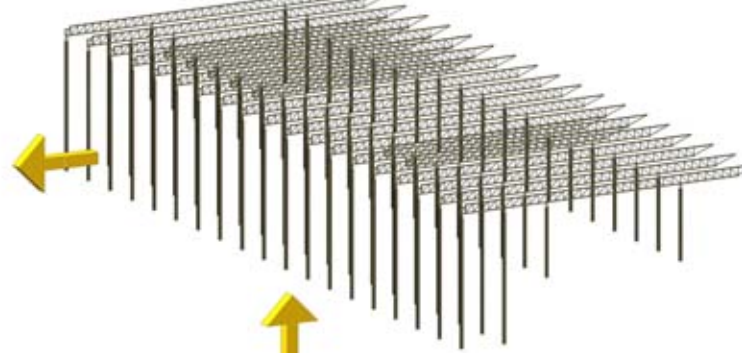

steel
structure

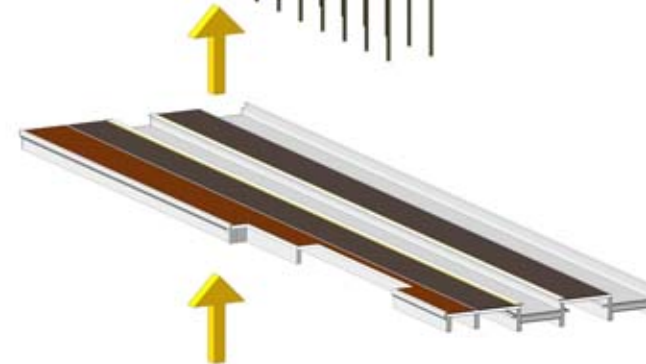

concrete
slab structure

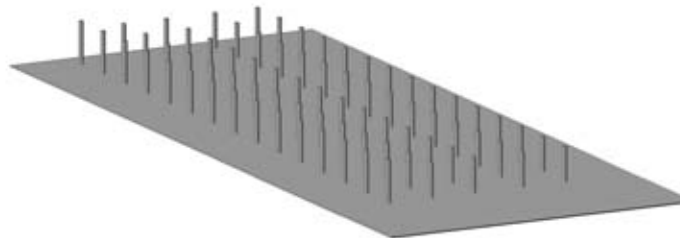

concrete
sub-structure

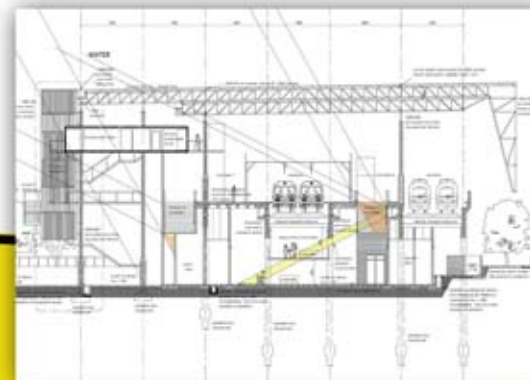

building



concrete sub-structure

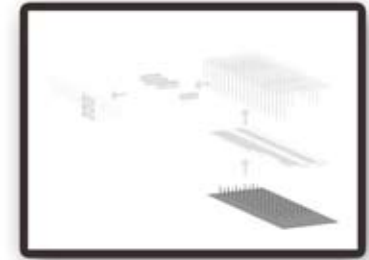

The train:

The train approaches the station at 60km/h and starts decreasing speed 400m away from the station, thus coming into the station at a relatively low speed, according to Mr. Richard Bercher (Chief Engineering Technician of Metrorail. Interview: 15.05.08)

The train weighs 16tons per axle thus at any point on the track the weight of 64ton (4axles) needs to be taken into account (fig. 7.1).

This means that the train requires a robust structure that is able to bear the high mass and movement of the train.

Thus a reinforced concrete base structure was chosen, because of concrete's compressive strength, robustness and resistance against fire.

The combined concrete base consists of concrete piles, precast concrete beams under the railway tracks and a two-way coffer slab carrying the platform area (fig. 7.6).

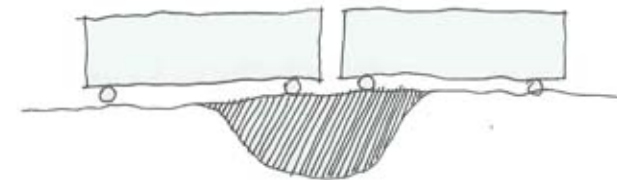

64 ton load

fig. 7.1

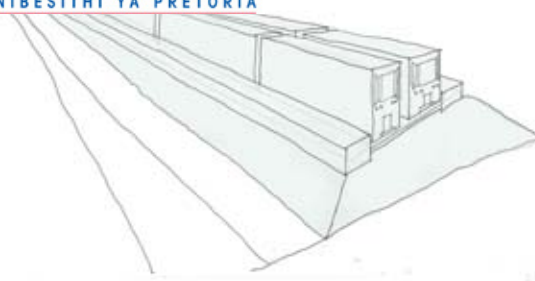

The concrete piles are driven into the ground on a 7x7m grid. This grid size is determined by the railway track's width in section (6.7m) and the space needed for the platform areas in between. Because the train has to remain operational throughout the project, piles were the best option. The choice being between piles and in-situ slabs.

Phase 1: drive piles in at night time to the desired depth (according to engineer Carl Von Geysso: approximately 23m)

Phase 2: Place scaffolding supports underneath the tracks

Phase 3: Dig away the mound of earth that the train rests on

Phase 4: Tank and cast the surface bed on the new ground level.

Phase 5: Place precast beams on top of the piles acting as pile caps.

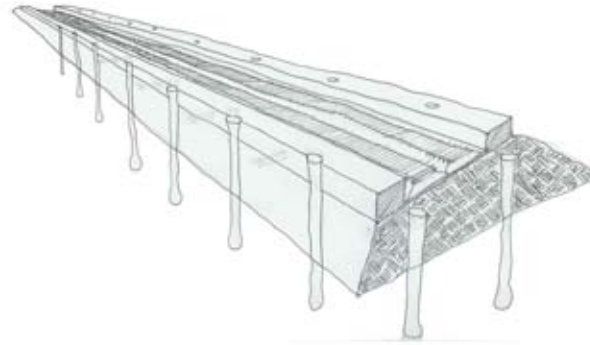

phase 1

fig. 7.3

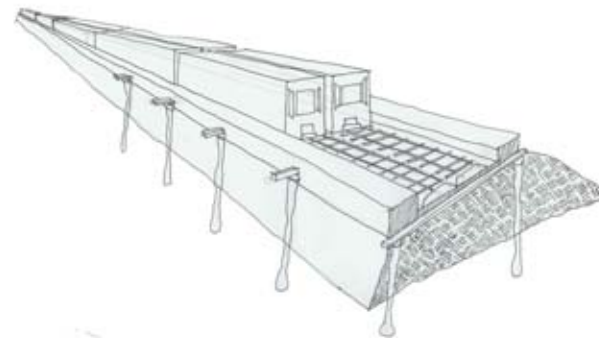

phase 2

fig. 7.4

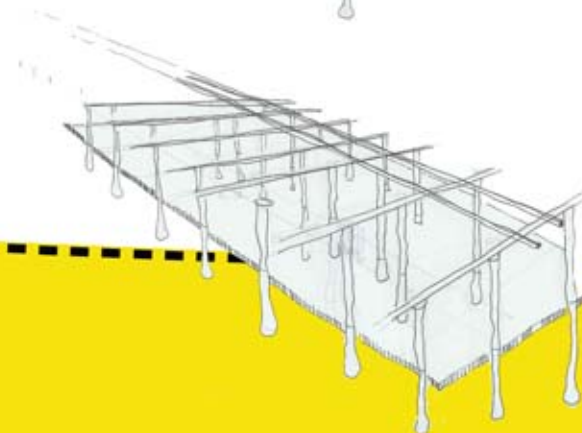

phase 3 & 4

fig. 7.5



concrete slab structure

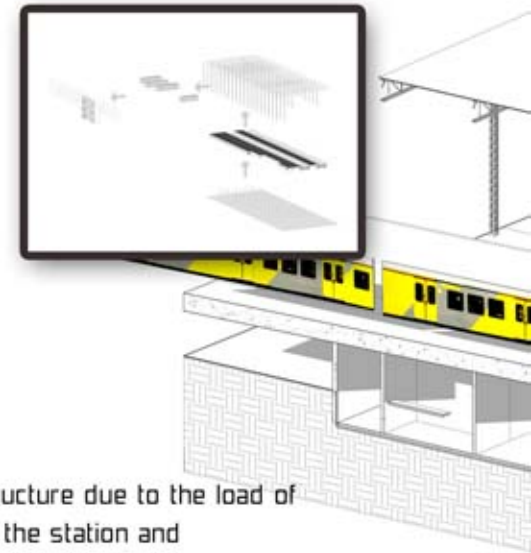

The profile of these beams are specially designed to form a foot on which the track beams rest (I-profile concrete sections which are perpendicularly placed at 700mm centres (accommodating movement of the train moving directly on the beams). These profiles 7m long precast beams (first mentioned) double up as enclosed maintenance 'trenches' where the cabling of the train is situated (fig. 7.6).

In a technical detail meeting with Metrorail (05.09.08) it was clear that precast beams are the best option to use underneath the tracks, since there is no curing waiting period (28days) necessary and quick erection is possible.

The platform area slab deals with much lower load factor and time isn't of the essence, thus a two-way coffer slab has been used in this area. This cast in-situ slab is much more adaptable to the spaces needed for staircases and lifts.

Because of the demand of such a robust structure due to the load of the train, the effect is seen in the columns in the station and commercial zone.

The 7x7m grid easily accommodates both shopping spaces between them as well as free movement of people through the building. This station and shopping area has been dropped down into the ground for maximum natural light to penetrate the building because of the now bigger openings, thus everything that belongs to the concrete structure in essence belongs to the ground, hence the platform edges becoming a grass embankment flowing into the ground.

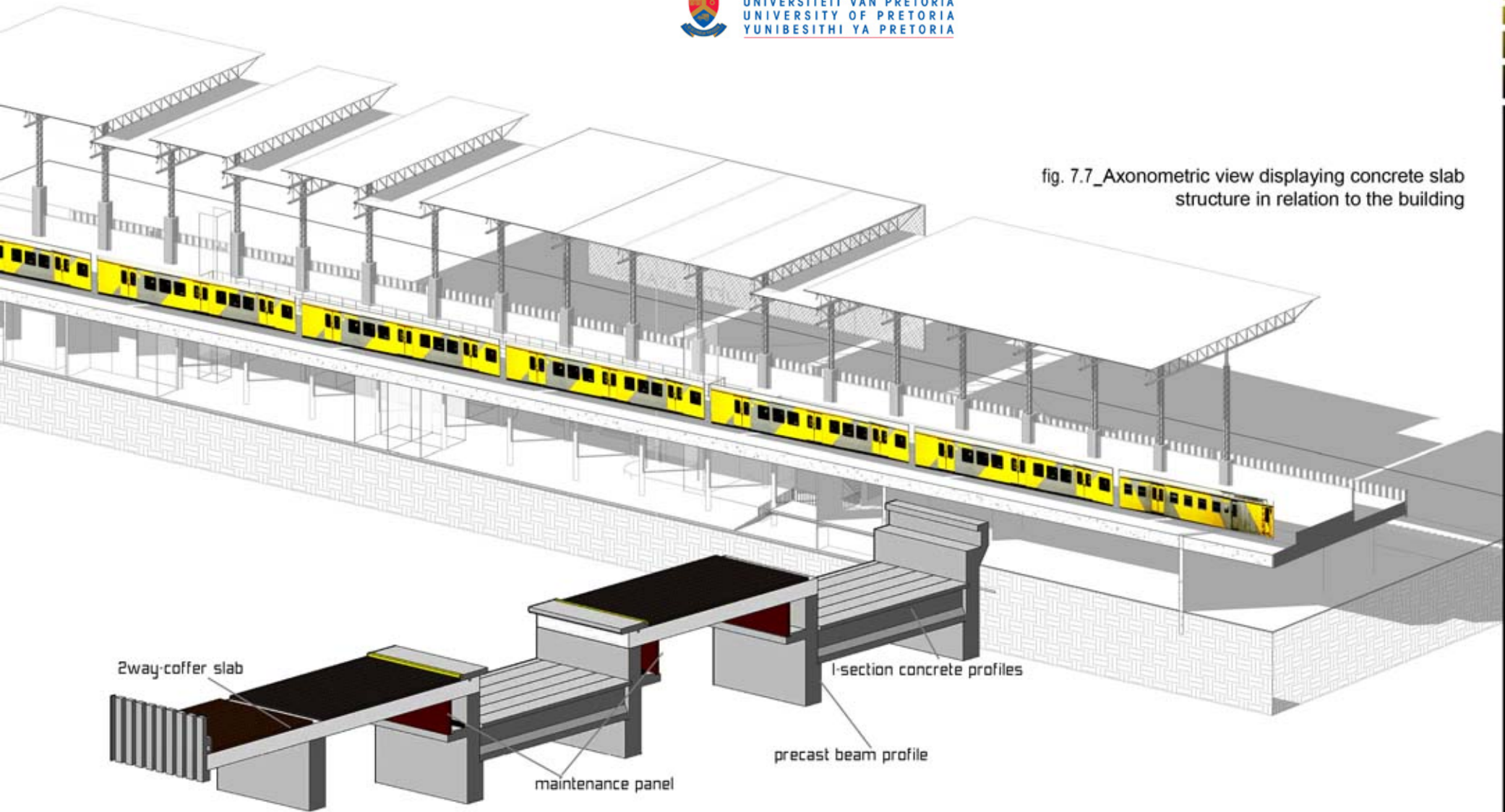
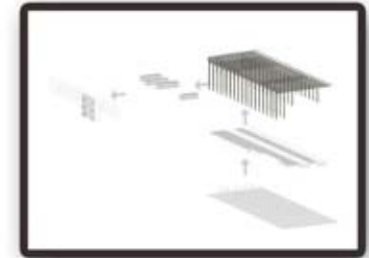
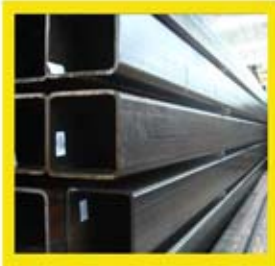

fig. 7.7_Axonometric view displaying concrete slab structure in relation to the building

fig. 7.6_Axonometric section illustrating concrete slab composition



steel structure



Unlike the concrete structure that has to carry the train's load and spread it into the ground - there is a 'lighter' side to the train, and that is the area above it - the area that belongs to the sky. A structure is needed that can span a great length (cover 2 double tracks and platforms: approx. 30m), which seems light and open at the same time. Thus a steel structure is used that reaches up into the sky (columns) embracing and welcoming the arriving trains into space (roof). This steel structure also relates on a more human scale to the daily commuter and accommodates the different movement systems coinciding at this point. The structure is easily adaptable and open for visual linkage with the surroundings. The angled braced columns on the grid represent the high tensile electrical cable system on either side of the train dating back to the very beginning of the electric train.

The roof is designed to stagger in height according to function but mainly to allow natural light into the structure (fig. 7.8). The roof slopes to the West (where the park area is) making use of the rainwater - storing it in the underground tank - and using the water for irrigation. To accommodate the low pitch of 1degree, Klip-Lok 700 roof sheeting is used. In the event of fire on the platform the structure allows quick evacuation and once under the tracks (concrete slab); commuters will be safe and protected by the high mass concrete.

Storage tank calculation:

Avg daily rainfall: 36mm

Roof m2: 2405m2
thus: $2405 \times 0.036 = 86.6\text{m}^3$

Outside floor area: 903m2
thus: $903 \times 0.036 = 32.5\text{m}^3$
= 119.1m3
minus trench area: 30m3

tank size: 89.1m3
Provide 100m3 tank

gutter calculation:
140mm2 (summer/1m2)
 $0.1\text{m} \times 0.14\text{m} = 0.014$
Roof: $1750\text{m}^2 \times 0.014 = 24.5$
thus min gutter size: 495x495

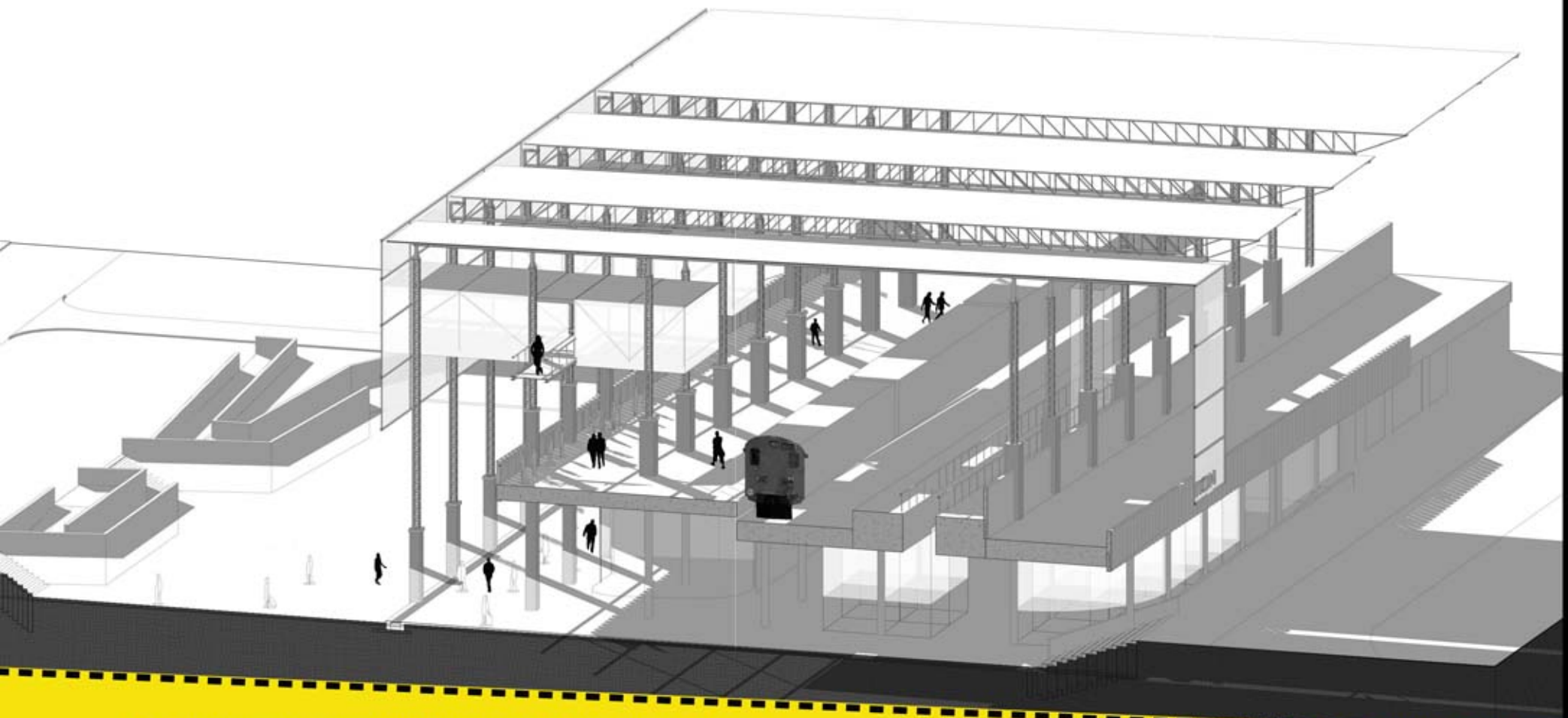

07:08

fig. 7.8_Axonometric view of the steel structure in relation to the platform

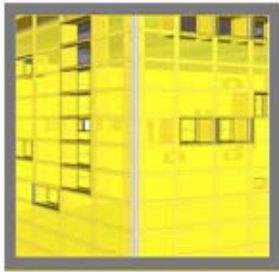

box

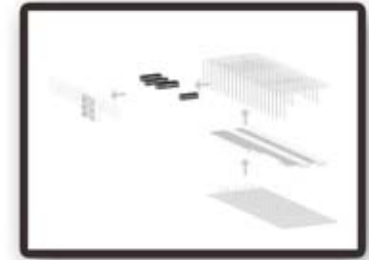

The office 'boxes' on the mezzanine level are constructed of a steel frame system clad with polycarbonate sheeting with a transparency of 70% (fig. 7.9). The choice was based on the need for these 'boxes' to glow at night. Thus becoming the trademark of Loftus Metrorail Station. The aim was to insulate these lightweight structures (while still glowing) since they face the direct SW sun. Although only a fraction of the 'boxes' are exposed to the harsh sunlight, appropriate insulation is needed.

For insulation, polystyrene balls weaved into bags and placed in the frame were used (fig. 7.14). This serves as an adequate insulator which also allows light to pass through (fig. 7.11).

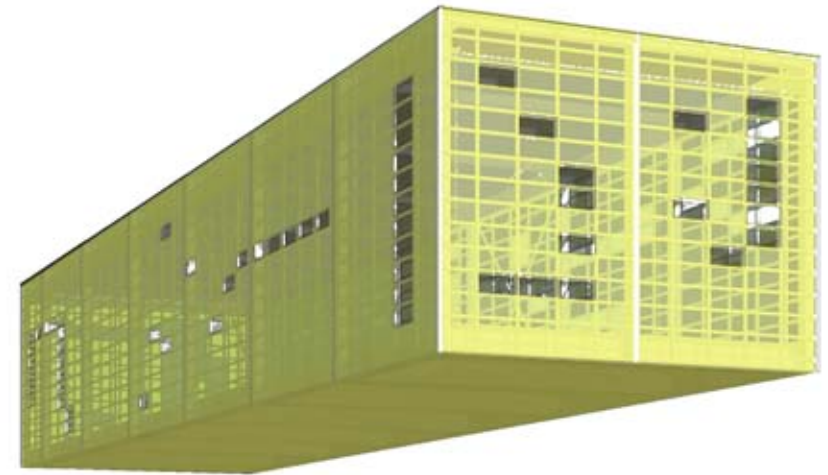

07:09

fig. 7.9_Polycarbonate sheeting



fig. 7.10_Double glazing panels

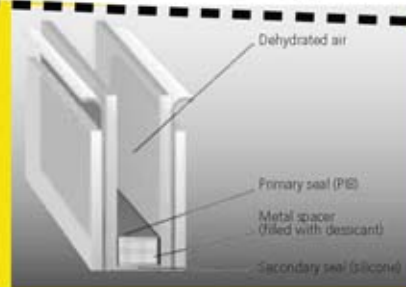

fig. 7.11_Glowing effect



fig. 7.12_Cabling suspension system



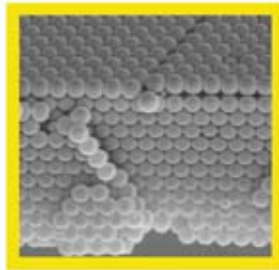

fig. 7.14_Polystyrene

insulation

The difficult placing of windows into the 'boxes' was accommodated by the intermediate frame structure holding the sheeting in place. This frame structure consists of tube steel sections at 210cm intervals and a light gauge steel section at 42cm centres with polycarbonate sheeting overlapping 1 cycle at the horizontal seams. This creates the perfect grid to insert windows in, according to the function on the inside. The window sizes are reduced as well as heat gain. Coolvue double glazing is used by Smartglass with a 12mm air gap to reduce unnecessary heat gain (fig. 7.10).

These 'boxes' are hung from a cable system welded to the steel braced column.

Clevis pins are welded to the column and a 31.75mm diameter galvanized steel wire rod (1.31kg/m, 58.1 ton strength) suspended and controlled by a turnbuckle for adjusting the cable (fig. 7.12). (Manufacturer: Anchor Industries, JHB). These cables are placed at each column at the top, the bottom and diagonally preventing movement to the sides and tilting of the cantilevers.

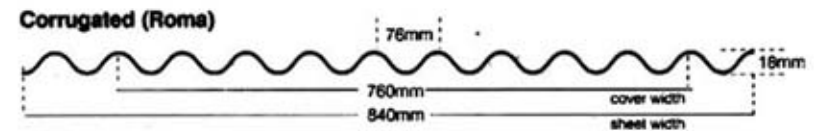

fig. 7.13_Sheeting

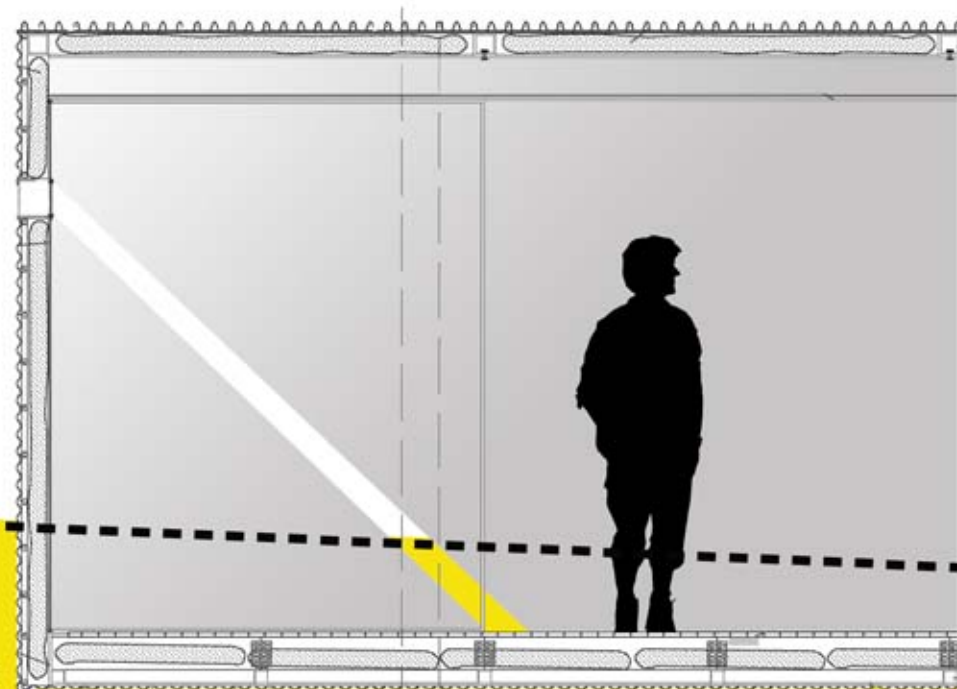
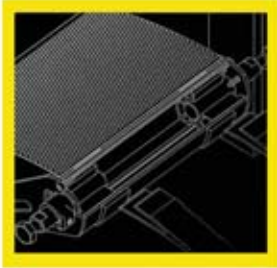

fig. 7.15_Box with insulation, illustrating internal shadow from square windows



screen

Louvered screen

Because of the predominant NE-SW orientation of the building the longest and main facade is the West facade. Therefore a shading device was designed to cover the platforms from the harsh west afternoon sun. In order for the screen to be of any use, it has been placed on an offset of 7m from the platform to completely shade the platform whilst still being open for clear visual principals.

Kool Aluminium Louvre system is used (fig. 7.17). The louvers are vertically placed and adjustable, a varied facade is achieved when the louvers are rotated in different directions according to the wind direction, giving an ever-changing screen facade while still appearing transparent and exposing the structure and function within it.

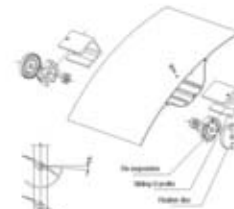
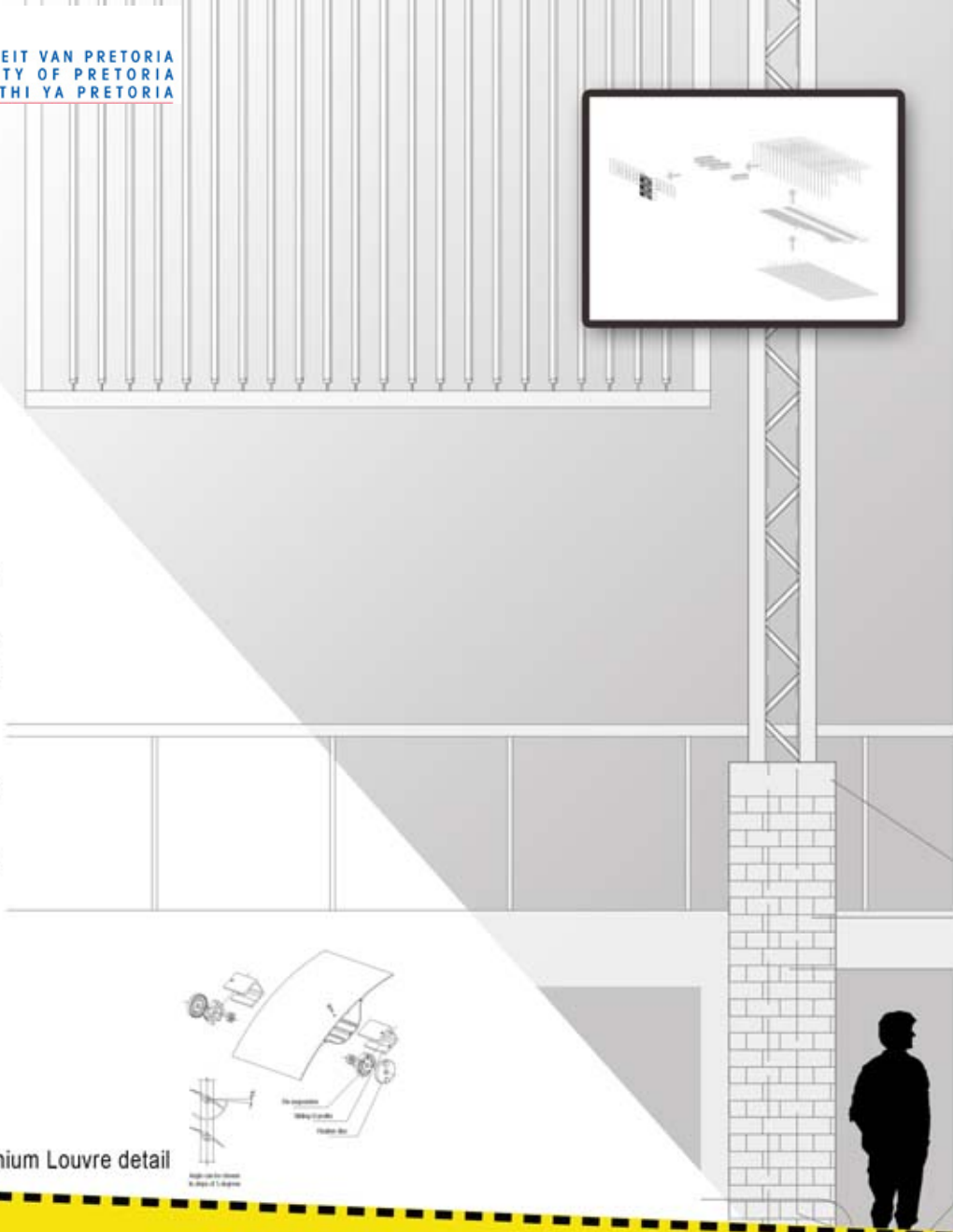
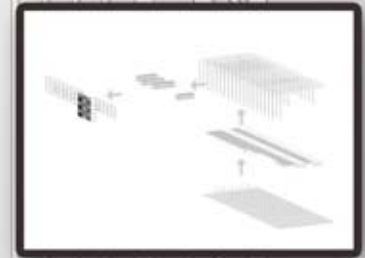

fig. 7.16_Kool Aluminium Louvre detail

gkd mediamesh



The screen is specially developed for architectural application. Constructed of stainless steel wire mesh with IT-based LED profiles, it provides a permanent, integrated and intelligent media-based facade system (fig. 7.20). The screen provides the necessary area for signage and displays required by the station and shopping centre. Live matches will be displayed when the stadium is in full capacity, hence the terraced seating in the landscape facing the screen (fig. 7.17). The screen achieves a transparency of 70% - once again exposing circulation routes placed behind the mesh. The system is water resistant, requires very little maintenance, has long life span and low power consumption.

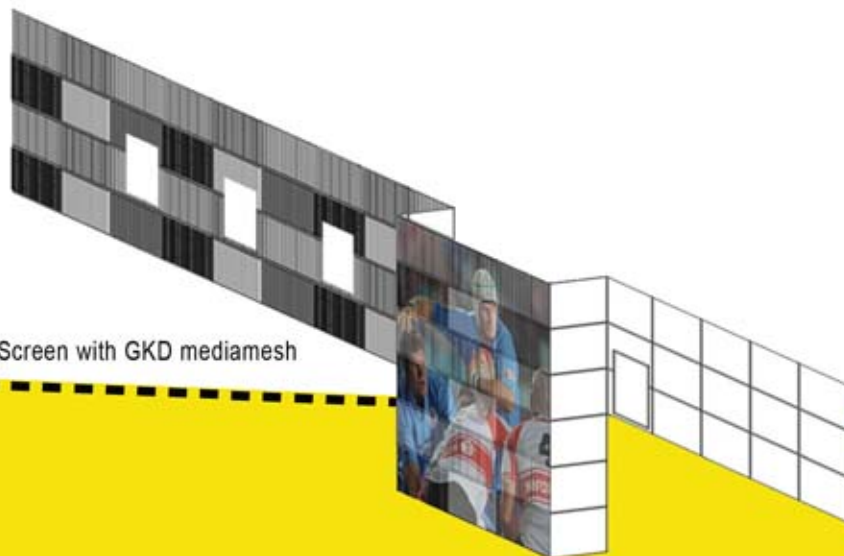

fig. 7.17_Screen with GKD mediamesh



fig. 7.18_GKD mediamesh



fig. 7.19_GKD mediamesh



fig. 7.20_Stainless steel wire mesh with LED's



circulation walkway detail

Circulation on Mezzanine level

The circulation route is constructed of steel H-sections and rest on a webbed frame system which is both bolted to a base plate and then again to the column (fig. 7.21). This structure choice is based on the structural support only available at 7m centres and needs to span the length in between (fig. 7.22).



fig. 7.21_Detail Section of walkway



fig. 7.22_Walkway detail illustrated



DESIGN
PLATFORM

↑ Exit

DESIGN CONCLUSIONS

08:00

Plans

Perspective drawings

Technical details



Design conclusions

Loftus Metrorail Station - a building conforming to functionality, ease of movement and legibility, by means of identifying the diverse range of elements and the needs of each individual.
Establishing the movement theory and maintaining it as the primary organizational force within the building.

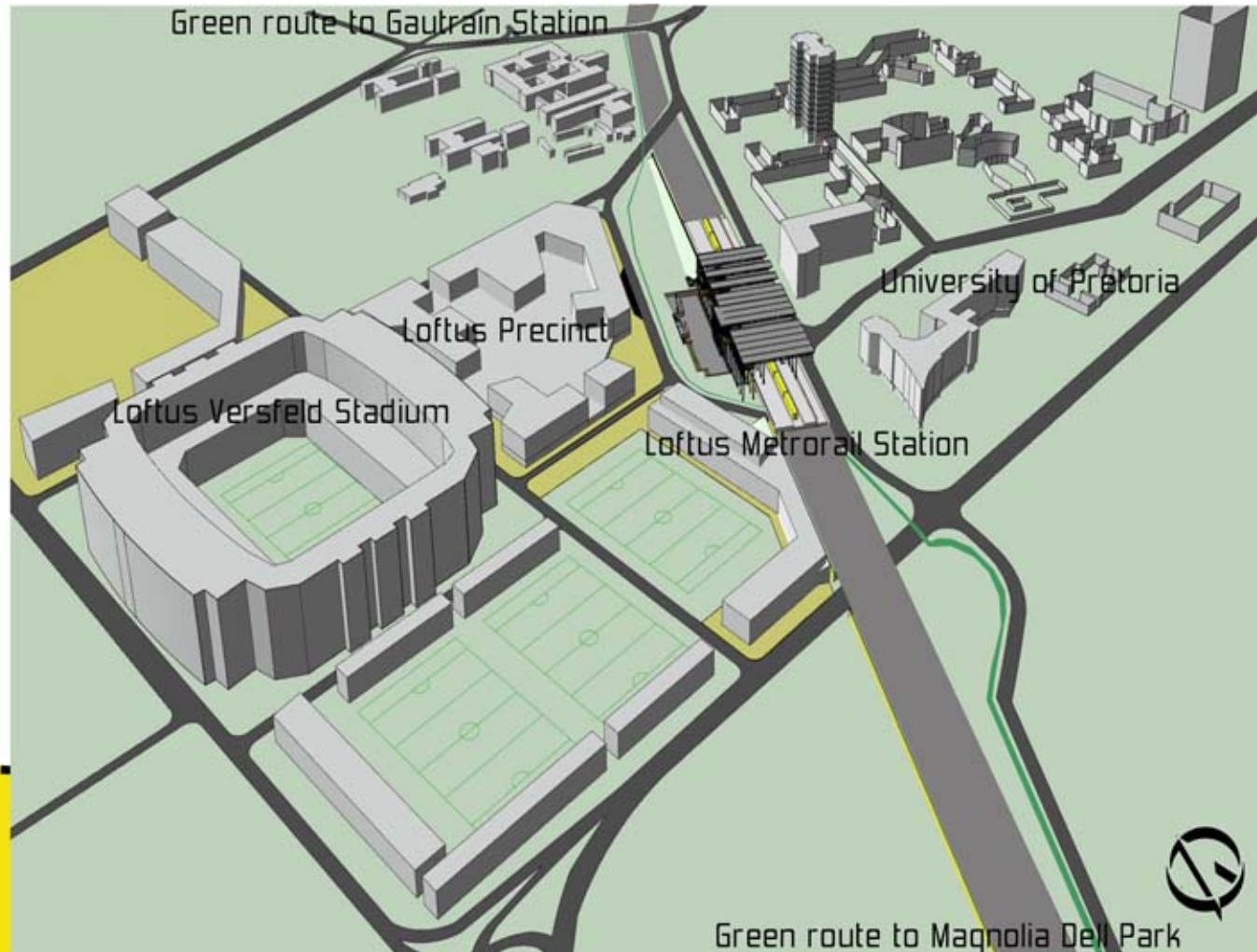

Ground level circulation

- Pedestrian through fare
- Commuters
- Shoppers
- Entrances
- Disabled
- Staff circulation



08:02

On the street level, University road, directly opposite the proposed new entrance for the University of Pretoria, is the entrance to the station building. This entrance leads straight through the building, 'hidden' underneath the tracks, towards Loftus stadium. It is this through fare that divides the 'shopping mall' and the station quarters in locality and in ownership, but at the same time feeding off one another in sharing the users.



Site movement

- Pedestrians
- Commuters
- Cyclists
- Taxis and vehicles
- Train above

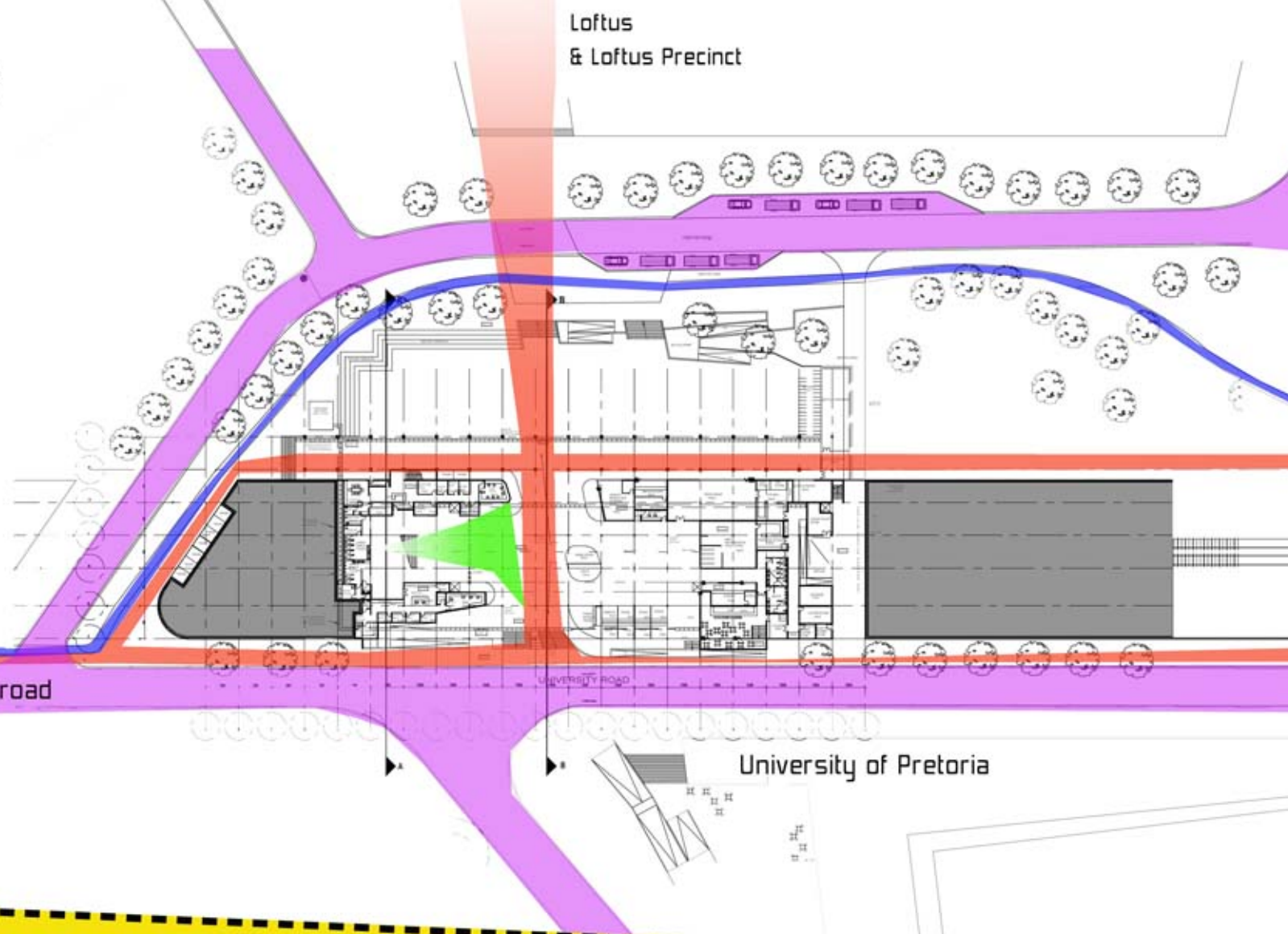

08:03

All movement systems are integrated as a whole into the site.



Ground level programme

- Bicycle rental and repair
- Restaurant and shops
- Public ablution
- Trade
- Commuter ablution
- Security Metrorail
- Admin Metrorail
- Station building
- Shopping mall



Program on ground level:

- Station building:
 - Administration
 - Security quarters
 - Public facilities
 - Circulation facilities

Shopping mall:

- Manuka Restaurant
- Keg and Leopard Pub
- Woolworths food store
- Subway
- Nashua Mobile

Odyssey Internet Café

- Kaka Smoothie bar
- ATM facility
- Security Office and Information
- Trader stalls (news stand, fresh produce, florist, craft etc)
- Public toilet facilities
- Service and deliveries.

As stipulated in the Metrorail requirements, the station and commerce facilities are separated.
Strategic placement of the program within the building to assist ease of movement and legibility.

Platform circulation

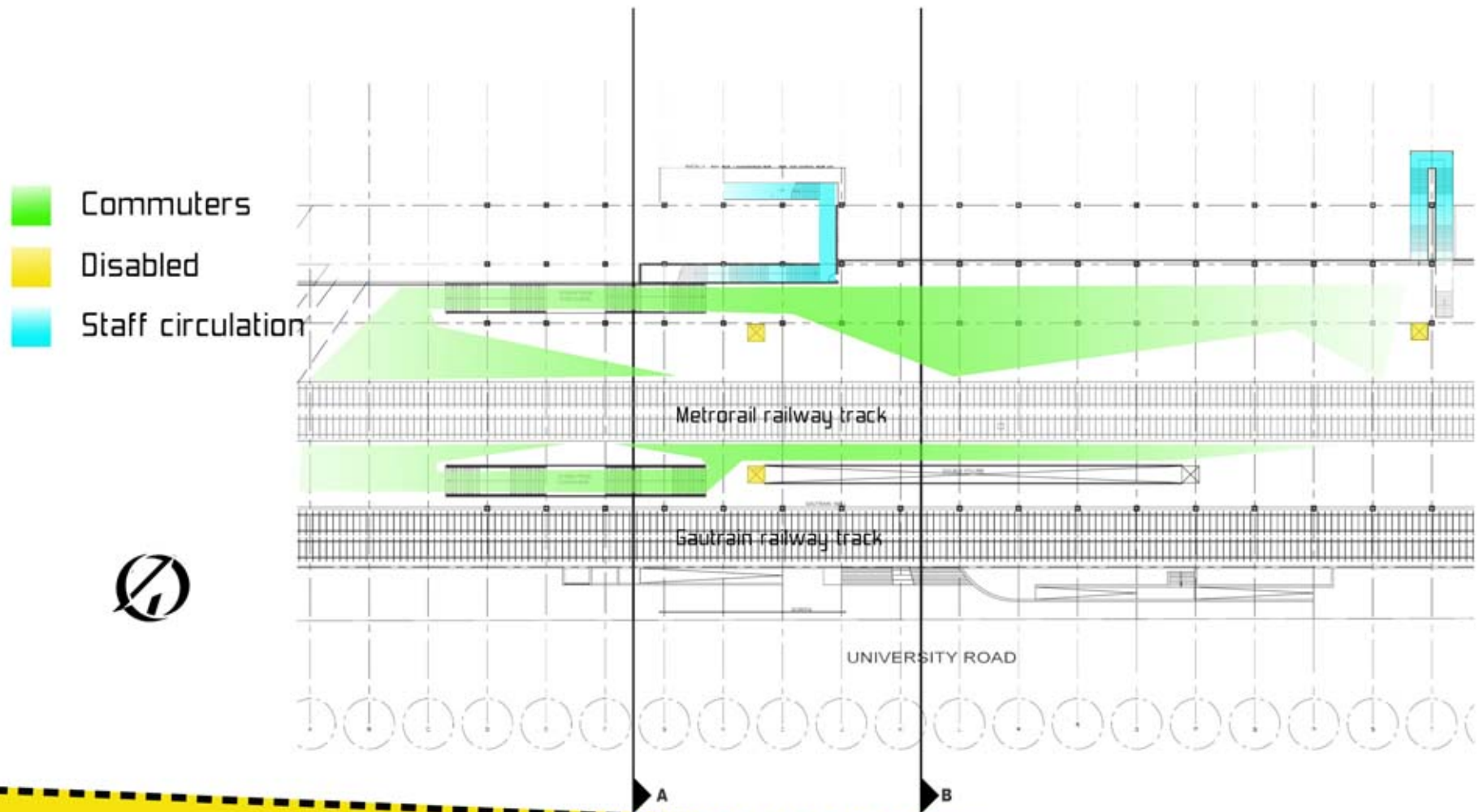

08:05

Program:
Train arrival and departure
Seating

Zones: Quick zone and Waiting zone

progression in levels = progression



Mezzanine circulation

- Staff: Shopping and Park
- Disabled
- Staff circulation
- Staff: Station

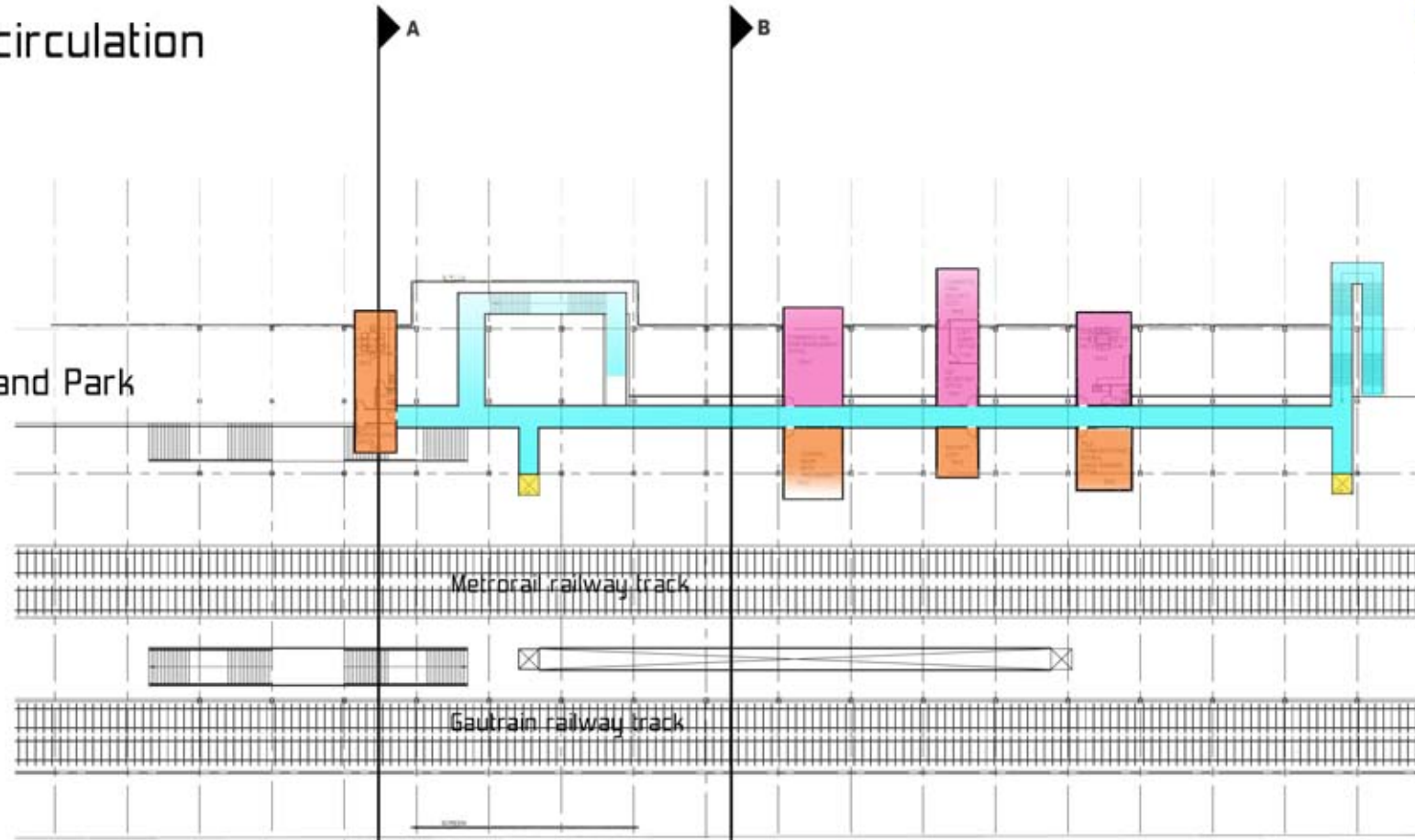

On this level the two independent entities, Metrorail and Station Shopping mall, use the same areas for administration. On the East, overlooking the platform, is the Metrorail staff program, and on the West - overlooking the park and precinct - the Station shopping administration program.

UNIVERSITY ROAD

- | | |
|----------------------------|-------------------------------------|
| Program: | |
| Metrorail Staff: | Station Shopping mall Staff: |
| Station Supervisors Office | Security office and CCTV |
| Control room | Administration offices |
| Data Processing room | Secretary office |
| Security office | Manager office |
| CCTV office | Staff room and Kitchenette |
| | Toilet facility |

- Tele-Communications room
- Cable terminal room
- Staff room and Kitchenette
- Toilet facility

08:06

from public to private



Site drainage

- Slope
- Lower roof
- Higher roof
- Box roof
- Water tank
- Trenches on ground level
- Gutter

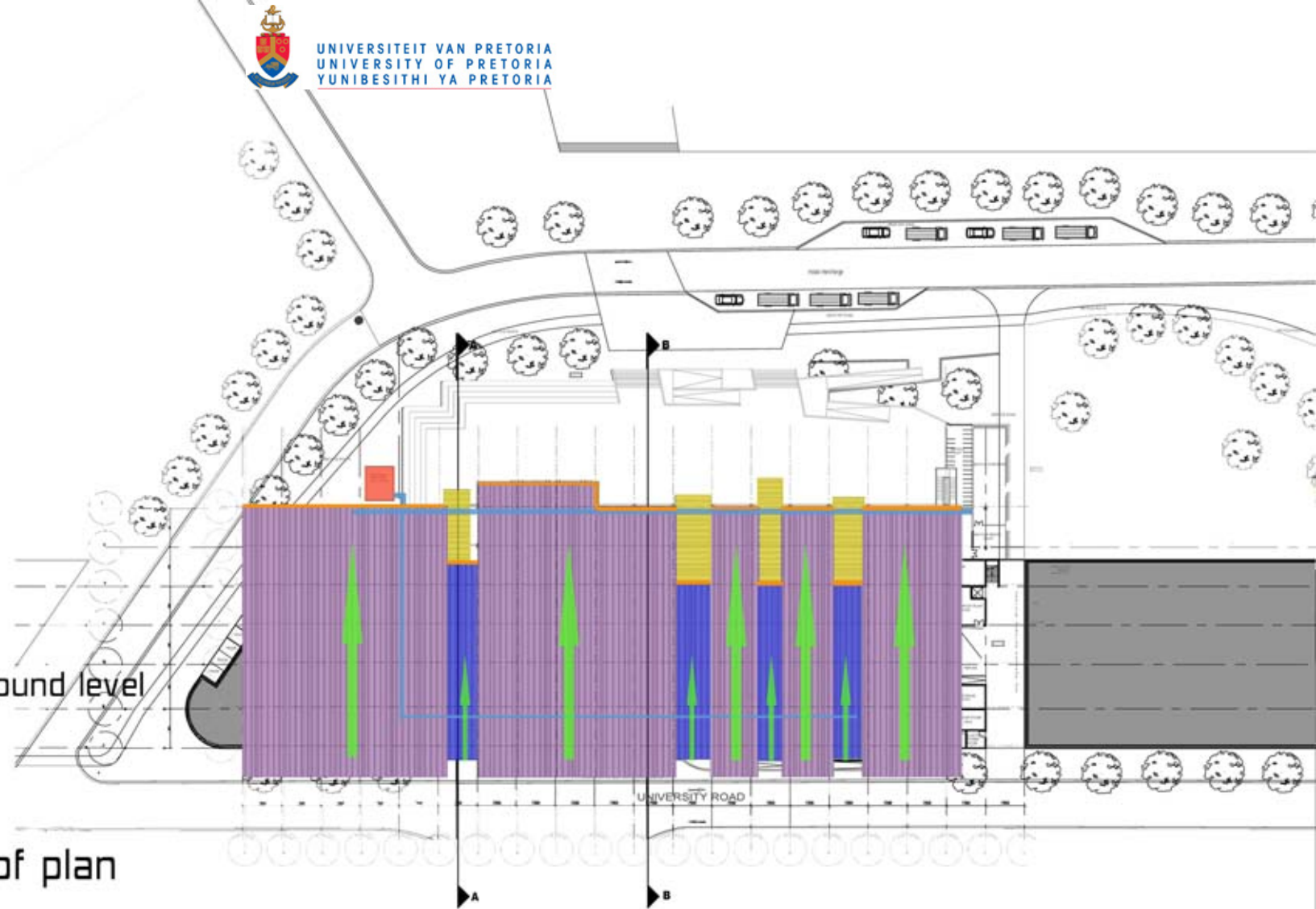

Roof plan

08:07

Rainwater and storm water is stored in an underground tank with submersible pump. A Submersible pump, with sensor - pumps abundant water into storm water channels in road reserve.

Service ducts are situated out of site in the service alleys. They are easily accessed from staff areas and prohibit any public entry. From the duct, sewerage is connected to the connection in the road reserve, the site falls to the South corner near Lynnwood Road.

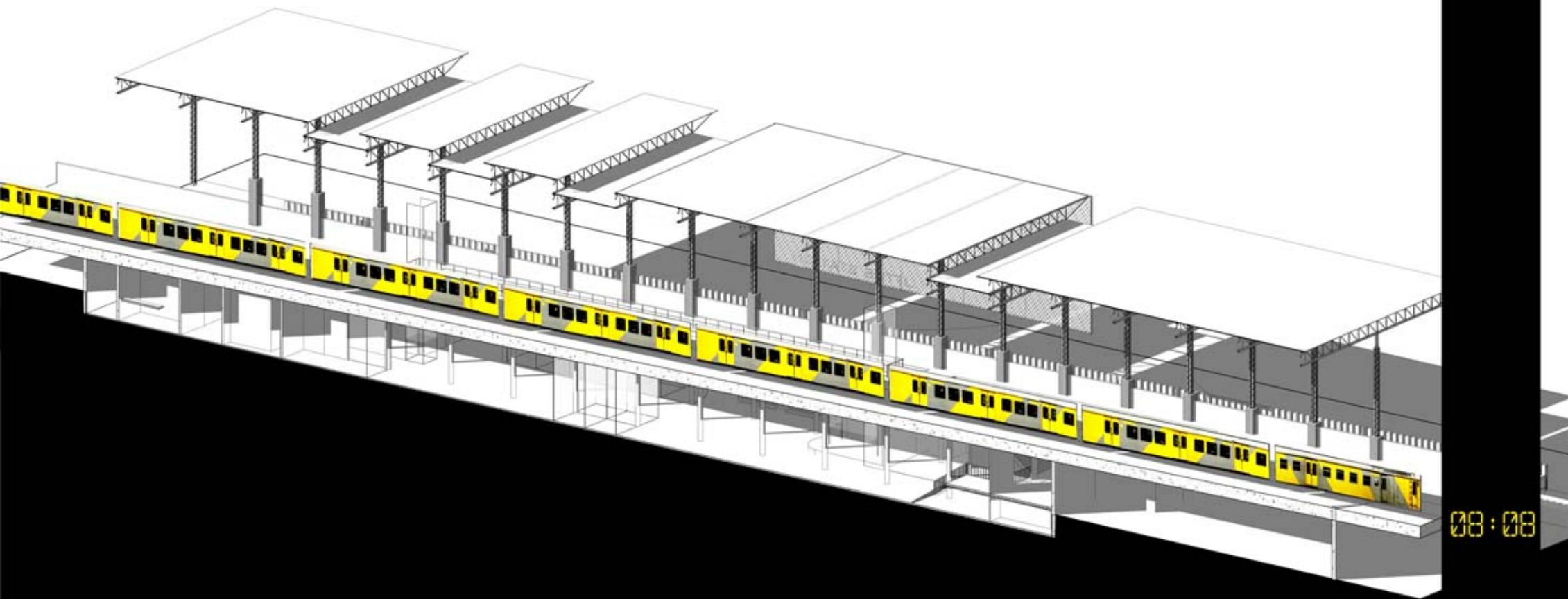

Roof Plan Axonometric displaying the staggered roof:

- allowing daylight penetration and natural ventilation.
- the shadows cast on the platform direct passengers to the focus point in the distance i.e. Loftus Versfeld Stadium



clarity of form

08:13

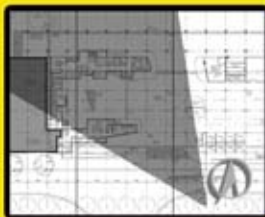

Perspective view of the main entrance into the station from University road
The display screen not only acts as shading device but more so marks the entrance to the building
Users can see Loftus Versfeld and the precinct from this point - enticing movement in that direction

BUS STATION



08:14



08:09

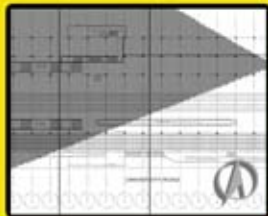

View of the platform parallel to the railway - the two passages created by the steel structure literally divides the two movement zones. The staff offices above the platform convey a human scale within the large steel structure. Once again circulation above is visible from this area



08:10

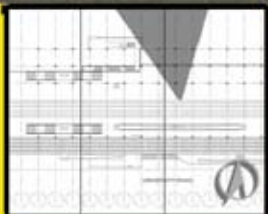

Perspective from the viewpoint of an arriving passenger - with Loftus Versfeld Stadium as focal point. Passengers can easily comprehend where to go - due to the open structure - exposing all modes of movement, from all directions possible



permeability

connectivity

08:11

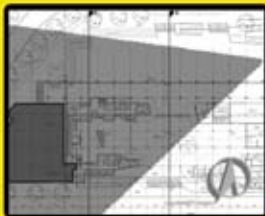

Perspective illustrating the arcade created by the steel structure reaching down and touching that 'which belongs to the ground. Accentuating the spill out space of the commerce but more importantly constantly reminding the users of activities on the higher level.



legibility



08:12

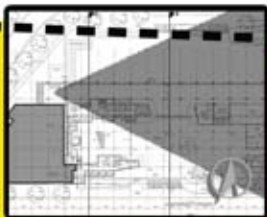

Internal view showcasing the arcade
The arcade highlights the space created instead of the mass created



08:15

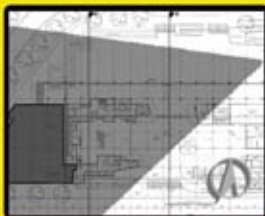

Perspective view overlooking the station building - illustrating the possibility of events that may occur in the courtyard area

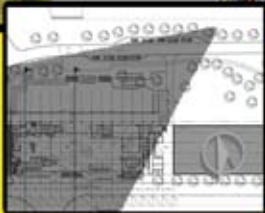

Perspective view of the modal interchange, green route (urban park) and the station building. All modes of movement is visible from this point. Thus defining this point as a node and facilitating decision making

08:17

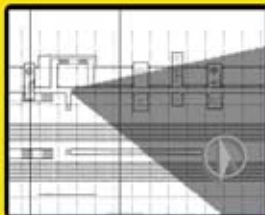

View from the Mezzanine level where staff members are accommodated
Surveillance necessary for security and station operators is ideal - a full 180 degree view of the platform is possible
Focal points in the landscape, such as the Engineering Tower building at the University of Pretoria, constantly reminds users of their surroundings.



08:18

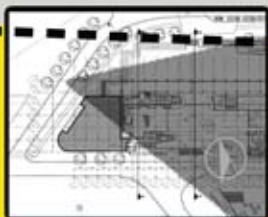

Perspective from the exit point of the slipway (under the railway)

- a clear visual of circulation routes as well as the train arriving and departing on the platform - assisting with orientation and legibility
- the GKD mediamesh provides space for interaction with the users



East Elevation



08:19



West Elevation



08:20



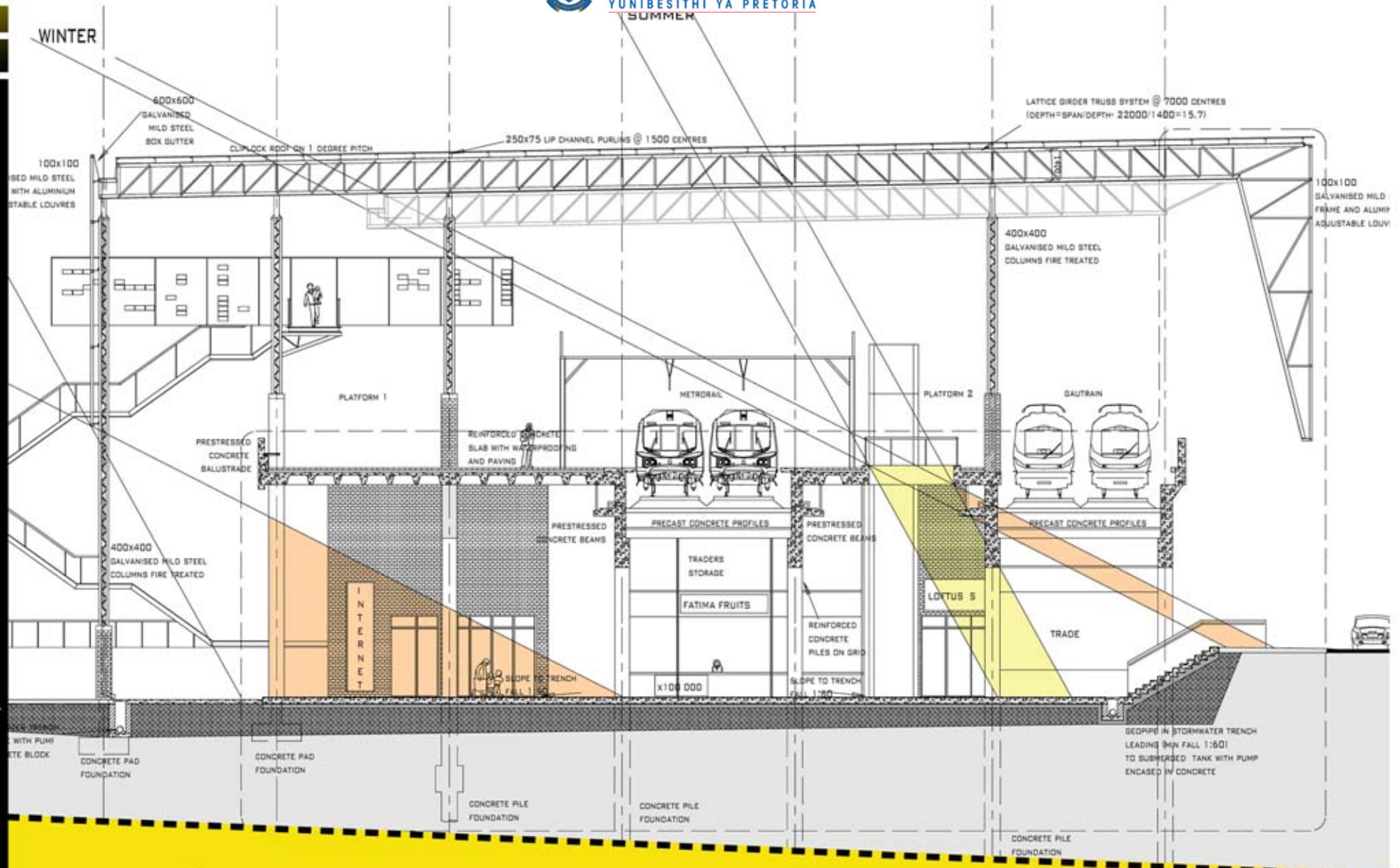

08:21



Section B-B
Scale 1:200



Column detail

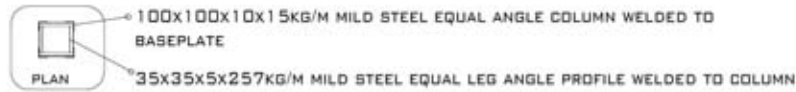

Walkway detail

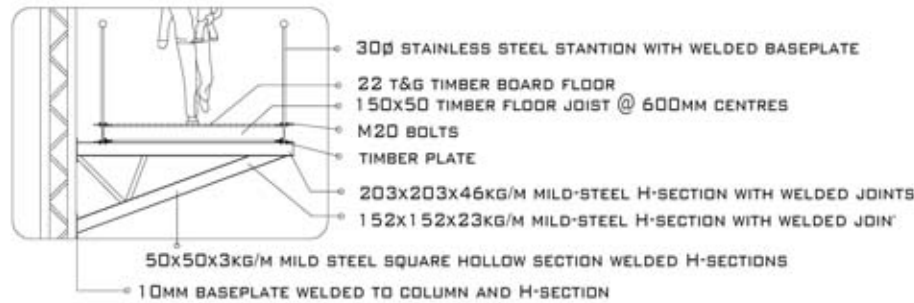

Stair and balustrade detail

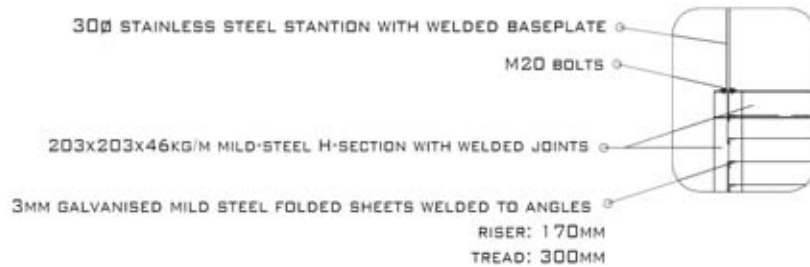

Cable system detail

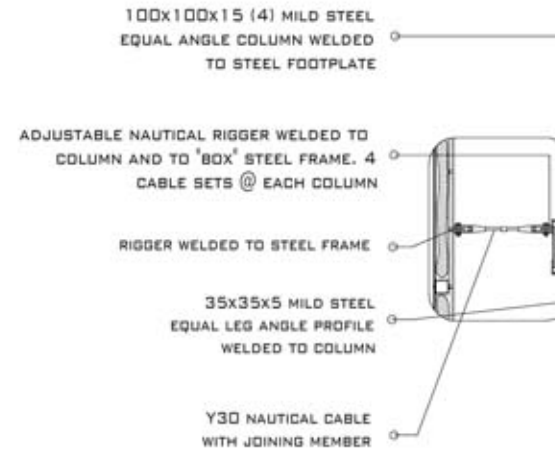

Column footing detail

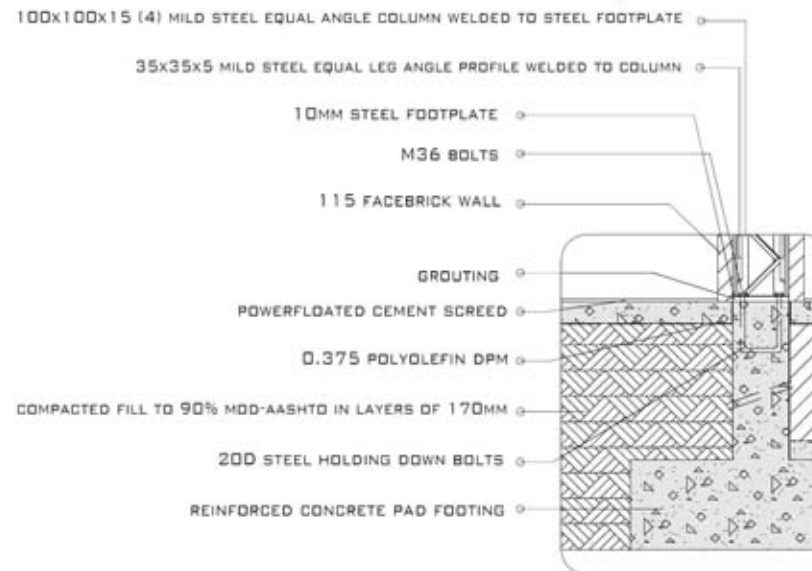

Details

Scale 1:50



STORAGE TANK CALCULATION:

AVG DAILY RAINFALL: 36MM

ROOF M2: 2405M2

THUS: $2405 \times 0.036 = 86.6\text{M}^3$

OUTSIDE FLOOR AREA: 903M2

THUS: $903 \times 0.036 = 32.5\text{M}^3$
 $= 119.1\text{M}^3$

MINUS TRENCH AREA: 30M3

TANK SIZE: 89.1M3

PROVIDE 100M3 TANK

400x400
GALVANISED MILD STEEL
COLUMNS FIRE TREATED

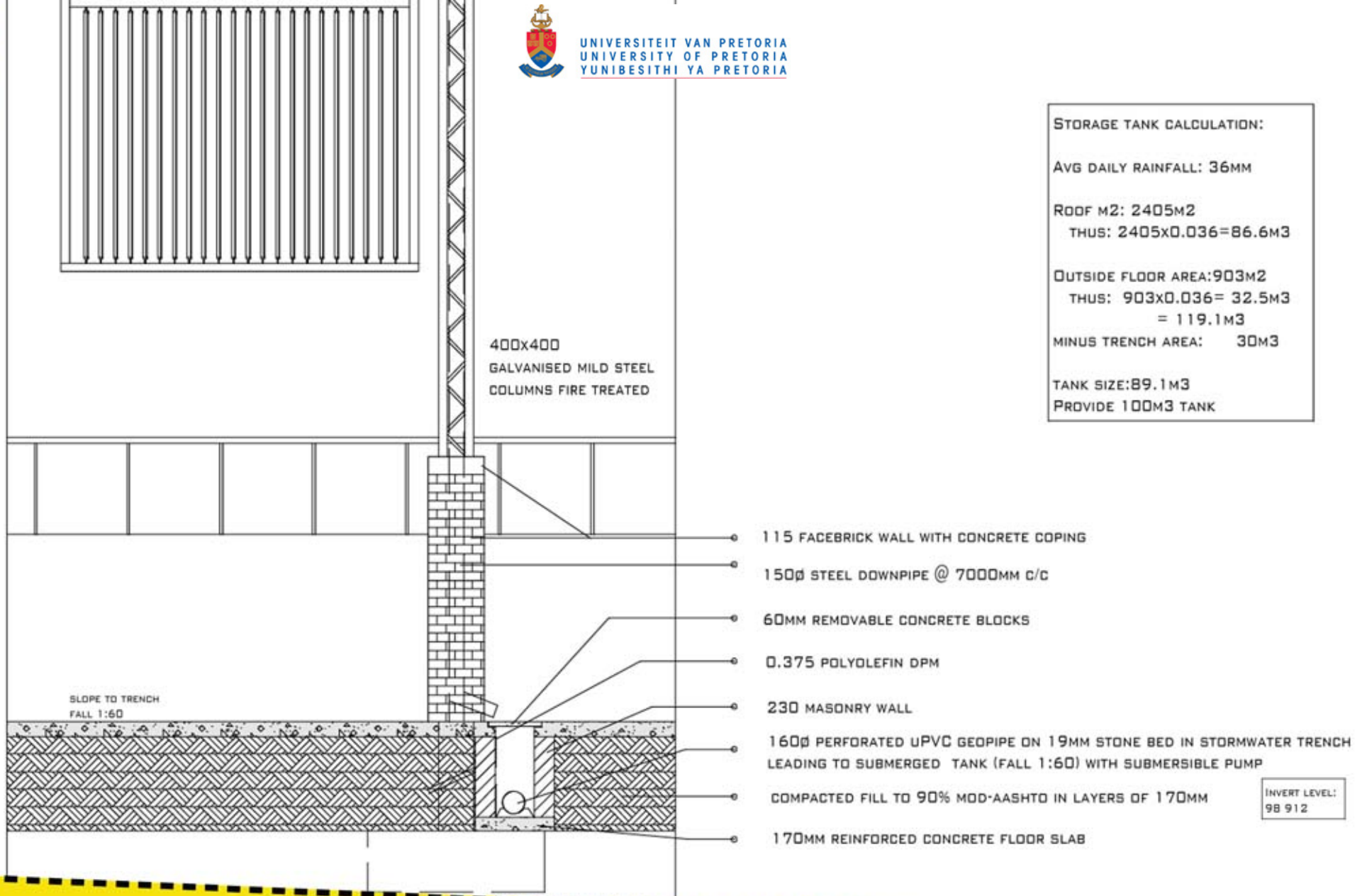

115 FACEBRICK WALL WITH CONCRETE COPING

150 ϕ STEEL DOWNPIPE @ 7000MM C/C

60MM REMOVABLE CONCRETE BLOCKS

0.375 POLYOLEFIN DPM

230 MASONRY WALL

160 ϕ PERFORATED UPVC GEOPIPE ON 19MM STONE BED IN STORMWATER TRENCH
LEADING TO SUBMERGED TANK (FALL 1:60) WITH SUBMERSIBLE PUMP

COMPACTED FILL TO 90% MOD-AASHTO IN LAYERS OF 170MM

170MM REINFORCED CONCRETE FLOOR SLAB

INVERT LEVEL:
98.912

SLOPE TO TRENCH
FALL 1:60

08:23

Skin Detail
Scale 1:100

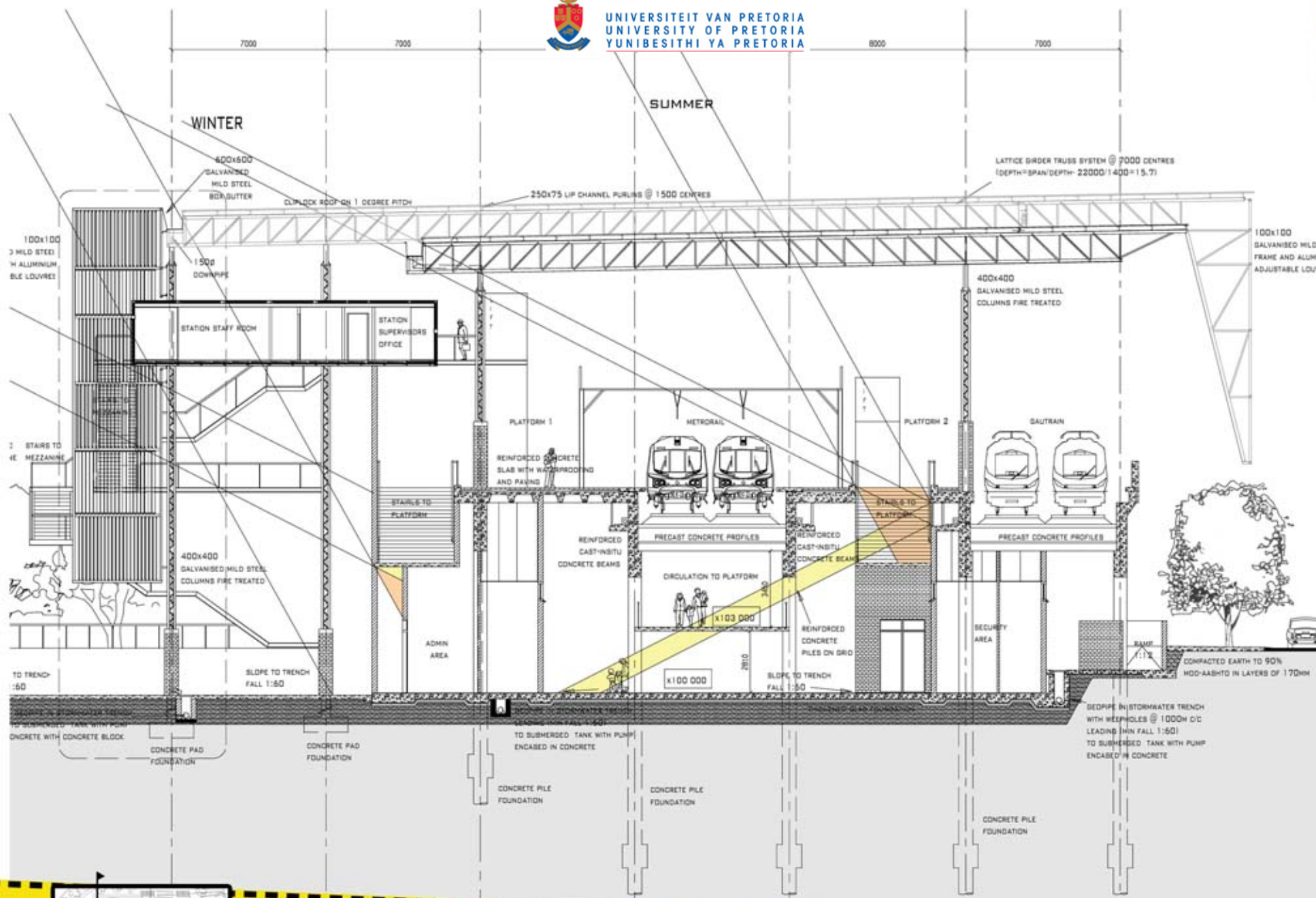

08:24



Section A-A
Scale 1:200

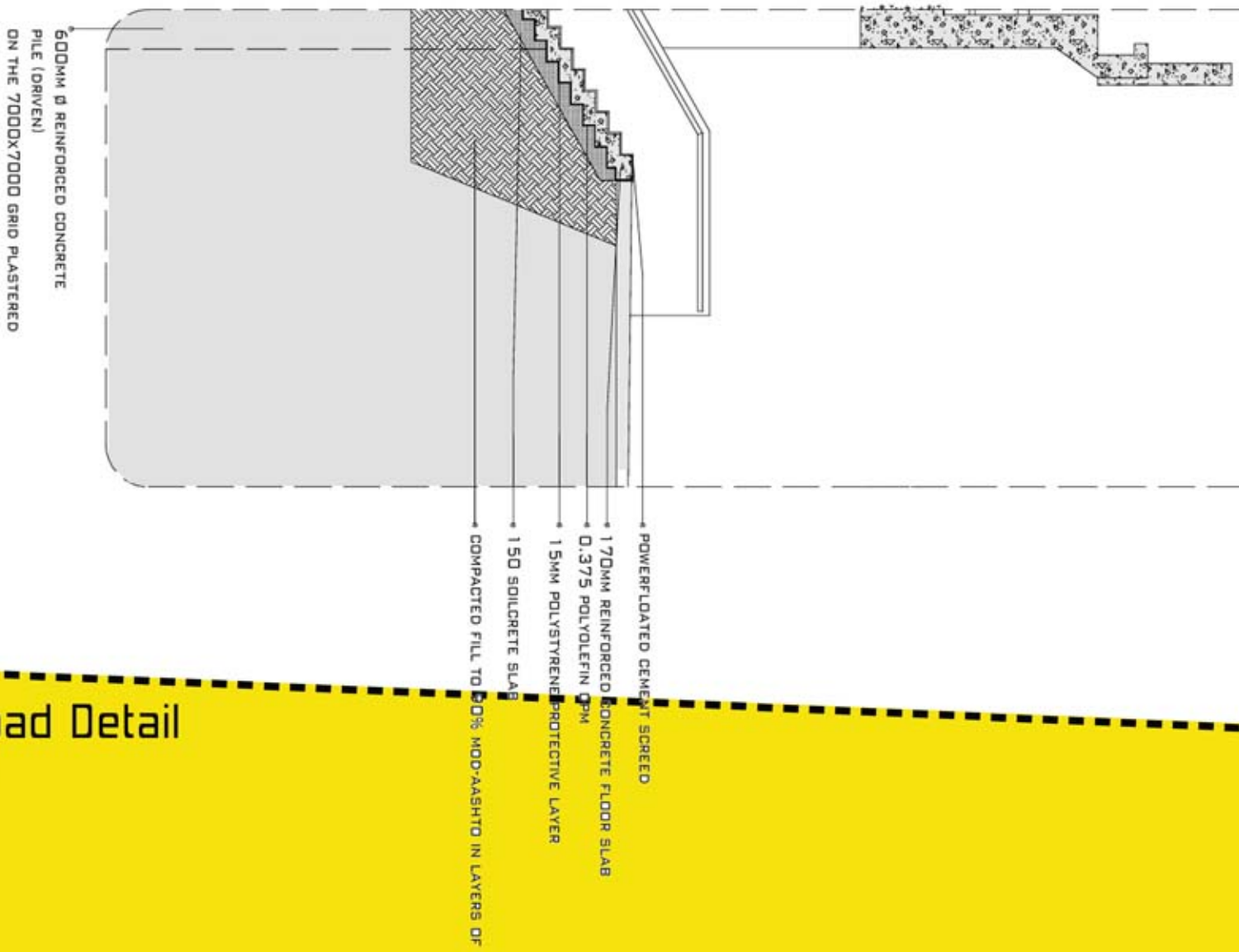

08:25

Univerity road Detail
Scale 1:100

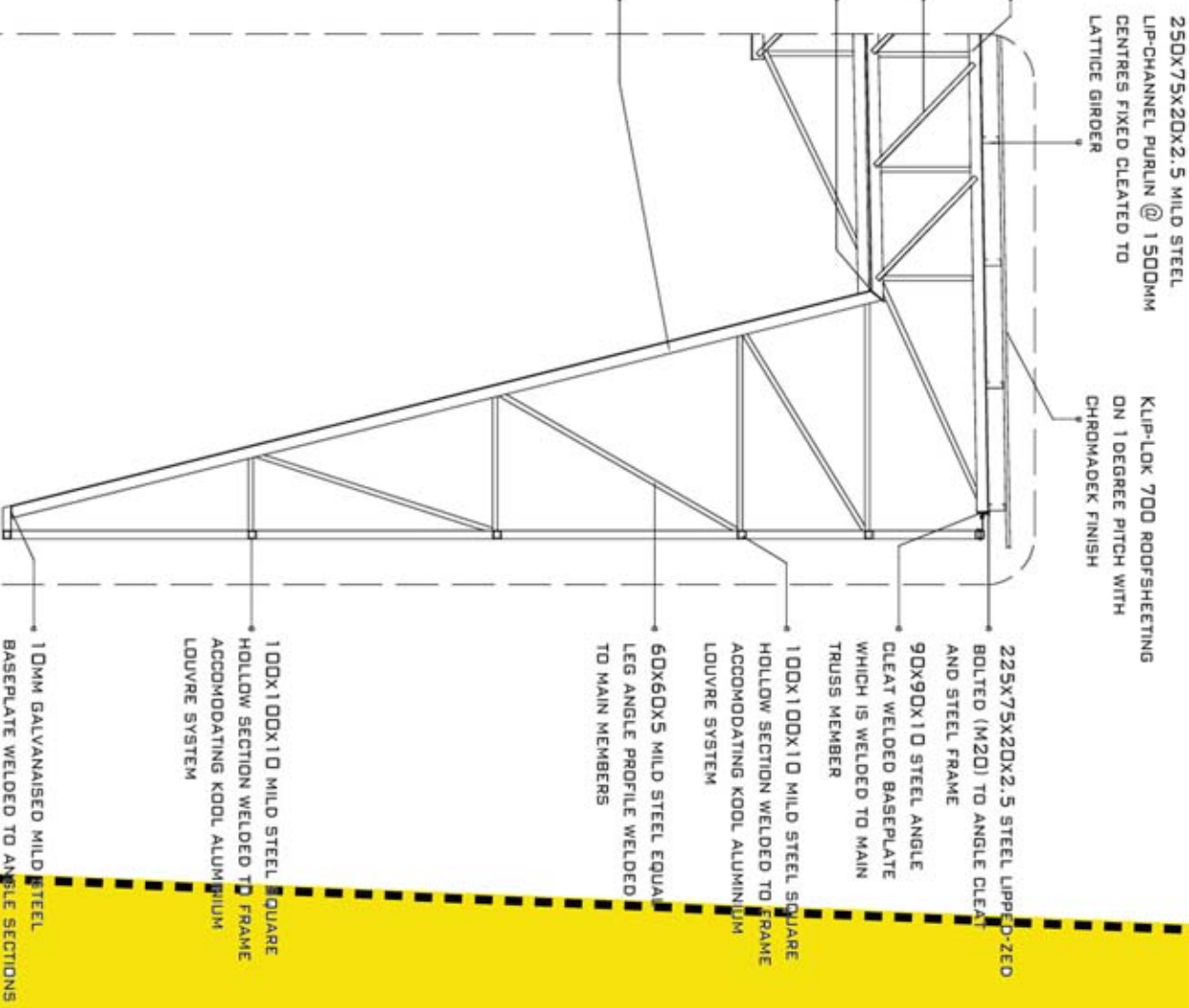
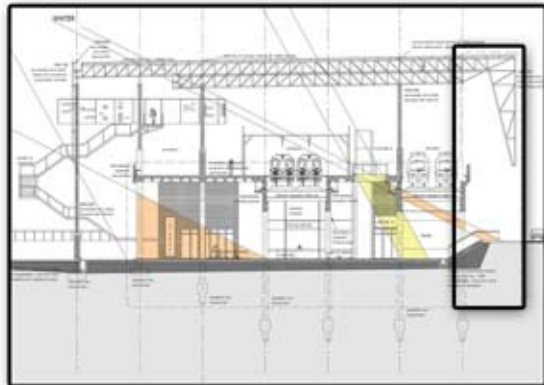

150X150X10 MILD STEEL ANGLE
PROFILES WELDED TO 10MM BASE PLATE
AND WELDED TO HORIZONTAL MEMBER
@ 7000MM C/C

10MM GALVANISED MILD STEEL
BASEPLATE WELDED TO ANGLE SECTIONS

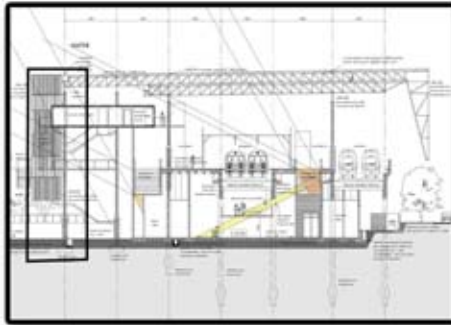

100x100x10 MILD STEEL SQUARE HOLLOW SECTION WELDED TO VERTICAL MEMBERS AND FIXED TO COLUMNS @ 7000MM CENTRES

COOL ALUMINIUM ADJUSTABLE GALVANISED STEEL ROD FIXED TO STEEL FRAME

225x75x20x2.5 STEEL LIPPED-ZED BOLTED (M20) TO ANGLE CLEAT AND STEEL FRAME

COOL ALUMINIUM AEROWING GALVANISED STEEL FIN SYSTEM

90x90x10 STEEL ANGLE CLEAT WELDED TO COLUMN

200x200x10 HOLLOW SQUARE SECTION WELDED TO COLUMN BASEPLATE AND BOLTED TO TRUSS

DRIP

TRANSLUSCENT INSULATION (EXTRUDED) POLYSTYRENE BALLS WEAVED INTO BAGS

TRANSLUSCENT (70%) CORRUGATED (MAKROLON ROMA) POLYCARBONATE SHEETING OVERLAPPING ONE CYCLE AT HORIZONTAL SEAMS AND FIXED WITH SCREWS TO FRAME

STEEL WINDOW FRAME WELDED TO STRUCTURAL FRAME

DOUBLE GLAZING OPENING SECTION

6MM FROSTED SAFETY GLASS

240x85x33KG/M MILD STEEL CHANNEL FIXED TO FRAME STRUCTURE WITH M20 BOLTS

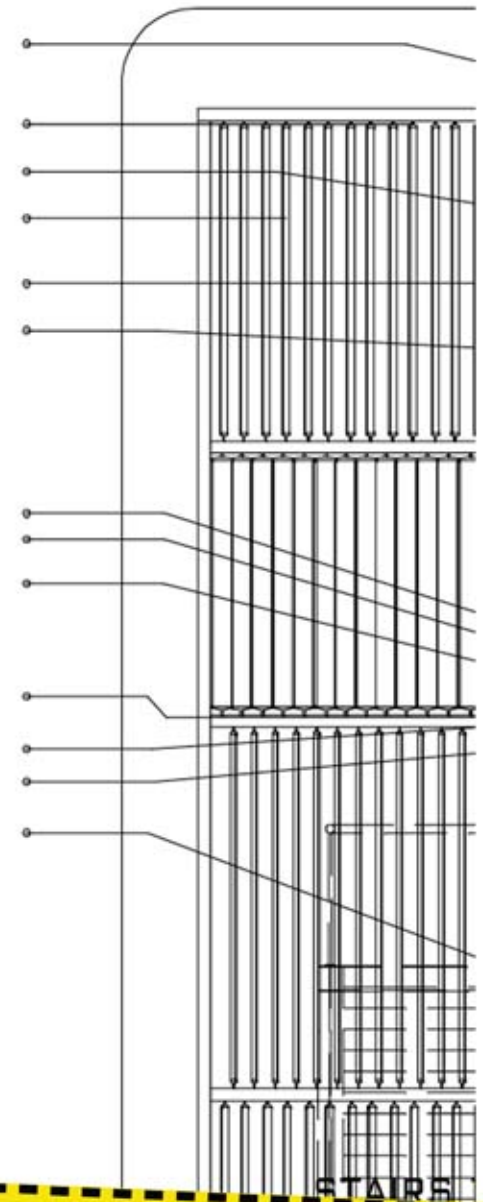

STAIRS

08:27

Facade Detail

Scale 1:100



GUTTER CALCULATION:
140MM² (SUMMER/1M²)
0.1M x 0.14M=0.014
ROOF: 1750M² x 0.014=24.5
THUS MIN GUTTER SIZE: 495x495

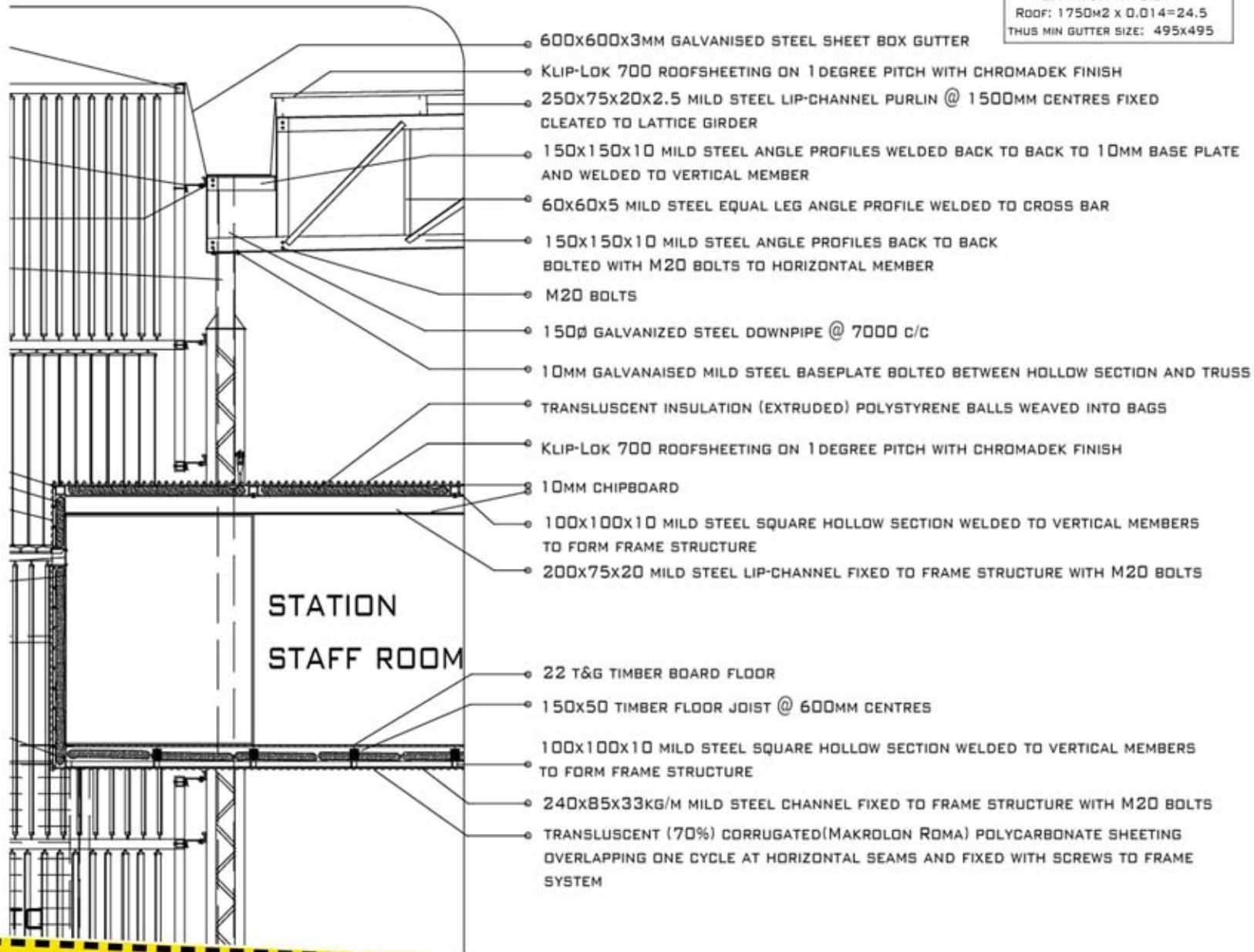

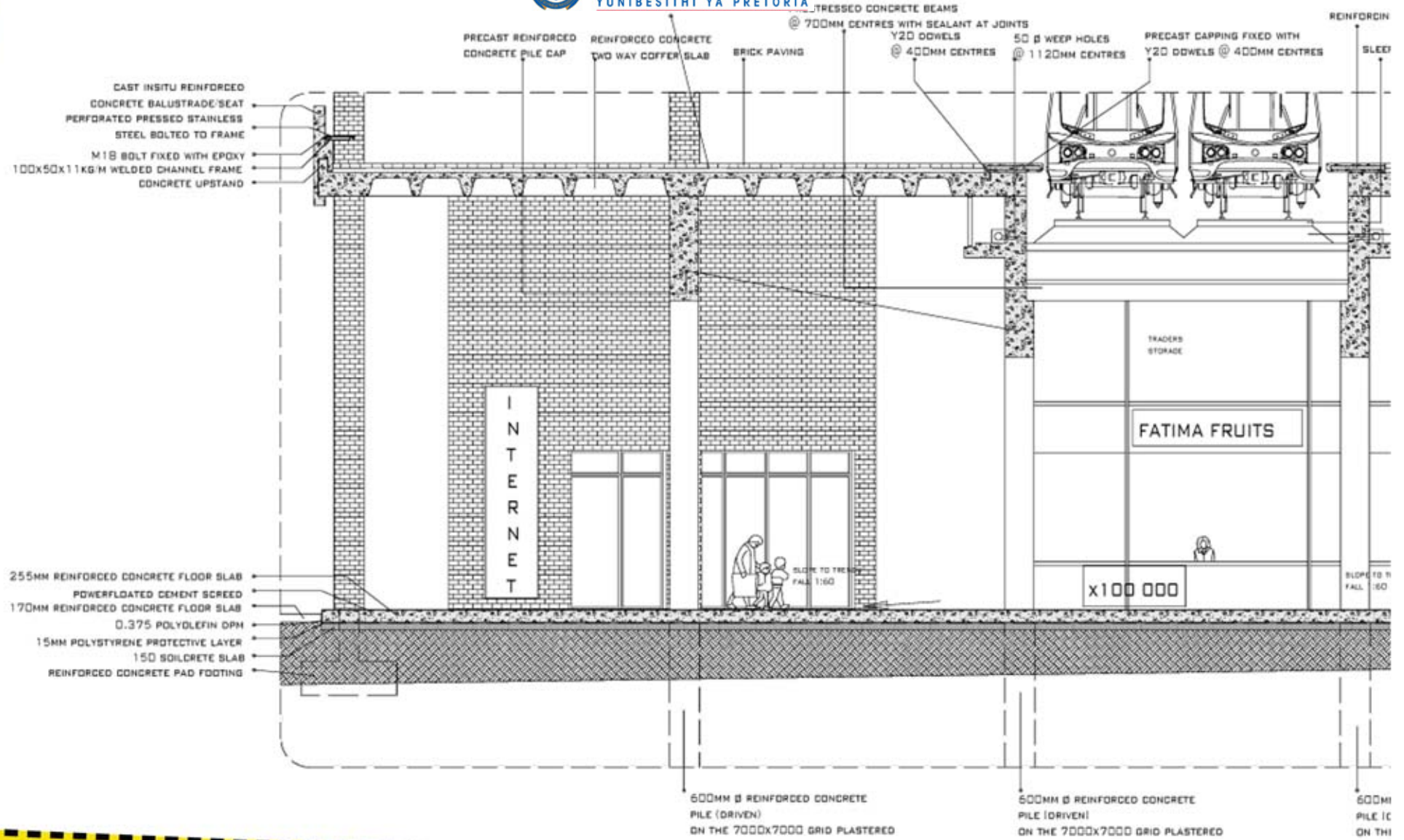

08:29

Sub structure Detail

Scale 1:100

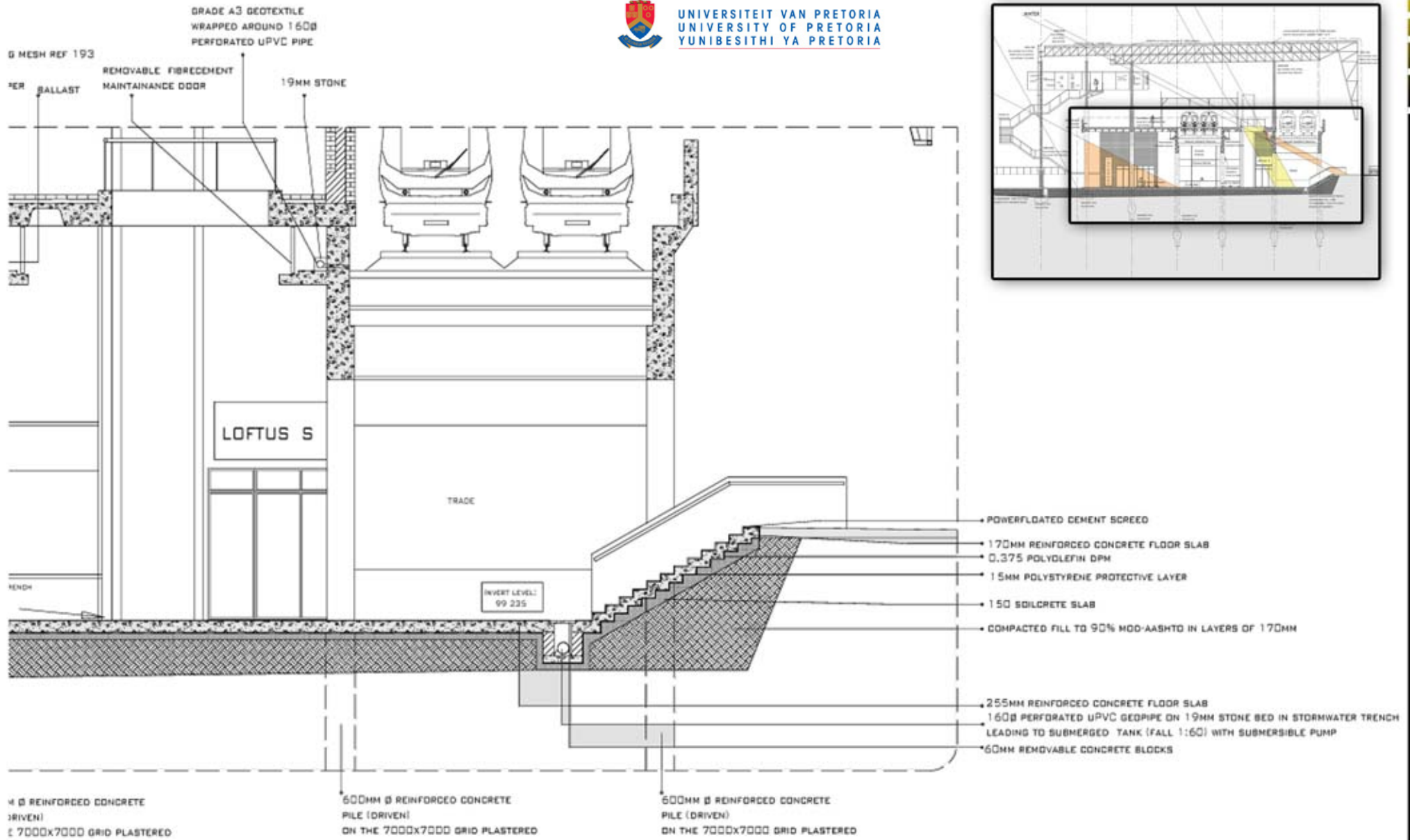



SOURCES
PLATFORM



Exit

LIST OF SOURCES 09:00



List of Sources

Books

1. ALEXANDER, C., 1977. *A Pattern Language*. New York: Oxford University Press
2. BACON, E., 1967. *Design of Cities*. London: Thames and Hudson
3. BALLARD BELL, V., 2006. *Materials for Architectural Design*. London: Laurence King Publishers Ltd
4. BENTLEY, I. et al., 1985. *Responsive Environments: a Manual for Designers*. London: Architectural Press
5. BERTOLINI, L., 1998. *Cities on Rails*. London: Routledge
6. BROADBENT, G., 1990. *Emerging Concepts in Urban Space Design*. London: Van Nortstrand Reinhold
7. CERVER, F., 2003. *The World of Contemporary Architecture*. Germany: Konemann
8. CHAPMAN, T., 2007. *Architecture 07. The Guide to the RIBA Awards*. London: Meryll
9. DEWAR, D., 1997. In H. Tillman, ed. *Housing Generator. Integration or Fragmentation*. Rotterdam: NAI Publishers
10. DEWAR, D & UYTENBOOGAARDT, R., 1991. *South African Cities – A Manifesto for Change*. Cape Town: UPRU
11. JACOBS, J., 1966. *The Life and Death of Great American Cities*. New York: Harmondsworth
12. KRUGER, T. et al., 2001. *Designing for Safer Places, a Manual for Crime Prevention through Planning and Design*. Pretoria: CSIR & SAPS
13. LAUBSCHER, H.P., 1992. *Die Verhaal van Hatfield*. Pretoria: Pretoria Historica Publishers
14. LYNCH, K., 1960. *The Image of the City*. Cambridge: M.I.T Press
15. NORBERG-SCHULZ, C., 1980. *Genius Loci – Towards a Phenomenology in Architecture*. London: Academy Editions.
16. SHITTICH, C & BIRKHAUSER, U., 2006. *In Detail-Building Skins*. Germany: Publishers for Architecture
17. TRANCIK, R., 1986. *Finding Lost Space - Theories of Urban Design*. New York: Van Nortstrand Reinhold

Articles

1. DOBSEN, R & LEES, J. 2008. Intuitive process(es) towards responsive urban architecture. *Architecture*, January/February, p24
2. KHAN, A., 1995. Construction knowledge of the urban site. *ACSA European Conference*. Lisbon: s.n.
3. WILLIAMS, H.A., 1994. End of the line. *Architectural Record*, June 1994, vol. 94, no.6, p90-7
4. WOODE, D ed. 2003. Mutualpark West Campus. *Architect and Builder*, January/February, p24-33.



Websites

1. CABA. 2003. The councillor's guide to urban design. [online] 1 Nov., 2003. Available at: <http://www.cabe.org.uk/default.aspx?contentitemid=1069> [accessed 21 March 2008]
2. City of Tshwane - Streetscape design guidelines., 2007. [internet]. Available at: http://www.tshwane.gov.za/documents/Streetscape_Design_Guidelines.pdf [accessed 25 August 2008]
3. Kool Aluminium Brochure., 200-. [internet] Available at: <http://www1.hunterdouglascontract.com/HDWeb/Cultures/en/Products/SolarControl/SunLouvers/Aerofins/Aerowing/> [Accessed 12 September 2008]
4. Mediamesh Brochure., 200-. [internet] Available at: http://www.medienfassade.com/fileadmin/media/pdf/ag4_Mediamesh_Illumesh_en.pdf [Accessed 4 October 2008]
5. Metrorail Priority workshop., 2006. [internet] Available at: http://www.simbaproject.org/download/south_africa/Rail%20Passenger%20Transport%20-%20SARCC.pdf [Accessed 11 August 2008]
6. Smartglass Coolvue Brochure., 2008. [internet] Available at: <http://www.smartglass.co.za-performance/data/insulvue/double-glazed> [Accessed 22 September]
7. South African Commuter Corporation., 200-. [internet] Available at: www.sarcc.co.za [Accessed 26 March 2008]

Personal Communication

1. Bercher, R (Chief Engineering Technician, Metrorail)., 2008. [interview discussing technical details of train](Personal communication, 15 May 2008)
2. Dupisane, S (Chief Horticulturist, Tshwane Municipality)., 2008. [interview discussing Municipal depot and possible relocation](Personal communication, 3 May 2008)
3. Pienaar, M. (HolmJordaan Architects)., 2008. [Retrieval of Metrorail design guidelines/requirements](Personal communication 11 August 2008)
4. Pierce, M (Girls High School Administration)., 2008. [Interview discussing Girls High School](Personal communication, 21 April 2008)
5. Taute, J (Area Manager, Metrorail)., 2008. [Interview discussing Metrorail in general] (Personal communication, 7 May 2008)