

CHAPTER 2 : THE LIVE CAPTURING OF FREE RANGING LEOPARDS.

INTRODUCTION

The live capturing of elusive free ranging carnivores has over the years proved to be very time consuming and the effort in most cases enormous. Such capture operations are therefore mostly conducted for the purpose of research projects, the removing of problem animals from livestock depredation areas and for harvesting furbearers.

Failure to capture problem animals promptly and effectively without damaging non-target animals, is the most crucial component of problem animal management (Beason 1974). Many research projects have also been terminated due to problems associated with the capture of study animals.

Numerous techniques have been employed for different carnivores in diverse habitat types and conditions. These ranged from direct darting of spotted hyaenas (Crocuta crocuta) from vehicles (Henschel 1986) and coyotes (Canis latrans) from helicopters (Baer, Severson & Linhart 1978) to capturing leopards in box traps (Norton & Lawson 1985). Steel-jawed traps (gintraps) have been successfully used for the live capturing of many canids, e.g. wolves, Canis lupus (Kolenosky & Johnston 1967), dingos Canis familiaris dingo (Green 1976) and black-backed jackals, Canis mesomelas (Rowe-Rowe & Green 1981). Englund (1982) captured red foxes (Vulpes vulpes) successfully with plastic foot snares.

On occasion trained tamed animals have been used to chase target animals into trees or holes. Tigers (Panthera tigris) have been chased into trees with the aid of Asiatic elephants (Elephas maximus) and darted. Trained dogs were used for mountain lions, Felis concolor missoulensis, (Hornocker 1970). In many instances adaptations and modifications of these techniques are necessary to realise the objectives in different situations.

Leopards have been captured live using boxtraps in Kenya, Tsavo National Park (Hamilton 1981), and in the Lowveld, Kruger National Park (Hornocker & Baily 1986). In areas outside conservation areas the situation is somewhat different. Due to persecution, leopards are much more wary and elusive, and success with conventional boxtraps is rare (Norton & Lawson 1985). This is also the scenario in the Waterberg, where capturing of especially problem leopards with boxtraps is virtually impossible.

OBJECTIVES

The objective of this chapter is to present information on successful capture techniques developed for the capturing of leopards in the Waterberg. This information is not only relevant for future research projects, whereby live capturing of individuals is essential but also crucial for the fast and effective elimination of problem leopards.

METHODS

With advice received from numerous expert farmers and TFA Officials, together with extensive efforts launched in the Waterberg, specific technique modifications for specific situations were developed and tested.

The following techniques were involved:

Box or Cage traps

- (i) Single door walk-in box trap
- (ii) Double door walk-in box trap

Steel jawed traps :

- (i) Jump trap
- (ii) Horizontal double coil spring steel trap.

Single door walk-in box trap :

This trap was made from a metal frame measuring 2,0m x 0,9m x 0,9m and covered with 6mm iron rods to form a mesh of 80mm x 80mm. The sliding door was activated by a 1,5mm steel cable, fastened by means of a pulley system to the bait. An alternative approach was to use an 800mm x 300mm footplate in front of the bait which triggered the pulley system as soon as the animal stepped on the plate.

Box traps were hidden in relative dense bush under a low canopy, accessible by a 4x4 vehicle. The cage was only partially covered with dry branches and the floor completely covered with soil and grass to give a natural surface appearance. The cage

was camouflaged and placed in such a manner that the bait could not be clawed and triggered by a leopard from the sides or back of the cage.

Bait used, ranged from dead domestic chickens, guinea fowl (*Numida meleagris*), parts of zebra and donkey carcasses and newly born cattle calves (that died from natural causes), to whole carcasses of baboons, impala and even fresh barbel (*Clarias gariepinus*). Leopard kills used as bait on the spot included cattle calves, impala carcasses, duiker etc.

The closing of trap doors was monitored from a distance by using a transmitter with an on and off switch. A closed door activated the signal and was received with an LA 12 receiver (A.V.M. Instrument Co, California, USA).

Double door walk-in box trap:

Two approaches were used in the double door concept.

The first type was provided by the Problem Animal Unit of the Division of Nature and Environmental Conservation (TPA) (Fig. 3). This cage system consisted of two separate compartments (1,5m x 0,8m x 0,9m) each, with a trapdoor on either side. The framework was covered with 2mm welded mesh (20mm x 40mm).

Live bait (tethered goats) was placed in a pen concealed with thorn branches. A total of six goats were used in rotation, each remaining in the box trap for 24 h. They were fed lucerne and given water twice a day. After each feeding session all lucerne and water were removed. This enclosure's only opening was linked through the cage system. Bait was therefore only visible through the tunnel of the cage system.

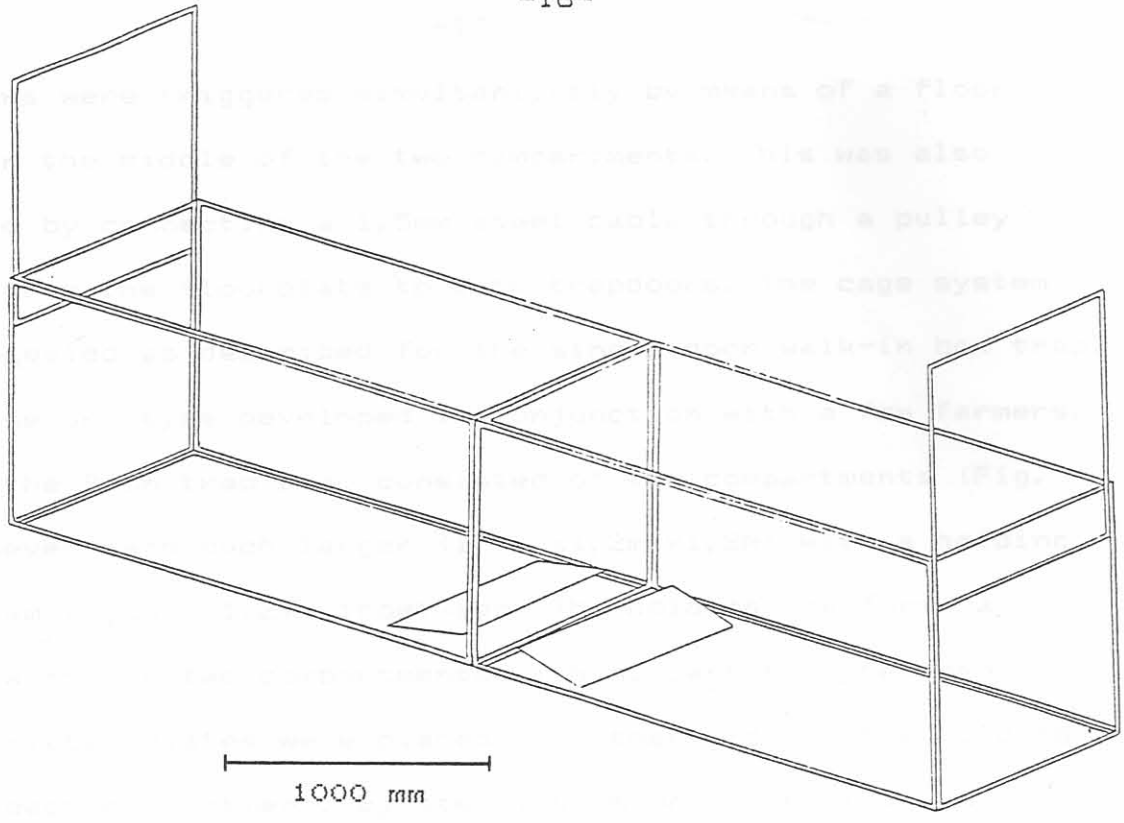

Figure 3 : The TPA Double Door Walk-in Box Trap.

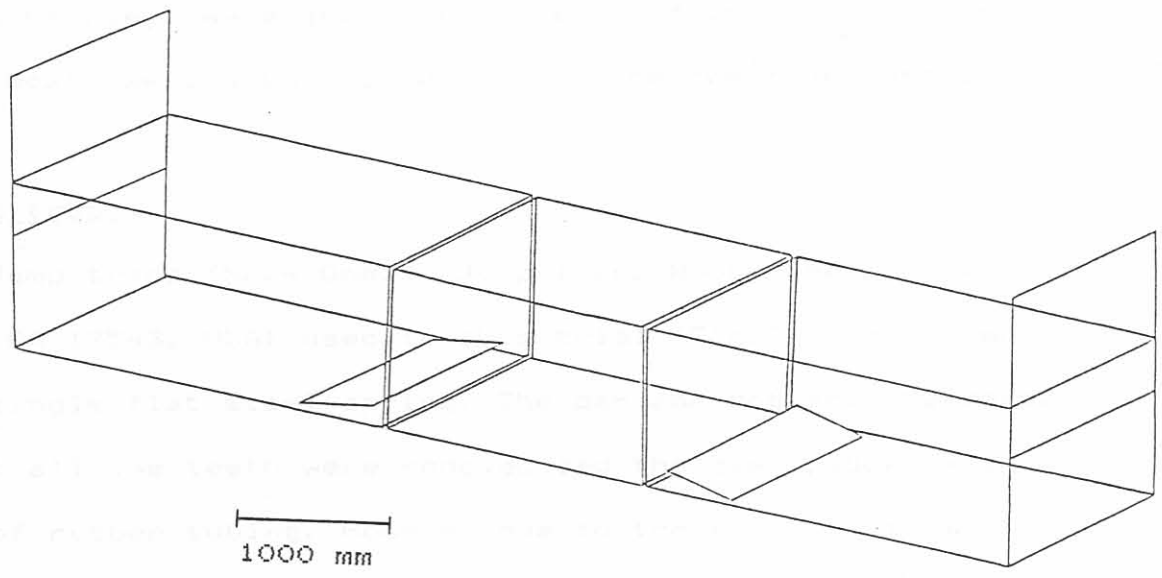

Figure 4 : The Boon Double Door Walk-in Box Trap.

Trapdoors were triggered simultaneously by means of a floor plate in the middle of the two compartments. This was also achieved by connecting a 1,5mm steel cable through a pulley system from the floorplate to both trapdoors. The cage system was concealed as described for the single door walk-in box trap.

The second type developed in conjunction with a few farmers, namely the Boon trap also consisted of two compartments (Fig. 4), however each much larger (1,7m x 1,2m x 1,2m) with a holding box (1,4m x 1,2m x 1,2m) inbetween. The holding box forms a tunnel with the two compartments with no partition between them. Floor trigger plates were placed on either side of the holding box in each compartment. By stepping on only one of the plates, both trapdoors are triggered by means of a cable pulley system.

To facilitate handling in rough terrain, the cage consisted of different frames which could be bolted together at the setting location. The heaviest frame weighed 36,8 kg and the total cage 420 kg. A young domestic goat was held in the holding "box" (area) and tied with a 0,5 meter rope around his neck so that his hindlegs were just out of reach of the two trigger plates. Goats were also rotated as for the previous method.

The Jump trap:

The Jump traps (No. 4 Oneida Jump Trap, Woodstream Corp. Lititz, PA 17543, USA) used in this trial (Fig. 5) are closed with a single flat steel spring. The pan and dog are standard. At first all the teeth were removed and the jaws padded with two layers of rubber tubing. However due to the two individuals escaping, the rubber tubing was removed and teeth replaced. The

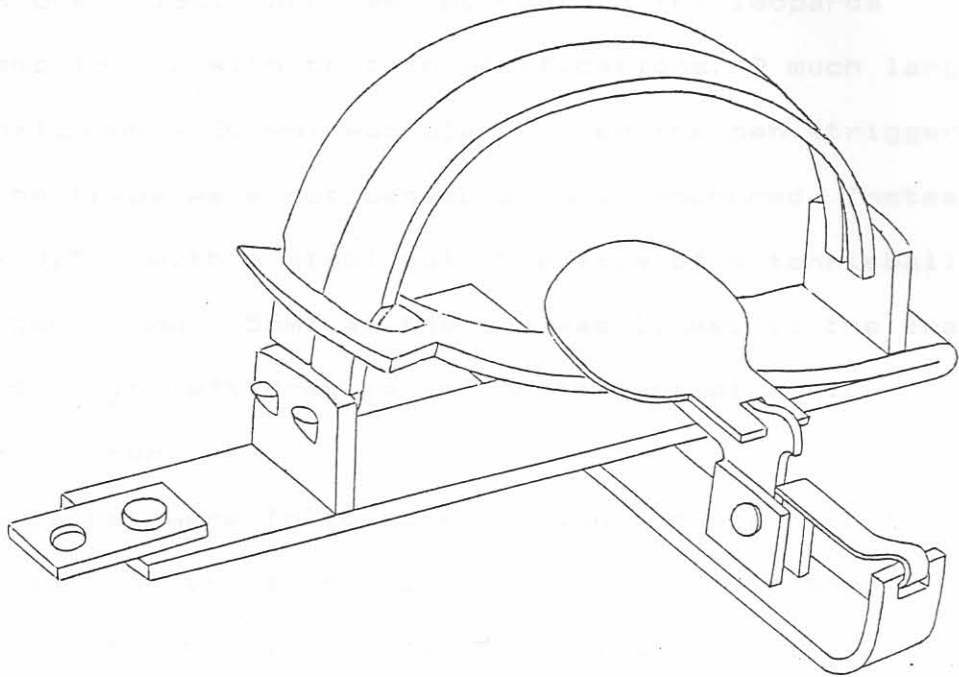

100 mm

Figure 5 : The No 4 Oneida Jump Trap.

strategy of siting and setting of traps was based on the philosophy used for the capture of black backed jackals (Rowe-Rowe & Green 1981) and, as recommended for leopards (Turnbull-Kemp 1967), with certain modifications. A much larger cotton cloth (200mm x 200mm) was placed over the pan (trigger plate) and the traps were not pegged down or anchored. Instead a chain (6mm x 0,5m) with a steel ball the size of a tennisball with knobs (5mm x 5mm x 5mm) at the end was linked to the trap. This ball and chain left drag marks and the animal could therefore be located.

Three approaches were followed regarding the use of bait. The first was to set two traps around a freshly found leopard kill. In addition, due to the difficulty of finding fresh leopard kills, two radio collared young goats were released in the veld and located every morning to find out if they fell prey to a leopard.

The second approach was to put out a fresh carcass or parts thereof and set two traps around it. The best strategy was to use a relatively large carcass e.g. impala or larger, fastened down, and only set the traps once a leopard was known to feed on the carcass. In the third approach developed by M. Keith (pers.comm.) a live goat was fastened against a tree and 6 - 8

*M.Keith

Chief Directorate of Nature and Environmental Conservation

Private Bag X209

Pretoria

0001

jump traps circled just out of reach, around the goat. Goats were also fed and rotated as described for the double door walk-in box traps.

The horizontal double coil spring steel trap:

This trap (Jonker Enterprises, Linton Grange, Port Elizabeth, RSA) with certain modifications (Fig. 6) was used due to shortcomings experienced with the different box traps and jump trap.

The disadvantages of box traps compared to steel traps are being dealt with in the discussion. The shortcomings of the jump trap were related to the speed of jaw closure and holding ability. The actual siting and setting criteria were used as for jump traps. Traps were also not anchored but connected to a chain and steel ball.

Darts were developed based on the van Rooyen dartgun concept in the Kruger National Park (Fig. 7) and mounted on the trap jaws. Three dart covers were mounted on the jaws of each trap. Two on the one jaw and the other in the middle of the other jaw. A 0,8 ml removable dart was placed in each dart cover. Each dart (Fig. 7) consisted of a screw-on perforated needle (10mm x 2mm) with a rubber plunger. A little spring provided the pressure in the dart-body. Due to a volume limitation of 0,8 ml for each dart a drug with a high concentration in small volume had to be used. The drug also had to be stable as the traps were sometimes buried for up to five days. A dosage of 500 mg phencyclidine hydrochloride (Syclan, Centaur Labs (Pty) Ltd, Johannesburg, RSA) (0,5 ml) was used in each dart.

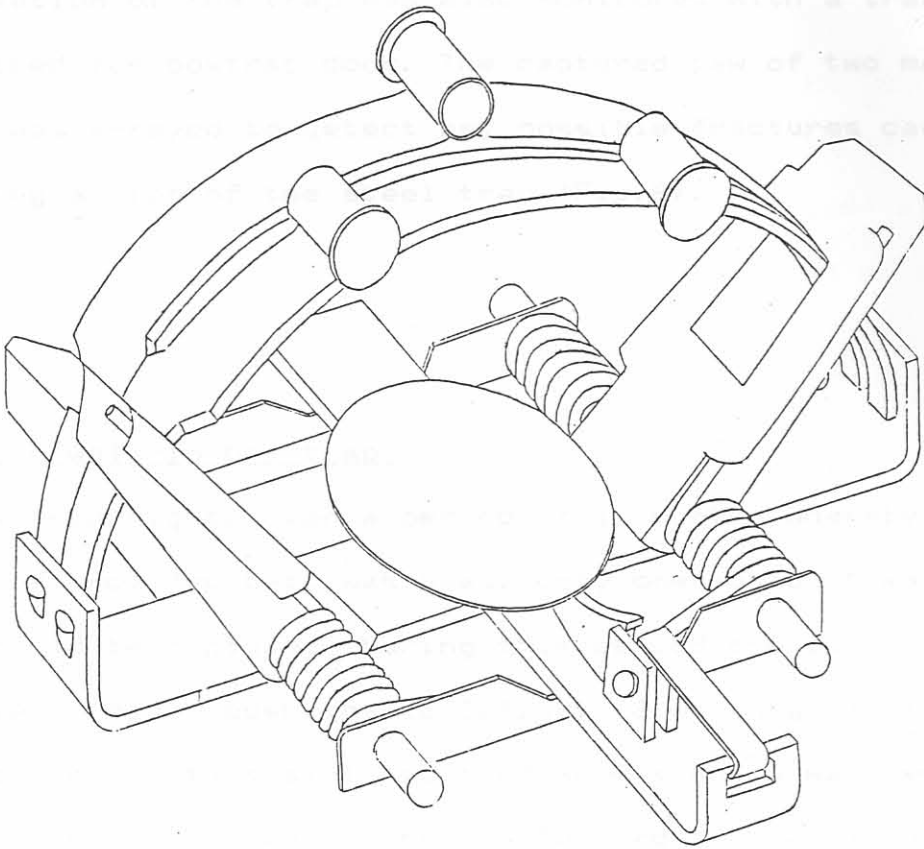

100 mm

Figure 6 : The Horizontal Double Coil Spring Steel Trap.

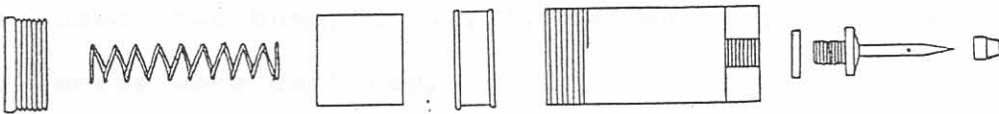

10 mm

Figure 7 : Dart for mounting on the Coil Spring Steel Trap.

The activation of the trap was also monitored with a transmitter as described for boxtrap door. The captured paw of two male leopards was x-rayed to detect any possible fractures caused by the closing action of the steel trap (Fig. 8).

RESULTS

Single door walk-in box trap

In 954 trap nights over a period of 11 months whereby a whole spectrum of provided bait was used, only one subadult male leopard could be captured. During this period one adult female brown hyaena, eight bushpigs (2,2,1,3), 12 warthogs (4,1,1,6), four porcupines, eight small spotted genets and a watermongoose were captured. In six cases where a leopard's own kill was used as bait, and whereby 36 trap nights were involved, only one genet, a bushpig and a warthog could be trapped.

Double door walk-in box trap

The cage systems of the Problem Animal Unit were used in 264 trap nights over a period of eight months. Live goats were used as bait in 72 trap nights over a period of four months. One young male caracal and two porcupines (1,1) were trapped. In the remaining 192 nights where supplied bait (parts of zebra, donkey etc) was used, two bushpigs (1,1), two warthogs and five small spotted genets were captured.

In the Boom trap only live bait (goats) was used. A male leopard was captured during a period of twelve consecutive trap nights.

The Jump trap

Jump traps were used on four occasions at freshly found leopard kills. Nine trap nights were involved. In three instances leopards were actually captured, but escaped after dragging the trap with ball and chain for 10, 20 and 80 m respectively. One brown hyaena female was trapped on the left frontpaw in the third instance and was darted. The leopard did not return to the setting site in the last instance.

Where supplied bait was used in 93 trap nights, a whole spectrum of non target animals were trapped. These included one male brown hyaena, three bushpigs, eight small spotted genets, a male civet and three ratsels (two males and one female). Two sheep carcasses were also put out against a tree without setting the traps. Traps were only put out when a leopard in one case and a brown hyaena in the other case came in to feed. This happened during night three and four respectively. A female leopard approached the carcass again the following night, and was captured. In the case of the brown hyaena only triggered traps were found at the trap site the next morning.

In the third method whereby six jump traps were placed in a circle around a tethered goat, a brown hyaena and a leopard were captured, but both escaped. Twenty one trap nights were involved.

Horizontal double coil-spring steel trap

Two traps were used on four occasions (12 trap nights). A female leopard was captured at an impala carcass, which she killed the previous night. She came in the following morning at

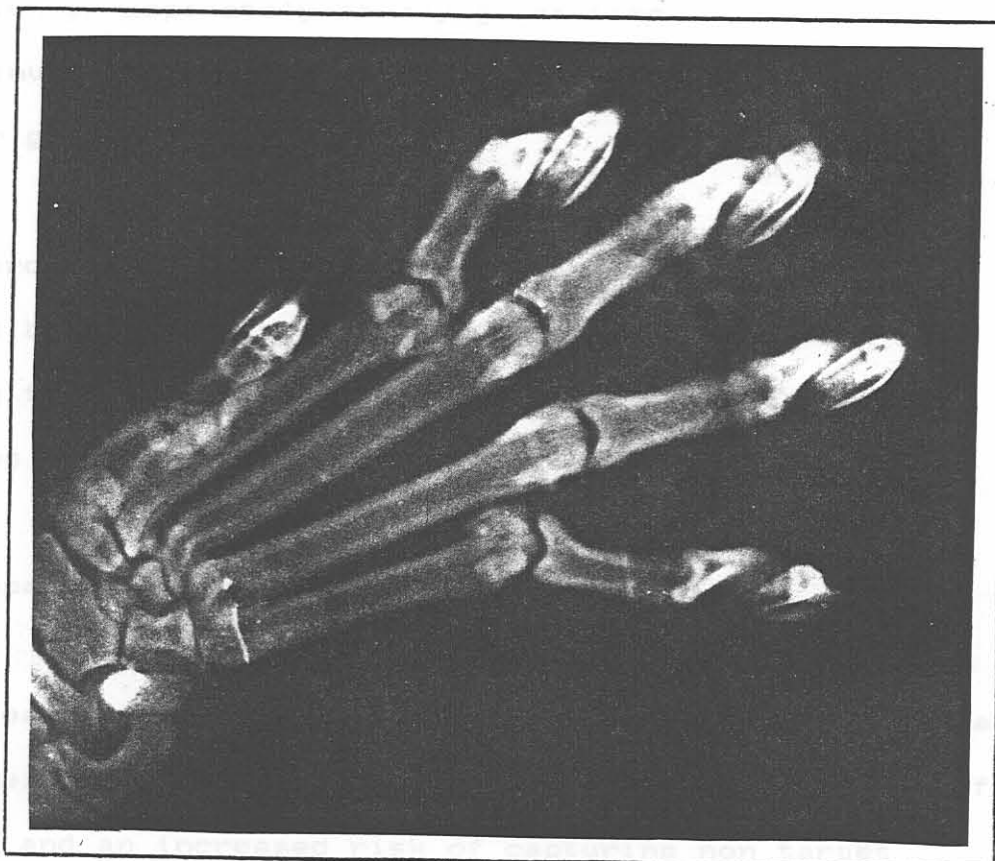
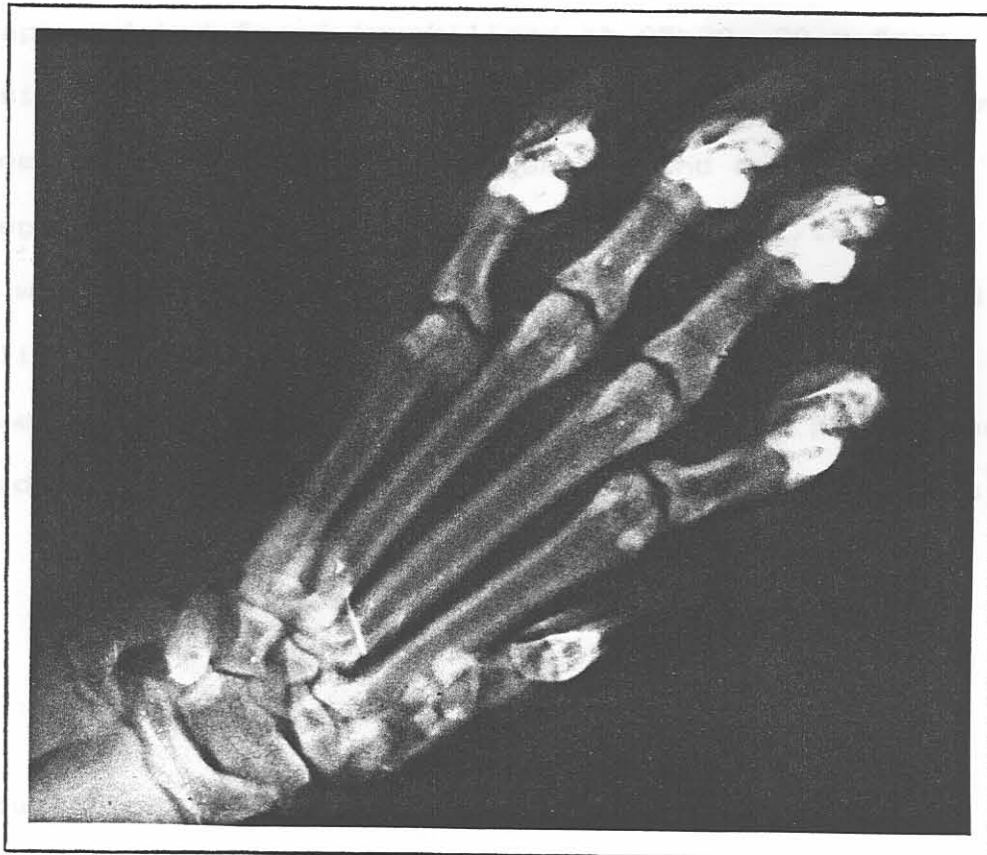

Figure 8 : Normal left paw (top) and steel trapped right paw (bottom) of a female leopard.

04h10, was captured and found immobilized at 05h20, 20 m from the capture site. On occasion a cattle calf carcass was fastened against a tree. A female brown hyaena came in and consumed the right hind leg on the first night. Two traps were set the next morning. She was captured that night at 20h15 on her return and found immobilized 32 m from the capture site at 21h05. Both individuals were captured by the right front paw. The paw of the leopard showed local swelling, but x-rays revealed no fractures (Fig.8).

DISCUSSION

The live capturing of leopards in the Waterberg is mainly hampered by the following factors. These factors may be present in combination or separately at any given time.

- a. The continuous exposure to human persecution in areas of cattle or game farming.

The leopard's inherent sense of shyness and alertness is increased by the fact that they are constantly exposed to capturing techniques. This is especially so where capture techniques failed and animals escaped.

- b. Large leopard home range sizes.

This increases the time interval of leopards revisiting areas within their home ranges. This leads to the decomposition of dead bait and an increased risk of capturing non target

carnivorous species.

c. Interference of other carnivore species.

This leads to the occupation of the trap and subsequently to the spoiling (destruction) of the capture site or the inside of box traps. In many instances months of preparation are wasted and traps must eventually be moved to other areas.

d. Leopard's dietary condition :

Hunger can be an important motivating factor for a leopard to approach bait. This may be relevant in a situation of food abundance and availability but especially so when food is not readily available.

e. Aggression of captured animals.

Some techniques e.g. gintraps etc. may be effective in catching a leopard. This however may lead to serious injuries to the captured animal and also pose a threat to humans approaching the infuriated animal.

The presence and subsequent implications of these factors on the success rate of different capture techniques have given rise to certain adaptations to conventional methods. The impact of the above mentioned factors were manifested in two basic components of the techniques used, namely trap and bait type. The aggression of a snare or gin-trapped leopard (pers.

observ.) and the frequent injuries sustained by humans, in the process (Turnbull-Kemp 1967), made the initial usage of box traps an obvious choice.

Walk-in box traps have been used all over the leopard range with variable success by researchers (Hamilton 1981; Norton and Lawson 1985) and many farmers (Esterhuizen & Norton 1985). Two scenarios are to be dealt with before the secondary factors that influence box trap success are considered. First, where provided bait and secondly where the leopard's own kill is used. It was evident that leopards ignored provided dead bait in freshly set box traps in the Melk River study area. This was irrespective of the bait type or the way in which traps were set (including trees). In 608 trap nights no leopard even attempted to go for the bait. Instead many non target animals were captured. According to tracks, on four occasions leopards (three individuals) did show interest while the traps were set and unoccupied.

In ten cases where a leopard's own fresh kill was used as bait and whereby 45 trap nights were involved only one young adult male leopard could be captured. In the other nine cases the leopards (four individuals) ignored their kill (in the cage) and didn't even attempt to enter the cage. Tracks indicated that they did however investigate the trap.

The fact that only genet was captured showed that interference by other carnivore species was not an important influencing factor. Where the leopard's own kill is used, the effect of two factors namely large home range size and

interference by other carnivores are mainly absent. Furthermore in this scenario, the leopard has made a kill and is therefore expected to be hungry and motivated to feed (Leyhausen 1979). In the process inherent shyness and alertness may play a less important role.

Another factor that could have had a negative impact on the animal's motivation to face a foreign structure in combination with the visual and olfactory disturbance, was the relative abundance and availability of prey items in the Melk River study area at the time. A wary animal suspecting danger will make another kill rather than risk possible danger .

However, over a period of three years just outside the study area three leopards were captured in box traps using old dry skin and bone pieces as bait. The leopards captured were all subadults (two males and one female), probably inexperienced and hungry. They were captured in cages that were placed in position, not interfered with and set year after year. The cage is thereby covered naturally with vegetation and with the absence of any foreign smells.

From the results obtained in the Waterberg and the opinion of farmers it seems that the visual disturbance of box traps was one of the important factors hampering success in a situation where leopards are constantly persecuted. This is further aggravated by over-camouflaging the cage e.g. using excess amounts of fresh (wet) broken branches. Although leopards apparently don't to have a strong sense of smell (Turnbull-Kemp 1967), olfactory disturbances like oil on the doorframes, human urine and deodorants must have a deterrent effect.

A recommended approach regarding the capturing of experienced leopards in box traps with provided dead bait in a situation, where there is abundant prey, is to first reduce the impact of visual disturbance. Traps should be placed on the setting site, only partly covered with a few dry branches to break the symmetry and left alone for months before the actual baiting and setting. This will give the target animals time to get used to the structure. The floor is especially important in that it must simulate the area just outside the cage, including growing grasses and shrubs.

For bait it is recommended that a small to medium sized antelope (e.g. duiker or impala) be shot in the vicinity of the prepared cage. Without touching it with bare hands the rumen should be opened. The whole antelope is then dragged to the cage along a route known to be used by leopards. At the cage the bait is pulled through the door to the other end with a long stick without entering the cage. The bait is connected to the trigger system from the outside.

Two factors however still have a crucial impact on the success of this approach. Due to the large home range sizes of leopards in areas of the Waterberg, it may take days before a leopard enters a specific area. During this time the interference from other carnivorous species is a main threat. Bait also decomposes, especially so in the summer months with much insect activity. This means that a hungry leopard must " by accident " be hunting in the vicinity of the cage at the right moment. This approach is only recommended for long term studies where the time period is not a critical factor.

The major shortcoming of this method is thus the interference by non target animals. The only way to reduce this problem in the Waterberg situation was to change to live bait, together with relevant changes regarding the cage structure.

This led to the application of the double door walk in box trap with a live domestic goat as bait. The goat's role was not only to reduce trap interference but also to lure leopards more efficiently by bleating.

The same principles regarding visual disturbance were relevant and traps were therefore also put out in advance before baiting and setting commenced. In 72 trap nights over a period of four months only one young male caracal could be trapped. On eight occasions leopard spoor (four individuals) were found around the set traps while a goat was in the kraal (pen).

It was thought that the narrow tunnel effect caused by the cage system (three meters) contributed to the animal's suspicion in a live bait situation. The enlargement of the cage, together with the moving of the bait (goat) to the centre of the system, with two entrances, had the necessary effect. This Boon trap is however still to be utilized more extensively, due to the small sample size, before a definite conclusion can be drawn.

While the designing of this alternative approach regarding a cage system was in progress, the application of gin traps was also tested.

Gin traps are one of the most commonly used techniques for the capturing of leopards, especially problem leopards that are to be destroyed (Turnbull-Kemp 1967; Esterhuizen & Norton 1985). This method is also regarded in the Waterberg by most farmers as

the only method to capture "elusive" leopards that are causing damage to stock.

The main advantages of gin traps is their total invisibility and the absence of physical disturbance caused by setting. By using the right procedures (clean traps, cloves and flooring canvas) the detection of smell by elusive leopards is prevented (Rowe-Rowe & Green 1981 for black backed jackal). Gin traps are furthermore mobile and easy to carry to far and remote mountainous terrain. The strategy was to use this successful concept as a basis and make certain alterations to meet the objective, namely capturing an animal alive, radiocollaring and releasing the animal unharmed.

The eight jumptraps were used in three approaches (e.g. trap circle, provided dead bait and leopards own kill). In all cases leopards came in for the bait. Shortcomings of the traps per se however lead to the escaping of all the individuals. First the pans (Fig.5) were much to big and had to be reduced to a diameter of 40 mm. Larger pans resulted in light holds and the subsequent escape of the individual.

A further problem experienced with the jump trap was the speed of closing in comparison with the double coil spring steel trap. The slower jaw action of the jump trap increased the possibility that an animal is captured by the tip of the toe. The better holding ability due to the closing of two springs from either side in the double coil spring steel trap, also prevented escaping.

Gintraps are not fastened with a chain to a tree or a pen as this causes major injuries to the struggling animal's paw. The

exact location of the animal can therefore not be ascertained immediately. This can only be achieved by following the spoor mark left by the iron ball connected to the trap. Nevertheless no matter what precautions are taken, the possibility of a light hold is always there. A sudden charge towards an approaching person in such cases can lead to the animal being freed. Such an aggravated animal will almost without exception attack.

This signifies a major threat to the person nearing the animal. The captured leopard will also not necessarily leave the capture site in the opposite direction of the approacher. The possibility that the chain of the gintrap can get stuck between branches and roots is also not to be ignored. This may lead to injury of the captured animal's paw.

By immobilizing the animal on the closing impact of the trap, the above mentioned possibilities are eliminated. The only limiting factor was the 1 ml capacity of the syringes mounted on the gintrap. The drug also had to be stable for up to five days, as traps are left underground until the leopard returns. Short induction times (0-10 min) and relatively long immobilization times (2-10 h) were important. Phencyclidide hydrochloride was the only available drug at the time with these characteristics.

The unpredictability concerning the return time of the leopard to his bait also influences the success of the immobilization. If the drug is administered at 18h00 and the capture site only visited the next morning at 06h00 the effect of the drug would probably have worn off. It was therefore necessary that the actual trigger time had to be monitored. This was accomplished by the buried transmitter trigger device.