



**THE EFFECT OF INNOVATIVE SCREW ANGLED
MINI-PLATES ON BIOMECHANICAL STABILITY
OF MONO-CORTICAL FIXATION:
AN *IN VITRO* MODEL**

by

FREDERICK JULIUS JACOBS

Submitted in fulfilment of the requirements for the degree

PHILOSOPHIAE DOCTOR

In the

FACULTY OF HEALTH SCIENCES

UNIVERSITY OF PRETORIA

PRETORIA

October 2008



UNIVERSITEIT VAN PRETORIA
UNIVERSITY OF PRETORIA
YUNIBESITHI YA PRETORIA

Dedication:

I dedicate this PhD to the following inspirational people:
my dearest wife, Erica, my children, Marilize, Julius, Erica and Gerhard
Parents Fred and Sophia

Table of Contents

CHAPTER 1	INTRODUCTION	07
CHAPTER 2	REVIEW OF LITERATURE	10
2.1	Mono-Cortical Plating Strategies and its Biomechanical Problem	11
2.2	The Effect of Plating Techniques and Plate Orientation on Biomechanical Stability	11
2.3	Bite Force and its Clinical Relevance to Mono-Cortical Fixation	13
2.3.1	Biomechanical Considerations.....	15
2.4	Angled (Slanted) Screw Application.....	16
2.4.1	Type A: Zero degree slanted screw plate	16
2.4.2	Type B: 45° right side slanted screw plate	18
2.4.3	Type B: 45° left side slanted screw plate	19
2.4.4	Type C: 90° slanted screw plate	19
2.4.5	Type of zero degree slanted screw plate	19
2.5	Anatomical Considerations in Angled Screw Application.....	21
2.5.1	Anatomical consideration for the mandible angle region	21
2.5.2	Thickness of the mandible as applicable in a bi-cortical fixation.....	23
2.5.3	Position of the Neuro-Vascular Bundle	23
2.6	Surgical Approach and Clinical Relevance to Screw Angle Application	24
2.6.1	Trans-buccal/ per-cutaneous surgical approach for screw systems at 90° to the bone plate surface	24
2.7	Screw Angle Comparative Biomechanical Stability Pilot Studies.....	25
CHAPTER 3	PROBLEM AND PURPOSE OF THE IN VITRO STUDY	30
3.1	Statement on the problem and purpose of the in vitro study.....	30
CHAPTER 4	EXPERIMENTAL PROCEDURES.....	32
4.1	The Biomechanical Testing Device.....	32
4.2	Tension/ Compression Evaluation	32
4.3	Torque Evaluation.....	38
4.4	Compilation of Mandible Samples.....	39
4.5	Fabrication of Positioning Templates	41
4.5.1	Mini-plate positioning template.....	41
4.5.2	Segmentation template	42
4.6	Mini-Plate Fixation Procedures	43
4.7	Load Displacement Evaluation.....	46
CHAPTER 5	RESULTS	50
5.1	Biomechanical Testing Device.....	50

5.2	Compression Load-Displacement Results	50
5.3	Statistical Analysis of Compression Evaluation	57
5.3.1	Mean Fixation	57
5.3.2	Statistical Comparison (P-values) of Compression Screw Angle Test (CSAT)	58
5.3.3	Analysis of Load-Displacement Gradients or Slopes	60
5.3.4	Linear trend lines.....	63
5.3.5	Statistical Analysis of Torsion Screw Angle Test (TSAT).....	66
5.3.6	Mean TSAT Stability	67
5.3.7	TSAT Linear Trend Lines	71
CHAPTER 6 INTERPRETATION OF RESULTS.....		73
6.1	Mathematical (Trigonometric) Formulation of Angled Screw Application Results....	73
6.2	Defining and Measuring of STS (Screw Tip Shifting) (Figure 40)	76
6.3	Clinical/Experimental Significance of STS (Figure 40)	77
6.4	Defining and Measuring of Screw Tip Travel (STT)	77
6.5	Clinical Relevance of Trigonometric Calculations (Figure 40)	82
CHAPTER 7 DISCUSSION AND RECOMMENDATIONS		86
7.1	Discussion.....	86
7.1.1	Materials and Methodology	86
7.1.2	The anatomical site chosen for the Inclined Screw Insertion (ISI plate)	89
7.1.3	Independent biomechanical stability testing results of the ISI system	90
7.2	Recommendations for future biomechanical stability investigation and geometrical design aspects of the ISI systems	92
7.2.1	Increased sample size	92
7.2.2	Plate design.....	92
7.2.3	The smart lock technology incorporated in ISI plate designs for the future	92
7.2.4	Additional instrumentation.....	95
7.2.5	Plate Geometry Related To Anatomical Positioning	95
7.2.6	Plate Geometry, Functional Stable Osteo-Synthesis and Strain Lines	99
7.2.7	ISI – Quadrant Orientation and Lag-Effect of ISI	100
7.3	The anatomical study related to the geometric ISI plate design.....	102
7.4	Surgical technique for ISI plate fixation	108
CHAPTER 8 CONCLUSION.....		109
ANNEXURE 1: REFERENCES		111
ADDENDA		114

Figures and tables

Figure 1: Screw angle-quadrant plate hole orientation 8

Figure 2: Lines of osteo-synthesis, orientated along stress line in the mandible.....11

Figure 3: Trans-cutaneous surgical approach13

Figure 4: Muscles of mastication- vectors and force values14

Figure 5: Screw insertion alignment to the fracture line where (A) angled screw insertion-
rectangular to the fracture line and (B) conventional rectangular screw orientation to
plate surface and cortex..... 16

Figure 6: Ramus of the mandible with lateral shearing fractures and 0° slanted screw plate.
Screw application between 0° - 180° (0° original description by Krenkel to describe
the horizontal plane), no screw can obviously be placed at 0° or 180° to the plat
surface 18

Figure 7: Illustration of right sided, oblique orientation angled 45° (no possible lag effect)
screws 19

Figure 8: Illustration of screws with washers in multi-angle plate hole (for screw insertion
angles 0° - 180°) 20

Figure 9: ISI plates applied to lateral aspect of angle of the mandible 21

Figure 10: Section A- Distal root of the second molar. Section B- Distal root of 3rd molar.
Section C- Just posterior of the third molar tooth and the anterior border of the
ramus 22

Figure 11: Cortical thickness at different sections A, B and C related to the mandibular angle
region 22

Figure 12: Depiction of Champy’s ideal lines of osteosynthesis 26

Figure 13: Illustration of cortex transacted with rectangular and inclined screw placement.
Also see Figure 40 27

Figure 14: Inclined Screw Insertion (ISI) plate holes 28

Figure 15: Design sketch of test model arrangement (own design and manufacture)..... 33

Figure 16: Actual testing device-torsion testing via cable on left and compression testing via
load-pin on the right 34

Figure 17: Load-pin experimental set-up 35

Figure 18: Test jig within the Zwick machine 35

Figure 19: Load cell of 50N type 8301 36

Figure 20: Design sketch of test model with mounting base for compression testing in the
Zwick machine 37

Figure 21: Photograph of three-dimensional experimental jig with fixated test module 37

Figure 22: Device for measuring the degrees of rotation at specific torque applications..... 38

Figure 23: Polyurethane replicas with outer dense layer and porous inner core 39

Figure 24: Hemi-mandibles for evaluation 40

Figure 25: Upper and lower plate positions 42

Figure 26: Upper and lower notches for segmentation alignment 42

Figure 27: A curved mini-plate illustrating ISI with plate holes at 90°, 60° 45° or 75°	43
Figure 28: Dedicated drill guides	44
Figure 29: Pilot drilling with aid of drill guide	45
Figure 30: Calibrated torque screwdriver, pre-set at 40 N/cm together with a certificate of calibration.....	45
Figure 31: Design sketches for angle screw holes in L-shaped ISI mini-plates	48
Figure 32: Pilot-drill, used to demonstrate the angled screw-holes in ISI plate	49
Figure 33: Mean fixation of all the CSAT tests.....	58
Figure 34: Mean slope values of the force for delivery graphs of the compression screw angle test for screws placed at angles of 90°, 75°, 60° and 45° as determined by the equation for calculating linear trend lines at a distance of 2-5mm extension.....	62
Figure 35: Linear trend lines for mean force delivery values of the tests for screws plant at angles of 90°, 75°, 60° and 45° TSAT	62
Figure 36: Example of Graphic display of raw data for: TSAT of ISI 60° angle (n-15) test sample	66
Figure 37: Bar graph of mean slope values of TSAT for ISI angles.....	70
Figure 38: Linear torsion trend-lines	70
Figure 39: Screw tip travel and shifting of Inclined Screw Insertion in a mono-cortical application with screw length 7mm and screw diameter 2mm	74
Figure 40: Three CAD simulation of screw angle placement of 30°	76
Figure 41: Horizontally unfavourable fracture right angle of the mandible.....	84
Figure 42: Medial pteragoid muscle action on the proximal fragment of a mandibular angle fracture.....	85
Figure 43: Position of ISI plate of surgical angle of mandible	89
Figure 44: Effect of Screw lagging across the fracture line-stability improvement using longer (9mm) screws*	90
Figure 45: Bone destruction related to ISI of 45° for lag screw.....	92
Figure 46: Screw angle variation of 10° from 90°	93
Figure 47: Inverted omega plate around Foramen mentalis	96
Figure 48: Y-shaped bi-plainer mono-plate.....	96
Figure 49: Proposed geometric designs according to physiological strain lines	97
Figure 50: Lag effect of ISI screw placement.....	98
Table 1: Total mandible thickness at external oblique ridge (Figure 11)	23
Table 2: Load-displacement values in compression for screws placed at 90°, 75°, 60° and 45° respectively.....	51
Table 3: P-values of 90°, 75°, 60° and 45° CSAT tests at distances from 0,5 to 5mm extension.....	59
Table 4: Mean slope gradient values of the force delivery of the SCAT test for screws placed at angles of 90°, 75°, 60° and 45°	60



Table 5: Average slope values for Inclined Screws Insertion (ISI).....	61
Table 6: TSAT values of ISI for 90° placement angles.....	64
Table 7: Standardised load (Newton N) TSAT for ISI of 75°	64
Table 8: Standardised TSAT for ISI of 60°	65
Table 9: Standardised TSAT for ISI of 45°	65
Table 10: The load displacement application for TSAT for displacement values of 2, 4 and 6mm	67
Table 11: Mean torsion force (stress) values of screw angle tests for screws placed at angles of 90°, 75°, 60° and 45°	67
Table 12: Graphic illustration of P-values of TSAT tests for 1 to 6mm displacement. The shaded areas express significance	68
Table 13: Gradient of slope values of ISI angled TSAT	69
Table 14: P-values of the mean slope values for TSAT evaluation	71
Table 15: Mean slope values of the torsion force (TSAT) of the screw angle tests for screws placed at angles of 90°, 75°, 60° and 45°	72
Table 16: Screw tip-shifting results	80
Table 17: Screw tip travel results (lengthening)	82

Addenda

- Addendum 1:** Pilot Study Proposal
- Addendum 2:** Research Protocol
- Addendum 3:** Biomechanical In Vitro Testing
- Addendum 4:** The Mandibulator
- Addendum 5:** White paper for the ISI - fracture plate
- Addendum 6:** USA Patent Registration

**THE EFFECT OF INNOVATIVE SCREW ANGLED MINI-PLATES ON
BIOMECHANICAL STABILITY OF MONO-CORTICAL FIXATION, AN *IN*
VITRO MODEL**

by

Frederick Julius Jacobs

Promotor: Prof Dr Dr Dr K-W Bütow

Department: Maxillo-Facial and Oral Surgery

Degree: PhD

SUMMARY

There is no evidence in the literature of biomechanical stability characteristics comparing conventional rectangular screw placement with that of an angled mono-cortical screw plating system where standard 2mm diameter screws are applied at angles more acute than conventional 90° screws, through plate holes machined (cut) for a definite specific screw angle placement.

Angled screws will have an obvious clinical advantage of direct line of vision insertion, through an intra-oral route without the disadvantage of trans-buccal (cutaneous) approach required for conventional 90° rectangular screw application.

Angled screw application will result in the prevention of possible, less post-operative swelling, nerve fall out (motor and/or sensory), haematoma, false aneurysm and scarring as unwanted clinical complications associated with trans-buccal extra-oral surgical technique. Intra-oral angled screw application will result in definitive cost saving due to less operating time required. Post-treatment removal of angled screws is uncomplicated, requiring only intra-oral surgical approach, without trochar use or skin incisions for screwdriver application.

By determining angle displacement values at certain clinical relevant force values for both compression/tension and torsion, preference can be established for ideal angle(s) of screw application in a plating system. An own unique, designed and manufactured, jig and inclined screw insertion (ISI) plates were implemented during the biomechanical evaluation of stability at different screw angle applications in a Zwick machine. For the purpose of this biomechanical comparative investigation an inclined screw insertion (ISI) plate was manufactured with 90°, 75°, 60° and 45° angled

plate holes orientated in line with the long-axis (quadrant 3) of the distal section of the plates and diagonal across (quadrant 1) in the proximal section of the plates. Screws with an ISI angle of 30° in any quadrant application resulted in lifting the plate from the bone surface and caused cortical bone destruction during pilot drilling.

The results for mono-cortical 7mm screw placement proved superior in biomechanical stability during tension/compression - forces for screw insertion angles of 60° and 45°, when compared to conventional 90° rectangular screw placement. Screws inserted at an angle of 75° demonstrated no improvement in compression/tension stability when compared with 90°. Torsion force stability for all of the 75°, 60° and 45° inclined screw insertion (ISI) systems proved more stable compared to conventional 90° screw angle plates. It is concluded that angled mono-cortical screw placement between angles 60° and 45° has clinical significance as far as stability, intra-oral surgical technique and time-cost factor is concerned.

The results of this biomechanical behaviour investigation of ISI, evolved new terminology such as screw-tip shifting, screw-tip travel, lag potential and clinical significance for the range of screw angle placement. Angled orientation to the plate design and plate geometry is also defined in terms of tension line distribution in the anatomical region for application in the mandible. A unique quadrant description for ISI is described for future communication.

An international patent, based on the ISI principle, has been registered for mono-cortical six-hole plates of firstly different geometric designs to conform to specific anatomical topographic sites in the mandible and secondly specific screw plate-holes angled at 60° in different orientation to the plate (Patent:PCT/EP 2006/006365), (Addendum 6). A specific L-shaped, mandibular angle plate with screw holes at a 60° angle where orientation shifts from in-line with the long-axis of the plate in the distal three plate holes to diagonal orientation in the proximal section of the plate, is designed and manufactured by Stryker/Leibinger as an example of such a patent plate.

It is recommended that a smart-lock plate with plate holes at 55° angles be manufactured to allow screw angle placements of 65° - 45° in different angle orientations. Pilot hole drilling and ISI can be performed without the use of a drill-guide.

DIE EFFEK VAN INNOVERENDE MINIPLATE MET GE-ANGULEERDE SKROEWE OP DIE BIOMEGANIESE STABILITEIT VAN MONO- KORTIKALE FIKSASIE, 'N *IN VITRO* MODEL

deur

Frederick Julius Jacobs

Promotor: Prof Dr Dr Dr K-W Bütow

Departement: Kaak-, Gesig- en Mondchirurgie

Graad: PhD

SAMEVATTING

Daar is geen literatuur beskikbaar aangaande biomeganiese stabiliteitsgedrag van 'n ge-anguleerde mono-kortikale plaat sisteem soos hier beskryf. Die 2mm diameter skroewe, aangewend teen hoeke kleiner as die konvensionele 90°, deur skroefgate, wat spesiaal vervaardig (gemasjineer) is teen 'n spesifieke hoek, is met konvensionele 90° skroef plasing vergelyk.

Deur eksperimentele bepaling van verplasing teenoor kragtoepassing by sekere klinies relevante Newton ladingswaardes vir kompressie, tensie en torsie kan voorkeur vir 'n spesifieke skroefangulasie(s) bepaal word. Die aanwending van 'n unieke eie ontwerpte en vervaardigde monterings-apparaat in 'n Zwick masjien maak dit moontlik om verplasing teenoor spesifieke krag toepassing in Newton deur die komper te registreer.

Die resultate vir mono-kortikale 7mm lank skroewe het vir geanguleerde plasing teen 60° en 45° biomeganies deurgans beter stabiliteit gedemonstreer in vergelyking tot konvensionele 90° 7mm skroef plasing 'n aanwendingshoek van 75° vir mono-kortikale 7mm skroewe het nie biomeganies betekenisvol verskil van 'n 90° skroefaanwending nie, terwyl 'n aanwendingshoeke van 30° vir 'n mono-kortikale skroef nie klinies moontlik is nie. Vanuit die resultate van hierdie biomeganies geanguleerde skroefplasing studie is nuwe terme gedefinieer soos skroefpunt verskuiwing, skroefpunt verlenging, lag-potensiaal en kliniese relevansie vir die angulasie reikwydte van skroefplasing. Angulasie oriëntasie tot die skroefplaat geometrie is ook gedefinieer.

Vir die doel van hierdie biomeganies vergelykende stabiliteit studie is spesiale geanguleerde skroefgat plate met skroefgat angulasies van onderskeidelik 90°, 75°, 60° en 45° gebruik.

60° & 45° deur Stryker/Leibinger vervaardig waar die angulasie oriëntasie van alle skroefgate in lyn met die langas in die distale segment en koronaal teenoor die proksimale segment van die plaat was. Die spesiale plate is as die inklineerde skroef inplasing (ISI) sisteem benoem.

Die resultate van hierdie biomeganiese analise het nuwe terminologie gevestig soos skroefpunt verskewing, skroefpunt verlenging en die potensiaal van 'n skroef om die fraktuur lyn te oorbrug indien geplaas teen 'n spesifiek angulasie. Die skroefgat angulasie en plaat geometrie is ook ten opsigte van tensie lyne en anatomiese plasing gedefinieer. 'n Unieke kwadrant beskrywing vir skroefgat angulasie is omskryf om toekomstige eenvormige kommunikasie te verseker.

'n Internasionaal geregistreerde patent is gebaseer op die resultaat van hierdie studie as (1) 60° ses-skroefgat mono-kortikale plate van (2) verskillende geometriese forme vir intra-orale chirurgiese tegniek en aanwending in verskillende anatomiese posisies in die mandibula (Patent: PCT/EP2006/006365), (Addendum 1). Die L-vormige ses-gat, mono-kortikale kaakhoek plaat met 60° skroefgat angulasie het oriëntasie in die langas van die plaat in die distale segment en die oriëntasie koronaal (dwars) tot die plaat in die proksimale segment, en is n voorbeeld van die "ISI"-sisteem (Inklineerde Skroef Inplasing) spesifiek ontwerp vir aanwending in die kaakhoek van die mandibula en geometries ontwerp om ooreen te stem met die ideale stress-lyne vir fiksasie op die ventrale aspek van die eksterne skuinsrif.

'n Aanbeveling word gemaak dat 'n "smart-lock" universele 10° variasie geanguleerde skroefgat, ontwerp vir skroefplasing teen 55°, vervaardig word wat skroefangulasieplasing tussen 65° en 45° klinies moontlik sal maak deur dieselfde skroefgat. Geen boorgids sal nodig wees nie en die inklineerde skroefangulasie sal moontlik wees in verskillende kwadrant oriënterings.

ACKNOWLEDGEMENTS

1. Psalm 111:10 – The fear of the Lord is the beginning of wisdom; all who follow his precepts have good understanding. To Him belongs eternal praise.
2. My beloved wife and family, for their continuous support and encouragement.
3. Professor Kurt Bütow, my mentor for his devotion, guidance and inspiration.
4. Stryker/Leibinger Company:
 - a) Generous funding, manufacturing of unique mini-plates, supplying materials and advice from the Freiburg team:

Design Engineers

 - i) Christian Knoepfle – Chief Engineer, Research and Development
 - ii) Alexander Knabben – Project Engineer. Research and Development
 - b) The participants in the mandibular angle fracture plate project for contracting and design details:
 - i) Gregg Heath - Business with Director Styker Leibinger
 - ii) Hans van Hees - Vice President, Training
 - iii) David Mercado – USA Marketing
 - iv) Claudia Graeve – Project Manager, Leibinger micro implants, Stryker Europe, Middle East and Africa.
 - v) Michael Moynihan – Europe Marketing
 - c) Dr. Ing. Heinrich Schieferstein of München for conducting the biomechanical stability testing of the first prototype of the mandibular Inclined Screw Insertion (ISI) angle plate using the unique mandibulator he designed at the Technical University of Munich in 2005.
 - d) The patent attorneys, Wuesthoff & Wuesthoff, for the International patent registration: PCT/EP2006/006365 - “Osteosyntheseplatte mit schräg zur Plattenebene verlaufenden Durchgangsöffnungen”, as Prof F.J Jacobs received the inventor status and Stryker/Leibinger are the patent holders.

5. Mr Jan Mentz – University of Pretoria managing marketing and legal aspects of the patent and negotiations with the South African Reserve Bank in applying for exchange control approval.
6. My colleague, late Professor P.L. Kemp for unselfish support and true enthusiasm throughout and for initial proof reading of this documentation.

CHAPTER 1 INTRODUCTION

The effect of screw angle placement on biomechanical stability of mono-cortical plating should evolve from an understanding of mandibular biomechanics as a functional unit.

For the purpose of this specific investigation a mandibular angle fracture model was created^{1,2} using polyurethane human mandible replicas with elastic modulus $1/10$ that of bone, to perform a mono-cortical fixation using unique ISI (Inclined Screw Insertion) plates manufactured for this study. The mandibular angle was chosen as the anatomical area of interest as all rigid internal plating systems applied to the lateral aspect of the ramus/angle, according to the second Champy ideal osteosynthesis line³ [located infero-lateral (caudal) to the external oblique ridge] demand trans-cutaneous approach in order to apply screws at the conventional 90° angle to the plate surface. An angled screw application will allow plating via preferred intra-oral approach. The vast array of fixation devices with fixation positions have been introduced in the management of mandibular angle fractures. Mini-plates, for the past two decades, are widely used according to the principles described by Michelet and co-workers⁴ and Champy and co-workers where plates are placed along physiological functional tension lines. There are many experimental studies simulating fractures at the mandibular angle in a model and testing the stability of different osteosynthesis methods.⁵⁻⁷

The introduction of an unique own-designed and manufactured testing device with a load protocol to investigate compression/tension and torsional load displacement values of the mandible within known clinical relevant parameters, is proposed.⁸⁻¹¹

The complete absence of other studies on the biomechanical behaviour of angled screw-hole plates prompted this investigation in search of a more stable mono-cortical osteo-synthesis with the probability of intra-oral application screw angles can be differently orientated to the long-axis of a plate and this has been described as a quadrant method explaining the concept (Figure 1). Variations to conventional rectangular screw placement depicted by the vertical line through the plate-hole, can be described as a semi-circle diagonal to the long-axis of a plate and sub-divided into quadrants one and two (1 & 2) or the orientation of the screw angle can be in a semi-circle parallel to the long-axis of the plate geometry in quadrants three and four (3 & 4).

Zero degrees (0°) is represented by the plate surface and a vertical line through the centre of a plate-hole represents rectangular (90°).

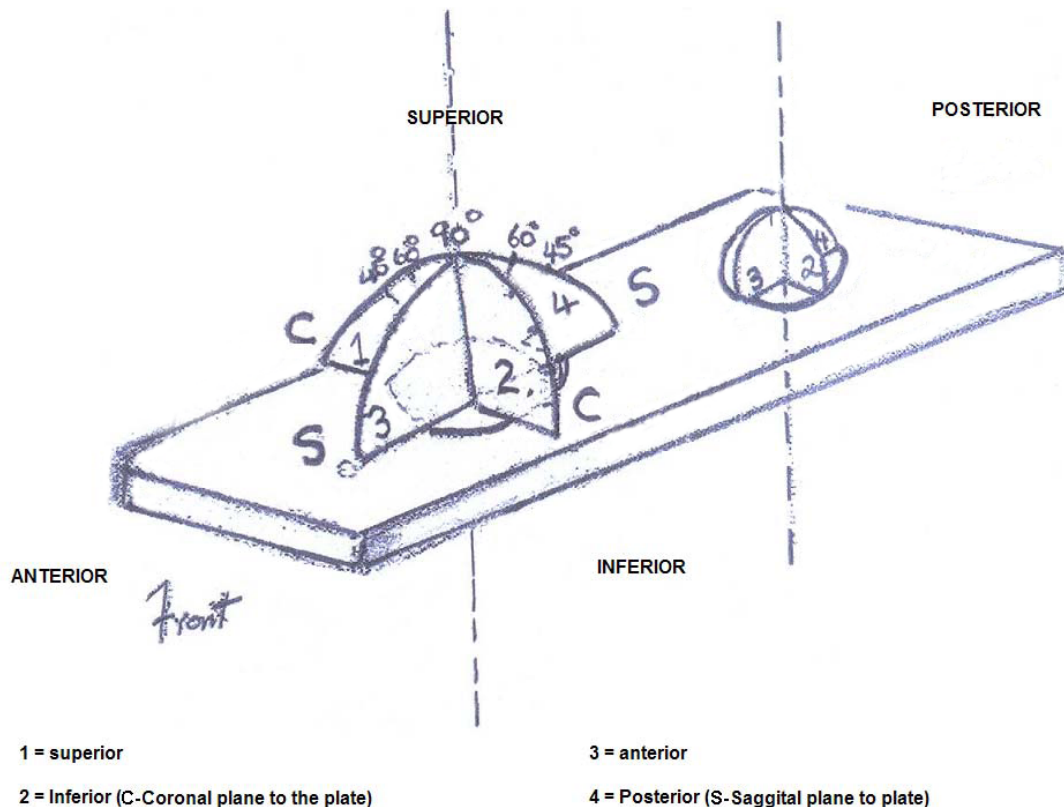

Figure 1: Screw angle-quadrant plate-hole orientation

For the purpose of this investigation all screws were placed in quadrant three at the prescribed angle orientation in the length of the plate for all plate holes in the anterior (distal) fracture-fragment section of the plate and quadrant one for the plate holes in the vertical (proximal) fracture-fragment section of the six hole plates used.

Plating the ventral (lateral) aspect of the external oblique line in a mono-planar, mono-plate fashion with angled screw insertion is unique and is tested according to sound biomechanical principles with proven clinical relevance.

The mono-cortical ISI plates, used in this study, were geometrically identical except for the screw-hole angles. Fracture simulation as an oblique (saw cut) separation at the angle of the mandibular resembled a most unstable fracture situation, clinically relevant to a horizontally and vertically unfavourable fracture. Compression Screw Angle Testing (CSAT) was performed investigating cantilever forces. Tension Screw Angle Testing (TSAT) investigated torsion force stability for angled screw application.

The load point for compression/tension force application was constant without an attempt to discriminate between incisal and / or contra-lateral molar loading. The load/displacement data was kept within the clinical significance of 0 to 200N where torsion would relate to a load point positioned at the contra-lateral molar region. All conventional mono-cortical systems used in rigid fixation of angle fractures with screw angle application of 90°, fail to meet post-operative functional requirements for force values of 200N. The force normally applied under clinical loading of incisal edge and contra-lateral molars, thus inflicting a combination of torsional and vertically deforming forces, are simulated in this investigation by separate compression and torsion testing at 200N load force¹² to create an instability factor. The outcome of this investigation should give clinical significance to a preferred screw application, which facilitates intra-oral application to a fracture line located in any anatomical region of the mandible.

A fixation plate design that demonstrates angled screw holes for fixation of temporomandibular joint prostheses, to facilitate drilling and screw application through a pre-auricular incision, has been previously published.¹³

CHAPTER 2 LITERATURE REVIEW

2.1 Mono-Cortical Plating Strategies and its Biomechanical Problem

Finding clinical relevant parameters for this *in vitro* study of biomechanical bite forces was a high priority. It is important to relate angled screw application to the controversial aspect of mandibular angle fracture management, which is likely to benefit most from angled screw application.

2.2 The Effect of Plating Techniques and Plate Orientation on Biomechanical Stability

The *in vitro* studies with two-dimensional models described by Champy and co-workers in 1978, show tension effects at the level of the dentition and compression effects at the level of the lower border. With regard to angle fractures three observations can be made in mono-cortical plating of the polyurethane synthetic mandibles.³

- a) A superior border plate cranial to the external oblique ridge, where intra-oral surgical technique and instrumentation is sufficient to perform a mono-cortical plate-fixation, appears to be less resistant to bending forces during loading.
- b) A laterally positioned plate is more resistant to vertical forces but still allows a certain amount of lateral movement.

Clinically this type of osteosynthesis requires additional trans-buccal instrumentation if conventional rectangular screw placement is performed. A scenario which will change to a more user-friendly intra-oral surgical technique if angled screw insertion is employed.

- c) In cases where the fracture line is completely vertical to the masseteric-pterygoid muscle sling, must be expected that the distraction effects during chewing and loading in the fracture region will result in even more displacement at the lower border, which apparently cannot be resisted by a single plate on the tension side.¹⁴ These fractures are both vertically and horizontally

unfavourable in terms of displacement. Finally, in all mono-cortical plate osteosynthesis cases, fractures are seldom in close apposition on the lingual aspect, regardless of careful adaptation of plates to manually reduced fragments. In the angle region slight gaps at the lower border region in all conditions may be the result of the tension effect of screws in combination with a slight under-bending of the plate. It is generally accepted that during function of the lower jaw, tension will occur at the level of the dentition whereas an effect of compression will be observed along the lower border. In the chin area, symphysis torsional forces produce a combination of tension and compression.¹⁴

Fixation of mandibular fractures by mini-plates, derived from the system developed by Michelett⁴ for treatment of mid-face fractures, was implemented by Champy.³ The mini plates were applied close to the tension zone of the mandible. Because of the dentition and the alveolar nerve structure, the screws are required to be mono-cortical. Champy¹⁸ claims that this mini-plate system also provides sufficient support and stability to the bone fragments of a lower jaw to allow immediate function. Champy mentions three different zones in the mandible for application of the plates delineating ideal lines of osteosynthesis.³ Firstly, a neutral zone located sub-apical to the dentition in the lateral portion of the mandible, in this location, one plate is sufficient. Secondly, a two-level zone between the mental foramen in which to plates have to be placed to resist the tensional loads. Finally, the region of the angle in which fixation can be performed with one plate, applied lingually (cranial) or buccally (caudal) of the external oblique line to optimise stability (Figure 2).

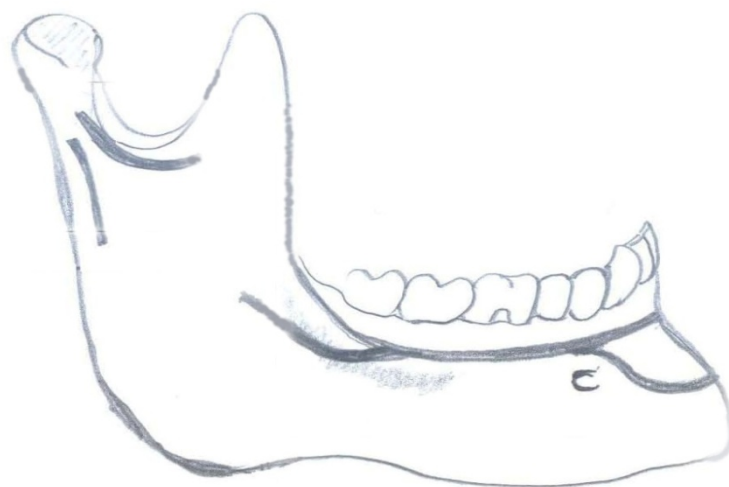

Figure 2: Ideal lines of osteosynthesis, orientated along stress line patterns in the mandible (Condylar neck: Meyer and Corpus: Champy)

Unilateral loading distributed from premolar to molars, will cause increasing distraction at the fracture site at the lower border. This effect is bigger with a secured plate on the superior aspect of the mandibular angle, cranial to the external oblique line as would be with a plate fixed caudal (infero-lateral) of the external oblique ridge as it would be with a fixed caudal (infero-lateral) of the external oblique ridge (the anatomical site chosen for the application of the ISI plate which also corresponds with the strain lines).

All the *in vitro* experimentation regarding mono-cortical fixation of mandible fractures should reveal clinical evidence and relevance to justify plating patterns. In this regard, the treatment of mandibular angle fractures is a very controversial issue with very few prospective studies¹⁵ and, if published, the exclusion criteria are often not well defined, especially in regard to the vertical or horizontally favourable or unfavourable nature of fractures. Currently, popular conventional screw application in most mono-cortical plating systems is rectangular to the plate surface where extra-oral trans-buccal approach is required as in screw fixation of bilateral sagittal split osteotomy fragments or plate fixation on lateral aspect of ramus for mandibular angle fractures. Any plating procedure to the lateral aspect of the ascending ramus and angle of the mandible, demands a stab incision for trans-cutaneous screwdriver trochar and subsequent rectangular screw application (Figure 3). This procedure is associated with possible complications such as scarring, trigeminal and facial nerve damage, bleeding and technical difficulties if it becomes necessary to remove the screws at a later date. Increase in theatre time has cost implications¹⁶ when using a trochar and trans-cutaneous approach.

Maxillo-Facial surgeons have moved away from extra-oral techniques with the superior border mini-plates via intra-oral approach becoming the norm for the treatment of simple mandibular angle fractures. Mandibular angle fractures and the management by either single 2mm mono-cortical superior border plate (mono-plating mono-planar), bi-plating in bi-planar fashion^{17 - 19} (one plate on superior border and one on lateral aspect of angle) or bi-plating in a mono-planar fashion²⁰ superior and inferior on the lateral aspect has become a contentious issue with regard to their inherent biomechanical stability and gapping at the lower border.



Figure 3: Trans-cutaneous surgical approach

2.3 Bite Force and its Clinical Relevance to Mono-Cortical Fixation

As clinicians are using smaller devices with mono-cortical screws, stability of treated fracture segments should at least be in excess of the critical load characteristics for the fracture fragment displacement. Clinically relevant parameters for *in vitro* force application can be deducted from information of the post-surgical population relative to non-operated healthy individuals.

Bite forces in the acute post-operative period are much less than bite forces recorded later in the healing phase and in non-operated individuals.²¹ These observations were confirmed when post-operative biting forces were evaluated in 22 patients treated with mini-plate osteosynthesis.

Gerlach and co-workers²² studied masticatory forces in patients with fractures of the mandibular angle, maximum bite force evaluations demonstrated 31% of normal vertical load one week post-operatively and increased to 58% in the six weeks post-operatively in patients treated with mini-plate osteosynthesis for mandibular angle

fractures due to neuromuscular protection. Therefore, the muscle force vectors for the major muscles of mastication can be reduced to 30% (Figure 4).

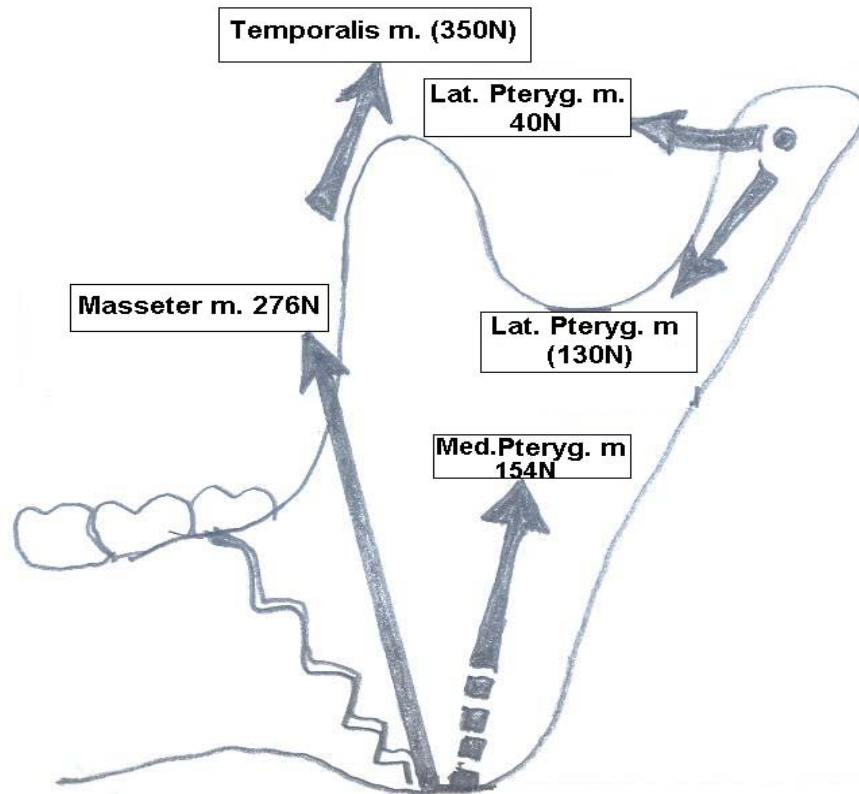

Figure 4: Muscles of mastication (vectors and force values)

Incisal edge loading within 0 to 100 Newton range, and load displacement values for contra-lateral motor loading within 0 to 200N range are considered to be clinically relevant for evaluation of mechanical behaviour of mono-cortical fixation. Masticatory loads following the fixation with mini-plates, exceed 200N three months after osteosynthesis. Several biomechanical stability studies are rendered insignificant as test forces used exceed clinical functional forces.²² *In vitro* testing within clinically relevant parameters (100 - 200N) should be the norm in comparing the mechanical properties of the different possible fixation philosophies.

In order to adequately investigate the biomechanical behaviour of the various fixation philosophies, a unique testing device was designed and manufactured. The device is located in the Zwick testing machine and allows precise recording of three-dimensional load displacement values of synthetic polyurethane mandibles.

Orthopaedic research has shown better results for torsional load if screws are placed perpendicular to a fracture plane. When bending moments are applied perpendicular to the plane of the screws, screws should be positioned perpendicular to the fracture plane.²³

Angulated screws in oblique fracture lines, as seen in angle fractures of the mandible, will tend to be more rectangular to the fracture line. Screws placed conventionally through plate holes rectangular to the outer bone cortex, cannot be rectangular to the oblique fracture lines (Figure 5).

2.3.1 Biomechanical Considerations

In the past three decades, a variety of studies has contributed to the conceptualisation of the biomechanical principles dictating mandibular behaviour during normal function. The two-dimensional models demonstrate tension at the level of the dentition and compression at the lower border of the mandible whereas the three-dimensional approach includes forces of the musculature on the balancing side during mastication. Based on these principles, different methods of plate fixation have evolved to solve the problem of displaced fracture segments.

Currently, controversy continues unabated with regard to the use of one or two mini-plates in mono-cortical plating for the purpose of providing adequate support and stability to facilitate effective immediate function.

In the conventional plating systems, stability is derived from tightening the screw perpendicular to the mini-plate and adjacent bone. Anatomical constraints limit intra-oral access for bi-planar placement of the plate located on the lateral surface of the external oblique ridge. The difficult anatomical access necessitates compensation by drilling and screw application at an angle other than the required right angle. This practice results in an inevitable acute placement angle of screw, screwdriver and screw to bone interface or use of trans-cutaneous surgical approach.

Viewed from a biomechanical perspective, mono-cortical engaging screws inserted at an angle smaller than 90° have a longer surface area of interfacial cortical bone contact and this factor may eliminate the theoretical disadvantage of screw placement at 60°- angle to the bone surface. If this principle is applicable, it can be

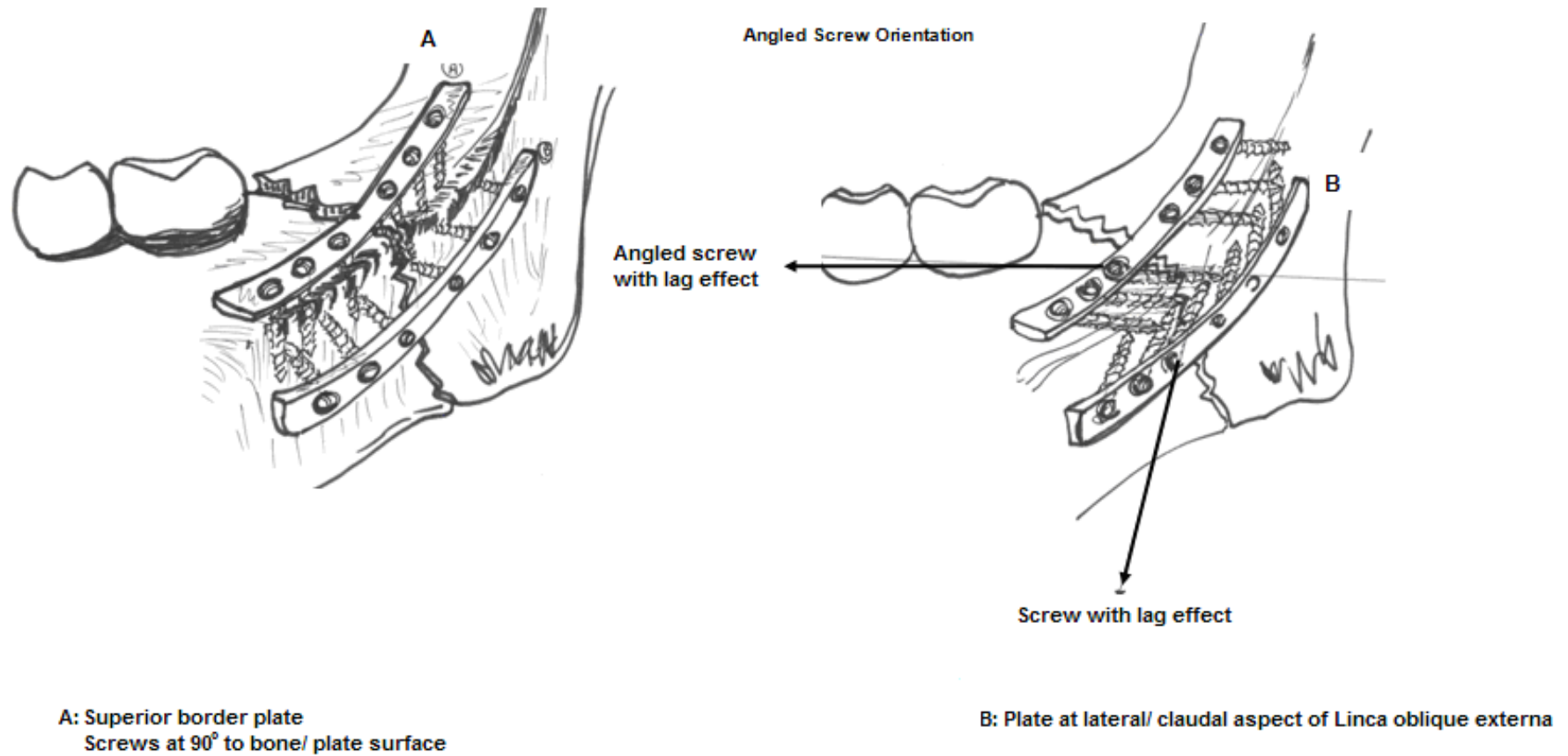

Figure 5: Screw insertion alignment to the fracture line where (A) angled screw insertion-rectangular to the fracture line and (B) conventional rectangular screw orientation to plate surface and cortex

assumed that the 60° and the 90° configurations should exhibit similar biomechanical characteristics.

If an intra-oral plating system with plate holes at angles <90° were to be designed and placed to coincide with the second more lateral line for ideal osteosynthesis, as described by Champy (Figure 2), its biomechanical properties should be investigated and compared to conventional 90° angle screw placement.³

2.4 Angled (Slanted) Screw Application

Krenkel²⁴ describes principles of the slanted screw plate as follows: “Use of the screw plate is based on the fact that the plate screws can be inserted at angles of between 90° and 30° to the plate surface (*Comment: the 30° screw angle of insertion has, in this study, been proven to be not clinically viable*”). The screw head receptacle in the plate is spherical with an oblique insertion groove for the small screw-head which is also rounded on the underside. Four different kinds of slanted screw plates (numbered: A to D) meet most of the requirements arising in maxillofacial surgery. These are made as multi-hole plates in a strip and are cut to suitable length by the surgeon and cannot be contoured to change their shape to be placed along tensile strain lines for all anatomical sites in the mandible.

2.4.1 Type A: Zero degree slanted screw plate

A zero degree slanted screw plate was used by Krenkel as a term in his explanation to describe screw insertion in horizontal plane between 0° - 180°. The screws are inserted from one side along the long axis of the plate. The plate can be used on either the left or right side as an alternative treatment modality for condylar neck fractures. The plate-holes should accommodate screw insertion from 0° to 180° along the long axis of the plate (Figure 6).

The most recent development of the Trapezoidal Condylar Plates (TCP)²⁵ for functional stable osteosynthesis of fractures in the sub-condylar and condylar region has emphasised the fact that plates should be anatomically specific and geometrically designed along functional tensile strain lines. This *in vitro* study performed on human cadaver mandibles effectively led to optimising the plate design but has plate-holes rectangular to the plate surface. Angled screw-holes in these plates, with the correct

angle orientation, would optimise clinical surgical technique favouring either pre-auricular or sub-mandibular surgical approach and be superior in stability compared to rectangular screw insertion.

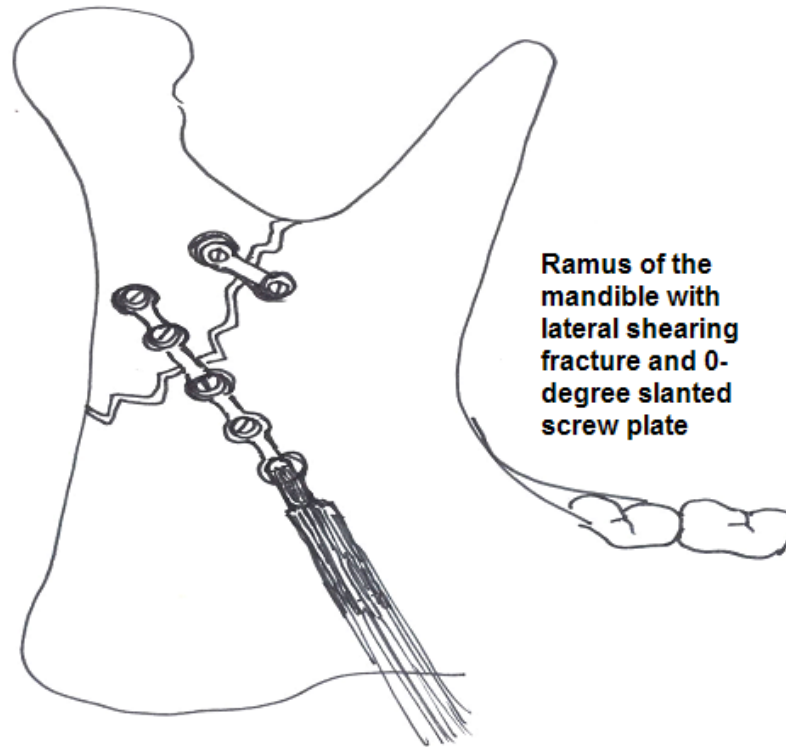

Figure 6: Ramus of the mandible with lateral shearing fractures and 0° slanted screw plate. Screw application between 0° - 180° (0° original description by Krenkel²⁵ to describe the horizontal plane), no screw can obviously be placed at 0° or 180° to the plate surface

2.4.2 Type B: 45° right side slanted screw plate

The screws are inserted from one side at an angle of 45° from the right of the long axis of the plate. This plate can only be used on the right side (Figure 7).

2.4.3 Type B: 45° left side slanted screw plate

The screws are inserted from one side at an angle of 45° from the left of the long axis of the plate. This plate can only be used on the left side.

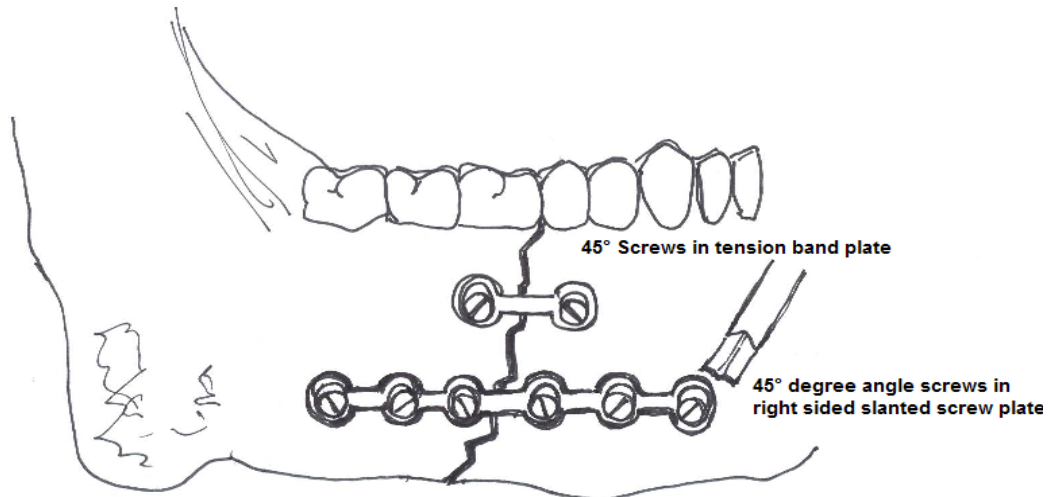

Figure 7: Illustration of right sided, oblique orientation angled 45° (no possible lag effect) screws

2.4.4 Type C: 90° slanted screw plate

The screws are inserted from one side at an angle of 45° crosswise to the plate. The plate can be used on either side. The various slanted screw plates are also suitable for other indications; for example, as a primary osteosynthesis plate in the area of the angle of the mandible and in the body of the mandible. Compared to the conventional mini-plate, the slanted screw plate can be easily removed through a small incision because the screw heads are turned toward the oblique surgical access and there are fewer disturbances to the soft tissue. This applies not only to the region of the condylar process but for all intra-oral access for the osteosynthesis of mandibular fractures.

In addition the slanted screw plate may be used as a safety and slanted screw tension plate to add stability to anchor screw osteosynthesis already in place at the upper or lower border of either the body or angle of the mandible.

2.4.5 Type of zero degree slanted screw plate

The screws can be inclined between 0°-180° in the plate holes (0° description by Krenkel²⁴) as illustrated (Figure 6).

Angled screw plates: design is complicated by the fact that the screw holes were not cut at a definite angle but rather bevelled to allow variable angle placement (0° and 90° or at slopes allowing 45° placement). This complicated screw-head seating and required washers or oblong holes as shown in Figure 8.

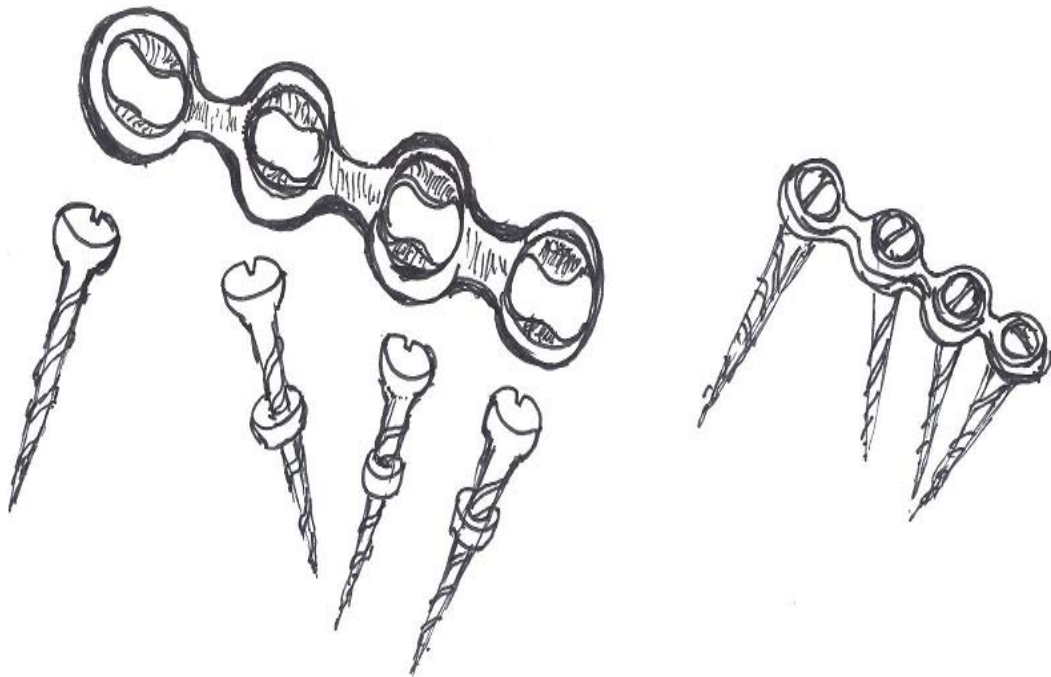

Figure 8: Illustration of screws with washers in multi-angle plate hole (for screw insertion angles 0° - 180°)

These screw plates were used as bi-cortical systems in the ramus and inferior border of the mandible. The plate types A to D are all straight in their design and do not demonstrate plate geometry for placement along specific tensile strain lines which are the basic requirements for functional stable osteosynthesis.

Mono-cortical plating on the lateral aspect of the angle of the mandible using the Inclined Screw Insertion (ISI) mini-plate design, as proposed by the author has been provisionally evaluated.²⁶ The design concept is illustrated in

Figure 9.

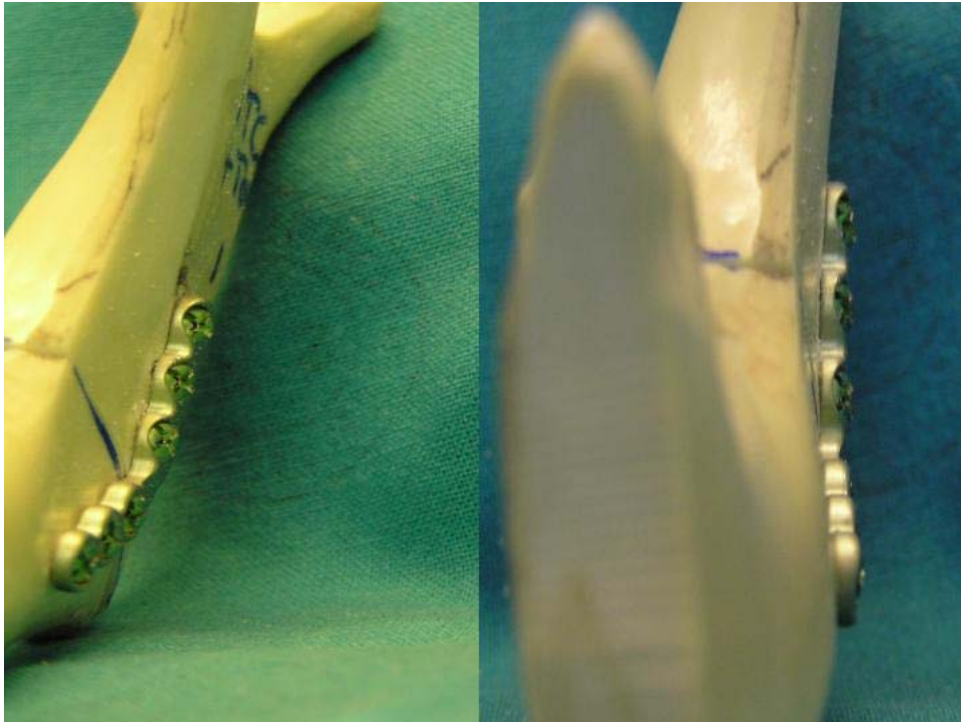

Figure 9: ISI plates applied to lateral aspect of angle of the mandible

2.5 Anatomical Considerations in Angled Screw Application

Viable surgical procedures are dependent on knowledge of the anatomy of the angle of the mandible, including the position of the inferior alveolar neuro-vascular bundle. Furthermore, cortical bone plate thickness varies in the retro-molar area of the mandible which is important when inserting mono-cortical rigid internal plate fixation.

2.5.1 Anatomical consideration for the mandible angle region

2.5.1.1 Cortical thickness in relation to rigid mono-cortical fixation in the mandible angle

Optimum screw length for a mono-cortical screw will engage or transect all the available dense cortical bone for a specific anatomical site if done rectangular to the bone surface 90° at points anthropological interest for screw hole placement. It is

known that inferior cortical thickness is very thin at the mandibular angle as opposed to the anterior mandibular region. The cortical plates buccal and lingual at the external oblique ridge of the human mandible are significantly thicker than at the inferior border in terms of cortical thickness, there appears to be mono-cortically at the external oblique ridge over placement. More inferiorly comparative anatomical studies of the mandibular area measured at the external oblique line and 5mm above the inferior border proved that the buccal cortical plate is thicker at the external oblique line (mean: 3.0 to 3.5mm) than at 5mm above the interior border (mean: 2.2mm to 2.5mm) by 0.9 to 1.1mm. This difference was significant ($p < 0.001$) at Sections A, B and C.²⁷ The thickest cortex is found in the superior-lateral aspect in the third molar area (Figure 10 and 11). Results supported by Heibel and co-workers in a more recent study of autopsy material confirms the above values.²⁸

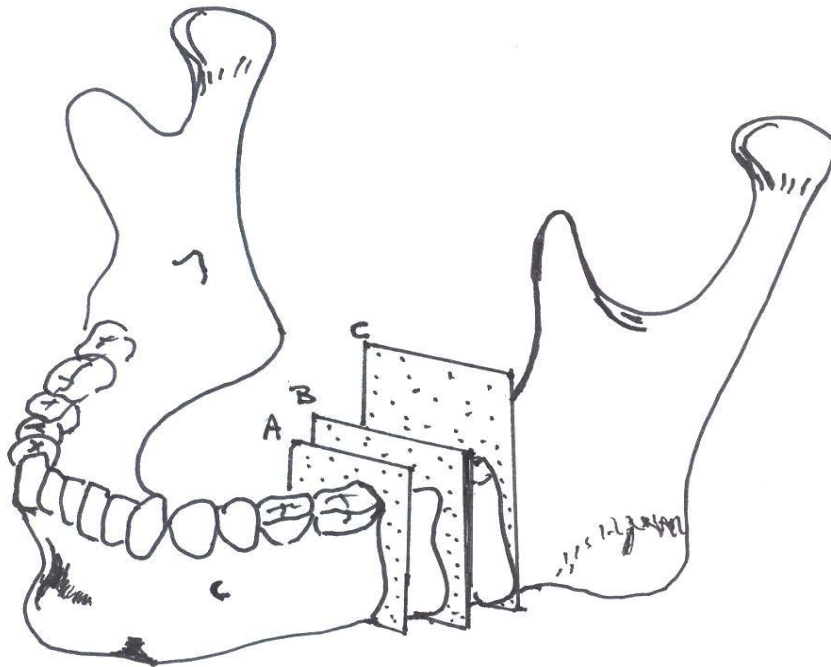

Figure 10: Section A- Distal root of the second molar. Section B- Distal root of 3rd molar. Section C- Just posterior of the third molar tooth and the anterior border of the ramus

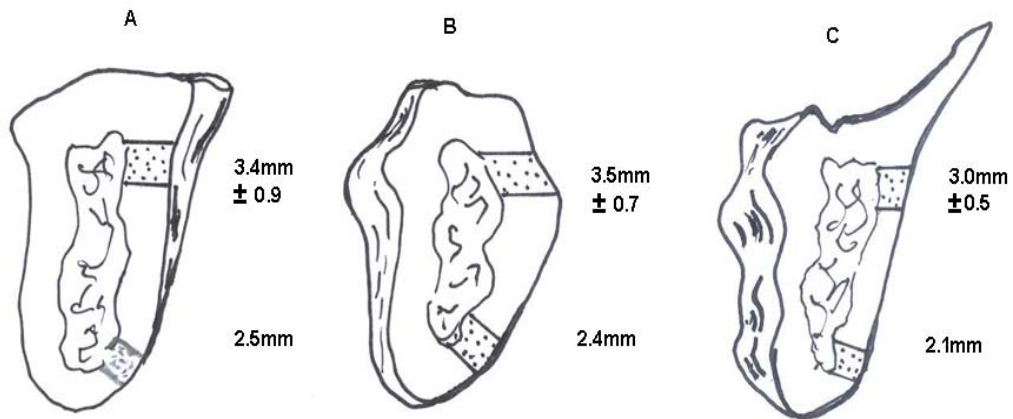

Figure 11: Cortical thickness at different sections A, B and C related to the mandibular angle region

2.5.2 Thickness of the mandible as applicable in a bi-cortical fixation

The total thickness of the mandible at the external oblique ridge and at 5mm above the inferior border is compared in Table 1.

Section	Vertical location	Minimum	Maximum	Mean	S/D P
A	External oblique ridge	7.0	16.4	13.8	2.0 < .00
	5mm above inferior border	5.4	12.3	9.5	1.2 < .00
B	External oblique ridge	11.6	16.9	14.9	1.4 < .00
	5mm above inferior border	4.0	11.8	8.0	1.5 < .00
C	External oblique ridge	8.0	17.8	13.3	2.0 < .00
	5mm above inferior border	3.3	8.9	6.4	1.3 < .00

The mandible is significantly thicker in the retro-molar region at the external oblique ridge (mean, 13.3 to 14.0mm) than at 5mm above the inferior border (mean, 6.4 to 9.5mm).

2.5.3 Position of the Neuro-Vascular Bundle

Data from anatomical studies indicate that the minimal distance from the inferior aspect of the inferior alveolar canal to the inferior border of the mandible is approximately 5.0mm. The mean distance at the second molar has been found to be 8.3mm and 8.9mm for the third molar region.

If cortical penetration (cutting) is performed just medially to the external oblique ridge, the vertical distance between the most superior aspect of the canal and the cortex will be 6.9mm in the second molar, 10.9mm in the third molar, and 13.9mm in the most anterior symphysis region of the ramus.

2.6 Surgical Approach and Clinical Relevance to Screw Angle Application

2.6.1 Trans-buccal/ per-cutaneous surgical approach for screw systems at 90° to the bone plate surface

A distinct disadvantage of rectangular screw plating in the mandible angle is related to the plate placement on the bucco-lateral aspect. This requires a trans-buccal approach (an approach through the cheek, skin, muscle and periosteum) with the use of a trochar in order to be able to place the screws at right angles (90°) to the plates, as illustrated in Figure 7. Trans-buccal trochar screw placement is required for plates placed buccal or inferior to the external oblique line. Special factors are therefore to be considered according to the fracture site. In certain cases, to ensure avoidance of tooth apices and mental nerve compression by the plate, it may be useful to lower the foramen by making a vertical slot from the inferior dental foramen and set the nerve inferiorly.

In front of the mandibular foramen or, accurately, in front of the canine, two malleable plates, 4.5mm apart, are required to prevent torsion moments. The inferior plate is inserted first, then the sub-apical one. In the horizontal ramus, behind the mental foramen, one sub-apical plate is quite sufficient. The osteosynthesis should be done at higher level the more posterior the fracture is located. For osteosynthesis at the angle, it is known that for several years have used the vestibular osseous flat area located beside the third molar as the osteosynthesis site has been used; that is a

genuine ridge made by the external oblique ridge. The plates are located in a frontal plane and the screws positioned in a sagittal direction. When this area cannot be employed (to narrow a ridge, impacted mandibular third molar, alveolar fracture too young a subject) the plate should be applied as high as possible, on the lateral surface of the mandible using the trans-buccal technique. Even in the most difficult cases, a skin incision is unnecessary. After exposure of the angle through the intra-oral approach, the cheek is transfixed with a needle and the osteosynthesis area is determined (as high as possible). The skin is then punctured and penetration of the musculo-aponeurotic tissue is achieved by means of the trochar provided with its guide. The stiletto is now withdrawn from the trochar and the guide is screwed on the retractor with lighting introduced through the buccal approach. The screw-holding screw-driver then enables screw fixation via the transbuccal guide. At the University of Pretoria, the transbuccal method was used in approximately 20% of the cases of osteosynthesis at the angle.

Plates placed in close proximity to these lines produce optimal stability. Note that there are two possible locations for plate placement around the angle within the sympheseal or para-sympheseal areas Champy³ stressed the need for two plates to counter increased torsional forces.

Studies have shown the possibility of a number of complications. Percutaneous instrumentation can cause a haematoma, false aneurysms, nerve involvement, longer operating time, skin scarring and, furthermore, complicated extended operation time in removing of such plating systems. Higher operating cost due to more time spent has been estimated to add additional operating time of approximately 21 minutes.^{16, 29}

Placement of two-plate fixation is more time-consuming and the trans-buccal use of a trochar, which contributes to extended operation time, resulting in longer exposure time of bone to a higher bacterial contamination. Loss of a screw during the surgical procedure, introduced through the trochar, results in extended operating time, as it might have to be retrieved from a tissue plane.

Percutaneous instrumentation is also essential when applying the mono-cortical strut plate system (used to provide increased strength) at the angle of the mandible.³⁰ The angle of the mandible demonstrates inferior narrowing and the location of a third molar, as an impaction or un-erupted tooth, has a major impact on stabilisation of a fracture. Due to the biomechanics of the mandible, these fractures are associated with the highest incidence of post-surgical complications.

2.7 Screw Angle Comparative Biomechanical Stability Pilot Studies

The biomechanical behaviour of a mono-cortical angled plate hole system has never been compared to conventional rectangular 90° placement for degrees of 75°, 60° and 45°. The plate design for this *in vitro* study has 2mm profile and dedicated screw holes machined at angles of 90°, 75°, 60° and 45°. The plating system can be applied mono-cortically at the infero-lateral aspect of the external oblique line to coincide with the thick cortical area also to be placed with known functional tensile strain lines and according to the second Champy line for ideal osteosynthesis in the angle of the mandible (Figure 12).

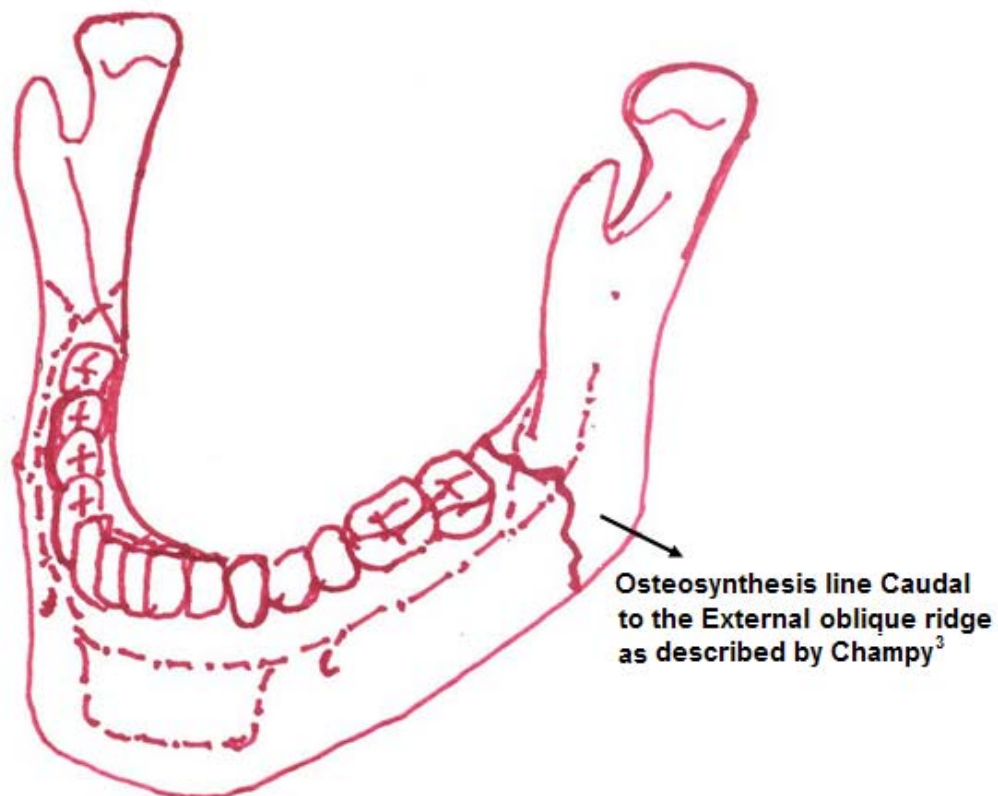

Figure 12: Depiction of Champy's ideal lines of osteosynthesis

Investigating the biomechanical stability behaviour of angled screw application in a mono-cortical fashion would clarify its clinical relevance in view of:

- limited biomechanical stability information available,
- fixation criteria applicable for ISI in mandibular fractures.

The major advantages in its use would be intra-oral minimal invasive application (restricted only by specific anatomical regions with limited access due to tissue tension). A direct line of vision during application simplifies technique for intra- or extra-oral surgical technique.

Bi-cortical angled (60°) intra-oral insertion of screws of 2mm diameter can be used in the rigid fixation of mandibular sagittal split ramus osteotomies³¹. No significant difference on the stability was noticed between screws placed 60° or 90° to the long axis of bone for both *in vitro*³² and *in vivo* application (Figure 13).

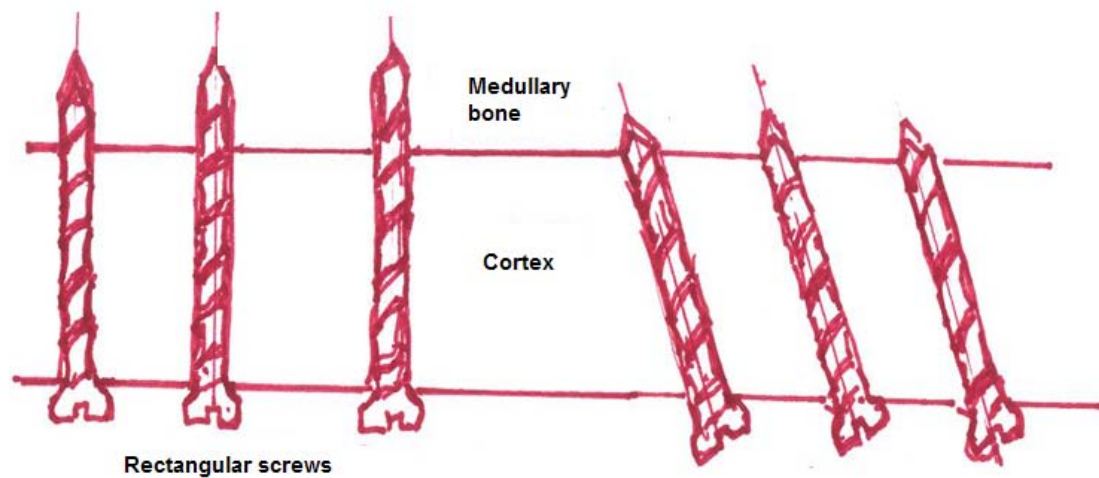

Figure 13: Illustration of cortex transacted with rectangular and inclined screw placement (Also see Figure 40)

It is postulated that screws inserted at 60° have a longer area of contact in the bone cortex. For the same length of screw more cortex can be transacted without having threads in medullary bone – longer screw travel at an angle of <90°, and therefore longer screws, can be used clinically to benefit three-dimensional stability.

For the same length of screw more cortex can be transacted and if angulated, less screw thread is present in medullary bone. Intra-oral screw placement for fixation of the angle of the mandible is the preferred surgical technique. However, 90° screw surgical placement usually requires an extra-oral approach.

The plates for rigid internal mono-cortical fixation of mandibular fractures all have plate holes orientated 90° to the long-axis of the plate. The slanted-screw plate designed by Krenkel²⁴ with transverse holes would accommodate screws placed at

angles 30° to 90° to the long axis of bone to facilitate placement intra-orally to the dorsal border of the mandibular ramus.

In this research investigation of screw angle placements for angles 30° to 90° it was proven that a screw at 30°-angle to the long axis of a plate would perforate cortex and travel parallel to the under surface of a plate. This would result in “lifting” the plate from the bone surface. The screw angle at 30° was confirmed by CAD drawing to be clinically unsound.

Biomechanical stability in vitro pilot studies were conducted to express feasibility and an anatomical cadaver study completed to establish clinical relevance of the angled screw application specifically for the application to the lateral aspect of the external oblique line as illustrated in Figure 14.

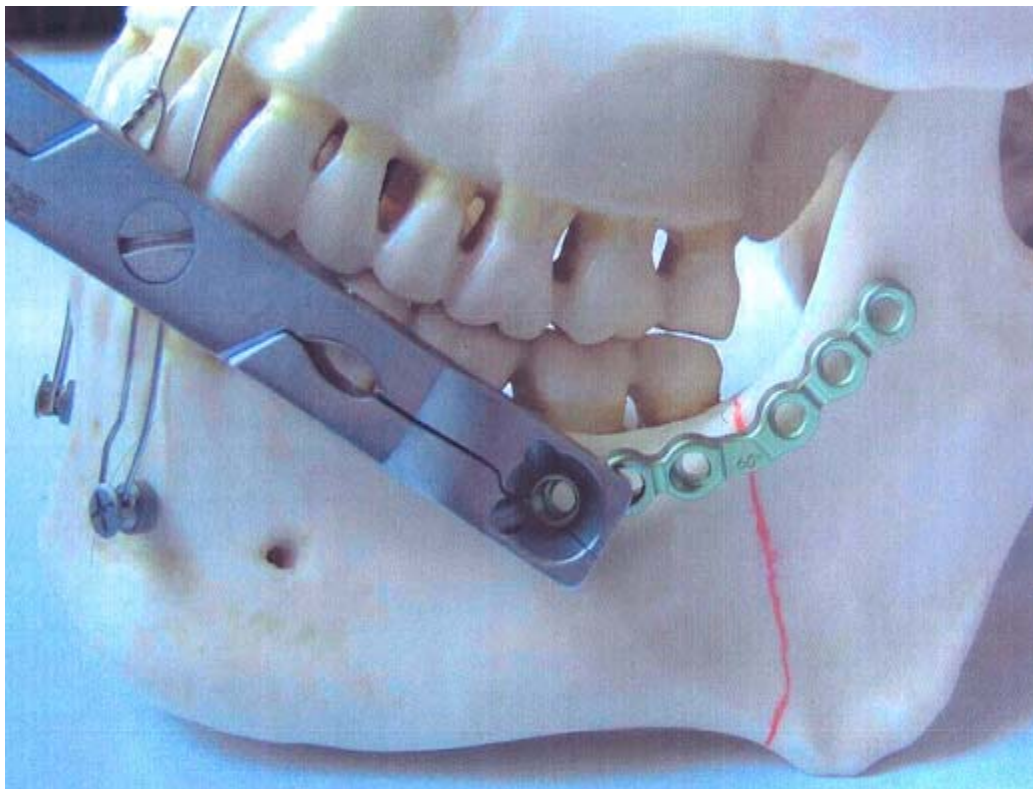

Figure 14: Inclined Screw Insertion (ISI) plate holes

The pilot study was considered for investigation and presented to the Centre for Integrated Sensing Systems as a project proposal: “Pilot study on mono-cortical systems used in mandible fractures” (ISP (2002) IC 036). The CSIR outlined conditions for the proposed project on 01/07/2002, which was unacceptable with

regard to the intellectual property claim made by the CSIR (Addendum 1). It was decided to design and manufacture for this research a unique jig and biomechanical testing device for application in the Instron meter at the Centre of Stomatological Studies, School of Dentistry, University of Pretoria: “Protocol entitled – The effect of innovative screw angled mini-plates on biomechanical stability of monocortical fixation – an in vitro model.” (Addendum 2).

This initial study was completed prior to January 2003 and the results indicated no significant difference between rectangular and 60° degree angled screw placement with regard to compression testing – this prompted further investigation to compare the same in a load bearing situation (Figures 1 to 3).

The superior biomechanical stability for load bearing biomechanical stability for the 60°-angled screw system supported further investigation leading to this PhD protocol. The results of this first pilot study were reported at the facial trauma clinic “Where First and Third Worlds Meet” presented by the Division of Maxillo-Facial and Oral Surgery, University of the Witwatersrand, Johannesburg in February 2003. These results were presented during an oral presentation with title: “Mono-cortical management of mandibular fractures”.

An unique 6-hole titanium fracture plate for mono-cortical management of mandibular angle fractures with plate holes at 60° angles was prototyped based on above pilot studies and presented as a paper under the title: “The Minimal Invasive Mono-Cortical Angle System (MIMAS)” at the 16th International Conference on Oral and Maxillofacial Surgery, Athens, Greece in 2003²⁶. The distinct advantage being angled screw placement permitting intra-oral application of a plate to the lateral aspect of the external oblique line without trochar transbuccal (cutaneous) application required for conventional rectangular screw application.

CHAPTER 3 PROBLEM AND PURPOSE OF THE *IN VITRO* STUDY

3.1 Statement on the problem and purpose of the *in vitro* study

The purpose of this study is to introduce a testing device and a scientifically relevant method of investigating the biomechanical behaviour of mono-cortical mandibular fragment fixation at different screw angles - a concept completely original and unique in its application with distinct clinical relevance.

- The development and fabrication of a testing device to evaluate three-dimensional *in vitro* stability of mini-plate fixation of the mandible which emulates clinical relevance.
- To determine and quantify the efficacy of biomechanical stability of mono-cortical fixation employing mini-plates-inclined screw insertion (ISI) plates, designed to accommodate a screw-placement angle of 90° (control) and design innovations featuring screw-placement angles of 45°, 60° and 75° respectively. These fixation displacement characteristics will be assessed in tension, compression and torque modes of loading.
- To compare and reflect significant differences in the flexural data obtained from the various fixation systems.

Mini-plate fixation techniques, without inter-maxillary fixation, evolved as a consequence of the delineation of the intrinsic anatomy and biomechanical principles associated with deformation of the mandible in function.

The development and construction of the cantilever/torsion testing device should simplify technically challenging procedures presently employed for accurate assessment of biomechanical stability of mandibular fixation systems. Significant clinical relevance will be expressed by applying known bite force values related to operated individuals. The efficacy of biomechanical stability of mono-cortical fixation, when subjected to tensile, compressive and torsional modes of loading, should exhibit similar load displacement characteristics for both the conventional 90°, and the experimental screw plate designs featuring more acute placement angulations.³²

The preceding résumé of the literature indicates an awareness of the factors that influence the prognosis of mandibular fracture fixation. In general, these factors are related to three areas:

- (i) anatomical and surgical constraints,
- (ii) analytical investigations of the biomechanical behaviour of the mandible and
- (iii) biomechanical design and location of the fixation system

While the first area has enjoyed extensive investigation, the second area, which has to do with prediction of functional stability, is subject to complicated analytical methodology. The third area, which concerns the design and location of the fixation systems, is extensively but inconclusively reviewed. Very little attention has been given to:

- (i) the development of less complicated methods for delineating the biomechanical behaviour of the mandible for functional stability determination of fracture fixation,
- (ii) the problem of anatomical positioning of the plating system to ensure a minimal invasive surgical technique and cost effective operating time,
- (iii) the introduction of new geometric plate designs according to and coinciding with known strain lines of the mandibular during function,
- (iv) the design aspects of a specific plate to acquire functional stability by means of a single plate, rather than a combination of straight plates, and
- (v) the relationship between biomechanical stability and the screw placement angle in mono-cortical fixation.

Since the prognosis of mandibular angle fractures osteosynthesis segments are dependent on the post-operative stability of the displaced segments, there is a need for detailed consideration of the fixation characteristics of ISI (Inclined Screw Insertion) mini-plate designs to simplify lateral plating of the ramus through intra-oral, direct line of sight, surgical technique.

CHAPTER 4 EXPERIMENTAL PROCEDURES

The materials and methods used during this study will be documented in sections, which are broadly co-incide with the lines of the investigation followed.

4.1 The Biomechanical Testing Device

The *in vitro* study was conducted using a unique, own design and manufactured jig for the purpose of compression, tension and torsion force delivery to polyurethane synthetic hemi-mandibles. The jig (Figure 15) is designed with base plates mounting it to the 2010 Zwick testing machine (Ulm, Germany). The base of the jig is slotted and allows sliding adjustment of the platform, to align the fixated test model within the 2010 Zwick Testing machine to the load-pin for delivery of either (i) compression, tension force in a downward motion or (ii) rotation – torsion force in an upward motion via the cable wheel (Figure 16).

4.2 Tension/ Compression Evaluation

The jig basically consists of two testing platforms. The one platform features a fixed vertical mounting plate for stabilising the experimental model in order to perform load-deflection by application of specific load at a standardised predetermined distance from the osetomy site.

The vertical load induced via the load-pin as illustrated in Figure 17 in the Zwick machine, facilitates determination of the tensile and compressive (cantilever) displacement that occurs within the fixated test samples. All measuring was performed by the same operator.

The three-dimensional stability testing device that will be used for the stability potential evaluation of the fixated test module, involves the incorporation of the test jig, as shown in Figure 18 within the Z010 Zwick testing machine. The load cell 50N type 8301 (seen just above the mounted base and load-pin in Figure 18) has a 50N limit.

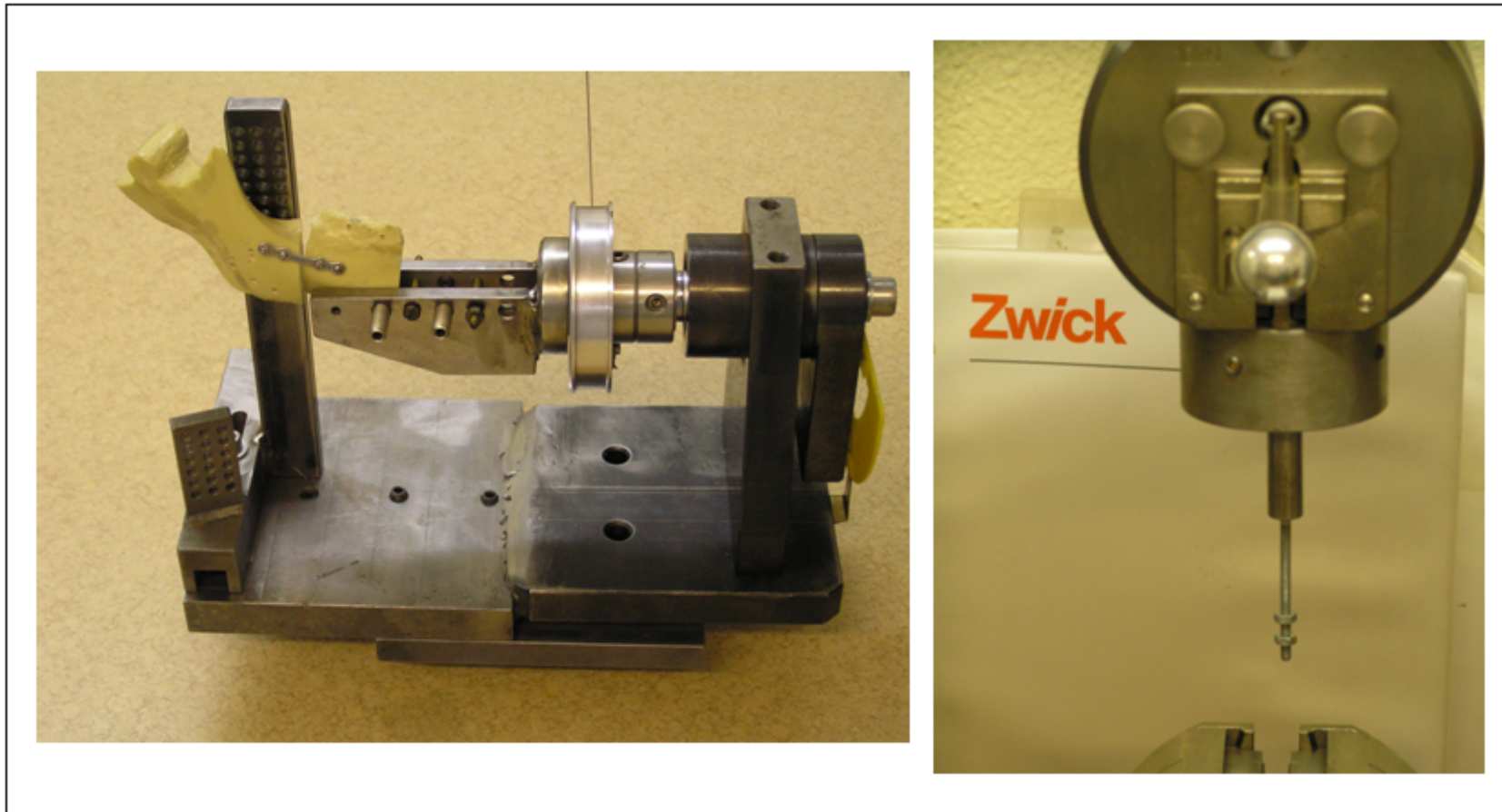

Figure 16: Actual testing device testing via cable on left and compression testing via load-pin on the right

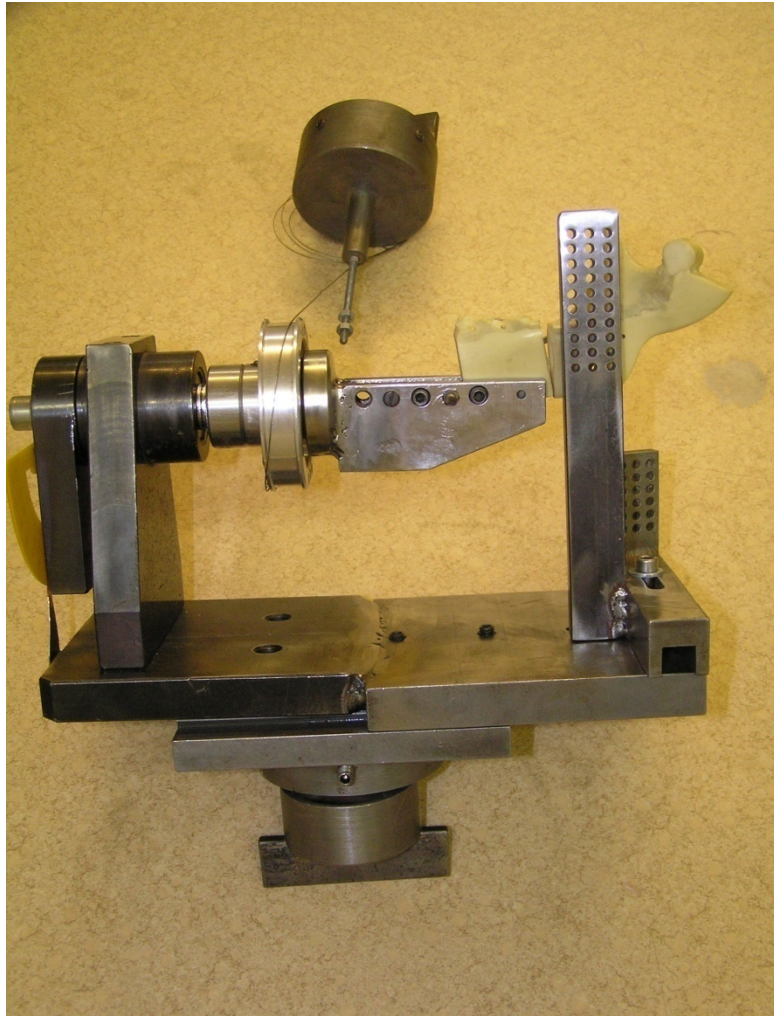

Figure 17: Load-pin experimental set-up

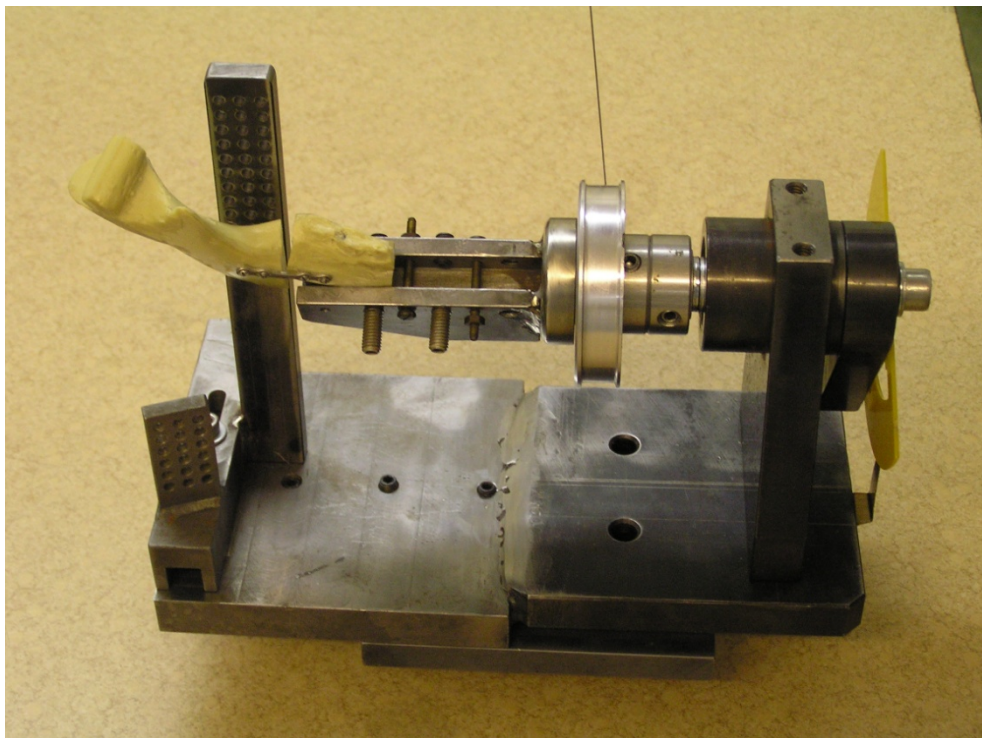

Figure 18: Test jig within the Zwick machine



Figure 19: Load cell of 50N type 8301

The upward motion delivered by the Zwick machine at a constant crosshead speed of 0,25mm/min will result in rotation of the wheel and apply a torsion force to the polyurethane test model. A downward crosshead speed will deliver a compression force to the distal fragment of the proximal distal fragment of osteotomised synthetic mandible as shown in (Figures 20 and 21).

All mandibles will be rigidly mounted to the vertical section of the base-plate allowing free movement of the distal segment when load forces via the load pin modification in the Zwick machine (Figure 21). Delivered load pin compression/tension force is applied to a prepared fossa in the occlusal surface of the first molar.

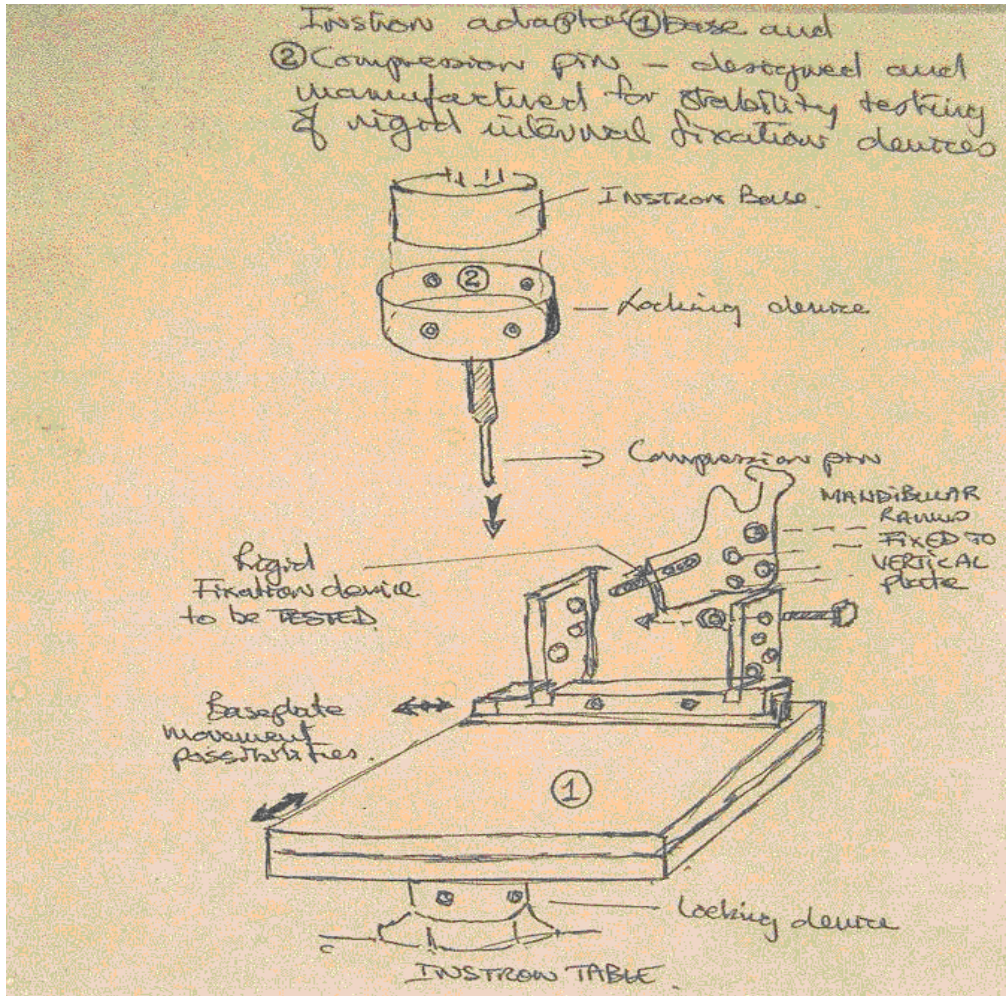

Figure 20: Design sketch of test model with mounting base for compression testing in the Zwick machine

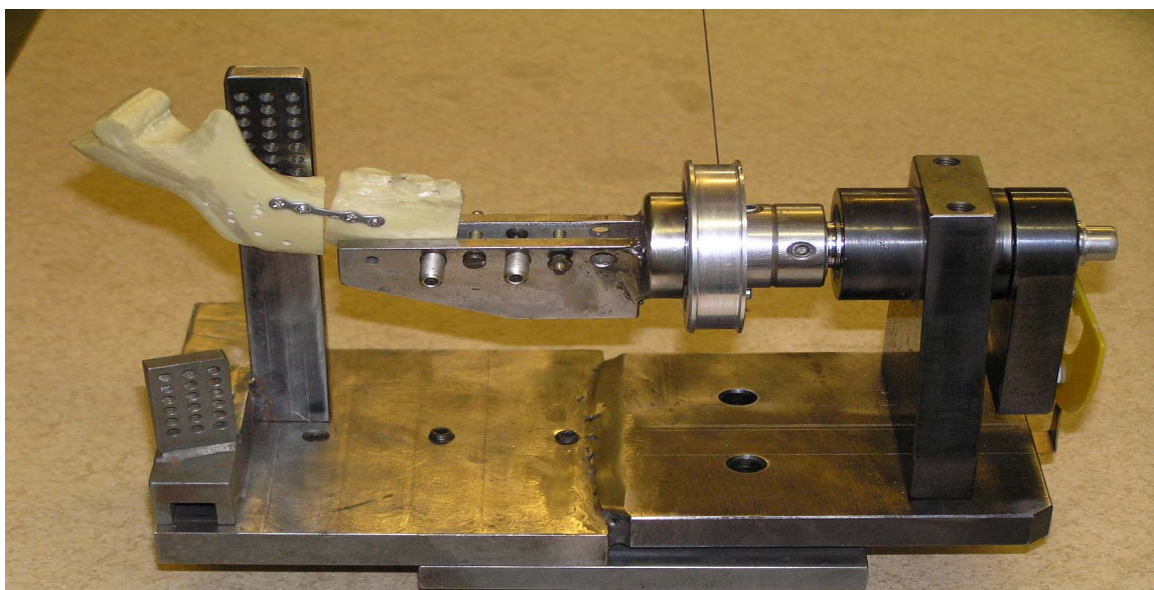

Figure 21: Photograph of three-dimensional experimental jig with fixated test module

4.3 Torque Evaluation

The second platform of the test jig consists of a rotating model holding device. This device features a round disc 4cm in diameter, located on a horizontal rotational axis with a wound steel cable with a tensile breaking force of 500 Newton. One end of the cable is fixed to the disc and the other end is attachable to the load-pin of the Zwick machine. Specific load application by the Zwick machine on the wound cable induces shear deformation on the experimental model. Torsional loads are obtained by value substitution in the following formula:³³

$$D = F \times r$$

where $D = \text{Torque (Nm)}$

$F = \text{Tensile Force (N)}$

and $r = \text{radius of disc (mm)}$

The experimental validity of this formula is dependent on a constant radius. This is achieved and controlled by maintaining a constant cable to wheel angle during application and relaxing of the load.

In addition, a scale of degrees is secured to the rotating axis of the wheel to record the degrees of rotation in response to torsion loading of the model as shown in Figure 22.

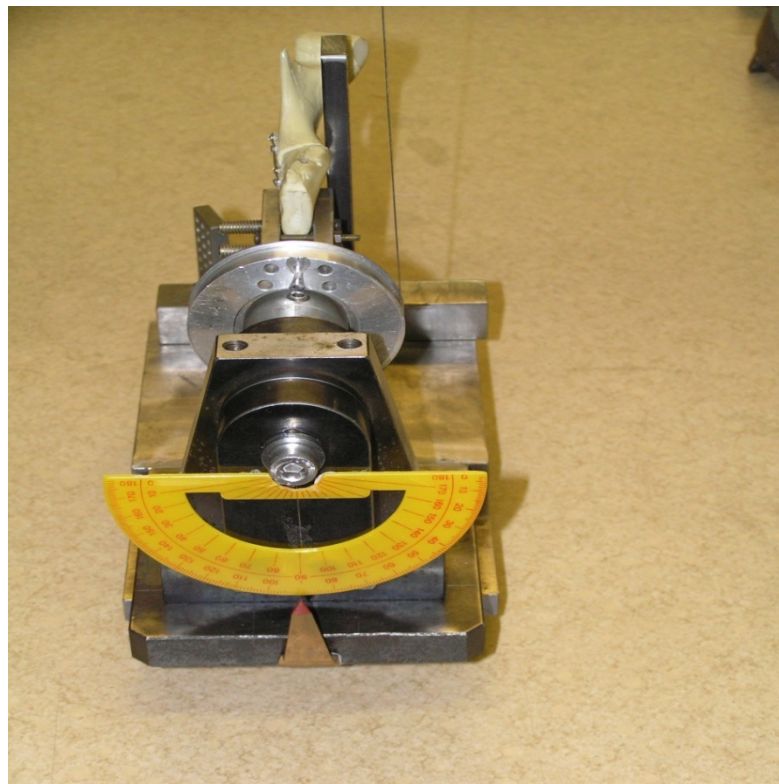

Figure 22: Device used for measuring the degrees of rotation at specific torque applications

Physical displacement of the segments (gapping) was obtained from the load-displacement as computerised data obtained from the Zwick machine drawn as a graph for both the compression and torsion test modules and registered.

The relationship between gap widths and incremental torque or compression values was documented and used to produce graphic linear regression models for both face applications. Rotation was expressed as a degree of rotation to Newton torque.

4.4 Compilation of Mandible Samples

A total of 60 polyurethane synthetic mandible replicas (Synbone, Landquart, Switzerland) were used in this study. These synthetic replica mandibles simulate the human mandible by demonstrating a rigid outer cortex and softer medulla component as demonstrated in Figure 23.

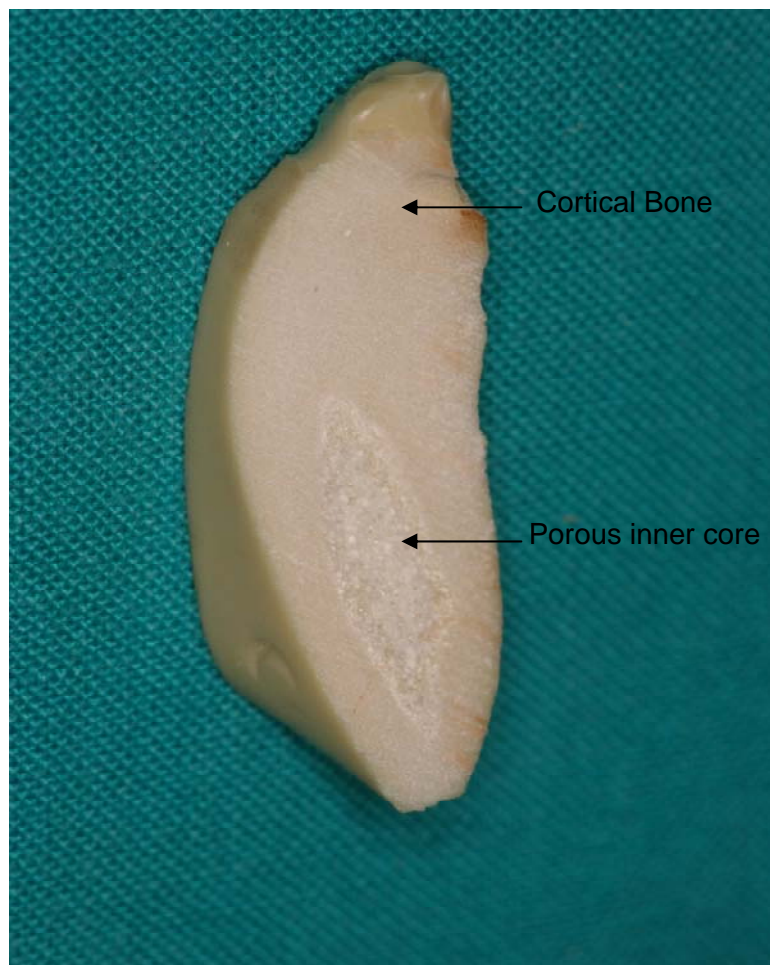

Figure 23: Polyurethane replicas with outer dense layer and porous inner core

This uniformity allows for more reliable comparison of fixation techniques by eliminating the variability normally seen in cadaveric and sheep mandibles.^{33, 34} The specimens were sectioned in the midline to produce 120 hemi-mandibles for evaluation (Figure 24).



Figure 24: Hemi-mandibles for evaluation

These samples were divided into four categories with 15 specimens in each category. The different fixation categories consisted of:

- mini-plate with 90° screw placement angle,
- mini-plate with 75° screw placement angle,
- mini-plate with 60° screw placement angle, and
- mini-plate with 45° screw placement angle.

These categories will be further subdivided into two different groups, each comprising 15 samples for the three-dimensional fixation stability evaluation. The modes of loading to determine biomechanical stability, in the developed test jig for each group, are the following:

- tension and compression evaluation, and
- torque evaluation.

All mandible models were sectioned at the angle, using a reciprocating saw with blade profile of 0.9mm and segmentation template to standardise the exact site and resection width at all mandible angles. An oblique cut, simulating a vertically and horizontally unfavourable fracture line, was performed to create clinical relevance to unstable proximal fracture segments.

The elastic modulus of polymethane is 10 times less than in normal human bone and has clinical relevance. Exact rigid fixation and alignment of the osteotomised proximal and distal segments is ensured using the mini-plate positioning template.

4.5 Fabrication of Positioning Templates

An intact hemi-mandible was used for the fabrication of the polymethylmethacrylate (PMMA) localisation templates required for standardised and chronological preparation of the test samples and positioning of these samples in the mechanical testing device as follows:

4.5.1 Mini-plate positioning template

The template for standardised mini-plate localisation on the ventral aspect of the external oblique ridge is designed to accommodate two different plate positions in close proximity to one another. The upper position will be employed for tension/compression evaluation whereas torque will be derived from the inferiorly located structure (Figure 25).

This approach is primarily a cost-saving exercise which is unlikely to compromise biomechanical principles. In addition, the screw access holes on the various mini-plates will have drill guides for accurate angular preparation and predetermined depth penetration for the fixation screws.



Figure 25: Upper and lower plate positions

4.5.2 Segmentation template

The segmentation template incorporates a guide groove for the introduction of standardised horizontally and vertically unfavourable osteotomy at the angles of the replica hemi-mandibles (Figure 26).



Figure 26: Upper- and lower notches for segmentation alignment

The template will feature two corresponding and linearly aligned bi-cortical engaging guiding trenches, $\pm 5\text{mm}$ in length located on the upper and lower aspects of the template allowing orientation slots to be cut into the surface of the synthetic mandibles. Standardised sectioning will be obtained by linear connection of the prepared slots after removal of the template and by employing a reciprocating saw with a blade width of 0,9mm for segmentation.

4.6 Mini-Plate Fixation Procedures

The osteotomised segments were connected (fixated) by means of the experimentally designed and prefabricated titanium six-hole curved mono-cortical fixation plates identical in profile (Stryker/Liebinger, Freiburg, Germany) as illustrated in Figure 26.

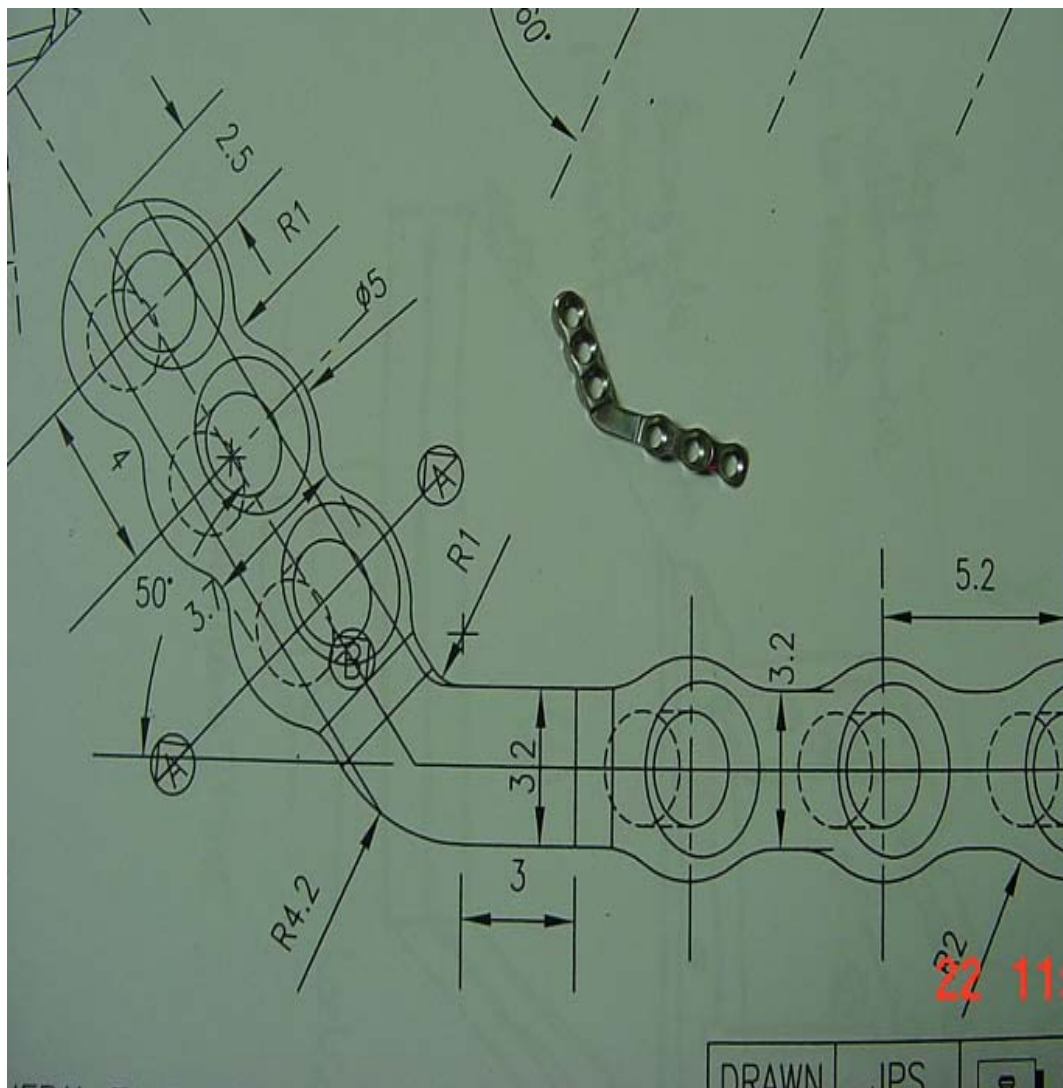

Figure 27: A curved mini-plate illustrating ISI (Inclined Screw Insertion) with plate holes at 90°, 60° 45° or 75

These mono-cortical plates have plate holes at 90°, 75°, 60° and 45° to the plate surface and are 2mm thick in profile. One hundred and twenty plates were used in total, 15 in each angle category for the biomechanical evaluation of the two groups of compression and torsion.

Dedicated drill guides were manufactured one each at angles 90°, 75°, 60° and 45° and used to ensure an exact angle for pilot drilling with 1.5mm drill prior to standard identical 7mm screws of 2mm diameter placement (Figure 28 and 29).

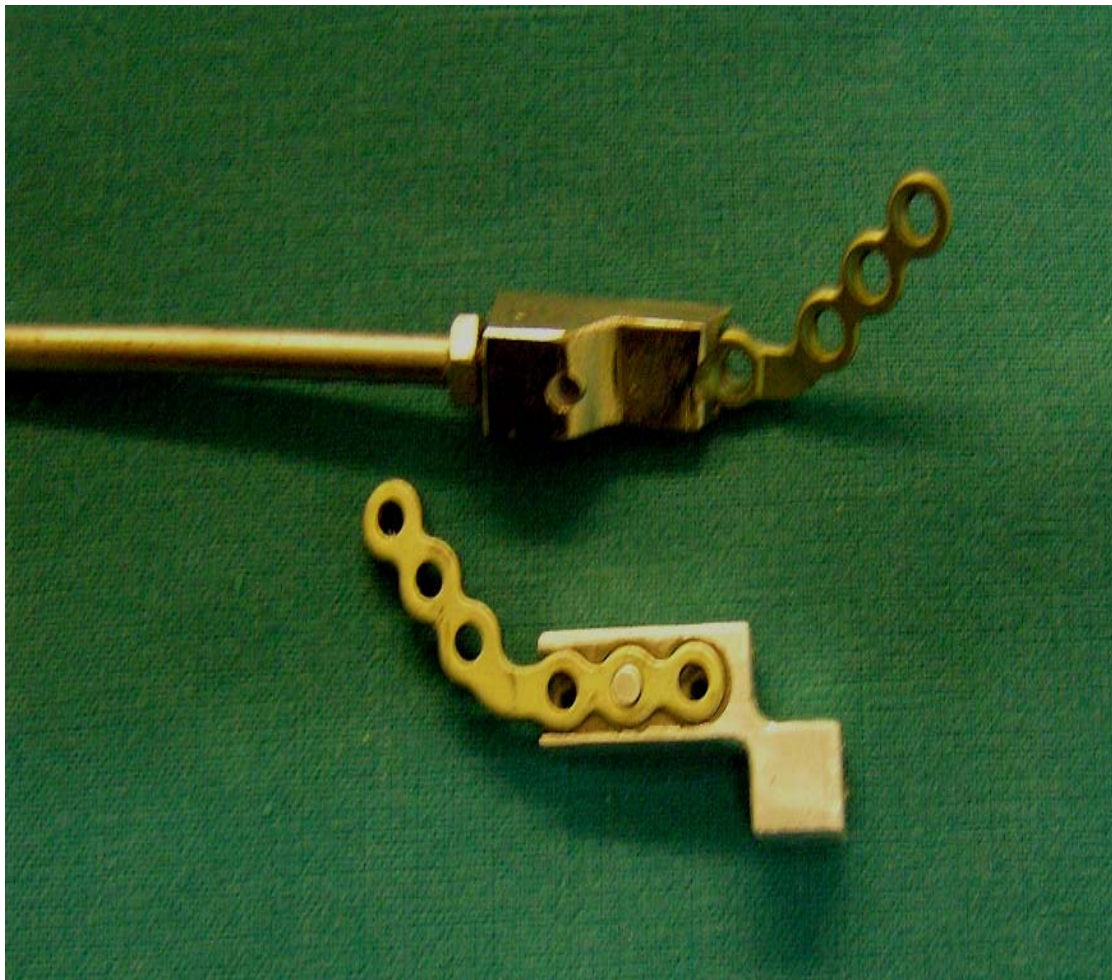

Figure 28: Dedicated drill guides

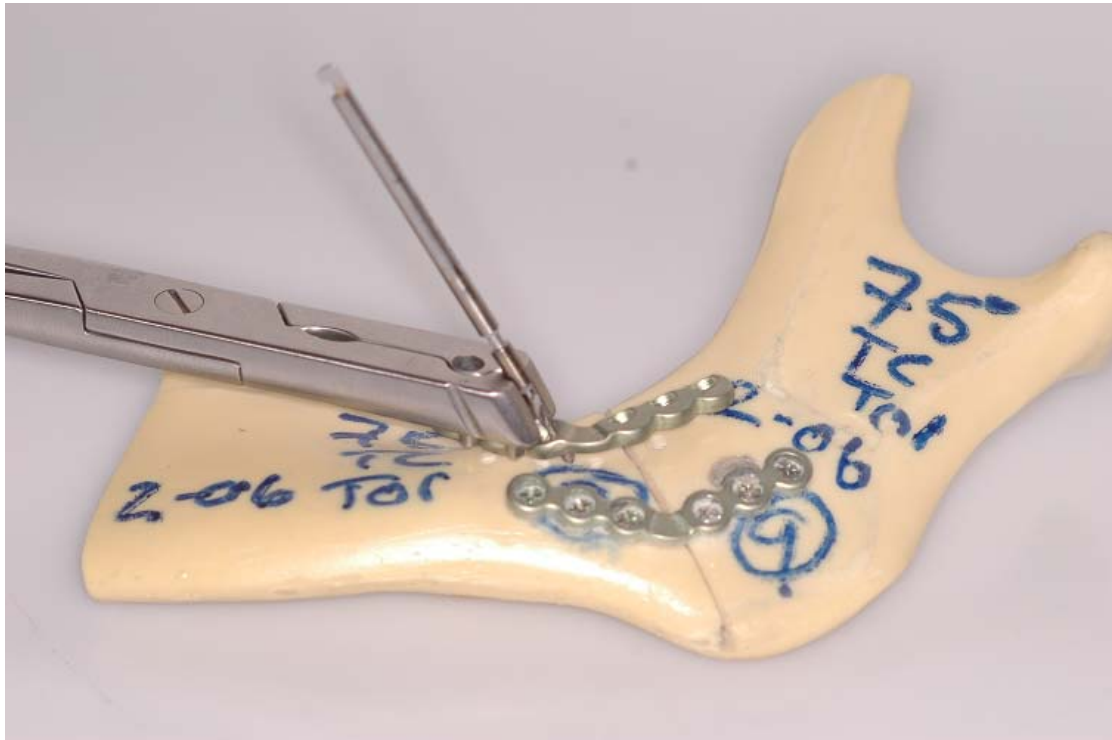

Figure 29: Pilot drilling with aid of drill guide

The different mini-plates were positioned and held in position by the preformed positioning templates prepared screw holes and each screw tightened to predetermined standardised interfacial pre-loads using the calibrated torque screwdriver (Figure 30).



Figure 30: Calibrated torque screwdriver, pre-set at 40 N/cm together with a certificate of calibration

The completion of preparative procedures on the hemi-mandibles necessitated accurate localisation and fixation of each individual test specimen in the testing device for three-dimensional flexural load-displacement evaluation.

4.7 Load Displacement Evaluation

All the load displacement tests were conducted in the Zwick machine. The experimental jig with the mounted test models were incorporated within the testing machine by means of adaptor plates. The resistance to the applied tensile, compressive and shear loads was regulated. A progressive load up to a maximum of 35 Newton was applied to simulate clinical conditions. One Newton in the test machine is equal to 10 Newton clinically.

These loading parameters are clinically relevant and based on studies of bite force measurements in postoperative patients. The assumption made is that meaningful information regarding mechanical behaviour was obtained within the 0-300 Newton range which is clinically significant for incisal edge loading and 0 to 200 Newton range for contra-lateral loading.

The velocity of the crosshead travel was regulated at 0,25mm/min. Furthermore, a tension-compression load cell of 50N capacity was calibrated and used throughout this investigation (Figure 19). Before each test, the experimental jig containing the test model was secured to the lower base of the Zwick machine and calibrated to obtain a zero deflection value on the chart recorder. The load displacement characteristics were recorded on the computerised chart recorder. From the known deflection values on the chart recorder, it was possible to derive the stability values of each fixation design relative to the magnitude of the applied load.

Before experimental stability determination of the prepared test models, five unprepared intact hemi-mandibles were used as controls to define the limitations of the substrate (synthetic mandible replicas) and testing jig.

Incremental load displacement testing with zero, five, fifteen, twenty-five and thirty-five Newton were conducted to determine the stability of fixated test samples for two modes of load applications, tested as tension/compression and torsion.

Furthermore, the amount of physical displacement of segments (gapping) that occurred during the two modes of loading was obtained as load displacement graphs.

For the purpose of interpreting the comparative results, all variables were standardised e.g. screw lengths, torque and diameter. Curved mini-plates with a profile of 2mm, and angled screw holes machined at 90°, 75°, 65° and 45° were designed, manufactured, intended for mono-cortical fixation and bridging of the sectioned polyurethane mandibles as in figure 31.

The ISI mono-cortical titanium plates differed only in angle of screw holes 90°, 75°, 60° or 45° angles (Figure 31)

The ISI plates were precisely positioned, prior to fixation, using a positioning template for either compression screw angle testing (CSAT) or torsion screw angle testing (TSAT). The gold standard for the comparative, compression/torsion biomechanical testing of the ISI (Inclined Screw Insertion) was the conventional rectangular (90°) screw placement.

The pilot drill within the inclined screw hole of the ISI plate demonstrates the 45° angle of the plate hole where the plate profile is 2mm to accommodate this dedicated angled plate-hole (Figure 32).

Biomechanical evaluation of angled screw fixation when applied as a mono-cortical plating system at the lateral aspect of the mandibular angle (according to the Champy, ideal line for osteosynthesis) has never been investigated before and is expected to yield meaningful information with high clinical relevance as a system that can be applied via intra-oral surgical technique (Figure 12). Screw lagging across the fracture line and longer screw application as a result of angulation is predicted and would result in superior biomechanical stability if compared to conventional 90° screw placement.

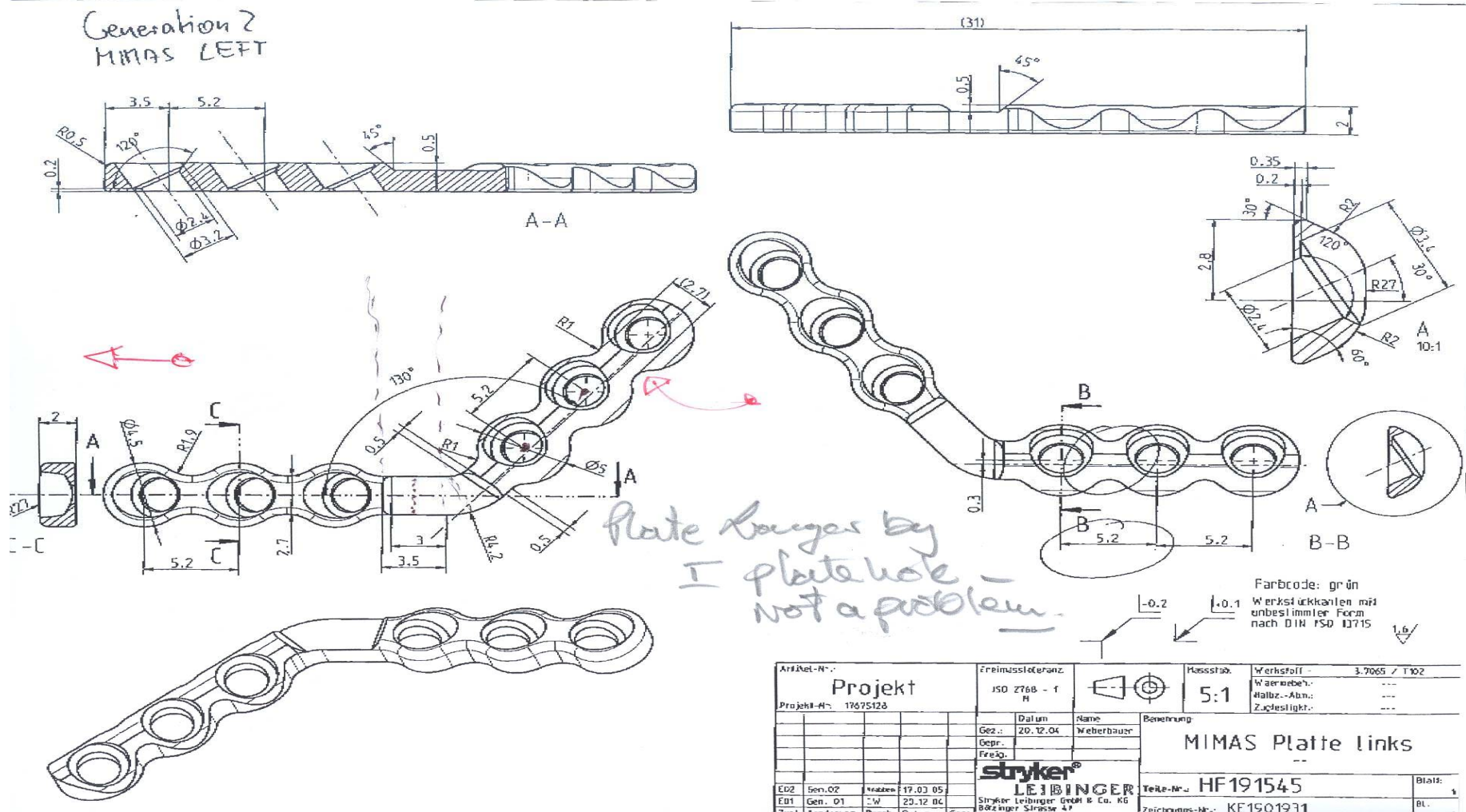

Figure 31: Design sketches for angle screw holes in L-shaped (ISI) mini-plates

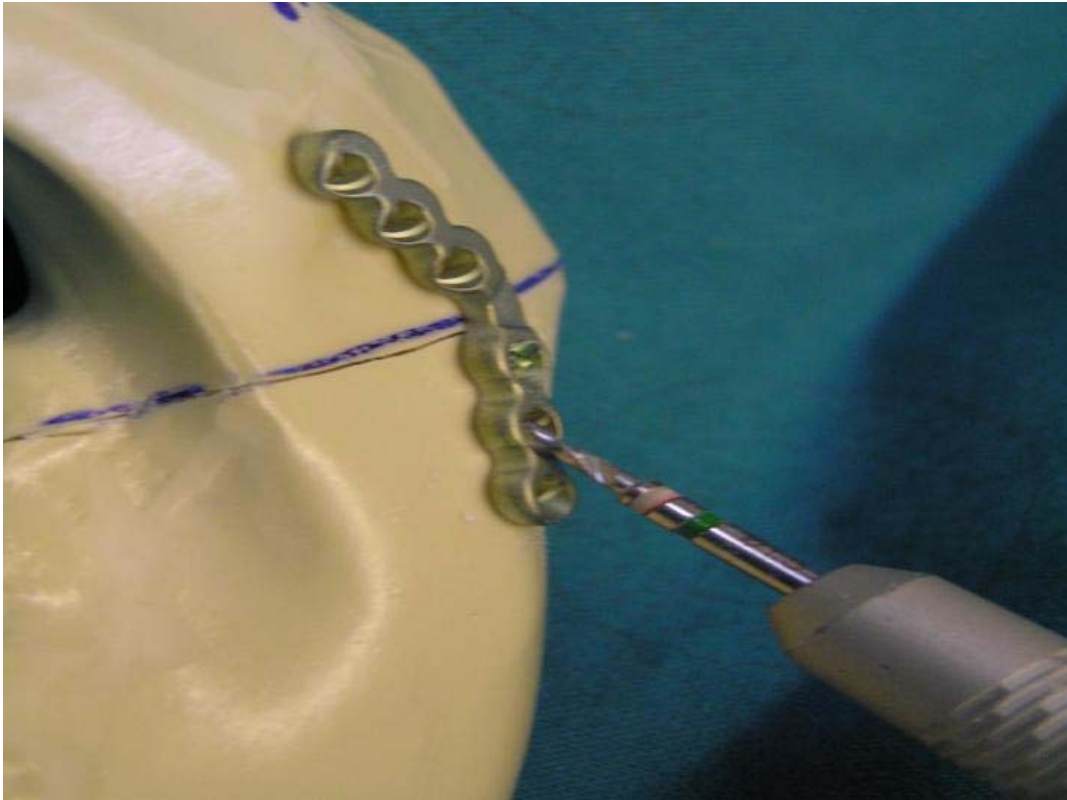

Figure 32: Pilot-drill, used to demonstrate the angled screw-holes in ISI plate

CHAPTER 5 RESULTS

5.1 Biomechanical Testing Device

The design and construction of this device proved to be compatible for use in the Zwick testing machine. The device also facilitated a simple but extremely effective and scientifically reliable method for investigating the three-dimensional load-displacement properties of fracture stabilisation in synthetic mandibles.

All the load-displacement data obtained using the biomechanical testing device secured in the Zwick machine, showed small fluctuations in the initial phase of load application. This was ascribed to settling of the rounded compression pin in the prepared fossa of the occlusal surface of the first molar tooth in the test model. In order to standardise the measurements for each variable, the force resistance zero point was taken as the point when this fluctuation is stopped and a constant increase in force delivery was observed. This meant that measurement of placement or extension of the mandible only started at the point when there was a constant increase in force delivery.

5.2 Compression Load-Displacement Results

Fifteen compression test samples registered force delivery values at increments of 0.1mm displacement for each of the screw angle applications 90°, 75°, 60° and 45°, the failure point was arbitrarily set at 3.0mm displacement to reflect clinical inability for primary healing of fracture fragments. The load-pin delivered a compression force at a constant crosshead speed 0.1mm/min and the test sample terminated at a displacement of 5mm.

The recorded load-displacement data of the individual screw angle applications are listed in Table 2.

Table 2: Load-displacement values in compression for screws placed at 90°, 75°, 60° and 45° respectively

Displacement (mm)	Screw Angle (Degrees)	Load (Newton)
0.1	90	0.79
	75	0.58
	60	1.02
	45	0.85
0.2	90	1.54
	75	1.17
	60	1.96
	45	1.92
0.3	90	2.18
	75	1.74
	60	2.88
	45	2.65
0.4	90	2.73
	75	2.28
	60	3.17
	45	3.35
0.5	90	3.37
	75	2.86
	60	4.44
	45	3.88
0.6	90	4.03
	75	3.45
	60	4.97
	45	4.71
0.7	90	4.66
	75	3.96
	60	5.84
	45	5.40
0.8	90	5.43
	75	4.47
	60	5.57



Displacement (mm)	Screw Angle (Degrees)	Load (Newton)
	45	6.02
0.9	90	6.19
	75	4.95
	60	7.32
	45	6.46
1.0	90	6.91
	75	5.45
	60	8.09
	45	7.30
Displacement (mm)	Screw Angle (Degrees)	Load (Newton)
1.1	90	7.57
	75	6.00
	60	8.77
	45	8.00
1.2	90	8.20
	75	6.75
	60	9.08
	45	8.67
1.3	90	8.80
	75	7.14
	60	9.99
	45	9.31
1.4	90	9.37
	75	7.66
	60	10.63
	45	9.93
1.5	90	9.96
	75	8.19
	60	11.26
	45	10.40



Displacement (mm)	Screw Angle (Degrees)	Load (Newton)
1.6	90	10.58
	75	8.72
	60	12.00
	45	10.92
1.7	90	11.14
	75	9.17
	60	12.66
	45	11.54
1.8	90	11.69
	75	9.65
	60	13.01
	45	12.11
1.9	90	12.22
	75	10.15
	60	13.82
	45	12.66
2.0	90	12.63
	75	10.61
	60	14.36
	45	13.21
2.1	90	13.15
	75	11.10
	60	14.85
	45	13.73
2.2	90	13.68
Displacement (mm)	Screw Angle (Degrees)	Load (Newton)
	75	11.51
	60	15.47
	45	14.25
2.3	90	14.21
	75	11.94



Displacement (mm)	Screw Angle (Degrees)	Load (Newton)
	60	16.03
	45	14.75
2.4	90	14.75
	75	12.15
	60	16.30
	45	15.27
2.5	90	15.26
	75	12.65
	60	17.01
	45	15.81
2.6	90	15.76
	75	13.12
	60	17.52
	45	16.27
2.7	90	16.25
	75	13.57
	60	17.97
	45	16.76
2.8	90	16.72
	75	14.06
	60	18.48
	45	17.26
2.9	90	17.16
	75	14.51
	60	18.95
	45	17.72
3.0	90	17.62
	75	14.99
	60	19.14
	45	18.20
3.1	90	18.07
	75	15.45
	60	19.83



Displacement (mm)	Screw Angle (Degrees)	Load (Newton)
	45	18.66
3.2	90	18.46
	75	15.89
	60	20.23
	45	19.11
3.3	90	18.90
	75	16.34
	60	20.60
Displacement (mm)	Screw Angle (Degrees)	Load (Newton)
	45	19.54
3.4	90	19.29
	75	16.79
	60	21.02
	45	19.94
3.5	90	19.66
	75	17.24
	60	21.41
	45	20.34
3.6	90	20.02
	75	17.72
	60	21.51
	45	20.73
3.7	90	20.36
	75	18.16
	60	22.04
	45	21.12
3.8	90	20.63
	75	18.58
	60	22.32
	45	21.48
3.9	90	20.86
	75	18.97



Displacement (mm)	Screw Angle (Degrees)	Load (Newton)
	60	22.64
	45	21.82
4.0	90	21.14
	75	19.39
	60	23.02
	45	22.16
4.1	90	21.23
	75	19.82
	60	23.31
	45	22.50
4.2	90	21.25
	75	20.27
	60	23.33
	45	22.84
4.3	90	21.62
	75	20.71
	60	23.87
	45	23.16
4.4	90	21.92
	75	21.11
	60	24.06
	45	23.49
4.5	90	22.23
Displacement (mm)	Screw Angle (Degrees)	Load (Newton)
	75	21.56
	60	24.34
	45	23.78
4.6	90	22.50
	75	21.95
	60	24.72
	45	24.06
4.7	90	22.73

Displacement (mm)	Screw Angle (Degrees)	Load (Newton)
	75	22.37
	60	23.99
	45	24.31
4.8	90	22.98
	75	22.78
	60	24.05
	45	24.59
4.9	90	23.21
	75	23.19
	60	24.50
	45	24.88
5.0	90	23.43
	75	23.56
	60	24.72
	45	25.16

5.3 Statistical Analysis of Compression Evaluation

5.3.1 Mean Fixation

The average compression load-displacement values (Table 2) were used to derive a graphic illustration of load versus displacement for screws placed at 90°, 75°, 60° and 45° angles. Figure 33 indicates the relative fixation of the various compression screw angle tests (CSAT).

From Figure 33 it is clear that all compression test samples for angled screw applications of 45° and 60° demonstrated more stable results with less displacement for the same compression force delivery than test samples with conventional rectangular screw placement. The screw angle test sample with screws at 75° proved less favourable than all other test samples and can be explained by the minimal screw-tip shifting and travel due to the screw at 75° having bodily rotated through less than its 2mm diameter and having a slight shortening effect of the screw at the angle. It is also noted that with regard to displacement values at force

applications of 0 to 5 Newton and 20 to 25 Newton, no significant stability difference between conventional rectangular screw testing and 75° test samples was demonstrated.

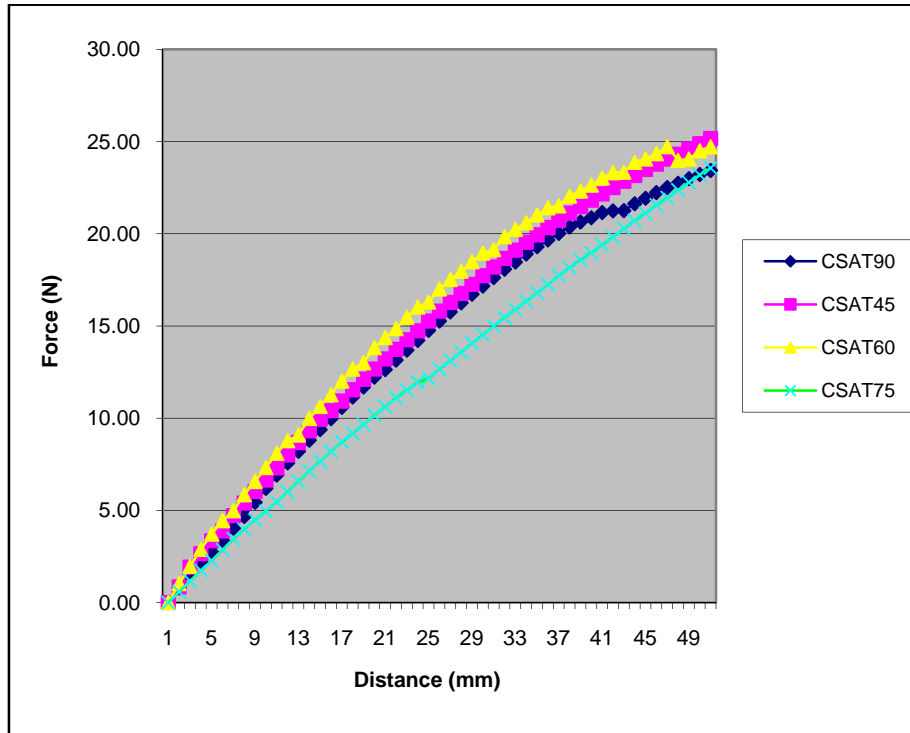

Figure 33: Mean fixation of all the CSAT tests

5.3.2 Statistical Comparison (P-values) of CSAT

Statistical analysis of data of the average CSAT was done. Mean values (x), standard deviation (SD) and the coefficient of variation (CV) for all variables were calculated after data were standardised (zeroed at starting point) and obvious outlying date were deleted after the 95% confidence levels were determined and taken into consideration. Thereafter the statistical variation between the standardised force delivery values of the compression screw angle tests for screws placed at angles of 90°, 75°, 60° and 45° were determined by applying Scheffe's multiple comparison procedure as described in abovementioned Statistix® 8 Analytical Software, Florida, USA.

The statistical comparison (P-values) of all the CSAT screw angle tests is presented in Table 3.



Table 3: P-values of 90°, 75°, 60° and 45° CSAT tests at distances from 0,5 to 5mm extension

CSAT Angle (Degrees)	75°	60°	45°
0.5mm90°	0.067	0.1618	0.4757
1.0mm90°	0.0863	0.0865	0.2335
1.5mm90°	0.0365	0.0614	0.1909
2.0mm90°	0.0268	0.0658	0.1805
2.5mm90°	0.1961	0.0441	0.1029
3.0mm90°	0.358	0.0099	0.0263
3.5mm90°	0.439	0.0091	0.0124
4.0mm90°	0.1683	0.0044	0.0021
4.5mm90°	0.191	0.0232	0.0074
5.0mm90°	0.0359	0.0313	0.0007
0.5mm75°		0.0077	0.0749
1.0mm75°		0.0041	0.0199
1.5mm75°		0.0007	0.0047
2.0mm75°		0.0005	0.0029
2.5mm75°		0.0053	0.0168
3.0mm75°		0.0039	0.0115
3.5mm75°		0.0111	0.0153
4.0mm75°		0.0419	0.0236
4.5mm75°		0.1005	0.0351
5.0mm75°		0.4736	0.0593
0.5mm75°			0.1476
0.5mm60°			0.259
1.0mm60°			0.2468
2.0mm60°			0.2712
2.5mm60°			0.3184
3.0mm60°			0.3353
3.5mm60°			0.4458
4.0mm60°			0.3933
4.5mm60°			0.2897
5.0mm60°			0.0672

From the above P-values it is clear that none of the 75° angled test samples demonstrated significantly higher results than 90°; significantly higher force/displacement values were registered for 60° and 45° angled screw compared to 90°. This phenomenon registered at displacement values of 2.5 through to 5.0mm for 60° angled screws and at 3.0mm for 45° angled screws at an earlier point of displacement at 0.5mm.

5.3.3 Analysis of Load-Displacement Gradients or Slopes

The mean stability slope gradient values as presented in Table 4 were used to derive intercept points for specific load-displacement data.

Table 4: Mean slope gradient values of the force delivery of the SCAT test for screws placed at angles of 90°, 75°, 60° and 45°

	Slope 90	Intercept 90	Slope 45	Intercept 45	Slope 60	Intercept 60	Slope 75	Intercept 75
1	0.4214	7.5257	0.3834	12.022	0.3318	20.61	0.6713	6.8978
2	0.3665	16.15	0.3953	5.6569	0.3663	10.429	0.4794	4.3733
3	0.7418	2.3273	0.4854	11.73	0.4778	13.666	0.2984	8.4693
4	0.3941	15.559	0.4866	2.3069	0.5954	9.6033	0.439	9.3029
5	0.3972	13.822	0.4576	8.6313	0.3686	18.988	0.7265	11.184
6	0.442	8.0916	0.4467	13.391	0.5023	7.043	0.5053	8.2057
7	0.3112	4.43	0.3546	11.75	0.5039	13.339	0.3886	6.8265
8	0.3185	9.8328	0.3472	11.536	0.5551	24.831	0.5014	10.329
9	0.3971	9.2982	0.7798	16.629	0.4046	11.369	0.3388	8.1073
10	0.3887	13.791	0.7493	16.569	0.2916	5.7444	0.3463	8.5761
11	0.698	10.282	0.2674	4.0461	0.4107	8.8772	0.4632	5.5968
12	0.3919	12.792	0.2551	11.152	0.2178	6.8642	0.3041	10.41
13	0.3981	11.057	0.2317	14.963	0.3763	10.344	0.4734	8.0064
14	0.3667	11.995	0.3042	7.7491	0.3400	12.013	0.4377	5.3727
15	0.4224	9.9127	0.3993	15.561	0.2969	7.112	0.335	8.0902
					0.4926	13.537		

Significance was demonstrated for angled screw systems of 60° and 45°. This significance was evident to a displacement value of 4mm. This would appear to have clinical significance for a failure displacement relatively assured to be eminent at 3mm fragment displacement. The force resistance at 0.5mm displacements for all the different angles were compared to determine whether screw angles affect force delivery as shown in Table 2. Average slope values were calculated from data in Table 5.

Table 5: Average slope values for Inclined Screws Insertion (ISI)

	Slope 90	Slope 45	Slope 60	Slope75
1	0.4214	0.3834	0.3318	0.6713
2	0.3665	0.3953	0.3663	0.4794
3		0.4854	0.4778	0.2984
4	0.3941	0.4866	0.5954	0.4390
5	0.3972	0.4576	0.3686	0.7265
6	0.442	0.4467	0.5023	0.5053
7	0.3112	0.3546	0.5039	0.3886
8	0.3185	0.3472	0.5551	0.5014
9	0.3971		0.4046	0.3388
10	0.3887		0.2916	0.3463
11		0.2674	0.4107	0.4632
12	0.3919	0.2551	0.2178	0.3041
13	0.3981	0.2317	0.3763	0.4734
14	0.3667	0.3042	0.3400	0.4377
15	0.4224	0.3993	0.2969	0.3350
			0.4926	
AVG	0.3860	0.3700	0.4080	0.44700

When considering stress force curves of the individual screw angle plates, the slope of the curve give an indication of the relative fixation of the fracture, with higher slope values indicating better fixation. Therefore the slopes of all the stress force graphs for ISI placed at angles of 90°, 75°, 60° and 45° was determined and the statistical variation in slopes were determined by a One-Way ANOVA. The data is illustrated in Figure 34.

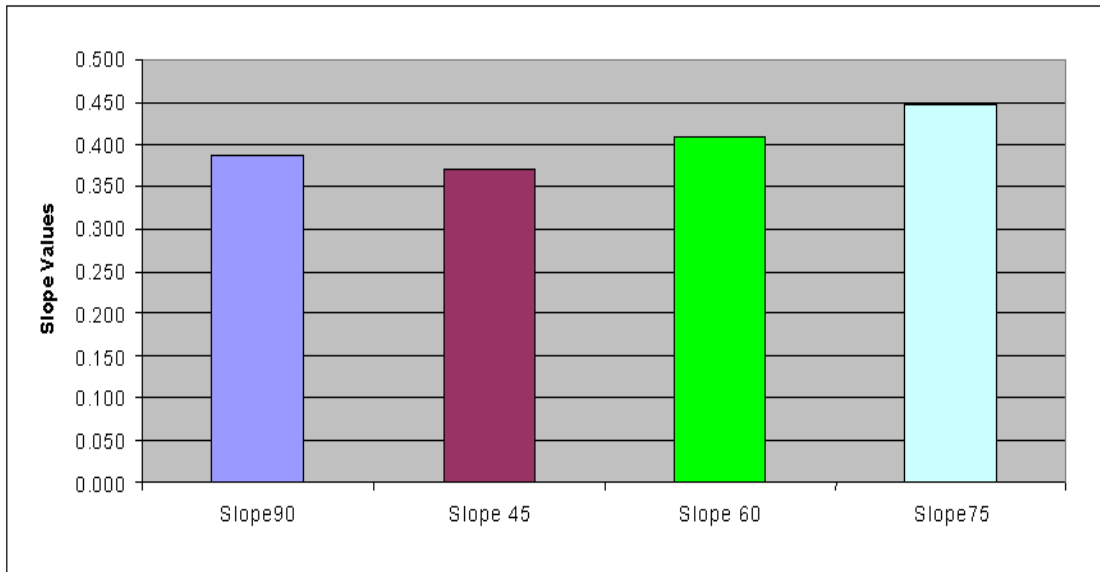

Figure 34: Mean slope values of the force for delivery graphs of the compression screw angle test for screws placed at angles of 90°, 75°, 60° and 45° as determined by the equation for calculating linear trend lines at a distance of 2-5mm extension

Bar graph of mean compression load-displacement slope values for ISI (90°, 75°, 60° and 45° groups) are illustrated in Figure 35. The significantly improved biomechanical stability of a 45° angled screw placement is evident.

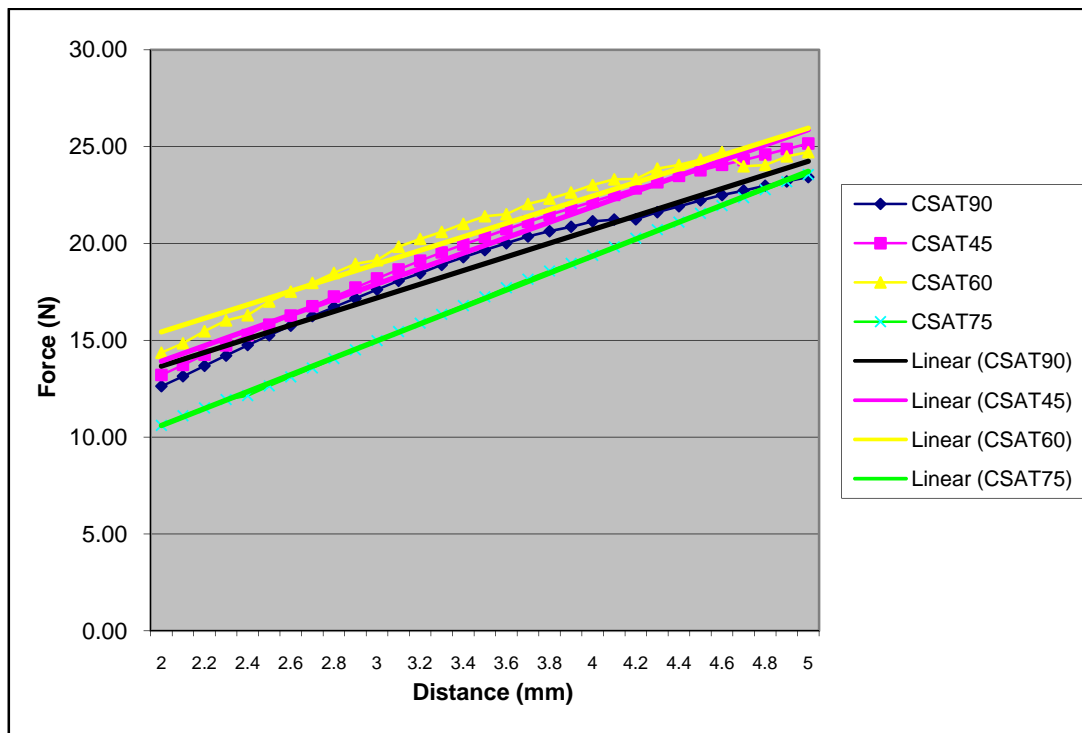

Figure 35: Linear trend lines for mean force delivery values of the tests for screws plant at angles of 90°, 75°, 60° and 45°TSAT.

5.3.4 Linear trend lines

Linear trend lines were calculated using the equation:

$$Y = m.x + b$$

Where **m** is the slope and **b** is the intercept and **x** is the mean load-displacement values.

This information was used to establish linear trend lines of the mean load-displacement values of the various screw angle tests. These results are illustrated in Figure 35. Linear trend lines demonstrated a less stable CSAT 75° angle screw insertion for, when compared to all other ISI angles – a phenomena which could be the result of the relatively small sample size of the groups and could be attributed to insignificant Screw-Tip Travel (STT) and Screw Tip-Shifting (STS).

With the development of multiple angle applications of the Inclined Screw Insertion (ISI) system it is an important consideration to determine the three-dimensional torsion effect on fixated simulations of fractures.

Torsion force displacement test (TSAT) values were registered for displacements at 2mm intervals due to minute measurable displacement values for applied force delivery during experimentation. Torsion was created at a crosshead speed of 1mm/min in an upward motion. The radius of rotation was kept constant by maintaining the same cable angle at the rotating wheel for all test samples.

The standardised data for stress delivery of the TSAT tests for the variables of ISI 90°, 75°, 60° and 45° at displacement values 2, 4 and 6mm, are given in Table 6 to 9.

Table 6: TSAT values of ISI at 90° placement angles

Sample	F-2mm	F-4mm	F--6mm
1	33.727	78.037	119.332
2	24.385	60.065	105.060
3	33.350	81.052	124.922
4	38.227	81.962	126.689
5	33.235	75.112	122.574
6	16.667	54.951	115.763
7	26.275	65.889	109.850
8	9.604	30.497	66.521
9	17.931	44.875	75.871
10	18.191	50.583	100.284
11	17.841	51.003	79.622
12	22.857	65.146	112.192
13	36.453	87.280	120.313
14	35.641	71.637	105.042
15	25.111	55.456	72.426

Table 7: Standardized load (Newton N) TSAT for ISI of 75°

Sample	F-2mm	F-4mm	F-6mm
1	36.140	82.003	125.523
2	30.452	72.169	119.071
3	32.086	66.916	104.004
4	31.207	72.097	113.250
5	36.683	80.059	121.729
6	35.651	77.356	117.020
7	30.936	76.290	121.335
8	37.052	76.729	111.070
9	34.381	71.213	107.143
10	30.618	69.772	113.465
11	31.941	74.008	119.904
12	35.683	70.997	109.669
13	35.827	77.656	119.142
14	34.659	82.219	128.041
15	36.194	80.278	124.948

Table 8: Standardized TSAT for ISI of 60°

Sample	F-2mm	F-4mm	F-6mm
1	35.978	77.522	97.466
2	29.794	66.981	107.72
3	26.942	66.899	109.529
4	33.104	73.71	113.25
5	28.248	65.211	106.61
6	42.737	78.332	126.422
7	19.546	44.621	78.304
8	10.843	30.899	54.364
9	9.941	32.266	64.229
10	34.19	67.792	108.992
11	24.036	49.33	84.478
12	29.343	66.782	108.499
13	34.527	76.625	120.749
14	39.725	81.55	121.704
15	*	*	*

Table 9: Standardized TSAT for ISI of 45°

Sample	F-2mm	F-4mm	F-6mm
1	20.422	51.712	86.368
2	31.6	72.032	108.952
3	36.435	78.134	122.399
4	45.897	92.56	138.696
5	33.81	74.144	114.308
6	29.189	72.529	117.096
7	36.265	80.654	124.818
8	38.128	80.774	116.777
9	43.722	94.001	141.945
10	35.231	78.848	120.87
11	41.064	92.018	140.318
12	29.739	72.006	121.384
13	32.874	72.159	113.723
14	9.707	26.786	50.778
15	19.606	40.189	70.746

The above force displacement data was graphically displayed where load force application in Newton (N) and displacement in tenths of a millimetre was plotted for each angled ISI plate of which Figure 36 is an example.

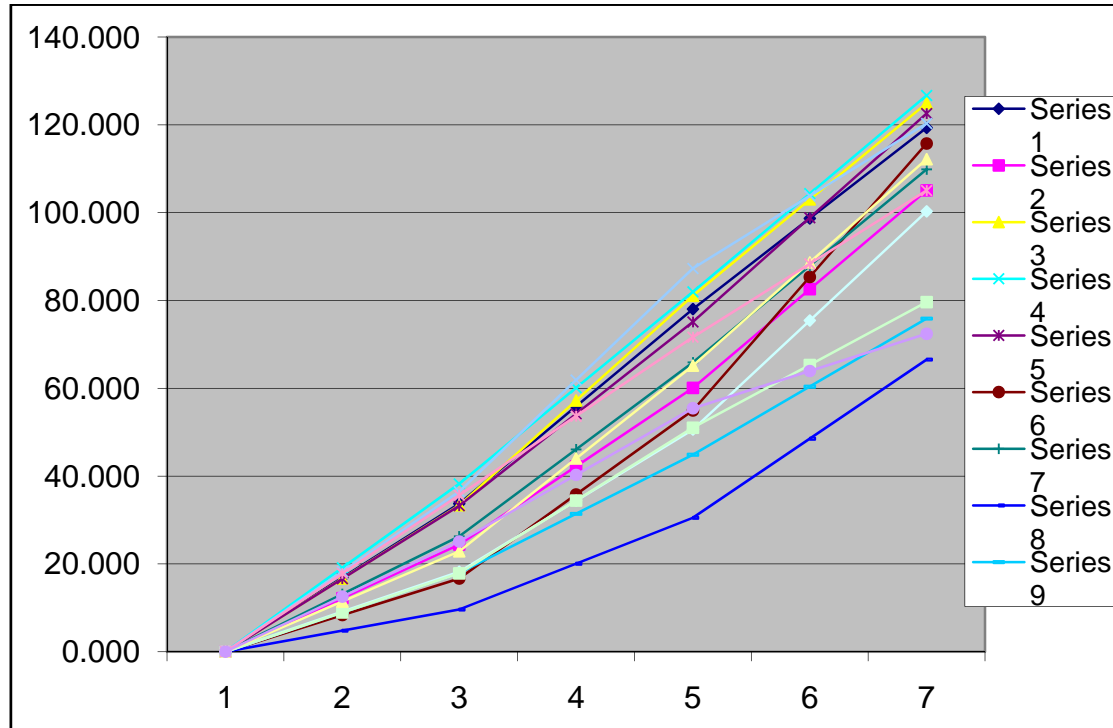

Figure 36: Example of Graphic display of raw data for: TSAT Torsion Screw Angle Test of ISI 60° angle (n-15) test sample

All data gathered during the determination of stress/torsion resistance showed small fluctuations in initial stability. This was ascribed to the settling of the cable. In order to standardize the measurements for each variable the stress resistance zero point was registered at the point where this fluctuation stopped and a constant increase in stress delivery was observed. This meant that measurement of fragment displacement started only after slack in the cable was eliminated and constant increase was observed in torsion force delivery. The load applied to obtain torsional displacement of 2, 4 and 6mm respectively, showed similar incremental increases in all the angles TSAT evaluations.

5.3.5 Statistical Analysis of TSAT

The data obtained in the TSAT evaluations, was used to calculate the mean values (\bar{x}), standard deviations (SD) and coefficient of variation (CV). After standardisation and deletion of outlying data, (only data at 95% confidence level was taken into consideration.) The analysis was done using Statix® 8 Analytical Software.

5.3.6 Mean TSAT Stability

The derived load displacement torsion screw angle test (TSAT) values are expressed in Table 10. Additional mean TSAT forces for displacements of 1, 3 and 5mm were calculated and is reflected in Table 11 below and used to express trend line behaviour for values 1-6mm displacement.

Table 10: The load displacement application for TSAT for displacement values of 2, 4 and 6mm

Inclined Screw Insertion (ISI) Angle (Degrees)	Displacement (mm)	Load (Newton)
90°	2	25.028
	4	64.290
	6	100.370
75°	2	33.967
	4	75.317
	6	117.020
60°	2	34.952
	4	78.044
	6	120.590
45°	2	32.608
	4	67.946
	6	106.980

Table 11: Mean torsion force (stress) values of screw angle tests for screws placed at angles of 90°, 75°, 60° and 45°

ISI angles	Displacement (mm)					
	1	2	3	4	5	6
90°	13.54363	27.08707	44.91378	64.8103	85.80013	109.366
75°	16.98367	33.96733	54.6424	75.31747	96.54057	116.2338
60°	15.34233	29.5708	49.47844	67.89583	87.74387	107.438
45°	16.78654	33.14288	54.58699	76.03111	96.29369	117.8141

The statistical variation between the standardized stress force values for screws placed at 90°, 75°, 60° and 45° (ISI) was determined by applying Scheffe's Multiple Pair-wise Comparison Procedure – thus investigating the patterns among the means that produce these results, the pair-wise comparisons of interest are data was data scanned for significant differences. Table 12 illustrates the clinical relevant displacement from 1-3mm of the fragments fixated with the same length of screw clearly demonstrate higher torsion force (N) values for the same amount of displacement in the inclined screw insertion groups for all of the angles 75°, 60° and 45°, when compared to the conventional 90° screw angle insertion group. For the 60° ISI group (n=15), with same lengths of screws (7mm), no significant difference could be demonstrated ($P \geq 0.05$) when compared to the 90° conventional group; all other angles of screw insertion angles (75° and 45°) demonstrated significance ($P < 0.05$) in torsion force biomechanical stability improvement. The statistical comparison of the derived P-values is given in Table 12.

Table 12: Graphic illustration of P-values of TSAT tests for 1 to 6mm displacement.
The shaded areas express significance

Displacement (mm)/ISI Angle (Degrees)	Inclined Screw Insertion (ISI) Angle P-Values		
	75°	60°	45°
1mm/90°	0.0000	0.0059	0.0000
2mm/90°	0.0000	0.0721	0.0000
3mm/90°	0.0000	0.0001	0.0000
4mm/90°	0.0000	0.0691	0.0000
5mm/90°	0.0000	0.0108	0.0000
6mm/90°	0.0000	0.0600	0.0000
1mm/75°		0.0000	0.4974
2mm/75°		0.0000	0.1509
3mm/75°		0.0000	0.9372
4mm/75°		0.0000	0.4679
5mm/75°		0.0000	0.7978
6mm/75°		0.0000	0.2394
1mm/60°			0.0000
2mm/60°			0.0001
3mm/60°			0.0000
4mm/60°			0.0000
5mm/60°			0.0000



Displacement (mm)/ISI Angle (Degrees)	Inclined Screw Insertion (ISI) Angle P-Values		
6mm/60°			0.0000

The gradient of slope values of ISI angles are listed in Table 13.

Table 13: Gradient of slope values of ISI angled TSAT

Specimen	ISI Angle (Degrees)			
	s l o p e v a l u e s			
	90°	75°	60°	45°
1	17.844	21.208	15.813	19.736
2	17.557	19.99	18.725	18.453
3	17.871	18.165	19.545	20.464
4	18.318	19.099	19.569	19.736
5	18.169	20.488	18.638	19.211
6	19.232	19.696	18.703	19.824
7	18.522	20.573	19.519	21.002
8	17.975	18.701	18.659	20.085
9	18.894	17.937	18.659	19.736
10	16.640	19.006	18.254	20.383
11	18.408	20.134	19.712	19.728
12	19.048	18.189	18.936	20.574
13	19.547	20.008	17.914	19.736
14	17.577	20.002	18.684	19.736
15	17.791	20.999	18.659	19.736
AVG	18.226	19.613	18.665	19.876

The mean slope values are demonstrated in Figure 37.

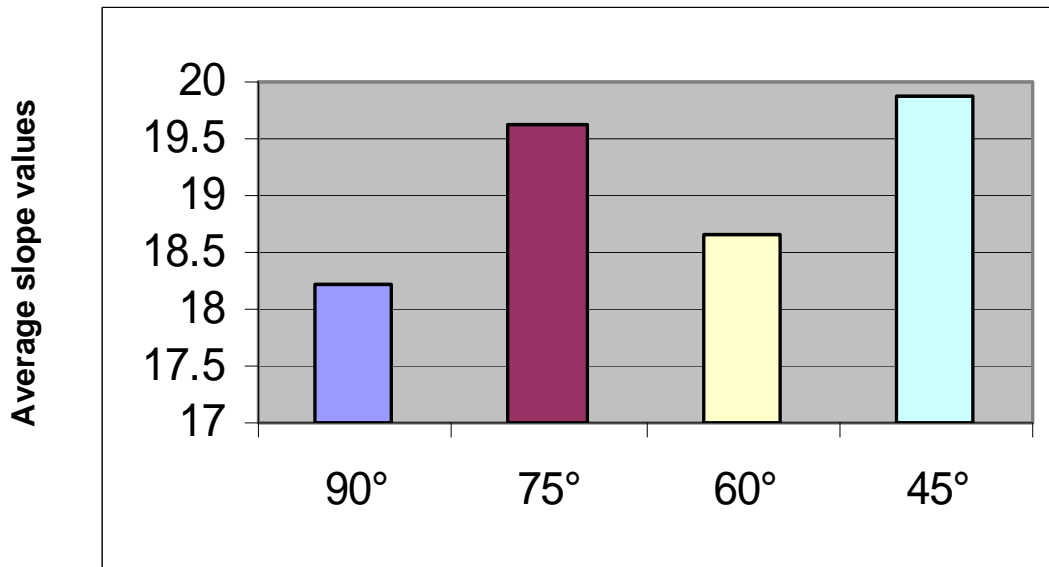

ISI Angulation

Figure 37: Bar graph of mean slope values of TSAT for ISI angles

When average slope values for torsion screw angle testing (TSAT) is considered as in Table 13 and Figure 37, the force displacement stability for the Inclined ISI group of 75°, 60° and 45° clearly demonstrates superiority when compared to the conventional rectangular 90° screw angle group. Significance was proven for (ISI) angles of 75° and 45° with non-significant better results for 60° of (ISI) – this clearly can be expected to be different if the sample size of the *in vitro* study is increased- all indications according to the trend lines (Figure 38) are proof thereof. Mean force (N) values for displacement at 1, 3 and 5mm were calculated to enable trend-line expression (Figure 38).

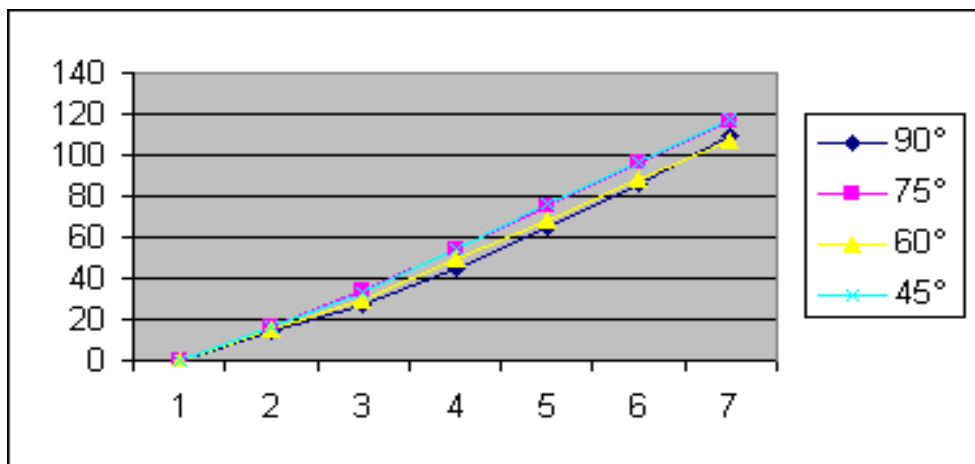

Figure 38: Linear torsion trend-lines

There was no significant difference between ISI of 60° and 75°, however, 45° seem to be showing a very strong trend towards being significantly better when compared to ISI of 75°. When considering P-values of ISI at 45° angle and ISI 60° there seem to be no significant difference in stability between these groups. These values in the specific application in the testing device was seen to be design sensitive – the ISI plates are manufactured with a connecting bar between upper and lower plate holes, which has to correspond to the created fracture line separating the proximal and distal poly-urethane segments for fixation. This connecting bar proved to be too short with the result that the angulated plate hole Nr. 3, therefore closest to the fracture line, when inclined at 45°, results in cortical bone destruction when pilot drilling – the slight lag effect seem to have compensated for the resultant biomechanical instability. Increasing the connecting bar length would result in an increase in the plate-hole distance to the fracture-gap and permit angle drilling without the destruction seen for both CSAT and TSAT, ISI - 45° and 60°, angle testing.

The statistical comparison (P-values) of the mean slope values are compared in Table 14.

Table 14: P-values of the mean slope values for TSAT evaluation

TSAT Angle	ISI Angle Degrees		
Degrees	75°	60°	45°
90°	0.0000	0.0003	0.0019
75°		0.1564	0.0556
60°			0.2740

5.4.1 TSAT Linear Trend Lines

Results of the mean slope value comparison (in Table 15) demonstrates significant better (TSAT) results for ISI 75°, 60° and 45° when compared to conventional 90° screw angle insertion. The regression trend lines derived from the slope value for a given displacement are listed in Table 15. The formula: $y = m.x + b$ is applied.

Table 15: Mean slope values of the torsion force (TSAT) of the screw angle tests for screws placed at angles of 90°, 75°, 60° and 45°

Specimen	90°	75°	60°	45°
1	40.231	42.243	33.394	*
2	35.086	39.893	36.035	36.729*
3	42.247	34.684	36.854	40.890
4	42.380	38.064	38.036	46.275
5	40.960	40.856	35.679	38.326
6	38.557	39.277	41.486	39.463
7	36.916	40.936	25.999	41.884
8	22.043	37.289	18.315	39.298
9	25.456	35.826	21.501	47.611
10	33.324	37.955	36.058	40.623
11	27.203	40.178	27.873	47.191
12	37.887	36.432	36.294	40.942
13	41.177	39.926	40.435	38.045
14	35.112	43.168	40.694	16.941
15	24.762	41.893	*	23.282

* Data excluded due to experimental set-up failure noticed after completion of the *in vitro* biomechanical testing."

CHAPTER 6 INTERPRETATION OF RESULTS

6.1 Trigonometric - Mathematical Formulation of Angled Screw Application Results

Optimum mono-cortical screw length is equal to the cortex thickness available and determined by the specific anatomical site of the mandible. If screws are placed (applied) perpendicular to the bone surface, as is the case in conventional practice, and screw length which exceeds the optimal cortical thickness is placed mono-cortically it will have a screw thread portion in medullary bone. This section of the screw is in less dense bone than homogenous compact cortical bone. The polyurethane mandibles effectively simulate normal human anatomy by having a dense outer cortical layer and less dense medullary component. A screw of 7mm length, placed anatomically at the external oblique ridge would have a section of screw transecting the cortex. Optimally the cortical thickness can vary and be equal to $3.5\text{mm} + 0.6 = 4.1\text{mm}$ in the mandibular angle region distal to the third molars (Figure 11 B) therefore cortical component of the screw would represent 4.1mm of the 7mm, resulting in $7\text{mm} - 4.1\text{mm} = 2.9\text{mm}$ screw length in medullary bone, if placed perpendicular to the bone surface.

If for the same anatomical position on the mandible, as standardised in the protocol, the angle of screw insertion is changed to an angle less than 90° , the medullary screw portion will rotate out of cancellous, less stable bone into amorphous cortical bone with a resultant biomechanical stability improvement. This amount of screw tip travel (STT) can be calculated and predicted mathematically thus explaining the improved load/displacement outcome for screw angle variation between 90° and 45° angles (Figure 39).

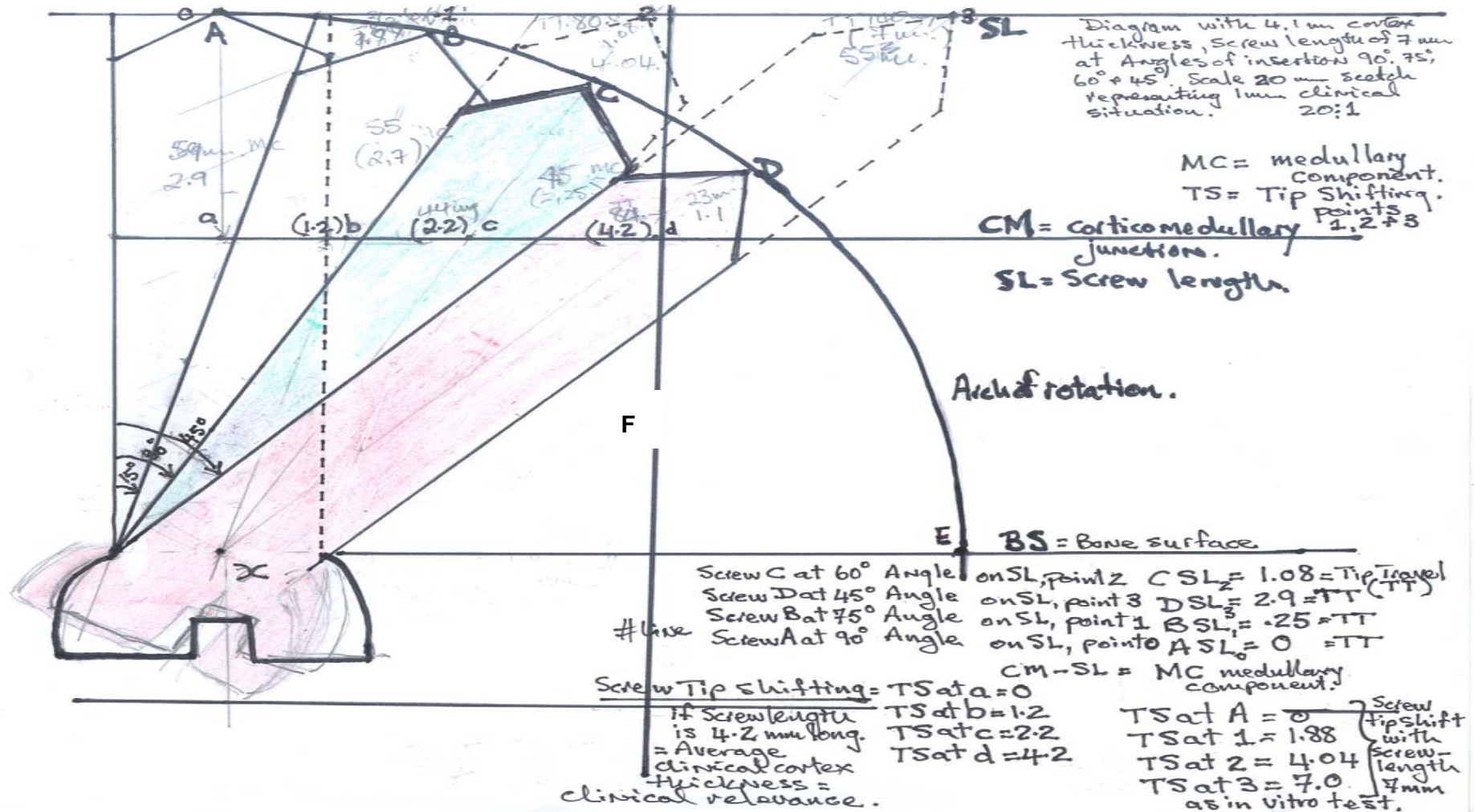

Figure 39: Screw tip travel and shifting of Inclined Screw Insertion in a mono-cortical application with screw length 7mm and screw diameter 2mm

The screw rotation from 90° rectangular to 45° optimizes screw tip travel through dense cortex allowing the full 7mm screw length to transect cortex with minimal or no medullary engagement explaining higher values in biomechanical stability for screw angles 45° and 60°.

The initial rotation through 15° for a screw angle of 75° has no significance for a screw length of 7mm and 2mm diameter in terms of stability compared to 90°. The screw apex or tip, screw tip shifting (STS) has moved minimal through point A-B and the screw portion in medullary bone, differs very little from the 2mm diameter medullary screw engagement seen at 90° angle position.

Screw tip travel between point A and C along an arc shortens the screw length in medullary bone as it rotates around the screw head (midpoint x) from 90° to 60°. A lesser shorter screw length engages medullary bone with more significant screw length transecting better quality more dense cortical bone optimizing cortical screw length in cortex as it further rotates to point D (Figure 39) where theoretically all of the 7mm mono-cortical screw transects cortex with no medullary component involved ($z-y = 0\text{mm}$).

The mathematical calculation of screw tip travel (STT) between points A, B, C and D from point-A in increments of 15° from 90°; to 75°; 60° and 45° angles can be determined by trigonometry when triangles AX1; AX2 and AX3 are used for calculations. The known constant in all cases would be the length of XA which is the standardised 7mm screw length used in the investigation also known are the angles of screw insertion AxB; AxC and AxD with values 15°; 30° and 45° to AX, measured 15 from point x in a clockwise direction. Point X is a common rotation axis positioned midpoint at the screw neck.

If this amount of screw shortening for medullary engagement or lengthening for cortical engagement is to be calculated the following linear lengths should be measured and DZ as they increase in length and lines $A_0 B_1$, C_2 and XB_1 ; XC_2 and XD_3 where XA_0 equals 7mm and D_3 as they decrease until point D is reached on the arch of rotation as the optimal cortical travel angle for the 7mm screw length where minimal medullary engagement is seen and cortical bone engagement is optimal. It was determined by means of CAD – three-dimensional simulation that a screw of 2mm diameter placed at AXE angle of 30° to the plate surface would have thread partially outside bone on the inner surface of the plate, lifting it from the bone without engaging cortex (Figure 40).

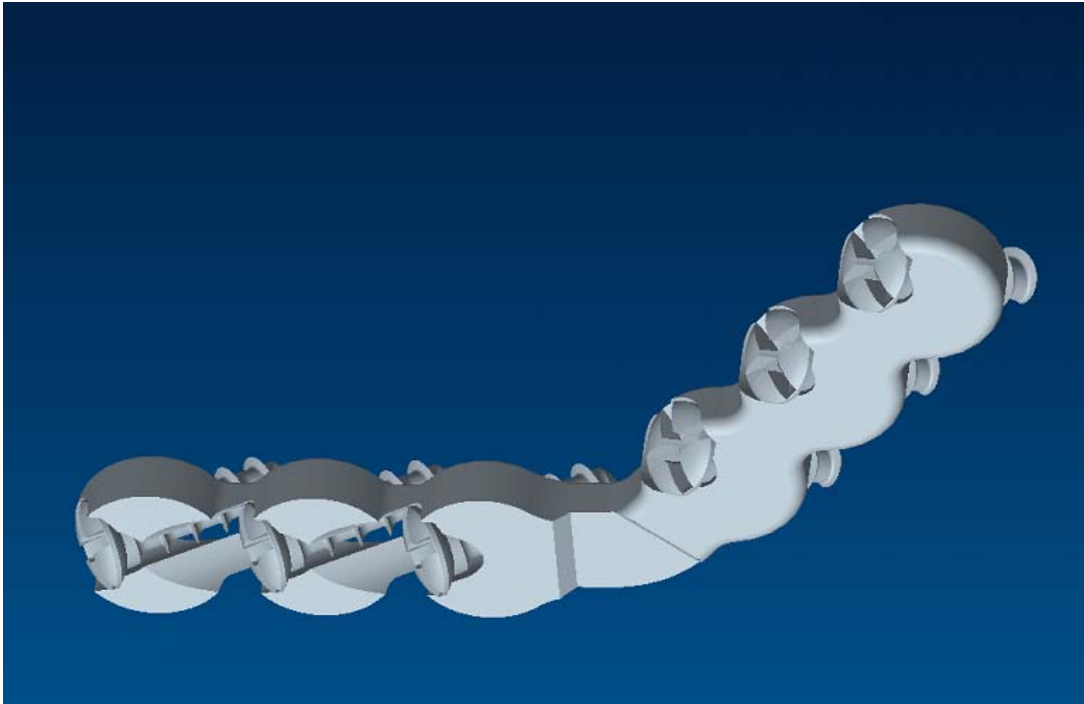

Figure 40: Three CAD simulation of screw angle placement of 30°

6.2 Defining and Measuring of STS (Screw Tip Shifting)

Screw tip shifting (Figure 40) refers to the distance travelled by the screw apex along a line of optimal screw length (SL) or the cortico-medullary junction line (CM) for different angles of screw placement where 0 is 15°, 30° or 45° reflected as angles AXB₁; AXC₂ or AXD₃. The linear measurement (Figure39) :

SL₁ = screw tip shifting along optimal screw length, line SL at - 15° (AXB₁) angle measured from A (screw at rectangle 90° and 7mm length) along SL.

SL₂ = Screw tip shifting distance along optimal screw length line SL, at 30° AXC₂ angle measured from point A.

SL₃ = screw tip shifting distance, along optimal screw length line, SL, at 45° AXD₃ angle, measured from A.

6.3 Clinical/Experimental Significance of STS (Screw Tip Shifting)

The screw tip shifting (Figure 40) is a reflection of lag potential of a screw for a particular angle of application measured in relation to conventional rectangular screw placement. It reflects the ability of a screw to transect an oblique fracture line relative to the anterior cortex surface.

1. Screw tip shifting can be measured for the optimum screw length, if inserted at angles 75° , 60° and 45° at 15° intervals to rectangular, along optimal screw length line SL to reflect length difference to 7mm screw length at 90° .
2. Screw tip shifting can be measured at the cortico-medullary (CM) junction for insertion angles 75° , 60° or 45° along line CM (at points a b c d) to reflect lag potential within a given amount of cortex available (The cortex is 4.1mm. thick at the angle of mandible).

For rectangular screw placement the entry point of a screw at the outer cortex bone surface corresponds and is in line (Xa) with the inner cortex CM-junction and is utilised referred to as the conventional gold standard in clinical application.

6.4 Defining and Measuring of Screw Tip Travel (STT)

Optimal screw length for a given angle of application is measured relative to a 7mm screw length for rectangular screw placement and is defined as screw tip travel. This value is a reflection of the change in screw length related to the screw insertion angles of 15° , 30° and 45° for a screw of 7mm length. Screw travel through bone should increase progressively for angles 75° , 50° and 45° - longer screws can be used for more acute screw angle placements and has clinical relevance until the angle 30° (AXE) is reached on the arch of rotation when the screw thread of a 2mm diameter screw travels to close to the bone plate interface rendering it unstable.

It should be possible to calculate an optimum screw tip travel (STT) increase for:

- a) Optimal screw length on line SL where screw length at point A_0 for rectangular screw angle was 7mm and points XSL_1 , XSL_2 and XSL_3 for angles 15° - 45° from 90° .
- b) Optimal screw length on line CM where DCa equals 4.1mm cortex available at

rectangular screw placement and Xb at 15° from, 90° (75°); Xc at 30° from 90° (60°) and Xd at 45° from 90° (45°).

I. Screw tip shifting (STS) determination

(1) Optimal screw length screw tip shifting for screw angle 15° from 90° (angle 75° application)

a) The screw tip shifting for 15° angled, optimal screw along line SL is determined TAN – where $SXSL_1 = 15^\circ$

$$\therefore \tan 15^\circ = ASL_1 / AX$$

$$\therefore \tan 15^\circ \times Ax = ASL_1$$

$$\therefore ASL_1 = \tan 15^\circ \times 7\text{mm}$$

$$ASL_1 = 1.88\text{mm}$$

where A0 is the screw tip position for 90° rectangular screw placement. A screw tip 1.88mm from A₀ reflects a significant increased lag potential of 1.88mm.

b) Screw tip shifting for 15° angles screw on line CM at point b optimal cortex available:

$$\tan 15^\circ = ab/ax$$

$$\tan 15^\circ \times ax = ab$$

$$\tan 15^\circ \times 4.1 = ab$$

$$ab = 1.10\text{mm}$$

(2) Optimal Screw Tip Shifting for Screw Angle Application 30° from 90° (60°)

a) Measured on SL at point SL₂: - Optimal screw length

$$\tan 30^\circ = ASL_2 / Ax$$

$$\tan Ax \times 30^\circ \times 7\text{mm} = ASL_2 = 4.04\text{mm}$$

(b) Measured on CM at point C : - optimal cortex engagement

$$\tan 30^\circ = ab/ax$$

$$\tan 30^\circ \times 4.1\text{mm} = ab$$

$$ab = 2.37\text{mm}$$

(3) Optimal screw tip shifting for screw angle application 45° from rectangular (90°) equal to a 45° screw angle application

(a) Measured on SL at point ASL_3 determined by

$$\tan 45^\circ = ASL_3/AX$$

$$\tan 45^\circ \times AX = ASL_3$$

$$\tan 45^\circ \times 7.0\text{mm} = ASL_3$$

$$ASL_3 = 7.0\text{mm}$$

(b) Measure on CM at point d = optimal cortex engagement

$$\tan 45^\circ = ad/Xa$$

$$\tan 45^\circ \times Xa = ad$$

$$\therefore ad = \tan 45^\circ \times 4.1$$

$$ad = 4.1\text{mm}$$

Screw tip shifting is determined using tan of the angle of screw application (15° , 30° and 45°) multiplied by optimal screw length 7mm. For optimal screw length shifts along line SL or optimal cortex engagement along line CM which calculated the tip shifting in linear measurement from point A or a which is the exit point for rectangular screw AX or Xa.

A screw can shift along an imaginary line SL (Figure 39) to compare the tip shift at placement angles of 75° , 60° and 45° with a screw tip position when placed rectangular at length 7mm. The screw shift will represent a different exit point for a screw tip at the inner surface of the bone cortex in relation to the entry point on the outer cortical surface. The tip shift is a reflection of screw ability to align itself more rectangular to the fracture line as opposed to screw angle rectangular to the bone or plate surface. Tip shift will predict lagging ability of screw across an oblique fracture line.

Table 16: Screw tip-shifting results

Application Angle	At Line SL	At Line CM
90°	0mm	0mm
75°	1.88mm	1.10mm
60°	4.04mm	2.37mm
45°	7.0mm	4.1mm

II. 1. Screw Tip Travel Determination at 15° angle Application from Rectangular (75°)

- a) Screw tip travel (STT) represents an increase in screw length at angle 15° less than 90° measured on SL - reflecting optimal screw length application at 75° compared to 7mm screw length if placed at 90° angle.

$$\text{Angle} = \text{AXSL}_1$$

$$\text{Cos } 15^\circ (\text{AXSL}_1) = \text{XA} / \text{XSL}_1$$

$$\therefore \text{XSL}_1 = \text{XA} / \text{Cos } 15^\circ = 7.25\text{mm}$$

$$\text{XSL}_1 - \text{XB} = 0, 25 \text{ when}$$

(XA rectangular is 7.0mm)

- b) Screw tip travel screw length for angle 15° measured at CM – screw length arrangement for optimal cortex available 4.1mm

$$\text{Cos } 15^\circ = \text{Xa} / \text{Xb}$$

$$\text{Cos } 15^\circ / \text{Xa} = 1 / \text{xb}$$

$$\therefore \text{xb} = 4.24\text{mm}$$

2. Screw Tip Travel Determination at 30° from 90° Angle Application (60°)

- a) Measured at SL reflecting optimal screw length for angle 30°.

Determined by Cos AXSL₂

$$\text{Cos } 30^\circ = \text{XA (7mm)} / \text{XSL}_2$$

$$\text{Cos } 30^\circ / \text{XA} = 1 / \text{XSL}_2$$

$$\therefore \text{XSL}_2 = 7\text{mm} / \text{Cos } 30^\circ$$

$$\therefore \text{XSL}_2 = 9.08\text{mm}$$

- b) Measured at CM reflecting optimal available cortex available 4.1 at angle 30°

$$\cos 30^\circ = X_a / X_c$$

$$X_c = X_a / \cos 30^\circ$$

$$X_c = 4.1 / \cos 30^\circ$$

$$\therefore X_c = 4.73\text{mm}$$

- 3) Screw tip travel determined at 45° from rectangular measured at

- a) SL_1 reflecting optimal screw length for Angle 0 = $AXSL_3$

$$\cos 45^\circ = AX (7\text{mm}) / XSL_3$$

$$\cos 45^\circ / 7\text{mm} = 1 / XSL_3$$

$$\therefore XSL_3 = 7\text{mm} / \cos 45^\circ$$

$$\therefore XSL_3 = 9.89\text{mm}$$

- b) Measured at CM reflecting optimal screw length for available cortex thickness 4.1mm to be engaged. Angle - = $aXd = 45^\circ$

$$\cos 45^\circ = X_a / X_d$$

$$\cos 45^\circ / 4.1 = 1 / X_d$$

$$\therefore X_d = 4.1 / \cos 45^\circ$$

$$\therefore X_d = 5.79\text{mm}$$

Screw tip travel is determined by cos of the angle of screw application (15°, 30° and 45°) and dividing it into the given cortex thickness of 4.1mm for the anatomical site of the angle of the mandible to calculate the maximum screw length to be used at a given angle and known cortical thickness of 4.1mm.

By calculating the difference between standard screw length of 7mm and the new screw travel distance possible for a given cortical bone thickness an increase in screw length application is to be expected as the angle of screw insertion changes from 90° to 75°, 60° and 45° with increments of 15° from conventional rectangular screw position as indicated in Table 17.

Table 17: Screw tip travel results (lengthening)

Angle of Application to	Bone/Plate Surface	Measured at SL	Measured at CM	Screw Length Increase At SL	Screw Length Increases at CM
90°	Point A ₀	0mm	0mm	0mm	0mm
75° (15°)	Point SL ₁	7.25mm	4.24mm	+ .25mm	+ 0.14mm
60° (30°)	Point SL ₂	8.08mm	4.73mm	+1.08mm	+ 0.63mm
45° (45°)	Point SL ₃	9.89mm	5.79mm	+2.89mm	+ 1.69mm

Calculation and determination is made for a given cortical thickness of 4.1mm along line CM (cortico-medullary junction line) or for a given optimal screw length along line SL measured from point X – a mid-rotation point located at the screw head.

6.5 Clinical Relevance of Trigonometric Calculations

From the screw tip travel and screw tip shifting results it is concluded that longer screws can optimally be used when applying mono-cortical screws at angles smaller than 90° and that tip travel will also contribute to lagging across the fracture line of a mandibular angle fracture (Figure 39).

Its relevance is angle related and will vary according to the substrate thickness transected by a screw of optimal length. In the biomechanical stability study conducted using screws of same length, the screw will rotate for different angles and provided the screw length utilized equals the cortex thickness at all times it will produce superior significant biomechanical stability results if compared to a screw placed rectangular. No significant stability difference is expected and was demonstrated with an angle change of 15° - screw sip shift only 1,09mm and tip travel-lengthening 0,14mm if screw angle placement is 75°.

For angle placement of 60° in 4.1mm cortex the screw tip shift was 2,37 and the tip travel (lengthening) was 0,63 with expected significant stability improvement.

For angle placement of 45° in 4.1mm cortex tip shifting was 4.1mm cortex and screw tip travel (lengthening) was 1,69mm where lagging across a fracture line (represented by vertical line F in Figure 39), becomes evident.

It should be noted that a screw tip shift of 1.09mm indicates a bodily shift of the screw of approximately fifty percent of its 2mm diameter and no biomechanical stability improvement is to be expected.

For horizontally and vertically unfavourable mandibular angle fractures⁴⁰ mono-cortical screws at angles 60° and 45° can be expected to improve fracture fragment stability by resisting forces in both horizontal (Figure 31) and vertical dimensions (Figure 32) when compared to rectangular screw placement for screws of same length due to fracture-line orientation.

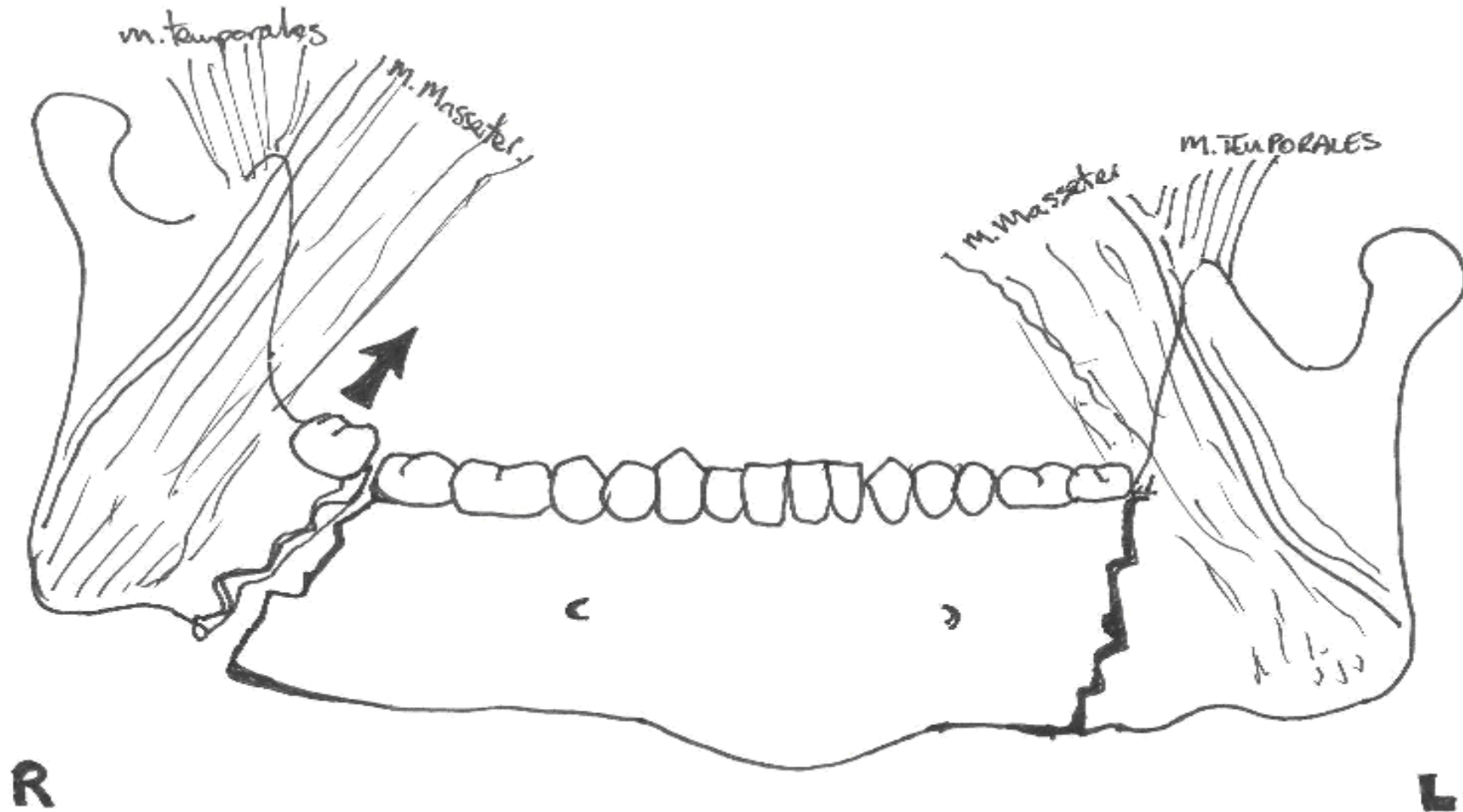
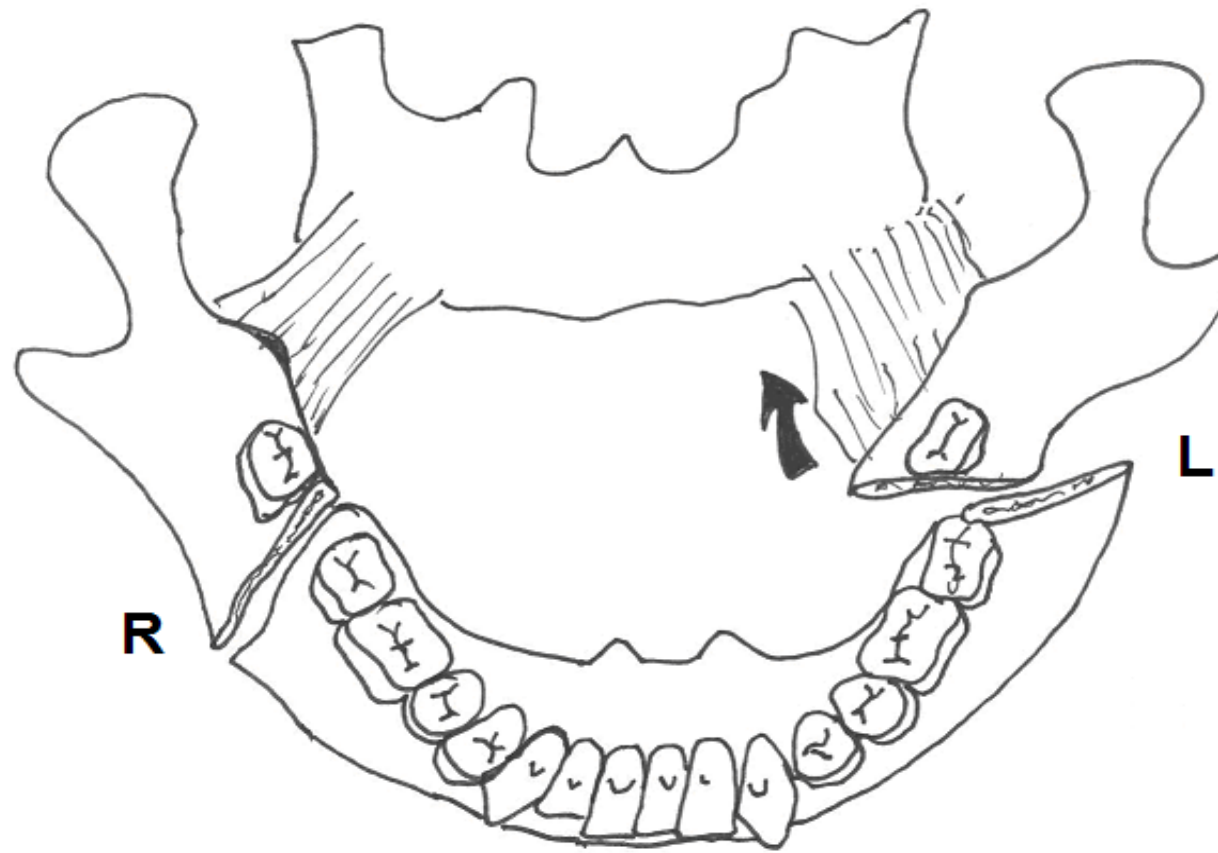

Figure 31: Horizontally unfavorable fracture right angle of the mandible



R = Vertical favourable fracture angle of mandibular

L = Vertical unfavourable fracture angle of mandibular

Figure 42: Medial pterygoid muscle action on the proximal fragment of a mandibular angle fracture

CHAPTER 7 DISCUSSION AND RECOMMENDATIONS

7.1 Discussion

7.1.1 Materials and Methodology

(a) The range of force application

The clinical relevance and therefore the credibility of any *in vitro* biomechanical stability study is dependent on the ability of the testing device to simulate human mandibular behaviour during function.^{7, 14}

The bending and torsion moments exerted on the fixated fracture/osteotomy-mandibular replicas) had clinical relevance to the post-operative force range applicable during the healing period for osteotomy and fracture treated patients. The load force application for the ISI biomechanical study was in the range of 100-200N (0-10 Kg.). A 0-100 Newton force range simulated the maximum incisal-edge, and the 0-200 N range simulated maximum contra-lateral molar loading in the post-operative clinical situation.^{8, 9, 11, 12}

(b) The testing device

An unique biomechanical testing device (Figure 15), which was specially developed proved to be reliable and economical as a three dimensional force applicator which rendered clinical relevant results. Torsion (TSAT) and compression (CSAT) forces within clinical relevant range was utilised to deliver a torsion force to the distal fragment of the osteotomised polyurethane hemi-mandibula whilst the proximal segment was rigidly fixated. The compression force (CSAT) was applied to the occlusal surface of the first molar of the mandibular replicas mounted in the testing device. This resulted in a positive bending motion with tension created superior in the fixated fragments and compression at the lower border of the polyurethane human mandibular replicas.^{1, 2, 6}

Instead of simulating torsional moments by load application to the incisal or contra-lateral molar teeth of complete mandibular replicas,^{5, 22} this study is unique in that torsion force application to the distal segment of a fixated hemi-mandibula via a clamp jig and rotating wheel is applied.

The cable was linked to the load cell of the Zwick machine with an upward constant cross-hair speed. This design for a biomechanical testing jig is unique³² although the rotation force delivery and calculation is similar to the experimentation performed by Feller and co-workers in 2002, where acrylic blocks were used to investigate fixation stability.^{33, 34} This method of torsion force delivery has a cost saving effect as the tests were conducted in hemi-mandibular segments as opposed to complete poly-urethane mandibular replicas.

(c) The ISI experimental osteosynthesis plate

This unique C-shaped six-hole plate was of own design and manufactured by Stryker Leibinger (Figure 29). It served as a proto-type for the eventually patented ISI mandibular angle plate, used in patients. The angled screw plates described by Krenkel³⁵ demonstrate a quadrant orientation for straight plates either in the long axis of the plate (quadrant 3) for all the plate holes, or angled at 45° and described as the screws are inserted from one side at an angle of 45° from the right of the long axis of the plate for type B/1, and for B/2 where the screws are inserted from one side at an angle of 45° from the left of the long axis of the plate. The type A - 0° slanted screw plate where the screws are inserted from one side along the long axis of the plate again have all plate holes in the same (quadrant 3) orientation (Figure 1). The 0° slanted plate described by Krenkel had washers to improve stability at the screw head plate hole interface, it was suggested that the plate holes would accommodate a screw angle of insertion between 0-180°. The ISI plate in contrast has an angled plate hole to accommodate a specific screw angle of insertion guided by the pilot hole drilled with the aid of a specific drill-guide.

The plate-holes are either rectangular to the plate surface (conventional 90° angle) or angled at 75°, 60°, and 45° to the plate surface, with a specific quadrant orientation described in this research for the first time to facilitate communication in terms of angled screw insertion (Figure 1). In the ISI plate the proximal plate holes were angled in quadrant one with lag potential for the screw bordering the fracture line and for the anterior three holes the angle of insertion was orientated in quadrant three to facilitate direct line of sight during intra-oral approach. The ISI design therefore is unique and differs from any angled screw insertion plate suggested by Krenkel.³⁶ Due to an absence of biomechanical stability studies in the literature specifically investigating the effect of angled screw placement at different quadrant orientations within the same plate, the results of this study cannot be compared to, or interpreted

in relation to other studies. The screw angle orientation favours a more rectangular alignment to the fracture site (Figure 5) in both horizontally and vertically unfavourable fractures.

It should be noted that if the plate holes were designed according to the "lock-plate" principle, it would allow freedom of 10° angle variation for the screw placement within a dedicated plate hole. The angled plate holes can serve as a drill guide if the pilot drill is aligned along the slant of the plate hole profile.

The biomechanical behaviour comparison for different angles of screw insertion, within the same plate profile, is a first ever performed *in vitro* study. The screws with ISI angles of 75°, 60° and 45° were biomechanically compared the conventional gold standard of screw placement at a 90° angle.

(d) The simulated mandibular fracture/osteotomy

The angle sectioning of the mandibular replicas was performed in an oblique fashion starting the cut from anterior in alveolar region of the mandibular angle to terminate in a point more posteriorly at the inferior border of the Gonion simulating horizontally unfavourable fragments. The same bone cut begun in an anterior position on the lingual aspect to terminate more posterior on the buccal aspect (lateral) thus rendering the fragments vertically unfavourable. The same cut was simulated on all models using a jig. In a recent finite element analysis for tension band fixation of mandibular angle fractures it was demonstrated that in fractures with an angle of more than 20° with the mesial surface of the proximal molar (indicative of the degree of horizontally unfavourability of the fracture fragments due to muscle pull) and no inter-fragmentary contact (load bearing), fracture mobility for both incisors and ipsi-lateral fracture molar forces was lower than 150N but fracture mobility above 150N for contra-lateral molar bite forces was registered.³⁶ Mono-planar mono-plating with ISI plates could prove stable enough and render better results.³⁷

The *in vitro* biomechanical stability study performed by Nissenbaum and co-workers on Chacma baboons³⁸ (*Papio ursinus*), investigating horizontally and vertically unfavourable fracture stability, creates confusion as the authors interpreted the fragment displacement directions according to the direction of muscle pull-vertical for masseter and temporales muscles and horizontal for the medial pterygoid muscle pull. Many biomechanical stability studies do not pay attention to the direction of

instability created by sectioned models and therefore do not relate to the clinical situation.

7.1.2 The anatomical site chosen for the ISI plate

Plate positioning would affect the biomechanical stability of a specific plate fixation. This knowledge is based on the strain lines that develop during mandibular function, which delineates the ideal osteosynthesis lines previously described.^{4, 14} The ISI plate was geometrically shaped to cover the tension strain line, just below the external oblique ridge, on the lateral aspect of the mandibular angle (Figures 12 & 43).

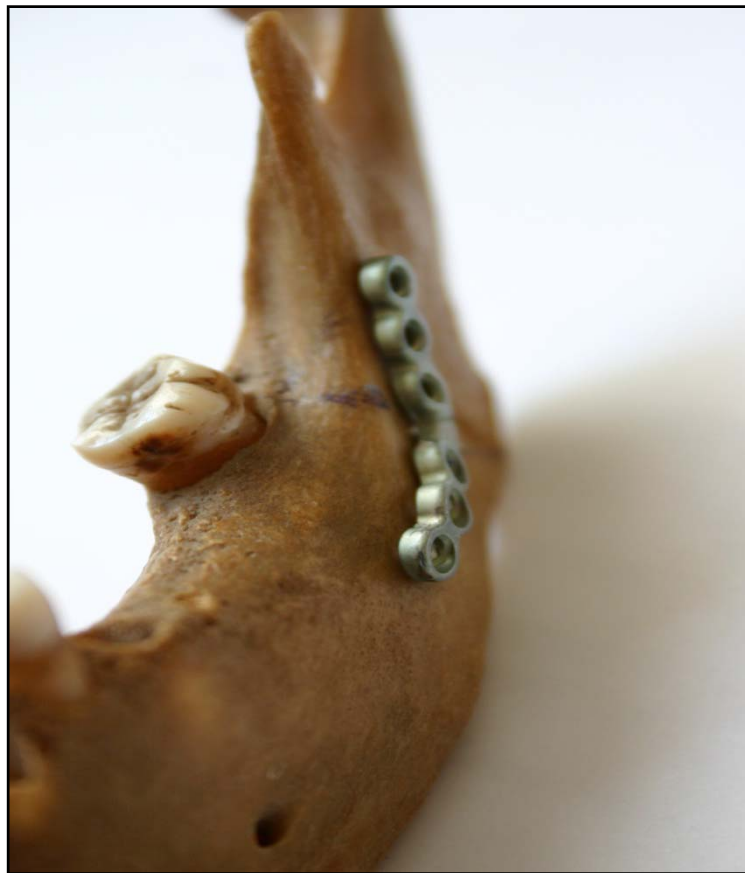

Figure 43: Position of ISI plate at the angle of mandible

Plate positioning clearly influenced biomechanical stability as described in previous studies, a superior border mono-cortical plate (Wurzberg plate) placed superior on the external oblique ridge¹⁵ demonstrated inferior gapping¹⁴ and demanded tension banding by placement of a second plate³⁹ on the infero-lateral aspect of the mandibular angle. This suggested a bi-plating technique in a bi-planar fashion if mono-cortical plates are used,^{18, 22} which in turn demands a trans-cutaneous^{30, 32} surgical approach as opposed to a intra-oral, less invasive procedure.^{3, 4, 6} This osteosynthesis position guarantees utilization of the ideal maximum dense cortical

thickness available for mono-cortical screw fixation.^{27, 28} The screw length can be stepped up (increased) to 9mm for the transecting (lagging) screw resulting in a tremendous improvement in the biomechanical stability (Figure 44). The screw remains in dense cortical bone for all of its length.

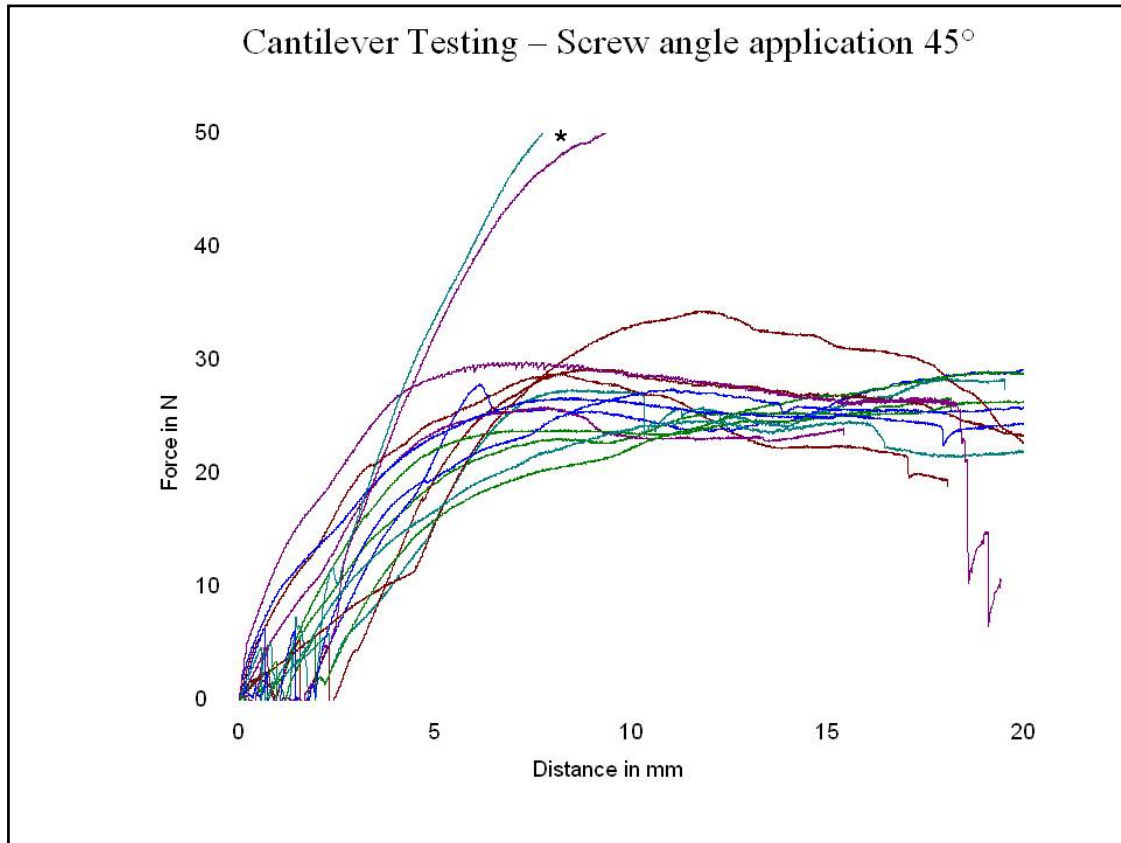

Figure 44: Effect of Screw lagging across the fracture line-stability improvement using longer (9mm) screws*

7.1.3 Independent biomechanical stability testing results of the ISI osteosynthesis system.

The independent biomechanical *in vitro* tests performed by Schieferstein using the mandibulator (Addendum 4) gave clinical significance to the ISI plate previously referred to as the MIMAS (Minimal Invasive Mono-Cortical Angle System).²⁹ The aim of his study was to evaluate the ISI plate as a possible new concept and compare it's stability with the plates commonly used and available in the market the Wurzburg superior border plate¹⁵ and the bi-cortical universal fracture plate. Schieferstein measured and compared the displacement after delivery of stepwise 50N force application increments to a maximum of 250N. The force delivery mimicked muscle forces and dental forces during incisal, molar, contra-lateral or ipsi-lateral force

application. Load dependant angle changes between Kirchner wires (inserted in the poly-urethane mandibles) were registered for bending (CSAT in this study) and torsion moments (TSAT). An instability factor was calculated with the formula $I = (B^2 + T^2) \times 0.5$. These results proved the instability of the Wurzburg plate when ipsilateral loading is performed. The average stability of the universal plate proved to be 37% higher but 13% less balanced than the ISI plate (Addendum 4). These independent results proved that the ISI plate was very stable and confirmed results obtained and reported^{26, 34, 39} of this in vitro study. The ISI plate has proven to have superior biomechanical stability to the Wurzburg plate. Similar to the Wurzburg plate, it has the advantage of application for an intra-oral surgical technique.

Improved fragment stability is proven for forces of tension/compression and torsion for the same screw length and diameter screws placed mono-cortically as a plating system provided the screw length (7mm – in this study) chosen initially exceeds the cortical thickness of a specific anatomical topographical site (1,7mm – longer than the cortex thickness of 4mm in the angle of the mandible). In clinical terms, longer screws for angles 60° and 45° can be used when compared to 90° angled screws, for the mandibular angle region a plate positioned on the superior-lateral aspect of the external oblique ridge (to co-inside with the known strain lines) at screw angles of 60° or 45° have a longer travel distance through mono-cortex (Table 17 – for ISI of 60°: 0.63 – 1.08mm and for ISI of 45°: 1.69 – 2.89mm). Lag screws of 9-11mm are possible due to the plate position lateral and very superior on the external oblique ridge – the anatomy here demonstrates dense cortical bone with the medullary component more inferior and thus creates lag potential in cortex for a travel distance of 9-11mm the screw travel does not transect cancellous bone at all. A screw will have to be in place, one on each side of the fracture line, before insertion of the lag screw through the plate hole close to the fracture line in order to prevent fracture fragment separation.

7.2 Recommendations for future biomechanical stability investigation and geometrical design aspects of the ISI (inclined screw insertion) systems

7.2.1 Increased sample size

Increase of the sample size to at least $n = 30$ for each angle group in order to confirm significance ($p < 0.05$) when comparing ISI stability differences.

7.2.2 Plate Design

Outer cortex destruction of the polyurethane material can be prevented by designing experimental ISI plates with longer bridging segments. A bridging segment of at least 4mm would distance the plate hole (Figure 39 - distance XF), nearest the fracture-gap, sufficiently to permit pilot drilling for angled screw placement at angle 45° without destruction or load fracturing the bridge between fracture line and screw. (Figure 45).

7.2.3 The smart lock technology incorporated in ISI plate designs for the future

Apart from having a specific screw design the lock technology, presently marketed, permits screw placement at an angle variation of 10 degrees from the conventional 90° angled plate hole (Figure 46). The smart lock plating systems are designed and manufactured by Stryker/Leibinger and have the advantage of locking bone segments to the plate and rendering them more stable.

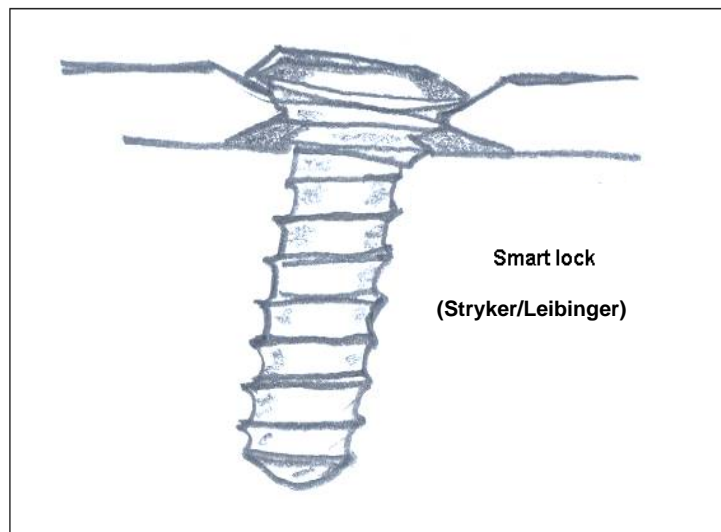

Figure 45: Screw angle variation of 10° from 90°

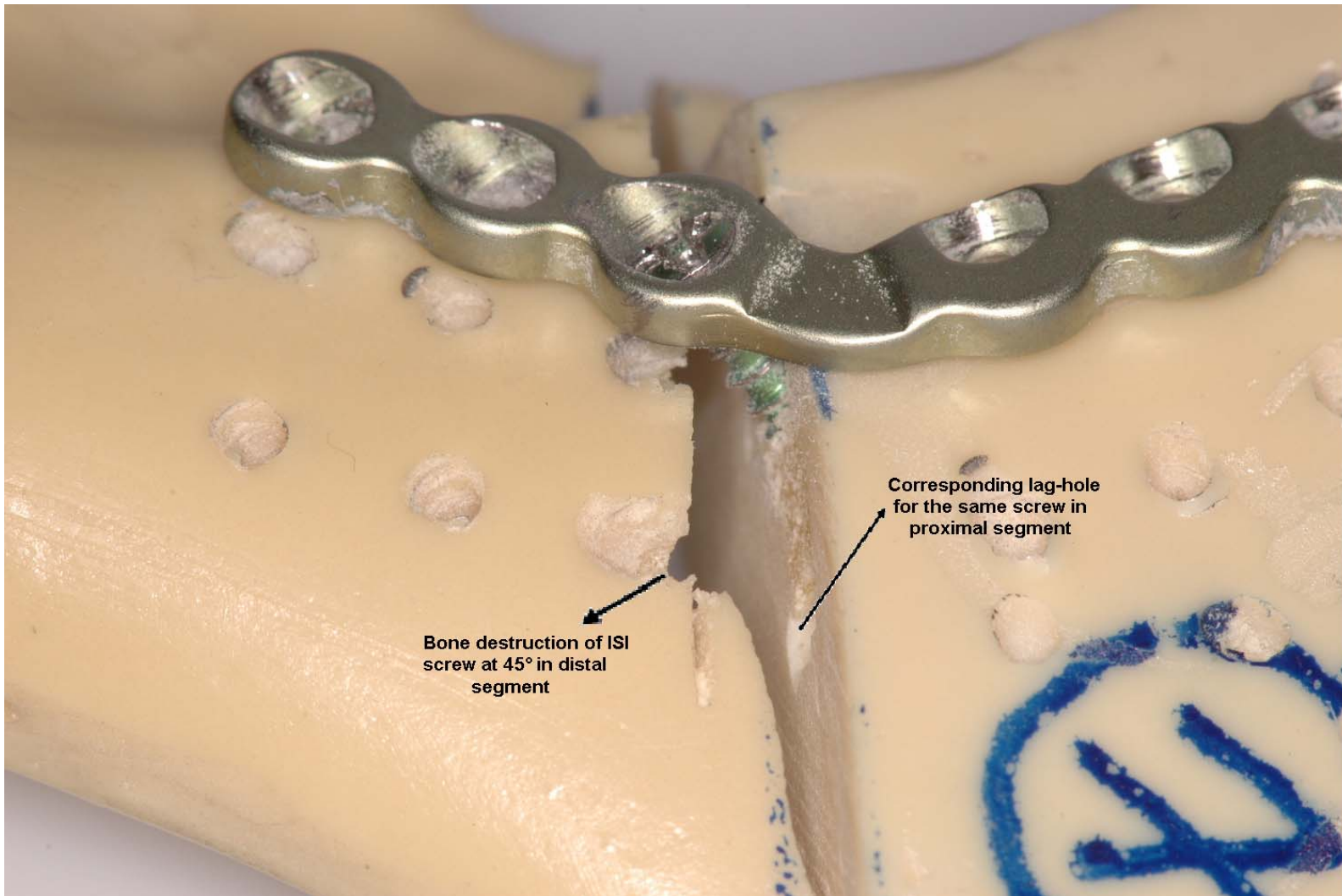

Figure 46: Bone destruction related to ISI of 45° for lag screw

An angle variation of 10-degrees, an inclined screw insertion angle of 80-degrees, is insufficient in terms of STT (screw tip travel) and STS (screw tip shifting) to promote lagging (transecting) across a fracture or osteotomy line (Figure 39).

It can be expected that orientation of screw angle within quadrant 1, 2, 3 or 4 as illustrated in Figure 1 in a plate hole, when applied differently in consecutive sets of angled plate-holes will change the spatial orientation of the screws in bone to benefit biomechanical stability. It is suggested that a plate should be manufactured with plate-holes designed according to the smart-lock principle. The plate-holes should be angled at a 55° (not 90°) in more than one quadrant orientation for screw insertion in the same hole. The smart lock ridge within the plate-hole will allow a 10° angle variation in screw angle placement. The variation of $\pm 10^\circ$ will permit screw placement at 65-45° in either quadrants 3 or 1 for the same plate-hole and allow the ISI plate. Quadrants 1&3 would be designated for use in the left half of the mandibular as apposed to the right half of the mandibular if the quadrant orientation were to be in quadrants 2&3. Screws placed at 90° angles to the bone surface, by contrast, have the same spatial orientation and can never be ideally angled to an oblique fracture line (Figure 5 A and B).

Tissue retractability and bone morphology at a specific anatomical site will determine plate-hole design and direct line of sight will dictate the quadrant orientation for plate-hole, pilot-hole and subsequent screw placement.

It is recommended that a “smart-lock” principle application could reduce the plate profile and in a 55° angled plate hole, will allow placement for screw variation within 10° accuracy, between 65° and 45° without the aid of a drill guide. The clinical relevance of ISI based on the “smart-lock” principle would allow screw locking and screw angle deviation between 45° and 65° without use of a drill guide and render biomechanical more stable fixation with minimal tissue tension using a direct line-of-vision for drilling or screw application without use of transbuccal or stab incisions.

Geometry of plate designs for angled screw insertion will be shaped specifically for an intended anatomical site and will have right sided and left side application versions and cannot be produced as standard straight plates as they do not conform to the stress lines for all possible anatomical sites.

7.2.4 Additional Instrumentation

Holding and drill guide instrumentation should be of low profile and will not aid in exact screw hole angle drilling unless accommodated by tissue retraction, which for intra-oral application is very limiting. Early product surveillance of a drill-guide /holding device proved it to be insufficient but pilot drilling without it was possible due to direct line of sight drilling in the angled plate-hole. Angled screw seating need not be exact when smart-lock screws and plate-hole designs are used as it allows a ten degree deviation.

The surgical intra-oral technique for ISI requires a certain amount of tissue retractability in the region of application. The direct line of application has a distinct advantage above trans-buccal or angled screwdriver applications (Figure 3).

7.2.5 Plate Geometry Related To Anatomical Positioning

Positioning and shape of osteosynthesis devices are important in creating biomechanical stability for fracture or osteotomy fragments.

An anatomical topographic study, similar to that conducted for the ISI plate should be the bases to contribute and dictate the geometric design of new plates conforming to existing strain lines as is the case in the marketed ISI plate with the plate hole angle orientation varied in the upper and lower sections of the plate – quadrant 1 for the ramus (upper) section and quadrant 3 in the corpus (lower) section of the curved shape of the ISI plate to adapt to the surgical angle of the mandible. Future plate designs for specific anatomical fracture positions in the mandible should also conform to the topographical aspects and accommodate structures such as the mental nerve.

A specific inverted Omega plate design (Addendum 6) to circumvent the mental nerve at the mental foramen with angled plate holes orientated in quadrant one (1) screws angled from front to back, clear of the nerve and with lag potential (Figure 47).

A y-shaped plate design for angle fractures will combine the effects of a superior border and lateral mono-cortical plate in a bi-planar fashion and will define a new term “bi-planar, mono-plating” (Figure 48). The geometry conforms to the strain lines during function and the tensile strains will be transmitted from superior arm to lateral/inferior

arm of the plate conforming to the mandibular angle anatomy and will resist torsion forces better than a single superior border plate.

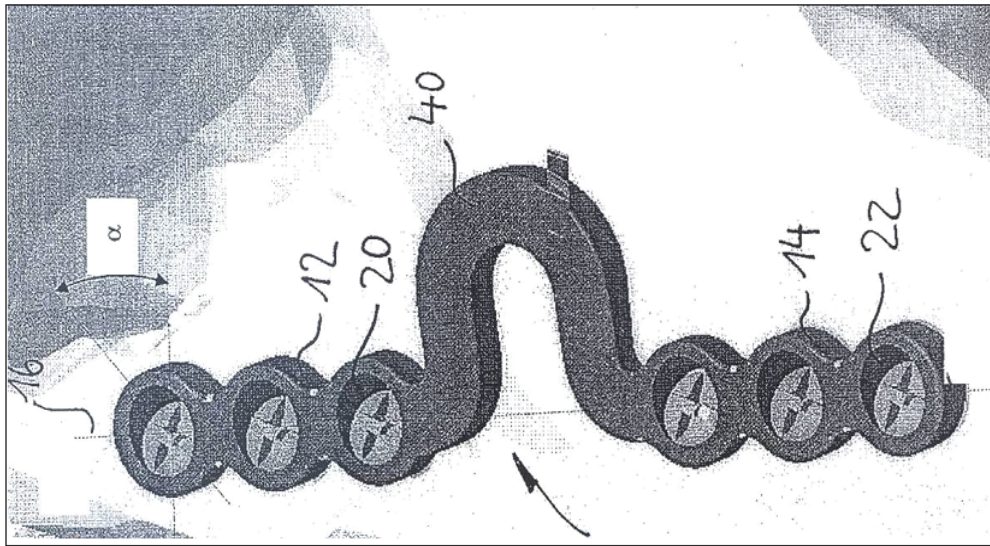

Figure 47: Inverted omega plate around Foramen mentalis

The mandibular angle y-shaped plate has a specific geometry to correspond with the strain lines in the mandibular angle (one strut for the superior border and the other for the lateral aspect of the external oblique ridge).

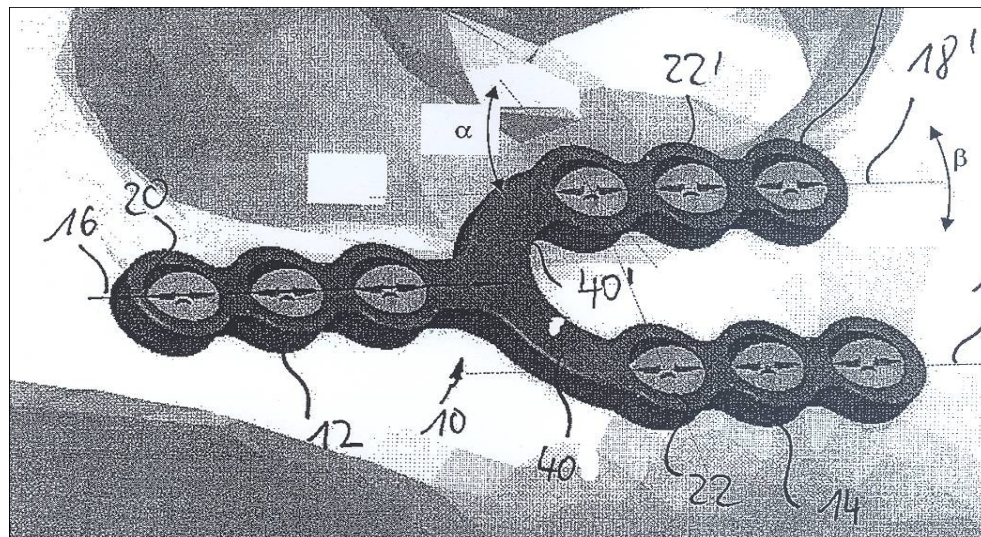

Figure 48: Y-shaped bi-planar mono-plate

There is a distinct demand to change the plate geometry to coincide with the strain lines (Figure 49) such is the case with the C-shape ISI plate along the ideal osteosynthesis lines in the mandible according to the functionally stable plating principles.

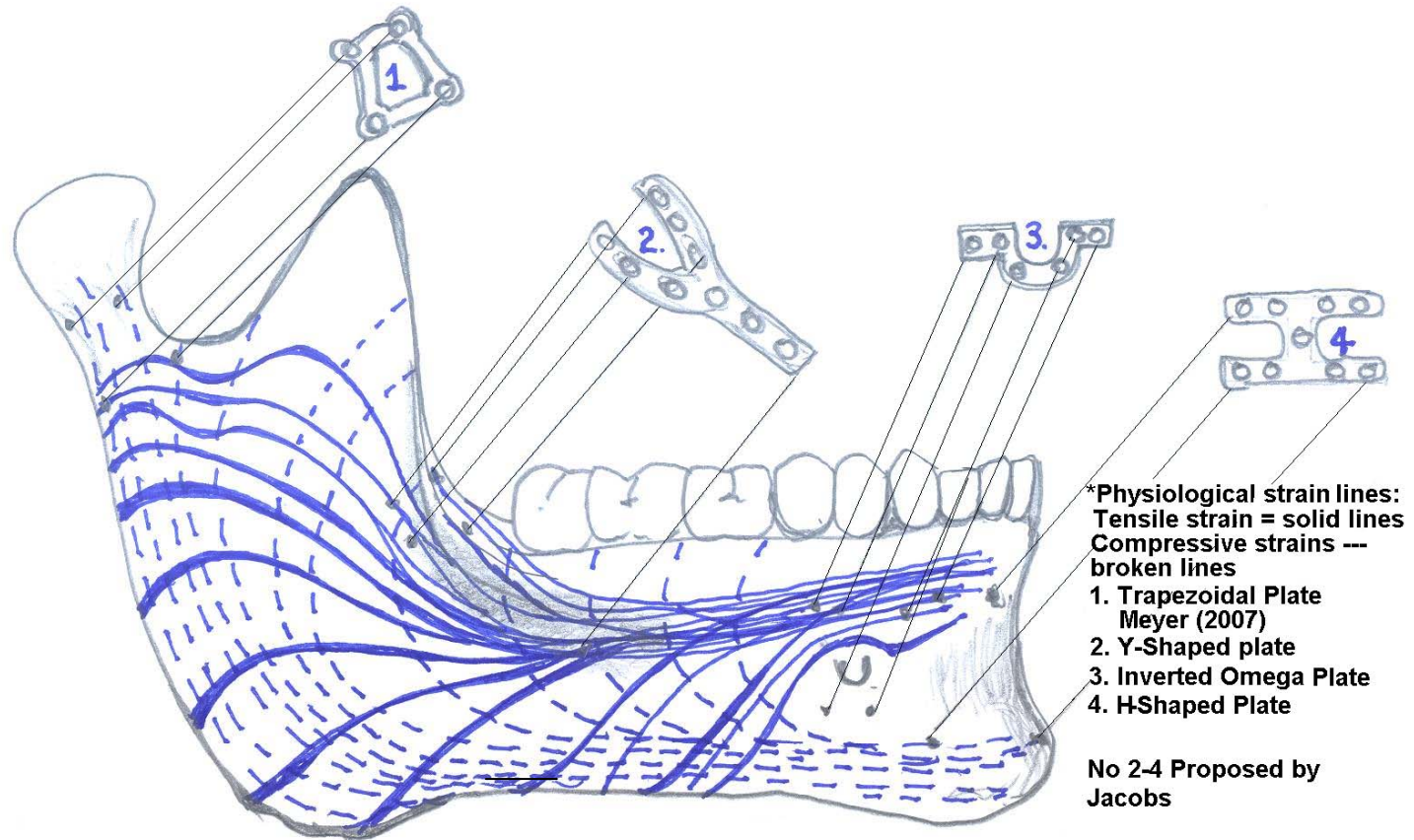

Figure 49: Proposed geometric designs according to physiological strain lines

Angled screw application with different orientation quadrants as in the patented ISI plate should be bio-mechanically compared to other mono-cortical conventional rectangular screw plates placed in a bi-plating, bi-planar or bi-plating mono-planar fashion as is the case with present research, mostly *in vitro* studies.^{18 - 20} Ideally a clinical prospective study would confirm clinical relevance, at present the only study of this nature demonstrated clearly that bi-plating for angle fractures had no proven benefit to the patients.³⁹

The angled screw and plate hole can be applied in any plate geometry such as the 2.0mm three-dimensional curved angle strut plate,³⁰ by changing its geometry to a Y-Shape to conform with strain lines during function at the mandibular angle (Figure 49). Angled screw application will benefit any mono- or bi-cortical plating system if designed specifically to conform with a certain anatomical topographical area of interest where strain lines are taken into consideration to conform to the established principles of functional osteo-synthesis. The plate shape will be unique and the angles of the plate-holes ideally inclined at between 65° - 45° angles of insertion and orientated in a specific quadrant (Figure 1), either parallel to the long-axis of the plate or diagonal (coronal) to it. The specific quadrant will align the screw angle diagonal to the fracture line and orientate the screw for lagging, across the fragments (Figure 50).

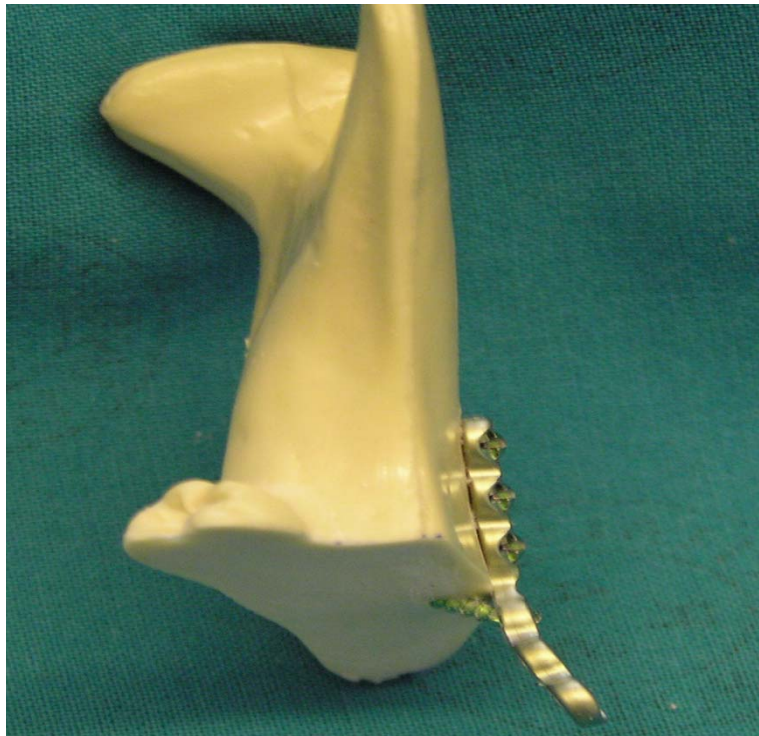

Figure 50: Lag effect of ISI at 45°

7.2.6 Plate Geometry, Functional Stable Osteosynthesis and Strain lines

Square and rectangular three-dimensional plates were introduced⁴⁰ to the market and it was demonstrated by Meyer⁴¹ that, three-dimensional rectangular plates provided the best biomechanical stability for sub-condylar fractures as a near perfect design, however, not completely conforming to the principles of functional stable osteosynthesis as advocated by Champy.^{3, 18}

The tensile strain lines for the sigmoid notch area, running parallel to the curvature of the notch, were defined and described by Meyer,⁴² from this information a trapezoidal three-dimensional 4-hole and 9-hole, condylar fracture mini-plate was designed. The plate geometry conformed to normal strain lines under function for the mandible, but do not accommodate inclined screw insertion to benefit a submandibular or temporal surgical approach to condyle neck fractures of the mandible.

The motivation to move away from near-perfect plate geometry, straight and three-dimensional plates on the market at present, a specific plate geometry for a specific anatomical area should be designed to conform with the normal strain lines in a specific fracture situation. Inclined Screw Insertion (ISI) will further benefit biomechanical stability and promote lagging across fracture lines through the principles of Screw Tip Shifting and Travel, in the mandibular angle and symphysis region. The plate geometry should accommodate the mental nerve and straddle the angle of the mandible in two planes – superior and lateral to the external oblique ridge rendering it more stable to lateral (torsion) forces of displacement.

Plate-hole angulations in quadrants 1&3 will ensure intra-oral surgical technique for application and removal of angled screws, through a direct line of vision without the use of a trans-cutaneous technique.

Straight plates fixed in different positions along ideal lines of osteosynthesis are inferior solutions to optimal screw angled plates of specific geometry for optimal biomechanical stability. Newly designed plates with the geometry conforming to functional strain lines will result in a reduction in the amount of implant material and number of screws used and would benefit patients treated due to biomechanical stability.

A y-shaped plate design for angle fractures will combine the effects of a superior border and lateral mono-cortical plate in a bi-planar fashion and will define a new term “bi-planar, mono-plating” (Figure 49). The geometry conforms to the strain lines during function and the tensile strains will be transmitted from superior arm to lateral/inferior arm of the plate conforming to the mandibular angle anatomy and will resist torsion forces better than a single superior border plate.

7.2.7 ISI – Quadrant Orientation and Lag-Effect of ISI

Mandibular angle fractures could benefit from angled screw hole plate designs when plating the lateral aspect of the ramus, high up on the caudal aspect of the external oblique ridge of which the patent ISI plate is an example. The ISI plate has 60° angled plate holes orientated differently for the plate holes in the proximal and distal segments to facilitate direct line of vision, intra-oral application and has improved biomechanical stability as demonstrated by comparative studies in the Mandibulator (Addendum 4).

Superior border plating according to the principles of Champy³ will benefit from lagging (Figure 50) of the screw adjacent to the fracture line with a screw angle orientated in quadrant 3 (Figure 1), parallel to the long-axis, for 4 or 6 - whole application, this will result in a lag-plate design with an expected three-dimensional biomechanical stability improvement.

A lag-screw, mono-cortical plate to the benefit of symphysis fractures should be designed based on ISI principles with plate geometry H-shaped and aligned according to functional strain lines for the specific anatomical site (Figure 49).

Plate geometry has to conform to physiological strain lines and be specifically designed, for a designated anatomical location, would have Inclined Screw Insertion (ISI) with a specific quadrant screw angle orientation to facilitate intra-oral surgical technique to have a direct line of vision for screw and drill application to accommodate a specific extra or intra-oral surgical approach. The specific angle of screw insertion would also promote lagging in the regions of the symphysis and angle of the mandible - these plates will be lag plates with superior biomechanical properties. The only plate recently designed for the market with a geometry which conforms to strain lines in the mandible is trapezoidal in shape and is proposed for the treatment of sub-condylar fractures.⁴² The plate geometry designs, as suggested, conform to strain lines and have inclined plate-holes, orientated in

specific quadrants for a screw angle placement of 45°-65° (the freedom of angle created by the smart-lock principle without use of a drill-guide) to promote lagging through a intra-oral application for plate 2 and 3 (Figure 49). The quadrant orientation of the plate-hole and screw-angles are quadrants 3 for plate Nos. 2 and 4 and quadrant 1, for plate No. 3. The plate geometries for ISI titanium fixation mini plates co-inside with ideal lines for osteo-synthesis, enhance biomechanical stability and is applied through a intra-oral surgical technique establishing it as a cost effective treatment modality for fracture or osteotomy segments.

The clinical significance of angled screw insertion for the ramus section of a reconstruction plate, lag-plating in the symphysis, mandibular angle and in condyle fracture plates is of high clinical and biomechanical significance.

The lower limit for inclined screw insertion would be an angle of 45° and it is proven that an angle of 30° would result in plate lifting (Figure 39).

It is also proven that a screw angle application of 75° due to minimal screw-tip shifting and travel (Figure 39) would have no significant benefit when compared to conventional rectangular screw insertion and has no transecting (“lag”) potential. A same screw application distance of at least 5mm from the fracture line for inclined screw insertion is defined in order to prevent pilot drill destruction of the outer cortical plate or screw tearing through the cortex as seen during experimentation with ISI angles of 60° and 45° using the experimental ISI prototype plates (Figure 32).

The difference in the experimental ISI plate design and the clinical patentable ISI prototype used in the EPS (early product surveillance) is a longer connecting bar between the upper and lower plate-holes to prevent pilot drill destruction and/or subsequent tearing of the screw through the cortex on the edge of the fracture line when force is applied (Addendum 5).

If Inclined Angle Screw Insertion (ISI) is applied in a clinical situation the screw transection across the fracture line (“lagging”) results in significant and dramatic biomechanical stability improvement of the fixation provided that screw-tearing or pilot drill destruction of the outer cortex is prevented (Figure 45) by means of the ideal plate design (see point D and distance X E in Figure 39). Screw “lagging” is possible for ISI in quadrant three (Figure 50), with the optimal line sight for direct drilling. ISI in quadrant one is aimed at the engagement of thicker bone on the lower

border of the mandibula in the symphysis regions. The freedom created by ISI and pilot drilling at what you see through the plate hole will have the advantage of not using a drill guide.

7.3 The anatomical study related to the geometric ISI plate design

Measurement of the surgical angle in a sample of human South African dried mandibles was performed to determine the geometry of the ISI plate for internal fixation in the mandibular angle region.

The curved shape of the ISI miniplate has to conform to the surgical angle of the mandible⁴³ (The angle formed by the anterior border of the ramus of the mandible and the external oblique ridge, is called the surgical angle of the mandible).

The superior border plate placement for angle fixation is considered to be just above and medial to the external oblique ridge in the retromolar fossa region, when this area could not be employed (ridge too narrow, impacted mandibular third molar, alveolar fracture, subject too young, etc.), the ISI plate is indicated and can be applied as high as possible on the lateral surface of the mandible just below the external oblique ridge (surgical angle). The retromolar fossa is defined as the triangular depression between the ridge called the temporal crest that runs from the tip of the coronoid process on its medial side to the bone just behind the third molar tooth and the anterior border of the ramus.

The ISI mini-plates are curved in a C shape to fit the surgical angle of the mandible. Measurement of the surgical angle is therefore essential to enable manufacturing of an universal fracture plate at the determined angle when applied to the angle of the mandible for fracture or osteotomy fixation. An universal C-shaped plate manufactured at the maximum determined surgical angle would be ideal to fit most fracture situations in the angle of the mandible if applied to the lateral aspect (Figure 51).

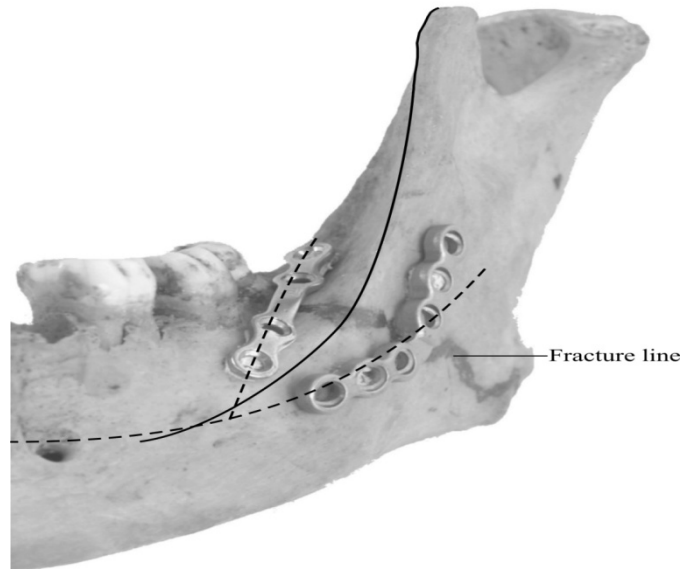

Figure 51: ISI plate geometry dictated by the surgical angle of the mandible

To the best of our knowledge, there is no record of an anatomical study determining the surgical angle of the mandible. The purpose of this anatomical study was to determine the surgical angle of the mandible, which has implications for the geometric design of the ideal angle of the C- shaped, curved ISI mini-plate positioned at the ventral (inferior- lateral) aspect of the external oblique ridge, on the same vertical plane.

A total of 133 human mandibles with intact first and second molars at least on one side, were randomly selected from the Pretoria Bone Collection: a modern South African skeletal sample (111 black males, 12 black females, 6 white males, and 4 white females) (Figure 52).

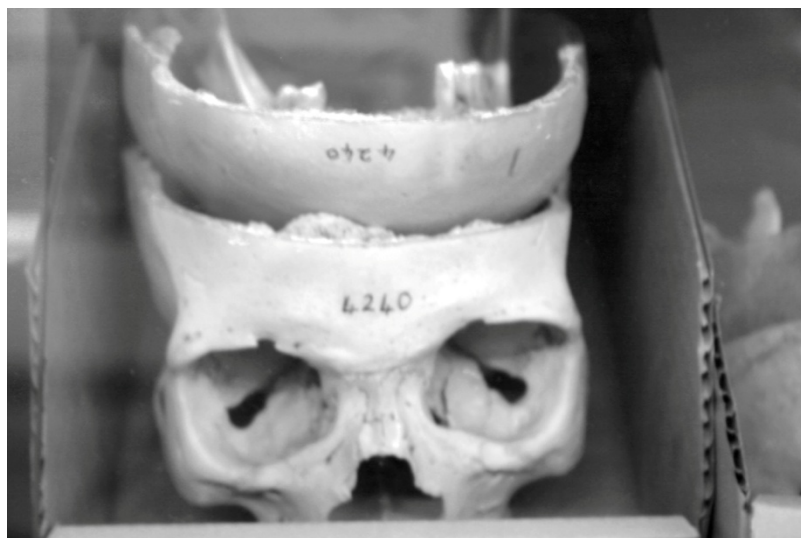

Figure 52: Sample of the Pretoria Bone Collection

The surgical angle was measured and expressed in degrees. The maximum angle measured was 150° , a plate manufactured at 150° or more obtuse will accommodate all the possible variations in our study group when applied to the lateral aspect of the mandible along and inferior to the surgical angle.

One hundred and eleven of the specimens belonged to black males, 12 to black females, six to white males, and four to white females. Their ages ranged between 23 and 87 years. Measurements were taken with a soft lead wire contoured along the anterior border of the ramus of the mandible through the most concave aspect of the surgical angle and continuous with the external oblique ridge, to a point coinciding with a perpendicular line drawn from the most posterior aspect of the first molar or the most anterior aspect of the second molar (Figure 53).



Figure 53: The right lateral aspect of the mandible.

The bold solid line indicates the placement of the wire along the surgical angle.

The contoured wire was traced onto paper. Point A was marked on this line – determined by a line drawn perpendicular from the posterior aspect of the 1st molar or anterior aspect of 2nd molar onto the point of intersection with the traced external oblique line. The extent of inversion of the external oblique ridge in a 2nd plane was measured as the vertical distance from the paper and the contoured wire in millimetres (mm) (Figure 54).



Figure 54: Soft wire contoured along the external oblique ridge, placed on a flat surface to reflect the amount of plate bending required.

A tangential line was drawn from point A to the coronoid process. The point of contact between the tangential line and the coronoid process was point C. From line AC, point B was established as the deepest point or most concave aspect of the surgical angle: in other words the largest distance from line AC. A triangle was constructed between ABC where angle B represented the surgical angle, which is the junction between the body of the mandible and the ramus at the origin of the external oblique line (Figure 55).

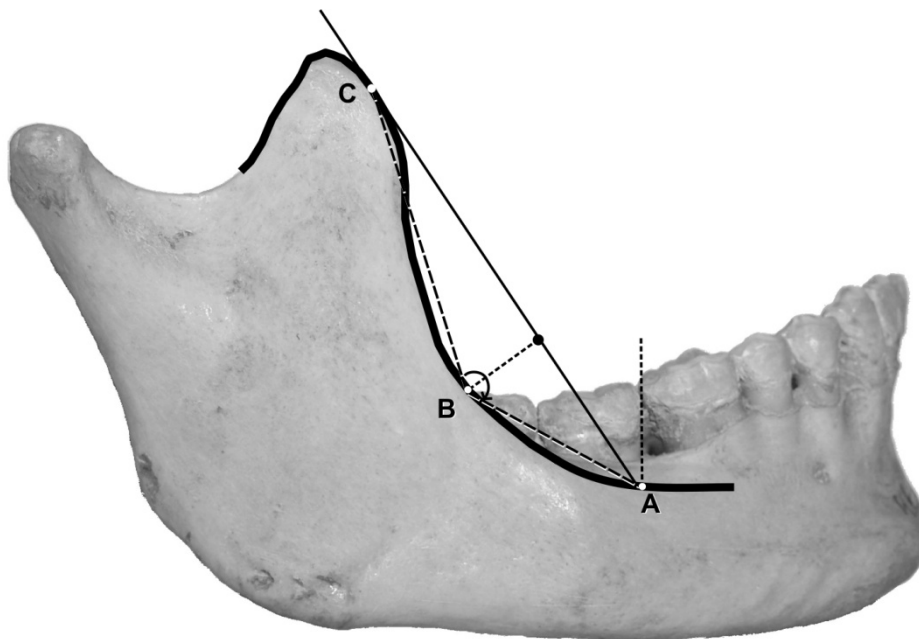

Figure 55: Trichonometrical calculation of the surgical angle

This angle represents the minimum angle at which a C-shaped plate is to be manufactured in order to fit the lateral aspect of the mandible below the external oblique ridge when treating mandible angle fractures. The mean and standard deviation were determined for all of the measurements. The one-way ANOVA with Scheffe and LSD as post hoc comparisons was calculated to determine whether the differences between the groups were statistically significant.

Two independent researchers were used to evaluate this unique, newly applied measurement method to evaluate surgical angle within the same sample of dried cadaver mandibles. The purpose was to correlate the repeatability of the measurement method. The inter-rater agreement or reliability between the measurements done by the two researchers was assessed by the interclass coefficient where each of the two researchers measured the surgical angle of 20 randomly selected mandibles. Only the black male group of 111 individuals was used for this analysis, as the other groups were too small to use for statistical purposes. The inter-rater agreement as measured by the interclass correlation coefficient was found to be 0.997, which suggests almost perfect agreement. It further suggests that the test procedure is highly repeatable and measurements by these two researchers are interchangeable.

A one-way ANOVA was computed to detect significant differences if any between the mean measurements of the four population groups. No statistical significant difference between the measurements of the surgical angle amongst the population groups and sexes could be demonstrated. Although not all the groups were well represented, there was a statistical significant difference between the average ages of blacks (males and females) and white females, which were much older. In addition there was a statistical significant difference between the average ages of black females and white males. The average surgical angle of the white female group was larger than those of the others, although not significantly different.

The result of the surgical angle measurement obtained is summarized in table 18.

Table 18: Tabulation of the average age, surgical angle and maximum angle measured in degrees, of the various population and sex groups. The standard deviation (SD) is given in brackets in each case.

	Population group	Average age in years	Average surgical angle in degrees	Maximum angle measured
Surgical angle	Black males (n=111)	54.14	137.30 (6.31)	150
	Black females (n=12)	46.83	136.08 (4.32)	144
	White males (n=6)	61.17	137.83 (3.92)	144
	White females (n=4)	71.25	142.50 (4.2)	148
	All (n=133)	54.32	137.38 (6.06)	150

An universal C-shaped fracture plate (one plate fits all) manufactured at the maximum surgical angle measured, simplifies plate selection for the surgeon and results in cost savings. The average angle of 136.62 to 142.5° dictates that the universal plate should be manufactured at an angle more obtuse than 142.5° to accommodate most variations. As the maximum angle measured was 150°, a plate manufactured at 150° or more obtuse will accommodate all the possible variations in our study group when applied to the lateral aspect of the mandible along the surgical angle in treatment of mandibular angle fractures.

The amount of inversion of the external oblique ridge reflects the amount of bending required to contour the curved mini-plate to the lateral aspect of the mandible. This is of value so as to indicate the degree of rigidity (resistance to bending without stability compromise) of the plate needed for ease of handling by the surgeon. In our study we found that the average amount of inversion of the external oblique ridge, and thus bending required from the curved mini-plate, was 2.83 mm.

Although the sample does represent very low numbers in the female groups and white males, it is well represented in the black male group. Measurements of the surgical angle in black males are particularly relevant to the population group in our care. According to personal experience of fractured mandibles in our department, there is a predominance of black male cases, which gives credibility to this study.

The white female group, only represented here with four members, had a larger average surgical angle and was significantly older than the other groups. The relationship between age and surgical angle has not been fully investigated in this study.

It can be concluded that the maximum surgical angle measured in this sample of mandibles from the Pretoria Bone Collection was 150°. An universal plate manufactured at 150° or more obtuse will accommodate all the possible variations in our study group when applied to the lateral aspect of the mandible along the surgical angle in treatment of mandibular angle fractures. Further studies may be conducted to improve the numbers in the groups not well represented. The relationship between age and surgical angle should be further analyzed.

7.4 Surgical technique for ISI plate fixation.

The operative technique instructions below for the patented ISI plate is summarized in the surgeon's manual as developed through this research.

CHAPTER 8 CONCLUSION

The scientific contribution of the ISI principle

A six-hole mono-cortical trauma plate with angled plate holes, in different angle quadrant orientations for each segment was designed and tested as an unique patentable concept, applied trans-orally at the ventral aspect of the external oblique line defined as a Champy strain line in the angle of mandibula.

ISI (Inclined Screw Insertion) is clinically defined in terms of screw tip travel (STT- with clinical relevance to screw length) and screw tip shifting (STS with clinical relevance to the lag-potential of a screw) as new terminology used to implicate improved biomechanical stability compared to 90⁰-angled conventional screw insertion.

New designs of plate geometry for application to specific anatomical regions of the mandibula are suggested (Addendum 6). The designs are dictated by the known strain lines of the mandibula during function and aimed at using a single plate with a specific geometry rather than several straight plates to cover the strain lines. This approach is more cost effective and minimises the amount of titanium used. This design is developed for an intra-oral application and therefore a transbuccal approach is not required.

A quadrant description for angled screw placement is formulated to benefit future communication in terms of plate-hole and screw angle orientation and to standardise terminology.

Presently there is no angled screw plating system on the market which opens a vast unexplored field of investigations to be attended to. Comparative biomechanical studies can now be restricted to application angles of between 65°- 45° angles based on the findings of this study.

Angled screw application in a mono-or bi-cortical plating system will clinically render superior biomechanical stability to conventional 90⁰ angled screw systems. This unique biomechanical study establishes new concepts in terms of inclined screw insertion (ISI), torsion screw angle test (TSAT), compression screw angle test (CSAT), screw tip shifting (STS), and screw tip travel (STT).

An unique biomechanical stability testing device is designed and manufactured to investigate the in vitro efficacy of rigid fixation systems with high clinical relevance

and significance when applying compression, tension and torsion forces to fracture simulations in synthetic polyurethane mandibula replicas. This device proved efficient and cost effective during biomechanical testing as the only available stability testing device in South Africa for future *in vitro* studies.

ANNEXURE 1: REFERENCES

1. Haug, R.H., Barber, J.E. and Reifeis, R. A comparison of mandibular angle fracture plating techniques. *Oral Surg Oral Med Oral Pathol Oral Radio Endod* 1996[82]257-263.
2. Haug, R.H., Nuveen, F.J., Barber, J.E. and Storoe, W. An *in vitro* evaluation of distractors used for osteogenesis. *Oral Surg Oral Med Oral Pathol Oral Radio Endod* 1998[86]648-659.
3. Champy, M., Loddé, J.P., Schmitt, R., Jaeger, J.H. and Muster, D. Mandibular osteosynthesis by miniature screwed plates via a buccal approach. *J Maxillofac Surg* 1978[6]14-21.
4. Michelet, F.X., Deymes, J. and Dessus, B. Osteosynthesis with miniaturized screw plates in maxillofacial surgery. *J Maxillofac Surg* 1973[1]79-84.
5. Dichard, A. and Klotch, D.W. Testing biomechanical strength of repairs for the mandibular angle fracture. *Laryng* 1994[104]201-208.
6. Schierle, H.P., Schmelzeisen, R. and Rahn, B. Experimentelle Untersuchungen zur biomechanischen Stabilität unterschiedlicher Miniplattenkonfigurationen am Kieferwinkel. *Fortschr Kiefer Gesichtschir* 1996[41]166-170.
7. Vollmer, D., Meyer, U., Vegh, A. and Piffko J. Experimental and finite element study of a human mandible. *J Cranio-Maxillofac Surg* 2000[28]91-96.
8. Tate, G.S, Ellis E. and Throckmorton, G.S. Bite forces in patients treated for mandibular angle fractures. *J Oral Maxillofac Surg* 1994[52]734-736.
9. Ellis, E. Throckmorton, G.S. and Sinn, D.P. Bite forces before and after surgical correction of mandibular prognathism. *J Oral Maxillofac Surg* 1996[54]176-181.
10. Throckmorton, G.S., Buschang, P.H. and Ellis, III, E. Improvement of maximum occlusal forces after orthognatic surgery. *J Oral Maxillofac Surg* 1996[54]1080-1086.
11. Harada, K., Watanabe, M., Ohkura, K. and Enomoto, S. Measure of bite force and occlusal contact area before and after bilateral sagittal split ramus osteotomy of the mandible using a new pressure-sensitive device. A preliminary report. *J Oral Maxillofac Surg* 2000[58]370-373.
12. Shetty, V., McBrearty, D, Fourney, M. Caputo, A.A., Champy, M. and Kahn, J.L. Fracture line stability as a function of the internal fixation system: An *in vitro* comparison using a mandibular angle fracture model. *J Oral Maxillofac Surg* 1995[53]791-802.
13. Bütow, K.-W. Titanium-titanium nitride temporomandibular joint prosthesis: Clinical application and 5-year assessment. *J Cranio Max-Fac Surg* 1998[26](Suppl.1)25.

14. Kroon, F.H.M., Mathisson, M., Cordy, J.R. and Rahn, B.A. The use of miniplates in mandibular fractures – an *in vitro* study. *J Cranio-Maxillofac Surg* 1991[19]199-204.
15. Barry, C.P. and Kearns, G.J. Superior border plating technique in the management of isolated mandibular angle fractures: A retrospective study of 50 consecutive patients. *J Maxillofac Surg* 2007[65]1544-1549.
16. Scurry, Jr., W.C., Beus, K.S., Mc Ginn, J. and Fedok, F.G. Operative time analysis of miniplate fixation of the mandible. *Fac Pl Surg* 2005[21]176-179.
17. Ellis, E., Waler, L. and Shafer, D. Treatment of mandibular angle fractures using two noncompression miniplates. *J Oral Maxillofac Surg* 1994[52]1032-1037.
18. Ellis, E. Treatment methods for fractures of the mandibular angle. *J Cr-Maxillofac Tr* 1997[2]28-36.
19. Siddiqui, A., Markose, G., Moos, K.F., McMahon, J. and Ayoub, A.F. One miniplate versus two in the management of mandibular angle fractures: A prospective randomised study. *Brit J Oral Max Fac Surg* 2007[45]223-225.
20. Schierle, H.P., Schmelzeisen, R., Rahn, B. and Pytlik, C. One- or two-plate fixation of mandibular angle fractures. *J Cranio-maxillofac Surg* 1997[25]162-168.
21. Gerlach, K.L. and Schwarz, A. Bite forces in patients after treatment of mandibular angle fractures with miniplate osteosynthesis according to Champy. *Int J Oral Max Fac Surg* 2002[31]345-348.
22. Gerlach, K.L. and Schwarz, A. Load resistance of mandibular angle fractures treated with a miniplate osteosynthesis. *Mund-Kiefer-Heilkunde* 2003[7]241-245.
23. Schlicke, L.H., Penjabi, M.M. and White, A.A. Optimal orientation of transfixation screws across oblique fracture lines. *Ci Orthop* 1979[143]271-277.
24. Krenkel, C. Axial “anchor” screw (lag screw with biconcave washer) or “slanted-screw” plate for osteosynthesis of fractures of the mandibular condylar process. *J Maxillofac Surg* 1992[20]348-353.
25. Meyer, C., Zink, S., Chatalane, B. And Wilk, A clinical experience with osteosynthesis of subcondylar fractures of the mandible using TCP plates. *J Cranio-Maxillofac Surg* 2008[36] ; 260-268.
26. Jacobs, F.J. and Botha, S.J. The minimal invasive mono-cortical angle system, MIMAS. *Int J Oral Maxillo-Fac Surg* 2003[32][Suppl 1 & 2].
27. Smith, B.R., Rachel, J.L., Waite, D.E. and Read, L. Mandibular anatomy as it relates to rigid fixation of the sagittal split ramus osteotomy. *J Oral Maxillofac Surg* 1991[49]222-226.

28. Heibel, H., Alt, K.W., Wächter, R. and Bähr, W. Cortical thickness of the mandible with special reference to miniplate osteosynthesis, Morphometric analysis of autopsy material. *Mund-, Kiefer- und Gesichtschir* 2001[5](3)180-185.
29. Toma, V.S., Mathog, R.H., Toma, R.S. and Meleca, R.J. Transoral versus extraoral reduction of mandible fractures: A comparison of complication rates and other factors. *Otolaryng Head and Neck Surg* 2003[128]215-219.
30. Guimond, C., Johnson, J.V. and Marchena, J.M. Fixation of mandibular angle fractures with a 2.0mm 3-dimensional curved angle strut plate. *J Oral Maxillofac Surg* 2005[63]209-214.
31. Uckan, S., Schwimmer, A., Kummer, F. and Greenberg, A.M. Effect of the angle of the screw on the stability of the mandibular sagittal split ramus osteotomy: A study in sheep mandibles. *Brit J Oral Maxillo-Fac Surg* 2001[39]266-269.
32. Jacobs, F.J. and Botha, S.J. 2004 Minimal-Invasive-Monocortical Angle system-load sharing load bearing forces. *J Dent Res* 83 (Special Issue B).
33. Haug, R. H., Fattahi, T.T. and Goltz M. A biomechanical evaluation of mandibular angle fracture plating techniques. *J Oral Maxillo-Fac Surg* 2001[59]1199-1210.
34. Feller, K.-U., Richter, G., Schneider, M. and Eckelt, U. Combination of microplate and mini-plate for osteosynthesis of mandibular fractures: An experimental study. *Int Oral Maxillo-Fac Surg* 2002[31] 78-83.
35. Krenkel, C. Biomechanics and osteosynthesis of condylar neck fractures of the mandible. Berlin: Quintessence; 1994; 57+151-152.
36. Zwang-Wei, W.U., Ya-Dong, Y.U., Zi-Ying, Qi-Lin, L.I.U. and Li-Ming, Y.U. Finite element analysis for tension band fixation of mandibular fractures. *J Jilin Uni (Med Ed)* 2006[32] (5)862-865.
37. Jacobs, F.J. and Botha, S.J. 2006 Minimal Invasive Mono-Cortical Angle System – Multiple Angle Application. *J Dent Res* 83 (Special Issue B).
38. Nissenbaum, M., Lownie, M. and Cleaton Jones, P. Relative displacement resistance of standard and low-profile bone plates in experimental mandibular angle fractures. *Oral Surg Oral Med Oral Path* 1997[83]427-432.
39. Arshad S., Markose, G. and Khursheed, F.M. One miniplate versus two in the management of mandibular angle fractures : A prospective randomised study. *J Oral Maxillo-Fac Surg* 2007[45]:223-225.
40. Farmand, M. and Dupoirieux, L. The value of 3-dimensional plates in maxillofacial surgery. *Rev Stomatol Chir Maxillofac* 1992 [93]353-357.
41. Meyer, C., Kahn, J.L., Boutemi, P. and Wilk, A. Photo elastic analysis of bone deformation in the region of mandibular Condyle during mastication. *J Cranio Maxillo-Fac Surg* 2002[30]160-169.
42. Meyer, C. Experimental evaluation of three osteosynthesis devices used for stabilizing condylar fractures of the mandible. *J Cranio-Max Fac Surg* 2006[34]173-181.
43. Rowe, N.I. and Williams, J.L. Maxillofacial Injuries. Edinburg London: Churchill Livingstone;1985; p10.



UNIVERSITEIT VAN PRETORIA
UNIVERSITY OF PRETORIA
YUNIBESITHI YA PRETORIA

Addendum 1: Pilot Study Proposal



UNIVERSITEIT VAN PRETORIA
UNIVERSITY OF PRETORIA
YUNIBESITHI YA PRETORIA



Centre for Integrated Sensing Systems

PROJECT PROPOSAL

ISP(2002)IC036

**Pilot Study on Mono-cortical Systems
used in Mandible Fractures**

Prepared for: Professor F.J. Jacobs
P.O. Box 915-1029
Faerie Glen
0043

Prepared by: C. Mc Duling
Manufacturing and Materials Technology, CSIR
P. O. Box 395
Pretoria
0001



DOCUMENT CONTROL

Degree of Confidentiality	:	Company Confidential
Title	:	Pilot Study on Mono-cortical System for Mandible Fractures
Author(s)	:	C. McDuling
Date of Issue	:	1 July 2002
Number of Pages	:	11
Issuing Organisation: Centre for Integrated Sensing Systems Sensing & Actuation PO Box 395 0001 Pretoria	Tel.:	(27 12) 841-2556
	Fax :	(27 12) 841-4038
CONTRACT NAME	:	Pilot Study on Mono-cortical System
PROJECT NUMBER	:	HAB04
KEYWORDS	:	Mono-cortical System Mandible Fractures
ISSUE NUMBER	:	1
COPY NUMBER	:	1, 2, 3
PREPARED BY	:	Chris McDuling
REVIEWED BY	:	D. Lindeque
Responsibility	Name	Signature
Project Leader	C. McDuling	
Business Area Manager	D. Lindeque	
Quality Management	A. Chaffey	
DISTRIBUTION		
Name	Designation	Copy Number
I&C Registry	Bld. 14 / E40	1 (Master Copy)
Prof. F.J. Jacobs	Faerie Glen	2
C. McDuling	Bld 14 / F	3



INDEX

EXECUTIVE SUMMARY	4
1. INTRODUCTION	5
2. APPROACH	5
3. OBJECTIVES	5
4. DETAILED SCOPE OF WORK	5
5. EXCLUSIONS	6
6. DELIVERABLES	6
7. COSTS	6
8. PAYMENT AND DELIVERY SCHEDULE	6
9. PROPOSAL VALIDITY	6
10. CSIR TEAM	6
11. PROPOSAL ACCEPTANCE	7
12. CSIR, DIVISION OF MANUFACTURING AND MATERIALS BANK ACCOUNT INFORMATION	7
13. CONTRACT CONDITIONS	7
APPENDIX 1 : ACCEPTANCE SHEET	8
APPENDIX 2 : GENERAL CONTRACT CONDITIONS	9



EXECUTIVE SUMMARY

Professor F.J. Jacobs approached the CSIR in connection with a pilot study on Mono-cortical Systems for mandible fractures. The approach would be to use two fixation methods on proximal segments of mandibles from sheep and to do mechanical tests in order to differentiate the strength of the two fixations. Each mandible will be divided in the anterior midline between the teeth and embedded in an acrylic resin. The mandible will then be installed in a test jig.

The objective would be to conduct a number of tests in different load applications in order to measure the consistency of each fixation method and to compare the results of the two methods during the same load application.

The load will be applied by means of an Instron universal servo hydraulic testing machine. The displacement of the fractured mandible at the fixation will be measured by means of a clip gauge installed in a transverse direction to the fracture. The load and displacement will be recorded and the results of each mandible with the two different fixations will be compared. A number of tests as required by Professor Jacobs will be conducted to vary the position of load application in order to measure the consistency of each fixation under different load conditions.

A comprehensive test report stating the testing methodology and test results will be issued once all the tests are completed.



1. INTRODUCTION

Professor F. J. Jacobs from MEDUNSA approached the CSIR in connection with a pilot study on Mono-cortical Systems for mandible fractures. Tests will be conducted at the mechanical testing laboratory of the CSIR on a number of sheep mandibles. Two fixation methods will be used in order to measure the difference in strength on the same mandible when subjected to the same loading conditions. The first fixation method consists of a mono-cortical conventional 2mm six-hole miniplate with screws placed at a 90° angle to the bone. The second method consists of a mono-cortical newly designed six-hole plate with screws inserted at an angle of 60° . In order to differentiate the strength of the two fixation methods, each mandible will be prepared with a 60° six-hole plate on the one side and a 90° six-hole plate on the other side of the mandible.

2. APPROACH

A number of sheep mandibles will be obtained by Professor Jacobs and prepared for test applications. A test jig will be manufactured by the CSIR to accommodate the mandible specimens. The fixation of the fractures and the embedding of the mandibles will be carried out by Professor Jacobs. The tests will be carried out in an Instron universal servo hydraulic testing machine and the load will be applied at a constant displacement rate. The displacement of the mandible at the fixation will be measured by means of a clip gauge attached to the mandible. The load and displacement will be recorded and the results of each mandible with the two different fixations will be compared.

3. OBJECTIVES

The objective would be to conduct a number of tests in different load applications in order to measure the consistency of each fixation method and to compare the results of the two methods during the same load application.

4. DETAILED SCOPE OF WORK

4.1 Specimen Preparation

4.1.1 The test specimens will be prepared and delivered to the CSIR test facility by Professor Jacobs.

4.1.2 Modifications to accommodate the test specimens in the test jig will be made at the testing laboratory once the first sample is delivered.

4.2 Test Criteria

The number of tests will be determined by the consistency of the test results and the variation of the position where the load is applied.



5. EXCLUSIONS

- 5.1 The CSIR takes no responsibility for the applicability of the test conditions to real life operating characteristics of the product.
- 5.2 The CSIR cannot be held responsible for any failure or consequential damage resulting from such failure.

6. DELIVERABLES

A final test report will be compiled after completion of the last test.

7. COSTS

- 7.1 Manufacturing of Test Jig: R2200-00
- 7.2 Testing:
- a) Set-up & preparations per test series: R350-00
 - b) Testing per load application: R475-00
- 7.3 Test Report: R500-00

8. PAYMENT AND DELIVERY SCHEDULE

Payment covering the total cost will be 30 days after invoice and VAT is not included in the above quoted costs.

Delivery of the final test report will be made ten working days after last test.

9. PROPOSAL VALIDITY

This proposal is valid for 30 days, after which time it will be subject to review.

10. CSIR TEAM

Your contact persons at CSIR Manufacturing and Materials Division are:

Chris Mc Duling	Project Leader	(012) 841-4226
Dirk Lindeque	Business Area Manager	(012) 841-4436
Werner Merbold	Centre Manager	(012) 841-2696



11. PROPOSAL ACCEPTANCE

To accept this proposal, please sign the Acceptance Sheet, and fax it to Manufacturing & Materials, CSIR together with your order.

12. CSIR, DIVISION OF MANUFACTURING AND MATERIALS BANK ACCOUNT INFORMATION

Branch: ABSA Bank Lynnwood, P O Box 35504
Account No.: 540002304
Branch Code: 33474510

13. CONTRACT CONDITIONS

The attached CSIR General Conditions, Appendix 2, applies to the work to be carried out under this quotation. Acceptance of the quotation implies acceptance of the conditions.



UNIVERSITEIT VAN PRETORIA
UNIVERSITY OF PRETORIA
YUNIBESITHI YA PRETORIA

Addendum 2: Research Protocol



UNIVERSITEIT VAN PRETORIA
UNIVERSITY OF PRETORIA
YUNIBESITHI YA PRETORIA

University of Pretoria



Research Protocol

Name: Prof. Frederick J Jacobs

Address: 313 Vista Drive
Fairie Glen
Pretoria
0043

Department: Maxillo-Facial Oral and Surgery

Proposed Degree: Protocol/Thesis to be submitted in fulfilment of the requirements for the degree of PhD

Title of Thesis: The effect of innovative screw angled mini-plates on biomechanical stability of mono-cortical fixation-an in vitro model

Promotor: Prof Kurt-W Bütow
Head, Department of Maxillo-Facial Oral and Surgery

Examiners:
Internal: Prof Kurt-W Bütow
Department of Maxillo-Facial Oral and Surgery
Faculty of Health Sciences
School of Dentistry
University of Pretoria

Date: 16th May 2005

1. THESIS TITLE

The effect of innovative screw angled mini-plates on biomechanical stability of mono-cortical fixation- an in vitro model.

2. PURPOSE

The purpose of this study is to introduce a testing device and a less complex scientifically relevant method of investigating the biomechanical behaviour of mono-cortical mandibular fragment fixation at different screw angles.

3. AIM

The aim of this investigation is:

- The development and fabrication of a testing device to evaluate 3-dimensional “in vitro” stability of mini-plate fixation of the mandible which emulates clinical relevance.
- To determine and quantify the efficacy of biomechanical stability of mono-cortical fixation employing mini-plates designed to accommodate a screw-placement angle of 90° (control) and design innovations featuring screw-placement angles of 45°, 60° and 75° respectively. These fixation displacement characteristics will be assessed in tension, compression and torque modes of loading.
- To compare and reflect significant differences in the flexural data obtained from the various fixation systems.

4. BACKGROUND

Mini-plate fixation of displaced fractures was advocated by Roberts in 1964.¹ During the ensuing decades, mini-plate fixation techniques, without intermaxillary fixation, evolved as a consequence of the delineation of the intrinsic anatomy and biomechanical principles associated with deformation of the mandible in function.^{2,3}

The development and construction of the 3-dimensional testing device should simplify technically challenging procedures presently employed for accurate assessment of biomechanical stability of mandibular fixation systems.

The efficacy of biomechanical stability of mono-cortical fixation, when subjected to tensile, compressive and torsional modes of loading, should exhibit similar load displacement characteristics for both the conventional 90°, as well as the experimental screw plate designs featuring more acute placement angulations.

The innovative design configurations proposed for evaluation, should be clinically relevant.

4.1 ANATOMICAL CONSIDERATIONS

Viable surgical procedures are dependent on a knowledge of the anatomy of the angle of the mandible, including the position of the inferior alveolar neuro-vascular bundle. Furthermore, cortical bone

plate thickness varies in the retromolar area of the mandible, which is important when applying mono-cortical rigid internal plate fixation.

4.1.1 THE NEURO-VASCULAR BUNDLE

Data from anatomical studies indicate that the minimal distance from the inferior aspect of the inferior alveolar canal to the inferior border of the mandible, is approximately 5,0mm (n=4,9). The mean distance at the second molar has been found to be 8,3mm and 8,9mm for the third molar region.⁴

If cortical penetration (cutting) is performed just medially to the external oblique ridge, the vertical distance between the most superior aspect of the canal and the cortex will be 6,9mm in the second molar, 10,9mm in the third molar, and 13,9mm in the most anterior symphysis region of the ramus.⁴

4.1.2 CORTICAL PLATE THICKNESS IN RELATION TO RIGID FIXATION IN THE MANDIBULAR ANGLE

The buccal cortical plate is thicker at the external oblique ridge (mean: 3,0 to 3,5mm) than at 5mm above the inferior border (mean: 2.2 to 2.5mm) by 0,9 to 1,1mm.⁴

4.2 TRANS-BUCCAL/PER-CUTANEOUS SURGICAL APPROACH

A distinct disadvantage of plating in the mandible angle is related to the plate placement on the buccal lateral aspect. This requires a trans-buccal approach (an approach through the cheek, skin, muscle and periosteum) with the use of a trocar in order to be able to place the screws at right angles (90°) to the plates,⁵ as illustrated in Fig. 1.

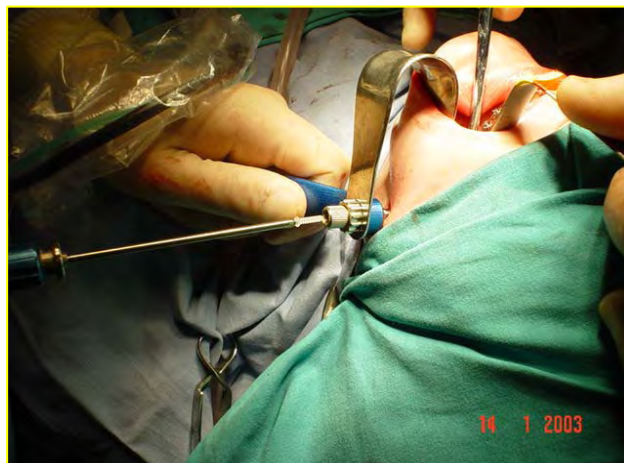

FIGURE 1. Illustration of trans-buccal technique

This in turn results in higher operating cost due to time spent and scarring of the facial skin. This has been estimated to add an additional operating time of 21 minutes (SD 11, median 17,5).⁶

Trans-buccal trocar screw placement is required for plates placed buccally or inferior to the external oblique ridge.⁷ Many studies have shown the possibility of a number of complications.⁸ Per-cutaneous instrumentation can cause a haematoma, false aneurysms, nerve fall-out, longer operating time, skin scarring, and furthermore, complicated extended operation time in removal of such plating systems.

Two-plate fixation is more time-consuming and the trans-buccal use of a trocar, which contributes to extended operation time, resulting in longer exposure time of bone to a higher bacterial contamination. Loss of a screw during the surgical procedure, introduced through the trocar, results again in extended operating time as it might have to be retrieved from a tissue plane.

Per-cutaneous instrumentation is also essential when applying the mono-cortical strut plate system (used to provide increased strength) at the angle of the mandible.⁹

The angle of the mandible, where the majority of fractures are located, demonstrates inferior narrowing and the location of a third molar, as an impaction or un-erupted tooth, has a major impact on stabilization of a fracture. Due to the biomechanics of the mandible, these fractures are associated with the highest incidence of post-surgical complications.¹⁰

4.3 BIOMECHANICAL CONSIDERATIONS

In the past three decades, a variety of studies has contributed to the conceptualization of the biomechanical principles dictating mandibular behaviour during normal function. The two-dimensional models demonstrate tension at the level of the dentition and compression at the lower border of the mandible whereas the 3-dimensional approach includes forces of the musculature on the balancing side during mastication.^{11,12} Based on these principles, different methods of plate fixation have evolved to solve the problem of displaced fracture segments.

Currently, controversy continues unabated about the use of one or two mini-plates in mono-cortical plating for the purpose of providing adequate support and stability to facilitate effective immediate function.

In the conventional plating systems, stability is derived from tightening the screw perpendicular to the mini-plate and adjacent bone. Anatomical constraints limit intra-oral access for bi-planar placement of the plate located on the lateral surface of the external oblique ridge. The difficult anatomical access necessitates compensation by drilling and screw application at an angle other than the required right angle. This practice results in an inevitable acute placement angle of screw, screwdriver and screw to bone interface.

Mechanical engineering theory states that, for identical placement loads, screws inserted perpendicular to the engagement surface,

should provide twenty percent more resistance to displacement than other placement angulations.¹³ However, viewed from a bio-mechanical perspective, bi-cortical engaging screws inserted at an angle smaller than 90° have a longer surface area of interfacial cortical bone contact and this factor may eliminate the theoretical disadvantage of screw placement at 60° angulation to the bone surface.¹⁴ If this principle is applicable, it can be assumed that the 60° and the 90° configurations should exhibit similar biomechanical characteristics.

5. STATEMENT OF THE PROBLEM

The preceding résumé of the literature indicates an awareness of the factors that influence the prognosis of mandibular fracture fixation. In general, these factors are related to three areas:

- (i) Anatomical and surgical constraints
- (ii) Analytical investigations of the biomechanical behaviour of the mandible
- (iii) Biomechanical design and location of the fixation system

While the first area has enjoyed extensive investigation, the second area which has to do with prediction of functional stability, is subject to complicated analytical methodology. The third area, which concerns the design and location of the fixation systems, is extensively but inconclusively reviewed. Very little attention has been given to:

- (i) Development of less complicated methods for delineating the biomechanical behaviour of the mandible for functional stability determination of fracture fixation.
- (ii) Addressing the problem of anatomical positioning of the plating system to ensure a minimal invasive surgical technique and cost effective operating time.
- (iii) The relationship between biomechanical stability and the screw placement angle in mono-cortical fixation.

Since the prognosis of mandibular angle fractures, osteosynthesis segments are dependent on post-operative stability of the displaced segments. There is a need for detailed consideration of the fixation characteristics of acute vector angled screw mini-plate designs.

6. EXPERIMENTAL PROCEDURES

The materials and methods used during this study will be documented in sections which are broadly co-incident with the lines of the investigation followed.

6.1 COMPILATION OF MANDIBLE SAMPLES

A total of 60 polyurethane synthetic mandible replicas (Synbone, Landquart, Switerland) will be used in this study. These synthetic

replica mandibles simulate the human mandible by demonstrating a rigid outer cortex and softer medulla component.

This uniformity allows for more reliable comparison of fixation techniques by eliminating the variability normally seen in cadaveric and sheep mandibles. The specimens will be sectioned in the midline to produce 120 hemi-mandibles for evaluation. These samples will be divided into four categories with 30 specimens in each category. The different fixation categories consist of:

- Mini-plate with 90° screw placement angle
- Mini-plate with 75° screw placement angle
- Mini-plate with 60° screw placement angle
- Mini-plate with 45° screw placement angle

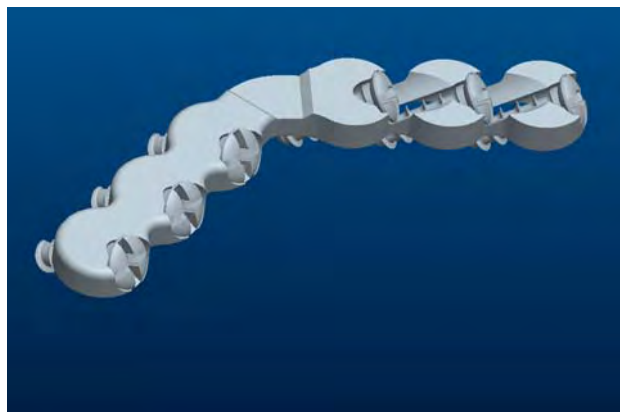

FIGURE 2. Illustration of a design for angled screw placement

These categories will be further subdivided into two different groups, each comprising 15 samples for the 3-dimensional fixation stability evaluation. The modes of loading to determine biomechanical stability, in the developed test jig for each group, are the following:

- Tension and compression evaluation
- Torque evaluation

6.2 FABRICATION OF POSITIONING TEMPLATES

An intact hemi-mandible will be used for the fabrication of the three polymethylmethacrylate (PMMA) localization templates required for standardised and chronological preparation of the test samples and positioning of these samples in the mechanical testing device as follows:

- Rigid fixation template

The purpose of this template is for rigid fixation of the proximal segment of the test module to the vertical fixation plate of the test jig.

Use of the prefabricated PMMA template will standardise and correlate the required receptacle holes through the coronoid/ramus region and the existing receptacle holes in the

vertical fixation plate. Furthermore, the location of these receptacle holes in the mandible, will align the distal section of the test module to the free-rotating crib located on the horizontal rotational axis of the load application wheel to be employed for torque evaluation.

- Mini-plate positioning template

The template for standardised mini-plate localisation on the ventral aspect of the external oblique ridge, is designed to accommodate two different plate positions in close proximity to one another. The upper position will be employed for tension/compression evaluation whereas torque will be derived from the inferiorly located structure. This approach is primarily a cost saving exercise which is unlikely to compromise biomechanical principles. The template will feature profile perforations imprinted to accommodate actual placement of the mini-plates for precise localization and screw access hole preparation. In addition, the screw access holes on the various mini-plates will have drill guides for accurate angular preparation and predetermined depth penetration for the fixation screws.

- Segmentation template

The mini-plate position template will be modified to incorporate a guide for the introduction of standardized horizontally unfavourable osteotomies at the angle of the replica hemi-mandibles. The sectioning procedure will be undertaken simultaneously with the preparative procedures adopted for mini-plate localisation. The template will feature two corresponding and linearly aligned bi-cortical engaging guiding trenches, ± 5 mm in length located on the upper and lower aspects of the template allowing orientation slots to be cut into the surface of the synthetic mandibles. Standardised sectioning will be obtained by linear connection of the prepared slots after removal of the template and employing a reciprocating saw with a blade width of 0,9mm for segmentation.

6.3 MINI-PLATE FIXATION PROCEDURES

The osteomised segments will be connected (fixated) by means of the experimentally designed and prefabricated titanium six-hole curved mono-cortical fixation plates identical in profile (Stryker Leibinger, Freiburg, Germany) as illustrated in (Figs. 2 and 3).

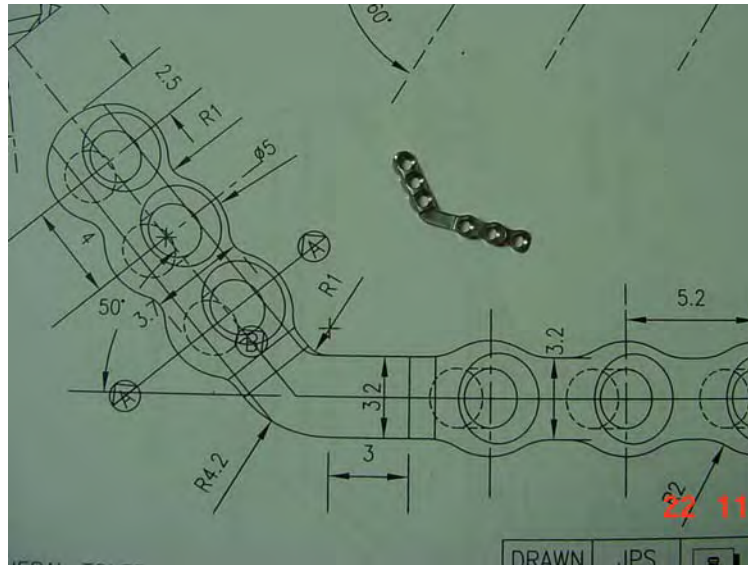

FIGURE 3. A designed curved mini-plate illustrating different screw angle placements

Identically pitched self-tapping screws, 7mm in length and 2mm in diameter, will be employed for fixation. The different mini-plates will be positioned to correspond with the previously prepared screw holes on the segments and each screw tightened to predetermined standardised interfacial pre-loads using the calibrated torque screwdriver (Fig. 4).



FIGURE 4. Calibrated torque screwdriver

The completion of preparative procedures on the hemi-mandibles necessitates accurate localisation and fixation of each individual test specimen in the testing device for 3-dimensional flexural load-displacement evaluation.

6.4 BIOMECHANICAL INVESTIGATION

The 3-dimensional stability testing device that will be used for the stability potential evaluation of the fixated test module, involves the incorporation of the test jig, as shown in Fig. 5, within the Z010 Zwick testing machine (Zwick, Ulm, Germany).

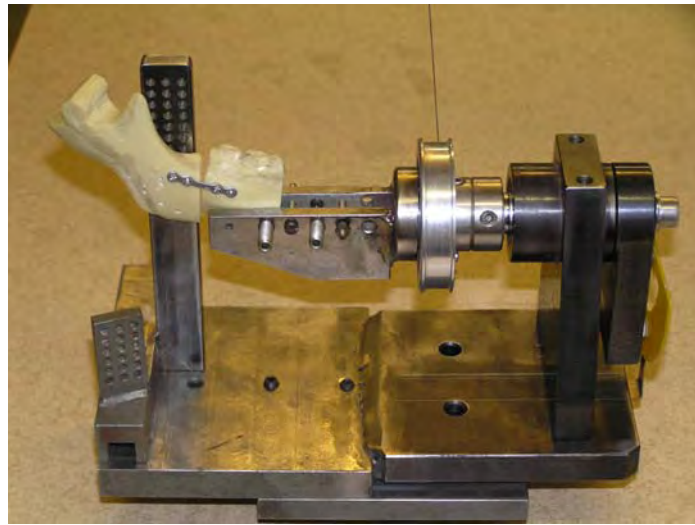

FIGURE 5. Photograph of 3-dimensional experimental jig with fixated test module

- Tension/Compression evaluation

The jig basically consists of two testing platforms. The one platform features a fixed vertical mounting plate for stabilising the experimental model in order to perform load-deflection by application of specific load at a standardised predetermined distance from the osteotomy site. The vertical load induced via the loadpin as illustrated in Fig. 6 in the Zwick machine, facilitates determination of the tensile and compressive (cantilever) displacement that occurs within the fixated test samples. All measuring will be performed by the same operator.



FIGURE 6. Photograph of loadpin in Zwick machine

Physical displacement of the segments (gapping) will be obtained from the load-displacement data. Gaps between the displaced segments will be measured using a filler taper gauge at the inferior and superior margins. Vertical displacement will be measured at the inferior boarder. The relationships between gap widths and incremental compression/tension values will be documented to produce a graphic linear regression model.

- Torque Evaluation

The second platform of the test jig consists of a rotating model holding device. This device features a round disc 4cm in diameter located on a horizontal rotational axis with a wound steel cable having a tensile breaking force of 500 Newton. One end of the cable is fixed to the disc and the other end is attachable to the loadpin of the Zwick machine. Specific load application by the Zwick machine on the wound cable, induces shear deformation on the experimental model. Torsional loads are obtained by value substitution in the following formula:¹⁵

$$D = F \times r$$

where $D = \text{Torque (Nm)}$

$F = \text{Tensile Force (N)}$

and $r = \text{radius of disc (mm)}$

The experimental validity of this formula is dependent on a constant radius. This is achieved and controlled by maintaining a constant cable to wheel angle during application and relaxing of the load.

In addition, a scale of degrees is secured to the rotating axis of the platform to record the degrees of rotation in response to tensile loading of the model as shown in Fig. 7.

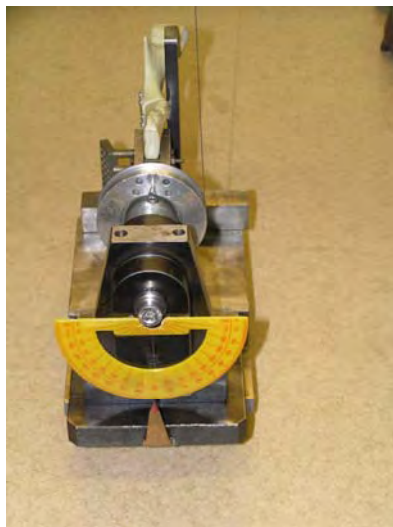

FIGURE 7. Device used for measuring the degrees of rotation at specific torque applications

During loading, the physical displacement (segment gapping) in the horizontal plane, (bucco-lingual, displacement), will be linearly measured at the superior boarder, of the test module using the mentioned filler taper gauge, as illustrated in Fig. 8. The relationships between gap widths and incremental torque values will be documented and used to produce a graphic linear regression model.¹⁶

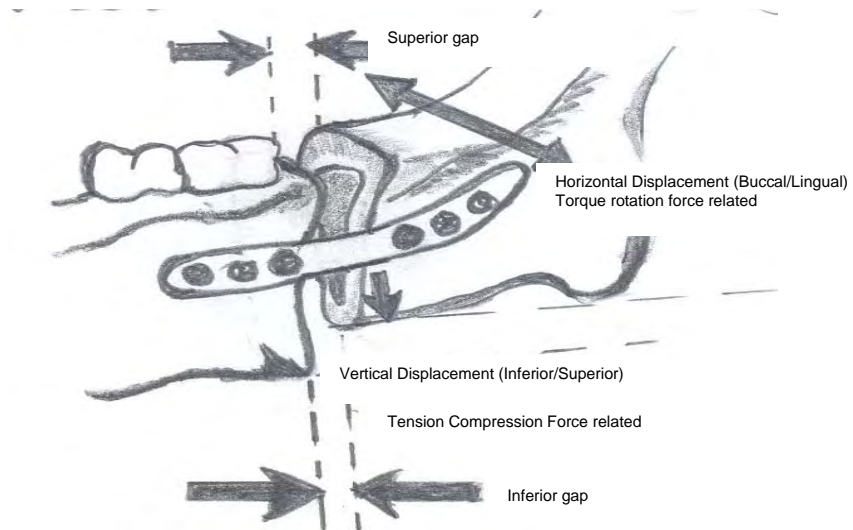

FIGURE 8. Illustration of linear displacement measurement methods utilised

- Load displacement evaluation

All the load displacement tests will be conducted in the Zwick machine. The experimental jig with the mounted test models will be incorporated within the testing machine by means of adaptor plates. The resistance to the applied tensile, compressive and shear loads will be regulated. A progressive load up to a maximum of 35 Newton will be applied to simulate clinical conditions. Loading in the system will be 10 times less than in normal human clinical conditions. This is due to discrepancies between the elastic modulus of living bone and artificial polyurethane. Therefore 1,0 Newton in the test machine is equal to 10 Newtons clinically.¹⁶ These loading parameters are based on studies of bite force in post operative patients. The assumption made is that meaningful information regarding mechanical behaviour should be obtained within the 0-100 Newton range for incisal edge loading and 0-200 Newtons range for contra lateral loading.¹⁶

The velocity of the cross-head travel of cross head travel will be regulated. Furthermore, a tension-compression load cell 50N type 8301 will be calibrated and used throughout this investigation (Fig. 4). Before each test, the experimental jig

containing the test model will be secured to the lower base of the Zwick machine and calibrated to obtain a zero deflection value on the chart recorder. The load displacement characteristics will be recorded on the computerised chart recorder. From the known deflection values on the chart recorder, it will be possible to derive the stability values of each fixation design relative to the magnitude of the applied load.

Before experimental stability determination of the prepared test models, five unprepared intact hemi-mandibles will be used as controls to define the limitations of the substrate (synthetic mandible replicas) and testing jig.

Incremental load displacement testing with zero, five, fifteen, twenty five and thirty five Newton will be conducted to determine the stability of fixated test samples for two modes of load applications, tested as tension/compression and torsion.

Furthermore, the amount of physical displacement of segments (gapping) that occurs during the two modes of loading, will be obtained.

7. RESULTS

The results obtained during the course of the investigation will follow an outline similar to that used in presenting the load displacement evaluation of the experimental procedures. A summary of computed results and the statistical analysis will be presented in tabulated and graphic format.

The tension/compression and torque load displacement results obtained from these evaluations will be separately tabulated as a load/displacement series of individual group values for each of the four different fixation categories. The average values of each categories will each be depicted individually and comparatively in graphic illustrations.

The mean and standard deviations will be derived from the abovementioned data tables and compared for statistical significance within the fixation categories using a one-way analysis of variance ($P < 0.05$) and tabulated.

7.1 TENSION/COMPRESSION DISPLACEMENT RESULTS

The physical linear superior displacement values measured in millimetres, will be derived from the load/displacement data and tabulated for each fixation category in the test series.

The mean and standard deviations will be derived from the tabulated results, compared for statistical significance within the fixation categories using one-way ANOVA ($p < 0.05$) and tabulated.

The dependence of gap width on cantilever load will be graphically demonstrated by means of a simple linear regression model for comparative evaluation of the different fixation categories.

7.2 TORSIONAL DISPLACEMENT RESULTS

Similarly, the physically linear lateral gap displacement expressed in degrees of rotation in response to the applied torsional loads, will be tabulated.

The mean and standard deviations, obtained from the tabulated results, will be compared for statistical significance within the fixation categories using one-way ANOVA ($p < 0.05$).

The relationship between gap width and torsional loading will be graphically illustrated using first-order polynomial best-fit curves for comparative evaluation of the different fixation categories.

7.3 COMPARATIVE RESULTS

The clinical relevance relating to trans-buccal screw application and its preferred more cost effective alternative, the intra-oral approach, as it applies to screw angle placement, will have been researched.

8. OUTCOMES

8.1 BACKGROUND

8.2 THE PILOT/FEASIBILITY STUDY

Mono-cortical management of mandibular fractures – A new plating system (MIMAS).¹⁷

Presentations:

Topic: Minimal – invasive – Mono-cortical – angle -system – Load sharing and load bearing forces : IADR Congress Pretoria, September 2004

- Presented:
1. Jacobs F.J., Botha S.J.¹⁷ (as abstract)
Facial Trauma Congress
University of the Witwatersrand
February 2003
 2. Jacobs F.J., Botha S.J.¹⁷ (as abstract)
16th International Conference on Oral and Maxillofacial Surgery
Athens, Greece
May, 2003¹⁷

Innovative developments

Design and manufacture of:

- Biomechanical test jig
- 60° angulated plates

8.3 ENVISAGED OUTCOMES

It is envisaged that the results of this study should lead to:

8.4 PhD THESIS

8.5 PRESENTATION

Angled intra-oral plating system (AIOPS)17th International Conference on Oral & Maxillofacial Surgery, Vienna, Austria September 2005

8.6 PUBLICATION

To be publish and in relevant Scientific Journals

9.	EXPERIMENTAL MATERIALS	ZA Rand	
	<ul style="list-style-type: none"> • Synthetic mandibles • Manufacturing of jig and templates 		15,000 5,000
9.1	EXPERIMENTAL PROCEDURES		
	<ul style="list-style-type: none"> • Human Resources Laboratory hours (120 Hrs) Instrumentation and Labour @ R100 per hour * Software programme * Printing/Duplication of test results * Statistical analysis 		12,000 500 500 1,500
9.2	PRESENTATIONS AND PUBLICATIONS		
	<ul style="list-style-type: none"> • Presentations • Publications * Thesis * Articles 		500 10,000 1,000
	Total	ZA-Rand	46,000

10. Finance. Stryker-Leibinger Research Fund
Development fund in Department of MFOSurg,
University of Pretoria

11. ETHICAL CONSIDERATION

This in vitro study is not ethical- implicated due to Stryker-Leibinger support.

12. TIME SCHEDULE

Experimental procedure and complication of results should require approximately 16 weeks to conclude.

For preparation and finalisation of thesis, a period of ± 2 years is envisaged.

13. REFERENCES

1. Roberts, W.R. The case for mandibular plating. *Brit J Oral Surg* 1964; 1: 200-4.
2. Worthington, P., Champy M. Monocortical miniplate osteosynthesis. *Otolaryngo Clin N Am J* 1987; 20: 607-20.
3. Tillmann B., Harle F., Schleicher A. Biomechanik des Unterkiefers. *Dtsch Zahnarzl Zeitschr* 1983; 38: 285-93.
4. Uckan S., Schwimmer A., Kumner F., Greenberg A.M. Effect of angle of the screw on the stability of the mandibular sagittal split ramus osteotomy : A study in sheep mandibles. *Br J Oral Maxillo-Fac Surg* 2001; 39: 266-68.
5. Borstlap, W.A., Stoelinga, P.J.W.A., Hoppenreijns, T.J.M., Van't Hof, M.A. Orthognatic surgery stabilization of sagittal split advancement osteotomies with mini-plates : A prospective, multi-center study with two-year follow-up, Part 1. Clinical parameters. *J Oral Maxillo-Fac Surg* 2004; 62: 892-94.
6. Kroon, F.H.M., Mathison, M., Cordey, J.R., et al. The use of union-plates in mandibular fractures. An in-vitro study. *J Craniomaxillofac Surg* 1991; 19: 235-38.
7. Levy, F.E., Smith, R.W., Odland, R., Marentette, L. Mono-cortical mini- plate fixation of mandibular angle fractures. *Arch Otolaryngol Head Neck Surg* 1991; 117: 149-54.
8. Zachariades, N., Skoura, C., Mezitis, P., Marouan, S. Pseudo-aneurysm after routine trans-buccal approach for bone screw placement. *J Oral Maxillofac Surg* 2000; 58: 671-73.
9. Guimond, C., Johnson, J.V., Marhena, J. Fixation of mandibular angle fractures with a 2mm 3-dimensional curved angle strut plate. *J Oral Maxillo-Fac Surg* 2005; 63: 209-14.
10. Ellis, E., Walker, L Treatment of mandibular fractures using two non-compression mini-plates. *Oral Maxillo-Fac Surg* 1994; 52:1032-6.
11. Pruijm, G.J., de Jongh, H.J., ten Bosch, J.J. Forces acting on the mandible during bilateral static bite at different bite force levels. *J Biomech* 1980; 13: 755-60.
12. van Eijden, T.M. Three-dimensional analyses of human force magnitude and moment. *Arch Oral Biol* 1991; 36: 535-9.
13. Perren, S.M., Cordey, J., Baumgart, F., Rahn, B.A., Schatzher, J. Technical and biomechanical aspects of screws used for bone surgery. *Int J Orthop Tr* 1991; 2: 31-48.
14. Smith, B.R. The anatomy of the mandible as it relates to the medial ramus osteotomy and rigid fixation of the sagittal split osteotomy (Thesis). Houston (TX): Baylor Univ., 1988.



15. Feller, K-U., Richter, G., Schmeider, M., Eckelt, U. Combination of microplate and mini-plate for osteosynthesis of mandibular fractures: An experimental study. *Int Oral Maxillo-Fac Surg* 2002; 31: 78-83.
16. Wittenberg, D.P., Mukherjee, B.R., Smith, R., Kruse, N. Biomechanical evaluation of new fixation devices for mandibular angle fractures. *Int J Oral Maxillo-Fac Surg* 1997; 26: 78-73.
17. Jacobs, F.J., Botha, S.J. The minimal invasive mono-cortical angle system, MIMAS. *Int J Oral Maxillo-Fac Surg* 2003; 32: S1-S2.



UNIVERSITEIT VAN PRETORIA
UNIVERSITY OF PRETORIA
YUNIBESITHI YA PRETORIA

Addendum 3: Biomechanical In Vitro Test

BIOMECHANICAL NOTE (internal use only)

Primary stability of angular fracture osteosyntheses

Introduction

Based on a customer suggestion, a new product was designed for fractures of the mandible angular region. This new plate helps avoiding trans-buccal access for screw fixation when applying osteosynthesis near the linea obliqua. In order to simplify the screw handling via oral access and assure cortical screw retention, the counter sink axes are non-orthogonal but inclined to the plate main plane.

A biomechanical study was used to simulate both the adaption to indication and physiological load.

Method

For biomechanical experiments, plastic mandibles were used in order to extinguish the influence of inter-individual variations of cadaveric specimens. Standardized fractures were set by perforation. The fractures were fixed monocortically by three different implants (Fig. 1, Fig. 2, Fig. 3): **Standard Würzburg 6hole plate** (Stryker 01-08206), **Universal Fracture plate** (Stryker 55-15526), and the forthcoming **MANDIBLE ANGLED FRACTURE plate** (Stryker 55-XXXXX).



Fig. 1: Application of Standard Würzburg plate according to Campy

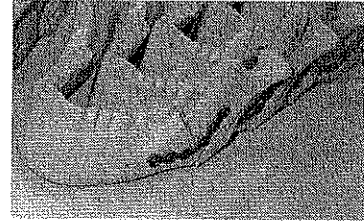

Fig. 2: Lateral application of Universal Fracture plate

K-Wires were attached in order to measure their load dependent angle changes (Fig. 3). The relative displacement of anterior and posterior fragments: **Bending [°]** (sagittal plane) and **Torsion [°]** (fracture plane).

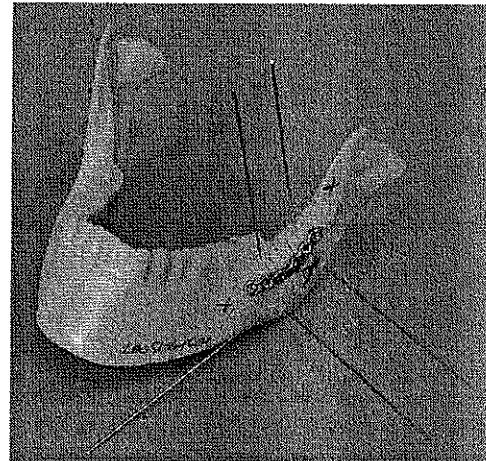

Fig. 3: Plastic mandible with forthcoming plate and K-wires

The physiological load (Fig. 4) was realized using a test rig (modified after [1]). Functional loads as dental - incisally, molar contralaterally and ipsilaterally - and muscular (M. masseter) were applied. Beginning with a preload of 20N, 5 steps of 50N (0, 50, .. 250) were examined.

BIOMECHANICAL NOTE (internal use only)

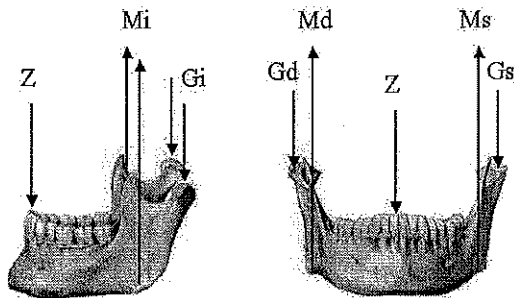

Fig. 4: Functional statical loading of the mandible: dental (Z), muscular (M) and TMJ (G)

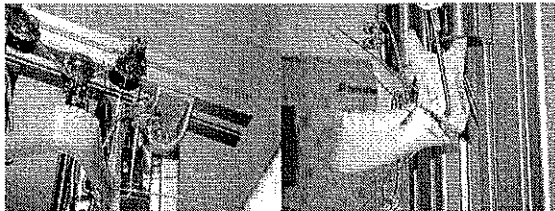

Fig. 5: Simulation of statical load situations, frontal and lateral view, 150N ipsilateral load

Results

According to Shetty et al. [2], the factor of instability was calculated: $I=(B^2+T^2)^{0.5}$ (the 3rd degree of freedom - lateral-buccal displacement - was negligible).

Depending of the location of the osteosynthesis, significant differences were observed: SW6 is attached superior to the linea obliqua and is stiffer than UF and MAF when loaded contralaterally and incisally. UF and MAF are attached laterally

References

1. Kroon, F.H.M.; Mathisson, M.; Cordey, J.R.; Rahn, B.A.: The use of miniplates in mandibular fractures. J. Cranio-Fac. Surg. 19, 199-204, 1991
2. Shetty, V.; McBrearty, D.; Fournay, M.; Caputo, A.A.: Fracture line stability as a function of the internal fixation system: an in vitro comparison using a mandibular angle fracture model. J. Oral. Maxillofac. Surg. 53, 791-801, 1995

to the mandible model and respond to all load situations, but less ipsilaterally than incisally or contralaterally.

Summing up all 3 load situations, the average factor of instability is defined by $I_g=(I_n+I_o+I_p)/3$ and its standard deviation I_x , which is considered the sensitivity balance of the 3 load situations.

Table 1: key data for 250N load

		SW6	UF	MAF
I_o	contralat. load	0.75°	4.14°	4.94°
I_n	incisally load	1.13°	3.46°	4.85°
I_p	ispilat. load	56.28°	2.27°	3.72°
I_g	average Instability	19.39° ~ 100%	3.29° ~ 17%	4.5° ~ 23%
I_x	std. dev. Instability	31.95°	0.94°	0.69°

Table 1 shows that the Standard Würzburg plate is not an option for the ipsilateral load situation. The average stability of the Universal Fracture plate is 37% higher but 13% less balanced than that of the Mandible Angled Fracture Plate.

Considering the different surgical procedure, the Mandible Angled Fracture plate has an advantage by avoiding the trans-buccal access.



UNIVERSITEIT VAN PRETORIA
UNIVERSITY OF PRETORIA
YUNIBESITHI YA PRETORIA

Addendum 4: The Mandibulator

THE MANDIBULATOR

by Heinrich Schieferstein, © 1998-2004

Introduction

The successful treatment of maxillofacial fractures requires the exact anatomical reposition of the fragments. The fixation has to stand functional loads at a minimum restraint of the function.

Currently, plates and screw of titanium are used. The history of these implants started at the end of the 19th century empirically. By now, there are two different approaches: while some surgeons propagate massive and rigid plates, other believe in the miniaturisation of plates for internal reposition.

The further development of osteosyntheses is based in simple biomechanical experiments which are geared towards clinical experiences. For the validation and optimization of the state-of-the-art concepts, more expense of theoretical and experimental investigation is required. Recent biomechanical experiments need fundamental revisions and consequent maturation.

The masticatory system carries out two main tasks: nutrition and communication. Since chewing and speaking are multi-factorial processes, their theoretical and experimental simulation require knowledge of Physiology and Biomechanics. Most of the recent models are static ones.

Total joint replacement in the lower extremity is routine for about a half century, therefore the knowledge of the in vivo loads is highly sophisticated. Test standards for fatigue and wear are given. The fields of cranio-maxillofacial surgery still miss adequate data for implant lay out and tests.

The aim of this study was the development for a tool which may be used for the experimental validation of mathematical models and the definition of characteristic load situations. Up-to-date product design is increasingly ruled by simulations. Before introducing new products to the market, their functional ability has to be proven experimentally.

Status Quo

During the last five to ten decades, many theoretical and experimental approaches have been published while the development of surgical implants is done secretly. The origin of the data used for implant layout or mathematical simulation differ considerably as far as they are published.

Experiments can be distinguished in following groups: in vivo, in vitro. While the in vivo investigations are based on animals, the in vitro experiments operate with plastic models or cadaveric materials. It suggests itself that all these attempts vary considerably. The influence of the geometry and topology of different materials used casts doubt on the comparability of resulting stress and strain which finally rule the mechanical meaning.

Mathematical models of the human masticatory system assume amount and direction of the muscular forces. Some models use measured data regarding dental forces or joint geometry. All mathematical models are based on the static equilibrium of the involved forces; the models are two or three dimensional; the function of the M. pterygoideus medialis is discussed inconsistently.

Experiments are non-dynamic and use a variety of materials: human plastic or cadaveric mandibles, porcine cadaveric mandibles, bovine ribs. The loading situation depends on the topic, whether a sagittal split, a premolar or incisal fracture. Some experiments deal with the deformation of the complete bone, usually strain gauges are applied.

A new experimental platform is required for realistic loading of mandible with or without implants. Human mandibles or plastic models have to be applied in order to reproduce the geometry and topology situation faithfully. Primary stability of the compound of bone and implant needs static experiments while fatigue tests need cyclic/dynamic performance.

Mathematical models or diagnostic data provides test parameters. Depending on the problem, physiological and pathological situations will be adjusted simplified or complex.

Mandibulator

The demands on the experimental bench in brief: versatility, reliability, robustness, easy handling and extension.

Besides static experiments for the validation of mathematical models, dynamic/cyclic operation for implants are required.

The set-up needs an adaptation to various problems regarding joint or dental loads without much expense. The measurement of mandibular deformation or fragment deviation needs

high quality level on one hand, contact free and feasible on the other hand. Handling, change and programming should be accessible for non-professional users.

Hydraulic drives were chosen for load application. The range includes 0 to 1.000 N. Eleven of the sixteen drives can be controlled in the range of 0 to 100 mm alternatively. The force diversion is realised by stretch free Nylon ropes and frictionless blocks.

As load sensors, each hydraulic cylinder has a force sensor; the artificial temporomandibular joints have three-component piezo-electric force sensor. A PC is used for both, experiment control and data acquisition. The programming is realised in LabVIEW™. The digital-analog-converter provides the analog output signal for the hydraulic control units as well as the acquisition of 42 parameters. All data is saved to disc for off-line analysis. The sampling rate 1 kHz, each force signal has a resolution of 12 bit (by 1.000 N or 100 mm). The number of cycles, optional comments is included in the log-file. The fragment shift or mandibular deformation is measured using a standard motion analysis system. Up to three cameras observe the mandible or fracture localisation. The video data is utilized by motion analysis software.



Mandibulator © 1998-2004: Heinrich Schieferstein



UNIVERSITEIT VAN PRETORIA
UNIVERSITY OF PRETORIA
YUNIBESITHI YA PRETORIA

Addendum 5: ISI – Plate: White Paper

Management of Mandible Angle Fractures -A different Angle to fixation- The Inclined Screw Insertion (ISI) Plate.

By Frederick J Jacobs, MChD, FCM (MFOS) SA, BChD (Hons).

Pretoria Academic Hospital, Assoc. Prof University Pretoria.

Fractures of the mandible angle is second most common only to parasymphseal fractures of the mandible and often present as an indirect fracture associated with a direct fracture in the corpus on the contra lateral side . Rigid internal fixation of fractures in the angle is challenging, even in the hands of experienced trauma surgeons and is associated with very high incidence of post-surgical complications. Superior border mono-cortical plating for single simple fractures, where sufficient retro-molar bone is available, is the preferred method of treatment. Inferior border gapping under compression loading and possible insufficient biomechanical stability during contra-lateral loading with torsion forces are unresolved issues. At best, even in ideal situations when applying screws in the proximal 2 or 3 plate-holes at the conventional 90 degree angle during superior border plating,

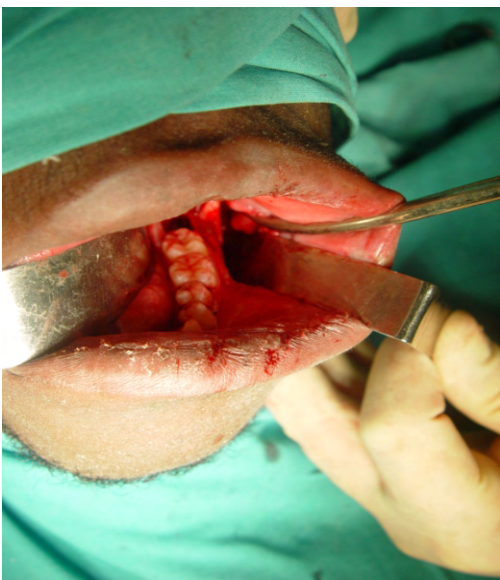

requires approach from the contra-lateral side when pilot drilling and applying screws. This in turn demands temporary removal of the inter-maxillary fixation - wiring used to establish occlusion, alignment and reduction of the fracture fragments. Tooth removal in the fracture line is required in cases with root/crown fracture or where pre-existing pathology is evident .Loss of bone contact in the retro-molar tooth-socket compromises simple superior border plating due to lack of bone buttressing of fracture segments in the superior aspect.

All rigid internal plating systems applied to the lateral aspect of the Ramus/angle according to the second Schamper ideal osteo-synthesis line (located inferior-lateral to the External Oblique ridge) demand trans-cutaneous approach in order to conventionally place screws perpendicular (90) to the plate surface. Trans-cutaneous use of an introducer can result in



complications such as haematoma, false aneurysms, nerve fall-out, skin scarring, and always results in extended operating- time .



The ISI mandible angle fracture plate is a mono-cortical 2mm. trauma plate with plate-holes angled at 60degrees for screw application from intra oral . Applied as a mono-planar , mono-plate to the caudal aspect of the External Oblique Ridge and anterior Ramus this bendable 6-hole plate specifically allows plating of the lateral aspect of the mandible via intra-oral approach saving time, is easy to

apply ,drilling at plate holes with direct vision at an angle dictated by the plate holes ensuring a stable result.

Drilling in quadrant 2 & 3 – where 2 is the angle for drilling pilot holes in the ramus section of the ISI-plate and where 3 represents the angle for drilling pilot holes in the anterior corpus section of the ISI-plate

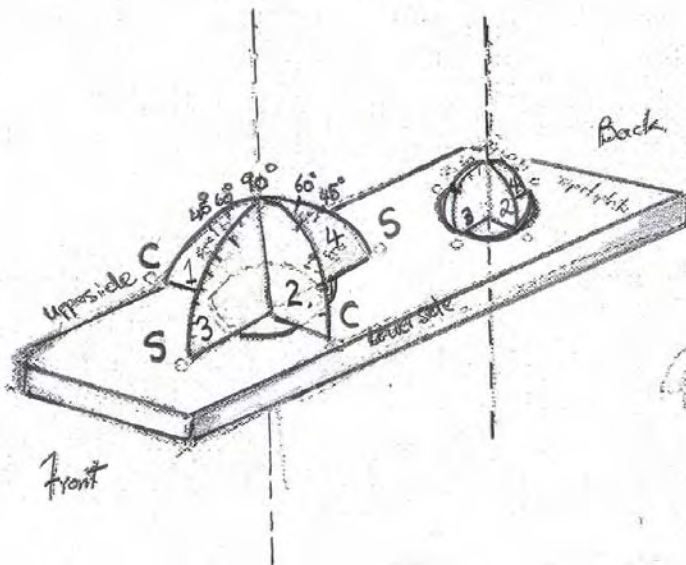

Clinical Quadrant 2

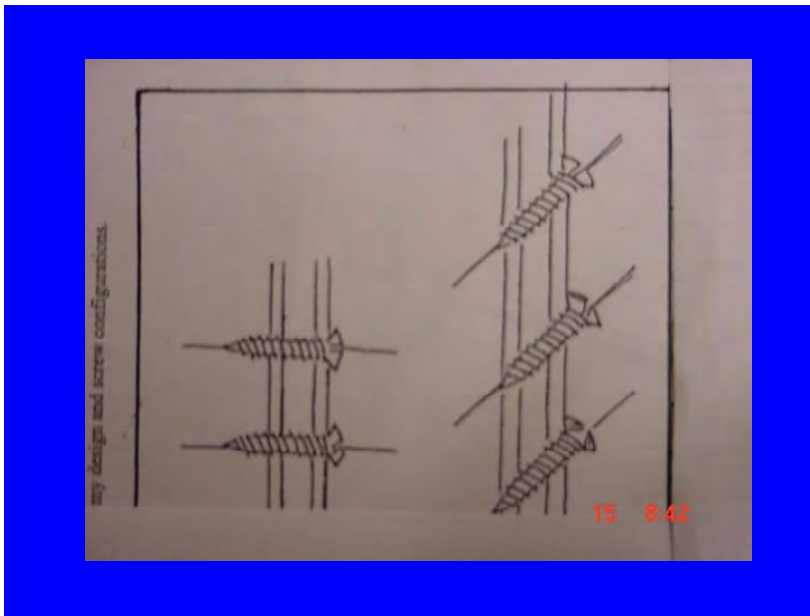

Screws inserted at 60° or 45° have a larger area of contact in the bone cortex and provide the greatest degree of resistance to movement.

A. The ISI mandible angle fracture plating system.

1. The Trauma Plate.
2. The holding/ drill-guide instrument.

1. This titanium 6-hole trauma plate -Has 60 degree slanted plate holes in an anterior to posterior direction allowing direct view into the plate-holes for pilot drilling of the bone with a 1,5mm.drill via intra-oral technique in-line of sight. The profile is 2.0mm to accommodate angled plate-holes with the ramus (cranial) 3-hole and corpus (caudal) 3-hole sections bridged by a mid section at an angle of 145 degrees,

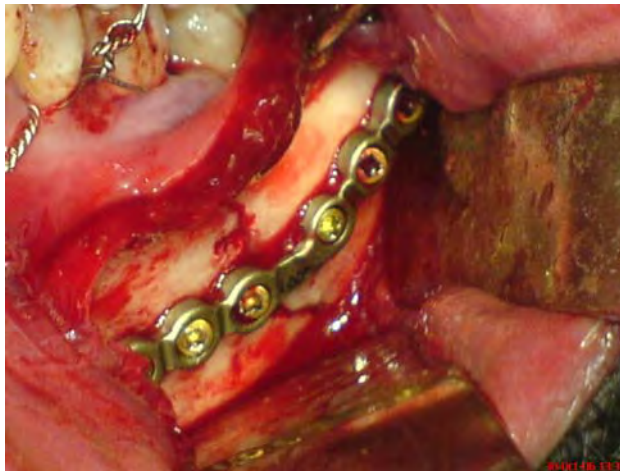

technique in-line of sight. The profile is 2.0mm to accommodate angled plate-holes with the ramus (cranial) 3-hole and corpus (caudal) 3-hole sections bridged by a mid section at an angle of 145 degrees,

An angle determined by cadaver studies of the External Oblique ridge serves as a universal angle 145 degrees, to exclude template measuring prior



to placement. This unique plate is bendable although seldom indicated and uses standard 2 mm.diameterscrews from the Stryker/Leibinger range. (fig.1.)

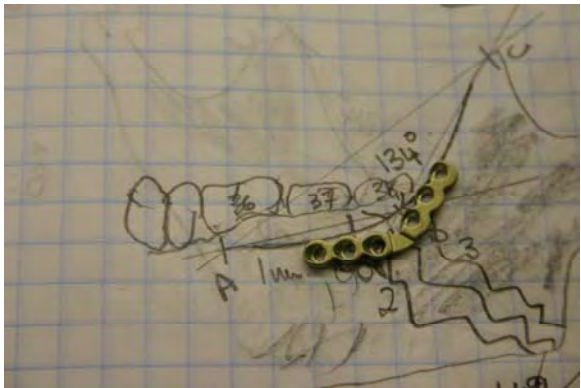

It is known from recent in vitro studies that bicortical intra oral screw placement at 60 degree angle to the saggital plane does not require extra oral trans buccal approach (S.Uckan, A. Schwimmer, F. Kummer & A. M. Greenberg, B.J. of OMF Surg. 20 March 2001).

If the same would be true for monocortical screw placement changing the screw angle design from perpendicular to 60 degrees would facilitate intra oral placement.

(A) The six-hole plate. The inclined Screw Insertion (ISI) Mandibular



angle fracture plate (MAFP)-Is a six hole trauma plate with a bridging section between the cranial 3-holes intended for application to the anterior, ramus of the mandible and the caudal 3-holes intended for application to the ventral, lateral aspect of the External Oblique ridge

(Fig.1)

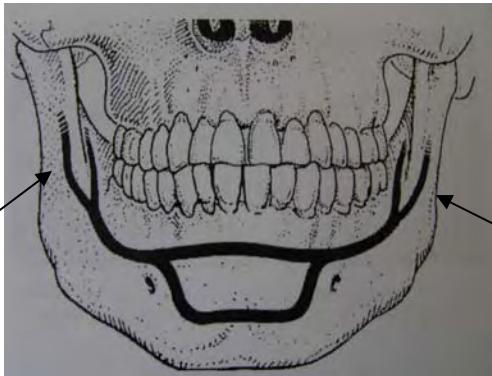
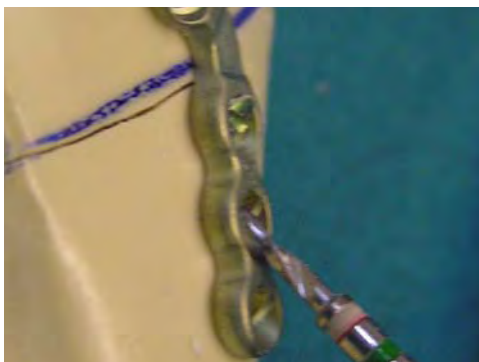

Plate fixation is performed with standard 2mm. screws according to the Schampy ideal line for osteo-synthesis in the angle of the mandible. (Fig. 2)

The trauma plates for the left and right sides are laser marked and have plate-holes at an angle of sixty degrees in the direct line of vision for pilot drilling and screw application at this angle. The plate profile is 2mm and the edge of the plate holes guide a standard pilot drill of 1,5mm diameter along the inner surface, permitting a drill at what you see, during pilot drilling and screw insertion. Pilot- drilling (Fig 3)



Why Angled screw placement and not conventional perpendicular screw fixation?

1. Superior biomechanical stability.

Greater degree of resistance to movement demonstrated in laboratory testing for both tension compression and torsion loading.



Screw application at 60 degree angle.
In vitro –poly urethane mandible-
laboratory testing.

Note the lag effect of angled screw
crossing the fracture line at 60 &45
degree insertion (arrow above).Extreme
biomechanical stability improvement
demonstrated in graph below;

Cantilever Testing – Screw angle application 45°

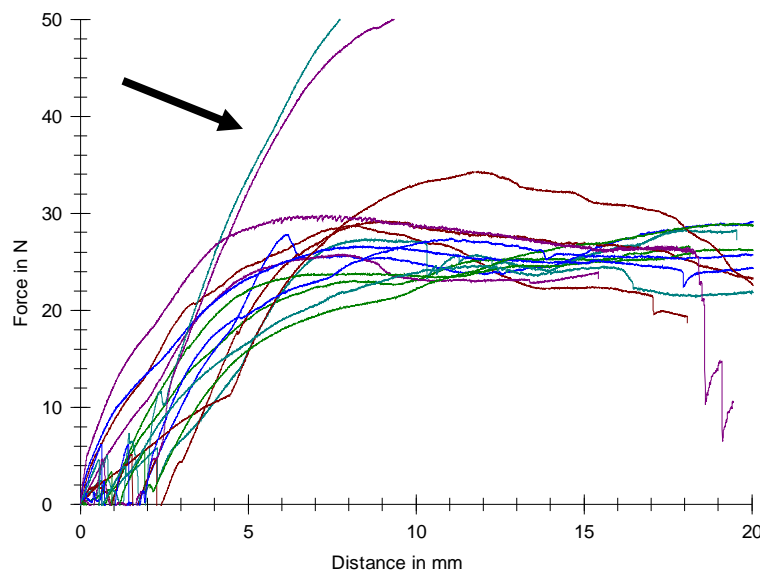

2. Intra-oral surgical technique for fixation of a trauma plate to the lateral aspect of the ramus is now possible due to angled screw- application.

All other conventional perpendicular screw placement systems used mono-planar in mono-plating of the lateral ramus, require trans-buccal instrumentation with related patient complications and longer operating time.

3. No Post-operative Inter- maxillary Fixation (IMF) required- even in partial load bearing.

4. Used in cases with additional mandible fractures to the angle presenting either as direct or indirect fractures of the symphysis and/or corpus or bilateral angle fractures.

4.1 Pre-Operative X-ray of Right Angle with left corpus fracture.



plates for left corpus.

4.2 Post operative X-Ray with ISI mandibular angle plate and two parallel

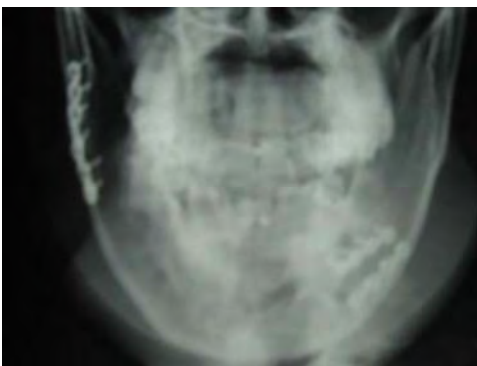

5. Indicated in cases where retro-molar region is compromised due to bone loss , infected wisdom teeth in fracture line or lack of sufficient bone surface for screw placement in the proximal fragment when placing a superior border plate.

6. Cost effective and bio-mechanically stable as a single mono-cortical trauma plate.

7. Can be used in any load sharing mandible angle fracture.

8. Simple intra-oral surgical technique –no need to temporary remove IMF in order to facilitate pilot drilling of the proximal plate holes across the occlusion from the contra lateral side.

9. Minimal plate bending required to conform to the most anterior ramus and ventral aspect of the external oblique ridge.

10. Ease of Application.

The holding device/drill guide -A instrument for gripping the plate when fitting it to the lateral aspect of the ramus prior and after bending. The holding device engages the outer profile of the first plate-hole by means of four pins –designed and positioned to enable lip clearance of the instrument when used. The holding instrument is a positioning aid to hold the plate, and may, after bending, serve as a drill-guide for drilling at 60 degrees when pilot drilling hole Nr. (2).

Surgical technique.



Using .045mm. ligature wire, eyelet wires are made, positioned according to the patients dentition and spaced to optimize the reduction stability. An incision is made intra-orally similar to the buccal soft tissue approach to the bone for a sagittal split osteotomy which includes anterior ramus stripping and limiting sub periosteal

stripping to just caudal of the external oblique ridge. A curved clamp may be applied to the anterior superior aspect of the ramus to assist in soft tissue retraction .A firm tissue retractor is used to retract the soft tissue pocket buccally- the patients head is rotated to the opposite side. After tooth removal and fracture line debridement the fracture segments are reduced and stabilized using inter maxillary fixation (IMF) and can be additionally fixated using a temporary superior border wire osteo-synthesis. The plate is bend with plate benders if required, available on the 2mm. trauma plating sets, and held by means of the special holding device clamped to the first plate-hole .The ideal plate position is the most anterior aspect of the ramus ,with the fourth plate-hole, of the cranial section of the ISI –plate just on the proximal edge of the fracture line and the anterior bar of the plate just caudally of the external Oblique ridge. The ISI mandible

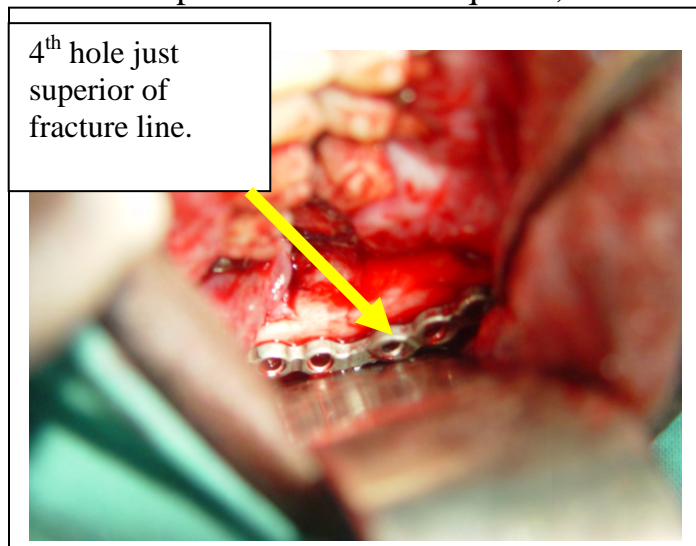

angle fracture plate is available as a universal plate and can accommodate an External Oblique angle up to 145 degrees (a template will serve as indication for larger angles to use a 160 degree plate). It is also possible to rotate the anterior bar with its three plate-holes at the connecting bar in a anticlockwise fashion for left angle plates and clockwise for right sided angle plates to fit

the distal fragment in this situation the plate would be more superiorly on the external oblique ridge.

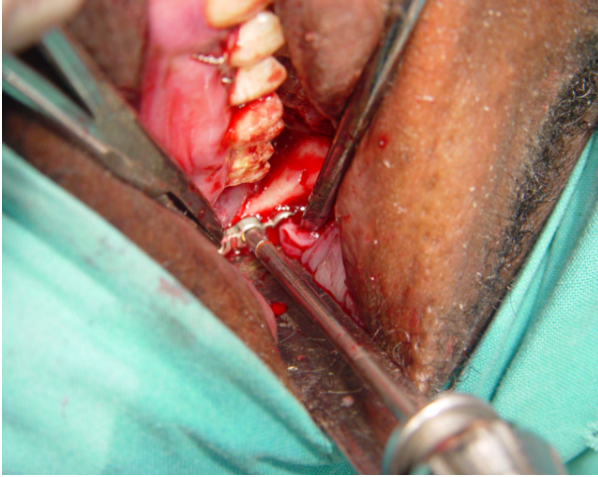

The first plate-hole to be pilot drilled is the fourth hole from the front (the first hole after the connecting bar section) drilled whilst positioning with the holding instrument gripped at the first hole –no drill guide assistance is needed when running the 1,5mm. pilot-drill along the inner surface of the plate-hole inclined at 60 degrees. A standard 2-mm. screw is inserted before holding instrument

removal , this screw is tightened after final plate rotation adjustment is done. The sequence of screw placement to follow demands that at least a screw in plate-hole position one or two is placed and tightened before placing the lag screw in plate hole Nr. 3. this is essential to stabilize the fracture segments prior to lagging screw Nr.3 –pilot drilling across the fracture line will give an impression of screw length to be placed anything from 10-15mm. length. Screw lengths of at least 7mm. are placed in other plate-holes with 7-9mm. lengths for the ramus- screws

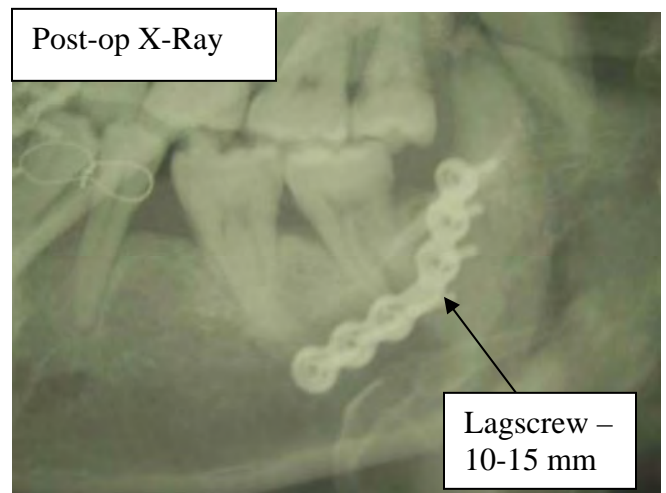
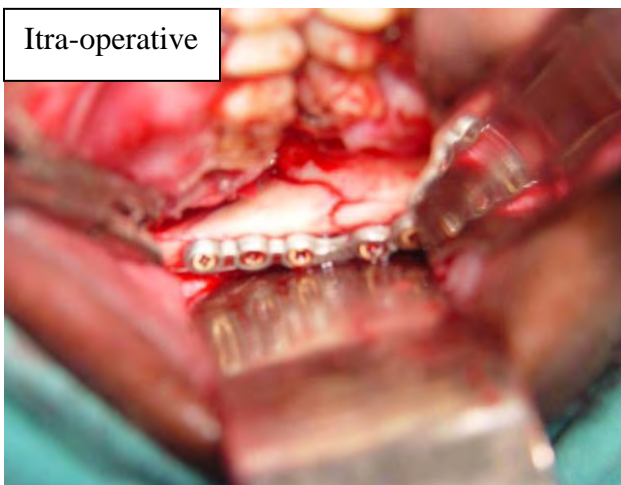



Case Reports and results:

Case 1: Bone loss – additional IMF post-op



Case 2:





Case 3:

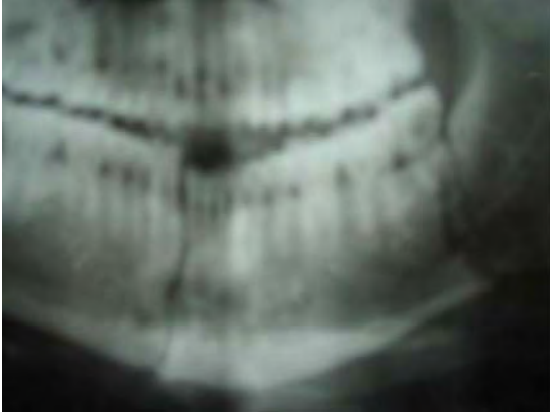

Case 4:



Biomechanical Stability Studies;

Results of a comparative study on the stability of rigid fixation, using screws of the same length and amount of torque where all variables were standardized except the angle of placement, clearly demonstrated that screw angles 60° & 45° rendered superior and significant better stability for both compression and torsion forces in a mono-cortical application.

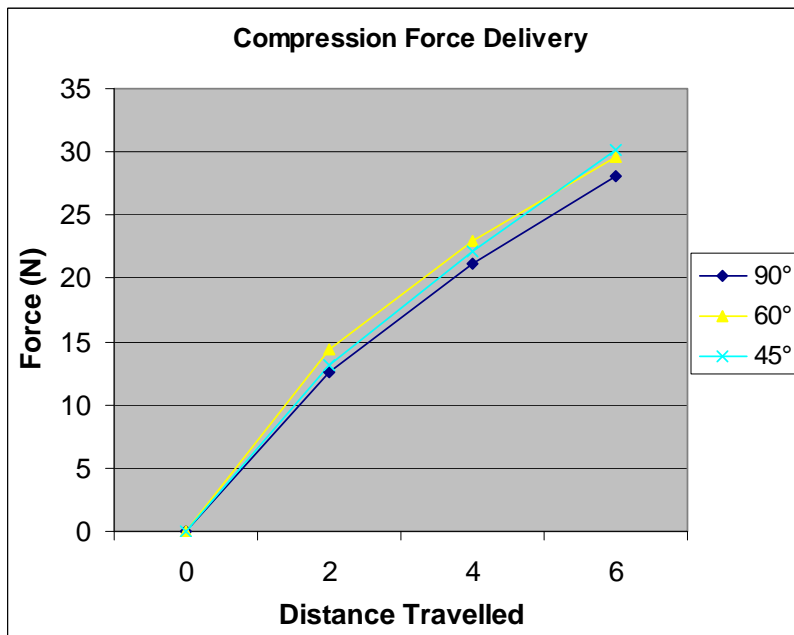
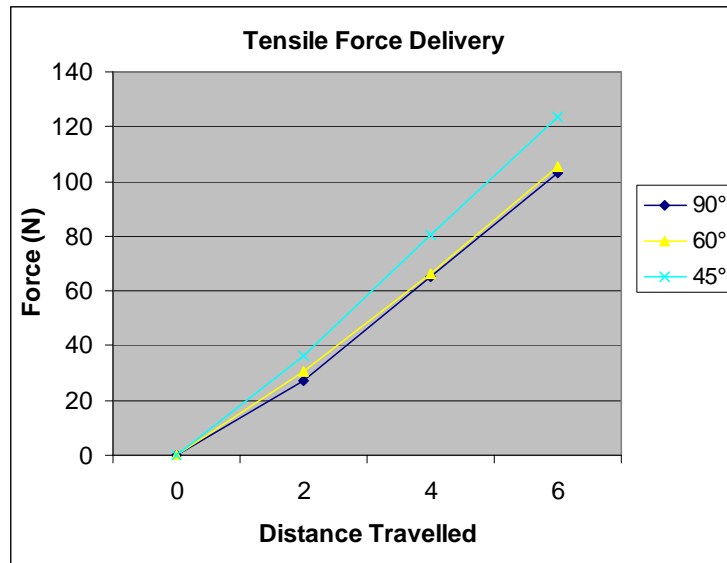



Results.

At the Pretoria Academic hospital 25 cases with mandibular angle fractures were successfully treated with the newly developed ISI mandibular angle fracture plate .Of this total , 21 were bilateral fractures and 1 a case with cortical bone loss and 3 were simple angle fractures . All cases except the bone loss case were treated without any IMF in the post operative healing period. All the fractures healed without any complications and 12 cases treated were older than 10 days post trauma when repaired.

In a retrospective analysis of 2,609 cases of mandibular fractures treated between period January 2000 and May 2004 with teeth involved by Dr. J P White , teeth were present in the fracture line in 85% of cases. Mandibular fractures occurred more in males (88%) than in females (12%).The most common sites of teeth in the fracture line were the angle fractures (64%), parasymphysis (26%),corpus (17%) and the symphysis (10%).

Conclusion.

The ISI Mandibular angle fracture plate renders a fast simple, intra oral surgical technique solution to any load sharing angle fracture of the mandibula and adds a new dimension to the Maxillofacial surgeons armamentarium for the mono-cortical management of all angle fractures, saving time and complications as no trans-cutaneous technique is employed for the lateral application of this plating system.

The angled screw application is unique and superior to conventional perpendicular screw application and results in screw lagging across the fracture line, the use of longer screw lengths with larger area of contact in dense compact bone cortex as a mono-cortical system and is a mono- plating system applied to the lateral aspect of the angle of the mandibula resulting in biomechanical stability for compression and torsion forces superior to any mono cortical system available .The surgeons scope for the effective intra-oral mono-cortical treatment of angle fractures is expanded to also include bilateral fracture situations . From patient perspective ensures no IMF in the post operative healing period , minimal post-operative complications as teeth in the fracture line can at all times be removed (even with radiographic evidence of chronic low grade infection around impacted wisdom teeth) and should the need arise for later removal of the plate the angled screws can easily be exposed and in direct line of vision, through intra-oral approach , be removed- as apposed to perpendicular screws on the lateral aspect of the ramus.



UNIVERSITEIT VAN PRETORIA
UNIVERSITY OF PRETORIA
YUNIBESITHI YA PRETORIA

Addendum 6: USA Patent Registration

PATENTANWÄLTE:
AXEL VON HELLFELD, DR. DIPL-PHYS.
JOBST WIBBELMANN, DR. DIPL-CHEM.
STEFFEN J. SCHMIDT, DIPL-ING.
ANDREAS BEYER, DR-ING.
RAINER RÖTHINGER, DIPL-PHYS.
BERNHARD THUM, DIPL-ING.
AXEL KATÉRLE, DIPL-ING.
SILVIA SCHICKER, DR-ING.
ERICH FRITSCHKE, DR. DIPL. NATW. ETH.
RAINER GUNZELMANN, DIPL-ING. (UNIV.)
RALPH-P. ANDERSEN, DR. DIPL-PHYS.

RECHTSANWÄLTE:
GERT WÜRTHENBERGER, DR. JUR.
ROLAND KUNZE, LL.M, SOLICITOR (ENGL.)
TANJA WITTMANN, LL.M. (TULANE UNIV.)
BERATEND / OF COUNSEL:
RUPERT GOETZ, DIPL-ING.
DIETER BEHRENS, DR-ING.
JÜRGEN BRANDES, DR. DIPL-CHEM.
E. FRHR. VON PECHMANN, DR. DIPL-CHEM.

By advance e-mail: fjjacobs@medic.up.ac.za

~~REGISTERED~~

Prof. Fred J. JACOBS
313 Vista Drive,
Faerie Glen,
Pretoria, 0043
SÜDAFRIKA

SCHWEIGERSTRASSE 2
81541 MÜNCHEN
TELEFON +49-89-62 18 00-0
TELEFAX +49-89-62 18 00-15
WUESTHOFF@WUESTHOFF.DE

27 May 2008
~~20 February 2008~~

National Phase in the USA 11/988,225 based on PCT/EP2006/006365
Title: Osteosynthesis plate comprising through-openings which are inclined in relation to the
plane of the plate
Applicant: Stryker Leibinger GmbH & Co. KG
Our ref.: 9A-99 164

Dear Prof. Jacobs,

At the request of Stryker Leibinger we enclose formal documents which require your signature and are necessary for entering the US national phase of the above referenced international patent application. Copies of the English application text as filed and the amended claims are also enclosed.

Please be so kind and sign these formal documents where marked and return them in the original to our office as soon as possible. As this is an urgent matter, we would highly appreciate your sending these documents also by advance e-mail.

If you have any questions, please do not hesitate to ask.

Yours sincerely,

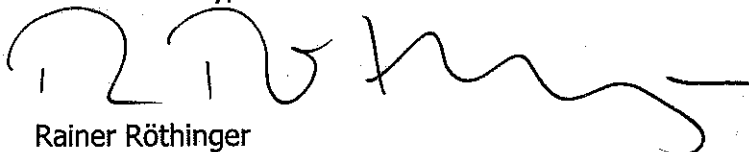

Rainer Röthinger

99

Enclosures

- Combined Declaration and Power of Attorney
- Assignment
- English application text
- Amended claims



**COMBINED DECLARATION AND POWER OF ATTORNEY
FOR UNITED STATES PATENT APPLICATION**

As a below named inventor, I hereby declare that:

My residence, post office address and citizenship are as stated near my name below.

I believe I am the original, first and joint inventors of the subject matter which is claimed and for which a patent is sought on the invention entitled:

**OSTEOSYNTHESIS PLATE COMPRISING THROUGH-OPENINGS WHICH ARE
INCLINED IN RELATION TO THE PLANE OF THE PLATE**

which is described and claimed in the specification of which:

_____ is attached hereto; attorney docket number _____.
X was filed on January 3, 2008 as United States Application Serial No. 11/988,225 which claims priority to and benefit of PCT International Application No. PCT/EP2006/006365, filed on June 30, 2006; attorney docket number 060500.00148.

I hereby state that I have reviewed and understand the contents of the above-identified specification, including the claims, as amended by any amendment specifically referred to above.

I do not know and do not believe my invention was known or used by others in the United States of America, or patented or described in a printed publication in any country before my invention thereof.

I do not know and do not believe my invention was patented or described in a printed publication in any country or in public use or on sale in the United States of America, more than one year prior to this application.

I acknowledge my duty to disclose information of which is material to patentability and to the examination of this application in accordance with Title 37, Code of Federal Regulations, Section 1.56.

I hereby claim that no application for patent or inventor's certificate on this invention has been filed in any foreign country or in the United States of America prior to this application by me or my legal representatives or assigns except as follows:



PRIORITY CLAIM

I hereby claim foreign priority benefits under Title 35, United States Code, §119(a)-(d) or (f), or § 365(b) of the foreign application(s) for patent, inventor's certificate(s), or § 365(a) of any PCT international application which designated at least one country other than the United States of America, listed below and have also identified below any foreign application(s) for patent, inventor's certificate(s), or any PCT international application having a filing date before that of the application of which priority is claimed.

 no such applications have been filed.
 X such applications have been filed as follows:

PRIOR FOREIGN APPLICATION NUMBER(S)	COUNTRY	FOREIGN FILING DATE	PRIORITY CLAIMED	CERTIFIED COPY ATTACHED
DE 10 2005 032 026.0	Germany	July 8, 2005	Yes <u> X </u> No <u> </u>	Yes <u> </u> No <u> X </u>

I hereby claim priority to and all the benefits under Title 35, United States Code, §119(e) of any United States provisional application(s).

 X no such applications have been filed.
 such applications have been filed as follows:

APPLICATION NUMBER	DATE OF FILING (month, day, year)
--------------------	-----------------------------------

I hereby claim priority to and all the benefits under Title 35, United States Code, §120 of any United States application(s) listed below. If the above identified application is a continuation-in-part application, I acknowledge the duty to disclose material information as defined in Title 37, Code of Federal Regulations, §1.56, which became available between the filing date of the prior application and the national or PCT international filing date of this continuation-in-part application.

 X no such applications have been filed.
 such applications have been filed as follows:

APPLICATION NUMBER	DATE OF FILING (month, day, year)	STATUS (patented, pending, abandoned)
--------------------	-----------------------------------	---------------------------------------



POWER OF ATTORNEY

As named inventor, I hereby appoint the attorneys and/or agent(s) associated with the below Customer Number to prosecute this application and transact all business in the Patent and Trademark Office connected therewith with full power of substitution and revocation.

CUSTOMER NUMBER: 27305

Please address all correspondence and telephone calls to:

PRESTON H. SMIRMAN, ESQ.
HOWARD & HOWARD ATTORNEYS, P.C.
The Pinehurst Office Center, Suite 101
39400 Woodward Avenue
Bloomfield Hills, Michigan 48304-5151
(248) 645-1483



DECLARATION

I hereby declare that all statements made herein of our own knowledge are true and that all statements made on information and belief are believed to be true; and further that these statements were made with the knowledge that willful false statements and the like so made are punishable by fine or imprisonment, or both, under Section 1001 of Title 18 of the United States Code and that such willful false statements may jeopardize the validity of the application or any patent issued thereon.

Dated: _____

15/07/2008

Fred J. Jacobs

Post Office and

Residence Address: 313 Vista Drive
Faerie Glen
0043 Pretoria
South Africa

Citizenship: South Africa



**ASSIGNMENT
(Patent Application - Single Inventor)**

WHEREAS I, **Fred J. Jacobs**, residing respectively 313 Vista Drive, Faerie Glen, 0043 Pretoria, South Africa, have invented certain new and useful improvements in an invention entitled

**OSTEOSYNTHESIS PLATE COMPRISING THROUGH-OPENINGS WHICH ARE
INCLINED IN RELATION TO THE PLANE OF THE PLATE**

which is set forth in a patent application in the United States as Serial No. 11/988,225 filed on January 3, 2008, Attorney Docket No. 060500.00148; and which claims foreign priority to PCT International Application No. PCT/EP2006/006365, filed on June 30, 2006; and German Patent Application No. 10 2005 032 026.0, filed on July 8, 2005.

WHEREAS, **STRYKER LEIBINGER GMBH & CO. KG.**, a corporation having its principal place of business at Bötzingers Strasse 41, 79111, Freiburg, Germany, hereinafter referred to as **ASSIGNEE**, is desirous of acquiring said invention and said patent application and any domestic and foreign patent or patents that may be obtained therefore or thereupon;

NOW, THEREFORE, TO ALL WHOM IT MAY CONCERN, be it known that for and in consideration of the sum of One United States Dollar (\$1.00), and other good and valuable considerations, the receipt of which is hereby acknowledged, I do hereby sell, assign, transfer and set over unto said **ASSIGNEE**, its successors, assigns, or other legal representatives, the full and entire right, title and interest in and to said invention and said patent application, including the right of said **ASSIGNEE**, its successors, assigns, or other legal representatives to file any and all divisional, continuation, and continuation-in-part applications claiming priority to said patent application, or the right to seek reissues or extensions of any patent that may be issued for said invention, with the same to be held and enjoyed by said **ASSIGNEE** as fully and entirely as the same would have been held by us had this Assignment and sale not been made; and

HEREBY AGREE that I, my heirs, successors, assigns or other legal representatives will at any time upon the request and at the expense of said **ASSIGNEE**, its successors, assigns, or other legal representatives, without undue delay, execute and deliver any and all papers and do all lawful acts that may be necessary or desirable to perfect the title to said invention, said applications, and any patent or patents that may be obtained therefore; and

HEREBY FURTHER ASSIGN unto said **ASSIGNEE**, its successors, assigns, or other legal representatives, the whole right, title and interest in and to said invention throughout all countries foreign to the United States, including the right to file any foreign



patent applications claiming priority to said patent application and otherwise seek any patent in any foreign country, and including the right to file any divisional, continuation, and continuation-in-part applications claiming priority to said foreign patent application where such procedure is proper, or the right to seek reissues or extensions of any patent in any foreign country, and we do hereby ratify any acts of said ASSIGNEE in applying for a patent in said ASSIGNEE's own name in any foreign country where such procedure is proper and do hereby agree to execute said foreign patent applications in the several countries where it is necessary that the same be executed by the inventors, and to execute assignments of said foreign patent applications and any patents to be obtained therefore to said ASSIGNEE; and

HEREBY AUTHORIZE and request the Commissioner of Patents and Trademarks of the United States and any official of any country foreign to the United States whose duty it is to issue patents, to issue any patent and any reissues and extensions thereof to said ASSIGNEE in accordance with this Assignment; and

HEREBY REPRESENT and warrant that I have the full right to convey the entire interest of said invention and said applications herein assigned and have not granted any rights inconsistent with the rights granted herein.

15/07/2008
Date

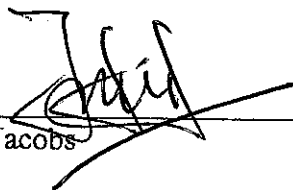
Fred J. Jacobs

Please address all correspondence and telephone calls and, upon recordation, please return this document to:

PRESTON H. SMIRMAN, ESQ.
HOWARD & HOWARD ATTORNEYS, P.C.
39400 Woodward Avenue, Suite 101
Bloomfield Hills, Michigan 48304-5151
(248) 723-1483



Osteosynthesis plate comprising through-openings which are inclined in relation to the plane of the plate

5

Field of the Invention

The present invention relates to an osteosynthesis plate with through openings inclined relative to the plane of the plate. Such osteosynthesis plates can be used to treat fractures in the region of the head and in particular to treat jaw fractures.

10

Background of the Invention

15

Osteosynthesis plates for the treatment of fractures have been known for more than 100 years. The most commonly used osteosynthesis plates have a linear (or elongated) shape and are provided with a plurality of through openings running perpendicular to the plane of the plate. In order to fix an osteosynthesis plate to a bone or bone fragment fastening elements (normally bone screws) are inserted through the through openings into the bone or bone fragment.

20

For individual cases it has proved convenient to form the through openings inclined relative to the plane of the plate. Often the provision of through openings inclined relative to the plane of the plate is connected with specific anatomical features or with special requirements, such as the generation of compression forces acting at specific angles.

25

In a linear osteosynthesis plate the alignment of through openings inclined relative to the plane of the plate can in principle be uniquely described by two angles α and β . This situation will now be described with reference to Figs. 17 and 18.

30

As illustrated in Fig. 17, a first angle α denotes the inclination of a through opening O with respect to a line S perpendicular to the plane of the plate. The plane of the plate in Fig. 10 is inclined perpendicular to the plane of the drawing. A second angle β denotes according to Fig. 18 an angular alignment of the through opening O within the plane of the plate with respect to a plate longitudinal axis L. The plane of the plate runs in Fig. 18 parallel to the plane of the drawing.

35



The angles α and β provide an unambiguous angular characterisation by restricting the first angle α to the range from 0° to 90° and having the second angle β run from 0° to 360° . In the following discussion all angles are given in the anticlockwise direction and relative to a directed reference line (for example relative to a plate longitudinal axis pointing in a specific direction).

In US 5,588,674 in Figs. 5 and 6 a linear osteosynthesis plate is illustrated, which comprises a total of four through openings inclined to the plane of the plate. Each of these four through openings intersects the plane of the plate approximately at an angle of inclination $\alpha = 45^\circ$. The inclined through opening 26b has an angular alignment $\beta = 0^\circ$ with respect to a plate longitudinal axis pointing to the free end 21 of the osteosynthesis plate 20. The remaining three inclined through openings have an opposite angular alignment $\beta = 180^\circ$.

From DE 199 62 317 A1 a linear osteosynthesis plate is known with two through openings aligned perpendicular to the plane of the plate and two through openings inclined to the plane of the plate. In this osteosynthesis plate the two through openings inclined to the plane of the plate have in each case an angle of inclination α of approximately 65° with respect to a straight line perpendicular to the plane of the plate. The angular alignment within the plane of the plate is in the case of the first inclined through opening $\beta = 0^\circ$ with respect to the plate longitudinal axis, and in the case of the second inclined through opening $\beta = 180^\circ$.

From Christian Krenkel, *Biomechanics and Osteosynthesis of Condylar Neck Fractures of the Mandible*, Quintessence Publishing Co., Inc. Carol Stream, Illinois, 1994, pp. 56 to 60, further linear osteosynthesis plates are known, which are used to treat fractures of the lower jaw. Since for aesthetic reasons (in order to avoid facial scars) fractures in the region of the lower jaw should be treated by surgical intervention from underneath the jaw, the through openings of the osteosynthesis plates are formed inclined to the plane of the plate. In the proposed osteosynthesis plates the angle of inclination α is between 30° and 90° . The angular alignment β of the through openings is either 0° , 45° , 90° or 135° .

The object of the invention is to provide an osteosynthesis plate for the treatment of fractures, in particular fractures in the region of the head such as lower jaw fractures, which can be fixed in a simple manner and with improved functionality to the bone.



Summary of the Invention

This object is achieved by an osteosynthesis plate with a plane of the plate, with a linear first section with a first longitudinal axis and extending substantially within the plane of the plate, with a linear second section with a second longitudinal axis and extending substantially within the plane of the plate inclined or staggered with respect to the first section, with at least one first through opening in the first section, which is inclined to the plane of the plate and has with respect to the first longitudinal axis a first angular alignment within the plane of the plate, and at least one second through opening in a second section, which is inclined to the plane of the plate and has with respect to the first longitudinal axis of the first section a second angular alignment within the plane of the plate, wherein the first and second angular alignments with respect to the first longitudinal axis differ from one another by less than about 60° .

Although the osteosynthesis plate at least in the basic state or as-supplied state extends substantially within a general plane of the plate, this does not prevent the plate or individual sections of the plate from being bent outwards from the plane of the plate before or during use. Thus, it may be convenient to adapt the osteosynthesis plate before its securement to a bone and/or bone fragment, by bending it to match the specific anatomical features of the fracture region. This matching is as a rule carried out by the operating surgeon. It is however also possible for the osteosynthesis plate to be bent outwards to some extent from the general plane of the plate already in the as-supplied state, so as to match anatomical features. Such osteosynthesis plates are included in the scope of protection of the invention.

The angular alignments of the first through opening and of the second through opening with respect to the first longitudinal axis serving as reference axis may be identical or different. Often angular alignments differing somewhat from one another by more than 0° or more than 10° (up to about 60° or up to about 45°) with respect to the first longitudinal axis are suitable for purposes of manipulation. It is also possible for the first angular alignment to be inclined to the first longitudinal axis and/or for the second angular alignment to be inclined to the second longitudinal axis. This means in the diagram in Fig. 18 that the angle β is chosen to be different from 0° and also different from 180° . Thus, the angle β can be chosen to be between approximately 10° and 170° , or between approximately 190° and 350° .



The angles of the first through opening and of the second through opening inclined to the plane of the plate (i.e. the angle of inclination α in the diagram of Fig. 17) can be chosen to be identical or different. The first through opening can intersect the plane of the plate at an angle of inclination of approximately 20° to 80° . Also, an angle of inclination within the range from approximately 30° to 70° is also feasible. The angle of inclination at which the second through opening intersects the plane of the plate can likewise vary in these angular ranges from approximately 20° to 80° or from approximately 30° to 70° .

According to a first variant the first angular alignment to the first longitudinal axis is between approximately $+90^\circ$ and -90° , between approximately $+60^\circ$ and -60° or between approximately $+40^\circ$ and -40° (for example with respect to a direction facing away from the second section or facing towards a free end of the first section). According to a second variant, which can be combined with the first variant, the second angular alignment with respect to the second longitudinal axis is between approximately 60° and 180° or between approximately 70° and 130° (for example with respect to a direction facing away from the first section or a direction facing towards a free end of the second section). According to a third variant, which can be combined with the first variant, the second angular alignment to the second longitudinal axis is between approximately 180° and 300° or between approximately 220° and 290° (for example with respect to a direction facing away from the first section or a direction facing towards a free end of the second section). The second variant and the third variant can be used for osteosynthesis plates for different halves of the body (right/left).

The first section and the second section can directly adjoin one another or can be connected to one another by one or more connecting sections. The connecting sections can have a linear or bent shape.

In the case of a second section inclined to the first section, the angle between the first section and the second section can be between approximately 90° to 160° and in particular between approximately 110° to 150° . The first section and the second section (or their longitudinal axes) can also run parallel and staggered with respect to one another. In this case at least one connecting section is provided between the first section and the second section. The at least one connecting section can extend inclined or perpendicular to the first and second section.



In order to enable a surgeon to carry out more easily the already mentioned matching of the osteosynthesis plate to the relevant anatomical features, the osteosynthesis plate can comprise at least one bending region of reduced plate thickness and/or reduced plate width and/or of meandering shape. According to a first variant the bending region (for example as connecting section) is formed at the transition between the first section and the second section. According to a second variant, which can be combined with this first variant, the bending region is provided between two adjacent through openings.

The osteosynthesis plate is dimensioned depending on the surgical situation in each case. In particular, in cases involving the lower jaw region the first section of the osteosynthesis plate can have a length between approximately 3 and 100 mm (for example between 5 and 60 mm and preferably between 6 and 25 mm) and the second section can have a length between approximately 3 and 100 mm (for example between 5 and 60 mm and preferably between 6 and 25 mm). The overall length of the plate can vary between 6 and 200 mm.

The osteosynthesis plate can in the region of the first section and/or in the region of the second section have a maximum plate thickness between approximately 0.5 and 3.5 mm. In one possible configuration the plate thickness is chosen so that a head of a fastening element (in any case most of it) can be sunk or embedded in the plate. In order to support the embedding of the head, the at least one first through opening and/or the at least one second through opening can include underneath a plate surface a stop means for the head of the fastening element.

In order to provide a reliable securement of the osteosynthesis plate, a plurality (for example at least 2 to approximately 5) first through openings and a plurality (for example at least 2 to approximately 5) second through openings are provided. In this connection the mutual interspacing of the first through openings can be different from the mutual interspacing of the second through openings. This arrangement is particularly convenient if the length of the first section differs from the length of the second section. The through openings can have a diameter of approximately 1.5 to 3.5 mm, preferably approximately 2 to 3 mm.

Brief Description of the Drawings

Further implementations and advantages of the invention follow from the following description of preferred embodiments and from the figures, in which:



- Figs. 1 and 2 each show a plan view of a first embodiment of an osteosynthesis plate;
- 5 Fig. 3 is a section along the line A-A in Fig. 1;
- Fig. 4 is a section along the line B-B in Fig. 2;
- Fig. 5 is a section along the line C-C in Fig. 1;
- 10 Fig. 6 is a side view of the osteosynthesis plate of the first embodiment;
- Fig. 7 is a perspective view of the osteosynthesis plate of the first embodiment;
- 15 Figs. 8A and 8B each show a perspective view of the osteosynthesis plate of the first embodiment with bone screws accommodated in through openings;
- 20 Fig. 9 is a view of a second embodiment of an osteosynthesis plate;
- Fig. 10 is a perspective view of a third embodiment of an osteosynthesis plate;
- 25 Figs. 11A and 11B each show a perspective view of a fourth embodiment of an osteosynthesis plate with bone screws accommodated in through openings;
- 30 Figs. 12A and 12B each show a perspective view of a fifth embodiment of an osteosynthesis plate with bone screws accommodated in through openings;
- 35 Figs. 13A and 13B each show a perspective view of a sixth embodiment of an osteosynthesis plate with bone screws accommodated in through openings;



Figs. 14A and 14B show two perspective views of a further osteosynthesis plate, in particular for treating jaw fractures;

5 Figs. 15A and 15B show in the linear base state and bent application state a further osteosynthesis plate, in particular for treating jaw fractures;

10 Fig. 16 shows in the linear base state a further osteosynthesis plate, in particular for treating jaw fractures;

15 Fig. 17 is a diagrammatic representation of the angle of inclination α between a through opening inclined relative to the plane of the plate, and the plane of the plate itself; and

20 Fig. 18 is a diagrammatic representation of the angular alignment β within the plane of the plate for a through opening inclined relative to the plane of the plate.

25 Description of Preferred Embodiments

30 The osteosynthesis plate according to the invention is discussed hereinafter with the aid of several embodiments. Identical and corresponding elements are identified here by the same reference numeral.

35 Figs. 1 and 2 show in each case a plan view of a first embodiment of an osteosynthesis plate 10 in different alignments. Figs. 3 to 7 and Figs. 8A and 8B show further views of this osteosynthesis plate 10.

40 The osteosynthesis plate 10 consists of titanium and is suitable in particular for treating jaw fractures (in particular fractures in the region of the mandibular angle). The osteosynthesis plate 10 illustrated in Figs. 1 to 7, 8A and 8B is a plate for the right-hand mandibular angle. The plate illustrated in Fig. 9 is intended for the left-hand mandibular angle. The left-hand osteosynthesis plate of Fig. 9 is the mirror image counterpart of the right-hand osteosynthesis plate 10. For this reason the description of the right-hand osteosynthesis plate 10 applies, apart from a few exceptions, also to the left-hand osteosynthesis plate according to Fig. 9. The exceptions will be discussed in more detail in connection with the description of Fig. 9.

The osteosynthesis plate 10 according to the first embodiment extends in the as-supplied state within a general plane of the plate, which in Figs. 1 and 2 runs parallel to the plane of the drawing. The osteosynthesis plate 10 has two adjoining linear plate sections 12, 14 with associated longitudinal axes 16, 18. The two plate sections 12, 14 run inclined to one another within the plane of the plate. As can be seen from Fig. 1, the angle of intersection between the longitudinal axes 14, 16 of the two plate sections 12, 14 is approximately 130° in the illustrated embodiment. The length of the plane section 12 (measured from the point of intersection of the two longitudinal axes 16, 18 up to the free end of the section 12) is approximately 14 mm, and the length of the plate section 14 (measured from the point of intersection of the two longitudinal axes 16, 18 up to the free end of the section 14) is approximately 10 mm.

Three identically shaped through openings 20 are formed in the plate section 12, and three likewise identically shaped through openings 22 are formed in the plate section 14. The through openings 20, 22 have a diameter of 2.4 mm in the narrowest region.

The through openings 20 in the plate section 12 intersect the plane of the plate at an angle of inclination $\alpha = 60^\circ$. This situation can be seen in Fig. 3, which shows a section along the line A-A of Fig. 1. The through openings 22 of the plate section 14 intersect the plane of the plate similarly at an angle of inclination of $\alpha = 60^\circ$. This can be seen in Fig. 4, which shows a section along the line B-B of Fig. 2. As regards the definition of the angle α , reference should be made to Fig. 17.

The through openings 20 of the plate section 12 have within the plane of the plate an angular alignment of $\beta = 0^\circ$ with respect to the longitudinal axis 16. The angular alignment with respect to the longitudinal axis 16 is determined in the direction of a free end of the plate section 12. The through openings 22 of the plate section 14 have within the plane of the plate an angular alignment of $\beta = 270^\circ$ with respect to the longitudinal axis 18 (and in the direction of the free end of the plate section 14). The through openings 22 have an angular alignment $\beta = 40^\circ$ with respect to the longitudinal axis 16 of the plate section 12 (again referred to the direction of the free end of the plate section 12). The angular alignment of $\beta = 40^\circ$ of the through openings 22 of the plate section 14 with respect to the longitudinal axis 16 of the plate section 12 is shown in Fig. 1. As regards the determination of the angle β , reference should be made to Fig. 18.



In the osteosynthesis plate 10 according to Figs. 1 to 7, 8A and 8B the through openings 20 consequently have an angular alignment in the plane of the plate of $\beta = 0^\circ$ and the through openings 22 have an angular alignment in the plane of the plate of $\beta = 40^\circ$ (in each case referred to the longitudinal axis 16 of the plate section 12).

5 The difference in the angular alignments of the through openings 20 and of the through openings 22 within the plane of the plate is therefore approximately 40° .

10 As can readily be recognised especially in Figs. 3 and 4, the through openings 20 in the plate section 12 (just as the through openings 22 in the plate section 14) have an internal diameter that reduces in a step-wise manner in the direction of the lower side of the plate 24. In this way a bearing surface 26 acting as a stop means for the head of a securement element is formed in each case within the through openings 20, 22. The bearing surface 26 is formed underneath the plate surface 28 and above the lower side of the plate 24. Since in any case the lowest region of the bearing surface 26 (cf. Fig. 5) lies underneath the plate surface 28, the head of a securement element inserted into the through openings 20, 22 can be sunk at least partly in the osteosynthesis plate 10.

20 In Fig. 8A it can clearly be seen that the shanks 50 of bone screws 48 in the plate section 12 run up to the different angular alignment ($\Delta\beta = 40^\circ$) substantially parallel to the shanks 50 of bone screws 48 in the plate section 14. Furthermore, it can readily be seen in the illustration according to Fig. 8A that the heads 52 of the bone screws 48 are accommodated sunk relative to the upper side of the plate.

25 With respect to Fig. 8B it should also be mentioned that the auxiliary lines 16', 18' shown there and running perpendicular to the longitudinal axes 14, 16 serve to illustrate the angular alignment region β . As shown in Fig. 8B, the angular alignment β with respect to the auxiliary lines 16', 18' can vary by $\pm 90^\circ$, preferably by approximately 60° .

30 The planar osteosynthesis plate 10 in the as-supplied state has a plurality of bending regions of reduced plate thickness or reduced plate width. These bending regions enable the surgeon to adapt and match the osteosynthesis plate 10 to the anatomical features in the fracture region. In this connection the osteosynthesis plate 10 can by means of suitable tools such as bending forceps be bent within the plane of the plate as well as outwardly from the plane of the plate.

5 A first bending region 30 of the osteosynthesis plate 10 is according to Fig. 1 arranged at the transition between the plate section 12 and the plate section 14. As can be seen from the side view according to Fig. 6, the osteosynthesis plate 10 has in the bending region 30 a minimal width and a lower height than in regions outside the bending region 30. This step-wise reduction of the plate thickness (from a maximum ca. 2 mm outside the bending region 30 to ca. 1.5 mm in the bending region 30) and of the plate width facilitates the bending of the osteosynthesis plate 10 by the surgeon.

10 A plurality of second bending regions 32 are according to Fig. 1 formed in each case between two adjacent through openings 20 of the plate section 12 and also between two adjacent through openings 22 of the plate section 14. These further bending regions 32 are formed by regions of reduced plate width.

15 Fig. 9 shows the left-hand osteosynthesis plate 10 of a plate system, which also includes the right-hand osteosynthesis plate described above with reference to Figs. 1 to 7, 8A and 8B. As already mentioned, the left-hand osteosynthesis plate 10 is the mirror symmetrical counterpart to the right-hand osteosynthesis plate. Accordingly the basic difference compared to the right-hand osteosynthesis plate is that the
20 through openings 22 of the plate section 14 have a different angular alignment within the plane of the plate. Whereas in the right-hand plate the corresponding angular alignment $\beta = 270^\circ$, the through openings 22 of the left-hand osteosynthesis plate 10 have with respect to the longitudinal axis 18 and in the direction of the free end of the plate section 14, a mirror image-forming angular alignment $\beta = 90^\circ$. The
25 difference in the angular alignments of the through openings 22 of the plate section 14 and of the through openings 20 of the plate section 12 (in each case referred to the longitudinal axis 16) is a constant 40° .

30 Fig. 10 shows a further embodiment of an osteosynthesis plate 10 for treating fractures in the jaw region. The osteosynthesis plate 10 has two plate sections 12, 14, which are arranged parallel and staggered with respect to one another. Between the two plate sections 12, 14 is provided a connecting section 40, running inclined to each of these sections 12, 14. The connecting section 40 intersects the two plate sections 12, 14 at an angle of in each case approximately 140° .

35 Three identical through openings 20, 22 are formed in each case in each of the two plate sections 12, 14. The through openings 20, 22 intersect the plane of the plate at an angle of inclination $\alpha = 45^\circ$. With respect to the longitudinal axis 16 of the



plate section 12 and in the direction of the free end of the plate section 12 the angular alignment β of the through openings 20 within the plane of the plate is $\beta = 135^\circ$. The angular alignment β of the through openings 22 with respect to the longitudinal axis 18 of the plate section 14 and in the direction of the free end of the plate section 14 is $\beta = 45^\circ$. Referred to the longitudinal axis 16 of the plate section 12 and the free end of the plate section 12, the angular alignment β of the through openings 22 of the plate section 14 is $\beta = 135^\circ$. The angular alignments of the through openings 20 and of the through openings 22 therefore coincide with respect to the longitudinal axis 16 of the plate section 12.

A further embodiment of an osteosynthesis plate 10 for treating fractures of the mandibular angle is illustrated in Figs. 11A and 11B. The illustrated osteosynthesis plate 10 is substantially identical to the osteosynthesis plate 10 discussed with reference to Figs. 1 to 7, 8A and 8B, except as regards the angular alignments of the through openings. For this reason only the differences will be discussed hereinafter.

A further embodiment of an osteosynthesis plate 10 is illustrated in Figs. 11A and 11B. In this embodiment the two plate sections 12, 14 again enclose an angle of 130° . The through openings 20, 22 have in each case an angle of inclination $\alpha = 60^\circ$ with respect to the plane of the plate. The angular alignment of the through openings 20 of the plate section 12 within the plane of the plate (and referred to the free end of the plate section 12) is in this embodiment 90° . As in the first embodiment, the through openings 22 of the plate section 14 within the plane of the plate have with respect to the longitudinal axis 18 (and in the direction of the free end of the plate section 14) an angular alignment of $\beta = 270^\circ$. The difference of the angular alignments of the through openings 20 and of the through openings 22 within the plane of the plate is approximately 50° . The angular alignments of the through openings 20 and 22 can vary from the specified angular alignments by $\pm 90^\circ$, preferably by approximately $\pm 60^\circ$.

A further embodiment of an osteosynthesis plate 10 is illustrated in Figs. 12A and 12B, with a total of three plate sections 12, 14, 14' and a total length of approximately 40 mm. The osteosynthesis plate 10 has a substantially fork-shaped configuration. The two plate sections 14, 14' run parallel and staggered with respect to the longitudinal axis 16 of the section 12. The plate section 12 is connected to the plate sections 14, 14' by a connecting section 40, 40' bent in each case in the shape of a quarter circle.



The fork-shaped configuration of the osteosynthesis plate 10 is determined by the fact that the two plate sections 14, 14' accommodate a nerve between them (for example in the region of the lower jaw). In this way damage to the nerve due to the bone screw 48 can be avoided.

5

The through openings 20 of the plate section 12 of the osteosynthesis plate 10 and also the through openings 20, 20' of the plate sections 14, 14' intersect the plane of the plate in each case at an angle of inclination $\alpha = 60^\circ$. The through openings 20 of the plate section 12 have within the plane of the plate an angular alignment $\beta = 0^\circ$ with respect to the longitudinal axis 16 and in the direction of a free end of the plate section 12. The through openings 22, 22' of the plate sections 14, 14' have within the plane of the plate an angular alignment $\beta = 180^\circ$ relative to the respective longitudinal axis 18, 18' (and in the direction of the respective free end of the plate section 14, 14'). The through openings 22, 22' have an angular alignment $\beta = 0^\circ$ with respect to the longitudinal axis 16 of the plate section 12 (again referred to the direction of the free end of the plate section 12). The difference in the angular alignments of the through openings 20 and of the through openings 22, 22' within the plane of the plate is therefore 0° .

10

15

20

A further embodiment of an osteosynthesis plate 10 is illustrated in Figs. 13A and 13B. The osteosynthesis plate 10 illustrated there has a substantially grid-shaped configuration with two plate sections 12, 14 running parallel and staggered with respect to one another. The plate sections 12, 14 are joined to one another in the region of oppositely located through openings 20, 22 by in each case a connecting section 40. In the example illustrated in Figs. 13A and 13B, with two times three through openings 20, 22 (i.e. three per plate section 12, 14), three connecting sections 40 are therefore provided. The connecting sections 40 run parallel to one another and in this example intersect the plate section 12, 14 at a right angle. A modification of the osteosynthesis plate 10 illustrated in Figs. 13A and 13B could have, instead of two times three through openings, two times four or three times four through openings.

25

30

35

The through openings 20, 22 of the osteosynthesis plate 10 of Figs. 13A and 13B intersect the plane of the plate in each case at an angle of inclination $\alpha = 60^\circ$. The through openings 20 of the plate section 12 have within the plane of the plate an angular alignment $\beta = 90^\circ/270^\circ$ with respect to a longitudinal axis of the plate section 12 (in the example of Figs. 13A and 13B there is no preferred direction). The through openings 22 of the plate section 14 have the same angle of alignment

$\beta = 90^\circ/270^\circ$ with respect to a longitudinal axis of the plate section 14. Accordingly the difference in the angular alignments of the through openings 20 and of the through openings 22 within the plane of the plate is 0° .

5 A further osteosynthesis plate 10 with two plate sections 12, 14 is illustrated in Figs. 14A and 14B. The two plate sections 12, 14 have a common longitudinal axis 16 and are connected to one another via a meandering (U-shaped) bent connecting section 40. The osteosynthesis plate 10 can in the application state be positioned in such a way that the U-shaped bent connecting section 40 extends around a nerve. In a
10 modification of the osteosynthesis plate 10 according to Figs. 14A and 14B, at least one bone screw through opening is provided in the region of the connecting section 40.

15 The through openings 20, 22 intersect the plane of the plate in each case at an angle of inclination $\alpha = 60^\circ$. The through openings 20 of the plate section 12 have within the plane of the plate an angular alignment $\beta = 90^\circ$ with respect to the common longitudinal axis 16 (and in the direction of the free end of the plate section 12). The through openings 22 of the plate section 14 have an angular alignment $\beta = 270^\circ$
20 with respect to the common longitudinal axis 16 and with respect to the free end of the plate section 14. The difference in the angular alignments of the through openings 20 and of the through openings 22 within the plane of the plate is consequently 0° .

25 Figs. 14A and 14B show the osteosynthesis plate 10 in the base state. According to a further embodiment of the invention the osteosynthesis plate 10 can in the region of the connecting section 40 (which then acts as bending region) be deformed in such a way that the plate section 12 is inclined relative to the plate section 14.

30 A further osteosynthesis plate 10 is illustrated in Figs. 15A and 15B. The osteosynthesis plate 10 has in the base state illustrated in Fig. 15A a linear configuration with a total of eight through openings 20. The through openings 20 intersect the plane of the plate at an angle $\alpha = 60^\circ$ and have within the plane of the plate an angular alignment $\beta = 90^\circ/270^\circ$ (there is no preferred direction). The angular alignment β can vary by $\pm 90^\circ$, preferably by approximately $\pm 60^\circ$, with respect to the auxiliary
35 line 16' shown in Fig. 15B.

Fig. 15B shows the osteosynthesis plate 10 in the bent application state. The osteosynthesis plate 10 is in this example secured in the region of the front side of the



lower jawbone (therefore in the chin region) and its bent shape matches the contour of this bone. Since the through openings 20, 22 point inclined upwards, the screws 48 can be inserted intraorally (and in particular inclined from above).

5 The osteosynthesis plate according to Figs. 15A, 15B can according to a further embodiment of the invention be deformed within the plane of the plate similarly as shown in Fig. 10, in such a way that two linear plate sections running parallel and staggered with respect to one another are formed.

10 A further osteosynthesis plate 10 is illustrated in Fig. 16. The osteosynthesis plate 10 has a linear configuration and comprises two plate sections 12, 14 connected to one another via a connecting section shaped as a bending region 30. The through openings 20, 22 of the plate sections 12, 14 have an angle of inclination $\alpha = 60^\circ$ with respect to the plane of the plate. The angular alignments of the through openings 20, 22 are in each case $\beta = 180^\circ$ with respect to the free ends of the respective
15 plate section 12, 14. The difference in the angular alignments of the through openings 20 and of the through openings 22 is accordingly 180° .

20 According to an embodiment of the invention the osteosynthesis plate 10 illustrated in Fig. 16 is bent at the site of the bending region 30 in such a way that the two plate sections 12, 14 are inclined to one another in a substantially V-shaped manner.

25 The osteosynthesis plates discussed with reference to Figs. 1 to 11B are suitable for the intraoral treatment of fractures of the mandibular angle. The osteosynthesis plates described with reference to Figs. 12A to 16 are suitable for the intraoral treatment of jaw fractures in jaw regions spaced from the mandibular angle, for example in the region of the chin or condylus.

30 The existence of two or more plate sections that are aligned non-linearly with respect to one another enables even complicated jaw fractures to be treated by means of a single osteosynthesis plate. The alignment of the individual through openings in the plane of the plate and perpendicular thereto is chosen in the embodiments in such a way that the osteosynthesis plates can be fastened *in situ* by an intraoral surgical intervention, i.e. through the mouth. No transbuccal access (i.e. through the cheek)
35 is therefore necessary in order to place in position the osteosynthesis plates of the embodiments and secure them by means of suitable securement elements such as monocortical bone screws.



5 On account of the special alignment of the through openings the surgeon is able to place in position an osteosynthesis plate intraorally, carry out if necessary preliminary drillings, and then secure the osteosynthesis plate by means of several bone screws, all without the need for a transbuccal access. Conventional (longitudinally extended) straight instruments such as blades and drills are sufficient for carrying out these steps. The use of curved instruments can be dispensed with. A further advantage of the alignment of the through openings specified in the embodiments is the fact that the surgeon, despite the intraoral access, has a good field of view and can thus see exactly where he is drilling and where the bone screws are placed.

10 Although the invention has been described with the aid of several embodiments of osteosynthesis plates for treating jaw fractures, the osteosynthesis plates according to the invention are also suitable for minimal invasive treatment of other fractures in the head region (for example the face).

15 On the basis of the above description and discussion the person skilled in the art will be able to employ numerous changes, additions and modifications that are still covered by the invention. The scope of protection of the invention is limited solely by the accompanying patent claims.



Patent Claims

1. Osteosynthesis plate (10), in particular for treating jaw fractures, with
 - a plane of the plate;
 - 5 - a linear first section (12) with a first longitudinal axis (16) and extending substantially within the plane of the plate;
 - a linear second section (14) with a second longitudinal axis (18) and extending substantially within the plane of the plate and inclined or staggered with respect to the first section (12);
 - 10 - at least one first through opening (20) in the first section (12), which is inclined to the plane of the plate and has, with respect to the first longitudinal axis (16), a first angular alignment within the plane of the plate; and
 - at least one second through opening (22) in the second section (14),
15 which is inclined to the plane of the plate and has with respect to the first longitudinal axis (16) of the first section (12) a second angular alignment within the plane of the plate, wherein the first and second angular alignments differ with respect to the first longitudinal axis (16) from one another by less than about 60°.
 - 20
2. Osteosynthesis plate according to claim 1, characterised in that the first and the second angular alignments differ with respect to the first longitudinal axis (16) from one another by less than about 45°.
- 25 3. Osteosynthesis plate according to claim 1 or 2, characterised in that the first angular alignment is inclined to the first longitudinal axis (16) and/or the second angular alignment is inclined to the second longitudinal axis (18).
4. Osteosynthesis plate according to one of claims 1 to 3, characterised in that
30 the at least one first through opening (20) intersects the plane of the plate at an angle of approximately 20° to 80°.
5. Osteosynthesis plate according to one of claims 1 to 4, characterised in that
35 the at least one second through opening (22) intersects the plane of the plate at an angle of approximately 20° to 80°.



6. Osteosynthesis plate according to one of claims 1 to 5, characterised in that the first angular alignment with respect to the first longitudinal axis (16) is between approximately $+90^\circ$ and -90° .

5 7. Osteosynthesis plate according to one of claims 1 to 6, characterised in that the second angular alignment with respect to the second longitudinal axis (18) is between approximately 60° and 180° .

10 8. Osteosynthesis plate according to one of claims 1 to 7, characterised in that the second angular alignment with respect to the second longitudinal axis (18) is between approximately 180° and 300° .

15 9. Osteosynthesis plate according to one of claims 1 to 8, characterised in that the first section (12) and the second section (14) directly adjoin one another.

10. Osteosynthesis plate according to one of claims 1 to 9, characterised in that the first section (12) has an angle of approximately 90° to 160° with respect to the second section (14).

20 11. Osteosynthesis plate according to one of claims 1 to 10, characterised in that the first longitudinal axis (16) and the second longitudinal axis (18) run parallel to one another and at least one connecting section (40) is provided between the first section (12) and the second section (14).

25 12. Osteosynthesis plate according to one of claims 1 to 11, characterised in that the osteosynthesis plate (10) comprises at least one bending region (30, 32, 40) of reduced plate thickness and/or of reduced plate width and/or of meandering shape.

30 13. Osteosynthesis plate according to one of claims 1 to 12, characterised in that the first section (12) has a length between approximately 5 and 70 mm and/or the second section (14) has a length between approximately 5 and 70 mm.

35 14. Osteosynthesis plate according to one of claims 1 to 13, characterised in that the osteosynthesis plate (10) in the region of the first section (12) and/or in the region of the second section (14) has a maximum plate thickness between approximately 0.5 and 3.5 mm.



15. Osteosynthesis plate according to one of claims 1 to 14, characterised in that the at least one first through opening (20) and/or the at least one second through opening (22) has underneath a plate surface (28) a stop means (26) for a head of a fastening element.

5

16. Osteosynthesis plate according to one of claims 1 to 15, characterised in that a plurality of first through openings (20) and/or a plurality of second through openings (22) are provided.

10



Abstract

Osteosynthesis plate with through openings inclined to the plane of the plate

5 An osteosynthesis plate is described, which is suitable for treating jaw fractures. The
osteosynthesis plate has a plane of the plate as well as two plate sections 12, 14 with
associated longitudinal axes 16, 18 extending substantially within the plane of the
plate and inclined or staggered with respect to one another. Through openings 20,
22 inclined to the plane of the plate are formed in each of the two plate sections 12,
10 14. The angular alignments of the through openings 20, 22 within the plane of the
plate differ with respect to a longitudinal axis 16 serving as reference line from one
another by less than approximately 60° . In applications in the jaw region this slight
deviation of the angular alignments permits an intraoral securement of the osteosyn-
thesis plate. A transbuccal access through the cheek can thus be dispensed with.

15

(Fig. 9)

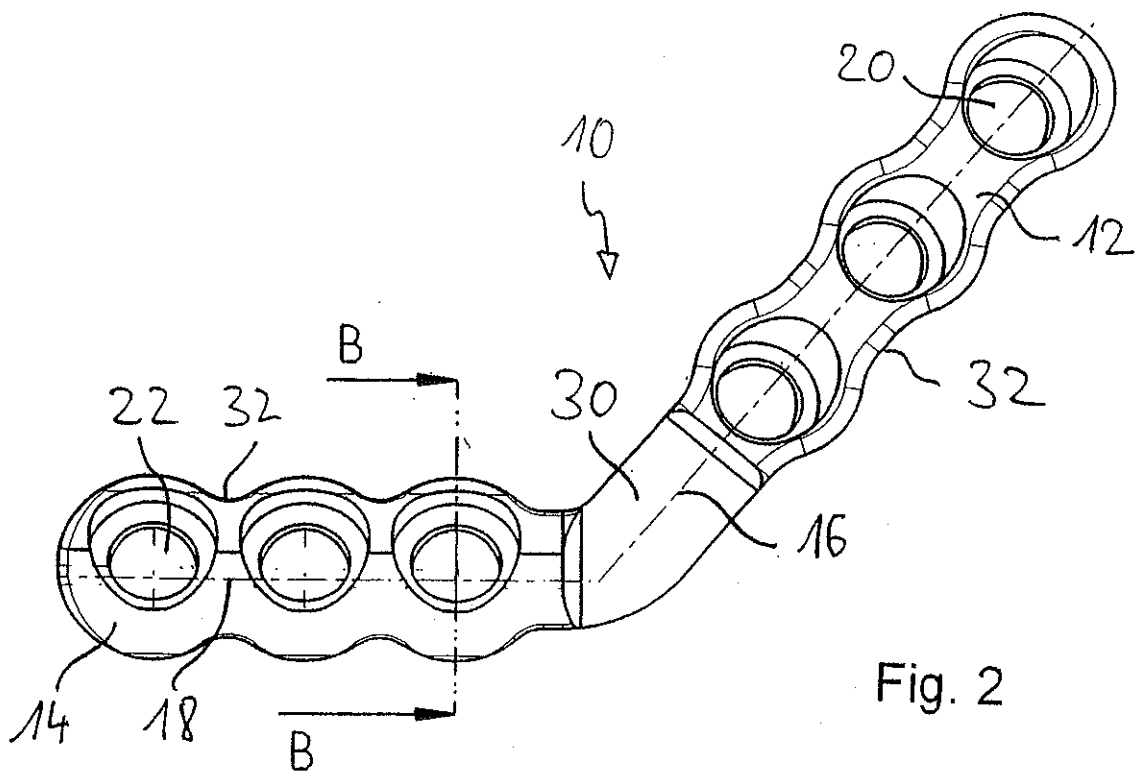
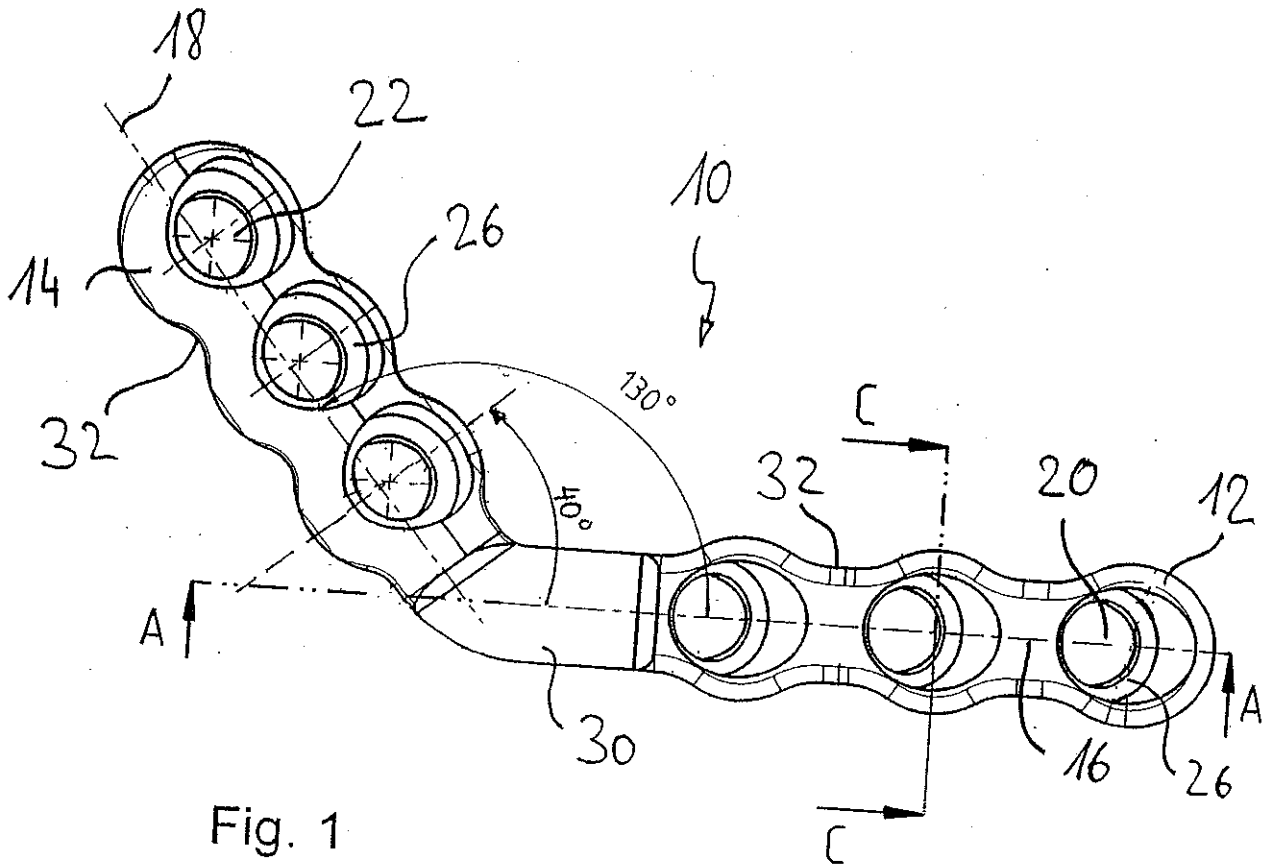

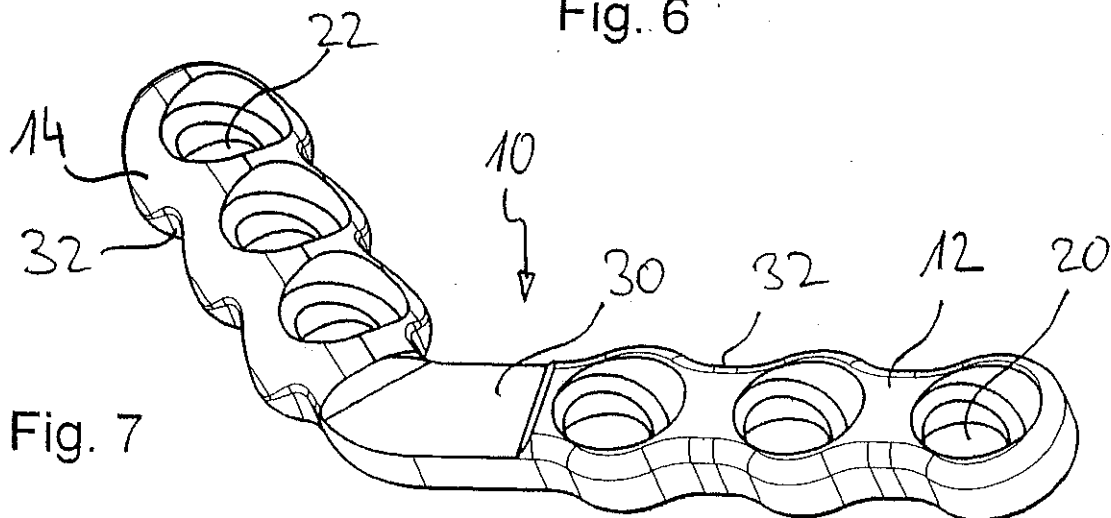
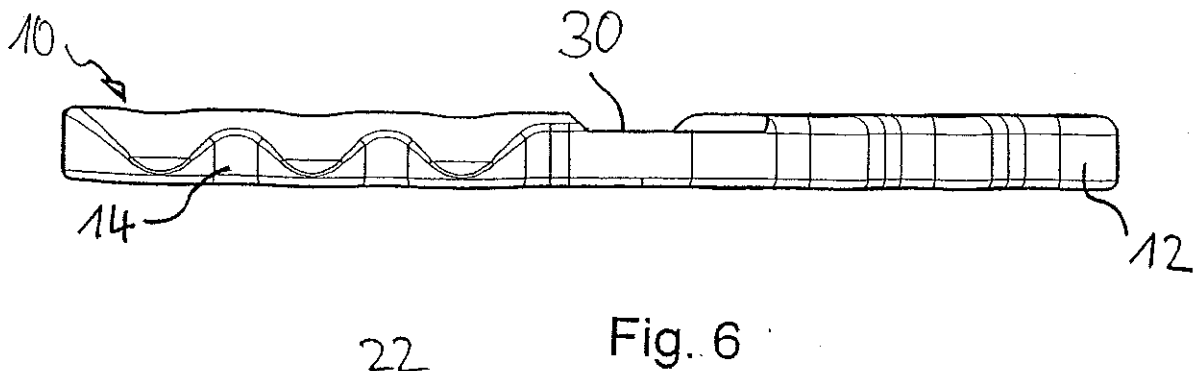
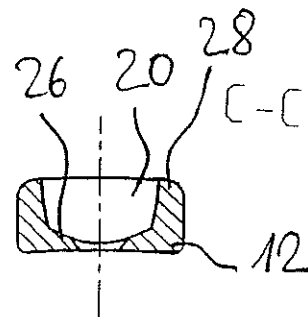
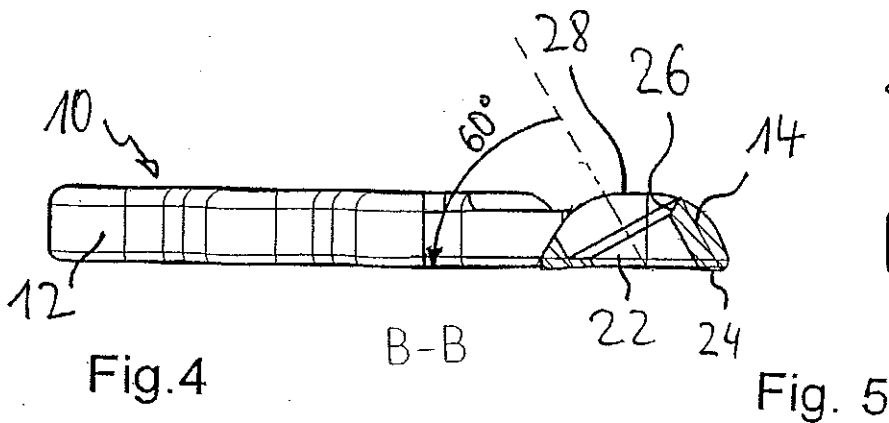
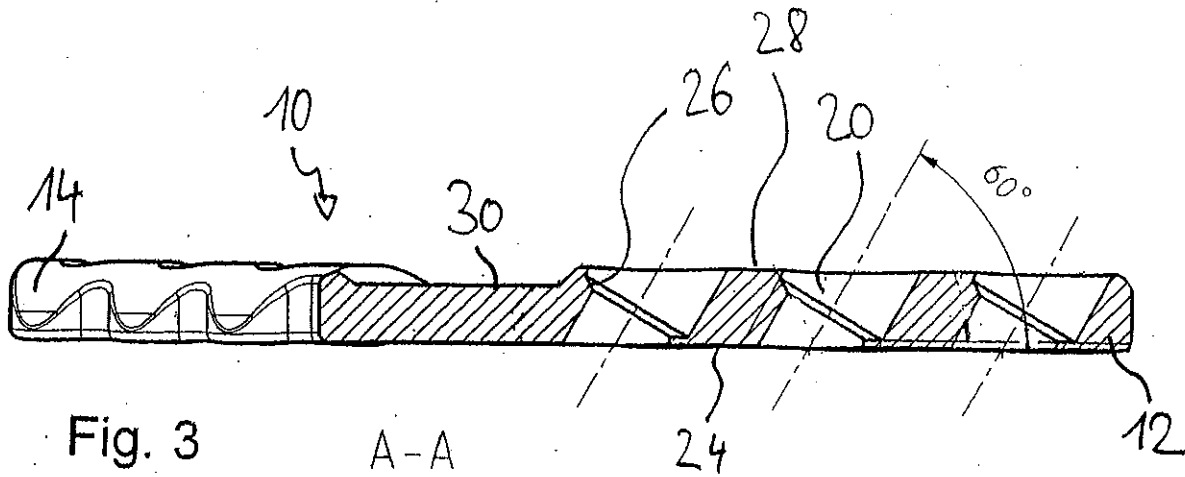

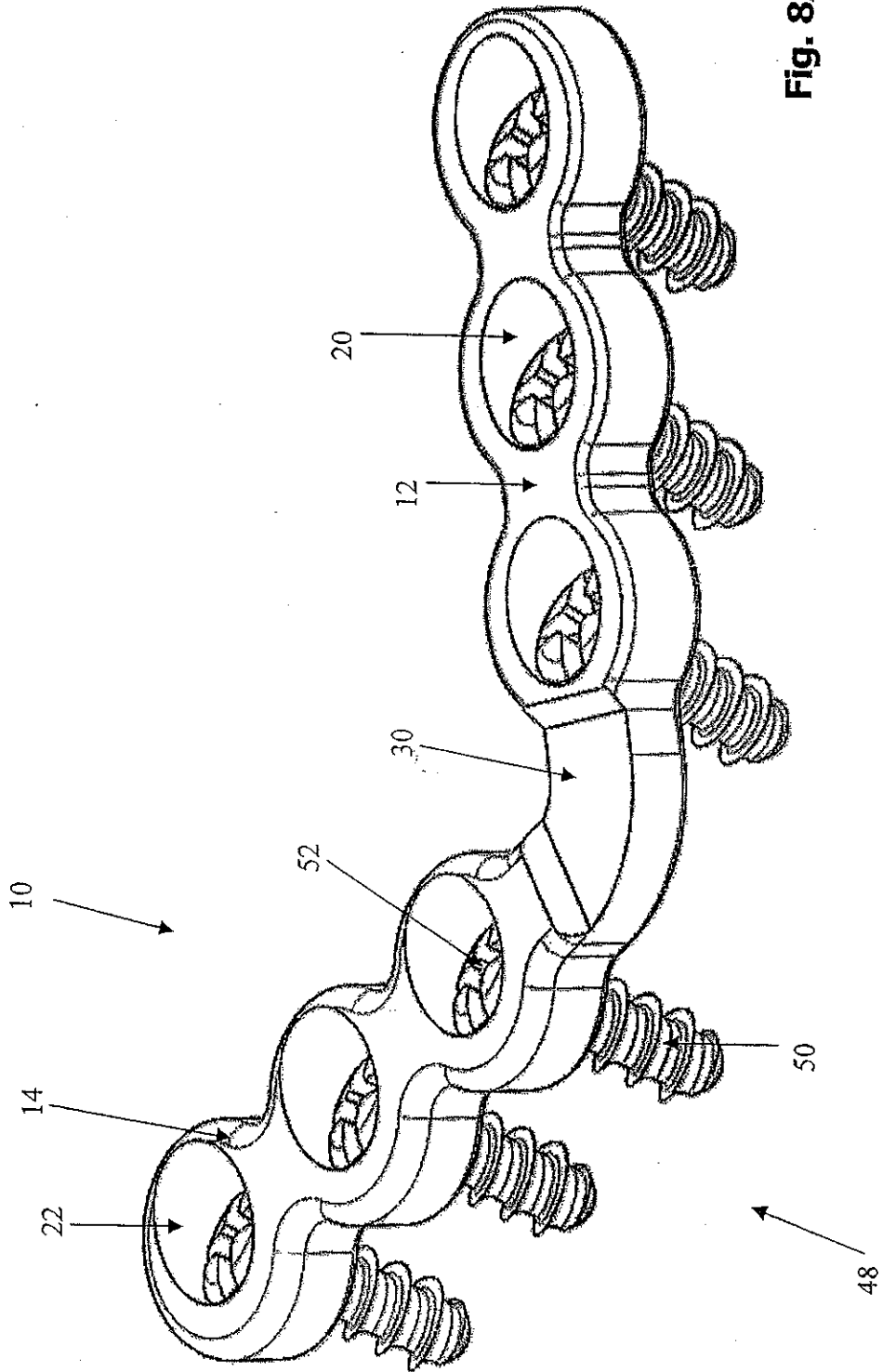

Fig. 8A

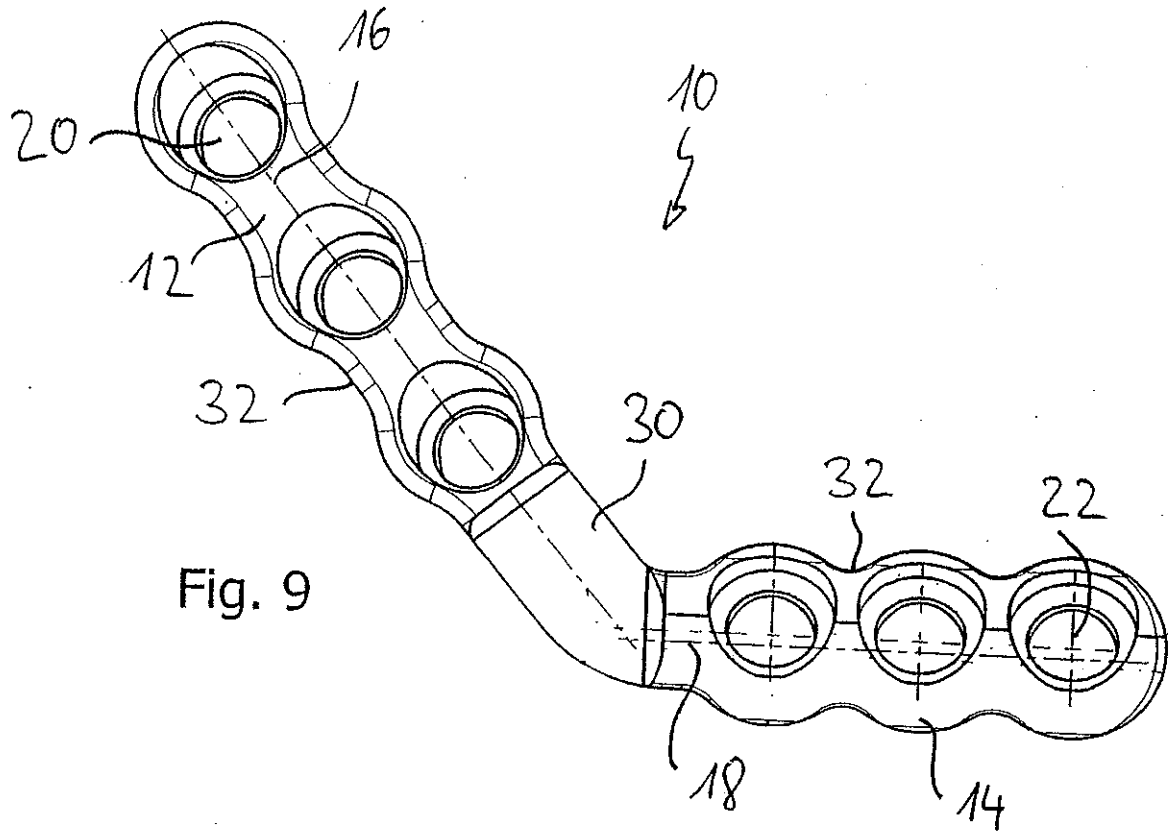

Fig. 9

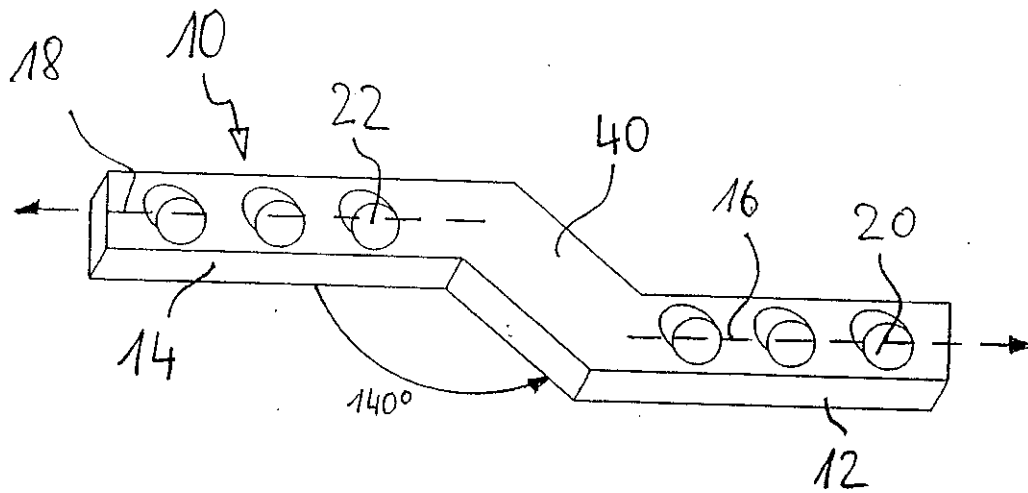
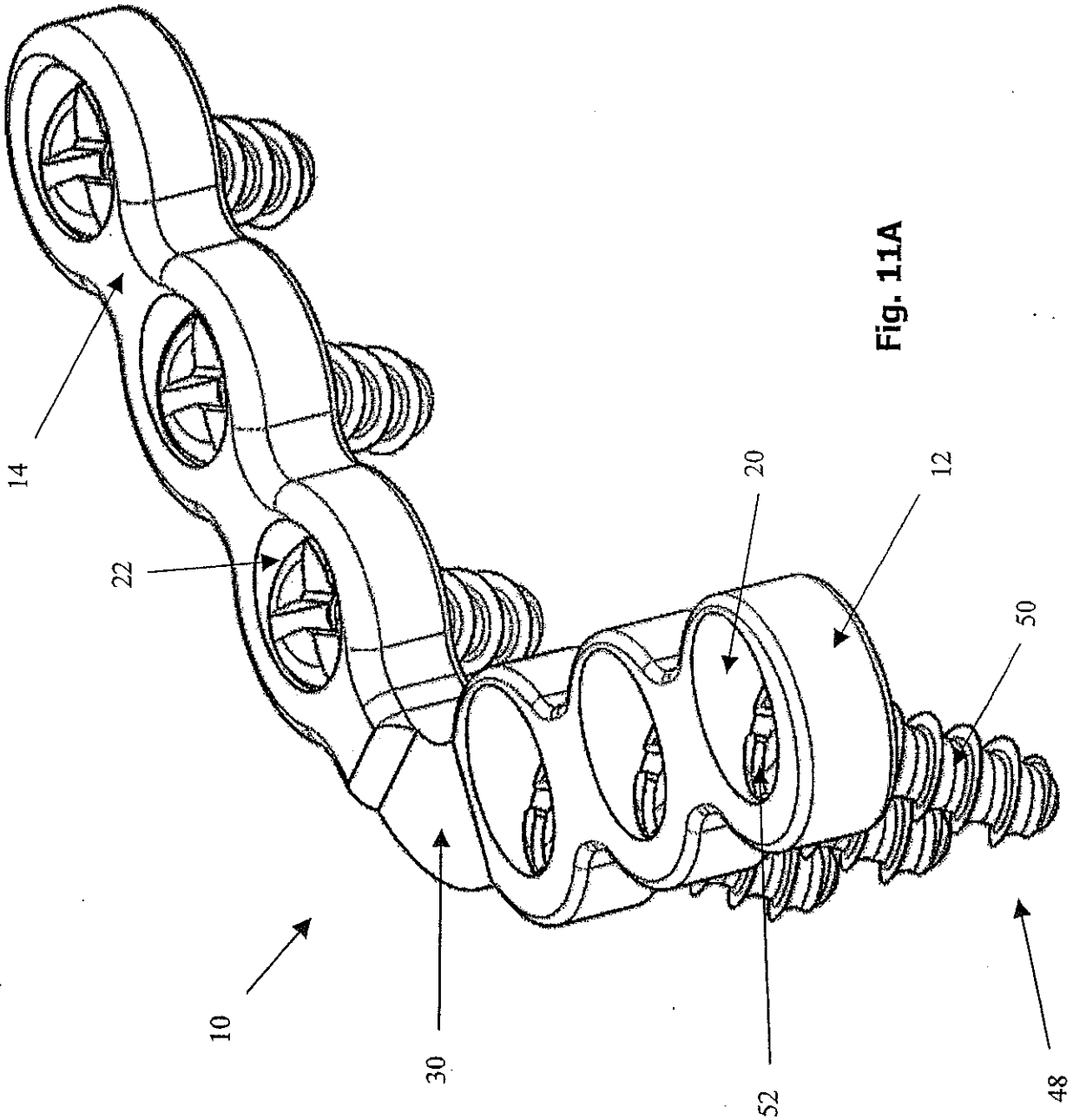

Fig. 10



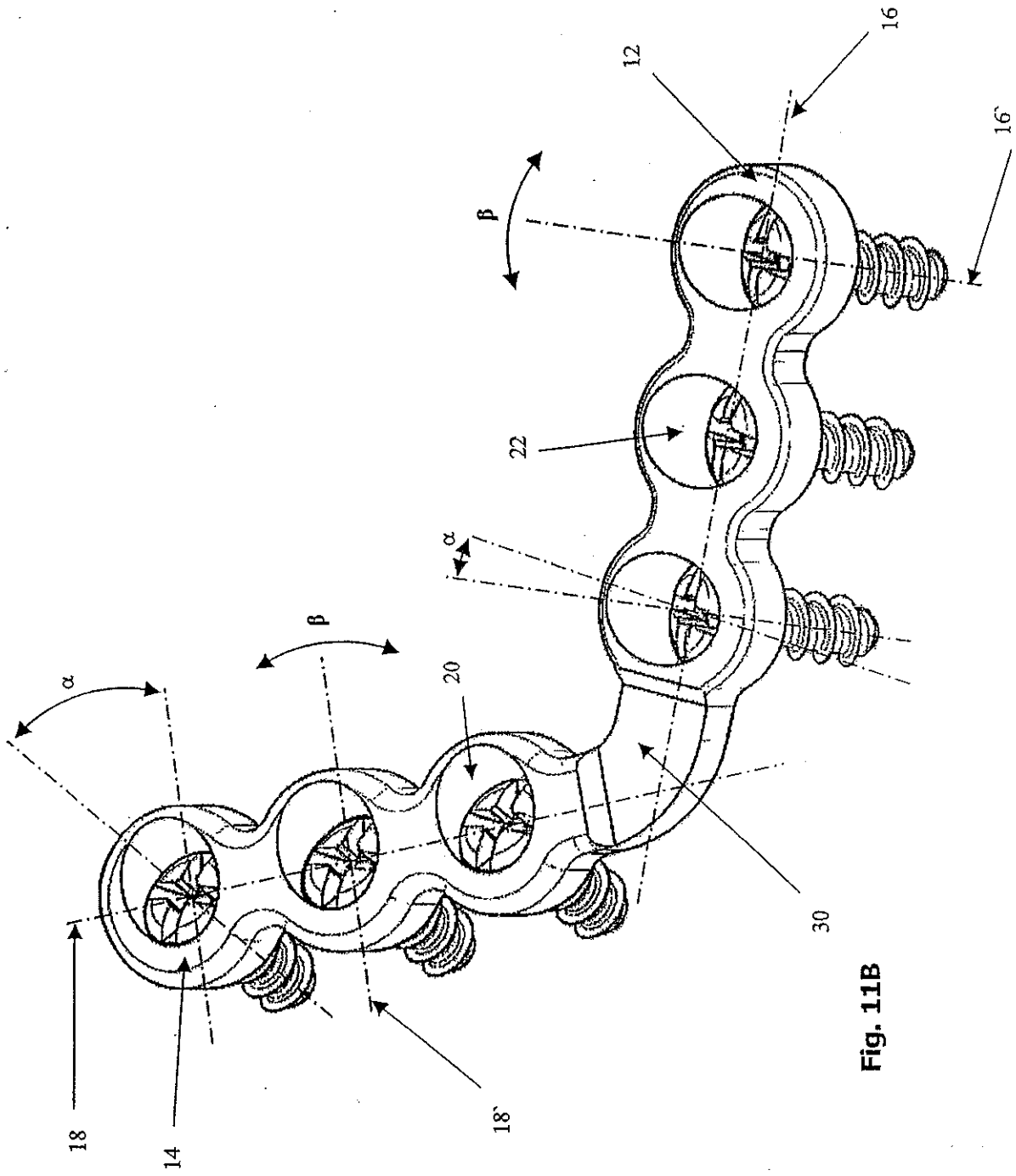

Fig. 11B

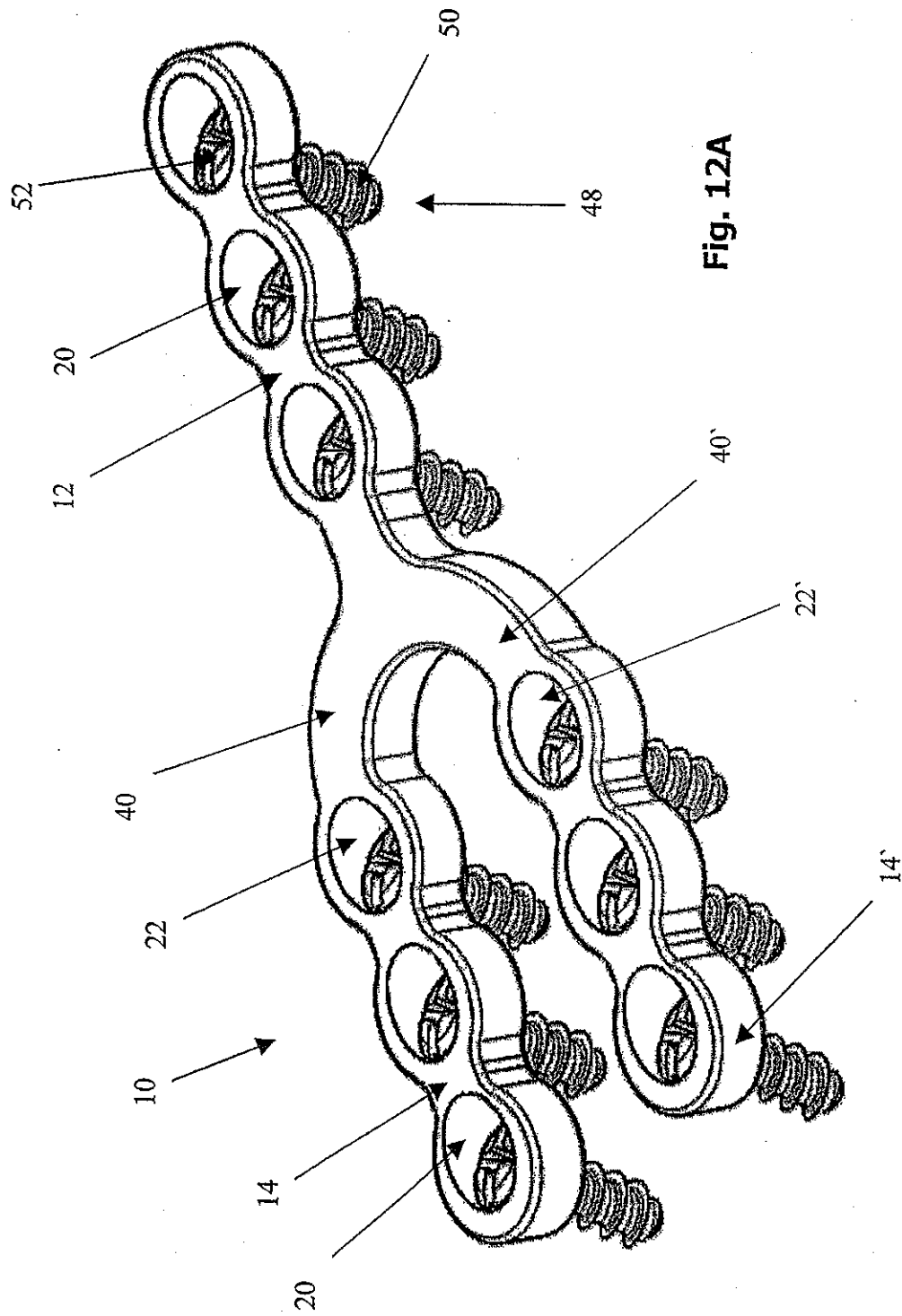

Fig. 12A

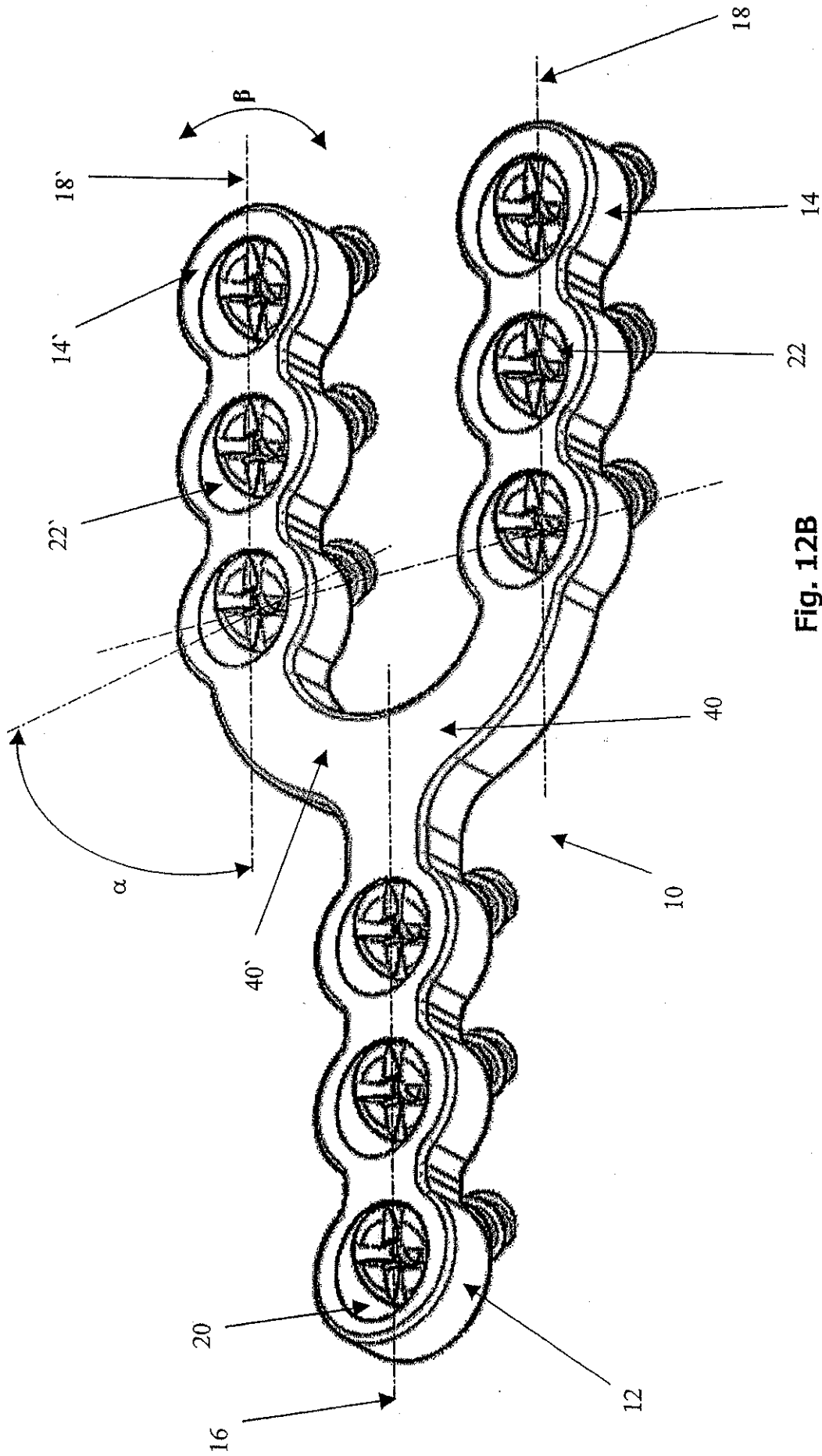

Fig. 12B

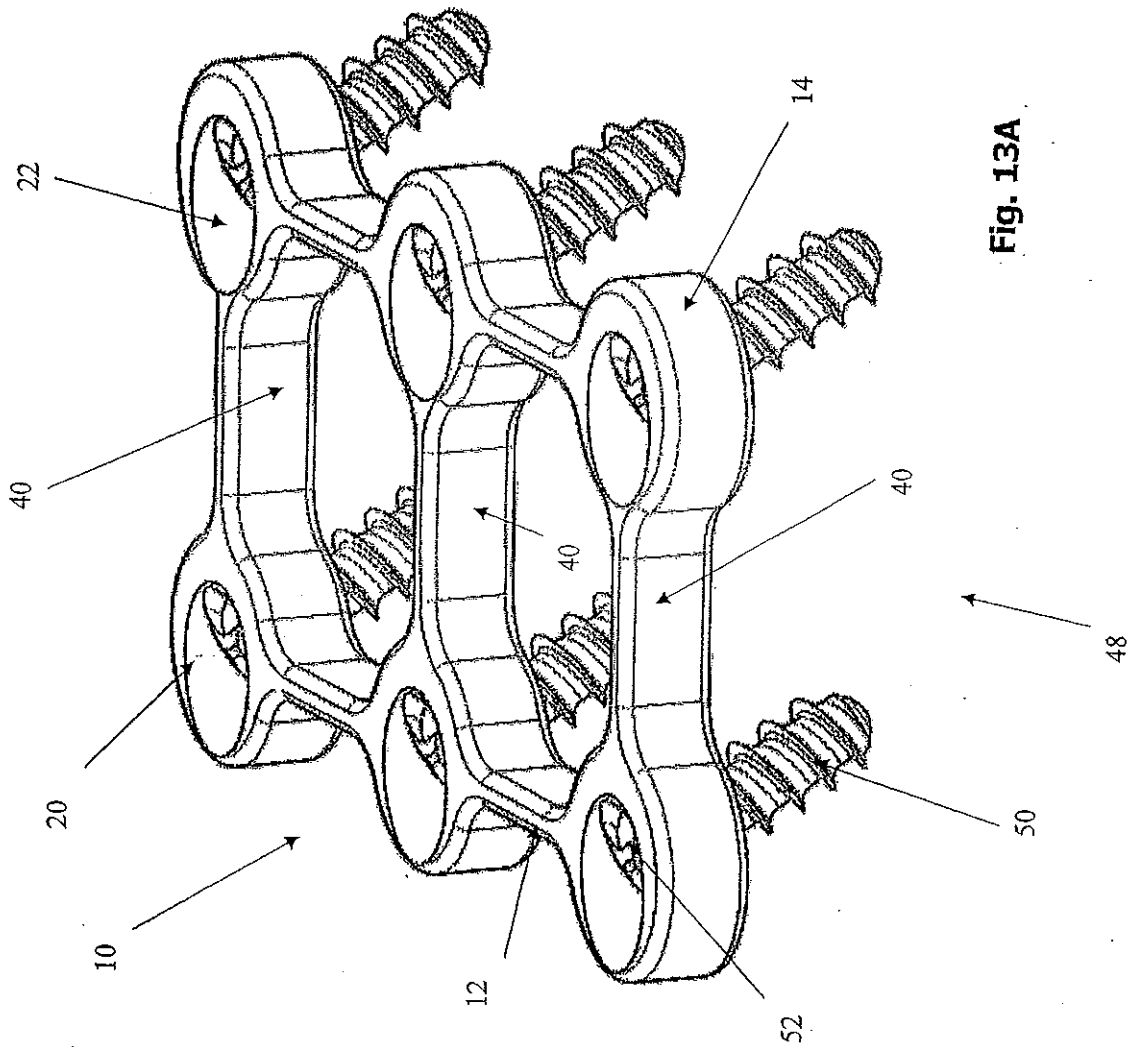

Fig. 13A

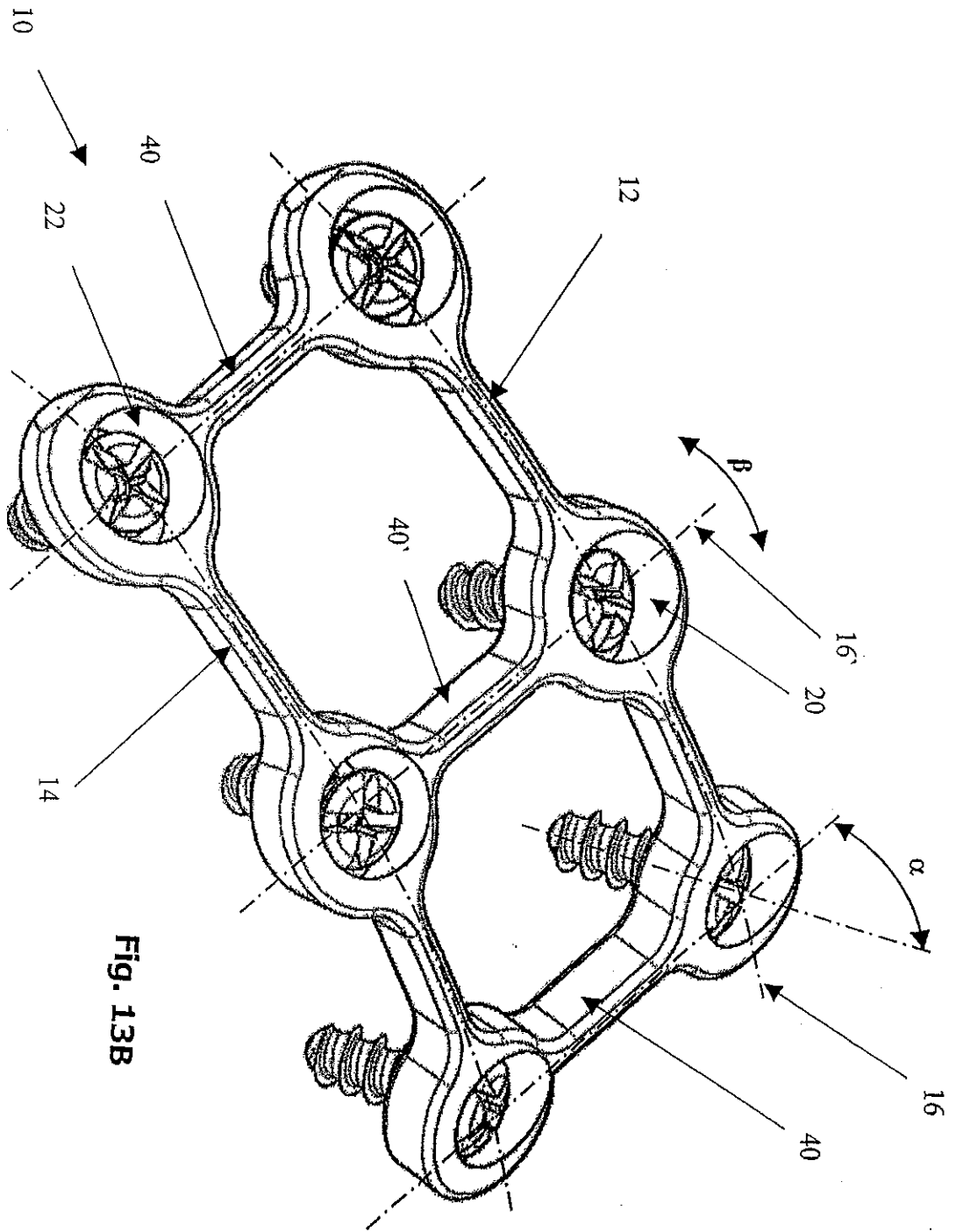

Fig. 13B

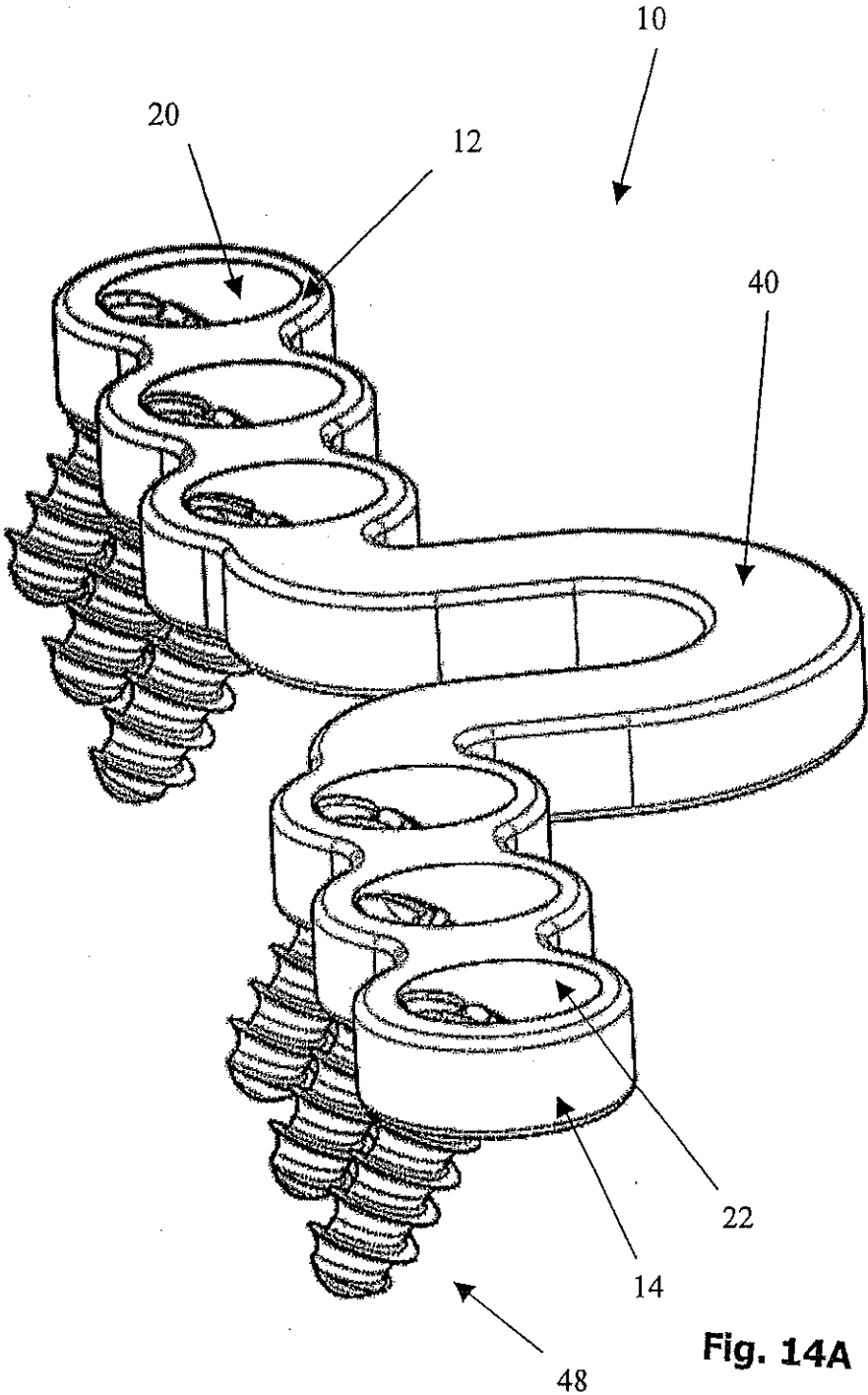

Fig. 14A

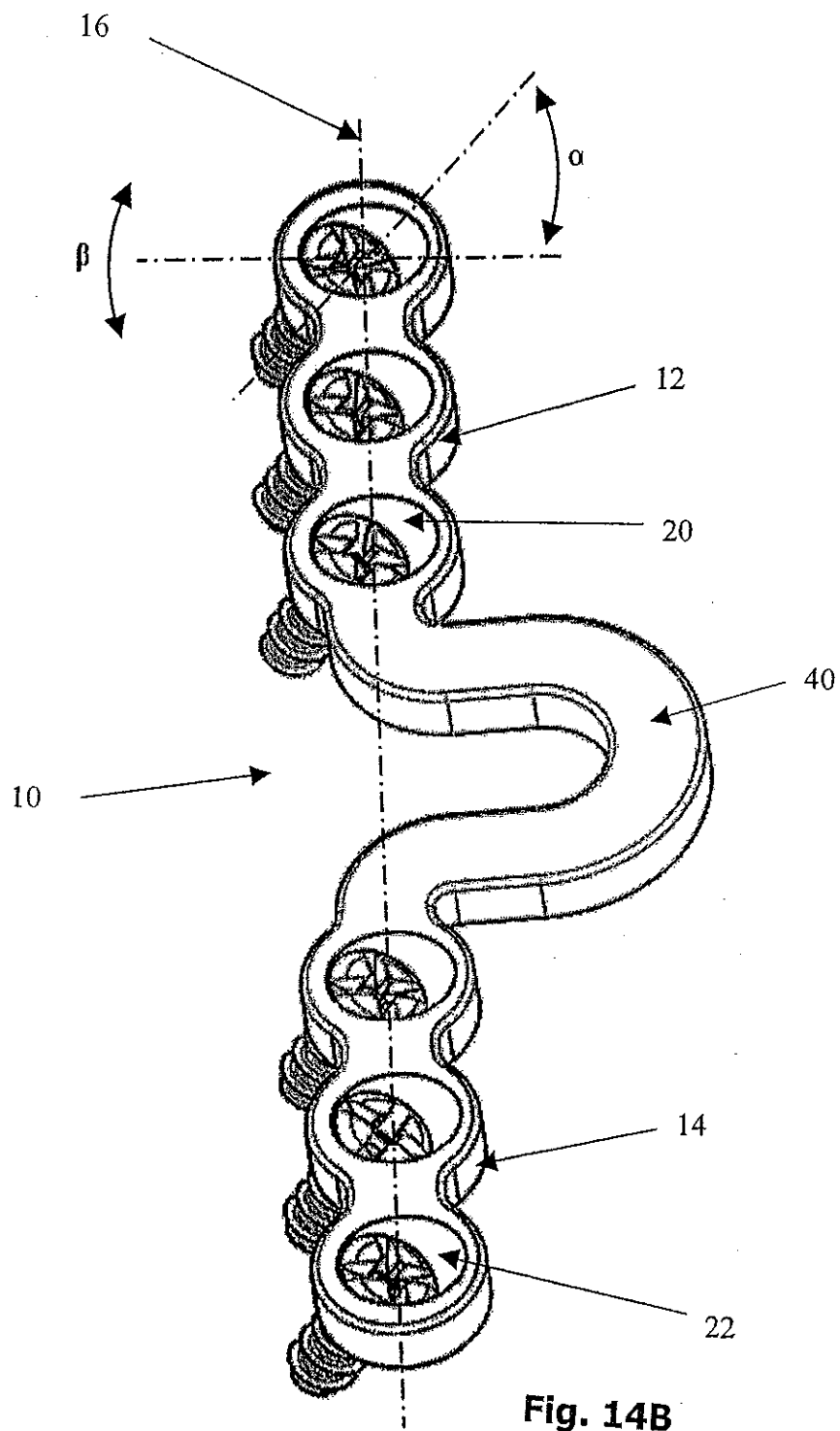

Fig. 14B

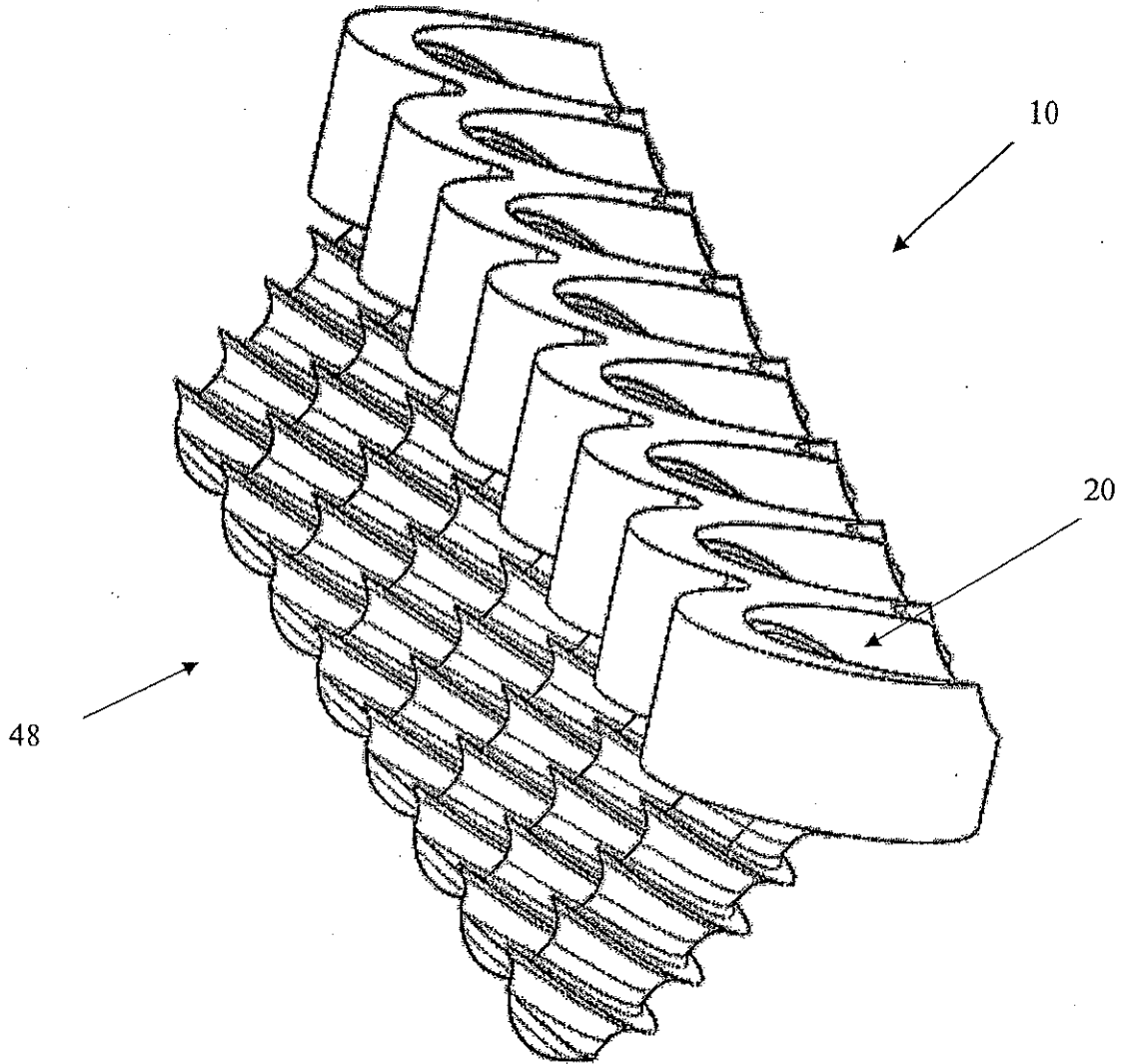

Fig. 15A

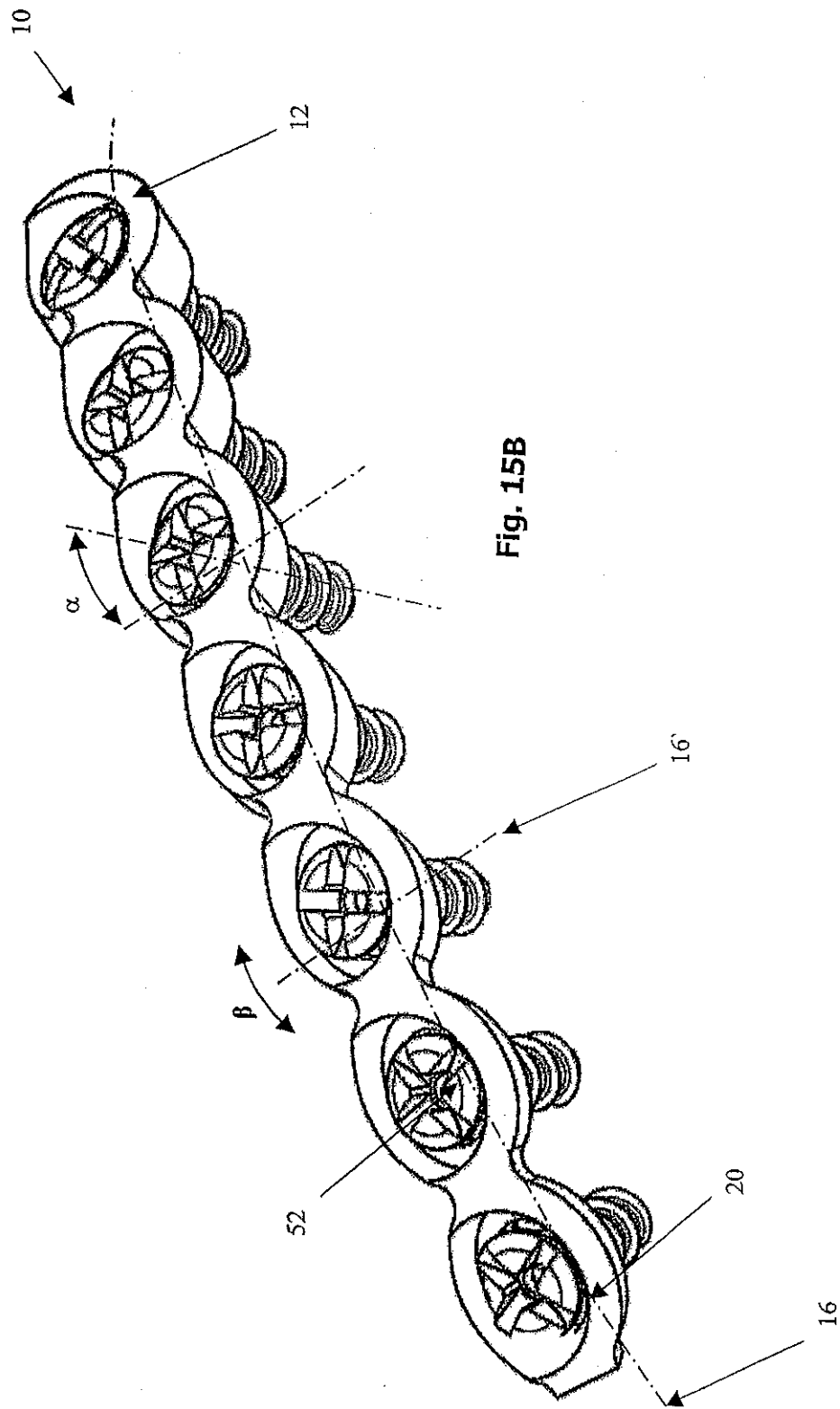
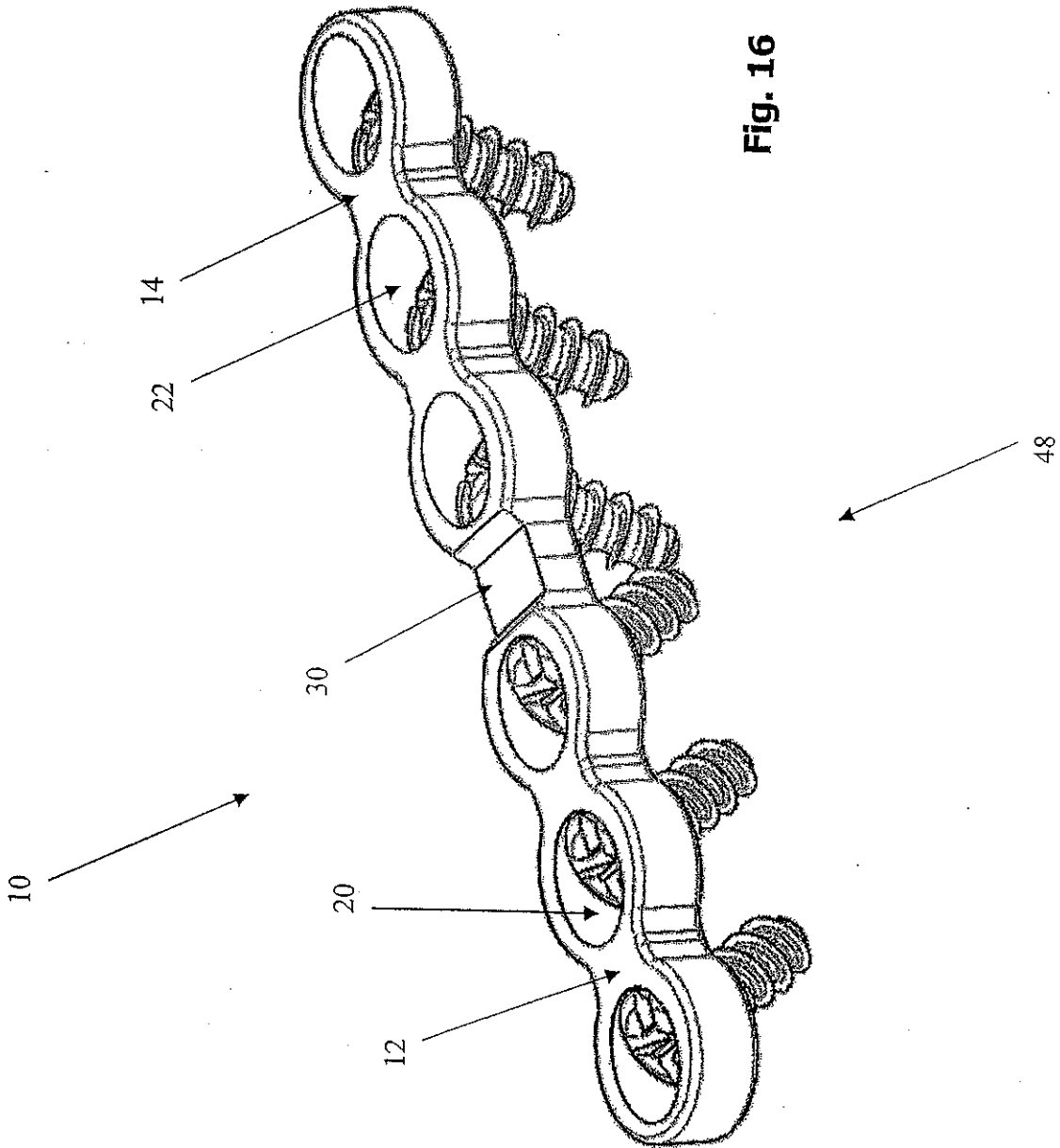

Fig. 15B



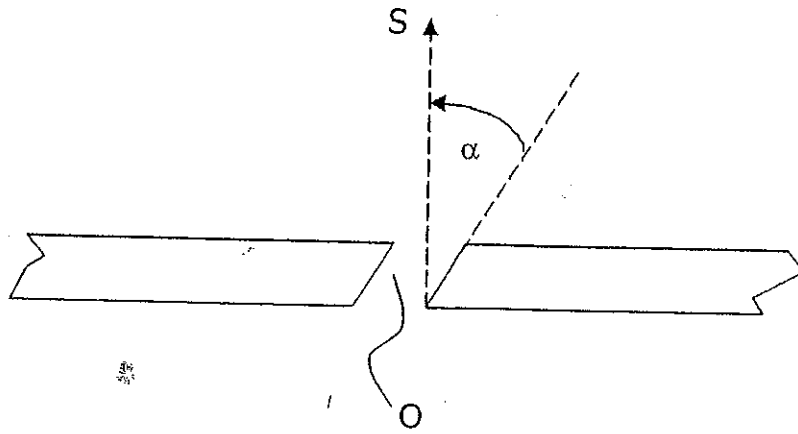

Fig. 17

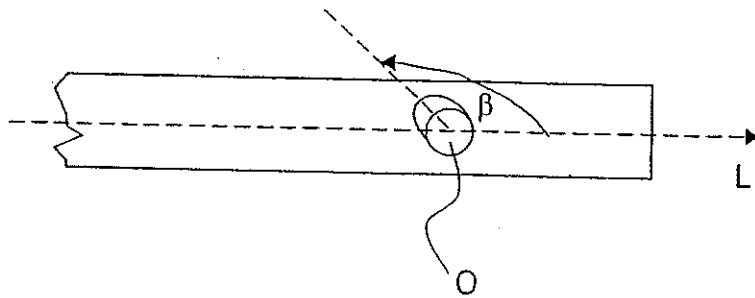

Fig. 18

**Amended claims under Art. 34 PCT**

- 5 1. Osteosynthesis plate (10), in particular for treating jaw fractures, with
- a plane of the plate;
 - a linear first section (12) with a first longitudinal axis (16) and extending substantially within the plane of the plate;
 - a linear second section (14) with a second longitudinal axis (18) and extending substantially within the plane of the plate and inclined to the first section (12);
 - at least one circular first through opening (20) in the first section (12), which is inclined to the plane of the plate and has with respect to the first longitudinal axis (16) a first angular orientation within the plane of the plate; and
 - at least one circular second through opening (22) in the second section (14), which is inclined to the plane of the plate and has with respect to the first longitudinal axis (16) of the first section (12) a second angular orientation within the plane of the plate, wherein the first and the second angular orientations differ with respect to the first longitudinal axis (16) from one another by less than about 60° , so that fastening elements (48) can be introduced into the through openings (20, 22) of both plate sections (12, 14) in a direction predetermined by a single access.
- 10
- 15
- 20
- 25 2. Osteosynthesis plate according to claim 1, characterised in that the first and the second angular orientations differ with respect to the first longitudinal axis (16) from one another by less than about 45° .
- 30 3. Osteosynthesis plate according to claim 1 or 2, characterised in that the first angular orientation is inclined to the first longitudinal axis (16) and/or the second angular orientation is inclined to the second longitudinal axis (18).
- 35 4. Osteosynthesis plate according to one of claims 1 to 3, characterised in that the at least one first through opening (20) intersects the plane of the plate at an angle of approximately 20° to 80° .



5. Osteosynthesis plate according to one of claims 1 to 4, characterised in that the at least one second through opening (22) intersects the plane of the plate at an angle of approximately 20° to 80° .
- 5 6. Osteosynthesis plate according to one of claims 1 to 5, characterised in that the first angular orientation with respect to the first longitudinal axis (16) is between approximately $+90^{\circ}$ and -90° .
- 10 7. Osteosynthesis plate according to one of claims 1 to 6, characterised in that the second angular orientation with respect to the second longitudinal axis (18) is between approximately 60° and 180° .
- 15 8. Osteosynthesis plate according to one of claims 1 to 7, characterised in that the second angular orientation with respect to the second longitudinal axis (18) is between approximately 180° and 300° .
9. Osteosynthesis plate according to one of claims 1 to 8, characterised in that the first section (12) and the second section (14) directly adjoin one another.
- 20 10. Osteosynthesis plate according to one of claims 1 to 9, characterised in that the first section (12) has an angle of approximately 90° to 160° with respect to the second section (14).
- 25 11. Osteosynthesis plate according to one of claims 1 to 10, characterised in that the osteosynthesis plate (10) comprises at least one bending region (30, 32, 40) of reduced plate thickness and/or of reduced plate width and/or of meandering shape.
- 30 12. Osteosynthesis plate according to one of claims 1 to 11, characterised in that the first section (12) has a length between approximately 5 and 70 mm and/or the second section (14) has a length between approximately 5 and 70 mm.
- 35 13. Osteosynthesis plate according to one of claims 1 to 12, characterised in that the osteosynthesis plate (10) in the region of the first section (12) and/or in the region of the second section (14) has a maximum plate thickness between approximately 0.5 and 3.5 mm.



- 5
- 10
14. Osteosynthesis plate according to one of claims 1 to 13, characterised in that the at least one first through opening (20) and/or the at least one second through opening (22) has underneath a plate surface (28) a stop means (26) for a head of a fastening element.
 15. Osteosynthesis plate according to one of claims 1 to 14, characterised in that a plurality of first through openings (20) and/or a plurality of second through openings (22) are provided.