

ANNEXURE 1: REFERENCES

1. Haug, R.H., Barber, J.E. and Reifeis, R. A comparison of mandibular angle fracture plating techniques. *Oral Surg Oral Med Oral Pathol Oral Radio Endod* 1996[82]257-263.
2. Haug, R.H., Nuveen, F.J., Barber, J.E. and Storoe, W. An *in vitro* evaluation of distractors used for osteogenesis. *Oral Surg Oral Med Oral Pathol Oral Radio Endod* 1998[86]648-659.
3. Champy, M., Loddé, J.P., Schmitt, R., Jaeger, J.H. and Muster, D. Mandibular osteosynthesis by miniature screwed plates via a buccal approach. *J Maxillofac Surg* 1978[6]14-21.
4. Michelet, F.X., Deymes, J. and Dessus, B. Osteosynthesis with miniaturized screw plates in maxillofacial surgery. *J Maxillofac Surg* 1973[1]79-84.
5. Dichard, A. and Klotch, D.W. Testing biomechanical strength of repairs for the mandibular angle fracture. *Laryng* 1994[104]201-208.
6. Schierle, H.P., Schmelzeisen, R. and Rahn, B. Experimentelle Untersuchungen zur biomechanischen Stabilität unterschiedlicher Miniplattenkonfigurationen am Kieferwinkel. *Fortschr Kiefer Gesichtschir* 1996[41]166-170.
7. Vollmer, D., Meyer, U., Vegh, A. and Piffko J. Experimental and finite element study of a human mandible. *J Cranio-Maxillofac Surg* 2000[28]91-96.
8. Tate, G.S, Ellis E. and Throckmorton, G.S. Bite forces in patients treated for mandibular angle fractures. *J Oral Maxillofac Surg* 1994[52]734-736.
9. Ellis, E. Throckmorton, G.S. and Sinn, D.P. Bite forces before and after surgical correction of mandibular prognathism. *J Oral Maxillofac Surg* 1996[54]176-181.
10. Throckmorton, G.S., Buschang, P.H. and Ellis, III, E. Improvement of maximum occlusal forces after orthognatic surgery. *J Oral Maxillofac Surg* 1996[54]1080-1086.
11. Harada, K., Watanabe, M., Ohkura, K. and Enomoto, S. Measure of bite force and occlusal contact area before and after bilateral sagittal split ramus osteotomy of the mandible using a new pressure-sensitive device. A preliminary report. *J Oral Maxillofac Surg* 2000[58]370-373.
12. Shetty, V., McBrearty, D, Fourney, M. Caputo, A.A., Champy, M. and Kahn, J.L. Fracture line stability as a function of the internal fixation system: An *in vitro* comparison using a mandibular angle fracture model. *J Oral Maxillofac Surg* 1995[53]791-802.
13. Bütow, K.-W. Titanium-titanium nitride temporomandibular joint prosthesis: Clinical application and 5-year assessment. *J Cranio Max-Fac Surg* 1998[26](Suppl.1)25.

14. Kroon, F.H.M., Mathisson, M., Cordy, J.R. and Rahn, B.A. The use of miniplates in mandibular fractures – an *in vitro* study. *J Cranio-Maxillofac Surg* 1991[19]199-204.
15. Barry, C.P. and Kearns, G.J. Superior border plating technique in the management of isolated mandibular angle fractures: A retrospective study of 50 consecutive patients. *J Maxillofac Surg* 2007[65]1544-1549.
16. Scurry, Jr., W.C., Beus, K.S., Mc Ginn, J. and Fedok, F.G. Operative time analysis of miniplate fixation of the mandible. *Fac Pl Surg* 2005[21]176-179.
17. Ellis, E., Waler, L. and Shafer, D. Treatment of mandibular angle fractures using two noncompression miniplates. *J Oral Maxillofac Surg* 1994[52]1032-1037.
18. Ellis, E. Treatment methods for fractures of the mandibular angle. *J Cr-Maxillofac Tr* 1997[2]28-36.
19. Siddiqui, A., Markose, G., Moos, K.F., McMahon, J. and Ayoub, A.F. One miniplate versus two in the management of mandibular angle fractures: A prospective randomised study. *Brit J Oral Max Fac Surg* 2007[45]223-225.
20. Schierle, H.P., Schmelzeisen, R., Rahn, B. and Pytlik, C. One- or two-plate fixation of mandibular angle fractures. *J Cranio-maxillofac Surg* 1997[25]162-168.
21. Gerlach, K.L. and Schwarz, A. Bite forces in patients after treatment of mandibular angle fractures with miniplate osteosynthesis according to Champy. *Int J Oral Max Fac Surg* 2002[31]345-348.
22. Gerlach, K.L. and Schwarz, A. Load resistance of mandibular angle fractures treated with a miniplate osteosynthesis. *Mund-Kiefer-Heilkunde* 2003[7]241-245.
23. Schlicke, L.H., Penjabi, M.M. and White, A.A. Optimal orientation of transfixation screws across oblique fracture lines. *Cl Orthop* 1979[143]271-277.
24. Krenkel, C. Axial “anchor” screw (lag screw with biconcave washer) or “slanted-screw” plate for osteosynthesis of fractures of the mandibular condylar process. *J Maxillofac Surg* 1992[20]348-353.
25. Meyer, C., Zink, S., Chatalane, B. And Wilk, A clinical experience with osteosynthesis of subcondylar fractures of the mandible using TCP plates. *J Cranio-Maxillofac Surg* 2008[36] ; 260-268.
26. Jacobs, F.J. and Botha, S.J. The minimal invasive mono-cortical angle system, MIMAS. *Int J Oral Maxillo-Fac Surg* 2003[32][Suppl 1 & 2].
27. Smith, B.R., Rachel, J.L., Waite, D.E. and Read, L. Mandibular anatomy as it relates to rigid fixation of the sagittal split ramus osteotomy. *J Oral Maxillofac Surg* 1991[49]222-226.

28. Heibel, H., Alt, K.W., Wächter, R. and Bähr, W. Cortical thickness of the mandible with special reference to miniplate osteosynthesis, Morphometric analysis of autopsy material. *Mund-, Kiefer- und Gesichtschir* 2001[5](3)180-185.
29. Toma, V.S., Mathog, R.H., Toma, R.S. and Meleca, R.J. Transoral versus extraoral reduction of mandible fractures: A comparison of complication rates and other factors. *Otolaryng Head and Neck Surg* 2003[128]215-219.
30. Guimond, C., Johnson, J.V. and Marchena, J.M. Fixation of mandibular angle fractures with a 2.0mm 3-dimensional curved angle strut plate. *J Oral Maxillofac Surg* 2005[63]209-214.
31. Uckan, S., Schwimmer, A., Kummer, F. and Greenberg, A.M. Effect of the angle of the screw on the stability of the mandibular sagittal split ramus osteotomy: A study in sheep mandibles. *Brit J Oral Maxillo-Fac Surg* 2001[39]266-269.
32. Jacobs, F.J. and Botha, S.J. 2004 Minimal-Invasive-Monocortical Angle system-load sharing load bearing forces. *J Dent Res* 83 (Special Issue B).
33. Haug, R. H., Fattahi, T.T. and Goltz M. A biomechanical evaluation of mandibular angle fracture plating techniques. *J Oral Maxillo-Fac Surg* 2001[59]1199-1210.
34. Feller, K.-U., Richter, G., Schneider, M. and Eckelt, U. Combination of microplate and mini-plate for osteosynthesis of mandibular fractures: An experimental study. *Int Oral Maxillo-Fac Surg* 2002[31] 78-83.
35. Krenkel, C. Biomechanics and osteosynthesis of condylar neck fractures of the mandible. Berlin: Quintessence; 1994; 57+151-152.
36. Zwang-Wei, W.U., Ya-Dong, Y.U., Zi-Ying, Qi-Lin, L.I.U. and Li-Ming, Y.U. Finite element analysis for tension band fixation of mandibular fractures. *J Jilin Uni (Med Ed)* 2006[32] (5)862-865.
37. Jacobs, F.J. and Botha, S.J. 2006 Minimal Invasive Mono-Cortical Angle System – Multiple Angle Application. *J Dent Res* 83 (Special Issue B).
38. Nissenbaum, M., Lownie, M. and Cleaton Jones, P. Relative displacement resistance of standard and low-profile bone plates in experimental mandibular angle fractures. *Oral Surg Oral Med Oral Path* 1997[83]427-432.
39. Arshad S., Markose, G. and Khursheed, F.M. One miniplate versus two in the management of mandibular angle fractures : A prospective randomised study. *J Oral Maxillo-Fac Surg* 2007[45]:223-225.
40. Farmand, M. and Dupoirieux, L. The value of 3-dimensional plates in maxillofacial surgery. *Rev Stomatol Chir Maxillofac* 1992 [93]353-357.
41. Meyer, C., Kahn, J.L., Boutemi, P. and Wilk, A. Photo elastic analysis of bone deformation in the region of mandibular Condyle during mastication. *J Cranio Maxillo-Fac Surg* 2002[30]160-169.
42. Meyer, C. Experimental evaluation of three osteosynthesis devices used for stabilizing condylar fractures of the mandible. *J Cranio-Max Fac Surg* 2006[34]173-181.
43. Rowe, N.I. and Williams, J.L. Maxillofacial Injuries. Edinburg London: Churchill Livingstone;1985; p10.



UNIVERSITEIT VAN PRETORIA
UNIVERSITY OF PRETORIA
YUNIBESITHI YA PRETORIA

Addendum 1: Pilot Study Proposal



UNIVERSITEIT VAN PRETORIA
UNIVERSITY OF PRETORIA
YUNIBESITHI YA PRETORIA



Centre for Integrated Sensing Systems

PROJECT PROPOSAL

ISP(2002)IC036

**Pilot Study on Mono-cortical Systems
used in Mandible Fractures**

Prepared for: Professor F.J. Jacobs
P.O. Box 915-1029
Faerie Glen
0043

Prepared by: C. Mc Duling
Manufacturing and Materials Technology, CSIR
P. O. Box 395
Pretoria
0001



DOCUMENT CONTROL

Degree of Confidentiality	:	Company Confidential
Title	:	Pilot Study on Mono-cortical System for Mandible Fractures
Author(s)	:	C. McDuling
Date of Issue	:	1 July 2002
Number of Pages	:	11
Issuing Organisation: Centre for Integrated Sensing Systems Sensing & Actuation PO Box 395 0001 Pretoria	Tel.:	(27 12) 841-2556
	Fax :	(27 12) 841-4038
CONTRACT NAME	:	Pilot Study on Mono-cortical System
PROJECT NUMBER	:	HAB04
KEYWORDS	:	Mono-cortical System Mandible Fractures
ISSUE NUMBER	:	1
COPY NUMBER	:	1, 2, 3
PREPARED BY	:	Chris McDuling
REVIEWED BY	:	D. Lindeque
Responsibility	Name	Signature
Project Leader	C. McDuling	
Business Area Manager	D. Lindeque	
Quality Management	A. Chaffey	
DISTRIBUTION		
Name	Designation	Copy Number
I&C Registry	Bld. 14 / E40	1 (Master Copy)
Prof. F.J. Jacobs	Faerie Glen	2
C. McDuling	Bld 14 / F	3



INDEX

EXECUTIVE SUMMARY	4
1. INTRODUCTION	5
2. APPROACH	5
3. OBJECTIVES	5
4. DETAILED SCOPE OF WORK	5
5. EXCLUSIONS	6
6. DELIVERABLES	6
7. COSTS	6
8. PAYMENT AND DELIVERY SCHEDULE	6
9. PROPOSAL VALIDITY	6
10. CSIR TEAM	6
11. PROPOSAL ACCEPTANCE	7
12. CSIR, DIVISION OF MANUFACTURING AND MATERIALS BANK ACCOUNT INFORMATION	7
13. CONTRACT CONDITIONS	7
APPENDIX 1 : ACCEPTANCE SHEET	8
APPENDIX 2 : GENERAL CONTRACT CONDITIONS	9



EXECUTIVE SUMMARY

Professor F.J. Jacobs approached the CSIR in connection with a pilot study on Mono-cortical Systems for mandible fractures. The approach would be to use two fixation methods on proximal segments of mandibles from sheep and to do mechanical tests in order to differentiate the strength of the two fixations. Each mandible will be divided in the anterior midline between the teeth and embedded in an acrylic resin. The mandible will then be installed in a test jig.

The objective would be to conduct a number of tests in different load applications in order to measure the consistency of each fixation method and to compare the results of the two methods during the same load application.

The load will be applied by means of an Instron universal servo hydraulic testing machine. The displacement of the fractured mandible at the fixation will be measured by means of a clip gauge installed in a transverse direction to the fracture. The load and displacement will be recorded and the results of each mandible with the two different fixations will be compared. A number of tests as required by Professor Jacobs will be conducted to vary the position of load application in order to measure the consistency of each fixation under different load conditions.

A comprehensive test report stating the testing methodology and test results will be issued once all the tests are completed.



1. INTRODUCTION

Professor F. J. Jacobs from MEDUNSA approached the CSIR in connection with a pilot study on Mono-cortical Systems for mandible fractures. Tests will be conducted at the mechanical testing laboratory of the CSIR on a number of sheep mandibles. Two fixation methods will be used in order to measure the difference in strength on the same mandible when subjected to the same loading conditions. The first fixation method consists of a mono-cortical conventional 2mm six-hole miniplate with screws placed at a 90° angle to the bone. The second method consists of a mono-cortical newly designed six-hole plate with screws inserted at an angle of 60° . In order to differentiate the strength of the two fixation methods, each mandible will be prepared with a 60° six-hole plate on the one side and a 90° six-hole plate on the other side of the mandible.

2. APPROACH

A number of sheep mandibles will be obtained by Professor Jacobs and prepared for test applications. A test jig will be manufactured by the CSIR to accommodate the mandible specimens. The fixation of the fractures and the embedding of the mandibles will be carried out by Professor Jacobs. The tests will be carried out in an Instron universal servo hydraulic testing machine and the load will be applied at a constant displacement rate. The displacement of the mandible at the fixation will be measured by means of a clip gauge attached to the mandible. The load and displacement will be recorded and the results of each mandible with the two different fixations will be compared.

3. OBJECTIVES

The objective would be to conduct a number of tests in different load applications in order to measure the consistency of each fixation method and to compare the results of the two methods during the same load application.

4. DETAILED SCOPE OF WORK

4.1 Specimen Preparation

4.1.1 The test specimens will be prepared and delivered to the CSIR test facility by Professor Jacobs.

4.1.2 Modifications to accommodate the test specimens in the test jig will be made at the testing laboratory once the first sample is delivered.

4.2 Test Criteria

The number of tests will be determined by the consistency of the test results and the variation of the position where the load is applied.



5. EXCLUSIONS

- 5.1 The CSIR takes no responsibility for the applicability of the test conditions to real life operating characteristics of the product.
- 5.2 The CSIR cannot be held responsible for any failure or consequential damage resulting from such failure.

6. DELIVERABLES

A final test report will be compiled after completion of the last test.

7. COSTS

- 7.1 Manufacturing of Test Jig: R2200-00
- 7.2 Testing:
- a) Set-up & preparations per test series: R350-00
 - b) Testing per load application: R475-00
- 7.3 Test Report: R500-00

8. PAYMENT AND DELIVERY SCHEDULE

Payment covering the total cost will be 30 days after invoice and VAT is not included in the above quoted costs.

Delivery of the final test report will be made ten working days after last test.

9. PROPOSAL VALIDITY

This proposal is valid for 30 days, after which time it will be subject to review.

10. CSIR TEAM

Your contact persons at CSIR Manufacturing and Materials Division are:

Chris Mc Duling	Project Leader	(012) 841-4226
Dirk Lindeque	Business Area Manager	(012) 841-4436
Werner Merbold	Centre Manager	(012) 841-2696



11. PROPOSAL ACCEPTANCE

To accept this proposal, please sign the Acceptance Sheet, and fax it to Manufacturing & Materials, CSIR together with your order.

12. CSIR, DIVISION OF MANUFACTURING AND MATERIALS BANK ACCOUNT INFORMATION

Branch: ABSA Bank Lynnwood, P O Box 35504
Account No.: 540002304
Branch Code: 33474510

13. CONTRACT CONDITIONS

The attached CSIR General Conditions, Appendix 2, applies to the work to be carried out under this quotation. Acceptance of the quotation implies acceptance of the conditions.



UNIVERSITEIT VAN PRETORIA
UNIVERSITY OF PRETORIA
YUNIBESITHI YA PRETORIA

Addendum 2: Research Protocol



UNIVERSITEIT VAN PRETORIA
UNIVERSITY OF PRETORIA
YUNIBESITHI YA PRETORIA

University of Pretoria



Research Protocol

Name: Prof. Frederick J Jacobs

Address: 313 Vista Drive
Fairie Glen
Pretoria
0043

Department: Maxillo-Facial Oral and Surgery

Proposed Degree: Protocol/Thesis to be submitted in fulfilment of the requirements for the degree of PhD

Title of Thesis: The effect of innovative screw angled mini-plates on biomechanical stability of mono-cortical fixation-an in vitro model

Promotor: Prof Kurt-W Bütow
Head, Department of Maxillo-Facial Oral and Surgery

Examiners:
Internal: Prof Kurt-W Bütow
Department of Maxillo-Facial Oral and Surgery
Faculty of Health Sciences
School of Dentistry
University of Pretoria

Date: 16th May 2005

1. THESIS TITLE

The effect of innovative screw angled mini-plates on biomechanical stability of mono-cortical fixation- an in vitro model.

2. PURPOSE

The purpose of this study is to introduce a testing device and a less complex scientifically relevant method of investigating the biomechanical behaviour of mono-cortical mandibular fragment fixation at different screw angles.

3. AIM

The aim of this investigation is:

- The development and fabrication of a testing device to evaluate 3-dimensional “in vitro” stability of mini-plate fixation of the mandible which emulates clinical relevance.
- To determine and quantify the efficacy of biomechanical stability of mono-cortical fixation employing mini-plates designed to accommodate a screw-placement angle of 90° (control) and design innovations featuring screw-placement angles of 45°, 60° and 75° respectively. These fixation displacement characteristics will be assessed in tension, compression and torque modes of loading.
- To compare and reflect significant differences in the flexural data obtained from the various fixation systems.

4. BACKGROUND

Mini-plate fixation of displaced fractures was advocated by Roberts in 1964.¹ During the ensuing decades, mini-plate fixation techniques, without intermaxillary fixation, evolved as a consequence of the delineation of the intrinsic anatomy and biomechanical principles associated with deformation of the mandible in function.^{2,3}

The development and construction of the 3-dimensional testing device should simplify technically challenging procedures presently employed for accurate assessment of biomechanical stability of mandibular fixation systems.

The efficacy of biomechanical stability of mono-cortical fixation, when subjected to tensile, compressive and torsional modes of loading, should exhibit similar load displacement characteristics for both the conventional 90°, as well as the experimental screw plate designs featuring more acute placement angulations.

The innovative design configurations proposed for evaluation, should be clinically relevant.

4.1 ANATOMICAL CONSIDERATIONS

Viable surgical procedures are dependent on a knowledge of the anatomy of the angle of the mandible, including the position of the inferior alveolar neuro-vascular bundle. Furthermore, cortical bone

plate thickness varies in the retromolar area of the mandible, which is important when applying mono-cortical rigid internal plate fixation.

4.1.1 THE NEURO-VASCULAR BUNDLE

Data from anatomical studies indicate that the minimal distance from the inferior aspect of the inferior alveolar canal to the inferior border of the mandible, is approximately 5,0mm (n=4,9). The mean distance at the second molar has been found to be 8,3mm and 8,9mm for the third molar region.⁴

If cortical penetration (cutting) is performed just medially to the external oblique ridge, the vertical distance between the most superior aspect of the canal and the cortex will be 6,9mm in the second molar, 10,9mm in the third molar, and 13,9mm in the most anterior symphysis region of the ramus.⁴

4.1.2 CORTICAL PLATE THICKNESS IN RELATION TO RIGID FIXATION IN THE MANDIBULAR ANGLE

The buccal cortical plate is thicker at the external oblique ridge (mean: 3,0 to 3,5mm) than at 5mm above the inferior border (mean: 2.2 to 2.5mm) by 0,9 to 1,1mm.⁴

4.2 TRANS-BUCCAL/PER-CUTANEOUS SURGICAL APPROACH

A distinct disadvantage of plating in the mandible angle is related to the plate placement on the buccal lateral aspect. This requires a trans-buccal approach (an approach through the cheek, skin, muscle and periosteum) with the use of a trocar in order to be able to place the screws at right angles (90°) to the plates,⁵ as illustrated in Fig. 1.

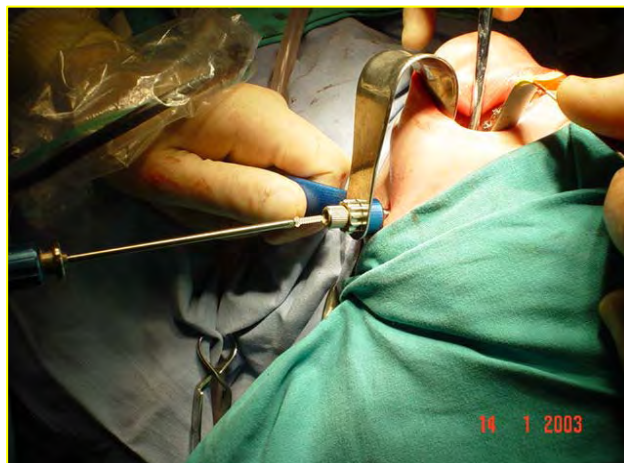

FIGURE 1. Illustration of trans-buccal technique

This in turn results in higher operating cost due to time spent and scarring of the facial skin. This has been estimated to add an additional operating time of 21 minutes (SD 11, median 17,5).⁶

Trans-buccal trocar screw placement is required for plates placed buccally or inferior to the external oblique ridge.⁷ Many studies have shown the possibility of a number of complications.⁸ Per-cutaneous instrumentation can cause a haematoma, false aneurysms, nerve fall-out, longer operating time, skin scarring, and furthermore, complicated extended operation time in removal of such plating systems.

Two-plate fixation is more time-consuming and the trans-buccal use of a trocar, which contributes to extended operation time, resulting in longer exposure time of bone to a higher bacterial contamination. Loss of a screw during the surgical procedure, introduced through the trocar, results again in extended operating time as it might have to be retrieved from a tissue plane.

Per-cutaneous instrumentation is also essential when applying the mono-cortical strut plate system (used to provide increased strength) at the angle of the mandible.⁹

The angle of the mandible, where the majority of fractures are located, demonstrates inferior narrowing and the location of a third molar, as an impaction or un-erupted tooth, has a major impact on stabilization of a fracture. Due to the biomechanics of the mandible, these fractures are associated with the highest incidence of post-surgical complications.¹⁰

4.3 BIOMECHANICAL CONSIDERATIONS

In the past three decades, a variety of studies has contributed to the conceptualization of the biomechanical principles dictating mandibular behaviour during normal function. The two-dimensional models demonstrate tension at the level of the dentition and compression at the lower border of the mandible whereas the 3-dimensional approach includes forces of the musculature on the balancing side during mastication.^{11,12} Based on these principles, different methods of plate fixation have evolved to solve the problem of displaced fracture segments.

Currently, controversy continues unabated about the use of one or two mini-plates in mono-cortical plating for the purpose of providing adequate support and stability to facilitate effective immediate function.

In the conventional plating systems, stability is derived from tightening the screw perpendicular to the mini-plate and adjacent bone. Anatomical constraints limit intra-oral access for bi-planar placement of the plate located on the lateral surface of the external oblique ridge. The difficult anatomical access necessitates compensation by drilling and screw application at an angle other than the required right angle. This practice results in an inevitable acute placement angle of screw, screwdriver and screw to bone interface.

Mechanical engineering theory states that, for identical placement loads, screws inserted perpendicular to the engagement surface,

should provide twenty percent more resistance to displacement than other placement angulations.¹³ However, viewed from a bio-mechanical perspective, bi-cortical engaging screws inserted at an angle smaller than 90° have a longer surface area of interfacial cortical bone contact and this factor may eliminate the theoretical disadvantage of screw placement at 60° angulation to the bone surface.¹⁴ If this principle is applicable, it can be assumed that the 60° and the 90° configurations should exhibit similar biomechanical characteristics.

5. STATEMENT OF THE PROBLEM

The preceding résumé of the literature indicates an awareness of the factors that influence the prognosis of mandibular fracture fixation. In general, these factors are related to three areas:

- (i) Anatomical and surgical constraints
- (ii) Analytical investigations of the biomechanical behaviour of the mandible
- (iii) Biomechanical design and location of the fixation system

While the first area has enjoyed extensive investigation, the second area which has to do with prediction of functional stability, is subject to complicated analytical methodology. The third area, which concerns the design and location of the fixation systems, is extensively but inconclusively reviewed. Very little attention has been given to:

- (i) Development of less complicated methods for delineating the biomechanical behaviour of the mandible for functional stability determination of fracture fixation.
- (ii) Addressing the problem of anatomical positioning of the plating system to ensure a minimal invasive surgical technique and cost effective operating time.
- (iii) The relationship between biomechanical stability and the screw placement angle in mono-cortical fixation.

Since the prognosis of mandibular angle fractures, osteosynthesis segments are dependent on post-operative stability of the displaced segments. There is a need for detailed consideration of the fixation characteristics of acute vector angled screw mini-plate designs.

6. EXPERIMENTAL PROCEDURES

The materials and methods used during this study will be documented in sections which are broadly co-incident with the lines of the investigation followed.

6.1 COMPILATION OF MANDIBLE SAMPLES

A total of 60 polyurethane synthetic mandible replicas (Synbone, Landquart, Switerland) will be used in this study. These synthetic

replica mandibles simulate the human mandible by demonstrating a rigid outer cortex and softer medulla component.

This uniformity allows for more reliable comparison of fixation techniques by eliminating the variability normally seen in cadaveric and sheep mandibles. The specimens will be sectioned in the midline to produce 120 hemi-mandibles for evaluation. These samples will be divided into four categories with 30 specimens in each category. The different fixation categories consist of:

- Mini-plate with 90° screw placement angle
- Mini-plate with 75° screw placement angle
- Mini-plate with 60° screw placement angle
- Mini-plate with 45° screw placement angle

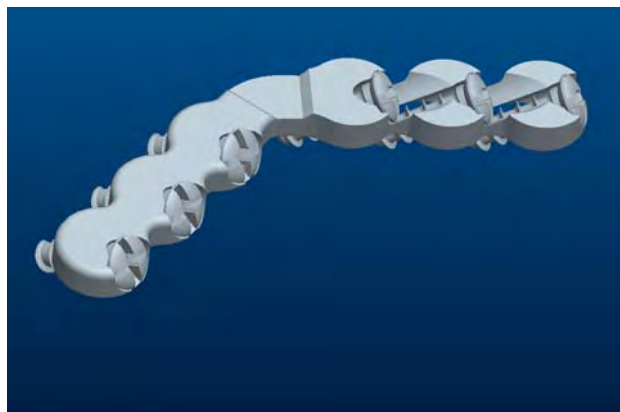

FIGURE 2. Illustration of a design for angled screw placement

These categories will be further subdivided into two different groups, each comprising 15 samples for the 3-dimensional fixation stability evaluation. The modes of loading to determine biomechanical stability, in the developed test jig for each group, are the following:

- Tension and compression evaluation
- Torque evaluation

6.2 FABRICATION OF POSITIONING TEMPLATES

An intact hemi-mandible will be used for the fabrication of the three polymethylmethacrylate (PMMA) localization templates required for standardised and chronological preparation of the test samples and positioning of these samples in the mechanical testing device as follows:

- Rigid fixation template

The purpose of this template is for rigid fixation of the proximal segment of the test module to the vertical fixation plate of the test jig.

Use of the prefabricated PMMA template will standardise and correlate the required receptacle holes through the coronoid/ramus region and the existing receptacle holes in the

vertical fixation plate. Furthermore, the location of these receptacle holes in the mandible, will align the distal section of the test module to the free-rotating crib located on the horizontal rotational axis of the load application wheel to be employed for torque evaluation.

- Mini-plate positioning template

The template for standardised mini-plate localisation on the ventral aspect of the external oblique ridge, is designed to accommodate two different plate positions in close proximity to one another. The upper position will be employed for tension/compression evaluation whereas torque will be derived from the inferiorly located structure. This approach is primarily a cost saving exercise which is unlikely to compromise biomechanical principles. The template will feature profile perforations imprinted to accommodate actual placement of the mini-plates for precise localization and screw access hole preparation. In addition, the screw access holes on the various mini-plates will have drill guides for accurate angular preparation and predetermined depth penetration for the fixation screws.

- Segmentation template

The mini-plate position template will be modified to incorporate a guide for the introduction of standardized horizontally unfavourable osteotomies at the angle of the replica hemi-mandibles. The sectioning procedure will be undertaken simultaneously with the preparative procedures adopted for mini-plate localisation. The template will feature two corresponding and linearly aligned bi-cortical engaging guiding trenches, ± 5 mm in length located on the upper and lower aspects of the template allowing orientation slots to be cut into the surface of the synthetic mandibles. Standardised sectioning will be obtained by linear connection of the prepared slots after removal of the template and employing a reciprocating saw with a blade width of 0,9mm for segmentation.

6.3 MINI-PLATE FIXATION PROCEDURES

The osteomised segments will be connected (fixated) by means of the experimentally designed and prefabricated titanium six-hole curved mono-cortical fixation plates identical in profile (Stryker Leibinger, Freiburg, Germany) as illustrated in (Figs. 2 and 3).

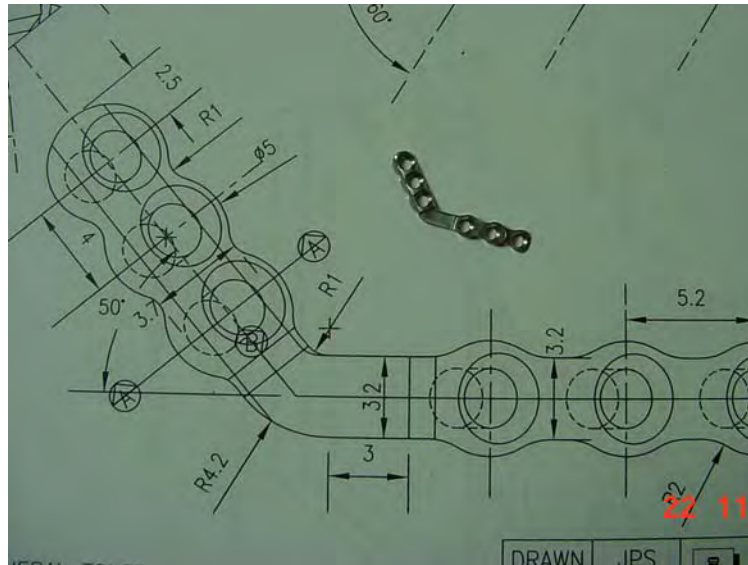

FIGURE 3. A designed curved mini-plate illustrating different screw angle placements

Identically pitched self-tapping screws, 7mm in length and 2mm in diameter, will be employed for fixation. The different mini-plates will be positioned to correspond with the previously prepared screw holes on the segments and each screw tightened to predetermined standardised interfacial pre-loads using the calibrated torque screwdriver (Fig. 4).



FIGURE 4. Calibrated torque screwdriver

The completion of preparative procedures on the hemi-mandibles necessitates accurate localisation and fixation of each individual test specimen in the testing device for 3-dimensional flexural load-displacement evaluation.

6.4 BIOMECHANICAL INVESTIGATION

The 3-dimensional stability testing device that will be used for the stability potential evaluation of the fixated test module, involves the incorporation of the test jig, as shown in Fig. 5, within the Z010 Zwick testing machine (Zwick, Ulm, Germany).

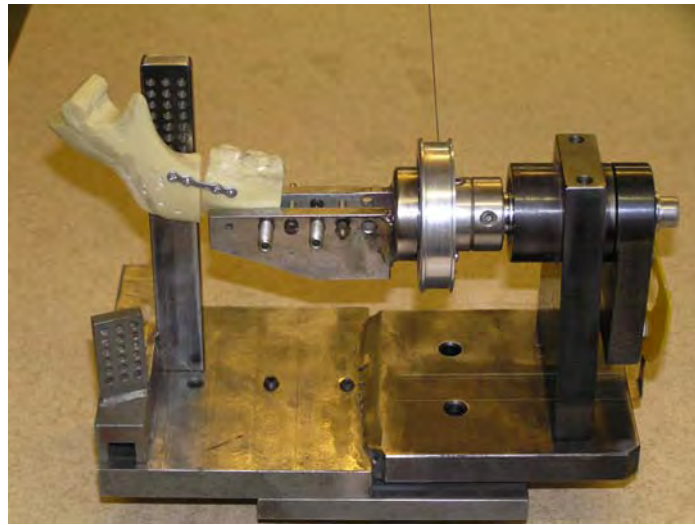

FIGURE 5. Photograph of 3-dimensional experimental jig with fixated test module

- Tension/Compression evaluation

The jig basically consists of two testing platforms. The one platform features a fixed vertical mounting plate for stabilising the experimental model in order to perform load-deflection by application of specific load at a standardised predetermined distance from the osteotomy site. The vertical load induced via the loadpin as illustrated in Fig. 6 in the Zwick machine, facilitates determination of the tensile and compressive (cantilever) displacement that occurs within the fixated test samples. All measuring will be performed by the same operator.



FIGURE 6. Photograph of loadpin in Zwick machine

Physical displacement of the segments (gapping) will be obtained from the load-displacement data. Gaps between the displaced segments will be measured using a filler taper gauge at the inferior and superior margins. Vertical displacement will be measured at the inferior boarder. The relationships between gap widths and incremental compression/tension values will be documented to produce a graphic linear regression model.

- Torque Evaluation

The second platform of the test jig consists of a rotating model holding device. This device features a round disc 4cm in diameter located on a horizontal rotational axis with a wound steel cable having a tensile breaking force of 500 Newton. One end of the cable is fixed to the disc and the other end is attachable to the loadpin of the Zwick machine. Specific load application by the Zwick machine on the wound cable, induces shear deformation on the experimental model. Torsional loads are obtained by value substitution in the following formula:¹⁵

$$D = F \times r$$

where $D = \text{Torque (Nm)}$

$F = \text{Tensile Force (N)}$

and $r = \text{radius of disc (mm)}$

The experimental validity of this formula is dependent on a constant radius. This is achieved and controlled by maintaining a constant cable to wheel angle during application and relaxing of the load.

In addition, a scale of degrees is secured to the rotating axis of the platform to record the degrees of rotation in response to tensile loading of the model as shown in Fig. 7.



FIGURE 7. Device used for measuring the degrees of rotation at specific torque applications

During loading, the physical displacement (segment gapping) in the horizontal plane, (bucco-lingual, displacement), will be linearly measured at the superior boarder, of the test module using the mentioned filler taper gauge, as illustrated in Fig. 8. The relationships between gap widths and incremental torque values will be documented and used to produce a graphic linear regression model.¹⁶

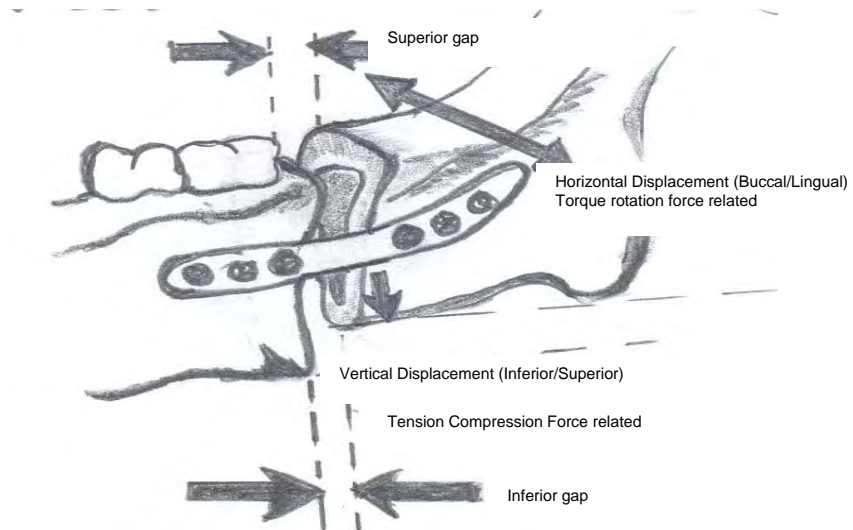

FIGURE 8. Illustration of linear displacement measurement methods utilised

- Load displacement evaluation

All the load displacement tests will be conducted in the Zwick machine. The experimental jig with the mounted test models will be incorporated within the testing machine by means of adaptor plates. The resistance to the applied tensile, compressive and shear loads will be regulated. A progressive load up to a maximum of 35 Newton will be applied to simulate clinical conditions. Loading in the system will be 10 times less than in normal human clinical conditions. This is due to discrepancies between the elastic modulus of living bone and artificial polyurethane. Therefore 1,0 Newton in the test machine is equal to 10 Newtons clinically.¹⁶ These loading parameters are based on studies of bite force in post operative patients. The assumption made is that meaningful information regarding mechanical behaviour should be obtained within the 0-100 Newton range for incisal edge loading and 0-200 Newtons range for contra lateral loading.¹⁶

The velocity of the cross-head travel of cross head travel will be regulated. Furthermore, a tension-compression load cell 50N type 8301 will be calibrated and used throughout this investigation (Fig. 4). Before each test, the experimental jig

containing the test model will be secured to the lower base of the Zwick machine and calibrated to obtain a zero deflection value on the chart recorder. The load displacement characteristics will be recorded on the computerised chart recorder. From the known deflection values on the chart recorder, it will be possible to derive the stability values of each fixation design relative to the magnitude of the applied load.

Before experimental stability determination of the prepared test models, five unprepared intact hemi-mandibles will be used as controls to define the limitations of the substrate (synthetic mandible replicas) and testing jig.

Incremental load displacement testing with zero, five, fifteen, twenty five and thirty five Newton will be conducted to determine the stability of fixated test samples for two modes of load applications, tested as tension/compression and torsion.

Furthermore, the amount of physical displacement of segments (gapping) that occurs during the two modes of loading, will be obtained.

7. RESULTS

The results obtained during the course of the investigation will follow an outline similar to that used in presenting the load displacement evaluation of the experimental procedures. A summary of computed results and the statistical analysis will be presented in tabulated and graphic format.

The tension/compression and torque load displacement results obtained from these evaluations will be separately tabulated as a load/displacement series of individual group values for each of the four different fixation categories. The average values of each categories will each be depicted individually and comparatively in graphic illustrations.

The mean and standard deviations will be derived from the abovementioned data tables and compared for statistical significance within the fixation categories using a one-way analysis of variance ($P < 0.05$) and tabulated.

7.1 TENSION/COMPRESSION DISPLACEMENT RESULTS

The physical linear superior displacement values measured in millimetres, will be derived from the load/displacement data and tabulated for each fixation category in the test series.

The mean and standard deviations will be derived from the tabulated results, compared for statistical significance within the fixation categories using one-way ANOVA ($p < 0.05$) and tabulated.

The dependence of gap width on cantilever load will be graphically demonstrated by means of a simple linear regression model for comparative evaluation of the different fixation categories.

7.2 TORSIONAL DISPLACEMENT RESULTS

Similarly, the physically linear lateral gap displacement expressed in degrees of rotation in response to the applied torsional loads, will be tabulated.

The mean and standard deviations, obtained from the tabulated results, will be compared for statistical significance within the fixation categories using one-way ANOVA ($p < 0.05$).

The relationship between gap width and torsional loading will be graphically illustrated using first-order polynomial best-fit curves for comparative evaluation of the different fixation categories.

7.3 COMPARATIVE RESULTS

The clinical relevance relating to trans-buccal screw application and its preferred more cost effective alternative, the intra-oral approach, as it applies to screw angle placement, will have been researched.

8. OUTCOMES

8.1 BACKGROUND

8.2 THE PILOT/FEASIBILITY STUDY

Mono-cortical management of mandibular fractures – A new plating system (MIMAS).¹⁷

Presentations:

Topic: Minimal – invasive – Mono-cortical – angle -system – Load sharing and load bearing forces : IADR Congress Pretoria, September 2004

- Presented:
1. Jacobs F.J., Botha S.J.¹⁷ (as abstract)
Facial Trauma Congress
University of the Witwatersrand
February 2003
 2. Jacobs F.J., Botha S.J.¹⁷ (as abstract)
16th International Conference on Oral and Maxillofacial Surgery
Athens, Greece
May, 2003¹⁷

Innovative developments

Design and manufacture of:

- Biomechanical test jig
- 60° angulated plates

8.3 ENVISAGED OUTCOMES

It is envisaged that the results of this study should lead to:

8.4 PhD THESIS

8.5 PRESENTATION

Angled intra-oral plating system (AIOPS)17th International Conference on Oral & Maxillofacial Surgery, Vienna, Austria September 2005

8.6 PUBLICATION

To be publish and in relevant Scientific Journals

9.	EXPERIMENTAL MATERIALS	ZA Rand	
	<ul style="list-style-type: none"> • Synthetic mandibles • Manufacturing of jig and templates 		15,000 5,000
9.1	EXPERIMENTAL PROCEDURES		
	<ul style="list-style-type: none"> • Human Resources Laboratory hours (120 Hrs) Instrumentation and Labour @ R100 per hour * Software programme * Printing/Duplication of test results * Statistical analysis 		12,000 500 500 1,500
9.2	PRESENTATIONS AND PUBLICATIONS		
	<ul style="list-style-type: none"> • Presentations • Publications * Thesis * Articles 		500 10,000 1,000
	Total	ZA-Rand	46,000

10. Finance. Stryker-Leibinger Research Fund
Development fund in Department of MFOSurg,
University of Pretoria

11. ETHICAL CONSIDERATION

This in vitro study is not ethical- implicated due to Stryker-Leibinger support.

12. TIME SCHEDULE

Experimental procedure and complication of results should require
approximately 16 weeks to conclude.

For preparation and finalisation of thesis, a period of ± 2 years is envisaged.

13. REFERENCES

1. Roberts, W.R. The case for mandibular plating. *Brit J Oral Surg* 1964; 1: 200-4.
2. Worthington, P., Champy M. Monocortical miniplate osteosynthesis. *Otolaryngo Clin N Am J* 1987; 20: 607-20.
3. Tillmann B., Harle F., Schleicher A. Biomechanik des Unterkiefers. *Dtsch Zahnarztl Zeitschr* 1983; 38: 285-93.
4. Uckan S., Schwimmer A., Kumner F., Greenberg A.M. Effect of angle of the screw on the stability of the mandibular sagittal split ramus osteotomy : A study in sheep mandibles. *Br J Oral Maxillo-Fac Surg* 2001; 39: 266-68.
5. Borstlap, W.A., Stoelinga, P.J.W.A., Hoppenreijts, T.J.M., Van't Hof, M.A. Orthognatic surgery stabilization of sagittal split advancement osteotomies with mini-plates : A prospective, multi-center study with two-year follow-up, Part 1. Clinical parameters. *J Oral Maxillo-Fac Surg* 2004; 62: 892-94.
6. Kroon, F.H.M., Mathison, M., Cordey, J.R., et al. The use of union-plates in mandibular fractures. An in-vitro study. *J Craniomaxillofac Surg* 1991; 19: 235-38.
7. Levy, F.E., Smith, R.W., Odland, R., Marentette, L. Mono-cortical mini- plate fixation of mandibular angle fractures. *Arch Otolaryngol Head Neck Surg* 1991; 117: 149-54.
8. Zachariades, N., Skoura, C., Mezitis, P., Marouan, S. Pseudo-aneurysm after routine trans-buccal approach for bone screw placement. *J Oral Maxillofac Surg* 2000; 58: 671-73.
9. Guimond, C., Johnson, J.V., Marhena, J. Fixation of mandibular angle fractures with a 2mm 3-dimensional curved angle strut plate. *J Oral Maxillo-Fac Surg* 2005; 63: 209-14.
10. Ellis, E., Walker, L Treatment of mandibular fractures using two non-compression mini-plates. *Oral Maxillo-Fac Surg* 1994; 52:1032-6.
11. Pruijm, G.J., de Jongh, H.J., ten Bosch, J.J. Forces acting on the mandible during bilateral static bite at different bite force levels. *J Biomech* 1980; 13: 755-60.
12. van Eijden, T.M. Three-dimensional analyses of human force magnitude and moment. *Arch Oral Biol* 1991; 36: 535-9.
13. Perren, S.M., Cordey, J., Baumgart, F., Rahn, B.A., Schatzher, J. Technical and biomechanical aspects of screws used for bone surgery. *Int J Orthop Tr* 1991; 2: 31-48.
14. Smith, B.R. The anatomy of the mandible as it relates to the medial ramus osteotomy and rigid fixation of the sagittal split osteotomy (Thesis). Houston (TX): Baylor Univ., 1988.



15. Feller, K-U., Richter, G., Schmeider, M., Eckelt, U. Combination of microplate and mini-plate for osteosynthesis of mandibular fractures: An experimental study. *Int Oral Maxillo-Fac Surg* 2002; 31: 78-83.
16. Wittenberg, D.P., Mukherjee, B.R., Smith, R., Kruse, N. Biomechanical evaluation of new fixation devices for mandibular angle fractures. *Int J Oral Maxillo-Fac Surg* 1997; 26: 78-73.
17. Jacobs, F.J., Botha, S.J. The minimal invasive mono-cortical angle system, MIMAS. *Int J Oral Maxillo-Fac Surg* 2003; 32: S1-S2.



UNIVERSITEIT VAN PRETORIA
UNIVERSITY OF PRETORIA
YUNIBESITHI YA PRETORIA

Addendum 3: Biomechanical In Vitro Test

BIOMECHANICAL NOTE (internal use only)

Primary stability of angular fracture osteosyntheses

Introduction

Based on a customer suggestion, a new product was designed for fractures of the mandible angular region. This new plate helps avoiding trans-buccal access for screw fixation when applying osteosynthesis near the linea obliqua. In order to simplify the screw handling via oral access and assure cortical screw retention, the counter sink axes are non-orthogonal but inclined to the plate main plane.

A biomechanical study was used to simulate both the adaption to indication and physiological load.

Method

For biomechanical experiments, plastic mandibles were used in order to extinguish the influence of inter-individual variations of cadaveric specimens. Standardized fractures were set by perforation. The fractures were fixed monocortically by three different implants (Fig. 1, Fig. 2, Fig. 3): **Standard Würzburg 6hole plate** (Stryker 01-08206), **Universal Fracture plate** (Stryker 55-15526), and the forthcoming **MANDIBLE ANGLED FRACTURE plate** (Stryker 55-XXXXX).



Fig. 1: Application of Standard Würzburg plate according to Campy

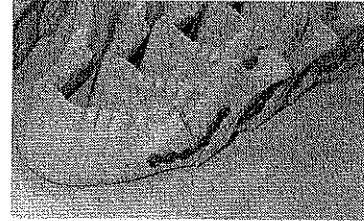

Fig. 2: Lateral application of Universal Fracture plate

K-Wires were attached in order to measure their load dependent angle changes (Fig. 3). The relative displacement of anterior and posterior fragments: **Bending [°]** (sagittal plane) and **Torsion [°]** (fracture plane).

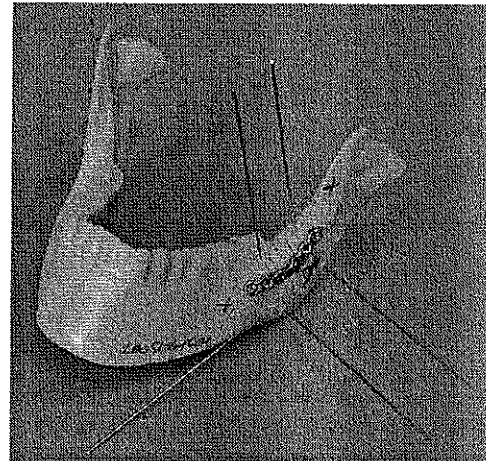

Fig. 3: Plastic mandible with forthcoming plate and K-wires

The physiological load (Fig. 4) was realized using a test rig (modified after [1]). Functional loads as dental - incisally, molar contralaterally and ipsilaterally - and muscular (M. masseter) were applied. Beginning with a preload of 20N, 5 steps of 50N (0, 50, .. 250) were examined.

BIOMECHANICAL NOTE (internal use only)

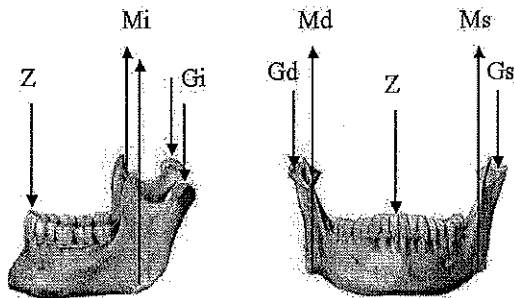

Fig. 4: Functional statical loading of the mandible: dental (Z), muscular (M) and TMJ (G)

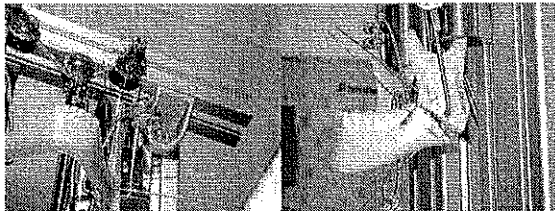

Fig. 5: Simulation of statical load situations, frontal and lateral view, 150N ipsilateral load

Results

According to Shetty et al. [2], the factor of instability was calculated: $I=(B^2+T^2)^{0.5}$ (the 3rd degree of freedom - lateral-buccal displacement - was negligible).

Depending of the location of the osteosynthesis, significant differences were observed: SW6 is attached superior to the linea obliqua and is stiffer than UF and MAF when loaded contralaterally and incisally. UF and MAF are attached laterally

References

1. Kroon, F.H.M.; Mathisson, M.; Cordey, J.R.; Rahn, B.A.: The use of miniplates in mandibular fractures. J. Cranio-Fac. Surg. 19, 199-204, 1991
2. Shetty, V.; McBrearty, D.; Fournay, M.; Caputo, A.A.: Fracture line stability as a function of the internal fixation system: an in vitro comparison using a mandibular angle fracture model. J. Oral. Maxillofac. Surg. 53, 791-801, 1995

to the mandible model and respond to all load situations, but less ipsilaterally than incisally or contralaterally.

Summing up all 3 load situations, the average factor of instability is defined by $I_g=(I_n+I_o+I_p)/3$ and its standard deviation I_x , which is considered the sensitivity balance of the 3 load situations.

Table 1: key data for 250N load

		SW6	UF	MAF
I_o	contralat. load	0.75°	4.14°	4.94°
I_n	incisally load	1.13°	3.46°	4.85°
I_p	ispilat. load	56.28°	2.27°	3.72°
I_g	average Instability	19.39° ~ 100%	3.29° ~ 17%	4.5° ~ 23%
I_x	std. dev. Instability	31.95°	0.94°	0.69°

Table 1 shows that the Standard Würzburg plate is not an option for the ipsilateral load situation. The average stability of the Universal Fracture plate is 37% higher but 13% less balanced than that of the Mandible Angled Fracture Plate.

Considering the different surgical procedure, the Mandible Angled Fracture plate has an advantage by avoiding the trans-buccal access.



UNIVERSITEIT VAN PRETORIA
UNIVERSITY OF PRETORIA
YUNIBESITHI YA PRETORIA

Addendum 4: The Mandibulator

THE MANDIBULATOR

by Heinrich Schieferstein, © 1998-2004

Introduction

The successful treatment of maxillofacial fractures requires the exact anatomical reposition of the fragments. The fixation has to stand functional loads at a minimum restraint of the function.

Currently, plates and screw of titanium are used. The history of these implants started at the end of the 19th century empirically. By now, there are two different approaches: while some surgeons propagate massive and rigid plates, other believe in the miniaturisation of plates for internal reposition.

The further development of osteosyntheses is based in simple biomechanical experiments which are geared towards clinical experiences. For the validation and optimization of the state-of-the-art concepts, more expense of theoretical and experimental investigation is required. Recent biomechanical experiments need fundamental revisions and consequent maturation.

The masticatory system carries out two main tasks: nutrition and communication. Since chewing and speaking are multi-factorial processes, their theoretical and experimental simulation require knowledge of Physiology and Biomechanics. Most of the recent models are static ones.

Total joint replacement in the lower extremity is routine for about a half century, therefore the knowledge of the in vivo loads is highly sophisticated. Test standards for fatigue and wear are given. The fields of cranio-maxillofacial surgery still miss adequate data for implant lay out and tests.

The aim of this study was the development for a tool which may be used for the experimental validation of mathematical models and the definition of characteristic load situations. Up-to-date product design is increasingly ruled by simulations. Before introducing new products to the market, their functional ability has to be proven experimentally.

Status Quo

During the last five to ten decades, many theoretical and experimental approaches have been published while the development of surgical implants is done secretly. The origin of the data used for implant layout or mathematical simulation differ considerably as far as they are published.

Experiments can be distinguished in following groups: in vivo, in vitro. While the in vivo investigations are based on animals, the in vitro experiments operate with plastic models or cadaveric materials. It suggests itself that all these attempts vary considerably. The influence of the geometry and topology of different materials used casts doubt on the comparability of resulting stress and strain which finally rule the mechanical meaning.

Mathematical models of the human masticatory system assume amount and direction of the muscular forces. Some models use measured data regarding dental forces or joint geometry. All mathematical models are based on the static equilibrium of the involved forces; the models are two or three dimensional; the function of the M. pterygoideus medialis is discussed inconsistently.

Experiments are non-dynamic and use a variety of materials: human plastic or cadaveric mandibles, porcine cadaveric mandibles, bovine ribs. The loading situation depends on the topic, whether a sagittal split, a premolar or incisal fracture. Some experiments deal with the deformation of the complete bone, usually strain gauges are applied.

A new experimental platform is required for realistic loading of mandible with or without implants. Human mandibles or plastic models have to be applied in order to reproduce the geometry and topology situation faithfully. Primary stability of the compound of bone and implant needs static experiments while fatigue tests need cyclic/dynamic performance.

Mathematical models or diagnostic data provides test parameters. Depending on the problem, physiological and pathological situations will be adjusted simplified or complex.

Mandibulator

The demands on the experimental bench in brief: versatility, reliability, robustness, easy handling and extension.

Besides static experiments for the validation of mathematical models, dynamic/cyclic operation for implants are required.

The set-up needs an adaptation to various problems regarding joint or dental loads without much expense. The measurement of mandibular deformation or fragment deviation needs

high quality level on one hand, contact free and feasible on the other hand. Handling, change and programming should be accessible for non-professional users.

Hydraulic drives were chosen for load application. The range includes 0 to 1.000 N. Eleven of the sixteen drives can be controlled in the range of 0 to 100 mm alternatively. The force diversion is realised by stretch free Nylon ropes and frictionless blocks.

As load sensors, each hydraulic cylinder has a force sensor; the artificial temporomandibular joints have three-component piezo-electric force sensor. A PC is used for both, experiment control and data acquisition. The programming is realised in LabVIEW™. The digital-analog-converter provides the analog output signal for the hydraulic control units as well as the acquisition of 42 parameters. All data is saved to disc for off-line analysis. The sampling rate 1 kHz, each force signal has a resolution of 12 bit (by 1.000 N or 100 mm). The number of cycles, optional comments is included in the log-file. The fragment shift or mandibular deformation is measured using a standard motion analysis system. Up to three cameras observe the mandible or fracture localisation. The video data is utilized by motion analysis software.



Mandibulator © 1998-2004: Heinrich Schieferstein



UNIVERSITEIT VAN PRETORIA
UNIVERSITY OF PRETORIA
YUNIBESITHI YA PRETORIA

Addendum 5: ISI – Plate: White Paper

Management of Mandible Angle Fractures -A different Angle to fixation- The Inclined Screw Insertion (ISI) Plate.

By Frederick J Jacobs, MChD, FCM (MFOS) SA, BChD (Hons).

Pretoria Academic Hospital, Assoc. Prof University Pretoria.

Fractures of the mandible angle is second most common only to parasymphseal fractures of the mandible and often present as an indirect fracture associated with a direct fracture in the corpus on the contra lateral side . Rigid internal fixation of fractures in the angle is challenging, even in the hands of experienced trauma surgeons and is associated with very high incidence of post-surgical complications. Superior border mono-cortical plating for single simple fractures, where sufficient retro-molar bone is available, is the preferred method of treatment. Inferior border gapping under compression loading and possible insufficient biomechanical stability during contra-lateral loading with torsion forces are unresolved issues. At best, even in ideal situations when applying screws in the proximal 2 or 3 plate-holes at the conventional 90 degree angle during superior border plating,

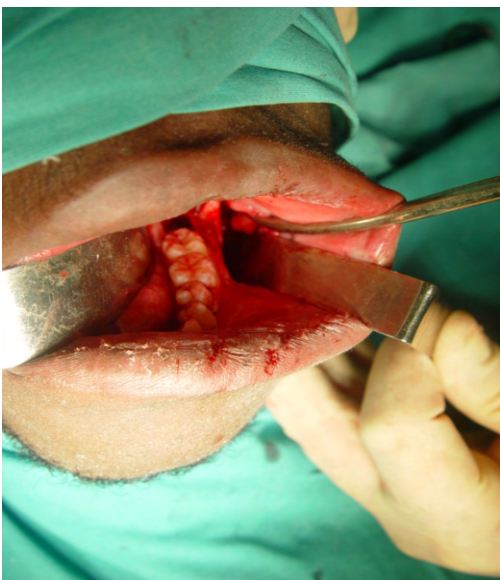

requires approach from the contra-lateral side when pilot drilling and applying screws. This in turn demands temporary removal of the inter-maxillary fixation - wiring used to establish occlusion, alignment and reduction of the fracture fragments. Tooth removal in the fracture line is required in cases with root/crown fracture or where pre-existing pathology is evident .Loss of bone contact in the retro-molar tooth-socket compromises simple superior border plating due to lack of bone buttressing of fracture segments in the superior aspect.

All rigid internal plating systems applied to the lateral aspect of the Ramus/angle according to the second Schamper ideal osteo-synthesis line (located inferior-lateral to the External Oblique ridge) demand trans-cutaneous approach in order to conventionally place screws perpendicular (90) to the plate surface. Trans-cutaneous use of an introducer can result in



complications such as haematoma, false aneurysms, nerve fall-out, skin scarring, and always results in extended operating- time .



The ISI mandible angle fracture plate is a mono-cortical 2mm. trauma plate with plate-holes angled at 60degrees for screw application from intra oral . Applied as a mono-planar , mono-plate to the caudal aspect of the External Oblique Ridge and anterior Ramus this bendable 6-hole plate specifically allows plating of the lateral aspect of the mandible via intra-oral approach saving time, is easy to

apply ,drilling at plate holes with direct vision at an angle dictated by the plate holes ensuring a stable result.

Drilling in quadrant 2 & 3 – where 2 is the angle for drilling pilot holes in the ramus section of the ISI-plate and where 3 represents the angle for drilling pilot holes in the anterior corpus section of the ISI-plate

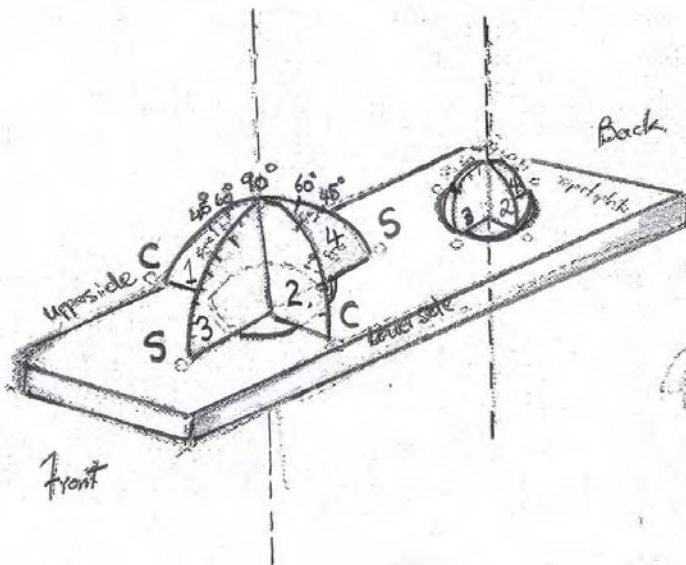

Clinical Quadrant 2

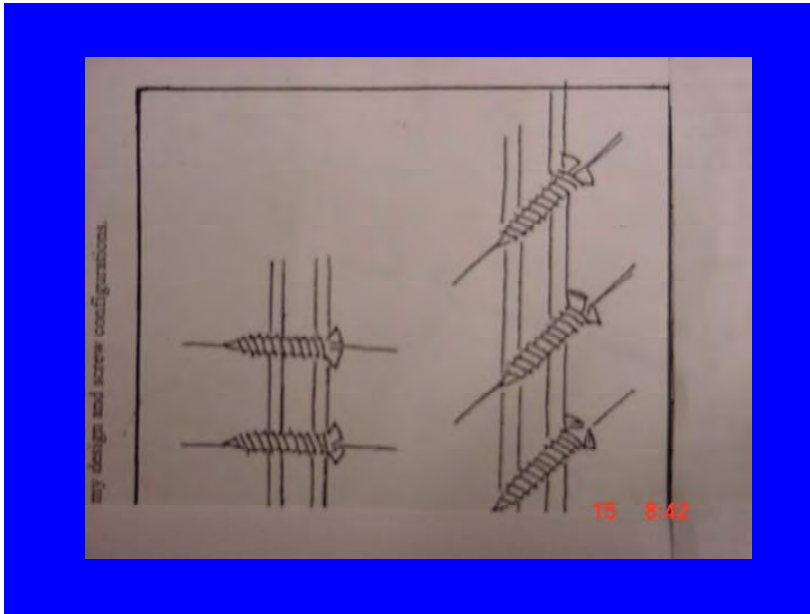

Screws inserted at 60° or 45° have a larger area of contact in the bone cortex and provide the greatest degree of resistance to movement.

A. The ISI mandible angle fracture plating system.

1. The Trauma Plate.
2. The holding/ drill-guide instrument.

1. This titanium 6-hole trauma plate -Has 60 degree slanted plate holes in an anterior to posterior direction allowing direct view into the plate-holes for pilot drilling of the bone with a 1,5mm.drill via intra-oral technique in-line of sight. The profile is 2.0mm to accommodate angled plate-holes with the ramus (cranial) 3-hole and corpus (caudal) 3-hole sections bridged by a mid section at an angle of 145 degrees,

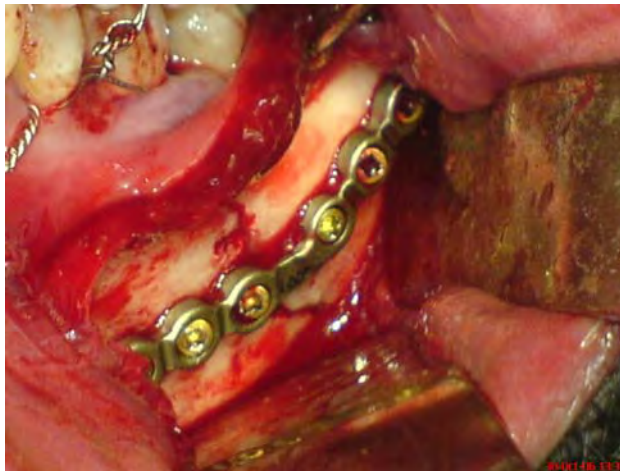

technique in-line of sight. The profile is 2.0mm to accommodate angled plate-holes with the ramus (cranial) 3-hole and corpus (caudal) 3-hole sections bridged by a mid section at an angle of 145 degrees,

An angle determined by cadaver studies of the External Oblique ridge serves as a universal angle 145 degrees, to exclude template measuring prior



to placement. This unique plate is bendable although seldom indicated and uses standard 2 mm.diameterscrews from the Stryker/Leibinger range. (fig.1.)

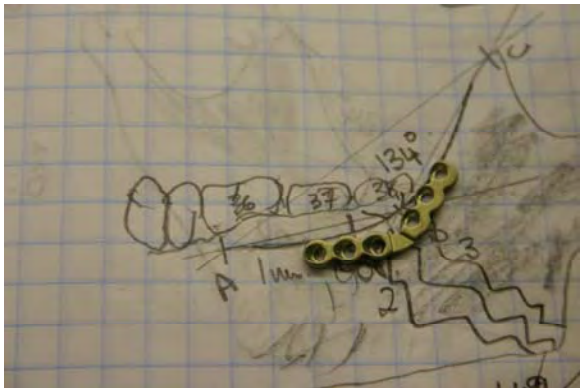

It is known from recent in vitro studies that bicortical intra oral screw placement at 60 degree angle to the saggital plane does not require extra oral trans buccal approach (S.Uckan, A. Schwimmer, F. Kummer & A. M. Greenberg, B.J. of OMF Surg. 20 March 2001).

If the same would be true for monocortical screw placement changing the screw angle design from perpendicular to 60 degrees would facilitate intra oral placement.

(A) The six-hole plate. The inclined Screw Insertion (ISI) Mandibular



angle fracture plate (MAFP)-Is a six hole trauma plate with a bridging section between the cranial 3-holes intended for application to the anterior, ramus of the mandible and the caudal 3-holes intended for application to the ventral, lateral aspect of the External Oblique ridge

(Fig.1)

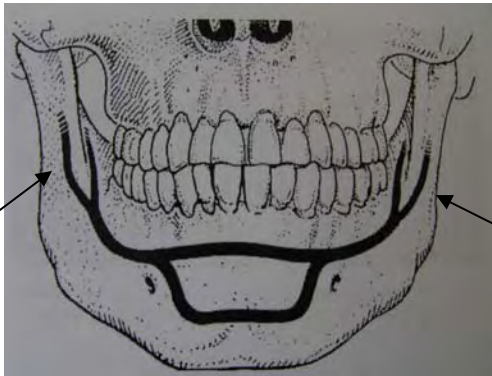
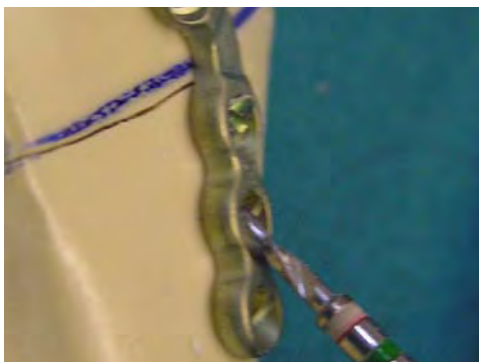

Plate fixation is performed with standard 2mm. screws according to the Schamper ideal line for osteo-synthesis in the angle of the mandible. (Fig. 2)

The trauma plates for the left and right sides are laser marked and have plate-holes at an angle of sixty degrees in the direct line of vision for pilot drilling and screw application at this angle. The plate profile is 2mm and the edge of the plate holes guide a standard pilot drill of 1,5mm diameter along the inner surface, permitting a drill at what you see, during pilot drilling and screw insertion. Pilot- drilling (Fig 3)



Why Angled screw placement and not conventional perpendicular screw fixation?

1. Superior biomechanical stability.

Greater degree of resistance to movement demonstrated in laboratory testing for both tension compression and torsion loading.



Screw application at 60 degree angle.
In vitro –poly urethane mandible-
laboratory testing.

Note the lag effect of angled screw
crossing the fracture line at 60 &45
degree insertion (arrow above).Extreme
biomechanical stability improvement
demonstrated in graph below;

Cantilever Testing – Screw angle application 45°

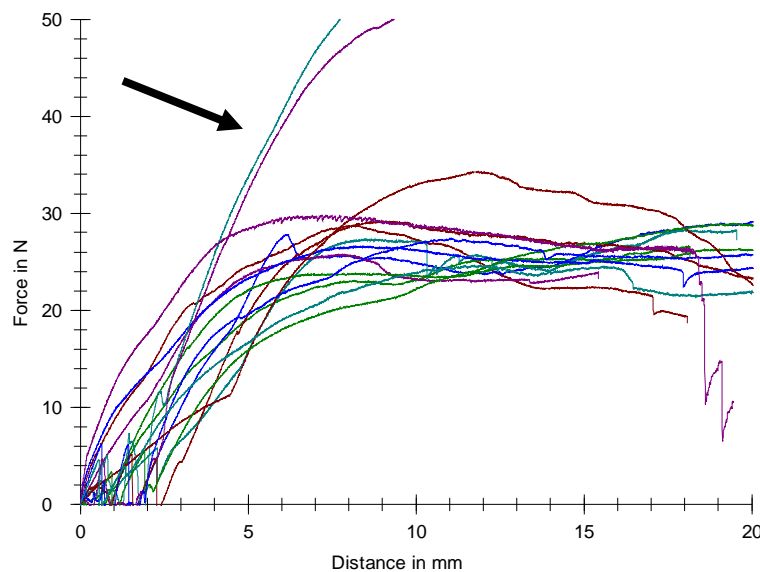

2. Intra-oral surgical technique for fixation of a trauma plate to the lateral aspect of the ramus is now possible due to angled screw- application.

All other conventional perpendicular screw placement systems used mono-planar in mono-plating of the lateral ramus, require trans-buccal instrumentation with related patient complications and longer operating time.

3. No Post-operative Inter- maxillary Fixation (IMF) required- even in partial load bearing.

4. Used in cases with additional mandible fractures to the angle presenting either as direct or indirect fractures of the symphysis and/or corpus or bilateral angle fractures.

4.1 Pre-Operative X-ray of Right Angle with left corpus fracture.



plates for left corpus.

4.2 Post operative X-Ray with ISI mandibular angle plate and two parallel

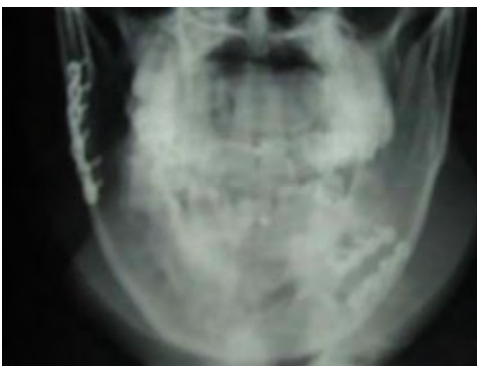

5. Indicated in cases where retro-molar region is compromised due to bone loss , infected wisdom teeth in fracture line or lack of sufficient bone surface for screw placement in the proximal fragment when placing a superior border plate.

6. Cost effective and bio-mechanically stable as a single mono-cortical trauma plate.

7. Can be used in any load sharing mandible angle fracture.

8. Simple intra-oral surgical technique –no need to temporary remove IMF in order to facilitate pilot drilling of the proximal plate holes across the occlusion from the contra lateral side.

9. Minimal plate bending required to conform to the most anterior ramus and ventral aspect of the external oblique ridge.

10. Ease of Application.

The holding device/drill guide -A instrument for gripping the plate when fitting it to the lateral aspect of the ramus prior and after bending. The holding device engages the outer profile of the first plate-hole by means of four pins –designed and positioned to enable lip clearance of the instrument when used. The holding instrument is a positioning aid to hold the plate, and may, after bending, serve as a drill-guide for drilling at 60 degrees when pilot drilling hole Nr. (2).

Surgical technique.



Using .045mm. ligature wire, eyelet wires are made, positioned according to the patients dentition and spaced to optimize the reduction stability. An incision is made intra-orally similar to the buccal soft tissue approach to the bone for a sagittal split osteotomy which includes anterior ramus stripping and limiting sub periosteal

stripping to just caudal of the external oblique ridge. A curved clamp may be applied to the anterior superior aspect of the ramus to assist in soft tissue retraction .A firm tissue retractor is used to retract the soft tissue pocket buccally- the patients head is rotated to the opposite side. After tooth removal and fracture line debridement the fracture segments are reduced and stabilized using inter maxillary fixation (IMF) and can be additionally fixated using a temporary superior border wire osteo-synthesis. The plate is bend with plate benders if required, available on the 2mm. trauma plating sets, and held by means of the special holding device clamped to the first plate-hole .The ideal plate position is the most anterior aspect of the ramus ,with the fourth plate-hole, of the cranial section of the ISI –plate just on the proximal edge of the fracture line and the anterior bar of the plate just caudally of the external Oblique ridge. The ISI mandible

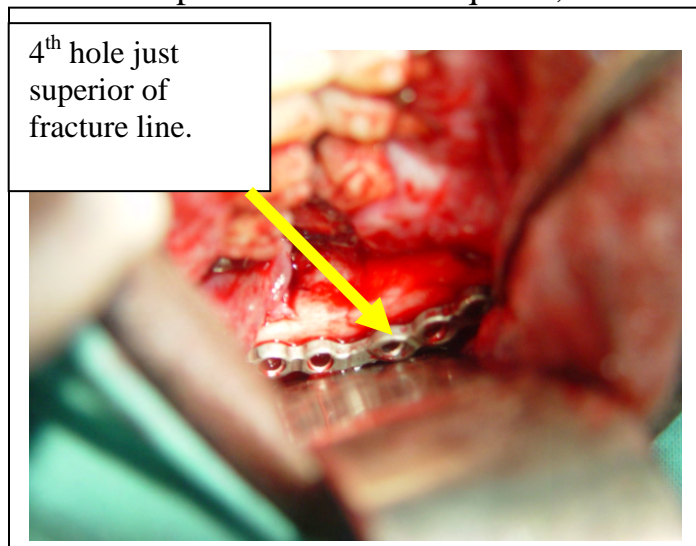

angle fracture plate is available as a universal plate and can accommodate an External Oblique angle up to 145 degrees (a template will serve as indication for larger angles to use a 160 degree plate). It is also possible to rotate the anterior bar with its three plate-holes at the connecting bar in a anticlockwise fashion for left angle plates and clockwise for right sided angle plates to fit

the distal fragment in this situation the plate would be more superiorly on the external oblique ridge.

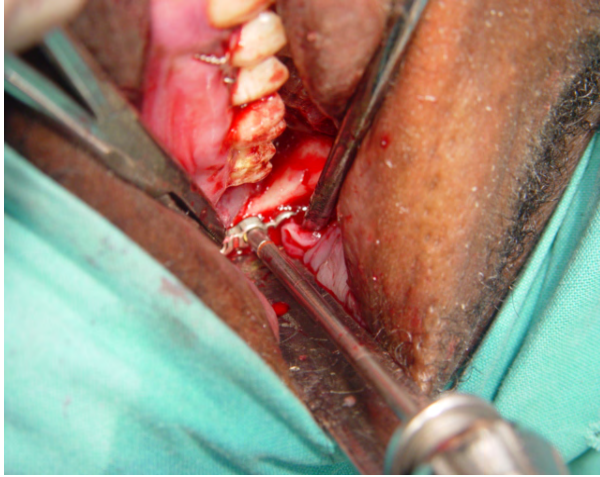

The first plate-hole to be pilot drilled is the fourth hole from the front (the first hole after the connecting bar section) drilled whilst positioning with the holding instrument gripped at the first hole –no drill guide assistance is needed when running the 1,5mm. pilot-drill along the inner surface of the plate-hole inclined at 60 degrees. A standard 2-mm. screw is inserted before holding instrument

removal , this screw is tightened after final plate rotation adjustment is done. The sequence of screw placement to follow demands that at least a screw in plate-hole position one or two is placed and tightened before placing the lag screw in plate hole Nr. 3. this is essential to stabilize the fracture segments prior to lagging screw Nr.3 –pilot drilling across the fracture line will give an impression of screw length to be placed anything from 10-15mm. length. Screw lengths of at least 7mm. are placed in other plate-holes with 7-9mm. lengths for the ramus- screws

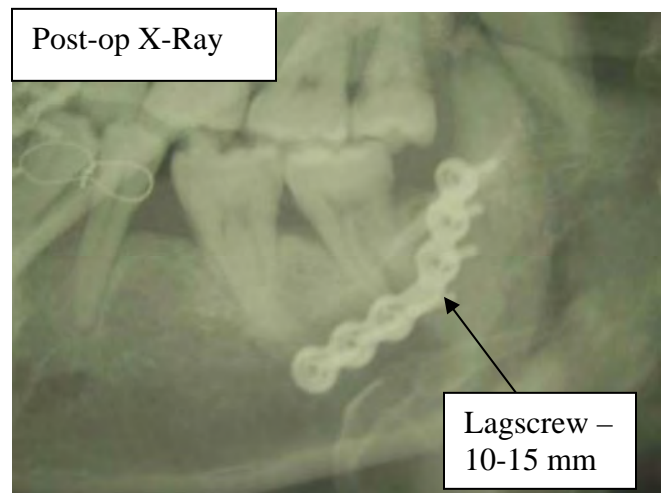
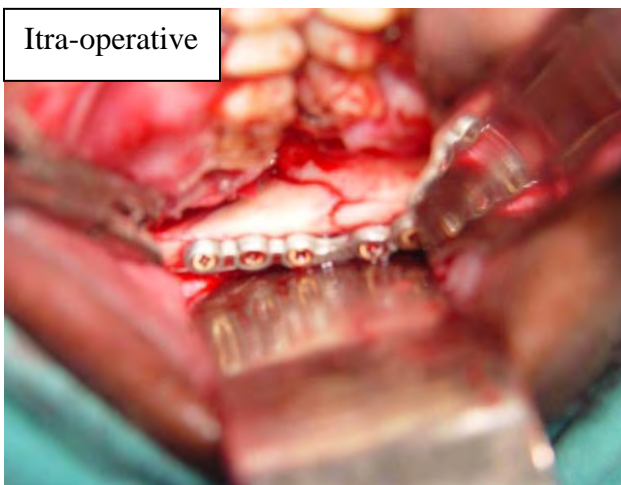



Case Reports and results:

Case 1: Bone loss – additional IMF post-op



Case 2:





Case 3:

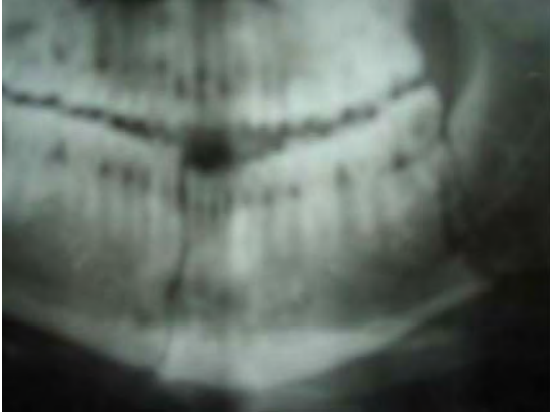

Case 4:



Biomechanical Stability Studies;

Results of a comparative study on the stability of rigid fixation, using screws of the same length and amount of torque where all variables were standardized except the angle of placement, clearly demonstrated that screw angles 60° & 45° rendered superior and significant better stability for both compression and torsion forces in a mono-cortical application.

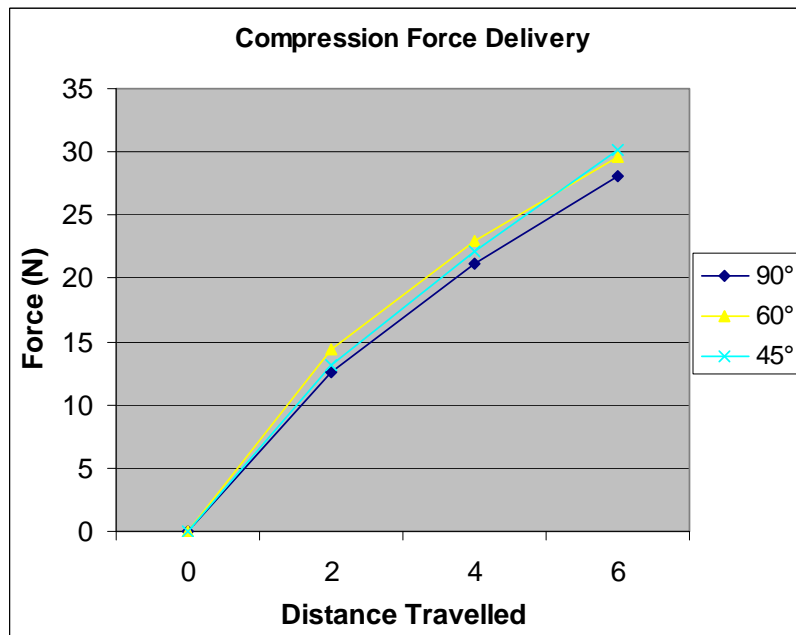
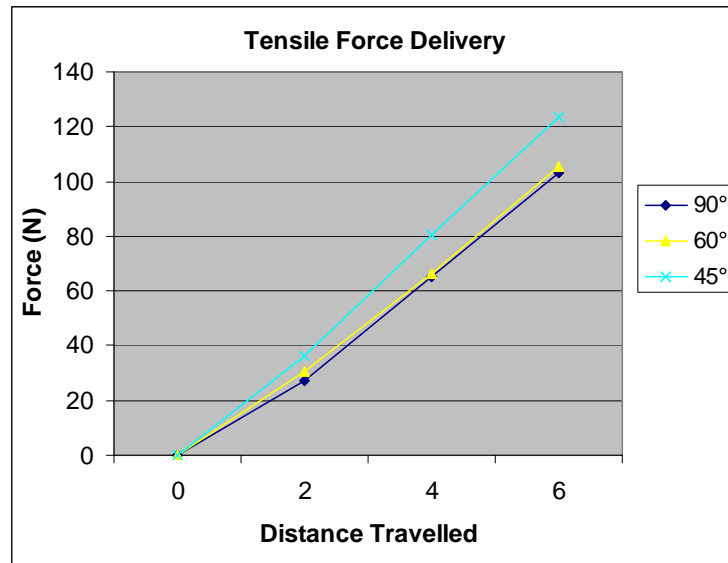



Results.

At the Pretoria Academic hospital 25 cases with mandibular angle fractures were successfully treated with the newly developed ISI mandibular angle fracture plate .Of this total , 21 were bilateral fractures and 1 a case with cortical bone loss and 3 were simple angle fractures . All cases except the bone loss case were treated without any IMF in the post operative healing period. All the fractures healed without any complications and 12 cases treated were older than 10 days post trauma when repaired.

In a retrospective analysis of 2,609 cases of mandibular fractures treated between period January 2000 and May 2004 with teeth involved by Dr. J P White , teeth were present in the fracture line in 85% of cases. Mandibular fractures occurred more in males (88%) than in females (12%).The most common sites of teeth in the fracture line were the angle fractures (64%), parasymphysis (26%),corpus (17%) and the symphysis (10%).

Conclusion.

The ISI Mandibular angle fracture plate renders a fast simple, intra oral surgical technique solution to any load sharing angle fracture of the mandibula and adds a new dimension to the Maxillofacial surgeons armamentarium for the mono-cortical management of all angle fractures, saving time and complications as no trans-cutaneous technique is employed for the lateral application of this plating system.

The angled screw application is unique and superior to conventional perpendicular screw application and results in screw lagging across the fracture line, the use of longer screw lengths with larger area of contact in dense compact bone cortex as a mono-cortical system and is a mono- plating system applied to the lateral aspect of the angle of the mandibula resulting in biomechanical stability for compression and torsion forces superior to any mono cortical system available .The surgeons scope for the effective intra-oral mono-cortical treatment of angle fractures is expanded to also include bilateral fracture situations . From patient perspective ensures no IMF in the post operative healing period , minimal post-operative complications as teeth in the fracture line can at all times be removed (even with radiographic evidence of chronic low grade infection around impacted wisdom teeth) and should the need arise for later removal of the plate the angled screws can easily be exposed and in direct line of vision, through intra-oral approach , be removed- as apposed to perpendicular screws on the lateral aspect of the ramus.



UNIVERSITEIT VAN PRETORIA
UNIVERSITY OF PRETORIA
YUNIBESITHI YA PRETORIA

Addendum 6: USA Patent Registration

By advance e-mail: fjjacobs@medic.up.ac.za

~~REGISTERED~~

Prof. Fred J. JACOBS
313 Vista Drive,
Faerie Glen,
Pretoria, 0043
SÜDAFRIKA

PATENTANWÄLTE:
AXEL VON HELLFELD, DR. DIPL-PHYS.
JOBST WIBBELMANN, DR. DIPL-CHEM.
STEFFEN J. SCHMIDT, DIPL-ING.
ANDREAS BEYER, DR-ING.
RAINER RÖTHINGER, DIPL-PHYS.
BERNHARD THUM, DIPL-ING.
AXEL KATÉRLE, DIPL-ING.
SILVIA SCHICKER, DR-ING.
ERICH FRITSCHÉ, DR. DIPL. NATW. ETH.
RAINER GUNZELMANN, DIPL-ING. (UNIV.)
RALPH-P. ANDERSEN, DR. DIPL-PHYS.

RECHTSANWÄLTE:
GERT WÜRTEBERGER, DR. JUR.
ROLAND KUNZE, LL.M., SOLICITOR (ENGL.)
TANJA WITTMANN, LL.M. (TULANE UNIV.)
BERATEND / OF COUNSEL:
RUPERT GOETZ, DIPL-ING.
DIETER BEHRENS, DR-ING.
JÜRGEN BRANDES, DR. DIPL-CHEM.
E. FRHR. VON PECHMANN, DR. DIPL-CHEM.

SCHWEIGERSTRASSE 2
81541 MÜNCHEN
TELEFON +49-89-62 18 00-0
TELEFAX +49-89-62 18 00-15
WUESTHOFF@WUESTHOFF.DE

27 May 2008
~~20 February 2008~~

National Phase in the USA 11/988,225 based on PCT/EP2006/006365

Title: Osteosynthesis plate comprising through-openings which are inclined in relation to the plane of the plate

Applicant: Stryker Leibinger GmbH & Co. KG

Our ref.: 9A-99 164

Dear Prof. Jacobs,

At the request of Stryker Leibinger we enclose formal documents which require your signature and are necessary for entering the US national phase of the above referenced international patent application. Copies of the English application text as filed and the amended claims are also enclosed.

Please be so kind and sign these formal documents where marked and return them in the original to our office as soon as possible. As this is an urgent matter, we would highly appreciate your sending these documents also by advance e-mail.

If you have any questions, please do not hesitate to ask.

Yours sincerely,

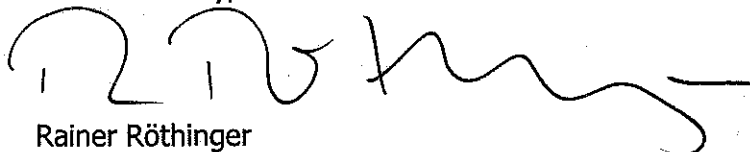

Rainer Röthinger

99

Enclosures

- Combined Declaration and Power of Attorney
- Assignment
- English application text
- Amended claims



**COMBINED DECLARATION AND POWER OF ATTORNEY
FOR UNITED STATES PATENT APPLICATION**

As a below named inventor, I hereby declare that:

My residence, post office address and citizenship are as stated near my name below.

I believe I am the original, first and joint inventors of the subject matter which is claimed and for which a patent is sought on the invention entitled:

**OSTEOSYNTHESIS PLATE COMPRISING THROUGH-OPENINGS WHICH ARE
INCLINED IN RELATION TO THE PLANE OF THE PLATE**

which is described and claimed in the specification of which:

_____ is attached hereto; attorney docket number _____.
X was filed on January 3, 2008 as United States Application Serial No. 11/988,225 which claims priority to and benefit of PCT International Application No. PCT/EP2006/006365, filed on June 30, 2006; attorney docket number 060500.00148.

I hereby state that I have reviewed and understand the contents of the above-identified specification, including the claims, as amended by any amendment specifically referred to above.

I do not know and do not believe my invention was known or used by others in the United States of America, or patented or described in a printed publication in any country before my invention thereof.

I do not know and do not believe my invention was patented or described in a printed publication in any country or in public use or on sale in the United States of America, more than one year prior to this application.

I acknowledge my duty to disclose information of which is material to patentability and to the examination of this application in accordance with Title 37, Code of Federal Regulations, Section 1.56.

I hereby claim that no application for patent or inventor's certificate on this invention has been filed in any foreign country or in the United States of America prior to this application by me or my legal representatives or assigns except as follows:



PRIORITY CLAIM

I hereby claim foreign priority benefits under Title 35, United States Code, §119(a)-(d) or (f), or § 365(b) of the foreign application(s) for patent, inventor's certificate(s), or § 365(a) of any PCT international application which designated at least one country other than the United States of America, listed below and have also identified below any foreign application(s) for patent, inventor's certificate(s), or any PCT international application having a filing date before that of the application of which priority is claimed.

 no such applications have been filed.
 X such applications have been filed as follows:

PRIOR FOREIGN APPLICATION NUMBER(S)	COUNTRY	FOREIGN FILING DATE	PRIORITY CLAIMED	CERTIFIED COPY ATTACHED
DE 10 2005 032 026.0	Germany	July 8, 2005	Yes <u> X </u> No <u> </u>	Yes <u> </u> No <u> X </u>

I hereby claim priority to and all the benefits under Title 35, United States Code, §119(e) of any United States provisional application(s).

 X no such applications have been filed.
 such applications have been filed as follows:

APPLICATION NUMBER	DATE OF FILING (month, day, year)
--------------------	-----------------------------------

I hereby claim priority to and all the benefits under Title 35, United States Code, §120 of any United States application(s) listed below. If the above identified application is a continuation-in-part application, I acknowledge the duty to disclose material information as defined in Title 37, Code of Federal Regulations, §1.56, which became available between the filing date of the prior application and the national or PCT international filing date of this continuation-in-part application.

 X no such applications have been filed.
 such applications have been filed as follows:

APPLICATION NUMBER	DATE OF FILING (month, day, year)	STATUS (patented, pending, abandoned)
--------------------	-----------------------------------	---------------------------------------



POWER OF ATTORNEY

As named inventor, I hereby appoint the attorneys and/or agent(s) associated with the below Customer Number to prosecute this application and transact all business in the Patent and Trademark Office connected therewith with full power of substitution and revocation.

CUSTOMER NUMBER: 27305

Please address all correspondence and telephone calls to:

PRESTON H. SMIRMAN, ESQ.
HOWARD & HOWARD ATTORNEYS, P.C.
The Pinehurst Office Center, Suite 101
39400 Woodward Avenue
Bloomfield Hills, Michigan 48304-5151
(248) 645-1483



DECLARATION

I hereby declare that all statements made herein of our own knowledge are true and that all statements made on information and belief are believed to be true; and further that these statements were made with the knowledge that willful false statements and the like so made are punishable by fine or imprisonment, or both, under Section 1001 of Title 18 of the United States Code and that such willful false statements may jeopardize the validity of the application or any patent issued thereon.

Dated: _____

15/07/2008

Fred J. Jacobs

Post Office and

Residence Address: 313 Vista Drive
Faerie Glen
0043 Pretoria
South Africa

Citizenship: South Africa



**ASSIGNMENT
(Patent Application - Single Inventor)**

WHEREAS I, **Fred J. Jacobs**, residing respectively 313 Vista Drive, Faerie Glen, 0043 Pretoria, South Africa, have invented certain new and useful improvements in an invention entitled

OSTEOSYNTHESIS PLATE COMPRISING THROUGH-OPENINGS WHICH ARE INCLINED IN RELATION TO THE PLANE OF THE PLATE

which is set forth in a patent application in the United States as Serial No. 11/988,225 filed on January 3, 2008, Attorney Docket No. 060500.00148; and which claims foreign priority to PCT International Application No. PCT/EP2006/006365, filed on June 30, 2006; and German Patent Application No. 10 2005 032 026.0, filed on July 8, 2005.

WHEREAS, **STRYKER LEIBINGER GMBH & CO. KG.**, a corporation having its principal place of business at Bötzingers Strasse 41, 79111, Freiburg, Germany, hereinafter referred to as **ASSIGNEE**, is desirous of acquiring said invention and said patent application and any domestic and foreign patent or patents that may be obtained therefore or thereupon;

NOW, THEREFORE, TO ALL WHOM IT MAY CONCERN, be it known that for and in consideration of the sum of One United States Dollar (\$1.00), and other good and valuable considerations, the receipt of which is hereby acknowledged, I do hereby sell, assign, transfer and set over unto said **ASSIGNEE**, its successors, assigns, or other legal representatives, the full and entire right, title and interest in and to said invention and said patent application, including the right of said **ASSIGNEE**, its successors, assigns, or other legal representatives to file any and all divisional, continuation, and continuation-in-part applications claiming priority to said patent application, or the right to seek reissues or extensions of any patent that may be issued for said invention, with the same to be held and enjoyed by said **ASSIGNEE** as fully and entirely as the same would have been held by us had this Assignment and sale not been made; and

HEREBY AGREE that I, my heirs, successors, assigns or other legal representatives will at any time upon the request and at the expense of said **ASSIGNEE**, its successors, assigns, or other legal representatives, without undue delay, execute and deliver any and all papers and do all lawful acts that may be necessary or desirable to perfect the title to said invention, said applications, and any patent or patents that may be obtained therefore; and

HEREBY FURTHER ASSIGN unto said **ASSIGNEE**, its successors, assigns, or other legal representatives, the whole right, title and interest in and to said invention throughout all countries foreign to the United States, including the right to file any foreign



patent applications claiming priority to said patent application and otherwise seek any patent in any foreign country, and including the right to file any divisional, continuation, and continuation-in-part applications claiming priority to said foreign patent application where such procedure is proper, or the right to seek reissues or extensions of any patent in any foreign country, and we do hereby ratify any acts of said ASSIGNEE in applying for a patent in said ASSIGNEE's own name in any foreign country where such procedure is proper and do hereby agree to execute said foreign patent applications in the several countries where it is necessary that the same be executed by the inventors, and to execute assignments of said foreign patent applications and any patents to be obtained therefore to said ASSIGNEE; and

HEREBY AUTHORIZE and request the Commissioner of Patents and Trademarks of the United States and any official of any country foreign to the United States whose duty it is to issue patents, to issue any patent and any reissues and extensions thereof to said ASSIGNEE in accordance with this Assignment; and

HEREBY REPRESENT and warrant that I have the full right to convey the entire interest of said invention and said applications herein assigned and have not granted any rights inconsistent with the rights granted herein.

15/07/2008
Date

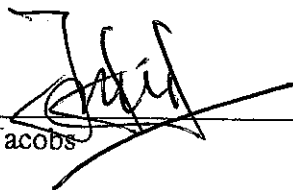
Fred J. Jacobs

Please address all correspondence and telephone calls and, upon recordation, please return this document to:

PRESTON H. SMIRMAN, ESQ.
HOWARD & HOWARD ATTORNEYS, P.C.
39400 Woodward Avenue, Suite 101
Bloomfield Hills, Michigan 48304-5151
(248) 723-1483



Osteosynthesis plate comprising through-openings which are inclined in relation to the plane of the plate

5

Field of the Invention

The present invention relates to an osteosynthesis plate with through openings inclined relative to the plane of the plate. Such osteosynthesis plates can be used to treat fractures in the region of the head and in particular to treat jaw fractures.

10

Background of the Invention

Osteosynthesis plates for the treatment of fractures have been known for more than 100 years. The most commonly used osteosynthesis plates have a linear (or elongated) shape and are provided with a plurality of through openings running perpendicular to the plane of the plate. In order to fix an osteosynthesis plate to a bone or bone fragment fastening elements (normally bone screws) are inserted through the through openings into the bone or bone fragment.

15

20

For individual cases it has proved convenient to form the through openings inclined relative to the plane of the plate. Often the provision of through openings inclined relative to the plane of the plate is connected with specific anatomical features or with special requirements, such as the generation of compression forces acting at specific angles.

25

In a linear osteosynthesis plate the alignment of through openings inclined relative to the plane of the plate can in principle be uniquely described by two angles α and β . This situation will now be described with reference to Figs. 17 and 18.

30

As illustrated in Fig. 17, a first angle α denotes the inclination of a through opening O with respect to a line S perpendicular to the plane of the plate. The plane of the plate in Fig. 10 is inclined perpendicular to the plane of the drawing. A second angle β denotes according to Fig. 18 an angular alignment of the through opening O within the plane of the plate with respect to a plate longitudinal axis L. The plane of the plate runs in Fig. 18 parallel to the plane of the drawing.

35



The angles α and β provide an unambiguous angular characterisation by restricting the first angle α to the range from 0° to 90° and having the second angle β run from 0° to 360° . In the following discussion all angles are given in the anticlockwise direction and relative to a directed reference line (for example relative to a plate longitudinal axis pointing in a specific direction).

In US 5,588,674 in Figs. 5 and 6 a linear osteosynthesis plate is illustrated, which comprises a total of four through openings inclined to the plane of the plate. Each of these four through openings intersects the plane of the plate approximately at an angle of inclination $\alpha = 45^\circ$. The inclined through opening 26b has an angular alignment $\beta = 0^\circ$ with respect to a plate longitudinal axis pointing to the free end 21 of the osteosynthesis plate 20. The remaining three inclined through openings have an opposite angular alignment $\beta = 180^\circ$.

From DE 199 62 317 A1 a linear osteosynthesis plate is known with two through openings aligned perpendicular to the plane of the plate and two through openings inclined to the plane of the plate. In this osteosynthesis plate the two through openings inclined to the plane of the plate have in each case an angle of inclination α of approximately 65° with respect to a straight line perpendicular to the plane of the plate. The angular alignment within the plane of the plate is in the case of the first inclined through opening $\beta = 0^\circ$ with respect to the plate longitudinal axis, and in the case of the second inclined through opening $\beta = 180^\circ$.

From Christian Krenkel, *Biomechanics and Osteosynthesis of Condylar Neck Fractures of the Mandible*, Quintessence Publishing Co., Inc. Carol Stream, Illinois, 1994, pp. 56 to 60, further linear osteosynthesis plates are known, which are used to treat fractures of the lower jaw. Since for aesthetic reasons (in order to avoid facial scars) fractures in the region of the lower jaw should be treated by surgical intervention from underneath the jaw, the through openings of the osteosynthesis plates are formed inclined to the plane of the plate. In the proposed osteosynthesis plates the angle of inclination α is between 30° and 90° . The angular alignment β of the through openings is either 0° , 45° , 90° or 135° .

The object of the invention is to provide an osteosynthesis plate for the treatment of fractures, in particular fractures in the region of the head such as lower jaw fractures, which can be fixed in a simple manner and with improved functionality to the bone.



Summary of the Invention

This object is achieved by an osteosynthesis plate with a plane of the plate, with a linear first section with a first longitudinal axis and extending substantially within the plane of the plate, with a linear second section with a second longitudinal axis and extending substantially within the plane of the plate inclined or staggered with respect to the first section, with at least one first through opening in the first section, which is inclined to the plane of the plate and has with respect to the first longitudinal axis a first angular alignment within the plane of the plate, and at least one second through opening in a second section, which is inclined to the plane of the plate and has with respect to the first longitudinal axis of the first section a second angular alignment within the plane of the plate, wherein the first and second angular alignments with respect to the first longitudinal axis differ from one another by less than about 60° .

Although the osteosynthesis plate at least in the basic state or as-supplied state extends substantially within a general plane of the plate, this does not prevent the plate or individual sections of the plate from being bent outwards from the plane of the plate before or during use. Thus, it may be convenient to adapt the osteosynthesis plate before its securement to a bone and/or bone fragment, by bending it to match the specific anatomical features of the fracture region. This matching is as a rule carried out by the operating surgeon. It is however also possible for the osteosynthesis plate to be bent outwards to some extent from the general plane of the plate already in the as-supplied state, so as to match anatomical features. Such osteosynthesis plates are included in the scope of protection of the invention.

The angular alignments of the first through opening and of the second through opening with respect to the first longitudinal axis serving as reference axis may be identical or different. Often angular alignments differing somewhat from one another by more than 0° or more than 10° (up to about 60° or up to about 45°) with respect to the first longitudinal axis are suitable for purposes of manipulation. It is also possible for the first angular alignment to be inclined to the first longitudinal axis and/or for the second angular alignment to be inclined to the second longitudinal axis. This means in the diagram in Fig. 18 that the angle β is chosen to be different from 0° and also different from 180° . Thus, the angle β can be chosen to be between approximately 10° and 170° , or between approximately 190° and 350° .



The angles of the first through opening and of the second through opening inclined to the plane of the plate (i.e. the angle of inclination α in the diagram of Fig. 17) can be chosen to be identical or different. The first through opening can intersect the plane of the plate at an angle of inclination of approximately 20° to 80° . Also, an angle of inclination within the range from approximately 30° to 70° is also feasible. The angle of inclination at which the second through opening intersects the plane of the plate can likewise vary in these angular ranges from approximately 20° to 80° or from approximately 30° to 70° .

According to a first variant the first angular alignment to the first longitudinal axis is between approximately $+90^\circ$ and -90° , between approximately $+60^\circ$ and -60° or between approximately $+40^\circ$ and -40° (for example with respect to a direction facing away from the second section or facing towards a free end of the first section). According to a second variant, which can be combined with the first variant, the second angular alignment with respect to the second longitudinal axis is between approximately 60° and 180° or between approximately 70° and 130° (for example with respect to a direction facing away from the first section or a direction facing towards a free end of the second section). According to a third variant, which can be combined with the first variant, the second angular alignment to the second longitudinal axis is between approximately 180° and 300° or between approximately 220° and 290° (for example with respect to a direction facing away from the first section or a direction facing towards a free end of the second section). The second variant and the third variant can be used for osteosynthesis plates for different halves of the body (right/left).

The first section and the second section can directly adjoin one another or can be connected to one another by one or more connecting sections. The connecting sections can have a linear or bent shape.

In the case of a second section inclined to the first section, the angle between the first section and the second section can be between approximately 90° to 160° and in particular between approximately 110° to 150° . The first section and the second section (or their longitudinal axes) can also run parallel and staggered with respect to one another. In this case at least one connecting section is provided between the first section and the second section. The at least one connecting section can extend inclined or perpendicular to the first and second section.



In order to enable a surgeon to carry out more easily the already mentioned matching of the osteosynthesis plate to the relevant anatomical features, the osteosynthesis plate can comprise at least one bending region of reduced plate thickness and/or reduced plate width and/or of meandering shape. According to a first variant the bending region (for example as connecting section) is formed at the transition between the first section and the second section. According to a second variant, which can be combined with this first variant, the bending region is provided between two adjacent through openings.

The osteosynthesis plate is dimensioned depending on the surgical situation in each case. In particular, in cases involving the lower jaw region the first section of the osteosynthesis plate can have a length between approximately 3 and 100 mm (for example between 5 and 60 mm and preferably between 6 and 25 mm) and the second section can have a length between approximately 3 and 100 mm (for example between 5 and 60 mm and preferably between 6 and 25 mm). The overall length of the plate can vary between 6 and 200 mm.

The osteosynthesis plate can in the region of the first section and/or in the region of the second section have a maximum plate thickness between approximately 0.5 and 3.5 mm. In one possible configuration the plate thickness is chosen so that a head of a fastening element (in any case most of it) can be sunk or embedded in the plate. In order to support the embedding of the head, the at least one first through opening and/or the at least one second through opening can include underneath a plate surface a stop means for the head of the fastening element.

In order to provide a reliable securement of the osteosynthesis plate, a plurality (for example at least 2 to approximately 5) first through openings and a plurality (for example at least 2 to approximately 5) second through openings are provided. In this connection the mutual interspacing of the first through openings can be different from the mutual interspacing of the second through openings. This arrangement is particularly convenient if the length of the first section differs from the length of the second section. The through openings can have a diameter of approximately 1.5 to 3.5 mm, preferably approximately 2 to 3 mm.

Brief Description of the Drawings

Further implementations and advantages of the invention follow from the following description of preferred embodiments and from the figures, in which:



- Figs. 1 and 2 each show a plan view of a first embodiment of an osteosynthesis plate;
- 5 Fig. 3 is a section along the line A-A in Fig. 1;
- Fig. 4 is a section along the line B-B in Fig. 2;
- Fig. 5 is a section along the line C-C in Fig. 1;
- 10 Fig. 6 is a side view of the osteosynthesis plate of the first embodiment;
- Fig. 7 is a perspective view of the osteosynthesis plate of the first embodiment;
- 15 Figs. 8A and 8B each show a perspective view of the osteosynthesis plate of the first embodiment with bone screws accommodated in through openings;
- 20 Fig. 9 is a view of a second embodiment of an osteosynthesis plate;
- Fig. 10 is a perspective view of a third embodiment of an osteosynthesis plate;
- 25 Figs. 11A and 11B each show a perspective view of a fourth embodiment of an osteosynthesis plate with bone screws accommodated in through openings;
- 30 Figs. 12A and 12B each show a perspective view of a fifth embodiment of an osteosynthesis plate with bone screws accommodated in through openings;
- 35 Figs. 13A and 13B each show a perspective view of a sixth embodiment of an osteosynthesis plate with bone screws accommodated in through openings;



Figs. 14A and 14B show two perspective views of a further osteosynthesis plate, in particular for treating jaw fractures;

5 Figs. 15A and 15B show in the linear base state and bent application state a further osteosynthesis plate, in particular for treating jaw fractures;

10 Fig. 16 shows in the linear base state a further osteosynthesis plate, in particular for treating jaw fractures;

15 Fig. 17 is a diagrammatic representation of the angle of inclination α between a through opening inclined relative to the plane of the plate, and the plane of the plate itself; and

20 Fig. 18 is a diagrammatic representation of the angular alignment β within the plane of the plate for a through opening inclined relative to the plane of the plate.

25 Description of Preferred Embodiments

30 The osteosynthesis plate according to the invention is discussed hereinafter with the aid of several embodiments. Identical and corresponding elements are identified here by the same reference numeral.

35 Figs. 1 and 2 show in each case a plan view of a first embodiment of an osteosynthesis plate 10 in different alignments. Figs. 3 to 7 and Figs. 8A and 8B show further views of this osteosynthesis plate 10.

40 The osteosynthesis plate 10 consists of titanium and is suitable in particular for treating jaw fractures (in particular fractures in the region of the mandibular angle). The osteosynthesis plate 10 illustrated in Figs. 1 to 7, 8A and 8B is a plate for the right-hand mandibular angle. The plate illustrated in Fig. 9 is intended for the left-hand mandibular angle. The left-hand osteosynthesis plate of Fig. 9 is the mirror image counterpart of the right-hand osteosynthesis plate 10. For this reason the description of the right-hand osteosynthesis plate 10 applies, apart from a few exceptions, also to the left-hand osteosynthesis plate according to Fig. 9. The exceptions will be discussed in more detail in connection with the description of Fig. 9.

The osteosynthesis plate 10 according to the first embodiment extends in the as-supplied state within a general plane of the plate, which in Figs. 1 and 2 runs parallel to the plane of the drawing. The osteosynthesis plate 10 has two adjoining linear plate sections 12, 14 with associated longitudinal axes 16, 18. The two plate sections 12, 14 run inclined to one another within the plane of the plate. As can be seen from Fig. 1, the angle of intersection between the longitudinal axes 14, 16 of the two plate sections 12, 14 is approximately 130° in the illustrated embodiment. The length of the plane section 12 (measured from the point of intersection of the two longitudinal axes 16, 18 up to the free end of the section 12) is approximately 14 mm, and the length of the plate section 14 (measured from the point of intersection of the two longitudinal axes 16, 18 up to the free end of the section 14) is approximately 10 mm.

Three identically shaped through openings 20 are formed in the plate section 12, and three likewise identically shaped through openings 22 are formed in the plate section 14. The through openings 20, 22 have a diameter of 2.4 mm in the narrowest region.

The through openings 20 in the plate section 12 intersect the plane of the plate at an angle of inclination $\alpha = 60^\circ$. This situation can be seen in Fig. 3, which shows a section along the line A-A of Fig. 1. The through openings 22 of the plate section 14 intersect the plane of the plate similarly at an angle of inclination of $\alpha = 60^\circ$. This can be seen in Fig. 4, which shows a section along the line B-B of Fig. 2. As regards the definition of the angle α , reference should be made to Fig. 17.

The through openings 20 of the plate section 12 have within the plane of the plate an angular alignment of $\beta = 0^\circ$ with respect to the longitudinal axis 16. The angular alignment with respect to the longitudinal axis 16 is determined in the direction of a free end of the plate section 12. The through openings 22 of the plate section 14 have within the plane of the plate an angular alignment of $\beta = 270^\circ$ with respect to the longitudinal axis 18 (and in the direction of the free end of the plate section 14). The through openings 22 have an angular alignment $\beta = 40^\circ$ with respect to the longitudinal axis 16 of the plate section 12 (again referred to the direction of the free end of the plate section 12). The angular alignment of $\beta = 40^\circ$ of the through openings 22 of the plate section 14 with respect to the longitudinal axis 16 of the plate section 12 is shown in Fig. 1. As regards the determination of the angle β , reference should be made to Fig. 18.



In the osteosynthesis plate 10 according to Figs. 1 to 7, 8A and 8B the through openings 20 consequently have an angular alignment in the plane of the plate of $\beta = 0^\circ$ and the through openings 22 have an angular alignment in the plane of the plate of $\beta = 40^\circ$ (in each case referred to the longitudinal axis 16 of the plate section 12).

5 The difference in the angular alignments of the through openings 20 and of the through openings 22 within the plane of the plate is therefore approximately 40° .

10 As can readily be recognised especially in Figs. 3 and 4, the through openings 20 in the plate section 12 (just as the through openings 22 in the plate section 14) have an internal diameter that reduces in a step-wise manner in the direction of the lower side of the plate 24. In this way a bearing surface 26 acting as a stop means for the head of a securement element is formed in each case within the through openings 20, 22. The bearing surface 26 is formed underneath the plate surface 28 and above the lower side of the plate 24. Since in any case the lowest region of the bearing surface 26 (cf. Fig. 5) lies underneath the plate surface 28, the head of a securement element inserted into the through openings 20, 22 can be sunk at least partly in the osteosynthesis plate 10.

20 In Fig. 8A it can clearly be seen that the shanks 50 of bone screws 48 in the plate section 12 run up to the different angular alignment ($\Delta\beta = 40^\circ$) substantially parallel to the shanks 50 of bone screws 48 in the plate section 14. Furthermore, it can readily be seen in the illustration according to Fig. 8A that the heads 52 of the bone screws 48 are accommodated sunk relative to the upper side of the plate.

25 With respect to Fig. 8B it should also be mentioned that the auxiliary lines 16', 18' shown there and running perpendicular to the longitudinal axes 14, 16 serve to illustrate the angular alignment region β . As shown in Fig. 8B, the angular alignment β with respect to the auxiliary lines 16', 18' can vary by $\pm 90^\circ$, preferably by approximately 60° .

30 The planar osteosynthesis plate 10 in the as-supplied state has a plurality of bending regions of reduced plate thickness or reduced plate width. These bending regions enable the surgeon to adapt and match the osteosynthesis plate 10 to the anatomical features in the fracture region. In this connection the osteosynthesis plate 10 can by means of suitable tools such as bending forceps be bent within the plane of the plate as well as outwardly from the plane of the plate.

5 A first bending region 30 of the osteosynthesis plate 10 is according to Fig. 1 arranged at the transition between the plate section 12 and the plate section 14. As can be seen from the side view according to Fig. 6, the osteosynthesis plate 10 has in the bending region 30 a minimal width and a lower height than in regions outside the bending region 30. This step-wise reduction of the plate thickness (from a maximum ca. 2 mm outside the bending region 30 to ca. 1.5 mm in the bending region 30) and of the plate width facilitates the bending of the osteosynthesis plate 10 by the surgeon.

10 A plurality of second bending regions 32 are according to Fig. 1 formed in each case between two adjacent through openings 20 of the plate section 12 and also between two adjacent through openings 22 of the plate section 14. These further bending regions 32 are formed by regions of reduced plate width.

15 Fig. 9 shows the left-hand osteosynthesis plate 10 of a plate system, which also includes the right-hand osteosynthesis plate described above with reference to Figs. 1 to 7, 8A and 8B. As already mentioned, the left-hand osteosynthesis plate 10 is the mirror symmetrical counterpart to the right-hand osteosynthesis plate. Accordingly the basic difference compared to the right-hand osteosynthesis plate is that the
20 through openings 22 of the plate section 14 have a different angular alignment within the plane of the plate. Whereas in the right-hand plate the corresponding angular alignment $\beta = 270^\circ$, the through openings 22 of the left-hand osteosynthesis plate 10 have with respect to the longitudinal axis 18 and in the direction of the free end of the plate section 14, a mirror image-forming angular alignment $\beta = 90^\circ$. The
25 difference in the angular alignments of the through openings 22 of the plate section 14 and of the through openings 20 of the plate section 12 (in each case referred to the longitudinal axis 16) is a constant 40° .

30 Fig. 10 shows a further embodiment of an osteosynthesis plate 10 for treating fractures in the jaw region. The osteosynthesis plate 10 has two plate sections 12, 14, which are arranged parallel and staggered with respect to one another. Between the two plate sections 12, 14 is provided a connecting section 40, running inclined to each of these sections 12, 14. The connecting section 40 intersects the two plate sections 12, 14 at an angle of in each case approximately 140° .

35 Three identical through openings 20, 22 are formed in each case in each of the two plate sections 12, 14. The through openings 20, 22 intersect the plane of the plate at an angle of inclination $\alpha = 45^\circ$. With respect to the longitudinal axis 16 of the

plate section 12 and in the direction of the free end of the plate section 12 the angular alignment β of the through openings 20 within the plane of the plate is $\beta = 135^\circ$. The angular alignment β of the through openings 22 with respect to the longitudinal axis 18 of the plate section 14 and in the direction of the free end of the plate section 14 is $\beta = 45^\circ$. Referred to the longitudinal axis 16 of the plate section 12 and the free end of the plate section 12, the angular alignment β of the through openings 22 of the plate section 14 is $\beta = 135^\circ$. The angular alignments of the through openings 20 and of the through openings 22 therefore coincide with respect to the longitudinal axis 16 of the plate section 12.

A further embodiment of an osteosynthesis plate 10 for treating fractures of the mandibular angle is illustrated in Figs. 11A and 11B. The illustrated osteosynthesis plate 10 is substantially identical to the osteosynthesis plate 10 discussed with reference to Figs. 1 to 7, 8A and 8B, except as regards the angular alignments of the through openings. For this reason only the differences will be discussed hereinafter.

A further embodiment of an osteosynthesis plate 10 is illustrated in Figs. 11A and 11B. In this embodiment the two plate sections 12, 14 again enclose an angle of 130° . The through openings 20, 22 have in each case an angle of inclination $\alpha = 60^\circ$ with respect to the plane of the plate. The angular alignment of the through openings 20 of the plate section 12 within the plane of the plate (and referred to the free end of the plate section 12) is in this embodiment 90° . As in the first embodiment, the through openings 22 of the plate section 14 within the plane of the plate have with respect to the longitudinal axis 18 (and in the direction of the free end of the plate section 14) an angular alignment of $\beta = 270^\circ$. The difference of the angular alignments of the through openings 20 and of the through openings 22 within the plane of the plate is approximately 50° . The angular alignments of the through openings 20 and 22 can vary from the specified angular alignments by $\pm 90^\circ$, preferably by approximately $\pm 60^\circ$.

A further embodiment of an osteosynthesis plate 10 is illustrated in Figs. 12A and 12B, with a total of three plate sections 12, 14, 14' and a total length of approximately 40 mm. The osteosynthesis plate 10 has a substantially fork-shaped configuration. The two plate sections 14, 14' run parallel and staggered with respect to the longitudinal axis 16 of the section 12. The plate section 12 is connected to the plate sections 14, 14' by a connecting section 40, 40' bent in each case in the shape of a quarter circle.



The fork-shaped configuration of the osteosynthesis plate 10 is determined by the fact that the two plate sections 14, 14' accommodate a nerve between them (for example in the region of the lower jaw). In this way damage to the nerve due to the bone screw 48 can be avoided.

5

The through openings 20 of the plate section 12 of the osteosynthesis plate 10 and also the through openings 20, 20' of the plate sections 14, 14' intersect the plane of the plate in each case at an angle of inclination $\alpha = 60^\circ$. The through openings 20 of the plate section 12 have within the plane of the plate an angular alignment $\beta = 0^\circ$ with respect to the longitudinal axis 16 and in the direction of a free end of the plate section 12. The through openings 22, 22' of the plate sections 14, 14' have within the plane of the plate an angular alignment $\beta = 180^\circ$ relative to the respective longitudinal axis 18, 18' (and in the direction of the respective free end of the plate section 14, 14'). The through openings 22, 22' have an angular alignment $\beta = 0^\circ$ with respect to the longitudinal axis 16 of the plate section 12 (again referred to the direction of the free end of the plate section 12). The difference in the angular alignments of the through openings 20 and of the through openings 22, 22' within the plane of the plate is therefore 0° .

10

15

20

A further embodiment of an osteosynthesis plate 10 is illustrated in Figs. 13A and 13B. The osteosynthesis plate 10 illustrated there has a substantially grid-shaped configuration with two plate sections 12, 14 running parallel and staggered with respect to one another. The plate sections 12, 14 are joined to one another in the region of oppositely located through openings 20, 22 by in each case a connecting section 40. In the example illustrated in Figs. 13A and 13B, with two times three through openings 20, 22 (i.e. three per plate section 12, 14), three connecting sections 40 are therefore provided. The connecting sections 40 run parallel to one another and in this example intersect the plate section 12, 14 at a right angle. A modification of the osteosynthesis plate 10 illustrated in Figs. 13A and 13B could have, instead of two times three through openings, two times four or three times four through openings.

25

30

35

The through openings 20, 22 of the osteosynthesis plate 10 of Figs. 13A and 13B intersect the plane of the plate in each case at an angle of inclination $\alpha = 60^\circ$. The through openings 20 of the plate section 12 have within the plane of the plate an angular alignment $\beta = 90^\circ/270^\circ$ with respect to a longitudinal axis of the plate section 12 (in the example of Figs. 13A and 13B there is no preferred direction). The through openings 22 of the plate section 14 have the same angle of alignment

$\beta = 90^\circ/270^\circ$ with respect to a longitudinal axis of the plate section 14. Accordingly the difference in the angular alignments of the through openings 20 and of the through openings 22 within the plane of the plate is 0° .

5 A further osteosynthesis plate 10 with two plate sections 12, 14 is illustrated in Figs. 14A and 14B. The two plate sections 12, 14 have a common longitudinal axis 16 and are connected to one another via a meandering (U-shaped) bent connecting section 40. The osteosynthesis plate 10 can in the application state be positioned in such a way that the U-shaped bent connecting section 40 extends around a nerve. In a
10 modification of the osteosynthesis plate 10 according to Figs. 14A and 14B, at least one bone screw through opening is provided in the region of the connecting section 40.

15 The through openings 20, 22 intersect the plane of the plate in each case at an angle of inclination $\alpha = 60^\circ$. The through openings 20 of the plate section 12 have within the plane of the plate an angular alignment $\beta = 90^\circ$ with respect to the common longitudinal axis 16 (and in the direction of the free end of the plate section 12). The through openings 22 of the plate section 14 have an angular alignment $\beta = 270^\circ$
20 with respect to the common longitudinal axis 16 and with respect to the free end of the plate section 14. The difference in the angular alignments of the through openings 20 and of the through openings 22 within the plane of the plate is consequently 0° .

25 Figs. 14A and 14B show the osteosynthesis plate 10 in the base state. According to a further embodiment of the invention the osteosynthesis plate 10 can in the region of the connecting section 40 (which then acts as bending region) be deformed in such a way that the plate section 12 is inclined relative to the plate section 14.

30 A further osteosynthesis plate 10 is illustrated in Figs. 15A and 15B. The osteosynthesis plate 10 has in the base state illustrated in Fig. 15A a linear configuration with a total of eight through openings 20. The through openings 20 intersect the plane of the plate at an angle $\alpha = 60^\circ$ and have within the plane of the plate an angular alignment $\beta = 90^\circ/270^\circ$ (there is no preferred direction). The angular alignment β can vary by $\pm 90^\circ$, preferably by approximately $\pm 60^\circ$, with respect to the auxiliary
35 line 16' shown in Fig. 15B.

Fig. 15B shows the osteosynthesis plate 10 in the bent application state. The osteosynthesis plate 10 is in this example secured in the region of the front side of the



lower jawbone (therefore in the chin region) and its bent shape matches the contour of this bone. Since the through openings 20, 22 point inclined upwards, the screws 48 can be inserted intraorally (and in particular inclined from above).

5 The osteosynthesis plate according to Figs. 15A, 15B can according to a further embodiment of the invention be deformed within the plane of the plate similarly as shown in Fig. 10, in such a way that two linear plate sections running parallel and staggered with respect to one another are formed.

10 A further osteosynthesis plate 10 is illustrated in Fig. 16. The osteosynthesis plate 10 has a linear configuration and comprises two plate sections 12, 14 connected to one another via a connecting section shaped as a bending region 30. The through openings 20, 22 of the plate sections 12, 14 have an angle of inclination $\alpha = 60^\circ$ with respect to the plane of the plate. The angular alignments of the through openings 20, 22 are in each case $\beta = 180^\circ$ with respect to the free ends of the respective
15 plate section 12, 14. The difference in the angular alignments of the through openings 20 and of the through openings 22 is accordingly 180° .

20 According to an embodiment of the invention the osteosynthesis plate 10 illustrated in Fig. 16 is bent at the site of the bending region 30 in such a way that the two plate sections 12, 14 are inclined to one another in a substantially V-shaped manner.

25 The osteosynthesis plates discussed with reference to Figs. 1 to 11B are suitable for the intraoral treatment of fractures of the mandibular angle. The osteosynthesis plates described with reference to Figs. 12A to 16 are suitable for the intraoral treatment of jaw fractures in jaw regions spaced from the mandibular angle, for example in the region of the chin or condylus.

30 The existence of two or more plate sections that are aligned non-linearly with respect to one another enables even complicated jaw fractures to be treated by means of a single osteosynthesis plate. The alignment of the individual through openings in the plane of the plate and perpendicular thereto is chosen in the embodiments in such a way that the osteosynthesis plates can be fastened *in situ* by an intraoral surgical intervention, i.e. through the mouth. No transbuccal access (i.e. through the cheek)
35 is therefore necessary in order to place in position the osteosynthesis plates of the embodiments and secure them by means of suitable securement elements such as monocortical bone screws.



5 On account of the special alignment of the through openings the surgeon is able to place in position an osteosynthesis plate intraorally, carry out if necessary preliminary drillings, and then secure the osteosynthesis plate by means of several bone screws, all without the need for a transbuccal access. Conventional (longitudinally extended) straight instruments such as blades and drills are sufficient for carrying out these steps. The use of curved instruments can be dispensed with. A further advantage of the alignment of the through openings specified in the embodiments is the fact that the surgeon, despite the intraoral access, has a good field of view and can thus see exactly where he is drilling and where the bone screws are placed.

10 Although the invention has been described with the aid of several embodiments of osteosynthesis plates for treating jaw fractures, the osteosynthesis plates according to the invention are also suitable for minimal invasive treatment of other fractures in the head region (for example the face).

15 On the basis of the above description and discussion the person skilled in the art will be able to employ numerous changes, additions and modifications that are still covered by the invention. The scope of protection of the invention is limited solely by the accompanying patent claims.



Patent Claims

1. Osteosynthesis plate (10), in particular for treating jaw fractures, with
 - a plane of the plate;
 - 5 - a linear first section (12) with a first longitudinal axis (16) and extending substantially within the plane of the plate;
 - a linear second section (14) with a second longitudinal axis (18) and extending substantially within the plane of the plate and inclined or staggered with respect to the first section (12);
 - 10 - at least one first through opening (20) in the first section (12), which is inclined to the plane of the plate and has, with respect to the first longitudinal axis (16), a first angular alignment within the plane of the plate; and
 - at least one second through opening (22) in the second section (14),
15 which is inclined to the plane of the plate and has with respect to the first longitudinal axis (16) of the first section (12) a second angular alignment within the plane of the plate, wherein the first and second angular alignments differ with respect to the first longitudinal axis (16) from one another by less than about 60°.
 - 20
2. Osteosynthesis plate according to claim 1, characterised in that the first and the second angular alignments differ with respect to the first longitudinal axis (16) from one another by less than about 45°.
- 25 3. Osteosynthesis plate according to claim 1 or 2, characterised in that the first angular alignment is inclined to the first longitudinal axis (16) and/or the second angular alignment is inclined to the second longitudinal axis (18).
4. Osteosynthesis plate according to one of claims 1 to 3, characterised in that
30 the at least one first through opening (20) intersects the plane of the plate at an angle of approximately 20° to 80°.
5. Osteosynthesis plate according to one of claims 1 to 4, characterised in that
35 the at least one second through opening (22) intersects the plane of the plate at an angle of approximately 20° to 80°.



6. Osteosynthesis plate according to one of claims 1 to 5, characterised in that the first angular alignment with respect to the first longitudinal axis (16) is between approximately $+90^\circ$ and -90° .

5 7. Osteosynthesis plate according to one of claims 1 to 6, characterised in that the second angular alignment with respect to the second longitudinal axis (18) is between approximately 60° and 180° .

10 8. Osteosynthesis plate according to one of claims 1 to 7, characterised in that the second angular alignment with respect to the second longitudinal axis (18) is between approximately 180° and 300° .

15 9. Osteosynthesis plate according to one of claims 1 to 8, characterised in that the first section (12) and the second section (14) directly adjoin one another.

10. Osteosynthesis plate according to one of claims 1 to 9, characterised in that the first section (12) has an angle of approximately 90° to 160° with respect to the second section (14).

20 11. Osteosynthesis plate according to one of claims 1 to 10, characterised in that the first longitudinal axis (16) and the second longitudinal axis (18) run parallel to one another and at least one connecting section (40) is provided between the first section (12) and the second section (14).

25 12. Osteosynthesis plate according to one of claims 1 to 11, characterised in that the osteosynthesis plate (10) comprises at least one bending region (30, 32, 40) of reduced plate thickness and/or of reduced plate width and/or of meandering shape.

30 13. Osteosynthesis plate according to one of claims 1 to 12, characterised in that the first section (12) has a length between approximately 5 and 70 mm and/or the second section (14) has a length between approximately 5 and 70 mm.

35 14. Osteosynthesis plate according to one of claims 1 to 13, characterised in that the osteosynthesis plate (10) in the region of the first section (12) and/or in the region of the second section (14) has a maximum plate thickness between approximately 0.5 and 3.5 mm.



15. Osteosynthesis plate according to one of claims 1 to 14, characterised in that the at least one first through opening (20) and/or the at least one second through opening (22) has underneath a plate surface (28) a stop means (26) for a head of a fastening element.

5

16. Osteosynthesis plate according to one of claims 1 to 15, characterised in that a plurality of first through openings (20) and/or a plurality of second through openings (22) are provided.

10



Abstract

Osteosynthesis plate with through openings inclined to the plane of the plate

5 An osteosynthesis plate is described, which is suitable for treating jaw fractures. The
osteosynthesis plate has a plane of the plate as well as two plate sections 12, 14 with
associated longitudinal axes 16, 18 extending substantially within the plane of the
plate and inclined or staggered with respect to one another. Through openings 20,
22 inclined to the plane of the plate are formed in each of the two plate sections 12,
10 14. The angular alignments of the through openings 20, 22 within the plane of the
plate differ with respect to a longitudinal axis 16 serving as reference line from one
another by less than approximately 60° . In applications in the jaw region this slight
deviation of the angular alignments permits an intraoral securement of the osteosyn-
thesis plate. A transbuccal access through the cheek can thus be dispensed with.

15

(Fig. 9)

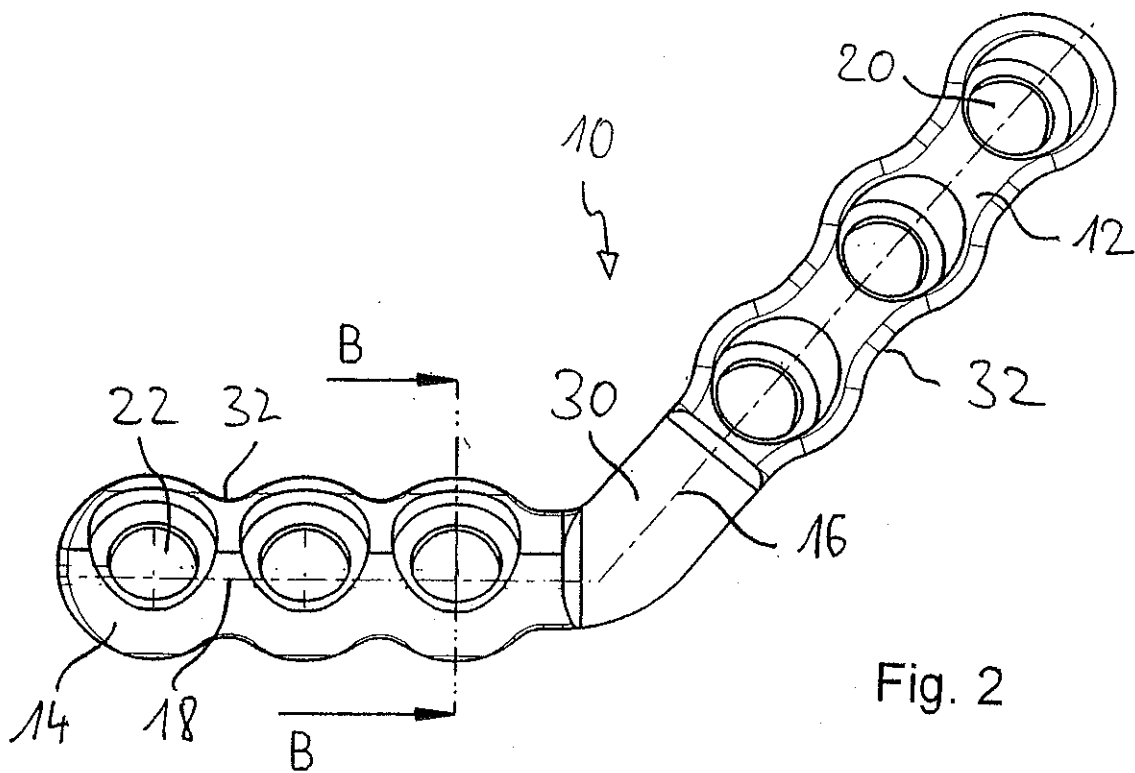
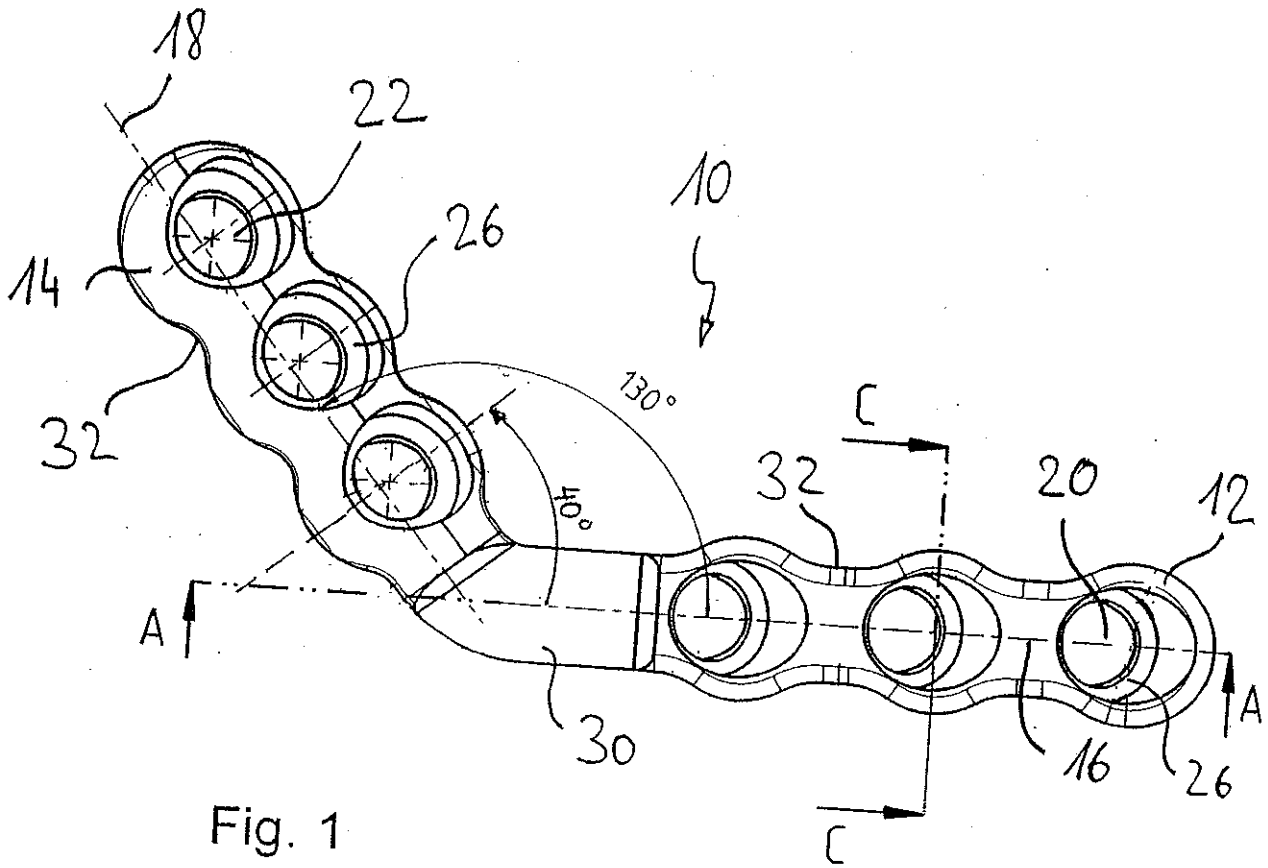

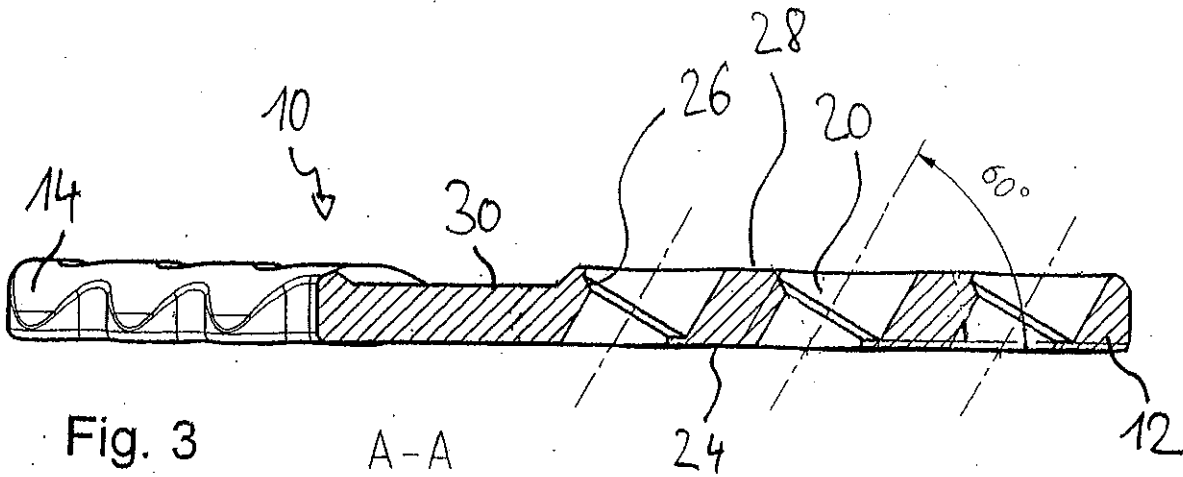

Fig. 3

A-A

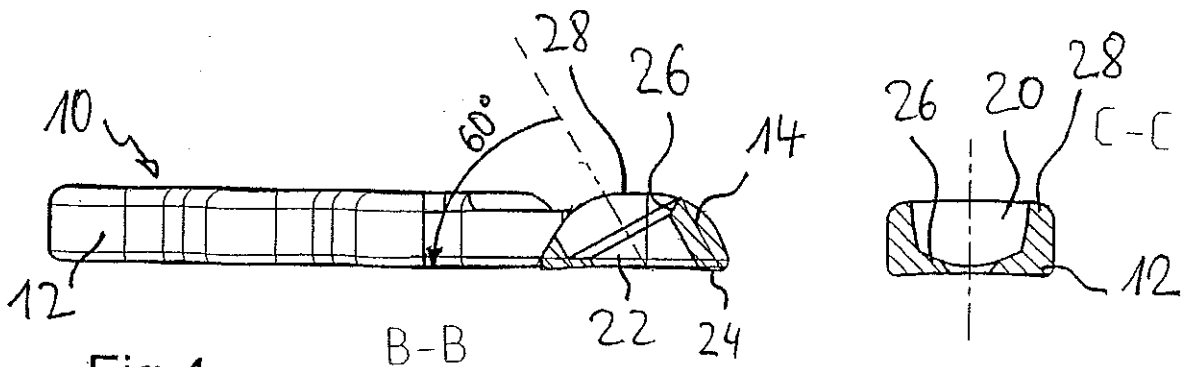

Fig. 4

B-B

Fig. 5

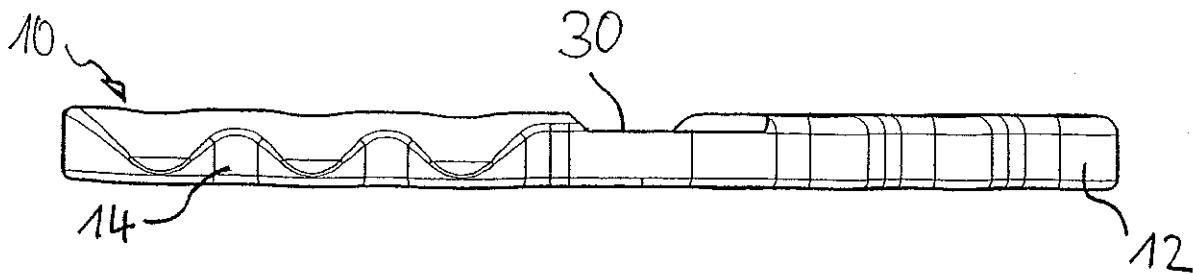

Fig. 6

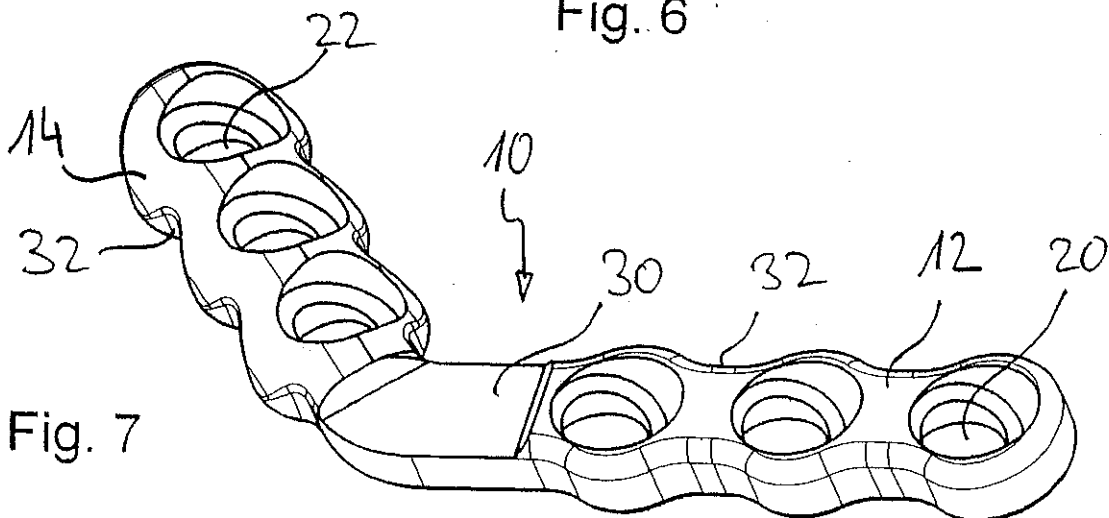

Fig. 7

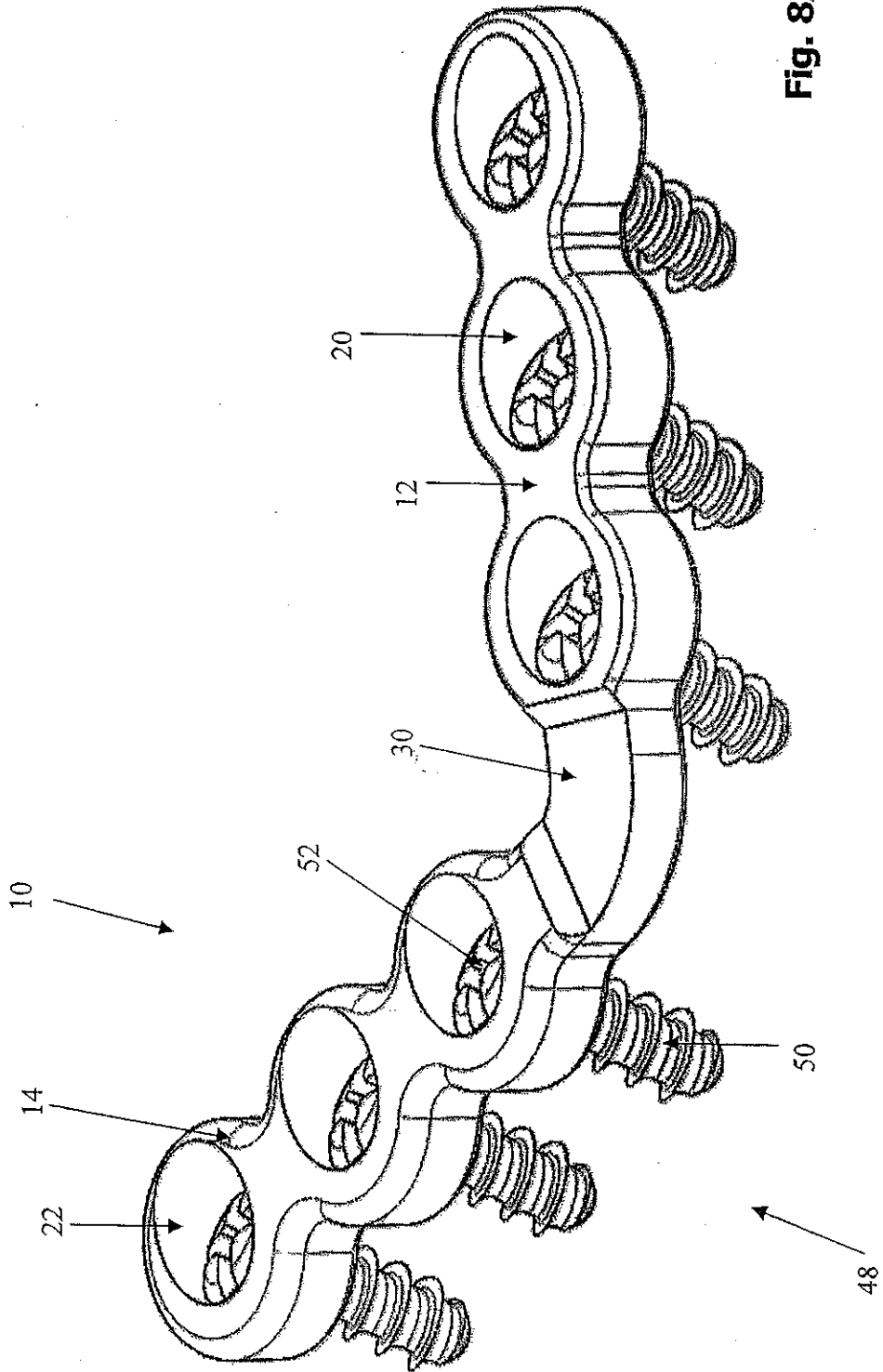

Fig. 8A

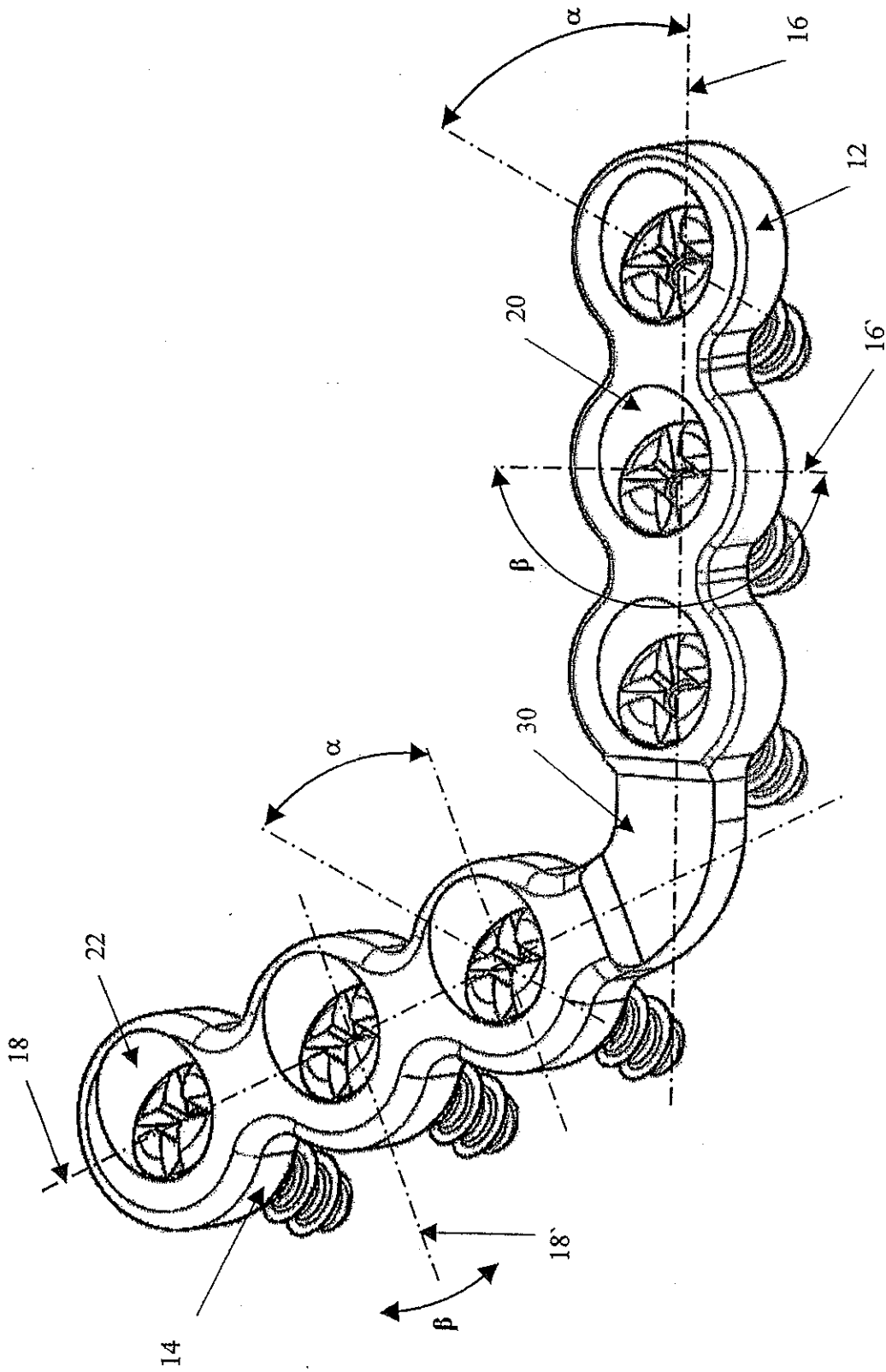
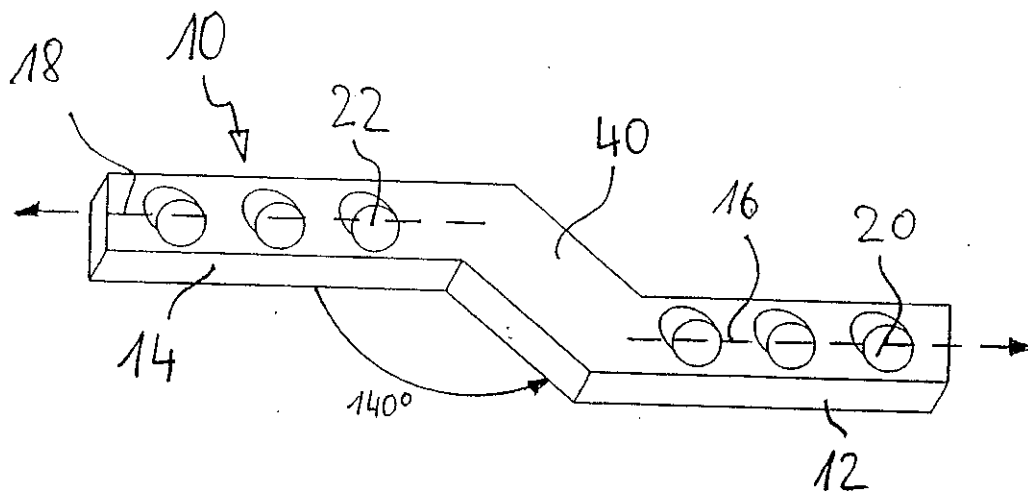
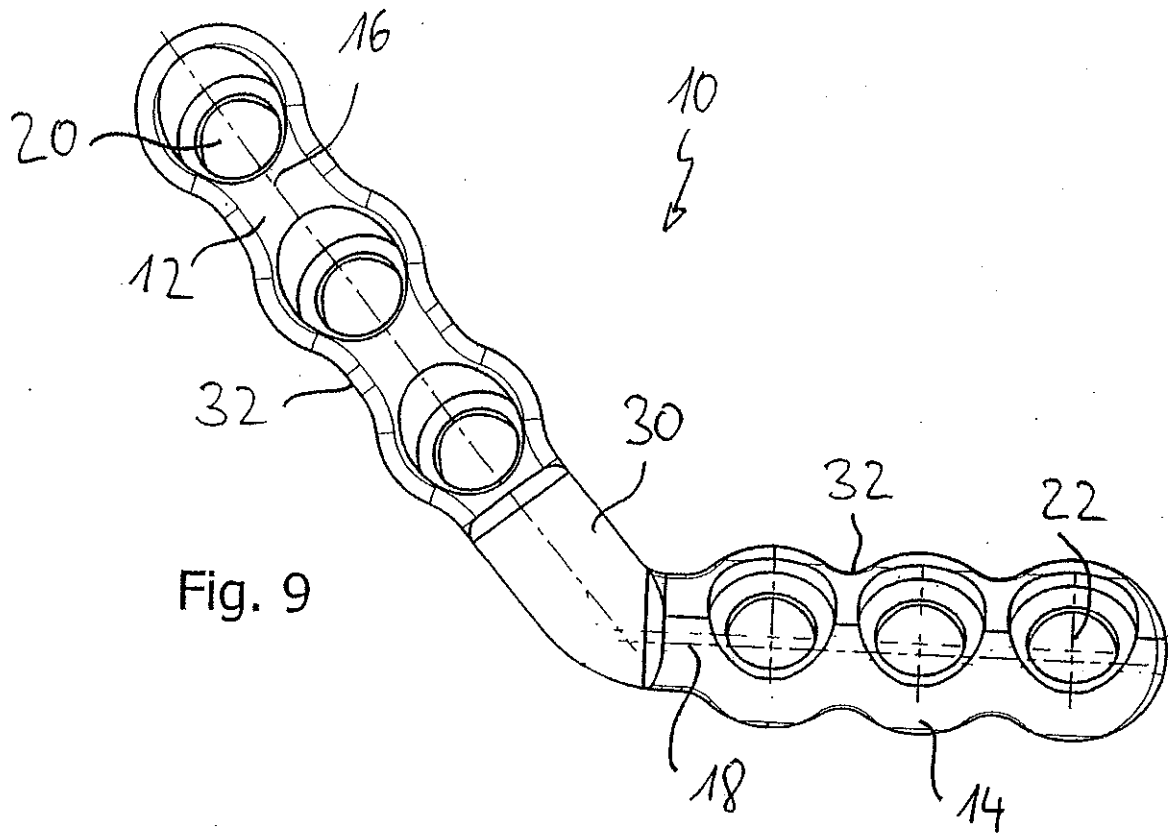

Fig. 8B



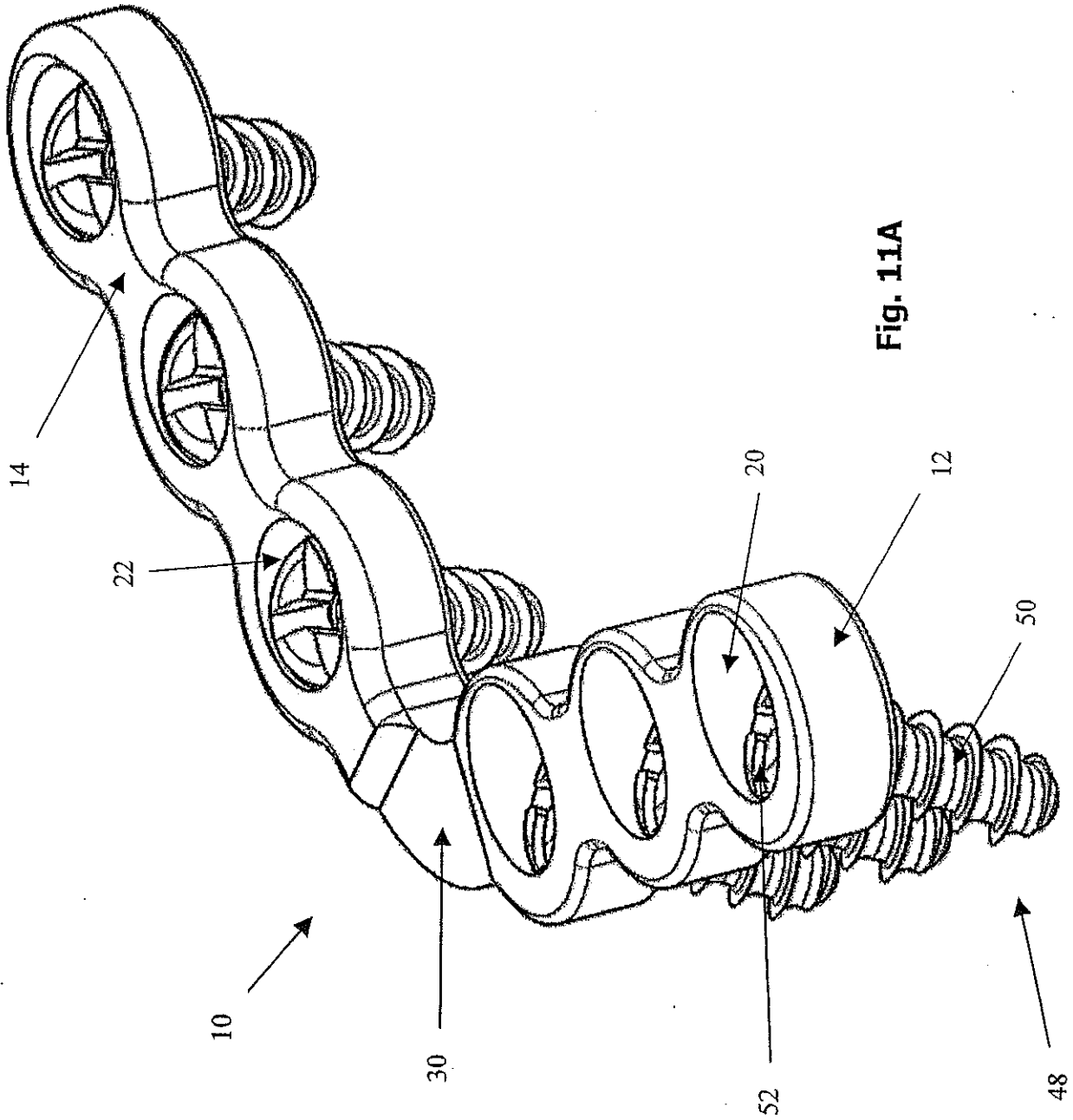

Fig. 11A

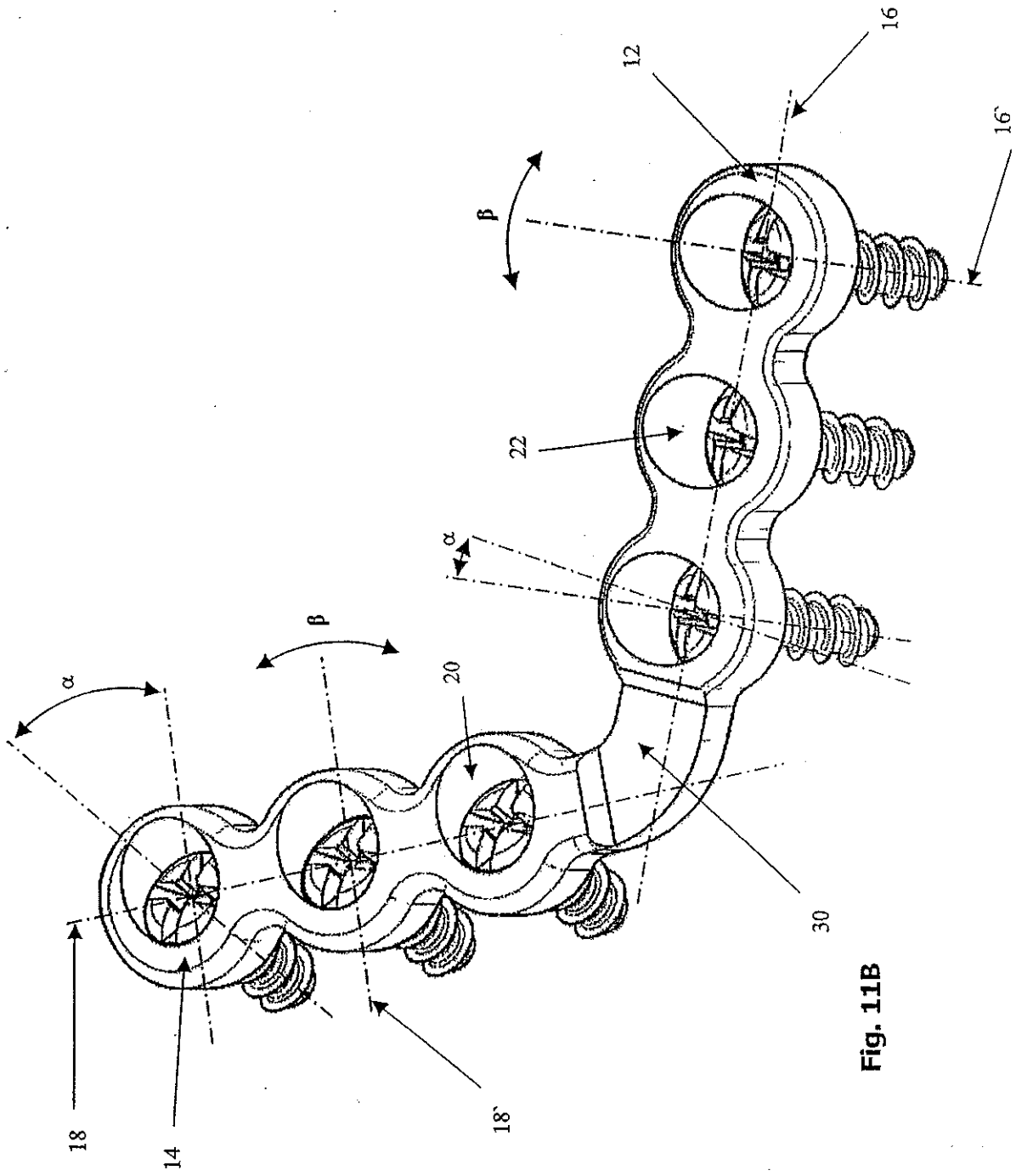

Fig. 11B

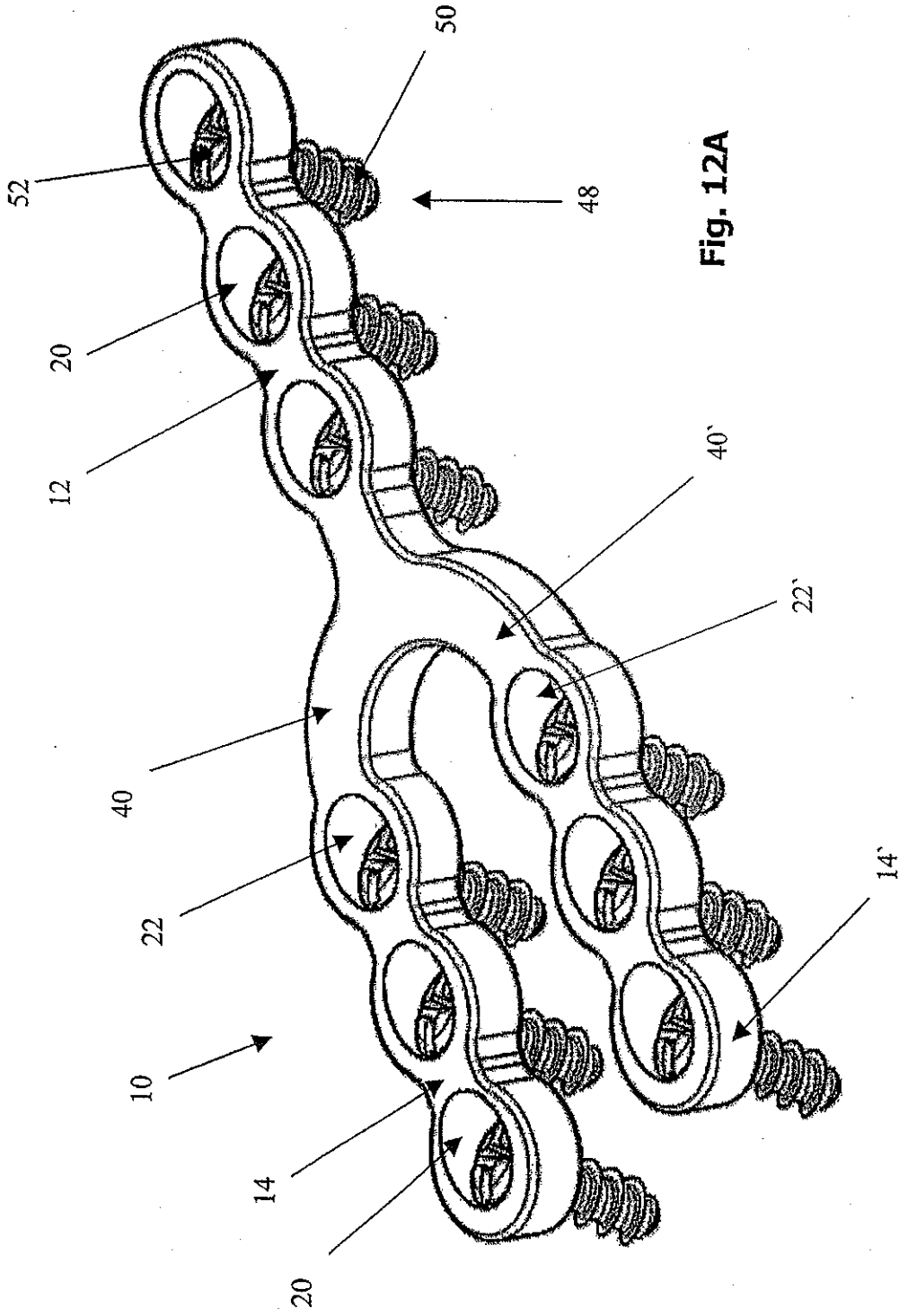

Fig. 12A

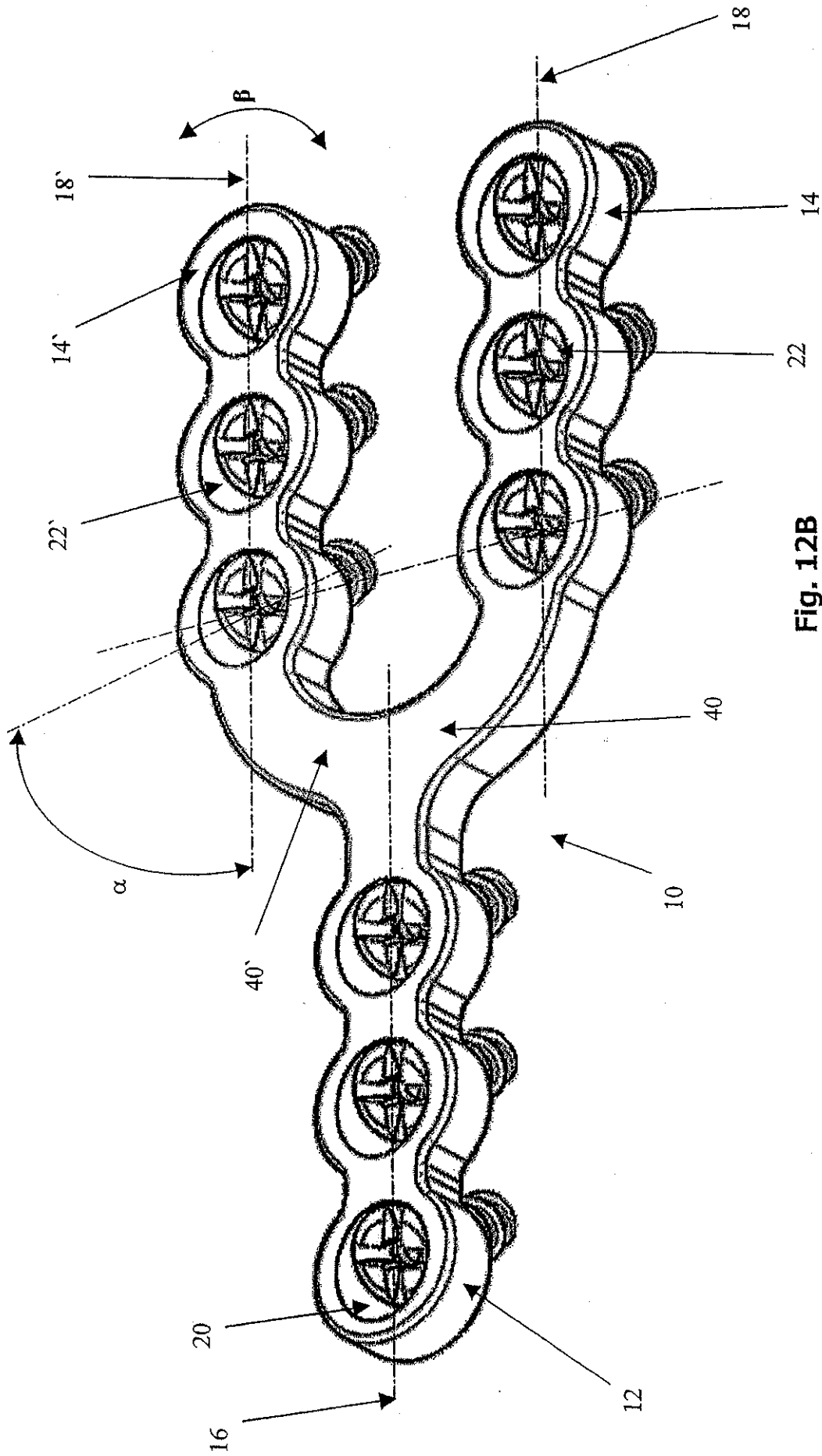
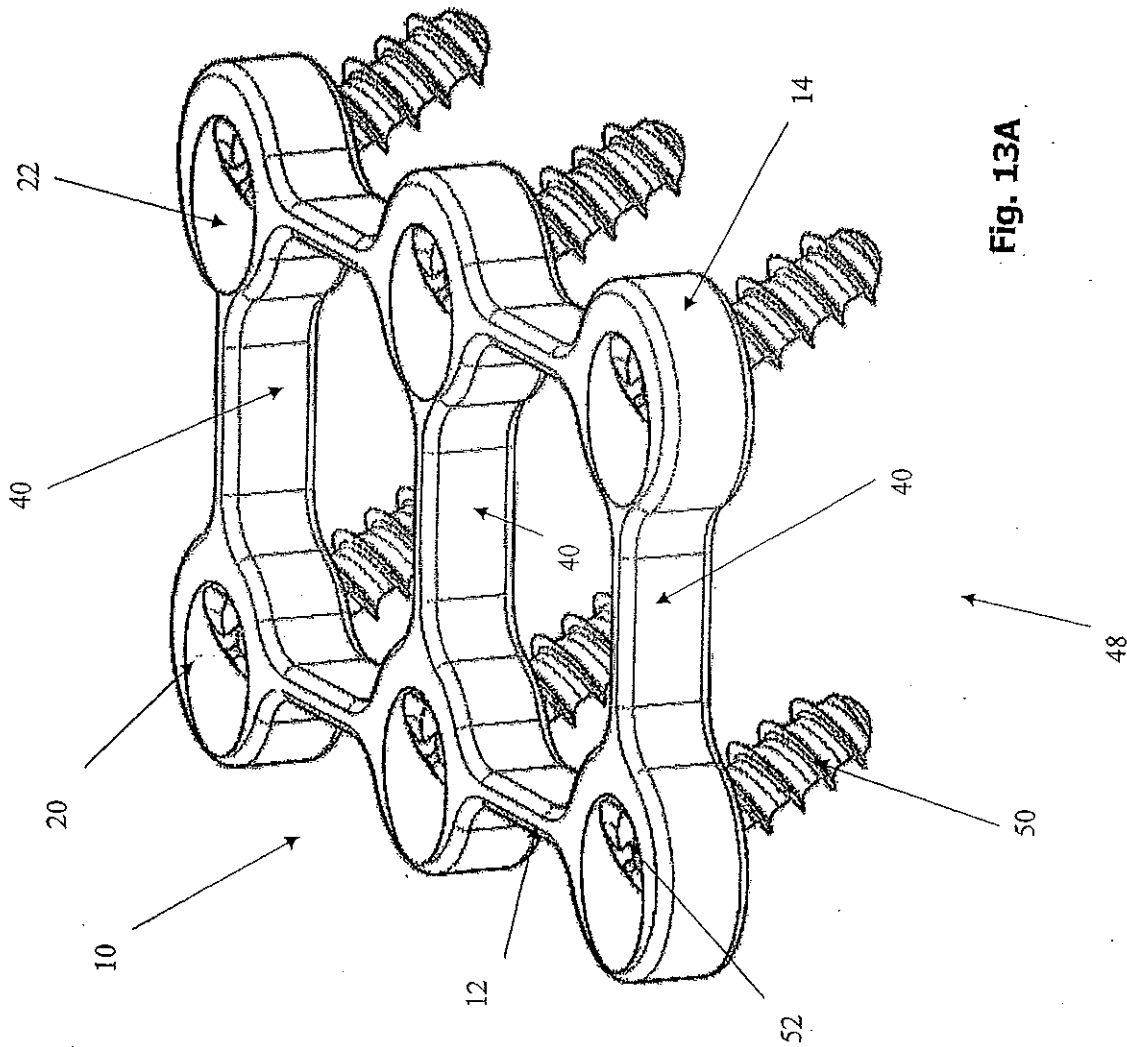

Fig. 12B



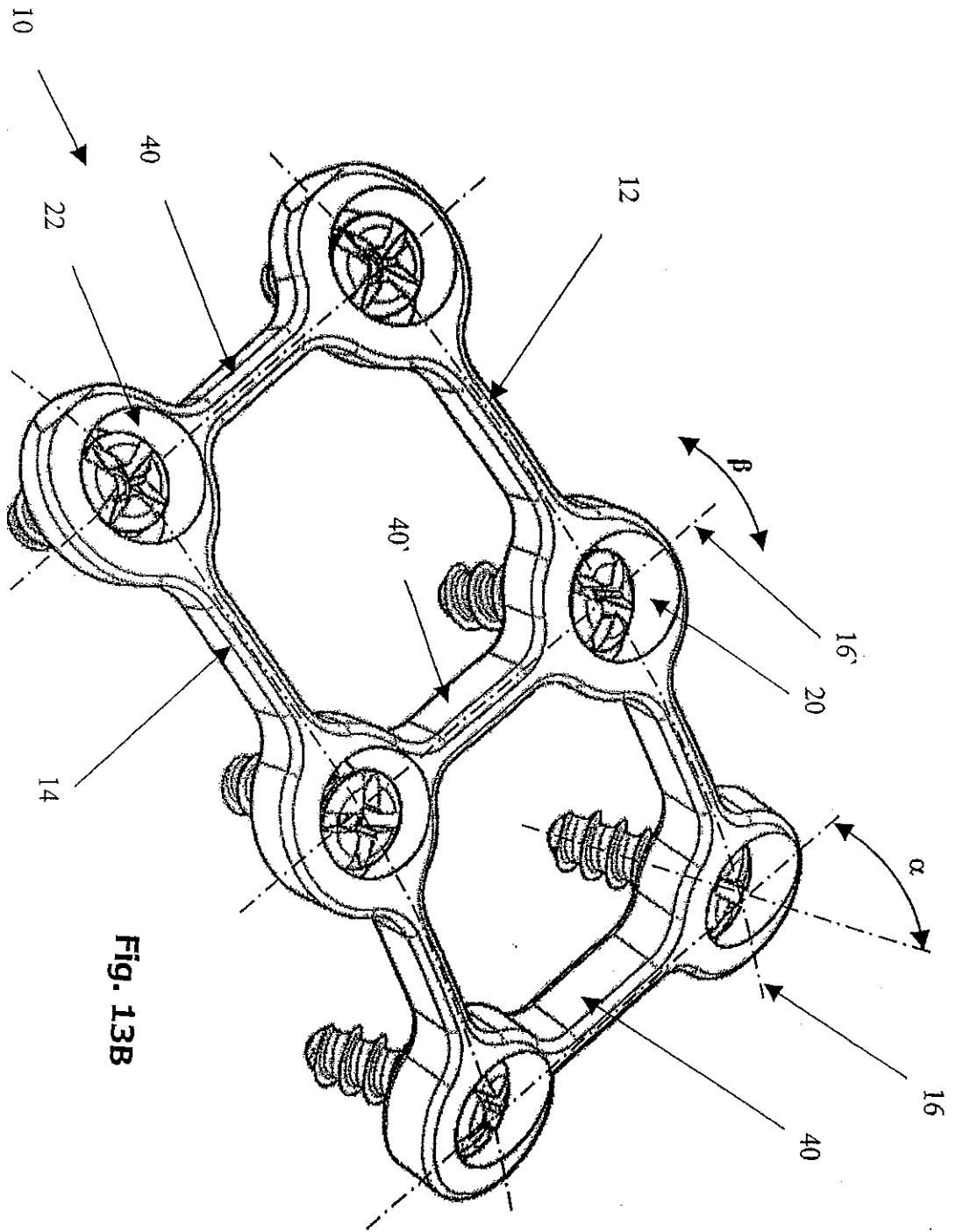

Fig. 13B

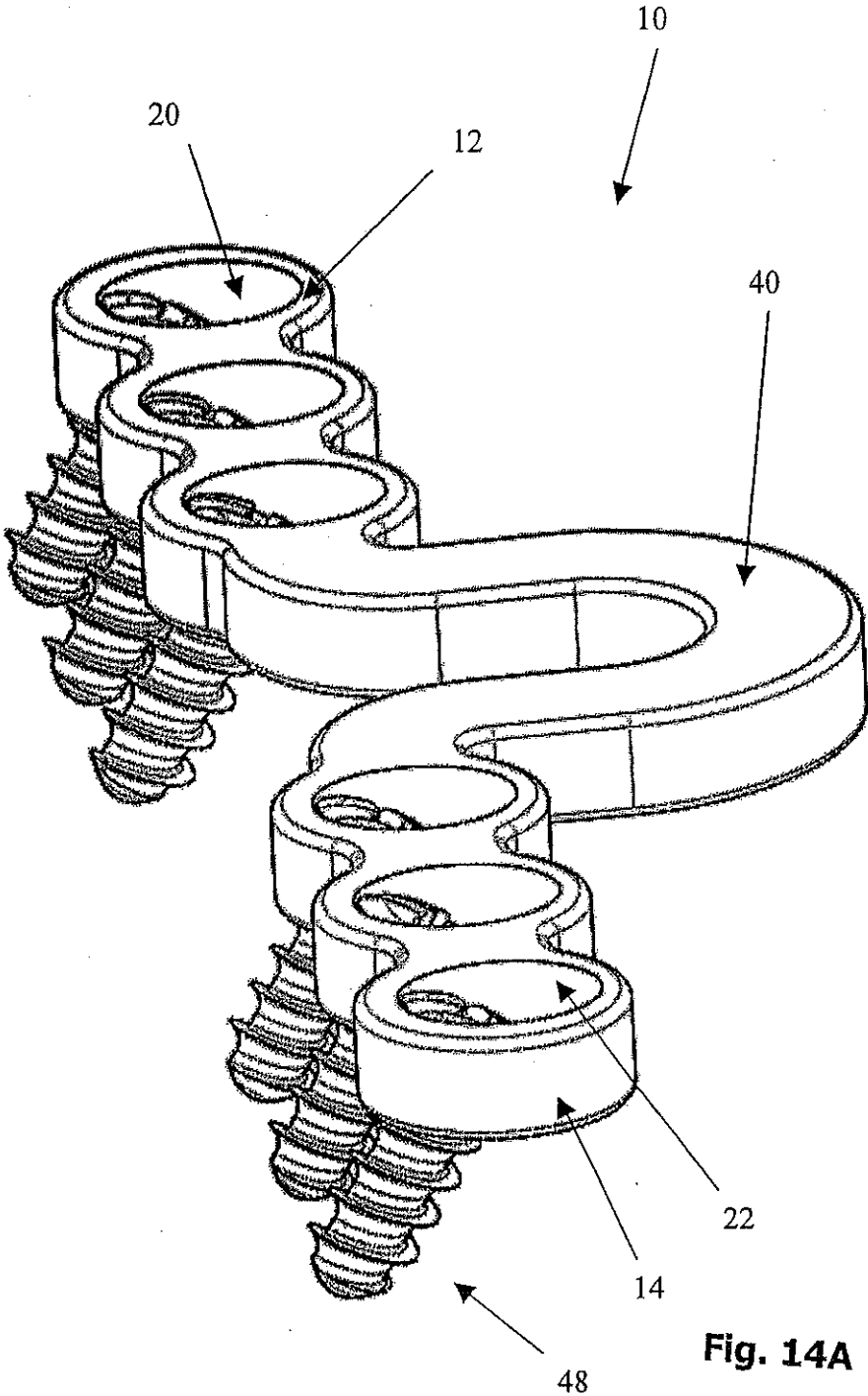
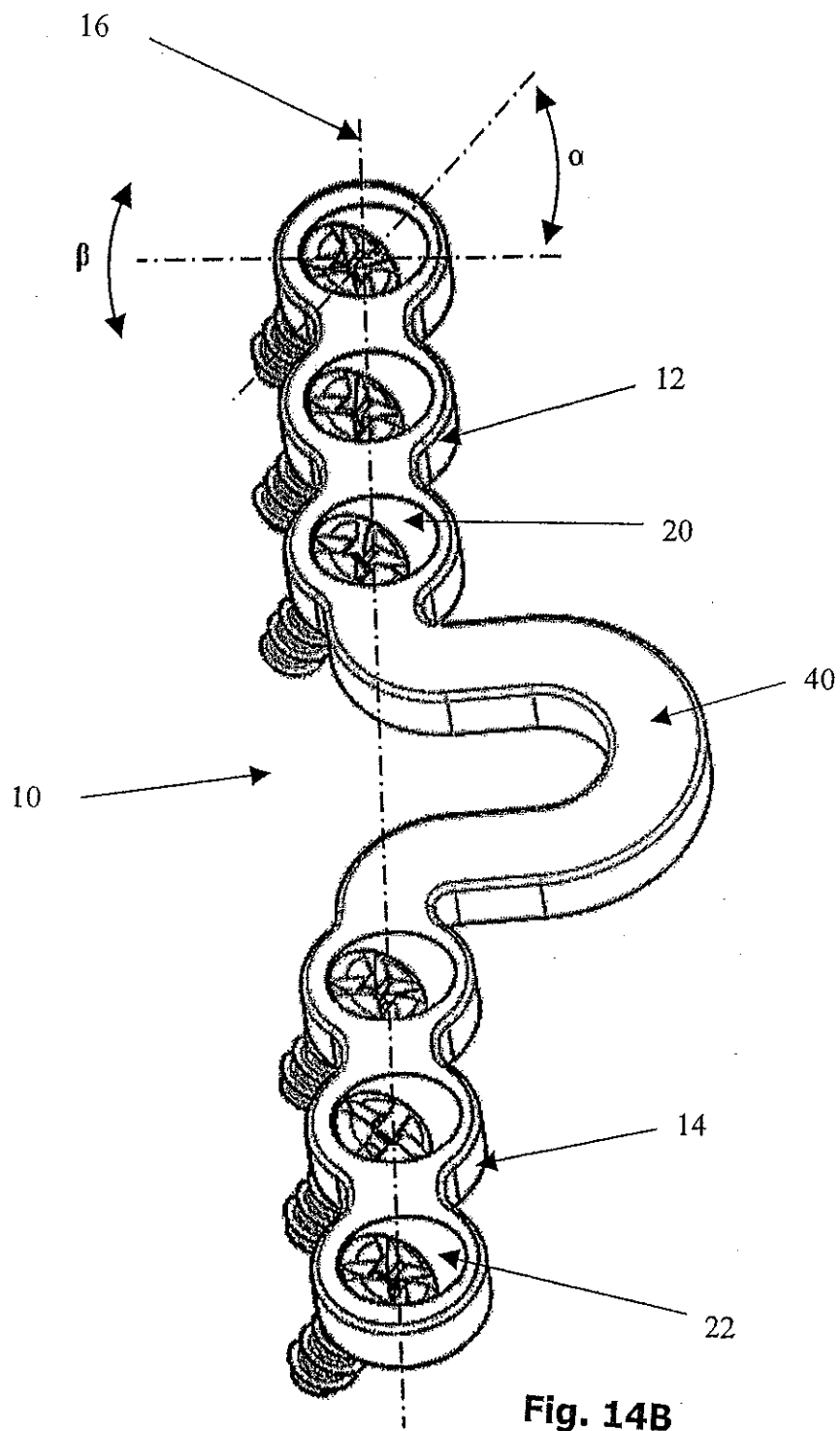

Fig. 14A



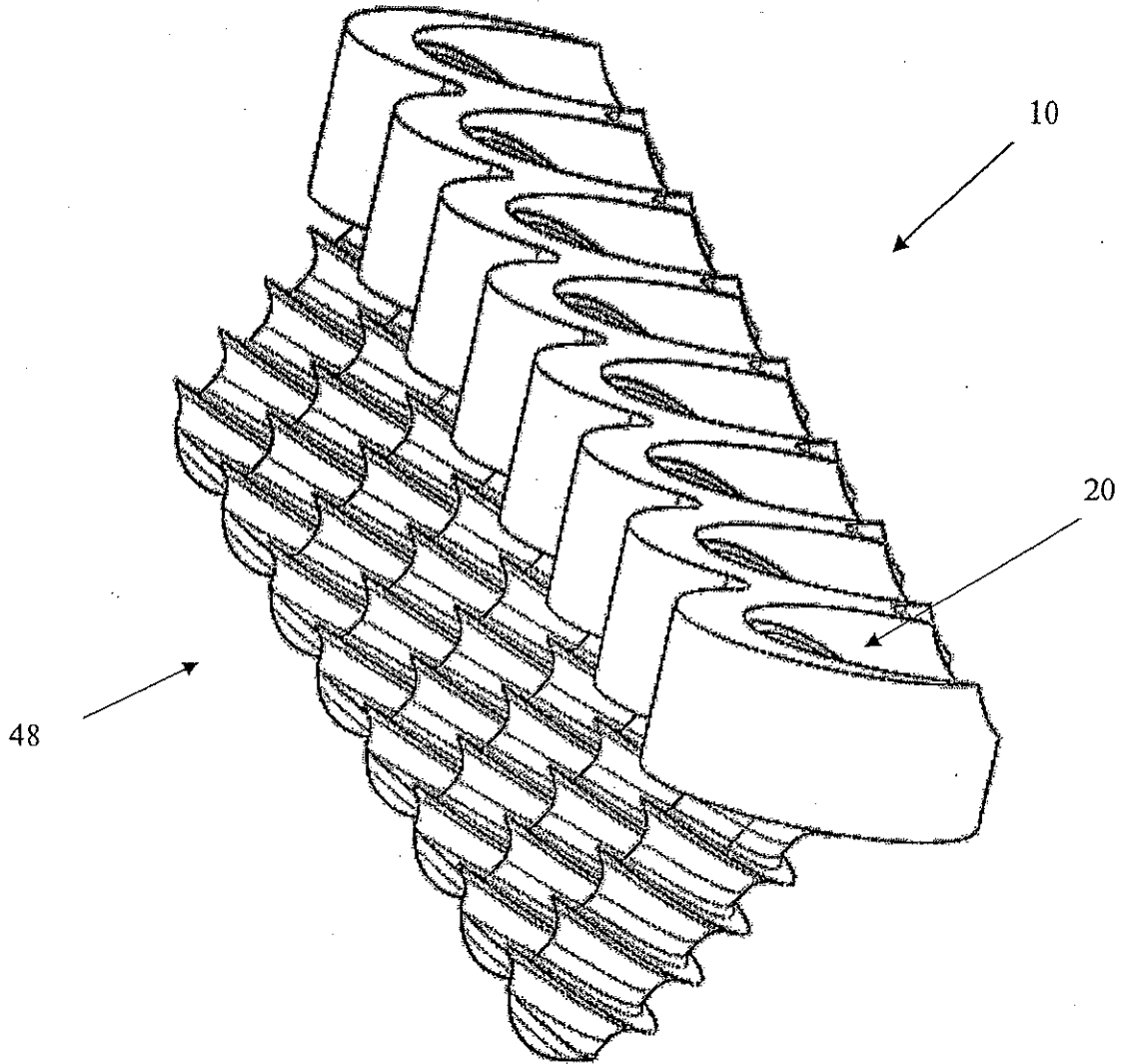

Fig. 15A

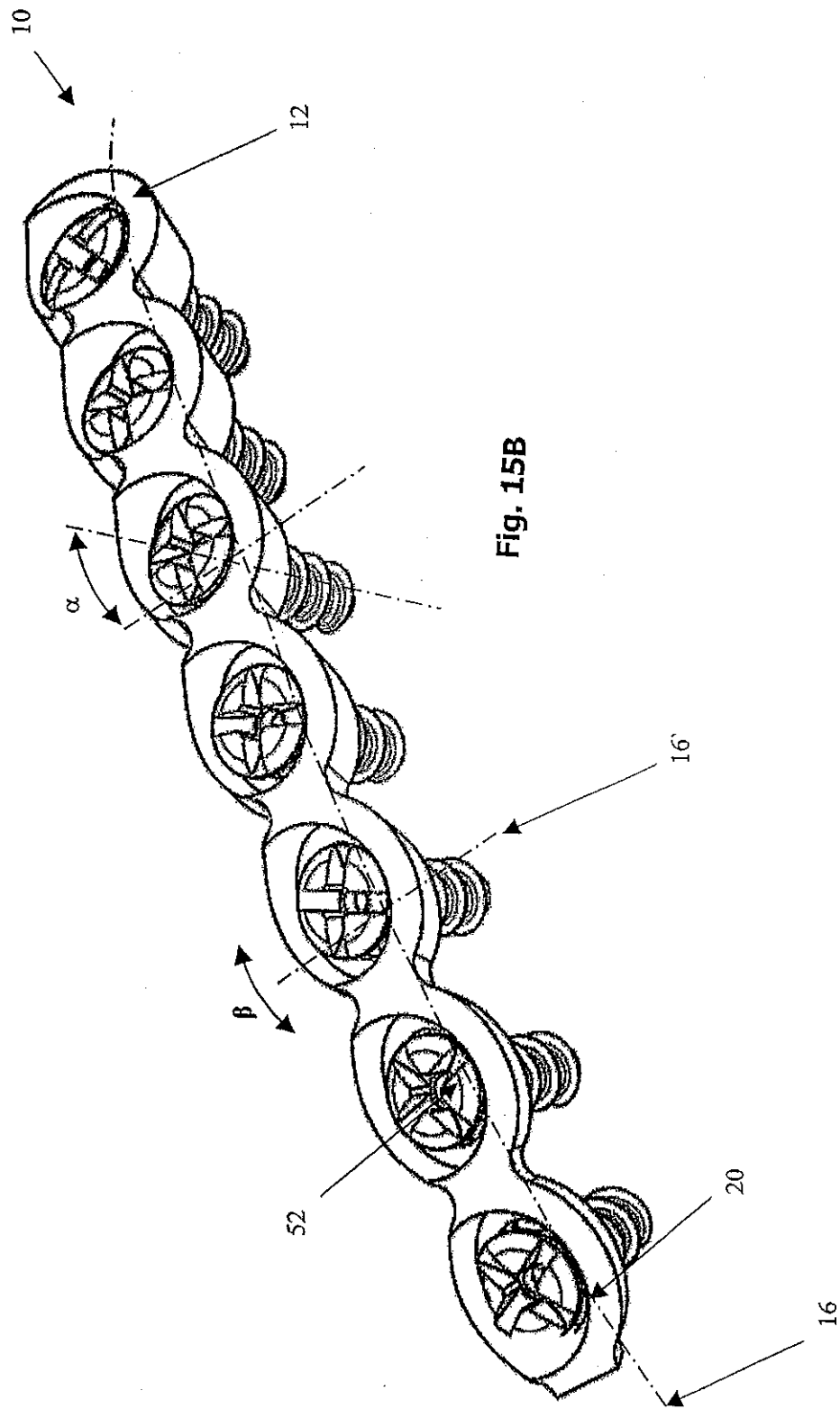

Fig. 15B

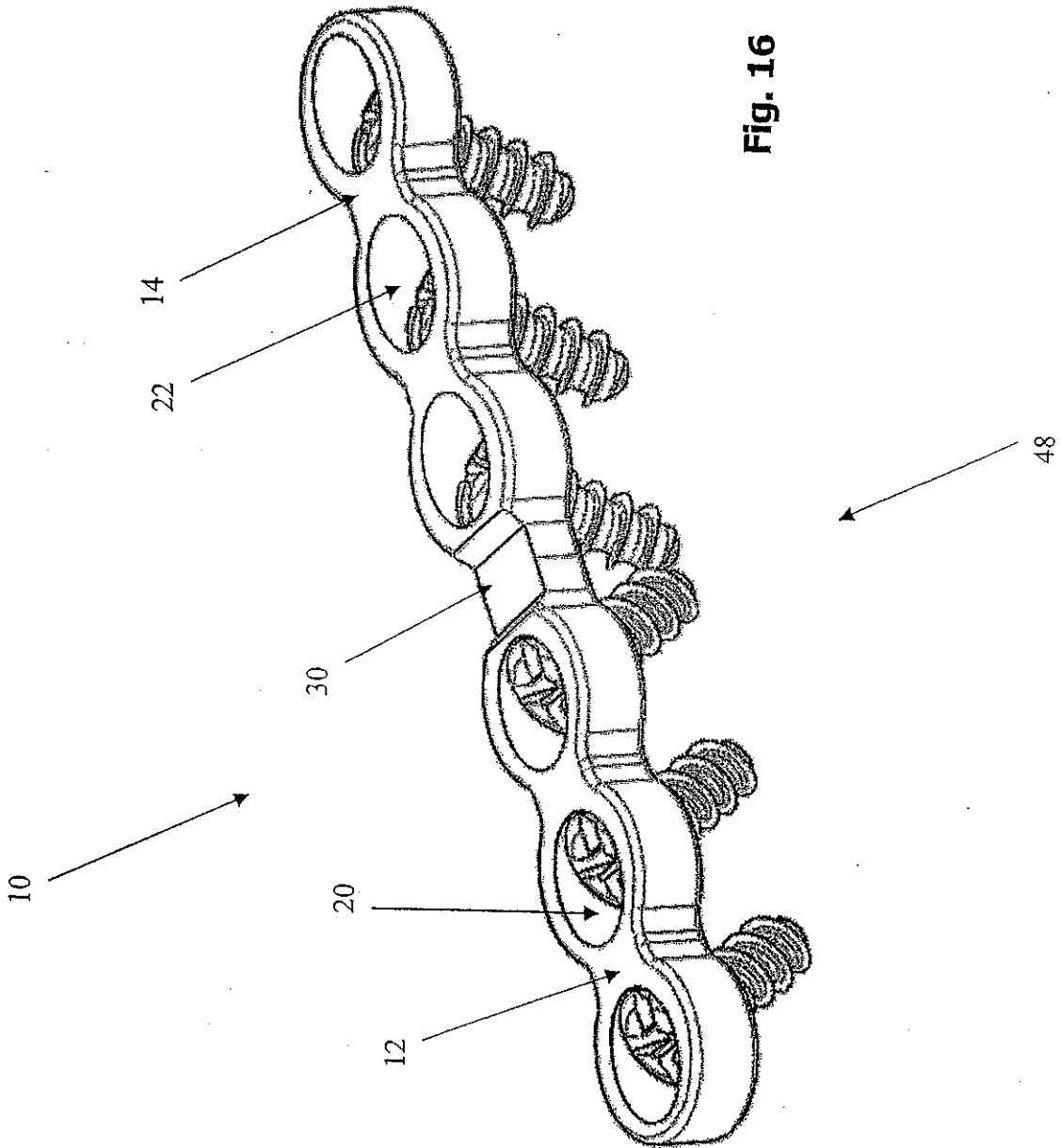

Fig. 16

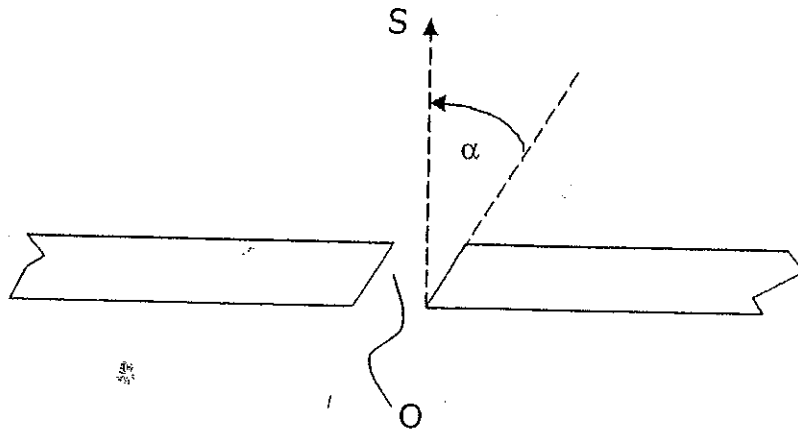

Fig. 17

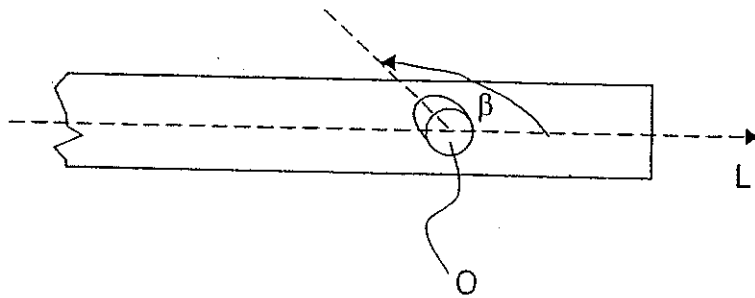

Fig. 18

**Amended claims under Art. 34 PCT**

- 5 1. Osteosynthesis plate (10), in particular for treating jaw fractures, with
- a plane of the plate;
 - a linear first section (12) with a first longitudinal axis (16) and extending substantially within the plane of the plate;
 - a linear second section (14) with a second longitudinal axis (18) and extending substantially within the plane of the plate and inclined to the first section (12);
 - at least one circular first through opening (20) in the first section (12), which is inclined to the plane of the plate and has with respect to the first longitudinal axis (16) a first angular orientation within the plane of the plate; and
 - at least one circular second through opening (22) in the second section (14), which is inclined to the plane of the plate and has with respect to the first longitudinal axis (16) of the first section (12) a second angular orientation within the plane of the plate, wherein the first and the second angular orientations differ with respect to the first longitudinal axis (16) from one another by less than about 60° , so that fastening elements (48) can be introduced into the through openings (20, 22) of both plate sections (12, 14) in a direction predetermined by a single access.
- 10
- 15
- 20
- 25 2. Osteosynthesis plate according to claim 1, characterised in that the first and the second angular orientations differ with respect to the first longitudinal axis (16) from one another by less than about 45° .
- 30 3. Osteosynthesis plate according to claim 1 or 2, characterised in that the first angular orientation is inclined to the first longitudinal axis (16) and/or the second angular orientation is inclined to the second longitudinal axis (18).
- 35 4. Osteosynthesis plate according to one of claims 1 to 3, characterised in that the at least one first through opening (20) intersects the plane of the plate at an angle of approximately 20° to 80° .



5. Osteosynthesis plate according to one of claims 1 to 4, characterised in that the at least one second through opening (22) intersects the plane of the plate at an angle of approximately 20° to 80° .
- 5 6. Osteosynthesis plate according to one of claims 1 to 5, characterised in that the first angular orientation with respect to the first longitudinal axis (16) is between approximately $+90^{\circ}$ and -90° .
- 10 7. Osteosynthesis plate according to one of claims 1 to 6, characterised in that the second angular orientation with respect to the second longitudinal axis (18) is between approximately 60° and 180° .
- 15 8. Osteosynthesis plate according to one of claims 1 to 7, characterised in that the second angular orientation with respect to the second longitudinal axis (18) is between approximately 180° and 300° .
9. Osteosynthesis plate according to one of claims 1 to 8, characterised in that the first section (12) and the second section (14) directly adjoin one another.
- 20 10. Osteosynthesis plate according to one of claims 1 to 9, characterised in that the first section (12) has an angle of approximately 90° to 160° with respect to the second section (14).
- 25 11. Osteosynthesis plate according to one of claims 1 to 10, characterised in that the osteosynthesis plate (10) comprises at least one bending region (30, 32, 40) of reduced plate thickness and/or of reduced plate width and/or of meandering shape.
- 30 12. Osteosynthesis plate according to one of claims 1 to 11, characterised in that the first section (12) has a length between approximately 5 and 70 mm and/or the second section (14) has a length between approximately 5 and 70 mm.
- 35 13. Osteosynthesis plate according to one of claims 1 to 12, characterised in that the osteosynthesis plate (10) in the region of the first section (12) and/or in the region of the second section (14) has a maximum plate thickness between approximately 0.5 and 3.5 mm.



- 5
- 10
14. Osteosynthesis plate according to one of claims 1 to 13, characterised in that the at least one first through opening (20) and/or the at least one second through opening (22) has underneath a plate surface (28) a stop means (26) for a head of a fastening element.
 15. Osteosynthesis plate according to one of claims 1 to 14, characterised in that a plurality of first through openings (20) and/or a plurality of second through openings (22) are provided.