

# CHAPTER 4

---

## DEVELOPMENT TESTS

---

### 4.1 Introduction

This chapter will cover the development tests that were done regarding the production of the master punch and coining dies. The test objectives will be discussed for each test as well as the procedure that was followed in conducting the tests.

The procedure that was followed, during this project to produce the coining dies is summarized below. The reader is referred to *Section A. Die development*, for a complete discussion about the die development process.

1. Generate computer model.
2. Machine matrix on CNC Engraver.
3. Machine relief into matrix.
4. Harden matrix.
5. Hob matrix on die blank to produce master punch.
6. Machine master to specifications.
7. Harden master.
8. Hob master on die blank to produce coining dies.
9. Machine coining dies to specification.
10. Harden coining dies.

There are various factors affecting the accuracy and quality of the dies and punches that are produced during this process. During the development tests these factors, which affect the accuracy and quality of the dies, will be identified and isolated. The effect of these factors will be quantified and discussed.

The major concern during the development process is the dimensional stability of the dies. The problem that faces the developer is that he often knows what the coining dies should look like but he has difficulty producing the coining dies according to his requirements.

To improve coinage a slight dome of about 50 microns is created on the coining dies. This dome ensures that the blanks start coining in the centre and coining then progress coining radially outward. The effect of the dome is that the force required to sufficiently coin the blanks is reduced. This improves die life. It is very important to determine the correct dome size. If the dome is too small, the centre design will not coin satisfactorily. If the dome is too large, the lettering on the outside of the design will not coin satisfactorily. Once the ideal dome size has been determined it must be reproduced on the coining dies. The way in which this is done, is by modeling a dome on a computer or by placing the rubber mould on a dome plate before the ureol is cast.

The problem lies therein that the dome does not reproduce accurately due to the dimensional change that occurs during the manufacturing process. These and other dimensional stability problems will receive attention during the development tests.

## **4.2 Test 1: Introduction to Development Tests**

The purpose of the initial test was first and foremost to establish a detailed test protocol for the project tests. This was seen as a trial of the tests to come. The test was also used, as a guideline for what Test 2 should entail. The test was done to familiarize the candidate with the development process and the equipment that is used in the process.

It was decided that for this project no machine punch would be made. The process will start with the modeling of the design on computer. A matrix will then be engraved on the CNC engraving machine. This eliminates the process of creating a machine punch on the reduction machines. This saves a lot of time since the reduction from the ureol to the machine punch can take weeks. It is also more accurate to model the design on the computer and changes can easily be made if necessary. The use of the CNC engraver to create the matrix is gaining more popularity due to the significant reduction in development time and effort. New computer hardware and software technologies make this a very attractive means of creating the matrix.

The test procedure for test 1 was as follows.

1. The selected design was modeled on the computer (Appendix C).
2. A matrix was engraved and sent for heat treatment.
3. A master punch was hobbled from the hardened matrix.
4. The master punch was measured and then sent for heat treatment.
5. The master punch was again measured after heat treatment.

From the results of Test 1 it became evident that the measuring procedure is extremely important and that the dies and punches must be measured with an accuracy of a few microns. The candidate was not familiar with the measuring equipment and accurate results could not be guaranteed. It was necessary to establish a measuring procedure that would be followed every time something was measured. This had to be done before test 2 could commence.

The hobbing press had to be calibrated since a lot of work will be done on the press and the applied force is an important factor in all the tests. A calibration certificate for the digital readout gauge on the press was not available.

The main complications encountered during the process are the dimensional instability of the dies during the heat treatment process and the elastic recovery of the material during the forming process. These problems will be addressed in the subsequent tests.

Due to the irregular deformation that was observed, it was decided that the heat treatment and the hobbing processes should be separated for the next test. The effect of the heat treatment process can then be quantified properly without the additional effects of plastic deformation.

No formal results were documented for test 1 due to the lack of reliability of the results. The test protocol for the subsequent tests has been generated as an output. All problems regarding the test protocol have been sorted out.

## 4.3 Calibration Of Hobbing Press

### 4.3.1 PURPOSE

The hobbing press is used to hob the master punches from the matrix. A lot of effort will be put into this process and the applied force was an important criterion in all the experiments that were conducted. It was therefore imperative that the calibration of the press be checked to ensure that the indicated applied force was correct.

The press under discussion is the Sack & Kiesselbach Oil Hydraulic Press. The press has a 630-Ton maximum force and a minimum pressing speed of 2 mm/s. The hydraulic press has the advantage that the nominal force is available over the entire pressing stroke. The press is shown in Figure 4.1. A digital readout gauge on the press provides a readout of the applied force.



**FIGURE 4.1 Sack & Kiesselbach Hobbing Press**

The objective of the test was to check the calibration of the digital readout gauge fixed to the press. The digital gauge will be compared to the loadcell up to a force of 50 tons. The digital gauge will then be compared to an oil pressure gauge, fixed to the press, using a much higher tonnage.



### 4.3.2 PROCEDURE

The hobbing press was calibrated using a 50-ton loadcell. This was the largest loadcell available that could fit into the press cavity. The Laboratory of Advanced Engineering calibrated the loadcell. The calibration factor of the loadcell was 500 kN = 10 V.

The loadcell was placed on the bed of the press. A 50 mm diameter, 40 mm long hardened billet was placed on top of the loadcell. Both surfaces of the billet were ground to ensure that the surfaces were parallel. Note was taken of the zero load error before pressure was applied. Load was applied to the billet until the reading on the loadcell increased with 1000 mV. The reading on the digital gauge was taken on each occasion.

### 4.3.3 RESULTS

The processed data is shown in Table 4.1 and presented graphically in Figure 4.2. The equation,  $y = 5.1082.x - 2.2497$  was used to fit a linear trendline through the data. The data follow a linear trend since the trendline passes through all the data points.

Loadcell [mV]	Digital Gauge
0	-2.8
1025	3.2
2010	8.2
3001	13.2
4000	18.4
5003	23.4
6000	28.4
7000	33.4
8000	38.6
9000	43.6
9960	48.6

TABLE 4.1

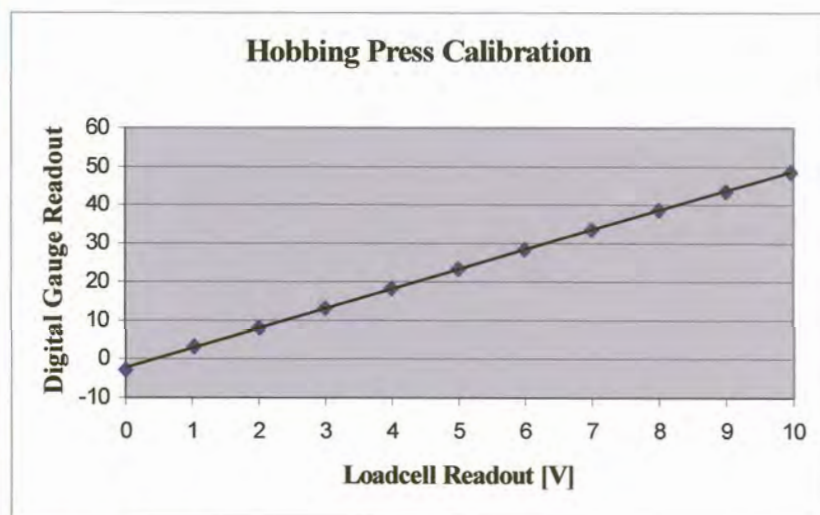


FIGURE 4.2

It is necessary to calculate the error between the actual tonnage and the reading given by the digital gauge. To determine the actual tonnage the reading from the loadcell must be converted from mV to tons. This was done using the calibration factor of the loadcell.

Calibration Factor of loadcell :  $1V = 50\text{ kN}$

$$\text{Loadcell kN} = \frac{\text{Loadcell mV}}{1000} \times 50 = \text{Applied Force [kN]}$$

$$\text{Applied Tonnage} = \frac{\text{Applied Force [kN]}}{a} ; \quad a, \text{ gravitational accel. equal to } 9.81 \text{ m/s}^2$$

The results are shown in Table 4.2. For each reading the actual tonnage and the digital reading are plotted. A graphical presentation of the results is shown in Figure 4.3. The difference between the actual load and the indicated load can now be calculated. The average difference calculated, can now be added to the digital reading to achieve greater accuracy. If the average difference is added to the digital reading the error is 0.07 % at 50 tons, which is extremely accurate. A quicker and more practical approach can be followed by subtracting the zero load reading, i.e -2.8 tons, from the digital reading. This produces an error of 1.25 % at a load of 50 tons. The percentage error will be much smaller at the working load of approximately 150 to 200 tons since the zero load error remains constant.

Example to calculate actual load:

$$\text{Digital readout} = 48.6$$

$$\text{Average difference} = 2.19$$

$$\text{Adjusted reading} = 48.6 + 2.19 = \mathbf{50.79}$$

$$\text{Actual load} = \mathbf{50.76}$$

$$\% \text{ Error} = 0.07$$

<i>Reading</i>	<i>Actual Load [Tons]</i>	<i>Digital Gauge Reading</i>	<i>Difference</i>	<i>% Error</i>
0	0	-2.8	2.80	
1	5.22	3.2	2.02	3.23
2	10.24	8.2	2.04	1.45
3	15.30	13.2	2.10	0.64
4	20.39	18.4	1.99	1.01
5	25.50	23.4	2.10	0.37
6	30.58	28.4	2.18	0.04
7	35.68	33.4	2.28	0.24
8	40.77	38.6	2.17	0.04
9	45.87	43.6	2.27	0.17
10	50.76	48.6	2.16	0.07
<i>Average</i>			<b>2.19</b>	

TABLE 4.2 Calculating the error of the digital readout gauge

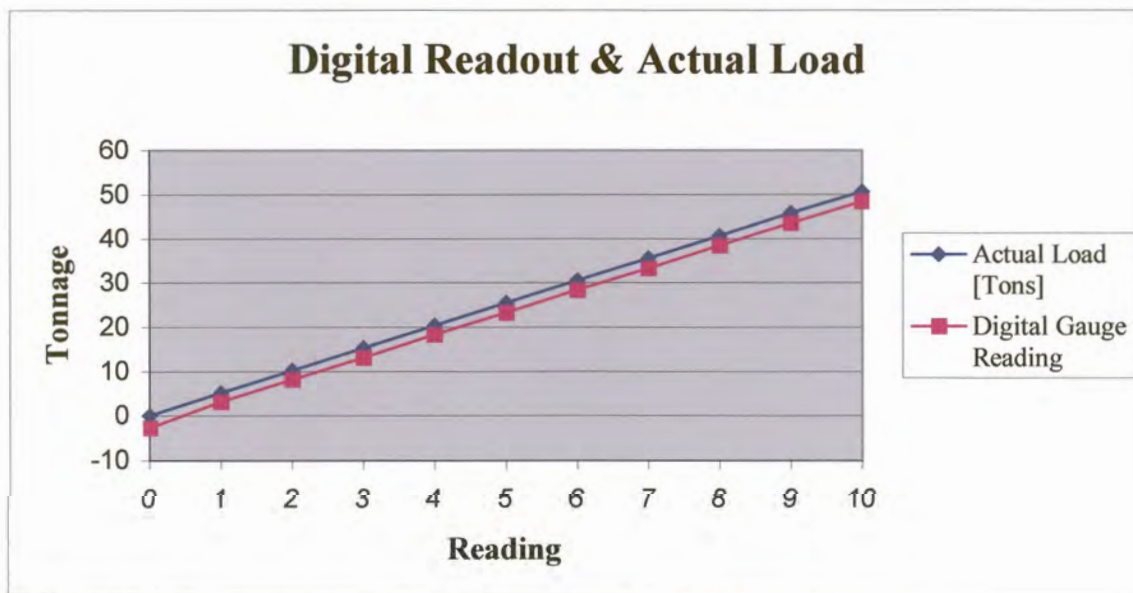


FIGURE 4.3 Comparison between actual load and indicated load



The next step is to check the accuracy of the digital gauge at increased loads. This will be done with the oil pressure gauge attached to the press. The pressure gauge has been calibrated by the installer and provides an accurate reading of the oil pressure. The load was gradually increased in increments of 1 MPa. Each time the digital readout was taken. Slight errors can occur during the reading of the analog pressure gauge and therefore the test was repeated to obtain two sets of data. The results are shown in Table 4.3.

	1st Set	2nd Set
<i>Pressure Gauge</i> [MPa]	<i>Digital Gauge</i> [MPa]	<i>Digital Gauge</i> [MPa]
1	12	11
2	22	22
3	37	37
4	48	49
5	64	64
6	78	77
7	90	90
8	102	101
9	114	114
10	130	128
11	140	141
12	154	152
13	164	165
14	177	177
15	190	189
16	202	202

**TABLE 4.3 High Load Calibration**

The two sets of data were plotted against pressure. The results are shown in Figure 4.4. The following equation,  $y = 12.769x - 1.1$  was used to fit a linear trendline through the data. The linear behavior of the digital gauge is evident since the trendline passes through all the data points.

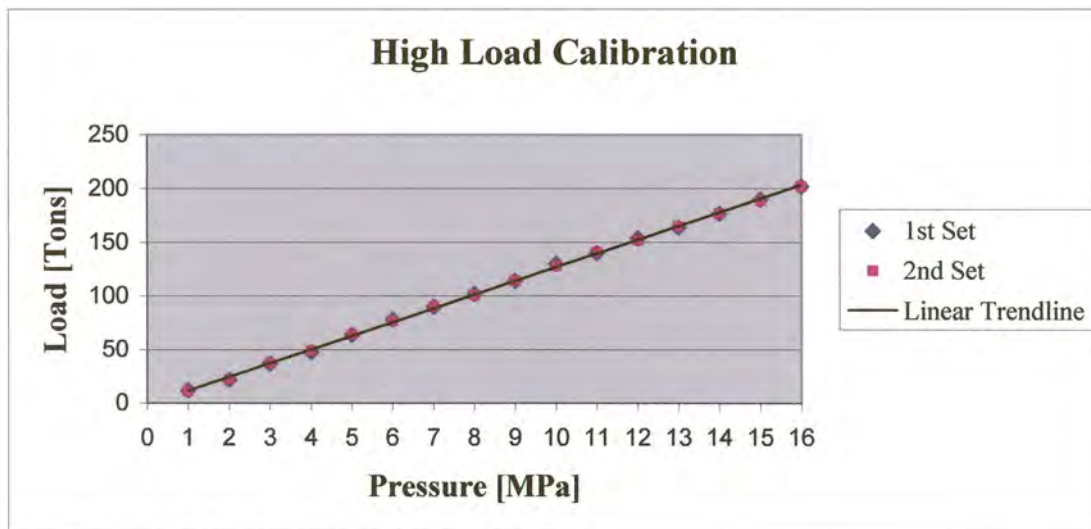


FIGURE 4.4 High load calibration

#### 4.3.4 CONCLUSION

The results of the test showed that the digital gauge gives very accurate readings of the applied force up to 200 tons. The actual applied tonnage will be taken as the digital reading minus the zero load reading. This will give a reading with more than adequate accuracy.

**Example :**

*Digital readout = 180*

*Zero load reading = -2.8*

*Actual applied load = 180 - (- 2.8) = 182.8 tons.*

## 4.4 Measuring Procedure

### 4.4.1 PURPOSE

It was necessary to establish a measuring procedure by which all measurements would be taken. It was noted during Test 1 that the measuring procedure is of great importance and accurate results are essential to the project. The measuring equipment that is used at the S.A Mint is very sophisticated and most of the measurements that will be taken must be accurate within a few microns. With accurate measurements one can better evaluate the response of the material. Therefore the candidate spent a lot of time familiarizing himself with the measuring equipment and the environment.

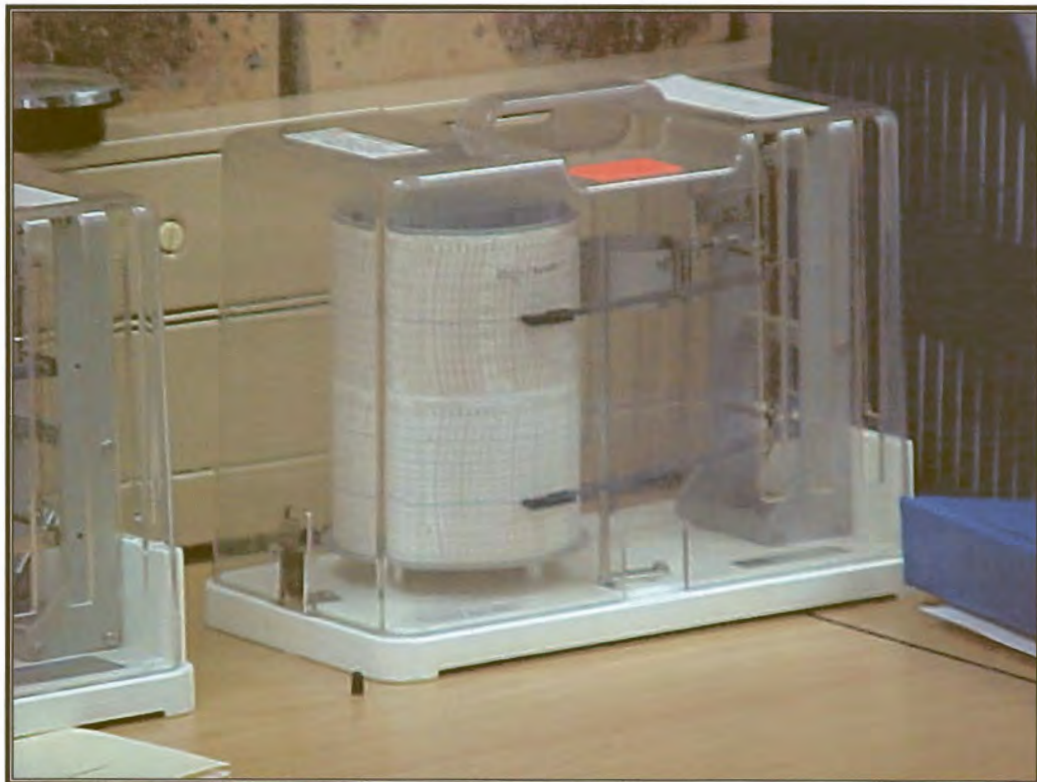
The linear height meter (LHM) is the most sensitive piece of equipment will be used. It is capable of giving a measurement accurate to 1 micron. This instrument will be used extensively during the project and it was therefore necessary for the candidate to do a qualification on the height meter. The calibration certificates were obtained for all the measuring equipment that was used during the project. The linear height meter is shown in Figure 4.5.



FIGURE 4.5 Linear Height Meter



The temperature and humidity of the metrology room where all the measurements are taken are controlled at all times. The temperature is held at a constant  $20^{\circ} \pm 1^{\circ}\text{C}$ . The humidity is held at 50 %. A Lambrecht Hydrograph controls the temperature and humidity of the room. The hydrograph is shown in Figure 4.6. A control chart for the hydrograph is shown in Appendix E. Before any measurements are taken the hydrograph is checked to ensure that the room is at the right temperature and humidity.



**FIGURE 4.6** Hydrograph measuring temperature and humidity.

#### 4.4.2 PROCEDURE

The procedure that was followed during the qualification will now be discussed.

1. Ensure that all equipment is clean, oil free and stabilized at  $20^{\circ}\text{C}$ . This includes the measuring table, the LHM and the object that will be measured. Prevent contact with measuring surface of the object.



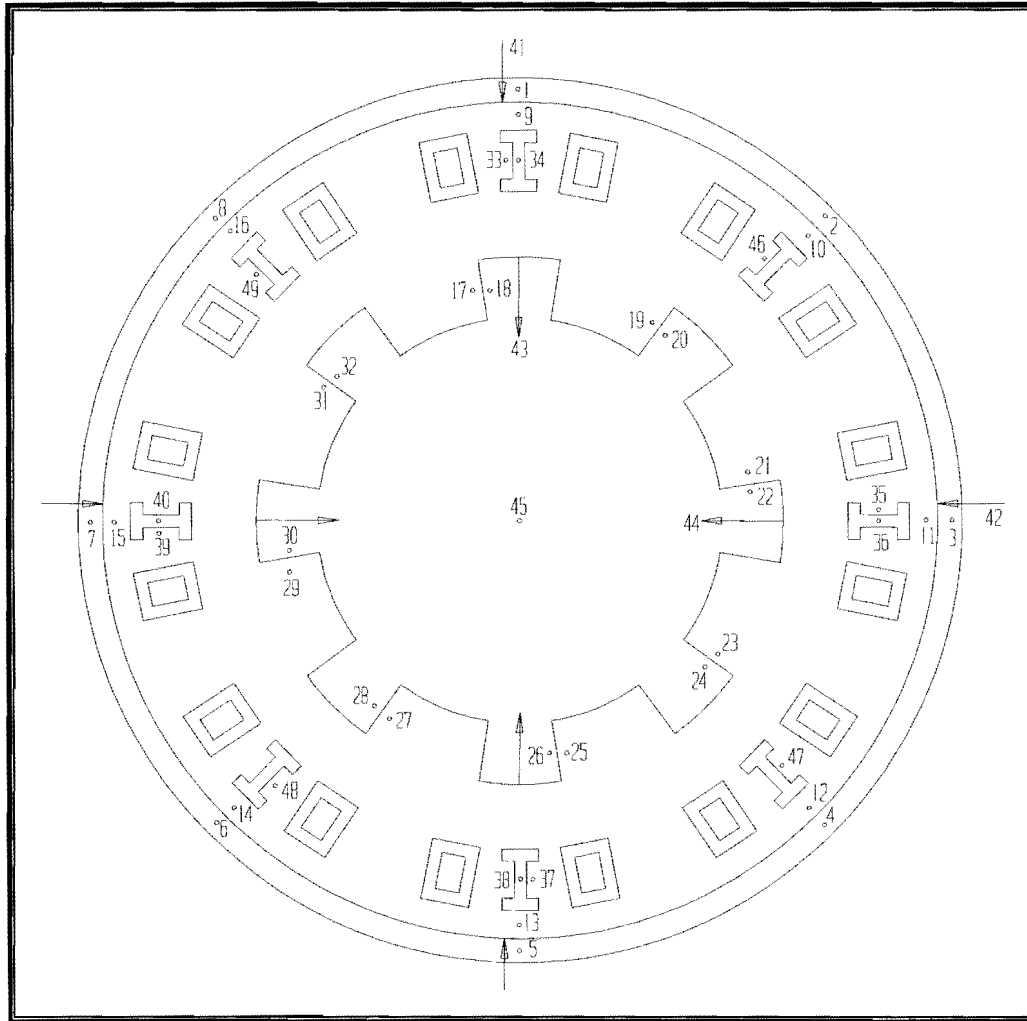
2. For the qualification a 50 mm steel slip gauge was measured.
3. Calibrate LHM.
4. Prepare to take measurements. Slide object on measuring table to remove air between the object and the measuring table.
5. Zero stylus on the measuring table surface.
6. Cover digital readout so that the candidate cannot observe the readings.
7. Take 5 consecutive measurements.
8. Repeat twice.
9. Switch LHM off and stand up.
10. Repeat steps 3 to 9, five times.

#### **4.4.3 RESULTS**

The results of the qualification are given in Appendix E. The results obtained were very encouraging. The average range that was achieved is 1.4 microns. The measurements lie in a very narrow band close to the actual size of the slip gauge. The total test accuracy is smaller than a micron. It is evident that the candidate is conversant with the equipment and the process. Reliable results can be guaranteed.

#### **4.4.4 CONCLUSION**

A chart was developed according to which all dies will be measured. This chart indicates the positions where the die should be measured to obtain sufficient information about the die. The chart is shown below in Figure 4.7



**FIGURE 4.7 Die Measuring Chart**

This chart will be used in future when measuring a die. Every die that is made for a test is given a clear reference point. This reference point indicates where to start the measuring procedure. The dies are placed in the metrology room to stabilize, 4 hours prior to the measuring procedure.

A Tolerance was calculated for the accuracy with which a measurement can be taken. The surface of the dies is uneven and the exact location of the measuring points is difficult to determine. Therefore, three measurements will be taken on each location and an average will be calculated. Considering all factors the accuracy tolerance of all the measurements taken on the LHM will be  $\pm 4$  microns.

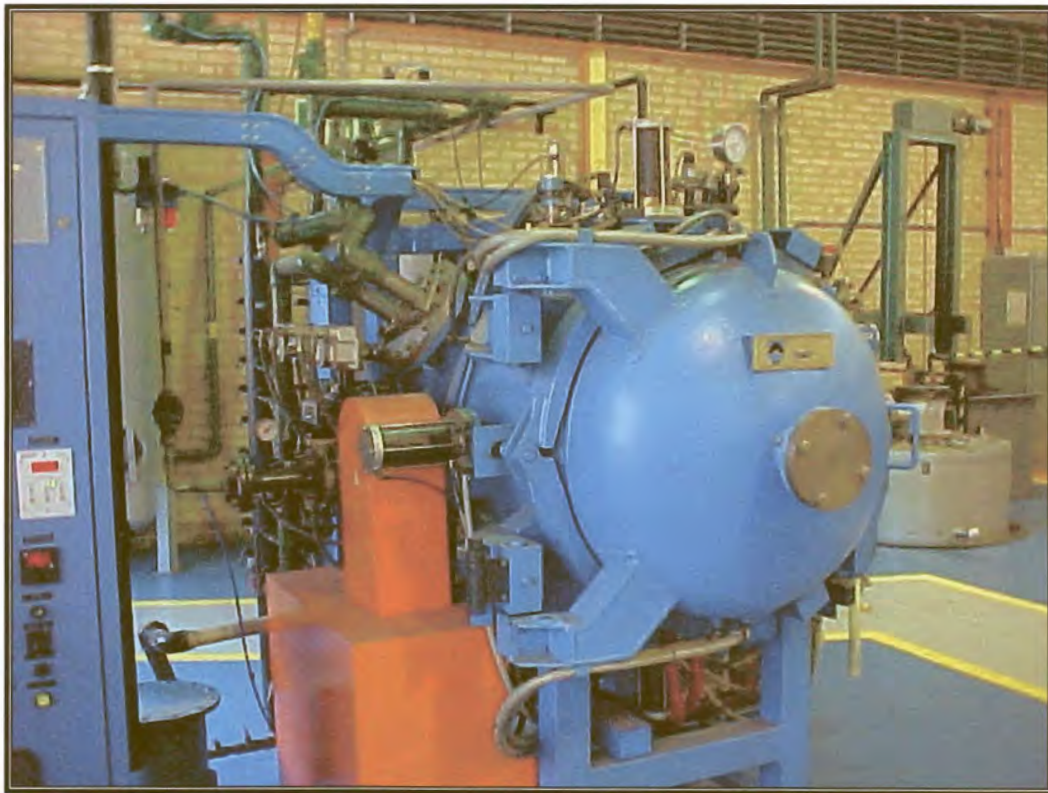
## **4.5 Heat Treatment**

All the dies and punches are heat treated before they are used as a hob in the hobbing and coining operations. The dies and punches are hardened to increase the strength of the material. An increase in hardness implies an increase in the yield strength of the material but also a decrease in the ductility of the material.

A sophisticated heat treatment furnace is used at the S.A Mint. The furnace temperature and holding times are controlled electronically to ensure accurate repeatability of the process. The material is heat treated in a nitrogen rich atmosphere to reduce the diffusion of carbon to the surface of the material. The furnace is shown in Figure 4.8(a). The material is heated slowly to above the austenitic temperature (970°C). This is done in three steps. The material is allowed to stabilize at each temperature before it is heated further, this ensures homogenous transformation to the austenite condition. The material is held at 970°C for 60 minutes before it is air quenched in an inert gas atmosphere using nitrogen. The nitrogen enters the back of the furnace, it is circulated through the furnace and exits at the top of the furnace.

Air quenching provides higher dimensional stability of the material during cooling and reduces the risk of cracking the dies. This is partly due to the reduction in thermal stresses that are induced on the die during cooling. The material is air quenched to produce a martensite structure. The martensite microstructure is extremely hard and the strength increases. The material also becomes more brittle. The quenching rate controls the hardness of the material. A faster quenching rate produces a harder material. This is mainly due to the increase in dislocation density of the martensite structure.

After the material has been cooled to room temperature it is tempered to make it softer and more ductile. This is done at a temperature below the eutectoid transformation temperature. During tempering the dislocation density is reduced and the material becomes softer. The final hardness of the material is dependent on the temper temperature. The hardness is specified before heat treatment and the temper temperature is then adjusted accordingly. The material specification in Appendix A shows a graph of hardness vs. temper temperature.



**FIGURE 4.8(a) Heat Treatment Furnace**

The details of a typical heat treatment process are shown below and are presented graphically in Figure 4.8(b). The effects of the heat treatment process on the punches and dies will be discussed during the development tests.



The Heat treatment process:

*Hardening:*

Heat:	20°C → 650 °C	Time: 65 min
Constant:	650°C	Time: 30 min
Heat:	650°C → 850°C	Time: 20 min
Constant:	850°C	Time: 30 min
Heat:	850°C → 970°C	Time: 18 min
Constant:	970°C	Time: 60 min
Quench:	970°C → 20°C	Time: 30 min

*Tempering:*

Heat:	20°C → 240°C	Time: 40 min
Constant:	240°C	Time: 120 min
Quench:	240°C → 20°C	Time: 30 min

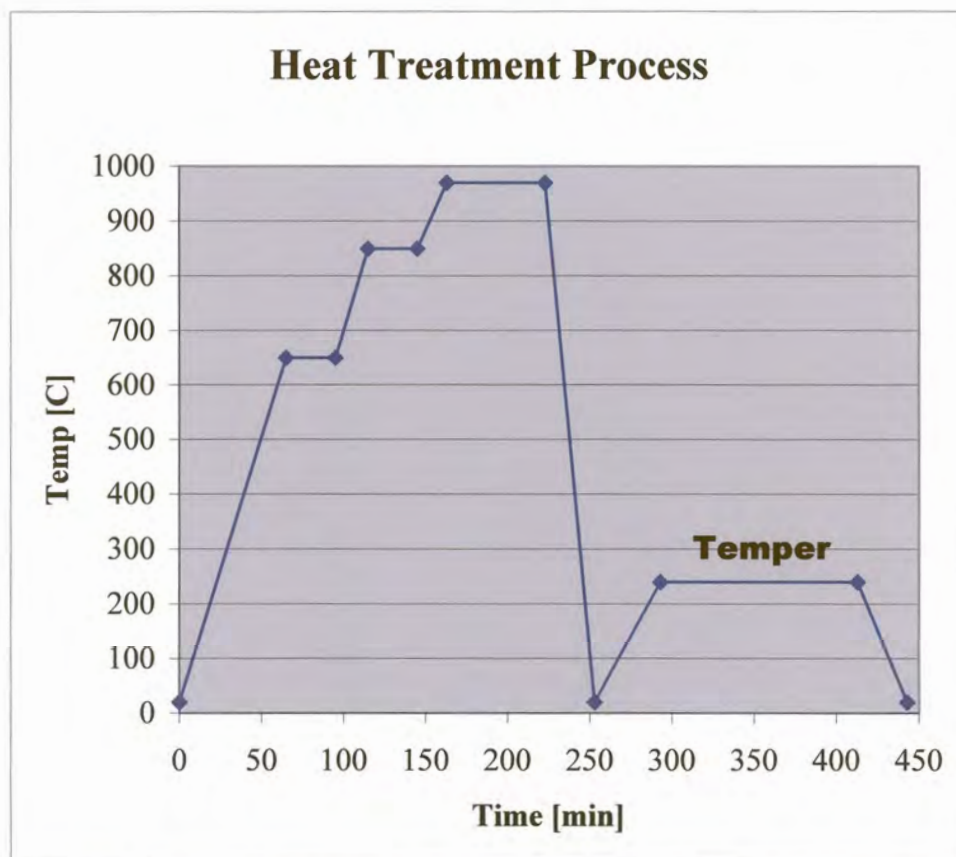


FIGURE 4.8(b) Temperature-time diagram of Heat Treatment process.

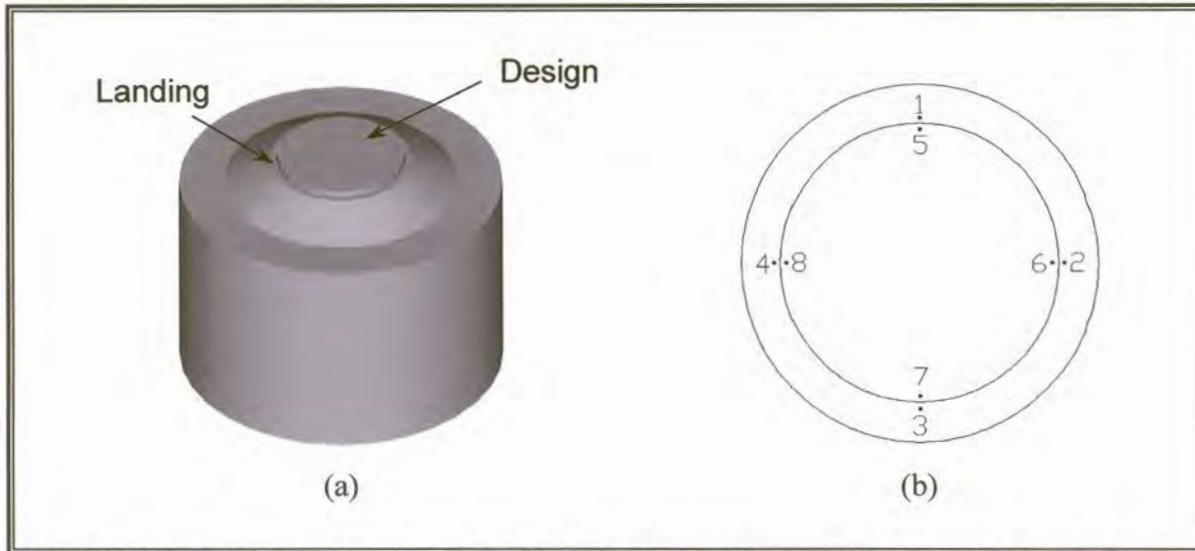
## 4.6 Test 2: Heat Treatment

### 4.6.1 PURPOSE

The purpose of the test was to quantify the shape change of the dies due to the heat treatment process. It was seen in Test 1 that the dies experience a shape change during heat treatment. Test 2 will concentrate on the effect of heat treatment alone, no plastic deformation will be induced on the dies. The shape change during heat treatment of a die, which has experienced plastic deformation, will be tested at a later stage. Since no plastic deformation will be induced on the dies, any shape change that occurs is entirely due to the phase transformation of the microstructure during heat treatment.

### 4.6.2 PROCEDURE

Two dies were made for the test, using Thyrodur 2363 billets with a diameter of 50 mm. The dies were turned on a lathe at a high speed to improve the surface finish. Liberal use was made of coolant to prevent the dies from work hardening. A landing was cut into the dies, 170 microns deep and 1mm wide (See Figure. 4.9). This was done to observe the relative stability of different planes under heat treatment. The dimensional stability of the landing relative to the design surface was also measured. Figure 4.9 (a) shows a computer model of the dies that were used for Test 2. Figure 4.9 (b) shows the measuring points on the dies. The dies were measured at four points on the circumference of the landing and four points on the design. The measurements were taken from the base of the design using the Linear Height Meter. After the two dies were measured they were sent for heat treatment to be hardened to a hardness of 60 HR<sub>c</sub>. A hardness test was done on the two dies and the values were documented.



**FIGURE 4.9 (a) Computer model of Test 2 dies. (b) Layout of measuring points.**

#### 4.6.3 RESULTS

The hardness of the dies was measured at three randomly chosen points on the circumference of the die and an average was calculated. The Leco 2100 Hardness Tester was used for the hardness tests. The hardness of the dies is 59.3 and 59.8 HR<sub>c</sub> respectively. The dies were once again measured and the sets of results were compared. The results are shown in the Table 4.4 and graphically in Figures 4.10 to 4.13. The results are accurate within a tolerance of  $\pm 4$  microns. The measurement tolerance is also shown on the Figures.

The landing depth, i.e. the difference between the design height and the landing height was calculated because the landing depth is the size that will affect the coining process. This is the distance the material must flow during the coining or hobbing processes to fill the landing recess. It is evident that the stability of different planes relative to each other is very important. The results of the landing depth are shown in Table 4.5 and graphically in Figures 4.14 and 4.15.



**Die Measurements**

\* All measurements are in millimeters

		Die No. (Soft)		Die No. (Hardened)	
		1	2	1	2
<b>Reference Points</b>	1	37.815	36.600	37.828	36.616
	2	37.815	36.600	37.827	36.623
	3	37.819	36.600	37.832	36.626
	4	37.817	36.601	37.830	36.622
	5	37.985	36.772	38.001	36.789
	6	37.986	36.771	37.998	36.795
	7	37.987	36.772	37.999	36.798
	8	37.982	36.771	38.000	36.794

TABLE 4.4 Die measurements in the soft and hardened state

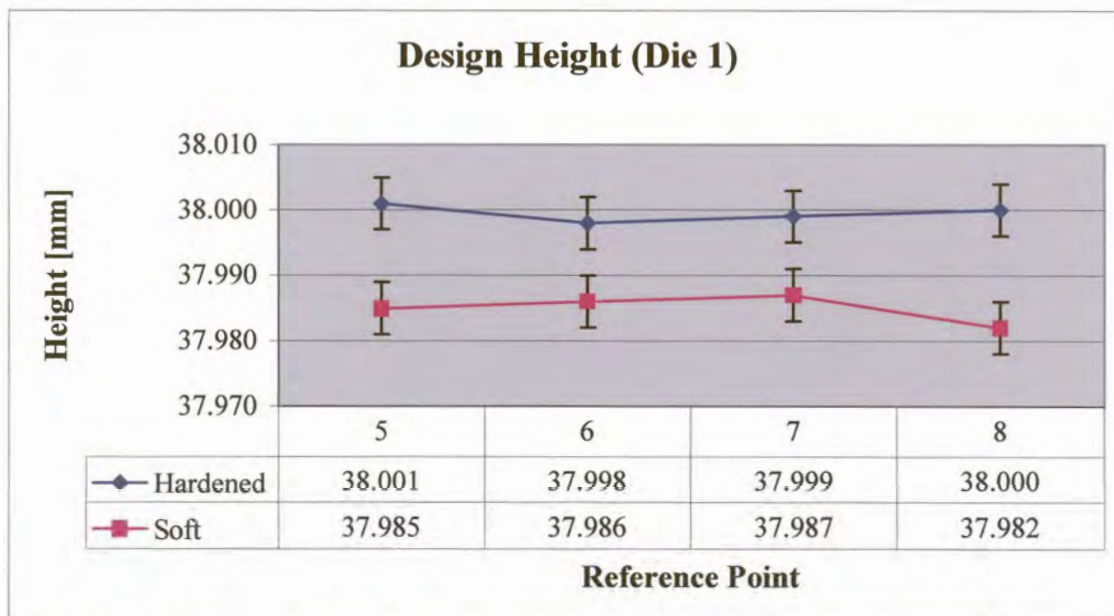
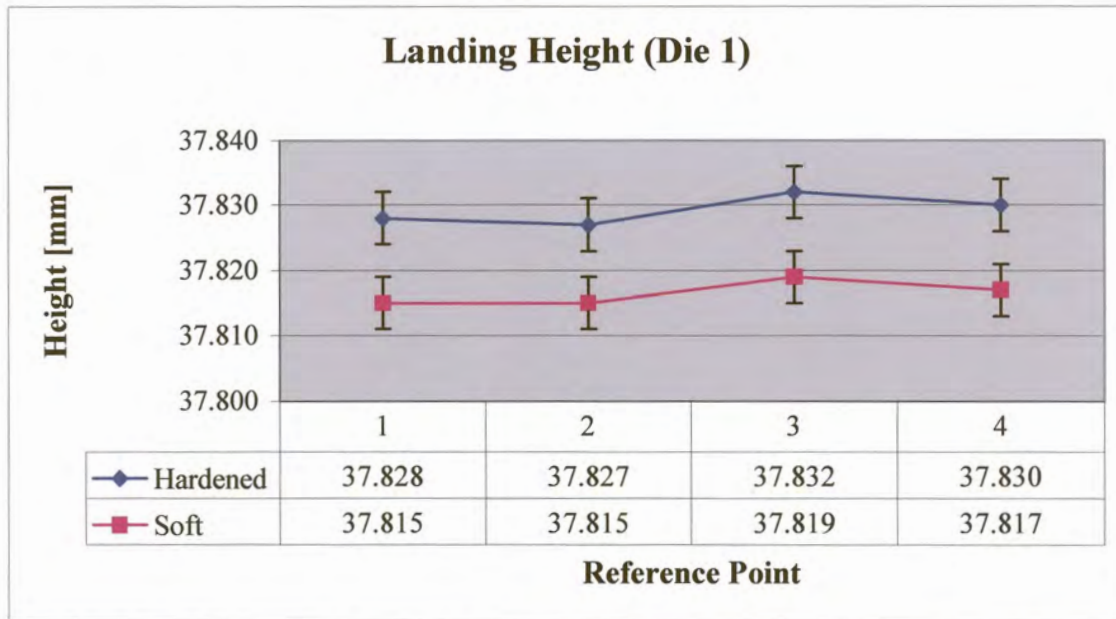
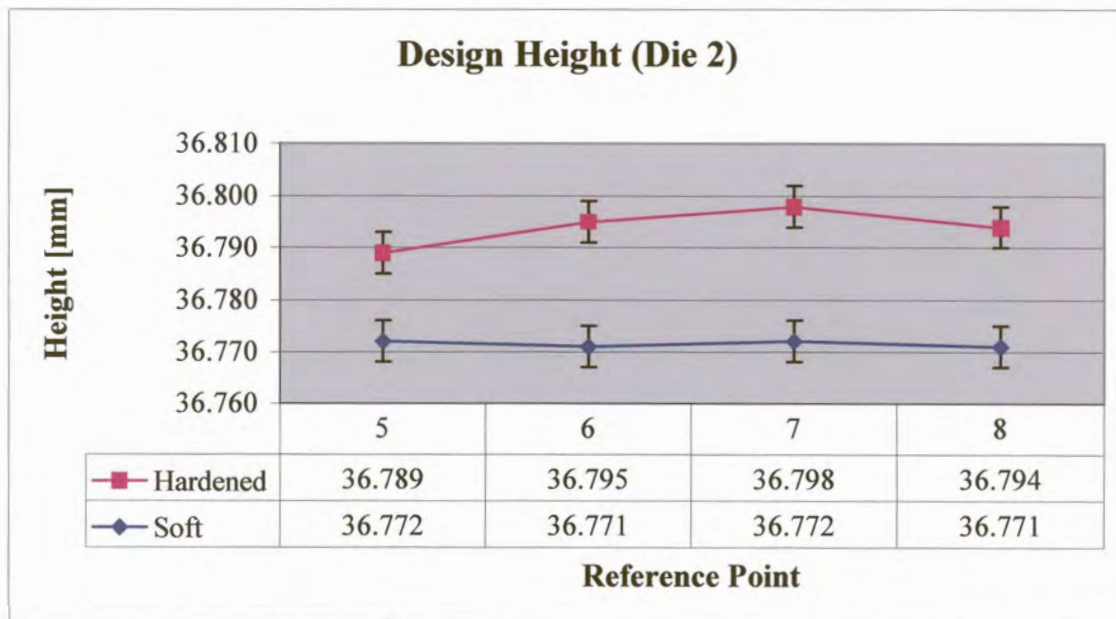


FIGURE 4.10 Absolute height of the design surface before and after heat treatment (Die 1).

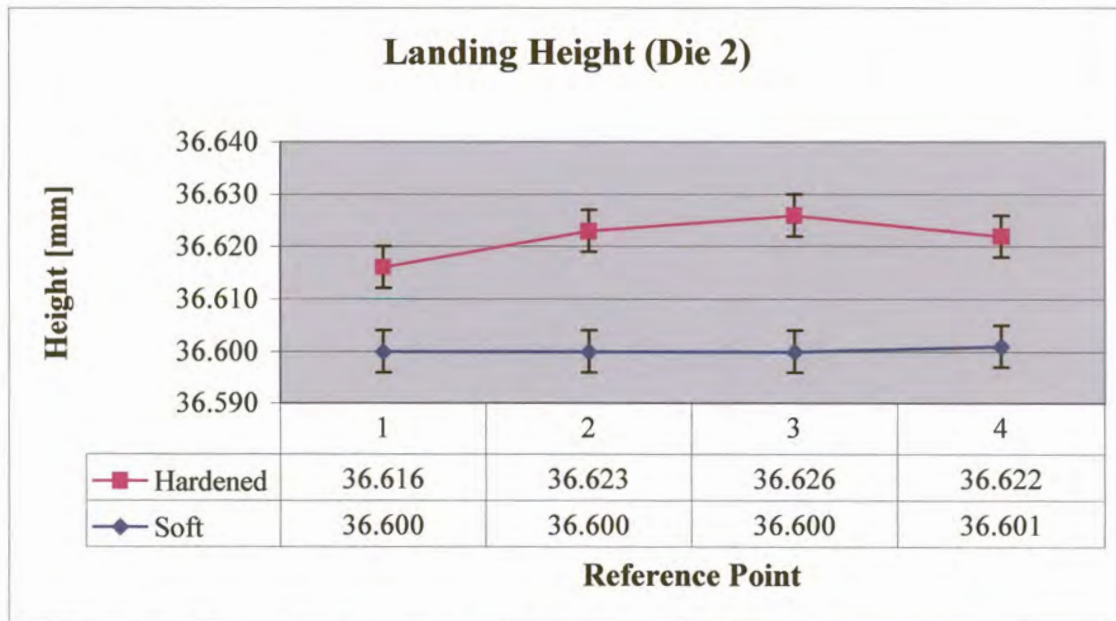




**FIGURE 4.11** Absolute height of the landing surface before and after heat treatment (Die 1).



**FIGURE 4.12** Absolute height of the design surface before and after heat treatment (Die 2).



**FIGURE 4.13** Absolute height of the landing surface before and after heat treatment (Die 2).

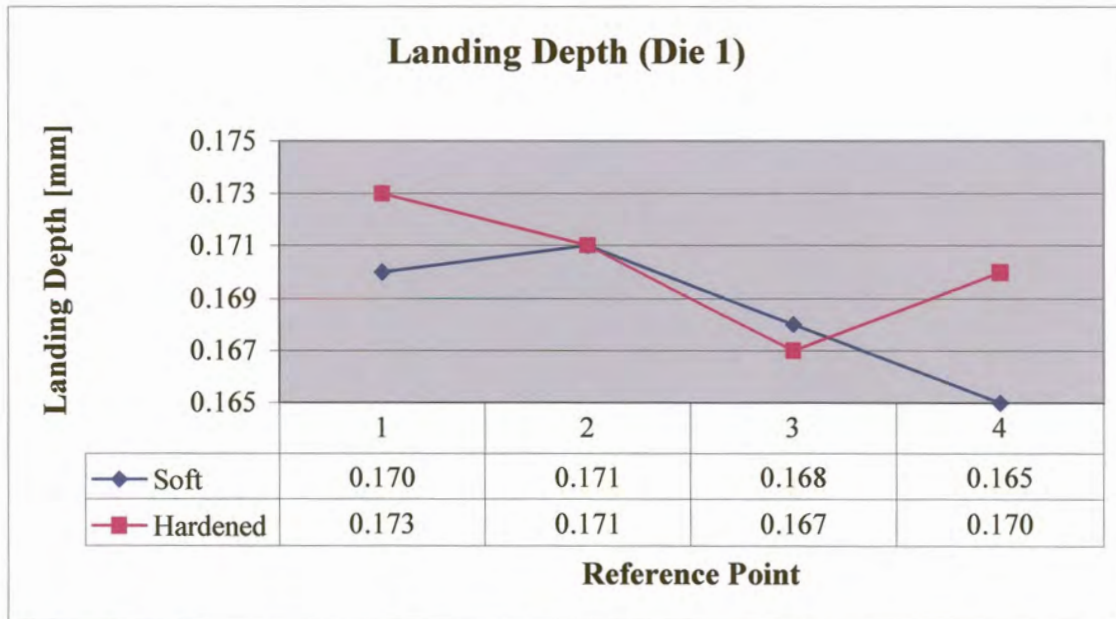
**Landing Depth**

		<u>Die 1</u>		<u>Die 2</u>	
		<i>Soft</i>	<i>Hardened</i>	<i>Soft</i>	<i>Hardened</i>
<i>Reference Points</i>	<i>1</i>	0.170	0.173	<i>1</i>	0.172    0.173
	<i>2</i>	0.171	0.171	<i>2</i>	0.171    0.172
	<i>3</i>	0.168	0.167	<i>3</i>	0.172    0.172
	<i>4</i>	0.165	0.170	<i>4</i>	0.170    0.172

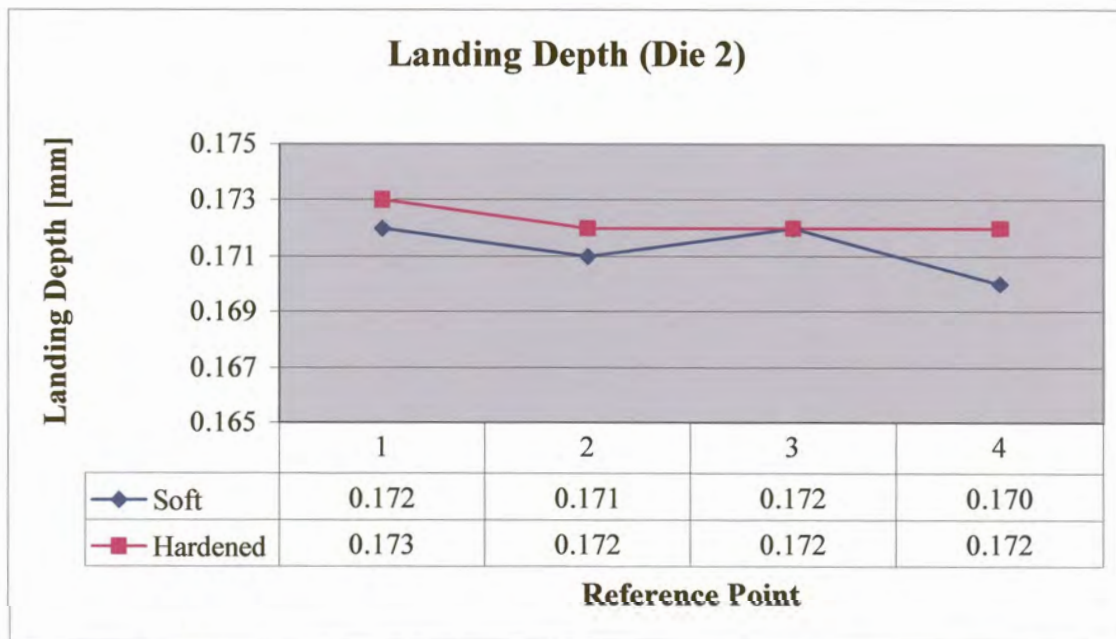
\* All measurements in mm

**TABLE 4.5** Landing depth at reference points 1 to 4

Figure 4.14 and 4.15 were plotted using the data in Table 4.5. A tolerance of  $\pm 4$  microns is also applicable to the results of the landing depth. The tolerance was not plotted on the graphs since all the data points lie well within the tolerance.



**FIGURE 4.14** Landing depth of die, before and after heat treatment (Die 1).



**FIGURE 4.15** Landing depth of die, before and after heat treatment (Die 2).

From Figure 4.10 to 4.13 it can be seen that the dies expand a certain amount during heat treatment. Die no.1 expanded with an average of about 14 microns while Die no.2 expanded with an average of about 22 microns. A certain amount of shape change is expected due to the transformation of the microstructure. It is important to note that the landing depth (Figure 4.14 and 4.15) did not change significantly during the heat treatment process.

#### **4.6.4 CONCLUSION**

It is desired that the landing depth remain constant. Although a small variance in depth of a few microns is expected due to the heat treatment process it should be noted that the small differences in depth are within the accuracy tolerance of the measuring procedure.

The shape change of the dies was relatively stable but more data is needed before a conclusion can be reached. It was decided that Test 3 would be similar to Test 2.



## **4.7 Test 3: Heat Treatment**

### **4.7.1 PURPOSE**

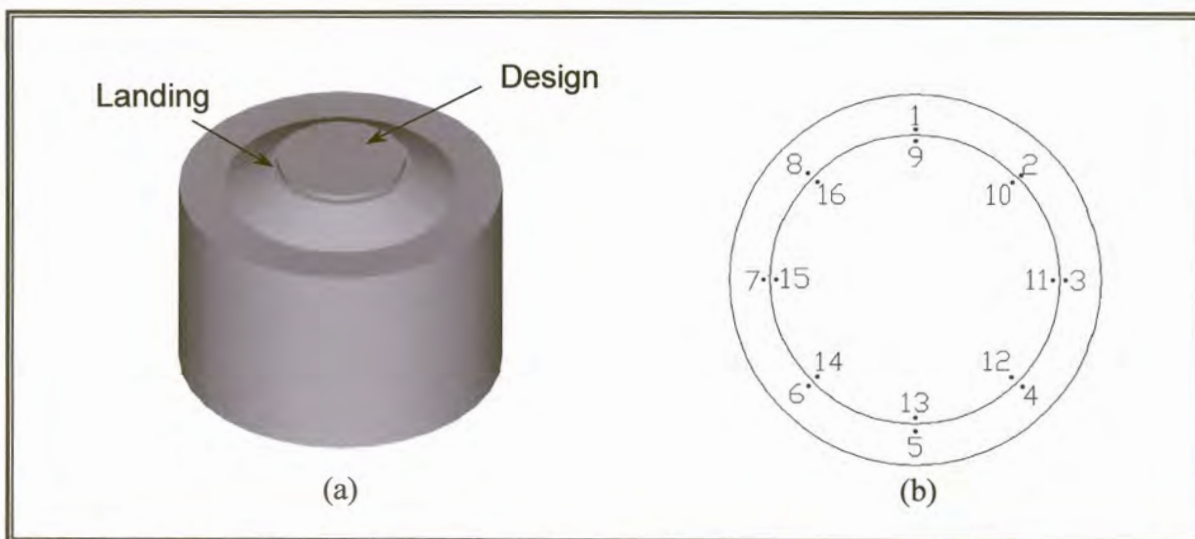
The objective of Test 3 was the same as for Test 2, i.e. to determine the effect of heat treatment on the dimensional stability of the dies, without inducing plastic deformation on the dies prior to heat treatment. The same procedure was followed as for Test 2, except for a few minor changes that were made to the test protocol. These changes will be discussed shortly.

It was seen from the results of Test 2 that the dies experience a certain amount of shape change during the heat treatment process. It would be instructive to obtain more test data about this deformation. Once more data has been collected, a conclusion can be reached about the shape change of the dies during the heat treatment process.

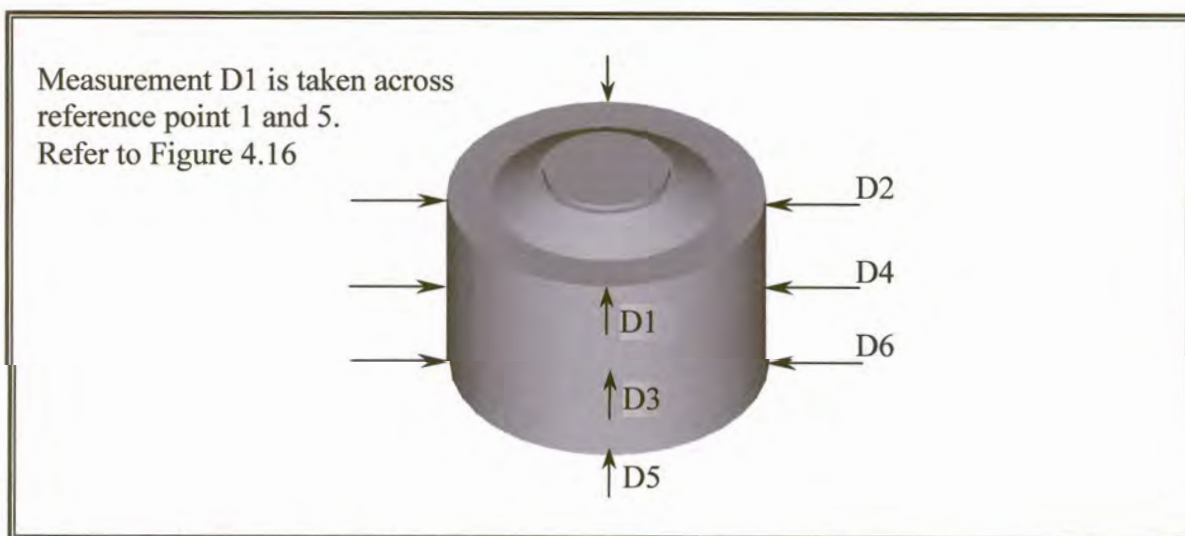
### **4.7.2 PROCEDURE**

Three dies were made for Test 3. The dies were turned on a lathe, with a landing but without a design. The landing is about 170 microns deep and 1 mm wide (See Figure 4.16(a)). Die 3.3 was also offset with about 25 microns to see if the skew plane would be maintained through the heat treatment process. The measuring points were increased from 8 to 16 so that more data can be obtained during the test. The layout of the measuring points is shown in Figure 4.16 (b). In addition to the 16 measuring points on the surface of the die, the diameter of the dies was also measured. The diameter was measured at the top, in the middle and at the bottom of the dies. Two measurements were taken perpendicular to each other at each of the three locations. Figure 4.17 shows the diametrical measurement

locations. A reference mark was made on the dies to ensure consistency and repeatability when the measurements are taken. Diametrical measurements were taken with a digital micrometer. The three dies were made and then measured. After the measurements were taken the dies were sent for heat treatment, to be heat-treated to a hardness of 60 HR<sub>c</sub>. A hardness test was done on the dies after which they were measured a second time.



**FIGURE 4.16 (a) Computer model of dies. (b) Layout of measuring points**



**FIGURE 4.17 Layout of diametrical measuring points**

### 4.7.3 RESULTS

The results of the hardness test are shown in Table 4.6. The hardness of the dies is higher than expected. The difference in hardness can be due to non-uniform cooling rates experienced by the dies or due to incorrect temper temperatures. During the production process the hardness should be checked to ensure that the hardness is close to the required value. These factors will be discussed further in Section 4.8. The results of the diametrical measurements are shown in Table 4.7 and the results of the surface measurements are shown in Table 4.8.

<i>Hardness Test.</i>			
<i>Die No.</i>	<b>3.1</b>	<b>3.2</b>	<b>3.3</b>
<i>Hardness [HR<sub>c</sub>]</i>	61.8	60.7	61.9

**TABLE 4.6 Hardness results of dies**

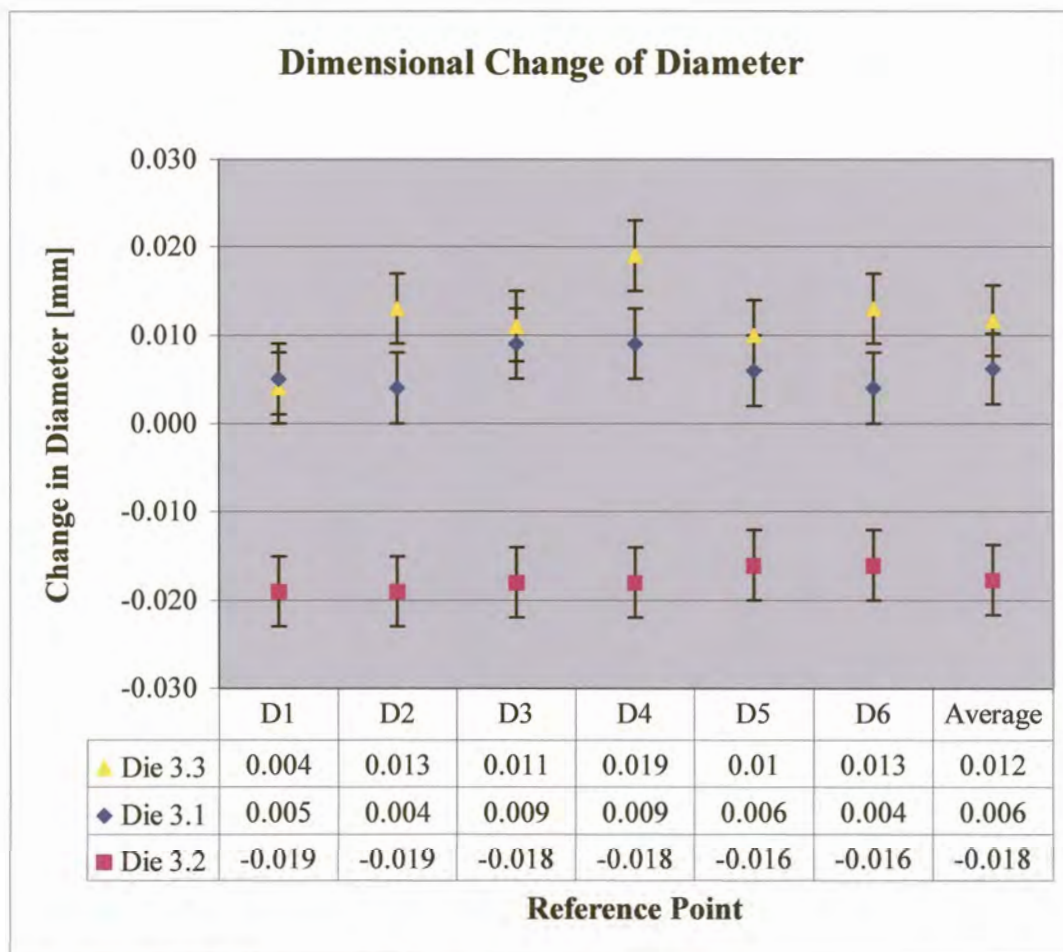
<b><u>Diametrical measurements</u></b>							
* All measurements are in millimeters							
	<i>Die No. (Soft)</i>				<i>Die No. (Hardened)</i>		
	<i>Die 3.1</i>	<i>Die 3.2</i>	<i>Die 3.3</i>		<i>Die 3.1</i>	<i>Die 3.2</i>	<i>Die 3.3</i>
<b>D1</b>	50.028	50.018	49.909	<b>D1</b>	50.033	49.999	49.913
<b>D2</b>	50.028	50.018	49.907	<b>D2</b>	50.032	49.999	49.920
<b>D3</b>	50.025	49.995	49.916	<b>D3</b>	50.034	49.977	49.927
<b>D4</b>	50.025	49.995	49.916	<b>D4</b>	50.034	49.977	49.935
<b>D5</b>	50.019	49.984	50.008	<b>D5</b>	50.025	49.968	50.018
<b>D6</b>	50.021	49.986	50.009	<b>D6</b>	50.025	49.970	50.022

**TABLE 4.7 Diameter measurements of the dies in the soft and hardened state.**



The exact diameter of the dies that were used for the test is of little importance since we are interested in the relative shape change of the die. Therefore only the differences in diameter will be plotted. Example for Die 3.1:  $D1_{\text{Hard}} - D1_{\text{Soft}} = 0.005$  mm.

The results are shown in Figure 4.18. The average change in diameter was also calculated for each die and plotted on the graph. The measurement accuracy tolerance of  $\pm 4$  microns is shown on the graph.

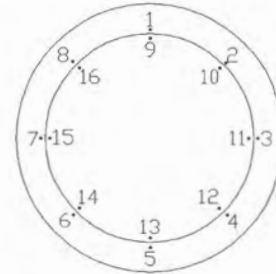


**FIGURE 4.18** Change in diameter after heat treatment.



### Die Surface Measurements

\* All measurements are in millimeters



#### *Die No. (Soft)*

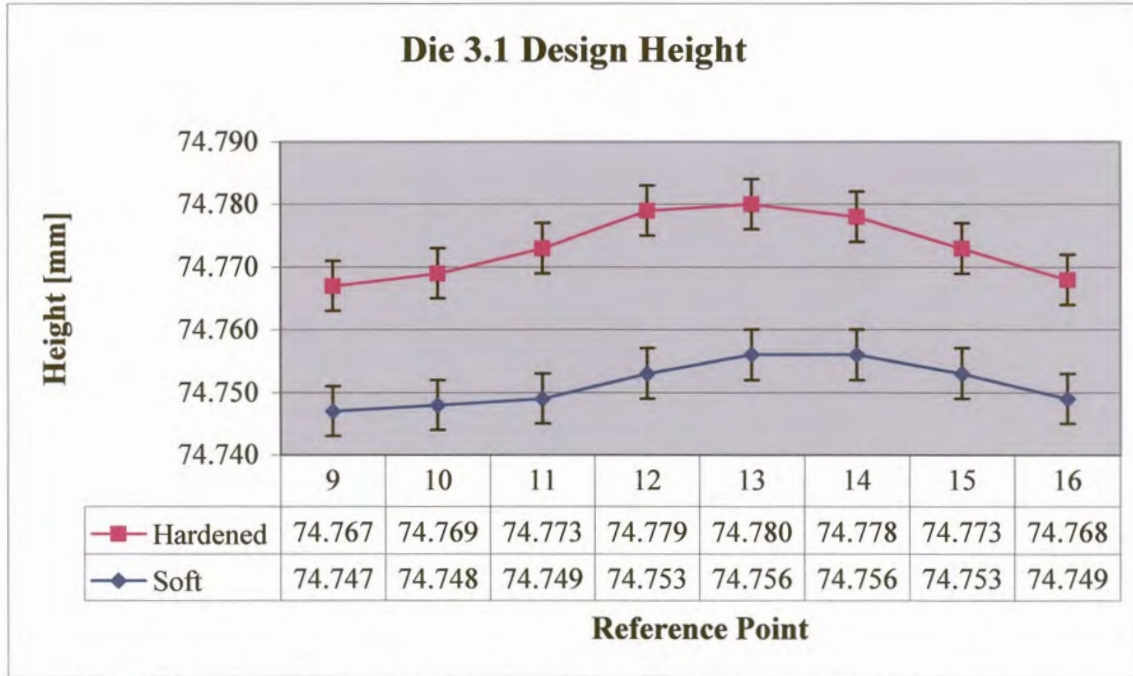
Reference points	<i>Die No. (Soft)</i>		
	3.1	3.2	3.3
1	74.569	74.452	73.663
2	74.569	74.452	73.658
3	74.572	74.452	73.647
4	74.572	74.453	73.637
5	74.574	74.453	73.633
6	74.573	74.453	73.639
7	74.573	74.451	73.649
8	74.570	74.451	73.660
9	74.747	74.631	73.814
10	74.748	74.631	73.810
11	74.749	74.632	73.802
12	74.753	74.633	73.792
13	74.756	74.633	73.790
14	74.756	74.633	73.796
15	74.753	74.634	73.804
16	74.749	74.633	73.812

#### *Die No. (Hardened)*

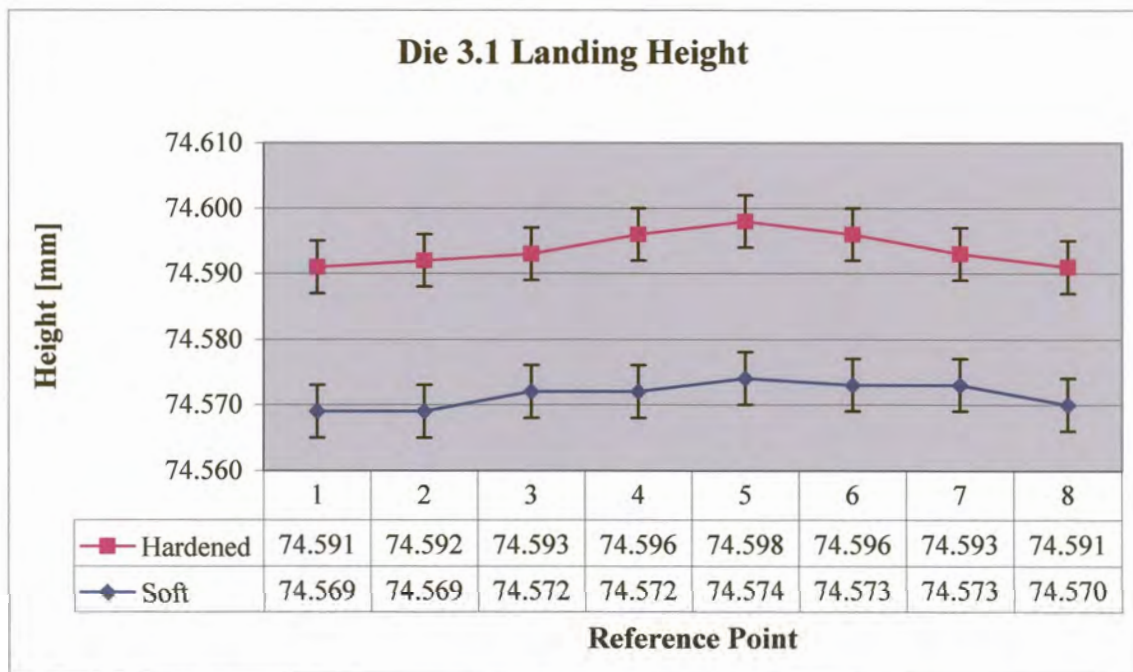
Reference points	<i>Die No. (Hardened)</i>		
	3.1	3.2	3.3
1	74.591	74.440	73.692
2	74.592	74.441	73.686
3	74.593	74.439	73.675
4	74.596	74.440	73.667
5	74.601	74.439	73.662
6	74.596	74.441	73.669
7	74.593	74.441	73.680
8	74.591	74.441	73.689
9	74.767	74.621	73.842
10	74.769	74.620	73.839
11	74.773	74.620	73.830
12	74.779	74.620	73.821
13	74.780	74.621	73.819
14	74.778	74.622	73.826
15	74.773	74.622	73.835
16	74.768	74.623	73.841

**TABLE 4.8** Die measurements of landing and design surface height.

The results of Table 4.8 were processed and plotted in Figures 4.19 to 4.24. The measurement accuracy tolerance is shown on all the graphs.

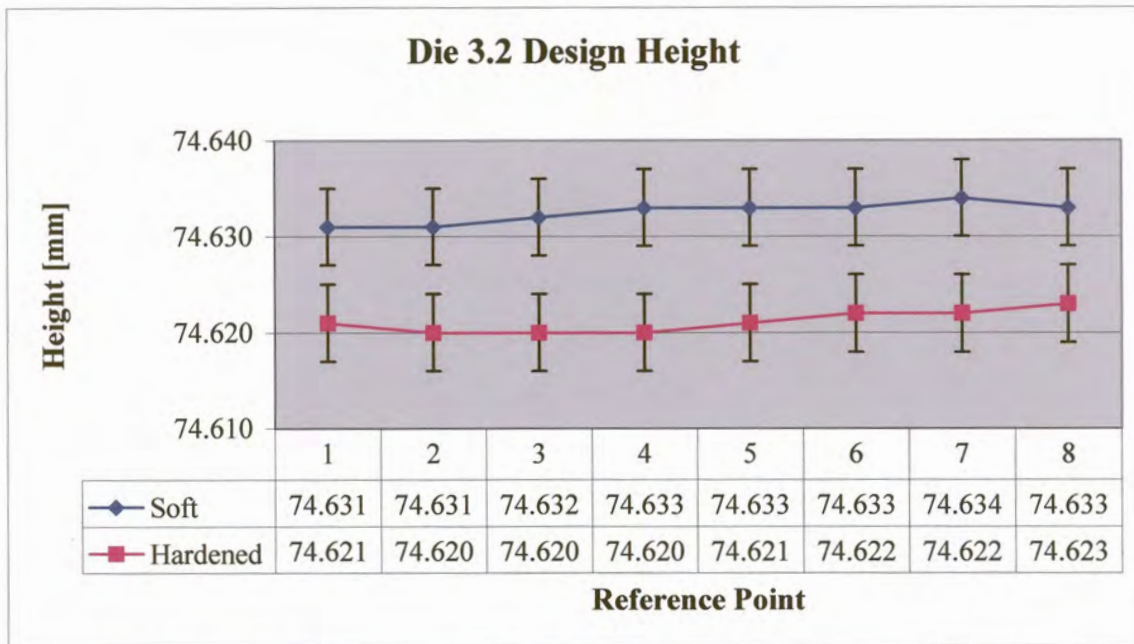


**FIGURE 4.19** Design surface height, before and after heat treatment.

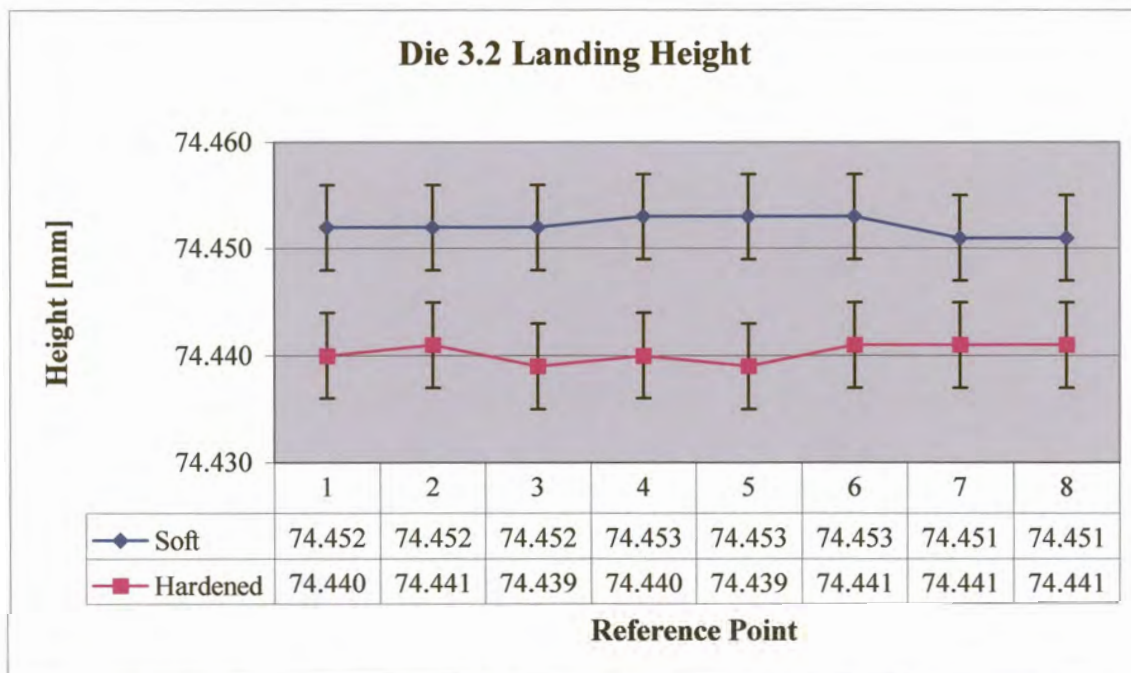


**FIGURE 4.20** Landing surface height, before and after heat treatment.

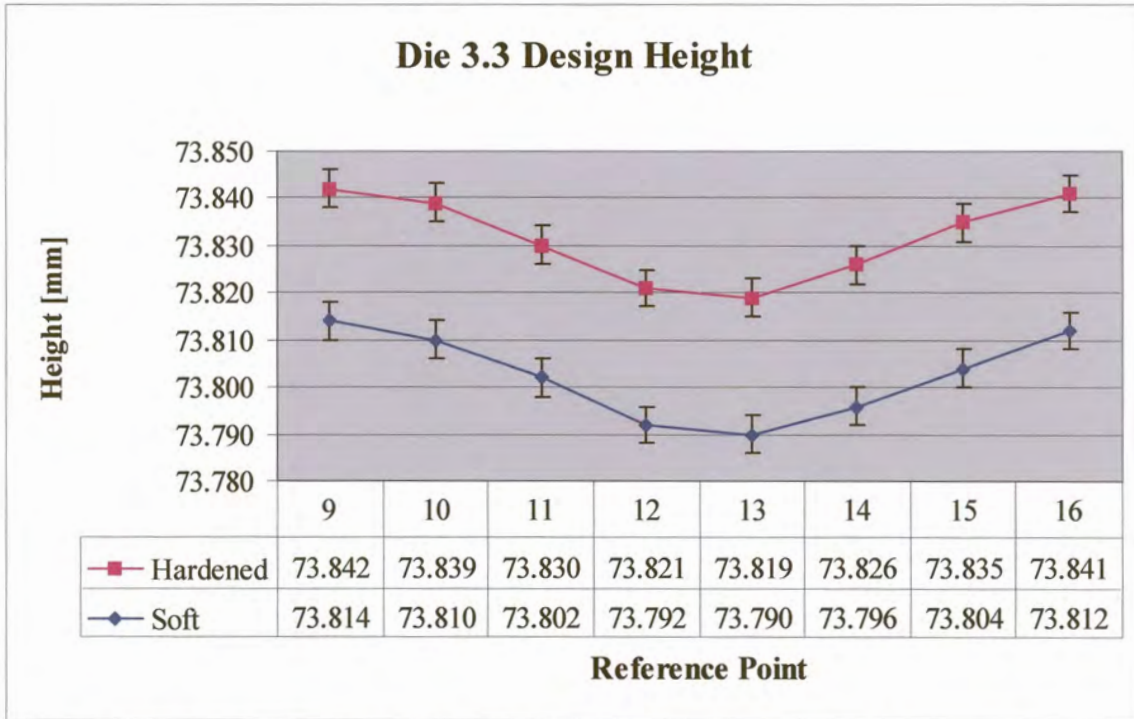




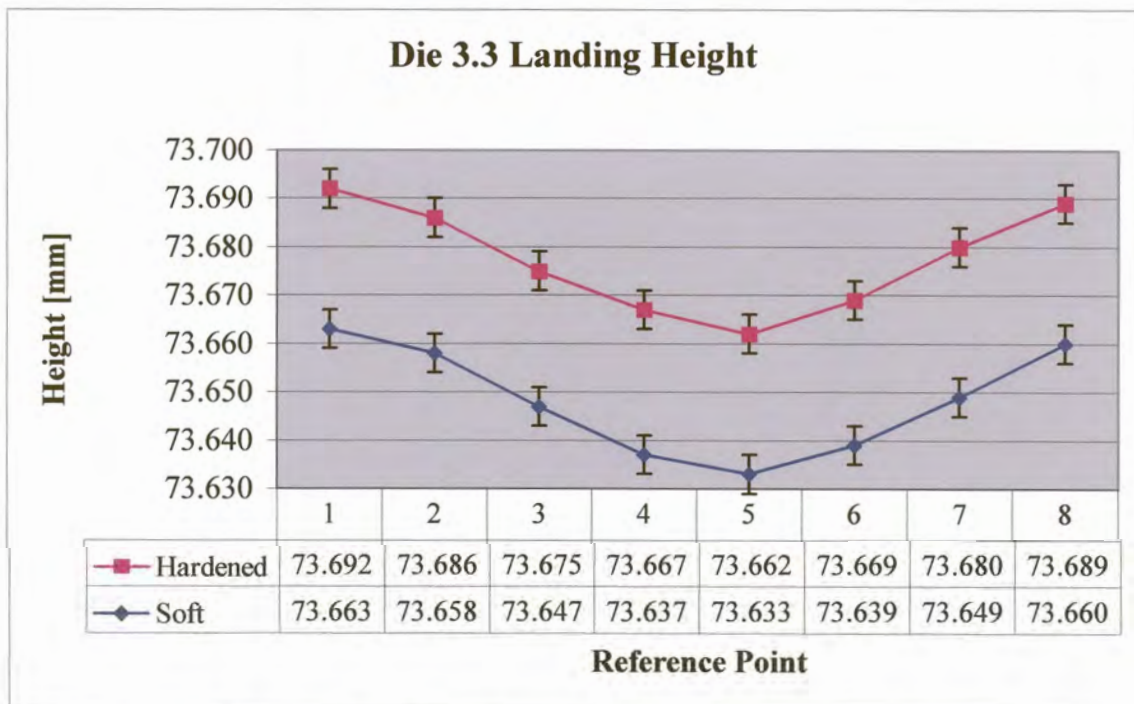
**FIGURE 4.21** Design surface height, before and after heat treatment.



**FIGURE 4.22** Landing surface height, before and after heat treatment.



**FIGURE 4.23** Design surface height, before and after heat treatment.



**FIGURE 4.24** Landing surface height, before and after heat treatment.



Summary of results:

Die 3.1	Length:	+ 22 microns
	Diameter:	+ 6 microns
Die 3.2	Length:	- 12 microns
	Diameter:	- 18 microns
Die 3.3	Length:	+ 29 microns
	Diameter:	+ 12 microns

There are two main causes of dimensional change during heat treatment. The one is thermal stresses, which occur as a result of the contraction of the material during cooling. The other main cause is transformation stresses, which occur as a result of the martensite formation.

Thermal stresses occur because the outer layer of the object cools more quickly and contract. The inner, softer parts try to assume a spherical shape during this process. This is the shape to which they offer the least resistance during deformation. Therefore any body tries to assume the spherical shape during rapid cooling. The more drastic the cooling rate, the greater are the changes due to thermal contraction.

During the heat treatment process the steel is subject to various heating and cooling stages, during these stages the steel undergoes a series of structural transformations. Transformation stresses are created because the various structural phases possess different densities and hence differing values of specific volume.

Martensite has a greater specific volume than austenite therefore during cooling, the steel will experience a volumetric expansion due to the transformation of austenite to martensite. After cooling, the steel will contain a certain amount of retained austenite. If the retained austenite content is sufficiently high, a volumetric reduction will take place. The hardening temperature can control the amount of retained austenite in the steel. The volume of the object decreases with an increase in hardening temperature, this being due to the increased amount of retained austenite. The volume of the object decreases further during tempering when the martensite decomposes to form ferrite and cementite.

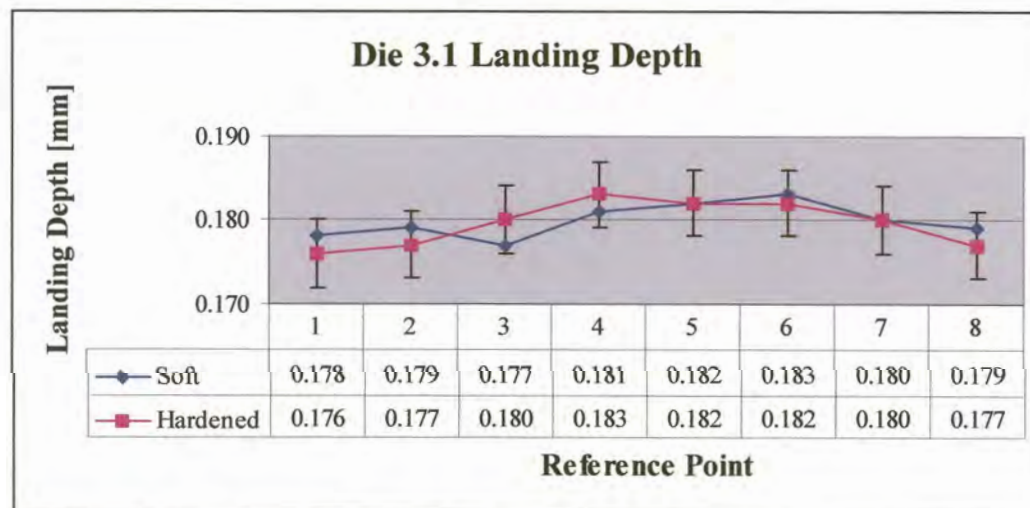
It is very difficult to calculate theoretical values for the shape change of tool steels during heat treatment. Theoretical calculations based on the specific volumes of the different structural phases are based on knowledge of the amount of each individual constituent present in the steel after hardening. These calculations also do not allow for dimensional changes due to thermal stresses or for the anisotropy of the steel. It is necessary to rely on empirical values obtain for different tool steels [1].

It was decided to calculate the percentage change in length and diameter of the dies to see if the deformation falls within typical dimensional change specifications given by manufacturers [2,3] for similar materials. The results are given in Table 4.9. The percentage change in length and diameter fall within typical specifications of manufacturers and therefore does not present a problem. It is however important to evaluate the relative stability of the surface planes as was discussed during Test 2.

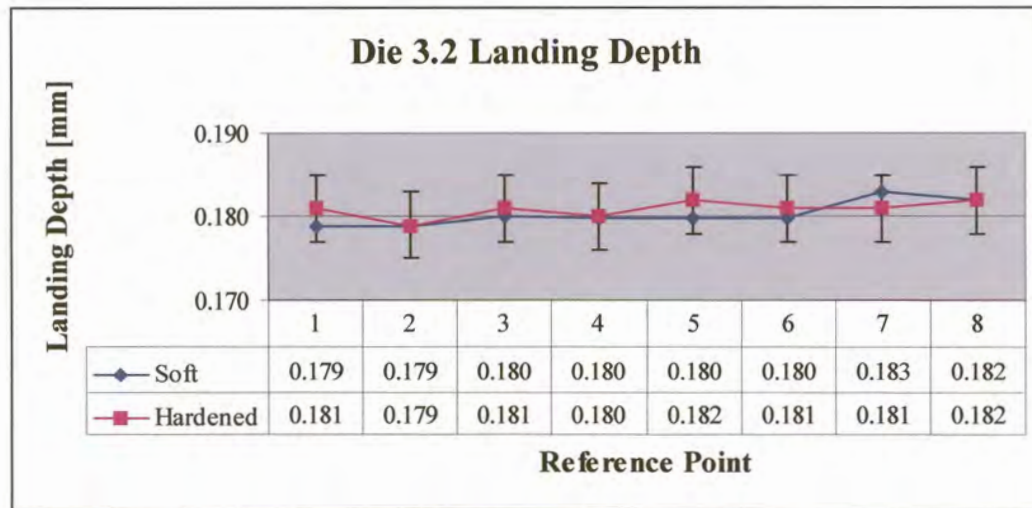
<b>% Dimensional Change</b>		
	<i>Length</i>	<i>Diameter</i>
<i>Die 3.1</i>	0.029	0.012
<i>Die 3.2</i>	-0.015	-0.035
<i>Die 3.3</i>	0.039	0.023

**TABLE 4.9** Percentage dimensional change during heat treatment.

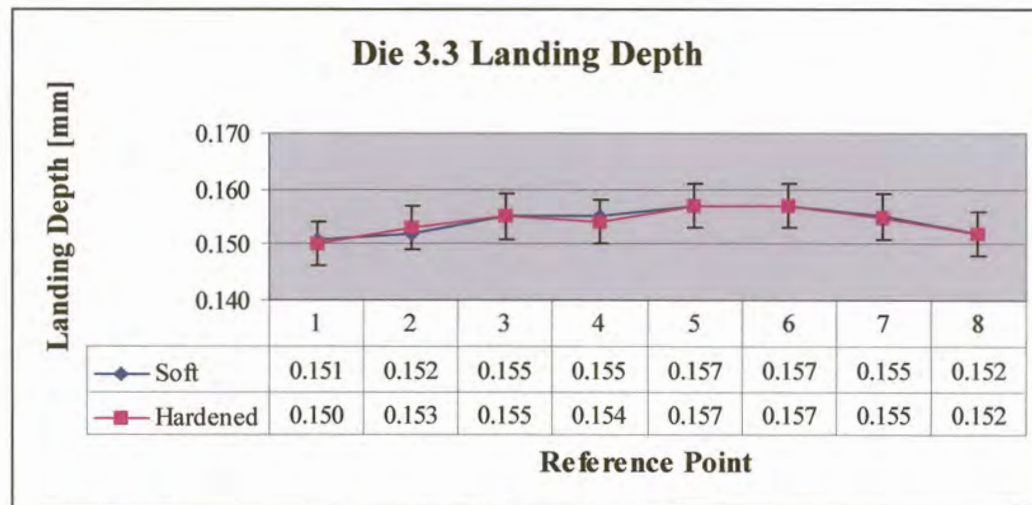
The landing depth was calculated before and after heat treatment and the results were plotted in Figures 4.25 to 4.27. It is evident that the landing depth remains close to constant and the differences seen in the graphs fall within the accuracy tolerance of the measuring procedure. This was also the case for Test 2 and one can therefore say that the relative dimensional stability of different planes is good. The last factor that will be considered is the relative stability of the design surface and the landing surface independently.



**FIGURE 4.25** Landing depth before and after heat treatment.



**FIGURE 4.26** Landing depth before and after heat treatment.



**FIGURE 4.27** Landing depth before and after heat treatment.

The question that must be asked is how does the shape of the design surface, for example, change during heat treatment. This can be easily evaluated by looking at the shape of the curves in Figure 4.19 to 4.24. The curves for the die in the soft and hardened state should have the same shape. This will suggest that although the design surface shifted upward or downward the actual design did not distort. From the figures it is evident that the surface stability for both the design surface and the landing surface is very good.



#### **4.7.4 CONCLUSION**

The shape change of the dies during heat treatment has now been properly quantified. A certain amount of change in diameter and length of the die can be expected during the heat treatment process (min: -0.04%, max: + 0.04%). The change in length does not present a problem since the dimensional changes are uniform across the entire die and this will not affect the coining or hobbing processes. It might be instructive to note the change in diameter when calculating die neck and collar sizes when very fine tolerances are required. The amount of shape change is however very small and can, for the most part, be regarded as insignificant.

The relative stability of the landing height, the landing surface and the design surface was also evaluated and the results showed very little dimensional distortion during the heat treatment process.

The importance of accurately controlling the heat treatment process cannot be overemphasized. Note that the hardness of Die 3.2 was merely 1 HR<sub>c</sub> softer than the other two dies, however Die 3.2 experienced a volumetric contraction and the other two dies experienced a volumetric expansion.

The results of Test 2 and 3 can be used as a guideline for the shape changes that occur as a direct result of the heat treatment process. This will make it easier to identify the different components of distortion in subsequent tests when plastic deformation will be induced on the dies and punches.

## 4.8 Test 4: Hobbing

### 4.8.1 PURPOSE

Test 4 will concentrate on the production of the master punches. The test will primarily focus on the factors that affect the accuracy and the quality of the master punches and ultimately the coining dies. The main test objectives were:

#### 1. Evaluate the shape change of the master punches.

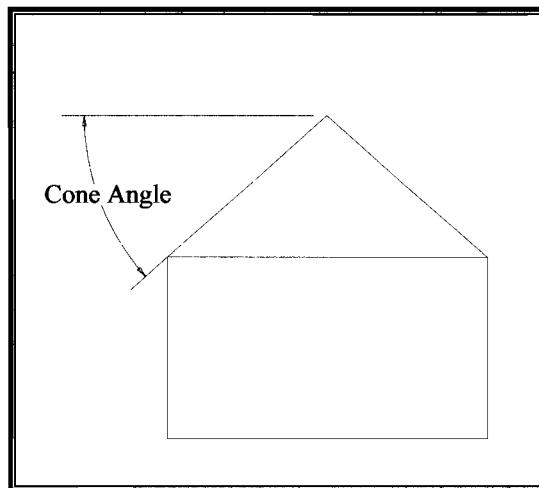
During the production process, the master punch undergoes several unwanted shape changes. The major factors contributing to these shape changes are:

- a) Elastic recovery of the material when the applied force is removed during the hobbing process.
- b) Transformation stresses during heat treatment.
- c) Thermal stresses during heat treatment.
- d) Residual stress relieving during heat treatment.

Test 4 will concentrate on the combined effect of the heat treatment and deformation processes involved. The shape change attributed to the heat treatment process alone has been properly quantified in the previous tests. The shape change of the master punch due to residual stress relieving combined with the transformation of the microstructure and the cooling stresses during the heat treatment process must now be evaluated and quantified.

**2. Determine optimum cone angle for the selected design.**

Die blanks, which are conical shaped at the one end are used to hob the master punch from the matrix and to hob the coining dies from the master punch. Currently a cone angle of thirty degrees is used when the die blanks are manufactured. The cone angle is measured from the horizontal plane downward as shown in Figure 4.28. Different cone angles will be tested and evaluated. The results will be used to specify the cone angle, which produces the best results for the selected design.



**FIGURE 4.28 Cone angle**

**3. Evaluate the effect of die blank hardness on hobbing force.**

Three die blanks will be annealed prior to hobbing. The effect of the reduced hardness on the hobbing force will be evaluated.

These were the three main objectives of the test. The procedure that was followed in conducting the test is shown below.

## 4.8.2 PROCEDURE

### 1. Generate computer model

A three-dimensional computer model must be generated of the design that will be used for the test. The two-dimensional design has already been established. It was now necessary to select the depth of the landing, the lettering and the design. A dome height had to be selected as well. The detail of the design was modeled relatively deep. By doing this, coining and hobbing defects are more likely to occur than with a shallow design. It will be easier to detect and evaluate the coining and hobbing defects if a deep design is used. A deep design will provide the analyst with more visual information about the process. The selected depths of the detail are as follows:

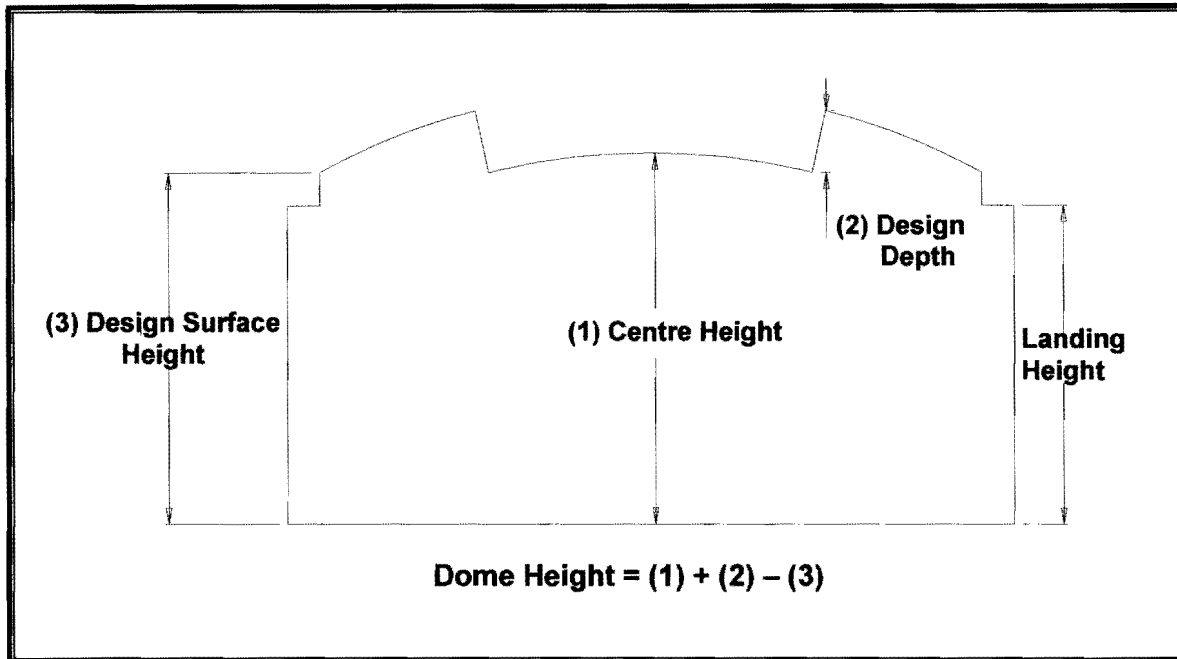
Design: 140 microns

Lettering: 115 microns

Landing: 160 microns

The next step was to select a dome size for the model. The dome spans the entire surface of the coining die. The dome height is specified as the vertical distance from the edge of the design surface to the centre of the projected design surface. The dome height was calculated in the following manner for the matrix. First the design height was added to reference point number 45 (See Figure 4.7), which is in the centre of the matrix. The average design surface height was then subtracted from this value to give the dome height (See Figure 4.29). A dome size of 40 microns was selected for the model.





**FIGURE 4.29 Procedure for calculating the dome height**

## 2. Manufacture Matrix

### a.) Prepare matrix blank

The matrix blank is a round billet of length 50 mm. Both sides of the billet are ground to ensure that the surfaces are parallel.

### b.) Cut matrix on CNC engraver.

The matrix is fixed to the Engraver bed and the detail is engraved on the matrix.

### c.) Machine relief into Matrix (See Figure 4.30(a)).

The matrix is removed from the engraver and a relief is machined into the matrix.

The hobbing force that is required to produce the master punch is reduced if the access material is removed from the outer edge of the matrix.

### d.) Remove cutter lines with grinding stone (By hand).

The engraver generates cutting lines on the cutting surface. These lines must be removed before the master punch is produced. The lines are removed with a small

grinding stone by one of the diesinkers. This is often done before and after hardening. The amount of grinding was limited for this test to maintain dimensional accuracy of the matrix. The cutter lines can also provide valuable information regarding the reproducibility of fine detail during the hobbing process.

**e.) Measure Matrix**

The matrix was measured according to the Die Measuring Chart (Figure 4.7). The procedure discussed in Section 4.4 was followed during the measuring procedure. See Appendix F for the results.

**f.) Heat-treat Matrix.**

The matrix was hardened according to the process discussed in Section 4.5.

**g.) Measure Matrix again.**

The matrix was measured again after heat treatment to evaluate the shape change of the matrix during heat treatment. The results are given in Appendix F.

**3. Manufacture die blanks with different cone angles.**

Various die blanks were prepared with different cone angles. The cone angles range from 20 to 40 degrees with 5-degree intervals. Two die blanks of each cone angle were prepared. 8 Die blanks were prepared for the 30° series. These blanks will be used to hob master punches. The die blanks were numbered according to the cone angle, followed by a serial number. For example, die blank 25.2 has a cone angle of 25° and is the second die blank in the 25° series. These die blanks will go through the different hobbing and heat treatment procedures. The dimensional changes of the punches will be monitored through every step. The punches are placed in a collar during the hobbing process to restrict the radial flow of material. This forces the material to flow

into the matrix design cavities. The transference of detail is much better than with unconstrained hobbing at the same tonnage but the amount of elastic recovery is much greater. To reduce the amount of elastic recovery during hobbing a relief zone was cut into the body of die blank 30.3. The diameter of the reduced section is 45 mm. See Figure 4.30 (b). The effect of the relief will be noted and if an improvement is observed additional tests will be done on die blank relief zones.

The results of constrained hobbing will be compared to the results of unconstrained hobbing by hobbing punch 30.5 in an open die process. Die blank 30.6 to 30.8 were annealed to reduce the hardness of the die blanks. These blanks were hobbled with a reduced hobbing force. The objective was to observe the quality of the detail transferred and the dimensional changes occurring for the different cone angles. The performance of each cone angle will be analyzed and evaluated.

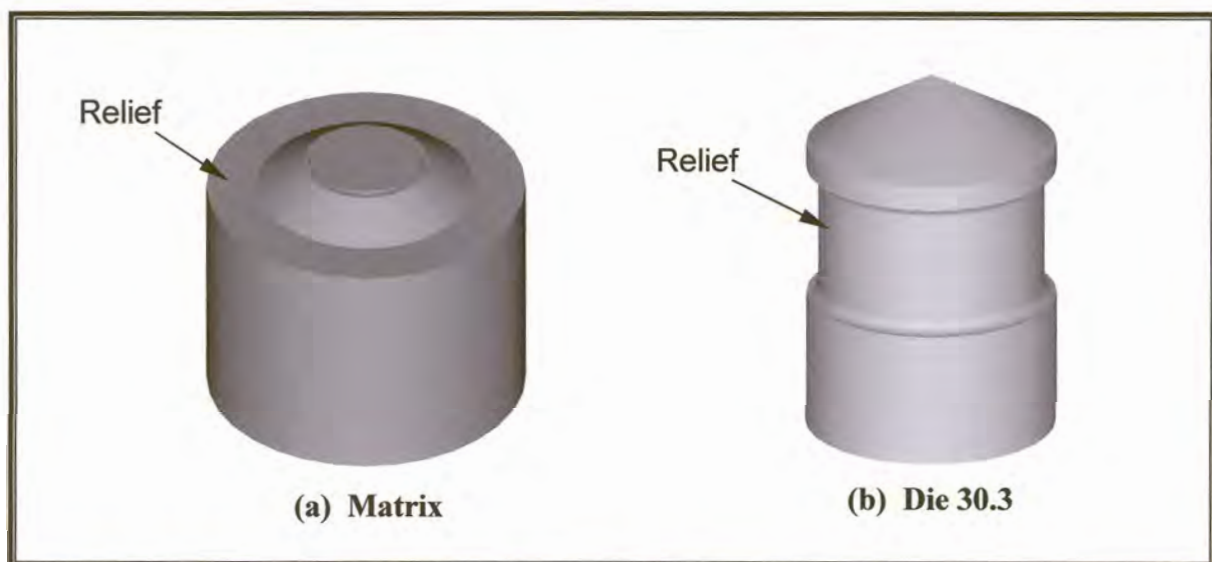


FIGURE 4.30 (a) Relief zone cut into matrix, (b) Relief zone machined into die blank

#### 4. Manufacture Master Punches.

##### a.) Hob master punches from matrix

All the master punches were hobbled on the Sack & Kiesselbach Oil Hydraulic Press. The hobbing process is done at a constant speed and the duration is approximately 4 minutes. A dwell time of 10 seconds was specified for the test.

All the normal master punches except one were hobbled with a maximum force of 180<sup>±1</sup> tons, punch 30.4 was hobbled with a maximum force of 200 tons. The softer die blanks were hobbled at 150, 160 and 170 tons respectively. The softer die blanks will not be measured nor heat-treated. The main purpose of these die blanks was to evaluate the detail transferred, compared to the normal die blanks.

##### b.) Machine master punches.

The master punches were turned according to specifications shown in Appendix C. A picture of the master punch is shown in Figure 4.31.

##### c.) Measure master punches

After the master punches have been machined they were measured according to the Die Measuring Chart. The results are shown in Appendix F.

##### d.) Heat-treat master punches.

The master punches were sent for heat treatment to be hardened. The hardness specification for the master punches is 59 HR<sub>c</sub>. After heat treatment the hardness of the punches were measured and the results obtained are shown in Table 4.10.

The differences in hardness are due to variances in the cooling rate during the heat treatment and tempering processes.



Punch No.	Hardness HR <sub>c</sub>
20.1	59.8
20.2	58.8
25.1	59.9
25.2	59.4
30.1	60.1
30.2	58.1
30.3	59.2
30.4	57.7
30.5	59.3
35.1	59.7
35.2	59.9
40.1	60.2
40.2	59.5
<b>Average</b>	<b>59.4</b>

**TABLE 4.10 Master Punch hardness****FIGURE 4.31 Master Punch****e.) Measure master punches**

The master punches were measured a second time to evaluate the response of the punches during the heat treatment process. The results are given in Appendix F.

**4.8.3 RESULTS**

All the measurement data and the resulting graphs are included in Appendix F. A summary of the results will now be discussed. For each of the punches an average was calculated for the following: Design Surface Height, Landing Height, Design Depth, Landing Depth, Lettering Depth and Dome Height. The results are given in Table 4.11.

The results of Table 4.11 are presented graphically in Figure 4.32 to Figure 4.36

**Master Punch Averages**

\* All measurements are in millimeters

**Surface Height**

<u>Soft</u>		<u>Hardened</u>	
<i>Die No.</i>	<i>Height</i>	<i>Die No.</i>	<i>Height</i>
20.1	65.550	20.1	65.517
20.2	65.466	20.2	65.447
25.1	64.369	25.1	64.359
25.2	64.540	25.2	64.536
30.1	62.861	30.1	62.835
30.2	62.883	30.2	62.833
30.3	59.566	30.3	59.542
30.4	61.663	30.4	61.634
30.5	60.235	30.5	60.228
35.1	61.370	35.1	61.363
35.2	61.218	35.2	61.208
40.1	59.335	40.1	59.326
40.2	59.495	40.2	59.473

**Landing Height**

<u>Soft</u>		<u>Hardened</u>	
<i>Die No.</i>	<i>Height</i>	<i>Die No.</i>	<i>Height</i>
20.1	65.723	20.1	65.692
20.2	65.642	20.2	65.624
25.1	64.544	25.1	64.535
25.2	64.716	25.2	64.711
30.1	63.033	30.1	63.011
30.2	63.057	30.2	63.008
30.3	59.749	30.3	59.727
30.4	61.839	30.4	61.811
30.5	60.415	30.5	60.409
35.1	61.544	35.1	61.538
35.2	61.392	35.2	61.383
40.1	59.511	40.1	59.502
40.2	59.672	40.2	59.649

**Design Depth**

<u>Soft</u>		<u>Hardened</u>	
<i>Die No.</i>	<i>Depth</i>	<i>Die No.</i>	<i>Depth</i>
20.1	0.135	20.1	0.135
20.2	0.136	20.2	0.135
25.1	0.136	25.1	0.136
25.2	0.135	25.2	0.136
30.1	0.135	30.1	0.138
30.2	0.135	30.2	0.137
30.3	0.137	30.3	0.137
30.4	0.135	30.4	0.136
30.5	0.137	30.5	0.136
35.1	0.136	35.1	0.137
35.2	0.135	35.2	0.136
40.1	0.136	40.1	0.137
40.2	0.136	40.2	0.137

**Landing Depth**

<u>Soft</u>		<u>Hardened</u>	
<i>Die No.</i>	<i>Depth</i>	<i>Die No.</i>	<i>Depth</i>
20.1	0.173	20.1	0.176
20.2	0.176	20.2	0.177
25.1	0.175	25.1	0.177
25.2	0.176	25.2	0.175
30.1	0.172	30.1	0.176
30.2	0.174	30.2	0.175
30.3	0.183	30.3	0.185
30.4	0.176	30.4	0.176
30.5	0.180	30.5	0.181
35.1	0.175	35.1	0.176
35.2	0.175	35.2	0.176
40.1	0.176	40.1	0.177
40.2	0.177	40.2	0.176

TABLE 4.11 Height averages for master punches



<u>Lettering Depth</u>				<u>Dome Height</u>			
<u>Soft</u>		<u>Hardened</u>		<u>Soft</u>		<u>Hardened</u>	
<i>Die No.</i>	<i>Depth</i>	<i>Die No.</i>	<i>Depth</i>	<i>Die No.</i>	<i>Height</i>	<i>Die No.</i>	<i>Height</i>
20.1	0.108	20.1	0.108	20.1	0.046	20.1	0.036
20.2	0.109	20.2	0.108	20.2	0.046	20.2	0.033
25.1	0.108	25.1	0.110	25.1	0.048	25.1	0.035
25.2	0.108	25.2	0.108	25.2	0.046	25.2	0.036
30.1	0.109	30.1	0.111	30.1	0.044	30.1	0.039
30.2	0.108	30.2	0.110	30.2	0.044	30.2	0.038
30.3	0.108	30.3	0.107	30.3	-0.041	30.3	-0.056
30.4	0.109	30.4	0.111	30.4	0.042	30.4	0.042
30.5	0.108	30.5	0.108	30.5	-0.002	30.5	-0.010
35.1	0.110	35.1	0.111	35.1	0.041	35.1	0.046
35.2	0.110	35.2	0.109	35.2	0.042	35.2	0.042
40.1	0.110	40.1	0.111	40.1	0.036	40.1	0.041
40.2	0.111	40.2	0.111	40.2	0.034	40.2	0.039

TABLE 4.11 cont. Height averages for master punches



FIGURE 4.32 Difference in height of the landing and design surface after heat treatment.

All the punches underwent a reduction in length during the heat treatment process. The reasons for this reduction have been discussed in Section 4.7. The scatter that is observed in Figure 4.32 is due to the differences in hardness after the heat treatment process.

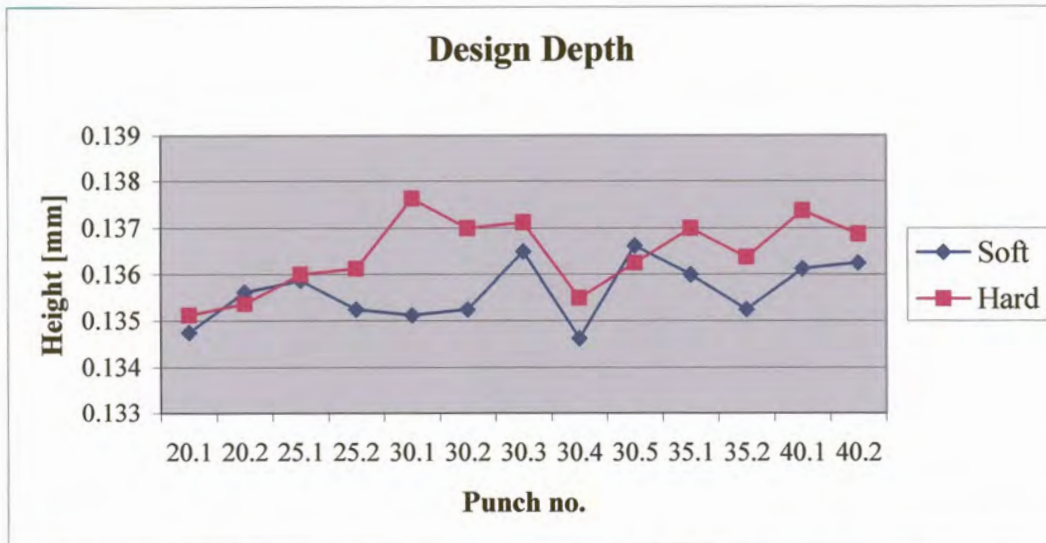


FIGURE 4.33 Average design depth before and after heat treatment.

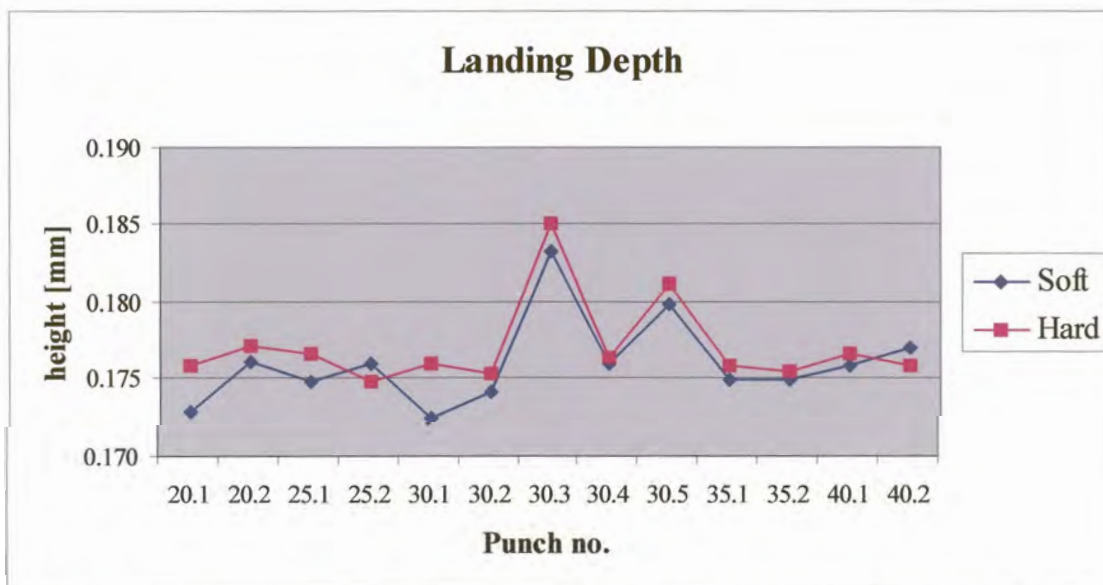
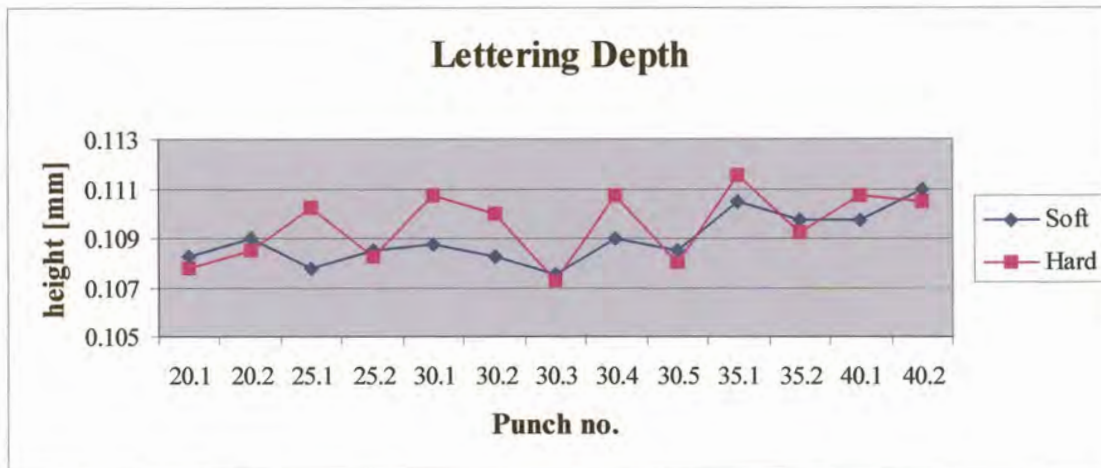


FIGURE 4.34 Average landing depth before and after heat treatment.

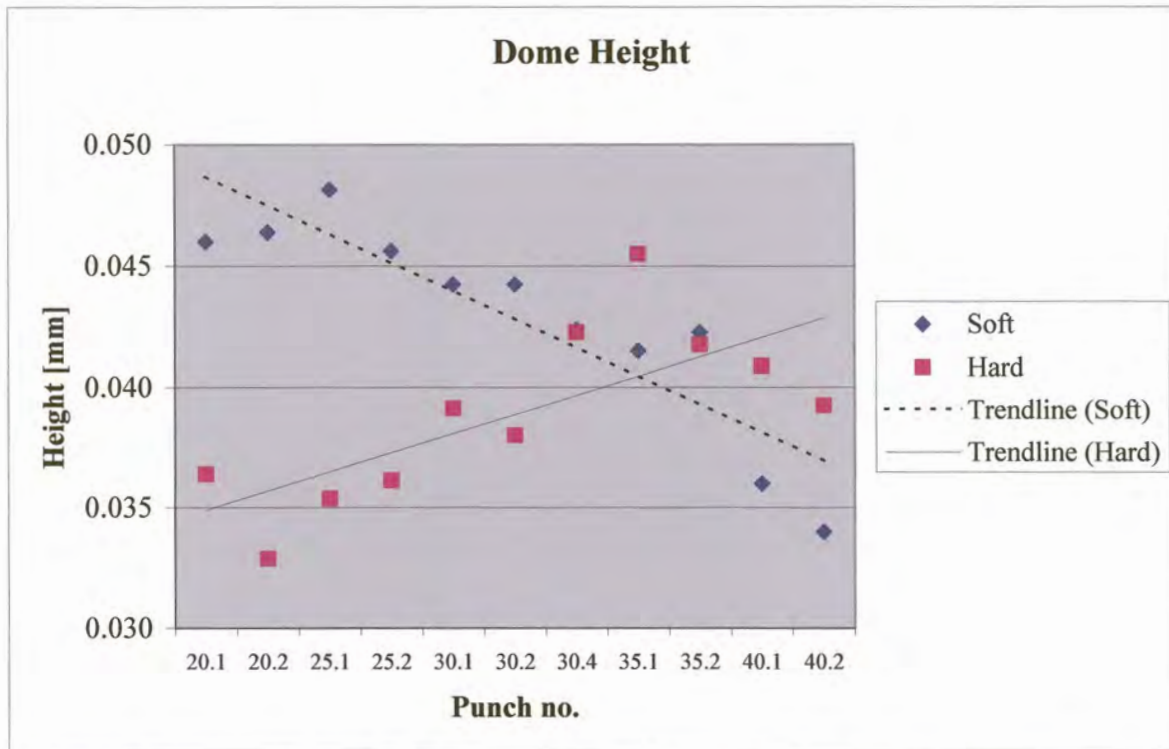




**Figure 4.35** Average lettering depth before and after heat treatment.

Figures 4.33 to 4.35 displays the depth of the detail before and after heat treatment. The design, landing and lettering depth remained close to constant through the heat treatment process. Any differences are within the accuracy tolerance of the measuring procedure ( $\pm 4$  microns).

The response of the dome height during the production process will now be evaluated. The dome height of the matrix was 33 microns after hardening. Very little change occurred in the dome height of the matrix during heat treatment. This is mainly due to the fact that no plastic deformation was induced on the matrix. However significant changes occurred in the dome size of the master punches during the hobbing and heat treatment processes. For instructive purposes the dome height of the punches was plotted before and after heat treatment. Punch 30.3, which had a relief zone in the body and punch 30.5, which was hobbled in an open die configuration, will not be included in the graph at this stage. The resulting plot is shown in Figure 4.36.



**FIGURE 4.36** Dome height of punches before and after heat treatment.

If the die blanks that were used in the hobbing process were made from lead, one would expect that the dome height of the master punches would be about  $-33$  microns after hobbing. However since a material is used that has a high yield strength a certain amount of elastic recovery will occur after the applied force is removed.

The amount of elastic recovery will be more in the centre of the punch since the material particles in the centre are constrained by adjoining particles and by friction due to contact with the matrix. The particles at the outer edge of the design is free to deform plastically due to the relief zone in the matrix thus there are less particles that are deformed elastically. The result is that the master punches have a positive dome of about  $40$  microns after hobbing.

The trendline that was fitted through the data for the soft punches clearly indicate that the amount of elastic recovery decrease with increasing cone angle (Figure 4.36). The punches with a large cone angle are subjected to more plastic deformation to fill the design. Particles that would have been under elastic strain are deformed past the yield point into the plastic zone. The result is less elastic recovery during hobbing.

During heat treatment the dome experience a further shape change. The punch undergoes a shape change due to transformation stresses and thermal stresses that are created during the heat treatment process (Ref. Section 4.7). Thermal stresses that cause the punch to contract are more pronounced in the center due to the temperature gradient present in the punch. These stresses cause the dome of the punch to shrink. This can clearly be seen in Figure 4.36 for the punches with a small cone angle. Note that the trendline that was fitted through the data of the hardened punches has a positive gradient.

The shrinking of the dome is counteracted by residual stress relieving. Residual stresses are set up in the punch during the hobbing process. Residual stresses are caused by an increase in the dislocation density of the material during plastic deformation. The dislocation density is reduced during heat treatment due to the phase transformation of the material to austenite, resulting in an increase in dome size. As was mentioned previously, the punches with a large cone angle endure more plastic deformation during hobbing therefore residual stress relieving increases with an increase in cone angle. At some point the shape change due to residual stress relieving exceeds the shape change due to thermal and transformation stresses. The net effect is that the dome rises during heat treatment. This point is evident from the results of the punches with a cone angle of 35° and higher.

It is also instructive to examine the dome height results of punch 30.4. The maximum hobbing force for punch 30.4 was 20 tons higher than the rest. The amount of elastic recovery was less for this punch than for the other punches with the same cone angle. The higher hobbing force induced more plastic deformation on the punch. Particles that were on the edge of plasticity at 180 tons were now deformed plastically, resulting in less elastic recovery. For the same reason the dislocation density increased and more residual stress relieving occurred during heat treatment. Caution should be taken when hobbing with a high hobbing force. An increased hobbing force could result in the premature failure of the punches.

To reduce the amount of elastic recovery a relief was cut into the body of punch 30.3. The relief zone allows more material to deform plastically. The result was a drastic reduction in the amount of elastic recovery after hobbing. However there was still a shape change during heat treatment and the dome shrunk with 11 microns. Therefore a relief zone does not guarantee a constant dome height during the manufacturing process.

The quality of the master punch is ultimately dictated by the amount of detail that was transferred from the matrix during the hobbing process. The approval of the master punches is subject to a visual inspection under 10 times magnification. Pictures were taken of the master punches after hobbing to evaluate the amount of detail transferred during the hobbing process from the matrix. These pictures are shown in Figure 4.38. The critical areas are highlighted in Figure 4.37. These areas will be evaluated for all the punches. All edges should be sharp and well defined.



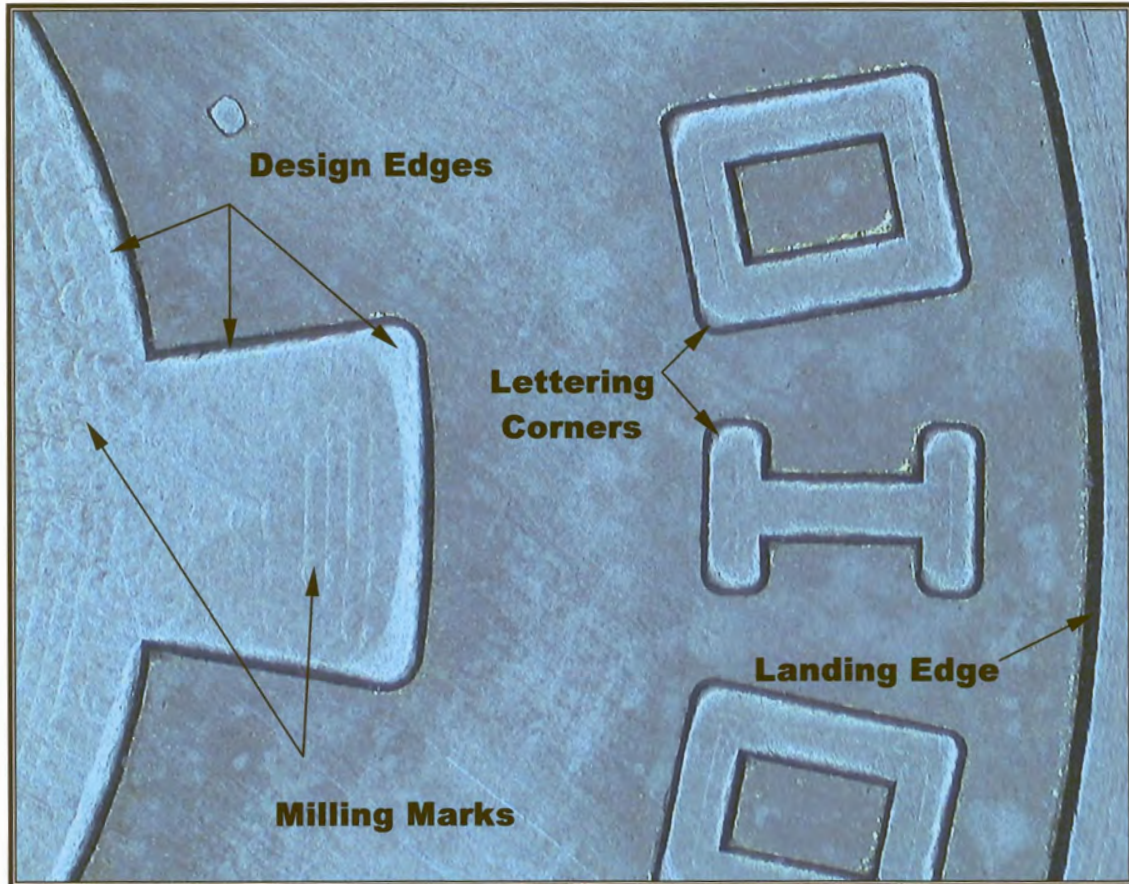


FIGURE 4.37 Critical detail transference areas indicated by arrows.

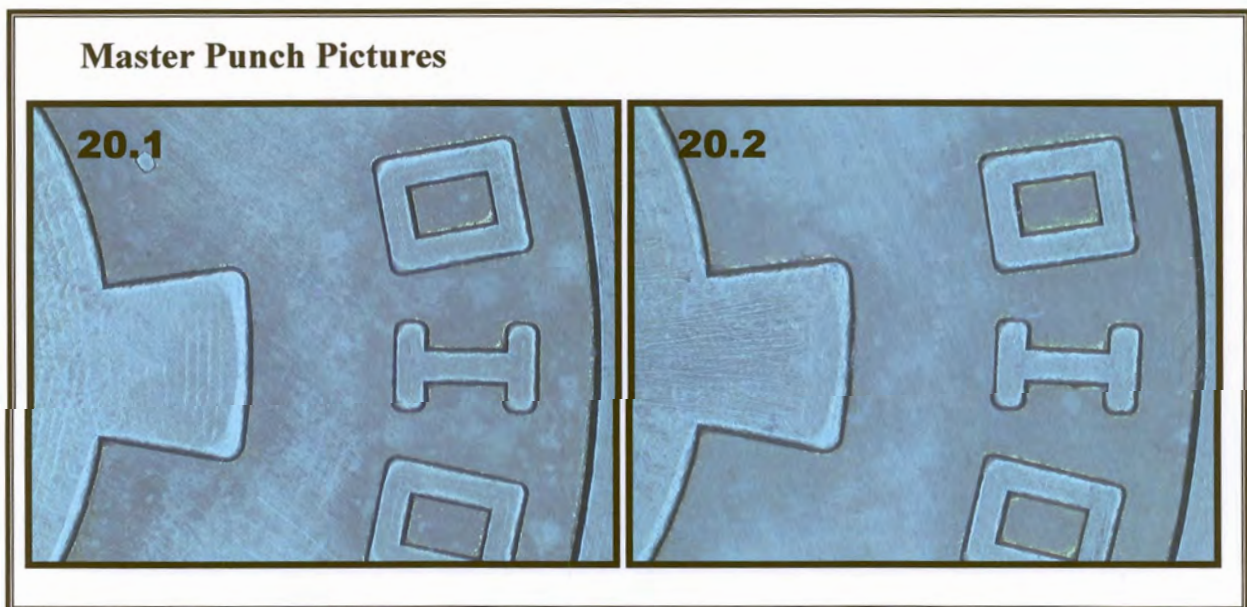


FIGURE 4.38 Pictures of Master Punches



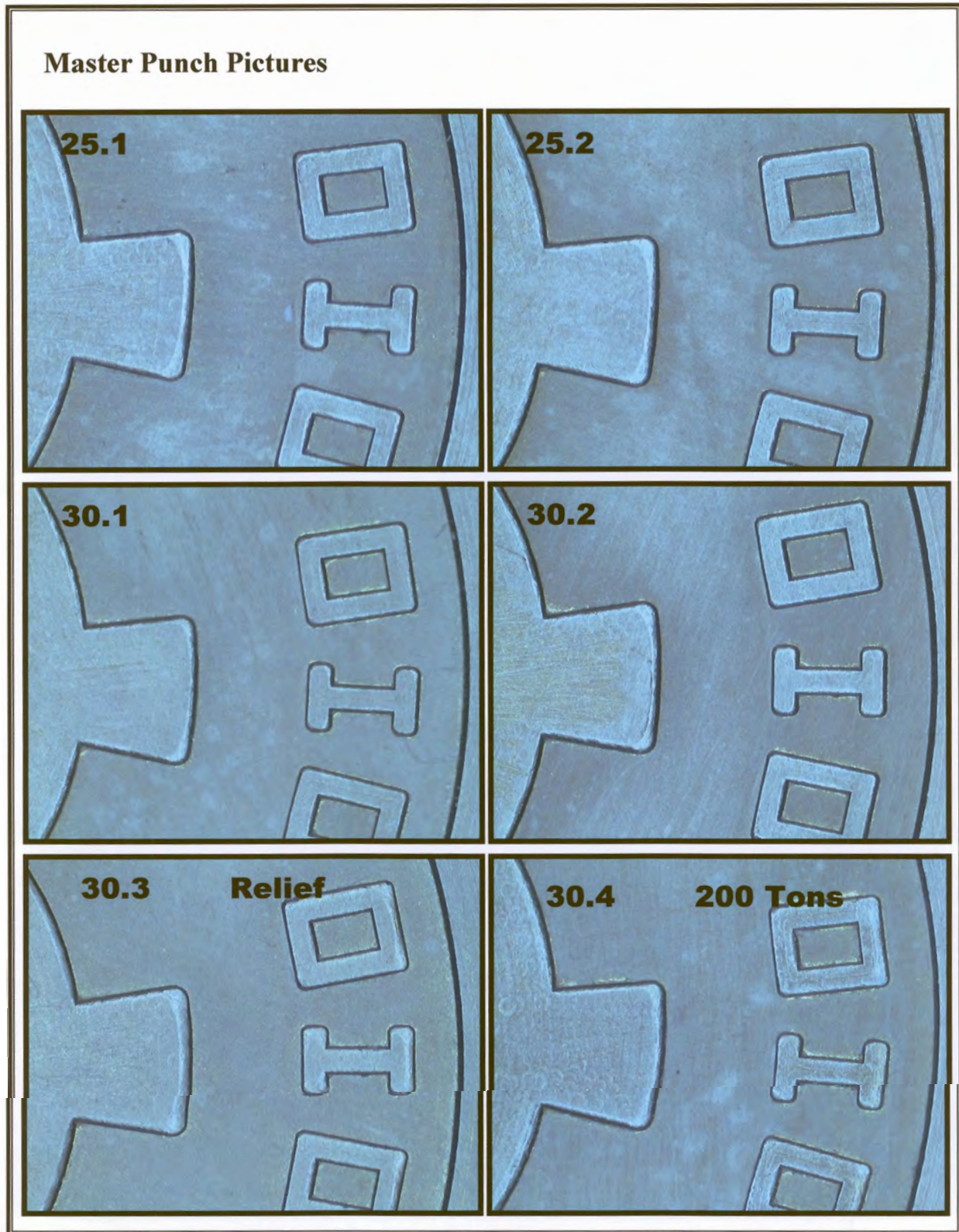


FIGURE 4.38 cont. Pictures of Master Punches



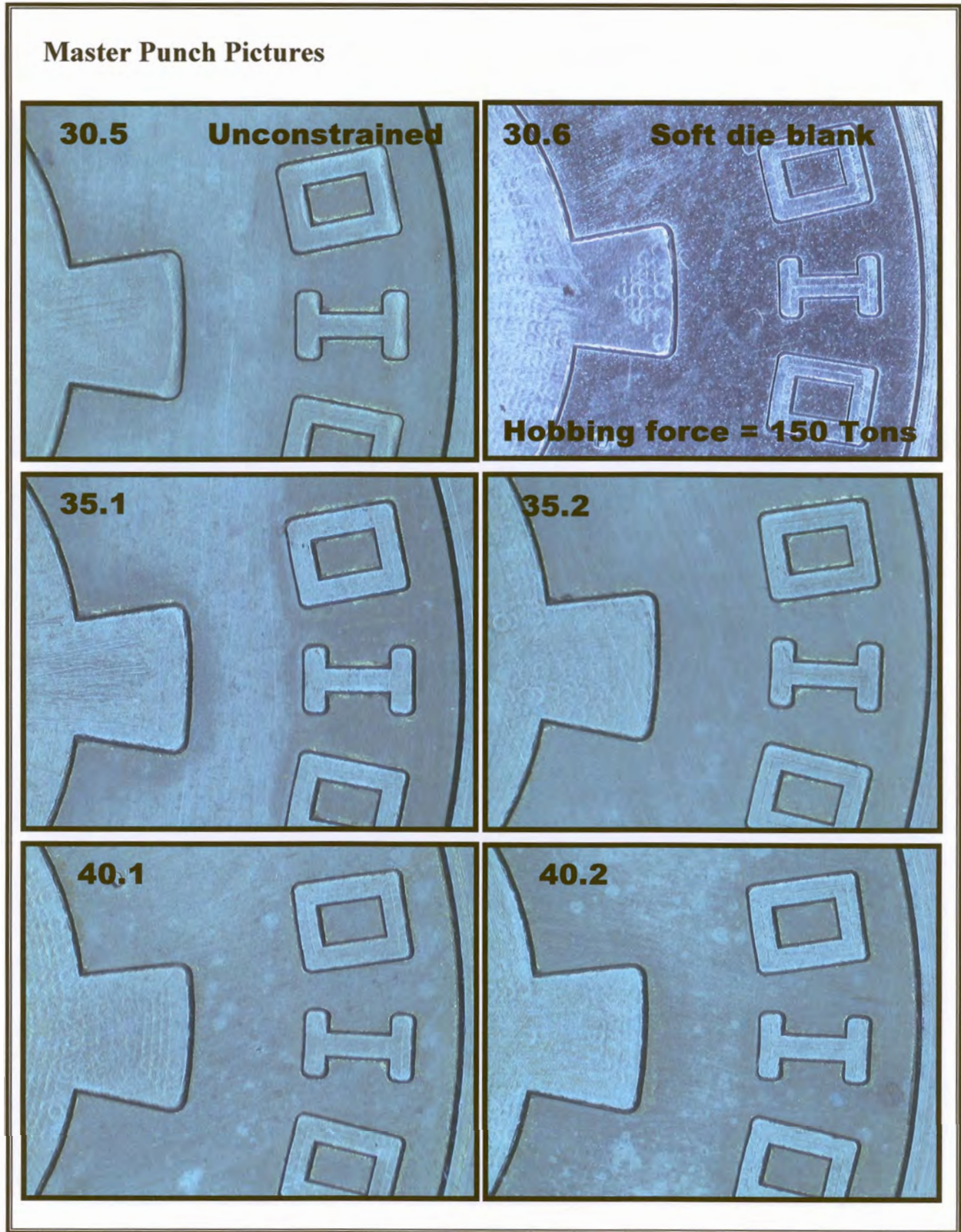


FIGURE 4.38 cont. Pictures of Master Punches

Upon inspection it was observed that all eight symmetrical sections of the design were identical. Therefore only one of the sections will be viewed. The sharpness of the detail increased with an increase in cone angle. When the matrix was manufactured the milling marks that was produced by the engraver cutter was not totally removed. The presence of these milling marks on some of the punches is a sign of high detail transference.

From Figure 4.38 it is evident that for this design the die blanks with a cone angle of 35° to 40° produced the best results regarding detail. The results obtained with cone angles of 20° to 25° produced results that are not acceptable. The results of punch 30.3 and 30.5 were also not acceptable. It is therefore evident that hobbing in a collar that restricts radial flow produces better results. Although the relief zone in punch 30.3 caused less elastic relaxation, the transference of detail was below standard and therefore no more test will be done on die blank relief zones.

Die blank 30.6 was annealed prior to hobbing. The hardness of the die blank after annealing was 92.8 HR<sub>b</sub> compared to the average hardness of 94.7 HR<sub>b</sub> of the normal die blanks. When compared to the master punch that was hobbled at 200 tons, with the same cone angle, it can be seen from Figure 4.38 that the soft die blank displays significant improvements in detail transfer at a hobbing load of 150 tons. This is a dramatic 25% reduction in hobbing force. The milling marks on the design and in the centre of the lettering are clearly visible on the softer punch.



There are two significant advantages for annealing the die blanks prior to hobbing. The first is that a smaller distribution in hardness can be ensured between the die blanks. This will improve consistency during hobbing. The other reason is that the required hobbing force can be reduced dramatically. The reduction in hobbing force will limit the amount of plastic deformation induced on the matrix and will allow for improved detail transference during hobbing.

#### **4.8.4 CONCLUSION**

During the hobbing and heat treatment processes the material undergoes various shape changes. It is not possible to avoid these shape changes altogether. The small percentage change in length and diameter that occurs during heat treatment is of little importance and does not present a problem during the production and development processes.

The amount of elastic recovery does present a problem as far as calculating the dome size is concerned. It was shown that the amount of elastic recovery could be controlled by increasing the hobbing force, by varying the cone angle or by introducing a relief zone in the body of the master punch. However it was also shown that a relief zone does not solve the problem.

The shape change of the dome during heat treatment is relatively small for cone angles of 30° and higher but it can be accounted for and with proper development it can be predicted.

The fact that there is a significant amount of shape change during the hobbing and heat treatment processes does not present a problem in itself. The problem lies therein that the shape change is often not consistent, and this presents a problem in accurately producing a coining die with a specified dome height. The key factor is consistency. If one can maintain consistency the developer can allow for these shape changes that occur. The solution to the problem is therefore to improve consistency in every aspect of the development process.

There is no specific hobbing force, die blank cone angle, dome height or any other characteristic that will produce the best results for all the projects. It is therefore imperative that significant amounts of data be obtained for all development projects. Successful development efforts rely on empirical data obtained from previous successful projects. This greatly improves consistency in all aspects. A few of the major aspects will be highlighted.

- The hobbing force.
- Die blank diameter.
- Die blank hardness.
- Matrix hardness.
- Dome height.
- Cone angle.
- Heat treatment temperatures.
- Machining practice

A change in any one of these factors can greatly affect consistency. With an extensive database in hand repeatability is easier to achieve and inconsistencies can be explained and properly managed.

Because hardness greatly affects the hobbing process, the raw material that is used during development should have a uniform hardness. The hardness should be measured on all raw materials to ensure uniformity. If the bandwidth of the hardness results is large an extra annealing process should be considered. The amount of elastic recovery will depend on the initial hardness of the punch and it is therefore extremely important that all the punches have the same hardness prior to hobbing. The results also showed that an extra annealing process will reduce the required hobbing force and will improve the quality of the master punch detail.

The heat treatment process should be modified to ensure homogeneous heating and cooling of all punches and dies. Dies should not be packed close together during heat treatment because this can adversely affect the cooling rate of the dies, resulting in differences in hardness. Recommendations regarding heat treatment will be given in the design protocol.

If consistency can be maintained significant improvements will be achieved during the development process. Note that a shape change of about 0.02 % can present a problem during the development process. It is impossible to maintain such accurate results if the hardness of the raw material, for example had a hardness deviation of 3 %.

## **4.9 Stress Concentrations**

### **4.9.1 INTRODUCTION**

Stress concentrations are present where there is a discontinuity or an abrupt change in the geometry of the material. High localized stresses are caused in the vicinity of the stress concentration. These high localized stresses can cause the dies and punches to fail prematurely. The severity of the stress concentrations should be reduced to increase die life.

### **4.9.2 STRESS CONCENTRATION CONSIDERATIONS**

When a force is applied the maximum stress at the stress concentration can be 3 to 5 times higher than the nominal stress present in the rest of the die. This will cause the die to fail at a force much lower than expected. This high localized stress is raised even further at one edge of the die because the coining dies are never perfectly parallel during coining.

Die life can be improved by removing or by reducing stress concentrations present in the die. It is not always possible to remove a stress concentration and therefore this discussion will concentrate on the reduction of the stress concentrations and the effect thereof.

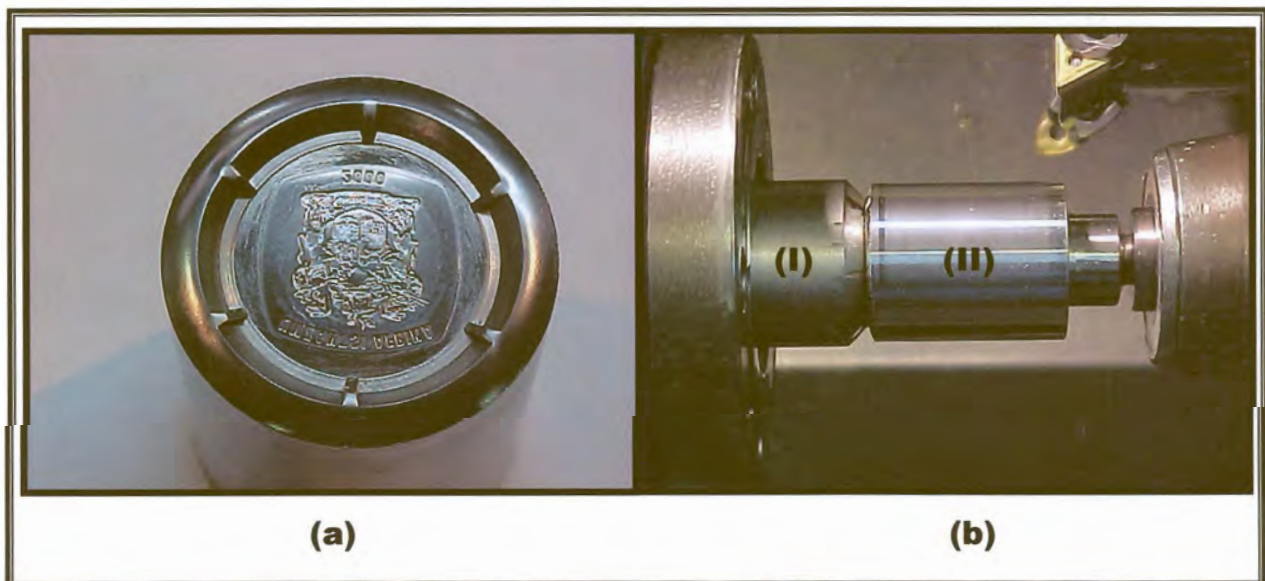
After hobbing the master punch is set up in the lathe and the punch is turned to the drawing specifications shown in Appendix C. The body of the punch is also turned so that it is concentric with the design. The master punch is removed from the lathe and locating slots are machined into the punch. These slots can be seen in Figure 4.39. The purpose of the slots is to locate the master punch on the coining dies when they are manufactured.





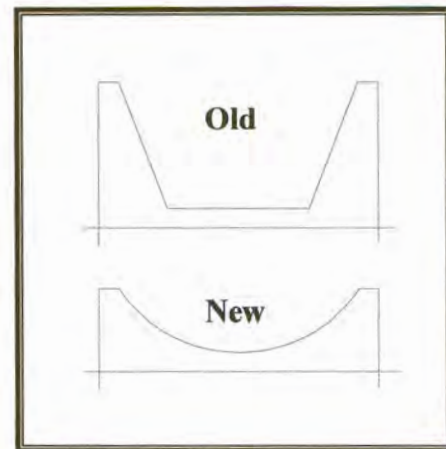
**FIGURE 4.39 Master Punch Slots**

When the master punch is hobbled on the coining die, the slots are transferred to the die (See Figure 4.40(a)). The die is now located on the master punch in the CNC lathe and the body of the die is turned (See Figure 4.40(b)). This process ensures that the design of the die is concentric with the body of the die. Failure of the master punch often occurs by crack propagation along a plane parallel to the longitudinal axis. The crack initiation site is often in the corner of one of the slots.



**FIGURE 4.40 (a) Slots transferred to coining die. (b) Master punch fixed in lathe chuck (I), Coining die located on master punch (II)**

These slots introduce a large stress concentration into the master punches. By modifying the shape of the slots the severity of the stress concentration can be reduced. Currently there is no specification for the slots and therefore the shape of the slots cannot be accurately evaluated. The slots should have a semi-circular shape and the depth of the slots should be decreased as much as possible. The reduction in depth and edge sharpness will reduce the stress concentration intensity. A specification should be set up for the new slot design. The proposed shape of the slots can be produced with a ball-nose cutter with a large tip radius. The current and suggested slot shapes are shown in Figure 4.41.



**FIGURE 4.41 Slot Shapes**

Another stress concentration point that is of major concern is on the coining dies. The point under discussion is the bottom end of the die neck as shown in Figure 4.42. According to the coining die drawing (Appendix C), there is no specification for a radius where the die neck and the body meets. During the manufacturing process a sharp edge is created at the bottom of the die neck. This causes the formation of a large stress concentration. During the investigation of die failures, a large number of failures could be attributed to crack initiation at the point of high localized stresses.

Introducing a radius in this area can reduce this stress concentration drastically. A minimum radius of 5 mm is suggested (See Figure 4.43). The transition from the die body to the die neck should be very gradual and smooth. A great improvement in die life will be observed if this stress concentration is reduced.



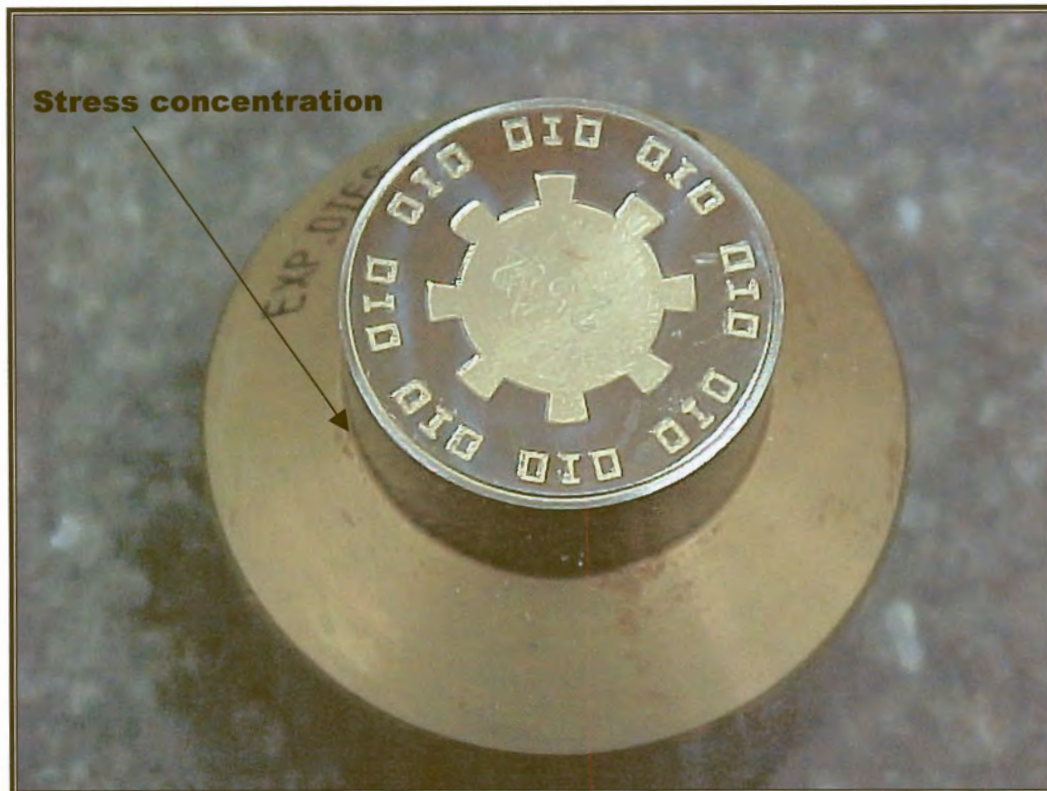


FIGURE 4.42 Stress concentration on coining dies.

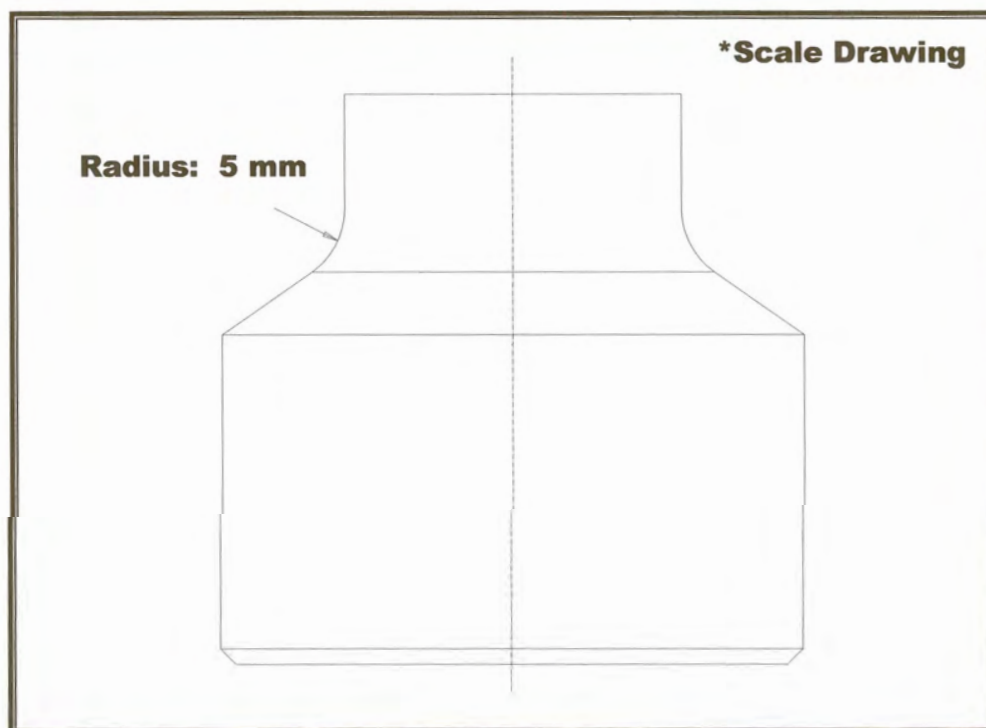


FIGURE 4.43 Coining die modification.



## REFERENCES

1. Karl-Erik Thelning, **Steel and its heat treatment**, Butterworths, 1984, p. 581-604
2. ASSAB, **Calmax Material Specification**, pg. 4
3. ASSAB, **Viking Material Specification**, pg. 5