

1 Introduction

The aim of this research project is the investigation of **factors governing the stability of stope panels in hard rock mines** in order to **define a suitable design methodology** for shallow mining operations. Most modern rock mass classification systems assess and rate the factors affecting the stability/instability of rock masses surrounding underground excavations and make support recommendations. It is for this reason that, for many years, rock mass classification systems have formed the basis of rock engineering design of mining methods, optimum excavation dimensions, and support requirements for shallow mines.

During the course of the research project, it was realised that stope panel instability in shallow mines is often controlled by geological structures. Structurally controlled failures such as beam, block and wedge failures cannot be analysed adequately using rock mass classification approaches. Thus, although rock mass classification should form a fundamental part in the process of designing stable stope panels, particular emphasis should be placed on identifying the most likely failure planes and potential modes of failure. Appropriate analysis should then be carried out in order to assess the stability of stope panels. It is for this reason that the research project includes structurally controlled analysis techniques such as beam and wedge analyses.

The design methodology proposed in this dissertation identifies the factors governing the stability/instability of stope panels. It is recommended that the proposed design methodology be considered during all stages of the mining process, from pre-feasibility to final design and implementation, and when compiling codes of practice to combat rockfall accidents in shallow mines.

This research deals specifically with shallow mining conditions in hard rock mines. The shallow hard rock mining sector comprises a heterogeneity of types of mines, which exploit a variety of orebody geometries and employ a wide range of mining methods. Therefore, the proposed design methodology for stable stope panels provides procedural guidance for all circumstances and utilises all relevant information for the design of stable stope spans.

The potential impacts which are expected from implementing the results from this research are:

- improved safety when working in shallow underground stopes;
- a systematic design approach to stope panel design;
- design of optimum panel lengths based on actual rock mass conditions;
- improved guidelines for the compilation of a code of practice to combat rockfall accidents in shallow mines;
- improved codes of practice to combat rockfall accidents in shallow mines;
- reduced probability of production losses due to panel collapses;
- identification of critical factors governing stability.

1.1 Problem statement

Instability in stope panels in near-surface and shallow mines in principle manifests itself as rockfalls from the hangingwall. Rockfalls from unstable stope panels vary in size from rockfalls between support units, to rockfalls spanning between pillars or solid abutments, to rockfalls bridging several panels and pillars. A suitable and reliable design methodology for stable stope panels at shallow depths is therefore required. This methodology must consider all manifestations of instability in stope panels and take account of the factors governing the stability/instability.

Very few mines design stope panels according to a systematic design procedure or methodology. Rock mass characterisation, estimation of rock mass properties, identification of potential failure modes, appropriate

stability analyses and other elements of the rock engineering design process are often neglected. Instead, panel lengths are often dictated by the equipment in use and by previous experience under similar conditions. Consequently, stope panel collapses occur on most near-surface and shallow mines. These incidents pose a threat to the safety of underground workers and to the economic extraction of orebodies. Hence, a methodology for the rock engineering design of stable stope panels between pillars is of vital importance for optimum safety and production in shallow mining operations.

1.2 Objectives of this study

1.2.1 Main objectives

The main objectives of the research project are to:

- investigate the factors governing the stability/instability of stope panels; and,
- define a suitable design methodology for near-surface and shallow mining operations.

Using this methodology, rock mechanics practitioners and mine planners should be able to identify and quantify the critical factors influencing the stability of stope panels. The critical factors should then be used as input to the design of stable stope panels that will provide the necessary safe environment for underground personnel working in stopes.

1.2.2 Secondary objectives

The secondary objectives of the research project are:

- Review relevant literature on stope panel and support design at shallow depth;
- Review and assess current rock mass classification systems;
- Visit selected mines (tabular and massive) to obtain information on

panel collapses, and to assess the influence of support systems and the applicability of rock mass classification systems;

- Identify hazards and assess the risks associated with instability of stope spans;
- Analyse data obtained from mines and appropriate case histories of hangingwall collapses and determine the influence of different parameters.

1.3 Research methodology

1.3.1 Research context

Stope panel instability could be defined as one or more of the following:

- local or in-stope instability, mainly due to incorrect type, strength or spacing of support units;
- major instability over a large area of the panel, mainly due to rock mass failure or structurally controlled instability;
- instability involving a few pillars, mainly due to instability of the inter-panel pillars.

Investigation of factors governing local instability between support members and the performance of individual support elements, and investigation of factors governing regional instability due to inter-panel pillar instability have been the topics of previous research projects and are not studied as part of this project. **Therefore, the main focus of this research is major in-panel instability, i.e. what spans between pillars will be stable given the geotechnical conditions?**

1.3.2 Research approach

Literature review and evaluation of rock engineering design methods

Literature pertaining to stope panel and support design, rock mass classification systems, and design methodologies has been evaluated during the course of the research project and is presented in Section 2 of the dissertation. The focus has been on the identification of key aspects influencing the stability of stope panels, and the pros and cons of different design approaches.

A review of research carried out by Joughin *et al* (1998) showed that shallow mines with tabular orebodies, in particular chrome mines, have a relatively high risk of rock fall accidents. It was therefore decided to pay special attention to the stability of panels found in chrome mines.

Data collection from selected mines

Nine mines with different orebody geometries (tabular, massive and pipe) were identified and visited during the second part of this study. The aim was to visit stable and unstable stopes under different geotechnical conditions and to assess the influence of factors governing the stability of stope panels. Detailed mapping and borehole core logging were carried out in order to classify the rock mass according to three different rock mass classification systems. The opinions of mine rock mechanics personnel on the design of stope panels under different geotechnical conditions were also obtained during the mine visits. Data collection from selected mines is described in Section 3 of the dissertation.

Risk assessment

Information obtained from SAMRASS records, the literature survey carried out, and the information obtained during visits to selected mines were used to identify significant hazards and assess the significant risks relevant to the stability of stope panels. This approach was followed in order to identify all the factors that could affect the stability of stope panels in a logic and systematic way. The risk assessment part of the study is discussed in Section 4 of the dissertation.

Stability analyses

The rock mass classification data was used to assess and back-analyse the stability of some stope panels visited during the data collection stage of the project.

The rock mass classification data was also used to estimate rock mass properties for use during the analytical design stage. Beam and wedge analysis programs were then used to assess the stability of structurally controlled stope panels. The application of different design approaches is discussed in Section 5.

Proposed design methodology for stable stope panels

The proposed design methodology for stable stope panels is presented in Section 6. This methodology takes into account the special nature of rock as an engineering material and incorporates the current knowledge base. It provides procedural guidance for the design of stope spans subject to all potential failure mechanisms.

Conclusions

The conclusions drawn from this study are summarised in Section 7.

2 Literature review and evaluation of rock engineering design methods

The design methods which are available for assessing the stability of slope panels can be broadly categorised as follows:

- empirical methods;
- analytical methods;
- observational methods.

Empirical methods, for example, assess the stability of slope panels by the use of statistical analysis of underground observations. Engineering rock mass classifications are the best known empirical approach for assessing the stability of slope panels. Empirical design methods are reviewed and evaluated in Section 2.1.

Analytical methods involve the formulation and application of certain conceptual models for design purposes. The aim is to reproduce the behaviour and response of the slope panel. This design method is reviewed and evaluated in Section 2.2.

Observational methods rely on actual monitoring of ground movement during excavation to detect measurable instability, and on the analysis of the observed ground-support interaction. This approach is the only way to verify the expected performance of excavations designed using the other two methods. Observational methods are discussed in Section 2.3.

Different engineering and rock engineering design methodologies are reviewed in Section 2.4. The proposed design methodology for stable slope spans is based on the design process described by Bieniawski (1984).

2.1 Literature review and evaluation of empirical design methods

2.1.1 Introduction

Empirical design can be defined as experienced-based application of known performance levels. It is believed that empirical design of stope spans is the most predominant design approach. Rock mass classification methods form the formal part, and engineering judgement based on experience, the informal part of empirical design of stope panels.

Rock mass classifications relate practical experience gained on previous projects to the conditions anticipated at a proposed site. They are particularly useful in the planning and preliminary design stages of a rock engineering project but, in some cases, they also serve as the main practical basis for the design of complex underground structures.

Although rock mass classifications have provided a systematic design aid, modern rock mass classifications have never been intended as the ultimate solution to design problems, but only as a means towards this end. According to Bieniawski (1989), modern rock mass classifications were developed to create some order out of the chaos in site investigation procedures and to provide the desperately needed design aids. They were not intended to replace analytical studies, field observations and measurements, nor engineering judgement. Hence, **rock mass classification should be used in conjunction with observational methods and analytical studies to formulate an overall design rationale compatible with the design objectives and site geology.**

According to Bieniawski (1989), the objectives of rock mass classifications are:

- To identify the most significant parameters influencing the behaviour of a rock mass.

- To divide a particular rock mass formation into areas of similar behaviour, that is, rock mass classes of varying quality.
- To provide a basis for understanding the characteristics of each rock mass class.
- To relate the experience of rock conditions at one site to the conditions and experience encountered at others.
- To derive quantitative data and guidelines for engineering design.
- To provide a common basis for communication between engineers and geologists.

All modern rock mass classification systems describe rock masses by considering various parameters together. The parameters most commonly employed are:

- rock material strength – this constitutes the strength limit of the rock mass;
- rock quality designation, RQD;
- spacing of discontinuities;
- condition of discontinuities (roughness, continuity, separation, joint wall weathering, infilling);
- orientation of discontinuities;
- groundwater conditions;
- in situ stresses.

Rock mass classification schemes have been developed for over 100 years since Ritter (1879) attempted to formalise an empirical approach to tunnel design, in terms of support requirements. The earlier systems used to describe rock masses in terms of their engineering behaviour were largely descriptive and rarely considered more than one of the parameters that influence the behaviour of a rock mass. These qualitative systems were usually only applicable to one rock mass type.

The development of rock mass classification/rating systems and their application to mining from 1946 to 1993 can be illustrated by the flowchart in Figure 2-1 developed by Stewart and Forsyth (1995). This flowchart,

although not complete, illustrates the contributions of most rock mass classification/rating systems. Pertinent aspects of the rock mass classification/rating systems reviewed as part of this study are summarised in the following sub-sections. The reader is referred to relevant textbooks on rock mass classification systems, e.g. Bieniawski (1989), for a more detailed description of the different systems.

Of the rock mass classification systems reviewed, four systems could be considered for evaluating the stability of slope panels. These systems are:

- The Geomechanics Classification or Rock Mass Rating (RMR) system developed by Bieniawski (1973).
- The Norwegian Geotechnical Institute (NGI), rock quality index or Q-system developed by Barton et al (1974).
- The Mining Rock Mass Classification or Modified Rock Mass Rating (MRMR) system originally developed by Laubscher (1977). This system is a modification to the RMR system.
- The Modified Stability Graph Method through the use of the Modified Stability Number, N' , originally developed by Mathews et al (1981).

These systems are discussed in more detail in Sections 2.1.8 to 2.1.13.

In Section 2.1.14, other rock mass classifications, which had an influence on the research described in this dissertation, are reviewed and evaluated. Conclusions drawn from reviewing rock mass classification systems are summarised in Section 2.1.15. The influence of the literature reviewed on the approach to the research project is discussed in Section 2.1.16 of the dissertation.

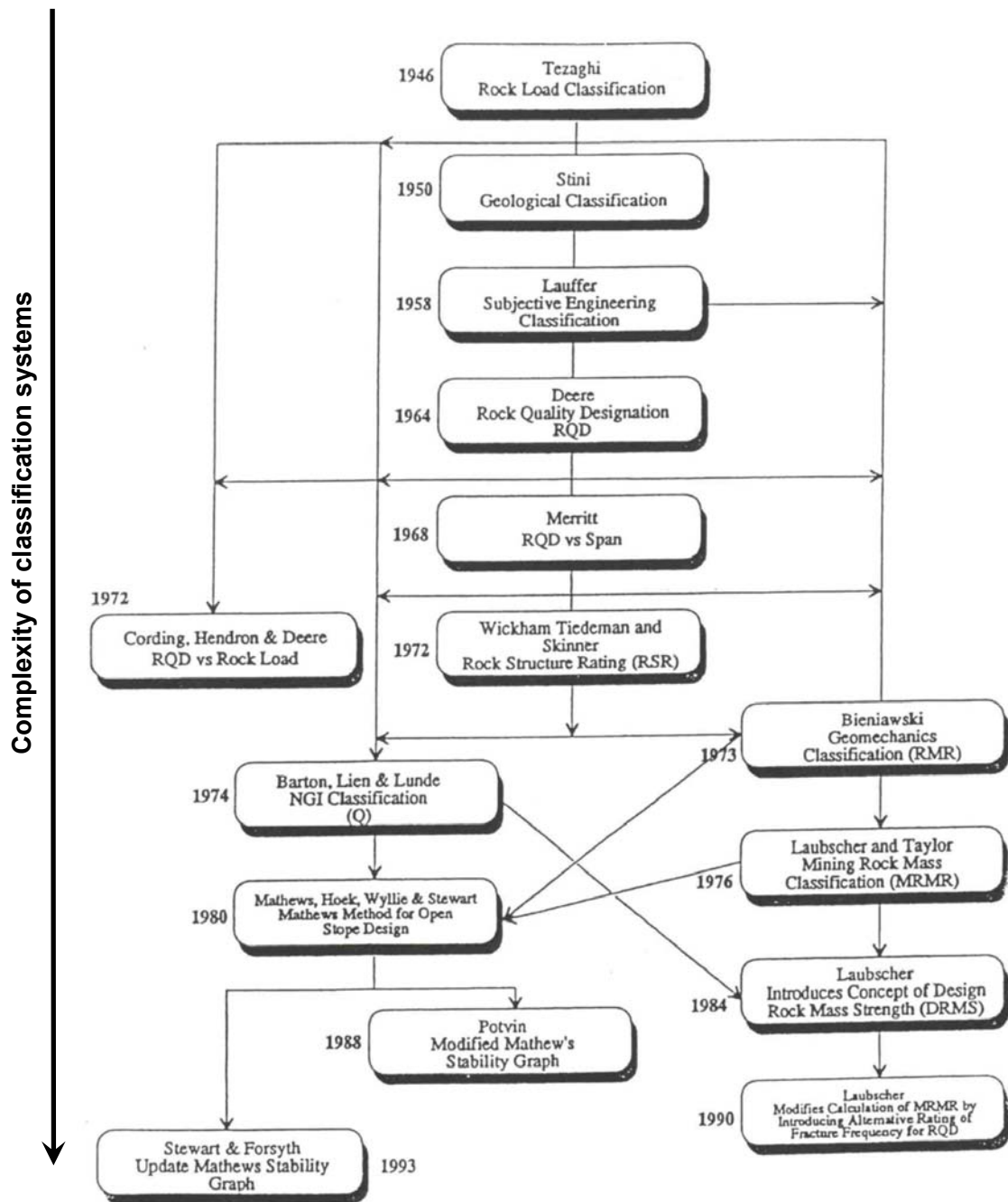

Figure 2-1 Flowchart showing the development of rock mass classification/rating systems and their application to mining from 1946 to 1993 (after Stewart and Forsyth, 1995)

2.1.2 Terzaghi's Rock Mass Classification

Terzaghi (1946) used a rock mass classification system for the design of tunnel support in which rock loads carried by steel sets were estimated based on a descriptive classification. This is considered the first rational classification system in rock engineering.

In this descriptive system, he highlighted the characteristics that dominate the behaviour of the rock mass. He included clear concise descriptions with practical comments that present the engineering geological information most useful to engineering design.

2.1.3 Stini's classification system

Stini (1950) is considered the father of the "Australian School" of tunnelling and rock mechanics. He emphasised the importance of structural defects in rock masses.

2.1.4 Lauffer's classification system

Lauffer (1958) proposed that the stand-up time for an unsupported span was related to the quality of the rock mass in which the tunnel was excavated. In tunnelling, the unsupported span refers to the span of the tunnel or the distance between the face and the nearest support. Lauffer's work has been modified by several authors, most notably Pacher *et al* (1974) and now forms part of the New Austrian Tunnelling Method (*NATM*).

2.1.5 The New Austrian Tunnelling Method (*NATM*)

Although Lauffer's classification system and the New Austrian Tunnelling Method (*NATM*) are listed as a rock mass classification methods, they should be regarded as a stand-up time classifications only.

The *NATM* includes techniques that can be implemented to measure the stability of the excavation, when the stand-up time is limited before failure occurs. It is most applicable to soft or poor rock conditions and consequently has been used successfully in the excavation of tunnels in these rock conditions throughout the world. In South Africa, most mining is done in hard rock, and application of the *NATM* is restricted because a prudent assumption in designing in hard rock is often that stability is not time dependant.

2.1.6 Rock Quality Designation Index

Rock Quality Designation index (*RQD*) (Deere *et al*, 1967) was developed to provide a quantitative estimate of rock mass quality from drill hole core. *RQD* is defined as the percentage of intact *NX* sized core pieces longer than 100 mm in the total length of the core run and is calculated as follows:

$$RQD = \frac{\text{Length of core pieces} > 10\text{cm length}}{\text{Total length of core run}} \times 100\% \quad (2.1)$$

It is important that only the natural fractures are considered and not fractures induced by the drilling process.

Where no drill core is available, *RQD* can be estimated from inspection of exposed rock surfaces by determining the number of unhealed joint planes per m³ of rock. This may be done by counting the relevant number of joint planes (excluding blast fractures) which cross a 2 to 3 m length of tape held against the excavated wall. The number of joint planes divided by the relevant sample length gives the number of joints per metre. This process is then to be repeated for two additional directions. The sum of these three values gives J_v , the number of joints per m³, and hence *RQD* from the equation suggested by Palmström (1982):

$$RQD = 115 - 3,3J_v \quad (2.2)$$

where:

J_v = the volumetric joint count or the sum of the number of joints per unit length for all joint sets.

Alternatively, J_v can be calculated by using the inverse of the representative true spacings for each joint set as follows:

$$J_v = \frac{1}{S_1} + \frac{1}{S_2} + \frac{1}{S_3} \quad (2.3)$$

where:

S_1 , S_2 and S_3 are the mean joint spacings for the three major joint sets.

It is generally found that Equation 2.1 slightly over estimates the *RQD* rating.

The following conclusions can be made regarding the *RQD* index:

- *RQD* is significantly influenced by the orientation of the borehole, and the value can vary significantly for the same rock mass depending on the borehole orientation. Therefore, care should always be taken when assessing a rock mass in terms of *RQD*. Despite this limitation, *RQD* has been included into almost all of the subsequent rock mass classification systems to account for the joint spacing and joint frequency.
- The *RQD* is a measure of drill core quality or fracture frequency, and disregards the influence of joint tightness, orientation, continuity, and infilling. Consequently, the *RQD* does not fully describe a rock mass.

2.1.7 Rock Structure Rating (*RSR*)

Wickham *et al* (1972) described a quantitative method for describing the rock mass and for selecting appropriate support on the basis of their Rock Structure Rating (*RSR*) classification. The application of this classification system is very limited, as it has been developed for relatively small diameter tunnels with steel set support. Despite this limitation, it demonstrates the principles of using a rating concept to develop a quasi-

quantitative rock mass classification system, and more significantly, the use of the classification system to design the support of the excavation.

Essentially the *RSR* system rates a variety of parameters to arrive at a numerical value.

$$RSR = A + B + C \quad (2.4)$$

where:

- A* - refers to the rock type (based on origin) and strength of the rock mass (rock hardness and geological structure);
- B* - refers to the influence of the discontinuity pattern with regard to the direction of drive (based on joint spacing, joint orientation and direction of tunnel);
- C* - refers to the influence of ground water and joint condition on the rock mass (based on overall rock mass quality, joint condition and amount of water inflow).

This system makes very crude estimates of support requirements particularly in terms of rock bolts and shotcrete, as they are based on very simplistic theoretical arguments and few historical cases. Although this is not a widely used classification system, it played a significant role in the development of more sophisticated classification systems that are applicable to a variety of engineering applications.

2.1.8 Geomechanics Classification or *RMR* system

Bieniawski (1973) published the details of a rock mass classification system called the Geomechanics Classification or the Rock Mass Rating (*RMR*) system based upon case histories drawn largely from civil engineering. Consequently, the mining industry tended to regard the classification as somewhat conservative and several modifications have been proposed in order to make the classification more relevant to mining applications.

Bieniawski's (1989) rock mass rating classification (RMR_{89}) is the system that is most frequently used today. Over the years since the first publication, the system has benefited from extensions and applications by many authors throughout the world and has stood the test of time. The varied applications point to the acceptance of the system and its inherent ease of use and versatility.

The following six parameters are used to classify the rock mass using the RMR_{89} system.

1. Uniaxial compressive strength (UCS) of rock material
2. Rock Quality Designation (RQD)
3. Spacing of discontinuities
4. Condition of discontinuities
5. Ground water conditions
6. Orientation of discontinuities

In applying this classification system, the rock mass is divided into different geotechnical/structural regions and each region is classified separately. The ratings applied to each of the six parameters listed above are summed to give the final RMR rating.

Several modifications to this system have been proposed. Laubscher (1977, 1984, 1990 and 1993), Laubscher and Taylor (1976), and Laubscher and Page (1990) have described a Mining Rock Mass Rating System ($MRMR$), which modifies the basic rock mass description for joint orientation, blast damage, mining induced stress and rate of weathering. A set of support recommendations is associated with the resulting $MRMR$ value.

In using Laubscher's $MRMR$ system, it should be borne in mind that the system was originally developed for block cave mining. Subsequently, other case histories from around the world have been added to the database.

Cummings *et al* (1982) and Kendorski *et al* (1983) modified Bieniawski's *RMR* to produce the Modified Basic *RMR* (*MBR*) system for mining. This system was developed for block caving operations in the USA. The *MBR* system adjusts the *RMR* system for blast damage, induced stresses, structural features, distance from the cave front and size of caving blocks. Support recommendations are presented for isolated or development drifts. This system is not used significantly today.

Bieniawski (1989) published a set of guidelines for the selection of support in tunnels for rock masses in which the *RMR* had been determined. These ratings relate specifically to a horseshoe shaped tunnel with a maximum span of 10 m at a maximum depth of 900 m. It is important to note that these guidelines have not been significantly revised since 1973. Consequently, fibre reinforced shotcrete may be used instead of wire mesh and shotcrete support systems.

The stability of non-stope excavations can be estimated in terms of stand-up time from the *RMR* value using the graph in Figure 2-2 (Bieniawski, 1993). Bieniawski (1976) developed this graph based on the original concept of stand-up time by Lauffer (1958). The accuracy of this stand-up time is doubtful since it is influenced by excavation technique, durability and *in situ* stress, effects which the classification system does not take into account. Therefore, this graph should be used for comparative purposes only.

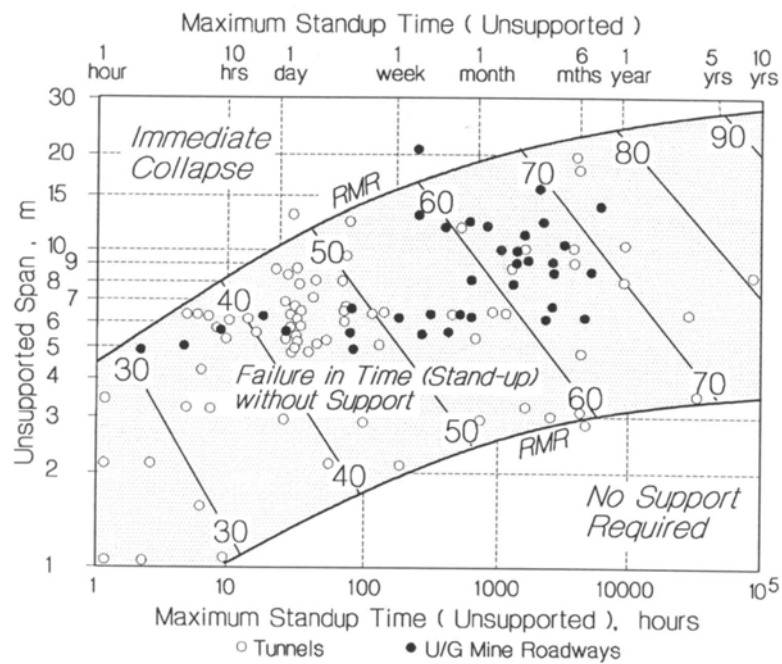

Figure 2-2 Relationship between unsupported span, stand-up time and *RMR* (after Bieniawski, 1989 and 1993)

The advantages and disadvantages of the *RMR* system are summarised in Table 2-1.

Table 2-1 Advantages and disadvantages of Bieniawski's RMR system ('89)

Advantages	Disadvantages
Well known and widely used	Not used extensively in SA mines because there is uncertainty in its application to mining excavations. Support recommendations are based on a horseshoe shaped tunnel with a maximum span of 10 m at a maximum depth of 900 m.
Adjustment for joint orientation	The joint orientation adjustments are broad categorisations and difficult to use without substantial experience. In worst cases the orientations of the joints are not considered to have a dominant influence on the rock mass behaviour.
Adjustment for the influence of ground water	In practice some of the joint conditions encountered could not be accurately described using the RMR system.
Description of joint condition in terms of continuity; separation; roughness; infill and alteration.	RQD has to be calculated using the equation recommended by Palmström. This equation may result in higher than actual RQD values being calculated.
Incorporates easily measured parameters RQD and joint spacing to account for frequency of joints or block size.	The RMR system accounts for joint frequency twice, in RQD and joint spacing. Therefore, this system is very sensitive to changes in fracture spacing.
UCS is used in the assessment of intact rock strength. This is an easily measured value and can be calculated from field point load strength measurements.	Does not consider the influence of mining induced stresses on the stability of an excavation.
Rock mass properties can be calculated from RMR	The RMR-system was developed from a civil engineering background and is conservative in terms of stoping.
	The RMR system is very insensitive to the strength of intact rock material, a parameter which is very important in the engineering behaviour of certain rock masses. (Pells, 2000)
	The RMR system does not discriminate well between different grades of rock material encountered (Pells, 2000)
	The accuracy of Bieniawski's "stand-up time" is doubtful since it is influenced by excavation technique, durability and <i>in situ</i> stress, effects which the classification system does not take into account. Therefore, this graph should be used for comparative purposes only.
	Does not consider the rate at which the fresh rock weathers when exposed to the atmosphere.

2.1.9 NGI or Q-System rock mass classification

On the basis of an evaluation of a large number of case histories of underground civil engineering excavations, most of which were supported,

Barton *et al* (1974) of the Norwegian Geotechnical Institute (NGI) proposed the Q-System rock mass classification for the determination of rock mass characteristics and tunnel support requirements. The numerical value of the index Q varies on a logarithmic scale from 0,001 to a maximum of 1 000 and is defined by:

$$Q = \frac{RQD}{J_n} \times \frac{J_r}{J_a} \times \frac{J_w}{SRF} \quad (2.5)$$

where:

RQD = the Rock Quality Designation

J_n = the joint set number

J_r = the joint roughness number

J_a = the joint alteration number

J_w = the water reduction factor

SRF = the stress reduction factor

The first quotient, *RQD/J_n*, represents the structure of the rock mass and is a crude measure of the block or particle size. The second quotient, *J_r/J_a*, represents the roughness and frictional characteristics of the joint walls or filling materials and is a crude measure of the inter-block shear strength. The third quotient, *J_w/SRF*, is a crude measure of the active stress.

Extensive research has been conducted by several authors, notably Grimstad and Barton (1993), Mathews *et al* (1981), Potvin and Milne (1992), to estimate the stability of unsupported stope spans, and to develop a system of support design based on the Q system.

Grimstad and Barton (1993) using a Q system estimated support categories in terms of equivalent dimension (*D_e*). *D_e* is an additional parameter defined by Barton *et al* (1974) where:

$$D_e = \frac{\text{Excavation span, diameter or height (m)}}{\text{Excavation support ratio (ESR)}} \quad (2.6)$$

The *ESR* is a value that is assigned to an excavation in terms of the degree of security that is demanded of the installed support system to maintain the stability of the excavation. Hutchinson and Diederichs (1996) recommend that an *ESR* not more than 3 be used for temporary mine openings.

Hutchinson and Diederichs (1996) produced a graph (Figure 2-3) illustrating the relationship between *Q* value and maximum unsupported span for different *ESR*.

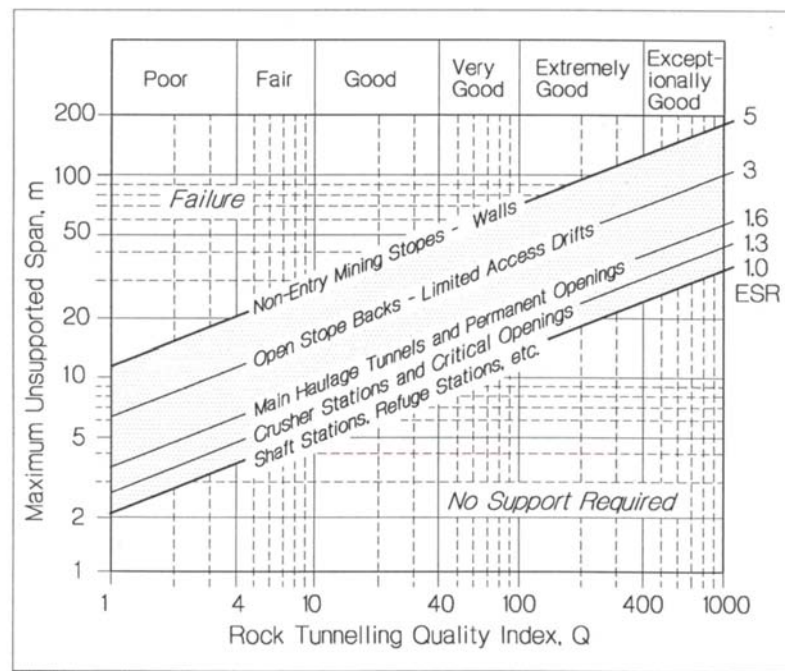

Figure 2-3 Relationship between maximum unsupported span and *Q* value

Barton *et al* (1974) provided additional information on rockbolt length, maximum unsupported spans and roof support pressures to supplement the support recommendations published in the original 1974 paper. The length, *L*, of rockbolts can be estimated as follows for the excavation width, *B*, and the *ESR*.

$$L = \frac{2 + 0,15B}{ESR} \quad (2.7)$$

The maximum unsupported span can be estimated from the following equation:

$$\text{Max span (unsupported)} = 2 \text{ ESR } Q^{0.4} \quad (2.8)$$

The advantages and disadvantages of the Q-system are summarised in Table 2-2.

Table 2-2 Advantages and disadvantages of the Q-system

Advantages	Disadvantages
Well known and well used	Perception in South Africa that it is only applicable to rock mass classification in tunnels.
Has been constantly refined for more than 20 years. The basic system, however, has remained unchanged.	Difficult to familiarise with because of the large tables. However, the system is simple to apply once a certain degree of familiarity is achieved.
Very detailed description of all ratings used for the different parameters. The process of applying the Q system focuses the attention of the user on important parameters that are often ignored during a site investigation.	The influence of joint orientation is not taken into account. In the development of stopes, which generally have larger spans than tunnels, the joint orientation significantly influences the stability of the panel. In some cases, the direction of mining is changed to increase the stability, because of the orientation of the major joint sets.
Considers the influence of mining induced stress on the stability of the excavation.	The influence of mining induced stresses is accounted for in the classification system. Therefore, care must be taken to ensure that no further adjustment is made considering this parameter.
Joint roughness and joint alteration are considered separately.	Although descriptions are very detailed in terms of joint roughness and infill, it does not take joint continuity and joint separation into account. These can have a significant impact on the strength of the joint.
Considers the influence of ground water.	The Q-system considers the condition of the joint surface as the most significant of the parameters and consequently any rock mass that has joints of low strength is rated as being very weak. In reality, the strength of the joint surface only dominates the rock mass strength if the joint is very unfavourably oriented in relation to the excavation. Since Q does not consider the orientation of the natural fractures in the rock mass, it does not give a reliable indication of how a rock mass will behave in the mining environment.
Can calculate rock mass deformability by converting Q to RMR and then calculating deformability.	The Q-system predicts non-conservative support designs for shallow workings. (Pells, 2000)
	The Q-system was developed from a civil engineering background and is conservative in terms of stoping.

2.1.10 Mining Rock Mass Rating System (*MRMR*)

Laubscher (1977, 1984), Laubscher and Taylor (1976), and Laubscher and Page (1990) have described a modified rock mass rating system for mining, *MRMR*. This system assigns a rating to the *in situ* rock mass based on measurable geological parameters. Each geological parameter is weighted according to its importance, and the total maximum rating is 100. This *in situ* rating is often referred to as the *RMR*, and is not to be confused with Bieniawski's *RMR* rating system. Laubscher's *RMR* essentially describes the same parameters as Bieniawski's classification system, but the individual parameters are weighted differently. Table 2-3 below highlights the difference in the weighting of individual parameters in each of the two rating systems.

Table 2-3 Different weighting on the input parameters in Bieniawski's (1989 and 1993) and Laubscher's *RMR* (1990).

Laubscher's <i>RMR</i> Input Parameters	Maximum Rating	Bieniawski's <i>RMR</i> Input Parameters	Maximum Rating
Intact Rock Strength (<i>UCS</i>)	20	Intact Rock Strength (<i>UCS</i>)	15
<i>RQD</i>	15	<i>RQD</i>	20
Joint spacing	25	Joint Spacing	20
Joint Condition and Ground water	40	Joint Condition Groundwater	30 15

Laubscher's *in situ* rock mass rating (*RMR*) is then adjusted to assess the behaviour of the rock mass in a specified mining environment, and the adjusted rating is referred to as the mining rock mass rating (*MRMR*). The adjustments include:

1. Weathering
2. Mining induced stresses
3. Joint orientation
4. Blasting effects

The adjusted rock mass rating (*MRMR*) can then be used to determine the support requirements for the excavation. This is achieved by using Laubscher's series of tables, in which the rating is described in terms of a rock mass class and support techniques are recommended for each class.

The classification system is versatile, and the *RMR*, *MRMR* and design rock mass strength (*DRMS*) provide good guidelines for mine design purposes. It is essential that different geotechnical zones are rated separately, as average ratings can be misleading. The weakest zone, regardless of its relative size, may in some cases determine the response of the whole rock mass.

The rock mass strength (*RMS*) is derived from the intact rock strength (*IRS*) and the *RMR*. The strength of the rock mass cannot be higher than the corrected average *IRS* of that zone. The *IRS* is obtained from the testing of small specimens, but this value has to be down rated by 80% as the strength of large specimens (such as a rock mass) is weaker than the small samples. This reduction of *IRS* does not relate to the influence of jointing on the strength of the rock mass.

$$RMS = \frac{(A - B)}{80} \times C \times \frac{80}{100} \quad (2.9)$$

where:

A = Total *RMR* rating

B = *IRS* rating

C = *IRS* in MPa

The Design Rock Mass Strength (*DRMS*) is the strength of the unconfined rock mass in a specific mining environment. The *DRMS* is the *RMS*, which has been adjusted for weathering, discontinuity orientation, water and blasting. These adjustments are the same as the adjustments applied to the *RMR* to determine the *MRMR*. The advantage of the *DRMS* is that it is calculated in terms of strength and can easily be related to the *in situ* stresses.

Laubscher has developed a Stability/Instability diagram (Figure 2-4), which is based on case studies mainly from Zimbabwe, Chile, Canada, USA and South Africa. It is used to estimate the stability of a given excavation in terms of mining rock mass rating (*MRMR*) and hydraulic radius (*HR*).

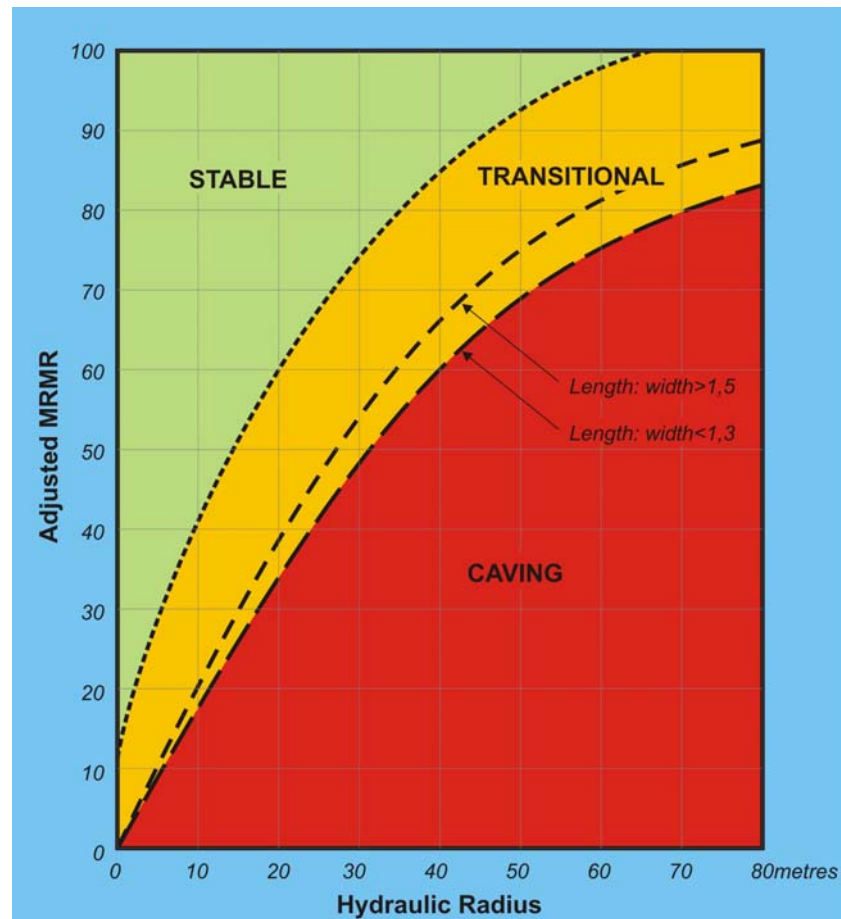

Figure 2-4 Stability diagram illustrating the relationship between *MRMR* and *HR* (after Laubscher, 2001)

The advantages and disadvantages of the Mining Rock Mass Classification system are summarised in Table 2-4.

Table 2-4 Advantages and disadvantages of the Mining Rock Mass Classification system

Advantages	Disadvantages
Designed specifically for mining and therefore does not have the inherent maximum span limitation.	Developed specifically for caving and most of the case studies on which this system is based were from the cave mining method.
Well known and frequently used in South Africa	Although joint orientation and mining induced stresses are taken into account, a certain level of experience in both the use of the classification system, and rock mechanics understanding is needed to apply these two parameters to any rock engineering application.
Based on same controlling parameters as both the <i>Q</i> and <i>RMR</i> system.	
Considers the influence of blasting on rock mass stability.	The influence of ground water on the stability of the rock mass is considered together with joint condition - implying that joint strength is the only parameter that is influenced by ground water. This is not necessarily true in the soft rock environment.
Considers the influence of joint orientation.	
The above adjustments are applied to a basic <i>RMR</i> rating based on joint condition, joint spacing and intact rock strength (note that this <i>RMR</i> rating is not the same as Bieniawski's <i>RMR</i>)	
Considers the influence of the rate at which a rock weathers once exposed to the atmosphere	
Considers the influence of mining induced stress.	
The rating is supplemented with a simple guide to excavation support.	
Can be used to calculate Design Rock Mass Strength (<i>DRMS</i>) - a parameter frequently used in the South African mining industry.	

2.1.11 Correlation between Barton's *Q* and Bieniawski's *RMR*

Bieniawski (1984) used 117 case studies involving 68 Scandinavian, 28 South African and 21 other documented case histories from the United States covering the entire range of *Q* and *RMR* to propose the following relationship:

$$RMR = 9 \ln Q + 44 \quad (2.10)$$

Other authors proposed different correlations based on different case histories.

Goel *et al* (1996) evaluated the different correlations on the basis of 115 case histories including 77 reported by Bieniawski (1984), four from Kielder Experimental tunnel report by Hoek and Brown (1980) and 34 collected from India. He concluded that the correlation coefficient of these approaches are not very reliable.

The main reason for the poor correlation is the fact that the two systems are not truly equivalent. For example, the *RMR* system does not consider the stress condition of the rock mass, while the *Q* system does not consider joint orientation and intact rock strength as independent parameters. In order to correlate the two systems more accurately, Goel *et al* (1996) suggested that:

- *SRF* = 1 be used in Barton's equation to calculate the rock mass number *N*;
- *RMR* be used without rating for joint orientation and intact rock strength to calculate the rock condition rating (*RCR*).

Goel *et al* (1996) then developed the following correlation on the basis of 63 cases: 36 from India, four from the Kielder experimental tunnel reported by Hoek and Brown (1980) and 23 NGI cases from Bieniawski (1984):

$$RCR = 8 \ln N + 30 \quad (2.11)$$

The above correlation by Goel *et al* (1996) has a satisfactory coefficient of 0,92 compared with a coefficient of 0,77 for Bieniawski's (1984) correlation.

Therefore, to calculate *RMR* from *Q*:

$$RMR = RCR + (\text{rating for } q_c \text{ and joint orientation}) \quad (2.12)$$

and, to calculate *Q* from *RMR*:

$$Q = \left(\frac{N}{SRF} \right) \quad (2.13)$$

2.1.12 Modified Rock Quality Index, Q'

The parameter SRF used to calculate the Rock Quality Index, Q , becomes redundant when the classification system is used for the estimation of rock mass properties for the purposes of analytical or numerical modelling. The influence of stress is taken into account within the model. Thus, if $SRF = 1$, the Modified Rock Quality Index, Q' , is given as:

$$Q' = \frac{RQD}{J_n} \times \frac{J_r}{J_a} \times J_w \quad (2.14)$$

$SRF = 1$ is equivalent to a moderately clamped but not overstressed rock mass.

In most underground hard rock mining environments, the excavations are relatively dry. Therefore, the parameter J_w can also be set to 1,0. In this case. The Modified Rock Quality index, Q' , then becomes:

$$Q' = \frac{RQD}{J_n} \times \frac{J_r}{J_a} \quad (2.15)$$

Q' reflects the inherent character of the rock mass independent of the excavation size and shape. Hutchinson and Diederichs (1996) therefore suggest that Q' be used to estimate rock mass properties.

2.1.13 Modified stability number, N'

The factor Q' with J_w set to 1,0 is used along with factors A , B and C to determine the Modified Stability Number, N' , which is used in the Modified Stability Graph method (Mathews *et al* , 1981; Potvin, 1988; Bawden, 1993 and Hoek *et al* , 1995) for dimensioning of open stopes in mining.

The design procedure is based on two factors; the modified stability number (N') and the hydraulic radius, HR , (area / perimeter).

The stability index is defined by:

$$N' = Q' \times A \times B \times C \quad (2.16)$$

where:

A is the rock stress factor

B is the joint orientation adjustment factor

C is the gravity adjustment factor

176 case histories by Potvin (1988) and 13 by Nickson (1992) of unsupported open stopes are plotted on the Stability Graph shown in Figure 2-5. This graph can be used to evaluate the stability of stope panels.

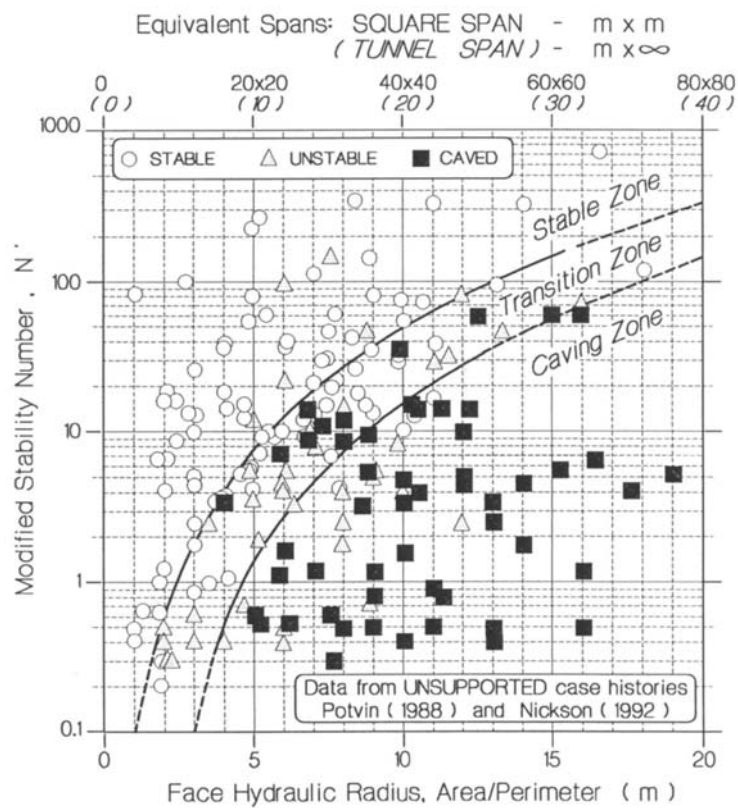

Figure 2-5 Stability Graph (after Potvin, 1988 and Nickson, 1992)

2.1.14 Review and evaluation of other rock mass classification systems

Existing rock mass classification systems are sometimes modified or new systems are developed to suit local conditions. Two examples are:

- the modified NGI system or Impala system;
- the rating system developed by the Australian Geomechanics Society;
- the 'New Modified Stability Graph' system.

Watson and Noble (1997) and York *et al* (1998), discuss modifications to the *NGI* rock mass classification system to cater for problems related to the Merensky Reef. They compared four rock mass classification systems: the Geomechanics Classification (*RMR*), *NGI*, Impala and Amandelbult systems and concluded that the Impala system, which is a modified *NGI* system, describes observed conditions most accurately but required some modifications to account for stress and discontinuity orientation and persistence. Modifications to the *NGI* system included changes to the stress reduction factor (*SRF*) and joint water factor.

Watson and Noble (1997) also produced a Panel Span Design Chart based on an analysis of stable and collapsed panels on the Merensky Reef. They concluded that there were some collapses that did not agree with their design chart and that a greater understanding of the rock mass is required. Subsequent numerical analyses by York *et al* (1998) using the universal distinct element program, UDEC (Itasca, 1991) could not show a good correlation between the numerical model and the design chart.

Pells (2000) refers to a classification system developed by the Australian Geomechanics Society (*AGS*) for assessing design parameters for heavily loaded foundations on sandstones and shales. The *AGS* system has proven to be a valuable tool for rapid communication of information on rock mass quality of the sandstones and shales between investigators,

designers and contractors, and encapsulates the key features which affect engineering performance of the rocks.

The AGS system is a five-class system based on:

- UCS of the intact rock material;
- degree of fracturing;
- the percentage cumulative thickness of sub-horizontal clay seams within the zones being assessed.
- The lowest rating of any one factor defines the class.

Watson (2004) used underground observations in conjunction with instrumentation sites to establish the strategic parameters required to describe the rock mass behaviour of shallow-dipping stopes on the Bushveld platinum mines. He evaluated existing rock mass rating systems using the observations and instrumentation results and concluded that none of the current systems adequately described all the relevant geotechnical conditions. Therefore, a hybrid of several current systems was developed, called the 'New Modified Stability Graph' system based on the method originally described by Mathews *et al* (1981) and revised by Hutchinson and Diederichs (1996).

2.1.15 Conclusions

The following conclusions can be drawn from the review of rock mass classification systems:

- The basic functions of rock mass classification systems are to:
 - subdivide the rock mass into zones of similar behaviour;
 - provide a basis for communication between various mining disciplines;
 - formulate design parameters for the actual mine design.
- Rock mass classifications are based on case histories and hence tend to perpetuate conservative practice.
- Most rock mass classification systems reviewed were oriented towards the prediction of support requirements for tunnels and permanent

structures. Also, the support recommendations proposed by the classification systems are general and have to be modified as new conditions are exposed in developing excavations.

- Rock mass classification systems are often used to characterise rock masses with a single (scalar) figure – the average rating. Two completely different rock masses could therefore have the same rating.
- Support-excavation-rock mass structure interaction and instabilities have strong positional and directional components, which cannot be characterised by a single scalar rating.
- ‘Local knowledge’ is based on feel and experience, and different engineers may apply this, and the rating system itself differently, producing non-comparable assessments for the same geotechnical area.
- Rock mass classification systems could become increasingly more complex with time because users incorporate additions and modifications to take account of conditions, which the rating system has been found to describe inadequately.
- Rock mass classification is not a rigorous analytical method, as is often assumed by users.
- Rock mass classifications represent only one type of design method, an empirical one, which needs to be used in conjunction with other design methods.
- Not one of the rock mass classification systems give realistic support recommendations for most stope panels found in the shallow hard rock mining sector and the different mines have to fall back on experience for adequate support.
- Rock mass classifications should be used throughout the mine life as an integral part of the design process.
- The reliability of the main classification systems is questionable under certain conditions (Pells, 2000 and Watson, 2004). The reason for this is that, although the main classification systems consider similar parameters in calculating the final rock mass ratings, different systems apply different weighting to similar parameters and some include distinct parameters that influence the final rock mass quality rating. It is therefore important that:

- at least two rock mass classification systems be used when classifying rock;
- rock mass classification systems be used within the bounds of the case histories from which they were developed.
- Bieniawski's *RMR* places greater emphasis on the spacing of structural features in the rock mass, but does not take the mining-induced rock stress into account. The *Q*-system, does not consider joint orientation, and only considers the joint condition (alteration and infill) of the most unfavourable joints. Therefore, the *Q*-system assumes that the rock mass strength is dominated by the strength of the weakest joint. Both of these classification systems suggest that the orientation and inclination of the discontinuities are not as significant as one would normally assume, and that a differentiation between favourable and unfavourable are adequate for practical purposes. This assumption is not necessarily true for all engineering applications. In the case of mining, the orientations of the discontinuities have a significant influence on the stability of the excavation. The *MRMR* system has adjustments for both the orientations of discontinuities and the influence of mining induced stresses in the rock mass. These two adjustments result in the *MRMR* classification system being well suited to a mining environment.
- When dealing with extremely weak ground, both the *MRMR* and Bieniawski's *RMR* classification systems are difficult to apply. This is largely because both were developed for the hard rock environment. In the case of squeezing, swelling or flowing ground, the use of the *Q*-system may be more applicable.
- *RMR* may overrate the strength of a rock mass, which has moderately spaced joints but the joint themselves have a very low strength. The exclusion of a stress reduction factor from this classification system severely limits the application of the system to the mining environment where the stress environment changes as mining proceeds.
- Laubscher's *MRMR* system (1990) has found more general application in mining.
- Care should be taken not to:
 - average numbers obtained from field measurements across geotechnical domains;

- loose sight of the characteristics and behaviour of the rock mass;
- not to express individual parameters as single values, but rather as a distribution;
- Jointing can have a major effect on the behaviour of the rock mass. Deformation and failure will take place preferentially along the joints. Often, one or two of the joint sets are dominant, and the implications are that both rock mass deformation and rock mass failure will be directional. This is not taken into account in the main rock mass classification approaches, which applies more to homogeneous rock mass behaviour.
- It is unlikely that there will ever be a universal rock mass classification system that will be able to cater for all the possible situations found in the shallow hard rock mining sector.

2.1.16 Discussion

The stability of stope panels can be evaluated by using one or more of the following graphs:

- Bieniawski's graph (1989, 1993) illustrating the relationship between RMR and unsupported span. (Figure 2-2) ;
- Hutchinson and Diederichs's graph (1996) illustrating the relationship between Q and unsupported span (Figure 2-3);
- Laubscher's Stability diagram, which correlates the adjusted MRMR with the hydraulic radius (Figure 2-4);
- Potvin's Stability Graph method (Figure 2-5), illustrating the relationship between the Modified Stability Number, N' , and hydraulic radius.

The applicability of the above rock mass classification systems to the design of stable stope spans for shallow hard rock mines is assessed in Section 5

Rock mass classifications tend to be conservative and should be considered for assessing stable stope spans during pre-feasibility phases only. However, rock mass classification systems could also be optimistic. Therefore, more certainty is required for assessing stable stope spans for

feasibility study purposes. Hence, appropriate stability analyses based on more accurate data should be used to assess anticipated failure modes and mechanisms. Analytical design methods are discussed in Section 5

The tendency is to characterise rock masses using a single number based on average rock mass conditions. Assuming worst case parameters may prove impractical from an economic perspective while designing based on the best possible conditions would clearly be imprudent. In order to understand the consequences of this variability at a given site, it is useful to tabulate reasonable ranges for the input parameters (one standard deviation) and then calculating an expected range of stable stope spans. This method could be expanded to involve probabilistic methods similar to those outlined in Hoek et al (1995) and Harr (1987).

In the classification system described by Pells (2000), the lowest rating of any factor defines the class. This concept highlights the important contribution of only one parameter with a low rating forming the proverbial weak link in the chain. This concept described by Pells (2000) was used to develop a simple but comprehensive hazard rating system including rock mass and support parameters that can be used by mines to assess stope stability on a local and regional scale. The system is discussed in Appendix A.

It should be noted that the ratings for the different categories in the proposed rating system should be summed for comparative purposes only. Of importance is the fact that any identified hazard should be highlighted and not be allowed to be disguised by other 'good' ratings. The following rules should therefore apply:

- All panels with sub-categories rated as *1 should be declared as "Special Areas"
- All panels with sub-categories rated as 2 should be declared as "Moderate Areas"
- All panels with sub-categories rated as 3 or 4 should be declared as "Good Areas"

2.2 Literature review and evaluation of analytical design methods

2.2.1 Introduction

Analytical methods include such techniques as closed form solutions, numerical methods and structural analysis. They are effective in designing slope panels because they enable comparative assessments of the sensitivity of slope panel stability for varying input parameters. It is important that analytical methods and failure criteria be selected that can model the anticipated or identified failure mechanism and mode of failure most appropriately. However, no model can accurately model failure. Therefore, as for the empirical design methods, it is important that more than one analytical design approach be used so that an understanding can be gained of the likely failure zones and extent of failure.

The following analytical design categories have been evaluated as part of the project:

- Design of stable slope panels in stratified or bedded rock using beam-type analyses.
- Design of stable slope panels in blocky ground using keyblocks or wedge-type analyses.
- Design of stable slope panels in massive rock using numerical stress analyses and comparison with appropriate failure criteria.

These analyses are discussed in Sections 2.2.2 to 2.2.3.

2.2.2 Beam Type analyses

Mining in stratified rock masses or rock masses with pseudo stratification is common. Such “stratification” is not only the result of sedimentary layering but can form through excavation-parallel stress fracturing of massive

ground or can be the result of fabric created through igneous intrusion/extrusion or metamorphic flow processes.

This structure is an important factor in the consideration of stability of the roof of excavations in such rocks. Two important factors influence the behaviour of a laminated roof: firstly that the tensile strength perpendicular to the laminations is very low or zero and secondly that the shear strength on these laminations is very low compared to the shear strength of the intact rock. It is, however, possible for the rock in the roof to span the excavation by forming a rock beam. Beam analyses include elastic and Voussoir beam analyses. Evaluation of elastic and Voussoir beam analysis is discussed in the following sub-sections.

Elastic beam analysis

The elastic theories assume that the rock above the excavation acts as a series of elastic beams or plates loaded by self-weight and the roof span is designed so that an allowable stress is not exceeded in these beams or plates. In investigating the flexural behaviour of the immediate roof, the following assumptions are made:

- each stratum is homogeneous, elastic and isotropic;
- there is no bonding between the strata, i.e. bedding surfaces have parted and friction and cohesion are zero;
- each stratum is subjected to a uniform loading in both the transverse (due to self-weight) and axial (due to horizontal stress) directions simultaneously;
- when the upper stratum loads onto the lower stratum, the deflections of the two strata are equal at each point along the roof span and:
 - the upper beam loads the lower beam with a uniform load per unit length of beam,
 - the lower beam supports the upper beam with an equal load per unit length.
- all strata are the same length and width.

Thin beams, $T < L/5$, can be adequately approximated by a beam of unit width loaded uniformly along its upper surface with a load of:

$$q = \gamma \cdot T = \rho \cdot g \cdot T \quad (2.17)$$

where:

q = uniform load per unit width of beam (N/m² or Pa)

γ = unit weight (N/m³)

T = thickness of loose stratum (m)

ρ = density of rock stratum material (kg/m³)

g = gravitational acceleration (9,81m/s²)

L = length of beam or bord width (m)

(Thick beams, $T > L/5$, cannot use simple loading equivalents of body weight since they perform differently due to a shift in the position of the neutral axis during bending which results in a non-symmetrical stress distribution across the beam.)

The basic equations governing the behaviour of a thin beam of rectangular cross section with fixed, or built-in ends, acted upon by a distributed load per unit length are equations for deflection, η , bending moment, M , and shear force, W . These equations are:

$$\eta = \frac{q \cdot x^2}{24 \cdot E \cdot I_y} (L - x)^2 \quad (2.18)$$

$$M = -\frac{q}{12} (6 \cdot x^2 - 6 \cdot L \cdot x + L^2) \quad (2.19)$$

$$W = q \left(\frac{L}{2} - x \right) \quad (2.20)$$

Where the moment of inertia of the cross-section, I_y , of a rectangular beam of unit width and thickness t is:

$$I_y = \frac{T^3}{12} \quad (2.21)$$

The maximum deflection at the centre of the beam, $(\eta)_{max}$, the maximum shear forces at the abutments of the beam, W_{max} , and the bending moments at the centre, $M_{(x=L/2)}$, and abutments of the beam, M_{max} , are:

$$(\eta)_{max} = \frac{\rho \cdot g \cdot L^4}{32 \cdot E \cdot T^2} \quad (2.22)$$

$$W_{max} = \frac{\rho \cdot g \cdot L}{2} \quad (2.23)$$

$$M_{max} = -\frac{\rho \cdot g \cdot L^2}{12} \quad (2.24)$$

$$M_{(x=L/2)} = \frac{\rho \cdot g \cdot L^2}{24} \quad (2.25)$$

Axial stresses, σ_x , (also called the fibre stress) are tensile and compressive in the cross-section through a beam at the bottom and top of the beam respectively. They reach a maximum at the end of the beam and are given by:

$$\sigma_{x(max)} = \frac{\pm 6 \cdot M}{T^2} = \frac{\pm \rho \cdot g \cdot L^2}{2 \cdot T} = \frac{\pm \gamma \cdot L^2}{2 \cdot T} \quad (2.26)$$

The shear stress, τ_{xy} , on a transverse cross-section through a beam is a maximum at the end of the beam. It is given by:

$$(\tau_{xz})_{max} = \frac{3 \cdot W}{2 \cdot t} = \frac{3 \cdot q \cdot L}{4 \cdot t} = \frac{3 \cdot \rho \cdot g \cdot L}{4} \quad (2.27)$$

According to Equation 2.27, relative movement along the interfaces of different roof strata is likely to occur close to the ends of the beam. Because the shear stresses in the centre of the roof beam is zero, roofbolts installed at the centre of the panel contribute little to the formation of a composite beam.

The above equations highlight the importance of the thickness and span of a beam on the maximum deflection of the beam and the horizontal stresses at the end of the beam. For example, if the effective thickness of a roof beam comprising of four individual layers of thickness $T/4$ can be increased to a total thickness T by roof bolting, then the maximum deflection of the

bolted beam is 1/16th and the maximum horizontal stress is ¼ of the four member beam. Also, by reducing the panel span from L to $L/4$, the maximum deflection of the beam is 1/256th and the maximum horizontal stress is a 1/16th of a full length beam. Therefore, controlling the panel span is the most effective means of controlling the roof without artificial means.

From the above equations the ratio of maximum axial (tensile) to shear stress is given by the relationship:

$$\frac{\sigma_{x(max)}}{\tau_{xy(max)}} = \frac{2 \cdot L}{3 \cdot T} \quad (2.28)$$

Therefore, where the beam is thin, $L/T > 5$, the ratio of tensile to shear stress will be greater than 3, and the beam will primarily fail in tension. For thick beams, $L/T < 5$, the beam will primarily fail in shear.

The failure criterion to evaluate the stability of the immediate roof is the maximum stress theory. This requires consideration of failure in tension and compression.

The above principle could be applied to rockbolting support as well. For example, if we consider the rock between adjacent rockbolts distance L apart, then it can be seen that:

- reduction in spacing will reduce the L/T ratio and dramatically reduce the stress;
- increasing the thickness, T , by creating a composite beam will have a beneficial effect, but not as dramatic as a reduction of spacing.

According to the elastic beam theory, the most likely failure mechanism is in tension. Therefore, the tensile strength of elastic beams, which is approximately 1/10th to 1/20th of the uniaxial compressive strength, should be compared with Equation 2-26.

Discussion – Elastic beam analyses

Elastic beam theory is useful in explaining the deformation and failure of the mine roof in bedded deposits and can be used to design safe stope panels if the limitations of the theory are appreciated. If, however, sub-vertical joints are present in the roof, the tensile strength of the rock beam will be zero. A stable roof beam will only form if a stable compression arch can develop. The Voussoir beam theory recognises the fact that in a confined situation the ultimate strength of a beam is greater than its elastic strength and that pre-existing cross fractures may not allow tensile stresses. The Voussoir beam theory thus assumes that the beam consists of a non-tension material and carries its own weight by arching. This theory will be evaluated in detail in a following sub-section of the dissertation.

Stress induced buckling

Stability problems such as buckling and bulging may be of significance where the wall of a steep dipping stope is separated by two families of discontinuities which dip vertically and strike parallel ($J1$) and perpendicular ($J2$) to the stope's long axis. The opening's wall and the discontinuities define the sides of a rock mass column with the width d_1 , thickness d_2 , and height L . The column is loaded in the vertical direction by the stress σ_z , while the horizontal stress σ_y is approximately equal to zero provided the stope wall is not supported.

Brittle buckling failure commences when a rock becomes cleaved in such a way as to separate portions close to a free face into long, continuous and narrow slabs, which will, due to an axial load, approach a region of buckling deformation (Fairhurst, 1966).

The mechanism of brittle buckling failure could be approximated as follows (Jeremic, 1987):

- Under the action of the major principal stresses a rock slab will split along the planes of schistosity and will form a rock “beam”, where its thickness is small compared to its length.
- These beams will eliminate the action of lateral stress and would act similar to a column with pinned ends (and are free to rotate).
- The slab will buckle due to axial loading in compression. As the axial compressive stress reaches the critical stress (σ_b), the rock slab will fail.

Rock slabbing by axial splitting and buckling is illustrated in Figure 2-6.

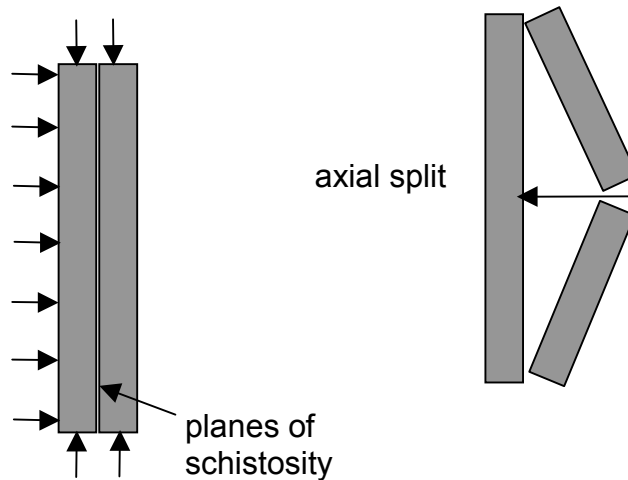

Figure 2-6 Rock slabbing by axial splitting and buckling

The following relationship for the buckling stress of the column is provided by stability theory assuming that the ends of the column are simply supported.

$$\sigma_b = \frac{\pi^2 \cdot E}{12 \left(\frac{L}{d_2}\right)^2} = \sigma_{z, max} \quad (2.29)$$

where:

σ_b = buckling stress

E = Young's modulus of intact rock (parallel to foliation)

d_2 = thickness of slabs

L = height of column

Once the buckling load has been exceeded ($\sigma_b > \sigma_z$), vertical slices of rock may burst away from the stope wall. Similar effects may also arise in the roof of excavations when the rock mass is loaded by large horizontal stresses.

Discussion – Stress induced buckling

- Brittle buckling failure of this type could be expected in steep orebodies in schistose host rock, or where geological structural defects delineate a column-type structure in the walls of the excavation.
- The aspect ratio of slabs are critical and could be improved by installing proper rock studs.
- The σ_z in the above equation can be obtained from finite element analysis and σ_b from Equation 2.29 or from Figure 2-7.

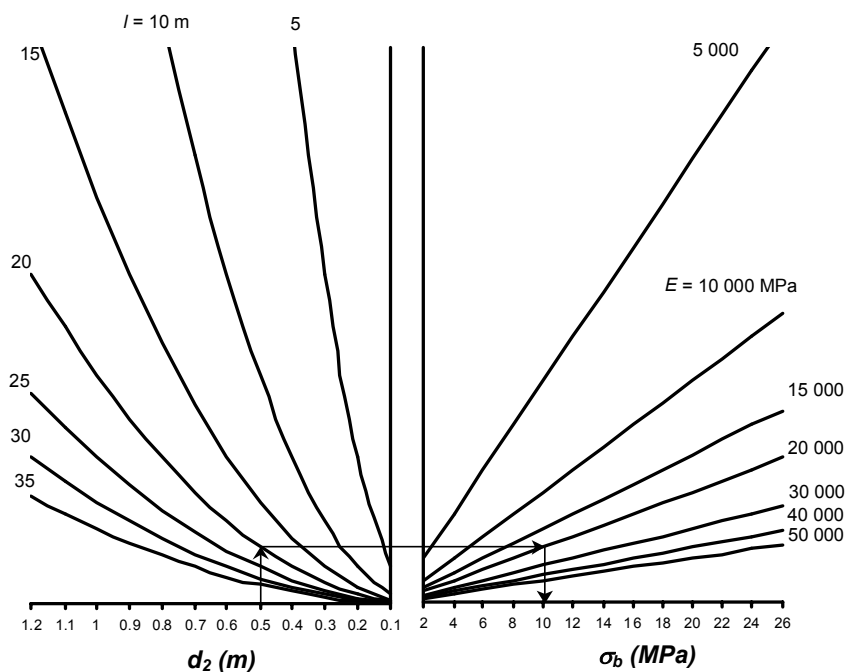

Figure 2-7 Relationship between column thickness, d_2 , column height, L , Young's Modulus, E , and

buckling stress, σ_b

Voussoir beam analysis

Evans (1941) introduced the Voussoir arch concept into rock engineering to explain the stability of a jointed rock beam. Although this concept initially created a great deal of controversy, it is now generally accepted. Brady and Brown (1985 and 1993) made a significant contribution in presenting the Voussoir arch theory in the form of a simplified design tool. Several authors have studied the Voussoir beam through numerical, experimental and analytical studies. The most recent important contribution to the theory is a paper by Diederichs and Kaiser (1999). In their paper, corrections and improvements to the iterative solution scheme presented by Brady and Brown (1985) were presented, and a more realistic yield threshold for snap-through failure was proposed to replace the ultimate rupture limit originally proposed by Evans (1941).

Diederichs and Kaiser (1999) provide a clear and concise explanation of the Voussoir beam theory and provides a good reference on the subject. The following paragraphs will briefly describe the most important points concerning the subject and the interested reader is referred to the original paper for more detail.

The most significant difference between the Voussoir beam theory and the elastic beam theory is the fact that the Voussoir beam material has no tensile strength in the horizontal direction. The moment that needs to be generated for stability, is generated by forming a compression arch inside the stratified rock as shown in Figure 2-8.

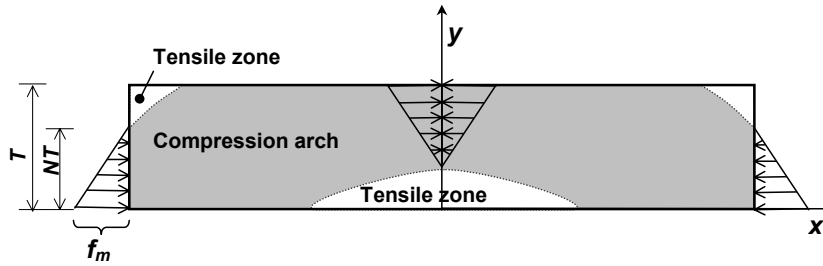

Figure 2-8 The compression arch forming inside the rock beam

A generalised version of the solution scheme proposed by Diederichs and Kaiser (1999) is shown in Figure 2-9 and Figure 2-10. The solution scheme systematically increases the value of N (the ratio of true to effective beam thickness) from 0 to 1, and calculates the values of f_m (the maximum horizontal stress in the beam), Z (the moment lever arm after deflection) and Z_o (the moment lever arm before deflection) corresponding to each value of N . The lowest and highest value for N that renders results, (N_{min} and N_{max}), is recorded for the calculation of the buckling limit. The smallest calculated value of f_m and the associated values of N , Z and Z_o are assumed to be the parameters for Voussoir beam formation at equilibrium state. These values are then used to check the stability of the beam against buckling, crushing and sliding. The midspan deflection can also be calculated.

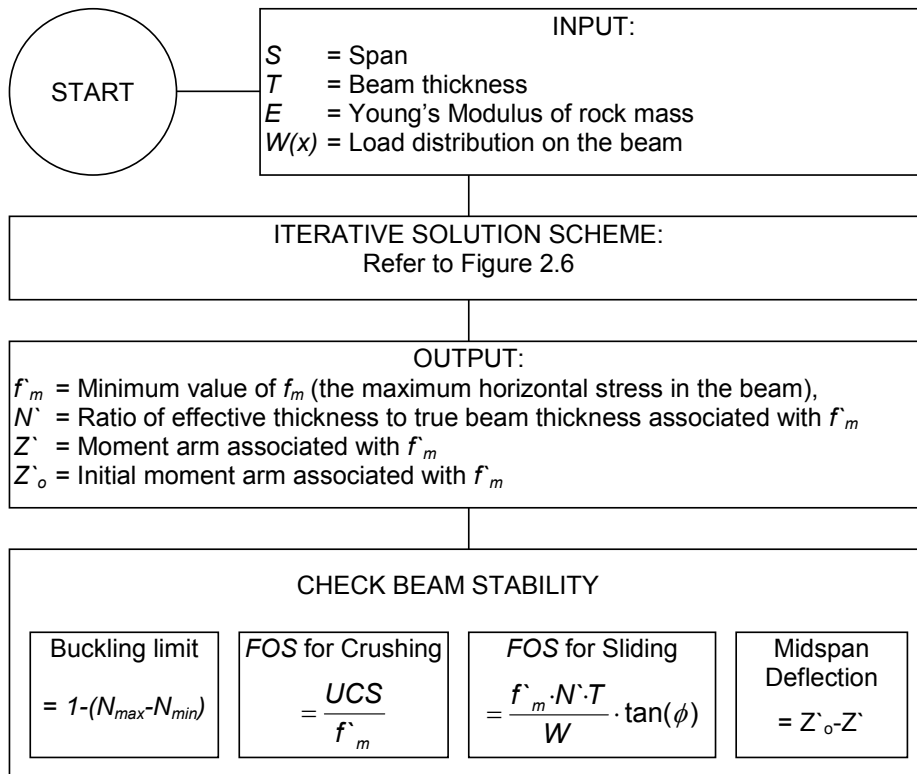

Figure 2-9 Flow chart for the determination of stability and deflection of a Voussoir beam

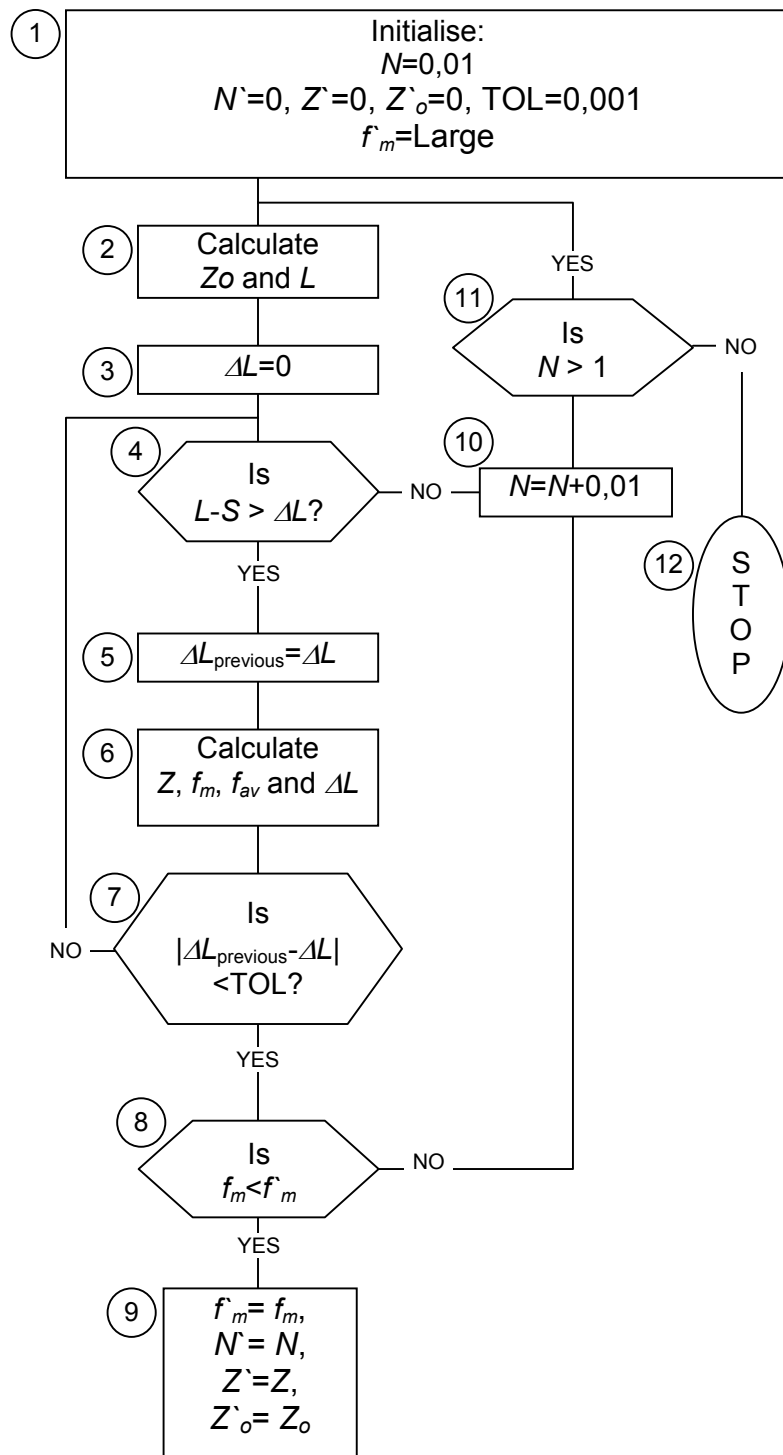

Figure 2-10 Flow chart for the iterative solution scheme proposed by Diederichs and Kaiser (1999)

In the iterative scheme shown in Figure 2-10, the first step after incrementing the value of N is to calculate the corresponding value of Z_o and L . Z_o can be calculated with the following equation derived from geometric considerations:

$$Z_o = T \cdot \left(1 - \frac{2}{3} \cdot N\right) \quad (2.30)$$

Evans (1941) assumes that the horizontal reaction force locus forms a parabola. This assumption has been accepted as reasonable by subsequent researchers since a parabolic reaction force locus can be proven valid for a uniformly loaded beam. Based on this assumption, Evans (1941) presented a simple equation which provides a very good approximation of the length of the horizontal reaction force locus:

$$L = S + \frac{8 \cdot Z_o^2}{3 \cdot S} \quad (2.31)$$

Calculation of Z is derived from the previous equation:

$$Z = \sqrt{\frac{3 \cdot S}{8} \cdot \left(\frac{8}{3 \cdot S} \cdot Z_o^2 - \Delta L\right)} = \sqrt{Z_o^2 - \frac{3 \cdot S}{8} \cdot \Delta L} \quad (2.32)$$

The value of f_m can be calculated with the following relationship derived from assuming moment equilibrium at the abutment:

$$f_m = \frac{2 \cdot M_w}{N \cdot T \cdot Z} \quad (2.33)$$

where:

M_w = The moment generated at the abutment

The total value of M_w can be calculated by summing the moments resulting from different portions of the total load. For example, the total moment generated on the abutment due to the loads on the beam illustrated in Figure 2-11, is given by the sum of the moment due the uniform loads w_1 and w_2 , and the triangular distribution with peak w_3 . These three components form the three factors in the following equation:

$$M_w = \frac{w_1 \cdot S^2}{8} + \frac{w_2 \cdot S^2}{8} + \frac{w_3 \cdot S^2}{12} \quad (2.34)$$

where:

S = Span of the beam

w_1, w_2, w_3 = Loads on the beam (force/unit length) depending on the nature of beam loading

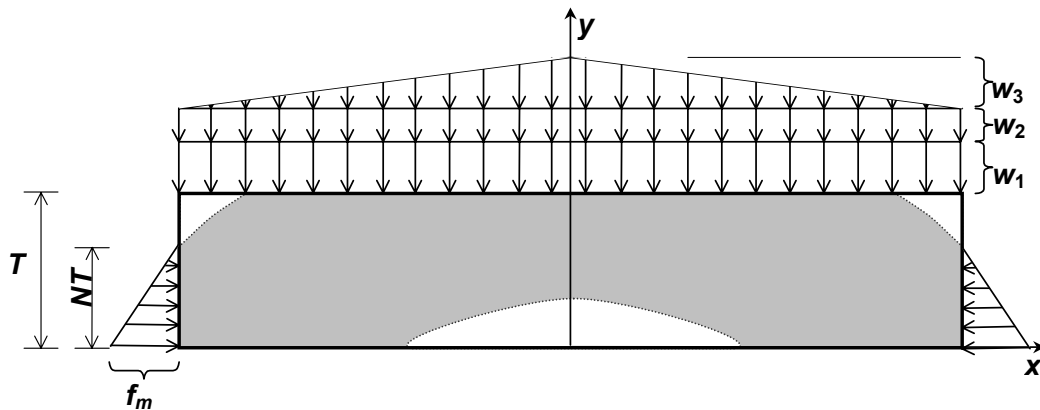

Figure 2-11 Illustration of the total loading on the beam

For a beam carrying its own weight only, w_2 and w_3 are zero and $w_1 = \gamma \cdot T$, resulting in the following simplified equation:

$$M_w = \frac{\gamma \cdot T \cdot S^2}{8} \quad (2.35)$$

where:

γ = The unit weight of the rock in the beam

The elastic shortening of the arch is assumed equal to the product of the mean value of the horizontal stress along the reaction force locus (Figure 2.8) and the modulus of elasticity parallel to the beam.

Diederichs and Kaiser (1999) pointed out that, in order to calculate the average horizontal stress along the reaction force locus, an assumption

has to be made on the internal stress distribution of the horizontal compressive stress within the beam. Evans (1941), Beer and Meek (1982), and Brady and Brown (1985) have assumed a quasi-linear variation of stress (Figure 2-12) resulting in the following equation for f_{av} :

$$f_{av} = \frac{f_m}{2} \cdot \left(\frac{2}{3} + \frac{N}{2} \right) \quad (2.36)$$

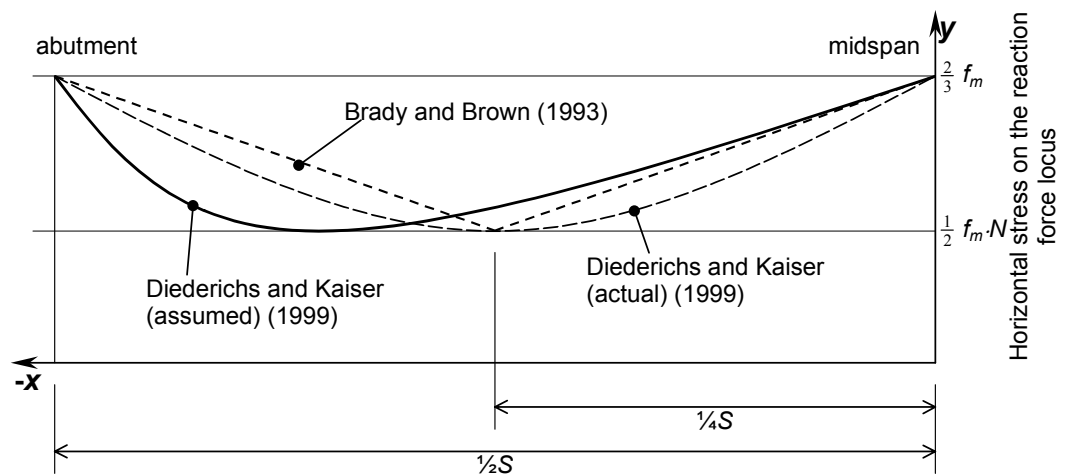

Figure 2-12 Comparison of the horizontal stress variation assumed by Brady and Brown (1985), and Diederichs and Kaiser (1999)

Diederichs and Kaiser (1999) reasoned that one can expect that at some point the whole beam will be under constant compression. This would be the point where the reaction force locus crosses the centre line of the beam. Their reasoning leads them to believe the variation of the horizontal stress along the reaction force locus to be the curved function shown in Figure 2-12. This is a reasonable assumption confirmed by numerical analyses (Diederichs and Kaiser, 1999).

Using the previously discussed equations in the iterative solution scheme proposed by Diederichs and Kaiser (1999) (Figure 2-10) the values of f_m , N , Z and Z_o for the stable Voussoir beam can be obtained. These values can subsequently be used to calculate the buckling limit, the factor of safety for crushing, the factor of safety for sliding, and the midspan deflection.

The buckling limit can be calculated as follows:

$$BL = 1 - (N_{max} - N_{min}) \quad (2.37)$$

where:

N_{max} and N_{min} = The maximum and minimum values of N for which a solution is possible.

The factor of safety against crushing can be calculated as:

$$FOS_{crushing} = \frac{UCS}{f_m} \quad (2.38)$$

where:

UCS = The uniaxial compressive strength of the rock material.

The factor of safety against sliding at the abutments can be written as:

$$FOS_{Sliding} = \frac{f_m \cdot N \cdot T}{W} \cdot \tan \phi \quad (2.39)$$

where:

W = The total load acting on the beam.

For the scenario illustrated in Figure 2-11, $w = (w_1 + w_2 + \frac{1}{2}w_3) \cdot S$.

The midspan deflection is given by:

$$\delta = Z_o - Z \quad (2.40)$$

Using these expressions, the stability of the Voussoir beam can be evaluated against sliding failure at the abutments, crushing of the rock at midspan and the abutments, and snapping through of the beam.

Discussion

The solution scheme employed by Brady and Brown (1985), and Diederichs and Kaiser (1999), assumes a constant arch thickness. The influence of this assumption on the accuracy of the solution is unknown and needs further investigation.

The Voussoir beam analysis described in the literature does not include analysis of shear movement along joints and parting planes and design of tendons to prevent such movement.

The elastic shortening of the arch is assumed to be equal to the product of the mean value of the horizontal stress along the reaction force locus (Figure 2-12) and the modulus of elasticity parallel to the beam. The validity of this assumption has not been proven or challenged in literature and needs further attention.

2.2.3 Literature review and evaluation of keyblock stability analysis

In shallow underground excavations in hard rock, failure is frequently controlled by the presence of discontinuities such as faults, shear zones, bedding planes and joints. The intersection of these structural features can release blocks or wedges which can fall or slide from the surface of the excavation. Failure of the intact rock is seldom a problem in these cases where deformation and failure are caused by sliding along individual discontinuity surfaces or along lines of intersection of surfaces. Separation of planes and rotation of blocks and wedges can also play a role in the deformation and failure process.

Analysis of the stability of these excavations depends on:

- Correct interpretation of the structural geology;
- Identification of potential unstable blocks and wedges;
- Analysis of the stability of the blocks and wedges which can be released by the creation of the excavation;
- Analysis of the reinforcing forces required to stabilise these blocks and wedges.

Limit equilibrium calculations based upon the volume of potential wedges or blocks can be used on-site to decide on the number, length and capacity of the rockbolts required.

Gravity driven falls of ground (FOG's) account for a large proportion of all rock fall accidents in shallow underground mines (Joughin *et al* , 1998). These FOG's originate from unstable blocks of rock or keyblocks bounded by natural joints or mining induced fractures. These blocks fail if their weight exceeds the support capacity or if they are located between support units. In principal, support effectiveness is determined by the number of keyblocks that are held in place by the support. In theory it is only necessary to support keyblocks, then the remainder of the rock mass will be unable to fail.

Exposed stope hangingwalls which are intersected by numerous joints or fractures and which contribute to the formation of unstable keyblocks should be stabilised by supporting as many keyblocks as possible. It is impractical to attempt to map each joint or fracture and carry out a stability analysis to identify potential keyblocks. A design tool is therefore required which will allow the evaluation of the type and frequency of keyblocks that may be formed and the effect of different support systems on the probability of failure of the keyblocks.

In a conventional deterministic keyblock analysis as described by Goodman and Shi (1985), the natural scatter that is observed in rock masses is ignored if mean values are used. The effect of joint continuity is

also ignored if the joint and excavation planes are considered to be of infinite extent. This type of modelling can be restrictive and tends to generate a worst-case type of analysis with no indication of the expected block geometry or determination of the frequency or probability of occurrence.

In an attempt to overcome these problems, several different types of probabilistic keyblock models have been developed. One such method, JBlock (Esterhuizen, 1996) has been evaluated in detail by Daehnke *et al* (1998) and will not be repeated here.

The following conclusions can be made regarding the program JBlock:

- Keyblock stability can be evaluated best by using a probabilistic design approach.
- The JBlock program is easy to operate and runs on a standard personal computer.
- The program can be used to carry out:
 - single block analysis (evaluate the probability of failure of blocks of a known size);
 - multiple block analysis. (evaluate blocks which are randomly created according to the natural joints and stress fractures.
- The program tests the sensitivity of keyblock failure to support spacings.
- The program evaluates the effectiveness of a new support system in preventing falls of ground of a particular size.
- The effect of headboards on supports is evaluated.
- The program finds the best orientation of the stope face relative to keyblocks in the hangingwall.
- The output of the program provides insight into interaction of support and keyblocks.
- The effect of changing support types, support layouts and excavation orientation may be evaluated.
- The potential for failure in varying geological conditions may be evaluated.

- The program complements beam stability analysis to determine stable spans for jointed beams.
- The program shows that, as the size of keyblocks increases, the probability of falling out between supports decrease but the probability of the weight of the block causing supports to fail increases. Larger blocks, however, might become self-supporting through other mechanisms such as the Voussoir beam concept.
- The program identifies hazardous areas.
- The effect of different support patterns is evaluated.
- The program provides the necessary insight into the complex interaction between stope support units and the fractured hangingwall. The method takes account of site specific geology in support design. Application of the program will result in improved support design and hence improved safety in stoping excavations (Daehnke *et al* , 1998).
- JBlock is probably the best commercial analysis tool available to assess the probability of keyblock failure in the hangingwall of stopes. However, the acceptability or not of calculated probabilities should be assessed in terms of the associated risks.

2.3 Literature review and evaluation of observational design methods

Observational design methods rely on the monitoring of ground movement during mining to detect measurable instability. If necessary, the original design is then adjusted to optimise panel stability. The observational approach would require a large database and would have to be implemented in the initial stages of stoping in order to achieve some reliable measurement of stability.

Peck (1969) formalised the observational design method. In this approach, further data are collected during excavation, and the performance of the excavation is monitored. The new data is then fed back into the original models and re-analysed. The designs or conclusions are then revised as appropriate. Therefore, adding further data during the monitoring of stope

performance is an essential component of the on-going rock mass characterisation process.

In some cases, a whole philosophy has been attached to an observational method making it distinct from other approaches. One such case, the New Austrian Tunnelling Method (NATM), has received considerable attention in the field of tunnelling. The NATM involves continuous monitoring of rock movement and the revision of support to obtain the most stable and economic lining.

Of the various monitoring techniques available for stoping, displacement measurements have proven to be most useful. The main reasons are:

- displacement is a quantity that can be measured directly;
- displacement can be monitored continuously and relatively easily;
- displacement measurements provide information on overall movement of the rock mass within the measured distance and thus do not display a large variability.

Data obtained from the monitoring of stope panel stability and displacement is important in terms of measuring the success, or not, of a specific design. This data, however, will be meaningless if not fed back to the rock mass characterisation phase of the design process. Also, appropriate criteria for the evaluation of monitored data should be used.

2.4 Literature review and evaluation of engineering design methodologies

According to the Engineers' Council for Professional Development (*ECPD*) (Wilde, 1975 and 1978), engineering design can be defined as follows: "The process of devising a system, components, or process to meet desired needs. It is a decision-making process (often iterative), in which the basic sciences, mathematics, and engineering sciences are applied to convert resources optimally to meet a stated objective. Among the

fundamental elements of the design process are the establishment of objectives and criteria, analysis, synthesis, construction, testing and evaluation. Central to the process are the essential and complementary roles of analysis and synthesis. In addition, sociological, economical, aesthetical, legal and ethical considerations need be included in the design process.”

Bieniawski (1984) defined engineering design as that socio-economic activity by which scientific, engineering, and behavioural principles, together with technical information and experience, are applied with skill, imagination, and judgement in the creation of functional economical, aesthetical pleasing, and environmentally acceptable devices, processes, or systems for the benefit of the society. The design process embraces all those activities and events that occur between recognition of a social need or opportunity and the detailed specification of acceptable solution. The designer’s responsibility continues during the manufacture or construction of the project and even beyond it.

Hill (1983) gave the following description of the engineering design process: “The design process is not a formula or even a prescription that will guarantee a successful design. It should be considered rather as a sequence of events within which a design can be caused to unfold logically. It consists of a series of steps that can serve as a useful reference of where we are, where we ought to be, and the next step in executing a successful design. The process can serve as an excellent work plan in the planning of a design program.”

Bieniawski (1984) continued by distinguishing between the following eleven stages in the design process:

- Recognition of a need or a problem.
- Statement of the problem.
- Collection of information.

- Concept formulation in accordance with design criteria: search for a method, theory, model, or hypothesis.
- Analysis of solution components.
- Synthesis to create a detailed solution.
- Evaluation and testing of the solution.
- Optimisation.
- Recommendation.
- Communication.
- Implementation.

Stacey and Page (1986) suggested that the following approach to underground excavation design be followed:

- Determine shape and size of excavation based on the purpose of the excavation. In the case of stoping, the shape and size will be determined by the orebody geometry and the chosen mining method.
- Consider an “ideal” excavation which best satisfies the purpose.
- Consider the practicality of this “ideal” opening in relation to the properties of the rock mass in which it will be located.
- Ascertain the stability of the “ideal” excavation by:
 - determining the mode of any identified instability;
 - test for stress induced failure around opening;
 - test for instability of large blocks;
 - classify the rock mass and test for rock mass instability;
- If necessary, optimise “ideal” excavation in terms of size, shape, orientation or location in order to overcome instability. (Loop back to (3) if any geometrical changes are made).
- If modified excavation is still unstable, determine support required to overcome instability. (Appropriate support will depend on the risk associated with an excavation.)

Brown (1985) listed the following components of a generalised programme for underground excavation design:

- Site characterisation:
 - Definition of geomechanical properties.

- Geotechnical model formulation:
 - Conceptualisation of site characterisation data.

- Design analysis:
 - Selection and application of mathematical and computational schemes for study of trial designs.

- Rock mass performance monitoring:
 - Measurement of the performance of the host rock mass during and after excavation

- Retrospective analysis:
 - Quantification of *in situ* rock mass properties and identification of dominant modes of rock mass response.

3 Data collection from selected mines

3.1 General data collection

Mines with different orebody geometries (tabular, massive and pipe) were identified and visited during the second part of this study. These mines are:

- Eastern Chrome Mines;
- Western Chrome Mines;
- Dilokong Mine;
- Finsch Mine;
- Rosh Pinah Mine;
- Premier Mine;
- Black Mountain Mine;
- Thabazimbi Mine;
- Wessels Manganese Mine.

The knowledge gained during the literature survey was used to compile a questionnaire, which was sent to the mines listed above. Unfortunately, the data obtained from the mines is generally limited and not suitable for statistical analyses. Nevertheless, the information obtained from the questionnaire assisted in forming certain perceptions regarding the design of stable stope spans on different mines and listing factors governing the stability of stope panels.

The aim of the mine visits was to visit stable and unstable stopes under different geotechnical conditions and to assess the influence of factors governing the stability of stope panels. The opinions of mine rock mechanics personnel on the design of stope panels under different geotechnical conditions were also obtained during the mine visits.

The factors listed below was considered pertinent to the design of stable stope panels and formed part of the questionnaire prepared for the survey. (See Appendix B for an example). The comments listed are based on the information obtained from the completed questionnaires and from discussions with rock mechanics personnel.

- Depth of mining:
- The depth of mining on the mines visited varies between 30 m and 600 m below surface.
- FOG accident statistics:
- Compared to the rest of the mining industry, relatively few FOG accidents have occurred on the mines visited over the last few years. FOG incidents, however, occur on all mines. These incidents are often not recorded, investigated or back-analysed.
- Major causes of fall of ground (FOG) accidents/incidents:
- In most cases, FOG accidents/incidents are caused by failure along geological structures. Examples of these are:
 - shear zones;
 - folding;
 - weathered zones;
 - faults;
 - major joints;
 - schist bands;
 - geological contacts;
 - intrusions.
- Bad barring practices was also identified as a potential cause for FOG accidents.
- Typical dimensions of FOG's:
- In some cases, FOG incidents measuring tens of metres in width and length have been recorded. Most FOG's, however, are less than 2,0 m thick.
- Geotechnical information:
- Geotechnical information on most mines is limited and cannot be used for any stope panel design.
- General geology, including description of major geological structures:

- The general geology of the mines is well documented. Local changes in geology, however, often result in difficult mining conditions which have not been predicted due to a lack of knowledge about the local geology.
- Boundary conditions:
 - Most mines do not consider boundary conditions such as *in situ* stress conditions and proximity to surface during stope panel design.
- Rock mass classification data:
 - Only three mines use rock mass classifications data on an ongoing basis. In one case, geotechnical plans with ratings compiled from underground mapping were used to define geotechnical areas.
- Pro-active identification of prominent structural features:
 - Two mines use underground geotechnical drilling to identify prominent geological features pro-actively or to define the position of known contacts more accurately.
- Mine standards for stope panel widths:
 - Most mine standards are based on local experience and equipment requirements. In a few cases, mine standards are based on stability analyses using Laubscher's stability index method or numerical modelling.
- Description of design methodology for stable stope panels:
 - Most mines rely on local experience to determine stable stope panels. In most cases, panel widths are also dictated by equipment requirements. Laubscher's stability index method and numerical modelling are being used by a few mines to determine stable stope panels.
- Mine standard for in-stope support:
 - Most mine support standards are based on the tributary area theory and local experience.
- Description of support design methodology.
 - Most support designs are based on the suspension approach.

The adherence to certain rock engineering practices related to the design of stable stope spans on the mines visited is listed in Table 3-1 below.

Table 3-1 Rock engineering practices followed by mines to ensure stability of stope spans

Rock engineering practices	Mine visited								
	1	2	3	4	5	6	7	8	9
FOGs associated with geological structures	Y	Y	Y	N	Y	N	Y	Y	Y
FOG statistics complete and analysed	N	N	N	Y	Y	Y	N	Y	N
FOG incidents investigated, recorded, analysed	N	N	N	Y	N	Y	N	N	N
Adequate rock mass characterisation and database	N	N	N	Y	Y	Y	N	Y	N
Geology well documented	Y	Y	Y	Y	Y	Y	Y	Y	Y
Boundary conditions considered in design	N	N	N	Y	N	Y	N	N	N
Rock mass classification carried out	N	N	N	Y	Y	Y	N	N	N
Stability analyses carried out	N	N	N	Y	N	Y	N	N	N
Typical failure mode:									
- beam	Y	Y	Y					Y	Y
- wedge	Y	Y	Y	Y	Y	Y	Y	Y	Y
- other	Y	Y	Y	Y		Y			
Stope span design based on appropriate failure mode	N	N	N	N	N	N	N	N	Y
Stable stope spans based on :									
- experience	Y	Y	Y	Y	Y	Y	Y	Y	Y
- equipment requirements	Y	Y	Y	Y	Y	Y	Y	Y	Y
- proper engineering design	N	N	N	N	N	N	N	N	N
Formal pillar design	Y	Y	Y	Y	Y	Y	Y	Y	Y
FOG hazard assessments carried out	Y	Y	Y	Y	Y	Y	Y	Y	Y
FOG risk assessments carried out	N	N	N	Y	N	Y	N	N	N
Design for stope spans and support reviewed by external party	N	N	N	N	N	N	N	N	N
Monitoring carried out	N	N	N	Y	N	Y	N	Y	N

The following conclusions can be drawn from the information gathered:

- Not one mine is using a proper engineering approach to stope panel and support design.
- Although most FOG incidents/accidents are associated by failure along geological structures, most mines do not use any design methodology based on structural analysis. In a few cases, complicated numerical analysis programs are used on an *ad hoc* basis to assess structurally controlled panel stability.

- In most cases, panel lengths are based on local experience and equipment requirements.
- Stope pillars are normally designed conservatively and the probability of regional instability, involving several stope panels, is unlikely.
- Valuable information regarding panel stability are often lost because FOG incidents are not investigated, recorded or back-analysed.
- Beam stability analyses are applicable to several mines and should be considered as one of the potential failure modes.
- There is a need for a systematic engineering approach to the design of stable stope panels.

3.2 Rock mass characterisation on specific mines

A review of research carried out by Joughin *et al* (1998) showed that mines with tabular orebodies, in particular chrome mines, have a relatively high risk of rock fall accidents. It was therefore decided to pay special attention to the stability of panels found in chrome mines.

Underground mapping was carried out at selected sites found on three chrome mines, Mines A, B and C. Selected localities, representative of the variation in rock mass conditions observed at the mines, were mapped in detail. The aim of the underground mapping was to back-analyse cases of stable and unstable stope panels using rock mass classification techniques.

A more detailed study, including geotechnical mapping, borehole logging, statistical analysis of geotechnical parameters and an estimation of material properties for numerical analysis purposes was carried out on Mine A. Underground mapping at Mine A was carried out in two sections, Section D and Section S.

At the time of the site visits, all the underground sections used room and pillar mining with conventional scraper cleaning. Most areas have been

mined using breast panels with lengths of between 20 m and 30 m. Non-yielding pillars have been used as the main form of stope support.

Timber sticks and *ad hoc* in-stope pillars have been used as the basic support elements for most stope panels. Other panel support such as pre-stressed elongates and rockbolts have been introduced recently.

At Mine A, a pyroxenite parting of between 0,8 m and 0,9 m thick separates the LG6 chromitite seam from the LG6A seam above. The pyroxenite above the LG6A is more than 10 m thick. The depth of existing underground workings varies between 30 m and 500 m below surface.

3.2.1 Site characterisation

Geotechnical mapping of underground workings

Geotechnical mapping was conducted in areas of the mines which were stable, in areas where falls of ground had occurred and in areas where there were unfavourable rock conditions, and thus the potential for falls of ground to occur. Failure and instability that had occurred in these mines were generally in the form of wedges, domes, blocks and plates (beams) associated with unfavourably oriented joints, faults, fractured zones or excessive panel spans. Obviously, the support used at the time of the FOG had been inadequate to prevent the FOG incident from occurring.

Data obtained in the mapping exercise were subsequently used to analyse the differences in rock mass conditions in areas of different stability. This data could be used to assess the conditions under which rock will stand up, and thus aid in assessing safe stoping spans.

At each of the selected localities relevant geotechnical parameters that influence the performance of a rock mass were measured and recorded. These included inherent properties of the rock mass as well as external factors. Table 3-2 lists the parameters that were recorded.

Table 3-2 Summary of measured geotechnical and mining parameters

Rock Mass Parameters Measured	Mining Parameters Observed or Measured
Intact rock strength (<i>IRS</i>)	Quality of blasting
Discontinuity – spacing (<i>FF</i>)	Mining induced stresses
Discontinuity – condition (<i>JC</i>)	Orientation of excavation relative to joints
- joint roughness (small + large scale)	
- joint infill type	
- joint infill thickness	
Discontinuity - continuity (dip and strike)	
Orientation of discontinuities - relative to excavation	
Ground water	
Weatherability of the intact rock	

Mapping was carried out using the method suggested by Laubscher (1990). This method was chosen as it includes many of the variables that influence stability. Intact rock strength (*IRS*), rock quality designation (*RQD*), fracture frequency (*FF*), joint condition (*JC*) give a rock mass rating which is then adjusted for weathering, orientation, stress and blasting to give the mining rock mass rating (*MRMR*). The rating obtained classified the rock as very poor to very good.

The data was also collected in such a way that it could be used in other rock mass classification systems such as Bieniawski's *RMR* system (1989) and the *Q* system of Barton *et al* (1974). The sensitivity of each system to changes in the rock mass condition (as noted on the mine) could thus be assessed.

Particular care was taken to ensure that all of the rock mass parameters that were necessary to classify the rock mass using the frequently used systems were measured directly. The *RQD* is one of the most frequently used parameters in rock mass classifications systems, but it cannot be

measured directly from mapping. Estimates of *RQD* were made for each locality and the number corroborated with a calculated *RQD* using the Palmström (1982) equation.

The two mapping methods used were window mapping and line mapping. In window mapping, a representative area between 2 m x 2 m and 5 m x 5 m is selected and representative joint orientations and spacings are recorded. In line mapping, a tape is laid out and every joint crossing the line is measured.

Line mapping

In a line survey, a measuring tape is laid out and every joint along the survey line is mapped. The distance (along the tape), dip and dip direction and joint condition (alteration, infill and small scale roughness) are noted. If a joint is present sub-parallel to the line, it is measured and the distance from the line is recorded. For the purpose of this study, if a cluster of joints was encountered a representative reading was taken and the joint spacing noted.

Where possible, two line surveys were carried out at right angles to intersect major joints both parallel and perpendicular to the stope. In open stopes, line surveys were carried out at an orientation to intersect both major joint sets. It has been suggested that a third line survey be carried out vertically along a pillar, but it was found that the horizontal joints were widely spaced, and often only one was present in the height of the pillar.

The advantage of line mapping is that each joint is measured individually, and contributes to a statistical database that is used to provide essential information. Also, since all random joints are measured, their influence on joint stability may be assessed.

Window mapping

Window mapping is a tool that enables the rock mass condition to be quantitatively assessed in a short time. A three-dimensional zone or “window” that is representative of a particular geotechnical zone is identified, and then described in terms of the parameters listed in Table 3-2. Joint sets, rather than individual joints, are identified and the average value of the parameters described.

Joint orientations

Three main joint sets were identified during underground mapping in Sections D and S. The joint set striking parallel to the strike of the orebody was named the J1 joint set. The set striking parallel to the dip of the orebody was named the J2 joint set. Flat lying joints, which were often sub-parallel to the orebody, were named the J3 joint set.

Figure 3-1 is a graphical presentation in the form of stereonet of all the joint orientation data collected from Sections D and S. The average dip and dip directions for the major joint sets in Sections D and S are summarised

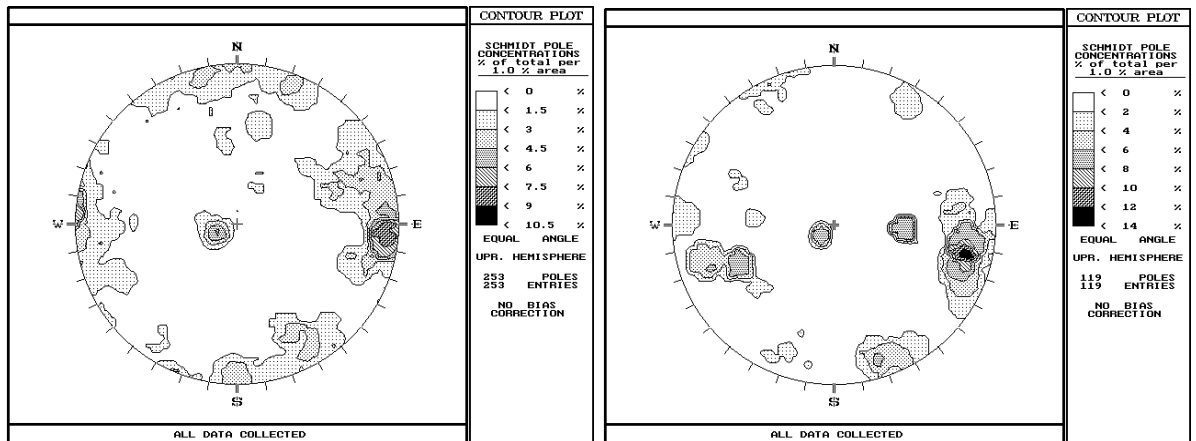

in Table 3-3.

Figure 3-1 Contour plots of joint orientation data from Sections D and S

Table 3-3 Summary of dip and dip directions of major joint sets in Sections D and S

Location	J1	Range	J2	Range	J3	Range
Section D	84/094 89/282	74/083 - 89/104 84/269 - 89/104	80/145 87/346	70/131- 88/163 80/337 - 89/173	-	-
Section S	79/103 68/249	63/086 - 89/121 53/228 - 87/263	82/160	71/148 - 89/173	12/23 0	03/180- 22/299

From Figure 3-1 and Table 3-3, it can be seen that the range in dip and dip direction readings from the two mining sections are similar.

Geotechnical areas

Areas or zones of different geotechnical conditions present in both sections could be classified into three broad groups based on their jointing. These areas are: competent zones, fractured zones and domed areas.

- **Competent zones** are zones where the joint spacing in the hangingwall is wide (Deere, 1968) and the joint condition is competent. Falls of ground in competent zones are rare.
- **Fractured zones** are areas of closely spaced (Deere, 1967) joints and may be associated with faults or dykes. The orientation of the fracture zones is often parallel to the *J1* joint set, but a few zones were noted oriented parallel to the *J2* joint set. These zones are usually of limited width of about 2 m to 5 m. They are often continuous, with trace lengths of greater than 20 m. The joints are slickensided planar to undulating. The majority of joints within the fracture zone do not contain any infill, but a few have up to 2 mm of soft sheared material. Within the fracture zone, conjugate joint sets are found which often form wedges which may fall out.

- **Domes** are formed by continuous, flat lying, curved joints that are often slickensided and contain up to 5 mm of soft sheared infill. The “onion skin” structure seen may be caused by parallel doming joints approximately 0.5 m apart. Release surfaces are provided by both *J1* and *J2* joints, allowing large falls of ground to occur.

Blast damage

Underground observations revealed that the outer 80 mm of pillar sidewalls is being damaged by blasting. In one case it was noted that pillar overbreak reduced pillar dimensions by up to 250 mm. In Section D, it was noted that minor wedges that had fallen could be ascribed for bad drilling. Hangingwall sockets in the proximity of some small domes also indicated the influence of drilling and blasting on falls of ground that had occurred. This emphasises the effect that poor drilling and blasting can have on stope stability.

Mapping results

Underground mapping at Mines A, B and C

The mapping results for Mines A, B and C are summarised in Appendix C.

Underground mapping in Section D of Mine A

Window mapping were carried out on pillars and the hangingwall in areas of competent ground, fracture zones and domes of Section D. In order to pick up all joint sets, scanline surveys were carried out along the strike and dip of the orebody. Details of these surveys are depicted in Figure 3-2 to Figure 3-7.

It was found that joints in the **competent zones** are spaced about 1 m apart in the hangingwall and 0,3 m in the pillars. *MRMR* values for the hangingwall ranged from 60-69, giving *DRMS* values ranging from 78 MPa -94 MPa.

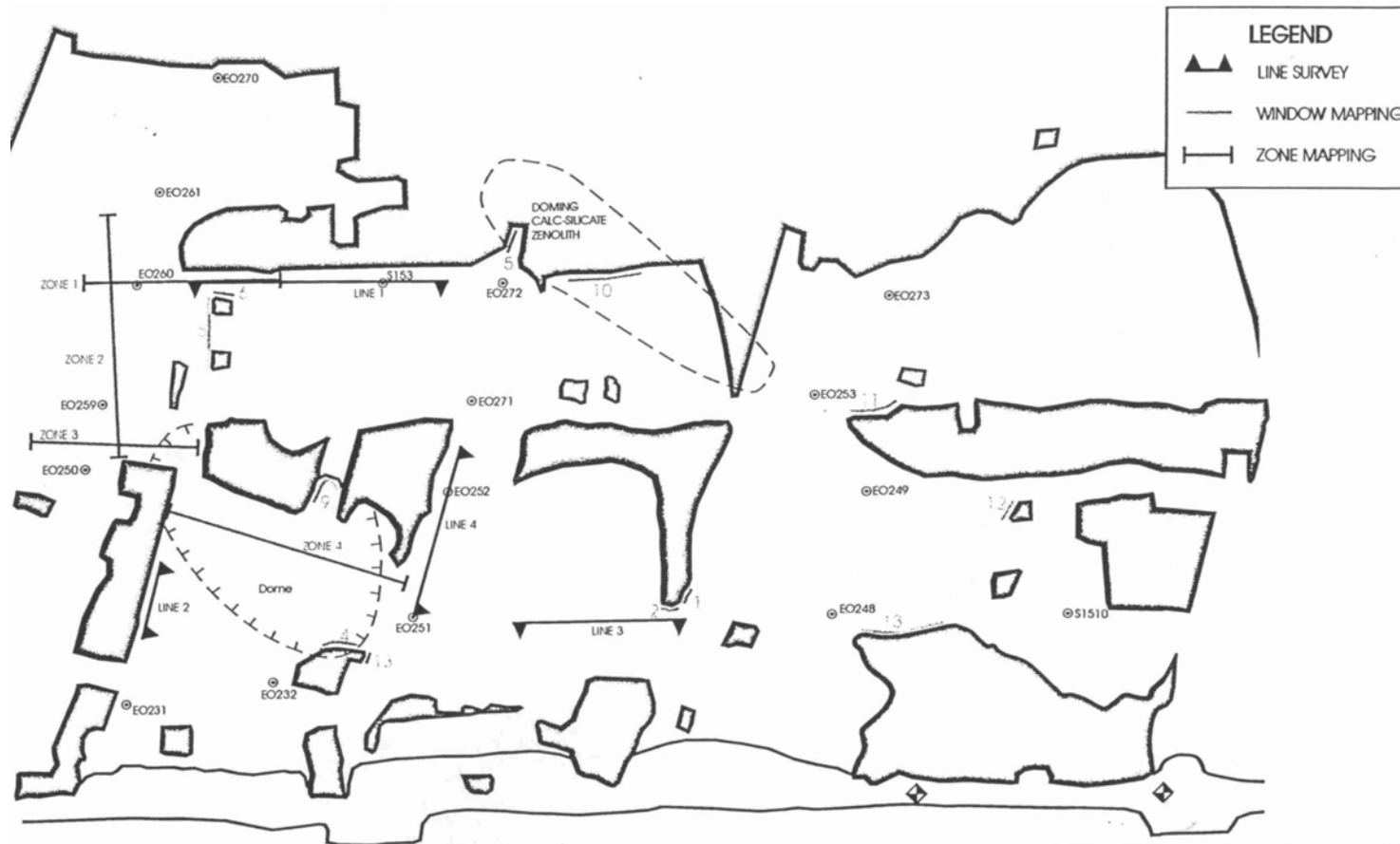

Figure 3-2 Plan of Section D 27-7, showing mapping locations

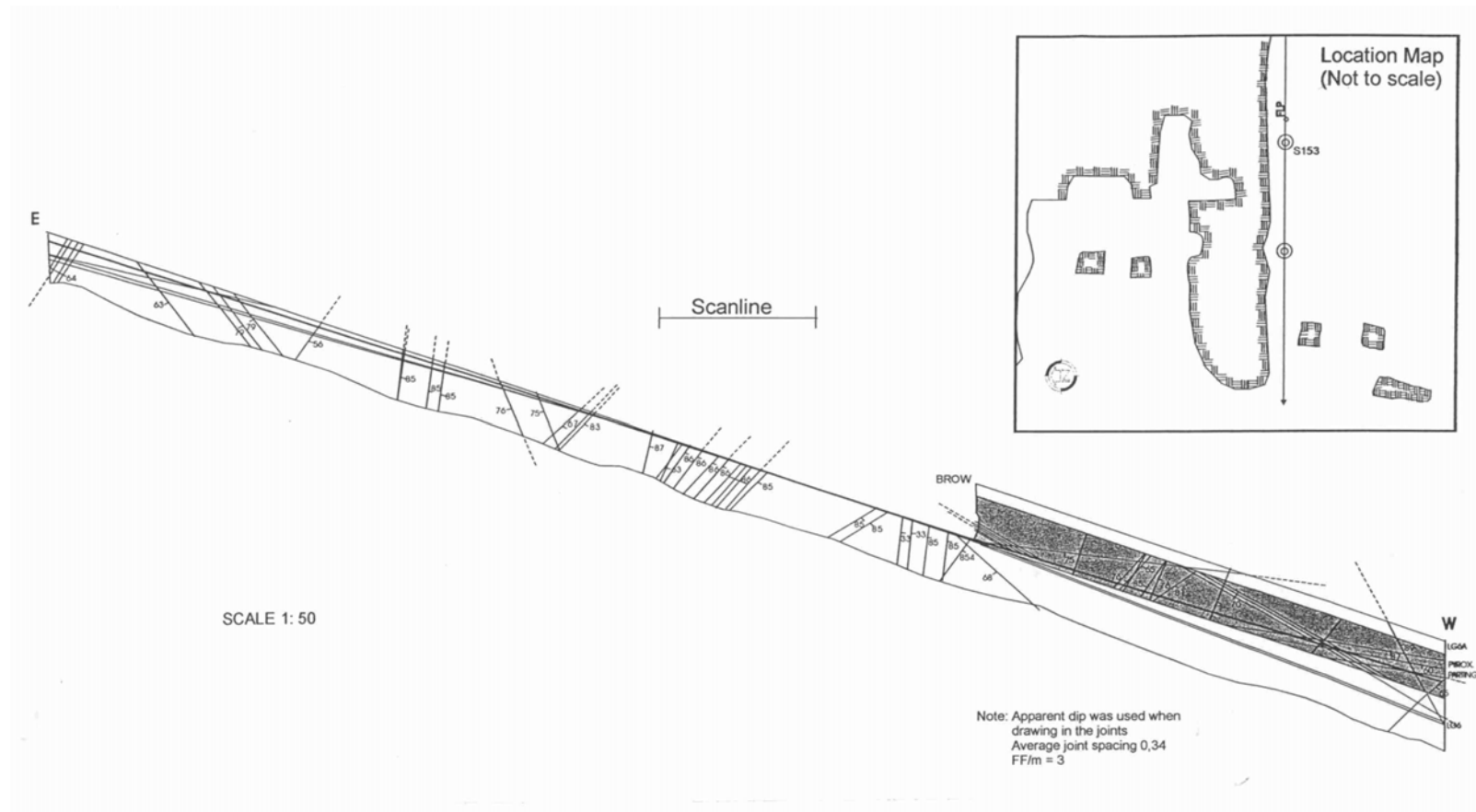

Figure 3-3 Section D 27-7: Section through pillar - scanline 1

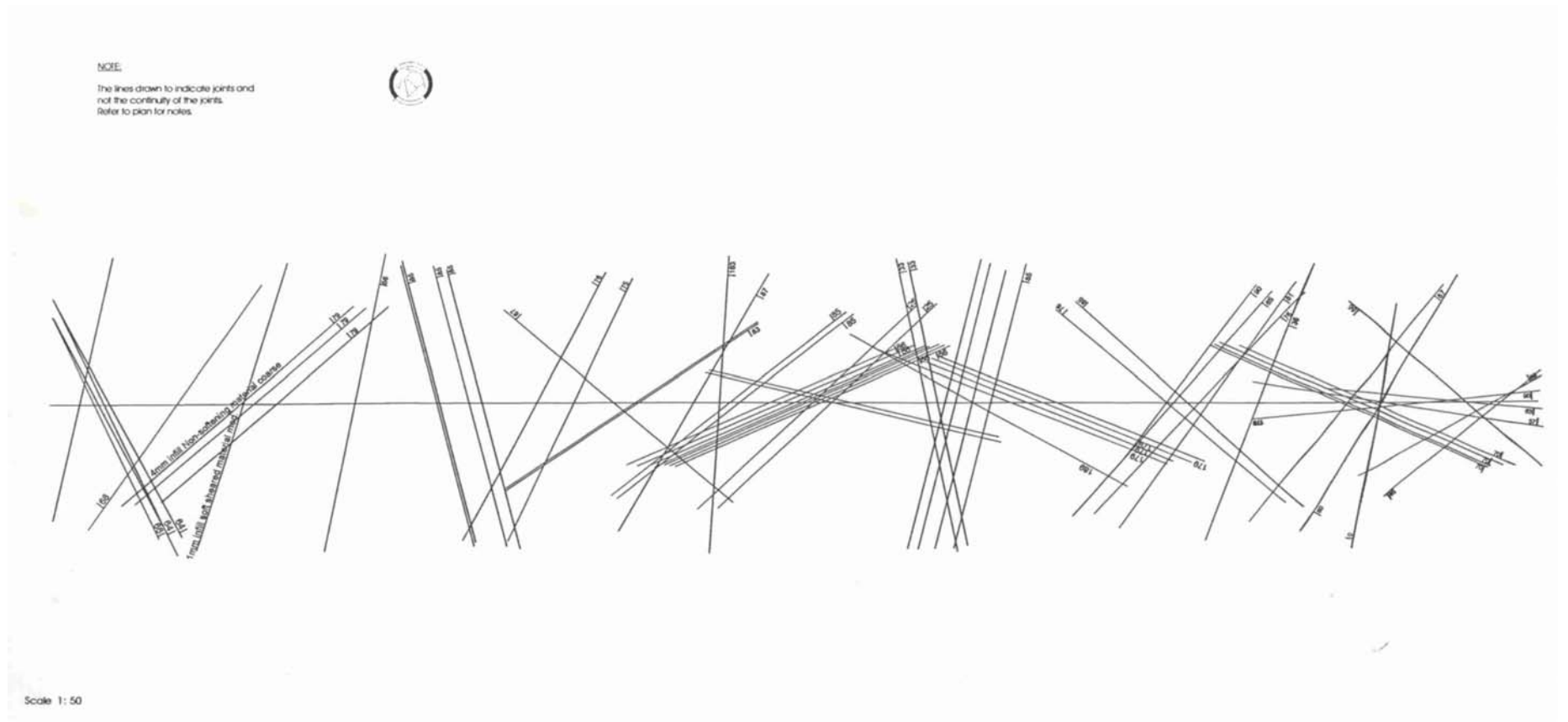

Figure 3-4 Section D 27-7: Plan view of scanline 1

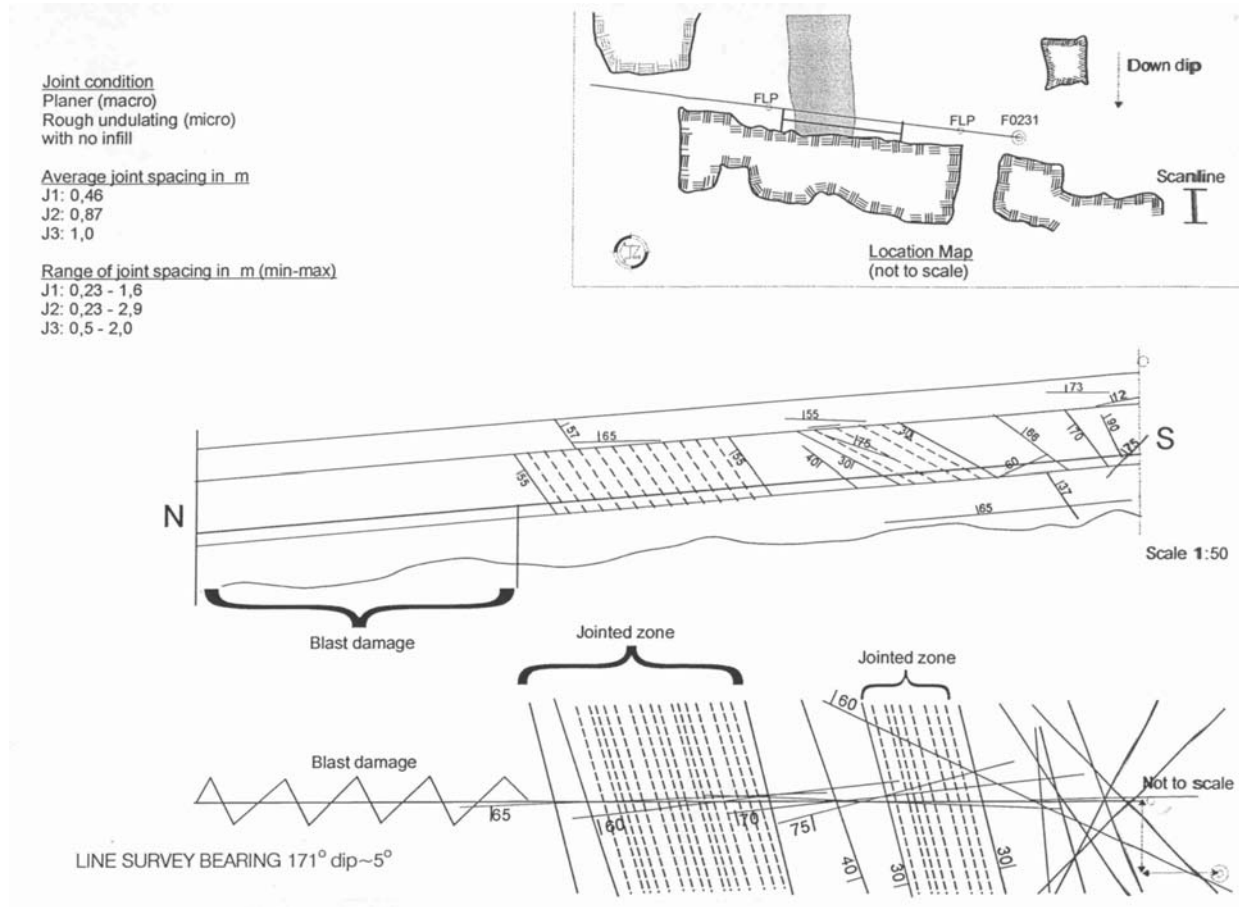

Figure 3-5 Section D 27-7: Plan view and section of pillar scanline 2 (below large dome)

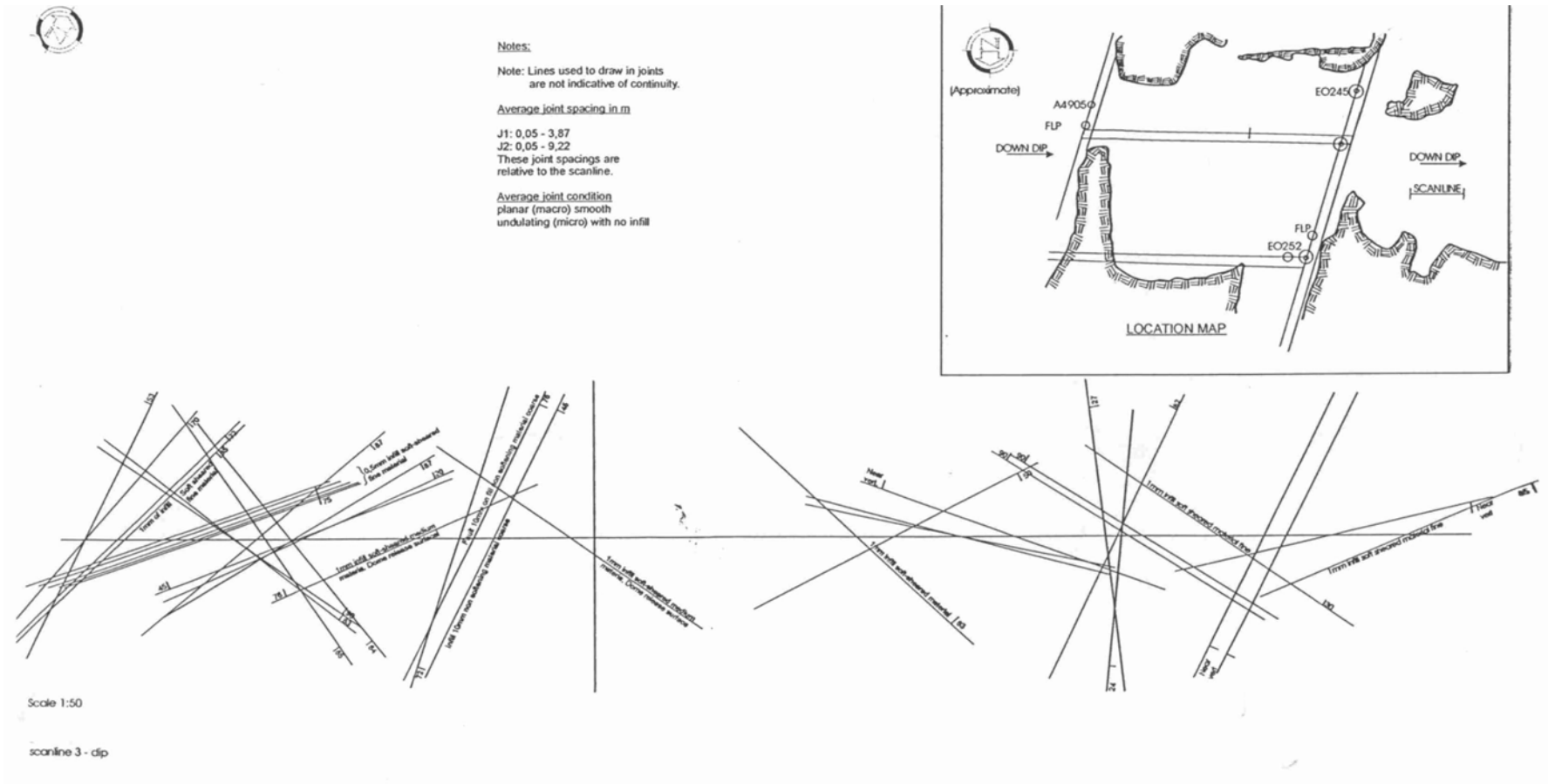

Figure 3-6 Section D 27-7: Plan view of hangingwall scanline 3

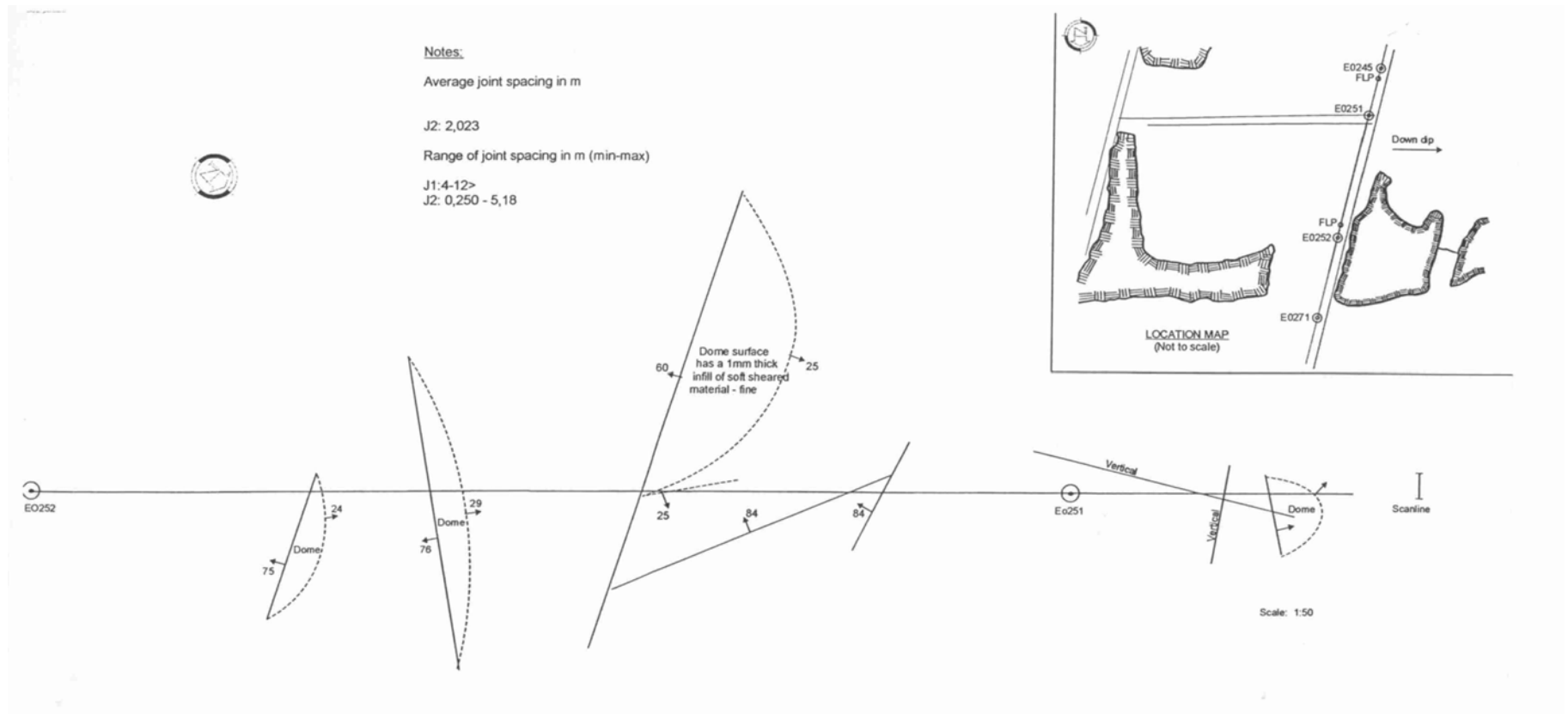

Figure 3-7 Section D 27-7: Plan view of hangingwall scanline 4

Fracture zones were noted every 10 to 20 m, and at least one fracture zone was seen in each of the four panels where mapping was undertaken.

The closer joint spacing in the fracture zones gave *MRMR* values ranging from 44-55 for the hangingwall. The corresponding ranges of *DRMS* values for the hangingwall are 49-72 MPa respectively.

Both large and small **domes** were seen in Section D. Doming joints are widely spaced, (greater than 10 m), but are continuous and contain weak infill that makes the joints weak and prone to falls of ground. Dome distribution seemed to regionally random, but locally clustered. The largest dome mapped covers an area greater than a panel, but most are less than ten metres wide. In the upper panels of Section D, a series of small domes (approximately 1 m in diameter) were observed. The majority of the large domes seen are oriented with their long axis sub-parallel to the dip of the orebody, with *J1* joints forming the release surfaces. These domes have undulating, slickensided curved surfaces with soft sheared infill. Smaller domes are oriented both along dip and strike of the orebody with both *J1* and *J2* joints forming release surfaces. The small domes are curved, rough undulating and generally contain no infill.

Table 3-4 summarises the average *MRMR* and *DRMS* values obtained from hangingwall mapping.

Table 3-4 Summary of average RMR, MRMR, RMS and DRMS for the hangingwall in Section D

Mapping Technique	<i>RMR</i>	<i>MRMR</i>	Class	<i>RMS</i> (MPa)	<i>DRMS</i> (MPa)	Comment
Line survey 4	78	65	Good (II)	107,1	90,6	-
Line survey 3	73	61	Good (II)	99,0	83,8	-
Zone (avg)	75	64	Good (II)	100,4	84,9	Competent zone
Zone (avg)	52	44	Fair (III)	57,6	48,7	Fracture zone
Zone (avg)	70	52	Good (II)	91,4	68,8	Dome

Underground mapping in Section S of Mine A

The 33 Level at Section S is currently the deepest level being mined from at Mine A. Stopes in this area are the closest to Section N and it is therefore more likely that geotechnical conditions could be similar. Window mapping and zone mapping were carried out in winzes 33-16S and 33-15A, and line mapping was conducted on both the hangingwall and a pillar adjacent to winze 33-16S where double seam mining had been carried out. Details of these surveys are depicted in Figures 3-8 to 3-11.

The rock mass conditions observed in Section S were generally similar to those seen in the Section D. However, more fracture zones were noted, possibly due to the close proximity of major faults to winze 33-16S. Both *J1* and *J2* fractures were noted in Section S, whereas in Section D, *J1* fractures were prevalent. No domes were observed in the 33-16S and 33-15A winzes of Section S. This could be attributed to the relatively small stope spans in these areas at the time of the mapping. However, domes were mapped in the upper areas of Section S.

A summary of the average *RMR*, *MRMR*, *RMS* and *DRMS* values obtained from the hangingwall in Section S is given in Table 3-5.

Table 3-5 Summary of average RMR, MRMR, RMS and DRMS for the hangingwall in Section S

Mapping Technique	<i>RMR</i>	<i>MRMR</i>	Class	<i>RMS</i> (MPa)	<i>DRMS</i> (MPa)	Comment
Line survey: HW	78	67	Good (II)	110,0	93	Competent
Line survey: dyke	64	53	Fair (III)	82,0	69,0	Fractured
Zone (avg)	53	45	Fair (III)	63	53,3	Fracture Zone
Zone (avg)	68	57	Fair (III)	82	76	Competent

In Section S, the average joint spacing in the **competent zones** is 1 m, ranging from 0,5 m to 3 m. Joints are slightly undulating in the large scale and smooth to rough undulating on the small scale, and contain no infill.

MRMR values ranging between 57-73 were obtained for the hangingwall. These gave *DRMS* values ranging from 69-93 MPa.

Both *J1* and *J2* **fractures zones** were mapped in the 33-15A winze, but only *J1* fracture zones in 33-16S winze. In these fracture zones, the average joint spacing is 0,15 m. *MRMR* values in the hangingwall fracture zones ranged from 40-53, giving *DRMS* values from 55-69 MPa.

A parting above the LG6A chromitite seam was seen in a pillar of winze 33-16S. This is a highly disseminated layer of approximately 5 cm thick. Very poor joints (slickensided with 1 mm talc infill) above and below the parting further weaken the contact. A similar parting was seen in Section D where a large fall of ground had occurred. These weak, gently dipping joints at the LG6A contact with the pyroxenite hangingwall will probably not affect the hangingwall stability as both chrome seams will be mined, but may adversely affect pillar stability.

A single **dyke** area was mapped in Section S during the visits to Mine A. The dyke is a hard, fine-grained dolerite. It is about 3 m wide and continuous over the length of the panel. The dyke is highly jointed and forms blocky ground with an average block size of 150 mm by 200 mm. Sympathetic jointing occurs in the country rock. This sympathetic fracture zone is approximately one third of the thickness of the dyke. No alteration of the country rock was noted at the dyke contact. The contact is irregular large scale, rough undulating, with no infill or alteration.

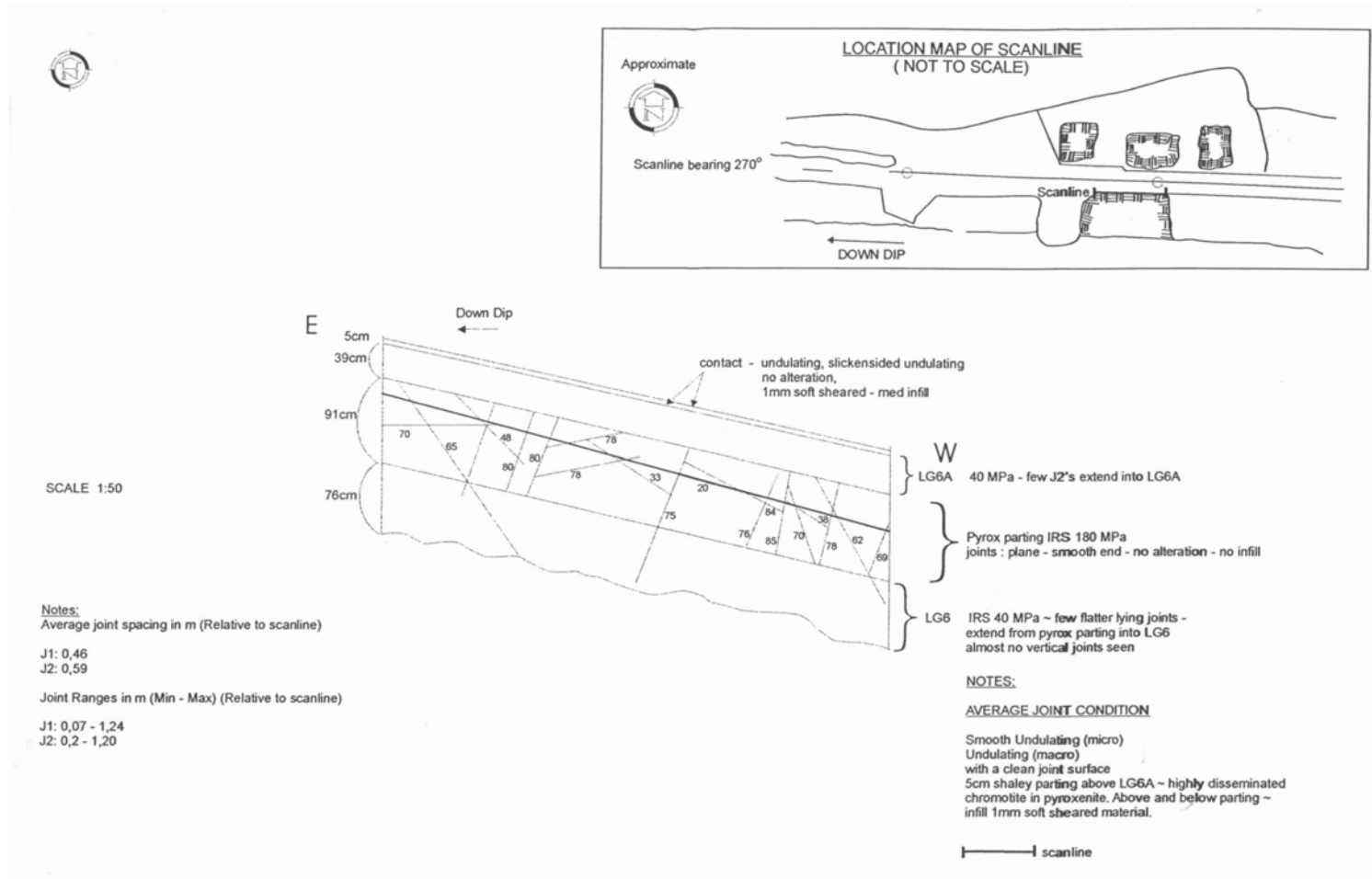

Figure 3-8 Section S 33-16S: Section through pillar in double seam mining area

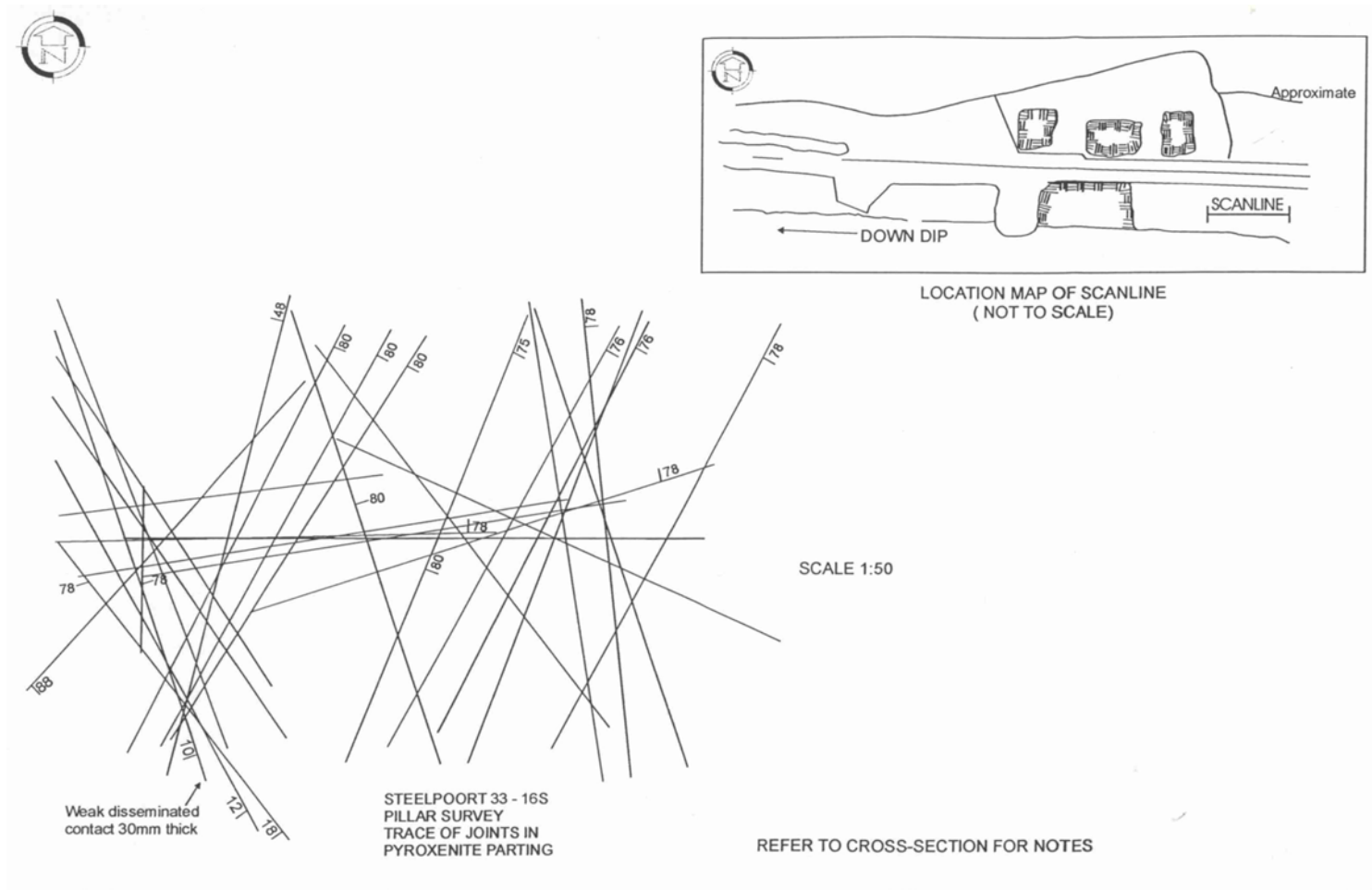

Figure 3-9 Section S 33-16S: Plan view of pillar scanline survey

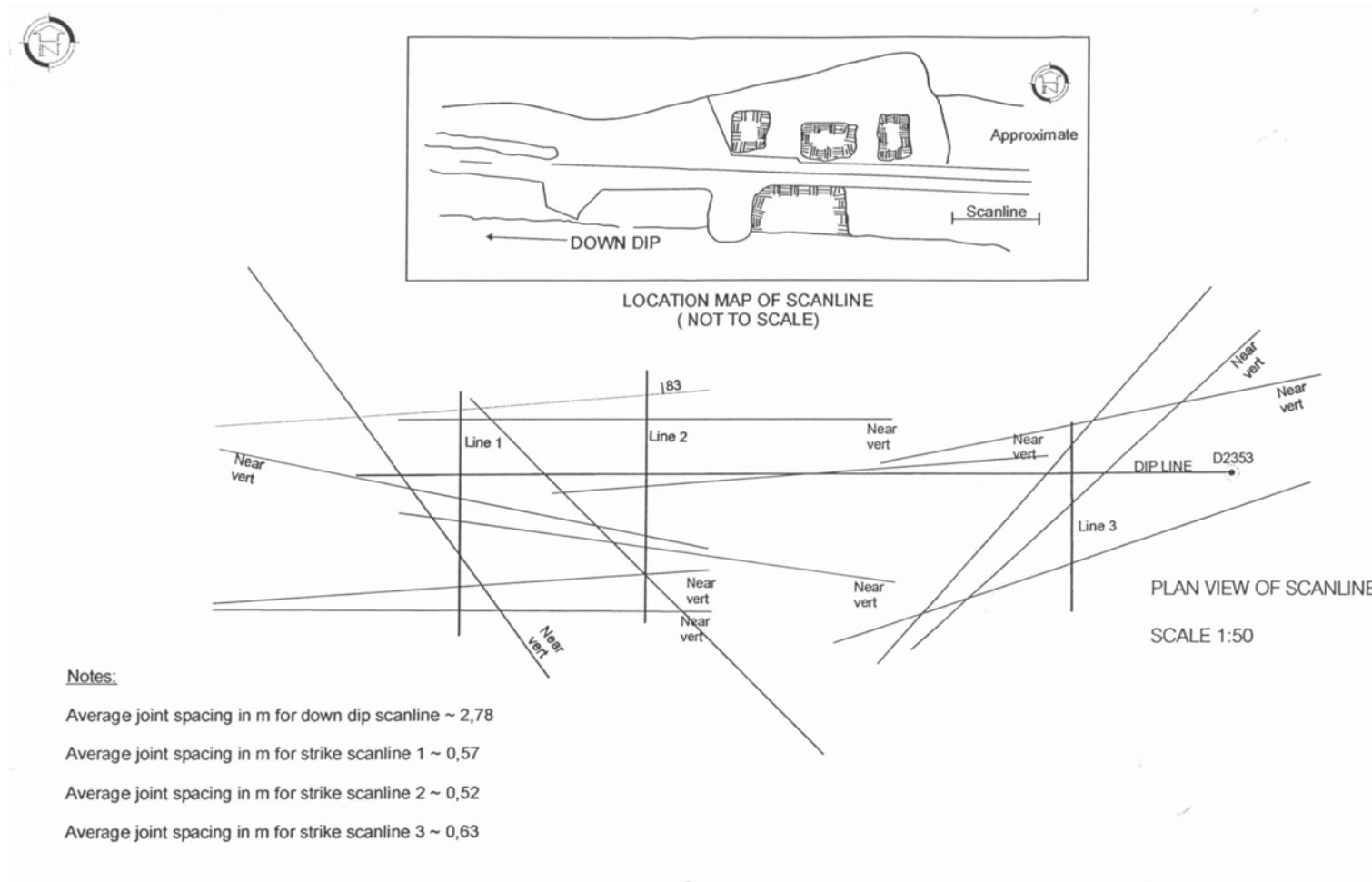
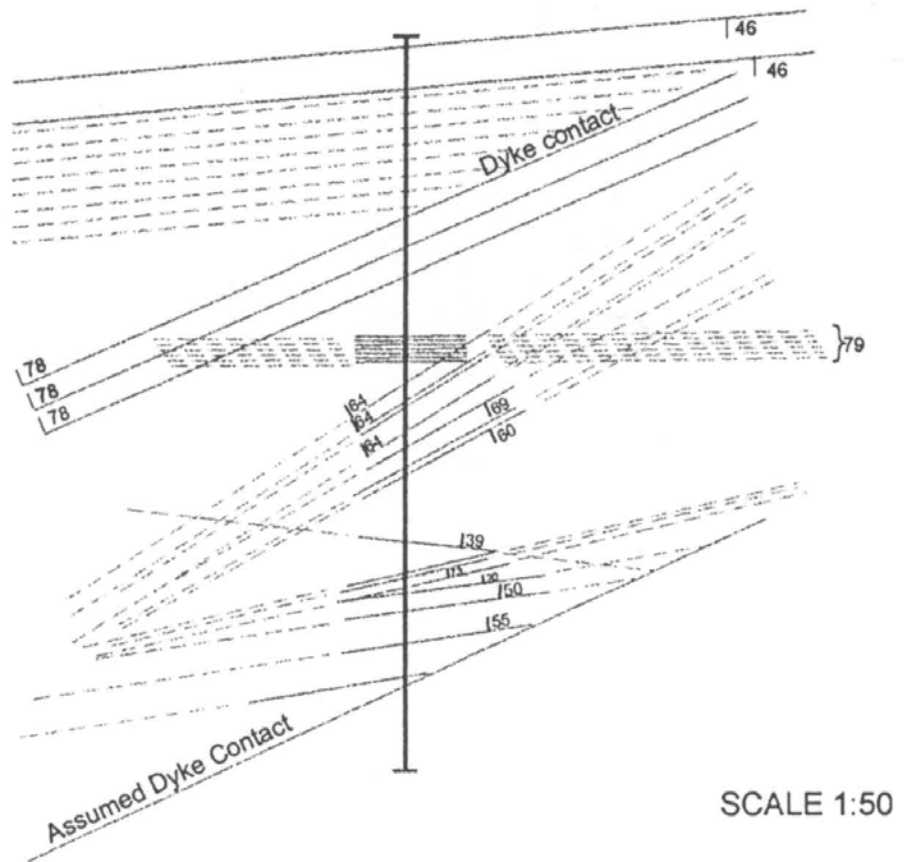

Figure 3-10 Section S 33-16S: Plan view of hangingwall dip and strike surveys



Notes:

Average joint spacing in m ~ 0,11

Range of joint spacing in m (min - max) ~ 0,02 - 0,58

This dyke has created blocky ground which was very unstable forcing a very rapid mapping of the scanline. This involved mapping only joints which intersected the scanline. There are other joints trending \perp to scanline which were not mapped due to the instability of the area.

Figure 3-11 Section S: Plan view of scanline through dyke

Observed failure modes

The instability that was observed and measured at Mines A, B and C were in all cases confined to individual stopes. The falls of ground that was observed did not propagate across regional support pillars. Most of the failures that were recorded occurred as in stope falls of ground. The failures that were observed can be separated into four categories based on the failure modes. These failure categories are:

- Failure through intact material - highly weathered intact material;
- Failure associated with major geological structures - fracture zones;
- Beam failures;
- Failure associated with minor geological structures - dome failures.

It is essential to understand the geological structure of the rockmass that is being mined in because the structure of the rock mass, more specifically, the orientation and strength of the structure defines the failure mode. The mechanism of failure significantly influences the behaviour of a rock mass in response to mining induced stresses and influences the extent to which the failure will propagate into the stope boundaries.

Failure Through Intact Material - Weathered Intact Material

This refers to situations where the intact rock is more weathered either due to close proximity to the surface or to being highly fractured and more weathered due to weathering along the fracture surfaces. A higher degree of weathering is often associated with a higher moisture content - usually from a perched water table.

Failure Associated With Major Geological Structures

Fracture Zone

Fracture zones truncate the rock mass through out the mines at irregular spacings ranging from as much as 500 m to as little as a few meters. These fracture zones are generally, but not always, sub-parallel to the

major joint set that occurs through the mines (J1). The fracture zones vary in width from 0.5m to several 10's of metres and are typically very continuous. They may form a narrow 'band' of unstable hanging wall which tapers out over the length of the fracture zone surrounded by a stable rock mass. Or they may form a region of coalescing fracture zones which are highly weathered and reduce the overall stability of the excavations.

The fracture zones are generally associated with faulting, shearing or intrusions and consequently, with appropriate mapping during the development phase, the occurrence of fracture zones can be anticipated and planned for in the stopes of the mine.

Beam Failure

Beam failure refers to the failure of a layer or beam of intact rock, and it occurs as a combination of failure along a geological structure and failure (in shear) through the intact rock. The beam is usually defined by two or more weak planes in the hanging wall along which failure is initiated. Layering or jointing sub-parallel to mining effectively separate the beam from the overlying rock mass. This block or beam is prevented from failing by the clamping stresses acting on the joints, the shear strength of the intact rock and the strength of the joint planes.

In the case of the beam failures investigated in this project, geological structures (faults or dykes) formed the surface on which failure was initiated. Major joints, with a softening infill (talc or serpentinite) formed release planes along which the beam could slide. In all cases, at least one of the edges defining the beam failed completely or partially in shear. Once failure had been initiated and movement along the discontinuities have occurred the entire beam is carried by the intact edge of the beam.

Failure Associated with Minor Geological Structure - Doming

Doming is the mode of failure which is encountered most frequently in Mine B. It is also responsible for most of the fatalities that have occurred at this mine.

A dome is essentially curved sub horizontal joints that dip away from each other at angles varying from 15° to 45°. The domes have a distinctive long axis which is sub-parallel to the two major joints sets (*J1* and *J2*).

Doming occurs in clusters, with a wide range of domes of different scale riding up on each other to form a complex dome network. The domes vary in length from a few meters to a few tens of meters. The bigger scale domes are frequently intersected by sub-vertical joints forming unstable joint-dome wedges. The domes usually have a continuous talc or serpentinite infill that varies in thickness from about 1mm to 10mm. The infill significantly reduces the strength of the rock mass across the dome plane. Once the dome is undercut, the weight of the undercut rock exceeds the strength of the dome plane and the dome falls.

One of the difficulties associated with designing in-stope support for dome failure is that it is exceptionally difficult to predict the occurrence of doming prior to excavation.

Geotechnical logging of boreholes

During visits to Mine A, eight boreholes relevant to Sections S and D were geotechnically logged and classified. The results from the borehole classification were then compared with the rock mass classification carried out during the underground mapping.

Unfortunately, boreholes WV 19, 21 and 22 are old, and the core was slightly weathered, and had been split for metallurgical testing. In addition, these boreholes were all drilled vertically, so the two major joint sets, *J1* and *J2*, are not well represented due to their vertical orientation.

The condition and location of weak zones and poor quality joints were logged. Conditions that could lead to falls of ground include the presence of joints with weak infill, partings at the LG6A/ hangingwall contact, and friable chromitite. Table 3-6 summarises weak planes logged in the core.

Table 3-6 Weak planes as seen in borehole core.

Condition	Borehole No.	Comments
Parting	None	Seen in pillar in Section S 33-16S and in large FOG area at D
Friable chrome	WV 21: LG6 WV 31: LG6 WV 37: LG6A WV 36: LG6 WV 35: LG6A	Low <i>UCS</i> in point load tests.
Poor joints above LG6A	WV 36 WV 35	150 mm above LG6A poor joint with infill
Pegmatoid	WV 19 WV 36	200 mm in LG6 10 mm pegmatoid lens in LG6 Pegmatoid seen in pillars: base of LG6 in S, base of LG6A D.
Poor contacts between pyrox. and LG6	WV 26 WV 31 WV35 D4	Rock weak and friable Weathered or friable contact Contact faulted: slickensided fractures.

The bottom contact between the chromitite and pyroxenite was often gradational, with the upper contact showing less gradation. The layer of disseminated chromitite, however, is not a significant weak zone.

Curved, slickensided joints with infill seen in the core could possibly be dome joints, which could be responsible for instability and falls of ground in Section S and D.

Comparison of *MRMR* values obtained from borehole cores logged and from underground mapping

Table 3-7 provides a comparison of *MRMR* values obtained from borehole cores logged, and from underground mapping in the 33-16A winze of Section S.

Table 3-7 Comparison of MRMR values obtained from boreholes logged and from underground mapping

Lithological unit	WV 19	WV 21	WV 22	Avg.	WV 35	WV 36	WV 37	Avg.	Avg. UG*
Hangingwall	59	49	59	56	53	48	54	52	62
LG6A	33	37	36	35	32	32	33	32	43
Pyroxenite parting	53	48	47	49	47	32	47	42	43
LG6	38	38	35	37	40	38	31	36	43
Footwall	55	55	45	52	55	40	47	48	-

*Average *MRMR* values from underground mapping of competent zones in the 33-16A winze in Section S.

From this comparison, it can be seen that the *MRMR* values for the borehole logs are generally lower than those obtained from underground mapping. This could be explained as follows:

- The drilling process often opens tight or semi-healed joints that would not be mapped underground and, because of their closed nature, would not affect rock mass characteristics. The higher fracture frequency counted for the core thus gives lower *RMR* and therefore *MRMR* values.
- The difference in *MRMR* values may also be explained if the borehole locations are taken into consideration. Boreholes WV 19, 21 and 22 are positioned closest to Section S (see Figure C-12). The average *MRMR* value for these boreholes is less than those obtained in the underground mapping, but greater than the average obtained for boreholes WV 35 and 37. This trend indicates that rock mass conditions deteriorate slightly from the east to the west, but by less than half a class of the *MRMR* system. It should however be noted that borehole WV 25 (situated to the west of the lease area) is very competent, with average *MRMR* values of 80 for the pyroxenite and 60 for the chromitite (*MRMR* values obtained from reconstructed borehole logs). Thus, the weakening westward trend is only true within the lease area.

Using *MRMR* values, results of *UCS* tests conducted on the core, and by visual inspection of the core, it can be seen that core from borehole WV 36 is weaker than other borehole cores from within Section N. The chromitite

in this borehole is highly friable, and weak joints with infill were noted in the hangingwall. Weaker core from borehole WV 26, south of Section N, was also observed. The conclusion can be drawn that the rock mass conditions could be poorer in the proximity of these boreholes, or else there could be a weak zone stretching from borehole WV 36 through to the south western boundary of the lease area

3.3 Rock mass classification

The field data obtained from the detailed mapping at selected positions at the three mines were used to classify the rock mass according to three different classification systems.

- Bieniawski's Rock Mass Rating System (*RMR*)
- Barton's Tunnelling Index (*Q*)
- Laubscher's Mining Rock Mass Rating (*MRMR*)

The three systems were selected because they are widely used in the mining industry in South Africa and because they constantly developed for the last 20 years, using an extensive range of case studies to improve the reliability of the classification systems.

3.3.1 Bieniawski's Rock Mass Rating System (*RMR*)

The field data were classified using the 1989 version of Bieniawski's rock mass rating system. This version takes the influence of joint orientation and ground water on the rock mass into account.

Table 3-8 summarises the representative *RMR* values that were calculated for the geotechnical zones at the three mines. The data are presented in full in Appendix C.

Table 3-8 Summary of representative *RMR* and *GSI* ratings of geotechnical zones at three chrome mines

Geotechnical Zone	<i>RMR</i>(89)	<i>GSI</i>	Rock Mass Description
Stable	67	62	Good rock
Fracture Zone	38	33	Poor rock
Weathered Zone	33	28	Poor rock
Beam Failure	50	45	Fair rock
Dome	63	58	Good rock

The Geological Strength Index (*GSI*)(Hoek *et al*, 1995) can be easily calculated from $RMR_{(89)}$ using

$$GSI = RMR_{89} - 5 \quad (3.1)$$

The *GSI* is a parameter that was introduced by Hoek, Kaiser and Bawden (1995) to relate the rock mass strength parameters such as *m*, *s* and Young's modulus (*E*), to the easily determined rock mass rating.

3.3.2 Barton's rock mass quality index (*Q*)

The value of *Q* was calculated for each mapped locality at the three mines using Barton's (1974) rock mass quality classification system. Particular care was taken in the rating of the stress reduction factor as this parameter is difficult to determine in the field.

Table 3-9 presents a summary of representative *Q* values calculated for each geotechnical zone identified at the two mines. The data are presented in full in Appendix C.

Table 3-9 Summary of representative *Q* values for identified geotechnical zones

Geotechnical Zone	<i>Q</i>	Rock Mass Description
Stable	10.4	Good
Fracture Zone	2.6	Poor
Weathered	1.5	Poor
Beam	2.8	Poor

Dome	6.42	Fair
------	------	------

According to Bieniawski (1979, 1993), the *RMR* can be calculated from *Q* using:

$$RMR = 9 \text{Log}_e Q + 44 \quad (3.2)$$

Consequently, the geotechnical parameters of the rock mass (*E*, *C* and ϕ) can be calculated.

3.3.3 Laubscher’s Mining Rock Mass Rating (*MRMR*)

The mining rock mass rating was calculated for each of the selected mapping areas at the three mine sites. Particular attention was paid to the adjustments that were applied to the *in situ* ratings. The adjustments account for the change in behaviour of a rock mass when it is excavated. *MRMR* adjusts the *in situ* rating for weatherability of the intact rock, orientation of discontinuities, mining induced stresses and blasting. The “down rating” of the rock mass is essential in the prediction of the behaviour of a rock mass around an excavation.

Table 3-10 presents a summary of *MRMR* and adjustment values representative of the geotechnical zones at the three mines. The data is presented in full in Appendix C.

Table 3-10 Summary of representative *MRMR* values of identified geotechnical zones

Geotech. Zone	<i>RMR</i> (Laub.)	Adjustments				Total Adjustment	<i>MRMR</i>
		Weathering	Orientation	Induced Stress	Blasting		
Stable	65	1	0.9	0.95	0.94	0.804	52
Fracture Zone	46	1	0.75	0.85	0.94	0.599	27
Weathered	39	1	0.85	0.85	0.94	0.679	26
Beam	56	1	0.85	0.95	0.94	0.759	42
Dome	60	1	0.75	0.85	0.94	0.599	36

The Mining Rock Mass Rating system has been designed specifically for mining and takes all the parameters that influence the stability of a rock mass around an excavation into consideration. The flexibility in the adjustment of the *in situ* rock mass rating enables the system to be applied to a range of mining environments.

3.4 Estimation of rock mass properties

The significance of obtaining a rock mass rating is that geotechnical parameters for the rock mass, such as E , m , s , C and ϕ can be calculated from the rating. These geotechnical parameters refer to the **rock mass** rather than to the intact rock. Analytical methods can then be used to predict the behaviour of the rock mass. In addition, the stability and support requirements for an excavation within a rock mass can be estimated using these classification systems.

Numerical analysis programs use, in addition to some of the material properties previously calculated, elastic and Hoek-Brown rock strength properties as input parameters. These strength properties for chromitite, the pyroxenite parting and pyroxenite host rock were estimated using the methods described in Hoek (1998).

Elastic properties

The elastic properties Young's modulus (E) and Poisson's ratio (ν) were determined from laboratory tests. Poisson's ratio (ν) did not deviate significantly from 0,2 for both the chromitite and pyroxenite and this value was used in all cases. Young's modulus (E_M) for the rock mass was determined using the following modification of Serafim and Pereira (1983) in Hoek (1998):

$$E_M = \sqrt{\frac{\sigma_{ci}}{100}} 10^{\left(\frac{GSI-10}{40}\right)} \quad \text{for } \sigma_{ci} > 100 \text{ MPa} \quad (3.3)$$

$$E_M = 10^{\left(\frac{GSI-10}{40}\right)} \quad \text{for } \sigma_{ci} \leq 100 \text{ MPa} \quad (3.4)$$

where:

σ_{ci} is the uniaxial compressive strength of the intact rock;

GSI is the Geological Strength Index as described in Hoek (1998).

Variation in E_M will not affect the numerical model significantly and it was therefore kept constant for each material type. The values of E_M for each material are listed in Table 3-11.

Table 3-11 Elastic properties for the different materials

Property	Chromitite	Pyroxenite parting	Pyroxenite host rock
E_M	9 GPa	50 GPa	75 GPa
ν	0,2	0,2	0,2

Hoek-Brown Properties

The generalised Hoek-Brown failure criterion (Hoek, 1998) for jointed masses is defined by:

$$\sigma_1 = \sigma_3 + \sigma_{ci} \left(m_b \frac{\sigma_3}{\sigma_{ci}} + s \right)^a \quad (3.5)$$

where:

σ_1 and σ_3 are the maximum and minimum effective stresses at failure;

m_b is the value of the Hoek-Brown constant m for the rock mass;

s and a are constants which depend on the rock mass characteristics;

σ_{ci} is the uniaxial compressive strength of the intact rock pieces.

The Hoek-Brown parameter m_b for the rock mass is determined from m_i (Hoek-Brown constant for intact rock) and the GSI as follows:

$$m_b = m_i \exp\left(\frac{GSI - 100}{28}\right) \quad (3.6)$$

For $GSI > 25$, i.e. rock masses of good to reasonable quality, the original Hoek-Brown criterion is applicable with:

$$s = \exp\left(\frac{GSI - 100}{9}\right) \quad (3.7)$$

and $a = 0,5$ in Equation 3.5

For the residual strength condition, the following relations for disturbed rock mass (Hoek, 1990) were used:

$$m_r = m_i \exp\left(\frac{GSI - 100}{14}\right) \quad (3.8)$$

$$s_r = \exp\left(\frac{GSI - 100}{6}\right) \quad (3.9)$$

where:

m_r and s_r are the are Hoek-Brown parameters for residual strength.

The values of m_i and σ_{ci} were obtained from laboratory testing carried out at the University of the Witwatersrand. A distribution of GSI was obtained from the rock mass classifications carried out. The variation in the properties of chromitite will have a greater effect on the stability of the pillar. The GSI for the pyroxenite parting was significantly lower than for the pyroxenite host rock. The pyroxenite parting and host rock were therefore modelled as different materials with the following strength properties obtained from the mean of the m_i and σ_{ci} and the GSI (Table 3-12):

Table 3-12 Hoek-Brown properties of the pyroxenite parting and host rock

Material	σ_{ci}	m_b	s	m_r	s_r
Pyroxenite Parting	180	13,0	0,062	5,4	0,0155
Pyroxenite Host	180	17,3	0,145	9,3	0,0550

The GSI obtained for chromitite from boreholes in Section N was lower than that for Sections D and S and was therefore considered separately. The distributions of m_i and σ_{ci} were determined from all available information, except that high values of σ_{ci} from deep boreholes were excluded.

Table 3-13 is a summary of the distributions of the chromitite properties. *GSI (S)* and *GSI (N)* refer to the *GSI* for Sections S and N respectively.

Table 3-13 Summary of the distributions of chromitite properties

Property	Type of Distribution	Number of Samples (<i>N</i>)	Mean (μ)	Standard Deviation (σ)	Moment of Skewness (β)
m_i	Pearson VI	19	32,6	8,4	1,1
σ_{ci}	Lognormal	106	42,4	29,8	2,4
<i>GSI (S)</i>	Normal	18	43,3	3,4	1
<i>GSI (N)</i>	Normal	5	69,4	3,3	1

3.4.1 Estimation of joint properties

Vertical and horizontal joints were modelled in the analysis for Section N. The properties were initially determined using the equation presented by Barton and Bandis (1990), which is discussed in Hoek (1998):

$$\tau = \sigma_n \tan \left(\phi_b + JRC \log_{10} \left(\frac{JCS}{\sigma_n} \right) \right) \quad (3.10)$$

where:

σ_n is the normal stress;

ϕ_b is the basic friction angle of the surface;

JRC is the joint roughness coefficient;

JCS is the joint wall compressive strength.

The roughness of joints were measured in the field, using a joint comb, and *JRC* values were estimated from the Barton and Choubey (1977) roughness profiles. The scale corrections proposed by Barton and Bandis (1990) were applied.

$$JRC_n = JRC_o \left(\frac{L_n}{L_o} \right)^{-0,02JRC_o} \quad (3.11)$$

where:

JRC_o and L_o (length) refer to the 100 mm laboratory scale samples;
 JRC_n and L_n refer to the *in situ* block sizes.

The JRC_o was reasonably consistent and was therefore not varied.

The JCS was determined from the σ_{ci} of the weakest material that the joint passes through. The σ_{ci} was scaled down by factor of 0.8 to account for weathering of the joint material. Scale corrections for JCS (Barton and Bandis, 1982) were also applied as follows:

$$JCS_n = JCS_o \left(\frac{L_n}{L_o} \right)^{-0,03JRC_o} \quad (3.12)$$

where:

JCS_o and L_o refer to 100 mm laboratory scale samples;
 JCS_n and L_n refer to *in situ* block sizes.

Stacey and Page (1986) suggested using a basic friction angle (ϕ_b) of 30°. This value corresponds with the mean of a distribution of residual friction angles measured in actual rock joints for a variety of rock types.

Typical horizontal joints were taken as 12 m in length, while the vertical joints were taken as 5 m in length. The joint properties are summarised in Table 3-14.

Table 3-14 Summary of joint properties (Barton-Bandis).

Joint Orientation	JCS_n	JRC_n	ϕ_b
Horizontal	15,2 - 59,8	2,7	30°
Vertical	16,9 - 66,4	2,9	30°

After carrying out analyses with joint properties, it became apparent that the Barton-Bandis model in the finite element analysis was not resolving

the joint behaviour correctly. It was then decided to use the Mohr-Coulomb model for joint behaviour. This model is represented as follows:

$$\tau = c + \sigma_n \tan \phi \quad (3.13)$$

where:

c is the cohesive strength of the surface of the joint;

ϕ is the angle of friction.

The range of normal stresses acting on the vertical and horizontal joints was determined by running the model without allowing slip on the joints. Mohr-Coulomb properties were then determined by fitting Mohr-Coulomb curves to the Barton-Bandis curves, with the determined properties, within the range of normal stresses for both horizontal and vertical joints. The equivalent Mohr-Coulomb properties are represented in Table 3-15.

Table 3-15 Summary of joint properties (Mohr-Coulomb)

Joint Orientation	$c(\text{MPa})$	ϕ
Horizontal	0,70 - 0,72	28,1 - 29,7°
Vertical	0,74 - 0,77	28,1 - 29,8°

3.4.2 Talcose and Serpentinised Joints

Talcose and serpentinised joints were not considered during the reliability analysis as these joints occur infrequently and should form part of the general pillar design. However since they do occur, the effect of these joints must be taken into account as special cases. As there was no information available on the strength of these discontinuities, values were assumed after consulting a table of shear strength of filled discontinuities and filling materials (Barton, 1974). Discontinuities with Bentonite (montmorillonite) clay infill were considered to have similar properties to talc or serpentine. Table 3-16 shows the Mohr-Coulomb properties for talcose / serpentinised joints.

Table 3-16 Joint properties for talcose/serpentinised joints

c(MPa)	ϕ
0,02	11,5°

3.5 Statistical analysis of geotechnical parameters

A statistical analysis of some of the geotechnical parameters was carried out in order to improve the understanding of the rock properties and their variability, and to choose appropriate values and distributions for probabilistic and numerical analyses. The parameters analysed statistically are:

- Rock Mass Rating (*RMR*);
- Uniaxial compressive strength (*UCS*);
- The Hoek-Brown rock mass constant *m* for intact rock, m_i ;
- Joint roughness coefficient (*JRC*).

Probability density functions were only determined for the first three parameters.

3.5.1 Statistical analysis of the *RMR* for chromitite

From the limited *RMR* data available for the chromitite of Sections D, N and S, it is clear that the *RMR* for Section N is lower than for Sections D and S (Figure 3-12). However, *RMR* data for Section N were obtained from borehole logging only, and, as mentioned before, borehole log data are generally lower than those obtained from underground mapping.

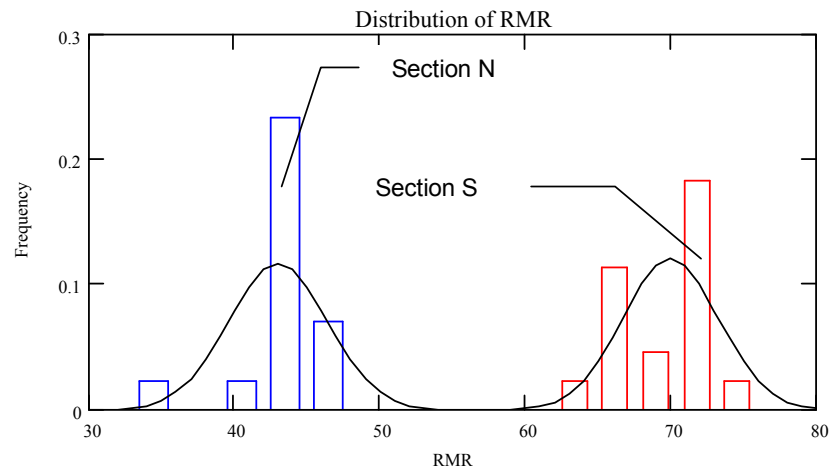

Figure 3-12 Frequency distributions of the RMR values for the chromitite of Sections D, N and S

A statistical analysis of this *RMR* data shows that the mean and standard deviation for Sections D and S are 70 and 3,3 respectively, and 43 and 3,4 for Section N.

3.5.2 Statistical analysis of the *UCS* of chromitite and pyroxenite

Separate statistical analyses of the *UCS* values for the chromitite of Sections D and S, and the *UCS* values for Section N, show a remarkable resemblance (Figure 3-13)

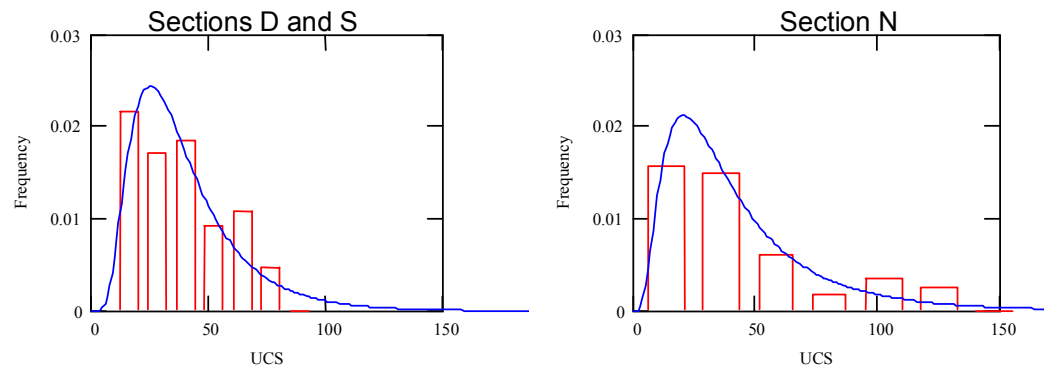

Figure 3-13 Frequency distributions of the UCS values for the chromitite of Sections D, S and N

The *UCS* data are based on laboratory and point load tests carried out on chromitite borehole cores from the relevant areas. *UCS* data from boreholes WV19, 21, 22, 26, 31, and 35 were used for Section N.

According to this analysis, the mean *UCS* values for the chromitite of Sections D and S and Section N are 40,6 MPa and 45,4 MPa respectively. The corresponding standard deviations are 20,3 MPa and 36,9 MPa.

The *UCS* data available for pyroxenite are limited, and it was therefore assumed that the same values are applicable to the pyroxenite partings and hangingwalls of Sections D and S and Section N. A statistical analysis of these data is shown in Figure 3-14 below. The mean value for the *UCS* of the pyroxenite is 138 MPa, and the standard deviation is 50,7 MPa.

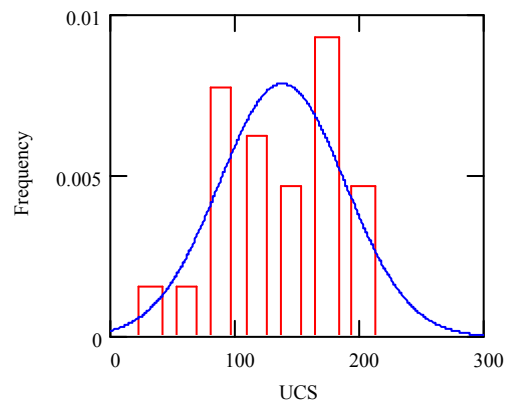

Figure 3-14 Frequency distribution of the UCS values for pyroxenite.

3.5.3 Statistical analysis of the m_i values for chromitite

The rock mass constant, m_i , forms an integral part of characterising the material behaviour of chromitite with the Hoek-Brown failure criterion. The statistical analysis of this parameter was based on data from laboratory tests carried out at the University of the Witwatersrand. According to the statistical analysis shown in Figure 3-15, the mean and standard deviation for m_i are 32,6 and 8,4 respectively.

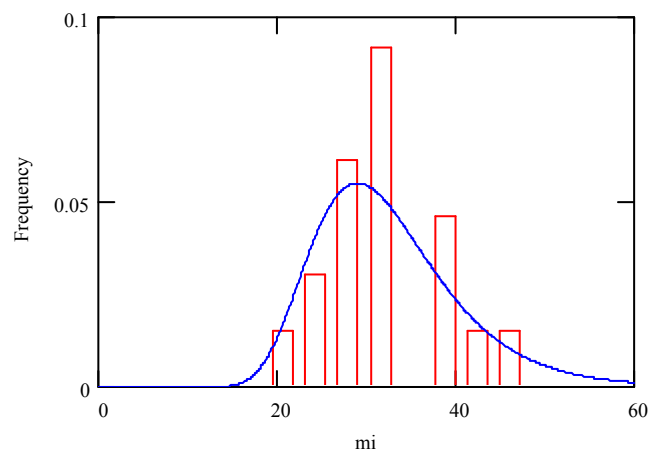

Figure 3-15 Frequency distribution of m_i values for chromitite.

3.5.4 Statistical analysis of the *JRC* values for chromitite and pyroxenite

JRC values were obtained from line surveys, using a joint comb and the Barton & Chouby chart. Histograms of the *JRC* values for chromitite and pyroxenite are shown in Figure 3-16 below.

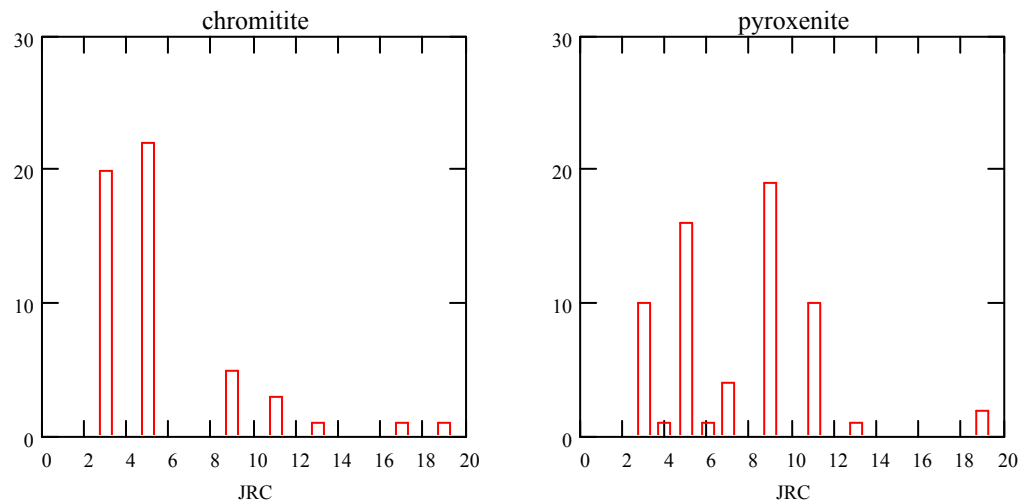

Figure 3-16 Histograms of *JRC* data for the chromitite and pyroxenite.

Most joints in the chromitite have *JRC* values between 3 and 5, whilst most joints in the pyroxenite have *JRC* values between 3 and 11. The numerical analysis program used for this project is limited to the use of only one set of joint properties. Thus, only one *JRC* value could be used for joints that cut through both the pyroxenite and the chromitite. It was considered that the joints within the chromitite would influence the behaviour of the pillars more than the jointing in the pyroxenite, and a *JRC* value of 4 was therefore used in the numerical analyses.

4 Risk assessment

4.1 Literature review

A risk assessment of the South African mining industry, SIMRISK 401 (Gürtunca, 1997), was completed in 1997, involving the identification of all safety and health hazards and the quantification of the risks. This research project did not only review existing data to determine current risks, but also gathered information on likely changes in mining conditions and circumstances to develop short, medium, and long term research strategies.

One part of the SIMRISK 401 project, (Jager, 1997), relates to the current and future rock engineering risks in the shallow hard rock mining sector (excluding gold and platinum). Some relevant conclusions resulting from this part of the SIMRISK 401 project, can be summarised as follows:

- In the rock engineering functional area for the mentioned mining sector, the issues related to technology and application of technology appeared to be the major need. Most issues related to rockfall accidents are often the result of less than adequate understanding by management of rock engineering principles and the consequences of non-adherence to these principles.
- The occupational safety risk for rock engineering in this mining sector was found to be 14,0 %, compared with 43,6% for mechanical equipment and 38,0% for mining operations.
- Only 3% of the total rock engineering related fatalities occurred in this mining sector.
- In terms of research and technology development, rockfalls show the second highest need for research after dust in this mining sector.
- Due to expected changes in legislation concerning mineral rights, the number of small, shallow hard rock mines, and hence people at risk, is likely to increase. Thus, if research to develop appropriate and

affordable solutions and improved training is not carried out, the casualty figures in this sector are likely to increase.

- Current information gathered and stored in SAMRASS is very limited and makes it difficult, if possible, to assess or analyse rockfall accidents. Additional information would greatly enhance the value of casualty data analysis and would enable problem areas to be defined and areas for research to be determined. It would also allow the monitoring and evaluation of new management strategies on safety performance.
- There was no major disagreement between the risk assessment data and the analysis of the accident statistics, except probably in the proportion of assigned causes of accidents.

Joughin *et al* (1998) analysed 328 FOG accident records for the period 1988 to 1997, including 55 fatal accident records available from the South African Mines Reportable Accident Statistics System (SAMRASS) and back-analysed 42 fatal accidents using empirical methods as part of the SIMRAC research project OTH 411. These accident records are also for the shallow hard rock mining sector, excluding gold and platinum mines. Some of the conclusions drawn from this research are:

- The FOG fatality rate for chrome mines had an upward trend and had been significantly higher than the rest of the commodities over the period 1995 to 1997.
- FOG accidents on diamond, chrome, copper and iron ore mines made up 26, 29, 20 and 15 percent respectively of the total number of accidents in this mining sector.
- Most FOG accidents in diamond mines occur in mines with tabular orebodies.
- The most common forms of failure were wedges, blocky hangingwalls and weak hangingwalls.
- Only 10 percent of rocks had dimensions greater than 5,9 m x 2,8 m x 1,2 m.
- In most of the fatal FOG accidents, support standards were inadequate or no support standards existed. This could be attributed to the lack of

rock engineering involvement and the fact that support standards are often compiled by mine management with very little understanding of the geotechnical conditions of the rock mass.

4.2 Discussion

As suggested by the title of the SIMRISK 401 study, an attempt was made to identify the safety and health hazards and quantify the risks in the South African mining industry. Unfortunately, time constraints and the limitations of the workplace risk assessment and control (WRAC) method used, resulted in only a semi-quantitative risk assessment.

There is, however, some synergy between the findings of the SIMRISK 401 study and the OTH 411 research project on the review of falls of ground problems. The identified need for the application of rock engineering technology, especially on the small mines within the mentioned mining sector, is very relevant and the lack of application appears to be one of the major factors contributing towards fall of ground accidents. Small mines are often under capitalised and are therefore reluctant to use rock engineering expertise or to implement the latest technologies and equipment that will improve safety. Instead, they prefer to rely on old technology and “gut” feel to operate their mines at the lowest possible cost. This also has a negative impact on the training of staff, in particular hazard awareness training, and the implementation of codes of practice for preventing rockfall accidents.

The safety risks calculated for rock engineering (14%), compared with other functional areas such as mechanical equipment (43,6%) and mining operations (38%), could be misleading, since the type of accident related to rock engineering is almost exclusively rockfalls. On the contrary, other functional areas comprise of several hazards such as electricity, machinery, shafts, explosives, etc., none of which has a risk as high as falls of ground.

It is believed that some of the “blocky” and “weak” hangingwall forms of failure described in the SAMRASS records could be due to beam failure. It is therefore recommended that beam failure (buckling, shear and crushing failure) be considered as one of the potential failure modes during FOG investigations.

For reasons discussed above, the actual root causes of rockfall accidents could neither be identified, nor quantified in the SIMRISK 401 project. Joughin *et al* (1998) found that, even after analysing the accident information stored in SAMRASS, and all the available fatal accident reports for falls of ground, root causes were still difficult to identify and suggested that the fault-event tree methodology to risk assessment be used to identify significant hazards and quantify the significant risks. The fault-event tree analysis approach used to assess the significant risks associated with unstable stope panels in the shallow hard rock mining sector (Section 4.3) has been used successfully to identify the relevant root causes.

4.3 Fault-event tree analysis approach to risk assessment

The failure of any system, e.g. instability of a stope span, is seldom the result of a single **cause**, or **fault**. Failure usually results after a combination of faults occurs in such a way that the factor of safety of the system falls to below unity. A disciplined and systematic approach is therefore required to determine the correct logic that controls the failure of the system and to analyse the potential consequences of failure. One such approach, the **Fault-Event Tree Analysis** (FETA), is a quantitative or qualitative technique by which conditions and factors that can contribute to a specified undesired incident (called the **top fault**) are deductively identified, organised in a logical manner, and presented pictorially. It can also be defined as a deductive failure analysis, which focuses on one particular undesired fault and which provides a method for determining causes of the fault.

The shallow hard rock mining sector covers a wide range of mines, orebody geometries and mining methods. Therefore, factors contributing towards the stability/instability of stope spans on one mine will not necessarily be applicable to another mine. Hence, the risk assessment carried out as part of this study is aimed at identifying all the significant hazards associated with stope panel stability in a systematic manner, and to assess the associated significant risks. The risk assessment was based on the FETA technique described in Appendix D.

First, the **significant hazards associated with stope panel collapses were identified using the information obtained from the literature survey, site visits and personal experience**. These hazards, or factors governing the stability of stope panels, are listed in Table 4-1.

The significant hazards were then analysed systematically to form a cause tree. Probabilities of occurrences were then allocated based on a judgemental basis to form a fault tree. The potential risks associated with panel instability were then assessed by developing an event tree. The complete fault-event tree is included in Appendix E. The spreadsheet format used facilitates the risk analysis and sensitivity analyses using different probabilities for the root causes.

The potential risks associated with stope panel collapses depend on factors such as the size of the collapse relative to the area being assessed, and the probability that people, equipment or production could be exposed to the collapse. These factors vary from mine to mine and cannot be assessed on an industry basis. However, the risks associated with stope panel collapses could be assessed if it is assumed that the size of the collapse, the number of people being exposed, and the value of the equipment and potential production losses are fixed.

A sensitivity analysis to illustrate the effect of the different root causes on the risk 'loss of life', is illustrated in Table 4-2. It is assumed that the probability of adverse jointing conditions is 'very high'.

Table 4-1 Factors governing the stability of stope spans

Threat of stope panel collapse	
1	Threat of unstable rock mass AND
1.1	Threat of inadequate rockwall strength (unsupported) AND
1.1.1	Threat of inadequate in situ rock mass strength OR
1.1.1.1	Inadequate rock mass strength due to adverse geology OR
1.1.1.1.1	Weak intact rock OR
1.1.1.1.2	Deterioration of rock on exposure (e.g. weathering, time-dependant failure) OR
1.1.1.1.3	Adverse geological structure
1.1.1.1.3.1	Intersected by large discontinuity OR
1.1.1.1.3.1.1	Weak contact plane (smooth, infill material) OR
1.1.1.1.3.1.2	Adverse orientation
1.1.1.1.3.2	Adverse parting plane (closely spaced causing thin beams, weak plane due to infill) OR
1.1.1.1.3.2.1	closely spaced causing thin beams OR
1.1.1.1.3.2.2	Weak contact plane (smooth, infill material)
1.1.1.1.3.3	Adverse jointing (flat dipping joints)
1.1.1.1.3.3.1	Weak contact plane (smooth, infill material) OR
1.1.1.1.3.3.2	High joint frequency OR
1.1.1.1.3.3.3	Adverse joint orientation
1.1.1.2	Inadequate rock mass strength due to adverse groundwater conditions
1.1.2	Threat of mining induced damage due to poor blasting
1.1.2.1	Blasting standards inadequate OR
1.1.2.1.1	Blast design inadequate OR
1.1.2.1.2	Blast standard does not comply with blast design
1.1.2.2	Application of blasting standards inappropriate
1.1.2.2.1	Blast standard selected inappropriate OR
1.1.2.2.1.1	Blast standard selected inappropriate for conditions OR
1.1.2.2.1.2	Incorrect assessment of ground conditions
1.1.2.2.2	Blast standard not properly applied
1.2	Threat of inappropriate stope span (geometry)
1.2.1	Standards for stope geometry inadequate / incorrect OR
1.2.1.1	Excavation geometry designed incorrectly (too wide, inappropriate shape, inappropriate orientation) OR
1.2.1.1.1	Use of inappropriate excavation design methodology OR
1.2.1.1.1.1	Incorrect assessment of potential failure modes (wedge failure, beam failure, block failure) OR
1.2.1.1.1.2	Incorrect assessment of boundary conditions (high or low horizontal stress) OR
1.2.1.1.1.3	Use of inappropriate analysis tool OR
1.2.1.1.1.4	Lack of knowledge about correct design methodology
1.2.1.1.2	Incorrect application of design methodology
1.2.1.1.2.1	Use incorrect rock mass parameters OR
1.2.1.1.2.2	Use limited rock mass data OR
1.2.1.1.2.3	Inadequate monitoring OR
1.2.1.1.2.4	Incorrect interpretation of data OR
1.2.1.1.2.5	Incorrect interpretation of analyses results OR
1.2.1.1.2.6	Calculation error
1.2.1.2	Standard for excavation geometry does not comply with excavation design
1.2.2	Incorrect application of standards for excavation geometry
2	Threat of inadequate support capacity
2.1	Inadequate permanent support capacity OR
2.1.1	Inadequate design of permanent support capacity OR
2.1.2	Standard / procedure for permanent support strengths do not comply with support design OR
2.1.3	Capacity of installed permanent support do not comply with support standard (peak strength too low, yield strength too low, yieldability too little, too short) OR
2.1.4	Quality of installed permanent support poor
2.1.5	Permanent support material inadequate (e.g. excessive rust, expired grout, weak raw material)
2.2	Inadequate temporary support capacity
2.2.1	Inadequate design of temporary support capacity OR
2.2.2	Standard / procedure for temporary support strengths do not comply with support design OR
2.2.3	Capacity of installed temporary support do not comply with support standard OR
2.2.4	Quality of installed temporary support poor OR
2.2.5	Temporary support material inadequate (e.g. excessive rust, weak raw material)

Table 4-2 Sensitivity analysis to illustrate the effect of the root causes on the risk of loss of life.

	Allocated Probability											
Inadequate support capacity	c	m	m	m	m	m	m	m	m	m	m	m
Std. for excav. geometry does not comply with design	m	c	m	m	m	m	m	m	m	m	m	m
Incorrect assess. of pot. failure modes	m	m	c	m	m	m	m	m	m	m	m	m
Incorrect assess. of boundary conditions	m	m	m	c	m	m	m	m	m	m	m	m
Use of inapp. analysis tools	m	m	m	m	c	m	m	m	m	m	m	m
Inadequate design knowledge	m	m	m	m	m	c	m	m	m	m	m	m
Use incorrect rock mass parameters	m	m	m	m	m	m	c	m	m	m	m	m
Limited rock mass data base	m	m	m	m	m	m	m	c	m	m	m	m
Inadequate monitoring	m	m	m	m	m	m	m	m	c	m	m	m
Incorrect data interpretation	m	m	m	m	m	m	m	m	m	c	m	m
Incorrect interpr. of analysis results	m	m	m	m	m	m	m	m	m	m	c	m
calculation error	m	m	m	m	m	m	m	m	m	m	m	c
Risk (Life)	0,01	0,007	0,007	0,007	0,007	0,007	0,007	0,007	0,007	0,007	0,007	0,007

m = 'medium' = 1×10^{-3}

c = 'certain' = 1

4.4 Conclusions

The identified significant hazards can be grouped into the following main categories:

- inadequate rock wall strength due to *in situ* rock mass conditions;
- inappropriate stope span (span too wide for the prevailing geotechnical conditions);
- inadequate support capacity (strength).

Stope panel collapses could occur only if the rock mass is unstable **AND** the installed support capacity is inadequate. Also, the rock mass could become unstable only if the rock mass strength is inadequate **AND** the stope span is inappropriate. Therefore, even 'good' ground conditions has a limit in terms of stable stope spans and, the stability of stope spans depends on the capacity of the installed support and the stope span being used. The cost implications associated with too short spans on the one hand and too much support on the other hand should be considered during the detailed design stage.

The sensitivity analysis shows that all the root causes are equally important in terms of risk. The conclusion can be made that, although this is not entirely true, the accuracy of a design for stable stope spans could be reduced significantly by even one aspect such as a limited rock mass database. It is therefore important that all aspects of the design process be considered by means of a systematic approach.

Considering the significant hazards identified in the risk assessment, it is important that a systematic engineering approach to stope panel design be followed. Such an approach should include the following root causes identified in the FETA:

- proper rock mass characterisation;
- correct assessment of potential failure modes;
- estimation of rock mass properties;

- identification of potential failure modes;
- correct assessment of boundary conditions;
- monitoring of slope stability;
- use of appropriate stability analysis techniques;
- knowledge of the design process;
- correct interpretation of rock mass data and analyses results.

The negative affect of using an inappropriate design methodology or incorrect application of the design methodology on the probability of an unstable slope span is illustrated effectively using the FETA.

5 Stability analyses

5.1 Stability analyses based on rock mass classification

This work described in Section 3 included detailed geotechnical mapping and classification of the rock mass at three chrome mines. In this section, the rock mass ratings and their corresponding stable stope spans are assessed in terms of the observed stability.

The purpose of this investigation is to assess the applicability of rock mass classification systems in the determination of safe stope spans in shallow mines. Three of the existing systems were selected for further analysis. The classification systems are

- Bieniawski's (1989) Rock Mass Rating (*RMR*)
- Barton et al. (1974) Rock Mass Quality Index (*Q*)
- Laubscher's (1980) Mining Rock Mass Rating (*MRMR*)

These systems were selected as they are the most frequently used in the mining industry and have been continually developed over a period of more than twenty years and are considered to produce the most realistic and reliable results. In addition, these rock mass classification systems consider the same influencing parameters when describing the *in situ* rock mass.

Bieniawski's RMR (1989 and 1993) and stability graph (Figure 2-2), Barton's Q value (1974) and Hutchinson and Diederich's (1996) stability graph (Figure 2-3), and Laubscher's MRMR (2001) and stability index graph (Figure 2-4) were used to estimate stable unsupported stope spans for the rock mass classifications carried out on three different chrome mines. The rock mass classification data is summarised in Appendix C.

The estimated stable slope spans corresponding with the three rock mass classifications systems for Mines A, B and C are summarised in Tables 5-1, 5-2 and 5-3 respectively.

Table 5-1 Mine A – Estimation of stable slope spans based on RMR, Q and MRMR ratings

	RMR	MRMR	Q	Stable Span (m)			Comment
				RMR	MRMR	Q	
1	74	53	7	4	35	11	stable
2	61	41	9	3	22	12	stable
3	57	36	8	3	17	11	stable
4	44	25	2	1	8	8	failed
5	44	32	5	1	15	10	stable
6	74	51	11	4	33	18	stable
7	52	34	2	2	17	8	failed
8	51	31	4	2	15	10	failed
9	74	65	19	4	67	20	stable
10	51	29	1	2	13	6	failed
11	48	29	4	2	13	10	failed
12	85	50	7	5	33	11	stable
13	42	29	2	1	13	8	failed
14	45	28	2	1	13	8	failed
15	75	53	4	4	33	10	stable
16	31	25	2	1	8	8	failed
17	51	28	1	2	13	6	failed
18	72	44	9	4	25	12	failed
19	47	39	3	2	22	9	failed
20	47	45	2	2	25	8	failed

Table 5-2 Mine B– Estimation of stable stope spans based on *RMR*, *Q* and *MRMR* ratings

	RMR	MRMR	Q	Stable Span (m)			Comment
				RMR	MRMR	Q	
1	70	50	11	4	33	18	stable
2	67	50	11	4	33	18	stable
3	67	34	11	4	15	18	failed
4	70	29	11	4	13	18	failed
5	75	40	12	4	22	18	stable
6	60	49	11	3	33	18	failed
7	65	41	11	3	22	18	failed
8	68	42	11	4	22	18	failed
9	75	29	11	4	13	18	failed
10	70	28	11	4	13	18	failed
11	70	50	11	4	33	18	stable
12	67	45	11	4	25	18	stable
13	70	49	10	4	33	17	stable
14	65	35	12	4	15	18	stable
15	75	35	12	4	15	18	stable
16	67	40	10	4	22	17	failed
17	70	59	12	4	50	18	stable
18	70	50	11	4	33	18	stable
19	68	33	11	4	15	18	failed
20	75	52	12	4	33	18	stable
21	68	48	4	4	33	10	stable
22	60	27	9	3	13	12	failed
23	60	31	9	3	13	12	failed
24	65	26	7	4	13	11	failed
25	55	27	9	3	13	12	failed
26	75	52	12	4	33	18	stable
27	70	49	11	4	33	18	stable

Table 5-3 Mine C– Estimation of stable stope spans based on *RMR*, *Q* and *MRMR* ratings

	RMR	MRMR	Q	Stable Span (m)			Comment
				RMR	MRMR	Q	
1	77	36	4	4	15	10	failed
2	77	55	8	4	44	11	failed
3	67	41	6	4	22	10	failed
4	72	58	13	4	50	18	stable
5	59	38	1	3	17	6	failed
6	69	42	7	4	20	11	failed
7	54	43	3	3	20	9	failed
8	72	49	12	4	33	18	failed
9	74	55	13	4	44	18	failed
10	77	31	4	5	13	10	failed
11	49	40	9	3	22	12	stable
12	47	37	9	3	15	12	failed
13	72	42	6	4	22	10	failed
14	57	38	5	3	17	10	failed
15	72	61	14	4	54	18	stable
16	67	41	6	4	22	10	failed
17	77	61	13	5	54	18	stable
18	67	55	32	4	44	26	stable
19	58	36	8	3	44	11	failed
20	69	59	13	4	54	18	failed
21	55	29	3	3	13	9	failed
22	69	30	6	4	13	10	stable
23	77	59	25	5	54	21	stable
24	54	33	6	3	15	10	stable
25	62	35	8	4	15	11	failed
26	77	61	13	5	53	18	stable
27	58	32	3	3	13	9	stable

The following conclusions could be drawn from this assessment:

- The *MRMR* classification system provides the most reliable results. Back analysing failed zones, the *MRMR* correctly describes the failure zones and reflects that failures should have occurred in areas that they did in fact occur.
- Both the *Q* and Bieniawski's *RMR* classification systems appear to be conservative in estimating stable stope spans.
- Results obtained from this investigation confirm the limitations of the

rock mass classification systems in estimating stable stope spans.

- ‘Doming’ is the only mode of failure that is not best described by the current *MRMR* system. The only system that does have some reliability in this mode of failure is the *Q* classification system, and this is on account of the fact that the dome surface usually has a thick clay infill and consequently a low strength.
- To enable the *MRMR* system to be successful in the assessment of dome failures, joint orientation adjustment has to be significantly lowered to produce realistic results in dome areas. The proposed reduction in the joint orientation adjustment cannot be applied to the majority of the rock mass as this would unrealistically reduce the rock mass strength. The distribution of the occurrence of doming is irregular and difficult to predict and consequently the proposed reduction in the joint condition adjustment cannot be practically applied as a predictive tool.

5.2 Analysis of stope panel stability using Laubscher’s (2001) *MRMR* system

The stability of an excavation can be estimated if the mining rock mass rating (*MRMR*) and excavation dimensions are known using the stability/instability graph. The stability/instability diagram had been developed and continuously updated by Laubscher for more than 20 years. The 1990 diagram was used for this study.

The stability index diagram plots the *MRMR* against the hydraulic radius of an excavation. The diagram is divided into the following three regions:

- caving zone;
- transition zone;
- stable zone (local support).

The *MRMR* system was originally developed using data from mines using block caving. Consequently the **caving zone** of the stability/instability diagram refers to situations where continued failure of the hangingwall

across the local support will occur, and the entire stope is affected. In shallow (less than 800 m) tabular mines such as Mine A, caving should not be allowed to occur. Failure of the back should be arrested by both local and regional support systems.

The **stable zone** of the stability diagram refers to areas where no fall of ground will occur. Spot bolting or systematic bolting on a wide (3 m) grid may be required. The area of overlap, the **transition zone**, refers to excavations in which in-stope falls of ground may occur, but the overall excavation is considered stable.

Figure 5-1 shows the Stability/Instability diagram, indicating plots of the *MRMR* against the hydraulic radius of several stopes at Mine A and Mine B. The observed stable and unstable areas (FOG's) were plotted separately so that the predicted behaviour can be compared with the observed rock mass behaviour.

5.2.1 Stability of stopes at Mine A

The observed stable areas, represented by the solid blue circles in Figure 5-1 plot within the stable zone of the graph. This illustrates that Laubscher's Stability/Instability graph accurately describes the rock mass behaviour in the stable regions of the mine.

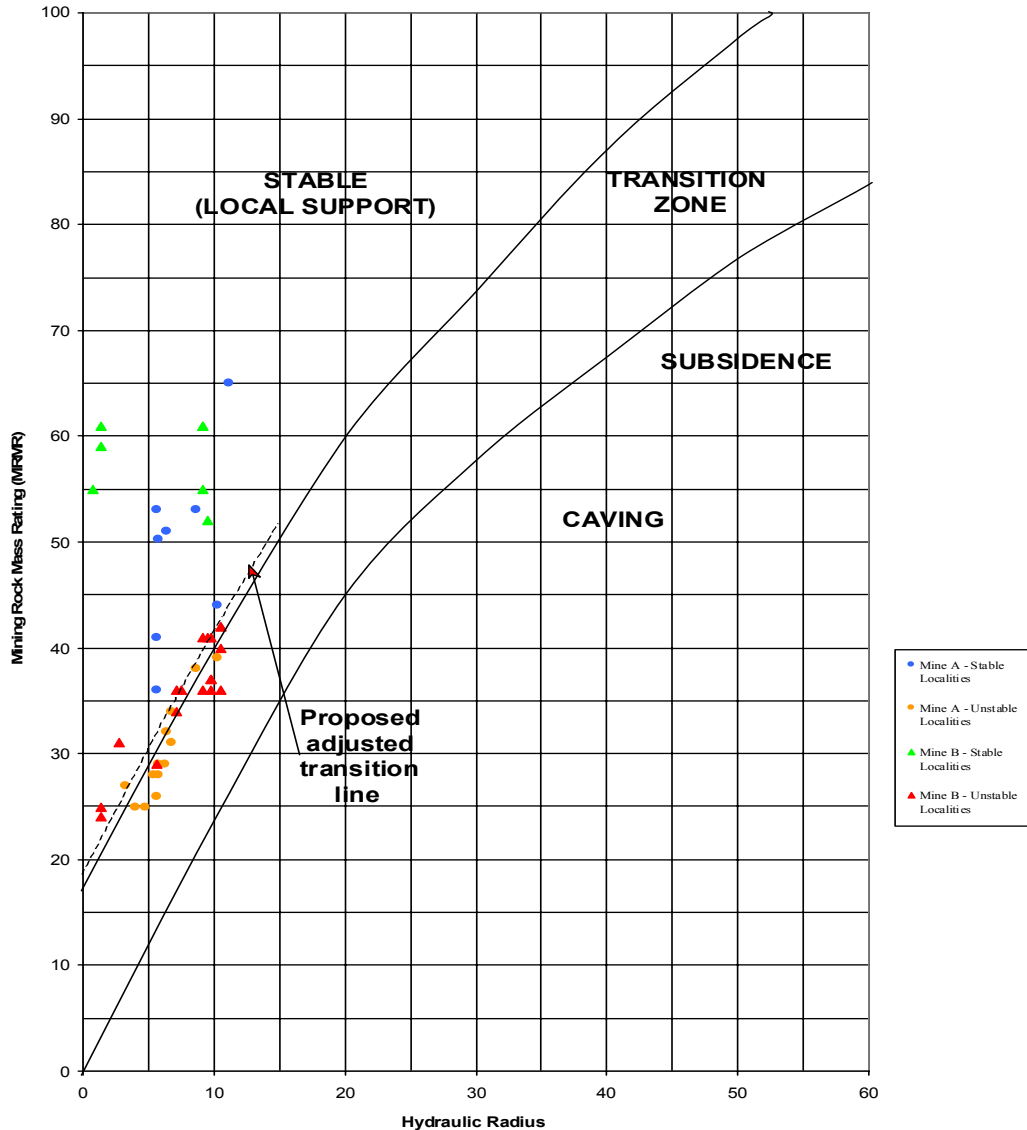

Figure 5.1 Stability diagram (after Laubscher 1990)

All of the observed unstable localities plot in a distinct cluster below the cluster of stable positions, and plots close to the upper boundary of the transition zone. More than 75% of the unstable localities, represented by the solid orange circles in Figure 5-1, plot within the transition zone. The remaining positions plot on or just above the upper transition zone boundary.

The conclusion can be made that the Stability/Instability diagram describes the observed rock mass behaviour in at Mine A with moderate reliability. However, a minor adjustment of the upper boundary of the transition zone

will increase the accuracy and reliability of the Stability/Instability diagram when dealing with stopes at that mine.

5.2.2 Stability of stopes at Mine B

The observed stable areas, represented by the solid green triangles in Figure 5-1, plot within the stable zone of the stability diagram. This illustrates that Laubscher's Stability/Instability diagram accurately describes the behaviour in the stable regions of the mine.

The unstable localities, represented by solid red triangles, plot in a distinct cluster that is significantly different to the stable excavation plots. The unstable localities plot close to the upper boundary of the transition zone, but only about 45% of these plot within the transition zone.

The conclusion can thus be made that the Stability/Instability diagram does highlight the difference in behaviour of stable and unstable ground at both mines, but it doesn't accurately predict the occurrence of FOG's. It is recommended that the upper boundary of the transition zone on the Stability/Instability diagram is adjusted as indicated in Figure 5-1 so that it more accurately describes the failed areas mapped at Mine A and B.

5.2.3 Influence of geological structures on stope stability

A closer inspection of the FOG localities at Mine A and B, reveals that the FOG's that are not accurately described by Laubscher's Stability diagram (with two exceptions), have the same failure mechanism. All of these FOG's are domes. The domes vary in scale from a few metres to a few 10's of metres. When undercutting a dome, the weight of the dome could exceed the strength of the joint surfaces, and result in dome failures. This is particularly likely in the shallow mining environment where the clamping stresses are normally low.

One of the major difficulties is designing stable stopes in dome areas, is the difficulty in predicting when you are likely to intersect a doming zone. It was found that the rock mass conditions within a dome area are very similar to the rock mass conditions in the remainder of the mine, with the exception of the orientation and infill of the dome surface. The spacing, orientation and condition of the other joint sets remain unchanged in the dome area. In addition, the majority of the domes do not fail if the standard in-stope support is adhered to.

The adjustments to the intact rock mass rating of dome areas are critical if the stability diagram is to be used effectively as a design tool. The joint orientation and mining induced stress adjustments should be significantly lower in dome areas. Thus, unless an area is identified as a dome area prior to the major excavation/mining, the adjustments applied will not reflect the actual condition and result in the stability of the excavation being over estimated. It is therefore recommended that detailed mapping of development excavations in any area of the mine is essential to determine the potential incidence of domes in the working stopes.

6 Proposed design methodology for stable stope spans

From the Literature review carried out (Section 2.4), it is concluded that the design of stable stope panels should be a **process** of defining the means of creating stable stope panels for the safety of underground workers and optimum extraction of the orebody. Therefore, a method is required whereby all rock properties, their variability, and an understanding of all rock mechanisms affecting the stability of stope spans are used as a fundamental base. A procedure for identifying the mechanisms and rock properties relevant to the specific problem is then required. In this way, existing knowledge should be used in an optimal way to design site specific stable stope spans.

Hence, it is proposed that the design methodology for stable stope panels is a process consisting of the following steps:

- Define objective.
- Rock mass characterisation.
- Estimation of *in situ* rock mass properties.
- Consider an “ideal” stope panel.
- Identification of potential failure modes.
- Stability analyses.
- Identification of significant hazards and assessment of significant risks.
- Geometric optimisation.
- Determination of support requirements.
- Design of support.
- Evaluation
- Recommendation and implementation
- Monitoring of excavation and support behaviour to validate design and permit modifications.

It is important to note that it is an iterative process with feedback loops that test/evaluate the design aspects such as:

- design assumptions / premise;
- design objectives / desired outcomes;
- the acceptability of the risk (i.e. are the significant risks tolerable.)

The design process is illustrated in Figure 6-1.

6.1 Rock mass characterisation

The roof or hangingwall of stope panels must be characterised in order to:

- define the rock mass condition;
- evaluate the rock mass strength and deformation behaviour;
- identify the most likely modes of potential rock mass failure;
- determine the most appropriate method of stability analysis or design;
- define geotechnical areas;
- define rock mass properties;
- evaluate the stability of the rock mass;
- evaluate the support requirements of the excavation.

The following steps are required to characterise the rock mass in the roof of stope panels:

- Collection of geotechnical data.
- Evaluation or estimation of the boundary conditions.
- Rock mass classification.
- Recording and presentation of geotechnical data.

These steps are discussed briefly in the following sections of the dissertation.

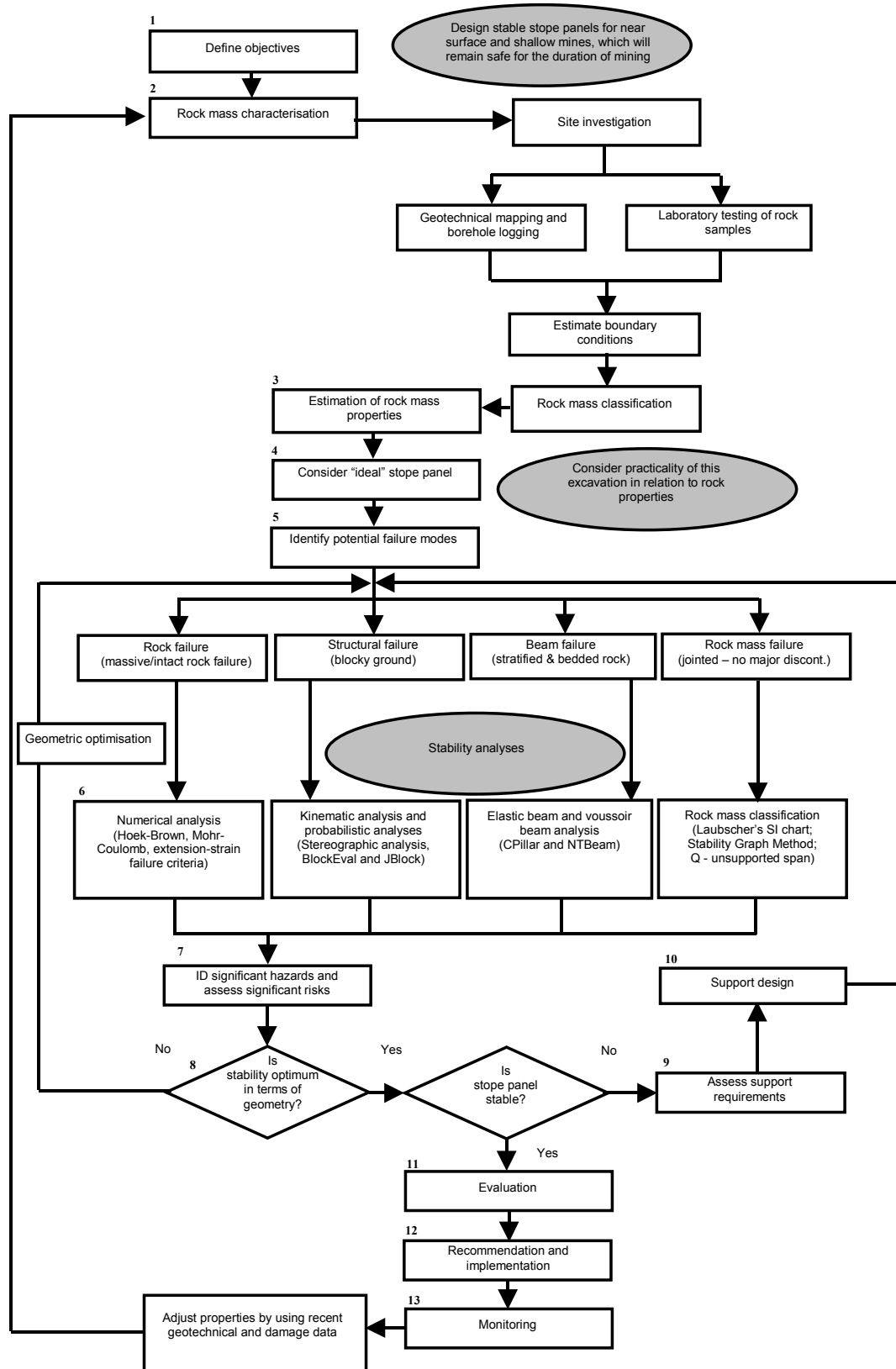

Figure 6-1 Proposed design methodology for stable stoppe panels

6.1.1 Collection of geotechnical data

The collection of sufficient and reliable geotechnical data forms the basis on which the rock mass will be characterised and is essential for the design of stable slope panels. This information represents the independent variables which cannot be controlled by the design engineer. **The source of potential geotechnical data and the extent of the existing geotechnical database depend on the stage of the investigation (pre-feasibility, feasibility preliminary design or final design stage).**

Geotechnical data should be obtained through:

- site investigations;
- geotechnical drilling and logging of borehole core;
- mapping of exposed rock surfaces;
- laboratory testing of rock samples.

Site investigations

The purpose of the initial site investigation is to establish the feasibility of the project. In essence, the initial site investigation involves the discovery, correlation, and analysis of such geological data as:

- rock types to be encountered;
- depth and character of overburden;
- major geological discontinuities such as faults and dykes;
- groundwater conditions and drainage;
- topography;
- potential problems, such as weak ground or swelling rock.

The following sources of information could be considered during the initial site investigation:

- geological maps;
- published literature;
- field mapping;

- exploration drilling;
- local knowledge;
- aerial and ground photographs of the area;
- geophysical techniques.

This information should then be used to carry out specific geotechnical drilling during the feasibility stage of the investigation. During the **preliminary design stage** of the study, the influence of geological structures, *in situ* and induced stresses, groundwater, quality and durability of the rock and rock mass should be evaluated and predicted. **Final designs** should be based on careful evaluation and optimisation drawing from a geotechnical database built up during the full duration of the study. This should include collection of data on rock failures.

Geotechnical drilling and logging of borehole core

The purpose of geotechnical drilling is to:

- confirm the geological interpretation;
- determine the quality and characteristics of the rock mass through geotechnical logging of the core;
- study groundwater conditions;
- provide cores for laboratory testing.

Mapping of exposed surfaces

The technique used to map exposed rock material should depend on the excavation behaviour. If the excavation behaviour is dictated by the joint orientations and other joint characteristics, specific mapping of the joint parameters will be required. One such technique is line mapping. If, however, the behaviour will be of a homogeneously jointed rock mass, then rock mass classification mapping will be appropriate. Window mapping is an example of rock mass classification mapping.

The following parameters and their variability for each joint set is required to determine the potential for the formation of blocks and wedges in the roof of stope panels:

- the mechanical properties of the rock material (uniaxial compressive strength, *UCS*, elastic modulus, *E*, Poisson's ratio, ν);
- the orientation (dip and dip direction using stereoplots);
- the joint spacing (including *RQD* data);
- the joint length;
- the condition of discontinuities (roughness, separation, weathering, continuity and infilling);
- groundwater conditions.

Knowledge of the mean, minimum and maximum values, and the statistical distributions for each of these parameters are required to provide a sufficient basis for deterministic and probabilistic analysis of stability.

Laboratory testing of rock samples

Real data on specific rock properties such as *UCS*, triaxial strength and shear strength obtained from laboratory testing of rock samples are required in order to characterise the rock mass accurately.

6.1.2 Evaluation or estimation of boundary conditions

In situ stresses determine the confinement imposed on the rock mass and is an essential boundary condition for the evaluation of stability. They can have the following effects on stability:

- instability may occur if the stress is low since rock blocks may have the freedom to fall out;
- the rock mass will be well confined and stable if the stress is higher;
- instability may occur due to rock fracturing if the stress level is sufficiently high.

Stress measurements using an overcoring technique, small flat jacks or hydrofracturing is expensive and time consuming. It is therefore suggested that *in situ* stress conditions be estimated based on the work carried out by Stacey *et al* (1998).

Appropriate numerical stress analyses should then be carried out applying the assumed *in situ* stress conditions to the proposed mining layout. The stresses in the hangingwall of the excavations should then be assessed in terms of potential failure mechanisms.

6.1.3 Rock mass classification

Rock mass classification can be used for the design of stable stope panels. In essence, rock mass classification relate practical experience gained on previous projects to the conditions anticipated at a proposed site. They are particularly useful in the planning and preliminary design stages of a rock engineering project but, in some cases, they also serve as the main practical basis for the design of complex underground structures.

To derive input properties for further analyses, data obtained from underground mapping, logging of borehole core and laboratory tests should be rated according to an appropriate rock mass classification system. It is suggested that at least two rock mass classification systems be used to obtain a picture of the rock mass fracturing, the characteristics of the fractures (planarity, roughness, infilling and continuity) and the location of major, continuous fault structures. The average and range of the rock mass classification values (e.g. *Q* and *RMR*) should be determined as a means of estimating the variability of the quality of each rock type.

6.1.4 Recording and presentation of geotechnical data

Geotechnical data collected must be recorded and presented such that it will be readily available and easily understood. This could include presentation of:

- borehole data in well-executed geotechnical logs;
- mapping data as spherical projections;
- relevant geological and geotechnical data for rock mass classification purposes;
- longitudinal sections and cross sections of structural geology;
- construction of a geotechnical domain model.

6.2 Estimation of rock mass properties

It is extremely important that the quality of input data matches the sophistication of the design methods. It is, however, almost impossible to perform controlled laboratory test on large, jointed rock samples. Therefore, estimates of the strength and stiffness properties are typically made by using rock mass classification in combination with laboratory determination of intact rock strength.

The following rock mass properties can be estimated from the rock mass classification data:

- Hoek and Brown m and s parameters;
- E .

The parameters m , s and E can be calculated from equations (40), (41), (42), (43) and (44).

6.3 Consider “ideal” excavation

The geometry of an “ideal” excavation is typically controlled by factors such as:

- drilling equipment;
- cleaning equipment;
- scheduling;
- full constraints;
- labour and equipment efficiencies;
- orebody dimensions.

6.4 Identification of potential failure modes

The following failure modes should be considered:

6.4.1 Structurally controlled, gravity driven failures

The following steps should be followed:

- evaluation of kinematically possible failure modes;
- assignment of shear strength to potential failure surfaces;
- calculation of factor of safety or risk of potential failures.

6.4.2 Stress induced, gravity assisted failures.

The following steps should be followed:

- Determination of *in situ* stress field in surrounding rock;
- assignment of rock mass properties;
- analysis of size of overstress zones around excavations.

6.5 Stability analyses

Appropriate analyses should be carried out to assess the stability of the “ideal” excavation. Wedge and block failure types could be analysed using analysis programs such as JBlock (Esterhuizen, 1994). Beam failure types should be analysed using the Voussoir beam analysis procedure proposed by Hutchinson *et al* (1996) or programs such as CPillar or NTBeam. Rock

mass stability should be assessed using rock mass classification systems as described in this dissertation.

6.6 Identification of significant hazards and assessment of significant risks

All significant hazards should be identified using an appropriate risk assessment methodology. Care must be taken to ensure that the hazards are identified systematically. Significant hazards / risks should then be eliminated or reduced to acceptable limits by optimising the geometry, installing support, etc. These aspects are discussed in the following sections.

6.7 Geometrical optimisation

If stability analyses show that the assumed “ideal” stope panel is unstable, or the support required to ensure stability is either unpractical or uneconomical, the “ideal” stope panel must be optimised by considering one or more of the following geometrical changes:

- Location

Relocation of stope panels should be considered not later than the reef development stage. At this stage, a stope panel can be placed in stronger and more stable rock for example by positioning pillars to coincide with major geological discontinuities.

- Orientation

Re-orientation of the stope panel should be considered with regards to the orientation of the:

- geological structure;
- *in situ* stress field.
- For maximum panel stability the following should be attempted:

- minimise the number and/or volume of potentially unstable roof wedges;
- do not have high stope panel walls parallel to major joint directions;
- do not plan panel orientations parallel to major joint directions;
- in inclined strata, mine in a direction perpendicular to bedding strike;
- under low stress conditions, mine in the direction of the minor principal stress, σ_3 .

- Shape

The shape of stope panels should be optimised with regards to the:

- geological structure;
- stress field.

As much use should be made of the natural stable shape which tends to result in a particular rock mass. Stress induced rock failure could be minimised by optimising the shape with respect to the stress field. If the rock is sufficiently strong, using an elliptical shape with its long axis in the direction of the maximum principal stress, σ_1 , could reduce the probability of stress induced rock failure. If, however, the stress to strength ratio is high (due to high field stresses or relatively weak rock), rock failure will occur. In this case, it is better to contain the failed rock by using an elliptical shape with its long axis parallel to the minimum principal stress, σ_3 , direction.

- Size

The stability of stope panels could be improved significantly by reducing the size or free span of the excavation. Reducing the size of a stope panel will not only reduce the number of structural weakness planes that will be exposed in the roof of the panel, but also the elastic deformation of the panel roof.

6.8 Evaluation of support requirements

Most “ideal” stope panels, even when optimised in terms of geometry, are inherently unstable and require support to improve the strength or capacity of the rock mass such that it will remain stable and safe, at least during extraction of the panel, and as long as access is required through the panel.

Appropriate support will depend on the risk associated with the excavation. Therefore, although the probability of rockfalls occurring could be high, the risk of rockfall accidents could be minimised by minimising entry to the stope panel.

At the same time, a database and damage maps should be developed identifying the location and mechanisms of failure in the mine. These failures should be back-analysed using appropriate failure models and criteria in order to prevent a reoccurrence.

Roof supports are used to help stabilise underground openings. Their performance characteristics must be properly matched to the loading environment and ground behaviour if they are to succeed.

The key characteristics of any support includes its maximum load carrying capacity, stiffness, and residual strength. Other important factors are timing of installation, the stability of the support as it is loaded, and the capability of the support system to provide skin control.

6.9 Evaluation of ideas and solutions

The solution proposed must now be interpreted and compared with the original objectives. This calls for a clear understanding of all pertinent interacting factors; that is, for the exercise of engineering judgement. If the evaluation shows up deficiencies or suggests more promising alternatives, loop back to the stability analysis stage.

6.10 Optimisation

Optimise the “ideal” opening with respect to location, orientation, shape and size. If any geometrical changes are made, loop back to Stage 4.

6.11 Conclusions and Recommendations

Provide a concise statement of the answer to the problem, point out the limitations or restrictions and indicate the direction to be followed in implementing the solution.

6.12 Monitoring

Monitor performance and take remedial measures in case of instability.

7 Conclusions and recommendations

7.1 Conclusions

The following general conclusions were drawn from this study:

- Not one mine in this study is using a proper engineering approach to stope panel and support design.
- Although most FOG incidents/accidents are associated by failure along geological structures, most mines do not use any design methodology based on structural analysis. In a few cases, complicated numerical analysis programs are used on an *ad hoc* basis to assess structurally controlled panel stability.
- In most cases, panel lengths are based on local experience and equipment requirements.
- Stope pillars are normally designed conservatively and the probability of regional instability, involving several stope panels, is unlikely.
- Valuable information regarding panel stability are often lost because FOG incidents are not investigated, recorded or back-analysed.
- Beam stability analyses are applicable to several mines and should be considered as one of the potential failure modes.
- There is a need for a systematic engineering approach to the design of stable stope panels.
- Rock mass classification forms an integral part of stope panel design. Although it cannot be used directly for stability analysis purposes, it should be used to estimate rock mass properties required for analytical designs.

7.1.1 Main objective

- Investigate the factors governing the stability of stope panels.
Factors affecting the stability of stope panels were summarised during the risk assessment part of the study. These factors are listed in the Fault Tree Analysis presented in Appendix E and in Section 4 of the dissertation.
- Define a suitable design methodology for near surface and shallow mining operations.
The proposed design methodology for stable stope panels is presented in Section 6.

7.1.2 Secondary objectives

Review relevant literature on stope panel and support design at shallow depth

Literature pertaining to stope panel and support design, and rock mass classification systems has been evaluated during the course of the research project and is presented in Section 2 of the dissertation. The focus has been on the identification of key aspects influencing the stability of stope spans, and the pros and cons of different design approaches.

Review and assess current rock mass classification systems

Current rock mass classification systems have been reviewed and assessed. A detailed discussion can be found in Sections 3. The following conclusions can be drawn from the review and assessment:

- The basic functions of rock mass classification systems are to:
 - subdivide the rock mass into zones of similar behaviour;
 - provide a basis for communication between various mining disciplines;
 - formulate design parameters for the actual mine design.
- Rock mass classifications are based on case histories and hence tend to perpetuate conservative practice.

- Most rock mass classification systems reviewed were oriented towards the prediction of support requirements for tunnels and permanent structures.
- Rock mass classification is not a rigorous analysis method.
- Rock mass classifications represent only one type of the design methods, an empirical one, which needs to be used in conjunction with other design methods.
- Not one of the rock mass classification systems give realistic support recommendations for most of stope panels found in shallow hard rock underground mines.
- Rock mass classifications should be used during the entire stage of a mine's life as an integral part of the design process.
- The reliability of the main classification systems is questionable under certain conditions (Pells, 2000). The reason for this is that, although the main classification systems consider similar parameters in calculating the final rock mass ratings, different systems apply different weighting to similar parameters and some include distinct parameters that influence the final rock mass quality rating. It is therefore important that:
 - at least two rock mass classification systems be used when classifying rock;
 - rock mass classification systems be used within the bounds of the case histories from which they were developed.
- Bieniawski's *RMR* places greater emphasis on the spacing of structural features in the rock mass, but does not take the induced rock stress into account. The *Q*-system, does not consider joint orientation, and only considers the joint condition (alteration and infill) of the most unfavourable joints. Therefore, the *Q*-system assumes that the rock mass strength is dominated by the strength of the weakest joint. Both of

these classification systems suggest that the orientation and inclination of the discontinuities are not as significant as one would normally assume, and that a differentiation between favourable and unfavourable are adequate for practical purposes. This assumption is not necessarily true for all engineering applications. In the case of mining, the orientations of the discontinuities have a significant influence on the stability of the excavation.

- The *MRMR* system has adjustments for both the orientations of discontinuities and the influence of mining induced stresses in the rock mass. These two adjustments result in the *MRMR* classification system being well suited to a mining environment.
- When dealing with extremely weak ground, both the *MRMR* and Bieniawski's *RMR* classification systems are difficult to apply. This is largely because both were developed for the hard rock environment. In the case of squeezing, swelling or flowing ground, the use of the *Q*-system may be more applicable.
- *RMR* may over rate the strength of a rock mass, which has moderately spaced joints but the joint themselves have a very low strength. The exclusion of a stress reduction factor from this classification system severely limits the application of the system to the mining environment where the stress environment changes as mining proceeds.
- Care should be taken not to:
 - average numbers obtained from field measurements across geotechnical domains;
 - lose sight of the characteristics and behaviour of the rock mass;
 - not to express individual parameters as single values, but rather as a distribution;
- Jointing can have a major effect on the behaviour of the rock mass. Deformation and failure will take place preferentially along the joints.

Often, one or two of the joint sets are dominant, and the implications are that both rock mass deformation and rock mass failure will be directional. This is not taken into account in the main rock mass classification approaches, which applies more to homogeneous rock mass behaviour.

- It is unlikely that there will ever be a universal rock mass classification system that will be able to cater for all the possible situations found in shallow hard rock underground mines. It is therefore suggested that the most appropriate rock mass classification systems be used, and if necessary, be modified to suit local conditions.
- When using rock mass classifications, the following procedure should be followed:
 - review the original published documents prior to the utilisation of a particular design chart or graph;
 - understand the original objectives associated with the design charts or graphs;
 - assess the applicability of the design chart or graph to the design needs;
 - if none of the available rock mass classification systems are applicable, develop a new empirical relationship based on actual data;
 - expand existing database as mining progresses to allow for further calibration of design charts or graphs.
- The stability of stope panels can be evaluated by considering one of the following approaches:
 - use Hutchinson and Diederichs's (1996) graph (Figure 2-3) illustrating the relationship between maximum unsupported span and Q value;
 - use Laubscher's Stability Graph (Figure 2-4) which correlates the adjusted *MRMR* with the hydraulic radius;

- use Potvin's Modified Stability Graph method (Figure 2-5), illustrating the relationship between the Modified Stability Number, N' , and hydraulic radius.

Visit selected mines (tabular and massive) to obtain information on panel collapses, and to assess the influence of support systems and the applicability of rock mass classification systems

Nine mines with different orebody geometries (tabular, massive and pipe) were identified and visited during the second part of this study. The aim was to visit stable and unstable stopes under different geotechnical conditions and to assess the influence of factors governing the stability of stope panels. The opinions of mine rock mechanics personnel on the design of stope panels under different geotechnical conditions were also elicited during the mine visits. A questionnaire was used in the process.

A review of research carried out by Joughin *et al* (1998) showed that shallow mines with tabular orebodies, in particular chrome mines, have a relatively high risk of rock fall accidents. It was therefore decided to pay special attention to the stability of panels found in chrome mines. Detailed mapping and borehole core logging were carried out in order to classify the rock mass according to three different rock mass classification systems. The rock mass classification data in turn were used to estimate rock mass properties that cannot be obtained from laboratory testing.

Data collection from the mines is described in Section 3 of the dissertation.

Identify hazards and assess the risks associated with instability of stope spans, and define procedure for definition of geotechnical areas

Information obtained from SAMRASS records, the literature survey carried out, and the information obtained during visits to selected mines were used to identify significant hazards and assess the significant risks relevant to the stability of stope panels. The risk assessment part of the study is discussed in Section 4 of the dissertation.

Analyse data obtained from mines and appropriate case histories of hangingwall collapses and determine the influence of different parameters

Examples of empirical and analytical design methods are discussed in Section 5 of the dissertation. Different rock mass classifications are used to assess and back-analyse the stability of some stope panels visited during the data collection stage of the project. Beam and wedge analysis programs are also used to assess the stability of structurally controlled stope panels.

Determine a procedure for the design of stope panel spans and support system requirements to ensure stable spans for different geotechnical areas

The proposed design methodology for stable stope panels is presented in Section 6. This methodology takes into account the special nature of rock as an engineering material and incorporates the current knowledge base. It provides procedural guidance for the design of stope spans subject to all potential failure mechanisms.

The design methodology consists of the following main components:

- rock mass characterisation;
- estimation of *in situ* rock mass properties;
- identification of potential failure modes;
- stability analyses;
- geometric optimisation;
- determination of support requirements;
- support design;
- evaluation of design;
- monitoring.

7.2 Recommendations

- More than one rock mass classification method and analytical design approach should be used to assess ground conditions and to carry out stability analyses.
- A systematic design approach should be followed to design stable stope panels.
- Analytical methods and failure criteria that can model the anticipated or identified failure mechanism and mode of failure most accurately should be used.
- All failure modes should be considered during stope panel design. This also applies to FOG investigations where hangingwall failures are often described in terms of “blocky” and “weak” only. Beam failure modes (buckling, shear and crushing failure) should be included.
- The Voussoir beam analysis technique has been used successfully in other countries and should be considered for stope panel designs in stratified rock.
- The proposed design methodology should be used during all stages of the mining process, from pre-feasibility to final design and implementation, and when compiling codes of practice to combat rockfall accidents.

8 References

- Anon, 1996. Guideline for the Compilation of a Mandatory Code of Practice to Combat Rockfall and Rockburst Accidents in Metalliferous Mines and Mines other than Coal. GME 7/4/118-AB1, Department of Minerals and Energy, Pretoria.
- Barton, N., Lien, R. and Lunde, J. 1974. Engineering classification of rock masses for the design of tunnel support, *Rock Mech.*, Vol. 6, No. 4, pp 189-236.
- Barton, N., Loset, F., Lien, R. and Lunde, J. 1980. Application of the Q-System in design decisions concerning dimensions and appropriate support for underground installations, *Rockstore, Int. Conf. on Sub-surface Space*, Stockholm, Vol. 2, pp. 553-561.
- Barton, N, and Bandis, S.C. 1990. Review of predictive capabilities of JRC-JCS model in engineering practice. *Proc. Int. Symp. On Rock Joints*, Leon Norway, (eds N. Barton and O Stephansson), 603-610. Rotterdam: A.A Balkema.
- Barton, N.R. and Choubey, V. 1977. The shear strength of rock joints in theory and practice. *Rock Mech.*, Vol. 10, (1 – 2), pp. 1-54.
- Bawden, W.F. 1993. The use of rock mechanics principles in canadian underground hard rock mine design. *Comprehensive Rock Engineering: Principles, Practice and Projects*, (ed. Hudson), Oxford: Pergamon Press, Vol. 5, pp. 247-290.
- Beer, G. and Meek, J.L. 1982. Design curves for roofs and hangingwalls in bedded rock based on 'voussoir' beam and plate solutions. *Trans. Instn Min. Metall. (Sect. A: Min. industry)* (pp A18 – A22).
- Bieniawski, Z.T. 1973. Engineering Classification of Jointed Rock Masses. *Trans S. Afr. Inst. Civ. Engrs* 15, pp. 335-344.
- Bieniawski, Z.T. 1976. Rock mass classification in rock engineering, *Proc. Symp. On Exploration for Rock Engineering*, Johannesburg, Vol. 1, A.A. Balkema, pp. 97-106.

- Bieniawski, Z.T. 1978. Determining rock mass deformability – experience from case histories, *Int. J. Rock Mech. Min. Sci.*, Vol. 15, pp. 237-247.
- Bieniawski, Z.T. 1984. *Rock Mechanics Design in Mining and Tunnelling*, Balkema, Rotterdam, p. 272.
- Bieniawski, Z.T. 1989. *Engineering Rock Mass Classifications*. John Wiley and Sons, Inc., New York.
- Bieniawski, Z.T. 1993. Classification of rock masses for engineering: The RMR system and future trends. *Comprehensive Rock Engineering*, (ed. Hudson), Oxford: Pergamon, Vol. 3, pp. 553-573.
- Brady, B.H.G. and Brown, E.T. 1993. *Rock Mechanics for Underground Mining*, second edition. London: Chapman & Hall. 571p.
- Brown, E.T. 1985. From theory to practice in rock engineering. *Trans. Institution of Mining and Metallurgy*, London, Vol. 94, pp. A67-A83.
- Coffey and Partners Pty Ltd. 1990. Bernalong Point Parking Station, *Rock Mechanics Studies*, Report No. S8009/2-AV, July.
- Cummings, R.A., Kendorski, F.S. and Bieniawski, Z.T. 1982. Caving rock mass classification and support estimation. U.S. Bureau of Mines Contract Report #J0100103. Chicago: Engineers International Inc.
- Curran, J.H., Corkum, B.T. and Pashutinski, I. 1996. CPillar 3D analysis of crown pillar and roof stability – User's guide Version 3.0, Rock Engineering Group, University of Toronto.
- Daehnke, A., Anderson, L.M., De Beer, D., Esterhuizen, G.S., et al 1998. Stope face support systems. SIMRAC Report GAP 330. Pretoria: Department of Minerals and Energy
- Deere, D.U., Hendron, A.J., Patton, F.D. and Cording, E.J. 1967. Design of surface and near surface construction in rock. In *Failure and breakage of rock*, proc. 8th U.S. symp. rock mech., (ed. C. Fairhurst), 237-302. New York: Soc. Min. Engrs, Am. Inst. Min. Metall. Petrolm Engrs.

- Diederichs, M.S. and Kaiser, P.K. 1999. Stability of large excavations in laminated hard rock masses: the voussoir analogue revisited. *Int. J. of Rock Mech. and Mining Sciences*. Vol. 36, pp. 97-117.
- Esterhuizen, G.S. 1996. *JBlock User's Manual and Technical Reference*, Pretoria.
- Esterhuizen, G.S. and Ackermann, K.A. 1998. Stochastic keyblock analysis for stope support design. *Int. J. of Rock Mech. & Min. Sci.* Vol. 35 Nos 4-5, Paper No. 122.
- Esterhuizen, G.S. and Streuders, S.B. 1998. Rockfall hazard evaluation using probabilistic keyblock analysis. *SARES97 proceedings*, pp. 452-458.
- Evans, W.H. 1941. The strength of undermined strata. *Institute of Mining and Metallurgy*. pp. 475-532.
- Fairhurst, C. and Cook, N.G.W. 1966. The phenomenon of rock splitting parallel to a free face under compressive stress. *Proc. Aus. Inst. Metall. Conf.*, Melbourne, pp. 337-349.
- Goel, R.K., Jethwa, J.L. and Paithankar, A.G. 1996. Correlation between Barton's Q and Bieniawski's RMR – A new approach. *Int. J. Rock Mech. Min. Sci. & Geomech.* Vol. 33, No. 2, pp. 179-181.
- Goodman, R.E. and Shi, G. 1965. *Block theory and its application to rock engineering*, Prentice Hall.
- Grimstad, E. and Barton, N. 1993. Updating the Q-System for NMT. *Proc. int. symp. on sprayed concrete - modern use of wet mix sprayed concrete for underground support, Fagernes*, (eds Kompen, Opsahl and Berg). Oslo: Norwegian Concrete Assn.
- Güler, G, Quaye, G.B., Jager, A.J., Schweitzer, J.K., Grodner, M, Reddy, N, Andersen, L, Milev, A and Wallmach, T. 1998. A methodology for the definition of geotechnical areas within the South African gold and platinum stoping horizons. *SIMRAC Project Report GAP 416*. SIMRAC: Johannesburg.

- Gürtunca, R.G. 1997. Identification of safety and health hazards and quantification of risks in the South African mining industry with time. SIMRAC Report SIMRISK 401. Pretoria: Department of Minerals and Energy.
- Harr, M.E. 1987. Reliability-based design in Civil Engineering. New York: McGraw-Hill
- Hoek, E. 1998. Rock Engineering Course Notes. <http://www.rocscience.com/hoek-corner.htm>
- Hoek, E. and Brown, E.T. 1988. The Hoek-Brown failure criterion - a 1988 update. Rock Engineering for Underground Excavations, Proc. 15th Canadian Rock Mech. Symp., (ed. J.C. Curran), 31-38. Toronto: Dept. of Civil Engineering, University of Toronto.
- Hoek, E. and Brown, E.T. 1980. Underground Excavations in Rock. Institution of Mining and Metallurgy, London. p. 527.
- Hoek, E. 1990. Estimating Mohr-Coulomb friction and cohesion values from the Hoek-Brown failure criterion. Technical Note, Int. J. Rock Mech. Min. Sci. & Geomech. Abstr., Vol. 27, No. 3, pp. 227-229.
- Hoek, E, Kaiser, P.K. and Bawden, W.F. 1995. Support of Underground Excavations in Hard Rock. A.A. Balkema, Rotterdam.
- Houghton, D.A. and Stacey, T.R. 1980. Application of probability techniques to underground situations, Proc. 7th Regional Conf. for Africa on Soil Mech. and Foundation Engineering, Accra, Vol. 2, A.A. Balkema, pp. 879-883.
- Hutchinson, J.D. and Diederichs, M.S. 1996. Cablebolting in Underground Mines, BiTech Publishers Ltd, Richmond, Canada, 401p.
- Itasca Consulting Group, Inc. 1991. UDEC Universal Distinct Element Code, Version 1.7 Volume 1.
- Jager, A.J. 1997. Current and future risks and causal issues relating to rock engineering on base metal, diamond and open cast mines in South Africa, SIMRAC Project No. SIMRISK 401. Pretoria: Department of Minerals and Energy.

- Jaeger, J.C. and Cook, N.G.W. 1979. Fundamentals of Rock Mechanics. Third edition. London, Chapman & Hall.
- Jeremic, M.L. 1987. Ground Mechanics in Hard Rock Mining. A.A. Balkema, Rotterdam.
- Joughin, W.C., Swart, A.H. and Stacey, T.R. 1998. Review of fall of ground problems in underground diamond mines and other mines with massive orebodies and make recommendations on research needs to reduce fall of ground casualties, particularly in the face area. SIMRAC Report OTH 411. Pretoria: Department of Minerals and Energy.
- Kendorski, F., Cummings, R., Bieniawski, Z.T. and Skinner, E. 1983. Rock mass classification for block caving mine drift support. Proc. 5th Congr. Int. Soc. Rock Mech., Melbourne, B51-B63. Rotterdam: Balkema.
- Kirsten, H.A.D. 1994. Review of norms for probability of failure and risk in engineering design. Unpublished.
- Laubscher, D.H. 1977. Geomechanics classification of jointed rock masses - mining applications. Trans. Instn. Min. Metall. Vol. 86, pp. A 1-8.
- Laubscher, D.H. 1984. Design aspects and effectiveness of support systems in different mining conditions. Trans. Inst. Min. Metall., Vol. 93, pp A70-A82.
- Laubscher, D. H. 1990. A Geomechanics Classification System for the Rating of Rock Mass in Mine Design. J. S. Afr. Inst. Min. Metall., Vol. 90, No. 10, pp. 257-273.
- Laubscher, D.H. 1993. Planning mass mining operations. Comprehensive Rock Engineering: Principles, Practice and Projects, (ed. Hudson), Oxford: Pergamon Press, Vol. 2, pp. 547-583.
- Laubscher, D.H. 2001. Cave mining – state of the art, Chapter 55 in Underground Mining Methods, ed. Hustrulid and Bullock, SME, pp. 455-463.

- Laubscher, D.H. and Page, C.H. 1990. The design of rock support in high stress or weak rock environments. Proc. 92nd Can. Inst. min. Metall. AAGM, Ottawa, Paper #91.86, A 1-8.
- Laubscher, D. H. and Taylor, H.W. 1976. The importance of geomechanics classification of jointed rock masses in mining operations, Proc. Symp. Exploration for Rock Engineering, Johannesburg, Vol. 1, A.A. Balkema, pp 119-128.
- Lauffer, H. 1958. Gebirgsklassifizierung für den Stollenbau. Geol. Bauwesen 24(1), 46-51.
- Mathews, K.E., Hoek, E., Wyllie, D.C. and Stewart, S.B.V. 1981. Prediction of stable excavation for mining at depth below 1000 m in hard rock. CANMET Report. DSS Serial No. OSQ80-00081, DSS File No. 17SQ.23440-0-9020. Ottawa: Dept. Energy, Mines and Resources.
- Merritt, A.H. 1972. Geological Prediction for Underground Excavations. Proc. Rapid Excav. Tunnelling Conf. AIME, New York, pp. 115-132
- Nickson, S.D. 1992. Cable Support Guidelines for Underground Hard Rock Mine Operations. Unpublished MAsc. Thesis, Dept. Mining and Mineral Processing, University of British Columbia, 223p.
- Patton, F.D. 1966. Multiple modes of shear failure in rock. Proc. 1st Congr. Int. Soc. Rock Mech., Lisbon 1, 509-513.
- Pacher, F. Rabcewicz, L. and Golser, J. 1974. Zum der seitigen Stand der Gebirgsklassifizierung in Stollen-und Tunnelbau. Proc. XXII Geomech. Colloq. Salzburg, 51-58.
- Palmström 1982. The volumetric joint count – A useful and simple measure of the degree of rock jointing. Proc. 4th Congr. Int. Assn. Engng. Geol., Delhi 5, pp. 221-228.
- Palmström, A. 1985. Application of the volumetric joint count as a measure of rock mass jointing. Proc. Int. Symp. On Fundamentals of Rock Joints, Björkliden, pp. 103-111.
- Peck, R.B. 1969. The observational method in applied soil mechanics – 9th Rankine Lecture, Geotechnique, Vol. 19, pp. 171-187.

- Pells, P.J.N., Best, R.J. and Poulos, H.G. 1994. Design of roof support of the Sydney Opera House underground parking station. *Tunnelling and Underground Space Technology*. Vol. 9, No. 2, pp. 201-207. (Elsevier Science Ltd.)
- Pells, P.J.N., Poulos, H.G. and Best, R.J. 1991. Rock reinforcement design for a shallow large-span cavern. *Proceedings, VIIIth International Congress on Rock Mechanics, Aachen, Germany*, 1193 – 1198. Rotterdam: A.A. Balkema.
- Pine, R.J., Lay, S. Randall, M.M. and Trueman, R. 1992. Rock engineering design development at South Crofty mine. *Trans. Instn. Min. Metall.* (Sect. A: Min. industry), pp A13-A22.
- Potvin, Y. 1988. Empirical open stope design in Canada. Ph. D. thesis, Dept. Mining and Mineral Processing, University of British Columbia.
- Potvin, Y. and Milne, D. 1992. Empirical cable bolt support design. In *Rock Support, Sudbury*, (eds P.K. Kaiser and D.R. McCreath), 269-275. Rotterdam: Balkema
- Poulos, H.G. 1989. Program PIES Axial Response of Piles in Expansive Soils. Centre for Geotechnical Research, University of Sydney.
- Ritter, W. 1879. *Die Statik der Tunnelgebölbe*. Berlin: Springer.
- Serafim, J.L. and Pereira, J.P. 1983. Consideration of the geomechanical classification of Bieniawski. *Proc. Int. Symp. on Engineering Geology and Underground Construction, Lisbon, Portugal*, Vol. 1, pp II.33-II.42.
- Stacey, T.R. 1981. A simple extension strain criterion for fracture of brittle rock, *Int. J. Rock Mech. Min. Sci. and Geomech. Abstr.*, Vol. 18, pp. 469-474.
- Stacey, T.R. and Page, C.H. 1986. *Practical Handbook for Underground Rock Mechanics*. Clausthal-Zellerfeld: Trans Tech Publications, 144p.
- Stacey, T.R. and Wesseloo, J. 1998. Evaluation and upgrading of records of stress measurement data in the mining industry. SIMRAC Report GAP 511. Pretoria: Department of Minerals and Energy.

- Stewart, S.B.V. and Forsyth, W.W. 1995. The Mathews method for open stope design, CIM Bulletin, 88(992), pp. 45-53
- Stini, I. 1950. Tunnulbaueologie, Springer-Verlag, Vienna, 336 p.
- Terzaghi, K. 1946. Rock defects and loads on tunnel support. Rock Tunnelling with Steel Supports, ed. R.V. Proctor and T.L. White, Commercial Shearing and Stamping Company, Youngstown, OH, pp. 15-99.
- Van Scalkwyk, A. 1999. Rock slope engineering. Evening lecture series. SAICE Geotechnical Division in collaboration with SAEG. 26 May 1999.
- Watson, B.P. and Noble, K.R. 1997. Comparison between geotechnical areas on the Bushveld Complex platinum mines, to identify critical spans and suitable in-panel support. SARES 97 proceedings, pp. 440-451.
- Wickham, G.E., Tiedemann, H.R. and Skinner, E.H. 1972. Support determination based on geologic predictions. In Proc. North American rapid excav. tunnelling conf., Chicago, (eds K.S. Lane and L.A. Garfield), 43-64. New York: Soc. Min. Engrs, Am. Inst. Min. Metall. Petrolm Engrs.
- Wilde, D.J. 1978. Globally optimal design. Wiley Interscience, New York. NY, 1288pp.
- York, G., Canbulat, I., Kabeya, K.K., Le Bron, K., Watson, B.P. and Williams, S.B. 1998. Final project report entitled: Develop guidelines for the design of pillar systems for shallow and intermediate depth, tabular, hard rock mines and provide a methodology for assessing hangingwall stability and support requirements for the panels between pillars. GAP 334 SIMRAC Report GAP 334. Pretoria: Department of Minerals and Energy.

7 Conclusions and recommendations

7.1 Conclusions

The following general conclusions were drawn from this study:

- Not one mine in this study is using a proper engineering approach to stope panel and support design.
- Although most FOG incidents/accidents are associated by failure along geological structures, most mines do not use any design methodology based on structural analysis. In a few cases, complicated numerical analysis programs are used on an *ad hoc* basis to assess structurally controlled panel stability.
- In most cases, panel lengths are based on local experience and equipment requirements.
- Stope pillars are normally designed conservatively and the probability of regional instability, involving several stope panels, is unlikely.
- Valuable information regarding panel stability are often lost because FOG incidents are not investigated, recorded or back-analysed.
- Beam stability analyses are applicable to several mines and should be considered as one of the potential failure modes.
- There is a need for a systematic engineering approach to the design of stable stope panels.
- Rock mass classification forms an integral part of stope panel design. Although it cannot be used directly for stability analysis purposes, it should be used to estimate rock mass properties required for analytical designs.

7.1.1 Main objective

- Investigate the factors governing the stability of stope panels.
Factors affecting the stability of stope panels were summarised during the risk assessment part of the study. These factors are listed in the Fault Tree Analysis presented in Appendix E and in Section 4 of the dissertation.
- Define a suitable design methodology for near surface and shallow mining operations.
The proposed design methodology for stable stope panels is presented in Section 6.

7.1.2 Secondary objectives

Review relevant literature on stope panel and support design at shallow depth

Literature pertaining to stope panel and support design, and rock mass classification systems has been evaluated during the course of the research project and is presented in Section 2 of the dissertation. The focus has been on the identification of key aspects influencing the stability of stope spans, and the pros and cons of different design approaches.

Review and assess current rock mass classification systems

Current rock mass classification systems have been reviewed and assessed. A detailed discussion can be found in Sections 3. The following conclusions can be drawn from the review and assessment:

- The basic functions of rock mass classification systems are to:
 - subdivide the rock mass into zones of similar behaviour;
 - provide a basis for communication between various mining disciplines;
 - formulate design parameters for the actual mine design.
- Rock mass classifications are based on case histories and hence tend to perpetuate conservative practice.

- Most rock mass classification systems reviewed were oriented towards the prediction of support requirements for tunnels and permanent structures.
- Rock mass classification is not a rigorous analysis method.
- Rock mass classifications represent only one type of the design methods, an empirical one, which needs to be used in conjunction with other design methods.
- Not one of the rock mass classification systems give realistic support recommendations for most of stope panels found in shallow hard rock underground mines.
- Rock mass classifications should be used during the entire stage of a mine's life as an integral part of the design process.
- The reliability of the main classification systems is questionable under certain conditions (Pells, 2000). The reason for this is that, although the main classification systems consider similar parameters in calculating the final rock mass ratings, different systems apply different weighting to similar parameters and some include distinct parameters that influence the final rock mass quality rating. It is therefore important that:
 - at least two rock mass classification systems be used when classifying rock;
 - rock mass classification systems be used within the bounds of the case histories from which they were developed.
- Bieniawski's *RMR* places greater emphasis on the spacing of structural features in the rock mass, but does not take the induced rock stress into account. The *Q*-system, does not consider joint orientation, and only considers the joint condition (alteration and infill) of the most unfavourable joints. Therefore, the *Q*-system assumes that the rock mass strength is dominated by the strength of the weakest joint. Both of

these classification systems suggest that the orientation and inclination of the discontinuities are not as significant as one would normally assume, and that a differentiation between favourable and unfavourable are adequate for practical purposes. This assumption is not necessarily true for all engineering applications. In the case of mining, the orientations of the discontinuities have a significant influence on the stability of the excavation.

- The *MRMR* system has adjustments for both the orientations of discontinuities and the influence of mining induced stresses in the rock mass. These two adjustments result in the *MRMR* classification system being well suited to a mining environment.
- When dealing with extremely weak ground, both the *MRMR* and Bieniawski's *RMR* classification systems are difficult to apply. This is largely because both were developed for the hard rock environment. In the case of squeezing, swelling or flowing ground, the use of the *Q*-system may be more applicable.
- *RMR* may over rate the strength of a rock mass, which has moderately spaced joints but the joint themselves have a very low strength. The exclusion of a stress reduction factor from this classification system severely limits the application of the system to the mining environment where the stress environment changes as mining proceeds.
- Care should be taken not to:
 - average numbers obtained from field measurements across geotechnical domains;
 - lose sight of the characteristics and behaviour of the rock mass;
 - not to express individual parameters as single values, but rather as a distribution;
- Jointing can have a major effect on the behaviour of the rock mass. Deformation and failure will take place preferentially along the joints.

Often, one or two of the joint sets are dominant, and the implications are that both rock mass deformation and rock mass failure will be directional. This is not taken into account in the main rock mass classification approaches, which applies more to homogeneous rock mass behaviour.

- It is unlikely that there will ever be a universal rock mass classification system that will be able to cater for all the possible situations found in shallow hard rock underground mines. It is therefore suggested that the most appropriate rock mass classification systems be used, and if necessary, be modified to suit local conditions.
- When using rock mass classifications, the following procedure should be followed:
 - review the original published documents prior to the utilisation of a particular design chart or graph;
 - understand the original objectives associated with the design charts or graphs;
 - assess the applicability of the design chart or graph to the design needs;
 - if none of the available rock mass classification systems are applicable, develop a new empirical relationship based on actual data;
 - expand existing database as mining progresses to allow for further calibration of design charts or graphs.
- The stability of stope panels can be evaluated by considering one of the following approaches:
 - use Hutchinson and Diederichs's (1996) graph (Figure 2-3) illustrating the relationship between maximum unsupported span and Q value;
 - use Laubscher's Stability Graph (Figure 2-4) which correlates the adjusted *MRMR* with the hydraulic radius;

- use Potvin's Modified Stability Graph method (Figure 2-5), illustrating the relationship between the Modified Stability Number, N' , and hydraulic radius.

Visit selected mines (tabular and massive) to obtain information on panel collapses, and to assess the influence of support systems and the applicability of rock mass classification systems

Nine mines with different orebody geometries (tabular, massive and pipe) were identified and visited during the second part of this study. The aim was to visit stable and unstable stopes under different geotechnical conditions and to assess the influence of factors governing the stability of stope panels. The opinions of mine rock mechanics personnel on the design of stope panels under different geotechnical conditions were also elicited during the mine visits. A questionnaire was used in the process.

A review of research carried out by Joughin *et al* (1998) showed that shallow mines with tabular orebodies, in particular chrome mines, have a relatively high risk of rock fall accidents. It was therefore decided to pay special attention to the stability of panels found in chrome mines. Detailed mapping and borehole core logging were carried out in order to classify the rock mass according to three different rock mass classification systems. The rock mass classification data in turn were used to estimate rock mass properties that cannot be obtained from laboratory testing.

Data collection from the mines is described in Section 3 of the dissertation.

Identify hazards and assess the risks associated with instability of stope spans, and define procedure for definition of geotechnical areas

Information obtained from SAMRASS records, the literature survey carried out, and the information obtained during visits to selected mines were used to identify significant hazards and assess the significant risks relevant to the stability of stope panels. The risk assessment part of the study is discussed in Section 4 of the dissertation.

Analyse data obtained from mines and appropriate case histories of hangingwall collapses and determine the influence of different parameters

Examples of empirical and analytical design methods are discussed in Section 5 of the dissertation. Different rock mass classifications are used to assess and back-analyse the stability of some stope panels visited during the data collection stage of the project. Beam and wedge analysis programs are also used to assess the stability of structurally controlled stope panels.

Determine a procedure for the design of stope panel spans and support system requirements to ensure stable spans for different geotechnical areas

The proposed design methodology for stable stope panels is presented in Section 6. This methodology takes into account the special nature of rock as an engineering material and incorporates the current knowledge base. It provides procedural guidance for the design of stope spans subject to all potential failure mechanisms.

The design methodology consists of the following main components:

- rock mass characterisation;
- estimation of *in situ* rock mass properties;
- identification of potential failure modes;
- stability analyses;
- geometric optimisation;
- determination of support requirements;
- support design;
- evaluation of design;
- monitoring.

7.2 Recommendations

- More than one rock mass classification method and analytical design approach should be used to assess ground conditions and to carry out stability analyses.
- A systematic design approach should be followed to design stable stope panels.
- Analytical methods and failure criteria that can model the anticipated or identified failure mechanism and mode of failure most accurately should be used.
- All failure modes should be considered during stope panel design. This also applies to FOG investigations where hangingwall failures are often described in terms of “blocky” and “weak” only. Beam failure modes (buckling, shear and crushing failure) should be included.
- The Voussoir beam analysis technique has been used successfully in other countries and should be considered for stope panel designs in stratified rock.
- The proposed design methodology should be used during all stages of the mining process, from pre-feasibility to final design and implementation, and when compiling codes of practice to combat rockfall accidents.