

University of Pretoria etd – Morar, D (2005)

**The development of an interferon-gamma (IFN $\gamma$ ) assay for the  
diagnosis of tuberculosis in African elephants (*Loxodonta africana*)  
and black rhinoceros (*Diceros bicornis*)**

**Darshana Morar**

University of Pretoria etd – Morar, D (2005)

**The development of an interferon-gamma (IFN $\gamma$ ) assay for the  
diagnosis of tuberculosis in African elephants (*Loxodonta africana*)  
and black rhinoceros (*Diceros bicornis*)**

**BY**

**DARSHANA MORAR**

**Submitted in partial fulfilment of the requirements**

**for the degree of**

**Masters Scientiae (Veterinary Sciences)**

**in the**

**Department of Veterinary Tropical Diseases**

**Faculty of Veterinary Sciences**

**University of Pretoria**

**September 2003**

## TABLE OF CONTENTS

• Declaration	i
• Acknowledgements	ii
• Abstract	iii
• List of figures	v
• List of tables	vii
• List of abbreviations	viii

### Chapter 1 Literature Review

1.1	Introduction	1
1.2	Aetiology	2
1.3	Transmission	2
1.4	Survival and pathogenesis of <u>Mycobacterium bovis</u>	3
1.5	Epidemiology	5
1.6	Clinical signs, symptoms and pathological aspects	10
1.6.1	Clinical symptoms and pathological findings in elephants infected with <u>Mycobacterium tuberculosis</u>	12
1.6.2	Clinical symptoms and pathological findings in rhinoceros Affected by tuberculosis	12
1.6.3	Pathology in other animals infected with <u>Mycobacterium bovis</u>	12
1.7	Diagnostic approaches	15
1.7.1	Microbiology	15
1.7.2	Rapid DNA amplification procedures	16
1.7.3	DNA finger printing	16
1.7.4	Immunologically based diagnostic tests	16
1.7.5	Cytokine assays	21
1.7.6	Pachyderms and tuberculosis	24
1.8	Conclusion	26
1.9	Objectives of the thesis	27
1.10	Time Frame	27

### Chapter 2 Cloning of Rhinoceros and Elephant Interferon-gamma (IFN $\gamma$ )

2.1	Introduction	28
2.1.1	The GATEWAY Cloning Technique	28
2.2	Materials and Methods	32
2.2.1	PBMC Stimulation	32
2.2.2	mRNA isolation and cDNA synthesis	32
2.2.3	PCR for the Elephant cDNA	33
	Primers	
	Reaction mix	
	PCR cycles	
2.2.4	PCR for the Rhinoceros cDNA	34
	Primers	
	Reaction mix	
	PCR cycles	

2.2.5	GATEWAY PCR .....	35
	Elephant amplified cDNA	
	Rhinoceros amplified cDNA	
2.2.6	BP reaction .....	36
2.2.7	Transformation in DH5 $\alpha$ cells .....	36
2.2.8	Screening transformants .....	36
2.2.9	Plasmid extraction .....	37
2.2.10	LR reaction .....	37
2.3	Results.....	38
2.4	Discussion .....	46
Chapter 3	Expression and Purification of Rhinoceros and Elephant Interferon- gamma	
3.1	Introduction .....	50
3.2	Materials and Methods .....	51
3.2.1	Transformation into BL21DE codon+ cells .....	51
3.2.2	Small-scale induction of elephant IFN $\gamma$ and rhinoceros IFN $\gamma$ ..	52
3.2.3	Production and isolation of inclusion bodies .....	52
3.2.4	Preparation of the Ni <sup>2+</sup> matrix.....	53
3.2.5	Optimising Imidazole concentration required for optimal protein purification on the Ni <sup>2+</sup> .....	54
3.2.6	Optimising the volume of Ni <sup>2+</sup> matrix required for optimal protein purification .....	56
3.2.7	Purification and refolding of the protein on the Ni <sup>2+</sup> matrix .....	57
3.2.8	Dialysis and filtration of recombinant rhinoceros and elephant IFN $\gamma$ .....	58
3.2.9	SDS-PAGE Analysis .....	58
3.3	Results.....	60
3.4	Discussion .....	67
<b>Chapter 4</b>	<b>Production and Selection of Monoclonal Antibodies</b>	
4.1	Introduction .....	70
4.2	Materials and Methods .....	71
4.2.1	Immunization of BalbC/mice .....	71
4.2.2	Isolation of spleen cells .....	73
4.2.3	Fusion technique .....	73
4.2.4	Screening of hybridomas for antibody production .....	74
4.2.5	Western blot .....	75
4.2.6	Mouse-hybridoma sub-typing/ELISA .....	75
4.3	Results.....	76
4.4	Discussion .....	82
Chapter 5	Conclusions	
	<b>Concluding remarks .....</b>	<b>85</b>

## DECLARATION

**I declare that this dissertation is my own work. It has been submitted for the Degree Masters Scientiae (Veterinary Sciences) at the University of Pretoria, Pretoria. It has not been submitted before for any degree or examination in any other University.**

**I further declare that the work presented was approved by the Animal Use and Care Committee for research of both the University of Pretoria, South Africa and the University Utrecht, The Netherlands.**

---

**Signature of candidate**

**Day of**

**2003/09/15**

## ACKNOWLEDGEMENTS

I wish to acknowledge and express my sincere appreciation and gratitude to the following people:

**Anita Michel for** giving me the opportunity to work on this project.

**Estelle Venter** for her support, encouragement, patience and guidance.

**Peter Van Kooten** for his assistance during the production and screening of the monoclonal antibodies.

**Judith Hendriks, Corlinda Tenbrink, Erwin Claassens and Daphne Van Haarlem** for their assistance in the laboratory.

A special thanks to my supervisors **Victor Rutten** and **Edwin Tijhaar**, under whose supervision and guidance, I worked for a period of 13 months in The Netherlands at the Utrecht University. I thank you for your support, encouragement and friendship.

Thank you to all my colleagues at the Department of Immunology at the Utrecht University in The Netherlands, as well as at the Department of Veterinary Tropical Diseases at the University of Pretoria in South Africa for their support and encouragement.

## ABSTRACT

**The development of an interferon-gamma (IFN $\gamma$ ) assay for the diagnosis of tuberculosis caused by *Mycobacterium bovis* in African elephants (*Loxodonta africana*) and black rhinoceros (*Diceros bicornis*)**

*D.Morar*<sup>1</sup>, *E.Tijhaar*<sup>2</sup>, *AL Michel*<sup>3</sup>, *EH Venter*<sup>2</sup>, *V PMG Rutten*<sup>2</sup>

**Supervisor:** Prof Estelle Venter

**Co-Supervisors:** Dr.Edwin Tijhaar, Dr. Anita L. Michel, Dr. Victor PMG Rutten

**Department:** <sup>1</sup>Department of Veterinary Tropical Diseases, Faculty of Veterinary Sciences, University of Pretoria, South Africa.  
<sup>2</sup>Department of Immunology and Infectious Diseases, Faculty of Veterinary Medicine, Utrecht University, The Netherlands.  
<sup>3</sup>The TB Laboratory, Onderstepoort Veterinary Institute, Onderstepoort, South Africa.

**Degree:** Magister Scientiae (Veterinary Sciences)

The objective of this project was to design tools for a diagnostic test that will prove valuable in the detection of tuberculosis in elephants and rhinoceros by using the cytokine IFN $\gamma$  as an indicator of *Mycobacterium bovis* responsiveness.

Interferon-gamma (IFN $\gamma$ ), a type II interferon, is a cytokine mainly produced by Th1 and cytotoxic T-cells expressing surface markers CD4 and CD8, respectively and natural killer cells (Ibelgauts; 1999). In response to a mycobacterial infection antigen specific Th1- and cytotoxic T-cells are induced. When these cells encounter their specific mycobacterial antigen, they will respond by producing IFN $\gamma$ . Based on this principle a diagnostic test was developed. In this test PBMCs will be stimulated with

## University of Pretoria etd – Morar, D (2005)

*M.bovis* specific antigen and the subsequent production of IFN $\gamma$  by specific T-helper cells will be determined by IFN $\gamma$  of elephants and rhinoceros.

In order to develop such an assay recombinant elephant and rhinoceros IFN $\gamma$  was cloned, sequenced, expressed, purified and subsequently a monoclonal antibody against IFN $\gamma$  was produced. Monoclonal antibodies were selected by a number of ELISAs using recombinant IFN $\gamma$ . Preliminary results are promising and further tests are underway regarding the specificity and sensitivity of the assay before field trials can be performed.

The results of this study has significant implications in the design of an IFN $\gamma$  diagnostic kit for the diagnosis of tuberculosis, as caused by *M.bovis*, in elephants and rhinoceros as well as other wildlife affected by this debilitating disease.



## LIST OF FIGURES

- Figure 2.1** Bacteriophage lambda recombination in *E.coli*.
- Figure 2.2** Gateway BP reaction: recombination of a PCR fragment containing *attB* extensions with *attP* substrate (donor vector) results in an entry clone containing *attL* sequences.
- Figure 2.3** Gateway LR reaction: recombination of an *attL* substrate (entry clone) with an *attR* substrate (destination vector). Results in formation of an expression clone containing *attB* sequences.
- Figure 2.4** Schematic representation of pET15bGW vector.
- Figure 2.5** Analysis of PCR products on agarose gel (elephant IFN $\gamma$ ).
- Figure 2.6** Analysis of PCR products on agarose gel (rhinoceros IFN $\gamma$ ).
- Figure 2.7** Analysis of Gateway PCR results of the elephant IFN $\gamma$  samples on agarose gel.
- Figure 2.8** Analysis of the PCR results obtained from the Gateway PCR of the rhinoceros IFN $\gamma$  samples.
- Figure 2.9** Analysis of the colonies selected for the screening of pDONR containing the gene of interest (elephant IFN $\gamma$  + recombination sites).
- Figure 2.10** Analysis of the colonies selected for the screening of pDONR containing the gene of interest (rhinoceros IFN $\gamma$  + recombination sites).
- Figure 2.11** Analysis of elephant IFN $\gamma$  and rhinoceros IFN $\gamma$  clones screened after transformation into the pET15bGW vector.
- Figure 3.1** Flow diagram of the purification of proteins on the Nickel matrix.
- Figure 3.2** Analysis of the small-scale induction of the rhinoceros and elephant IFN $\gamma$  samples on SDS-PAGE.
- Figure 3.3** SDS-PAGE showing the results from the stage of total protein lysate until purification on the Ni<sup>2+</sup> matrix using different concentrations of Imidazole. (Rhinoceros IFN $\gamma$ ).

University of Pretoria etd – Morar, D (2005)

- Figure 3.4** SDS-PAGE showing the results from the stage of total protein lysate until purification on the Ni<sup>2+</sup> matrix using different concentrations of Imidazole. (Elephant IFN $\gamma$ ).
- Figure 3.5** SDS-PAGE analysis of protein (elephant IFN $\gamma$ ) after refolding on the Nickel matrix.
- Figure 3.6** SDS-PAGE analysis of protein (rhinoceros IFN $\gamma$ ) after refolding on the Nickel matrix.
- Figure 3.7** Recombinant rhinoceros IFN $\gamma$  after dialysis and filtration.
- Figure 3.8** Recombinant elephant IFN $\gamma$  after dialysis and filtration.
- Figure 4.1** Results of the responses to clone 8E7 to feline IFN $\gamma$ , dog TNF $\alpha$ , dog IFN $\gamma$ , elephant IFN $\gamma$  without the his-tag region and elephant IFN $\gamma$  with the his-tag construct.
- Figure 4.2** Western blot of recombinant elephant IFN $\gamma$  (construct without the his-tag region).
- Figure 4.3** Subtyping of the different clones, obtained during the screening of the hybridoma clones.

## LIST OF TABLES

- Table .1.1** Reservoir hosts of BTB throughout the world.
- Table 1.2** Prevalence of BTB in the Kruger National Park from 1991-1998.
- Table 1.3** Known occurrences of BTB in African free-ranging wildlife.
- Table 1.4** Clinical signs of tuberculosis in free-ranging wildlife.
- Table 1.5** Free-ranging wildlife affected by *Mycobacterium bovis*.
- Table 2.1** Primers used for the amplification of elephant cDNA.
- Table 2.2** Results of the elephant cDNA amplification using a range of annealing temperatures and polymerase enzymes.
- Table 2.3** Results of the PCR products obtained after the amplification of rhinoceros cDNA using four different annealing temperatures and two different DNA polymerase enzymes.
- Table 3.1** Optimising the Imidazole concentration for protein purification on Ni<sup>2+</sup> matrix.
- Table 3.2** Optimising the volume of the Ni<sup>2+</sup> matrix using 0mM Imidazole.
- Table 3.3** Optimising the volume of Ni<sup>2+</sup> matrix using 20mM Imidazole concentration.
- Table 3.4** Protein concentration results.
- Table 4.1** Immunisation protocol for Balb/C mice.
- Table 4.2** Induction of cross-reacting antibodies.
- Table 4.3** Screening of the hybridoma clones.
- Table 4.4** Results of the sub-typing.

## LIST OF ABBREVIATIONS

<i>attB</i>	bacterial attachment site
<i>attL</i>	left attachment site
<i>attP</i>	phage attachment site
<i>attR</i>	right attachment site
BTB	bovine tuberculosis
Con A	concanavalin A
CSIRO	Commonwealth Scientific and Industrial Research Organisation
dNTPs	deoxynucleoside triphosphate
DTT	dithiothertol
ELISA	enzyme linked immuno-sorbent assay
FCS	fetal calf serum
GMCSF	granulocyte monocyte colony stimulating factor
GW	gateway
GDNA	genomic DNA
HUP	Hluhluwe-Umfolozi Park
IFN $\gamma$	interferon-gamma
Ig	immunoglobulin
IL	Interleukin
IHF	integration host factor
IMAC	immobilised metal affinity chromatography
ip	intra peritoneally
IPTG	isopropyl- $\beta$ -D-thiogalactopyranoside
KNP	Kruger National Park
LB	lauria broth
LTT	lymphocyte transformation test
MWCO	molecular weight cut off
MoAb's	monoclonal antibodies
NAAT	Nucleic acid amplification techniques
NDSB	non-detergent sulfobetaines
NVSL	National Veterinary Services Laboratory
PBMC	peripheral blood mononuclear cells
PBS	phosphate buffered saline
PCR	polymerase chain reaction
PEG	polyethylene glycol
PI	isoelectric point
PPD	purified protein derivative
REA	restriction endonuclease analysis
RFB1	refolding buffer one
RFB2	refolding buffer two
SDS-PAGE	sodium dodecyl sulphate –polyacrylamide gel electrophoresis
SIDT	single intradermal test
SICTT	single intradermal comparative tuberculin test
TB	tuberculosis
TNF $\alpha$	tumour necrosis factor alpha

## Chapter one

### Literature Review

#### 1.1 Introduction

Tuberculosis (TB) is a chronic, debilitating disease caused by either *Mycobacterium tuberculosis* or *Mycobacterium bovis* (Amadori et.al; 2002). These infectious agents belong to the *Mycobacterium tuberculosis* complex, which comprises of four species of tubercle bacilli, namely; *M.tuberculosis*, *M.bovis*, *M.africanum* *M.canettii* and *M.microti* (Montali et.al; 2001, Ashford et.al; 2001).

*Mycobacterium tuberculosis* is the main causative agent of human tuberculosis (Daborn; 1995). It remains one of lifes most threatening diseases and causes 2 million deaths per year (Anisa et.al; 2001). Since 1993 when the World Health Organisation (WHO) declared TB as a global health emergency there has been considerable research done on the biology of mycobacteria and their interactions with humans (Anisa et.al; 2001). This in turn, together with the current understanding of tuberculosis from a molecular point of view has brought many perspectives for tackling the disease. Although *M.tuberculosis* is responsible for infection in humans *M.bovis* is also responsible for an increasing proportion of human TB (Alexander et.al; 2002, Grange et.al; 1994).

Though uncommon, infection caused by *M.tuberculosis* has been described in domestic cattle and wildlife species living in close, prolonged contact with humans (Michalak et.al; 1998, Alexander et.al; 2002). *Mycobacterium bovis* on the other hand is commonly associated with tuberculosis in cattle and the disease is referred to as bovine tuberculosis (BTB) (Tanner et.al; 1999). Recently *M.bovis* has been found to have an exceptionally wide host range, which includes *M.bovis* infection in both captive and free-ranging wildlife (Morris et.al; 1994, Alexander et.al; 2002). Wildlife populations that are endemically infected include the European badger (*Meles meles*) in the United Kingdom (UK), the African buffalo (*Syncerus caffer*) in South Africa

and the Brushtail possum (*Trichosurus vulpecula*) in New Zealand (Buddle et.al; 2000, Alexander et.al; 2002).

The extensive documentation of tuberculosis in humans, domesticated cattle, captive and free-ranging wildlife populations like elephants, buffaloes, badgers and other mammals indicates that both *M.bovis* and *M.tuberculosis* are emerging as the most important agents of the disease in wildlife and humans, respectively.

## 1.2 Aetiology

Members of the *Mycobacterium tuberculosis* complex are slow growing, non-photochromogenic, acid-fast bacilli (Ashford et.al; 2001). In humans *M.bovis* primarily causes extra pulmonary TB. The disease may also occur in other places than the lungs, such as the lymph nodes, the pleura, the brain, the kidneys or the bones. In larger land mammals TB is usually caused in the majority of the cases by *M.bovis* (Montali et.al; 2001) and cattle and buffalo are the maintenance hosts.

## 1.3 Transmission

Spread of tuberculosis by *M.bovis* occurs primarily via the respiratory route, which holds true for humans as well (Ashford et.al; 2001, Morris et.al; 1994). Other routes of entry for *M.bovis* in human hosts are either via ingestion, direct contact with mucous membranes or broken skin. The principle vehicle for transmission to human hosts is contaminated milk. *Mycobacterium bovis* survives in soil and faeces for days to months depending on environmental conditions and thus providing ideal sources for bacterial transmission to animals (Ashford et.al; 2001). In cattle the disease is primarily spread by aerosol and in pigs via ingestion. However, not all infected animals spread the disease since asymptomatic or anergic carriers do occur (Ashford et.al; 2001).

A majority of wildlife do become infected by the airborne route and transmission occurs primarily when there are interactions between wildlife hosts and domestic animals (Morris et.al; 1994). Predators and scavengers seem to become infected by consuming infected prey (Morris et.al; 1994).

Zoonotic transmission of *M.bovis* has been reported from seals, rhinoceros and elk (Ashford et.al; 2001). The infection dose for humans is still not known. It has been estimated that 10's to 100's of organisms are infectious if the route of infection occurs via the respiratory route and millions are required if infections take place by the gastrointestinal route (Ashford et.al; 2001).

Studies on the infectious doses of *M.bovis* in animal models and the results of outbreak investigations indicated that the infectious dose is influenced by:

- Species of host: the dose is higher for humans than cattle.
- Host factors like immune status and the age of the animal: immune compromised individuals (e.g. FIV, HIV) and older hosts are more susceptible.
- Route of infection: a higher infection dose is needed when infection occurs via ingestion.

#### 1.4 Survival and Pathogenesis of *Mycobacterium bovis*

Mycobacteria are resistant to both chemical and physical agents, which assist them in surviving both in the body and in the external environment (Spitznagel; 1989). This obligate pathogen has the ability to survive for long periods in the environment under favourable conditions. Availability of nutrients, adequate levels of moisture, high pH and moderate temperatures assist in the survival of mycobacteria. *Mycobacterium bovis* and *M.tuberculosis* can survive up to 18-30 days when exposed to direct sunlight of temperatures between 24-34°C, and their survival increases to 150-332 days when shielded from direct sunlight (12-24°C) (Morris et.al, 1994). Since tubercle bacilli are highly resistant to drying they are capable of surviving for a long time in the air and dust (Spitznagel, 1989) thus allowing for the transmission of the disease to take place via the respiratory route (Spitznagel, 1989, Pollock et.al; 2002).

Inhalation of *M.bovis* by cattle is by far the most important route of bovine infection (Pollock et.al; 2002). An alternate route of transmission is the direct ingestion of *M.bovis* from infected animals or from contaminated pastures or water.

The process of disease starts once infection is established and this occurs when the animal inhales tubercle bacilli or a single bacillus in an aerosol droplet (Spitznagel, 1989, Neill et.al; 1991, Pollock et.al; 2002). The droplet nucleus enters the respiratory tract until it gains access to the alveoli where it multiplies (Spitznagel, 1989). Resident macrophages of the alveoli begin ingesting the bacilli. These organisms multiply within these and other non-resident macrophages, which collect in the area of infection. Macrophages loaded with mycobacteria migrate to the lymph nodes, where an immune response develops which is dominated by T-helper cells (Spitznagel, 1989, Pollock et.al; 2002). Activated macrophages cannot always destroy the tubercle bacilli, some bacilli kill the macrophages, and other macrophages are themselves killed, so releasing the bacterial content. This involvement of macrophages results in the production Interleukin-1 (IL1) and tumour necrosis factor (TNF), which contributes to the symptoms of the disease. Interleukin-1 acts as the mediator of the fever experienced by the animals. Tumor necrosis factor interferes with lipid metabolism and leads to severe weight loss. At this stage inflammation presents itself at the original site of infection and the regional lymph nodes. The above-mentioned sequence of events usually occurs within 30 days. Mycobacteria are slow growers but during this time multiply considerably and are thus found in large numbers. The disease then reaches a stage of infection where the immune system has managed to curb the proliferation of bacilli and retard local spread (Spitznagel, 1989). A small number of bacilli may enter the blood stream and be disseminated throughout the body (Ashford et.al; 2001, Spitznagel, 1989). *Mycobacterium bovis* bacilli adapt themselves within the macrophages and inadvertently become naturally resistant to oxidative burst. This property gives them the ability to multiply and destroy phagocytes and escape into intracellular spaces. This results in the accumulation of other phagocytes, creating the typical histopathological lesions of TB called granulomas. Granulomas continue to expand with new phagocytic cell infiltration, giant cell formation and fibrosis (Ashford et.al; 2001). With time tubercles are formed and the centres of these macroscopic lesions become necrotic and advance to acellular masses of debris and the resulting disease is known as TB (Spitznagel, 1989, Ashford et.al; 2001). The period of incubation can last from weeks to decades (Ashford et.al; 2001).



## 1.5 Epidemiology

Bovine tuberculosis is a worldwide disease and diverse populations of wildlife are susceptible to infection by *M.bovis* and *M.tuberculosis* (Rodwell et.al; 2001). Countries affected by this disease include the United Kingdom (UK), United States of America (USA), Canada, New Zealand, Australia, Denmark, Sweden, Norway and Southern Africa (Ashford et.al; 2001). Table 1.1 shows the reservoirs of BTB throughout the world (Ashford et.al; 2001).

**Table 1.1** Reservoir hosts of BTB throughout the world

<b>Known reservoir hosts</b>	<b>Country</b>
Brush tail opossums	New Zealand
Badgers	UK and Ireland
Deer	USA
Bison	Canada
Kudu African Buffalo	Southern Africa

(Adapted from Ashford et.al; 2001)

The largest wildlife refuge in South Africa is the Kruger National Park (KNP). It has an area of 20 000 km<sup>2</sup> and stretches from the Crocodile River in the south up to the Limpopo River, which is the international border in the north (Rodwell et.al; 2001). In July 1990 BTB was diagnosed in a 2-year-old emaciated African buffalo bull (*Syncerus caffer*) in the southwestern boundary of the KNP (Bengis et.al; 1996). The disease in the buffalo in the KNP showed a chronic predominantly subclinical disease. The results of the necropsy indicated that the lungs and the upper respiratory tract were exclusively involved. Further evidence from histopathological findings suggested that buffalo are extremely susceptible and that this disease is progressive within the herd context (De Vos et.al; 2001).

Rodwell and co-workers (2001) carried out a survey to determine the prevalence of BTB in African buffalo in the Park. This and other surveys, which were conducted between 1990 and 1996, revealed that BTB probably entered the KNP ecosystem

from across a river on the southern boundary, an area that was once inhabited by infected domestic cattle herds (Rodwell et.al; 2001, De Vos et.al; 2001). Table 1.2 indicates the estimation of the prevalence of BTB in the KNP from 1991-1998.

**Table 1.2** Prevalence of BTB in the Kruger National Park from 1991-1998

Prevalence of BTB	Zones in KNP	Estimation
1991/1992	North	0%
	Central	4.4%
	South	2.0%
*1998	North	1.5%
	South	1.6%
	Central	38.2%

\*Stratified, two-stage cluster sampling method used for estimating disease prevalence. (Rodwell et.al; 2001).

In order to further understand disease transmission risks, potential population effects and efficacy of disease management strategies, monitoring of BTB has to continue in the Park (Rodwell et.al; 2001).

Since the first diagnosis of BTB in an African buffalo in 1990 in the KNP the disease has reached epidemic proportions (Keet et.al; 1996). The disease has already “spilled over” into chacma baboon (*Papio ursinus*), lion (*Panthera leo*), cheetah (*Acinanyx jubatus*), kudu (*Tragelaphus stesiceros*), honey badger (*Mellivora capensis*), hyena (*Crocuta crocuta*), warthog (*Phacochoerus aethiopicus*) and leopard (*Panthera pardus*) (Keet et.al; 1996, Tanner et.al; 1999, De Vos et.al; 2001). Outside the KNP, bovine tuberculosis has been reported in the Hluhluwe-Umfolozi Park (HUP) in KwaZulu Natal as well as in Uganda, Kenya and Zambia (see Table 1.3) (Wildlife tuberculosis Study Group; 2001).

In 1970, the first case of a mycobacteriosis, which histologically resembled BTB, was diagnosed in a black rhinoceros in the HUP area. In 1996 another suspect case was

found in a rhinoceros but remained unconfirmed (Wildlife Tuberculosis Study Group; 2001).

In 1986 BTB was diagnosed in buffalo and in 1992 in lion at the HUP. The suspected agent in these cases was *M.bovis*. Surveys performed in 1992 indicate that BTB was probably introduced in the extreme west and the southern part of the Park, current surveys confirm this indicating a high prevalence of BTB in the south and west with decreasing prevalence towards the north of HUP. Table 1.3 summarizes the occurrences of BTB in Africa in free ranging wildlife.

Tuberculosis was first described in both Asian and African elephants over 2000 years ago (Mikota et.al; 2000, Mikota et.al; 2001, Montali et.al; 2001). However, within the past seven years, tuberculosis (TB) has emerged as a disease of concern in elephants, mainly in North America (Mikota et.al; 2000) and most frequently reported in Asian elephants (*Elephas maximus*). The causative agent in all cases of TB in elephants in which bacteria have been isolated is *Mycobacterium tuberculosis* (Mikota et. al; 2000). *Mycobacterium tuberculosis* is primarily a human pathogen; infections in animals have been called inverse zoonosis (Ryan, 1997). To date two suspected cases in African elephants (*Loxodonta africana*) in Uganda and Israel were reported but not confirmed by culture. However, *M.tuberculosis* was isolated from an African elephant in France (Mikota et.al; 2000).

A retrospective medical study of 379 elephants that was performed in North American zoos noted the deaths of 8 Asian elephants from TB between 1908 and 1994 (Mikota et.al; 2000, Mikota et.al; 2001). The figure would probably have been higher if privately owned elephants were also included in the survey.

Recently (between August 1996 and June 2000) 17 cases of TB was confirmed to be caused by *M.tuberculosis* in Asian elephants, only in North America (Mikota et al; 2001, Montali et.al; 2001). The frequency of TB infection in elephants in North America is estimated to be 3.3% and this figure is based on studies that were performed on the 539 elephants samples in the database of the National Veterinary Services Laboratory (NVSL, Ames, IA), USA, and 532 of these elephants were identified by the North American Regional Studbook Keepers (Mikota et.al; 2000).

The low incidence of TB in African elephants and or the absence of reports of TB in free-ranging elephants suggest that this is primarily a disease caused due to contact with humans and the elephants are accidental hosts (Mikota et.al; 2001).

A case of BTB in a 24-year-old female rhinoceros was reported in a zoo in Los Angeles (Song, 2001). Another reported case of TB in a rhinoceros was by Mann and co-workers in 1981. They reported that a black rhinoceros died at the National Zoological Park, USA, from generalized TB that was caused by *M.bovis*. Nine months later another black rhinoceros was euthanized after *M.bovis* was cultured from its lungs (Mann et.al; 1981). There has been no documented case of BTB in rhinoceros in Africa.

**Table 1.3** Known occurrences of BTB in Africa in free-ranging wildlife

Country	Area/Region	Species	First identified
Uganda	Kidepo Valley NP	African Buffalo	1999
	Queen Elizabeth NP	African Buffalo	1963
		Warthog	1982
Kenya	Masai Mara Region	Olive baboon	1985
Zambia	Kafue NP	Kafue lechwe	1972
South Africa	Kruger NP (including surrounding)	African Buffalo	1990
		Lion	1995
		Greater Kudu	1996
		Chacma baboon	1995
		Cheetah	1995
		Leopard	1998
		Rusty spotted genet	1999
		Spotted hyenas	2000
		Warthog	2000
	Hluhluwe-Umfolozi Park	African Buffalo	1986
		Lion	1992
		Chacma baboon	2000
		Bushpig	2000
		Rhinoceros	1970,1996
	KwaZulu-Natal (Spioenkop Nature Reserve)	Greater kudu	2001
	Eastern Cape Region	Greater kudu	1928

(Source: Wildlife Tuberculosis Study Group: <http://wildlifetb.greensponsors.com/map.htm>)

## 1.6 Clinical Signs, Symptoms and Pathological Aspects

Tuberculosis caused by *M.bovis* is a chronic progressive disease and since the signs usually do not show for the majority of the course of infection, animals that are infected will appear clinically normal (De Lisle et.al; 2002).

Common clinical signs are weight loss, swollen lymph nodes, abscesses and signs associated with tuberculous pneumonia, such as coughing. Weight loss is a symptom that usually occurs during the advanced stages of the disease. Table 1.4 summarizes the clinical signs of tuberculosis observed in a selection of different wildlife species (De Lisle et.al; 2002).

Environmental factors such as the lack of grazing during droughts can exacerbate the severity of the clinical signs. It has been observed that behavioural changes may occur in some species during the advanced stages of TB. Examples include Brushtail possums and baboons; Brushtail possums are nocturnal creatures but are found moving about during daylight. Baboons that are normally social become depressed and solitary. Behavioural changes therefore seem to play an importance in the spread of infection to other animals.

**Table 1.4** Clinical signs of tuberculosis in free-ranging wildlife

<b>Species</b>	<b>Clinical signs</b>
Badger ( <i>Meles meles</i> )	Weight loss, open lesions, behavioural changes.
Wood bison ( <i>Bison bison</i> )	Weight loss, dull coat and dry coughing in advanced cases.
Possum ( <i>Trichosurus vulpecula</i> )	Weight loss, discharging abscesses, behavioural changes.
Asian elephants ( <i>Elephas maximus</i> ) African elephants ( <i>Loxodonta africanum</i> )	Weight loss, anorexia, weakness, dyspnoea and coughing.
African buffalo ( <i>Syncerus caffer</i> )	Weight loss, hoarse, dry coughing, dyspnoea, dull coat, arched back, and depression.
Greater kudu ( <i>Tragelaphus strepsiceros</i> )	Swollen parotid, retropharyngeal and cervical lymph nodes discharging fistulae, terminal weight loss, coughing and depression.
Lion ( <i>Panthera leo</i> )	Weight loss, swollen joints, elbow hygromas, lameness, corneal opacities, dull coat, poorly healing skin wounds and depression.
Baboon, chacma ( <i>Papio ursinus</i> )	Weight loss, coughing, dyspnoea, dull moth-eaten coat, behavioural changes, swollen peripheral lymph nodes
Leopard ( <i>Panthera pardus</i> )	Weight loss, dull coat, and poorly healing wounds.
Cheetah ( <i>Acinonyx jubatus</i> )	Weight loss, dull coat, alopecia and poorly healing wounds.
Hyena ( <i>Crocuta crocuta</i> )	Slight weight loss.
Warthog ( <i>Phacochoerus aethiopicus</i> )	Weight loss, dyspnoea.

(De Lisle et.al; 2002, Keet et.al; 1996, Mikota et.al; 2001)

1.6.1 Clinical symptoms and pathological findings in elephants infected with *Mycobacterium tuberculosis*

Symptoms in elephants affected by tuberculosis caused by *M.tuberculosis* include loss of appetite, weight loss, reluctance to do strenuous work and occasionally subcutaneous ventral oedema (De Lisle et.al; 2002, Mikota et.al; 2000).

Pathological findings indicate that the lungs and thoracic lymph nodes are primarily involved when infection occurs with *M.tuberculosis* (Mikota et.al; 2000, Montali et.al; 2001). Tubercular lesions also occur and vary with the staging of the disease (Mikota et.al; 2000). Elephants with extensive involvement of both lungs usually die with severe caseo-calcareous and cavitating lesions, often resulting in large pulmonary abscesses. In the less extensive cases, firm granulomatous nodules occur in the bronchial lymph nodes and pulmonary tissue. Bronchial and other thoracic lymph nodes are extensively enlarged and usually show a proliferative response with less caseation than the pulmonary lesions (Mikota et.al; 2000).

Characteristic histological findings include epithelioid granulomas with significant giant cell formation in the earlier lymph nodes and pulmonary lesions and extensive caseous and pyogranulomatous pneumonia in the advanced forms. The presence of acid-fast bacilli in the areas of caseation in the lungs is common but typically rare in the lymph nodes (Mikota et.al; 2000, Montali et.al; 2001).

1.6.2 Clinical symptoms and pathological findings in rhinoceros

The prevalence and clinical symptoms of TB in rhinoceros has not been well studied and cases that have been described in literature (Mann et.al; 1989, Song, 2001) include general TB symptoms found in animals and the information regarding pathologic studies are few and not well documented.

1.6.3 Pathology in other animals affected by tuberculosis

***African Buffalo (Syncerus caffer)***

The presence of caseo-granulomas in lymph nodes and lesions in the lungs varies from tuberculous pneumonia with areas of caseation to solid confluent caseous-granulomas. These lung lesions, whether focal or disseminated, may progress to



cavitation with liquefaction. These cases are extremely infectious (De Lisle et.al; 2002, Grobler et.al; 2002).

***Other wildlife***

The most common site of *M.bovis* infection in maintenance hosts, e.g. African buffaloes and Brushtail possums, including Kafue lechwe (*Kobus lechekafuensis*) is the thoracic cavity (De Lisle et.al; 2002). In the KNP infected baboons that were examined had generalized lesions with macroscopic granulomas in the spleen, lungs and mesenteric lymph nodes.

Generalized lesions observed in tuberculous lions and leopards do not resemble these found in herbivores and omnivores. Abscessation, caseation and calcification are absent and lesions appear proliferative with scanty mucoid exudates. Macroscopic lesions were found in the lungs of two cheetahs with confirmed bovine tuberculosis. Lesions consisted of numerous scattered granulomas; many containing liquefied caseous necrotic exudates (Neill et.al; 1994, Keet et al; 1996, De Lisle et.al; 2002).

Table 1.5 illustrates examples of the most common sites for gross tuberculous lesions in free-ranging wildlife (De Lisle et.al; 2002).

**Table 1.5** Free-ranging wildlife affected by *Mycobacterium bovis*

Host species	Most common site of gross lesion	Route of transmission	Epidemiological status
Possum	Lungs, superficial lymph nodes	Respiratory	Maintenance host
Badger	Lungs	Respiratory	Maintenance host
Bison	Head, thoracic lymph nodes and lungs.	Respiratory	Maintenance host
African buffalo	Lungs, thoracic and head lymph nodes.	Respiratory	Maintenance host
Lechwe antelope	Thoracic lymph nodes and lungs	Respiratory	Maintenance host
Deer, red	Head lymph nodes costal/pleural	Respiratory/oral	Spillover host <sup>a</sup>
Greater kudu	Head lymph nodes and lungs	Scarification/oral	Spillover host <sup>a</sup>
Warthog	Head lymph nodes and lungs	Oral/respiratory	Spillover host <sup>a</sup>
Ferret	Mesenteric lymph nodes	Oral	Spillover host <sup>a</sup>
Baboon	Mesenteric lymph nodes, spleen and lungs	Oral/respiratory	Spillover host
Feral pig	Head lymph nodes	Oral	Spillover host
Bobcat	Mesenteric lymph nodes	Oral	Spillover host
Coyote	Mesenteric lymph nodes	Oral	Spillover host
Raccoon	No gross lesions	Oral	Spillover host
Red fox	No gross lesions	Oral	Spillover host
Lion	Mesentric and peripheral nodes, skin, lungs, bones and joints	Oral/respiratory <sup>b</sup>	Spillover host
Leopard	Mesenteric and peripheral nodes, skin and lungs.	Oral/respiratory	Spillover host
Cheetah	Lungs and skin	Oral/respiratory <sup>b</sup>	Spillover host
Hyena	No gross lesions	Oral	Spillover host
Common genet	Thoracic lymph nodes	Oral	Spillover host

<sup>a)</sup> in high densities, ferrets, greater kudu, warthogs and wild red deer may be maintenance hosts of *M.bovis*.

<sup>b)</sup> possible alternative route of transmission (De Lisle et.al; 2002)

## 1.7 Diagnostic approaches

As mentioned previously the majority of the animals infected with TB do not show any clinical signs of the disease until it has reached advanced stages. There are a variety of diagnostic tests available for tuberculosis but these tests are limited to certain species only. Means of detection and diagnosis of TB in animals range from immunologically based diagnostic tests, like *in vivo* cell-mediated immune-based tests and serological tests, to post mortem diagnosis, microbiological approaches, rapid DNA amplification procedures and DNA fingerprinting. Standard diagnostics in human tuberculosis include skin testing and radiographic testing of the lungs. In domesticated animals infection is usually diagnosed by the intradermal tuberculin skin tests or using BOVIGAM™ as described in 1.7.5.3. BOVIGAM™ can only be used in cattle and certain other bovine species.

Our concern lies in diagnosing TB in pachyderms and other wildlife, which may serve as a reservoir of infection. A number of challenges arise in detecting tuberculosis in free-ranging wildlife. Currently techniques used for diagnosis are of relevance where wildlife species are an indigenous protected species and post mortem samples are not often available (De Lisle et.al; 2002). These techniques have limitations but also have the potential for determining both the existence of TB within a population and also the prevalence of the infection in that population (De Lisle et. al; 2002).

A few of the diagnostic approaches will be discussed.

### 1.7.1 Microbiology

Detection of acid-fast bacilli after Ziehl-Neelsen staining in a smear of suspect tuberculous lesions can be performed as a presumptive diagnosis. Results, however, should be interpreted with caution because failure to see acid-fast organisms in a smear does not rule out the presence of *M.bovis*. This also is an insensitive procedure.

Lesions containing acid-fast bacteria may also be caused by species of mycobacteria other than *M.bovis*. Bacterial culture is the gold standard for establishing a diagnosis of TB. It is a sensitive and specific technique but has the disadvantage of requiring several weeks to months to isolate and then to identify the mycobacterium (De Lisle et.al; 2002).

### 1.7.2 Rapid DNA amplification procedures

Polymerase chain reaction (PCR) is a DNA amplification procedure that has the potential of being specific, sensitive and rapid. Insertion sequences IS6110 and IS1081 are specific to the mycobacteria belonging to the mycobacterium tuberculosis complex and the sequences of these insertions were used in PCR techniques to determine the presence of *M.tuberculosis* and *M.bovis* in cattle with suspect tuberculosis (Skuce et.al; 1994). In order to detect *M.bovis* from tissue samples many investigators have employed the technique of DNA amplification but none of the procedures have achieved the sensitivity, specificity and reliability of bacterial cultures (Cavirani et.al; 1999, De Lisle et.al; 2002).

### 1.7.3 DNA finger printing

DNA typing is widely used for epidemiological studies of bacterial infections, although none of the systems that have been used for examining strains of *M.bovis* are ideal. Restriction endonuclease analysis (REA) was the first useful typing system for *M.bovis* and has been used extensively in New Zealand to study the epidemiology of BTB especially the complex cycle of infection involving wildlife and domestic animals (Buddle et.al; 2000, De Lisle et.al; 2002). Although REA has the sensitivity to yield valuable epidemiological information, the method has the drawback of being technically difficult to perform and requires 8 weeks to obtain a final result.

Spoligotyping and restriction fragment length polymorphisms (RFLP) are other methods of DNA typing used to examine strains of *M.bovis* (Skuce et.al; 1994, Collins et.al; 1994). In order to type the isolates from the various maintenance and spillover hosts in the KNP an RFLP technique using IS6110 (Refer to 1.7.2) was used and a single dominant genotype was identified as ZA-01. This genotype was found to be the cause of infection in most buffalo and spillover hosts. This genotype was also isolated from cattle south of the KNP, from where the initial source of infection of buffalo was suspected to have originated (De Lisle et.al; 2002).

### 1.7.4 Immunologically based diagnostic tests

The principle of immune based tests for the detection of tuberculosis in wildlife is based on the presence of an intracellular bacterium that does not produce toxins.

During the early pre-clinical stages of TB, cell-mediated immune responses predominate and enhance the ability of macrophages to restrict the multiplication of this intra-cellular parasite. A large number of organisms are present in the advanced stages of the disease and it is usually during this stage that high levels of antibody to mycobacteria occur. Specificity of these tests depends on the type of on antigens used for the diagnosis of TB. Until recently crude preparations of purified protein derivatives (PPD) that are used for skin testing was used. Due to the exposure of other bacterial species having identical antigens to those found in *M.bovis* false positive results occur. In most cases, however, causes of false positive responses are not determined.

#### 1.7.4.1 Serological tests

Serology involves the use of antigen: antibody reactions for the diagnosis of disease. Serologic tests rely on the detection of antigen (Ag) binding to antibodies (Ab) and a serological test may detect either

- The presence of an Ag in the sample
- The presence of an Ab in the sample

Interpretation of these tests results is highly dependent on whether Ag/Ab is detected by the test (Levy et.al; 1994).

Serology has been used to detect TB in a range of different host species including wildlife. Serological tests performed in the 1960s and 1970s for the detection of bovine TB included the bentonite flocculation test (Wallace et.al; 1968, Lepper et.al; 1973), the kaolin agglutination tests (Yugi & Nozaki; 1972), the indirect-fluorescent antibody test (Lepper & Pearson; 1975) and the complement fixation test (Vardaman & Larson; 1964). These systems made use of crude antigen preparations. They showed cross-reactivity with sera from uninfected cattle and cattle with other mycobacterial infections. In addition it relayed poor specificity and low sensitivity and a number of tuberculous cattle gave negative reactions (Wood et.al; 1994).

A combination of a lymphocyte transformation test and a direct ELISA used by Griffin and co-workers (1994) yielded high levels of sensitivity and specificity when BTB was detected in farmed deer. The drawback was that acceptable levels of

sensitivity in the ELISA was only achieved if testing was done ten days after an IDT that significantly boosted the levels of specific antibody (a so called anamnestic ELISA).

In England, Stuart (1989), developed a competitive ELISA for the diagnosis of TB in deer. This ELISA involved the competition between *M.bovis* specific antibodies in infected deer sera and *M.bovis* specific mouse monoclonal antibodies conjugated with enzymes. Tests showed a high specificity (100%) but the sensitivity was less than 50% making the test unreliable for TB diagnosis in deer (Griffin et.al; 1994).

An extensive research programme was performed in the United Kingdom to develop a serological test for identifying bovine tuberculosis in badgers. This test (Brock Test), a blocking ELISA, used a monoclonal antibody against a 25kDa antigen of *M.bovis* that was found to be immuno-dominant in badgers. The sensitivity and specificity was 37% and 98% respectively. The sensitivity was regarded as too low to form the basis of a sustainable test for a control programme based on a test and cull strategy (Nolan et.al; 1994, Amadori, et.al; 2002, De Lisle et.al; 2002).

Low levels of sensitivity had also been observed in serological tests developed for detecting TB in Brushtail possums. Positive responses were most commonly found in possums in the terminal stages of the disease than in the subclinical stages of *M.bovis* infection (Buddle et.al; 1995).

#### 1.7.4.2 Cell mediated immune responses to TB

Immune responses to mycobacterial infections are predominantly cellular in nature and immune responses to *M.tuberculosis* and *M.bovis* in animals are highly dependent on IFN $\gamma$  production by macrophages and antigen-specific T-cells (Katial et.al; 2001, Wood et.al; 1991, 1992, 1994, Billman-Jacobe et.al; 1992, Pearl et.al; 2001). Therefore current diagnostic tests for mycobacterial diseases are based on the measurement of cellular responses (Wood et.al; 1994, 1991).

In cattle the principal tool used for identifying infected cattle herds is the intradermal tuberculin test.

### ***The Tuberculin Reaction***

The tuberculin reaction, first described in 1891 by Robert Koch, has been used for the diagnosis of tuberculosis in cattle for more than 100 years (Monaghan et.al; 1994, Wood et.al; 1994, Wood et.al; 1991).

Tuberculin is the extract of *M.tuberculosis*, *M.bovis*, or *M.avium*. Several types of tuberculin available, purified protein derivatives (PPD) are prepared by growing organisms in synthetic medium and then killing them in steam and filtering. The PPD tuberculin is precipitated from this filtrate and resuspended in buffer ready for use (Tizard; 1992). Two types of tuberculin tests are currently in use. One is the single intradermal test (SIDT), which uses bovine tuberculin, and the second type is the single intradermal comparative tuberculin test (SICTT), which uses avian and bovine tuberculins (Monaghan et.al; 1994).

The tuberculin reaction is an immunologically specific inflammatory reaction mediated by T-cells induced by injection of PPD into the skin. In a normal animal there is no response. In an animal sensitized by infection (or experimental immunization) with mycobacteria, a delayed hypersensitivity response will occur. Following the intradermal injection of tuberculin into a sensitized animal, a red, indurated (hard) swelling slowly develops at the injection site. Inflammation begins between 12 and 24 hours, reaches its greatest intensity by 24 to 72 hours and may persist for several weeks before gradually fading (Tizard; 1992, Monaghan et.al; 1994).

The ability of different species to mount a classic tuberculin reaction varies greatly. In pig and cat the tuberculin test is unreliable. In sheep and goats the antigen is usually given in the anal fold but results have shown to be unreliable. Brushtail possums and badgers produce only weak responses with the IDT. Results obtained do not always correlate well with the disease status of the animal (Tizard; 1992).

Dr. Dewald Keet, a veterinarian in the KNP, has implemented an adaptation of the tuberculin skin test used in cattle in diagnosing lions for tuberculosis. This test has proved to be both reliable and accurate but the disadvantage is that the lion has to be captured by darting using chemical immobilizers so that the test can be performed and

then the animal is released. The animals have to be recaptured three days later in order to take the reading.

Intradermal tests are associated with high costs and high levels of handling stress to animals due to the double immobilization (Grobler et.al; 2002). Tuberculin testing decreased the response to subsequent testing for a period of 60 days and therefore cattle cannot be reliably retested during this time (Wood et.al; 1994). Wood and co-workers (1994) also found that tuberculin testing of *M.bovis* infected cattle also affects the animals' IFN $\gamma$  response. Intradermal testing has to be standardized for each species (Tizard; 1992). Research on the development and evaluation of antigens to *M.bovis* and *M.tuberculosis* is necessary to improve the sensitivity and specificity of the tuberculin test (Monaghan et.al; 1994). Despite its disadvantages the tuberculin reaction has proven to be a convenient, cost-effective method for assessing cell-mediated immune responses to a variety of antigens (De Lisle et.al; 2002, Katial et.al; 2001).

### ***Lymphocyte Transformation Tests***

*In vitro* methods to measure T-cell reactivity of cells from *M.bovis* infected cattle include the lymphocyte transformation test (LTT) (Wood et.al; 1994). Lymphocyte transformation tests involve the co-culture of separated mononuclear leucocytes with PPD-B (bovine) and PPD-A (avian) and selected mycobacterial peptides. Lymphocyte transformation tests were also used to detect TB in deer herds (Griffin et.al; 1994). Results of the initial pilot studies have shown that LT has a sensitivity of 95% and a specificity of 92% for TB diagnosis in infected herds.

This system has several disadvantages:

- The technique of isolating lymphocytes from blood is time consuming and restricts the number of animals that can be tested.
- The cells have to be incubated in complex tissue culture media for 3-5 days.
- Detection of the level of cell proliferation requires the use of radioactive nucleosides.

Lymphocyte proliferation assays are therefore far too complex, costly and slow for use as a practical means of diagnosing TB in animals (Wood et.al; 1994, Griffin et.al;



1994). As an alternative to the LTT, Wood and co-workers (1994) have developed a whole blood incubation system (See 1.7.5.3), which examines the release of cytokine IFN $\gamma$  as a positive response to *M.bovis* antigen (bovine PPD).

### 1.7.5 Cytokine assays

#### 1.7.5.1 Cytokines in general

Cytokines are low molecular weight glycoproteins secreted by the cells of the immune system (Tizard; 1992, Male; 1991, Whiteside; 2002). The functions of cytokines include the regulation of immunologic responses (Whiteside; 2002), differentiation and division of haemopoietic stem cells (Male; 1991), and cell-to-cell communication (Whiteside; 2002). The production of cytokines is stimulated by a variety of signals including infectious agents and other inflammatory stimuli. They also act on many different cellular targets (Tizard; 1992). Cytokines may both act on cells other than those that produce them (paracrine effect) or on those cells that produced them (autocrine effect) (Male, 1991). They may spread throughout the body and affect cells in distant locations and thus have a systemic effect (Tizard; 1992).

Cytokines are both pleiotropic as well as redundant (Whiteside, 2002). The pleiotropic effects occur when a cytokine acts on a large number of different target cells inducing different responses in each one. Redundancy is depicted when many different cytokines may act on a single cellular target (Tizard, 1992).

Since cytokines mediate interaction between various cells their deregulated production might contribute to disease pathogenesis. At low levels cytokines are not detectable in body fluids and tissues. Their presence, therefore at elevated levels of expression indicates activation of cytokine pathways associated with inflammation or disease progression (Whiteside, 2002). Therefore it is and can be important to make an assessment of cytokines in body fluids, tissues or cells of patients with various diseases.

#### 1.7.5.2 Interferon gamma (IFN $\gamma$ )

Amongst cytokines the Th1-type cytokines (e.g. IL2, IFN $\gamma$ , TNF $\alpha$ ) are of relevance in induction of cellular immune responses towards intracellular pathogens like mycobacteria. In contrast Th2-type cytokines (e.g. IL3, IL4, IL5, IL13) are involved in promoting antibody-mediated responses (Whiteside; 2002).

The cytokine of interest and significant to this study is interferon-gamma (IFN $\gamma$ ). Interferon-gamma is not related to the other interferons. It is so named because of its antiviral activity. IFN $\gamma$  is produced by CD4<sup>+</sup> T-cells as well as some CD8<sup>+</sup> T-cells and by natural killer (NK) cells. It acts on B cells, T cells, NK cells and macrophages.

Functions of interferon-gamma (IFN $\gamma$ ) are:

- Enhances production of MHC class I molecules by T-cells.
- Induces Th1 cells to produce both IL2 and IL2R.
- Acts on Th2 cells to inhibit the production of IL4.
- Enhances the activities of NK cells.
- Activates macrophages and increases their ability to destroy ingested microorganisms, thus it plays a major role in IDT as *in vivo* cellular assay.
- Promotes antibody-mediated phagocytosis.
- Up-regulates the expression of MHC class 1 and 2 molecules on virus-infected cells (Tizard; 1992, Male; 1991).
- Stimulates B-cells to production of IgG2a in mice.
- May reduce production of IgG3, IgG1, IgG2b and IgE in mice

#### 1.7.5.3 BOVIGAM<sup>TM</sup>

An assay has been developed based on the induction of IFN $\gamma$  in antigen-stimulated blood cultures for detection of cattle with *M.bovis*. This assay is called BOVIGAM-Bovine Gamma Interferon Test (Trademark of CSL, Australia). Unlike the skin test, BOVIGAM<sup>TM</sup> is a relatively non-invasive, *in vitro* test that is performed in two stages.

*Stage one:*

Whole blood culture – Blood samples are incubated with tuberculin purified protein derivatives (PPD's), as used in IDT, to stimulate lymphocytes to produce IFN $\gamma$ . Blood collected in heparin is dispensed into 24-well culture tray wells and mixed with specific antigens. The plasma supernatant from each blood aliquot is harvested for IFN $\gamma$  estimation after incubation (Rothel et.al; 1990, Wood et.al; 1990, Rothel et.al; 1992 Wood et.al; 1994).

*Stage two:*

Bovine IFN $\gamma$  ELISA - IFN $\gamma$  in the plasma supernatants of each blood aliquot is estimated using a sandwich ELISA. Relative levels of IFN $\gamma$  detected in the samples indicate whether an animal is infected with *M.bovis* (Rothel et.al; 1990, Wood et.al; 1990). In addition the problem of false positive reactions, due to environmental mycobacteria can be overcome by using a comparative assay in animals' IFN $\gamma$  response to both bovine and avian PPD is compared.

In South Africa BOVIGAM™ has shown promise in diagnosing *M.bovis* infection of African buffalo (*Syncerus caffer*) (Grobler et.al; 2002). The limitation of this assay is that monoclonal antibodies used in the ELISA will only recognize the interferon-gamma of a limited number of ruminant species including cattle, sheep and goats.

The success of this test and similar ones e.g. PRIMAGAM and CERVIGAM in detecting mycobacterial infections in a number of species has stimulated us to develop a similar test for pachyderms.

#### 1.7.6 Pachyderms and tuberculosis

##### 1.7.6.1 Diagnosis of *M.tuberculosis* in elephants

Definitive ante-mortem diagnostic techniques for TB in elephants have limitations and intradermal skin testing has only been validated in domestic cattle, bison and cervidae (Mikota et.al; 2001). Diagnosis of *M.tuberculosis* in infected elephants is done by culturing. Respiratory secretions are obtained by “trunk wash”. The trunk wash procedure involves the instillation of 60ml of sterile saline into one or both the nostrils. Thereafter a 1-gal plastic bag is placed over the end of the trunk. The trunk is

elevated to distribute the saline. The forcibly exhaled sample is collected into the bag. This bacterium is known to be shed intermittently therefore 3 samples are collected on separate days (Mikota et.al; 2000). Mycobacterial culture results in elephants when compared with intradermal and serologic tests to date show poor correlation. Since 1996, 445 *M.tuberculosis* cases in elephants were positively diagnosed by culture but negative responses were obtained with the IDT (Mikota et.al; 2000). Nucleic acid amplification techniques (NAAT) are rapid and are capable of detecting low numbers of organisms and this technique has reported to have high specificity for *M.tuberculosis* complex organisms. Nucleic acid amplification techniques (NAAT) are of limited value in monitoring response to therapy because both live and dead organisms are detected (Mikota et.al; 2000).

Mikota and co-workers also performed a blood TB test in 2001 on elephants as a composite test consisting of ELISA reactivity against mycobacterial antigens and lymphocyte stimulation. The blood TB test showed a sensitivity of 83.3% and a specificity of 51.6%. The result, however, showed poor consistency when tests were repeated. ELISA results did not correlate with trunk cultures. A number of elephants that were trunk culture negative had positive ELISA results. They therefore concluded that the practical application of the ELISA in the diagnosis of TB in elephants has yet to be determined (Mikota et.al; 2001).

In response to TB in elephants a set of guidelines for the testing, treatment and surveillance of *M.tuberculosis* complex in elephants was created and compiled by the National Tuberculosis Working Group for Zoo and Wildlife Species in the USA (Mikota et.al; 2001).

Treatment of TB in elephants is preferred rather than test and slaughter practices that are practiced in domestic animals like cattle. The treatment of elephants was once reported in an Asian elephant. The elephant was treated with streptomycin, which was administered intramuscularly on alternate days for 4 weeks. Current treatment strategies are still ongoing and under investigation for efficacy in elephants (Mikota et.al; 2000). Since blood level responses are variable, the dry doses of anti-TB drugs have to be determined for each elephant before administration to the elephants. In

addition the elephants have to be weighed before and throughout the treatment (Mikota et.al; 2000).

#### 1.7.6.2 Diagnosis of *M.bovis* infection in elephants

*Mycobacterium tuberculosis* is responsible for most of the TB cases in elephants reported in literature. The IDT tests that were performed in elephants (Mikota et.al; 2001) were performed with PPD prepared from *M.bovis*. The results of the IDT showed no correlation with culture results and of the six elephants that were positive for *M.tuberculosis* only one had a suspect tuberculin reaction. From the 31 *M.tuberculosis* culture negative elephants tested eight showed suspect reactions and 23 did not respond to the reaction (Mikota et.al; 2001).

#### 1.7.6.3 Diagnosis of *M.tuberculosis* and *M.bovis* in rhinoceros

From the methods applied to diagnose tuberculosis in domestic animals, culturing has been the only means used to diagnosing TB in rhinoceros. From the literature only three cases of BTB were reported in rhinoceros and all three cases were reported to have been caused by *Mycobacterium bovis*. The IDT is currently being investigated and been validated as a means of detecting TB in rhinoceros. There are currently no other techniques available for diagnosing these animals for TB and indirect methodologies such as serologic assay and cellular responsiveness to mycobacterial antigens lack validation in non-domesticated animals.

With elephants and endangered animals like rhinoceros treatment with the intention of curing the disease by detecting it at an early stage is preferable to techniques that do not facilitate rapid detection of the disease.

## 1.8 Conclusion

Wildlife can act as reservoirs of *M.bovis* for domestic animals and have to be examined for this pathogen. If wildlife is to be protected consideration should be given to using tests that have the required levels of sensitivity and specificity for obtaining accurate data on the prevalence of *M. bovis* in free-ranging wildlife (De Lisle et.al; 2002).

Control of TB based on tests and slaughter principles although very successful for cattle has a limited role in free-ranging wildlife unless improved diagnostic tests are developed. Even if effective tests become available, accessing sufficiently large numbers of animals for testing and detecting the disease at a low prevalence will remain a formidable task.

A diagnostic test which could be performed over 24 hours would be very useful as this would be rapid enough for a wild animal to be caught and held until the results of the test are known. *In vitro* cell-mediated tests for wildlife definitely has the advantage of requiring only one handling of the animal as well as detecting mediated immune responses that are likely to predominate in subclinical cases of TB.

### 1.9 Objectives of the thesis

The overall goal of the project was to develop a diagnostic assay based on the presence of the cytokine, interferon-gamma (IFN $\gamma$ ) in order to diagnose TB in elephants and rhinoceros. This assay would be useful in identifying infected populations as well as infected individuals. It is a valuable tool for re-allocation and breeding strategies and ultimately potentially in eradication of infected animals.

The specific objectives were:

1. The cloning and sequencing of the gene IFN $\gamma$  for each species.
2. The production of recombinant IFN $\gamma$  products for each species.
3. The production of monoclonal antibodies against the expressed gene for each species.
4. The set up of an ELISA to determine the IFN $\gamma$  assay conditions.
5. To test the assay on native IFN $\gamma$  containing samples of elephants and rhinoceros.

### 1.10 Time frame

The study period ran from September 2001 to May 2003. The majority of the research was performed at the University Utrecht, in The Netherlands. Remaining work regarding the sequencing of the IFN $\gamma$  genes was performed at the Department of Tropical Diseases at the University of Pretoria, Onderstepoort, South Africa.

## **Chapter Two**

### **Cloning and Sequencing of Rhinoceros and Elephant Interferon-gamma (IFN $\gamma$ )**

#### 2.1. Introduction

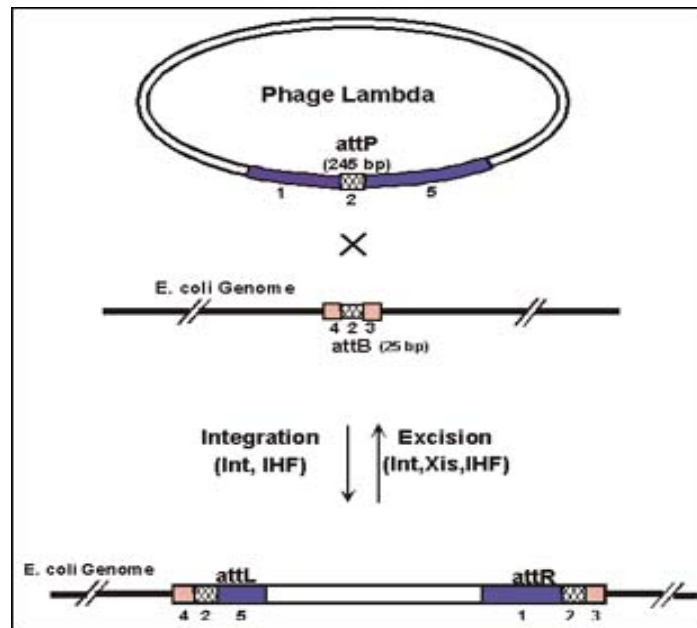
In order to produce recombinant rhinoceros and elephant IFN $\gamma$ , the gene of interest had to be isolated and cloned into an expression vector. RNA from responding T-cells that were obtained after PBMC stimulation were isolated and used to synthesize cDNA. This cDNA was used as the template in amplification reactions with IFN $\gamma$  specific primers, in order to select for the gene of interest. The desired PCR product that was obtained from the cDNA amplification was used as the template for the GATEWAY (GW) PCR as described in 2.5.5.

In order to facilitate the GW cloning technique later on (Refer to 2.1.1, Chapter 3) the GW PCR was used to incorporate GW cloning sites to the gene of interest. The GW PCR was performed using GW primers and the product of the PCR was used in a BP reaction (Figure 2.2). This reaction allowed the cloning of the gene into the donor vector, pDONR. The vector was then used to transfer the gene into an expression vector, pET15bGW (Figure 2.4), by means of an LR reaction (Figure 2.3).

#### 2.1.1 GATEWAY (GW) Cloning Technology

GATEWAY Cloning Technology (Invitrogen) is a universal system for cloning and sub-cloning DNA fragments. The recombination reactions of the GW Cloning Technology are based on the site-specific recombination reactions of bacteriophage  $\lambda$  with the *E.coli* genome. Recombination between the phage attachment (*attP*) and bacterial attachment (*attB*) sites by a specific set of enzymes (the phage  $\lambda$  Integrase and the *E.coli* Integration Host Factor (IHF)) results in integration of the circular  $\lambda$  phage into the *E.coli* genome (Figure 2.1).

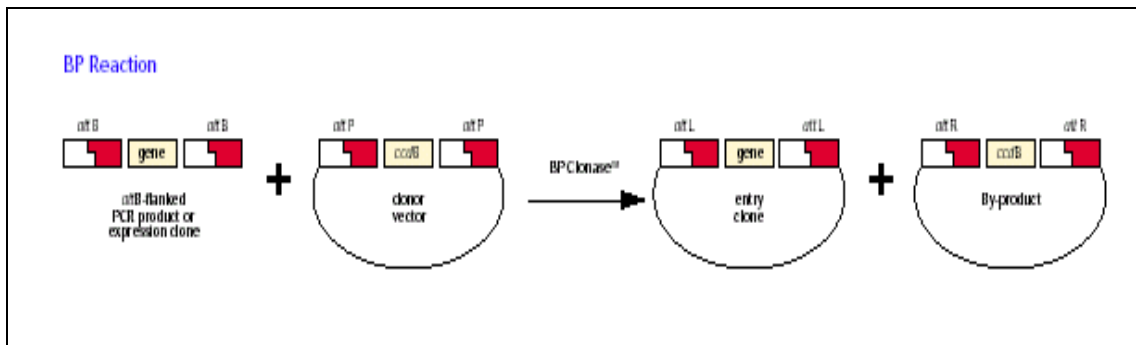




**Figure 2.1** Bacteriophage Lambda ( $\lambda$ ) Recombination in *E.coli* (Invitrogen).

The BP CLONASE Enzyme Mix of the GW-cloning system consists of the enzymes involved in this process. It is used to clone PCR fragments containing *attB* extensions into vector pDONR, which contains *attP* sequences (Figure 2.2). Due to the recombination between the *attB* and *attP* sequences mediated by the BP CLONASE, the *ccdB* gene of pDONR is replaced by the PCR fragment. The vector that is formed is referred to as the Entry Clone (Figure 2.2).

The LR CLONASE Enzyme Mix contains the enzymes that in the normal phage  $\lambda$  life cycle establish the recombination between the left attachment (*attL*) and right attachments (*attR*) sites of the lysogenic form of bacteriophage  $\lambda$  (the phage  $\lambda$  Integrase and Excisionase (Xis) and *E.coli* IHF (Figure 2.1). As a consequence, phage  $\lambda$  is released from the bacterial chromosome. In the GW-system this (LR) reaction is used to transfer genes cloned into pDONR (i.e. entry clones) into a destination vector. The resulting vector is referred to as an expression clone (Figure 2.3). The *att*-sequences used in the GW-system contain some changes in comparison with the wild-type *att*-sequences that make the system more efficient and allow cloning of the genes in a fixed orientation.

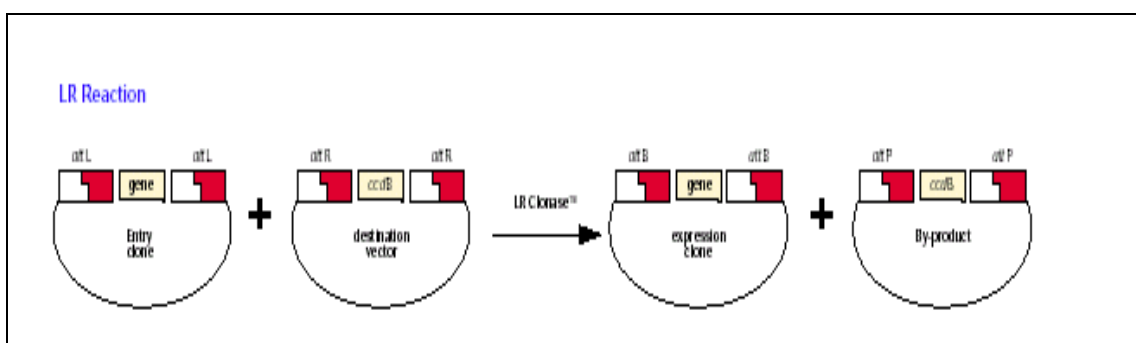


**Figure 2.2** Gateway BP reaction: recombination of a PCR fragment containing *attB* extensions with *attP* substrate (donor vector) results in an entry clone containing *attL* sequences.

Following transformation with Entry or Expression clones, bacteria are selected on plates containing the appropriate antibiotics (kanamycin for entry clones and ampicillin for expression clones). The *ccdB* gene, present in pDONR and in destination vectors, encodes a toxic protein. Therefore only bacteria that have taken up vector in which the *ccdB* gene has been replaced by the gene of interest will establish colonies. This greatly increases the percentage of correct clones.

The gene of interest was transferred from the entry vector, pDONR to a destination vector, pET15bGW, creating an expression clone, which introduces the second pathway to the GATEWAY cloning technique (Figure 2.3).

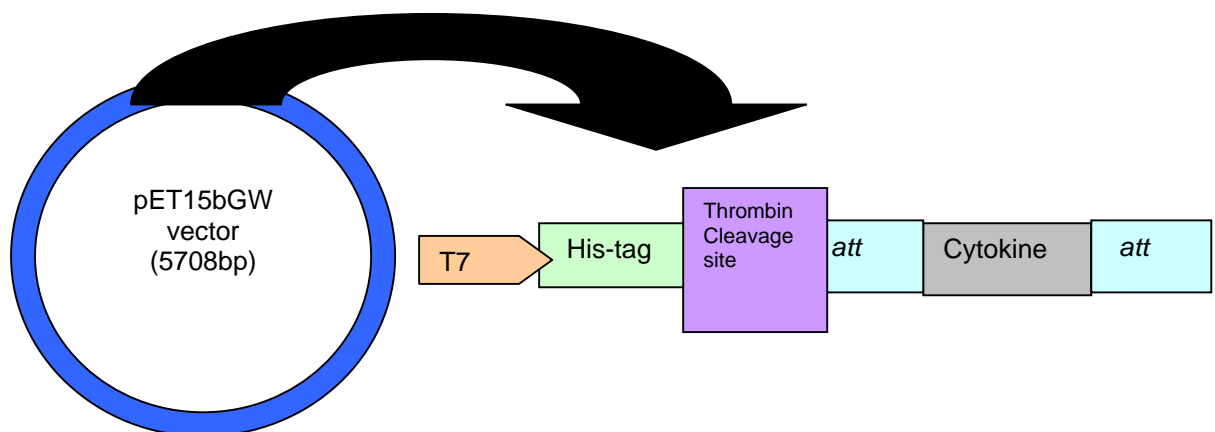
The second pathway is the LR reaction. cDNA/DNA sequences flanked by the *attL* sites were transferred by recombination sites from an entry clone into a destination vector, which contains *attR* sites.



**Figure 2.3** Gateway LR reaction: recombination of an *attL* substrate (entry clone) with an *attR* substrate (destination vector) results in formation of an expression clone containing *attB* sequences.

During this recombination the destination vector conveys some functionally useful elements, e.g., promoter, fusion tag, / selection marker to the final recombination product. The resulting molecule is called an expression clone. It is a sub-clone of the starting DNA sequence, correctly positioned in a new vector backbone. Selection of positive clones occurred on ampicillin plates after transformation into DH5 $\alpha$  cells. Negative selection against the original destination vector and the by-product is a result of the lethal *ccdB* gene.

Recombination of the gene-of-interest by the LR reaction (Figure 2.2) into destination vector pET15bGW result in an expression clone in which the gene of interest is under control of a T7 promoter and in-frame with an N-terminal his6-tag, the *attB* sequence and a sequence encoding the thrombin cleavage site (Figure 2.4).



**Figure 2.4** Schematic representation of pET15bGW. The plasmid has a T7 promoter, his-tag region, GW recombination site - *att* and the gene of interest will be cloned within the *att* sites.

## 2.2 Materials and Methods

### 2.2.1 PBMC Stimulation

#### Sample collection

Blood samples from elephant were obtained from the Amersfoort Zoo, and the rhinoceros blood sample was obtained from Beekse Bergen a safari park in Tilburg, The Netherlands.

#### PBMC stimulation

The blood was collected in EDTA tubes to prevent clotting. The blood was transferred to 50ml disposable tubes to which an equal volume of RPMI medium (Roswell Park Memorial Institute) was added. Ficoll (1.078) was then added under the blood medium. This was followed by a centrifugation step at 1800rpm for 25 mins. Three distinct layers were formed during centrifugation. The interphase containing the mononuclear white blood cells was removed using a pipette and transferred to another tube. The cells were washed in wash medium (495ml RPMI + 5ml Penicillin (5000U/ml)/Streptomycin (5000µg/ml) and the cell suspension was centrifuged once again at 1800rpm for 25 mins. The medium was discarded and the pellet was washed with complete medium (RPMI, penicillin(5000U/ml)/streptomycin(5000µg/ml), 200mM L-glutamin, heat inactivated fetal calf serum (10%), and β-mercaptoethanol (200µl). From the final cell suspension in 10ml a 5µl sample taken to do a cell count. The cell suspension was adjusted to 10<sup>6</sup> cells/ml. In a 75cm<sup>2</sup> tissue culture flask 10ml of these cells were added to Con A at a concentration of 5µg/ml to stimulate cells for T-cell proliferation. The flask was incubated at 37°C for 21hrs.

### 2.2.2 mRNA isolation and cDNA synthesis

After completion of the stimulation of PBMC with Con A the cells were harvested and the RNA from the cells was ready to be isolated. The cells were resuspended using 1ml Trizol (Gibco BRL). To this chloroform/isoamylalcohol (24:1), was added and the sample was vortexed and left on ice for 15 mins. The sample was centrifuged at 1800 rpm for 15 mins at 4°C. After centrifugation the RNA containing upper phase was transferred to a clean tube containing isopropanol. After incubation at -20°C for 45 mins the sample was centrifuged again at the same conditions so that the supernatant could be removed completely. The pellet that forms was dissolved in 100µl of distilled water + 0.1V 3M sodium acetate (NaAc) + 2.5V 100% ethanol

(EtOH). After an overnight incubation at  $-20^{\circ}\text{C}$  the pellet was washed in 1ml 70% ethanol and then dried. The pellet was dissolved in  $11\mu\text{l}$  RNase free distilled water and stored at  $-20^{\circ}\text{C}$ . The amount of RNA isolated was measured using a spectrophotometer at wavelength 260/280nm. To synthesise cDNA a solution of  $1\mu\text{g}$  RNA/ $10\mu\text{l}$  distilled water was made to which oligo-dT was added and incubated at  $56^{\circ}\text{C}$  for 10 mins before placing on ice for 15 mins. After the incubation a solution of 5xRT buffer [first strand], 4mM dNTP, 100mM dTT and  $200\text{U}/\mu\text{l}$  reverse transcriptase was added to  $11\mu\text{l}$  RNA + oligo-dT. The sample was mixed and then incubated at  $42^{\circ}\text{C}$  for 1.5 hrs. Finally,  $100\mu\text{l}$  of distilled water was added and stored at  $-20^{\circ}\text{C}$  until further use.

### 2.2.3 PCR elephant cDNA

#### Primers

Since the sequence of the elephant and rhinoceros IFN $\gamma$  were not yet known, primers used were selected based on sequence homology between known gene sequences of other mammals and their phylogenetic relationship with the elephant and rhinoceros. For the reverse primer a sequence was selected that was conserved between cat, dog, horse, sheep, cow and human (Table 2.1). Dog IFN $\gamma$  reverse primer and the forward primers as illustrated in Table 2.1 were used.

#### Reaction mixture

Each reaction mixture contains template cDNA ( $1\mu\text{l}$ ), 1.25mM  $\text{MgCl}_2$ , 10x PCR buffer (50mMKCl, 10mM Tris HCl [pH9.0], 1.55[vol/vol] TritonX-100), 10pmol of each forward and reverse primer and 1U of Taq DNA polymerase (Promega), in a final volume of  $20\mu\text{l}$ .

#### PCR cycles

The reaction tubes were placed in a BioRad Thermal I Cycler. The following conditions were used: Heat denaturation at  $95^{\circ}\text{C}$  for 5 mins, followed by 35 cycles consisting of heat denaturation at  $95^{\circ}\text{C}$  for 30 secs, primer annealing at a range of 4 different temperatures ( $65^{\circ}\text{C}$ ,  $59.3^{\circ}\text{C}$ ,  $55.5^{\circ}\text{C}$ ,  $50^{\circ}\text{C}$ ) for 45 secs and primer extension at  $72^{\circ}\text{C}$  for 60 secs. After the last cycle the programme included a DNA extension at  $72^{\circ}\text{C}$  for 10 mins to allow complete synthesis of all strands.

2.2.4 PCR rhinoceros cDNA

Primers

Primers were selected on the same basis as discussed in 2.2.3. In selecting the forward primer for the rhinoceros sample, however, only one forward primer was used. The forward primer selected for this sample was horse IFN $\gamma$  as the horse is most related to the rhinoceros.

Reaction mixture

The reaction mixture contained 10x PCR buffer (100mM Tris HCl [pH8.85], 250mM KCl and 50mM (NH<sub>4</sub>)<sub>2</sub>SO<sub>4</sub>), 25mM MgSO<sub>4</sub>, 4mM dNTPs, 1 $\mu$ l of cDNA, 10 $\mu$ mol of dog IFN $\gamma$  reverse primer and the horse IFN $\gamma$  forward primer and 0.25 $\mu$ l of *Pwo* DNA polymerase (Roche) per reaction.

PCR cycles

The PCR conditions for thermal cycling were the same with the exception that annealing temperatures ranged from 56°C, 58°C, 61.1°C and 64.7°C. In addition to *Pwo*, Taq DNA polymerase was also used.

Controls

Control reaction mixtures containing distilled water and all other reagents but no template was amplified along with the test samples throughout the amplification reaction. Positive controls included glyceraldehyde-3-phosphate dehydrogenase (G3pDH), a household enzyme and horse IFN $\gamma$ -pDONR plasmid. Amplified products were visualized on 1% agarose gels in 0.5x TBE (Tris borate, boric acid and EDTA [pH8.5]). A *Pst* $\lambda$  marker was included on each gel as a molecular size standard.

**Table 2.1** Primers used for the amplification of elephant cDNA

Primers	Sequence
<b>Reverse Primer:</b> Dog IFN $\gamma$	5' AATTCAAATATTGCAGGCAGG 3'
<b>Forward Primers:</b> Cow IFN $\gamma$ Dog IFN $\gamma$ Horse IFN $\gamma$ Pig IFN $\gamma$ Sheep IFN $\gamma$	5' CAGGGCCAATTTTTTAGAGAAATAG 3' 5' CAGGCCATGTTTTTAAAGAAATA 3' 5' CAGGCCGCGTTTTTAAAGAAATA 3' 5' CAGGCGCCCTTTTTTAAAGAAATAAC 3' 5' CAGGGCCATTTTTTAAAGAAATA 3'

### 2.2.5 GATEWAY PCR

For the GW PCR 2 different protocols were applied for the 2 species. In this PCR the amplified PCR product obtained in 2.2.3 and 2.2.4 was used as the template.

#### Primers

Gateway primers (Invitrogen) were used for the forward and reverse reactions.

#### Reaction Mixtures

##### Elephant amplified cDNA

For the elephant sample two reaction mixtures were used. The first reaction mixture contained 1xPCR buffer (50mM KCl, 10mM Tris-HCl [pH9.0], 1.5% [vol/vol] TritonX-100), 1.5mM MgCl<sub>2</sub>, each deoxynucleoside triphosphate (dNTP) at a concentration of 0.1mM, 4mM of each Gateway primer (Invitrogen) and 1U Taq DNA polymerase (Promega) per 50µl reaction mixture. The second reaction mixture was made up using *Pfu* Turbo (Hot start) DNA polymerase (Stratagene). The sample volume was 20µl. The second reaction mixture contained the same amounts of the dNTPs and primers as the first reaction mix.

##### Rhinoceros amplified cDNA

The reaction mixture used for this sample contained: 10xPCR buffer (100mM Tris HCl [pH 8.85], 250mM KCl and 50mM (NH<sub>4</sub>)<sub>2</sub>SO<sub>4</sub>) [1/10<sup>th</sup> of the final reaction volume was used], 25mM MgSO<sub>4</sub>, 4mM dNTPs, 1µl of amplified cDNA (PCR product), 4uM of each Gateway primer (Invitrogen) and 0.25µl of *Pwo* DNA polymerase (Roche) per reaction. The PCR conditions were the same as for the elephant IFN $\gamma$  except that the annealing temperatures were 56°C and 58°C.

#### Controls

Control reaction mixtures containing distilled water and all other reagents but no template was amplified along with the test samples throughout the amplification reaction. Positive controls included were horse IFN $\gamma$  plasmid and dog IFN $\gamma$  plasmid. PCR products were visualized on agarose gels in 1xTBE (89mM Tris-borate, 89mM boric acid, 2mM EDTA, pH8.5). A *Pst* $\lambda$  marker was included on each gel as a molecular size standard.

#### PCR cycles

The reaction tubes were placed in a Bio Rad Thermal I Cycler. A hot start protocol was performed. The buffer and enzymes were mixed together and added at 95°C except for the samples for which *Pfu* Turbo was used. The following conditions were

used: heat denaturation at 95°C for 5 mins, followed by 35 cycles consisting of heat denaturation at 95°C for 30 secs, primer annealing was performed at different temperatures for different samples (56°C, 58.7°C, 61.1°C and 64°C for the elephant sample and 56°C and 58°C for the rhinoceros sample). DNA extension was performed at 72°C for 45 secs. After the last cycle the samples were kept at 72°C for 10 mins to complete synthesis of all strands.

#### 2.2.6 BP reaction (Invitrogen)

For the BP reaction (Figure 2.2) the BP CLONASE™ Enzyme Mix, BP CLONASE™ reaction buffer, the pDONR vector and the PCR product were used. The gene of interest flanked by the 25bp *attB* sites, serves as the substrate. The positive control was the pEXP7 vector. From the reaction mixture, consisting of the BP buffer, BP Clonase enzyme and pDONR, 2µl is added to 2µl PCR product. After the overnight BP reaction 1µl of Proteinase K was added to stop the reaction. This was allowed to stand at 37°C for 10 mins before the DNA was transformed to DH5α competent cells.

#### 2.2.7 Transformation in DH5α competent cells

After Proteinase K treatment 2µl of the overnight BP reaction was added to 50µl chemically competent DH5α cells (Invitrogen, Library efficiency). These steps are carried out on ice. Following the incubation on ice for 30 mins the reactions were given a heat shock treatment at 42°C for 45 secs and placed once again on ice for 2 mins. Subsequently, 450µl of SOC medium [Bacto-tryptone, Bacto-yeast extract, NaCl, KCl, Glucose] was added to each sample and left to incubate at 37°C in the shake incubator for 45 mins to an hour. After the incubation steps the samples were centrifuged at 3000 rpm for 5 mins. From the supernatant 250µl was discarded and the remainder was used to resuspend the pellet and the contents were spread onto LB agar plates prepared with kanamycin. Plates were incubated at 37°C overnight.

#### 2.2.8 Screening colonies

##### Primers

For the elephant sample both the forward and reverse primers of the dog IFNγ were used. The sample volume was 20µl.



#### Reaction mixture

Colonies were randomly selected to determine which clones were positive for the plasmid containing the gene of interest. The reaction mixture used in the PCR steps contained 2µl of 10xPCR buffer (50mM KCl, 100mM TrisHCl-pH9.0, 1.5%[vol/vol] TritonX-100, 25mM MgCl<sub>2</sub>) for each 20µl reaction mixture, 4mM dNTPs, 1U Taq DNA polymerase (Promega), 0.8µl of a 10pmol concentration of horse IFN $\gamma$  for the forward reaction and dog IFN $\gamma$  for the reverse reaction (for the rhino cDNA sample).

#### PCR cycles

The reaction tubes were placed in a Bio-Rad I-Cycler. The cycle profile used: heat denaturation at 94°C for 5 mins, followed by 35 cycles consisting of heat denaturation at 94°C for 1 min, primer annealing at 58°C for 1 min and DNA extension at 72°C for 1 min. The amplicons were resolved on a 2% agarose gel in 1x TBE (89mM Tris-borate, 89mM Boric acid, 2mM EDTA pH8.3) and visualized by UV-induced fluorescence. A DNA marker consisting of phage  $\lambda$  DNA digested with *Pst* ( $Pst\lambda$ ) was included on each gel as a molecular size standard.

#### 2.2.9 Plasmid extraction

To isolate the plasmids, the Concert™ Rapid Plasmid-Miniprep System (Life Technologies – Gibco BRL) was used. The centrifugation protocol was followed according to the instructions of the manufacturer. The plasmids that were isolated were labelled and stored at –20°C for use in the LR reaction as described in 2.2.10.

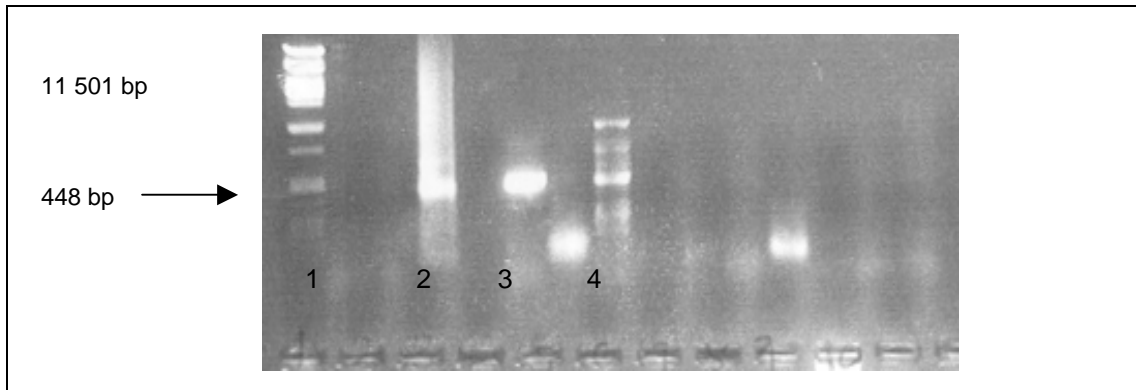
#### 2.2.10 LR reaction (Invitrogen)

For the LR reaction (Figure 2.3) we require the LR Clonase™ Enzyme mix, LR Clonase™ Reaction buffer the pET15bGW vector (i.e. the *attR* sites containing destination vector) and the purified pDONR plasmid containing our gene of interest flanked by the *attL* sites (ie the entry vector). The plasmid pENTR was used as the positive control. A total of 2µl of the reaction mix consisting of 3µl of LR buffer, 3µl of LR Clonase enzyme and 1.5µl of the pET15bGW (800ng/µl) was added to 2µl of plasmid. Samples were incubated at 25°C overnight and the following day the transformation was carried out in library efficient DH5 $\alpha$  competent cells as described in 2.2.7. Colonies were screened using PCR as described in 2.2.8.

## 2.3 Results

### Elephant and Rhinoceros cDNA amplification

Figures 2.5 and 2.6 show the results obtained from the different annealing temperatures used during the amplification of the elephant cDNA and rhinoceros cDNA respectively.



**Figure 2.5** Elephant cDNA amplification results.

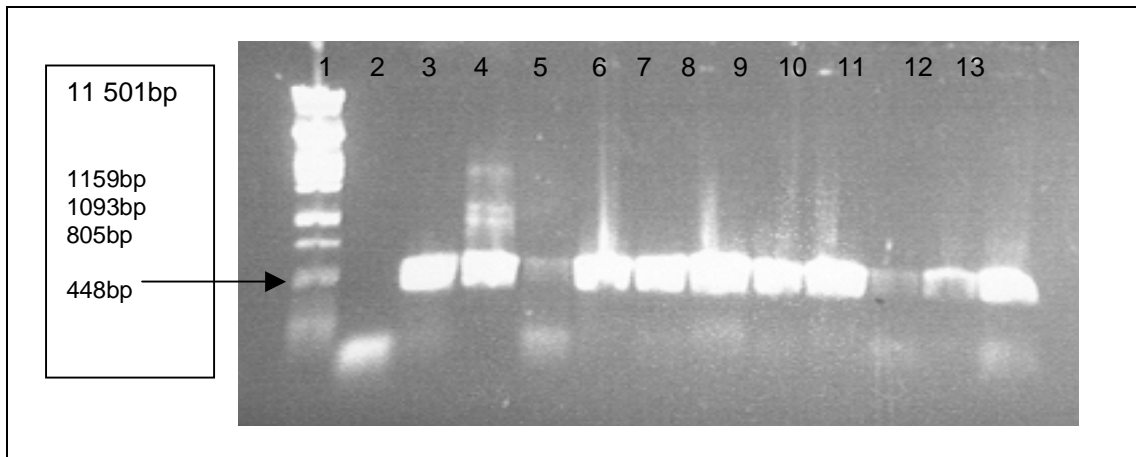
Analysis of PCR products on agarose gel: Lane 1: *Pst*  $\lambda$  standard, Lane 2: G3pDH positive control, Lane 3: PCR product obtained at an annealing temperature of 62°C and using Taq DNA polymerase, Lane 4: PCR product obtained at an annealing temperature of 62°C using proof reading enzyme *Pfu* Turbo. Refer to Table 2.2 for the reference to the products in the respective lanes.

Table 2.2 shows at which temperatures positive results were obtained for the elephant cDNA amplification with the dog IFN $\gamma$  primers. A range of four different annealing temperatures were used and three DNA polymerase enzymes were used. Table 2.3 serves as a key to Figure 2.6.

**Table 2.2** Results of the elephant cDNA amplification using a range of annealing temperatures and polymerase enzymes

	Annealing temperatures			
<b>DNA polymerase</b>	62°C	66°C	68°C	70°C
<b>Taq</b>	Positive product Lane 3	-	-	-
<b>Pfu Turbo</b>	Positive product Lane 4	-	-	-
<b>Pwo</b>	-	-	-	-

The results of the amplification of the elephant cDNA was analysed on agarose gel. It showed that the expected positive product was obtained at an annealing temperature of 62°C using two different polymerase enzymes. The size of the product was 448bp. (Refer to Figure 2.5 and Table 2.2).



**Figure 2.6** Rhinoceros cDNA amplification results.

Analysis of the PCR products on agarose gel: Lane 1: Marker, Lane 2&5: negative controls, Lane 3: G3pDH control, Lane 4: positive control (Horse IFN $\gamma$ ), Lane 6-13: Refer to Table 2.3 for reference.

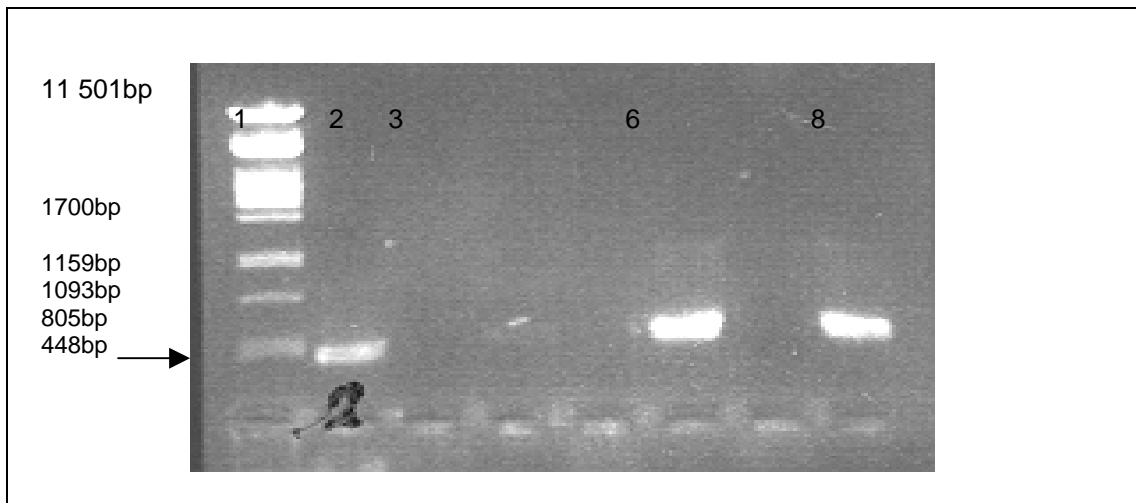
The PCR products obtained from the amplification of the rhinoceros cDNA was analysed on agarose gel and the expected product of 448bp was obtained under all the conditions tested except at an annealing temperature of 64°C using Taq polymerase. The results obtained in Figure 2.6 are summarised in Table 2.3. Table 2.3 serve as keys to the figures above respectively indicating at which annealing temperatures and polymerase enzymes expected PCR products were obtained.

**Table 2.3** Results of the PCR products obtained after the amplification of rhinoceros cDNA using four different annealing temperatures and two different DNA polymerase enzymes.

Lanes corresponding on the gel	Result
1. <i>Pst</i> λ marker	
2. Negative control - no template but G3pDH primers were used.	No product obtained
3. Positive control - G3pDH at 56°C.	Expected PCR product obtained
4. Positive control - G3pDH at 56°C.	Expected PCR product obtained
5. Negative control – no template but horse IFNγ primers were used – 56°C.	No Product obtained
6. <i>Pwo</i> polymerase at annealing temperature of 56°C.	Expected PCR product obtained
7. Taq polymerase at annealing temperature of 56°C.	Expected PCR product obtained
8. Taq polymerase at annealing temperature of 58.7°C.	Expected PCR product obtained
9. Taq polymerase at annealing temperature of 58.7°C.	Expected PCR product obtained
10. <i>Pwo</i> polymerase at annealing temperature of 61.1°C.	Expected PCR product obtained
11. Taq polymerase at annealing temperature of 61.1°C.	Expected PCR product obtained
12. <i>Pwo</i> polymerase at annealing temperature of 64.7°C.	Expected PCR product obtained
13. Taq polymerase at annealing temperature of 64.7°C.	Expected PCR product not obtained

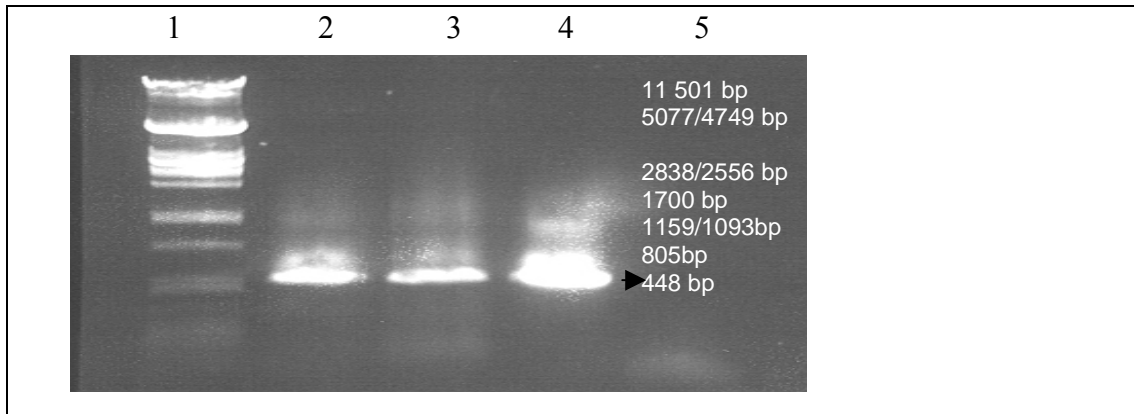
Gateway PCR

The following two Figures 2.7 and 2.8 show the results obtained after the GW extension sites were introduced to the gene of interest during the GW PCR. Figure 2.7 shows the results of the elephant sample and Figure 2.6 shows the PCR results of the rhinoceros sample.



**Figure 2.7** Analysis of the Gateway PCR results showing the expected positive results obtained in lanes 6 and lane 8. Lane 1: *Pst*I marker, Lane 2: positive control – G3pDH household enzyme , Lane 3: negative control (water), Lane 6: elephant IFN $\gamma$  using *Pfu* Turbo DNA polymerase at an annealing temperature of 60°C, Lane 8: elephant IFN $\gamma$  using *Pfu* Turbo DNA polymerase at an annealing temperature of 58°C. (Lanes 4, 5 and 7 were not loaded with any samples).

As mentioned the purpose of the GW PCR was to introduce *att* recombination sites to the gene of interest so as to facilitate the GW cloning procedure. The results shown in Figure 2.7 show us that the GW recombination sites was successfully introduced to either side of the gene of interest.



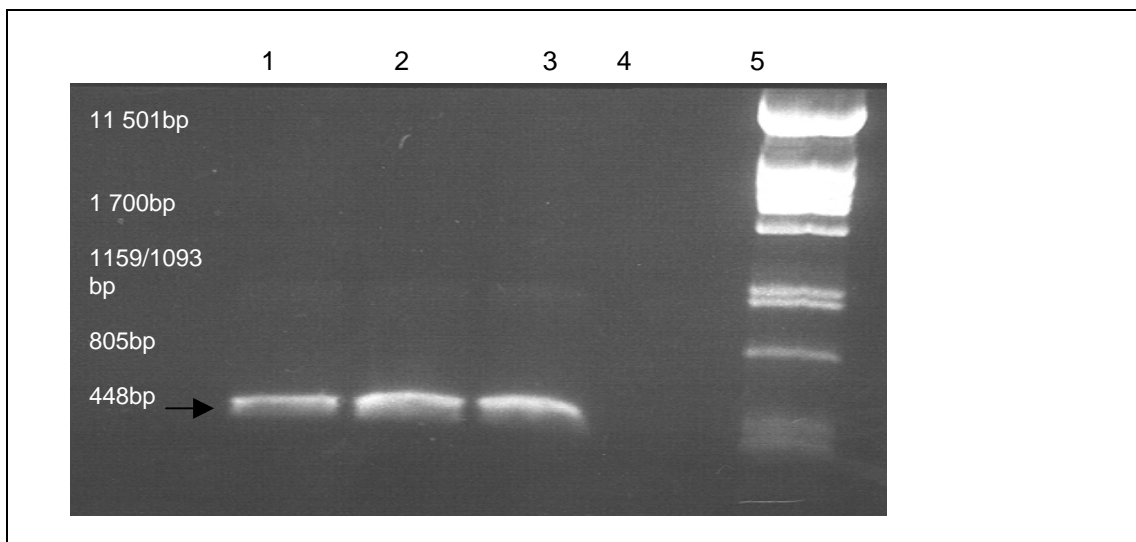
**Figure 2.8:** Analysis of the PCR results obtained from the GW PCR of the rhinoceros IFN $\gamma$  samples shows positive results in lanes 2 and 3 using *Pwo* DNA polymerase at annealing temperatures of 56°C and 58°C respectively. Lane 1: *Pst* $\lambda$  marker, Lane 4: positive control (horse IFN $\gamma$  pDONR plasmid), Lane 5: negative control (water).

The Gateway PCR conditions for the rhinoceros amplified cDNA differed from the PCR conditions used for the elephant cDNA sample. In the first attempt *Pwo* DNA polymerase was used at an annealing temperature of 61°C and no results were obtained. The annealing temperatures were changed to 56°C and 58°C. This change resulted in PCR products of the expected size. For the elephant amplified cDNA samples, 3 PCR attempts were made before the products were obtained. The reason for this was that the PCR conditions regarding the annealing temperatures and polymerase enzymes used differed and were not optimized. Therefore there were many attempts using different conditions to determine which one would give the expected results. In the first PCR an annealing temperature of 62°C was used. *Taq* DNA polymerase was used and a 35 cycle PCR was performed. No positive results were obtained and in addition the controls also failed to show up during the analysis. This PCR product was subjected to a further 7 cycles at the same annealing temperature. When the products were analyzed using agarose gel electrophoresis still no products were obtained. Thus indicating that there were errors made during the set up of the PCR and a possibility that the annealing temperatures were not the ideal ones to use. Since an optimum annealing temperature was not determined at this point a range of four different annealing temperatures were used and a gradient PCR was set up. Also included were the uses of two different polymerase enzymes, viz; *Taq*

DNA polymerase and *Pfu* Turbo hot start. DNA polymerase. The latter has a proof reading function. With this change we obtained the desired PCR products at an annealing temperatures of 58°C and 61°C using *Pfu* Turbo Hot start.

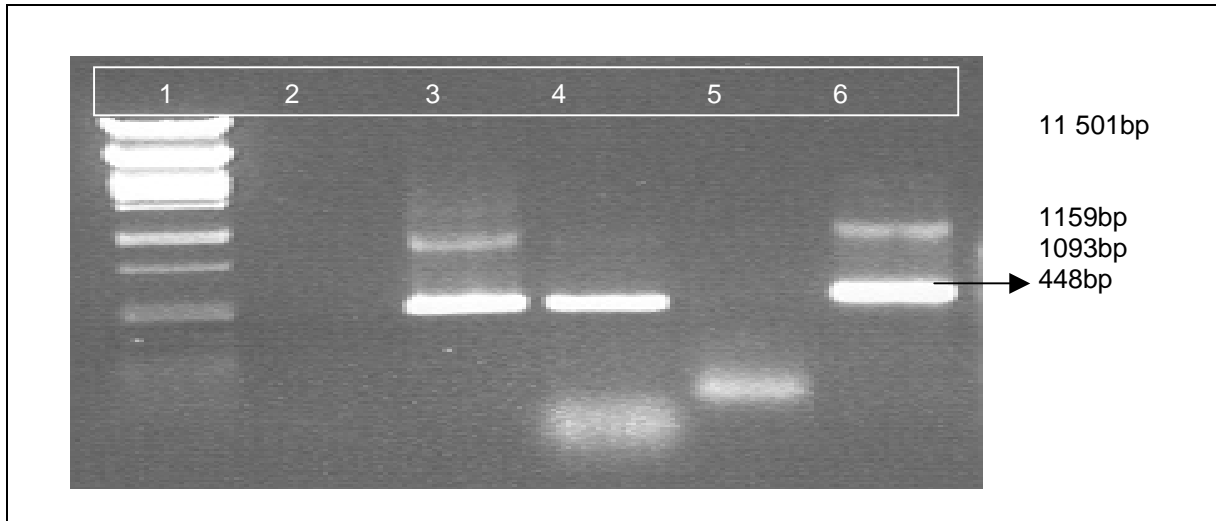
#### Screening colonies for pDONR transformants

Transformations were carried out in DH5 $\alpha$  competent cells. Selection was done on kanamycin resistant LB agar plates. Clones were screened using PCR as described in 2.2.8. The results are shown in Figures 2.9 and 2.10 for the elephant and rhinoceros samples respectively.



**Figure 2.9** Analysis of the colonies selected for the screening of pDONR containing the gene of interest (Elephant IFN $\gamma$  + recombination sites). Lane 1: clone 1 elephant IFN $\gamma$  pDONR, Lane 2: positive control (dog IFN $\gamma$ ), Lane 3: clone 2 elephant IFN $\gamma$  pDONR, Lane 4: negative control (no template) Lane 5: *Pst* $\lambda$  marker.



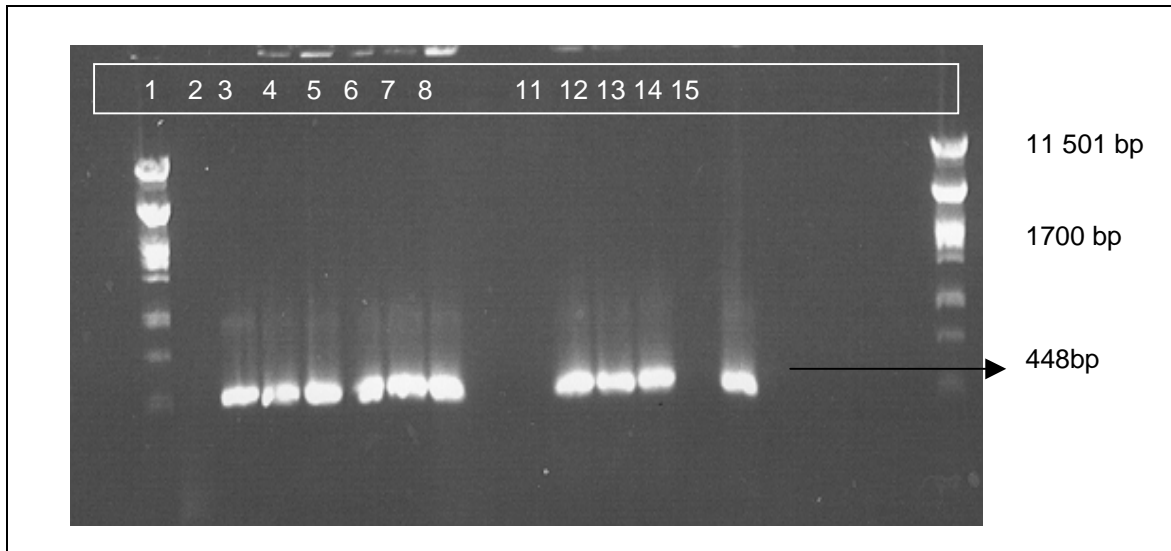


**Figure 2.10** Analysis of the colonies selected for the screening of pDONR containing the gene of interest (Rhinoceros IFN $\gamma$  + the recombinant sites). Lane 1: *Pst*  $\lambda$  marker, Lane 2: negative control (no template), Lane 3: positive control (horse IFN $\gamma$  plasmid), Lane 4: clone 1 rhinoceros IFN $\gamma$  pDONR, Lane 5: clone 2 rhinoceros IFN $\gamma$ , Lane 6: clone 3 rhinoceros IFN $\gamma$  pDONR.

To determine if indeed the clones obtained after transformation contained the gene of interest a PCR was performed and products were analyzed on agarose gels. The fragments obtained in lanes 1 and 3 (Figure 2.9) and in lanes 4 and 6 (Figure 2.10) were of the expected size of 448bp confirming that the gene of interest was successfully cloned into the pDONR vector.

#### LR reaction and transformations

Figure 2.10 shows the results of the rhinoceros and elephant IFN $\gamma$  clones screened after cloning into the pET15bGW vector during the LR reaction. The PCR protocol used for the screening of the pET15bGW transformants were the same as described in 2.2.8. The one change was the use of GW primers instead of the species specific primers used in the previous PCR.



**Figure 2.11** Analysis of the elephant IFN $\gamma$  and rhinoceros IFN $\gamma$  clones screened after cloning into the pET15bGW vector. Lane 1: *Pst*  $\lambda$  marker, Lane 2: negative control (water), Lane 3: positive control (dog IFN $\gamma$  pET15bGW vector), Lane 4-8: elephant IFN $\gamma$  pET15bGW clones 1 to 5 respectively, Lane 11-15: rhinoceros IFN $\gamma$  pET15bGW clones 1 to 5 respectively.

From the results obtained in Figure 2.11 it can be seen 100% percent of the elephant IFN $\gamma$  pET15bGW clones screened positive and 80% of the rhinoceros IFN $\gamma$  pET15bGW clones screened positive. Two clones of each species that was screened were selected and cultured overnight. Plasmids were extracted and purified. The purified samples were labelled and stored at  $-20^{\circ}\text{C}$  for use in transformations in BL21DE codon+ cells for expression purposes as described in Chapter 3.

## 2.4 Discussion

This chapter reports the strategies used to isolate and clone elephant IFN $\gamma$  and rhinoceros IFN $\gamma$ .

### 2.4.1 cDNA amplification

Since the sequence information of IFN $\gamma$  of these two species were not known the reverse primer was selected based on conservation between different mammals. For the forward primer there was no choice. What was required, however, was to have the sequence encoding the start of the mature protein. Therefore a selection of forward primers that were used to clone the mature IFN $\gamma$  of other species was tested and the primers of species that were most related to the elephant and rhinoceros were selected. During the amplification steps a number of PCR reactions were performed on the elephant sample before a PCR fragment of the expected size was obtained. The initial PCR was set up using five different forward primers (Table 2.1) and an expected product was obtained with the use of dog IFN $\gamma$  forward and reverse primers at an annealing temperature of 65°C. Since the positive controls did not show up, the PCR was repeated. This time only the dog IFN $\gamma$  primers were used, however, the results were not repeatable. Another PCR with the forward and reverse dog IFN $\gamma$  primers was therefore set up where the PCR and conditions were adapted. Unlike the first PCR this reaction was initiated as a hotstart PCR and the annealing temperature range was increased to a range consisting of the following temperatures; 62°C, 66°C, 68°C and 70°C. Reactions were set up with three different polymerase enzymes. Pwo DNA polymerase as well as *Pfu* Turbo both have proof reading functions. *Pfu* Turbo hot start DNA polymerase is an antibody-inactivated enzyme. The DNA polymerase and 3'-5' exonuclease activities are fully neutralized until denaturation of the antibody by the initial PCR step (95°C for 5 min). Results obtained from the initial PCR for the amplification of elephant cDNA gave an indication to which conditions should be changed in order to optimize the PCR. The dog IFN $\gamma$  primers were the final primers that were use in this PCR.

PCR conditions were optimized during the amplification of elephant cDNA. These conditions served as a guide in making the changes regarding annealing temperatures for the amplification of rhinoceros cDNA. Therefore the amplification of the

rhinoceros cDNA did not require many trials before the positive products were obtained.

#### 2.4.2 Gateway PCR

GATEWAY (GW) cloning provides an efficient and rapid route to cloning which allows for the functional analysis of genes, protein expression and cloning or subcloning of DNA fragments. The ease with which the GW system works is provided by the *att* recombination sites used in combination with enzyme clones as described in 2.1.1. In addition the GW cloning technique provides an easy alternative to get the gene of interest expressed into vector systems due to the GW recombination sites. As mentioned previously this system is universal, all types of DNA fragments may be cloned (PCR fragments, cDNA or gDNA).

The GATEWAY (GW) cloning system has been successfully used by a number of researchers for various purposes. Coker and co-workers used the GW strategy for the development of *Rickettsia prowazekii* DNA vaccine in June of 2003. In March of 2003 Parr and Ball used the GW technology to generate an optimised donor/shuttle vector, pENTR-His-ccdB, which readily produced histidine-tagged recombinant proteins in multiple expression systems were used.

Using the GW PCR, GW cloning sites (*att* sites) were incorporated to both ends of the gene of interest successfully. This step will later facilitate the cloning of the gene into the pET15bGW expression vector (Figure 2.4).

#### 2.4.3 Screening for the pDONR transformants

PCR was used to screen the clones that contained the plasmid with the gene of interest. Different PCRs were set up for the two species. For the elephant IFN $\gamma$  pDONR clones the dog IFN $\gamma$  primers were used for both the reverse and forward reactions. *Pfu* Turbo and Taq DNA were the polymerase enzymes included in this reaction. For the rhinoceros IFN $\gamma$ , dog IFN $\gamma$  reverse primer and the horse IFN $\gamma$  forward primer were used. *Pwo* DNA polymerase was the enzyme included in this reaction. The PCR consisted of 35 cycles and an annealing temperature of 58°C. Unfortunately none of the clones that were screened were positive. The BP reaction

and the transformations were repeated and only Taq DNA polymerase was used in the PCR instead of the other two enzymes. All the clones that were screened were positive. The positive clones were cultured and plasmids purified, labeled and stored at  $-20^{\circ}\text{C}$  to be used for the LR reactions.

#### 2.4.4 Sequencing results

The purified pDONR plasmids of both the rhinoceros and elephant clones were sent for sequencing to the 24hr Baseclear Sequencing Centre, in Leiden. The data was processed and the sequences of both the rhinoceros and elephant IFN $\gamma$  both show homology to the horse IFN $\gamma$ . The sequence that was analysed was that of the mature protein region and not the complete coding sequence, which has yet to be determined. The results of the sequence obtained thus far are not included in here.

## **Chapter Three**

### **Expression and Purification of Rhinoceros and Elephant Interferon-gamma (IFN $\gamma$ )**

#### 3.1 Introduction

The aim of this part of the study was to express and purify rhinoceros and elephant IFN $\gamma$ . The recombinant proteins will be used in immunization of mice to produce monoclonal antibodies as described in Chapter 4.

To express recombinant elephant and rhinoceros IFN $\gamma$  protein, the GW expression system was used (Chapter 2). For this purpose the pET15bGW-IFN $\gamma$  vectors obtained in 2.2.10 were transformed in BL21DE codon+ cells. This strain of *E.coli* (Stratagene) is a general protein expression strain that lacks both the *Lon* protease and the *Omp T* protease, which can degrade proteins during purification. In addition this strain harbors the lambda lysogen DE3 that contains the gene for T7RNA polymerase under the control of the lac promoter. This lysogen produces T7 polymerase upon induction with IPTG. This enzyme transcribes from the T7 promoter on pET15bGW-IFN $\gamma$  (Figure 2.4) resulting in favourable production of the target protein. These BL21DE codon+ cells harbour a plasmid (codon+) that encodes for tRNA codons that are normally rare in *E.coli*, but commonly used in mammalian cells. Without this plasmid the expression of mammalian sequences containing these rare codons can be strongly reduced, due to the lack of the right tRNA. The (codon+)-plasmid confers chloramphenicol resistance to the bacteria. After transformation into BL21DE codon+ cells a small scale induction was performed to determine whether the recombinant proteins would be expressed. Upon obtaining positive results of the small scale induction, recombinant proteins could be produced on a larger scale.

Interferon-gamma (IFN $\gamma$ ) is a protein that is deposited in inclusion bodies. Inclusion body production is a common theme in recombinant technology and in most cases its formation is a consequence of high expression rates, regardless of the system/protein used (Lilie et. al; 1999). Since larger amounts of proteins were required-inclusion body production and renaturation provides an efficient route to meet these requirements. Inclusion bodies are very dense particles (Lilie et al; 1999) that form

part of the total protein lysate. They are pelleted by centrifugation and isolated via a series of wash steps. The recombinant proteins produced with the pET15bGW vector contains an affinity-tag consisting of 6 histidines. This tag has a strong affinity of metal ions like  $\text{Ni}^{2+}$ . Once the inclusion bodies are isolated they are solubilised, after which they are purified on columns bearing  $\text{Ni}^{2+}$  under denaturing conditions and thereafter refolded on the columns (Figure 3.1).

For the purification of his6-tagged proteins, immobilised metal affinity chromatography (IMAC) was applied.  $\text{Ni}^{2+}$  metal ions were immobilised on chelating sepharose fast flow (Amersham). On this matrix his6-tagged proteins will be selectively retained. During protein purification by IMAC various conditions were tested to ensure optimal purification. The first condition was the concentration of Imidazole during both loading and elution which serves as a competitor to the histidine for binding to the  $\text{Ni}^{2+}$  matrix. Another factor which had to be optimized during the purification step was the volume of  $\text{Ni}^{2+}$  matrix (Tables 3.2 and 3.3.).

Refolding is a sensitive method in which specific conditions like buffer composition, temperature, protein concentration and other factors depending on the method of renaturation to be used had to be optimised.

## 3.2 Materials and Methods

### 3.2.1 Transformation in BL21DE codon+ cells.

The pET15bGW vectors containing the gene of interest were transformed into BL21DE codon+ cells for expression purposes. Purified pET15bGW plasmid (2 $\mu$ l) obtained in 2.1.10 was added to 50 $\mu$ l of the competent cells and incubated on ice for 30 mins. The samples were heatshocked at 42°C for 45 secs and replaced on ice for 2 mins. The total volume was plated on LB agar plates, that contain ampicillin and chloramphenicol and incubated at 37°C overnight. To increase the efficiency of the transformation a second method was used to transform the cells. In this method, 2 $\mu$ l of a 1:10 dilution of  $\beta$ -mercaptoethanol was added to 100 $\mu$ l of competent cells before adding the purified DNA template to the cells. The rest of the protocol remained the same.

### 3.2.2 Small scale induction of elephant IFN $\gamma$ and rhinoceros IFN $\gamma$

Luria Broth (LB) medium was inoculated with a single colony grown overnight on LB agar containing chloramphenicol, ampicillin and glucose. The inoculated medium was incubated at 37°C in a shake incubator. Glucose was included in the overnight LB agar to prevent the activation of the lac operon. During the incubation of the liquid culture the optical density was measured at 1 hour intervals using a spectrophotometer. At an OD<sub>600</sub> of 0.6–0.8 IPTG (isopropyl- $\beta$ -D-thiogalactopyranoside), a synthetic inducer which rapidly stimulates the transcription of the lac operon structural genes, was added. An additional 4 hours of incubation at 37°C followed after the addition of IPTG. After this incubation, bacteria were spun down at 13000 rpm and resuspended in water so that the OD<sub>600</sub> would be 20. Subsequently an equal volume of 2x sample buffer was added and the samples were heated for 30 min. at 95°C before analysis by SDS-PAGE.

### 3.2.3 Production and isolation of inclusion bodies

LB agar plates containing ampicillin, chloramphenicol and glucose were inoculated with the required cultures and incubated at 37°C overnight. The next day 10ml of LB medium containing ampicillin and chloramphenicol was inoculated with the overnight culture. The small cultures were incubated for 1 hour at 37°C before being transferred to 1-liter flasks for batch culturing. The flasks were incubated at 37°C and the OD<sub>600</sub> was determined at regular intervals until a reading between 0.6 and 0.8 was reached. To each liter of culture 1ml of 1M IPTG was added. After 4 hours induction the induced culture was poured into 500ml buckets and centrifuged at 5100rpm for 15 mins. The pellet was resuspended in 50ml of Buffer B (20mM Tris HCl [pH8], 500mM NaCl, 0.1mg/ml of lysozyme), 25ml per 500ml culture. After the addition of Buffer B the samples were incubated at room temperature on a rotar for 30 mins. After this step 5ml Buffer C was added (100mM DTT, 50mM EDTA, 1% TritonX 100) to 50ml lysate. Dithiothertol (DTT) keeps all the cysteines in a reduced state and cleaves disulphide bonds formed during preparation (Lilie et al; 1998). The contents of the tube was mixed by inverting the tube several times before freezing at –20°C. Freezing and thawing of the sample was carried out three times. After the final thaw, 1500 $\mu$ l of 1M MgCl<sub>2</sub> and 2 $\mu$ l of beconase was added. The beconase hydrolyses the



nucleic acids and the sample was incubated at room temperature for 15 mins or until viscosity was reduced (it should take 30 to 60 mins before viscosity is completely reduced).

### *Isolation of inclusion bodies*

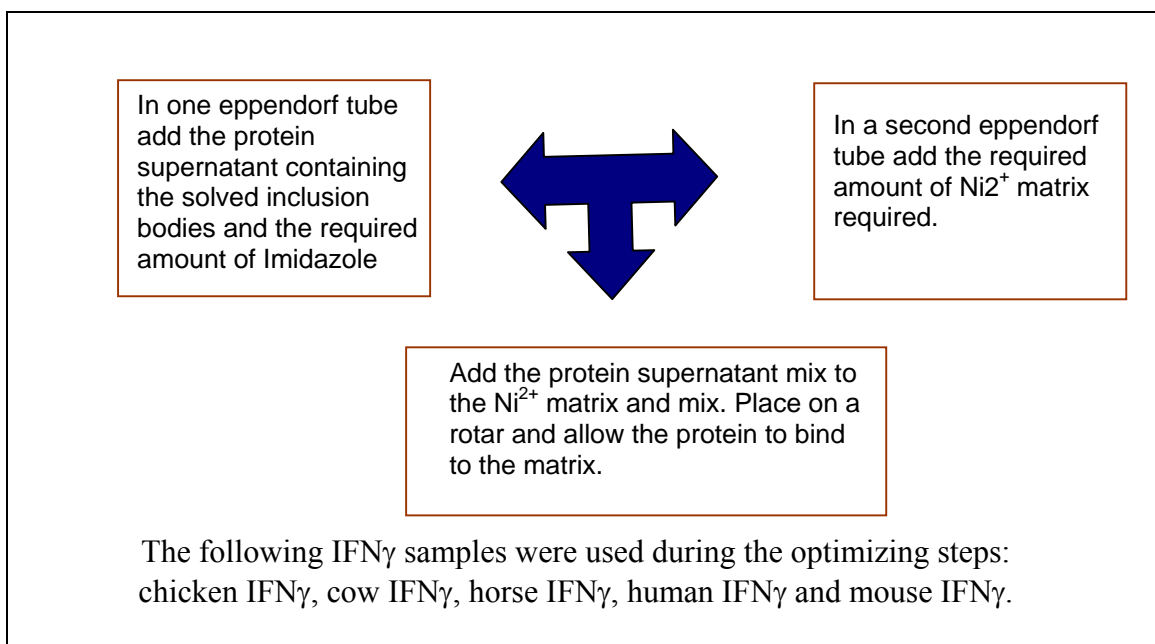
Once the viscosity was reduced the lysate was prepared for the isolation of the inclusion bodies. Samples were collected at various stages during the isolation steps. The lysate was centrifuged at 5100rpm for 15 mins. After centrifugation the supernatant represents the soluble fraction of the total protein lysate. A sample of this fraction was collected and the pellet was washed in Buffer-A1 (50mM Tris HCl, 500mM NaCl, 1% TritonX 100). The centrifugation step was repeated. The supernatant was discarded and the pellet was washed in Buffer A2 (20mM Tris [pH8], 50mM NaCl, 1% TritonX 100). These washing steps remove major contaminants of inclusion bodies like outer membrane proteins. After a final centrifugation step the pellet contained the insoluble fraction of the total protein and the supernatant was discarded. The pellet was resuspended in 10M urea, in Buffer A2. The urea solves the inclusion bodies. A sample of 20 $\mu$ l was collected of the total amount of inclusion bodies before centrifugation. After centrifugation a sample representing the total amount of solved inclusion bodies was taken. The samples collected at the different stages were analysed on SDS-PAGE. The solved inclusion bodies were ready for purification on the Ni<sup>2+</sup> matrix.

#### 3.2.4 Preparation of the Ni<sup>2+</sup>

Chelating Sepharose fast flow (Bio-Process™/Amersham) was charged with Ni<sup>2+</sup> ions. The sepharose beads were washed three times with ultra-distilled water. After the wash steps 0.1M NiSO<sub>4</sub> (3/2V of the Sepharose) was added to the beads. This was placed on a rotor for 10mins. Once the beads are charged they were washed once in ultra-distilled water. The next wash was done with Buffer A2 containing 10M urea. In the next step the matrix was resuspended in an equal volume of Buffer A2 containing 10M urea. The beads were ready for use.

3.2.5 Optimizing Imidazole concentration required for optimal protein purification on the Ni<sup>2+</sup> matrix.

In a separate eppendorf tube the solved inclusion bodies, Imidazole and the buffer were added. The amounts of the volumes for the reagents are included in Table 3.1. The tubes with the inclusion bodies, buffer and Imidazole were allowed to stand for a few minutes before adding it to other tubes containing Ni<sup>2+</sup> matrix. When the solved inclusion bodies were added to the matrix the samples were incubated at room temperature on a rotar for 10 mins.



**Figure 3.1** Flow diagram of the purification of proteins on the Ni<sup>2+</sup> matrix

**Table 3.1** Optimising the Imidazole concentration for protein purification on Ni<sup>2+</sup> matrix.

<b>Imidazole Concentration</b>				
	0mM	20mM	35mM	75mM
<b>Solved inclusion bodies</b>	500µl	500µl	500µl	500µl
<b>3M stock solution of Imidazole</b>	0µl	6.67µl	11.6µl	25µl
<b>Ni<sup>2+</sup> matrix</b>	100µl	100µl	100µl	100µl
<b>Buffer A2 + 10M Urea</b>	400µl	393.3µl	388µl	75µl
<b>Total</b>	1000µl	1000µl	1000µl	1000µl

After incubation of the solved inclusion bodies on the Ni<sup>2+</sup> matrix a number of samples were collected to analyze on SDS-PAGE. This was done in order to determine binding of the protein to the Ni<sup>2+</sup> matrix. The first sample consisted of the total amount of protein, that is present in the sample. The second sample was collected after the centrifugation step. The samples were centrifuged at 500rpm for 15 mins. A sample of the supernatant was taken and tested for protein that has not bound to the matrix. The pellet was washed with wash buffer and the centrifugation step was repeated. After the wash step a sample of the wash fraction was collected and this sample would indicate if any protein washes of the matrix. After washing the pellet was resuspended in the same volume of wash buffer and a sample of the matrix material was taken. This indicated the amount of protein bound to the Ni<sup>2+</sup> matrix.

3.2.6 Optimizing the volume of the Ni<sup>2+</sup> matrix required for optimal protein purification

The same procedures were followed as in 3.2.5. Different volumes of Ni<sup>2+</sup> matrix was used and 2 different concentrations of Imidazole (0mM and 20mM) can be included as stated in Table 3.2 and 3.3. As with the optimization of the Imidazole, here as well samples were analyzed on SDS-PAGE to determine which volumes of matrix would be ideal in binding the optimal amount of protein.

**Table 3.2** Optimising the volume of the Ni<sup>2+</sup> matrix using 0mM Imidazole.

	<b>0mM Imidazole</b>				
<b>Volume of Ni<sup>2+</sup> matrix</b>	100µl	75µl	50µl	25µl	12.5µl
<b>3M Imidazole</b>	0µl	0µl	0µl	0µl	0µl
<b>Buffer A2 /10M Urea</b>	100µl	125µl	150µl	175µl	187.5µl
<b>Solved inclusion bodies</b>	300µl	300µl	300µl	300µl	300µl
<b>Total Volume</b>	500µl	500µl	500µl	500µl	500µl

**Table 3.3** Optimising the volume of Ni<sup>2+</sup> matrix using 20mM Imidazole concentration.

	<b>20mM Imidazole</b>				
<b>Volume of Ni<sup>2+</sup> matrix</b>	100µl	75µl	50µl	25µl	12.5µl
<b>3M Imidazole</b>	3.33µl	3.33µl	3.33µl	3.33µl	3.33µl
<b>Buffer A2 /10M Urea</b>	96.7µl	121.7µl	146.7µl	171.7µl	184.7µl
<b>Solved inclusion bodies</b>	300µl	300µl	300µl	300µl	300µl
<b>Total Volume</b>	500µl	500µl	500µl	500µl	500µl

### 3.2.7 Purification and refolding of the protein on the Ni<sup>2+</sup> matrix

Once the proteins have been bound to the Ni<sup>2+</sup> matrix under denaturing conditions it has to be refolded. The inclusion bodies that were isolated were initially solubilized in urea and this resulted in the protein losing its active conformation (Tsumoto et. al; 2003). The protein therefore has to be refolded and recovered in its active form before it could be used in the immunisation protocol. Therefore the Ni<sup>2+</sup> matrix with bound protein was added to the filtration tubes with polyethylene frits. The wash buffer was removed by flow through after extensive washing of the columns with the bound protein. Subsequently the columns were washed with one volume of refolding buffer (50mM Tris HCl pH8, 2mM oxidized glutathione, 0.22mM reduced glutathione, 1M NDSB201) after which the columns were sealed at the opening at the bottom. The refolding process was then allowed to take place at 4°C overnight. After the overnight incubation the refolding buffer was discarded by removing the props and the columns and washing twice with 1xPBS. The openings were sealed again before adding the elution buffer (PBS + 50mM EDTA) and incubated for 10 mins at room temperature.

#### ***Alternative protocol to refolding:***

Two other refolding buffers were prepared to determine optimal refolding conditions for the two different proteins. Refolding buffer one (RFB1) consisted of 50mM Tris, 0.02mM oxidized glutathione, and 0.1mM reduced glutathione, 0.5M L-Arginine and 1M urea. Refolding buffer two (RFB2) was the same as RFB1 except that the urea was excluded and the pH of both the buffers was adjusted to pH6.5 using HCl. The purified his-tagged proteins were transferred to columns containing the polyethylene frits. The fraction was allowed to flow through before the first refolding buffer was added. The tubes containing the his-tagged proteins with RFB1 was incubated at 4°C for 3 hours and then the first refolding buffer was removed and RFB2 was added to the column. This was incubated at 4°C. After the overnight incubation the refolding buffer was discarded and the column material was washed twice with wash buffer (50mM Tris, 0.5M NDSB 201) [pH6.5]. Elutions were performed using elution buffer (80mM Tris, 100mM EDTA) [pH6.5]. EDTA is a chelating agent and therefore serves in stripping the metal ions from the Ni<sup>2+</sup> matrix and as a result the proteins are eluted. After the incubation period with the elution buffer, proteins are eluted from the column. Before the first elution samples of 20µl

were collected at various stages to be analyzed on SDS-PAGE. To determine if any protein was still bound to the Ni<sup>2+</sup> matrix samples were taken at different stages of the elution process. A quick test to determine if any protein was eluted from the column was to dot the samples on nitrocellulose paper (AEC, Amersham) and to stain the paper with Ponceau S (Sigma).

### 3.2.8 Dialysis and filtration of recombinant elephant and rhinoceros IFN $\gamma$

A molecular porous membrane of Molecular Weight Cut Off (MWCO) 6-8000kDa (Spectra/Por) was used to dialyze the recombinant elephant and rhinoceros interferon-gamma protein. The required length of membrane was cut and added to distilled water. This was then boiled at room temperature for 5 mins. One end of the membrane was knotted and PBS (phosphate buffered saline) was added to the membrane to check for leakages. The protein elutions collected in the previous steps was then added to the membrane. The other end of the tube was knotted and sealed with a clip. The protein filled membranes was placed into a liter beaker containing cold PBS buffer and incubated at 4°C for a few hours and the buffer was changed at regular intervals. To remove any precipitate that may have formed during the dialysis the protein solution was centrifuged at 14000rpm at 4°C for 15 mins. The protein was then filtered under sterile conditions in the flow cabinet using a 0.25 $\mu$ M filter. The filtered protein was aliquoted into 1ml cryo-tubes, labeled and stored at -20°C. Samples of the protein were collected at the following stages and analyzed on SDS-PAGE:

1. A sample before dialysis
2. A sample after dialysis
3. A sample of the supernatant after centrifugation
4. A sample of the precipitate, if any
5. A sample of the final filtered protein

The final protein concentration was determined using the Pierce BCA Protein Assay Kit.

### 3.2.9 SDS-PAGE Analysis

Protein extracts that were collected at various stages were analysed on SDS-PAGE (sodium dodecyl sulphate-polyacrylamide gel electrophoresis), according to

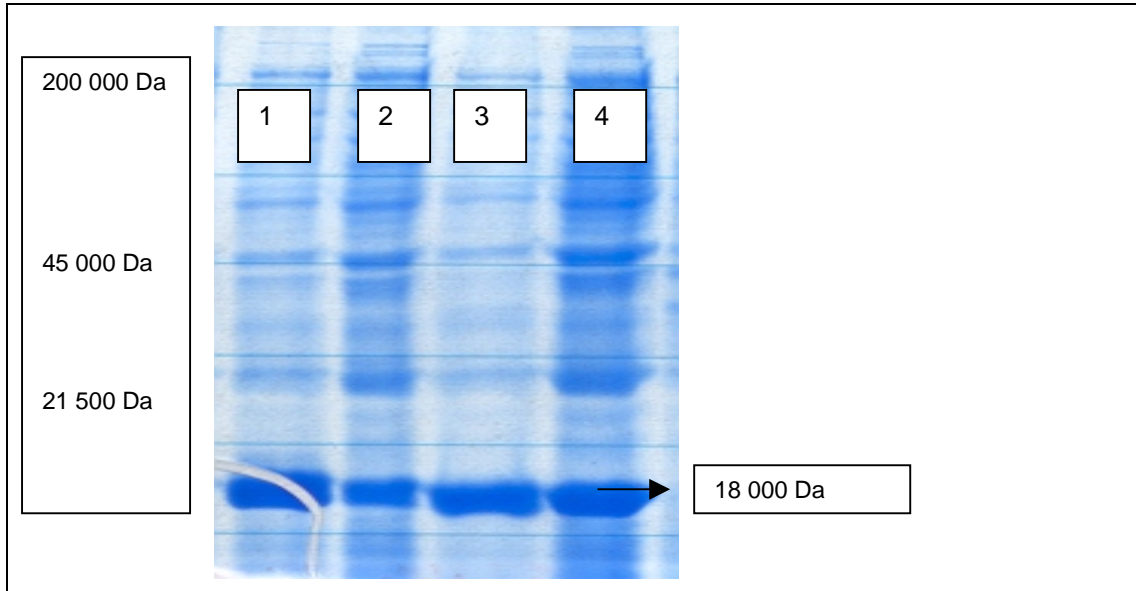
### University of Pretoria etd – Morar, D (2005)

Sambrook et al; (1989). Polyacrylamide gels (13%) consisted of a stacking gel (Tris HCl [pH6.8]) and resolving gel ( Tris HCl [pH 8.8]). All components of the system contained 1% SDS. To denature the proteins samples were prepared by heating them at 100°C for 3 to 10 mins in SDS-gel loading buffer. A standard protein solution (SDS-PAGE Broad range Molecular Marker–BioRad) was used as the molecular weight marker. Electrophoresis was performed using a power supply operated at a constant current of 16mA through the stacking gel and 30mA through the resolving gel.

Before staining the gels were washed three times with deionized water for 10 mins. The gels were then stained by immersing them in Gelcode® (Pierce) blue stain reagent for an hour using a rocker. To destain the gel, the staining solution was discarded and replaced with 2-3 times the volume of deionized water.

### 3.3 Results

Figure 3.2 below shows the results of the induction performed on a small scale for the recombinant elephant and rhinoceros IFN $\gamma$ .



**Figure 3.2** Analysis of the small-scale induction of the rhinoceros and elephant IFN $\gamma$  samples (total bacterial lysate of BL21DE codon+ cells) on SDS PAGE. Lane 1: rhinoceros IFN $\gamma$  pET15bGW before induction, Lane 2: rhinoceros IFN $\gamma$  pET15bGW after induction, Lane 3: elephant IFN $\gamma$  pET15bGW before induction, Lane 4: elephant IFN $\gamma$  pET15bGW after induction.

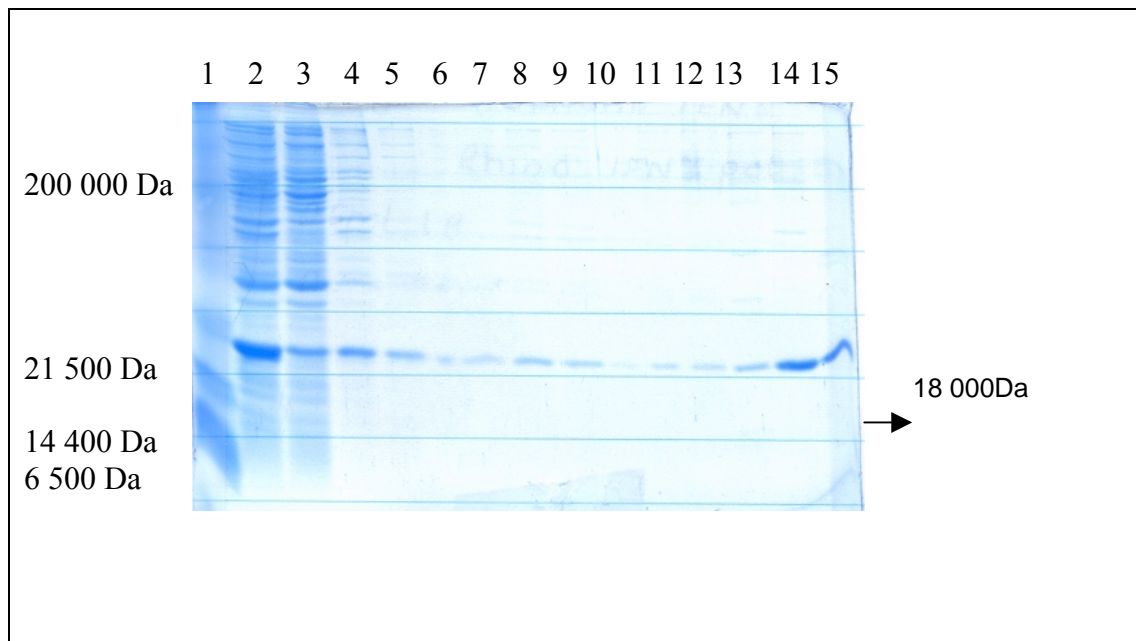
pET15bGW vectors containing the gene of interest (elephant IFN $\gamma$ , rhinoceros IFN $\gamma$ ) was successfully transformed into BL21DE codon+ cells for expression purposes. The size of protein that was obtained was 18 000 Da.

In order to determine the optimal Imidazole concentration and the ideal volume of Ni<sup>2+</sup> matrix required for optimum protein purification concentration, the following IFN $\gamma$  samples were used: chicken IFN $\gamma$ , cow IFN $\gamma$ , horse IFN $\gamma$ , human IFN $\gamma$  and mouse IFN $\gamma$ . The amount of protein that binds to the column decreases after an increase to 20mM. Results of the optimum amounts of Imidazole required for protein purification on the column for the rhinoceros IFN $\gamma$  and elephant IFN $\gamma$  will follow in Figures 3.3 and 3.4 respectively. From these results it may be read that the optimum



concentration of Imidazole required for purification on the  $\text{Ni}^{2+}$  matrix varies between 20mM and 30mM Imidazole. In the experiments that followed concentrations of 25mM and 20mM Imidazole were used. The volume of  $\text{Ni}^{2+}$  material required for optimum protein binding varied between 100 $\mu\text{l}$  and 50 $\mu\text{l}$  of column material per 300 $\mu\text{l}$  of solved protein.

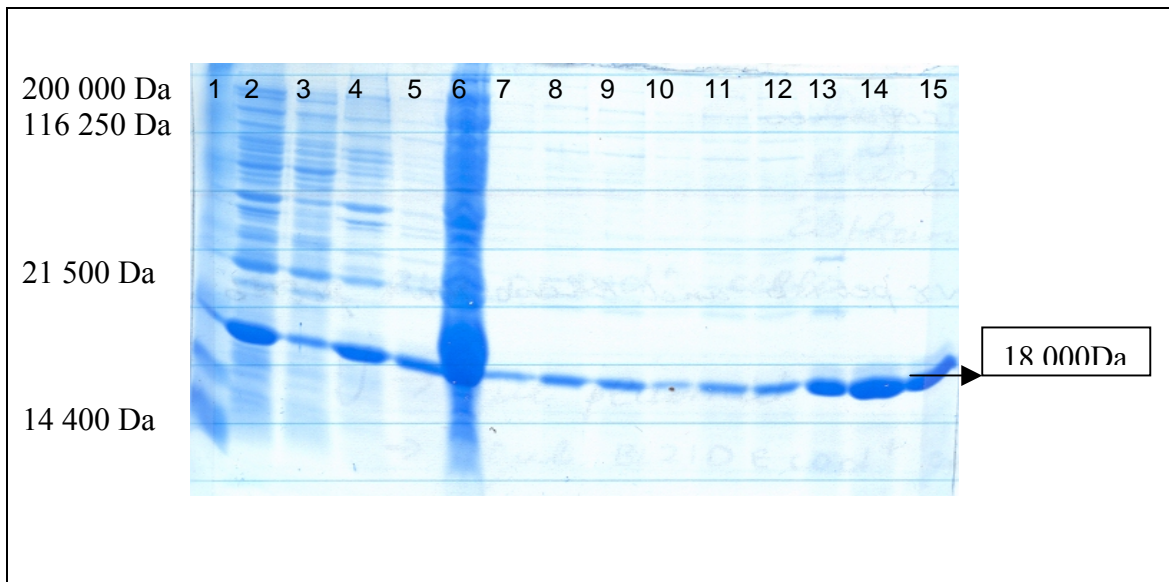
The following figure shows the results of the purification of recombinant rhinoceros IFN $\gamma$  on the  $\text{Ni}^{2+}$  matrix (100 $\mu\text{l}$  column material).



**Figure 3.3** SDS-PAGE showing the results from the stage of total protein lysate until purification on the  $\text{Ni}^{2+}$  matrix using different concentrations of Imidazole.

Lane 1: SDS-PAGE Broad range marker (Bio-Rad), Lane 2: Total protein lysate, Lane 3: Soluble fraction of total protein lysate after centrifugation, Lane 4: Fraction of total inclusion bodies, Lane 5: Solubilized inclusion bodies, Lane 6: Inclusion bodies that were not solubilized, Lanes 7, 8 and 9: Fraction of total protein bound to the column at 0mM, 20mM and 30mM Imidazole respectively before washing, Lanes 10, 11, and 12: Fraction of unbound proteins at 0mM, 20mM and 30mM Imidazole respectively, Lanes 13, 14 and 15: Fraction of the total protein bound to the matrix at 0mM, 20mM and 30mM Imidazole respectively, after washing but before eluting off the matrix.

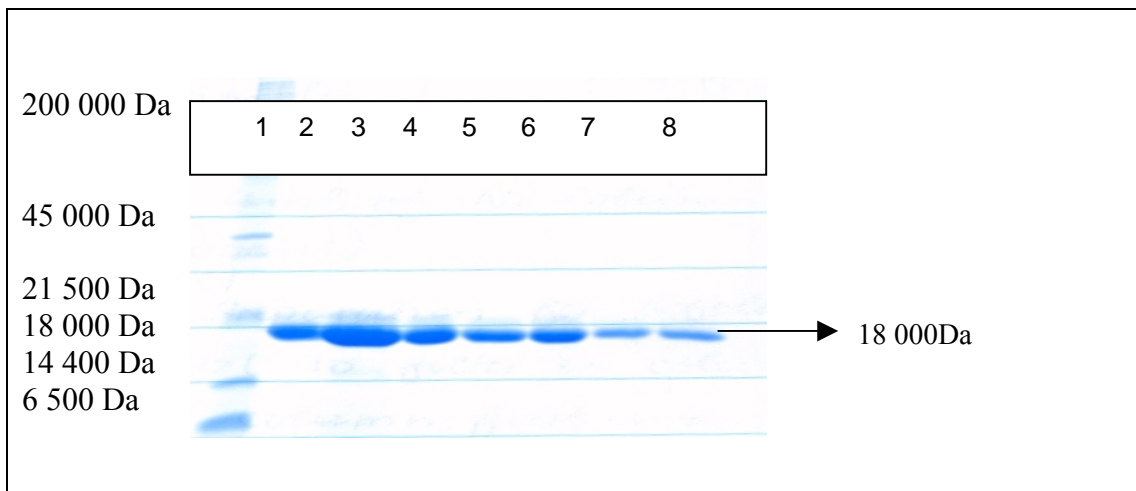
Figure 3.4 shows the purification results of recombinant elephant IFN $\gamma$  on the Ni $^{2+}$  matrix.



**Figure 3.4** SDS PAGE showing the results from the stage of total protein lysate until purification on the Ni $^{2+}$  matrix using different concentrations of Imidazole.

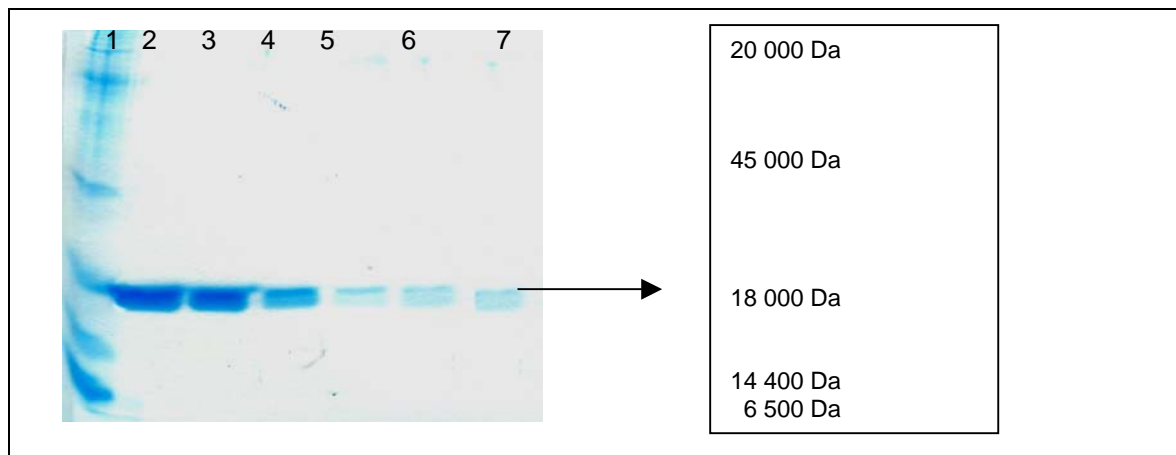
Lane 1: SDS-PAGE Broad range marker (Bio-Rad), Lane 2: Total protein lysate, Lane 3: Soluble fraction of total protein lysate after centrifugation, Lane 4: Fraction of total inclusion bodies, Lane 5: Solubilized inclusion bodies, Lane 6: Inclusion bodies that were not solved, Lanes 7, 8 and 9: Fraction of total protein bound to the column at 0mM, 20mM and 30mM Imidazole respectively before washing, Lanes 10, 11, and 12: Fraction of unbound proteins at 0mM, 20mM and 30mM Imidazole respectively, Lanes 13, 14 and 15: Fraction of the total protein bound to the matrix at 0mM, 20mM and 30mM Imidazole respectively, after washing but before eluting off the matrix.

The next two Figures (Figure 3.3 and 3.4) show the results obtained from the refolding experiment.



**Figure 3.5** SDS-PAGE analysis of protein (elephant IFN $\gamma$ ) after refolding on the Ni<sup>2+</sup> matrix.

Lane 1: Broad range marker (Bio-Rad), Lane 2: Sample representing the first elution (sample was dissolved in sample buffer without DTT), Lane 3: Sample before the first elution (protein bound to the matrix after refolding), Lane 4: Sample representing the first elution (sample dissolved in sample buffer with DTT), Lane 5: Sample representing the second elution, Lane 6: Sample representing the third elution, Lane 7: Sample representing the final elution, Lane 8: Ni<sup>2+</sup> matrix after the final elution (the amount of protein that does not elute of the matrix).



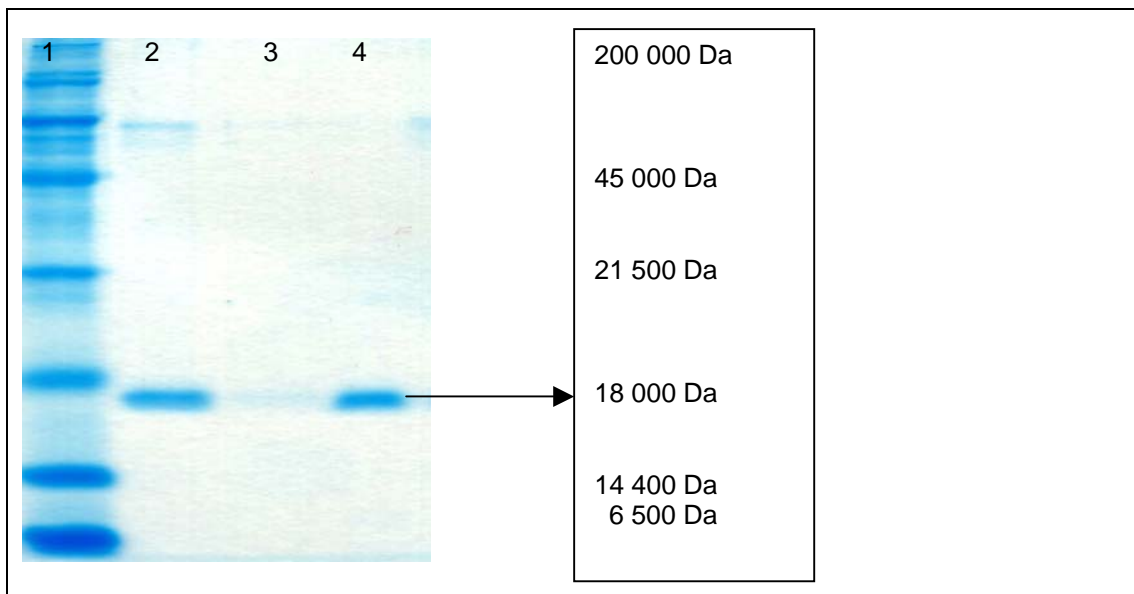
**Figure 3.6** SDS-PAGE analysis of protein (rhinoceros IFN $\gamma$ ) after refolding on the Ni $^{2+}$  matrix.

Lane 1: Broad range marker (Bio-Rad), Lane 2: Sample before the first elution (protein bound to the matrix after refolding), Lane 3: Sample representing the first elution, Lane 4: Sample representing the second elution, Lane 5: Sample representing the third elution, Lane 6: Sample representing the final elution, Lane 7: Ni $^{2+}$  matrix after the final elution (the amount of protein that does not elute of the matrix).

To recover the active IFN $\gamma$  protein from the inclusion bodies, which was obtained during protein isolation (Refer to 3.2.3), the protein had to be refolded.

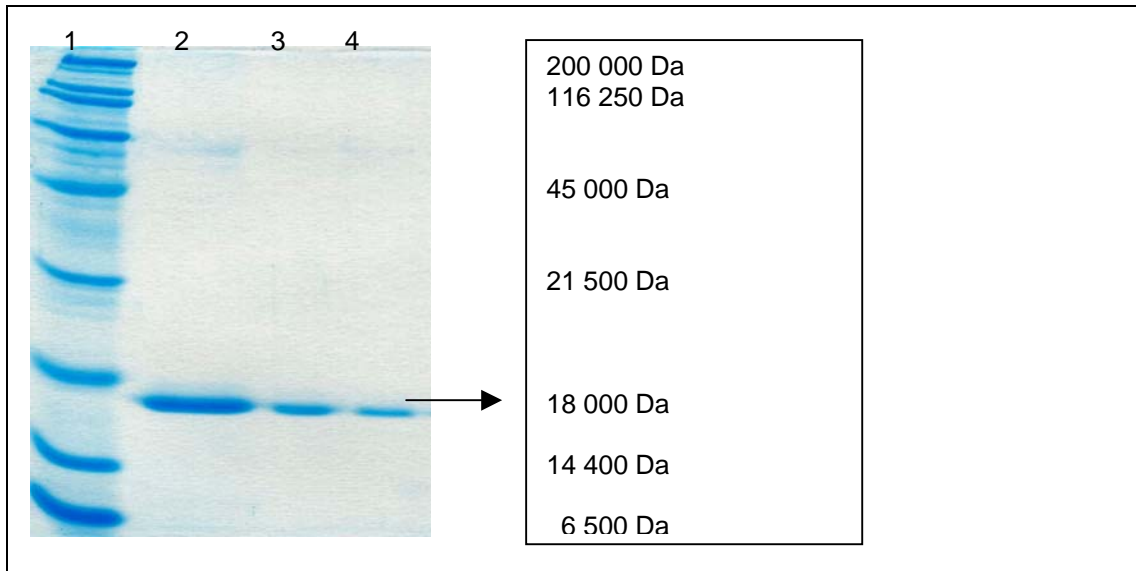
The results of the refolded products were analysed on SDS-PAGE. From Figures 3.5 and 3.6 it is noted that refolding of elephant IFN $\gamma$  and rhinoceros IFN $\gamma$ , respectively, was performed successfully.

The next two Figures (3.7 and 3.8) show the relative amounts of the final recombinant proteins after dialysis and filtration that were analysed on SDS-PAGE.



**Figure 3.7** Recombinant rhinoceros IFN $\gamma$  after dialysis and filtration

Lane 1: Broad range marker (Bio-Rad), Lane 2: recombinant protein after dialysis, Lane 3: protein precipitate formed after dialysis, Lane 4: Final recombinant purified rhinoceros IFN $\gamma$ .



**Figure 3.8** Recombinant elephant IFN $\gamma$  after dialysis and filtration

Lane 1: Broad range marker (Bio-Rad), Lane 2: Final purified recombinant elephant IFN $\gamma$  Lane 3: 2 times dilution of purified recombinant IFN $\gamma$ , Lane 4: 4 times dilution of IFN $\gamma$ .

The protein concentrations after dialysis of recombinant rhinoceros and elephant IFN $\gamma$  are tabulated in Table 3.4. As can be seen from the table the concentration of the protein was determined before and after storage at  $-20^{\circ}\text{C}$ . There are significant differences with regards to the protein concentrations before and after storage at  $-20^{\circ}\text{C}$ .

**Table 3.4** Protein concentration results

Recombinant Protein	Vector	Buffer used for dialysis	Protein concentration before storage at $-20^{\circ}\text{C}$	Protein concentration after storage at $-20^{\circ}\text{C}$
Rhino IFN $\gamma$	pET15bGW	PBS	180 $\mu\text{g/ml}$	11.26 $\mu\text{g/ml}$
Elephant IFN $\gamma$	pET15bGW	PBS	180 $\mu\text{g/ml}$	89.47 $\mu\text{g/ml}$
Rhino IFN $\gamma$	pET15bGW	Tris pH 7.5	47.58 $\mu\text{g/ml}$	
Elephant IFN $\gamma$	pET15bGW	Tris pH 7.5	39.58 $\mu\text{g/ml}$	

### 3.4 Discussion

#### 3.4.1 Transformation into BL21DE codon+ cells and the small scale induction of elephant IFN $\gamma$ and rhinoceros IFN $\gamma$ .

To determine expression of the recombinant proteins using the *E.coli* strain BL21DE codon+ harbouring pET15bGW with the IFN $\gamma$  genes of elephant and rhinoceros respectively. An induction on a small scale was performed. Results (Figure 3.2) show clear expression, however, protein expression was more prominent before inducing with IPTG than after induction. A possible reason for this is that lactose might have been present in the medium before the induction. LB medium is known to contain some lactose due to the use of amino acids derived from cow milk. When the inductions were performed on a larger scale glucose was included in the LB agar plates to suppress this “leaky” expression.

#### 3.4.2 Optimising the Ni $^{2+}$ matrix volume and the Imidazole concentration.

When determining the ideal volume of the Ni $^{2+}$  matrix required for protein purification, SDS-PAGE analysis of samples revealed the non-specific binding of other proteins to the matrix (results not shown). This was possibly due to the presence of outer-membrane proteins that, although not part of the inclusion body material, co-purified as non-solubilized protein with the inclusion body fraction. The most likely reason for contaminating proteins is the binding of other proteins to the Ni $^{2+}$  resin, because these proteins have some histidine patches. For this reason Imidazole was included in the buffers.

From the results obtained it could be concluded that the Imidazole concentration required for optimal protein purification varied with the samples (rhino IFN $\gamma$ , elephant IFN $\gamma$  compared to bovine IFN $\gamma$ ) that were used. From Figures 3.3 and 3.4 it is clear that samples showed a higher binding capacity at an Imidazole concentration of 20mM Imidazole. The elephant IFN $\gamma$  bound more efficiently to the matrix compared to the rhinoceros IFN $\gamma$  during purification on the Ni $^{2+}$  matrix, however, a considerable amount of protein was lost during the wash steps for the elephant sample. The temperature at which the binding of the protein to the matrix was

performed was adjusted from 4°C to room temperature in order to prevent precipitation of the urea in the wash buffer.

#### 3.4.3 Protein refolding on the Ni<sup>2+</sup> matrix

Since the proteins contain disulphide bonds the buffer used for the renaturation had to be supplemented with a redox system. To allow formation of reshuffling of disulphides a mixture of oxidised and reduced glutathione was added to the buffer. To determine if it would make a difference to the refolding process another refolding buffer was made which included L-arginine. In the literature it is stated that L-arginine highly stabilizes proteins and solubilizes folding intermediates, however, the mechanism of how L-arginine supports renaturation is not known (Lilie et.al; 1998). A concentration of less than 0.5M was not effective. With the initial use of refolding buffer with the inclusion of L-arginine it was found that the protein eluted during the removal of the refolding buffer before the elution step. This was as a result of the high alkalinity of the refolding buffer due to the presence of L-arginine, which has a pH 11. Changes were introduced to the refolding buffers. Firstly the concentration of the reduced and oxidised glutathione was changed from 0.02mM reduced glutathione to 0.1mM and 2mM oxidised glutathione to 0.02mM. Secondly NDSB201 (Non-detergent sulfobetaines) a non-denaturing protein solubilizing agent that prevents non-specific interactions was added. It also limits aggregation during refolding. The NDSB 201 was included initially but excluded from the refolding buffer and included in the wash buffer. The reason for its exclusion was that it made no difference to the efficiency of the refolding in this study. A very low concentration of urea (Merck) was included in the refolding buffer. The presence of urea would prevent the precipitation of the protein on the column. As mentioned in 3.2.7 two different refolding buffers were made of which the pH was adjusted from 11 to 6.5. The pH of the wash buffer and the elution buffer was also changed. With these changes it was noticed that when changing over from RFB1 (pH11) to RFB2 (pH6.5) no protein was eluted from the column, as experienced previously, before the pH was adjusted from 11 to 6.5. The protein did not flow out during the wash steps either. The protein yield was high for both samples, but in this protocol the yield of the rhinoceros IFN $\gamma$  compared to the elephant IFN $\gamma$ , using the initial refolding protocol (Refer to 3.2.7 – alternative protocol) was much higher. The isoelectric point (pI) of IFN $\gamma$  is



approximately 8. The initial conditions were not optimal and therefore not favourable to protein refolding possibly resulting in precipitation of most of the protein on the column. It, however, seems that the different proteins require different conditions when it comes to refolding and finally to optimizing the yield of protein. Therefore specific conditions for each protein have to be optimised accordingly. The buffers used differ with regards to the pH and the content of the reagents and have to be adjusted accordingly to achieve optimal protein elution of the matrix.

#### 3.4.4 Dialysis and filtration of recombinant elephant and rhinoceros IFN $\gamma$

PBS was the buffer selected against which the proteins were dialysed. However, PBS was not the ideal buffer as the protein precipitated during dialysis as well as during storage at  $-20^{\circ}\text{C}$ . A fraction of the protein that precipitated was analysed on SDS-PAGE to estimate the amount of protein that was lost. Almost 80% of the protein was lost. Tris/HCl buffer [pH7.5] was then used as dialysis buffer. It was noticed that precipitation of the protein during dialysis did not occur, however, a small amount did precipitate during centrifugation before filtering and only the supernatant was added to a clean tube without taking any of the precipitate. The reason the precipitate was removed was because it would interfere with the immunizations. To further prevent the precipitation of the protein during storage at  $-20^{\circ}\text{C}$ , 50% glycerol was added to the protein supernatant before filtering. The samples were labeled and stored at  $-20^{\circ}\text{C}$ . The final filtered purified samples were used for the mice immunizations.

## Chapter Four

### The production and selection of monoclonal antibodies

#### 4.1 Introduction

Interferon-gamma is involved in a variety of effector functions of the immune response (Pearl et.al; 2001). Apart from anti-viral activity IFN $\gamma$  has numerous other functions including the activation of macrophages thus increasing their ability to destroy ingested micro-organisms (Tizard; 1992, Male; 1991). The importance of IFN $\gamma$  in the protective response to tuberculosis (TB) has been demonstrated both experimentally and clinically and it has been shown that in its absence severe bacterial growth occurs which results in tissue destruction and death (Pearl et.al; 2001). Thus the absence of IFN $\gamma$  results in reduced macrophage activation and increases susceptibility to disease.

When animals become infected with *Mycobacterium bovis* they have lymphocytes in their blood that can recognise mycobacterial antigens. As a result of this recognition process production and secretion of the cytokine IFN $\gamma$  is induced.

Wood and co-workers (1990) produced and characterised monoclonal antibodies specific for bovine IFN $\gamma$  and included these monoclonals into an enzyme-linked immunoassay for bovine IFN $\gamma$ . This assay is known as BOVIGAM™ (patented by CSRIO Australia) and has been used successfully worldwide for the detection of TB in cattle (Wood et.al; 1990). BOVIGAM™ has been used for the diagnosis of TB in goats in Spain and has proven to be a useful technique. Its usefulness in detecting caprine tuberculosis was compared with a single intradermal test (SIDT). It was reported that the sensitivity of the IFN $\gamma$  assay was far greater than the SIDT and also enabled detection of the initial stages of the infection (Liebana et.al; 1998). In 1992 Billman-Jacobe and co-workers compared the IFN $\gamma$  assay with an absorbed ELISA technique for the diagnosis of Johne's disease in cattle. The IFN $\gamma$  assay was modified for detecting *M.paratuberculosis* infection. Results indicated that the IFN $\gamma$  assay showed good sensitivity and a high specificity in detecting animals at all stages of the disease, whereas the absorbed ELISA showed a sensitivity only in the late stages of

the infection but maintained a high specificity (Billman-Jacobe et.al; 1992). They also found that IFN $\gamma$  could be effective in the control of the incidence of disease in infected herds.

In this study the production of monoclonal antibodies to recombinant IFN $\gamma$  is one of the steps in the development of the IFN $\gamma$  diagnostic assay for TB detection in elephants and rhinoceros and in this chapter the generation of these monoclonals to recombinant elephant and rhinoceros IFN $\gamma$  is described.

## 4.2 Materials and Methods

Producing monoclonal antibodies (MoAbs) requires both *in vivo* and *in vitro* procedures. Mice were used to produce the desired antibodies.

### 4.2.1 Immunization protocol

The first step in producing monoclonal antibodies was to immunize the 12-week old Balb/C mice with the purified recombinant proteins. On day one the blood was collected before the mice were immunized with the antigens (Table 4.1). The mice were immunised with purified recombinant IFN $\gamma$  of 9 different animal species (Table 4.2). The expression and purification of the 7 other proteins was also done in conjunction with the elephant and rhinoceros IFN $\gamma$ . These recombinant proteins were generated with his-tag constructs. The only antigen used in the immunizations that did not consist of the his-tag region but a Nus-tag was the dog IFN $\gamma$ . The purpose of the combination immunizations was to produce monoclonal antibodies specific for interferon-gamma and to test for cross reactivity.

The mice were injected intraperitoneally with a total of 25 $\mu$ l of the recombinant proteins in specol, an oil based adjuvant, containing approximately a total of 15 $\mu$ g of each recombinant protein. The concentrations of all the recombinant proteins used were determined prior to the immunizations. The Pierce BCA protein assay kit was used to determine the concentrations of the various purified protein samples. After 21 days immunoserum was collected. Serum samples were used in ELISAs to determine

the serum antibody titres. When the desired titres were achieved the mice were euthanized, and their spleens removed. The immunization protocol used and the series of the immunizations are represented in Table 4.1 and Table 4.2 show the sequence of the antigens that was used for the respective immunizations.

**Table 4.1** Immunization Protocol for Balb/C mice:

<b>DAY 1</b>	<b>DAY 42</b>
Presera	Depending on the *specific serum titres the mice will get an additional booster, injection with an interval of 21 days, or the final booster immunisation. (250µl antigen in PBS i.p)
Collection of 100µl of blood before the start of the immunization.	
I.p. injection of a total of 250µl antigen (15µg) in specol. (Adjuvant antigen: specol = 4:5)	
<b>DAY 21</b>	<b>DAY 47/68/89</b>
	Depending on the total number of booster injections required to achieve a sufficiently high antibody titre.
Immunosera	Collect immunosera before the start of each booster immunization.
Collection of 100µl of blood before the 2 <sup>nd</sup> immunization.	
I.p. injection with 250µl antigen in specol. (Adjuvant antigen: specol = 4:5)	
<b>DAY 28/47/68/89</b>	
Immunosera	
Collect 100µl of blood immediately before new immunisation.	

The \*serum titres were evaluated during the immunization periods. Blood from the mice were collected before every immunization (Table 4.1) and the serum titres of the mice were determined using ELISA. When the desired titres were achieved the mice were euthanized using CO<sub>2</sub> and cervical dislocation.

**Table 4.2** Induction of cross-reacting antibodies

<b>Immunization</b>	<b>Antigens (IFN<math>\gamma</math>)</b>
<b>First</b>	Elephant, Horse and Rhinoceros
<b>Second</b>	Cow, Pig and Sheep
<b>Third</b>	Chicken, Dog and Rat
<b>Booster</b>	A combination of all the above-mentioned species.

#### 4.2.2 Isolation of spleen cells

Before the mice were euthanized a sample of 0.3ml of blood was collected from the tails. This blood served as a positive control in the ELISA reactions used to screen the hybridomas. The mice were euthanized and the spleen was removed and placed in 10ml of serum free medium A (serum free Opti-MEM contains HT + 1% PBS + 1% Glutamax (200mM)). A cell suspension was prepared in a petri-dish making use of the flat plunger surface of a plastic syringe. Clumps were removed while decanting the suspension into another tube. This suspension was then washed in 10ml serum free medium A and centrifuged at 150xg for 10 mins. The cells were now ready for fusion.

#### 4.2.3 Fusion technique

Spleen cells from the immunized mouse as described in 4.2.2 were fused with the mouse myeloma Sp2/0 cells using polyethylene glycol (PEG), which allows the cell membranes to fuse. Briefly, the mixed cell suspension, consisting of washed myeloma cells and a spleen cell suspension in a ratio of 1:5 (myeloma:spleen cells), was centrifuged at 150xg for 10 mins. The supernatant was discarded and the pellet was suspended in 1ml of a 94% PEG solution (2 grams polyethylene glycol 4000-MERCK, 2.1ml medium A). An equal volume of medium A (serum free Opti-MEM contains HT + 1% PBS + 1% Glutamax (200mM)) and PEG solution was added and

the cell suspension was allowed to stand for 90 secs. This was followed by the addition of 2ml of medium A and another addition of 5ml medium A after a 2 min period. After a further 2 mins, 5 ml of medium B was added to the cell suspension and it was centrifuged at 150xg for 10 mins. The supernatant was discarded and the cell pellet was resuspended with 10ml of medium B (medium A + 15% FCS). From this 100µl was used to count the myeloma cells. From the viable cells 200µl were pipetted into 96 well plates and incubated at 37°C in 7% CO<sub>2</sub>. After 5 days half of the medium was replaced and the cells were fed every 2 days by replacing 100µl of culture supernatant with 100µl fresh medium C (medium B + 1% aminopterin). Aminopterin was included to avoid the growth of original tumour cells.

After two weeks the aminopterin was left out of the medium and cells were refreshed with only medium B. The cells were at this stage ready for testing. Thereafter the supernatants from each well were tested for the presence of antibodies against the IFN $\gamma$  using an ELISA.

#### 4.2.4 Screening of hybridomas for antibody production

The following ELISA was used to screen hybridomas for antibodies to recombinant IFN $\gamma$ . ELISA plates (96-well Co-star) were coated with 50µl of purified recombinant interferon gamma (all the species that were used in the immunizations – Table 4.2) (1µg/ml) diluted in coating buffer (carbonate-bicarbonate, 0.1M, pH9.6) and incubated at 4°C overnight. The next day the coating buffer (pH9.6) was discarded and 100µl of blocking buffer was added to each well and incubated at 37°C for 30 mins. The block buffer (commercial buffer (Roche)) was removed and the plates were washed with wash buffer (tap water + 0.1% Tween 20). A volume of 50µl of the hybridoma culture supernatants, that was diluted in PBS containing 0.1% Tween 20 (PBS) and added to the plates at room temperature and incubated at 37°C for 1 hour. The plate was then washed five times with wash buffer. Anti-IFN $\gamma$  antibody was detected using 50µl per well of goat anti-mouse IgG (1:2000) horseradish peroxidase (HRP) conjugate (Boehringer Mannheim), diluted in blocking buffer and incubated for 1 hour at 37°C and washed as above. ABTS buffer (Boehringer Mannheim) was added, 50µl per well. After 10 mins the optical density was read at 405nm using an ELISA micro-plate reader (Bio-Rad). A second reading was taken a half-hour later.

To expand cells in culture the positive wells were transferred to 1ml cultures in 24 well tissue culture plates. The cultures were tested regularly using the IFN $\gamma$  ELISA and then expanded into 12 well tissue culture plates. Clones that remained positive in the IFN $\gamma$  ELISA were subcloned by “limiting dilution” method, which will ensure that the majority of the wells contain at most a single clone.

#### 4.2.5 Western Blot

The purified recombinant elephant IFN $\gamma$  (pET15bGW, with the his-tag region cleaved off) was loaded onto a SDS-PAGE gel. Two gels were prepared, since one would be used to test against clones that reacted positively to the his-tag. After running the protein on the gel, a blot was prepared to transfer the protein to a nitrocellulose filter paper. The apparatus for the transfer was set up and ran at a voltage of 74 for two gels and for a period of 1 hour.

Once the transfer to the filter paper was completed the blots were washed in ultra high quality water (UHQ). The commercial blocking reagent (Roche) used was prepared in PBSO. A volume of 50ml was used per blot. Included in the blocking buffer was 0.05% Tween. The blot was incubated at room temperature for 1 hour in blocking buffer. After discarding the blocking reagent the blots were individually incubated with the anti-his-tag antibody, produced by the 8E5 clone, and the anti-IFN $\gamma$ , (monoclonal antibody) produced by the 8E7 clone, respectively. Both the anti-IFN $\gamma$  and the anti-his-tag was diluted 1:100 in blocking buffer before incubation with the blots.

After an hour the blots were washed twice for 15 mins with PBSO + 0.05% Tween. The next step was to incubate the blots with a secondary antibody for 1 hour. The secondary antibody used was antimouse IgG Ap conjugate (1mg/ml) at a dilution of 1:3333. The incubation was followed by three wash steps with PBSO + 0.05% Tween. Detection was performed using alkaline phosphatase. Incubation was performed at room temperature for 2 hours, and finally washed with water for 10 mins.

#### 4.2.6 Mouse-hybridoma sub-typing/ELISA

In order to determine the immunoglobulin class, subclass and light chain type of the produced mouse monoclonal antibodies, a mouse-hybridoma sub-typing kit (Boehringer Mannheim) was used. The sub-typing was carried out according to the manufacturers instructions.

### 4.3 Results

Antibody titres in the mice against the different antigens that were developed during the course of the immunization in mice were determined by the Cytokine Centre (University Utrecht). Mice that had developed high anti-elephant and rhinoceros IFN $\gamma$  titres were used to generate specific hybridomas.

In the first ELISA (Table 4.3) all the recombinant IFN $\gamma$  samples were pooled and coated on to the ELISA plates. All the hybridoma supernatants (n=768) were screened. Most of these hybridomas showed background staining. The screening was repeated and from these results a selection of clones was made. The clones that finally turned out to be positive appeared to have been strongly positive from the start. Of these strongly positive clones only a few were found on each plate.

A selection of clones were made (n=480) and used in a screening with 4 different antigens separately. Individual plates were coated with dog IFN $\gamma$ , chicken IFN $\gamma$ , mouse IFN $\gamma$ , mouse GMCSF and another plate was coated with a combination of 6 different antigens which included elephant, horse, rhinoceros, sheep, cow and pig IFN $\gamma$ .

In the third screening, mouse GMCSF and a combination of IFN $\gamma$  antigens (as mentioned previously) were coated and a set of selected clones (n=141) were screened. The clones responded to both sets of antigens but weaker towards mouse GMCSF. By the fourth screening the number of clones to be screened were reduced, since only the strongly positive clones were selected. With this screening some clones were responding to specific antigens. In order to determine if antibodies produced by some (n=10) hybridomas were against IFN $\gamma$  of specific species the clones were tested



against all of the antigens individually. A number of clones reacted positively to his-tag (n=7) and three clones showed specificity for IFN  $\gamma$

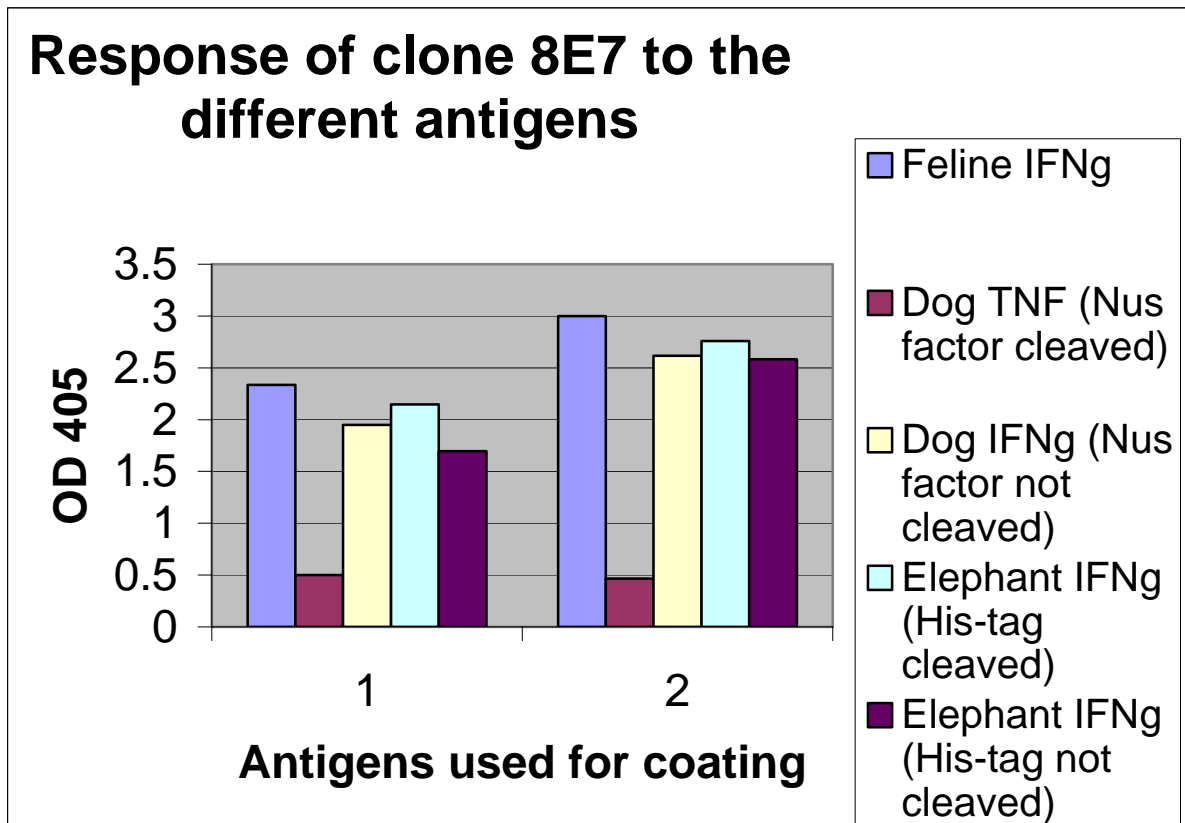
To verify the responses of the fifth screening a confirmation ELISA consisting of feline IFN $\gamma$  (commercial product), dog TNF $\alpha$  without the Nus-factor, dog IFN $\gamma$  with the Nus-factor, elephant IFN $\gamma$  without the his-tag and elephant IFN $\gamma$  with the his-tag, (As mentioned in the immunization procedure 4.2.1 the mice were immunised with recombinant IFN $\gamma$  proteins that consisted of his-tag constructs and the dog IFN $\gamma$  consisted of the Nus-tag construct). Clone 8E7 and clone 3E2 were used for the screening. The response was definitely against the protein coding region but as a further confirmation a Western blot was performed on elephant IFN $\gamma$  (Figure 4.2). This step was not performed on the rhinoceros IFN $\gamma$  sample. During the cleavage of the thrombin and his-tag regions from recombinant rhinoceros IFN $\gamma$ , a large quantity of the protein was lost during the procedure. The amount of protein that remained and concentration was not sufficient for the Western blot. The results of the screening of the hybridoma supernatants are summarized in Table 4.3.

**Table 4.3** Screening of hybridomas

Number of ELISAs	Antigens coated	Outcome
1	Nine IFN $\gamma$ antigens were pooled and used to coat the ELISA plate.	A number of clones were selected and thereafter used in the second screening
2	Dog IFN $\gamma$ Chicken IFN $\gamma$ Mouse IFN $\gamma$ Mouse GMCSF <u>Combination:</u> <ul style="list-style-type: none"> <li>• Elephant IFN<math>\gamma</math>,</li> <li>• Cow IFN<math>\gamma</math>,</li> <li>• Horse IFN<math>\gamma</math>,</li> <li>• Pig IFN<math>\gamma</math>,</li> <li>• Rhino IFN<math>\gamma</math> &amp;</li> <li>• Sheep IFN<math>\gamma</math>.</li> </ul>	The clones that were selected from the first screening, where they were initially screened against pooled samples of IFN $\gamma$ , were now used to screen against 4 individually coated antigens as well as to a selected combination of IFN $\gamma$ samples. This was done to determine if the antibodies produced were specific or cross-reactive. A number (n=80) of clones were found to be reactive to the combination sample and there was also a number (n=61) of clones that responded to the dog IFN $\gamma$ and the chicken IFN $\gamma$ antigens.
3	<ul style="list-style-type: none"> <li>• Mouse GMCSF</li> <li>• Combination IFN<math>\gamma</math></li> </ul>	Once again these clones (n=141) were *selected and cultured further to be screened against a pooled sample of IFN $\gamma$ and a control mouse GMCSF. The results indicated that some clones were reactive towards IFN $\square$ and some to the his-tag of mouse GMCSF.
4	<ul style="list-style-type: none"> <li>• Chicken IFN<math>\gamma</math></li> <li>• Dog IFN<math>\gamma</math></li> <li>• Combination IFN<math>\gamma</math></li> <li>• Mouse GMCSF</li> </ul>	With this set of screenings it was found that some clones reacted positively with chicken IFN $\gamma$ , a number of the clones reacted with the pooled sample and another set that reacted with the dog IFN $\gamma$ .
5.	<ul style="list-style-type: none"> <li>• Chicken IFN<math>\gamma</math></li> <li>• Cow IFN<math>\gamma</math></li> <li>• Dog IFN<math>\gamma</math></li> <li>• Elephant IFN<math>\gamma</math></li> <li>• Horse IFN<math>\gamma</math></li> <li>• Pig IFN<math>\gamma</math></li> <li>• Rat IFN<math>\gamma</math></li> </ul>	The 5th screening of the clones were tested against all of the antigens, individually. The results showed a number (n=4) of clones that reacted positively to his-tag, one clone, 7D2, was specific for chicken IFN $\gamma$ , a second clone,

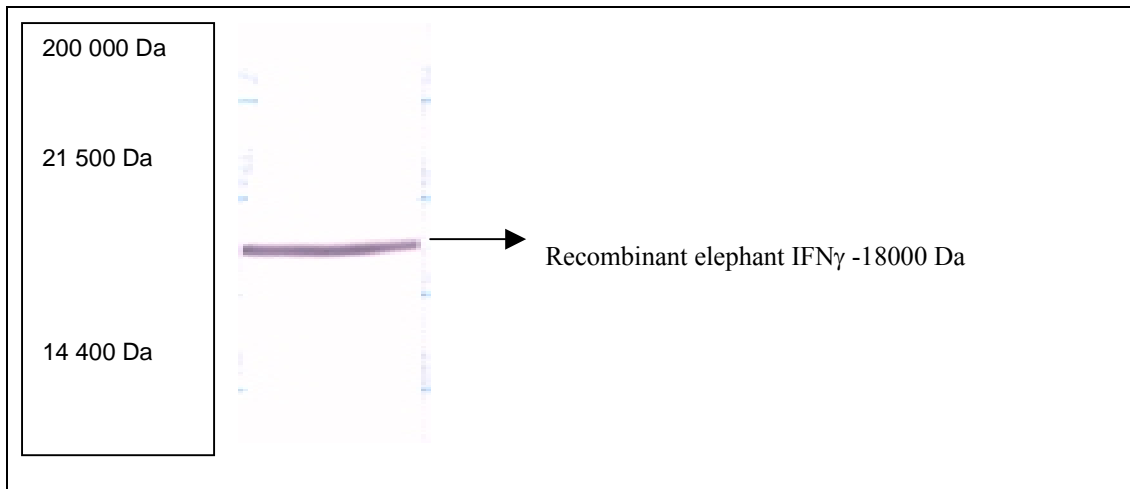
	<ul style="list-style-type: none"> <li>• Rhino IFN<math>\gamma</math></li> <li>• Sheep IFN<math>\gamma</math></li> <li>• Mouse IFN<math>\gamma</math></li> <li>• Mouse GMCSF</li> </ul>	<p>3E2 was reactive to dog IFN<math>\gamma</math>. A third clone was reactive to dog IFN<math>\gamma</math>, elephant IFN<math>\gamma</math>, horse IFN<math>\gamma</math>, cow IFN<math>\gamma</math>, rhinoceros IFN<math>\gamma</math> and to a lesser extent to sheep IFN<math>\gamma</math>.</p>
6	<ul style="list-style-type: none"> <li>• Commercial Feline IFN<math>\gamma</math></li> <li>• Dog TNF</li> <li>• Dog IFN<math>\gamma</math></li> <li>• Elephant IFN<math>\gamma</math> (his-tag cleaved off)</li> <li>• Elephant IFN<math>\gamma</math> (his-tag not cleaved)</li> </ul>	<p>To confirm the results obtained in the previous screening, as well as to confirm if the responses obtained were indeed towards the active protein and not to the his-tag and Nus factor regions this ELISA was performed. This ELISA consisted of two samples that were not used to immunize the mice i.e. Dog TNF<math>\alpha</math> and Feline IFN<math>\gamma</math>.</p> <p>Clone 8E7 was tested on all antigens and clone 3E2 was only tested against the dog and feline IFN<math>\gamma</math> samples as it was clear from the previous ELISA's that it was not reactive with IFN<math>\gamma</math> of the other species. Results of this ELISA confirmed that the response was indeed towards the protein coding region and not to the his-tag or Nus-factor.</p> <p>A positive response to the Feline IFN<math>\gamma</math> also indicated that this clone 8E7 was cross-reacting with the species which was not used in the immunization.</p> <p>Clone 8E7, however, did not react to the dog TNF<math>\alpha</math> sample also a positive sign, indicating its specificity to IFN<math>\gamma</math> in stead of specificity for Nus/his-tag.</p> <p>Results are shown graphically in figure 4.1.</p>

\* Selection of clones was determined by the values obtained after reading the plates at a wavelength of OD<sub>405</sub>. The readings for each antigen differed and the criteria of selection for the clones differed for all antigens.



**Figure 4.1** Results of the responses of Clone 8E7 to feline IFN $\gamma$ , dog TNF $\alpha$ , dog IFN $\gamma$ , elephant IFN $\gamma$  without the his-tag region and elephant IFN $\gamma$  with the his-tag. One represents the first reading and 2 represents the second set of readings that were taken.

From Table 4.3 and Figure 4.1 it is clear that the difference between the responses of the elephant sample that had the his-tag region cleaved off and the one which the his-tag region was not cleaved was not high.



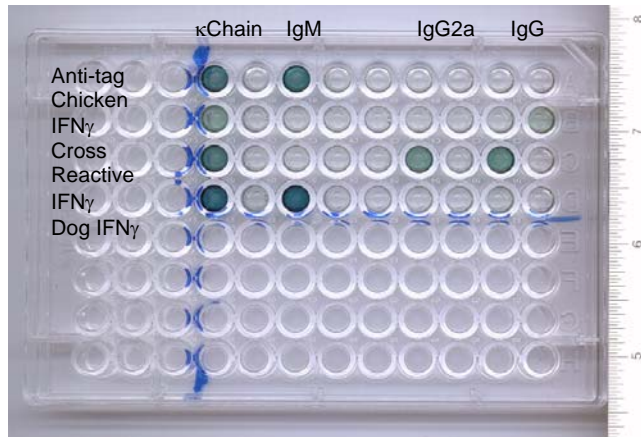
**Figure 4.2:** Western blot of recombinant elephant IFN $\gamma$  (construct without the his-tag region). Clone 8E7 (the clone that shows cross reactivity) and four different clones that showed positive for the his-tag was used in the blot as described in 4.2.5.

There was no reaction to the his-tag, which was used as the control (results not shown). This confirmed that the antibodies produced by the 8E7 clone are specific for the elephant IFN $\gamma$ , and from the results obtained in the ELISA (Table 4.2, number 6) it is clear that it is cross reactive for rhinoceros IFN $\gamma$ , feline IFN $\gamma$ , dog IFN $\gamma$ , horse IFN $\gamma$  and cow IFN $\gamma$ .

The different immunoglobulin classes, subclasses and the light chain type of the mouse monoclonal antibodies were determined are shown in Table 4.2 and Figure 4.3.

**Table 4.2** Results of the subtyping

Clone	Ig Class	Light chain
7D2-chicken IFN $\gamma$	IgA	$\kappa$ -kappa light chain
8E7-cross reactive IFN $\gamma$	IgG, IgG2a	$\kappa$ -kappa light chain
3E2-dog IFN $\gamma$	IgM	$\kappa$ -kappa light chain
8E5-anti-his	IgM	$\kappa$ -kappa light chain



**Figure 4.3** Subtyping of the different clones obtained during the screening of the hybridoma clones.

#### 4.4 Discussion

This chapter describes the generation of antibodies to various IFN $\gamma$  species. Twelve week old Balb/C mice were immunized with recombinant IFN $\gamma$  of different species. A single fusion was performed and wells which showed positive growth of hybridomas were then screened for antibodies to IFN $\gamma$  by the use of an IFN $\gamma$ -specific ELISA.

The initial ELISAs that were performed were used to select the clones which reacted most positively, from the 768 hybridomas tested initially 480 were selected and the remainder reacted to a lesser extent. The hybridoma supernatants were screened and with each screening the number of probable clones were reduced due to the fact that they were false positives. As noted in Table 4.3 a variation of the antigens were also used for screening. Only a small number of clones showed specificity and only one clone showed cross reactivity. In all the ELISAs mouse GMCSF was also included. Initially the mice were to be immunized with the proteins which had the his-tag region cleaved off but during the initial small scale his-tag cleaving experiments it was deduced that this would not be feasible because the protein concentration was reduced. Therefore the mice were immunized with the his-tag not cleaved from the purified recombinant IFN $\gamma$  proteins as described in 4.2.1. Recombinant mouse GMCSF also had been generated with an identical his-tag as present in the recombinant IFN  $\gamma$  that had been used for immunization. This GMCSF served as a control to determine if a response was specific of the IFN $\gamma$  moiety or for the

purification tag. In all cases there was a background response to mouse GMSCF but much lower than the responses obtained against the IFN $\gamma$  samples. During the expression experiments of dog IFN $\gamma$  it was found that expression of dog IFN $\gamma$  using the pET15bGW vector was not successful. It was therefore cloned into the pET43bGW vector which consists of the Nus-factor instead of the his-tag region (Refer to chapter 2). This Nus region contributes to increasing the solubility of the protein.

To confirm that the antibodies were directed to the IFN $\gamma$  and not to the his<sub>6</sub>- or Nus-tag that were present in the recombinant proteins, the antibodies were also tested against the recombinant IFN $\gamma$ s with the tags cleaved off. The response to the elephant IFN $\gamma$  construct without the his-tag was comparable to that with the his-tag (Figure 4.1) still present, demonstrating that the antibody was not directed to the tag, but to IFN $\gamma$ . The mice were not immunized with feline IFN $\gamma$  but the response to feline IFN $\gamma$  was comparable to the response to dog and elephant IFN $\gamma$  demonstrating that cross-reactivity can even be generated against IFN $\gamma$  of species that were not included in the immunizations. In addition the low background response to dog TNF $\alpha$  without the Nus factor confirmed that the response was specific to IFN $\gamma$  and not to the Nus-tag. The difference between the elephant IFN $\gamma$  with the his-tag cleaved off and the elephant IFN $\gamma$  with the his-tag and dog IFN $\gamma$  with the Nus-factor was not significant in ELISA.

To exclude the possibility that the antibody was reactive against a minor bacterial protein co-purified with the recombinant IFN $\gamma$ s a Western blot (Figure 4.2) was performed. In this Western blot clone 8E7 stained only a band of the size expected for the recombinant elephant IFN $\gamma$ . In addition the low antibody response to dog TNF $\alpha$  without the Nus-factor confirmed that the response was specific to IFN $\gamma$ . Since the difference between the elephant IFN $\gamma$  with the his-tag cleaved off and the elephant IFN $\gamma$  with the his-tag and the dog IFN $\gamma$  with the Nus-factor was not significant. A Western blot (Figure 4.2) indicated that the cross-reactive antibodies produced by the clone 8E7 was indeed against the IFN $\gamma$  region and not the his-tag.

### University of Pretoria etd – Morar, D (2005)

The results of this research will lead to the first diagnostic test for the detection of tuberculosis in elephants and rhinoceros using IFN $\gamma$ 's. The same procedures will be followed in future studies on other wildlife species. Further studies on the development of an IFN $\gamma$  for the detection of TB in pachyderms will entail testing trials for the basis of a capture ELISA, much like the sensitive capture ELISA developed by McWaters and co-workers (2000), using the ovine Interleukin 6 (IL6) cytokine. They combined a monoclonal antibody with polyclonal sera and with this ELISA demonstrated that ovine IL6 could be detected in efferent lymph draining from a stimulated popliteal lymph node.

In addition the assay will be evaluated in conjunction with other parameters including culturing techniques, ELISA and history regarding infection status to evaluate its usefulness in the detection of elephant and rhinoceros IFN $\gamma$ . At present the intradermal tests that were performed in elephants have not correlated positively with cultured samples (Mikota et.al 2001) and the tuberculin test in rhinoceros has yet to be validated. In elephants and rhinoceros serology assays and other indirect methodologies such as cellular responsiveness to mycobacterial antigens lack validation. Radiographic thoracic evaluation is only feasible in young elephants. In 1997 an elephant TB screening protocol was established and guidelines for the control of tuberculosis in elephants was compiled by the National Tuberculosis Working Group For Zoo and Wildlife Species (USA) (Mikota et.al; 2000, Mikota et.al; 2001).

Preliminary results obtained in this study indicates that this assay will be useful as a screening test.



## **Chapter Five**

### **Concluding Remarks**

The spread of tuberculosis in African game parks is on the rise and it is a serious problem. Bovine tuberculosis not only threatens the biodiversity in these parks but can also have an impact on livestock farming (Michel, 2002). In addition it puts a standstill on translocation exercises (Buddle et.al; 2001).

In wild animals apart from bovines only the skin test together with culturing techniques and ELISA's are available for the diagnosis of the disease. Skin tests have shown to be both impractical and unreliable for use in pachyderms. The ELISA on the other hand cannot be used for the early detection of the disease.

This study, reports the steps that were taken to developing an IFN $\gamma$  assay for the diagnosis of tuberculosis in elephants (*Loxodonta africana*) and rhinoceros (*Diceros bicornis*). The gene of interest, IFN $\gamma$ , of both these species was cloned, sequenced, purified and a monoclonal antibody was produced. The mature protein region of the gene has been sequenced and the gene of interest was successfully cloned into the desired vectors for protein expression using the GW cloning technique. The purified recombinant proteins were expressed and produced in the desired quantities. This was then followed by the successful immunizations of mice for the production of monoclonal antibodies against IFN $\gamma$  of various species. Three monoclonals were obtained and one was cross-reactive to 7 IFN $\gamma$  species.

#### **Continuing and future research**

The monoclonal antibody and others that were produced in this study will be used in setting up a capture ELISA. This ELISA would be the first step in the final development of the assay for TB detection in elephants and rhinoceros based on the cytokine IFN $\gamma$ . In setting up this ELISA a number of factors and parameters have to be determined and optimised, e.g. sensitivity and specificity. Preliminary tests will be performed as well as validation of the assay using field samples. For the latter the selection and the specificity of the antigen and controls used for the stimulation of

## University of Pretoria etd – Morar, D (2005)

IFN $\gamma$  production are going to be the major challenges to deal with. It has become clear that especially in elephants apart from *M.bovis* (to be proven) also *M.tuberculosis* (Mikota et.al; 2000) infection is of relevance.

### Advantages and final outcomes

This IFN $\gamma$  diagnostic assay can be performed within 24-48 hours and will be an advantage since it will be rapid enough for a wild animal to be caught and held until the results of the tests are known. *In vitro* cell mediated tests for these animals have the advantage of requiring only one handling of the animal as well as detecting cell mediated responses that are likely to predominate in subclinical cases of TB.

The application of this assay will be of great economic significance since it will provide the first diagnostic test suitable to the diagnosis of TB in pachyderms and depending on the success of this assay, plans of developing a similar assay for detecting TB in lions will also be underway. The remaining research of this project is still continuing and will form part of a PhD programme.

## References

**Alexander KA, Pleydell E, Williams MC, Lane EP, Nyange JFC and Michel AL.** 2002. Mycobacterium tuberculosis: An emerging disease of free-ranging wildlife. *Emerging Infectious Diseases*, 8 (6): 598-601.

**Amadori M, Lyashchenko KP, Gennaro ML, Pollock JM and Zerbini I.** 2002. Use of recombinant proteins in antibody tests for bovine tuberculosis. *Veterinary Microbiology*, 85: 379-389.

**Anisa JA, Martin C and Gicquel B.** 2001. Micro Meeting: Molecular approaches to tuberculosis. *Molecular Microbiology*, 42 (2): 561-570.

**Ashford DA, Whitney E, Raghunathan P and Cosivi O.** 2001. Epidemiology of selected mycobacteria that infect humans and other animals. *Rev. Sci. tech. Off. int. Epi.*, 20 (1): 325-337.

**Bengis RG, Kriek NPJ, Keet DF, Raath JP, De Vos V, and Huchzermeyer HFAK.** 1996. An outbreak of bovine tuberculosis in free-living African buffalo (*Syncerus caffer* – Sparrman) population in the Kruger National Park: a preliminary report. *Onderstepoort Journal of Veterinary Research*, 63: 15-18.

**Billman-Jacobe H, Carrigan M, Cockram F, Corner LA, Gill IJ, Hill JF, Jessep T, Milner AR and Wood PR.** 1992. A comparison of the interferon-gamma assay with the absorbed ELISA for the diagnosis of Johne's disease in cattle. *Australian Veterinary Journal*, 69 (2):25-28.

**Buddle BM, Nolan A, McCarthy AR, Heslop J, Aldwell FE, Jackson R., and Pfeiffer DU.** 1995. Evaluation of 3 serological assays for the diagnosis of *Mycobacterium bovis* infection in brushtail possums. *New Zealand Veterinary Journal*, 43: 91-95.

**Buddle BM, Skinner MA and Chambers MA.** 2000. Mini Review: Immunological approaches to the control of tuberculosis in wildlife reservoirs. *Veterinary Immunology and Immunopathology*, 74:1-16.

**Cavirani S, Fanti F, Conti S, Calderaro A, Foni E, Dettori G, Chezzi C and Scatozza F.** 1999. Detection of *Mycobacterium bovis* in bovine tissue samples by the Abbott LCX *Mycobacterium tuberculosis* assay and comparison with culture methods. *New Microbiology*, 22:343-349.

**Coker C, Majid M and Radulovic S.** 2003. Development of *Rickettsia prowazekii* DNA vaccine: cloning strategies. *Ann. N Y Acad. Sci.*, 990:757-764.

**Collins DM, Radford AJ, De Lisle GW and Billman-Jacobe H.** 1994. Diagnosis and epidemiology of bovine tuberculosis using molecular biological approaches. *Veterinary Microbiology*, 40:83-94.

**Daborn C.** 1995. Tb in humans and domestic animals in the developing world. In *Tuberculosis in Wildlife and domestic animals*, eds F. Griffin and G. De Lisle. Dunedin: University of Otago Press.

**De Lisle GW, Bengis RG, Schmitt SM and O'Brein DJ.** 2002. Tuberculosis in free-ranging wildlife: Detection, diagnosis and management. *Rev. Sci. tech. Off. int. Epiz.*, 21 (2):317-334.

**DeVos V, Bengis RG, Kriek NP, Michel AL, Keet DF, Raath JP and Huchzermeyer HF.** 2001. The epidemiology of tuberculosis in free-ranging African buffalo (*Syncerus caffer*) in the Kruger National Park, South Africa. *Onderstepoort Journal of Veterinary Research*, 68 (2):119-30.

**Grange JM and Yates MD.** 1994. Zoonotic aspects of *Mycobacterium bovis* infection. *Veterinary Microbiology*, 40:137-151.

**Griffin JFT and Buchan GS.** 1994. Aetiology, pathogenesis and diagnosis of *Mycobacterium bovis* in deer. *Veterinary Microbiology*, 40: 193-205.

**Grobler DG, Michel AL, DeKlerk LM and Bengis RG.** 2002. The gamma-interferon test: its usefulness in a bovine tuberculosis survey in African buffaloes (*Syncerus caffer*) in the Kruger National Park. Onderstepoort Journal of Veterinary Research, 69:221-227.

**Ibelgaufts H.** 1999. Cytokines online pathfinder encyclopaedia. [www.copewithcytokines](http://www.copewithcytokines)

**Janeway CA and Travers P.** 1997. Immunology –The Immune System in Health and Disease. 3<sup>rd</sup> edition.

**Katial RK, Hershey J, Purohit-Seth T, Belisle JT, Brennan PJ, Spencer JS and Engler RJM.** 2001. Cell-Mediated immune responses to tuberculosis antigens: Comparison of skin testing and measurement of in-vitro gamma interferon production in whole blood culture. Clinical and Diagnostic Laboratory Immunology, 8 (2):339-345.

**Keet DF, Kriek NPJ, Penrith ML, Michel AL and Huchzermeyer.** 1996. Tuberculosis in buffaloes (*Syncerus caffer*) in the Kruger National Park: Spread of the disease to other species. Onderstepoort Journal of Veterinary Research, 63:239-244.

**Lepper AWD, Pearson CW and Outteridge PM.** 1973. Assessment of bentonite flocculation test for detecting tuberculosis in cattle. Australian Veterinary Journal, 49:445-450.

**Lepper AWD and Pearson CW.** 1975. The indirect fluorescence antibody test for the detection of circulating antibodies in bovine tuberculosis. Australian Veterinary Journal, 51:256-261.

**Levy A, Fraenkel-Conrat and Owens RA.** 1994. Virology 3<sup>rd</sup> edition. Prentice Hall, Upper Saddle River, New Jersey.

**Liebana E, Aranaz A, Uргуia JJ, Mateos A and Dominguez L.** 1998. Evaluation of the gamma-interferon assay for eradication of tuberculosis in a goat herd. Australian Veterinary Journal, 76 (1):50-53.

**Lilie H, Schwarz E, and Rudolp R.** 1998. Advances in refolding of proteins produced in E.coli. Current Opinion in Biotechnology, 9:497-501.

**Male D.** 1991. Immunology – An Illustrated Outline, 2<sup>nd</sup> edition, Gower Medical Publishing.

**Mann PC, Bush M, Janssen DL, Frank ES and Montali RJ.** 1981. Clinicopathologic correlations of tuberculosis in large zoo mammals. Journals of the American Veterinary Medical Association, 179 (11):1123-1129.

**McWaters P, Hurst L, Chaplin RJ, Collins RA, Wood PR and Scheerlinck J-PY.** 2000. Characterization of monoclonal antibodies to ovine interleukin 6 and the development of a sensitive capture ELISA. Veterinary Immunology and Immunopathology 73:155-165.

**Michalak K, Austin C, Diesel S, Bacon JM, Zimmerman P and Maslow JN.** 1998. mycobacterium tuberculosis infection as a zoonotic disease: transmission between humans and elephants. Emerging infectious Diseases, 4:282-287.

**Michel AL.** 2002. Implications of tuberculosis in African wildlife and livestock. Ann. N.Y. Acad. Sci. 969:251-255.

**Mikota SK, Larsen RS and Montali RJ.** 2000. Tuberculosis in elephants n North America. Zoo Biology, 19:393-403.

**Mikota SK, Peddie L, Peddie J, Isaza R, Dunker F, West G, Lindsay W, Larsen S, Salman MD, Chatterjee D, Payeur J, Whipple D, Thoen C, Davis DS, Sedgwick C, Montali RJ, Ziccardi M and Maslow J.** 2001. Epidemiology and diagnosis of *Mycobacterium tuberculosis* in captive asian elephants (*Elephas maximus*). Journal of Zoo and Wildlife Medicine 32 (1):1-16.

**Monaghan ML, Doherty ML, Collins JD, Kazda JF and Quinn PJ.** 1994. The tuberculin test. *Veterinary Microbiology*, 40:111-124.

**Montali RJ, Mikota SK and Cheng LI.** 2001. *Mycobacterium tuberculosis* in zoo and wildlife species. *Rev. Sci. Tech.* 20 (1):291-303.

**Morris RS, Pfeiffer DU and Jackson R.** 1994. The epidemiology of *Mycobacterium bovis* infections. *Veterinary Microbiology*, 40:153-177.

**Neill SD, Cassidy J, Hanna J, Mackie P, Pollock JM, Clements A, Walton E and Bryson DG.** 1994. Detection of *Mycobacterium bovis* infection in skin-test negative cattle with an assay for bovine interferon-gamma. *The Veterinary Record*.

**Neill SD, Pollock JM, Bryson DB and Hanna J.** 1994. Pathogenesis of *Mycobacterium bovis* infection in cattle. *Veterinary Microbiology* 40:41-52.

**Nolan A and Wilesmith JW.** 1994. Tuberculosis in badgers (*Meles meles*). *Veterinary Microbiology*, 40:179-191.

**Parr RD and Ball JM.** 2003. New donor vector for generation of histidine-tagged fusion proteins using the Gateway Cloning System. *Plasmid*, 49 (2):179-183.

**Pearl JE, Saunders B, Ehlers S, Orme IM and Cooper AM.** 2001. Inflammation and lymphocyte activation during mycobacterial infection in the interferon-gamma deficient mouse. *Cellular Immunology*, 211:43-50.

**Pollock JM and Neill SD.** 2002. *Mycobacterium bovis* infection and tuberculosis in cattle. *The Veterinary Journal* 163:115-127.

**Rodwell TC, Kriek NP, Bengis RG, White IJ, Viljoen PC, Bengis RG and Boyce W.M.** 2001. Prevalence of bovine tuberculosis in African buffalo at the Kruger National Park. *Journal Wildlife Diseases*, 37 (2):258-64.

**Rothel JS, Jones SL, Corner LA, Cox JC and Wood PR.** 1990. A sandwich enzyme immunoassay for bovine IFN $\gamma$  and its use for the detection of tuberculosis in cattle. Australian Veterinary Journal 67 (4):

**Ryan PC.** 1997. Public Health Notes: Tuberculosis in circus elephants. Southern California Veterinary Medical Association

**Sambrook J, Fritsh EF and Maniatis T.** 1989. Molecular Cloning: A Laboratory manual Vol.1, Cold Spring Harbor Laboratory Press, Cold Spring Harbor, NY.

**Skuce RA, Brittain D, Hughes MS, Beck LA and Neill SD.** 1994. Genomic fingerprinting of *Mycobacterium.bovis* from cattle by restriction fragment length polymorphism analysis. Journal of Clinical Microbiology, 32 (10):2387-2392.

**Song J.** January 29 2001. Rhino at L.A. zoo may have died of tuberculosis. Los Angeles Times.

**Spitznagel J.** 1989. Mechanisms of microbial diseases. Chapter 22, 303-316.

**Tanner M and Michel AL.** 1999. Investigation of the viability of *Mycobacterium bovis* under different environmental conditions in the Kruger National Park. Onderstepoort Journal of Veterinary Research, 66:185-190.

**Tizard IR.** 1992. Veterinary Immunology-An Introduction. 6<sup>th</sup> edition-WB Saunders Company. Chapter 29 & 12.

**Tsumoto K, Ejima D, Kumagai I and Arakawa T.** 2003. Practical considerations in refolding proteins from inclusion bodies. Protein Expression and Purification, 28: 1-8.

**Vardaman TH and Larsen AB.** 1964. The complement fixation test for detecting tuberculosis in cattle. American Journal of Veterinary Research, 25:690-692.



**Wallace R, Carriere J, Diena BB and Greenberg L.** 1968. The bentonite flocculation test in the serology of tuberculosis. Detection of tuberculosis in cattle. *Can. Journal Microbiology*, 14:887-890.

**Whiteside TL.** 2002. Review: Cytokine Assays. *Biotechniques* 33: S4-S15.

**Wildlife Tuberculosis Study Group.** 2001. <http://wildlifetb.greensponsors.com>.

**Wood PR, Rothel JS, Mcwaters PGD and Jones SL.** 1990. Production and characterisation of monoclonal antibodies specific for bovine gamma-interferon. *Veterinary Immunology and Immunopathology*, 25:37-46.

**Wood PR, Corner LA and Plackett P.** 1990. Development of a simple, rapid invitro cellular assay for bovine tuberculosis based on the production of  $\gamma$ -interferon. *Research in Veterinary Sciences*, 49:46-49.

**Wood PR, Corner LA, Rothel JS, Baldock C, Jones SL, Cousins DB, McCormick BS, Francis BR, Creeper J and Tweddle NE.** 1991. Field comparison of the Interferon-gamma assay and the intradermal tuberculin test for the diagnosis of bovine tuberculosis. *Australian Veterinary Journal*, 68 (9):286-290.

**Wood PR, Corner LA, Rothel JS, Ripper JL, Fifis T, McCormick BS, Francis B, Melville L, Small K, DeWitte K, Tolson J, Ryan TJ, DeLisle GW, Cox JC and Jones SL.** 1992. A field evaluation of serological and cellualr diagnostic tests for bovine tuberculosis. *Veterinary Microbiology*, 31:71-79

**Wood PR and Rothel JS.** 1994. Invitro immunodiagnostic assay for bovine tuberculosis. *Veterinary Microbiology* 40:125-135.

**Wood PR and Jones SL.** 2001. BOVIGAM™: An invitro-cellular diagnostic test for bovine tuberculosis. *Tuberculosis (Edinburgh)*, 81 (1-2):147-55.

University of Pretoria etd – Morar, D (2005)

**Yugi H and Nozaki C.** 1972. Serologic diagnosis of bovine tuberculosis. American Journal of Veterinary Research, 33:1377-1384.