

Inbound process design and improvement of after sales parts
from local suppliers and import freight

by

GERALD JOHANNES
29058172

Submitted in partial fulfillment of the requirements for the
degree of

BACHELORS OF INDUSTRIAL ENGINEERING

in the

FACULTY OF ENGINEERING, BUILT ENVIRONMENT AND INFORMATION
TECHNOLOGY

UNIVERSITY OF
PRETORIA

2012

Executive Summary

Toyota South Africa was established in 1961 and has sold more vehicles than any other car manufacturer in South Africa. Due to the rising sales figures of Toyota the need for parts also increased which means that Toyota's parts distribution warehouse was outdated and limited in space.

Toyota designed and built a new parts distribution warehouse which is situated in Kempton Park. Production started on 2nd April 2012 in the new 42 000 square meters warehouse. This new warehouse was brilliantly designed with the best techniques and equipment available, but with a new beginning there are also new challenges.

Management has identified bottlenecks in the inbound system which are due to poor planning techniques. This leads to inaccurate space requirements which result in bottlenecks and imbalanced manpower as well as handling unit alignment. Management requires an inbound system study that will focus on data management, which will manipulate current data obtained from SAP as the main source to aid them in making strategic decisions regarding the alignment of manpower, space utilization and material handling units.

This document provides all the steps taken to manage the project efficiently with selected project management techniques. While executing the project, numerous quality management strategies and techniques are used to ensure reliable and high quality deliverables at the close out stage of the project.

The solution will give new alternatives to their current working and operating methods so that the best methods can be implemented to exclude errors in the system and to save on operating costs and time.

Abbreviations

ASN	Advanced Shipping Notice
B/O	Back Order
DDD	Delivery Due Date
ETA	Estimate Time of Arrival
GRV	Goods Received Voucher
Heijunka	Level out the workload
JIT	Just in Time
KAIZEN	Continuous Improvement
KP	Key Parts
KPI	Key Performance Indicator
L/T	Lead Time
MHE	Material Handling Equipment
MUDA	Waste
POQ	Production Order Quantity
SAP	Special Assistance Plan
S/R	Service Rate
TAM	Toyota Astra Motors
TKM	Toyota Kirloskar Motors
TMC	Toyota Motor Corporation
TMT	Toyota Motor Thailand
TSAM	Toyota South Africa Motors
WIP	Work In Process

Table of Contents

Executive Summary	1
Abbreviations	2
Chapter 1: Introduction	6
1.1 Background	6
1.2 Problem Statement	7
1.3 Project Aim and Scope	8
Chapter 2: Literature Review	9
2.1 Introduction	9
2.2 Value Chain	10
2.3 Warehouse Inbound Operations	11
2.3.1 Mission of the inbound system	11
2.3.2 Methods and Process for managing inbound merchandise	11
2.3.3 Warehouse inbound processes	13
2.3.4 Inbound Activity	14
2.3.5 Nature of part arrival process	14
2.3.6 Queuing System	15
2.3.7 Capacity Requirements	15
2.3.8 Material Handling Equipment	16
2.3.9 Supplier and Production Scheduling	16
2.3.10 Data gathering techniques	18
2.3.11 Data analysis and solution development techniques	20
2.3.12 Work Measurement	21
2.3.13 Cost Impact and Payoff Analysis	21
2.3.14 Manpower requirements	22
2.3.15 Work Measurement techniques	22

2.3.16	Data Mining from SAP	23
Chapter 3:	Current Warehouse operations	24
3.1	Forecasting	24
3.1.1	Long Term	24
3.1.2	Short Term	24
3.2	Planning.....	26
Past.....		26
Present.....		26
3.2.1	Receiving	30
3.2.2	The Current Status of Procurement.....	31
Chapter 4:	Areas for Improvement	33
4.1	Receiving.....	34
4.2	Binning	34
4.2.1	Management.....	38
4.3	Proposed Ideal Supply chain with KAIZEN and JIT	40
5	Conclusion	46
6	References.....	47

Table of Figures

Figure 1: Porter's Value Chain (Langley et al, 2008)	10
Figure 2: The Simulation model flow chart of storage transactions in AVS/RS. (Ekren & Heragu, 2010: 8)	12
Figure 3: Modern Warehousing Operations. (John et al, 2002)	13
Figure 4: Parts Arrival in queues (Chase et al., 2006: 294).....	14
Figure 5: Typical Dashboard program to monitor the process. (http://www.proteussafture.com)	22
Figure 6: Handling units received, processed and WIP on specific day.....	23
Figure 7: Procurement Lead Time	24
Figure 8: Order Cycle	25
Figure 9: Delivery Due Dates	25
Figure 10: All the deliveries that were made and should have been made on 20.06.2012, Data from SAP.	27
Figure 11: Continue from Figure 11	28
Figure 12: Extracting data from SAP to Excel	29
Figure 13: Achieve daily delivery.....	31
Figure 14: KPI of Big Parts Receiving Area.	32
Figure 15: Simulation of Large Receiving Parts.....	35
Figure 16: Current Binning vs. Binning on Target.....	37
Figure 17: Manpower Assignment Board.....	39
Figure 18: Local Procurement Operation	40
Figure 19: Before and after Heijunka	41
Figure 20: Toyota Logistics System	43
Figure 21: Lead Time before and after KAIZEN	44
Figure 22: Work Load before and after Heijunka.....	45

Chapter 1: Introduction

1.1 Background

Toyota South Africa Motors (TSAM) have invested R363-million in a new parts distribution warehouse, to serve car manufacturers' local and regional markets. The warehouse is located near the OR-Tambo International airport and employs over 800 people. It's being developed in two phases, with the first facility of 42 000 square meters opened to full production on the 2nd of April 2012. The second phase of the warehouse, scheduled for completion by 2015, will take the total area of the facility to 80 000 square meters. This new facility serves over 200 Toyota dealerships in South Africa and also exporting parts to 56 countries.

The focus of the project will be on the inbound system of the new parts distribution warehouse. This warehouse is utilised to store all after-sales vehicles parts that are distributed to Toyota dealers across South Africa. Management has identified various bottlenecks on the inbound system which they need to eliminate by putting models into place, which will aid them in their decision making process and ultimately eliminate the problem that causes the bottlenecks. Addressing this problem is very important because any error that occurs at the inbound side of a warehouse will ultimately result in faulty parts being delivered to dealers. This will damage the image of a well-established and known for quality brand Toyota.

1.2 Problem Statement

The inbound manager at the New Toyota NPDC (National Parts Distribution Centre) has difficulty to plan the capacity of incoming parts for the next day (n+1); the planning includes the following:

- Part quantities
- Part volumes
- Handling unit allocation
- Part to handling unit conversion
- Manpower allocation
- Machine allocation

The process of planning currently involves downloading a vast amount of data which is obtained from SAP and then sorting and manipulating it to create understandable information. This data is then used to create useful information for the inbound manager to plan ahead as well as to measure against current KPI's.

This process happens to sometimes be neglected due to the wasted time spent on obtaining the data. The difficulty in planning is caused by non-standardised delivery from the suppliers, which causes confusion and a lot of time is wasted on sorting and inspection. The consequences are that manpower and machine availability are unbalanced as well as clogged inbound holding and part processing areas.

1.3 Project Aim and Scope

The aim of this project is to analyse and improve the NPDC's next day planning techniques vis-à-vis the parts received from import and local suppliers.

The following aspects will be addressed to achieve the project aim:

- Analyse the current warehouse inbound process starting with the receiving process and ending with the actual binning process.
- Create an effective planning tool to minimize the time spent to plan next day deliveries.
- Improve and standardize supplier's delivery and packing methods.
- Analyse and optimise the receiving of the parts and their conversion into handling units.
- Identify and improve key problems, constraints and limitations in the operations.
- Analysing and improving the alignment of manpower, machines and handling units.

Create a tool to measure current operations against established Key Performance Indicators (KPI).

Chapter 2: Literature Review

2.1 Introduction

It is necessary to familiarize oneself with the warehousing environment before a problem of this nature can be addressed holistically. This is needed to understand where the problem originated from and which of the warehouse functions will be affected by creating a suitable solution for the problem at hand. It is important for an engineer to keep up to date with the latest methods, processes and designs related to his respective industry in order to add competitive value added services. Before applying the latter, the engineer would firstly have to perform extensive research on the engineering principles, techniques and designs to broaden his understanding and knowledge relating to the relevant project. The purpose of this literature study is to identify current methods, tools and techniques used in the industry and comparing them to those currently used at Toyota. Although Toyota has predefined methods, processes and techniques, many of these are not fully implemented yet and gaps are identified continuously by their Kaizen operations.

A detailed literature study was therefore conducted on the Value Chain and the warehouse inbound operations consisting of the inbound process and the Material Handling Equipment, due to its direct relationship to the problem statement.

Further literature was researched on techniques to determine the next day deliveries which include: Scheduling and Planning techniques, Data gathering techniques, Data analysis and solution development techniques and Manpower and MHE alignment techniques.

2.2 Value Chain

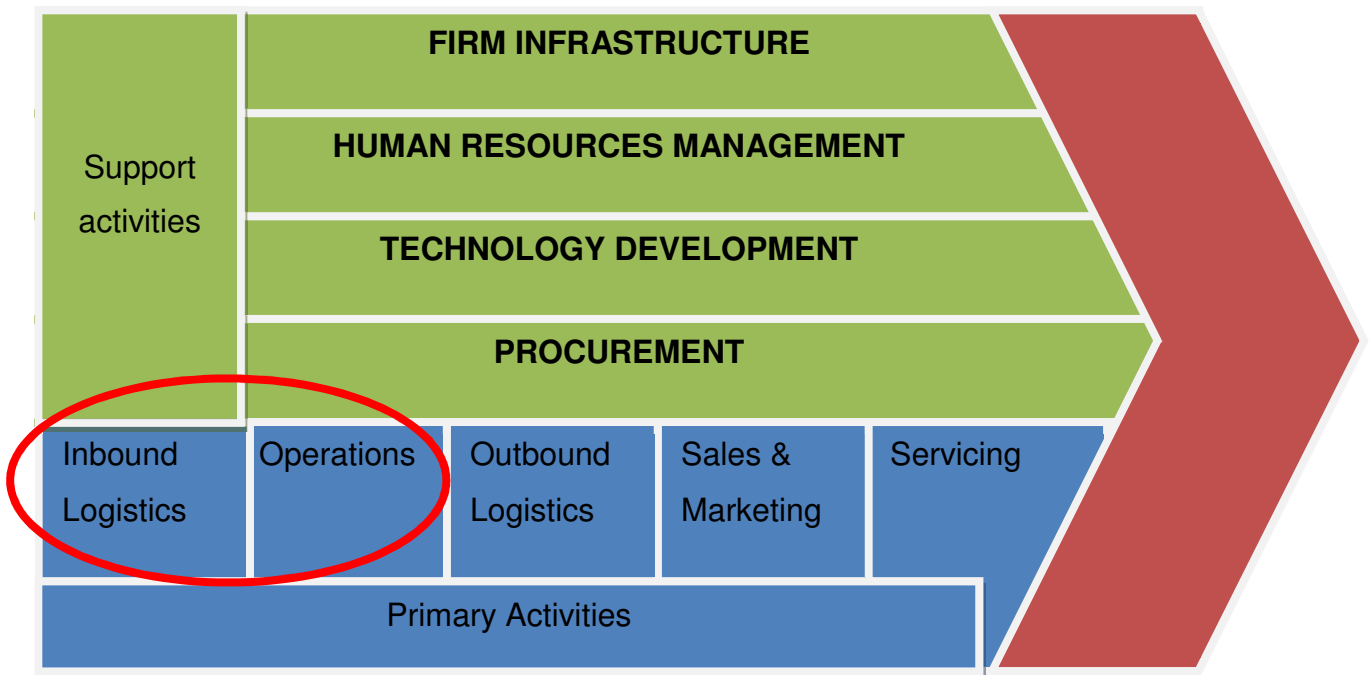

Figure 1: Porter's Value Chain (Langley et al, 2008)

The Value Chain is used to define the core competencies of the organization. The problem persists in the Inbound Logistics department which is then transferred to its operations. By creating better tools and techniques in the inbound logistics, the operations of the process can be improved. The value chain illustrates clearly that if a problem appears at the inbound logistics, then that error will persist all the way through the value chain which can be very harmful to any organization, hence showing the importance of rectifying the problem.

2.3 Warehouse Inbound Operations

2.3.1 Mission of the inbound system

The inbound system of a warehouse plays a major role in a company's supply chain. The mission of the inbound system is to move products from one step to the next without altering or damaging the products basic form (Tompkins et al., 2010: 387).

Inbound opportunities include:

1. Predicting the products inflow – successfully predicting the products arrival time and quantity so that man, machines and handling units can be fully utilized and aligned.
2. Increasing productivity – an important part of the inbound system is the receiving accuracy going along with the effective use of space, manpower and machines. The objective does not imply a lack of productivity over the direct labour or machines but the timing and doing it right the first time.
3. Space and time utilization – the time it takes to determine which product goes where, and staging the product at the right position for the inspection and binning process to avoid double handling.

2.3.2 Methods and Process for managing inbound merchandise

In today's warehouse environments, customers aim to handle materials more efficiently and minimize unnecessary material handling to reduce cycle times, inventory and handling costs (Heitner et al., 2009). Figure 3 illustrates a process flow of a typical inbound operation.

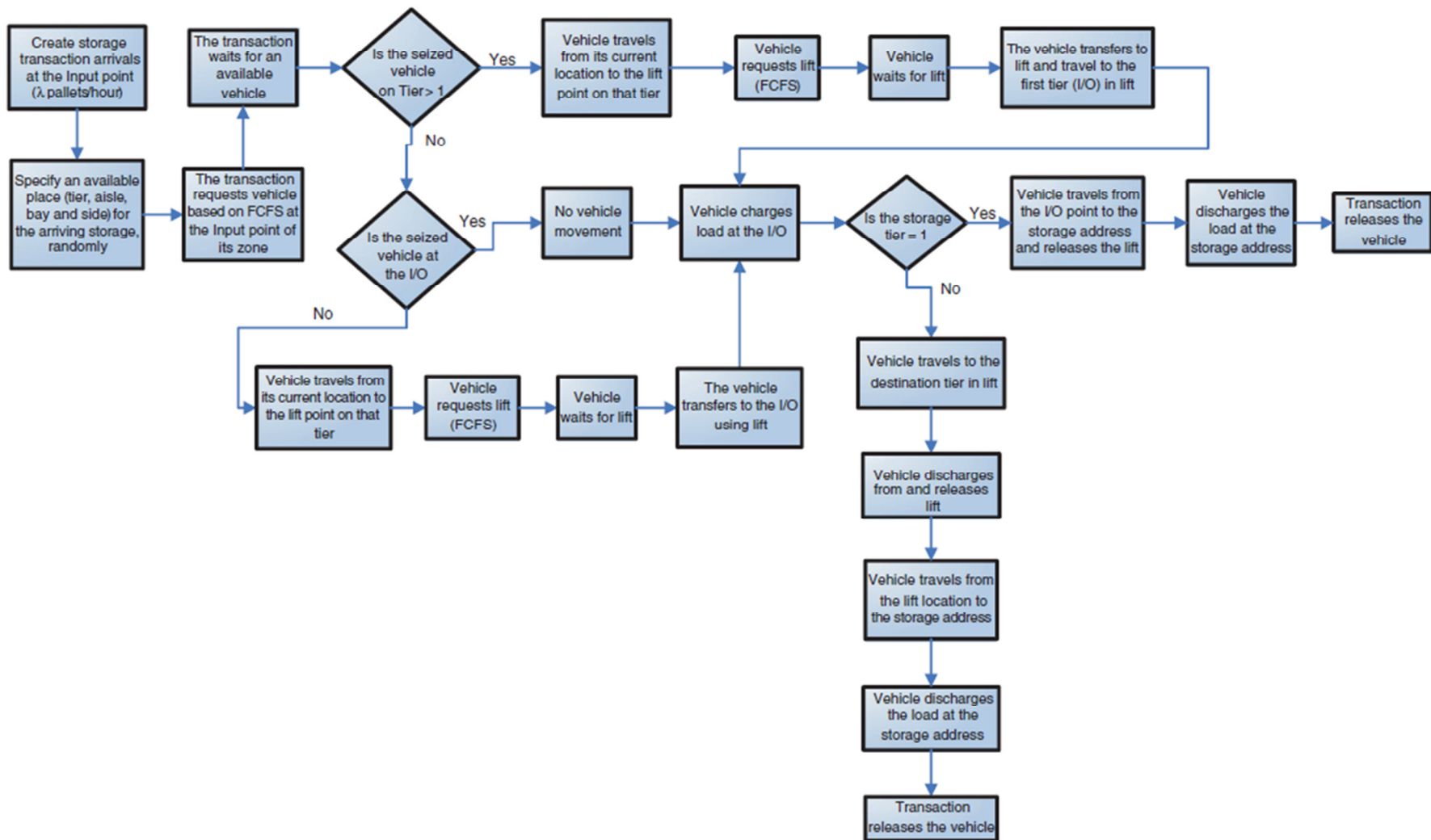

Figure 2: The Simulation model flow chart of storage transactions in AVS/RS. (Ekren & Heragu, 2010: 8)

2.3.3 Warehouse inbound processes

The flow of items through the inbound system can be divided into several distinct phases, or processes.

1. *Receiving* – parts are received at the warehouse in bulk or singular. The parts are unloaded and staged for inspection.
2. *Inspection and quality control* – the parts are counted and the quality is checked. The part must be of a high quality and undamaged, because the parts go to customers, it is heavily regulated.
3. *Repackaging* – The parts are repacked from their bulk format into specific handling units for storage. Each part has a specific storage quantity and type for optimal space utilization. Relabeling is done when products are received without markings that are readable by systems or humans for identification purposes.
4. *Putaway* – The parts are staged for the binning process and then binned into its allocated binning location.
5. *Storage* – Storage can consist of different size bins. The size and quantity of the storage parts determine the form of the storage container and also the handling characteristics of the part.

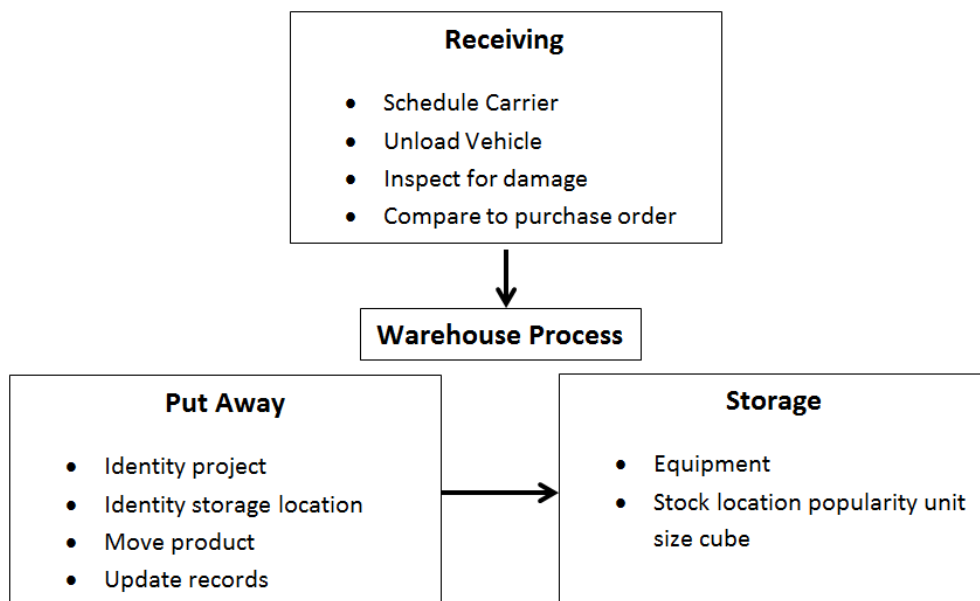

Figure 3: Modern Warehousing Operations. (John et al, 2002)

2.3.4 Inbound Activity

Pallets of parts are delivered via trucks at a distribution centre. Each truck shipment is labelled with an advanced shipping notice (ASN). The ASN contains various information about the product delivery, the type of product and also the quantity of units. Common handling units are normally in the form of pallets. There are various parameters in the Inbound Activity. These parameters include (Peters et al., 2001: 1002):

- Trucks per day
- Hour the truck arrived
- ASN's per truck
- Pallets per truck
- SKU's per ASN
- Units per SKU
- Product storage area
- Cartons per pallet

2.3.5 Nature of part arrival process

A part arriving at a warehouse follows a specific pattern. The pattern can be broken up into various sections and sub-sections.

The arrival rate of the parts can follow different distributions:

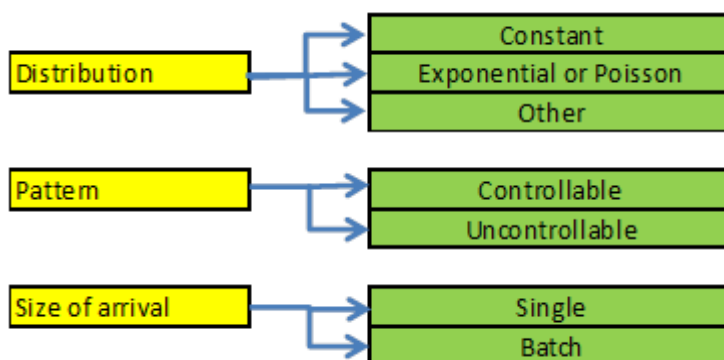

Figure 4: Parts Arrival in queues (Chase et al., 2006: 294).

Arrival Pattern – The arrival pattern of the system is controllable with arrivals directly proportionally to the orders, but the arrivals could be constant, exponential or Poisson distributed according to season or new models available.

Size of arrival – Depending on the type of part, the size of the arrival can be as a single part, usually large parts. Most of the parts come as a batch, normally with a minimum order quantity, these are mostly fast moving parts, bulk storage or small parts.

2.3.6 Queuing System

Parts that arrive at a warehouse are placed in a queue to be processed further. Depending on the length of the line and the number of lines available will determine the time a part will have to wait before being processed.

There are different queuing disciplines in which a warehouse can operate on namely:

- First come, first served
- Shortest processing time
- Fast moving parts first
- Emergencies first
- Limited needs
- Other

The queuing delay is caused by bottlenecks, due to unforeseen arrival rates of the parts, lack of planning and alignment.

2.3.7 Capacity Requirements

In determining capacity requirements, we must address the demands for individual product lines, individual plant capabilities, and allocation of production throughout the plant network.

Typically this is done according to the following steps:

1. Forecasting techniques can be used to predict sales for each product.
2. To meet product line forecasts, equipment and labour requirements need to be calculated.
3. The availability of project labour and equipment in the long run.

2.3.8 Material Handling Equipment

A warehouse inbound system requires various material handling equipment (MHE) to move and store the parts. Each handling unit requires a specific type of equipment to move it from one area to its designated location.

Typical MHE used in a warehouse:

- Pallet Trucks – a pallet truck is designed to handle pallets. The truck can either be electric or hydraulic hand. There are manual or automatic trucks available, these trucks forks fit perfectly into the pockets of a pallet (Lane 2004).
- Forklifts – A forklift can either be electrically driven or driven by combustion engine. Normally when a forklift is operated inside a warehouse it is electric powered to avoid gas fumes filling the warehouse. These forklifts are used to unload trucks and to move the products on to a conveyor.
- Reach Trucks – These trucks operate the same as a forklift but are much smaller and narrower and are used to work within the storage isles. They are also designed to reach very high areas.
- Binning Trolleys – Binning trolleys are mostly hand pulled for lighter products to be moved from the receiving end to its binning location.
- Order pickers – Order pickers are used to pick up heavy bulk parts.
- Pallet jacks – A pallet jack is used to move parts on a pallet over short distances. The pallet jack's lifting mechanism can either be manual or battery powered.
- Conveyors - Used to move parts frequently over a fixed path between points.

2.3.9 Supplier and Production Scheduling

The supplier delivery schedule is very important to be able to productively schedule the process. The whole production process begins with the delivery of the parts and when the delivery is on schedule the production can also be scheduled and further planning can be done. The following approaches are various scheduling methods that could be used:

2.3.9.1 Manual Scheduling

Manual scheduling is done during the production process. The progress of the production process is reported to management and management then draws up a schedule to meet the due dates.

This scheduling technique is not a good scheduling method for a big company such as Toyota. The scheduling method causes long lead times, idle times, overtime work and backlog.

2.3.9.2 Scheduling by Project Management Tools

The project management tool is widely used in many production companies. To schedule diverse workloads the Engineer to Order tool is very popular. The critical path method however creates production schedules that are meaningless because of the long waiting time for a part to be processed.

2.3.9.3 Enterprise Resource Planning

The Enterprise Resource Planning (ERP) method improved the production system of many manufacturing companies. Information can be handled very easily with this system and it also improves the efficiency of the business operations.

2.3.9.4 Lean Production System

Lean Production is a set of activities that are designed to achieve high-volume production using minimal inventories of raw materials, work-in-process, and finished goods. The lean production system uses methods like focused factory networks, group technology, quality at the source, Kanban production, JIT production and uniform plant loading also called the Heijunka method.

Toyota uses the lean production system, but it is not running at its utmost potential. The new parts distribution warehouse brought new challenges with it and one of the biggest challenges is to bring the lean production system to its maximum potential performance with accent on JIT production.

To achieve this goal the suppliers need to make use of standardized material handling units. The warehouse has standard pallet quantities in which the supplier should deliver the parts in instead of the current loose parts or half pallets.

The ultimate goal in getting the inbound system in sequence and on schedule is to create minimum order quantities in which the supplier has to deliver. With this method in place, manpower, machines and handling units can be aligned and scheduled.

2.3.10 Data gathering techniques

Automated status control of material requires that the location, amount, origin, and schedule of material be achieved automatically. This objective is in fact the function of automatic identification and communication technologies, technologies that permit real-time, nearly flawless data collection and communication. Examples of automatic identification and communication technologies at work include:

- A vision system reading inter-operating labels to identify the proper destination for a carton travelling on a sortation conveyor.
- A laser scanner to relay the inventory levels of a small parts warehouse to a computer via radio frequency communication.
- A voice recognition system to identify parts received at the receiving dock.
- A radio frequency (RF) tag used to permanently identify a tote pan or pallet.

The list of automatic identification and recognition technologies is expanding and includes:

- Bar Codes – consist of a series of black and white bars with a specific sequence representing letters or numbers. A bar code is a worldwide language and contains important information about a product. Bar codes can be used for almost anything from product pricing in supermarkets to inventory control in a warehouse. Bar codes are scanned by either an automatic or handheld bar code scanner which sends the bar code information to a computer. The information on the bar code typically contains:

- | | |
|--------------------|-----------------|
| • Storage bin | • Staging area |
| • Type of Material | • Shipment |
| • Quantity | • Pick wave |
| • Delivery | • Handling unit |

- Optical Character Recognition – optical characters can be read by humans and by machine. The system reads alpha-numeric data which is also readable by humans and can be interpreted by both. The optical character recognition (OCR) system has the same function as bar codes, they are also scanned by hand held scanners. One disadvantage the OCR system has against the bar coding system is that it operates at slower reading rates. The OCR system works very well in a warehouse environment where humans and machine- readable capabilities are required.
- Radio Frequency Tag – The radio frequency identification (RFID) tag encodes data on a chip that is encased in a tag. A special antenna is used to pick up the tag and decode it by a tag reader. Radio frequency tags eliminate the use of hand held scanners and can read and decode from up to 10 meters away. These tags can be programmable or permanently coded and are very useful in harsh environments where printed codes may fade away or fall off.
- Magnetic Strip – A magnetic strip can store a large quantity of information in a small space. The strip is commonly used at the back of credit cards and bank cards. The strip is readable in any condition through dirt or grease, and the data on the strip can easily be erased or changed. One disadvantage is that the strip must read by contact which could slow down high-speed sortation applications. The magnetic strip system is more expensive than a bar code system.
- Machine Vision – The machine vision takes pictures of the product codes and objects, and then sends the pictures to a computer for interpretation. The machine vision system works with excellent accuracy at moderate speeds. The accuracy of the system depends strictly on the quality of the light and does not need contact with the object to be read. The machine vision is still a costly system but the cost however is decreasing (Tompkins et al 2010).

Other Data Gathering techniques include:

- Experiments/clinical trials – not applicable
- Observing and recording
- Obtaining relevant data from management information systems

- Administering surveys with closed-ended questions
- Interviews – not applicable
- Questionnaires – not applicable
- SAP Exports

SAP is a widely used management system in the warehousing industry where real time data can be obtained from. SAP is a multi-functional program and very accurate.

2.3.11 Data analysis and solution development techniques

2.3.11.1 Process flow analysis

Better methods for producing and delivering a product or service are discovered by viewing and analysing the transformation process as a sequence of steps connecting inputs to outputs.

It can also be used to:

- Find repetitive operations
- Identify bottlenecks
- Show the alignment between man, machine and handling units

2.3.11.2 Simulation

Simulation is representing a system in the form of a computer model. The model will be able to imitate the analysed process in order to determine how the system would react to various conditions. A new design can also be simulated to determine the feasibility of the design and the number of flaws and errors. The simulation however, does not provide an optimum solution (Tompkins *et al.*, 2010: 702).

Some of the major reasons for using simulation are

1. Making determinations when a mathematical solution cannot be obtained easily or at all.
2. Selling the facilities plan to management.
3. Explaining to operational personnel how a proposed system will function.
4. Testing the feasibility of a proposed system.
5. Validating mathematical models.
6. Predicting the impact of a change in the physical system, the environment, or operating procedures.

7. Analysing a system at a level of detail beyond what a mathematical model is able to describe (Tompkins et al., 2010: 702).

2.3.12 Work Measurement

The ultimate purpose of work measurement is to set up time standards for a specific job. Such standards are necessary for four reasons: (Chase, Jacobs & Aquilano, 2006: 190)

1. To schedule work and allocate capacity – The processing time to do a specific job is crucial for all scheduling approaches.
2. To provide an objective basis for motivating the workforce and measuring workers' performance – Where there are output based incentives plans employed, measured standards are particularly critical.
3. To bid for new contracts and to evaluate performance on existing ones – There are two questions that can be asked in new contracts such as “Can the job be done?” and “How will it be done?” to presume the existence of standards.
4. To provide benchmarks for improvement. Benchmarking is a very important aspect in the production environment to compare the company's current performance and standards to other similar companies (Chase, Jacobs & Aquilano, 2006: 190).

2.3.13 Cost Impact and Payoff Analysis

Decision Trees – Decision trees can be used to identify the risks of this problem and ultimately to make the right decisions.

Stakeholder Analysis – there are normally five types of stakeholders namely: customer, stockholder, employees, suppliers and the community. The solution to this problem should benefit all the stakeholders in the system.

Balanced Scorecard – Through the use of a balance scorecard the progress of the project can be recorded. The balance scorecard can also be used to set up goals and to measure employee relations and customer service.

Process Dashboards – The process dashboard provides a summary of the performances for a specific process. It monitors the progress through colour-coding and trend lines. This technique is chosen to be suitable to aid with the solution from the problem definition.

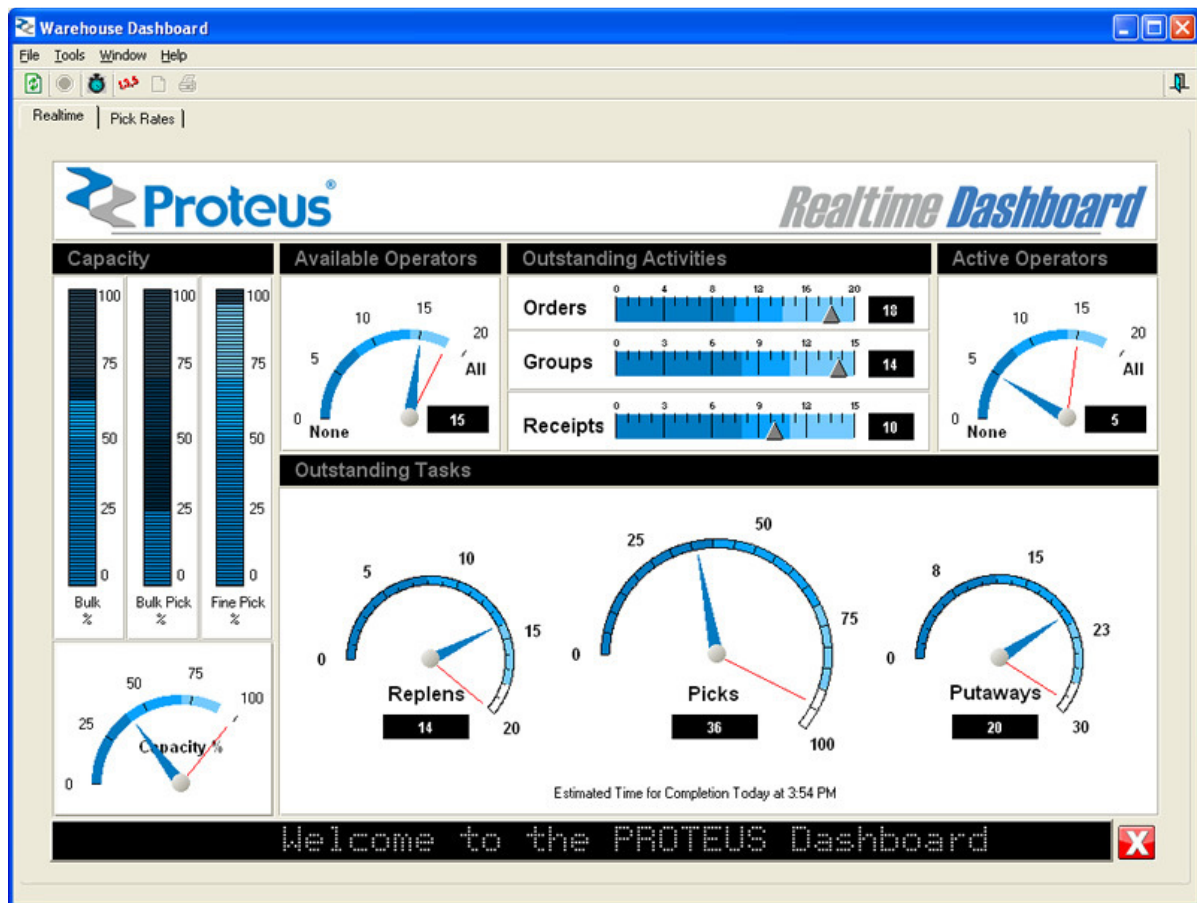

Figure 5: Typical Dashboard program to monitor the process. (<http://www.proteussافتure.com>)

2.3.14 Manpower requirements

Distribution centres require workers to perform various operations. Workers are needed in the receiving area to de-van goods received, inspect, quality control, convey and bin the parts. The manpower data file allows you to set finite capacity constraints on each of the worker types. This means that you can define operator types, and specify the manpower needed for each shift.

2.3.15 Work Measurement techniques

Graphs and charts can be used to compare the current workflow to the KPI. Percentages could also be used to compare month to month. Figure 7 is an example of a graph for the local Bulk Storage receiving, processing and work in process left for that day.

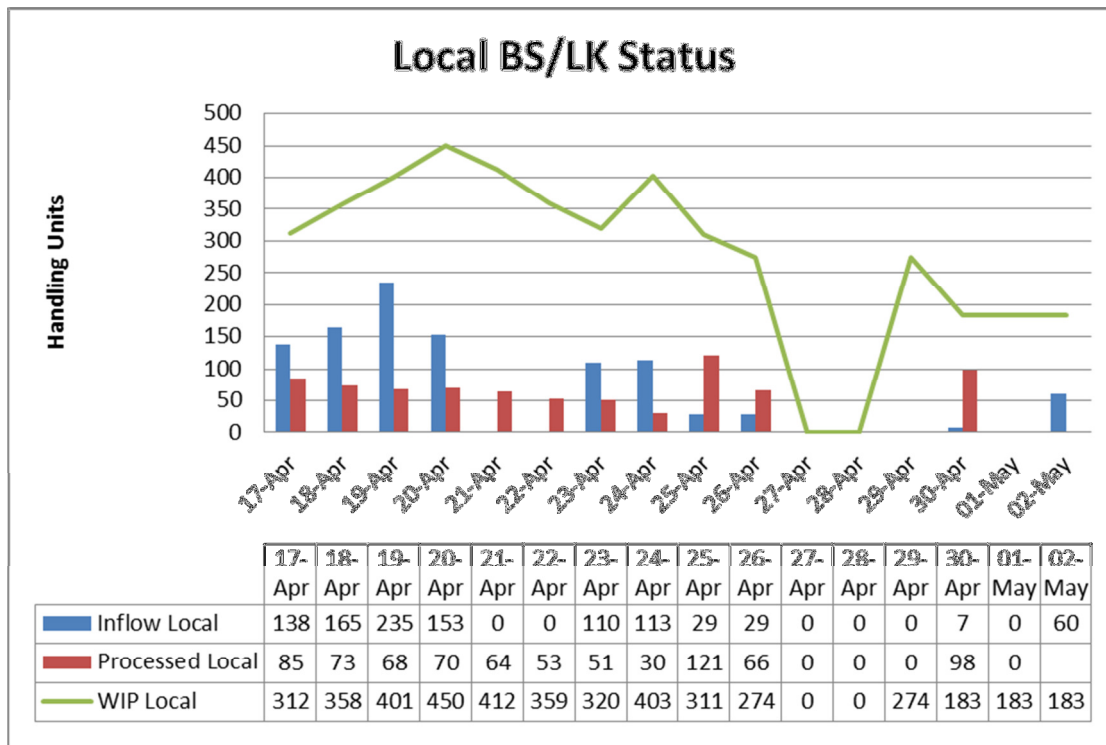

Figure 6: Handling units received, processed and WIP on specific day.

2.3.16 Data Mining from SAP

SAP Warehouse Management is a computer software program that organizes and manages warehouse operations for timely and effective processing of the logistics system. The SAP Warehouse Management system provides automated support in assisting in the processing and maintenance of current stock inventories. WM supports warehousing processes by making it possible for you to:

- Define and manage complex warehousing structures
- Optimize material flow using advanced put away and picking techniques
- Process goods receipts, goods issued and stock transfers quickly and easily

Data can be mined from SAP into different programs like:

- Microsoft Excel
- Microsoft Access
- Matlab

Chapter 3: Current Warehouse operations

3.1 Forecasting

3.1.1 Long Term

Toyota uses the Past Average Forecasting method based on demand between 6-12 months rolling, meaning that every month an updated 6-12 months forecast is calculated. This forecasting method has a variability of 20%.

3.1.2 Short Term

Short term forecasting is also based on demand from month to month deliveries and also on weekly deliveries. Deliveries from local suppliers have a lead time of 7 days from the day they have been ordered and orders from international suppliers have a lead time of 28 days. SAP sends an order to the procurement department when the minimum stocking quantity is reached. The procurement department then sends in the final updated order to the suppliers.

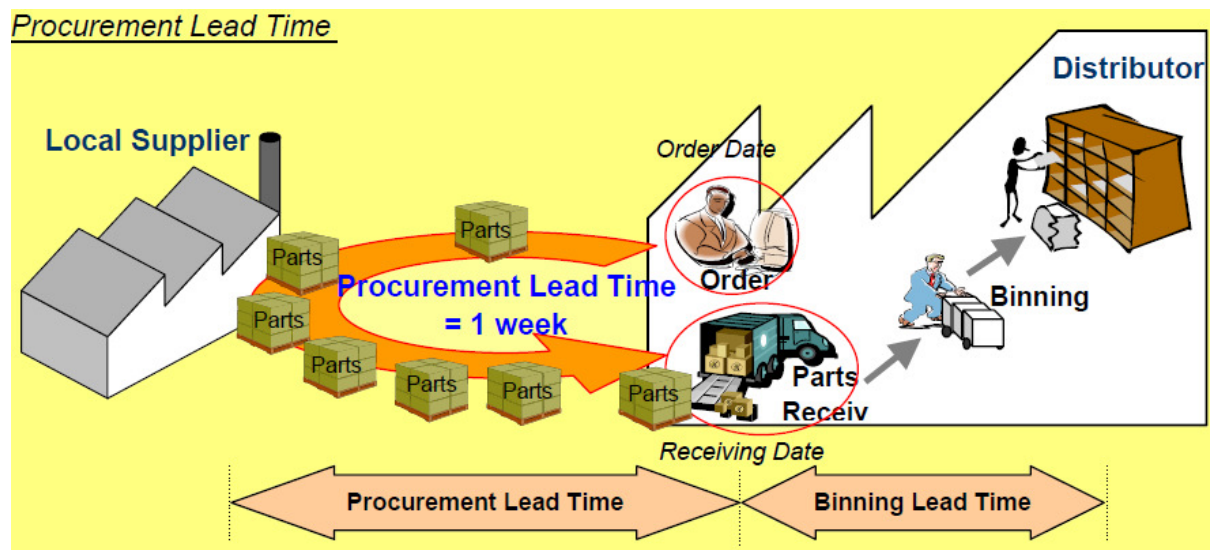

Figure 7: Procurement Lead Time

Procurement Lead Time is a period from placing an order to a local supplier until receiving parts at distributor's warehouse. In case a supplier does not take responsibility to deliver parts to the distributor, procurement lead time is a period from placing an order until shipment is ready to be dispatched at the supplier's warehouse.

Example: Order Cycle = Weekly, Delivery Cycle = Daily, Procurement L/T = 1 Week

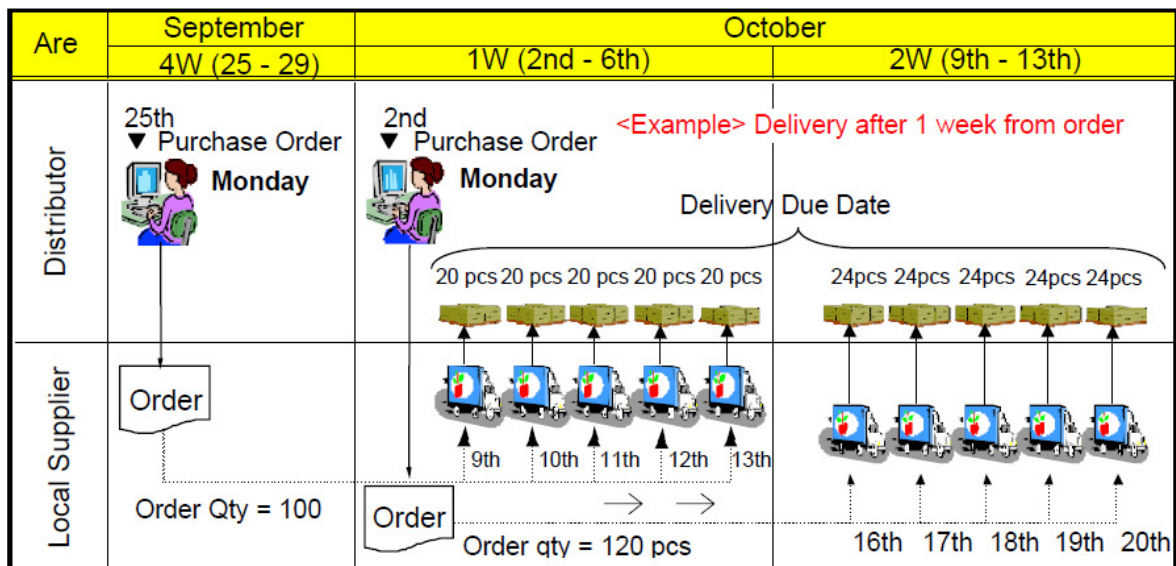
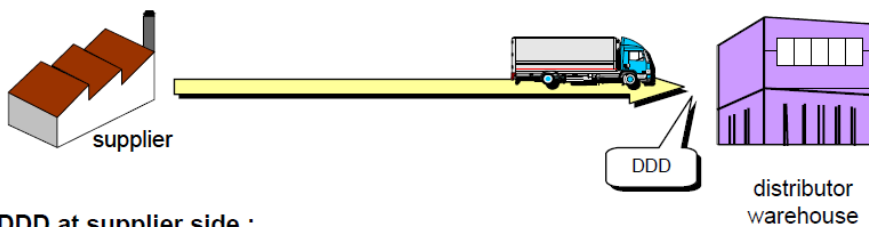

Figure 8: Order Cycle

Delivery Due Date is a delivery plan which is set according to the L/T agreement between distributors and suppliers. There are 2 different definitions for DDD:

*** DDD at distributor side :**
(Truck is arranged by supplier)



*** DDD at supplier side :**
(Truck is arranged by distributor)

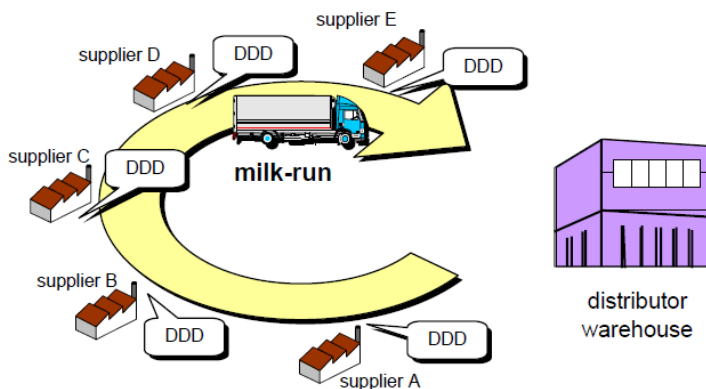

Figure 9: Delivery Due Dates

3.2 Planning

Past

In the past there was no link between the procurement department and the Inbound Operations System. The procurement department made the forecasting on historical data combined with actual demand and just ordered the parts according to their forecasting results without consulting the inbound operations system on the quantity of stock still on hand and also the storage space available. The lack of day to day planning resulted in great backlog in the inbound process.

Present

At present the procurement department works very closely with the Inbound Operations System in planning and forecasting. Day to day planning is made through extracting the next day's deliveries from SAP and exporting it to MS Excel for further simplification as can be seen in Figures 11-13. SAP lists a schedule for a specific day, the list contains the names of all the suppliers that should deliver on that day and each supplier is scheduled into a delivery time slot. It is expected of each supplier to deliver their parts on exactly their scheduled time. The warehouse has different stations for different types of parts such as:

- HL – Heavy Large
- LL – Light Large
- BS – Bulk Storage
- SM – Small & Medium

PO number	PO Item	Delivery	Name	Delivery Date	TimeOfDelivery	Item	Gate In	In Time	Gate Out	Out Time	Material	Description
520399	1	180445735	FEDERAL-MOGUL SEALING SYSTEMS SA	20.06.2012	10:33:23	1		00:00:00		00:00:00	174850770	GASKET,EXH BRAKE
520446		180446044	Top Class Automotive Bearing System	20.06.2012	12:31:00	1	20.06.2012	11:57:15	20.06.2012	12:37:48	0000028020	CYL,SLAVE,6SP
	2	180446044	Top Class Automotive Bearing System	20.06.2012	12:31:00	2	20.06.2012	11:57:15	20.06.2012	12:37:48	A314601007	CYL,SLAVE
668224	8	180446441	SMITHS MANUFACTURING (PTY) LTD	20.06.2012	12:56:03	1		00:00:00		00:00:00	177000L141	CLEANER ASSY, AIR W/ELEMENT
	57	180446239	SMITHS MANUFACTURING (PTY) LTD	20.06.2012	09:56:03	2		00:00:00		00:00:00	8532128020	VALVE
668588	1	180445902	LUMOTECH (SOUTH AFRICA) PTY LTD	20.06.2012	13:02:04	1	20.06.2012	08:04:16	20.06.2012	08:34:27	8156102560	LENS & BODY, RR COMBINATION LAMP, LH
668684		180445493	TOYOTA BOSHOKU SA	20.06.2012	09:00:00	1	20.06.2012	10:20:02		00:00:00	710720K192B4	COVER SUB-ASSY, FR SEAT CUSHION, LH
668685		180445475	TOYOTA BOSHOKU SA	20.06.2012	09:00:00	1	20.06.2012	10:19:51	20.06.2012	11:01:04	676100K090B1	PNL ASY, FR DR RH - B/CAB M/W L/FAB
668686		180445496	TOYOTA BOSHOKU SA	20.06.2012	09:00:00	2		00:00:00	20.06.2012	11:01:08	676300K040B0	PNL ASSY,RR DR RHD P/W PICKFAB LO
	2	180445496	TOYOTA BOSHOKU SA	20.06.2012	09:00:00	1		00:00:00	20.06.2012	11:01:08	676400K030B0	PANEL ASSY, RR DOOR TRIM, LH
668687	1	180445504	TOYOTA BOSHOKU SA	20.06.2012	09:00:00	1	20.06.2012	10:19:42	20.06.2012	11:00:51	676200K040B0	PANEL ASSY, FR DOOR TRIM, LH
668720	2	180445453	SPICER AXLE SA	20.06.2012	15:05:28	1	20.06.2012	09:34:00	20.06.2012	09:54:03	4218105600	GASKET,AXLE HOUSING
	4	180445448	SPICER AXLE SA	20.06.2012	15:05:07	4	20.06.2012	09:33:52	20.06.2012	09:53:20	9008036216	BEARING,TAPPET ROLLER
	5	180445448	SPICER AXLE SA	20.06.2012	15:05:07	3	20.06.2012	09:33:52	20.06.2012	09:53:20	9025007800	PIN
	6	180445448	SPICER AXLE SA	20.06.2012	15:05:07	2	20.06.2012	09:33:52	20.06.2012	09:53:20	9031105620	SEAL,OIL
	7	180445448	SPICER AXLE SA	20.06.2012	15:05:07	1	20.06.2012	09:33:52	20.06.2012	09:53:20	9034105730	PLUG,DIFF FILLER
668725	3	180446264	ROBERT BOSCH PTY LTD	20.06.2012	13:00:47	1	20.06.2012	11:52:39	20.06.2012	12:30:43	4351202200	DISC, FR
668726	1	180446270	GIRLOCK S.A. PTY LTD	20.06.2012	15:30:00	1		00:00:00		00:00:00	0449502100	SHOE KIT,PARKING BRAKE
	2	180446266	GIRLOCK S.A. PTY LTD	20.06.2012	15:33:19	1		00:00:00		00:00:00	049410K010	SPRING KIT,REAR DRUM BRAKE
	3	180446266	GIRLOCK S.A. PTY LTD	20.06.2012	15:33:19	2		00:00:00		00:00:00	049410K040	SPRING KIT,REAR DRUM BRAKE
	4	180446270	GIRLOCK S.A. PTY LTD	20.06.2012	15:30:00	2		00:00:00		00:00:00	049420K080	SPRING KIT
	5	180446270	GIRLOCK S.A. PTY LTD	20.06.2012	15:30:00	3		00:00:00		00:00:00	049430K070	STRUT KIT,REAR DRUM BRAKE
	6	180446270	GIRLOCK S.A. PTY LTD	20.06.2012	15:30:00	4		00:00:00		00:00:00	4744705600	PIN,SHOE HOLDDOWN LH
	7	180446270	GIRLOCK S.A. PTY LTD	20.06.2012	15:30:00	5		00:00:00		00:00:00	4744905600	PIN SHOE HOLDDOWN RH
	8	180446270	GIRLOCK S.A. PTY LTD	20.06.2012	15:30:00	6		00:00:00		00:00:00	4747505600	BRAKE ADJUSTER RH, LH THREAD
	9	180446270	GIRLOCK S.A. PTY LTD	20.06.2012	15:30:00	7		00:00:00		00:00:00	474770N900	ADJUSTER ASSY LH
	11	180446266	GIRLOCK S.A. PTY LTD	20.06.2012	15:33:19	3		00:00:00		00:00:00	4755005601	CYLINDER ASSY, WHEEL (MARK: 7435) ID: 19
	12	180446266	GIRLOCK S.A. PTY LTD	20.06.2012	15:33:19	4		00:00:00		00:00:00	476160N900	WIRE,PARKING BRAKE
668727	1	180446279	GIRLOCK S.A. PTY LTD	20.06.2012	15:41:55	1		00:00:00		00:00:00	049430K050	STRUT KIT,REAR DRUM BRAKE
668731	2	180445960	RAMSAY ENGINEERING	20.06.2012	14:22:42	1	20.06.2012	09:06:43	20.06.2012	09:35:39	7445102050	BOLT,BATTERY CLAMP
668748	1	180445830	LUMOTECH (SOUTH AFRICA) PTY LTD	20.06.2012	11:48:06	1	20.06.2012	08:05:01	20.06.2012	08:34:49	811500K230	HEADLAMP ASSY, LH
668785		180445911	VENTURE	20.06.2012	15:42:06	1		00:00:00		00:00:00	5387602320	LINER, FR FENDER, LH
668803	2	180445415	SPICER AXLE SA	20.06.2012	15:05:00	1	20.06.2012	09:34:54	20.06.2012	09:54:17	043710K082	SPIDER KIT, UNIVERSAL JOINT
668812	1	180446106	FEDERAL MOGUL ENGINE	20.06.2012	07:50:35	1	20.06.2012	10:20:24	20.06.2012	11:21:01	8522233031VP	BLADE FRONT WIPER

Figure 10: All the deliveries that were made and should have been made on 20.06.2012, Data from SAP.

PO number	PO Item	Delivery	ASN Status	Bill of lading	Vendor	ASN Number	Σ ASN Qty	Σ Count Qty	Σ Open Count	Σ GR Qty	Σ Open GR
520399	1	180445735		06181869	L03008	280523	10.000	0.000	10.000	0.000	0.000
520446		180446044	ARRIVED AT GATE	87668	L06012	280691	1.000	0.000	1.000	0.000	0.000
	2	180446044	ARRIVED AT GATE	87668	L06012	280691	1.000	0.000	1.000	0.000	0.000
668224	8	180446441			L19017	949716	15.000	0.000	15.000	0.000	0.000
	57	180446239			L19017	949661	3.000	0.000	3.000	0.000	0.000
668588	1	180445902	ARRIVED AT GATE	279633	L08004	280619	12.000	0.000	12.000	0.000	0.000
668684		180445493	ARRIVED AT GATE	SUBBD14650226	L12034	280393	2.000	0.000	2.000	0.000	0.000
668685		180445475	ARRIVED AT GATE	SUBBD14650226	L12034	280383	7.000	0.000	7.000	0.000	0.000
668686		180445496		SUBBD14650226	L12034	280395	6.000	0.000	6.000	0.000	0.000
	2	180445496		SUBBD14650226	L12034	280395	6.000	0.000	6.000	0.000	0.000
668687	1	180445504	ARRIVED AT GATE	SUBBD14650226	L12034	280399	9.000	0.000	9.000	0.000	0.000
668720	2	180445453	ARRIVED AT GATE	06182721	L02011	280368	10.000	0.000	10.000	0.000	0.000
	4	180445448	ARRIVED AT GATE	06182721	L02011	280367	3.000	0.000	3.000	0.000	0.000
	5	180445448	ARRIVED AT GATE	06182721	L02011	280367	28.000	0.000	28.000	0.000	0.000
	6	180445448	ARRIVED AT GATE	06182721	L02011	280367	20.000	0.000	20.000	0.000	0.000
	7	180445448	ARRIVED AT GATE	06182721	L02011	280367	3.000	0.000	3.000	0.000	0.000
668725	3	180446264	ARRIVED AT GATE	91464611	L04007	280825	2.000	0.000	2.000	0.000	0.000
668726	1	180446270		151188	L07004	280826	10.000	0.000	10.000	0.000	0.000
	2	180446266		151189	L07004	280828	10.000	0.000	10.000	0.000	0.000
	3	180446266		151189	L07004	280828	10.000	0.000	10.000	0.000	0.000
	4	180446270		151188	L07004	280826	10.000	0.000	10.000	0.000	0.000
	5	180446270		151188	L07004	280826	10.000	0.000	10.000	0.000	0.000
	6	180446270		151188	L07004	280826	80.000	0.000	80.000	0.000	0.000
	7	180446270		151188	L07004	280826	120.000	0.000	120.000	0.000	0.000
	8	180446270		151188	L07004	280826	24.000	0.000	24.000	0.000	0.000
	9	180446270		151188	L07004	280826	20.000	0.000	20.000	0.000	0.000
	11	180446266		151189	L07004	280828	10.000	0.000	10.000	0.000	0.000
	12	180446266		151189	L07004	280828	10.000	0.000	10.000	0.000	0.000
668727	1	180446279		151190	L07004	280835	10.000	0.000	10.000	0.000	0.000
668731	2	180445960	ARRIVED AT GATE	06197373	L18017	280645	2.000	0.000	2.000	0.000	0.000
668748	1	180445830	ARRIVED AT GATE	279611	L08004	280579	24.000	0.000	24.000	0.000	0.000
668785		180445911		barloworld	L01025	280629	4.000	0.000	4.000	0.000	0.000
668803	2	180445415	ARRIVED AT GATE	06182721	L02011	280341	27.000	0.000	27.000	0.000	0.000
668812	1	180446106	ARRIVED AT GATE	1005432801	L19003	280724	20.000	0.000	20.000	0.000	0.000

Figure 11: Continue from Figure 11

	Different suppliers and part numbers	Number of pieces delivered	Number of lines delivered
1			
2			
3	Row Labels	Sum of Open Count	Count of Open Count2
4	20.06.2012	28743	1022
5	A.W.FRICTION (PTY) LTD	82	4
6	0446502120VP	55	1
7	0446535260VP	10	1
8	0449105735VP	2	1
9	044910G910VP	15	1
10	ALLIED TRIM COMPONENTS (PTY) LTD.	4	1
11	PZN71F1004PPO	4	1
12	ANROPA (PTY) LTD	51	12
13	4641035230	5	1
14	4641035240	4	1
15	4642005621	4	1
16	4642005730	2	1
17	4642005735	4	1
18	4642005736	3	1
19	4643005730	2	1
20	4643005735	3	1
21	4643005736	3	1
22	464200G900	15	1
23	464200P911	2	1
24	464300P911	4	1
25	AUTO ARMOR STARWASH FRANCHISING(PTY	3	3
26	PZN55X3027	1	1
27	PZN55X3032	2	2
28	BAIRES PLASTICS (PTY) LTD	145	7
29	4260304160	50	1
30	7544302080	10	1
31	7544302100	10	1
32	7544302160	10	1
33	7544302180	5	1

ivotTable Field List

Choose fields to add to report:

- PO number
- PO Item
- Delivery
- Name**
- Delivery Date**
- TimeOfDelivery
- Item
- Gate In
- In Time
- Gate Out
- Out Time
- Count Date
- Count Time
- GR Date
- GR Time
- Material**
- Description

Drag fields between areas below:

Report Filter

Column Labels

Σ Values

Row Labels

7

Delivery Date

Name

Material

Σ Values

Sum of Open...

Count of Op...

Defer Layout Update

Figure 12: Extracting data from SAP to Excel

3.2.1 Receiving

The New Parts Distribution Warehouse can accommodate more than a million parts. The warehouse has also a great turnover in parts receiving and despatching with a value up to R20 million per day. Parts are received locally and internationally.

The receiving process consists of several stages:

Local

The truck arrives from the supplier at the gate, the ASN slip is scanned at the gate and the off-loading is then scheduled according to the set arrival times of trucks on that day, a late truck might have to wait. Trucks are then being routed according to their size and volume. The parts are then off-loaded into the yard according to the storage type indicated on the GRV label (small, large, bulk). The ASN document is signed after the off-loading is completed and also scanned before the truck leaves the gate. The items that were delivered are sorted from the outside temporary staging area to different area rollers differentiated by storage type indicators. Key Parts transfer items are loaded directly onto KP transfer conveyors. Bulk and KP parts are GRV'd on the rollers and labelled with its binning label. Small, Medium and Large parts are unpacked, GRV'd, inspected, labelled and rerouted to their allocated area. The unpacked parts are placed onto sections trolleys and binned.

International

Parts are imported either by air or sea freight, the forwarding agents advise receiving, and TSAM advises them on a delivery time and date. Trucks arrive at the gate and off-loading is scheduled according to the set arrival times of trucks on that day, late trucks may have to wait. Trucks are routed according to their size and volume. GRV shipment and case numbers are processed. The truck off-loads the container at the dock level stations; the loose parts are consolidated onto P-Containers and stacked accordingly. Parts from Kamigo are placed on one side; normally the large parts and parts from Inizawa & Oguchi are stacked at the temporary staging area at JSP/MSP 1. Binning labels are consolidated with respective cases. Modules are taken to respective holding areas, small parts are taken to JSP/MSP 2&3, Airfreight parts are taken to designated staging areas and HME parts are staged directly into

HME1 staging area. Modules are then sorted to respective receiving areas onto conveyors and then unpacked and sorted onto pallets or binning trolleys.

3.2.2 The Current Status of Procurement

The graph below shows the current status of the procurement condition and performance at distributors.

a. Order Cycle and Delivery Cycle

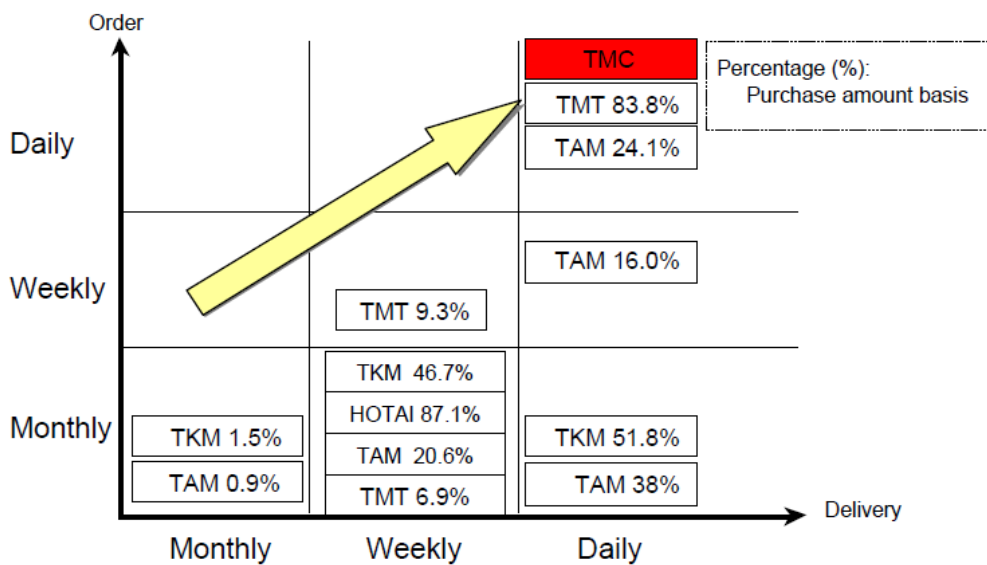

Figure 13: Achieve daily delivery.

Figure 14 shows the KPI's for the input through to the output for the big parts receiving area, these are the parameters according to which the warehouse is designed with the different processing times, number of operators and amount of WIP it can store.

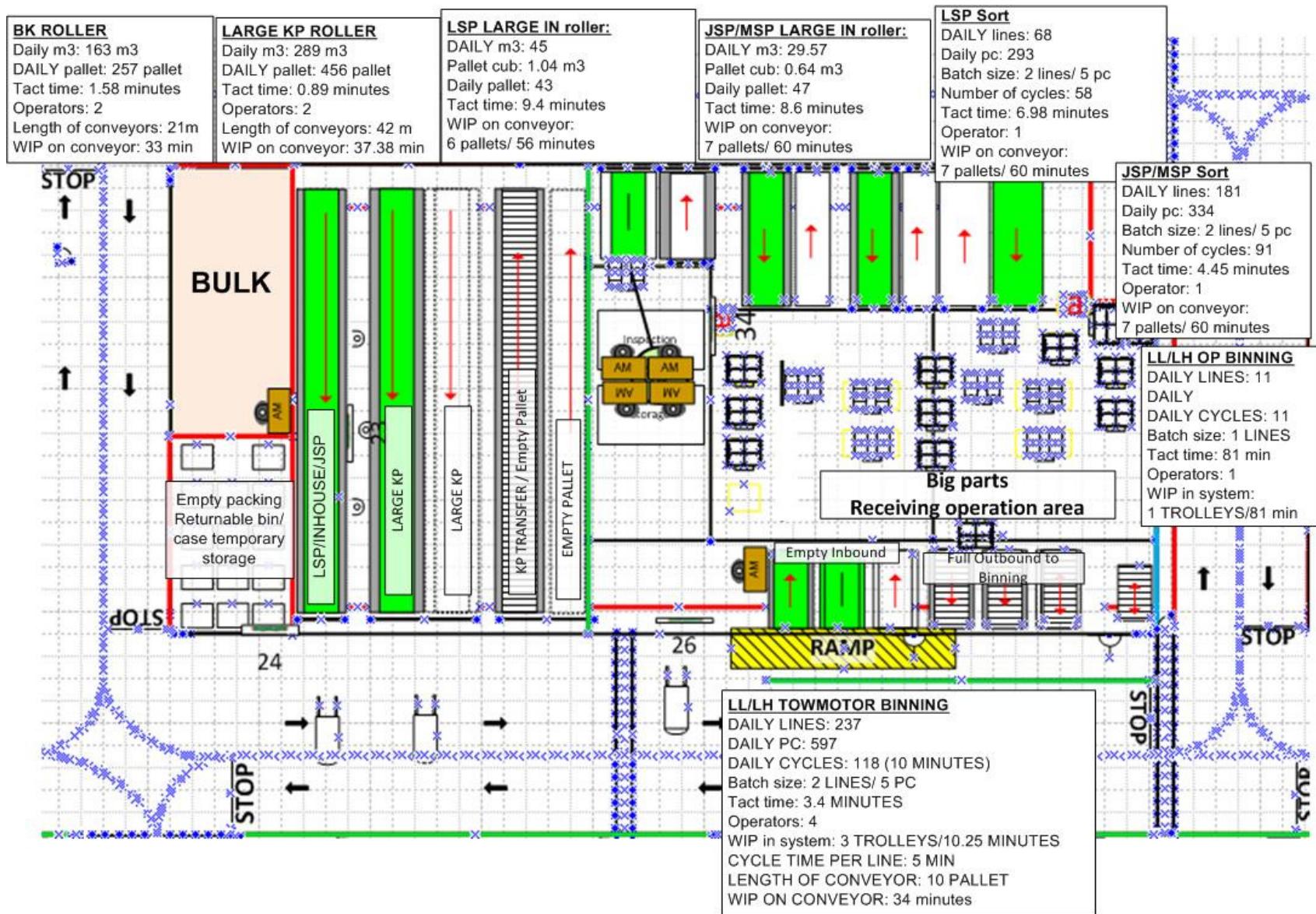

Figure 14: KPI of Big Parts Receiving Area.

Chapter 4: Areas for Improvement

On analysing the current warehouse operations, a few areas for improvement have been identified in the inbound system.

Receiving

- Receiving quantity is measured in the form of lines and pieces; there is a need to convert the measuring format to pallets or handling units to calculate the space configuration.
- The preliminary storage or staging area as well as the rollers are constantly full, indicating that there is a bottleneck in the system.
- Double handling on parts received mainly caused by parts incorrectly placed onto the rollers or the operator did not know the required allocation of the part.
- Parts that have to be relocated are packed in single form onto pallets causing unnecessary space usage and also contributing to the bottleneck.

Binning

- Insufficient space in the warehouse, especially for the bulk and large parts causing a delay at the receiving area.
- Binning sizes and quantity of parts are set according to the old warehouse standards and should be re-calculated to use the space of the new warehouse optimally.

Management

- Manpower is allocated according to an average workload and causes a variability of overtime work and idle time.
- There is a lack of standards where the manpower can be measured against.

4.1 Receiving

At the new parts distribution warehouse, Toyota receives thousands of parts daily from over 200 suppliers. To manage all these parts there needs to be a tight delivery schedule.

Currently the schedule is drawn up according to the number of lines and pieces. This method is not optimal because the ratio between the number of lines to the number of pieces varies from part to part. To create an accurate schedule, the number of handling units or pallets needs to be calculated.

Parts are constantly placed on the wrong rollers because the pallet may contain different types of parts or the box is sealed and the content in the box is unknown, these parts have to be diverted to their required allocation. This causes a lot of double handling and takes up unnecessary space on the rollers and contributes to the cause of the bottleneck.

There are parts that are packed in single formation onto pallets to be diverted or even sent to bulk storage. This causes a big amount of pallets that are left in the work in progress area. Singular parts should be grouped together onto one pallet and if the pallet is full it can be taken to its required location.

4.2 Binning

Currently the Work in Process (WIP) at the end of the day it is too high, this is currently caused by the insufficient space in the warehouse. This problem however is only for the bulk and large parts and causes the bottleneck at the receiving area.

The LE or binning quantity of the parts are set according to the old warehouse. To reduce the number of parts in the bulk storage area, the binning quantity of the primary bins must be reviewed to determine the maximum and optimal binning quantity of the parts.

If the quantity of the primary bins can be enlarged it will reduce the load in the bulk storage area so that there will be enough space for an even flow of parts into the warehouse. There is a section in the warehouse named the reserve area, which is still empty and reserved for new parts when a new model is launched. However this area could now be used to lift the pressure of the bulk storage area until the system is balanced. This solution would be to remove the bottleneck from the bulk storage area so that the targets can be met and the total WIP can be processed.

4.2.1.1 Simulating Large Parts Receiving Area

Simulation Results		
Number of parts Received	Number of parts Binned	Total WIP
540	475	65

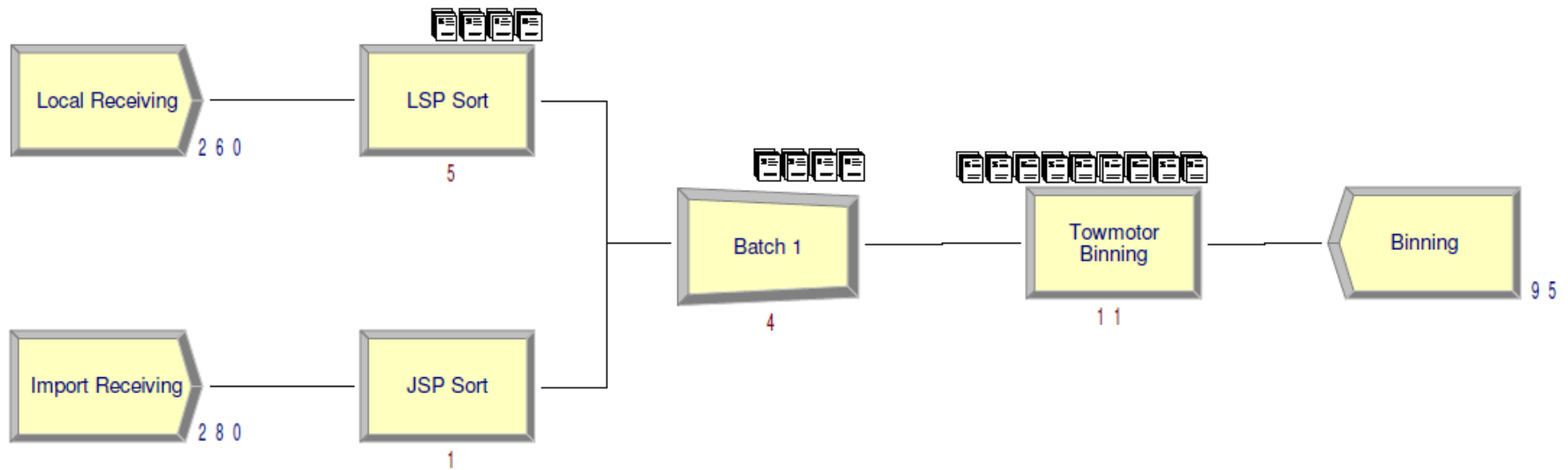
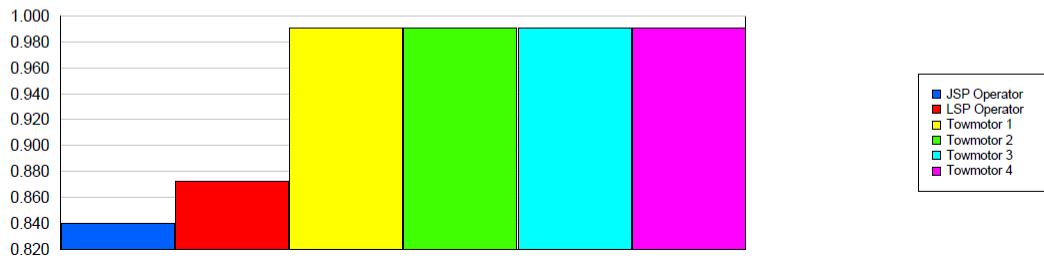
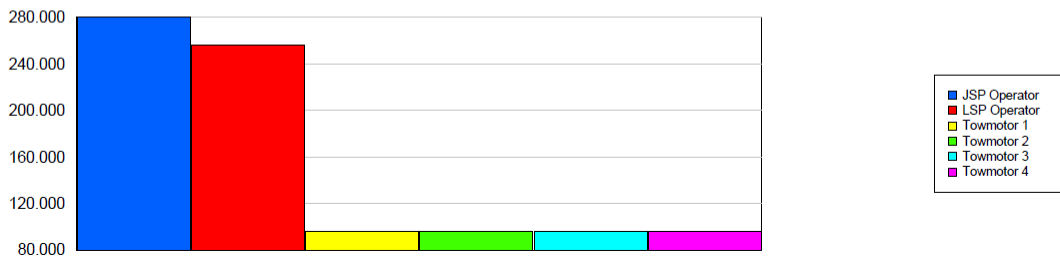

Figure 15: Simulation of Large Receiving Parts

Scheduled Utilization	Value
JSP Operator	0.8396
LSP Operator	0.8725
Towmotor 1	0.9910
Towmotor 2	0.9910
Towmotor 3	0.9910
Towmotor 4	0.9910



Total Number Seized	Value
JSP Operator	280.00
LSP Operator	256.00
Towmotor 1	96.0000
Towmotor 2	96.0000
Towmotor 3	96.0000
Towmotor 4	96.0000



This simulation shows that the process is stable, but there is still some WIP at the end of the day. The Tow motors are almost fully utilized which makes this area the bottleneck. However when there are more parts at the Import than Local, Import sorting will get congested and the local sorting will be idle. When proper planning is done the one operator can assist the other one when the workload is known, or even an operator from another station can assist if his workload is low.

4.2.1.2 Simulating Bulk Storage Receiving Area

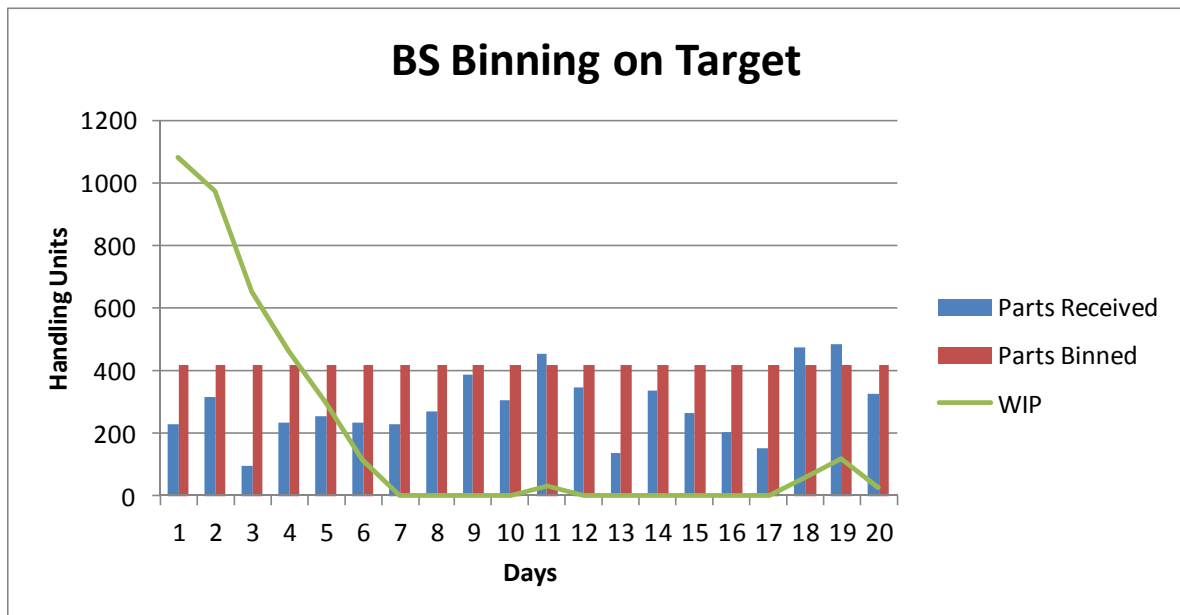
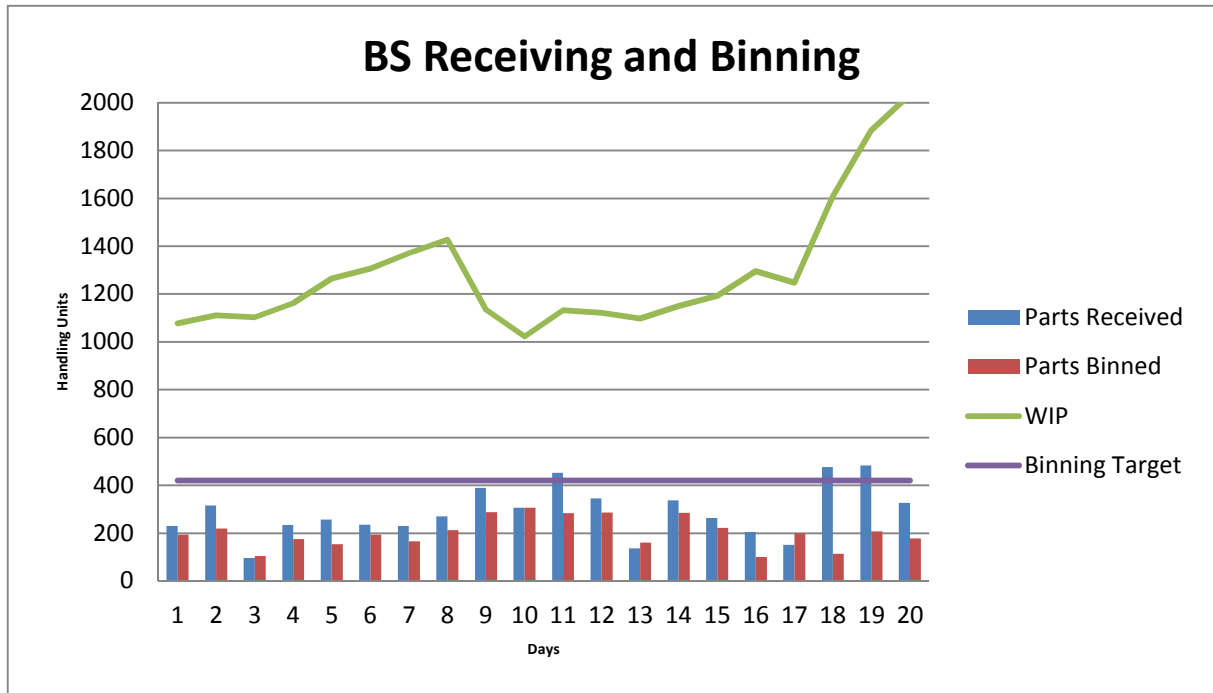

Figure 16: Current Binning vs. Binning on Target

The first figure above shows the current status of the inbound flow with an extreme amount of WIP in the system. The binning process is well below the target and this contributes to the high number of WIP. The second figure above shows how drastically the WIP can be eliminated when the binning process is on target, this also shows that the bottleneck is present at the binning process.

4.2.1 Management

The manpower is currently allocated according to the average workload per section. This method is not optimal because if for instance a bigger shipment of parts arrive in a few consecutive days, the number of parts above the average will not be processed and will thus create backlog and when the arrival rate is under average the manpower idle time will increase.

A solution to this problem would be to set up control boards, updating the workload schedule on a daily basis. The schedule should be managed on an hourly basis so that the processing speed can be managed and the amount of pallets processed can be monitored so that they don't fall behind on the schedule.

In order to make the schedule, the next day needs to be planned according to the proposed arrival schedule of the suppliers. The amount of lines, pieces and handling units should be determined and captured onto the control boards.

When the next day plan is updated, the number of lines, pieces and handling units are known and a manpower allocation schedule can be drawn up. Existing backlog can easily be planned into the schedule.

Because of the current schedule that is based on average number of parts, a need is created for overtime work for two Saturdays and three hours on five weekdays. Overtime is an unnecessary expense which could easily be avoided through an optimal schedule. The company can save over a million rand per month by eliminating overtime work.

Monthly Overtime			
Employers	Cost/hour	Overtime Hours	Total cost
600	R 84	30	R 1 512 000

Table 1: Monthly Overtime

Customer complaints are also running high at the moment with unresolved complaints dating back to up to 3 months. These complaints are mainly for undelivered orders; the problem is caused by the backlog and replenishment issues and can partly be solved through an optimal receiving and binning schedule.

LSP RECEIVING MANPOWER ASSIGNMENT BOARD														7		
PROCESS	PIC	AVAIL. M/H	WORK VOLUME				WORKRATE (min/item)	REQUIRED M/H	SHORTAGE /EXCESS	COUNTERMEASURE			REVIEW			
			PREVIOUS DAY	CARRY OVER	TODAY	TOTAL				OVERTIME	ADJUSTMENT	REMARKS	12:00		15:00	
													CUM ACTUAL	CUM TARGET	CUM ACTUAL	CUM TARGET
NORMAL TRUCK OFFLOADING																
NORMAL MODULE SORT																
SMALL GRV & SORT																
INTERRECEIVING OFFLOAD & SORT																
LSP RECEIVING TOTAL																
IMPORT DEVANNING																
IMPORT MODULE SORT																
BK/LK GRV																
LL GRV																
LARGE RECEIVING TOTAL																
PROCESS	HEADCOUNT					MANPOWER ALLOCATION	ABSENTEE REASON									
	TOTAL STAFF	FIXED STAFF	VARIABLE STAFF	ABSENCE	AVAIL. M/H		S/L	ST/L	C/L	AWL	A/L					
GROUP LEADER																
TEAMLEADER																
NORMAL TRUCK OFFLOADING																
NORMAL MODULE SORT																
SMALL GRV & SORT																
INTERRECEIVING OFFLOAD & SORT																
IMPORT DEVANNING							No	Name	Area	No	Name	Area				
IMPORT MODULE SORT							1			1						
BK/LK GRV							2			2						
LL GRV							3			3						

Figure 17: Manpower Assignment Board

This is a control board where the manpower is allocated to a certain area depending on the workload for that specific day and area. They must indicate at 12:00 and at 15:00 if they are on target so that manpower can be re-arranged or that overtime can be planned.

4.3 Proposed Ideal Supply chain with KAIZEN and JIT

In order to realize an ideal supply chain, seamless flow of parts and information according to JIT concept needs to be achieved. A small lot and high frequent logistics and short and stable supply lead time needs to be realized. The Just-In-Time concept is needed to procure and deliver the parts when they are needed in the exact amount required without increasing stock level. The JIT concept is realized by "Sell-One, Buy-One" operations and linking all processes seamlessly.

JIT concept can maintain high supply ability with an appropriate stock level. Below is an image of ideal service parts supply chain based on more sophisticated Just-In-Time concept with Delivery Due Date (DDD) assurance and short and stable flow. Short and stable flow is established by continuous KAIZEN to remove MUDA or stagnation of information and material in supply chain with increasing frequency and reducing lot size.

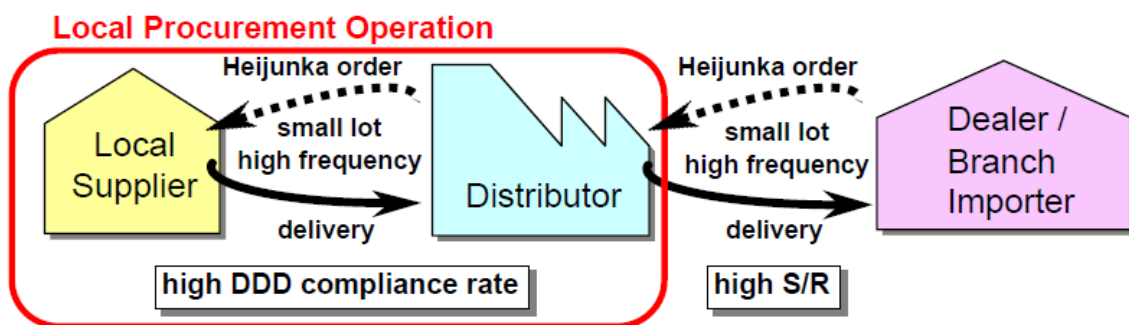

Figure 18: Local Procurement Operation

To realize Just-in-Time concept in local procurement, one must establish SHIKUMI that can achieve higher DDD compliance rate and accommodate daily order and daily delivery synchronizing with an actual order from a customer.

- a) Maintain high Delivery Due Date assurance

In order to ensure high supply ability to customers, it is important to keep high DDD compliance from suppliers. Without high DDD compliance, the distributor needs to keep high stock in case of delivery delay. DDD compliance rate is measured as one of the KPI to monitor delivery performance of suppliers.

- b) Increase the frequency of order cycle and delivery cycle

Our direction is a transition to Daily Order and Daily Delivery with minimum delivery unit to develop small lot and high frequency logistics scheme. Daily order enables to follow demand trend more flexibly. Daily delivery promotes smooth operation in the warehouse.

Consequently, frequent order and delivery enables to maintain high supply ability with minimum stock. Therefore, we need to drive for daily order expansion to establish fast and cyclic parts logistics flow.

c) Shorten procurement L/T

In order to develop short and stable logistics flow, procurement L/T needs to be reduced to drive for further customer satisfaction and stock reduction.

In order to achieve JIT parts logistics, parts should be supplied timely with shorter lead time by implementing small lot high frequent order and delivery. The best way to achieve high supply ability to end customer with keeping the minimum stock is to pursue JIT logistics throughout the supply chain. It is to connect every process of the chain with small lot high frequent order and delivery. To procure parts stably within standardized and shorter L/T is the basis of JIT logistics.

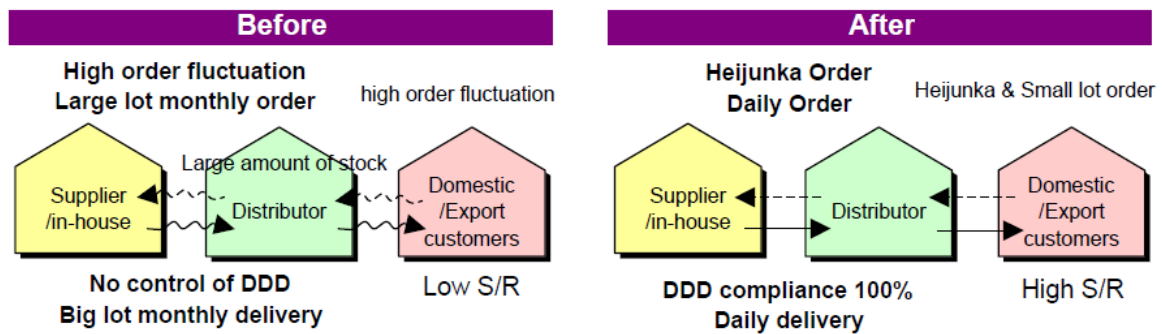

Figure 19: Before and after Heijunka

Based on this concept, the following 6 basic requirements are important to be set for Local Parts Procurement:

1. Stock / Non-stock Criteria

The stock and non-stock can be categorized according to the demand of the parts and its characteristics such as its space impact as well as the criticality of the parts availability. There is also a need to maintain a high service rate and to keep an appropriate stock level for JIT delivery.

2. Procurement Lead Time

The Procurement Lead Time is needed to determine the maximum inventory level that should be kept and to assign a delivery due date of each distribution order to a local supplier. The procurement lead time is also needed to supply lead time to customers for back order items.

3. Order Cycle and Delivery Cycle

The Order Cycle and the Delivery Cycle are very important to pace an order in a timely manner and to get the parts delivered in an appropriate cycle. The stock can also be reduced while maintaining a high supply ability.

4. Delivery Unit (Order Unit)

Delivery Unit means to buy only the necessary quantity of parts on the Sell One Buy One concept.

5. Order Allowance and Forecast Allowance.

Order Allowance and Forecast Allowance is used to keep the work load level order to the suppliers, meaning that the suppliers must not deliver the entire order on one day but rather consistent smaller amount on a daily basis. Appropriate action should be taken when fluctuations in the production order quantity occurs.

6. Delivery Due Date.

- For distributors
 - i. For inventory management: To minimize the stock level (Safety Stock for L/T) by stable delivery from suppliers.
 - ii. For warehouse manpower adjustment: To estimate the necessary manpower for the receiving process precisely and to adjust manpower in advance easily.
 - iii. For customers: To provide an accurate ETA based on DDD.
- For suppliers - To do better progress control from order taking until parts delivery according to DDD.

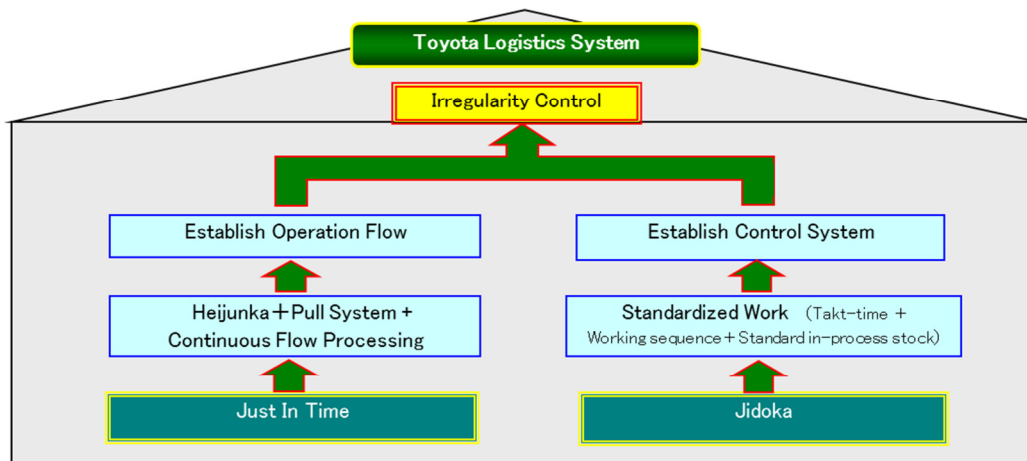

Figure 20: Toyota Logistics System

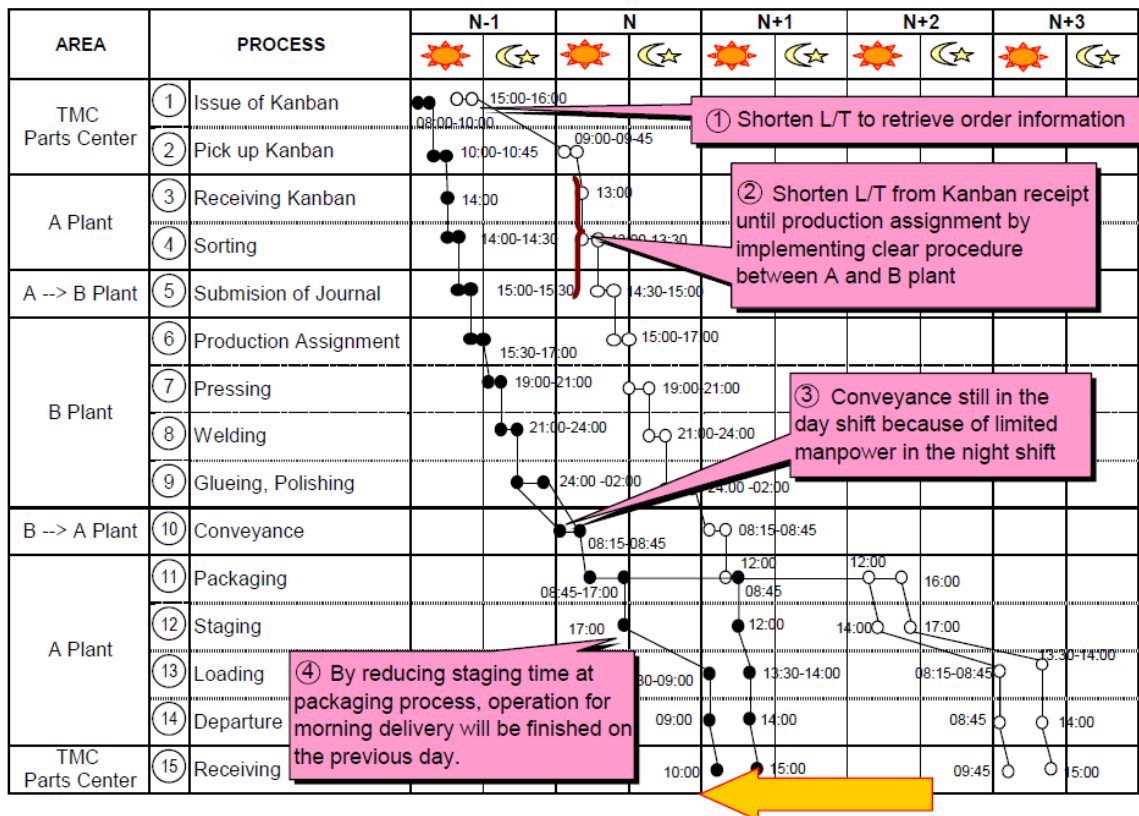

Figure 21: Lead Time before and after KAIZEN

The figure above clearly indicates how the lead time can be shortened through the implementation of KAIZEN. The continuous improvement process can be used to determine the root cause of inefficiencies and to expose waste to eliminate it.

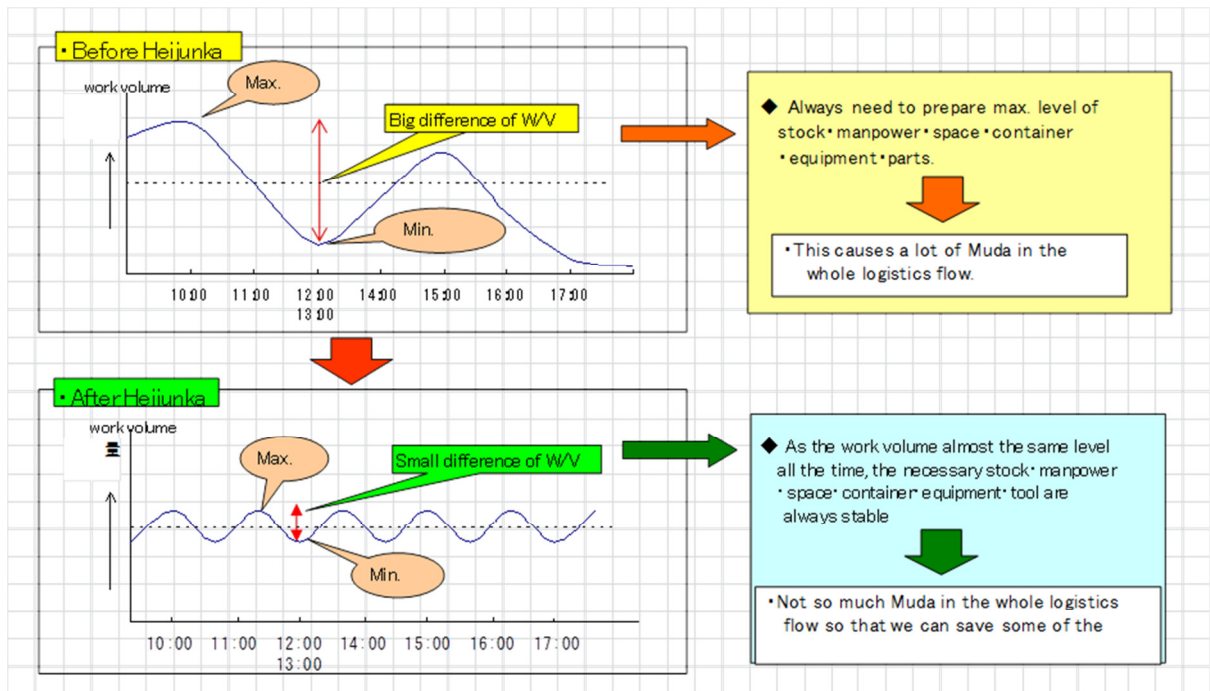

Figure 22: Work Load before and after Heijunka

The above figure indicates the difference before and after workload levelling. In the top graph the workload fluctuates with a big difference between the maximum and minimum workload, this causes overtime work as well as idle time. The bottom graph shows that there is a small difference in the workload when workload levelling has been implemented, this reduces overtime work as well as idle times.

5 Conclusion

With the suggested solutions and installation of control boards, day to day workload can be planned and manpower, machines and handling units can be aligned according to the schedule.

The bottlenecks can be eliminated from the binning process to reduce the work in process at the end of each day, eliminating the need for overtime work. Toyota can save approximately R1.5 million per month on overtime wages. Employees' productivity can be improved by eliminating overtime, this will give them more time to rest and injury and fatigue will decrease.

Through the Heijunka system waste can be eliminated, high delivery due dates can be maintained and Lead Times can be shortened through KAIZEN.

The JIT system is part of the Toyota way but it is not implemented yet in the whole system, all the issues and proposals in this document are striving towards the JIT method.

6 References

- Azadiver, F. 1986. Maximization of the throughput of a computerized automated warehousing system under system constraints. *Journal of production Research*, 24(3): 551-565.
- Burnett, D. 2001. Efficiently Modelling warehouse systems. *Journal of proceedings of the 2001 winter simulation conference*, 2(1): 1001-1006.
- Chase, R., Jacobs, F. & Aquilana, N. 2006. *Operations Management for Competitive Advantage*. McGraw-Hill/Irwin: New York.
- Ekren, B. & Heragu, S. 2010. Simulation-based regression analysis for the rack configuration of an autonomous vehicle storage and retrieval system. *Journal of Production Research*, 48(21): 6257-6274.
- Janicke, W. 2001. Excel Planning Interface for the SAP R/3 system. *Chemical Engineering & Technology*, 24(9): 903-908.
- Jenkins, C. 1990. *Complete guide to modern Warehouse Management*. Prentice Hall: Englewood Cliffs.
- Johnson, A. & McGinnis, L. 2010. Performance measurement in the warehousing industry. *Journal of IIE Transactions*, 43(3): 220-230.
- Langley, J. *et al.* 2008. *Managing Supply Chains*. South-Western Cengage Learning: Canada.
- Nishi, T. & Konishi, M. 2010. An optimisation model and its effective beam search heuristics for floor-storage warehousing systems. *Journal of Production Research*, 48(7): 1947-1966.
- Pillai, M. 2010. Commodity Futures Markets, Warehouse Receipts, and Dynamics of Warehousing Infrastructure: The Indian Scenario. *Journal of Infrastructure*, 8(4): 38-49.
- Realtime Dashboard*. [Online]. Available: <http://www.proteussafture.com> [Accessed 7 May 2012].

Tompkins, J. *et al.* 2010. *Facilities Planning*. Hamilton Printing Co.: USA

Wang, Q., McIntosh, R. & Brian. 2010. A new generation automated warehousing capability. *Journal of Computer Integrated Manufacturing*, 23(6): 565-573.

Yugang, Y. & Rene, B. 2012. Sequencing heuristics for storing and retrieving unit loads in 3D compact automated warehousing systems. *Journal of Design & Manufacturing*, 44(2): 69-87.