

REPÚBLICA FEDERATIVA DO BRASIL

MINISTÉRIO DOS TRANSPORTES

United Nations Development Programme (UNDP)

# Research on the Interrelationships Between Costs of Highway Construction, Maintenance and Utilization

Final Report - 1981

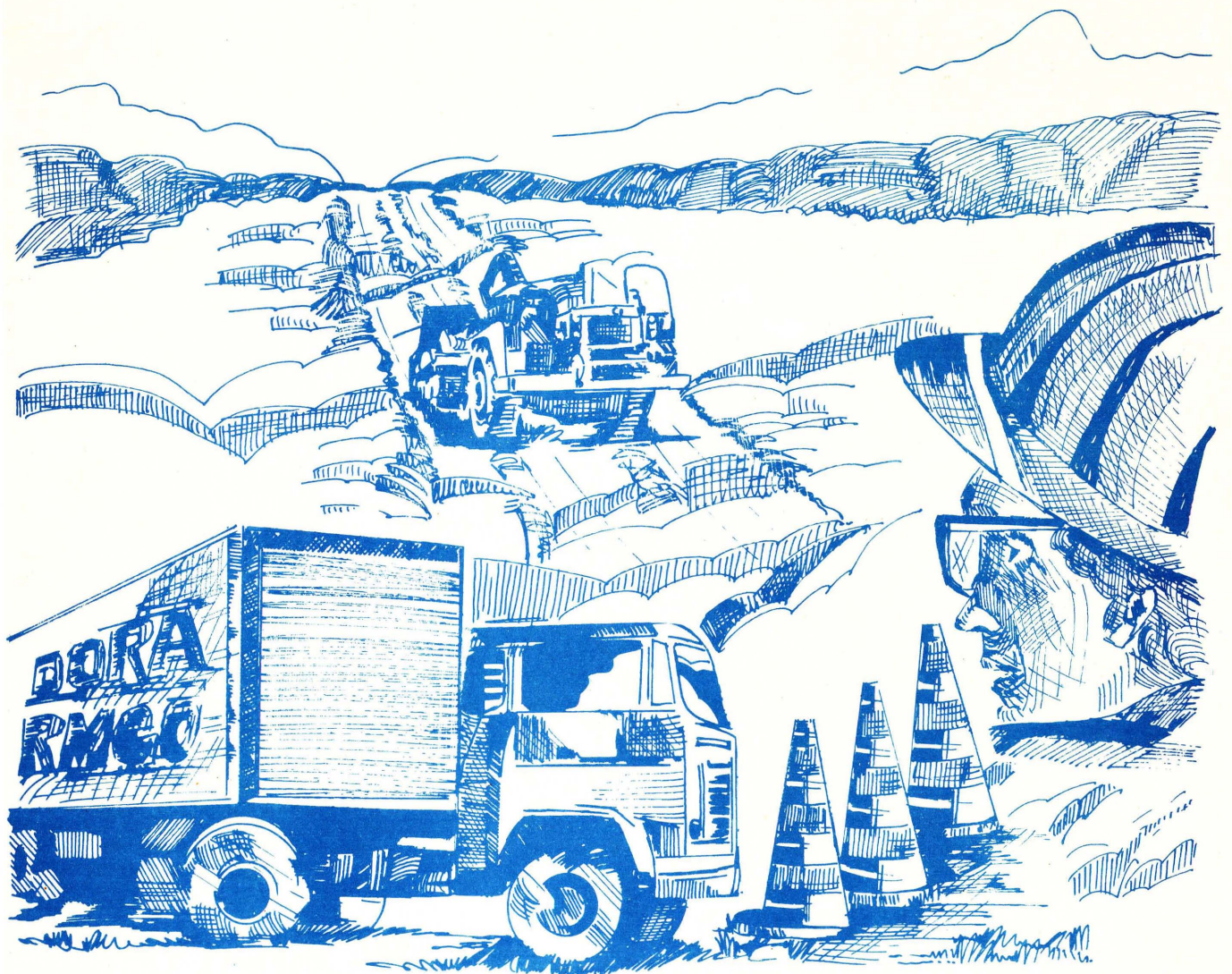

VOLUME 3 – INSTRUMENTATION

REPÚBLICA FEDERATIVA DO BRASIL

MINISTÉRIO DOS TRANSPORTES

United Nations Development Programme (UNDP)

**Research on the Interrelationships  
Between Costs of Highway  
Construction, Maintenance  
and Utilization**

**Final Report - 1981**

**SPONSORED BY:**

**MINISTÉRIO DOS TRANSPORTES**

**SECRETARIA DE PLANEJAMENTO DA PRESIDÊNCIA DA REPÚBLICA**

**Instituto de Planejamento Econômico e Social - IPEA**

**Secretaria de Cooperação Econômica e Técnica Internacional - SUBIN**

**UNITED NATIONS DEVELOPMENT PROGRAMME (UNDP)**

**PREPARED BY:**

**MINISTÉRIO DOS TRANSPORTES**

**Empresa Brasileira de Planejamento de Transportes - GEIPOT**

**Departamento Nacional de Estradas de Rodagem - DNER**

**UNITED NATIONS DEVELOPMENT PROGRAMME (UNDP)**

**International Bank for Reconstruction and Development (IBRD)**

**Texas Research and Development Foundation - TRDF**

**WITH THE PARTICIPATION OF:**

**Departamento de Estradas de Rodagem de Goiás - DER/GO**

**Departamento de Estradas de Rodagem de Minas Gerais - DER/MG**

EMPRESA BRASILEIRA DE PLANEJAMENTO DE TRANSPORTES - GEIPOT. Research on the interrelationships between costs of highway construction, maintenance and utilization; final report - 1981. Brasília, 1982. 12v. il.

388.10981

E55p

Conteúdo: v.1 Summary of the ICR Research v.2 Methods and organization v.3 Instrumentation v.4 Statistical guide v.5 Study of road user costs v.6 Study of vehicle behavior and performance v.7 Study of pavement maintenance and deterioration v.8 Highway cost model (MICR) v.9 Model of time and fuel consumption (MTC) v.10 Model for simulating traffic (MST) v.11 Fundamental equations v.12 Index to PICR documents.

1. Rodovias - custos - Brasil 2. Rodovias conservação - Brasil  
3. Rodovias - utilização - Brasil - I. Título.

## PREFACE

This research project was funded through an agreement signed in January, 1975 by the Brazilian Government and the United Nations Development Programme (UNDP). The Ministry of Transportation, acting through the Brazilian Transportation Planning Agency (GEIPOT), assumed the responsibility for the project on behalf of the Brazilian Government, and the International Bank for Reconstruction and Development (IBRD) acted as the executing agency for UNDP.

The research was carried out by GEIPOT and the National Highway Department (DNER), acting through its Road Research Institute (IPR). Funding from the Brazilian Government was channeled through the Institute for Economic and Social Planning (IPEA) and the Secretariat for International Economic and Technical Cooperation (SUBIN), along with the Ministry of Transportation.

The World Bank contracted the Texas Research and Development Foundation (TRDF) to organize the international technical staff and to select and purchase the imported equipment needed for the research. The participation of the TRDF continued until December of 1979.

This report is comprised of twelve volumes (each edited in both English and Portuguese) which summarize the concepts, methods and results obtained by December, 1981 by the project entitled "Research on the Interrelationships Between Costs of Highway Construction, Maintenance and Utilization (PICR)". It includes a documentary index volume which will aid researchers in locating topics discussed in this report and in numerous other documents of the PICR. This report contains much detailed analysis which is being presented for the first time, and also incorporates relevant parts of earlier reports and documents produced under the 1975 Agreement, updating them through the inclusion of new results and findings.

A special mention is due the Highway Departments of the States of Minas Gerais and Goiás, the Universities of Aston, Birmingham, Juiz de Fora, Minas Gerais and Texas, and the Western Australia Main Roads Department, which placed some of their best and most experienced personnel at the service of this project to fill many key positions on the research staff.

Finally, thanks are due the Transport and Road Research Laboratory for its assistance during the initial stages of the project, along with specialists from various countries who periodically visited Brazil to discuss the work being done in the PICR and to assist the permanent research staff in conducting analyses.

JOSÉ MENEZES SENNA  
President

VOLUMES IN THIS REPORT\*

- VOLUME 1 - SUMMARY OF THE ICR RESEARCH
- VOLUME 2 - METHODS AND ORGANIZATION
- VOLUME 3 - INSTRUMENTATION
- VOLUME 4 - STATISTICAL GUIDE
- VOLUME 5 - STUDY OF ROAD USER COSTS
- VOLUME 6 - STUDY OF VEHICLE BEHAVIOR AND PERFORMANCE
- VOLUME 7 - STUDY OF PAVEMENT MAINTENANCE AND DETERIORATION
- VOLUME 8 - HIGHWAY COSTS MODEL (MICR)
- VOLUME 9 - MODEL OF TIME AND FUEL CONSUMPTION (MTC)
- VOLUME 10- MODEL FOR SIMULATING TRAFFIC (MST)
- VOLUME 11- FUNDAMENTAL EQUATIONS
- VOLUME 12- INDEX TO PICR DOCUMENTS

---

\* Volume 1 contains a brief description of the contents of each volume, while Volume 12 provides a subject index to this report and all other PICR documents, including technical memoranda and working documents.



## CONTENTS OF THIS VOLUME

PREFACE	iii
VOLUMES IN THIS REPORT	v
LIST OF FIGURES	xi
LIST OF TABLES	xv
SUMMARY	xvii
CHAPTER 1 - INTRODUCTION.....	1
CHAPTER 2 - ROAD SURFACE ROUGHNESS MEASUREMENT SYSTEMS.....	5
2.1 - INTRODUCTION.....	7
2.2 - MAYSMETER.....	8
2.2.1 - Operating Principle.....	16
2.2.2 - Field Operation.....	16
2.2.3 - Maintenance.....	19
2.2.4 - Recommended Maintenance Facilities.....	21
2.2.5 - Major Sources of Maintenance Problems.....	21
2.3 - PROFILOMETER.....	22
2.3.1 - Introduction.....	22
2.3.2 - Operating Principle.....	24
2.3.3 - Field Operation.....	24
2.3.4 - Maintenance.....	30
2.3.5 - Recommended Maintenance Facilities.....	31
CHAPTER 3 - THE SURVEY VEHICLE.....	33
3.1 - INTRODUCTION.....	35
3.2 - GRADE METER.....	35
3.3 - HORIZONTAL CURVATURE METER.....	40
3.4 - DISTANCE METER.....	43
3.5 - ROUGHNESS METER.....	46
3.6 - FIELD OPERATION.....	46
3.7 - OPERATING PROCEDURES.....	46
3.8 - MAINTENANCE.....	47
3.9 - RECOMMENDED REPAIR FACILITIES.....	47
CHAPTER 4 - TRAFFIC BEHAVIOR MEASURING EQUIPMENT.....	49
4.1 - INTRODUCTION.....	51
4.2 - RADAR.....	51



4.2.1 - Field Operation.....	51
4.2.2 - Maintenance.....	57
4.2.3 - Recommended Maintenance Facilities.....	60
4.3 - CAMERA BOX AND RECORDER BOX.....	60
4.3.1 - Camera Box.....	60
4.3.2 - Recorder Box.....	63
4.3.3 - Field Operation.....	63
4.3.4 - Maintenance.....	65
4.4 - TACHOGRAPH.....	65
4.4.1 - Field Operation.....	65
4.4.2 - Maintenance.....	69
4.4.3 - Maintenance Facilities.....	69
4.5 - THE PHOTO-ELECTRIC LIGHT INTENSITY DETECTOR (PELID).....	69
4.5.1 - Operating Principle.....	72
4.5.2 - Field Operation.....	72
4.5.3 - Maintenance.....	73
4.6 - TRAFFIC FLOW DATA LOGGER.....	73
4.6.1 - Operating Principle.....	74
4.6.2 - Field Operation.....	74
4.6.3 - Maintenance.....	75
4.6.4 - Recommended Maintenance Facilities.....	75
CHAPTER 5 - PAVEMENT DEFLECTION EQUIPMENT.....	77
5.1 - INTRODUCTION.....	79
5.2 - BENKELMAN BEAM.....	79
5.2.1 - Maintenance.....	79
5.3 - DYNAFLECT.....	82
5.3.1 - Operating Principle.....	82
5.3.2 - Field Operation.....	82
5.3.3 - Recommended Maintenance Facilities.....	86
5.3.4 - Major Sources of Maintenance Problems.....	86
CHAPTER 6 - FUEL CONSUMPTION MEASUREMENT EQUIPMENT.....	89
6.1 - INTRODUCTION.....	91
6.2 - RESERVOIR FUEL METER.....	91
6.2.1 - Accuracy of the Measurements.....	97
6.2.2 - Field Operation.....	97
6.2.3 - Recommended Maintenance Facilities (Fuel Meters Only).....	100

6.3 - THE VOLUMETRIC FUEL METERS.....	100
6.3.1 - Field Operation.....	101
6.3.2 - Accuracy.....	101
6.3.3 - Sources of Problems.....	104
CHAPTER 7 - TRAFFIC COUNTERS.....	105
7.1 - INTRODUCTION.....	107
7.2 - LEOPOLD AND STEVENS COUNTER.....	109
7.2.1 - Installation and Operation.....	109
7.2.2 - Maintenance.....	109
7.2.3 - Recommended Repair Facilities.....	111
7.3 - FISCHER AND PORTER COUNTER.....	111
7.3.1 - Maintenance.....	111
7.3.2 - Recommended Repair Facilities.....	113
7.4 - STREETER AMET COUNTER.....	113
7.4.1 - Maintenance.....	113
7.4.2 - Recommended Repair Facilities.....	115
7.5 - MANUAL COUNTERS.....	115
CHAPTER 8 - VEHICLE WEIGHT MEASUREMENTS.....	119
8.1 - INTRODUCTION.....	121
8.2 - THE PORTABLE WHEEL-LOAD WEIGHER.....	121
8.2.1 - Description.....	121
8.2.2 - Field Operation.....	121
8.2.3 - Maintenance.....	122
8.3 - THE WEIGH-IN-MOTION SYSTEM (WIM).....	122
8.3.1 - Sensors.....	129
8.3.2 - The Signal Conditioning Unit.....	129
8.3.3 - The Computer.....	134
8.3.4 - The Video Unit (CRT).....	134
8.3.5 - The Keyboard.....	134
8.3.6 - The Magnetic Tape Unit.....	134
8.3.7 - The Printer.....	134
8.3.8 - The Paper Tape Reader.....	135
8.3.9 - Field Operation.....	135
8.3.10 - Maintenance.....	139
8.3.11 - Recommended Maintenance Facilities.....	139

CHAPTER 9 - DATA CONVERSION EQUIPMENT.....	141
9.1 - INTRODUCTION.....	143
9.2 - EQUIPMENT DESCRIPTION.....	143
9.3 - FIELD OPERATION.....	146
9.4 - MAINTENANCE.....	146
9.5 - RECOMMENDED REPAIR FACILITIES.....	147
CHAPTER 10 - MEASUREMENT OF ROAD SURFACE CONDITIONS.....	149
10.1 - INTRODUCTION.....	151
10.2 - RUT DEPTH GAUGE.....	151
10.3 - LOOSE MATERIAL SAMPLING DEVICE.....	151
10.4 - SKID RESISTANCE TESTER.....	156
10.5 - TEXT-UR-METER.....	156
CHAPTER 11 - METEOROLOGICAL MEASUREMENTS.....	163
11.1 - INTRODUCTION.....	165
11.2 - RAIN GAUGE.....	165
11.2.1 - Maintenance.....	169
11.2.2 - Recommended Maintenance Facilities.....	169
11.3 - WIND METER.....	169
CHAPTER 12 - CONCLUSIONS AND RECOMMENDATIONS.....	173
REFERENCES CITED.....	177

## LIST OF FIGURES

FIGURE 2.1 - MAYSMEETER INSTALLED IN A CAR.....	9
FIGURE 2.2 - GRAPHICAL RECORDER AND MECHANICAL ODOMETER.....	10
FIGURE 2.3 - GRAPHICAL MODEL CHART RECORDING.....	11
FIGURE 2.4 - MAYSMEETER BLOCK DIAGRAM.....	12
FIGURE 2.5 - TRANSMITTER.....	13
FIGURE 2.6 - MAYSMEETER TRANSMITTER INSTALLED.....	14
FIGURE 2.7 - DIGITAL ODOMETER (DMI) AND SUMMATION UNIT.....	17
FIGURE 2.8 - INSTALLATION OF MAGNETS ON TIRE RIM.....	18
FIGURE 2.9 - PROFILOMETER IN OPERATION ON A TEST SECTION.....	23
FIGURE 2.10- PROFILOMETER BLOCK DIAGRAM.....	25
FIGURE 2.11- PROFILOMETER.....	26
FIGURE 2.12- PROFILOMETER PROCESSING AND RECORDING INSTRUMENTS.....	27
FIGURE 3.1 - SURVEY VEHICLE.....	36
FIGURE 3.2 - SURVEY VEHICLE PANEL SHOWING DMI, MAYSMEETER, GYRO- COMPASS AND GRADE METER DISPLAY.....	37
FIGURE 3.3 - ACCELEROMETER USED TO DETECT GRADE.....	39
FIGURE 3.4 - BLOCK DIAGRAM - GRADE METER AND GYROCOMPASS IN THE SURVEY VEHICLE.....	41
FIGURE 3.5 - GRADE METER DISPLAY.....	42
FIGURE 3.6 - GYROCOMPASS DISPLAY.....	44
FIGURE 3.7 - DIGITAL ODOMETER (DMI).....	45
FIGURE 4.1 - RADAR PANEL.....	52
FIGURE 4.2 - RADAR ANTENNA.....	53
FIGURE 4.3 - RADAR POWER SOURCE.....	54
FIGURE 4.4 - MIRROR BOX.....	55
FIGURE 4.5 - MIRROR BOX AT RADAR TEST SITE.....	56
FIGURE 4.6 - RADAR PANEL.....	56
FIGURE 4.7 - RADAR UNIT AT TEST SITE.....	58

FIGURE 4.8	- CAMERA BOX BLOCK DIAGRAM.....	61
FIGURE 4.9	- CAMERA BOX ( 8 mm).....	62
FIGURE 4.10	- CAMERA BOX (16mm).....	62
FIGURE 4.11	- RECORDER BOX DATA ROUTE DIAGRAM.....	64
FIGURE 4.12	- ARGO TACHOGRAPH.....	66
FIGURE 4.13	- SANGAMO TACHOGRAPH.....	67
FIGURE 4.14	- SANGAMO TACHOGRAPH CHART.....	68
FIGURE 4.15	- PELID MOUNTED ON A TRIPOD.....	70
FIGURE 4.16	- PELID IN THE FIELD.....	71
FIGURE 4.17	- FIELD LAYOUT.....	76
FIGURE 5.1	- BENKELMAN BEAM.....	80
FIGURE 5.2	- BENKELMAN BEAM BEING USED TO MEASURE PAVEMENT DEFLECTIONS.....	81
FIGURE 5.3	- DYNAFLECT IN MEASUREMENT POSITION ON A TEST SECTION.....	83
FIGURE 5.4	- DYNAFLECT SENSORS IN POSITION AND READY FOR TESTING.....	83
FIGURE 5.5	- DYNAFLECT CONTROL UNIT.....	85
FIGURE 6.1	- SYSTEM SCHEMATIC.....	94
FIGURE 6.2	- DIESEL SYSTEM PANEL LAYOUT.....	95
FIGURE 6.3	- RESERVOIR FUEL METER INSTALLED IN A VEHICLE.....	96
FIGURE 6.4	- MECHANICAL STOPWATCHES.....	98
FIGURE 6.5	- GASOLINE SYSTEM PANEL.....	99
FIGURE 6.6	- COLUMBIA SYSTEM.....	102
FIGURE 6.7	- COLUMBIA INSTALLATION DIAGRAM.....	103
FIGURE 7.1	- THREE TYPES OF TRAFFIC COUNTERS USED IN THE STUDY.....	108
FIGURE 7.2	- LEOPOLD & STEVENS TRAFFIC COUNTER.....	110
FIGURE 7.3	- FISCHER & PORTER COUNTER 3000.....	112
FIGURE 7.4	- STREETER AMET TRAFFIC COUNTER.....	114
FIGURE 7.5	- MULTIPLE TALLY.....	116
FIGURE 7.6	- TALLY REGISTER.....	117

FIGURE 8.1	- PORTABLE WEIGHER GENERAL VIEW.....	123
FIGURE 8.2	- PORTABLE WHEEL-LOAD WEIGHER DATA ROUTE DIAGRAM.....	124
FIGURE 8.3	- TRUCK PASSING OVER WIM SITE.....	126
FIGURE 8.4	- WEIGH-IN-MOTION DATA ROUTE DIAGRAM.....	127
FIGURE 8.5	- SIMPLIFIED BLOCK DIAGRAM FOR WIM SYSTEM.....	128
FIGURE 8.6	- LOAD CELLS BRIDGE ARRANGEMENT.....	130
FIGURE 8.7	- TRANSDUCER INSTALLATION LAYOUT.....	131
FIGURE 8.8	- TECHNICIANS LEVELLING TRANSDUCER SUPPORT STRUCTURE.....	132
FIGURE 8.9	- INSTALLATION OF TRANSDUCER SUPPORT STRUCTURE.....	132
FIGURE 8.10	- TECHNICIAN ADJUSTING LOAD TRANSDUCER POSITION.....	133
FIGURE 8.11	- LOAD TRANSDUCERS READY TO BE COVERED WITH PRESSURE PLATES.....	133
FIGURE 8.12	- TRAILER LAYOUT.....	136
FIGURE 8.13	- COMPUTER RACK.....	137
FIGURE 8.14	- PERIPHERAL EQUIPMENT.....	138
FIGURE 9.1	- DATA CONVERSION EQUIPMENT.....	144
FIGURE 9.2	- A/D CONVERTER.....	145
FIGURE 10.1	- RUT DEPTH GAUGE.....	152
FIGURE 10.2	- RUT DEPTH GAUGE IN OPERATION.....	153
FIGURE 10.3	- LOOSE MATERIAL SAMPLER.....	154
FIGURE 10.4	- TECHNICIANS MEASURING RUT DEPTH AND GRAVEL LOOSENESS ON AN UNPAVED ROAD.....	155
FIGURE 10.5	- SKID-RESISTANCE TESTER.....	157
FIGURE 10.6	- INDICATOR OF SKID TESTER.....	158
FIGURE 10.7	- TEXT-UR-METER.....	159
FIGURE 10.8	- TEXT-UR-METER IN USE.....	160
FIGURE 11.1	- PLASTIC POT RAIN GAUGE.....	166
FIGURE 11.2	- AUTOMATIC ELECTRONIC RAIN GAUGE.....	167
FIGURE 11.3	- RAIN GAUGE OUTPUT.....	168
FIGURE 11.4	- WIND SPEED INDICATOR.....	170
FIGURE 11.5	- WIND METER IN USE.....	171



LIST OF TABLES

TABLE 2.1 - SPECIFICATIONS FOR THE MAYSMETER SYSTEM.....	15
TABLE 2.2 - MAYSMETER ROUGHNESS DATA RECORDING FORM.....	20
TABLE 2.3 - SPECIFICATIONS FOR THE PROFILOMETER.....	28
TABLE 3.1 - SPECIFICATIONS FOR THE SURVEY VEHICLES.....	38
TABLE 3.2 - HIGHWAY SURVEY FIELD RECORD FORM.....	48
TABLE 4.1 - RADAR DATA RECORDING FORM.....	59
TABLE 5.1 - SPECIFICATIONS FOR THE DYNAFLECT.....	84
TABLE 6.1 - FUEL CONSUMPTION DATA RECORDING FORM.....	92
TABLE 8.1 - PORTABLE SCALE FIELD DATA RECORDING FORM.....	125





## SUMMARY

The Research on the Interrelationships Between Costs of Highway Construction, Maintenance and Utilization (PICR) was carried out in Brazil with the objective of providing a fundamentally new data base for the economic cost/benefit evaluation of alternative standards of highway construction and maintenance. To form this data base, measuring instruments with a total cost of more than US\$750,000 were utilized. The most important of these instruments were manufactured in the U.S.A. specifically for this Research and, therefore, cannot be considered as either completely developed or tested. A major share of the work of the Instrumentation Group of the PICR consisted of developing these instruments and adapting them to the operational conditions found in Brazil. Due to the dimensions and innovative aspects of the Research, it was necessary to design and build highly original apparatuses *in loco*.

This Volume presents a brief description of the instruments used in the PICR, explains what they measure, the reason why they were chosen or built, their precision, how they were employed and their trustworthiness. The text also contains bibliographic references, providing the reader with access to the technical and operational details of the equipment described. Manufacturers are also indicated.

Taking into account both the technical problems which arose, as well as the significance and utility of the data produced, an evaluation of the performance of each instrument is also presented.

The conclusion in the final Chapter is that, in projects of limited duration, such as the PICR, one should avoid the use of instruments which have not been fully tested. Should this prove impossible, it is recommended that sufficient time be dedicated to the development and refinement of the instruments in the environment in which they will be utilized, before initiating actual data gathering.



CHAPTER 1  
INTRODUCTION

The Research on the Interrelationships Between Costs of Highway Construction, Maintenance and Utilization (PICR) was conducted in Brazil to provide a fundamentally new data base for estimating the economic benefits and costs of alternative highway design and maintenance standards. The measurements made to create this data base required the use of over US\$750,000 of equipment. Because of the dimensions and the innovative aspects of the Research many of these instruments had to be modified and/or modernized *in loco*. Other instruments were quite original and were designed and constructed specially to suit new needs.

The purpose of this Volume is to give the reader a brief description of the instruments used in the project, including explanations regarding what they measure, why they were selected, their accuracy, how they were used, and their reliability. The reader will also be referred to more detailed information concerning technical aspects of the equipment and to reports explaining how the various devices were used to collect data in the field by the research team.

At the outset of the project few instrumentation facilities existed. GEIPOT provided a large parking garage which was modified to provide shops and laboratories with work benches and storage cabinets. The workshop is described in a Project Instrumentation Memo (Buller, "Workshops"). As project equipment was gathered and delivered to the Texas Research and Development Foundation (TRDF), it was checked out and forwarded to Brazil by the international staff instrumentation engineer. By March of 1976, the bulk of equipment had been purchased and shipped, and the international staff instrumentation engineer joined his counterpart in Brasilia. Subsequent equipment and spare parts were handled by TRDF's Texas staff.

All of the test and measurement equipment required for the project was purchased in the United States. Other difficult-to-obtain or expensive items needed for the project were also purchased and shipped to Brazil. During October, 1975, the core of the Instrumentation Group was hired and its training initiated. The Instrumentation Group was one of the smaller study groups in terms of manpower, with three electronics engineers, one electronics technician, two electrical technicians, a carpenter and a mechanic.

Many of the measurement devices were designed and built by the Instrumentation Group to meet particular project needs when no such devices were commercially available. Such cases are identified in the

ensuing chapters, and detailed fabrication information is presented in the referenced working documents.

The location of the project headquarters in Brasília caused the Instrumentation Group some inconvenience, since Brasília is not an industrial city and therefore has virtually no demand for the type of materials and spare parts that such a team required. The purchase of these items in Rio de Janeiro or São Paulo proved infeasible because of administrative problems. Consequently, many items were imported through the auspices of the United Nations Development Programme, in cooperation with the Brazilian Government.

The rural roads on which the instruments were required to operate were decidedly detrimental and caused severe damage. Vehicles travelling over unpaved roads received onslaughts of dust in the dry season and mud in the wet season. At times, temperatures in full sunlight exceeded 40°C. The research teams required data from the roughest road surfaces available, exposing the instruments to considerable abuse.

The project was divided into three main research groups which hired and administered their own data gathering force. Since there is normally little demand for such technicians and operators in Brasília, it was difficult to locate qualified people for these positions. The volume and variety of data collected made it impossible for a senior researcher to always be present during data collection. This caused some unnecessary abuse to equipment, and on occasion resulted in incorrect data, requiring data collection efforts to be repeated.

Despite such difficulties, a trained and experienced Brazilian staff was formed to undertake the project and which is prepared for future work. Most of the project equipment survived the hard use and was adapted as necessary to serve in the test environment. The equipment assembled during this project was reconditioned and stored in Brasília in October, 1979, to serve in future research.

A description of the project instrumentation follows. This Volume is organized as much as possible into types of measurements, such as those of road roughness, fuel consumption, and vertical and horizontal geometry.

CHAPTER 2  
ROAD SURFACE ROUGHNESS  
MEASUREMENT SYSTEMS





## 2.1 INTRODUCTION

The road roughness measuring device used in the PICR was the Mays-Ride-Meter manufactured by the Rainhart Company<sup>1</sup>. This instrument was modified by the Instrumentation Group with the replacement of both the graphical recording output unit and the mechanical odometer, the resulting unit being designated Maysmeter. This device measures the accumulated motion of the vehicle chassis relative to its rear axle, as the vehicle moves along a road surface. The number read by the instrument (in inches) divided by the distance travelled by the vehicle (in miles) is the inches/mile index for that road. This index was accepted as representative of the level of roughness present on the road.

The main advantages of the Maysmeter, like other response-type systems, are its relatively low cost, simplicity of operation, and high measuring speed. However, the measurements are influenced by the characteristics of the host-vehicle, by the type of pavement, and by environmental factors (Gillespie *et al.*). Stability over time, calibration and correlation with other similar and dissimilar systems are problems. It is thus essential to establish a method for correlating each Maysmeter's output with a road roughness standard. The General Motor's Road Surface Dynamics Profilometer was acquired to perform that function in the PICR and was employed to establish and to monitor the Maysmeter control sections used in the necessary calibration, all according to a methodology developed by members of the Research team (GEIPOT/PICR, Working Documents 5, 6, 7 and 10).

Recently Alckmin *et al.* questioned the validity of the roughness data collected with the Maysmeter for certain applications. Their work shows that the intrinsic limitations of the instrument (e.g. hysteresis and quantization), together with its acute and uncontrollable sensitivity to environmental and operational factors, as well as to the state of the host-vehicle, renders it unable to attain the minimum accuracy level required by some of the studies and experiments on the PICR. It also points out that the uses of the Maysmeter in the PICR are much more demanding than its applications in the U.S.A., where the instrument is virtually never used on unpaved roads.

---

<sup>1</sup> The addresses for the manufacturers mentioned in the text appear in the reference section at the end of this work, in alphabetical order.

## 2.2 MAYS METER

The Maysmeter is a road surface roughness recorder that is installed in a standard vehicle as shown in Figure 2.1. It was selected for use because of high data production capabilities, low cost, and demonstrated field reliability, based on its wide usage in the United States. Seven Maysmeters were used in the project. During their operation in a harsh environment, the devices themselves proved to be very durable.

The MRMs were supplied by the manufacturer with a pen and paper type graphical display unit (Figure 2.2). As the vehicle is driven over a road, the chart recorder displays a coarse road profile as it moves the paper at a rate proportional to the roughness of the road. Thus, the physical length of the strip of paper produced by the chart recorder is a measure of the roughness. A typical strip chart is shown in Figure 2.3.

Measuring the strip of paper to obtain roughness took approximately as much time as to generate it. In order to automate the data collection process while improving the reliability and productivity of the Maysmeter<sup>2</sup>, the Instrumentation Group developed a summation unit which replaced the chart recorder. The summation unit accumulates the roughness information produced by the Standard Rainhart transmitter and displays it at selectable intervals in a digital form.

The roughness measuring device used in this study consists of three major parts (Figures 2.4 and 2.5). The transmitter installed is shown in Figure 2.6 and senses the motion of the vehicle chassis relative to its rear axle. It is part of the Mays-Ride-Meter manufactured by Rainhart Co.. The Distance Measuring Instrument (DMI) measures the distance travelled by the vehicle. It is manufactured by Nu-Metrics. The summation unit combines the distance information from the DMI and the chassis motion information from the transmitter and produces a summation display at specified distance intervals. It was manufactured by the Instrumentation Group and its construction details are given in a Project Instrumentation Memo (Linder, "Digital Readout for the Maysmeter"). More details about each of the three parts are given in an-

---

<sup>2</sup>

It was later verified that, in addition, the chart recorder's stepper motor is unable to perform adequately on rough roads.

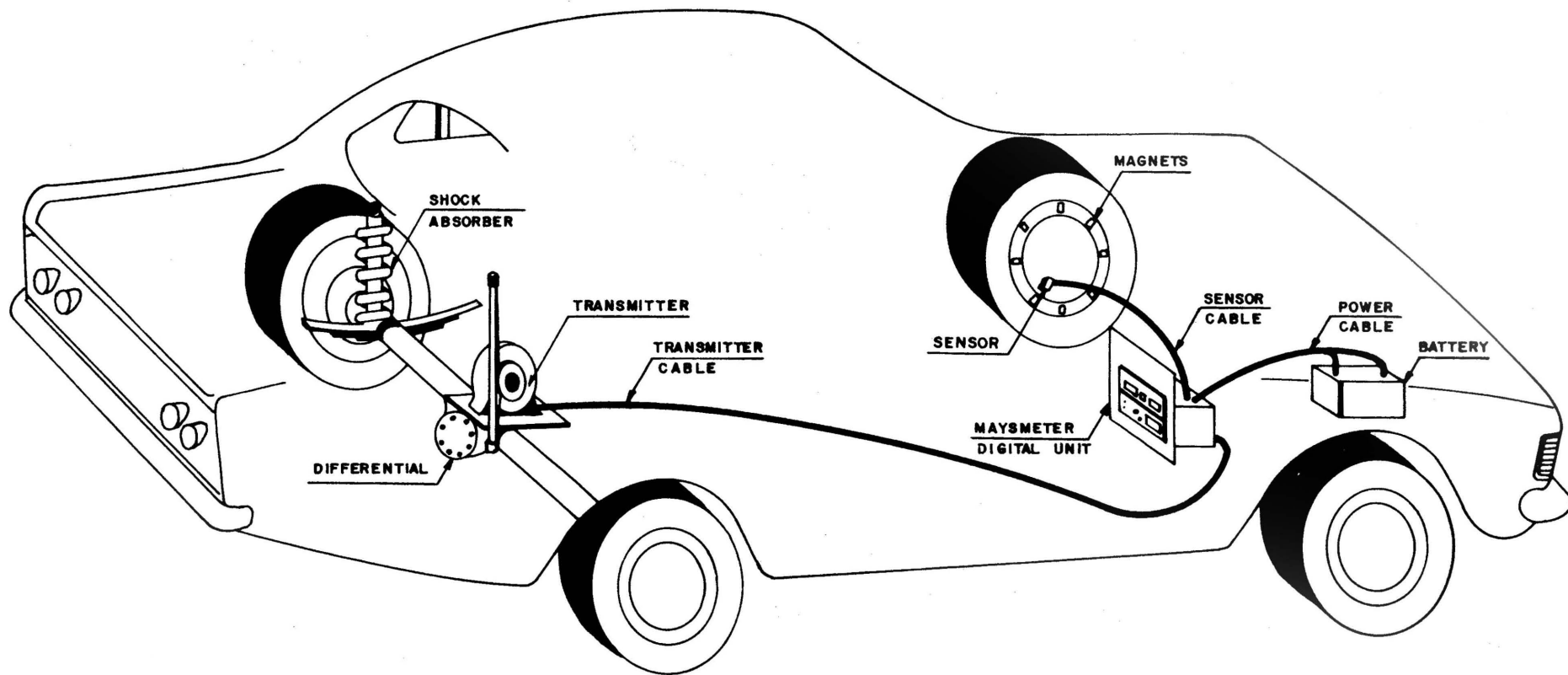

FIGURE 2.1 - MAYS METER INSTALLED IN A CAR

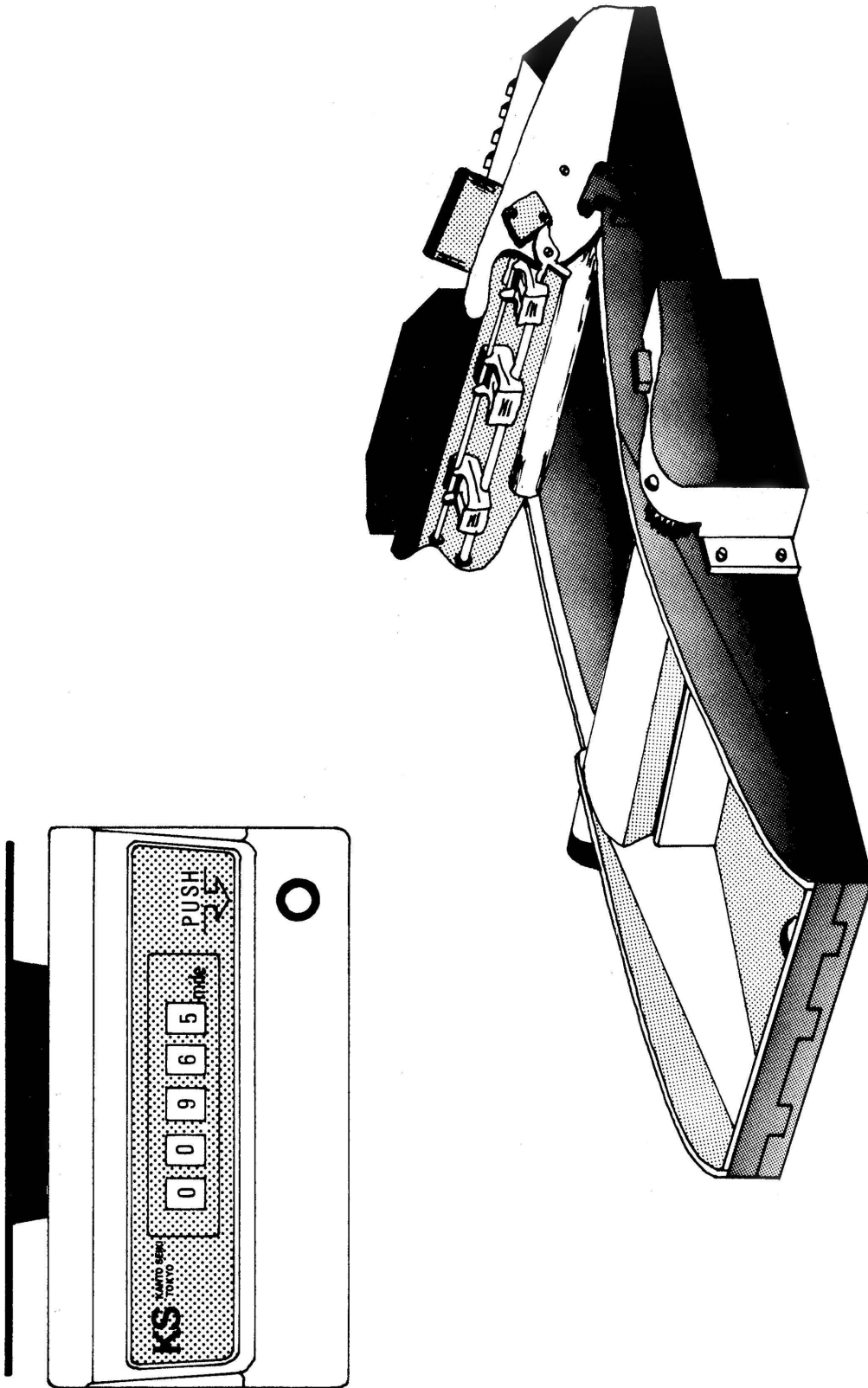

FIGURE 2.2 - GRAPHICAL RECORDER AND MECHANICAL ODOMETER

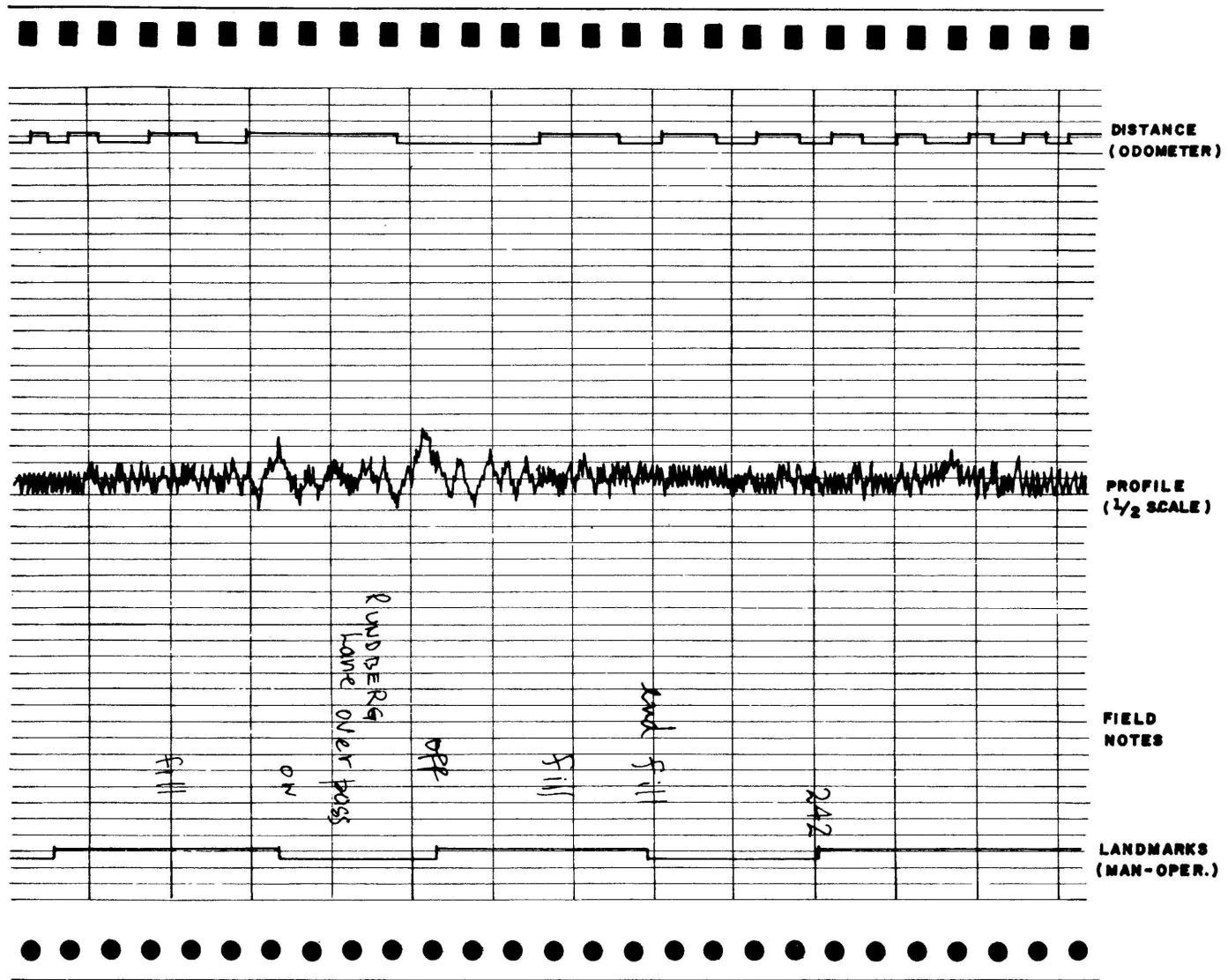

FIGURE 2.3 - GRAPHICAL MODEL CHART RECORDING

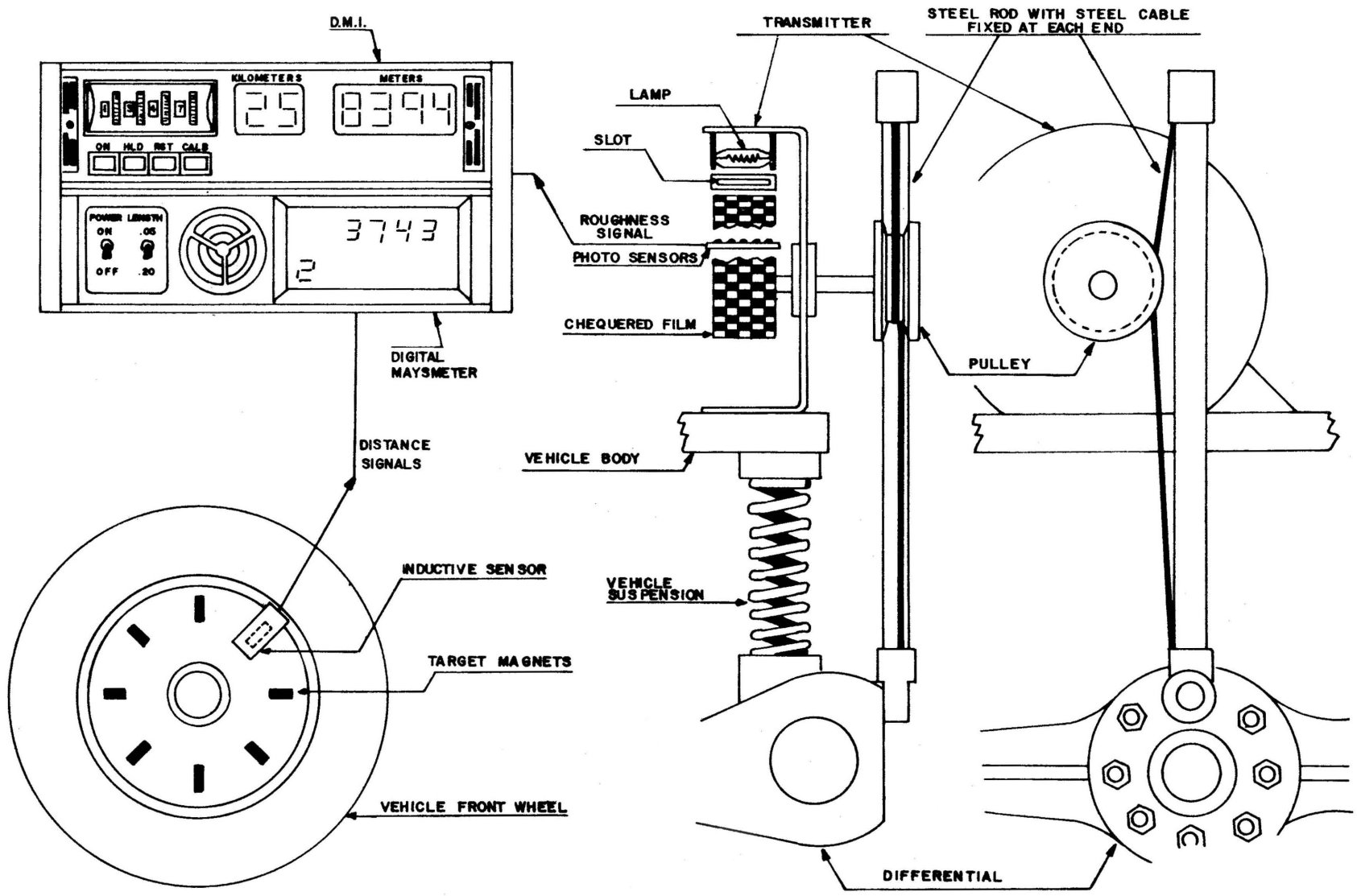

FIGURE 2.4 - MAYS METER BLOCK DIAGRAM

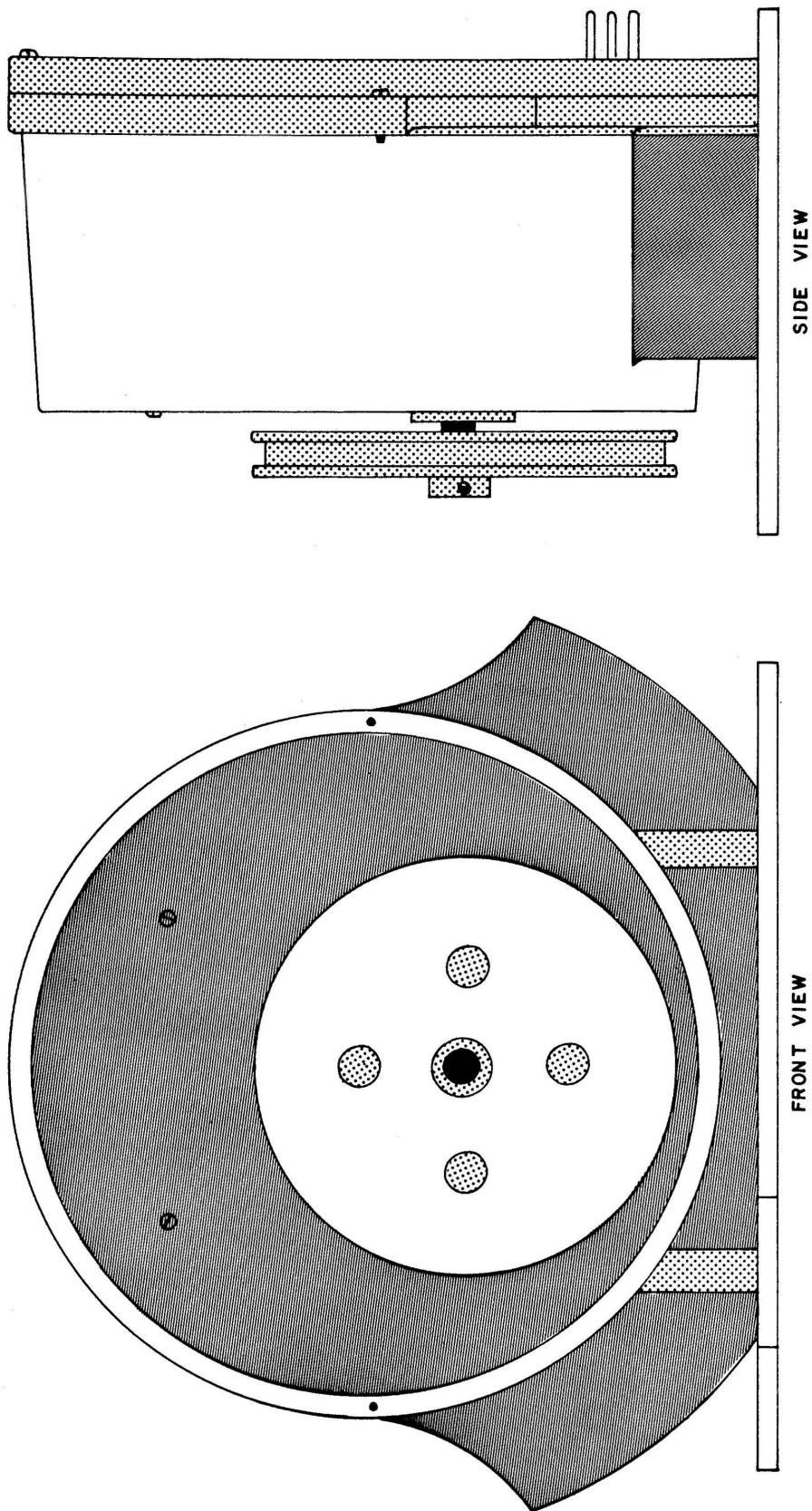

FIGURE 2.5 - TRANSMITTER

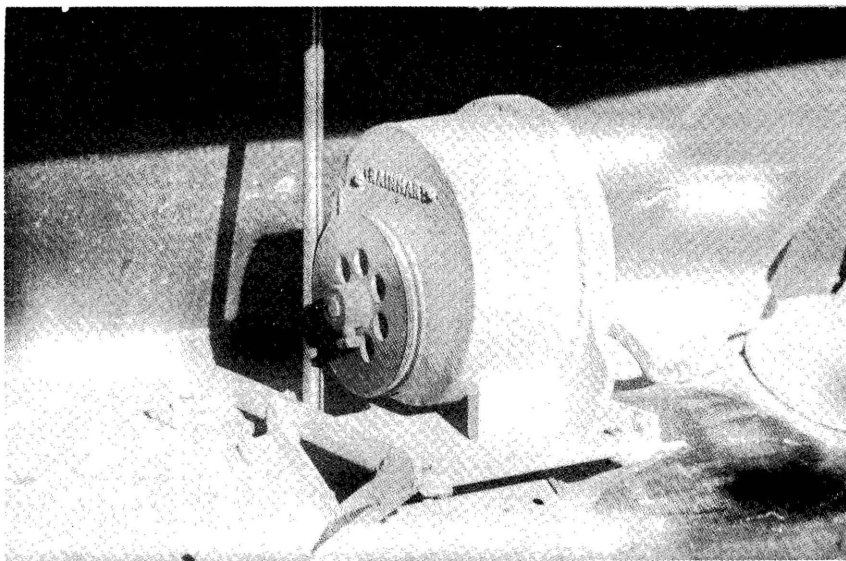

FIGURE 2.6 - MAYSMETER TRANSMITTER INSTALLED



TABLE 2.1 - SPECIFICATIONS FOR THE MAYSMETER SYSTEM

	DIGITAL OUTPUT	GRAPHICAL OUTPUT
MOUNTING		
Transmitter	Trunk	Trunk
Output Unit	Instrument Panel	Front Seat
Odometer	Instrument Panel	Instrument Panel
POWER	10 VDC to 14 VDC	10 VDC to 14 VDC
FREQ. RESPONSE (Roughness)	Limited by Res- ponse of Vehicle	Limited by Stepper Motor Response (200 Hz)
DIMENSIONS		
Transmitter	6.5"x7.5"x4.5"	6.5"x7.5"x4.5"
Output Unit	8.5"x 6"x 4"	11"x 18"x 8"
Odometer	Part of Output Unit	6"x 4"x 3"
SPEED	16 km/h to 80 km/h	Dependent on Roughness
OUTPUT DISPLAY	Digital Number Ap- pearing on Instru- ment Face	Strip of Paper from Chart Recorder with length Proportional to Roughness

other Project Memo (Linder, "Digital Readout Mays-Ride-Meter System"). The resulting vehicle unit, whose specifications are summarized in Table 2.1, was designated the Maysmeter system and is referred to as the Maysmeter.

### 2.2.1 *Operating Principle*

The Maysmeter registers the relative change of position between the vehicle's rear axle housing and its chassis as the vehicle moves along a road surface. The rougher the road surface becomes, the greater the up and down motion of the chassis relative to the rear axle. The motion is sensed by the transmitter which is driven by a rod attached to the vehicle's rear axle housing. The transmitter sends electrical impulses to the summation unit. The summation unit is shown in Figure 2.7 and produces a numerical output, proportional to the motion between the rear axle housing and chassis.

The summation device uses an electronic distance measuring instrument (DMI) to measure the distance of each road subsection under study. The DMI senses the passage of 8 target magnets fixed to the inner rim of the vehicle's left front wheel, which are shown being installed in Figure 2.8. The DMI then scales the number of magnets sensed to produce an output display and signal which is proportional to an operator adjustable distance measurement unit, e.g., miles, feet, meters, etc.

The DMI may be read directly by the observer at the same time that it sends electrical pulses to the summation unit, which collects them until either 500 or 2000 (selectable by the observer) impulses are accumulated. The summation unit then updates its display to read out the accumulated roughness impulses from the transmitter. Since the DMI may be calibrated in any distance unit, the 2000 impulses may be 200 meters, 0.2 miles, or any other unit of measure (similarly, 500 impulses may be 0.05 km, 0.05 miles, etc.).

### 2.2.2 *Field Operation*

The Maysmeter is sensitive to operating speed, primarily because of the vehicle's spring shock absorbers system. Therefore, it is

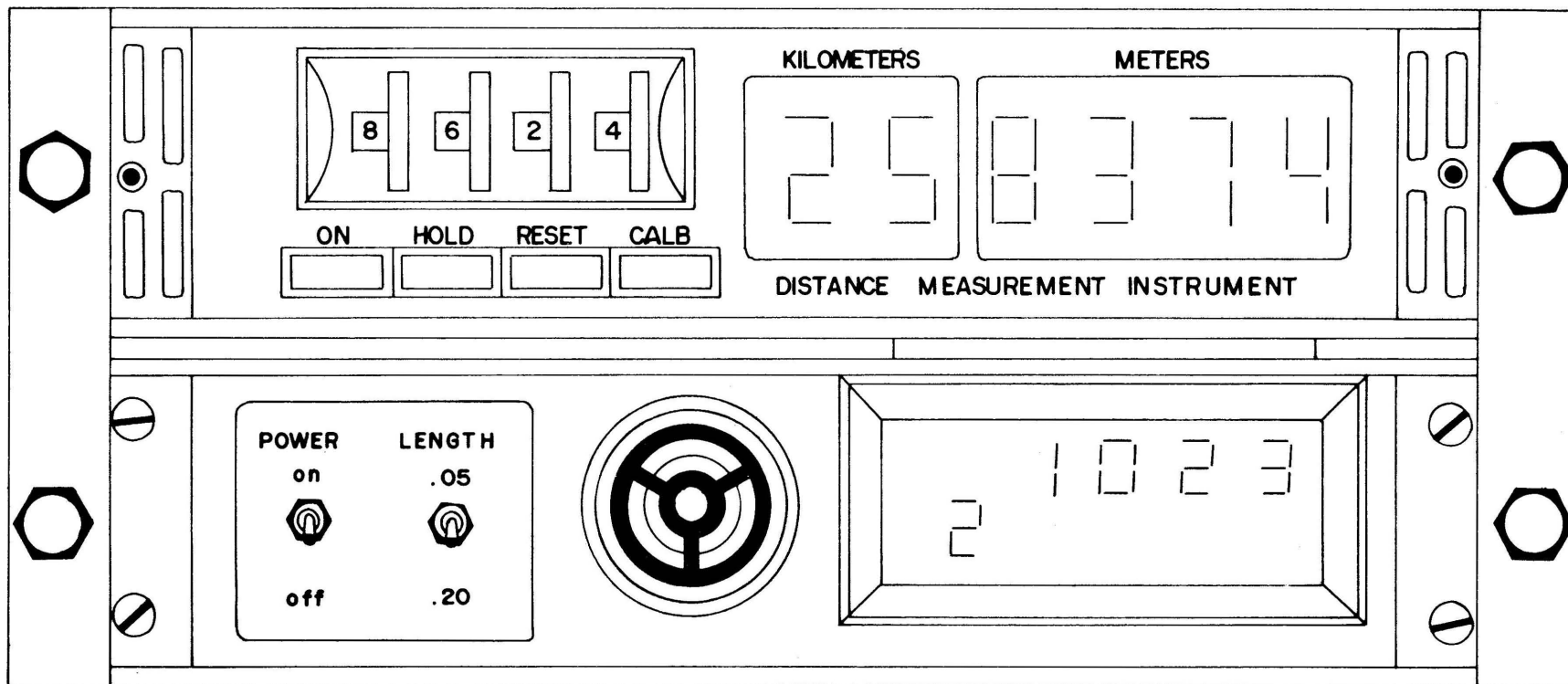

FIGURE 2.7 - DIGITAL ODOMETER (DMI) AND SUMMATION UNIT



FIGURE 2.8 - INSTALLATION OF MAGNETS ON TIRE RIM

necessary to establish standard fixed speeds for measurements. For the study three operating speeds were established, 20 km/h, 50 km/h, or 80 km/h, depending on the type of road. Correlation equations were developed to convert 20 and 50 km/h speed roughness results to 80 km/h values. These equations are presented on GEIPOT/PICR, Working Document No. 10, 1979. The validity of these equations for pavements other than asphaltic concrete is questioned by Alckmin *et al.*

The Maysmeter required a driver and an observer. The driver was carefully selected and trained to drive at a constant speed and not to swerve or turn abruptly, as such behavior introduces false data into the measurement device. The observer required very little training, but had to be able to assume overall responsibility for the crew and equipment. He instructed the driver to drive at a preselected standard speed appropriate to the road surface being measured. The observer also operated the Maysmeter device and recorded roughness information on the recording form, shown in Table 2.2.

The summation model is operated as follows: the observer holds the DMI reset switch in until the start of the section and jots down the roughness count for each sub-section on the recording form, along with identifying information. The recording forms are returned to the office upon the vehicle's return.

A normal operating schedule includes the following:

- Before the crew sets out with the Maysmeter for the measurement site, the vehicle and instruments are checked for defects.
- The Maysmeter is tested on established calibration sections.
- Once the Maysmeter arrives at its measurement site, it is again tested on previously established control sections in the area.
- During extended measurement programs in remote areas the Maysmeter is periodically checked against control sections established during the measurement program to continuously verify calibration.
- Following the completion of any Maysmeter measurement program and upon return to the Instrument Shop the unit is again checked on the headquarters calibration sections.

The headquarters control sections were monitored for change using the GM Profilometer, described in Section 2.3.

### 2.2.3 *Maintenance*

Some introductory comments are in order regarding the envi-



ronmental conditions in which the equipment was operated. Heavy summer rains caused unpaved roads to become slippery and muddy. In winter, the lack of moisture cause these same roads to become covered with a powdery dust which seeped through every small crack in the vehicle and equipment. The severity of road surface roughness caused fractures in the chassis of three Maysmeter vehicles. Several types of mechanical failure occurred on the seven vehicles, including collapsed suspension, broken motor mounts, torn-off exhaust systems, cut tires and bent wheel rims, dented fuel tanks, and general body damage.

Tires lasted about 20,000 kilometers and it was difficult to find sufficiently round ones for replacement. The normal procedure was to select each tire individually from the dealer's stock to ensure that the best ones available were being used on the Maysmeter vehicles.

#### 2.2.4 *Recommended Maintenance Facilities*

One electronics technician  
 One auto mechanic  
 Volt-Ohm meter  
 Oscilloscope (15MHZ) optional  
 Normal electronic hand tools  
 Normal mechanical tools

#### 2.2.5 *Major Sources of Maintenance Problems*

Little is known about how the graphical model Mays-Ride-Meter functions in the Brazilian environment because its use was discontinued very early in the project. Some problems were encountered, however, on very rough surfaces with the paper drive system of the chart recorder. The paper lost contact with the drive sprockets, causing an inaccurate roughness measurement.

The most recurrent problem was breakage of the transmitter bow-rod drive cable. The drive cable is a flexible steel cable similar to a bicycle hand brake cable. Although strong, it is susceptible to wear from friction. Fortunately, it was easy to replace and readily available in Brazil.

Other problem involved loose bolts and screws, caused by vertical vibration on very rough surfaces. Operator preventive maintenance, which might have abated this problem, could never be adequately

established.

The DMI sensor and target magnets were vulnerable to damage from flying stones or debris on unpaved roads. Sensors and magnets were also damaged by careless tire changes at local tire shops. The DMI Instrument failed on some vehicles due to environmental conditions, but more frequently it had electrical component failures. Three failures of the summation unit occurred from manufacturing defects.

The transmitter axle bearings were replaced on some units and the aluminum outer pulley was replaced with locally-made brass pulleys to increase their life span. The aluminum bow-rod and aluminum rod-to-cable clamp were replaced with stainless steel parts. Some problems were encountered with the transmitter photo cells, requiring the replacement of two units. The transmitter lamp needed to be replaced about once every six months due to heavy (daily) use.

## 2.3 PROFILOMETER

### 2.3.1 Introduction

The General Motors road surface dynamics Profilometer (Figure 2.9), manufactured under licence by K. J. Law Engineers Inc., was acquired to provide a reliable standard against which the Maysmeter results could be compared, to facilitate correlation among the seven Maysmeters. The Profilometer was thus used to establish and to monitor periodically the control sections used in the calibration of the Maysmeters. The correlation technique between Profilometer and Maysmeter was based on Walker and Hudson (1973).

The Profilometer experienced an abnormally high failure rate during most of the project. Important technical limitations of the instrument were found which restricted its use to smooth asphaltic concrete roads (GEIPOT/PICR, Working Document No. 10, 1979). Details are given in Section 2.3.4 on maintenance.





FIGURE 2.9 - PROFILOMETER IN OPERATION ON A TEST SECTION

### 2.3.2 *Operating Principle*

The Profilometer is a specially modified instrumented vehicle which, when driven over a highway, measures the road profile. Figure 2.10 illustrates the operating principle. The vehicle undercarriage has been modified to accept two spring-loaded pavement-follower-wheels. One wheel follows the right wheel path and the other the left wheel path. A linear potentiometer is connected between each follower-wheel axle and vehicle body to measure the distance between body and roadway. Two accelerometers are secured directly over the follower-wheels to sense the vertical motion of the body. The potentiometer and accelerometer signals are then electronically combined by the profile computer to cancel the body bounce and calculate the true road profile. The electrical representation of the road profile is registered continuously on a precision analog recorder for later analysis.

The Profilometer is also equipped with a Quarter-Car-Simulator. This is a special purpose analog computer designed to be used to process road profile data measured by the Profilometer. The processing of road profile data involves the analog simulation of a simplified vehicle. The measured road profile data is the input to this simulation. The reaction of the simulated vehicle to the measured road profile is the output. This output is in terms of the Roughness Index (RI) instituted by the Bureau of Public Roads, U.S.A..

The Profilometer is also equipped with a two-channel strip chart recorder. This graphic recorder is used to register the profile computer outputs during the calibration process.

The processing and recording instruments of the Profilometer are illustrated in Figures 2.11 and 2.12. The specifications of the Profilometer are summarized in Table 2.3.

### 2.3.3 *Field Operation*

The Profilometer was operated at 16 km/h on very rough surfaces and at 32 km/h on normal paved surfaces. Although, according to the manufacturer, the Profilometer may be operated at any speed, practice showed that there are important speed limitations that, if ignored, will lead to inaccurate operation and to equipment damage (GEIPOT/PICR, Working Document No. 10, 1979).

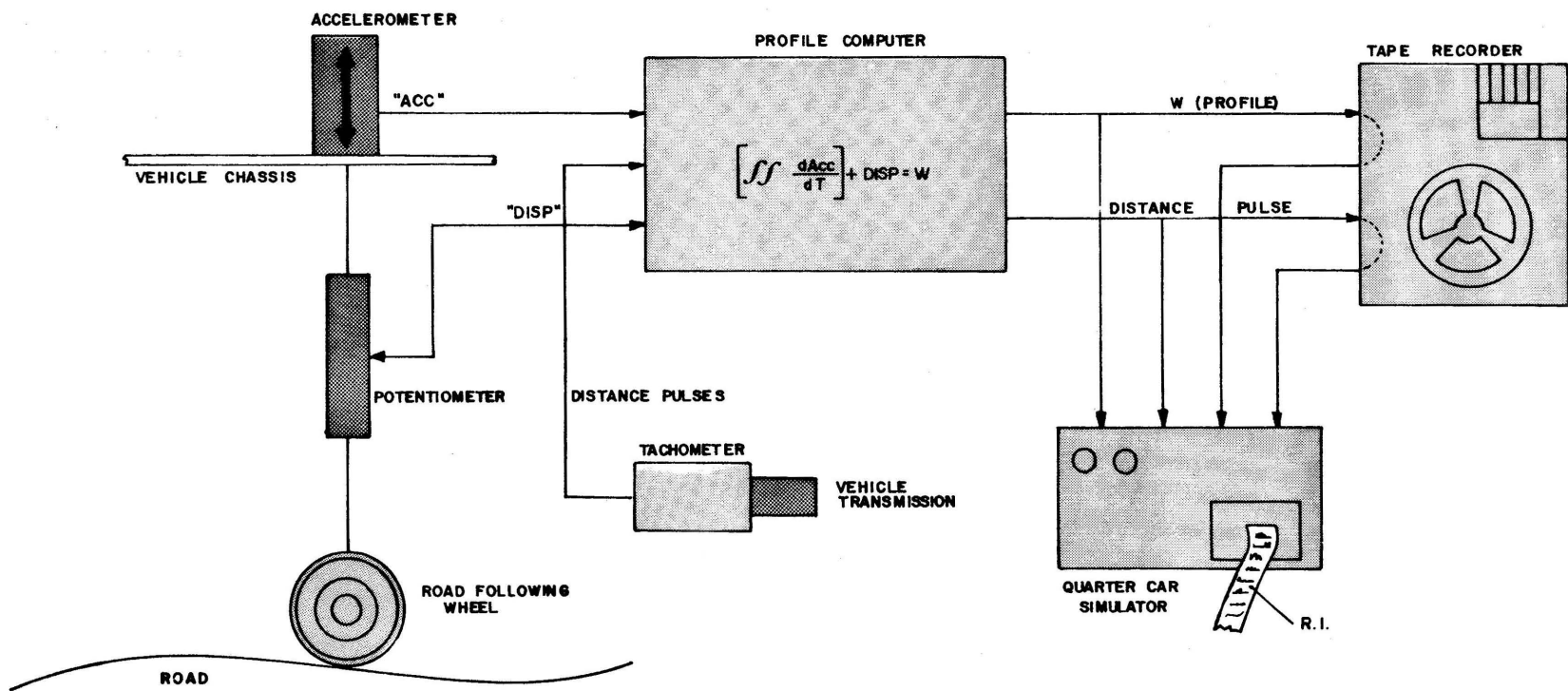

FIGURE 2.10 - PROFILOMETER BLOCK DIAGRAM

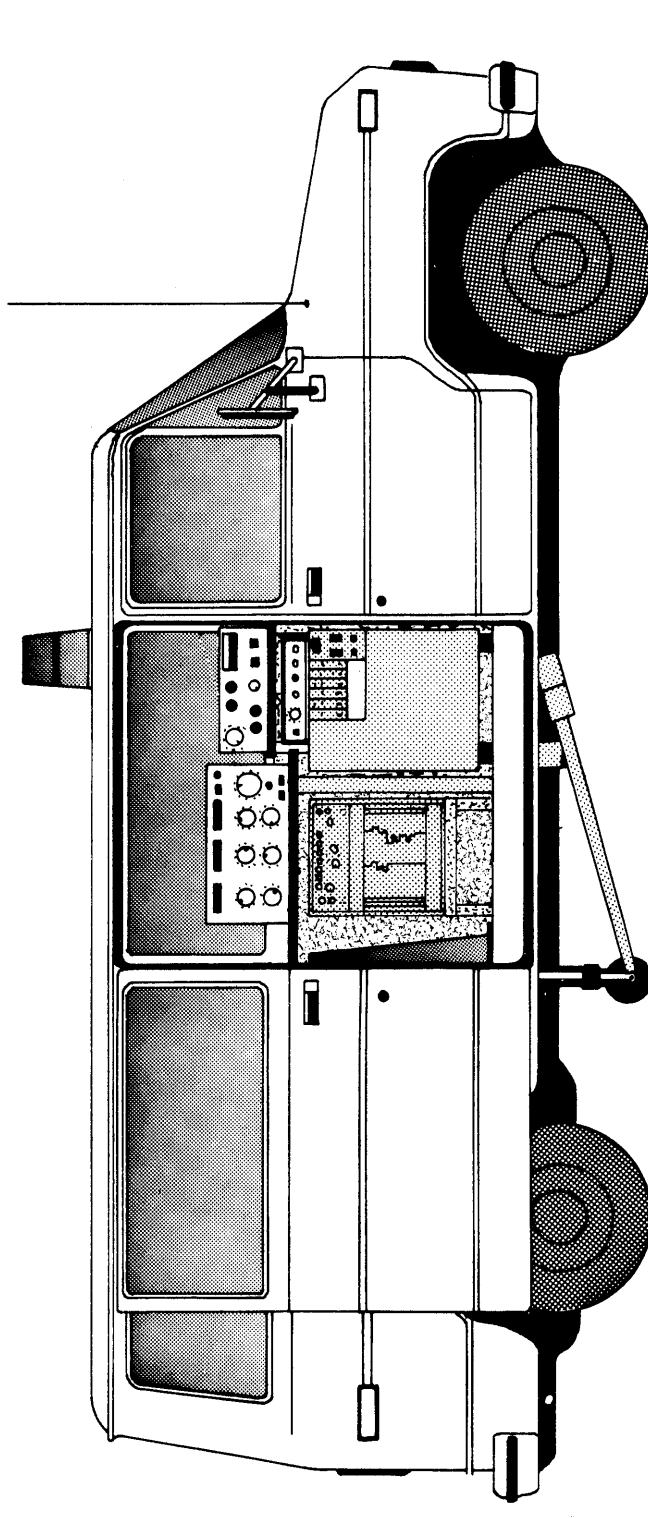

FIGURE 2.11 - PROFILOMETER

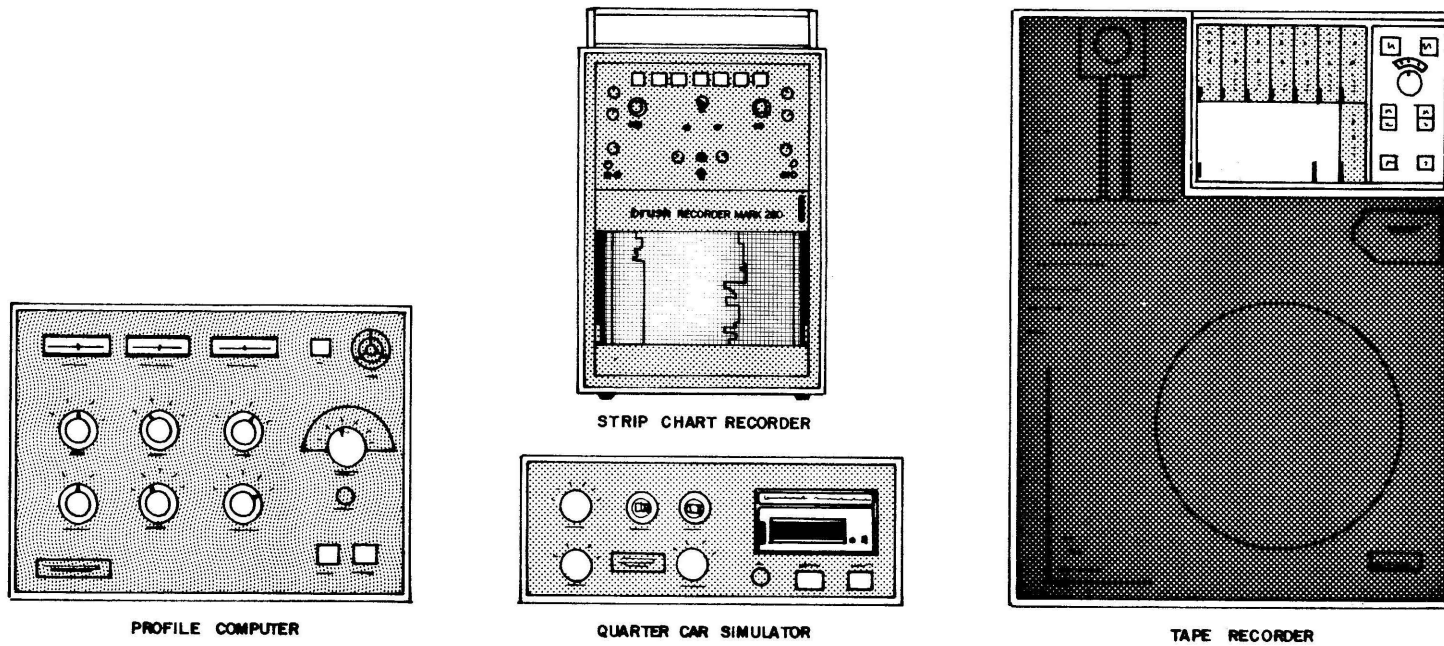

FIGURE 2.12 - PROFILOMETER PROCESSING AND RECORDING INSTRUMENTS

TABLE 2.3 - SPECIFICATIONS FOR THE PROFILOMETER

MOUNTING	All Profilometer components are installed in a medium weight Ford panel truck
POWER	Power self generated by alternators mounted on vehicle's engine
ROUGHNESS RESPONSE	Selectable by filter and gain setting and operating speed
SPEED	10 MPH to 50 MPH <sup>1</sup>
REPEATABILITY	± 1% <sup>2</sup>
OUTPUT	Profile recorded on analog tape RI index printed on paper

NOTES: <sup>1</sup> Standard speed should be established to assure best results. Higher speeds feasible only on very good roads.

<sup>2</sup> Chiefly dependent on the skill of the drivers.

The Profilometer's crew consisted of a driver and an operator. Accurate driving is critical since many road surfaces exhibit considerable transverse roughness gradients, and if the measuring equipment (Profilometer, Mays-Ride-Meter, etc.) is not driven over exactly the same wheel paths, repeat roughness measurements will vary for the same road. Thus, it is normal on patched roads to get a larger spread in repeat measurements than on very smooth roads. This is not so much a function of the measuring device's repeatability as a function of driver's repeatability. Therefore, the driver must be selected and trained with care if good results are to be obtained.

The operator had to be a mature individual, capable of making judgements as to the safe usage of the Profilometer on a particular surface, especially if the surface was in poor condition. The studies were to include unpaved and badly deteriorated paved roads. After many breakdowns had occurred, it was established that the Profilometer was not to be used if there was a possibility of damaging the measuring device. Later, the use of the Profilometer was restricted to smooth asphaltic concrete roads after it was found that this was the only type of road where the measurements were accurate, besides being safe. The operator instructed the driver and operated the computers and the tape recorder. The operator required substantial training before he was able to recognize Profilometer malfunctions and gain the experience necessary to enable him to correctly choose the gain and filter settings needed to achieve the best possible results from the Profilometer.

The operating procedures followed for the Profilometer were as follows: the Profilometer was stopped on the road, 200 to 300 meters in front of a measurement section of known length. The Profilometer's road-following-wheels were lowered, the profile computer reset and the operator entered verbal identifying information on the tape recorder. The driver started a gentle acceleration to the operating speed using the 200 to 300 meter stretch for that purpose. The operator entered the "start of section" signal on the tape recorder via voice or an event switch. As the Profilometer passed the end of the section, the operator entered the "end of section" signal to the tape recorder in the same way and raised the road-following wheels. When the Quarter-Car-Simulator was used, its printed tape output was annotated to reflect identifying information. Both the tape recording of the profile and the Quarter-Car-Simulator tape were returned to the office for analysis.

#### 2.3.4 Maintenance

The Profilometer experienced an abnormally high rate of failure during most of the project's duration. Early in the project there were numerous electronic component failures in both the profile computer and Quarter-Car-Simulator. Some design and manufacturing errors were found in the circuit boards and corrected. Many components were replaced, and then the failure rate decreased considerably. This allowed the Profilometer to go to the field, revealing a major problem: potentiometer breakage. The potentiometer is the sensor that registers the change in position between the road-following wheel and the vehicle's chassis. Although the original potentiometers chosen by the Profilometer manufacturer were also used on large aircraft to sense the landing gear position, they failed to be durable enough for the Profilometer. Two original and four spare potentiometers were broken, repaired and broken again. The problem was solved only after a new pair of potentiometers was built by a potentiometer manufacturer especially for the project Profilometer, and with the reduction of the operating speed.

The change in the Profilometer operating speed revealed a design problem in the Quarter-Car-Simulator: the RI index was sensitive to the collection speed as well as to the simulation speed. The manufacturer was contacted and admitted that there was an error in one of the circuit boards. A diagram showing the changes to be made in the QCS circuit board was sent by the manufacturer but correcting factors were adopted instead, the circuit being left as it was (GEIPOT/PICR, Working Document No. 10, p.5, 1979).

Two accelerometers failed because of excessive Profilometer vibration. These failures occurred early in the project and the replacement accelerometers gave no problems.

An unusual failure occurred involving the torsion bars which hold the road following wheels to the road surface. Both torsion bars broke. The Profilometer manufacturer contacted the Chrysler Corporation Engineering Department and learned that if the torsion bars were allowed to remain wet they would break at an accelerated rate compared to normal. New bars were installed with a heavy coating of grease. No further torsion bar failures occurred.

The electrical system of the Profilometer was supplied by two alternators and battery sets. Each received a very heavy demand. Each



failed on occasion, but this problem was considered normal and one that could be expected to recur.

The hydraulic system used in raising and lowering the road following wheels developed leakage from time to time. This was considered normal in view of the very high hydraulic pressure and the heavy usage of the Profilometer. A gas-charge booster tank developed a pin hole and was repaired by soldering.

The graphic recorder Brush Mark 280 (Clevite Corporation), used in the profile computer calibrations, presented increasing problems and was finally taken out of the Profilometer when it was no longer possible to repair it locally. This was an obsolete model graphic recorder built with technology from the late 50's. To replace it a UV graphic recorder was borrowed from the soils laboratory whenever it was necessary.

The Sangamo Sabre II tape recorder used in the Profilometer had electrical component failures which were a major source of Profilometer downtime from the middle of the project on. The recording and reproducing heads wore out extremely fast with use. The manufacturer was contacted and recommended changing the tape type. The record/reproduce heads were changed (approx. cost US\$4,000) and the type of tape recommended was adopted. However, the new heads wore out as fast as the original ones. It was learned later that the recorder supplied with the Profilometer turned out to be one manufactured by Sangamo during a period of experimentation. Once this information was discovered, the recorder was shipped back to the factory and repaired at the manufacturer's expense. Even after the repairs, the recorder failed to give acceptable service. This recorder is not considered sufficiently robust for service in the Profilometer.

### 2.3.5 *Recommended Maintenance Facilities*

One electronics engineer  
 One senior electronics technician  
 One mechanic  
 Digital volt-ohm meter, 3 1/2 digits  
 Oscilloscope  
 Function generator, 1 HZ to 10KHZ  
 Frequency counter  
 Normal electronic hand tools  
 Normal mechanical hand tools



CHAPTER 3  
THE SURVEY VEHICLE



### 3.1 INTRODUCTION

Two survey vehicles were constructed by the Measurement Instrument Group to measure rapidly, from a moving vehicle, roadway grade, horizontal curvature, distance and roughness. The general configuration of the instruments is depicted in Figure 3.1 and the instrument panel in Figure 3.2. Fabrication details for the survey vehicles are presented in a Project Instrumentation Memo (Linder *et al.*, "Design and Operation of the Instrumented Survey Vehicles"). The general specifications are shown in Table 3.1.

### 3.2 GRADE METER

The grade meter is a specially constructed instrument that uses a linear accelerometer shown in Figure 3.3 as a grade sensing device. Other types of grade sensing devices were evaluated. These included: an aircraft "artificial horizon" gyro dive/climb instrument, a spirit level, a ball level, a U-tube level, and several configurations of pendulums. None of these devices proved as accurate, easy to read, easy to construct, or as durable as the accelerometer. The "artificial horizon" showed promise at the outset, but due to fluctuations (which are normal for gyro instruments), it was finally rejected.

The ball level consisted of a one-meter radius section of glass tube with a steel ball suspended in a damping fluid. It was in use for a period but showed that even the slightest amount of impurity in the damping fluid would cause the ball to stick in its glass tube. The glass tube proved extremely difficult to construct. Of the twenty tubes built for the PICR by a professional glass worker, only two were usable. Even these two were not bent to a perfectly smooth curve, which caused the ball to move in a non-uniform manner at the deviant points in the tube. The ball level is a feasible, low cost, grade-measurement device if suitable construction facilities are at hand. This instrument is being successfully employed in Australia.

The pendulum, while a serviceable method, would have been too large and costly to construct. The accelerometer is also a type of pendulum, but its two cubic inch volume and ready-made mechanical and electrical features made it very easy to implement. All that was needed

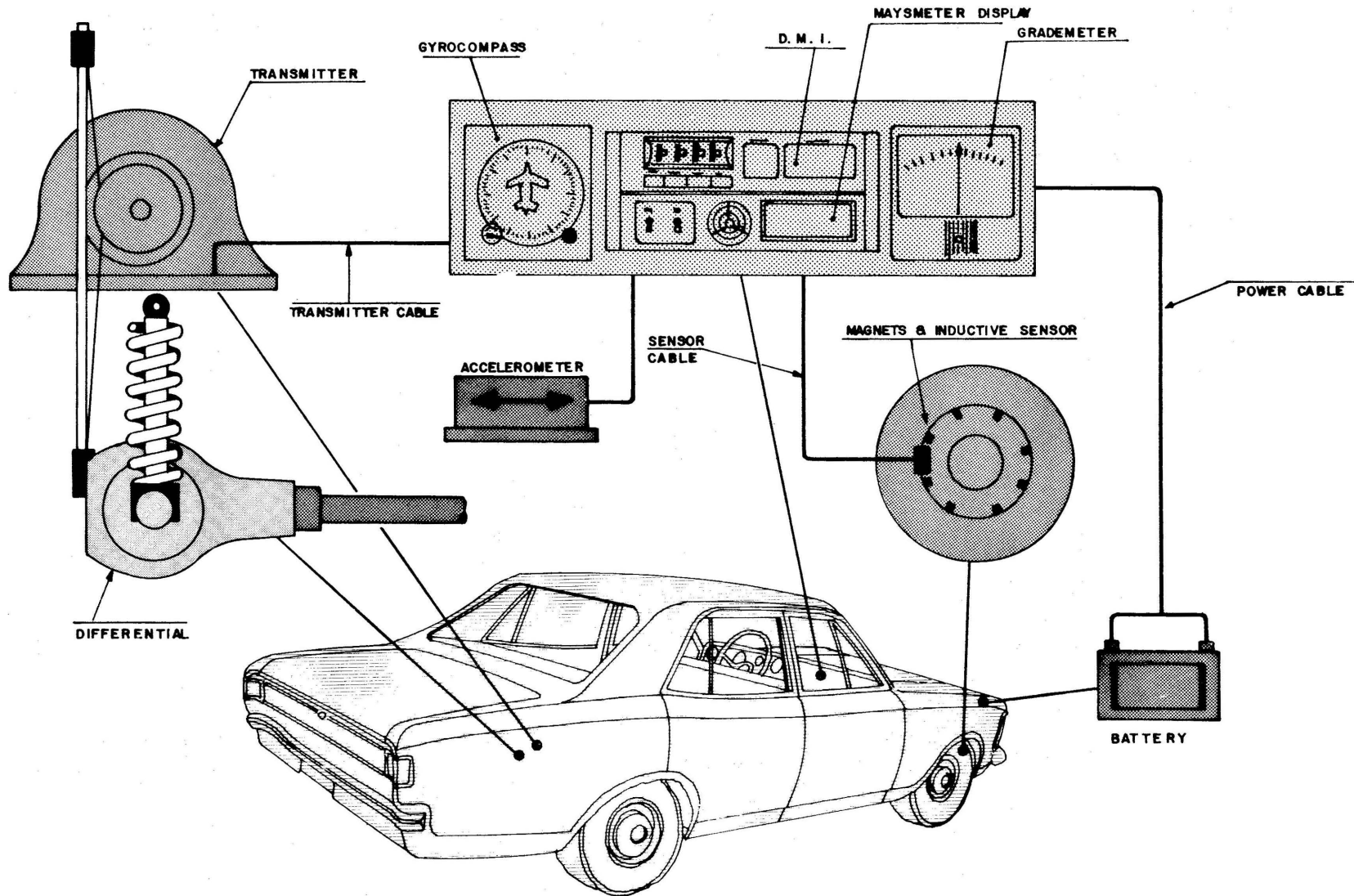

FIGURE 3.1 - SURVEY VEHICLE

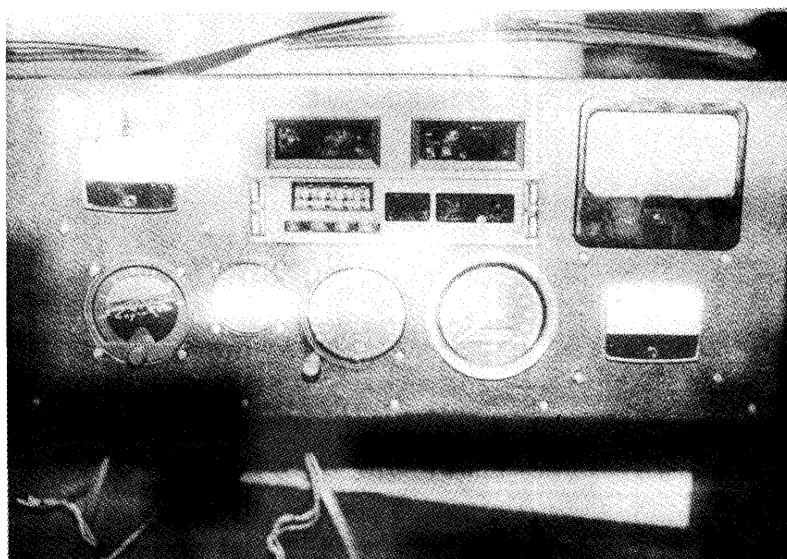

FIGURE 3.2 - SURVEY VEHICLE PANEL SHOWING DMI, MAYS METER,  
GYROCOMPASS AND GRADE METER DISPLAY

TABLE 3.1 - SPECIFICATIONS FOR THE SURVEY VEHICLES

GRADE METER	
Resolution	$\pm .25\%$ grade units
Repeatability	$\pm 10\%$
Power	7 VDC to 37 VDC
Damping	Infinitely adjustable
Output	$\pm 12\%$ grade panel meter
GYRO COMPASS	
Resolution	5° curvature
Repeatability	100% for practical purposes
Power: Pneumatic	1 7/8 cubic feet of air per minute
	14 VDC
electric	14 VDC
Output	Rotating dial on instrument face
D M I	
Resolution	$\pm 10$ centimeters (depending on the number of magnets on wheel)
Repeatability	$\pm 1$ meter
Power	7 VDC to 37 VDC
Output	6 digit incandescent display
MAYSMETER	See Table 2.1, Chapter 2



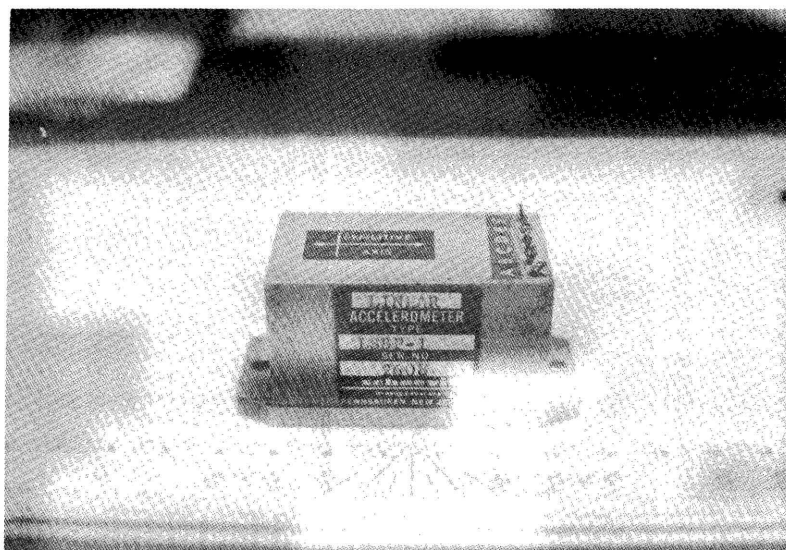

FIGURE 3.3 - ACCELEROMETER USED TO DETECT GRADE

to convert its output to a grade representation was a power source, a simple signal conditioning circuit and a panel meter. Figure 3.4 shows a block diagram of the survey vehicle. Figure 3.5 illustrates the panel meter. Vehicle construction details are presented in a Project Instrumentation Memo (Linder, "Accelerometer-Based Grade Meter").

The accelerometer grade meter is sensitive to vehicle speed changes. These accelerations act on the grade meter in the same manner as a change in grade. Electrical damping (infinitely adjustable) was added to the grade meter to eliminate short duration accelerations from road surface roughness. The long-term accelerations, due to vehicle speed drift, affect the grade meter output. This error depends on the magnitude of the vehicle speed drift and also on the road grade itself. The smaller the road grade, the greater the influence of the vehicle speed drifts. As an example, if the grade meter is operating on a 7% grade and the vehicle's speed changes uniformly by 5 kilometers per hour in 20 seconds, a 10% error will be introduced into the reading. Such a rapid speed change is not considered careful driving. Unlike purely mechanical instruments, the accelerometer grade meter does lend itself to error correction techniques.

A problem common to all vehicle mounted grade detection devices is "when to read the grade". If the vehicle is operating on a road with an extremely uneven surface, the vehicle will frequently be at a grade angle which is not representative of the average grade of the road. In such cases it must be left to the observer's judgement to determine points on the road which are suitable for measurement. The alternative is to take an enormous number of readings and average them. This method is not practical for high-speed survey techniques where the data is taken manually and reduced the same way. The accelerometer grade meter does lend itself to automatic data taking and reduction which could solve this problem.

### 3.3 HORIZONTAL CURVATURE METER

The horizontal curvature meter depends on an aircraft directional gyro compass. Two types were used, one pneumatically-driven and the other electrically-driven. The pneumatic model is less expensive and lasted through two and one-half years of use under severe environmental conditions. The electrical model should outlast the pneumatic

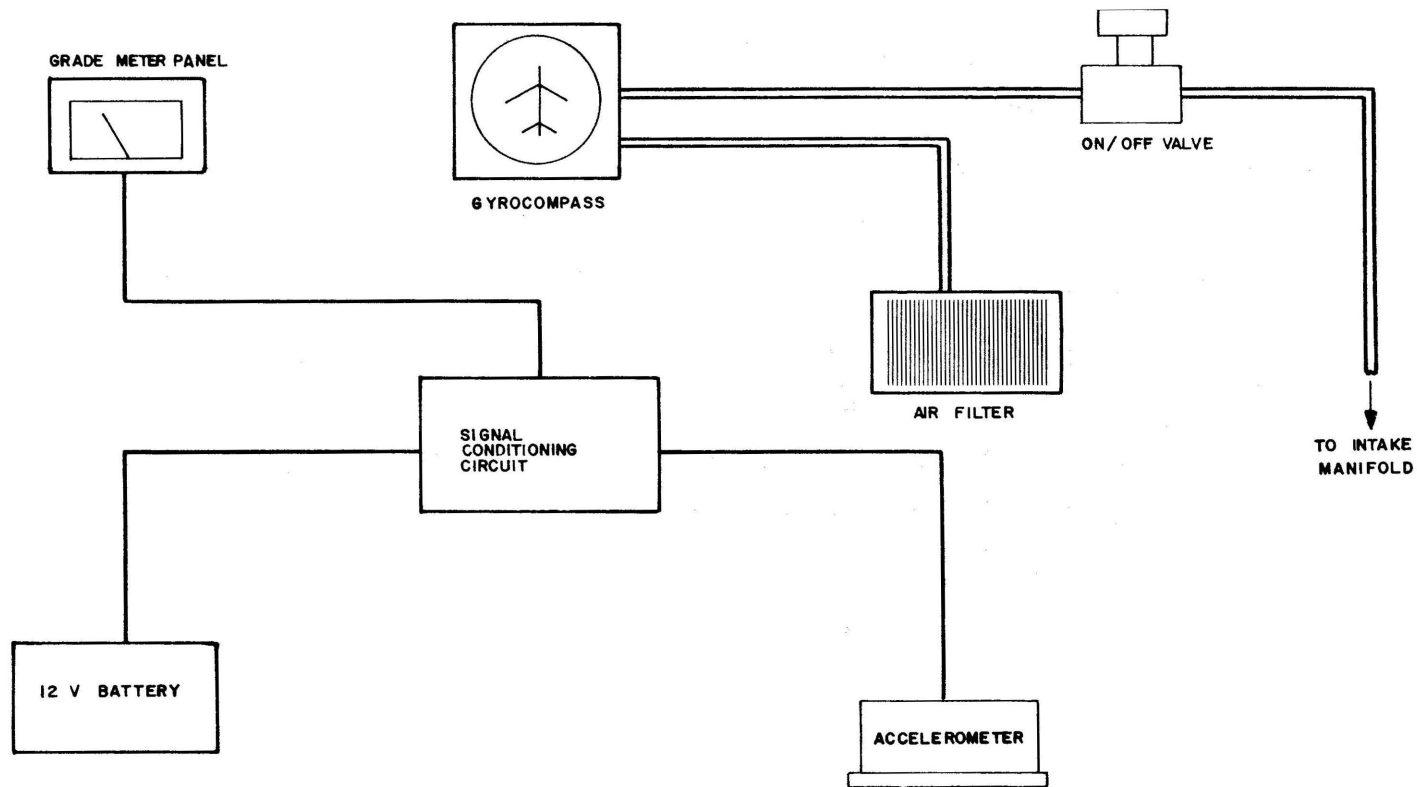

FIGURE 3.4 - BLOCK DIAGRAM - GRADE METER AND GYROCOMPASS  
IN THE SURVEY VEHICLE

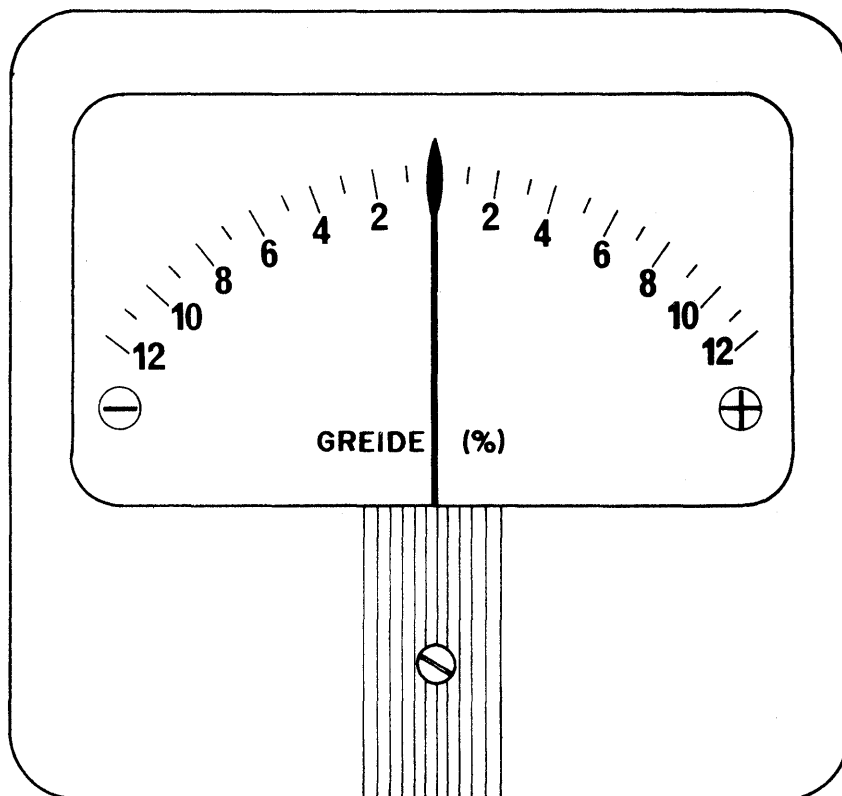

FIGURE 3.5 - GRADE METER DISPLAY

model several times over because it is sealed against dirt which is the major cause of the pneumatic's motor wear. However, the lower cost model is recommended based on project experience. Both units take about 15 minutes to reach operating speed after initial turn-on and exhibit the same long and short-term stability. The gyro compass was chosen because of successful use in Australia. No other direction detection devices were considered. The display of the gyro used in the project is shown in Figure 3.6. Further details on this device are presented in a Project Instrumentation Memo (Linder, "Directional Gyro").

### 3.4 DISTANCE METER

Road distance measurements were obtained using the DMI, a precise, low cost, electronic odometer. This device measures distance by converting revolutions of the front wheel of the vehicle into a digital display of distance travelled. Instrument reliability is primarily limited by the vulnerability of the wheel revolution sensing device. The front vehicle wheel is fitted with eight magnets. A magnetic sensor is mounted near the magnets, on the steering arm. These may be damaged by stones, road debris or by careless tire replacement. Some electrical problems did occur with the DMI's signal conditioning and display unit. The problems were easy to repair for a qualified electronics technician. The switches of the DMI wore quickly at the beginning of the project. This was caused by excessive use of the switches and by dirt in the dry season. The DMI is a part of the Maysmeter system. A detailed description of the DMI is presented in a Project Instrumentation Memo (Linder, "Distance Measuring Instrument - DMI"). The DMI panel is shown in Figure 3.7.

A mechanical odometer was tried and rejected because of mechanical lash-up problems, i.e., namely, the vehicle's speedometer drive cable is required to drive both the observer's odometer and the driver's speedometer. To gain accuracy, an adjustable ratio gear box is needed to correct the odometer drive speed. This additional strain, caused by the gear box and extra odometer, resulted in early failures of the drive cable. Although the mechanical odometer is cheaper, its resolution is much lower than the DMI's and it is more trouble-prone.

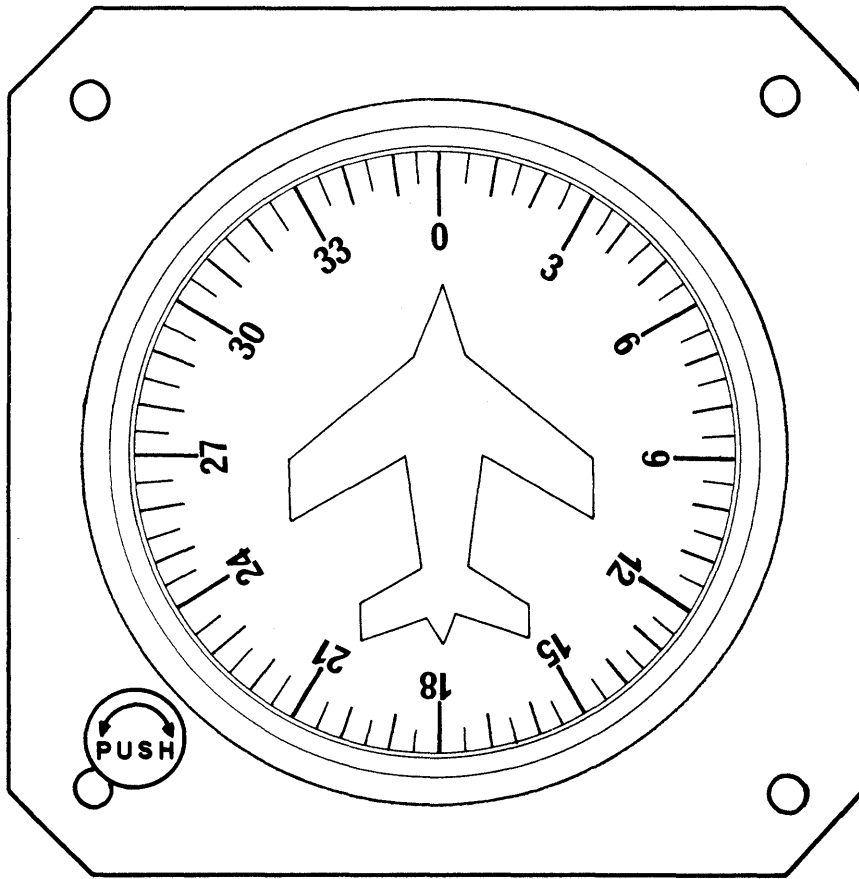

FIGURE 3.6 - GYROCOMPASS DISPLAY

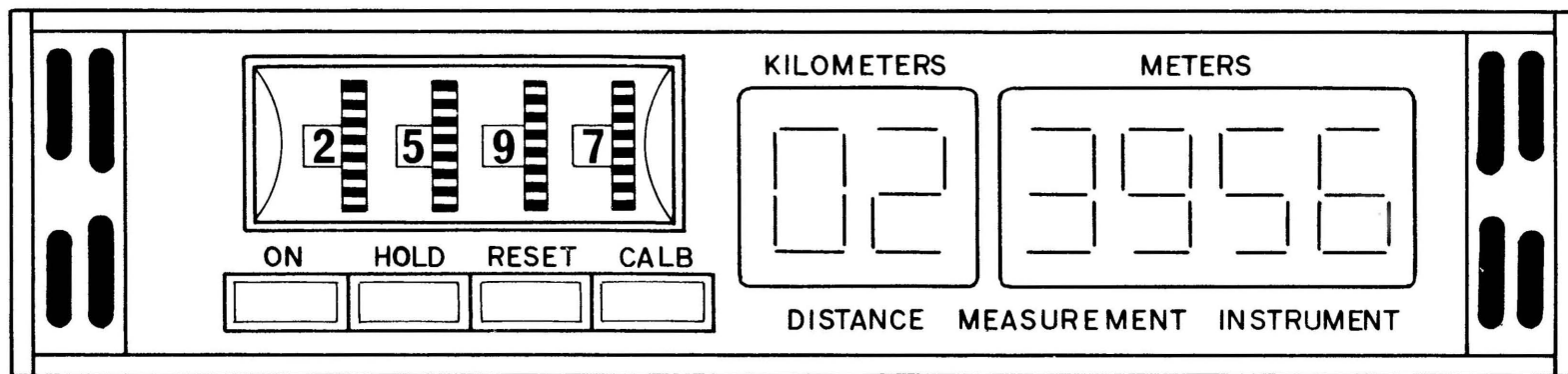

FIGURE 3.7 - DIGITAL ODOMETER (DMI)

### 3.5 ROUGHNESS METER

The road roughness measuring equipment is the Maysmeter system which was described in Chapter 2.

### 3.6 FIELD OPERATION

Good grade and roughness measurements require that the vehicle be operated at a constant speed. On grades, the actual speed is not important as long as it is kept constant. For the roughness measurements, the speed must be kept both constant and at a preselected standard speed. Constant speed is not required for horizontal curvature measure and distance measure, but in the case of curvature the speed must be slow enough to allow the observer time for his notations.

Accurate control of the vehicle is the responsibility of the driver. The skill necessary to drive in such a manner is not possessed by all individuals, so care is needed in selecting a driver who can perform satisfactorily. The observer requires no special skills. He should be a mature individual capable of assuming responsibility for the equipment and measurements. He must take the measurements and write them on the recording forms. His judgement concerning measurement conditions has a great impact on the quality of the recorded data. Ideally, the two crew members should be interchangeable to allow each a break from the routine.

Extracting data from instruments requires reading the display of the individual instrument and recording the numbers on a form. This task proved difficult on very rough surfaces because the grade meter pointer of the panel meter moved continuously. For roughness extremes, sections were run at a lower speed. The observer could not record all of the instruments in the survey vehicle simultaneously, so separate runs were required for geometry and roughness measurements.

### 3.7 OPERATING PROCEDURES

The grade meter is read and recorded as a grade is approached.



It is read and recorded again once the vehicle is well into the grade, and again at points on the grade. The horizontal curvature meter is read (it may be set right on a division mark if desired) just before the start of a curve, as is the DMI distance measure. Both are read again just after the end of the curve. The readings are recorded on the form shown in Table 3.2. Further description of the field use of the survey vehicle is outlined in a Project Technical Memo (Linder *et al.*, "Design and Operation of the Instrumented Vehicle").

### 3.8 MAINTENANCE

The horizontal curvature meters required no repairs, although the air filter on the pneumatic model needed changing at six-month intervals.

One grade meter required a new power supply unit. The other grade meter was fitted with a new panel meter after the original developed stiffness in its pivot bearing. This was very good service considering the harsh treatment that the equipment received.

Both vehicles were originally lightweight Chevrolet "Caravan" station-wagons. Both were eventually replaced with lightweight Chevrolet Opala passenger cars because of fractures in both station-wagon chassis.

### 3.9 RECOMMENDED REPAIR FACILITIES

One qualified electronics technician  
One mechanic  
Volt-ohm meter  
Normal electronic hand tools  
Normal mechanical hand tools



CHAPTER 4  
TRAFFIC BEHAVIOR  
MEASURING EQUIPMENT



## 4.1 INTRODUCTION

Three basic types of equipment were used to determine vehicle behavior under specific geometric and traffic conditions with regard to speed and changes in speed. The equipment included a radar speed meter, a photographic speed and time recording unit (camera box) which was later replaced by a tape recorder version (recorder box), and a tachograph.

Also used, although in a very limited scale, were the Photo Electric Light Intensity Detector (PELID), for evaluating the effect of dust on traffic behavior, and the Traffic Flow Data Logger, developed to record traffic parameters indicative of congestion effects.

## 4.2 RADAR

The radar unit used was the TR6 speed radar, manufactured by Kustom Signal, Inc.. Four units were acquired. Three were used in the field and one was kept as a spare. The TR6 system consists of three pieces: Figure 4.1 shows the indicator; Figure 4.2 the antenna and tripod; and Figure 4.3 the power source. The power source was manufactured by the Instrumentation Group using a high-capacity 12-volt truck battery enclosed in a wooden box with carrying handles. The box had an automobile cigar lighter socket to mate with the plug supplied by the radar manufacturer.

### 4.2.1 *Field Operation*

Since the radar was used in several different traffic behavior experiments, various procedural configurations were used to obtain the particular information wanted. In the case of speed changes while descending or ascending a grade, three mirror boxes were placed down the road from each radar antenna. The mirror boxes were built by the project staff and one is illustrated in Figure 4.4. As the vehicle passed a mirror box (Figure 4.5), the observer noted the speed on the radar readout (Figure 4.6) and then recorded the vehicle's speed. In this way nine points on a grade could be monitored with three radar sets. In

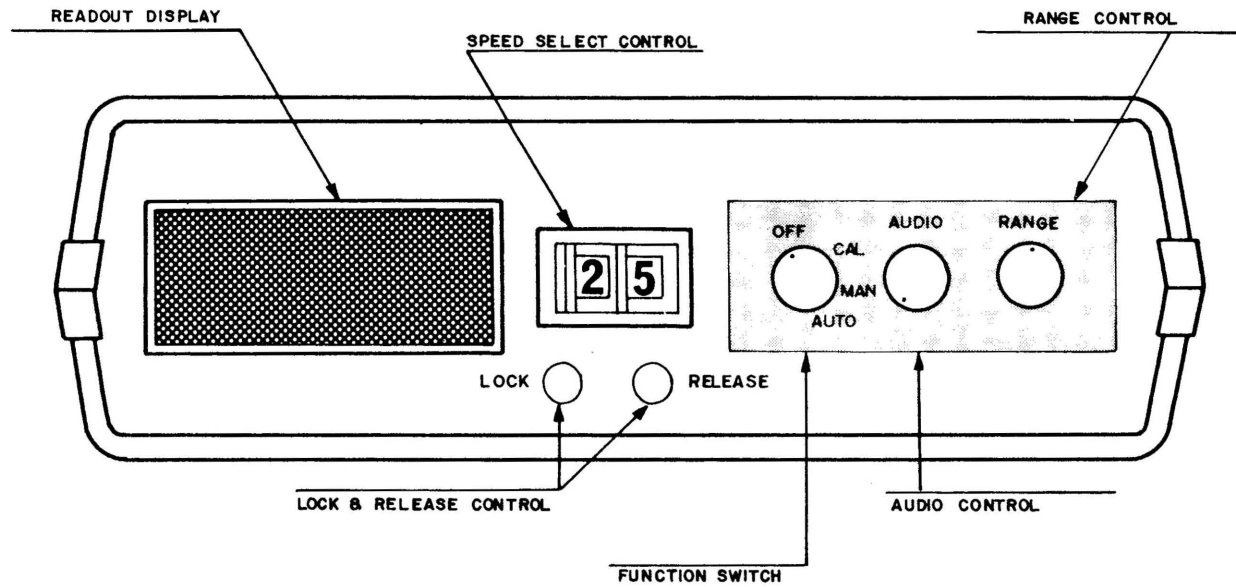

FIGURE 4.1 - RADAR PANEL

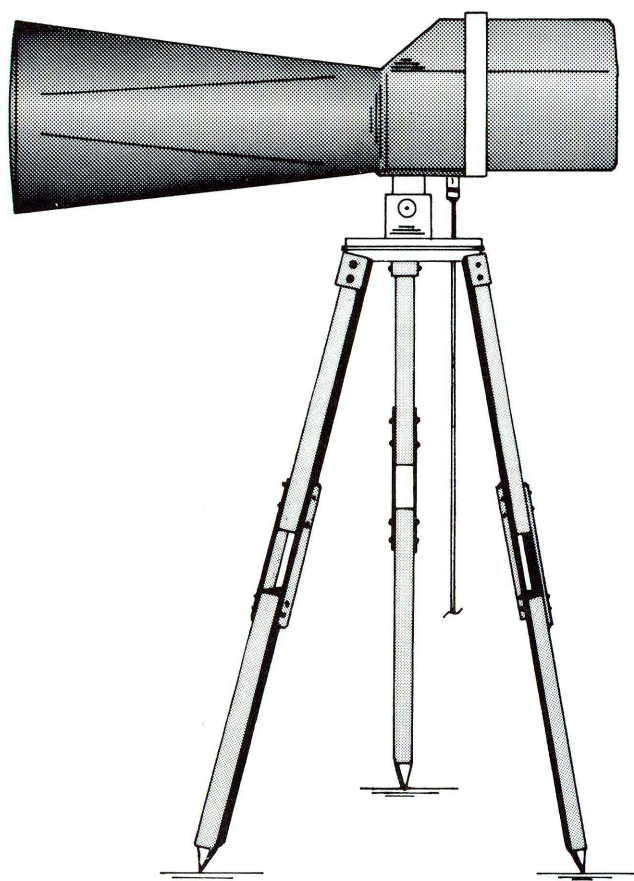

FIGURE 4.2 - RADAR ANTENNA

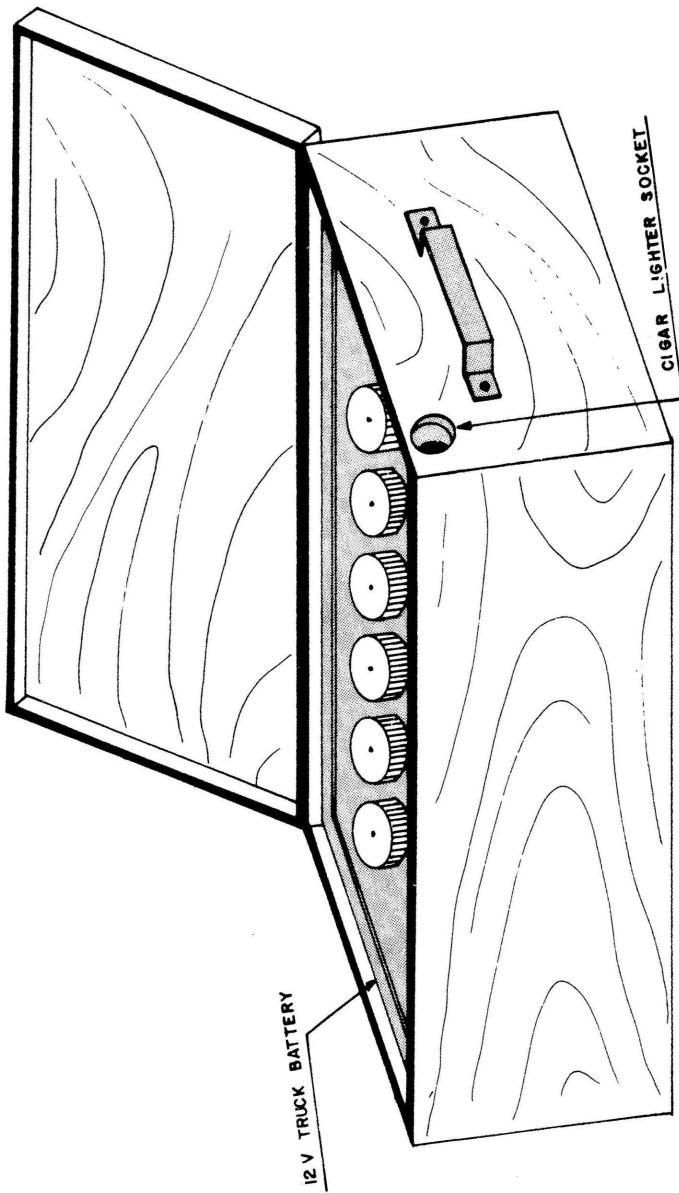

FIGURE 4.3 - RADAR POWER SOURCE



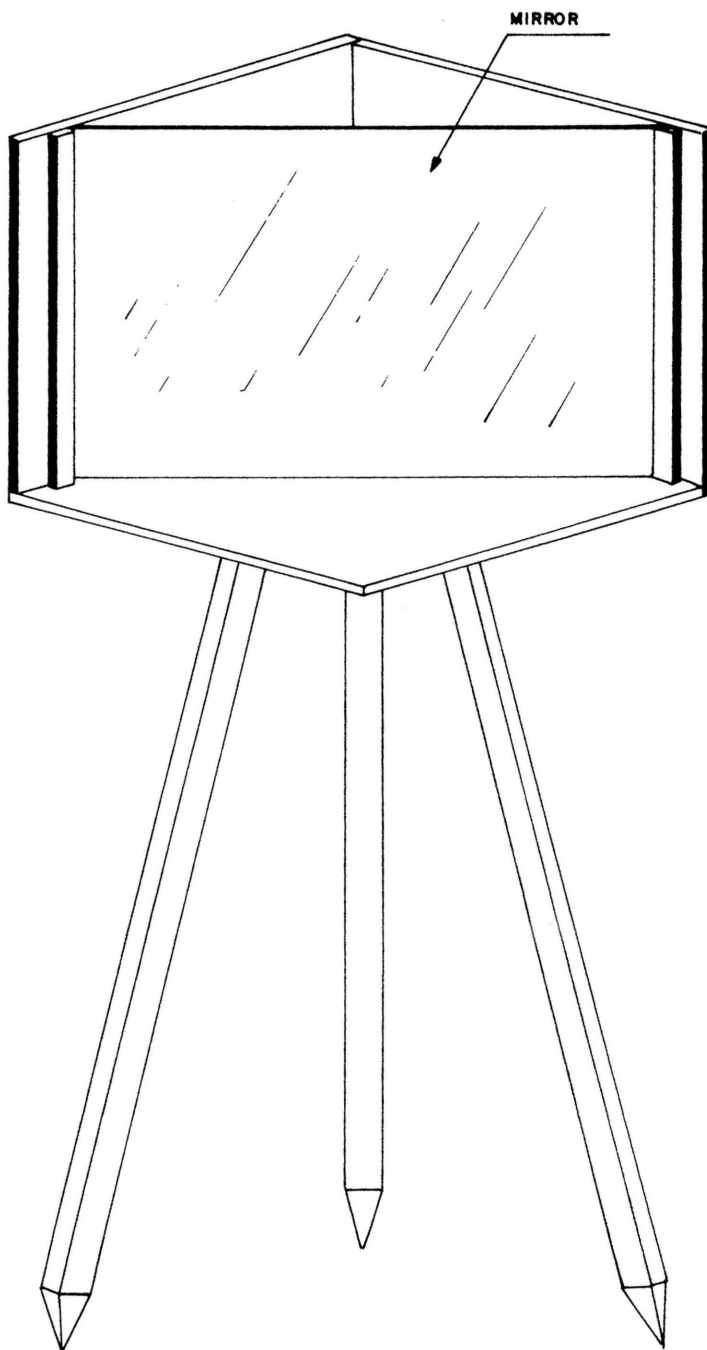

FIGURE 4.4 - MIRROR BOX

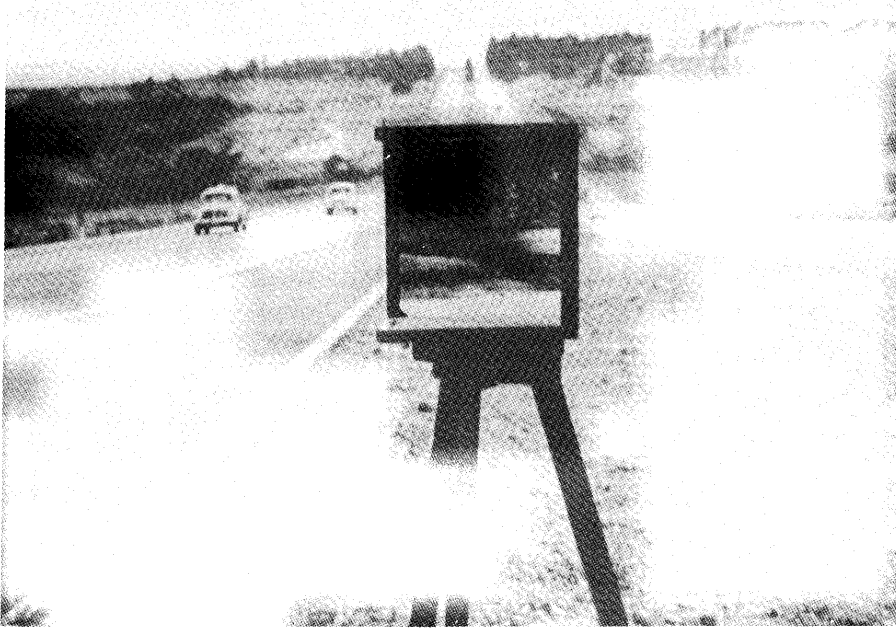

FIGURE 4.5 - MIRROR BOX AT RADAR TEST SITE

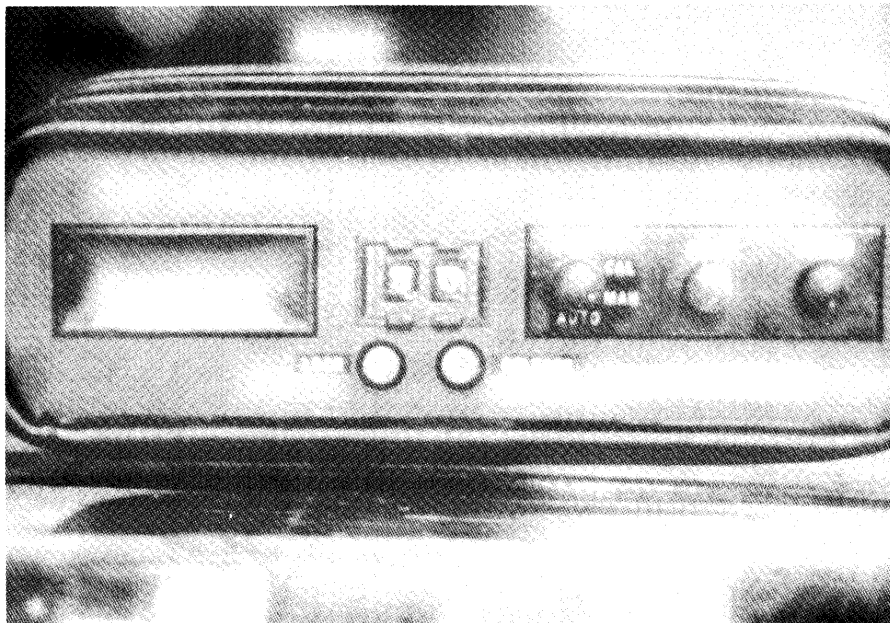

FIGURE 4.6 - RADAR PANEL

another case, the radar was set up on the tangent to a curve and the speed of vehicles as they passed through the curve was recorded. In this experiment the three radar sets were deployed on three different curves.

Only one observer is required to operate a single radar set. However, traffic frequently moves past an observation point too quickly to allow one person to record all required data. In some cases, the recording of additional information, such as time, vehicle class, direction and vehicle load estimate, requires an additional observer.

In general, the radar antenna is aimed down the road in line with the lane of traffic under study. A unit positioned beside a test section is shown in Figure 4.7. The radar automatically detects the vehicle whose speed is being measured and displays the speed in kilometers per hour. Table 4.1 shows a typical radar data field recording form.

#### 4.2.2 *Maintenance*

In the beginning, it was difficult to convince the radar operators to charge the radar set batteries. Most radar failures early in the project were caused by discharged batteries. As time passed, the practice of daily charging of the batteries became firmly established and ceased to be a problem.

Initially the radar set antenna internal power regulator unit was unreliable on all of the radar sets. The regulator failed on every set. It was thought the radar sets were experiencing these failures due to the high ambient temperatures in the field. To test this hypothesis, the antenna cover was painted white to help reflect the heat. Whether or not overheating was the cause, the problem failed to reappear once all of the original regulators were replaced.

With the exception of an antenna which was knocked down and damaged by a passing vehicle, the radar sets performed trouble-free for the last two years of the project.



FIGURE 4.7 - RADAR UNIT AT TEST SITE

**OBSERVAÇÕES DE ACELERAÇÃO E DESACELERAÇÃO**

POPULAÇÃO DOS VEÍCULOS

PICR

FOLHA \_\_\_\_\_ DE \_\_\_\_\_

FICHA DE IDENTIFICAÇÃO 1

NÚMERO DA SEÇÃO 3

DATA 6 

DIA	MÊS	ANO
6		

Nº DA ESTAÇÃO INICIAL 12

DIREÇÃO 13

TIPO DE TESTE  
ACELERAÇÃO (1) 14   
DECELERAÇÃO (2)

ESPAÇAMENTO DAS SUB-ESTAÇÕES (m) 15

VELOCIDADES OBSERVADAS NAS SUB-ESTAÇÕES ( KM / H )				PLACA DO VEÍCULO	CLASS.	CARGA
18	<input type="text"/>	<input type="text"/>	<input type="text"/>	<input type="text"/>	<input type="text"/>	<input type="text"/>
36	<input type="text"/>	<input type="text"/>	<input type="text"/>	<input type="text"/>	<input type="text"/>	<input type="text"/>
54	<input type="text"/>	<input type="text"/>	<input type="text"/>	<input type="text"/>	<input type="text"/>	71
18	<input type="text"/>	<input type="text"/>	<input type="text"/>	<input type="text"/>	<input type="text"/>	<input type="text"/>
36	<input type="text"/>	<input type="text"/>	<input type="text"/>	<input type="text"/>	<input type="text"/>	<input type="text"/>
54	<input type="text"/>	<input type="text"/>	<input type="text"/>	<input type="text"/>	<input type="text"/>	71
18	<input type="text"/>	<input type="text"/>	<input type="text"/>	<input type="text"/>	<input type="text"/>	<input type="text"/>
36	<input type="text"/>	<input type="text"/>	<input type="text"/>	<input type="text"/>	<input type="text"/>	<input type="text"/>
54	<input type="text"/>	<input type="text"/>	<input type="text"/>	<input type="text"/>	<input type="text"/>	71
18	<input type="text"/>	<input type="text"/>	<input type="text"/>	<input type="text"/>	<input type="text"/>	<input type="text"/>
36	<input type="text"/>	<input type="text"/>	<input type="text"/>	<input type="text"/>	<input type="text"/>	<input type="text"/>
54	<input type="text"/>	<input type="text"/>	<input type="text"/>	<input type="text"/>	<input type="text"/>	71
18	<input type="text"/>	<input type="text"/>	<input type="text"/>	<input type="text"/>	<input type="text"/>	<input type="text"/>
36	<input type="text"/>	<input type="text"/>	<input type="text"/>	<input type="text"/>	<input type="text"/>	<input type="text"/>
54	<input type="text"/>	<input type="text"/>	<input type="text"/>	<input type="text"/>	<input type="text"/>	71

OBSERVADOR \_\_\_\_\_

TABLE 4.1 - RADAR DATA RECORDING FORM

#### 4.2.3 *Recommended Maintenance Facilities*

One senior electronics technician  
Volt-ohm meter  
Oscilloscope  
Hand tools

#### 4.3 *CAMERA BOX AND RECORDER BOX*

Both the Camera Box and the Recorder Box served the same purpose. They were used to record accumulated distance travelled at known time intervals to determine vehicle speed changes. Both were constructed by the Instrumentation Group.

##### 4.3.1 *Camera Box*

The camera box consists of a DMI (Linder, "Distance Measuring Instrument - DMI"), a crystal controlled digital stopwatch, and an 8 mm or 16 mm movie camera, all installed in a wooden box. The DMI is supplied distance information by a set of eight magnets fixed to the vehicle's front wheel and a magnet sensor attached near to the magnets on the steering columns. As the front wheel revolves, impulses are generated by the magnet sensor and sent to the DMI where they are summed and scaled to be represented on a six character digital display. The stopwatch was modified to send a HOLD impulse to the DMI and a trigger impulse to the camera at one-second intervals. The DMI was modified to allow its display to freeze during the HOLD impulse so that the resulting photograph of the stopwatch and DMI would have maximum clarity. Remote controls attached to the stopwatch allow the operator to start and stop the system at convenient times. Three camera boxes were constructed. Construction details of the camera box are covered in a Project Instrumentation Memo (Buller, "Camera Boxes"). The camera box layout is shown in Figure 4.8 and illustrated in Figures 4.9 and 4.10.

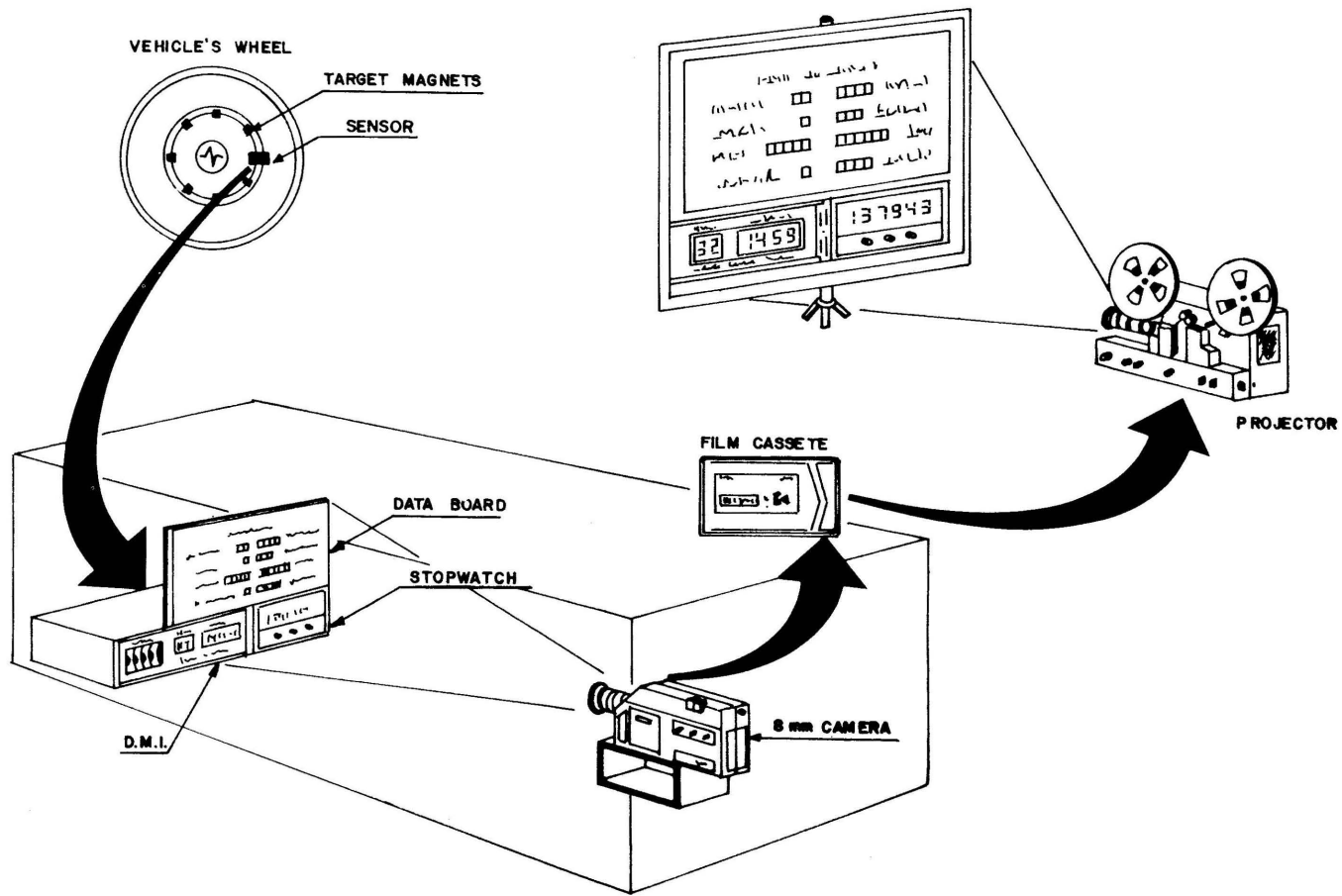

FIGURE 4.8 - CAMERA BOX BLOCK DIAGRAM AND DATA FLOW

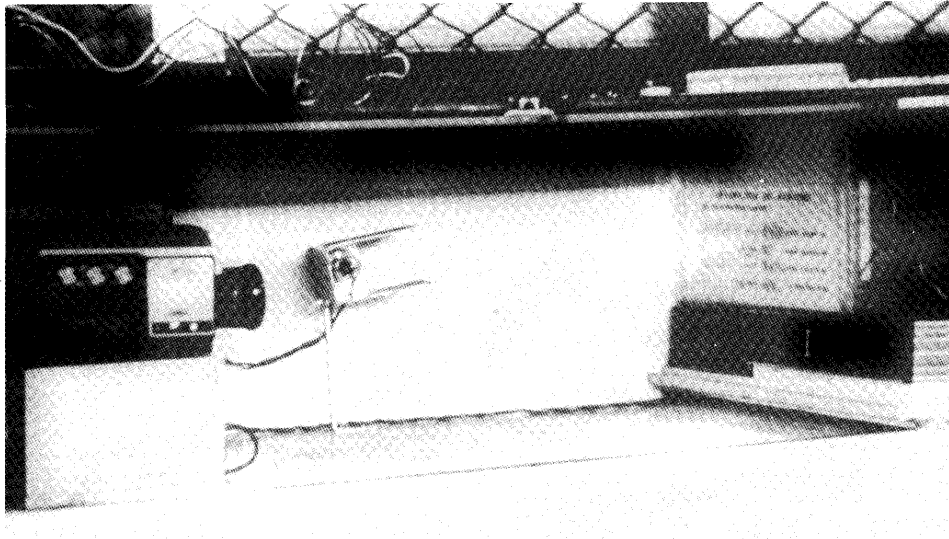

FIGURE 4.9 - CAMERA BOX (8 mm)

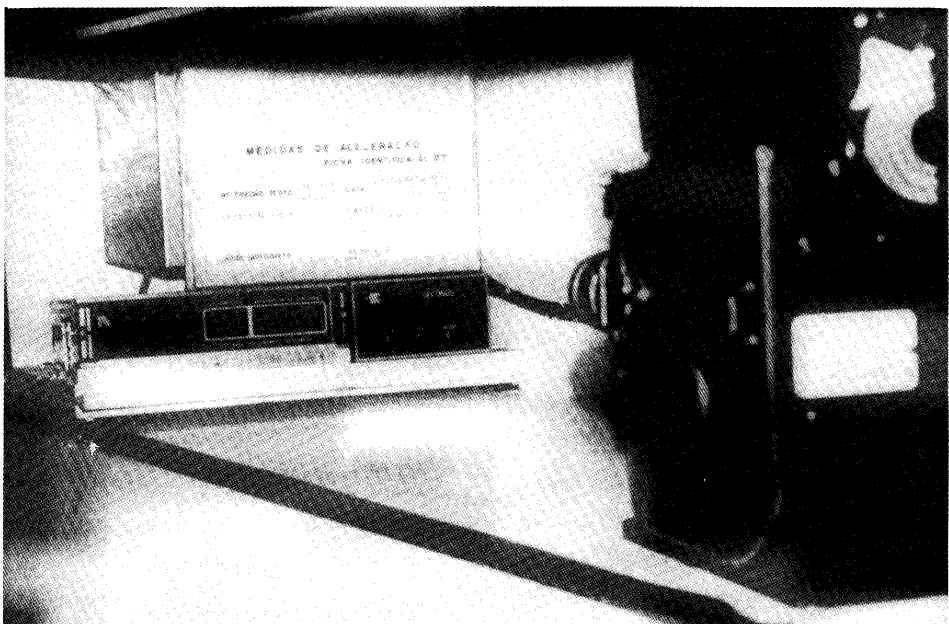

FIGURE 4.10 - CAMERA BOX (16 mm)



#### 4.3.2 *Recorder Box*

The camera box was used for most of the acceleration experiments. Camera boxes suffered the drawback of having all their output on film that required approximately three weeks for developing in local photo shops. It also took a clerk hours to read the time and distance information from the projected film. At the suggestion of the Traffic Group, the Instrumentation Group developed the recorder box as a replacement instrument, the fabrication of which is detailed in a Project Instrumentation Memo (Linder, "Recorder Box").

The recorder box eliminated the filming constraint by recording the DMI distance data on a cassette recorder at 200 millisecond intervals. The cassette was played back onto a printer which printed the DMI data in an easily-readable format. The printing of the cassette takes exactly the same amount of time as required to record the cassette. The recorder box data flow is presented in Figure 4.11.

#### 4.3.3 *Field Operation*

The camera box was located on the bed of a truck or on the rear seat of a passenger vehicle or bus. The operator must turn on the power for the unit and reset the equipment. At the marked initial point of the section, the START switch is pushed and this starts the camera box automatically recording data. At the end of the section, the operator pushes the STOP switch to terminate the recording process.

The use of the recorder box is similar to that of the camera box. The major difference is that the recorder box is much smaller and therefore is kept inside the cab of the trucks and inside passenger vehicles and the bus. Besides the power on/off switch and normal tape recorder controls, there are only two switches for the operator to use. The recorder run/stop switch is shifted on just before the beginning of a section, while the reset switch is held in. At the start of the section the RESET switch is released. The operator waits until the end of the section is reached, then switches the tape recorder off.

The film in the camera box is identified by photographing a data sheet containing information as to the road section, date, load, etc. For the recorder box, that information is handwritten on the outside of the cassette. Further operational details about the camera box

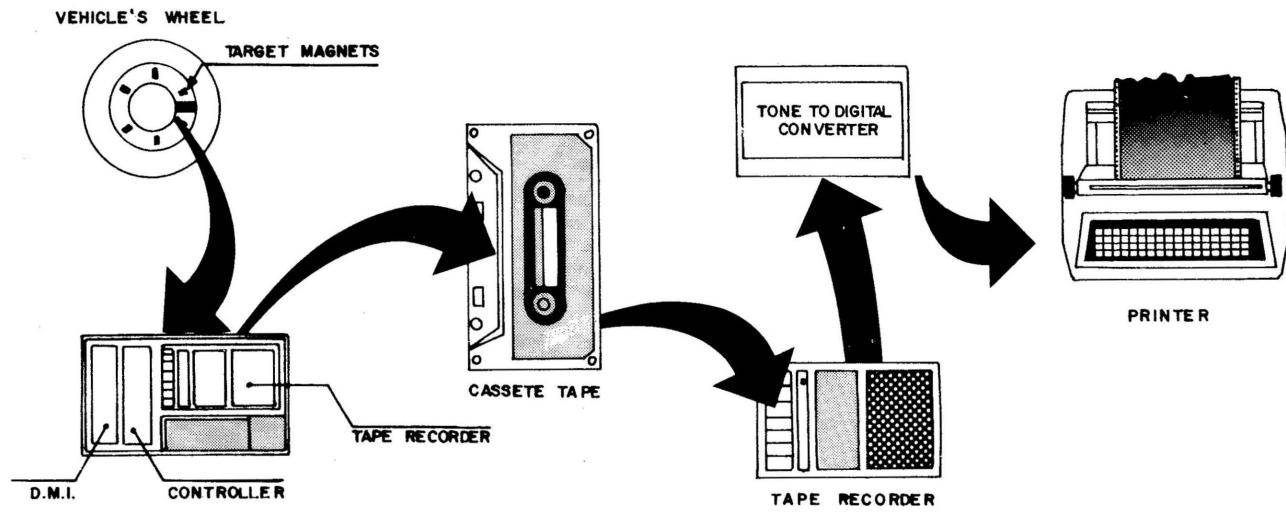

FIGURE 4.11 - RECORDER BOX DATA ROUTE DIAGRAM

and the recorder box are presented in Project Instrumentation Memos (Buller, "Camera Boxes"; Linder, "Recorder Box").

#### 4.3.4 *Maintenance*

The camera box proved difficult to maintain because it was positioned in the bed of trucks that operated on very rough surfaced roads. The camera box with the Bolex 16 mm camera was removed from service permanently. It proved too difficult to maintain because it was more complex than the Minoltas. The other units with 8 mm cameras stood up very well. No camera problems developed despite the hostile environment that they were required to operate in. The DMI and stopwatch were very serviceable with the major problems being broken electrical connections and defective switch units.

The recorder boxes proved reliable during their short service period. Of the three boxes, one was taken out of service because its tape recorder failed and locally available tape recorders were unsuitable as replacements.

#### 4.4 *TACHOGRAPH*

Two types of tachographs were available for project use, one 24-minute type (Figure 4.12) and six 24-hour models of the type shown in Figure 4.13. The 24-minute model is a special research unit manufactured by ARGO Instrument Co., while the other tachographs are manufactured by SANGAMO Electric Co..

The tachograph makes a record of a vehicle's speed profile over a period of time. This record may be used to study vehicles' behavior over long periods of time. Also marked on the record is a distance signature that correlated the speed profile with the geometric features of the road used by the vehicle. A SANGAMO chart is illustrated in Figure 4.14.

##### 4.4.1 *Field Operation*

The 24-hour model tachograph is equipped with a 7-day chart

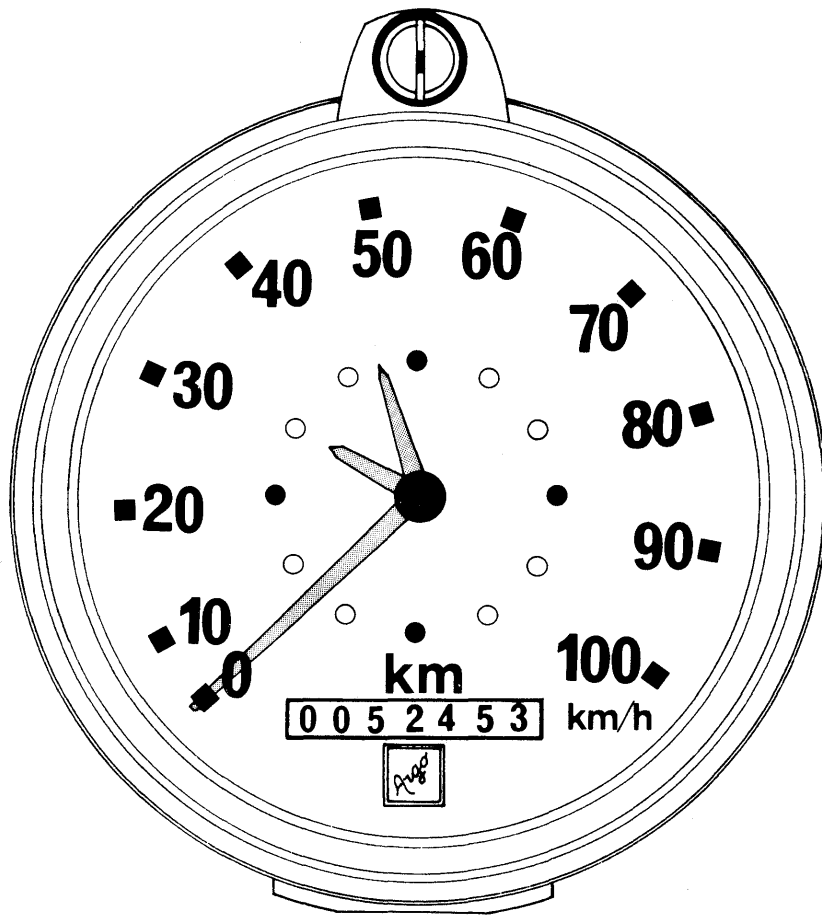

FIGURE 4.12 - ARGO TACHOGRAPH

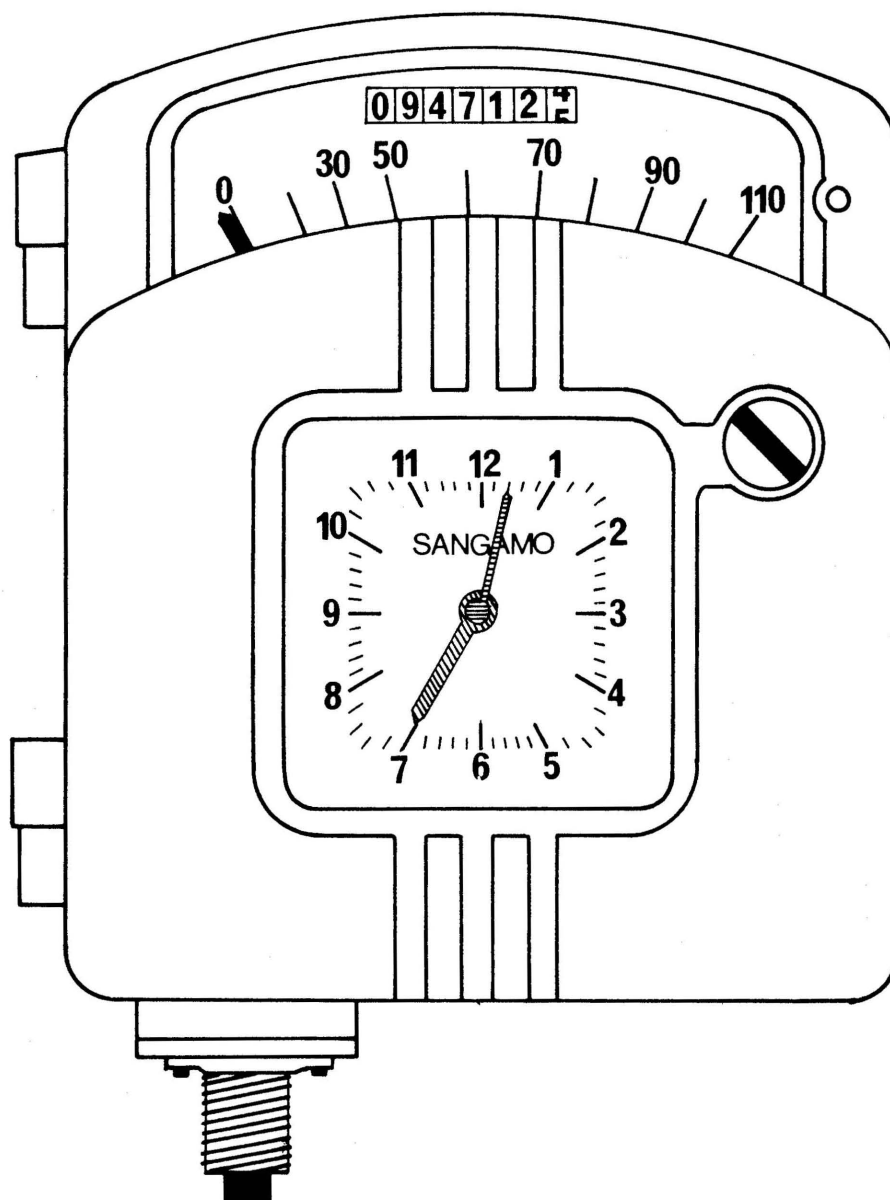

FIGURE 4.13 - SANGAMO TACHOGRAPH

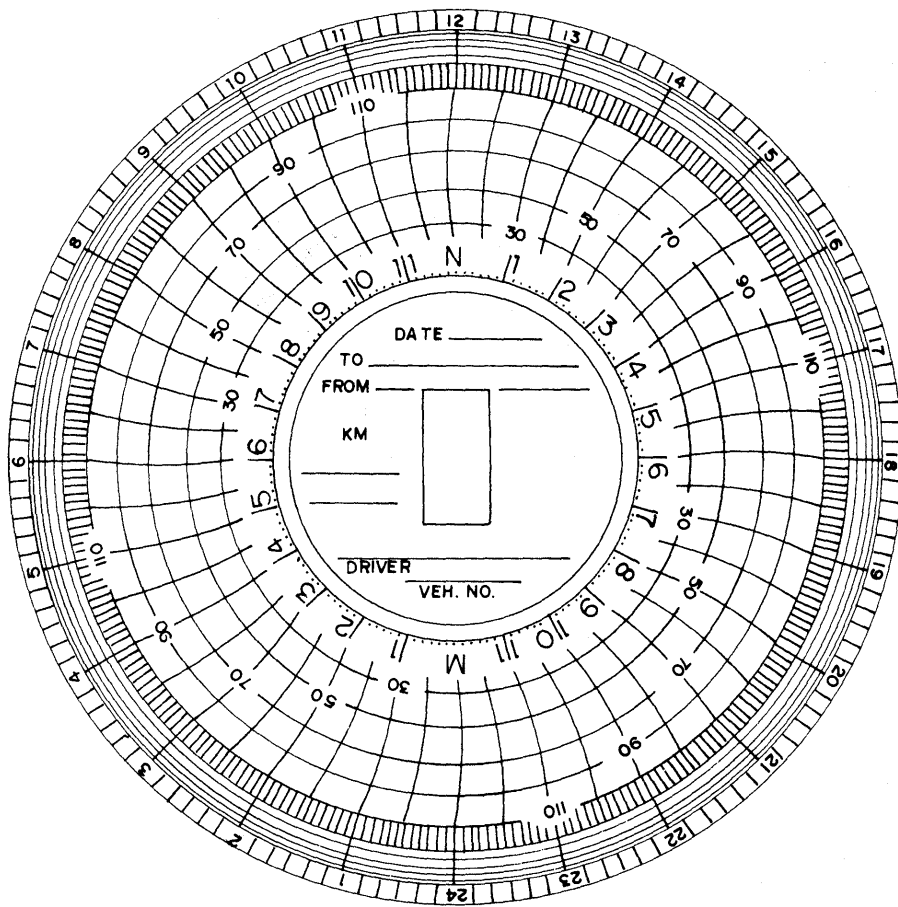

FIGURE 4.14 - SANGAMO TACHOGRAPH CHART

pack. The only requirement is that the chart pack be changed at the end of each 7-day period. The driver needs to take no action concerning the tachograph's operation.

The ARGO tachograph is equipped with a button-activated event pen that may be used to mark particular points on the route being used. Its chart makes one complete revolution every 24 minutes and it is necessary to wind the watch mechanism. Otherwise it is the same as the 24-hour model.

#### 4.4.2 *Maintenance*

Maintenance was not a problem for the tachographs. Some repair was required when an operator used them incorrectly. The 24-minute tachograph created a problem because it had a hand-wound clock. The drivers frequently forgot to wind it. Consequently, the speed profile and distance pens would eventually wear a hole in the chart paper. The pen would stick in the hole and the speedometer needle of the tachograph could not move properly.

#### 4.4.3 *Maintenance Facilities*

A tachograph distributor's speedometer repair shop is recommended for maintenance and repairs.

### 4.5 *THE PHOTO-ELECTRIC LIGHT INTENSITY DETECTOR (PELID)*

This equipment was designed and constructed by the Measurement Instrument Group to quantify the change in visibility from dust raised by a vehicle travelling over an unpaved road. It consists of a light detector/amplifier, a target board and an indicator/metronome unit. The unit is shown in Figure 4.15 and schematically as set up in the field in Figure 4.16.

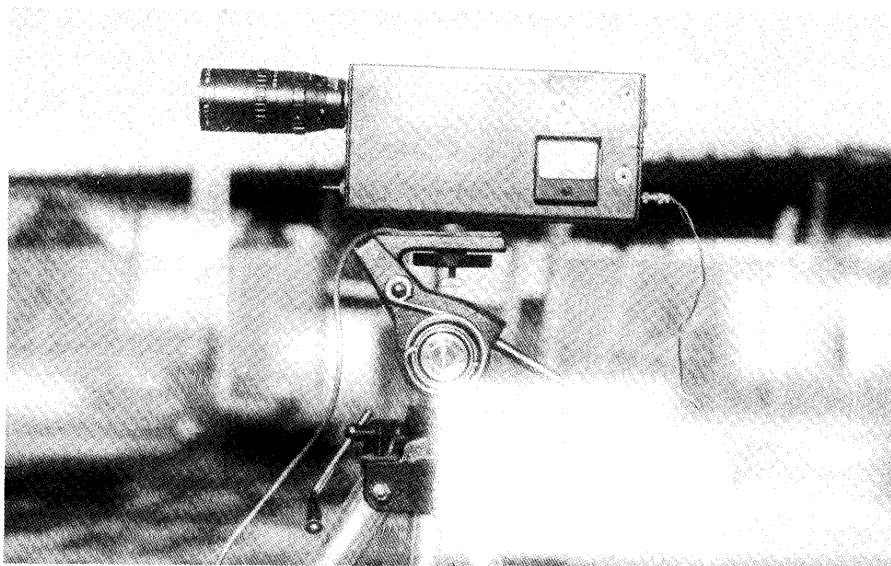

FIGURE 4.15 - PELID MOUNTED ON A TRIPOD



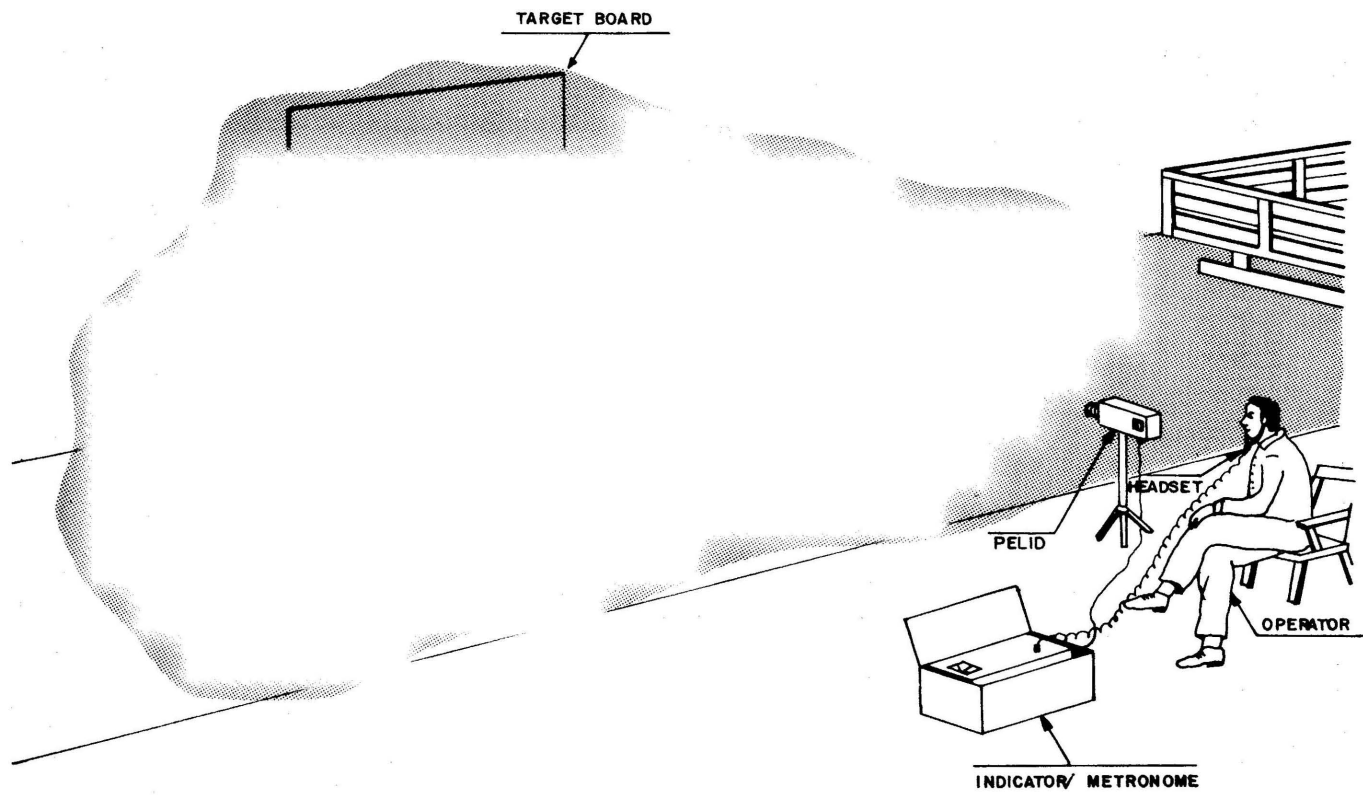

FIGURE 4.16 - PELID IN THE FIELD

#### 4.5.1 *Operating Principle*

The target board, a 1.5 square meter white board, is set-up on one side of an unpaved road and the other two units on the far side of the road, directly opposite the target. The light reflected from the target is collected by a telephoto lens and focused onto a photo-cell in the detector circuit, which also contains a moving coil meter to permit setting the amount of ambient light received by the photo-cell to a standard value for each measurement. This is accomplished by changing the lens aperture setting and, in bright sunlight, by means of a blue filter mounted in front of the lens.

When a vehicle passes and raises dust, the amount of light seen by the photo-cell is reduced and an electrical signal proportional to the reduction is produced in the detector circuit. This signal is amplified and the portion from the vehicle itself is backed-off, so that the much smaller portion due to dust can be adequately displayed on the read-out meter.

Readings are taken at discrete intervals, indicated to the operator via a head-set from an electronic metronome. The intervals may be varied to suit the ambient conditions of the day to ensure that a sufficient number of readings is obtained before the dust settles or is dispersed by wind. Details on the PELID are presented in a Project Instrumentation Memo (Buller, "Photo Electric Light Intensity Detector - PELID").

#### 4.5.2 *Field Operation*

The target board is set up and the detector mounted on a tripod on the opposite side of the road. The operator then focuses the lens on the target by means of the through-the-lens focusing system to reduce unwanted light to a minimum. The detector light level is set by adjusting the lens aperture, the correct level being indicated by a datum point on the meter. The read-out meter is then set to show full-scale deflection by means of a variable resistor and, when a vehicle passes, the reduced readings on the read-out meter are recorded at discrete intervals until the air between the target and lens is clear.

#### 4.5.3 Maintenance

This mainly consists of keeping the lens and target board clean.

The original 9 volt batteries were troublesome because of their small capacity and different rates of discharge. This caused difficulty in balancing the back-off voltage. To overcome this, two heavy-duty 12 volt batteries were used externally and connected by means of a 4-core cable directly into the detector case.

This equipment is impossible to use on a day with numerous small clouds since the ambient light value is constantly changing and therefore the detector circuit cannot be set up.

#### 4.6 TRAFFIC FLOW DATA LOGGER

The Traffic Flow Data Logger (TFDL) was designed and built by the Measurement Instrument Group to capture on cassette tape the following information:

- The time of day that a specific vehicle passes a test site.
- The period of time required for a specific vehicle's axles to travel one meter.
- The direction of travel of a specific vehicle.
- A photograph of the specific vehicle.

The purpose of the TFDL is to gather data to determine vehicle speed, headway, density, class, and passing maneuvers, all to be used to calibrate the Model for Simulating Traffic (MST) (See Kaesehagen and Moser, and Volume 10 of this Report).

The equipment was originally designed to include a data entry terminal for the operator, in the form of a hand-held keyboard connected to the control box via a cable. The operator entered coded numerical data into the data record of each vehicle for identifying, classifying and estimating the load of the passing vehicle. After months of training the operators could not master this procedure. This, coupled with problems associated with maintaining the keyboard units, prompted revision of the equipment, excluding the keyboard and relying solely on the photographic record for vehicle identification.

The equipment was originally designed to include a magnetic vehicle sensor. This device would have isolated each vehicle record. The sensor proved unreliable, so other techniques were tried. Among these were a hastily-constructed timer whose time-out period was related to vehicle speed. This unit would not stand up to field temperatures. The last attempt involved an operator using a push button to identify each vehicle. The operators again could not be trained to reliably operate this equipment. Vehicles were finally recognized through a computer analysis, where the logic was based on the fact that the axles of each vehicle travel at the same speed and that there is a limited range of feasible axle spacings.

#### 4.6.1 *Operating Principle*

The traffic flow data logger is a microprocessor-controlled device containing a precision timer, a clock giving the time-of-day, an interface to a cassette tape recorder and switch closure sensors. Pneumatic road tubes are laid out on the road at each of the six sites. The road tubes are interfaced to the traffic flow data logger via traffic counter road tube detectors which issue a contact closure to the processor unit when a vehicle's axle passes over the road tube. At the same time, a camera at each site is triggered for vehicle identification. The processor is programmed to read and record the precision timer reading and time-of-day when the vehicle passes over a road tube. The construction and design details of the traffic flow data logger are presented in a Project Instrumentation Memo (Linder, "Traffic Flow Data Logger", Memo No. 012/78).

#### 4.6.2 *Field Operation*

The field crew installed road tubes on premarked and prepared sites, connected all the cables and tubes to the unit and simultaneously started all three traffic flow data loggers to synchronize their time-of-day clocks.

Every 15 minutes, the crew exposed a data board containing the time of day to the camera to aid in locating a particular time segment on the film, and also for correlating the cassette data record to the film record.

The crew checked the tape recorder periodically to see if its cassette needed changing. A technician constantly patrolled the six sites, checking for equipment malfunctions and for low battery voltages. A typical field layout is depicted in Figure 4.17 and a description of field operations is given in a Project Instrumentation Operational Memo (Linder, "Traffic Flow Data Logger", Memo No. 013/78).

#### 4.6.3 *Maintenance*

The maintenance of the TFDL was a major problem. The road tubes deteriorated rapidly under heavy traffic conditions, especially on coarse textured roads. The main batteries required daily charging and for this reason two sets of batteries were on hand, one being charged and one in use. The equipment did not function well at high ambient temperatures and occasionally stopped working.

#### 4.6.4 *Recommended Maintenance Facilities*

- One electronics engineer
- One senior electronics technician
- Volt-ohm meter
- Oscilloscope
- Hand tools.

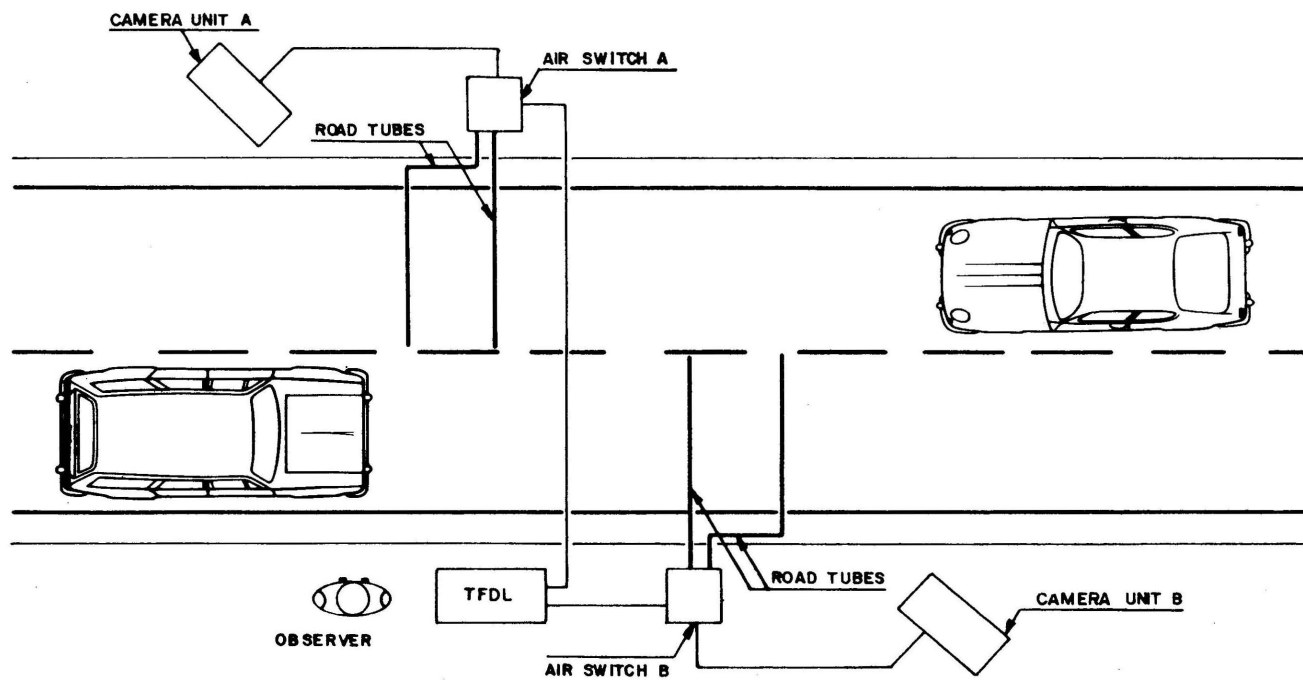

FIGURE 4.17 - FIELD LAYOUT FOR TFDL

CHAPTER 5  
PAVEMENT DEFLECTION EQUIPMENT





## 5.1 INTRODUCTION

Two deflection measurement devices were used on this project to aid in determining pavement strength and to predict pavement performance. They were the Benkelman Beam and the Dynaflect.

The Benkelman Beam is used manually, resulting in a slow collection of deflection data. It does allow deflection measurements to be taken under a great variety of loading conditions. The Benkelman Beam is widely used throughout Brazil.

The Dynaflect is a rapid data gathering system which exerts its own load on the pavement and automatically records the deflection data on a teletype machine. The load exerted is relatively small, being 1000 pounds.

## 5.2 BENKELMAN BEAM

The Benkelman Beam is a long lever. One end is placed in contact with the pavement surface between the test vehicle's tandem wheels. The other end of the beam is fitted with a dial gauge to measure the displacement of that end when the pavement deflects due to the load. The reading on the dial gauge is then multiplied by the ratio of lever arms to obtain the actual deflection of the road surface. Figures 5.1 and 5.2 illustrate the Benkelman Beam.

A detailed description of the use of the Benkelman Beam and the Dynaflect is covered in a Project Technical Memo (Visser, "Pavement Performance and Maintenance Experimental Sections").

### 5.2.1 Maintenance

The major source of beam failure was rough handling by the operating crew. The original bearings were replaced with sealed, precision, industrial bearings after the original cone-and-cup bearings fell apart. The beams are fitted with electric buzzers that vibrate the beams to reduce bearing static friction. The buzzers needed periodic attention to keep them operational.

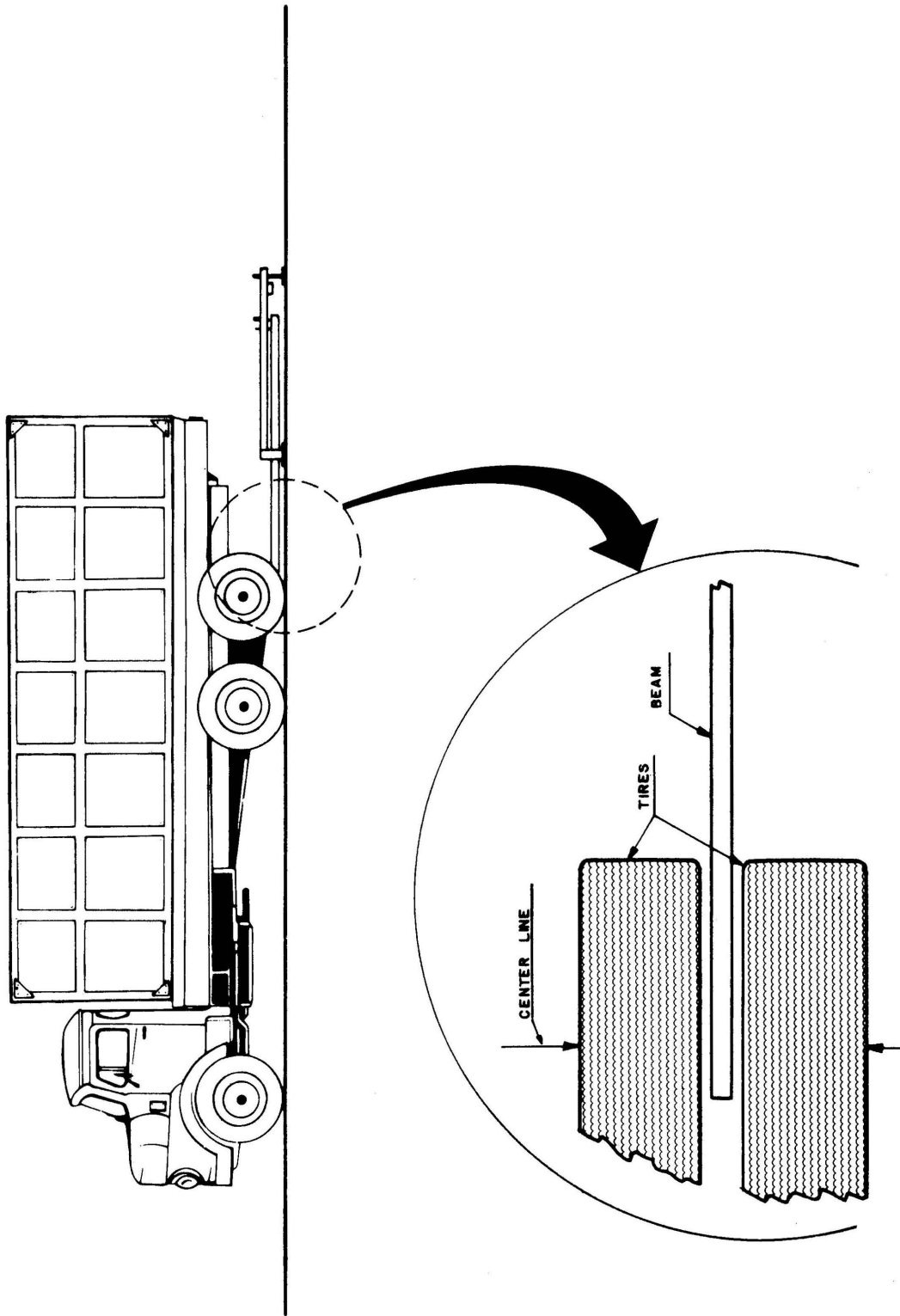

FIGURE 5.1 - BENKELMAN BEAM



FIGURE 5.2 - BENKELMAN BEAMS BEING USED TO MEASURE PAVEMENT DEFLECTIONS

Each beam was fitted with a precision dial gauge. The gauges were sensitive to rough handling and consequently needed frequent repairs.

### 5.3 DYNAFLECT

The Dynaflect consists of a dynamic force generator mounted on a small two-wheel trailer, a control unit and teletype, a sensor assembly, and a sensor calibration unit. It is manufactured by SIE, Inc.

The system is designed to operate behind a vehicle that has a rigid trailer hitch and a 12 volt battery system. After initial calibration, successive measurements can be made at different positions by a single operator/driver without leaving the towing vehicle. The Dynaflect is depicted in Figure 5.3 at a test location in test position. Its specifications are outlined in Table 5.1.

#### 5.3.1 *Operating Principle*

The Dynaflect applies a repeated force of 1000 pounds (peak-to-peak) to the surface of the pavement through two rigid wheels. The resulting periodic deflection of the surface is sensed by an array of 5 geophones, spaced 12 inches apart in a line perpendicular to the center of the trailer's axle as shown in Figure 5.4. The signals from the geophones are filtered, scaled and then converted to digital form displayed on the face of the control unit, Figure 5.5. The operator may either copy the digitized sensor data on a recording form or on the teletype in the form of a punched paper tape and printed paper.

#### 5.3.2 *Field Operation*

The Dynaflect crew consisted of a driver and an observer, although the operation is simple enough to allow the driver to perform both functions. Because of the required slow towing speed (less than 10 km/h) while in operation) and the frequent stops, it is advisable to provide highway police or other road guards, to prevent accidents.

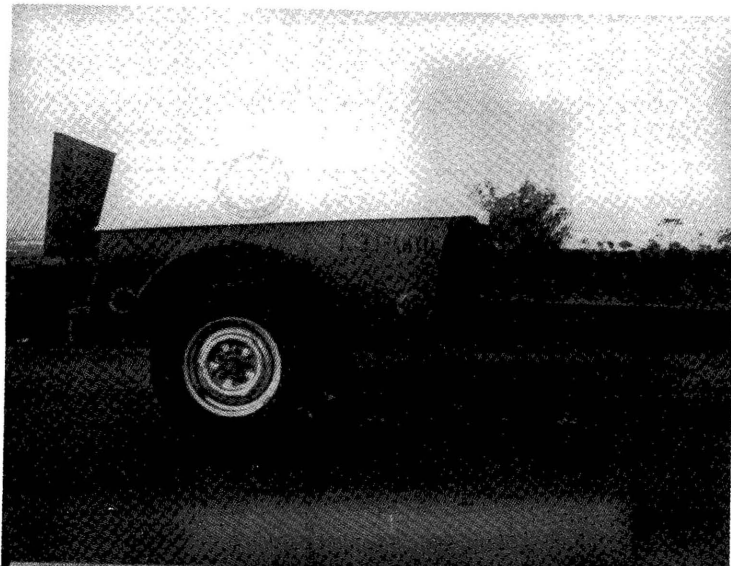

FIGURE 5.3 - DYNAFLECT IN MEASUREMENT POSITION ON A TEST SECTION



FIGURE 5.4 - DYNAFLECT SENSORS IN POSITION AND READY FOR TESTING

TABLE 5.1 - SPECIFICATIONS FOR DYNAFLECT

POWER:	12 VDC, 100 amp (starting current) 8 amp (running current)
TOWING SPEED:	
Pneumatic Tires	Legal Speed Limit
Rigid Wheels	10 km/h maximum on smooth surface, proportionally lower speeds for irregular surfaces
TRAILER WEIGHT:	
Static	1600 lbs
Dynamic	Varies sinusoidally from 2100 lbs to 1100 lbs at 8 Hz
TIRE SIZE:	7.50 x 14
TRAILER DIMENSIONS:	69" wide 46" high 124" long
TREAD WIDTH:	59 1/2"

Source: manufacturer, SIE, INC.

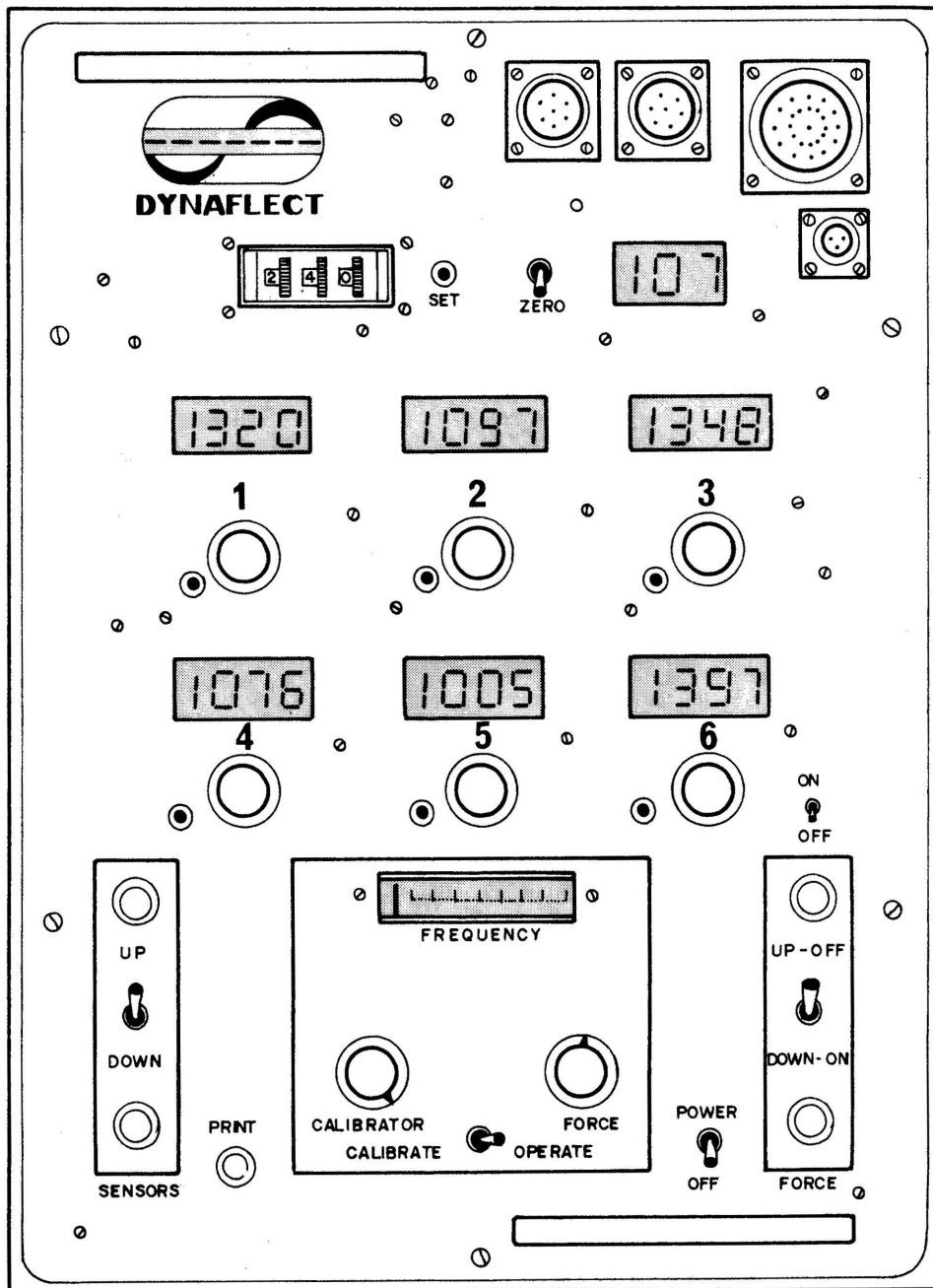

FIGURE 5.5 - DYNAFLECT CONTROL UNIT

The operating steps include the following:

1. The geophone/control unit is calibrated on site by the crew.
2. The force wheels are lowered into position once the Dynaflect is at its measurement site.
3. The operator lowers the geophone array, records the deflection data, then raises the geophone array.
4. The driver then moves up the road at a slow speed of 10 km/h (short distances only) to the next measurement site.
5. When all data are taken at a particular section the force wheels are raised and the equipment and crew proceed to the next section at normal highway speed.
6. The copied data is returned to the office for analysis.

### 5.3.3 *Recommended Maintenance Facilities*

Electronics Engineer  
 Electronics Technician  
 Mechanic  
 Volt-ohm meter  
 Oscilloscope  
 Adjustable strobe lamp  
 Normal hand tools

### 5.3.4 *Major Sources of Maintenance Problems*

The Dynaflect was hauled between test sites at excessive speeds, which was the major reason for maintenance and repair. The most serious problem involved the trailer suspension spring, which broke a number of times. This occurred when the trailer hit a hole in the road at high speeds, and happened on three separate occasions, requiring replacement of the springs. The Dynaflect manufacturer did not anticipate spring breakage and provided no means for spring replacement short of cutting the axle in half, sliding on new springs and then soldering the axle back together.

Providing sufficient electrical power to lift the trailer onto its rigid measurement wheels was an early problem. An extra heavy



duty (100 amp, 12 volt) alternator was fitted on the towing vehicle's engine and extra heavy cables were run from the battery to the trailer. It was found that the trailer control unit needed a full 12 volts DC to function, which means that the alternator, battery, and cables must be in top condition, requiring service at frequent intervals.

Electronic problems developed in the main control unit but were remedied without excessive down-time. Also, the force generator position sensor switches required replacement twice.

In early trials, the operators frequently forgot to disconnect the trailer-to-towing-vehicle electric cables during transport, which resulted in the wires being ripped out of their sockets.

The Dynaflect was hit from behind once by another vehicle which bent the trailer towing arm. It was restraightened and strengthened.

The Dynaflect was in use constantly and subjected to considerable travel. It proved to be a valuable tool in terms of its durability and productivity. However, the data collected proved difficult to use in practice. Recent analysis (Queiroz, "Performance Prediction Models for Pavement Managment in Brazil") indicate that the data collected with the Benkelman Beam correlate better than the data collected by the Dynaflect with the behavior of Brazilian pavements. For a comparison between the two methods used for measuring pavement deflection in the PICR see Queiroz, *et al.*, "Resultados de Deflexões com Vigas Benkelman", p. 12.



CHAPTER 6  
FUEL CONSUMPTION  
MEASUREMENT EQUIPMENT



## 6.1 INTRODUCTION

Two types of fuel meters were used to make measurements of fuel consumed over a specified distance to provide data for the various fuel consumption experiments conducted by the Road User Costs and Traffic Experiments Groups (GEIPOT, "Report II: Midterm Report - Preliminary Results and Analysis"). The two types are called the "Reservoir", used over a short distance (one kilometer) and the "Volumetric", used over a long distance (ten kilometers). The "Reservoir" type could not be used over long distances since its capacity was too small, and a calibrated refill system, although feasible, was considered too cumbersome for some project vehicles.

A means of recording time and distance simultaneously was needed to determine fuel consumption during acceleration. A Camera Box was developed for this purpose (See section 4.6.1). It includes a movie camera, used to film the digital displays of an electronic distance measuring instrument, and an electronic stopwatch. Subsequently a Recorder Box was developed to fulfill this function (See section 4.6.2), the important difference being that data reduction is much easier from magnetic tape than from film.

A split-second hand mechanical stopwatch was used in conjunction with a distance measuring instrument and a reservoir fuel meter, to obtain average vehicle speed during the fuel consumption measurements.

Data acquired with these instruments were entered on the appropriate data collection form, shown in Table 6.1. The particular form shown was used with a "Reservoir" type fuel meter.

## 6.2 RESERVOIR FUEL METER

This fuel meter is a modified version of the ones used in the Kenya research (Zaniewski, "Fuel Meters") and was chosen for use in Brazil because of its simplicity and accuracy. It was not, however, as easily constructed as anticipated. Several models were tried, including one designed by a consultant, before the final manifold version was chosen.

OBSERVAÇÕES DE CONSUMO DE COMBUSTÍVEL

PICR

FOLHA \_\_\_\_\_ DE \_\_\_\_\_

FICHA DE IDENTIFICAÇÃO

1

SECÃO Nº

3

DIA MÊS ANO

DATA 6

VEÍCULO-TESTE Nº

12

CARGA (KG)

15

Nº DO MOTORISTA

20

REGULADO: SIM (1) NÃO (2)

22

INÍCIO DA CORRIDA - POSTO Nº

23

TÉRMINO DA CORRIDA - POSTO Nº

24

	LEITURA DO MEDIDOR DE COMBUSTÍVEL (ml)	VELOCIDADE ADOTADA (KM/H)	MARCHA USADA	TEMPOS DE PERCURSO				EXT. TRECHO CADA CILINDRO	
				AOS 50 %		AOS 100 %			
				MIN	SEG	MIN	SEG		
25	<input type="text"/>	<input type="text"/>	<input type="text"/>	<input type="text"/>	<input type="text"/>	<input type="text"/>	<input type="text"/>	<input type="text"/>	
43	<input type="text"/>	<input type="text"/>	<input type="text"/>	<input type="text"/>	<input type="text"/>	<input type="text"/>	<input type="text"/>	<input type="text"/>	
61	<input type="text"/>	<input type="text"/>	<input type="text"/>	<input type="text"/>	<input type="text"/>	<input type="text"/>	<input type="text"/>	<input type="text"/>	80
25	<input type="text"/>	<input type="text"/>	<input type="text"/>	<input type="text"/>	<input type="text"/>	<input type="text"/>	<input type="text"/>	<input type="text"/>	
43	<input type="text"/>	<input type="text"/>	<input type="text"/>	<input type="text"/>	<input type="text"/>	<input type="text"/>	<input type="text"/>	<input type="text"/>	
61	<input type="text"/>	<input type="text"/>	<input type="text"/>	<input type="text"/>	<input type="text"/>	<input type="text"/>	<input type="text"/>	<input type="text"/>	80
25	<input type="text"/>	<input type="text"/>	<input type="text"/>	<input type="text"/>	<input type="text"/>	<input type="text"/>	<input type="text"/>	<input type="text"/>	
43	<input type="text"/>	<input type="text"/>	<input type="text"/>	<input type="text"/>	<input type="text"/>	<input type="text"/>	<input type="text"/>	<input type="text"/>	
61	<input type="text"/>	<input type="text"/>	<input type="text"/>	<input type="text"/>	<input type="text"/>	<input type="text"/>	<input type="text"/>	<input type="text"/>	80
25	<input type="text"/>	<input type="text"/>	<input type="text"/>	<input type="text"/>	<input type="text"/>	<input type="text"/>	<input type="text"/>	<input type="text"/>	
43	<input type="text"/>	<input type="text"/>	<input type="text"/>	<input type="text"/>	<input type="text"/>	<input type="text"/>	<input type="text"/>	<input type="text"/>	
61	<input type="text"/>	<input type="text"/>	<input type="text"/>	<input type="text"/>	<input type="text"/>	<input type="text"/>	<input type="text"/>	<input type="text"/>	80
25	<input type="text"/>	<input type="text"/>	<input type="text"/>	<input type="text"/>	<input type="text"/>	<input type="text"/>	<input type="text"/>	<input type="text"/>	
43	<input type="text"/>	<input type="text"/>	<input type="text"/>	<input type="text"/>	<input type="text"/>	<input type="text"/>	<input type="text"/>	<input type="text"/>	
61	<input type="text"/>	<input type="text"/>	<input type="text"/>	<input type="text"/>	<input type="text"/>	<input type="text"/>	<input type="text"/>	<input type="text"/>	80

OBSERVADOR \_\_\_\_\_

TABLE 6.1 - FUEL CONSUMPTION DATA RECORDING FORM

Any gasoline resistant material may be used as a cylinder. Glass was rejected for safety reasons. Nalgene laboratory graduated cylinders were finally selected as fuel reservoirs. Nalgene behaves well for about two years of constant exposure to gasoline and strong sunlight. Then the cylinder warps and becomes discolored, making the cylinder scale useless. Because Nalgene is nearly chemically inert, no type of adhesive or sealant could be found to seal connections to the cylinders. This caused a major problem with leaks from fuel line connections and in twin-cylinder models at the level-equalizing tube connections. The problem was eventually resolved by constructing threaded aluminum manifolds that the cylinders could be screwed into.

This type of fuel meter consists of a reservoir cylinder or pair of cylinders, sealed top and bottom with a manifold, a scale for reading the fuel level in the cylinders, an exact means of filling the cylinders with fuel, and a means of selecting the engine fuel supply, from either the vehicle fuel tank or the reservoir cylinder. In the case of a diesel vehicle, the return fuel line is switched on simultaneously with the fuel supply line, by means of a pair of conjugated valves, so the unburned fuel is returned to the source, as shown schematically in Figure 6.1. The engine block includes the vehicle fuel components such as the fuel pump, filter and carburetor. The gasoline system is shown by the solid lines while the dashed lines show the additional connections to convert to diesel.

A typical diesel system panel layout is shown in Figure 6.2. Full information concerning its development and constructional details, including the method used to conjugate two valves and machining required for the twin-cylinder manifolds is covered in two earlier Project Documents (Zaniewski, "Fuel Meters"; Buller, "Reservoir Fuel Meters").

Cylinders of individual fuel meters were scaled to the vehicle type, so each vehicle would have the smallest possible diameter cylinder to maximize the resolution. Fuel meters were built to study consumption over a range of vehicles from a 1300 cc Volkswagen up to a 285 HP Scania truck. At typical fuel meter used in test vehicles is shown in Figure 6.3.

The cylinder's scale was used for the single cylinder instruments. It was difficult to read the fuel level of two cylinder meters when the vehicle was transversely inclined. To overcome this, a small diameter sight-tube was fitted between the two cylinders and an accurate scale made and set against the sight-tube. Detailed information

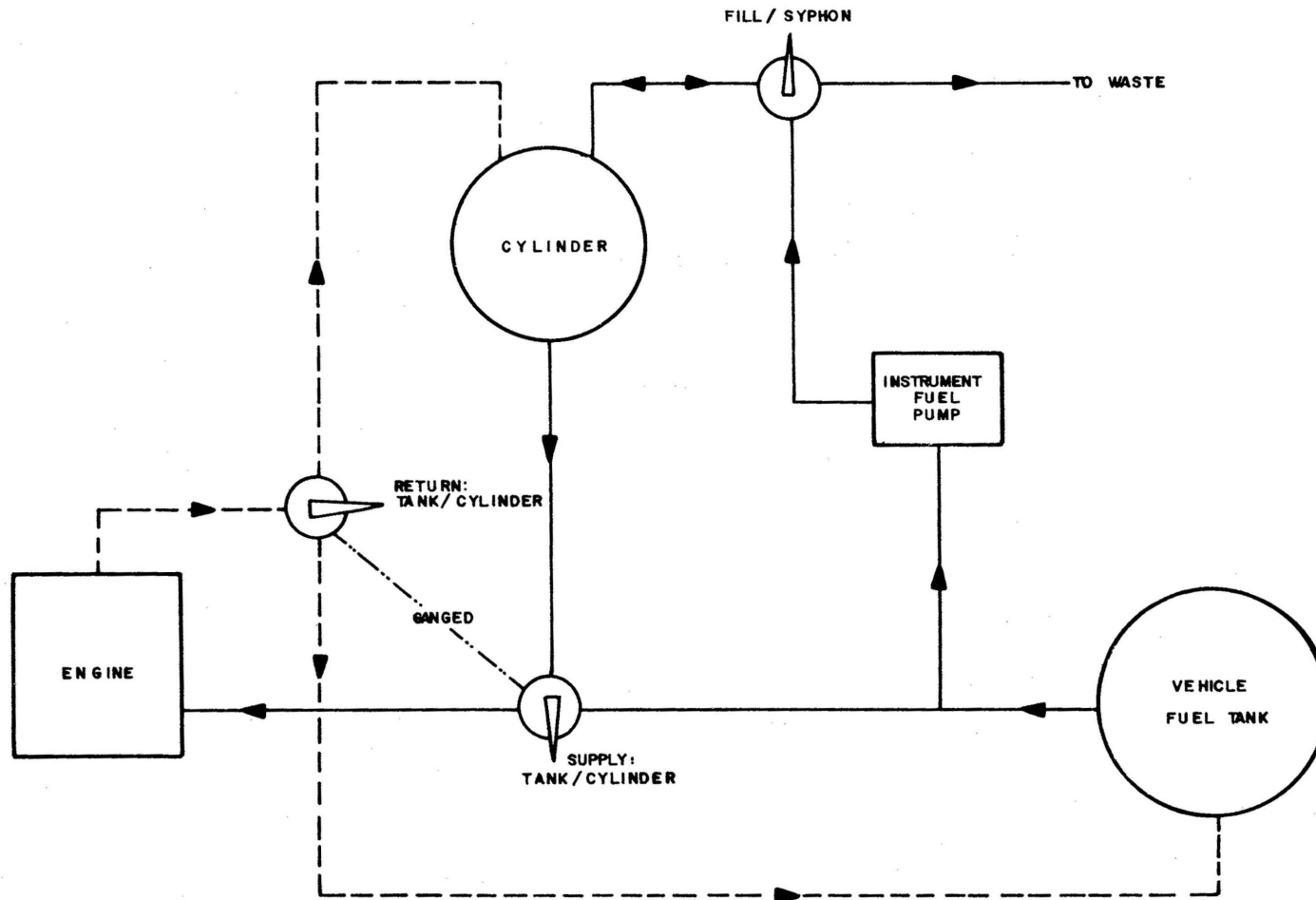

FIGURE 6.1 - SYSTEM SCHEMATIC



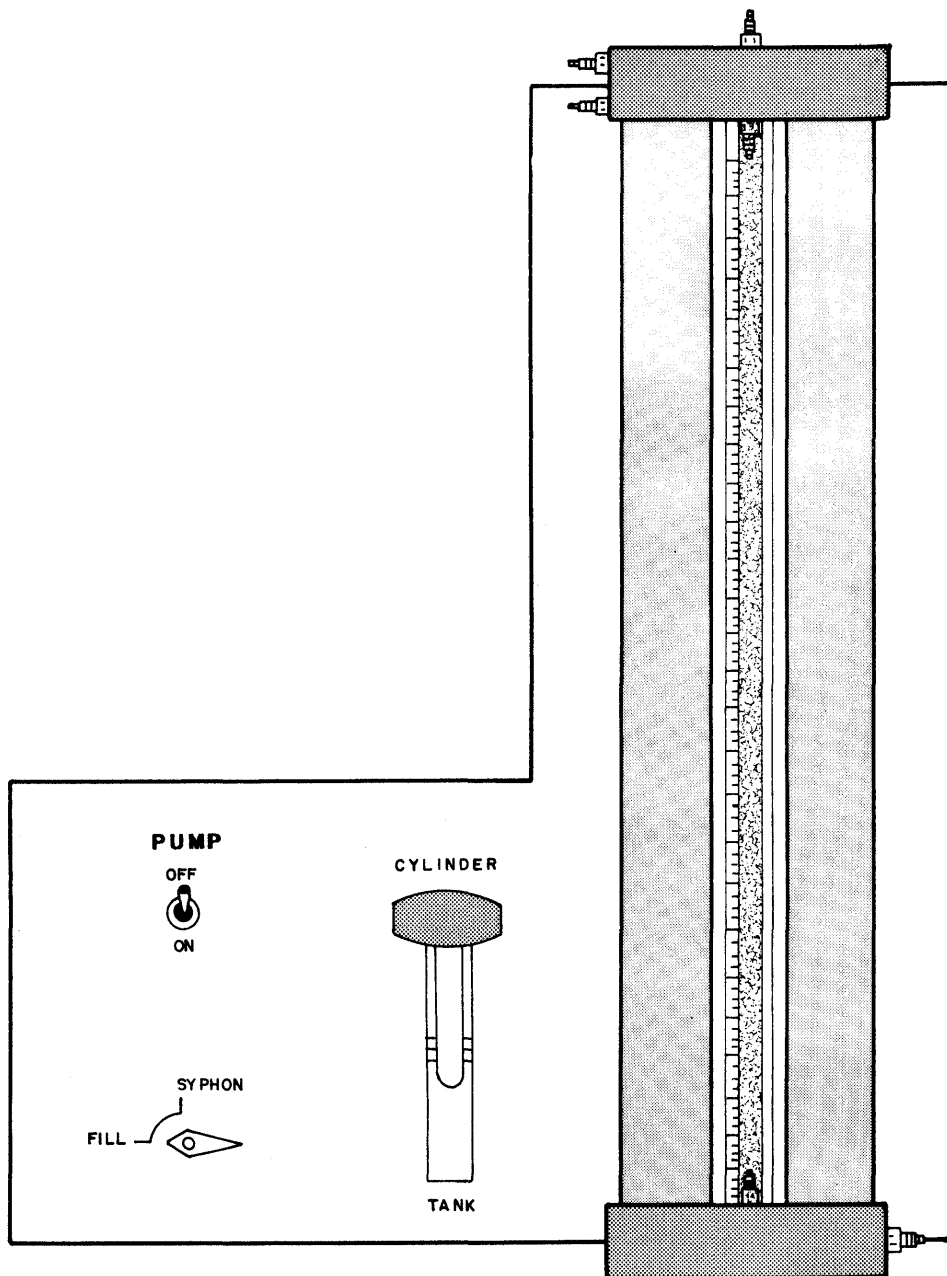

FIGURE 6.2 - DIESEL SYSTEM PANEL LAYOUT

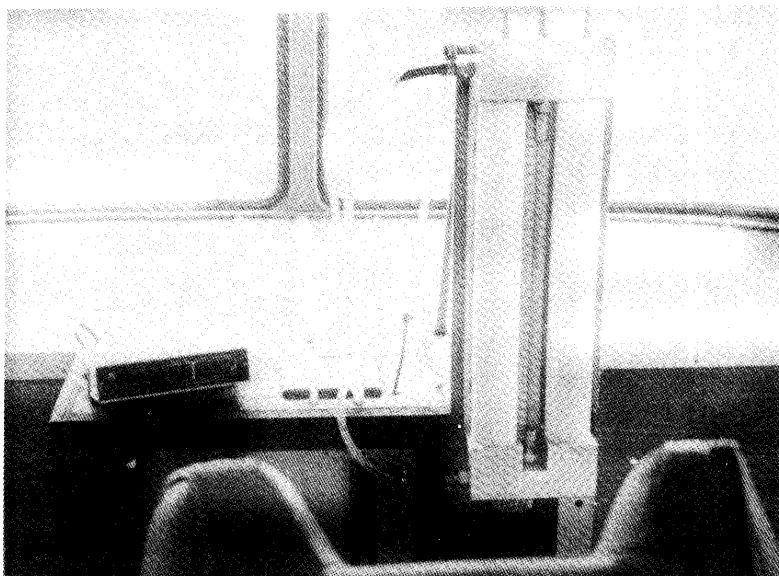

FIGURE 6.3 - RESERVOIR FUEL METER INSTALLED IN A VEHICLE

on the method used to make an accurate scale is covered in a Project Instrumentation Memo (Buller, "Reservoir Fuel Meters").

Two companion instruments were used with the fuel meter to determine speed and distance. They were the DMI, described in Chapter 3, and the split-second hand stopwatch shown in Figure 6.4. The DMI is an electronic, precision, digital odometer used to measure the distance travelled during a measurement run. The stopwatch was used to measure the time of the run. Together the data were used to calculate the average speed.

### 6.2.1 Accuracy of the Measurements

In this system, the accuracy of the reservoir fuel system depends on the accuracy and resolution of the instrument scale; the accuracy with which the reading is taken; the accuracy in operating the supply tank/cylinder valve with regard to distance; the accuracy of measured travel distance and having a leak-free system.

If a plastic measuring cylinder with its own scale is used as shown in Figure 6.5, the resolution depends upon the size of the cylinders used. The 250 ml cylinder scale has a resolution of 2 ml; the 500 ml cylinder scale, 5 ml; and the 1000 ml cylinder scale, a resolution of 10 ml.

If better resolution is required, the user's own scale can be employed as depicted in the diesel system panel layout diagram (Figure 6.2).

### 6.2.2 Field Operation

The field crew consisted of two people, a driver and an observer. The driver was trained to drive in a standard manner to minimize the effects of driver behavior on fuel consumption. The observer operated the equipment and recorded the various data on the field form shown in Table 6.1. Normally, the entire fuel consumption fleet travelled and worked together. The team was headed by a field supervisor who handled logistical problems and directed the activities of the fuel consumption team.

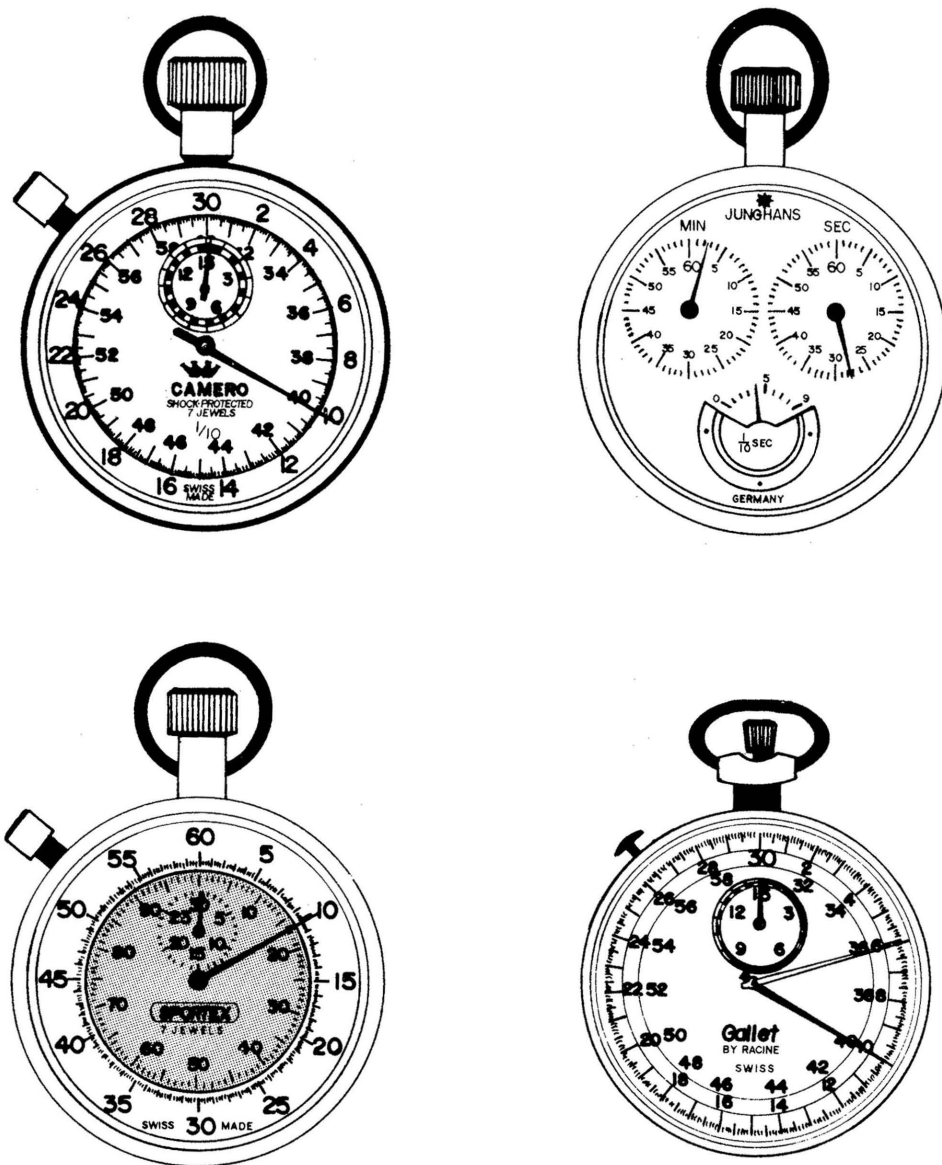

FIGURE 6.4 - MECHANICAL STOPWATCHES

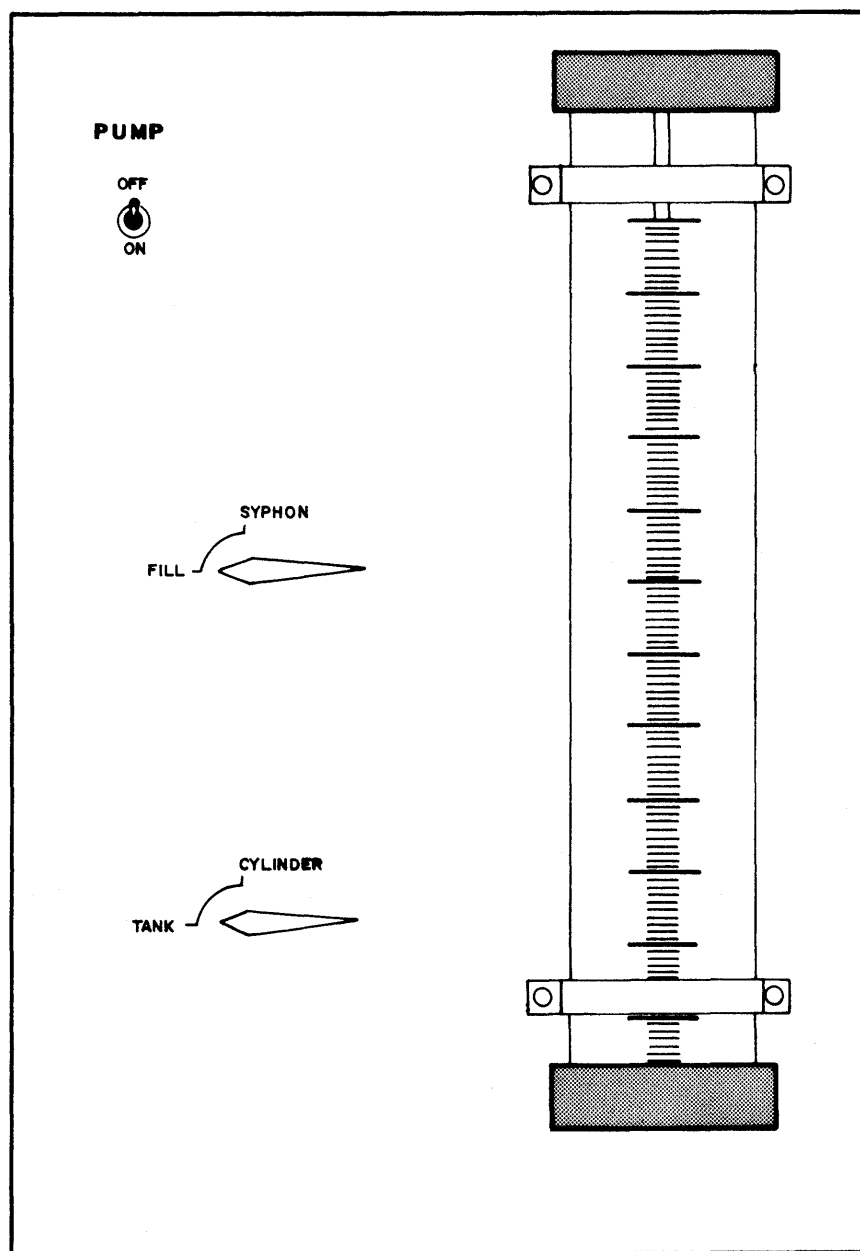

FIGURE 6.5 - GASOLINE SYSTEM PANEL

The vehicle was driven to the test site and the tire pressure measured on arrival. This ensured that the tires were warmed up. The vehicle was then loaded with the weight required for the test.

The driver made a trial run in the appropriate gear and designated speed for the first test. During this run the observer checked the DMI calibration. If the DMI was out of calibration, the vehicle DMI was calibrated on a measured road course.

At the test site, the vehicle was stopped before the test section to allow it to accelerate to the desired speed. The observer filled the fuel meter to a level slightly above the top mark on the scale and syphoned off the excess, leaving the fuel level at the correct starting point level. He then turned on the DMI and pressed the RESET and HOLD switches.

The driver accelerated to the desired speed and as the vehicle passed the starting mark, the observer released the HOLD switch on the DMI and it started measuring travel distance. When the DMI indicated 500 meters, the observer simultaneously started the fuel meter and stopwatch. At 1000 meters, he stopped one hand of the split second hand stopwatch. At the 1500 meter mark, stopwatch and fuel meter were simultaneously switched off. The vehicle stopped and the data recorded on the form shown in Table 6.1. Detailed descriptions of the field operation are covered in Project Technical Memos (Kaesehagen and Zaniewski, No. 5/76; Buller and Linder, No. 005/78).

### 6.2.3 *Recommended Maintenance Facilities (Fuel Meters Only)*

Electronics Technician  
Mechanic  
Volt-ohm meter  
Hand tools

## 6.3 THE VOLUMETRIC FUEL METERS

These were commercial fuel meters and they were used to measure fuel consumption over distances greater than permitted by the capacity of the reservoir fuel meters. Two models of this type were used,

the Fluidyne and the Columbia.

The Fluidyne is a very accurate, precision-machined, expensive instrument, which was quickly removed from service because it was damaged by contaminants normally found in the local fuel. It was not suitable for use in rugged environments.

The Columbia systems model was better suited for the project and the operational environment, but its resolution was much less than the Fluidyne. However, its cost was about one quarter of that of the Fluidyne and its lower precision construction allowed repairs to be made by the PICR team, rather than the manufacturer. The Columbia system consisted of a fuel filter, flowmeter, electro-mechanical digital readout unit and a diesel return-fuel tank. The major components are shown in Figure 6.6. A schematic diagram of the Columbia system is shown in Figure 6.7.

#### 6.3.1 *Field Operation*

This is basically the same for both systems and consists of setting the display to zero or noting the reading displayed at the start of the measurement distance, driving the vehicle to the termination point and noting the final reading. The difference between these two readings is the amount of fuel consumed over the distance indicated on the Distance Measuring Instrument or the vehicle odometer.

The only difference between the two makes is that the Fluidyne readout unit must be reset whenever the engine is started and read before it is switched off. This can require that a series of readings be summed to obtain the total amount of fuel consumed over a long distance. The Columbia readout is unaffected by engine starts and stops.

#### 6.3.2 *Accuracy*

Since this system has a digital readout, reading errors are eliminated and accuracy depends solely on the accuracy and resolution of the instruments used.

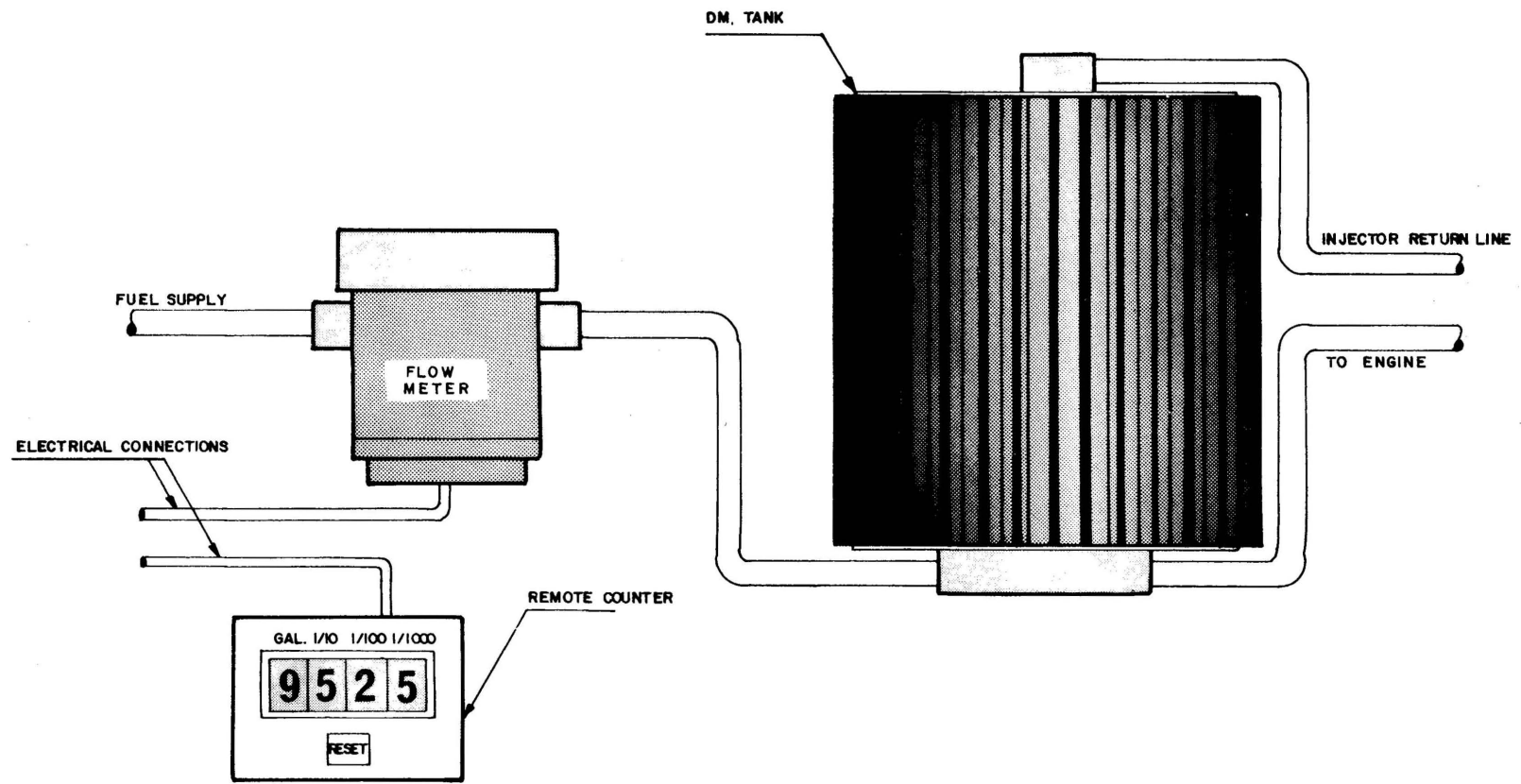

FIGURE 6.6 - COLUMBIA SYSTEM



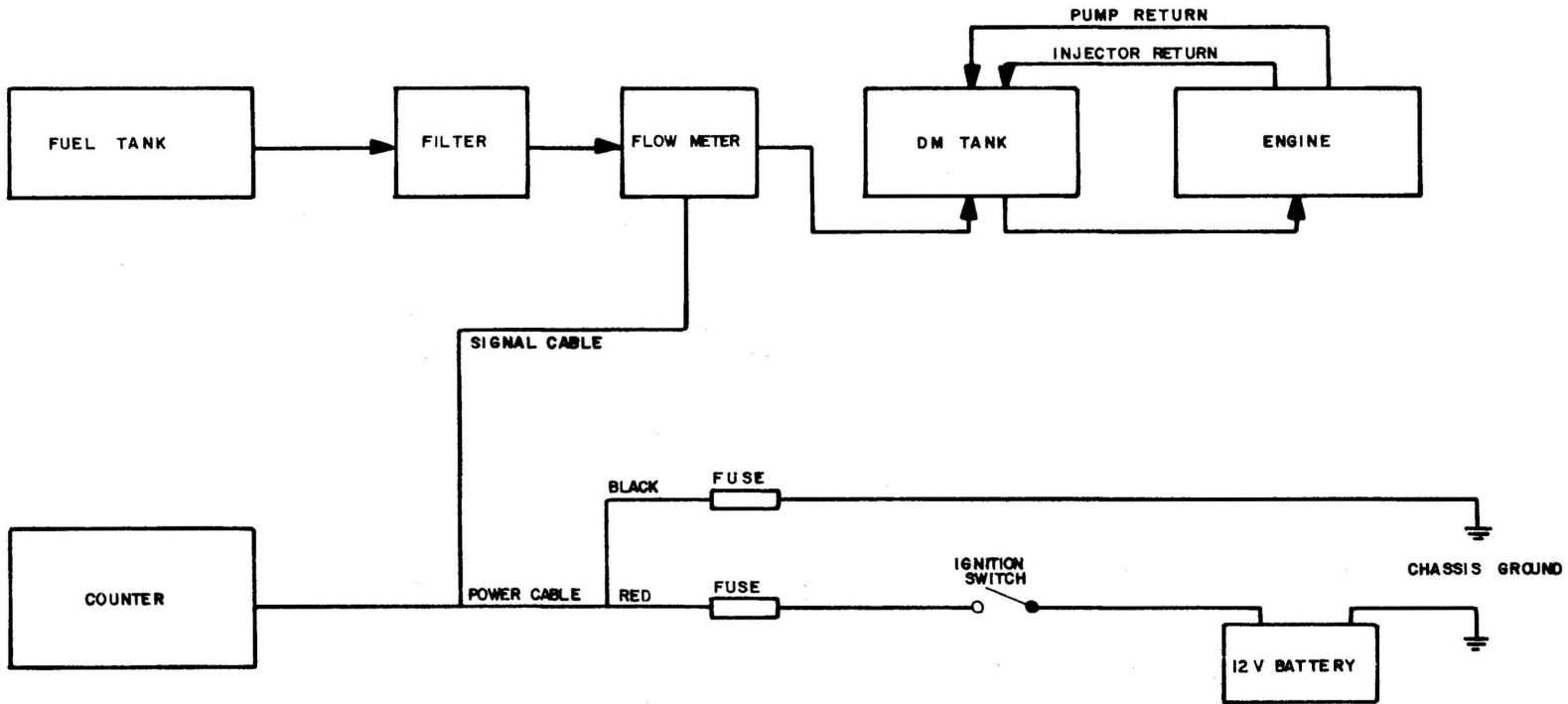

FIGURE 6.7 - COLUMBIA INSTALLATION DIAGRAM

The resolution of the Columbia fuel meter is 1/100 of a U.S. gallon for one model and 1/1000 of a U.S. gallon for a second model.

The resolution of the Fluidyne fuel meter is to a milliliter, the distance measuring instrument to 1/10 meter, and a vehicle odometer to 1/10 kilometer.

### 6.3.3 *Sources of Problems*

Initially, fuel pressure problems were encountered on some of the larger vehicles requiring a larger fuel pump to be fitted in place of the vehicle's existing pump. The 1300 cc Volkswagen never was able to use either fuel meter due to insufficient fuel flow. Every type of pump available was tried but none worked. Finally, a reservoir type fuel cylinder was installed on the VWs for long-range fuel measurement.

Air leaks at connection points occurred during installation causing inaccurate readings. These could have occurred again due to vibration, but did not during the short time the instruments were in service.

CHAPTER 7  
TRAFFIC COUNTERS



## 7.1 INTRODUCTION

The Traffic Counters were used by the Pavement Study Group to determine traffic flow rates on specific road sections under study.

The three types of automatic traffic counters shown in Figure 7.1 were used. They were the Leopold and Stevens recording traffic counter with a perforated paper tape readout, the Streeter Amet Junior traffic counter (with a pneumatic tube), and the Fischer and Porter 3000 loop detector traffic counter. In addition to the automatic type of counter, two manual counters were used. They were multiple-tally boards, containing six manual mechanical counters mounted on a clip board, and the Keuffel and Esser 89-1100 hand-held manual mechanical counter.

A number of manufacturers of automatic traffic counters were considered. The selection was made based on recommendations of the owners of the particular traffic counters purchased. The units were selected to cover a variety of applications. The manual counters were purchased to provide high mobility for short-term counts at specific locations.

In general, battery maintenance proved to be the most difficult problem with all of the automatic counters. Batteries in Brazil are quite expensive and generally of low quality. It proved impractical to import batteries for the traffic counters, because of the short shelf-life of dry cell storage batteries and the uncertainty regarding when and how many batteries would be needed.

When possible, traffic counters were located at police posts on road sections. If this could not be done, the counter itself was buried at the site in order to hide it. Prior to this practice, two counters were stolen. The Leopold and Stevens counters have rechargeable batteries and were supplied additional power by fitting main powered battery chargers on them. These counters were kept at police posts but occasionally their batteries would run down. In some cases the outbuilding, housing the counter, had only a single electrical outlet and the assumption was that other devices superseded the traffic counter in importance.

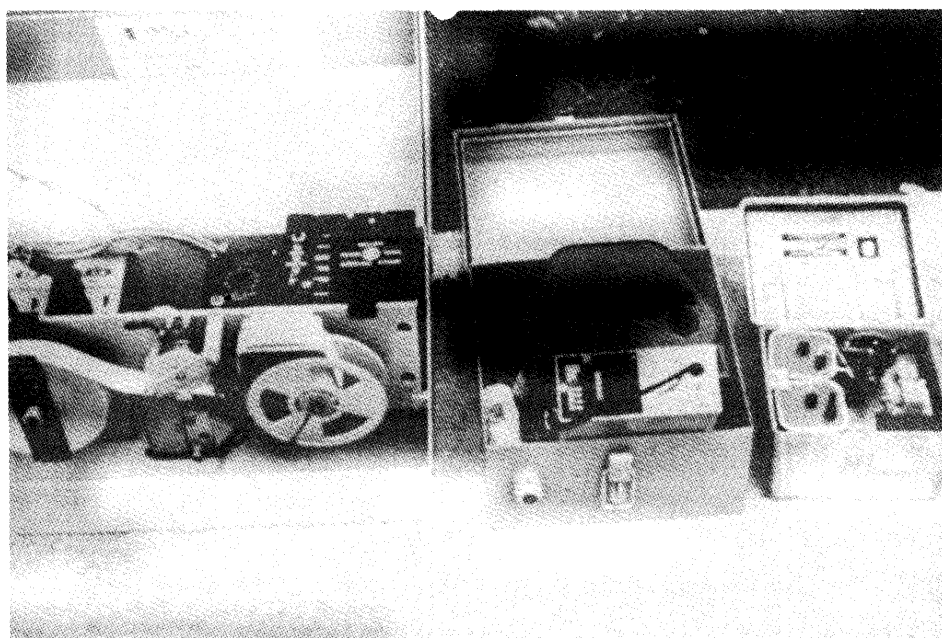

FIGURE 7.1 - THREE TYPES OF TRAFFIC COUNTERS USED IN THE STUDY

## 7.2 LEOPOLD AND STEVENS COUNTER

The Leopold and Stevens counter delivers its output on teletype compatible punched paper tape which is also directly readable. This feature eliminated the need for the operating staff to monitor the counters at frequent intervals. The traffic count is summed and punched on the tape at selectable time periods, from 5 to 60 minutes. The counter can be used as a sensor on either loop detectors or pneumatic road tubes. It can simultaneously record traffic in both directions or in two lanes of the same direction. The supply of tape lasts months without the need for changing, depending on the output interval used.

### 7.2.1 *Installation and Operation*

The traffic counter installation required cutting the pavement surface for the installation of the loop detector wires. Also, a main power source was required.

Operation required that the installer turn on the power, install a fresh reel of paper tape and press the RESET switch to start the timer at zero. Also, the configuration switches were set to cause the output format to reflect the number of loops and direction of traffic per loop.

### 7.2.2 *Maintenance*

The Leopold and Stevens counter is a well-designed and constructed instrument. However, it was difficult to keep these units out of the workshop and in the field. The CMOS circuitry used in this sophisticated device is susceptible to destruction from high static charges that may be introduced onto the circuit boards by handling them. The unusually high circuit failure rate experienced with these units indicated that the circuit boards were mishandled by the installer in an attempt to "get a counter going" from some real or imagined malfunction. Regardless of the cause, it is recommended that these counters not be used in exacting environments.

Two counters were hit by lightning. Both were repaired, however.

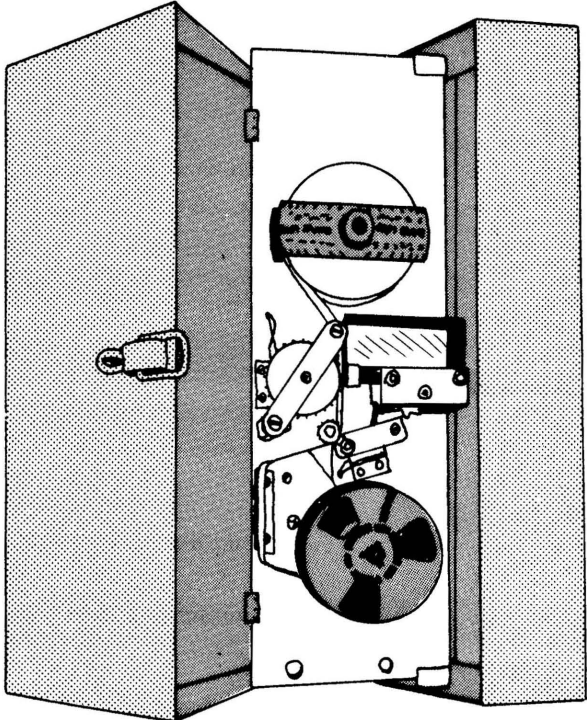

FIGURE 7.2 - LEOPOLD & STEVENS TRAFFIC COUNTER



### 7.2.3 *Recommended Repair Facilities*

One electronics engineer  
One top electronics technician  
Volt-ohm meter  
Oscilloscope  
Hand tools

## 7.3 *FISCHER AND PORTER COUNTER*

The Fischer and Porter 3000 Counter is of the loop detector type, supplied with an electromechanical counter to record traffic flow. It records only one lane or direction at a time. These counters were generally used at remote locations and buried at the site for concealment. They are powered by a large 7.5 volt dry cell battery housed in the same steel box as the counter unit. No sensitivity adjustments or controls are required of the operator, which makes the unit simple to use. The counters must be read at frequent intervals to establish the periodic traffic flow rate desired. This kept the installer quite busy visiting each installation to recover data counts. Figure 7.3 shows the counter.

### 7.3.1 *Maintenance*

As previously mentioned, the battery situation created the major maintenance difficulty with these counters. The type of battery required was unavailable in Brazil. The problem was solved by constructing batteries from large "Bell battery" single cells configured to supply the 7.5 volts needed.

These counters proved to be very reliable. The only required repairs were from damage inflicted by a leaking battery and from water damage when the counter was submerged during a heavy storm.

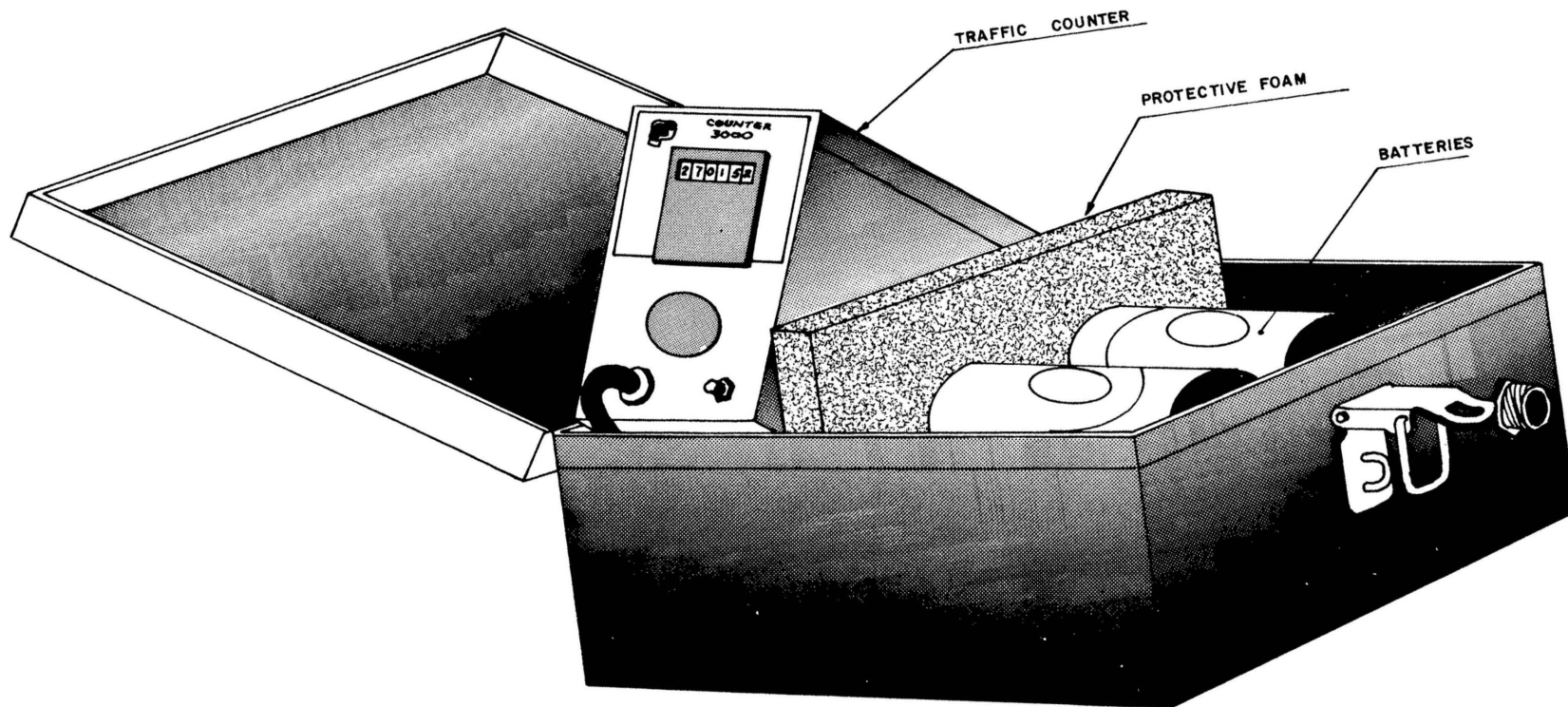

FIGURE 7.3 - FISCHER & PORTER COUNTER 3000

### 7.3.2 *Recommended Repair Facilities*

One electronics technician  
Volt-ohm meter  
Oscilloscope  
Hand tools

## 7.4 *STREETER AMET COUNTER*

The Streeter Amet junior traffic counter is a small battery-powered pneumatic tube counter. Its readout is an electromechanical register viewable through a small window in the traffic counter cover. It only accommodates one tube so it cannot distinguish between traffic lane or direction. The counter is illustrated in Figure 7.4.

Such counters were used at remote sites and chained to an immovable object for security purposes. Nevertheless, two of them were stolen from their roadside position. In general, the road tube was not a suitable type of sensor because the very coarse texture of many of the roads prematurely shortened the life of the thick rubber tubes.

The junior traffic counter has two adjustments, one for sensitivity and the other for wave suppression within the tube itself. These adjustments interact, which makes them too complicated for project field personnel. If the controls are poorly tuned, the result can be either a multiple register from a single axle or no register at all from lightweight axles. It is possible to tune out lightweight vehicles all together. Because the loop detector traffic counters proved easier to maintain, even on unpaved roads, the junior traffic counter was used infrequently during the study. Nonetheless, because of its simplicity, low cost, and freedom from maintenance difficulties, this counter is recommended for use in situations favorable to road tubes in environments where qualified maintenance personnel are available.

### 7.4.1 *Maintenance*

As previously mentioned, road tube replacement was the major maintenance problem. The battery used in this counter is a very common

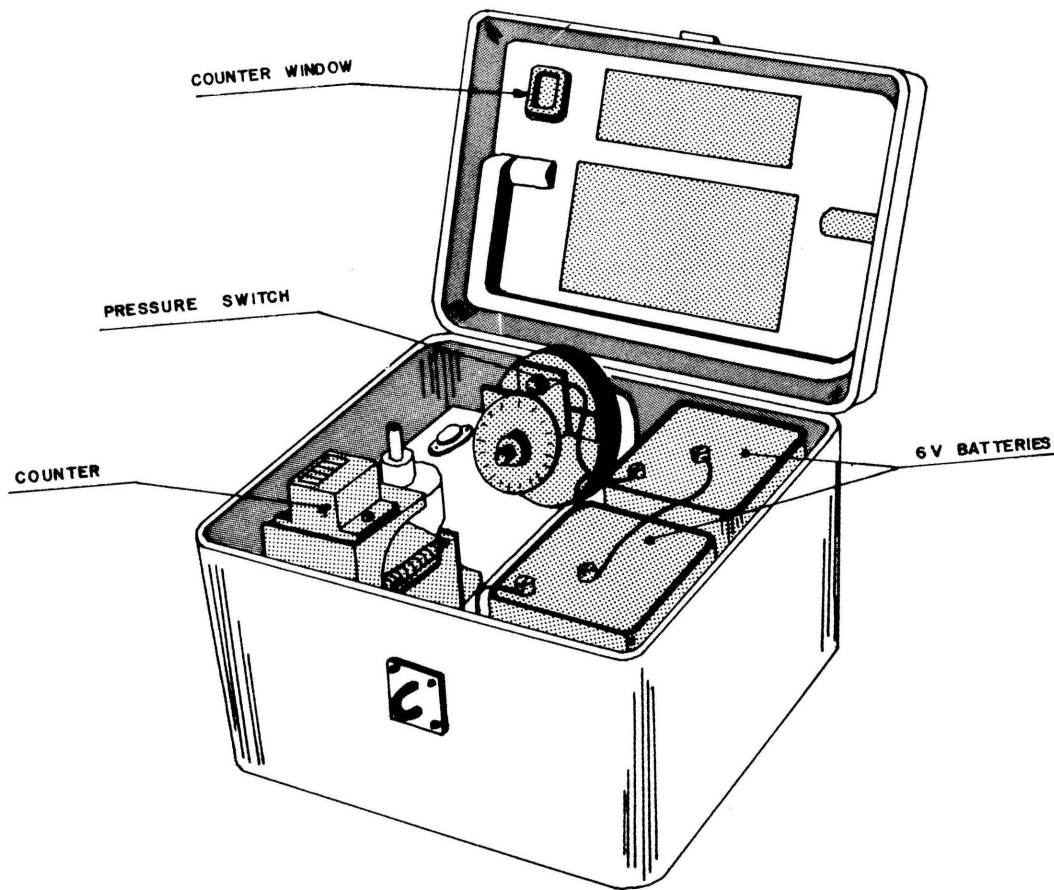

FIGURE 7.4 - STREETER AMET TRAFFIC COUNTER

6 volt lantern type, readily available in Brazil. In this respect, the junior traffic counter was the easiest of the three to maintain. Aside from road tubes and batteries, there were no maintenance problems. This counter is very simple in design.

#### 7.4.2 *Recommended Repair Facilities*

One technician  
Volt-ohm meter  
Hand tools

#### 7.5 **MANUAL COUNTERS**

Two types of Manual Counters were available and are shown in Figures 7.5 and 7.6. They were used infrequently and presented no maintenance problems or requirements.

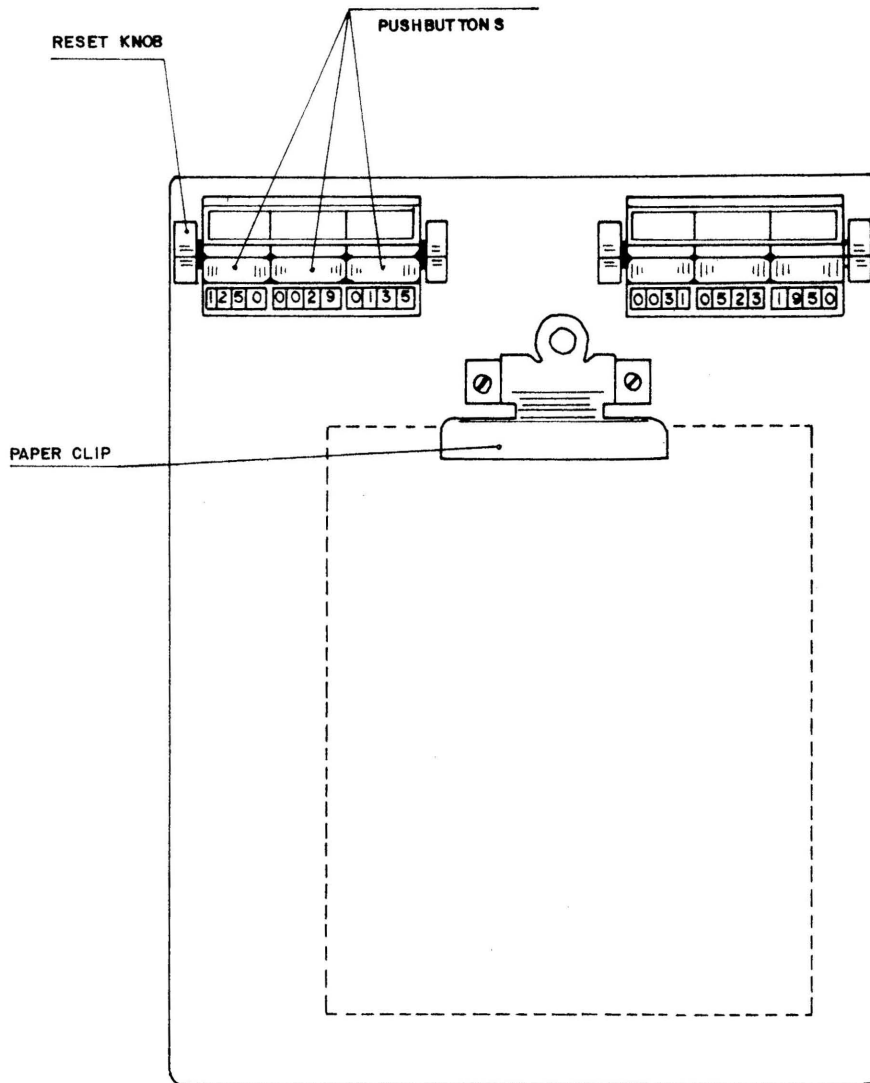

FIGURE 7.5 - MULTIPLE TALLY

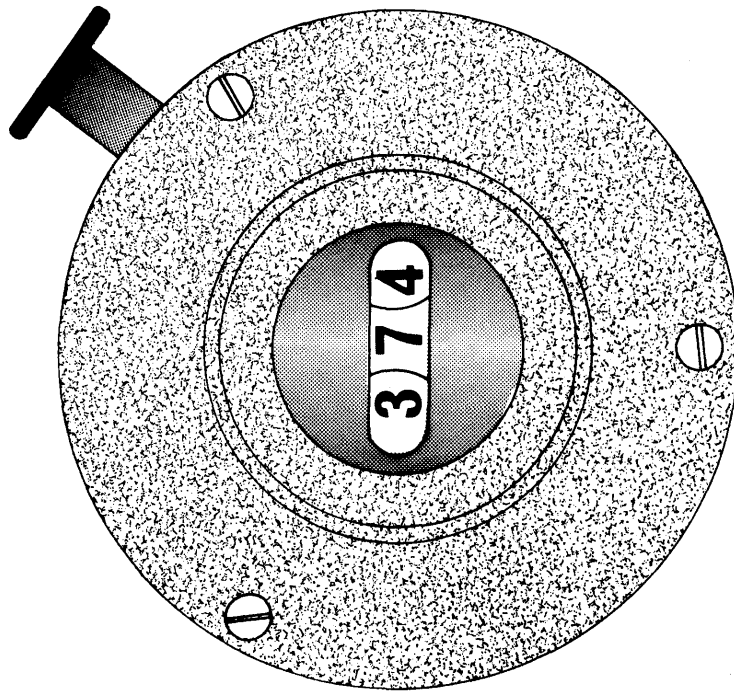

FIGURE 7.6 - TALLY REGISTER





CHAPTER 8  
VEHICLE WEIGHT MEASUREMENTS



## 8.1 INTRODUCTION

Two types of scales were used to weigh vehicles during the study (Visser, Technical Memo No. 22/76). The Pavement Group used the scales to obtain a sampling of typical axle loads on the road sections under study. The majority of the weighings were made using a portable scale. The other scale was a sophisticated computerized weigh-in-motion system, capable of weighing vehicles while they are travelling at highway speeds. The latter experienced an abnormally high rate of failures during the entire project.

## 8.2 THE PORTABLE WHEEL-LOAD WEIGHER

Four General Electrodynamics model MD500 portable wheel-load weighers were acquired for the project. This make and model was selected on recommendation of the Texas Highway Department Instrument Section, which had used this particular scale for over twenty years with no abnormal maintenance problems. Another important consideration was the low cost of the instrument.

### 8.2.1 Description

Capacity	20,000 pounds
Resolution	20 pounds
Weight of instrument	46 pounds
Dimensions	20-1/2" x 10-1/2" x 3"
Ramp slope	30 degrees

### 8.2.2 Field Operation

Usually a vehicle is selected from the traffic stream and stopped for a weighing. A pair of instruments are used at the same time, one under each wheel or dual wheels on the same axle to read the total axle weight. This instrument was used only during daylight hours, with the assistance of the highway police. Complete operating details are given in a Project Instrumentation Operational Memo (Buller, "Port-

able Wheel Load Weigher"). Figure 8.1 shows a general view of the instrument; Figure 8.2 schematically shows data flow and the actual data form is illustrated in Table 8.1.

The crew used for this operation included two operators and a driver who provided assistance in positioning the vehicle on the scale.

### 8.2.3 Maintenance

This consisted mainly of repairing or replacing physically damaged parts which were broken when the instrument was spun along the road by irate drivers accelerating away very rapidly after a weighing. This also caused instruments to need recalibration. Calibration details are given in a Project Instrumentation Operational Memo (Buller, "Portable Wheel Load Weigher"). Recessing the instrument into the middle of a block of hard wood 2m x 30cm x 7 or 8 cm with a ramp at either end reduced the indicated damage.

### 8.3 THE WEIGH-IN-MOTION SYSTEM (WIM)

This is an electronic apparatus that measures, displays and records the dynamic weight, number of axles, length and speed of vehicles travelling at normal highway speeds. It also can be used to measure, display and record static wheel loads. The equipment was furnished by Unitech Inc.

It was difficult to maintain the WIM in the field. When the WIM was working it was used to provide data for the pavement performance and maintenance study group covering the distribution of axles over 24-hour periods (Visser and Moser, "Pavement Performance and Maintenance Experiments"). Figure 8.3 shows a truck passing over WIM sensors at a test location. The data route diagram for the system appears in Figure 8.4. A simplified block diagram of the complete system is given in Figure 8.5. Each block is described below.

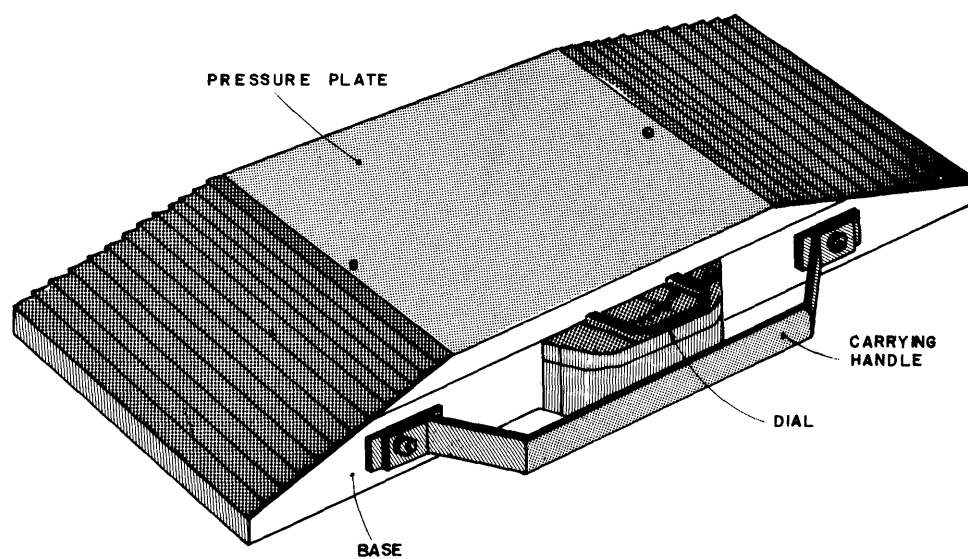

FIGURE 8.1 - PORTABLE WEIGHER GENERAL VIEW

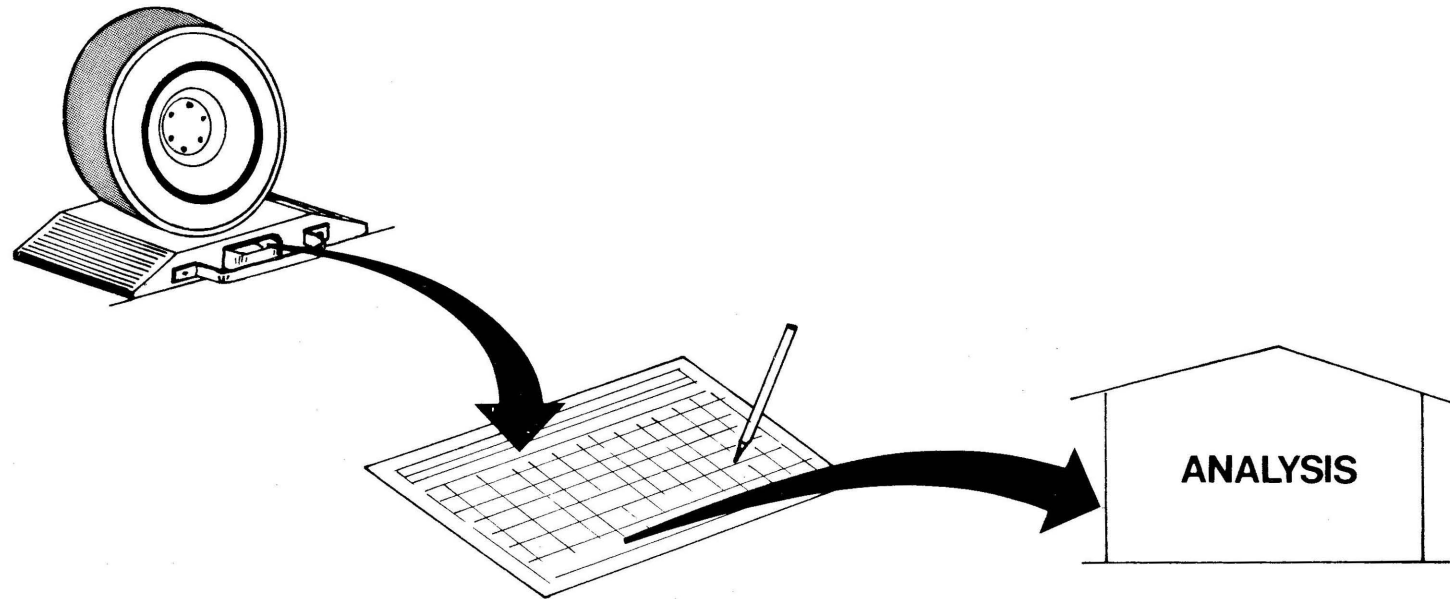

FIGURE 8.2 - PORTABLE WHEEL-LOAD WEIGHER DATA ROUTE DIAGRAM



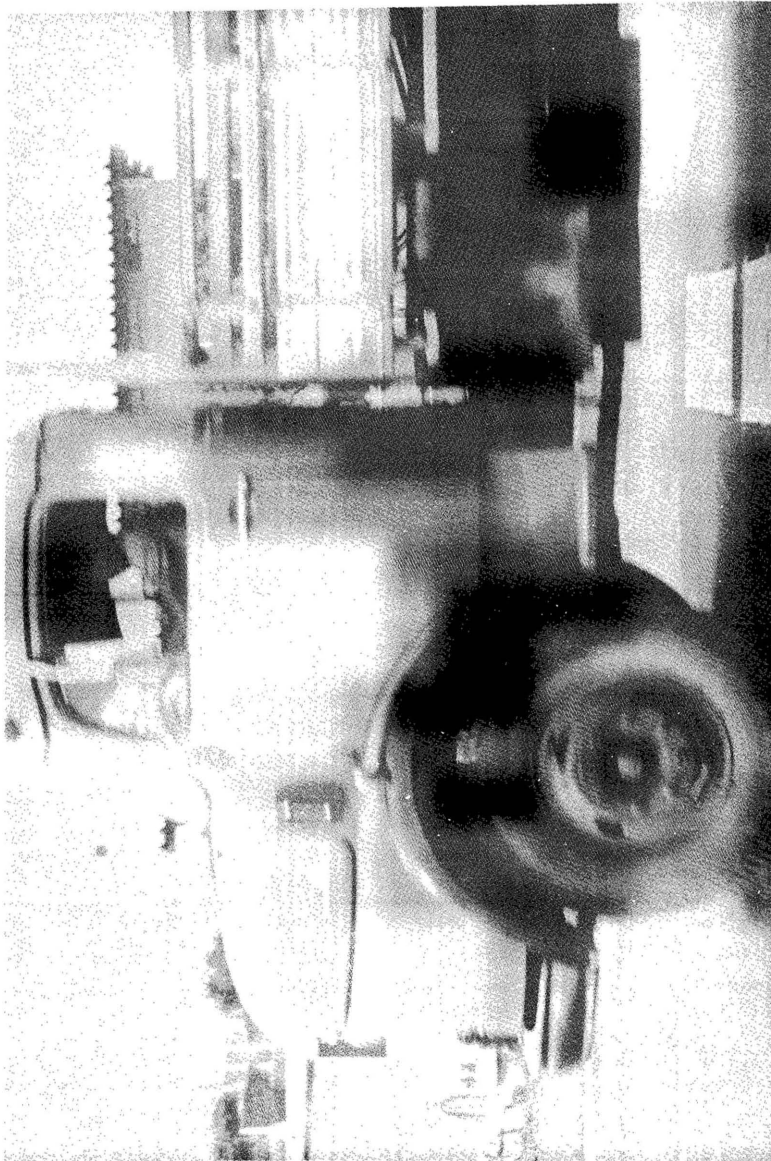

FIGURE 8.3 - TRUCK PASSING OVER WIM SITE



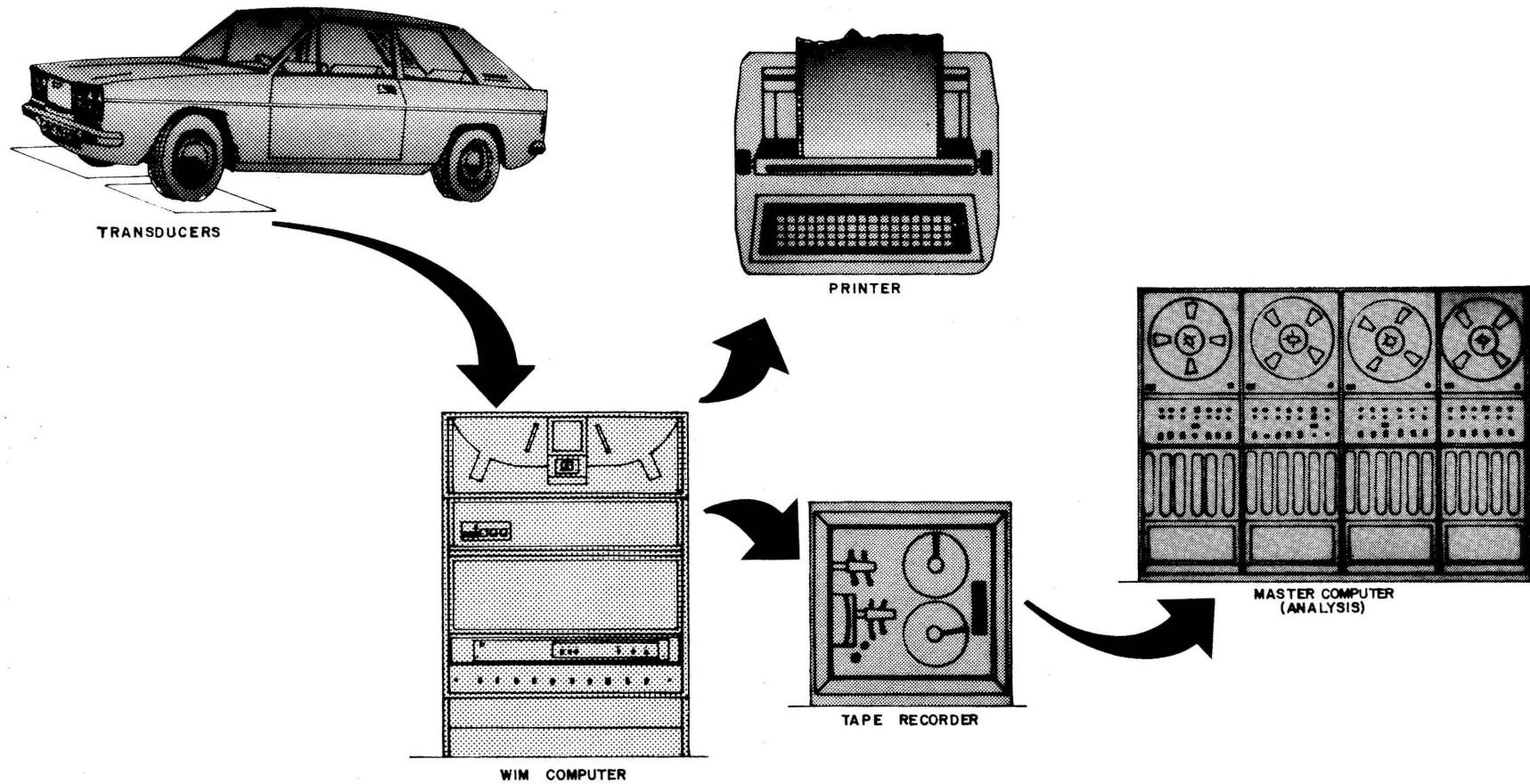

FIGURE 8.4 - WEIGH-IN-MOTION DATA ROUTE DIAGRAM

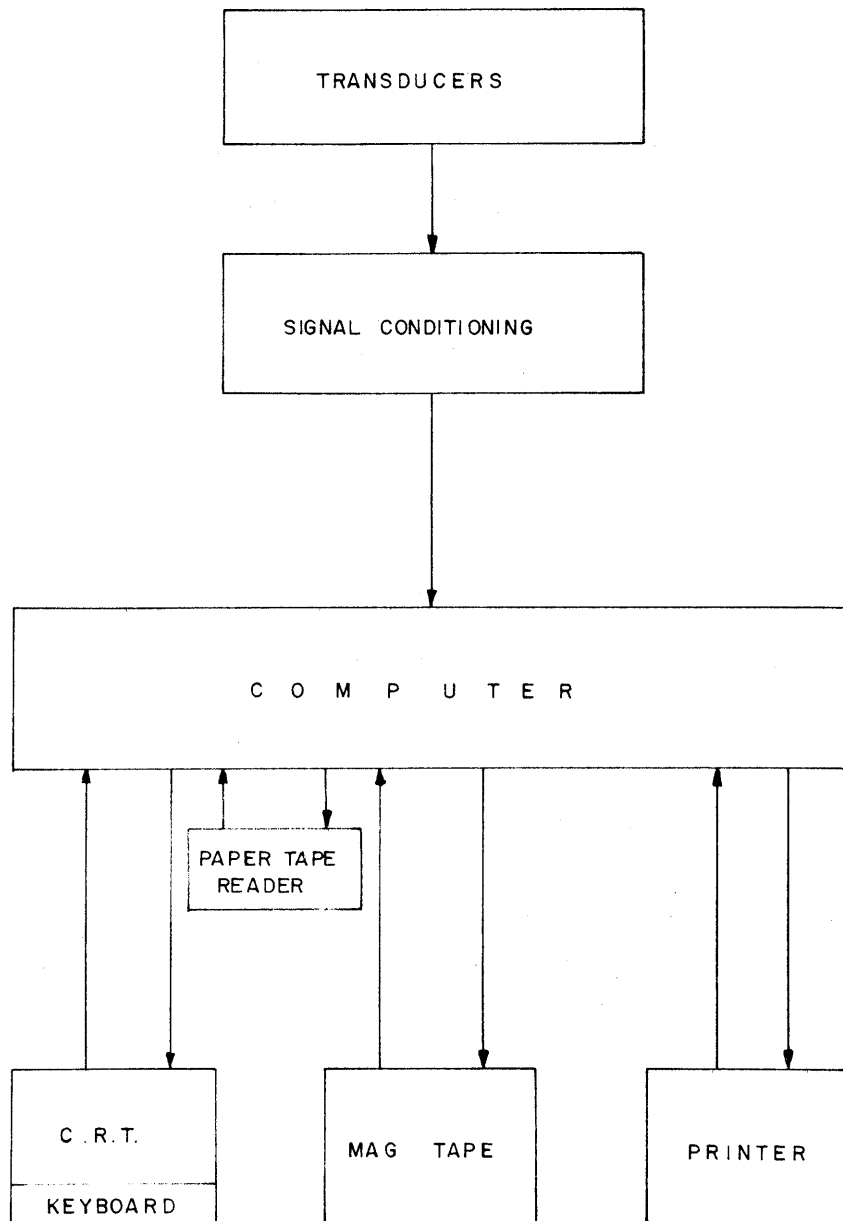

FIGURE 8.5 - SIMPLIFIED BLOCK DIAGRAM FOR WIM SYSTEM

### 8.3.1 *Sensors*

These are the components that are installed in the road pavement. They are used to collect data from a passing vehicle. They present it in the form of analog signals to the system. Two types of sensors were used:

#### A) Load Transducers

Two load-cell transducers were employed to collect weight and axle data, one for each wheel path. Each transducer consists of sixteen load-cells, eight of which are active and eight temperature-compensating. They are connected in a bridge configuration with four in each arm of the bridge. The arrangement is shown in Figure 8.6. The bridge is energized by a constant voltage and under "no load" conditions, gives a zero output. When a load is applied to the active load-cells, their resistance value is changed in proportion to the load applied and the bridge outputs a voltage in the same proportion. This signal voltage is then routed to the signal-conditioning unit.

#### B) Inductive Loops

These were used to collect speed and vehicle length data and to inform the computer of the "presence" of a vehicle over the transducers. Three loops were used: the first two provided the speed pulses and the third measured the vehicle length and informed the computer of the vehicle's presence.

The layout of the sensor installation is shown in Figure 8.7 and described in a Project Instrumentation Memo (Buller, "Weigh-In-Motion System") which also gives details on the method of making the installation. Figures 8.8 through 8.11 show various stages of the installation.

Calibration procedures for the sensor is covered in a Project Instrumentation Operational Memo (Buller, "Weigh-In-Motion System").

### 8.3.2 *The Signal Conditioning Unit*

This unit converts the analog signals from the sensors into a digital form that the computer recognizes.

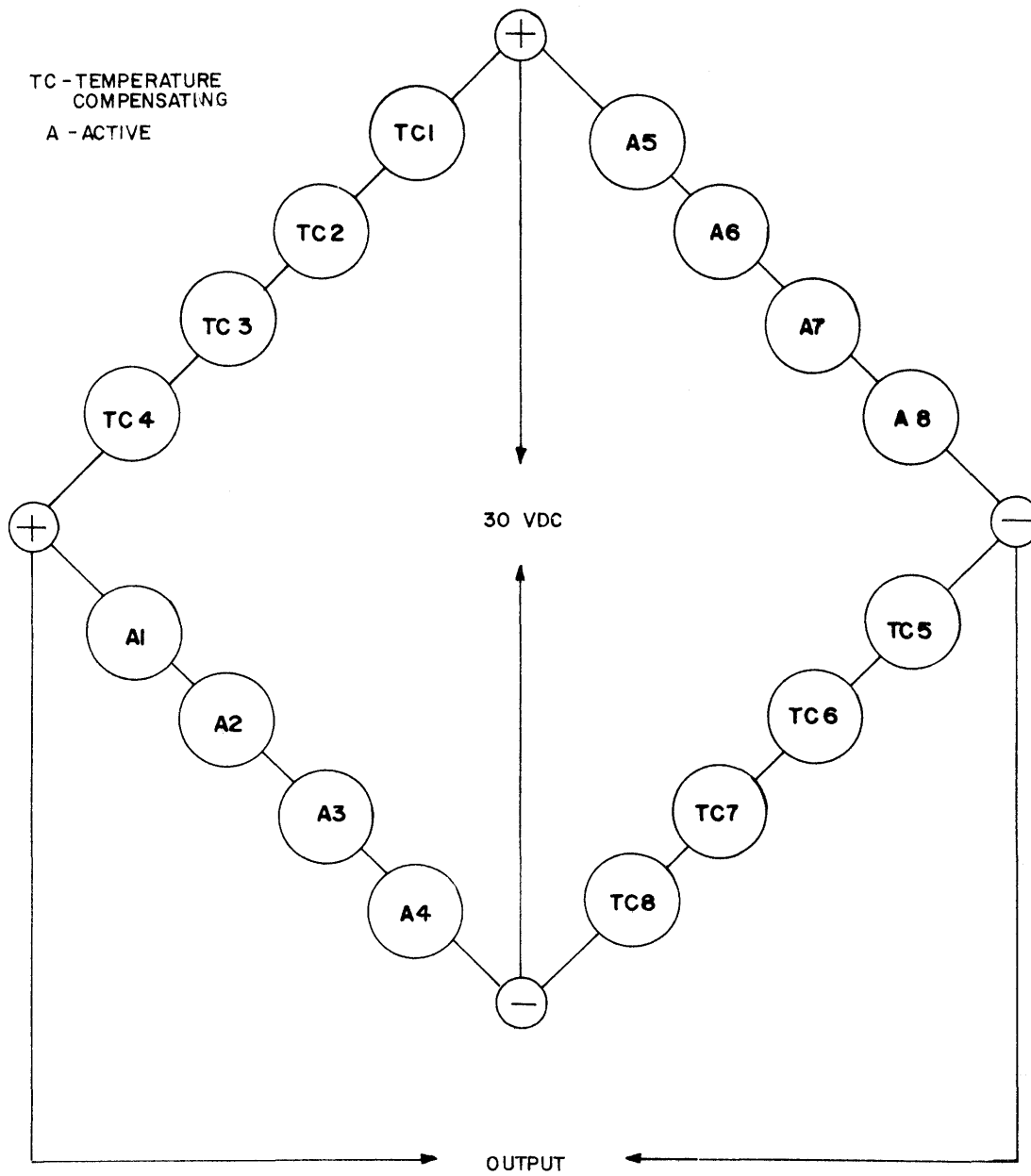

FIGURE 8.6 - LOAD CELLS BRIDGE ARRANGEMENT

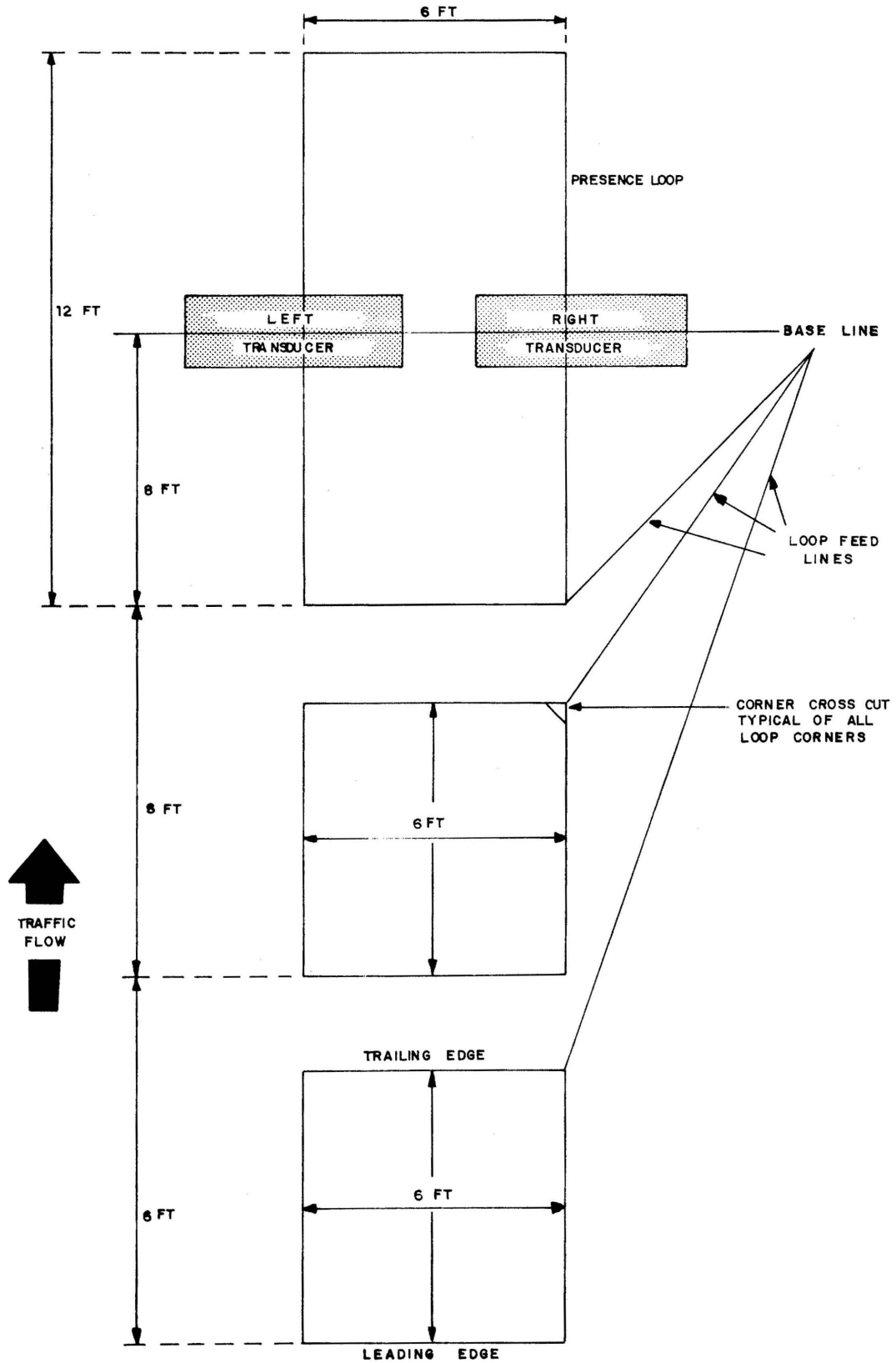

FIGURE 8.7 - TRANSDUCER INSTALLATION LAYOUT

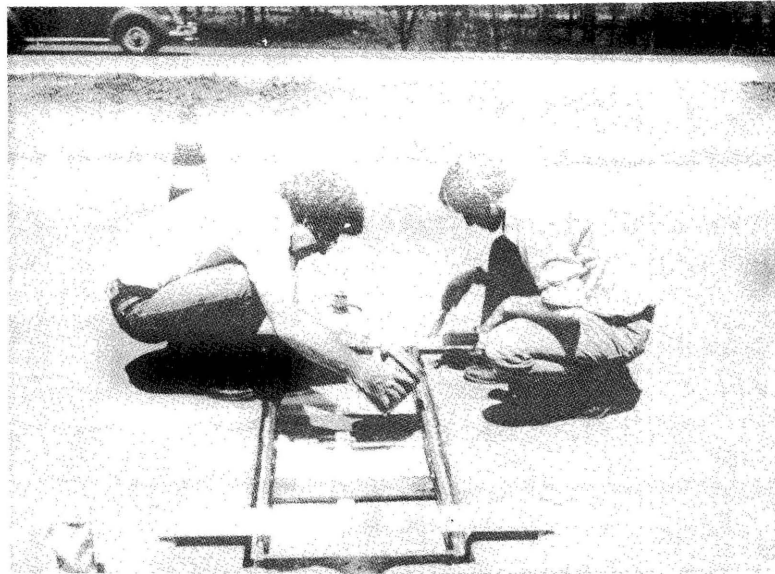

FIGURE 8.8 - TECHNICIANS LEVELLING TRANSDUCER SUPPORT STRUCTURE

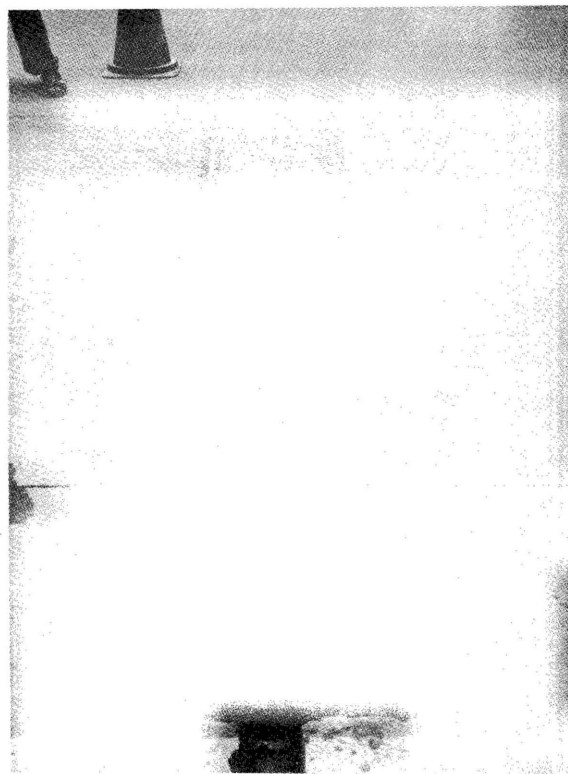

FIGURE 8.9 - INSTALLATION OF TRANSDUCER SUPPORT STRUCTURE

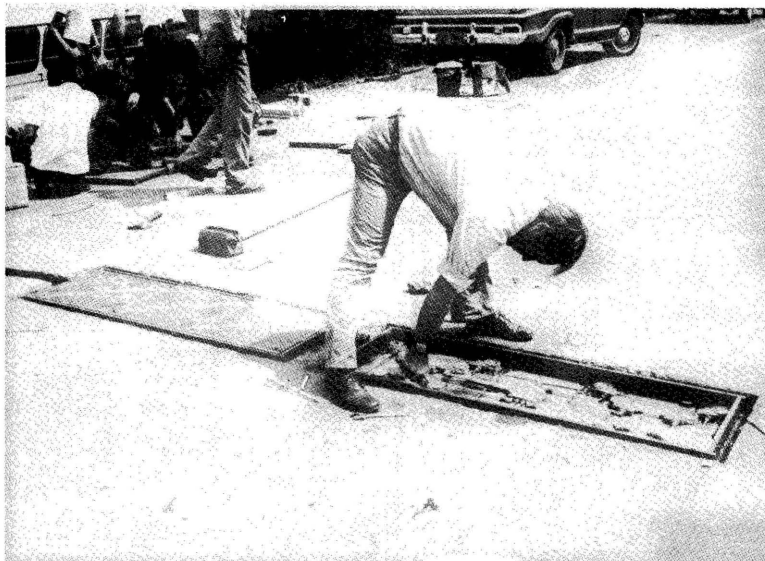

FIGURE 8.10 - TECHNICIAN ADJUSTING LOAD TRANSDUCER POSITION

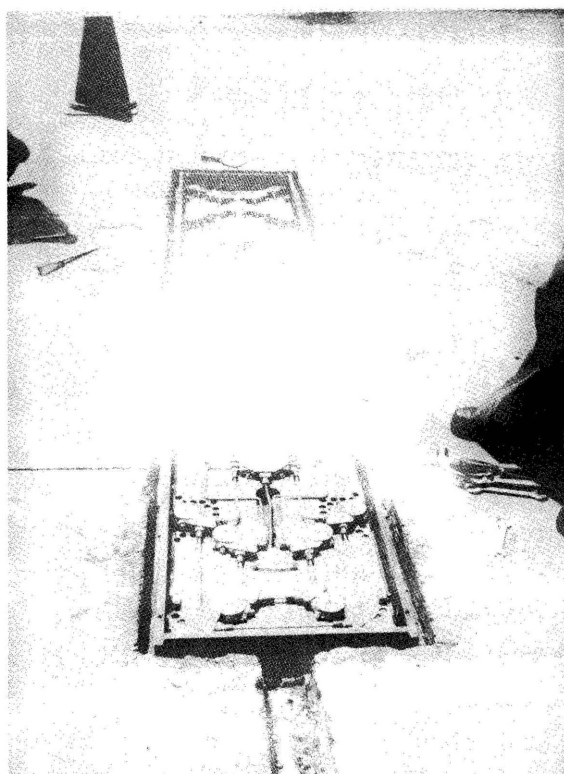

FIGURE 8.11 - LOAD TRANSDUCERS READY TO BE COVERED WITH PRESSURE PLATES

8.3.3 *The Computer*

The computer accepts the digital data from the signal conditioning unit, performs the required calculations to allow it to feed the data out in units of weight, length and speed. It also commands the operation of peripheral units at the appropriate times and produces the time-of-day for display and recording.

8.3.4 *The Video Unit (CRT)*

This unit receives data from the computer on command and displays the information in alphanumeric form.

8.3.5 *The Keyboard*

The keyboard is used by the operator to communicate with the computer and to enter additional data such as the vehicle class, site code number, and operator code number.

8.3.6 *The Magnetic Tape Unit*

This unit records the selected data on magnetic tape on command, providing that it receives correct data. The unit has data checking capability.

8.3.7 *The Printer*

This is an optional unit which can print the data as displayed on the CRT in the same format as the display. The format is as follows:

```

PESQUISA DE PESAGEM - KM 01 - BR 040.....(1)
0189   1529HRS   12/05/77 .....(2)
  1     2         3 .....(3)
D1659   3750     3700=9050.....(4)
E1650   3600     3850=9050.....(5)
  3300   7300     7500 .....(6)
    
```



```

          3.2      1.7      .....(7)
18114PB  5.0DE    11.1CC   46.9KMH,.....(8)
CLASSE DO EIXO = 5 .....(9)

```

Line (1) - is operator entered data giving a heading and the site location.

Line (2) - gives the equipment originated record number, time-of-day and the date.

Line (3) - shows the number of axles.

Line (4) - gives individual and total right-wheel weights.

Line (5) - gives individual and total left-wheel weights.

Line (6) - gives total axle weights.

### 8.3.8 *The Paper Tape Reader*

This is required for loading a program or diagnostic into the computer and is located at the top of the computer cabinet.

### 8.3.9 *Field Operation*

Items 8.3.2 through 8.3.8, described above, were installed in a trailer as shown in Figures 8.12 to 8.14. A functional description, details of the trailer installation and site selection guidelines are covered in a Project Technical Memo (Buller, "Weigh-In-Motion System").

The equipment requires an electricity supply of 115 volts at 60 Hz, provided by a 4 K.V.A. diesel generator set. This supply voltage was monitored by a voltmeter mounted inside the trailer. The generator set was transported in the trailer's tow-vehicle.

Transducer support frames were installed in the pavement at six sites in central Brazil. The weight transducers were installed immediately prior to a period of operation and removed immediately afterwards, leaving the frames filled with asphaltic concrete. Each of the installed sites was monitored over a seven-day period for twenty-four hours per day by three operators. The operating procedure is detailed in a Project Instrumentation (Operational) Memo (Buller, "Weigh-In-Motion System") which describes the three modes of operation, namely: manual, automatic and static. The Memo also gives calibration procedures, programming instructions, preventive maintenance and in-field trouble-

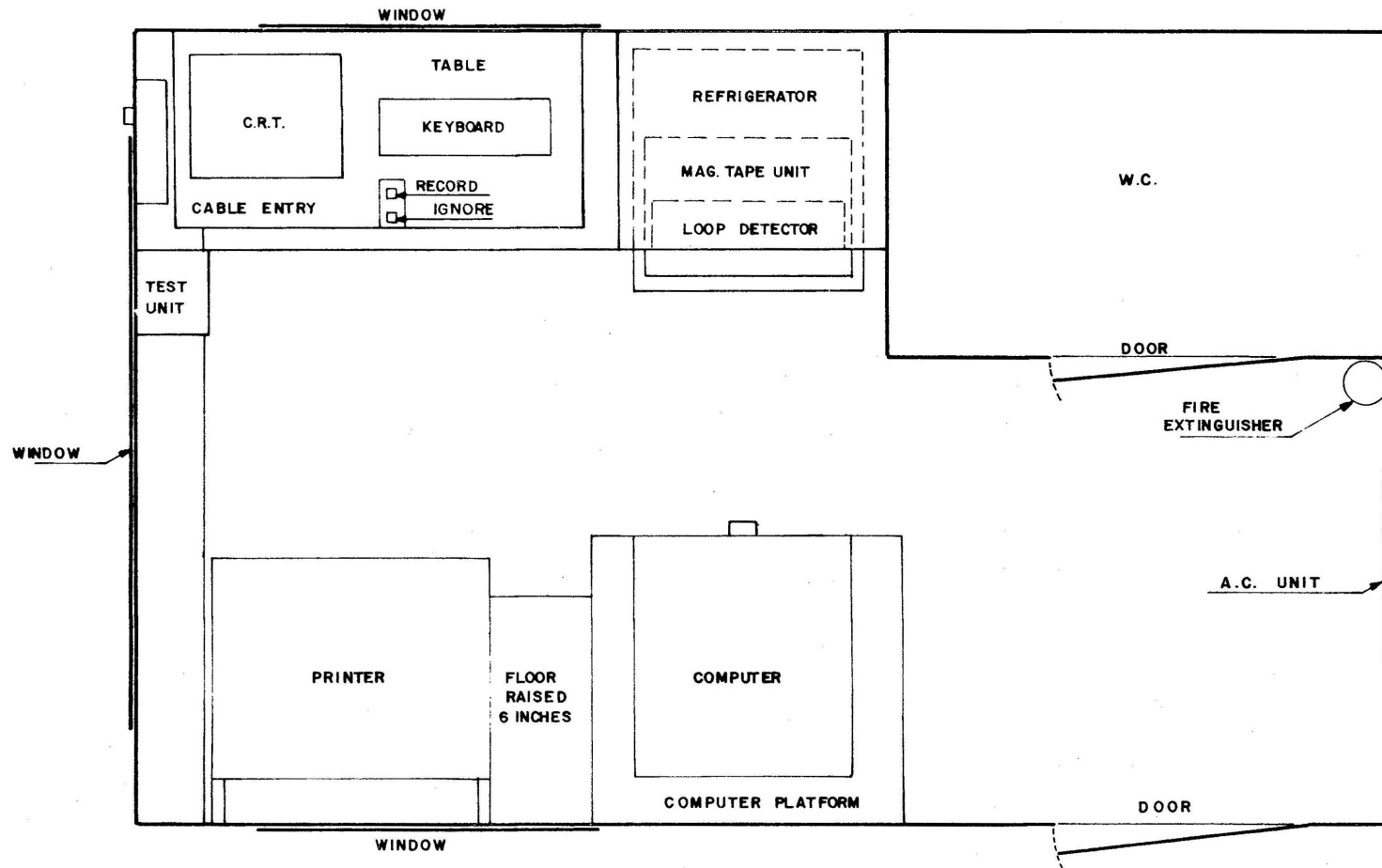

FIGURE 8.12 - TRAILER LAYOUT

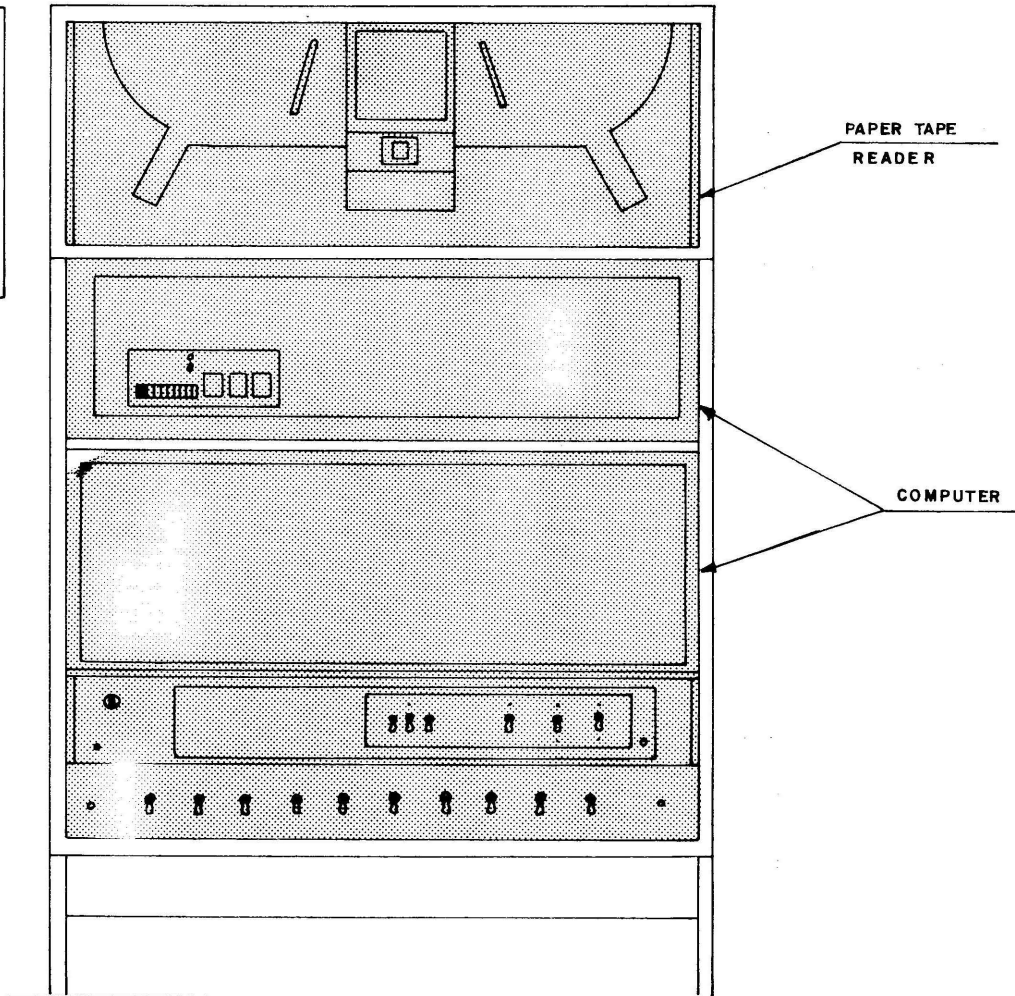
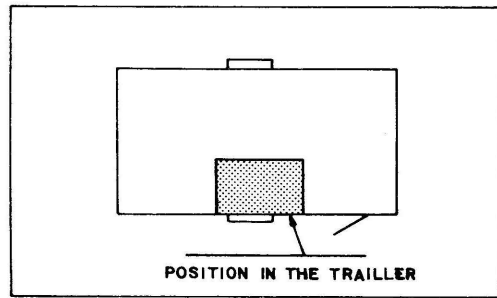

FIGURE 8.13 - COMPUTER RACK

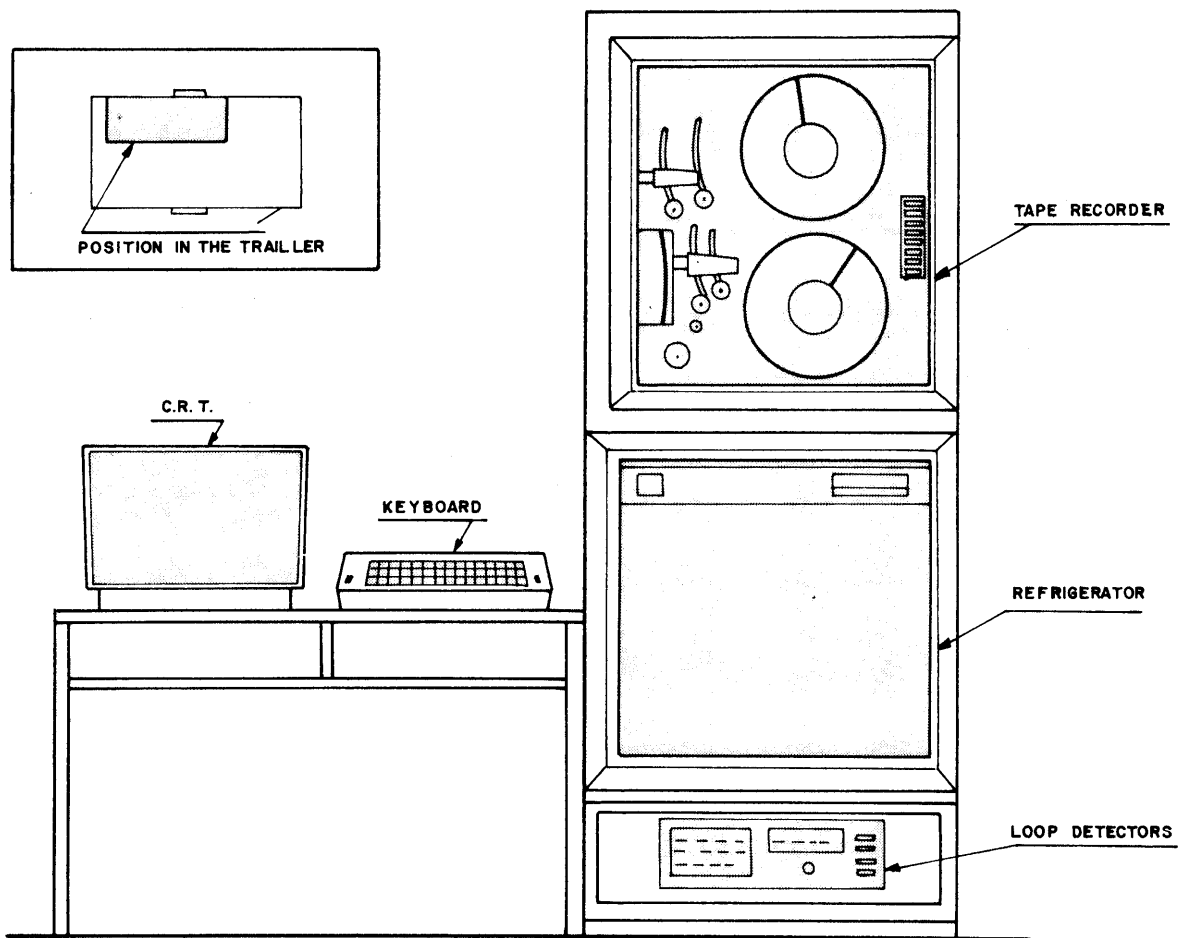

FIGURE 8.14 - PERIPHERAL EQUIPMENT

shooting guidelines.

### 8.3.10 Maintenance

The WIM system used during the study required repairs so frequently that its use was restricted to virtually a single trip to the six established test locations. Even on this single trip the data collection was frequently interrupted by malfunctions. The general opinion was that the equipment needed more development before it could be considered reliable.

The computer and peripheral equipment were designed to be operated at a permanent installation and consequently did not withstand the vibration that they were subjected to while being towed over thousands of kilometers of rough roads. This caused problems in the computer that remained unsolved even after several visits by technical personnel from Data General do Brasil, representative in Brazil for Data General Co., which manufactured the computer. Furthermore, all of the equipment was designed to be used in an air-conditioned clean atmosphere and was adversely affected following subjection to the dust-laden atmosphere of field work. Calibrating the sensors was always a problem and many load-cells had to be changed during the short operation period.

In brief, the WIM system experienced all the hardware and software problems that frequently occur with prototype equipment.

A discussion of some of the problems encountered with the equipment is presented in a Project Instrumentation Memo (Buller, "Weigh-In-Motion System").

### 8.3.11 Recommended Maintenance Facilities

One electronics engineer  
One electronics technician (senior)  
Oscilloscope  
Digital Multimeter  
Tools.



CHAPTER 9  
DATA CONVERSION EQUIPMENT





## 9.1 INTRODUCTION

Five of the instruments used to collect data during the project produce data in a form incompatible with the computer used for analysis. Hence, transformation to a different format was needed. Various data conversion apparatuses were used to reformat the data.

The primary device was the Analog-to-Digital (A-to-D) converter. It transcribed, on 9-track magnetic tape, the analog output from the Profilometer. It also transformed the punched paper tape output from the Leopold and Stevens traffic counter, and converted data from the Dynaflect, and the cassette tape from the traffic flow data logger. The Weigh-In-Motion System printer was used to convert the cassette tape output from the recorder box to printed form. These processes are depicted in Figure 9.1.

The camera box output appeared on super-8 movie film and was projected by Bell and Howell 8mm stop-motion projectors for transcription as shown earlier in Figure 4.8.

## 9.2 EQUIPMENT DESCRIPTION

The A-to-D converter shown in Figure 9.2 is an instrument featuring a 9-track magnetic tape transport, a teletype machine with paper tape reader and punch, a SANGAMO analog tape recorder identical to the one supplied with the Profilometer, and a microprocessor control unit. The control unit is programmed to accept commands from front panel switches for various types of operations. The A-to-D operator thus does not need to possess any knowledge of data processing or electronics. The A-to-D was acquired specifically to handle the Profilometer transcriptions and was specially constructed for this project by Texas Microsystem, INC..

The Tone-to-Digital converter was used in conjunction with the A-to-D for converting cassette tapes to a Teletype-like format. For this use, the A-to-D was modified to allow the Baud rate to be changed via a toggle switch from the 110 Baud rate needed for the Teletype to a 300 Baud rate compatible with the Traffic Flow Data Logger output. The Tone-to-Digital converter is a unique device designed and built by the

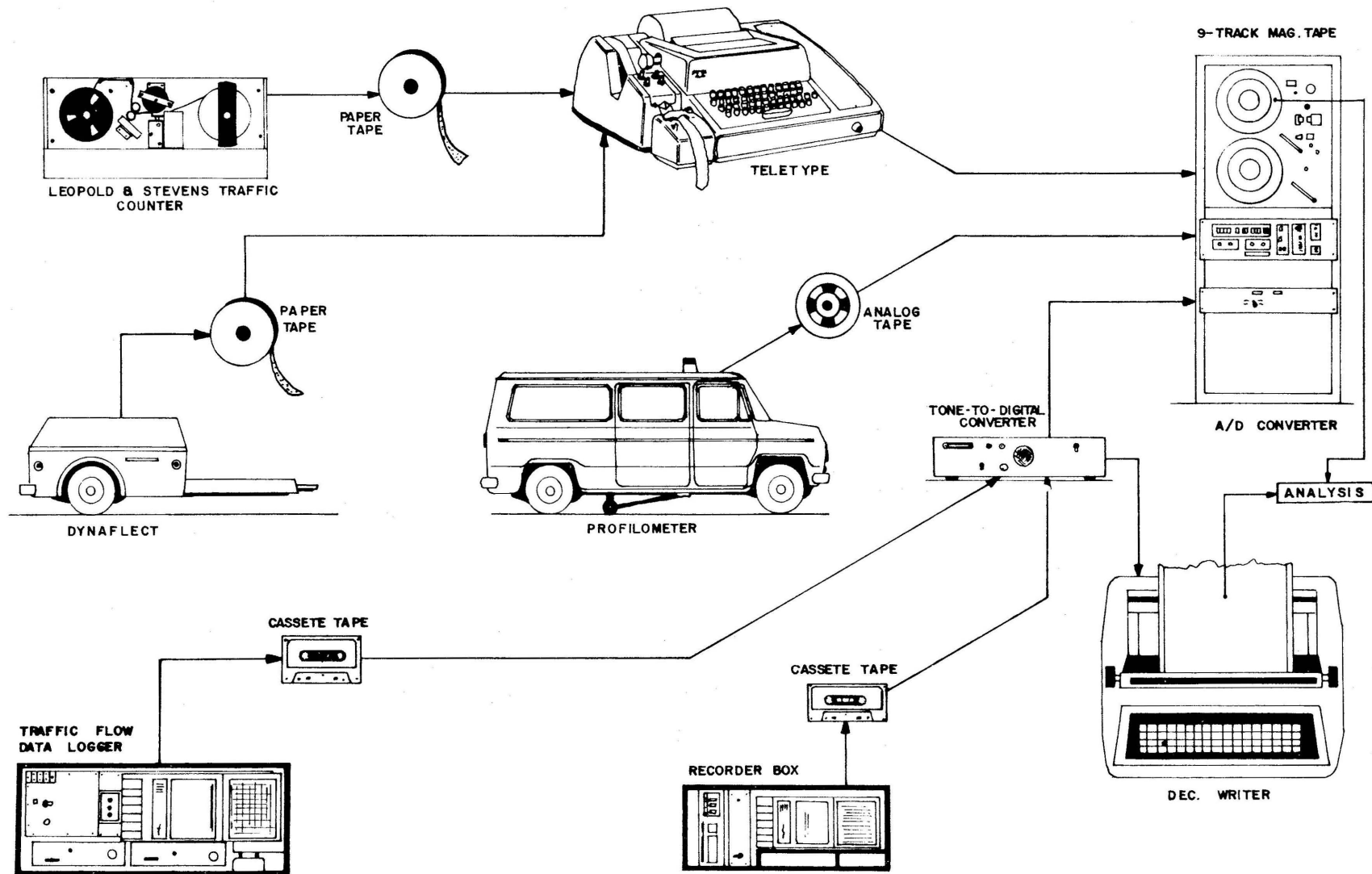

FIGURE 9.1 - DATA CONVERSION EQUIPMENT

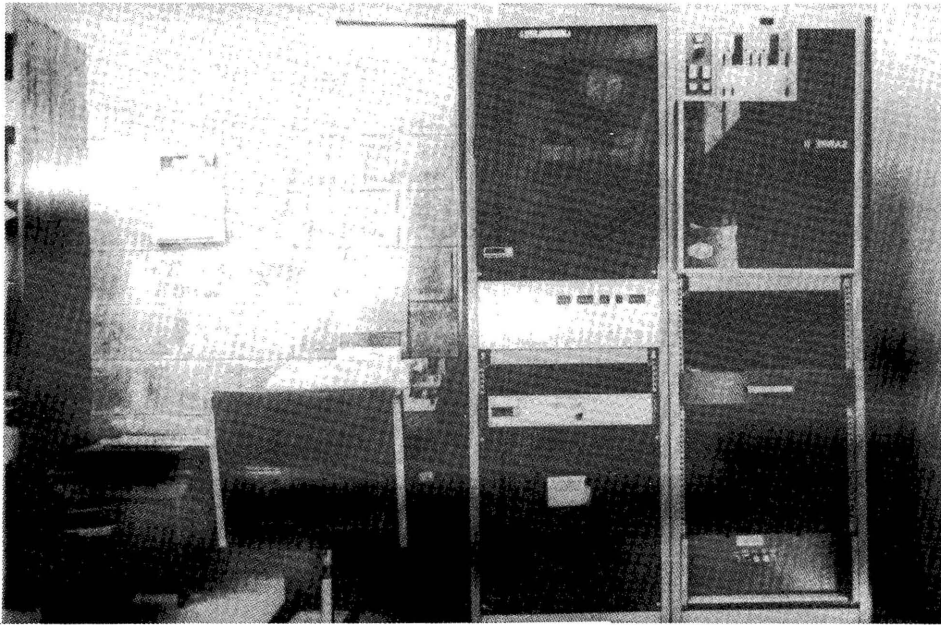

FIGURE 9.2 - A/D CONVERTER

Instrumentation Group and is described in a Project Instrumentation Memo (Linder, "Tone-to-Digital Converter").

The A-to-D also accepts punched paper tape via the teletype machine. In this mode of operation, a header record containing identifying information may be added to each magnetic tape file. Limited editing features were also included in this mode.

### 9.3 FIELD OPERATION

The main purpose of the A-to-D was to convert the analog road profile data from the Profilometer to a digital magnetic tape form for automatic entry into a digital computer for analysis. In this mode the SANGAM tape recorder is played into a set of two digital converters which convert the profiles to digital form. The control unit then formats the data and transfers it to the 9-track tape transport.

The Tone-to-Digital converter was also used to convert the cassette tapes of the recorder box to a teletype-like format of 300 Baud rate for entry into the Digital Equipment Corporation printer. The printer format is contained on the cassette so a simple slave-type printer with a 300 Baud speed is adequate.

The Bell and Howell and Kodak projectors were used to display the output of the camera boxes on a viewing screen one frame at a time so that a clerk could copy the DMI and stopwatch reading on a coding form.

### 9.4 MAINTENANCE

There were problems with the A-to-D converter on several occasions. It was initially suspected that some problems had been caused by instable power delivery by the power company. Thus a voltage stabilizer was installed and special grounding was provided. However, the same problems reappeared with the equipment from time to time, until the end of the project. It was not possible to find the real cause of the problems, since they were intermitent. The equipment documentation (schematics, etc.) furnished by the manufacturer, Texas Microsystems, INC., was very badly presented and incomplete. Problems in the micro-

software of the converter were found and the manufacturer contacted. New EPROM memories sent by the manufacturer did not solve the problems.

The SANGAMO tape recorder suffered the same problems as those of the Profilometer mounted recorder, described earlier in Chapter 2.

The teletype machine and the Tone-to-Digital converter were maintenance-free. The Digital Equipment Corporation printer suffered a broken sprocket wheel which was repaired by gluing the wheel back together.

The Kodak projectors were manufactured for the home entertainment market and not intended to be used 40 hours a week for data reduction. Consequently, they failed and required repair.

#### 9.5 RECOMMENDED REPAIR FACILITIES

One electronics engineer  
One senior electronics technician  
Oscilloscope  
Digital volt-ohm meter  
Frequency counter  
Function generator  
Hand tools



CHAPTER 10  
MEASUREMENT OF ROAD SURFACE  
CONDITIONS





## 10.1 INTRODUCTION

The four types of measurement devices used by the Pavement Group for its road surface condition surveys included a rut depth gauge, a loose material container, a skid meter and a texture meter.

## 10.2 RUT DEPTH GAUGE

The rut depth gauge is shown in Figure 10.1 and was used by the Pavement Group and the Traffic Experiments Group. The Pavement Group measured rut depth as a performance parameter of paved and unpaved roads. The Traffic Experiments Group measured rut depth to evaluate its influence on vehicle speed and fuel consumption.

Four gauges were used during the research. The prototype was constructed at a local machine shop. The Instrumentation Group produced the other three in its own workshop. Construction details for the gauge are covered in a Project Instrumentation Memo (Buller, "Rut Depth Gauge").

The instrument consists of a triangular aluminum frame with a graduated aluminum or steel bar which slides vertically through the center of the frame.

Scale accuracy is ensured by using a steel rule recessed into the sliding bar. The scale has a range of 0-30 centimeters and can be read to the nearest millimeter. The base length is 1.10 meter.

Figure 10.2 shows a cross-sectional view of the device on a road. Figure 10.4 is an actual example of its use. The device was made in two sizes since the original instrument was too large to be carried in small cars.

## 10.3 LOOSE MATERIAL SAMPLING DEVICE

The equipment used to measure gravel looseness is shown in Figure 10.3. It includes a rectangular steel angle frame, which was used to define the area from which loose material was to be collected,

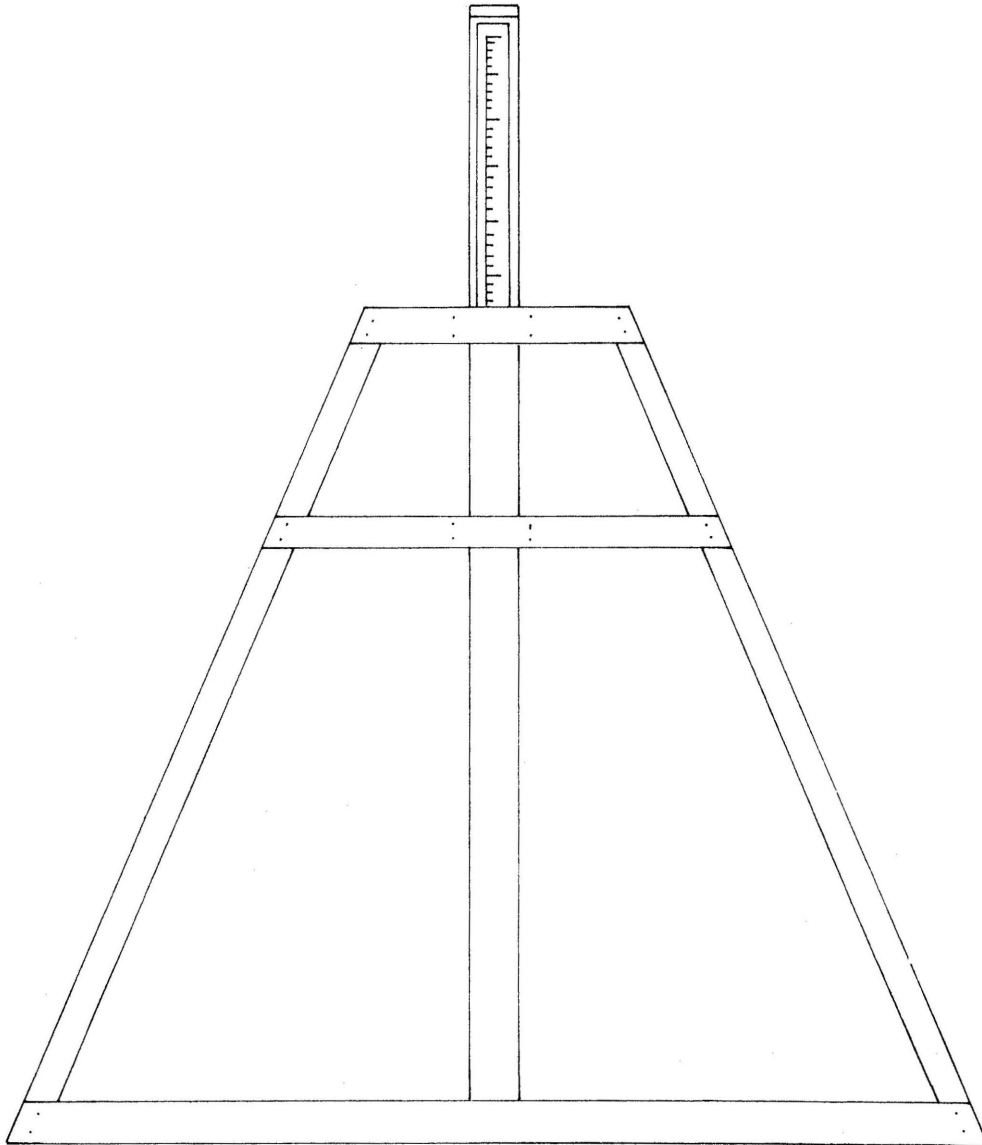

FIGURE 10.1 - RUT DEPTH GAUGE

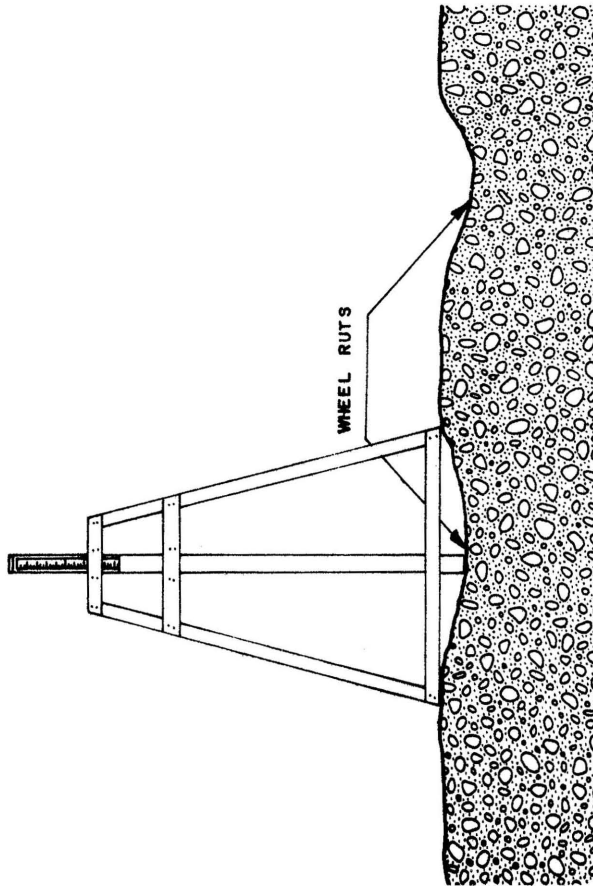

FIGURE 10.2 - RUT DEPTH GAUGE IN OPERATION

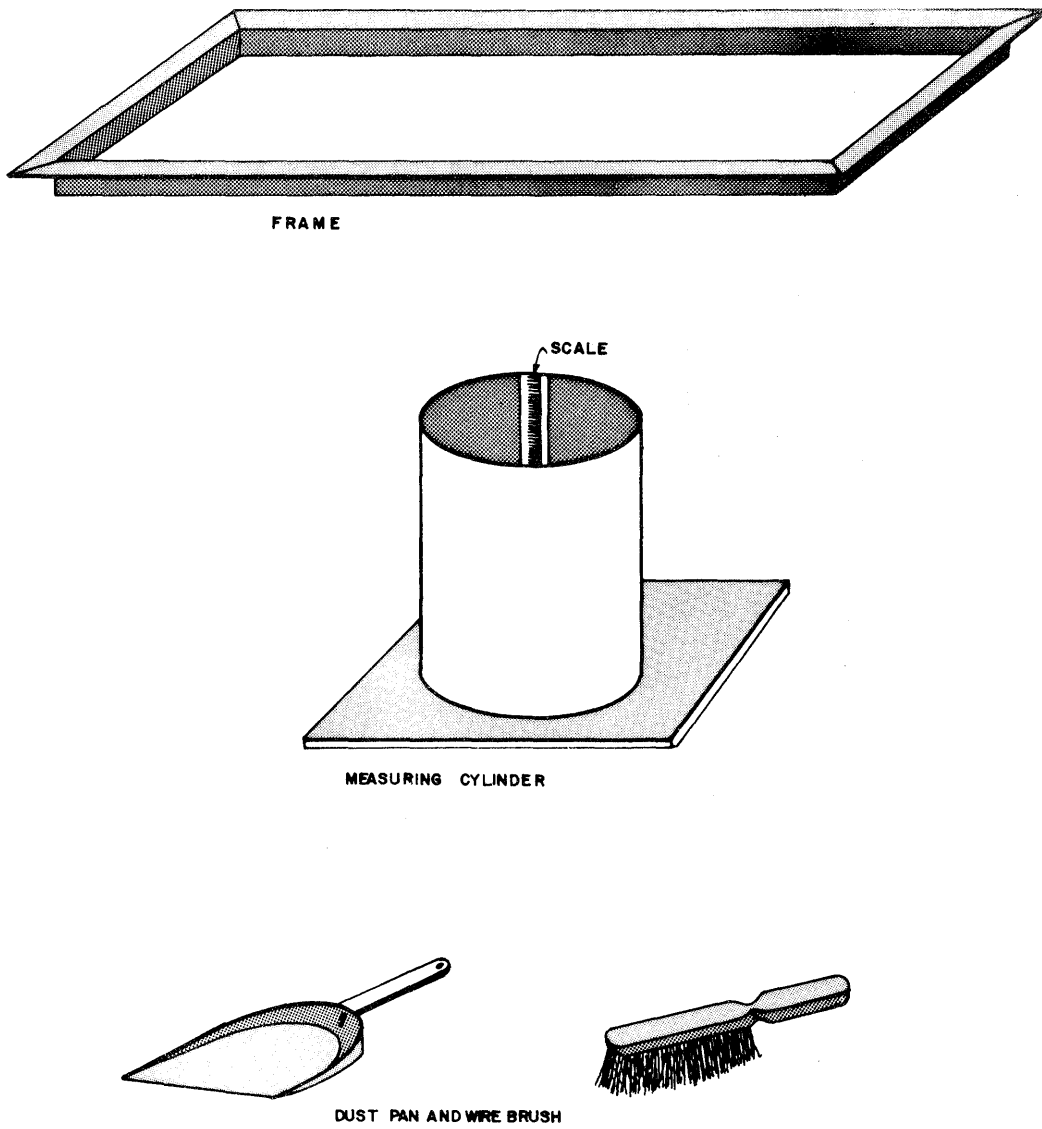

FIGURE 10.3 - LOOSE MATERIAL SAMPLER

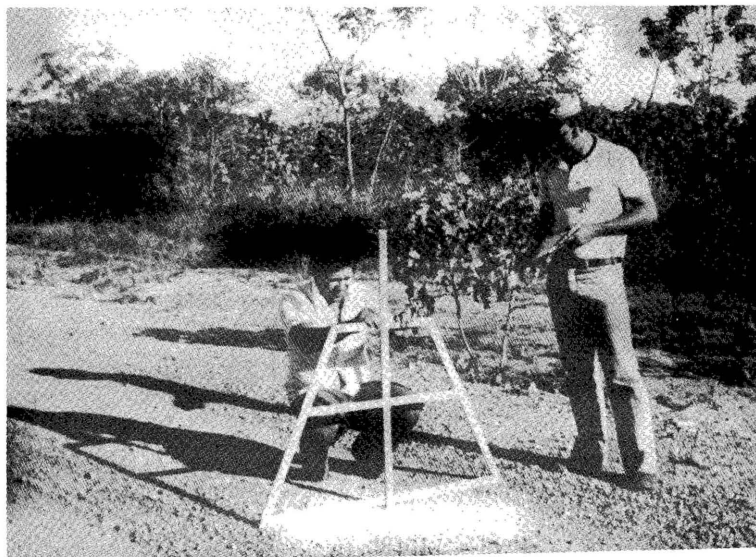

FIGURE 10.4 - TECHNICIANS MEASURING RUT DEPTH AND GRAVEL LOOSENESS ON AN UNPAVED ROAD

a measuring cylinder and a small household-type dust pan and brush. The frame and measuring cylinder were constructed in a local machine shop. The latter two items were purchased locally. Figure 10.4 shows loose material being measured in the field.

#### 10.4 SKID RESISTANCE TESTER

The skid resistance tester model Mark IV, manufactured by DIE-A-MATIC, INC., was used by the Pavement Group to study the skid resistance of selected road sections in the Federal District of Brazil. The results from these tests are presented in a Project Technical Memo (Visser, Technical Memo No. 22/76).

Only one of these instruments was purchased for project use. It received limited usage and required no maintenance.

The instrument was developed for quick checks of skid resistance at selected spots and is illustrated in Figure 10.5. The tester measures the drag force developed between a rubber-heeled shoe and a wet surface at low sliding speeds. Since the former is proportional to the skid resistance of automotive tires, the tester permits the relative rating of a pavement's skidding potential.

The unit is pushed by its operator at a brisk and uniform pace over a wet pavement. The drag force acting on the rubber shoe is converted into a proportional hydraulic signal and displayed by the indicator shown in Figure 10.6.

#### 10.5 TEXT-UR-METER

The texture meter, shown in Figures 10.7 and 10.8, was used to measure the textural roughness of the pavement surface in vehicle wheel paths. It is manufactured by the Rainhart Company. Only one unit was purchased for project use.

The Pavement Group used this instrument in conjunction with the skid tester to study textural properties of roads in the Federal District.

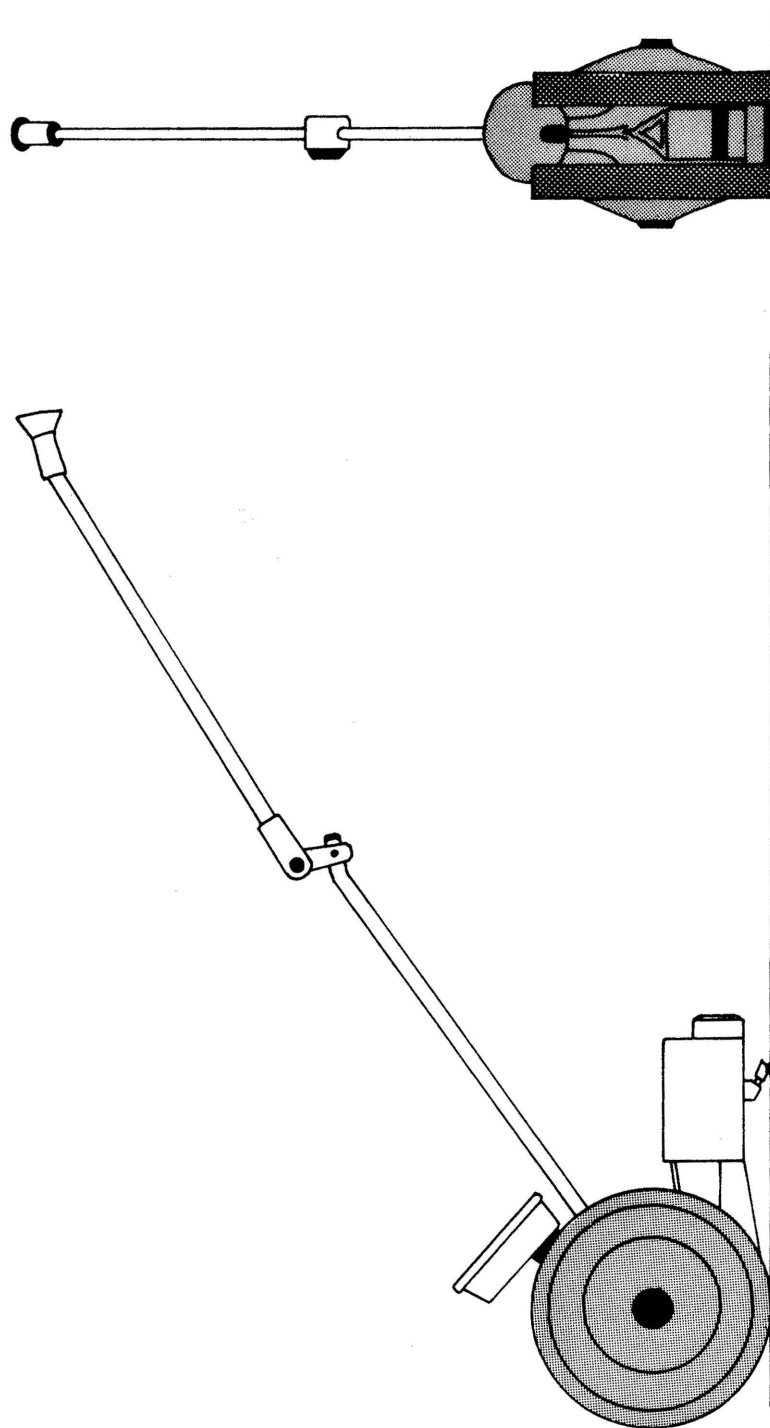

FIGURE 10.5 - SKID-RESISTANCE TESTER

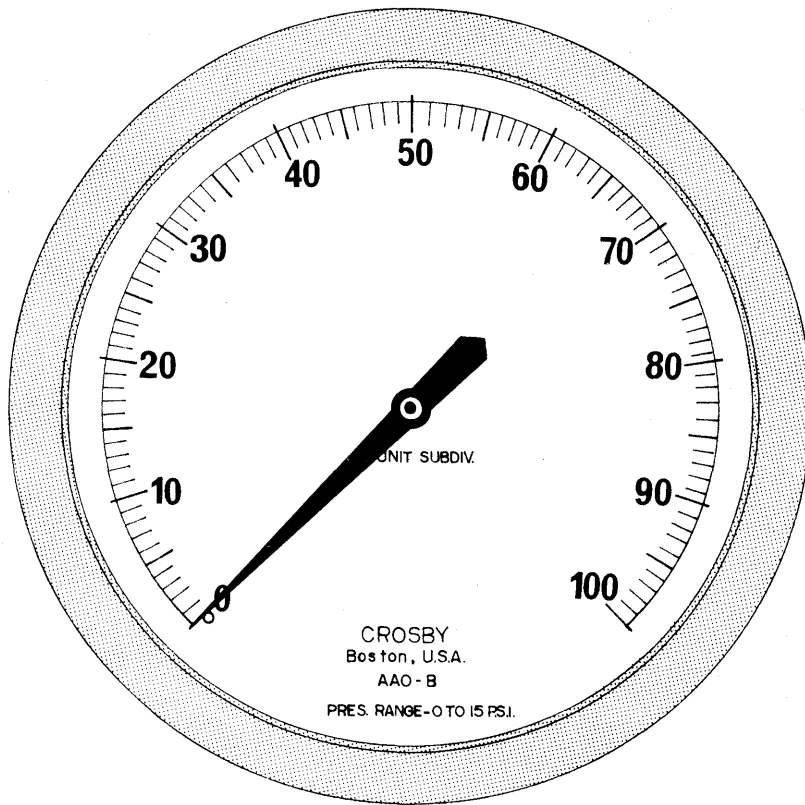

FIGURE 10.6 - INDICATOR OF SKID TESTER



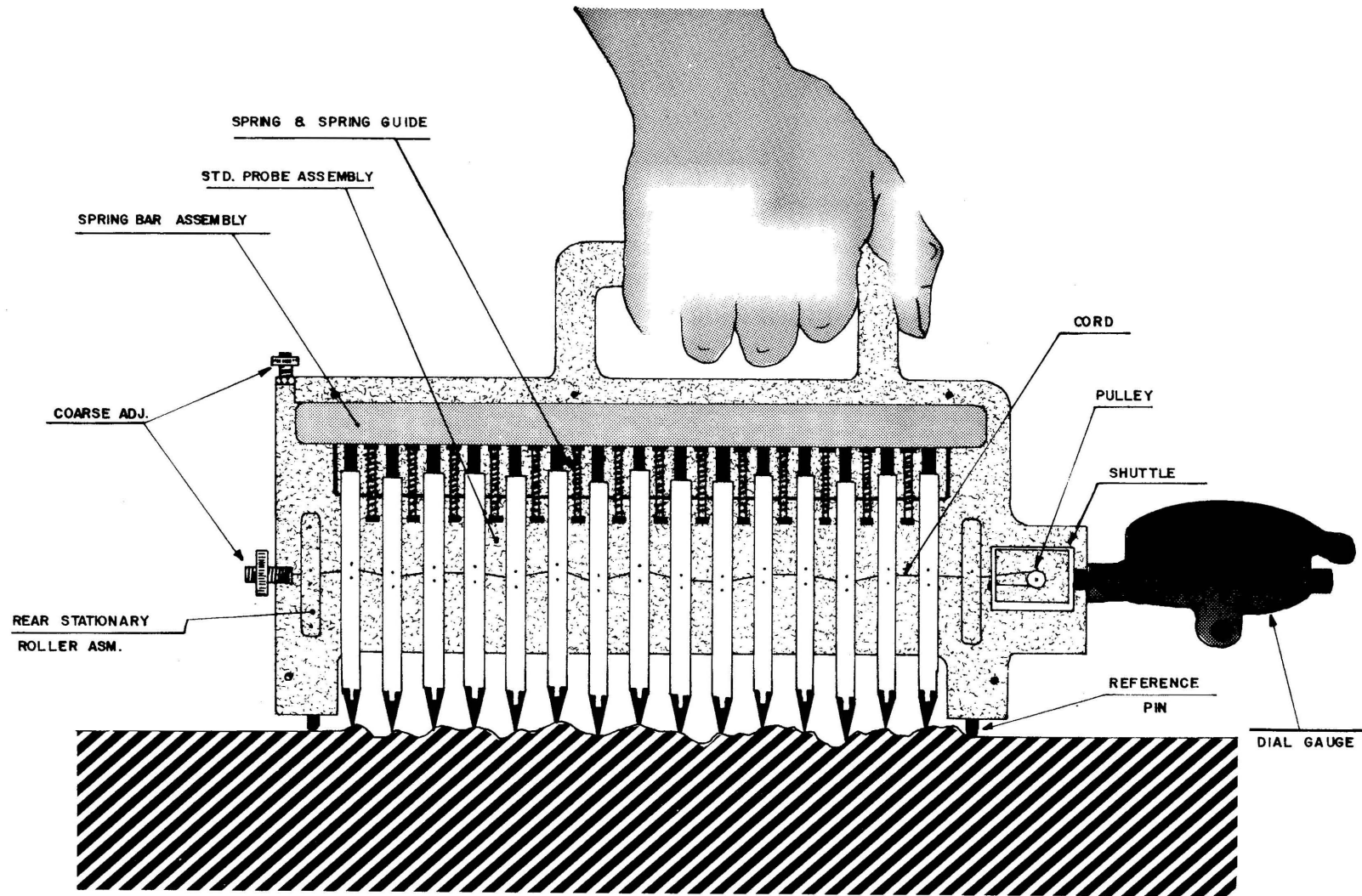

FIGURE 10.7 - TEXT-UR-METER



FIGURE 10.8 - TEXT-UR-METER IN USE

The Text-Ur-Meter is an apparatus which measures the macro-texture of a surface by means of a dial gauge attached to a string that passes through 29 pointers along the profile of the surface. For additional information consult the manufacturer's literature.



CHAPTER 11  
METEOROLOGICAL MEASUREMENTS



## 11.1 INTRODUCTION

Two types of meteorological measurements were required: rainfall and wind velocity. The rainfall measurements were used by the Pavement Group to evaluate the effects of rainfall on road deterioration. The wind velocity measurements were required for the fuel consumption studies.

## 11.2 RAIN GAUGE

Two types of rain gauges were used. One was a simple graduated plastic pot as shown in Figure 11.1. It is made of clear plastic sheets which are joined with plastic cement. The design permits mounting with nails or screws to a post, or inserting the strengthened spade into the soil. It has no moving parts and, apart from cleaning, needs no maintenance. The amount of rainfall is read from a dual scale molded in the front face of the device. Graduations are in both inches and millimeters. Its resolution is to one-tenth of an inch with a range of 5 inches. This device is a simple accumulator. To obtain rainfall data it must be read periodically and at appropriate times.

The second type of rain gauge is pictured in Figure 11.2 and it is manufactured by Texas Electronics, INC. Two of these devices were used. They consist of a rainfall sensor, which works as a tipping bucket, connected to an electrical accumulator, fitted with a paper chart recorder. The chart recorder paper is driven at a given number of centimeters per hour. Therefore, the amount of rainfall occurring at any time of day or night, over a period of months, may be determined by reading the chart recording. The resolution is to one-tenth of an inch with a range extending to infinity because the chart recorder goes from zero to ten inches and back to zero to start over again.

This unit was designed for a power source of 110 volts, 50Hz. It was necessary to place the unit in remote locations where power was not always available. Therefore, the Instrumentation Group constructed small inverters to power the rain gauges from 12 volt storage batteries. The inverter produces 110 V AC at 50Hz. An example of the output from the rain gauge is pictured in Figure 11.3. A more complete description of the rain gauge and the inverter are covered in a

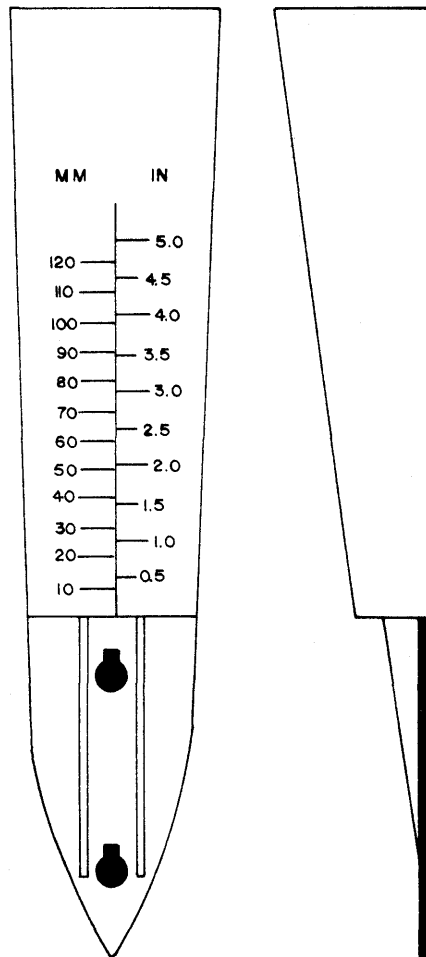

FIGURE 11.1 - PLASTIC POT RAIN GAUGE



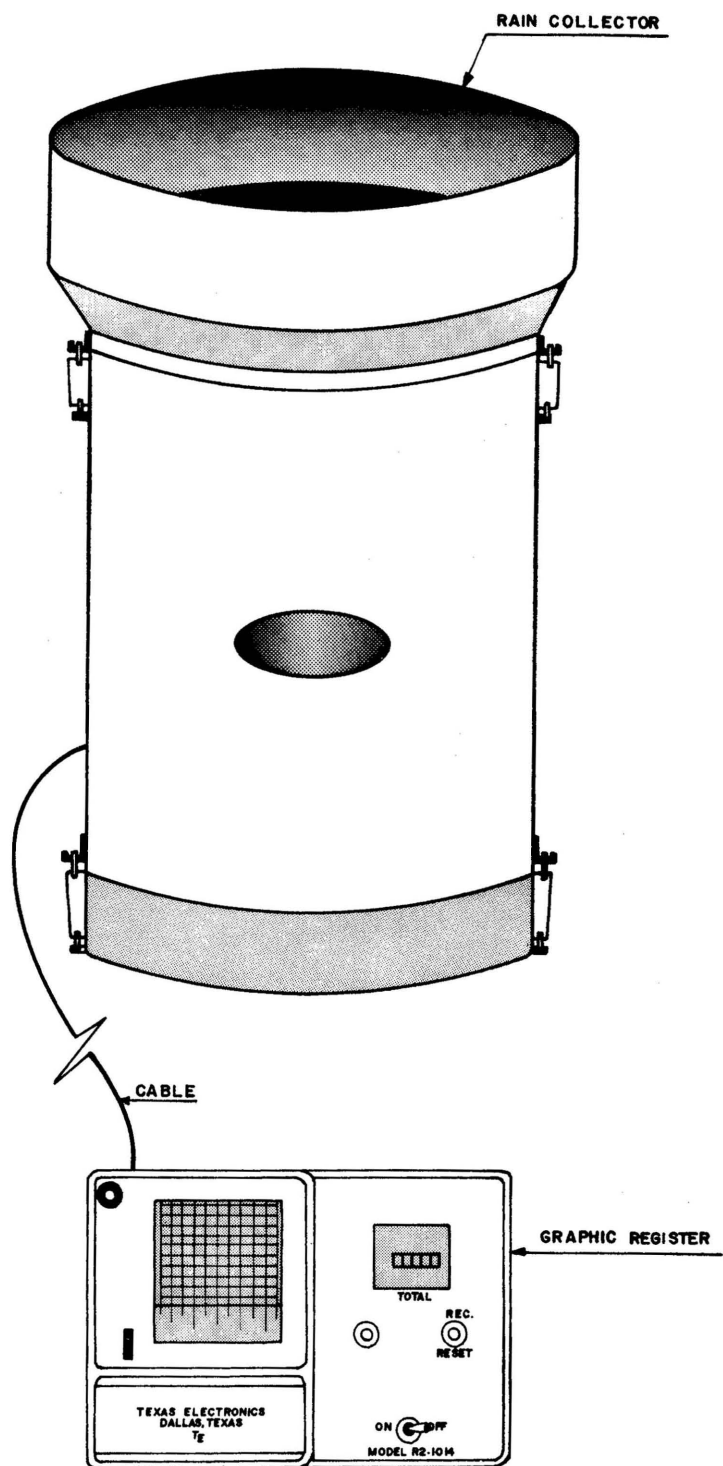

FIGURE 11.2 - AUTOMATIC ELECTRONIC RAIN GAUGE

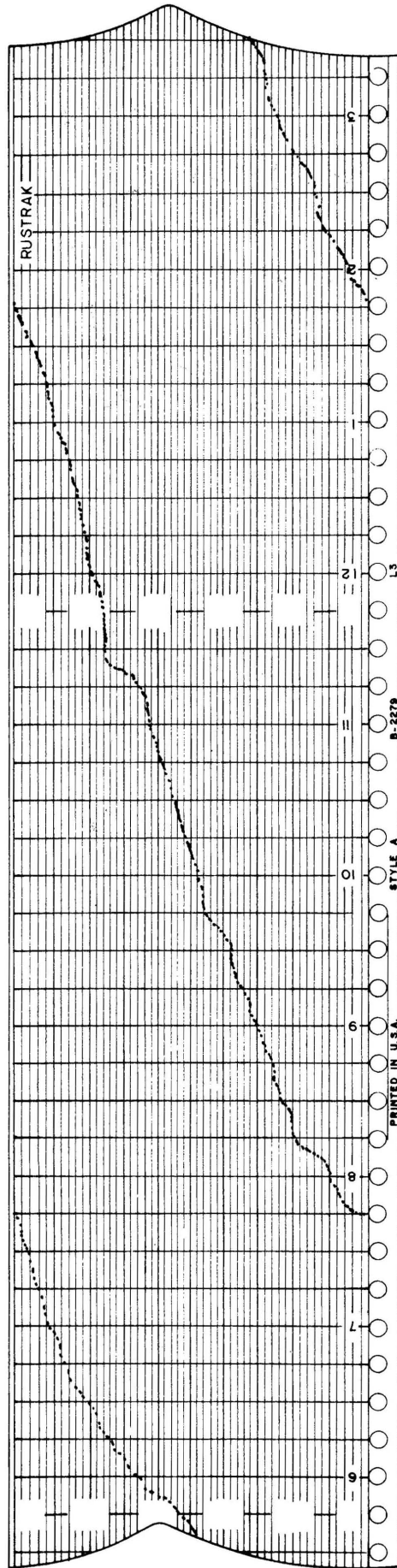

FIGURE 11.3 - RAIN GAUGE OUTPUT

Project Instrumentation Memo (Buller, "Rain Gauges").

### 11.2.1 *Maintenance*

Both recording rain gauges were damaged by careless handling. One of the recorders was damaged beyond repair when the chart recorder pointer was broken off while changing the chart paper.

The DC-to-AC inverters were temperature-sensitive and would drift from the 50Hz, causing an inaccurate drive speed for the chart paper. A potential problem was main power failure that occurred frequently during rain storms. If the instruments had been powered solely by local power, a much greater time measurement error could have been experienced.

### 11.2.2 *Recommended Maintenance Facilities*

One electronics technician  
Volt-ohm meter  
Hand tools

### 11.3 *WIND METER*

The wind speed indicator used is pictured in Figures 11.4 and 11.5. It is manufactured by Airguide Instrument Company. It is a hand-held unit which is pointed into the wind by the operator. The wind speed is read directly from the instrument dial. The manufacturer makes models reading in meters per second or miles per hour. Also, the manufacturer has available a model with a compass for determining wind direction. The project model read in miles per hour.

Despite harsh treatment, the wind meter stood up extremely well. The resolution is to one mile per hour from 5 MPH to 70 MPH. No attempt was made to check its accuracy more precisely.

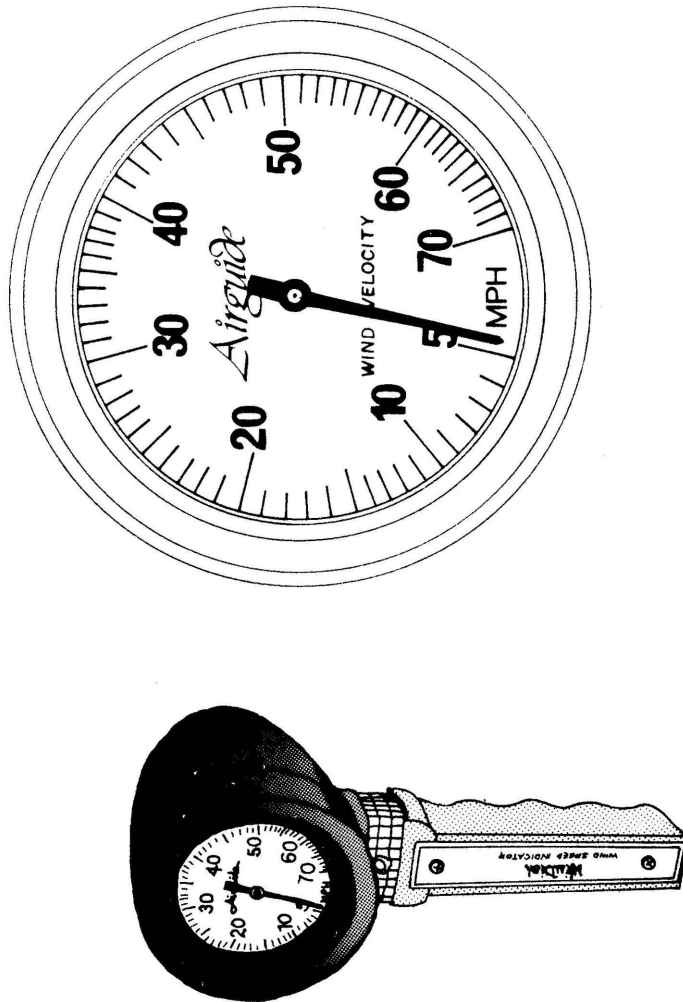

FIGURE 11.4 - WIND SPEED INDICATOR



FIGURE 11.5 - WIND METER IN USE



CHAPTER 12  
CONCLUSIONS AND RECOMMENDATIONS





The Instrumentation Group was one of the smaller study groups in terms of manpower. The basic tasks of the group were initially defined as the installation and maintenance of the imported equipment, as well as training the operators. In practice, however, more than 75% of the Group's time was dedicated to:

(a) Adaptating the equipment to the conditions of operation in Brazil. Almost every piece of imported equipment had to be adapted to some extent to work well in the PICR test environment.

(b) Design and manufacture of original equipment to cope with new requirements that arose during the project. Examples include the survey vehicle; the traffic flow data logger; the recorder box; the tone-to-digital converter; the digital output unit for the Maysmeter and the PELID.

(c) Development of so called commercial instruments which proved in practice to be only prototypes. This non-anticipated activity caused the expenditure of a high number of man-hours in work and in communications with equipment manufacturers overseas to solve design problems in apparatuses that were vital for the data collection system, like the Profilometer and the Weigh-In-Motion System.

The activities (a), (b) and (c), described above, brought difficulties, challenges and additional work that were not anticipated by the project managers at the beginning of the PICR.

It is recommended, based on the experience acquired by the Instrumentation Group, that in projects with time constraints, like the ICR Research, the purchase of instruments not completely developed and tested be avoided. If this proves impossible, it is recommended that sufficient time be allocated to testing the instruments in the environment where they are going to operate before effectively initiating the data collection process.

The Instrumentation Group documented all its work by means of technical and operational memos that contain the Group's accumulated experience during the ICR Research. These memos, together with this Volume, allow anyone interested to know which instruments are recommended and which are not, and why, for each type of measurement.



1  
REFERENCES CITED

AIRGUIDE INSTRUMENT COMPANY, 2210 Wabansia Avenue, Chicago, Illinois 60647, USA.

ALCKMIN, J. A. R. et al. Estudo Sobre a Validade dos Dados de Irregularidade da Pesquisa ICR. Brasília, Empresa Brasileira de Planejamento de Transportes. PICR, 1981 (Internal Document)

ARGO INSTRUMENTS CORPORATION, 36-21 33rd Street, Long Island City, New York 11103, USA.

BULLER, S.. Camera Boxes. ICR/SB/199/78. Instrumentation Memo No. 04/78. June 27, 1978. In: Empresa Brasileira de Planejamento de Transportes. PICR. Quarterly Progress Report No. 9. Brasília, 1978. p. 215-60; and Working Document No. 6. Brasília, 1979. p. 97-142.

\_\_\_\_\_. Camera Boxes. ICR/SB/309/78. Instrumentation (Operational) Memo No. 04/78. October 9, 1978. In: Empresa Brasileira de Planejamento de Transportes. PICR. Quarterly Progress Report No. 10. Brasília, 1978. p. 317-30; and Working Document No. 7. Brasília, 1979. p. 73-86.

\_\_\_\_\_. Instrumentation for Dust Measurements. ICR/SB/43/78. Technical Memo No. 01/78. March 8, 1978. In: Empresa Brasileira de Planejamento de Transportes. PICR. Quarterly Progress Report No. 8. Brasília, 1978. p. 70-85; and Working Document No. 11. Brasília, 1979. p. 1-16.

\_\_\_\_\_. Loose Material Sampling Device. ICR/SB/05/79. Instrumentation (Operational) Memo No. 10/79. January 5, 1979. In: Empresa Brasileira de Planejamento de Transportes. PICR. Quarterly Progress Report No. 11. Brasília, 1979. p. 85-92; and Working Document No. 6. Brasília, 1979. p. 305-12.

1

This reference list includes the names and addresses of the manufacturers cited in the text, in alphabetical order.

---

. Loose Material Sampling Device. ICR/SB/09/79. Instrumentation Memo No. 10/79. January 5, 1979. In: Empresa Brasileira de Planejamento de Transportes. PICR. Quarterly Progress Report No. 11. Brasília, 1979. p. 207-12; and Working Document No. 7. Brasília, 1979. p. 227-32.

---

. Photo Electric Light Intensity Detector (PELID). ICR/SB/201/78. Instrumentation Memo No. 001/78. May 5, 1978. In: Empresa Brasileira de Planejamento de Transportes. PICR. Quarterly Progress Report No. 9. Brasília, 1978. p. 139-65; and Working Document No. 6. Brasília, 1979, p. 1-36.

---

. Photo Electric Light Intensity Detector (PELID). ICR/SB/306/78. Instrumentation (Operational) Memo No. 001/78. October 9, 1978. In: Empresa Brasileira de Planejamento de Transportes. PICR. Quarterly Progress Report No. 10. Brasília, 1978. p. 251-70; and Working Document No. 7. Brasília, 1979. p. 1-20.

---

. Photographic Equipment. ICR/SB/311/78. Instrumentation (Operational) Memo No. 006/78. October 9, 1978. In: Empresa Brasileira de Planejamento de Transportes. PICR. Quarterly Progress Report No. 10. Brasília, 1978. p. 345-62; and Working Document No. 7. Brasília, 1979. p. 115-32.

---

. Portable Wheel-Load Weigher. ICR/SB/003/79. Instrumentation Memo No. 008/79. January 5, 1979. In: Empresa Brasileira de Planejamento de Transportes. PICR. Quarterly Progress Report No. 11. Brasília, 1979. p. 67-77; and Working Document No. 6. Brasília, 1979. p. 281-91.

---

. Portable Wheel-Load Weigher. ICR/SB/007/79. Instrumentation (Operational) Memo No. 008/79. January 5, 1979. In: Empresa Brasileira de Planejamento de Transportes. PICR. Quarterly Progress Report No. 11. Brasília, 1979. p. 176-99; and Working Document No. 7. Brasília, 1979. p. 191-214.

---

. Rain Gauges. ICR/SB/198/78. Instrumentation Memo No. 002/78. May 10, 1978. In: Empresa Brasileira de Planejamento de Transportes. PICR. Quarterly Progress Report No. 9. Brasília, 1978. p. 167-75; and Working Document No. 6. Brasília, 1979. p. 39-49.

- \_\_\_\_\_ . Rain Gauges. ICR/SB/307/78. Instrumentation (Operational) Memo No. 002/78. October 9, 1978. In: Empresa Brasileira de Planejamento de Transportes. PICR. Quarterly Progress Report No. 10. Brasília, 1978. p. 271-190; and Working Document No. 7. Brasília, 1979. p. 23-42.
- \_\_\_\_\_ . Reservoir Fuel Meters. ICR/SB/202/78. Instrumentation Memo No. 005/78. June 28, 1978. In: Empresa Brasileira de Planejamento de Transportes. PICR. Quarterly Progress Report No. 9. Brasília, 1978. p. 261-80; and Working Document No. 6. Brasília, 1979. p. 145-64.
- \_\_\_\_\_ . Rut Depth Gauge. ICR/SB/004/79. Instrumentation Memo No. 009/79. January 5, 1979. In: Empresa Brasileira de Planejamento de Transportes. PICR. Quarterly Progress Report No. 11. Brasília, 1979. p. 78-84; and Working Document No. 6. Brasília, 1979. p. 295-301.
- \_\_\_\_\_ . Rut Depth Gauge. ICR/SB/08/79. Instrumentation (Operational) Memo No. 009/79. January 5, 1979. In: Empresa Brasileira de Planejamento de Transportes. PICR. Quarterly Progress Report No. 11. Brasília, 1979. p. 200-6; and Working Document No. 7. Brasília, 1979. p. 217-23.
- \_\_\_\_\_ . Weigh-In-Motion Installation. ICR/SB/333/77. Technical Memo No. 013/77. November 17, 1977. In: Empresa Brasileira de Planejamento de Transportes. PICR. Quarterly Progress Report No. 7. Brasília, 1978. p. 80-107; and Working Document No. 5. Brasília, 1978. p. 339-66.
- \_\_\_\_\_ . Weigh-In-Motion System. ICR/SB/305/78. Instrumentation Memo No. 007/78. October 9, 1978. In: Empresa Brasileira de Planejamento de Transportes. PICR. Quarterly Progress Report No. 10. Brasília, 1978. p. 160-250; and Working Document No. 6. Brasília, 1979. p. 187-247.
- \_\_\_\_\_ . The Weigh-In-Motion System. ICR/SB/312/78. Instrumentation (Operational) Memo No. 007/78. October 9, 1978. In: Empresa Brasileira de Planejamento de Transportes. PICR. Quarterly Progress Report No. 10. Brasília, 1978. p. 363-415; and Working Document No. 7. Brasília, 1979. p. 135-87.

- \_\_\_\_\_ . Workshops. ICR/SB/304/78. Instrumentation Memo No. 006/78. October 9, 1978. In: Empresa Brasileira de Planejamento de Transportes. PICR. Quarterly Progress Report No. 10. Brasília, 1978. p. 143-59; and Working Document No. 6. Brasília, 1979. p. 167-83.
- BULLER, S. & LINDER, S.. Camera Boxes. ICR/SB/SL/369/77. Technical Memo No. 17/77. December 20, 1977. In: Empresa Brasileira de Planejamento de Transportes. PICR. Quarterly Progress Report No. 7. Brasília, 1978. p. 140-63; and Working Document No. 5. Brasília, 1978. p. 409-32.
- \_\_\_\_\_ . Fuel Measurement System Using the Reservoir Fuel Meter and the DMI. ICR/SB/SL/310/78. Instrumentation (Operational) Memo No. 005/78. October 9, 1978. In: Empresa Brasileira de Planejamento de Transportes. PICR. Quarterly Progress Report No. 10. Brasília, 1978. p. 331-44; and Working Document No. 7. Brasília, 1979. p. 89-112.
- \_\_\_\_\_ . Traffic Flow Data Logger. ICR/SB/SL/178/79. Instrumentation (Operational) Memo No. 15/78. June 5, 1979. In: Empresa Brasileira de Planejamento de Transportes. PICR. Working Document No. 7. Brasília, 1979. p. 359-87.
- COLUMBIA SYSTEMS COMPANY, 5805 S.E. Gladstone, P.O. Box 06298, Portland, Oregon, USA.
- THE DATA GENERAL CORPORATION, Southboro, Massachusetts, USA.
- DIE-A-MATIC, INC., York, Pennsylvania 17403, USA.
- DIGITAL EQUIPMENT CORPORATION, Maynard, Massachusetts, USA.
- EMPRESA BRASILEIRA DE PLANEJAMENTO DE TRANSPORTES-GEIPOT. Report I. Inception Report. Research Concepts and Procedures. April 1976. Brasília, 1976. 158 p. Portuguese translation.
- \_\_\_\_\_ . Report II. Midterm Report. Preliminary Results and Analyses. August 1977. Brasília, 1977. 293 p. Portuguese translation.

- Roughness Measurement Systems. Working Document No. 10. Brasília: GEIPOT/PICR/UNDP/IBRD, 1979.
- FLUIDYNE INSTRUMENTATION, 1631 San Pablo Avenue, Oakland, California 94612, USA.
- GENERAL ELECTRODYNAMICS, 4430 Forest Lane, Garland, Texas 75040, USA.
- GILLESPIE, T. D. et al. Calibration of Response - Type Road Roughness Measuring Systems. Washington, D.C., Transportation Research Board, 1980. (NCHRP Report, 228).
- HIDE, H. et al. The Kenya Road Transport Cost Study: Research on Vehicle Operating Costs. Crowthorne, Transport and Road Research Laboratory, 1975. (TRRL Report LR 672).
- HODGES, J. W. et al. The Kenya Road Transport Cost Study: Research on Road Deterioration. Crowthorne, Transport and Road Research Laboratory, 1975. (TRRL Report LR 673).
- K. J. LAW ENGINEERS INC., 23660 Research Drive, Farmington Hills, Michigan 48024, USA.
- KAESEHAGEN, R. & MOSER, B. K.. Model to Simulate the Flow of Traffic (SOFOT). ICR/RK/BM/385/76. Technical Memo No. 14/76. September 23, 1976. In: Empresa Brasileira de Planejamento de Transportes. PICR. Quarterly Progress Report No. 2. Brasília, 1976; and Working Document No. 4. Brasília, 1977. p. 253-76.
- KAESEHAGEN, R. et al. Pilot Report on the Operation of Fuel Consumption Test Vehicles. ICR/RK/JZ/256/76. Technical Memo No. 005/76. July 2, 1976. In: Empresa Brasileira de Planejamento de Transportes. PICR. Quarterly Progress Report No. 1. Brasília, 1976; and Working Document No. 4. Brasília, 1977. p. 85-114.
- KUSTOM SIGNALS, 1010 West Chestnut, Charute, Kansas, USA.
- LINDER, S.. Accelerometer Based Grade Meter. ICR/SL/101/79. Instrumentation Memo No. 14/79. April 5, 1979. In: Empresa Brasileira de Planejamento de Transportes. PICR. Quarterly Progress Report No. 12. Brasília, 1979; and Working Document No. 6. Brasília, 1979. p. 579-91.

---

. Construction Details of the Digital Readout for the Mays-Ride-Meter. ICR/SL/274/77. Technical Memo No. 011/77. September 14, 1977. In: Empresa Brasileira de Planejamento de Transportes. PICR. Quarterly Progress Report No. 6. Brasília, 1977. p. 53-138; and Working Document No. 5. Brasília, 1978. p. 199-284.

---

. Digital Readout for the Mays-Ride-Meter. ICR/SL/006/79. Instrumentation Memo No. 11/79. January 5, 1979. In: Empresa Brasileira de Planejamento de Transportes. PICR. Quarterly Progress Report No. 11. Brasília, 1979. p. 93-175; and Working Document No. 6. Brasília, 1979. p. 315-97.

---

. Digital Readout Mays-Ride-Meter System. ICR/SL/10/79. Instrumentation (Operational) Memo No. 11/79. January 5, 1979. In: Empresa Brasileira de Planejamento de Transportes. PICR. Quarterly Progress Report No. 11. Brasília, 1979. p. 213-34; and Working Document No. 7. Brasília, 1979. p. 235-56.

---

. Directional Gyro. ICR/SL/102/79. Instrumentation Memo No. 15/79. April 5, 1979. In: Empresa Brasileira de Planejamento de Transportes. PICR. Quarterly Progress Report No. 12. Brasília, 1979. p. 273-80; and Working Document No. 6. Brasília, 1979. p. 505-601.

---

. Distance Measurement Instrument Circuit Description. ICR/SL/345/77. Technical Memo No. 014/77. November 24, 1977. In: Empresa Brasileira de Planejamento de Transportes. PICR. Quarterly Progress Report No. 7. Brasília, 1978. p. 108-23; and Working Document No. 5. Brasília, 1978. p. 369-84.

---

. Distance Measurement Instrument (DMI) Circuit Description. ICR/SL/100/79. Instrumentation Memo No. 013/79. April 5, 1979. In: Empresa Brasileira de Planejamento de Transportes. PICR. Quarterly Progress Report No. 12. Brasília, 1979. p. 241-59; and Working Document No. 6. Brasília, 1979. p. 557-75.

---

. Recorder Box. ICR/SL/165/79. Instrumentation Memo No. 17/79. May 30, 1979. In: Empresa Brasileira de Planejamento de Transportes. PICR. Quarterly Progress Report No. 12. Brasília, 1979. p. 294-335; and Working Document No. 6. Brasília, 1979. p. 621-36.



- \_\_\_\_\_. Recorder Box. ICR/SL/167/79. Instrumentation (operational) Memo No. 14/79. May 30, 1979. In: Empresa Brasileira de Planejamento de Transportes. PICR. Working Document No. 7. Brasília, 1979. p. 345-55.
- \_\_\_\_\_. Road Survey System. ICR/SL/98/79. Instrumentation (Operational) Memo No. 12/79. March 7, 1979. In: Empresa Brasileira de Planejamento de Transportes. PICR. Quarterly Progress Report No. 12. Brasília, 1979. p. 294-335; and Working Document No. 7. Brasília, 1979. p. 259-300.
- \_\_\_\_\_. Tone to Digital Converter. ICR/SL/103/79. Instrumentation Memo No. 16/79. April 5, 1979. In: Empresa Brasileira de Planejamento de Transportes. PICR. Quarterly Progress Report No. 12. Brasília, 1979. p. 281-93; and Working Document No. 6. Brasília, 1979. p. 605-17.
- \_\_\_\_\_. Traffic Flow Data Logger. ICR/SL/99/79. Instrumentation Memo No. 12/79. April 5, 1979. In: Empresa Brasileira de Planejamento de Transportes. PICR. Quarterly Progress Report No. 12. Brasília, 1979. p. 88-240; and Working Document No. 6. Brasília, 1979. p. 401-553.
- LINDER, S. et al. Design and Operation of the Instrumented Survey Vehicles. ICR/SL/AV/JZ/192/77. Technical Memo No. 006/77. July 8, 1977. In: Empresa Brasileira de Planejamento de Transportes. PICR. Quarterly Progress Report No. 5. Brasília, 1977. p. 78-102; and Working Document No. 5. Brasília, 1978. p. 99-123.
- MOAVENZADEH, F. et al. Highway Design Study Phase I: The Model. Washington, D.C., International Bank for Reconstruction and Development, 1971. (Working Paper) (Unpublished).
- NU-METRICS, P.O.BOX 800, 2714 Memorial Blvd. Connellsville, PA 15425, USA.
- QUEIROZ, C. A. V. de. Performance Prediction Models for Pavement Management in Brazil. Brasília, Empresa Brasileira de Planejamento de Transportes. PICR, 1981. Working Document No. 25. 317 p.

- QUEIROZ, C. A. V. de et al. Resultados de Deflexões Medidas com Vigas Benkelman. Brasília, Empresa Brasileira de Planejamento de Transportes. PICR, 1981. Working Document No. 21. 55p.
- RAINHART COMPANY, P.O.BOX 4533, 604 Williams Street, Austin, Texas 78765, USA.
- ROBINSON, R. et al. A Road Transport Investment Model for Developing Countries. Crowthorne, Transport and Road Research Laboratory, 1974. (TRRL Report LR 674).
- SANGAMO ELECTRIC COMPANY, P.O.BOX 3347, Springfield, Illinois 62714, USA.
- SIE, INC., Rt. 5, Box 214, Forth Worth, Texas 76126, USA.
- TEXAS ELECTRONICS INC., Box 7225, Inwood Station, Dallas, Texas 75029, USA.
- TEXAS MICROSYSTEMS INC., 3320 Bering Drive, Houston, Texas, USA.
- UNITECH INC., Austin, Texas, USA.
- VISSER, A. T. A Discussion of Skid Resistance Measured on Paved Road Sections in DF. ICR/AV/433/76. Technical Memo No. 22/76. November 16, 1976. In: Empresa Brasileira de Planejamento de Transportes. PICR. Quarterly Progress Report No. 3. Brasília, 1977. p. 124-42; and Working Document No. 4. Brasília, 1977. p. 387-405.
- VISSER, A. T. & MOSER, B. K. Pavement Performance and Maintenance Experiments. ICR/AV/BM/417/76. Technical Memo No. 21/76. October 7, 1976. In: Empresa Brasileira de Planejamento de Transportes. PICR. Quarterly Progress Report No. 3. Brasília, 1977. p. 87-123; and Working Document No. 4. Brasília, 1977. p. 349-85.
- VISSER, A. T. & QUEIROZ, C. A. V. de. Pavement Performance and Maintenance Experimental Sections. ICR/AV/260/76. Technical Memo No. 08/76. July 5, 1976. In: Empresa Brasileira de Planejamento de Transportes. PICR. Quarterly Progress Report No. 1. Brasília, 1976; and Working Document No. 4. Brasília, 1977. p. 145-50.

\_\_\_\_\_. Roughness Measurement Systems. Brasília, Empresa Brasileira de Planejamento de Transportes. PICR, 1979. Working Document No. 10. 119 p.

WALKER, R. S. & HUDSON, W. R. A Correlation Study of the Mays Road Meter with the Surface Dynamics Profilometer. Austin, University of Texas, 1973. (Report 156-1).

ZANIEWSKI, J. Fuel Meters. ICR/JZ/470/76. Technical Memo No. 23/76. December 28, 1976. In: Empresa Brasileira de Planejamento de Transportes. PICR. Quarterly Progress Report No. 3. Brasília, 1977. p. 143-64; and Working Document No. 4. Brasília, 1977. p. 407-32.





1981

VOLUME 3 - Instrumentation

ICR RESEARCH

MT-GEIPOP