

**THE QUANTITY SURVEYOR'S CONTRIBUTION IN IMPROVING FEASIBILITY OF  
THE DESIGN**

**By: Bain Arthur Fowler**

**Submitted in fulfilment of the requirements for the  
Degree of BSc (HONS) (Quantity Surveying)**

**In the faculty of Engineering, Built Environment of and Information  
Technology**

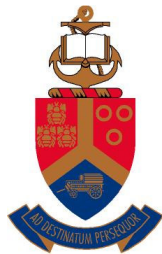

**UNIVERSITEIT VAN PRETORIA  
UNIVERSITY OF PRETORIA  
YUNIBESITHI YA PRETORIA**

**Study Leader**

**Mr. J.H. Cruywagen**

**October 2009**

**Declaration by student**

I the undersigned, hereby confirm that the attached treatise is my own work and that any sources are adequately acknowledged in the text and listed in the bibliography.

---

Signature of acceptance and confirmation by student

## **Abstract**

Title of treatise: The Quantity Surveyor's Contribution in improving feasibility of the design.

Name of Author: Mr. BA Fowler

Name of Study Leader: Mr. JH Cruywagen

Institution: Faculty of Engineering, Built Environment and Information Technology

Date: October 2009

Little is written about the influence of design on the feasibility or profitability of a construction project. Even less is known about the ability of the quantity surveyor to better the outcome.

The objective of this treatise is to investigate the influence different aspects of design have on the feasibility or profitability of a construction project. As the main aim of private developers is obtaining maximum return for their investment it is essential to minimise cost whilst maximising income. In this treatise the main design components are discussed and an attempt is made to show possible areas for improving the feasibility from the quantity surveyors perspective.

# CHAPTER 1: INTRODUCTION

---

## 1.1 OVERVIEW OF THE TOPIC

The aim of this treatise is to investigate the impact that design has on the profitability or feasibility of a construction project and to show the influence a quantity surveyor can have in the conceptual and design phases. This will not only show the importance of economical design but also the financial advantage of having a quantity surveyor on the primary design team.

An attempt will also be made to address some of the common myths associated with this reasonably unknown profession. Firstly, some recent documentation and research will be used to show some of the behind the scenes work done by a quantity surveyor when given the opportunity to deliver input during the concept design and detail design phases. Secondly, an opportunity will be given to current employers to comment on the service expected, service received and their thoughts on the proposed “new” services to be offered.

After concluding the study the aim is to show that a quantity surveyor is not only a number cruncher, cost calculator or brick counter but can, and must play an integral part during the early design phase of a project. This will also contribute to the level of success the development will achieve. Not only relating to the successful delivery of the required first year return but through value management and life cycle costing, the operating costs can be kept to a minimum thus ensuring maximum profitability for the life of the development.

## 1.2 STATEMENT OF THE MAIN PROBLEM/OBJECTIVE

What influence does design have on the profitability or feasibility of a construction project and in what manner can a quantity surveyor influence this concept?

## 1.3. STATEMENT OF THE SUB-PROBLEMS

**1.3.1. *How does architectural design influence the feasibility of a construction project?***

In this chapter an investigation will be done into how and to what extent architectural design impacts on the feasibility of a construction project. This will be shown using relevant examples of past and current projects where either the project was saved or the feasibility of the project was considerably improved through the input of a quantity surveyor.

**1.3.2. *How does structural design influence the feasibility of a construction project?***

Following the investigation into the extent of the impact of the architectural design on feasibility an investigation into the structural design and the impact thereof on the feasibility of a construction project will be done. This will also be shown using practical examples of situations where the inputs of a quantity surveyor improved on the construction cost of a building and thus improving the feasibility of the project.

**1.3.3. *How does the design of specialist services influence the feasibility of a construction project?***

As the result of soaring market conditions the current trend in the market is as such, Quantity Surveyors have limited to no time for bill preparation and are forced to proceed on provisional bills of quantities. As result of this the bills consist mostly of wet trades measured and provisional sums for specialist works and finishes. In most cases the split in value would be approximately 60/40% with the provisional sums contributing 60% of the contract value. This means that the design of the specialist services is very important and may have a considerable impact on the feasibility of such a project.

**1.3.4. *Can a quantity surveyor be a design consultant without design responsibility and how does the client and quantity surveyor relationship adapt with regards to the change in the role of the quantity surveyor?***

In all of the above situations the design consultants have design and budget responsibilities. At the initial design phases the input of an experienced quantity surveyor may greatly assist in achieving the most cost effective design. Previous experiences forms part of the arsenal of any good professional quantity surveyor even though historically their role was seen as solely being one of building cost calculation and estimation in effect a number cruncher. The quantity surveyors are dynamic, pro-active, client representatives/consultants who have much more to offer than merely cost estimation and calculation. Some of the broader services offered in life cycle costing, value management and cost engineering as a design consultant/advisor.

#### **1.4. STATEMENT OF THE HYPOTHESES**

- 1.4.1. The architectural design will most definitely have an impact on the feasibility of a project as this design gives both the General Lettable Area (GLA) and General Building Area (GBA). The ratio between these two alone can be conducive or detrimental to any development.
- 1.4.2. As the architectural design impacts on the GLA:GBA ratio, the structural design may impact greatly on the building cost of the proposed project. The method of construction and application of the chosen method will have an effect. For instance if concrete frame construction is chosen, then different permutation exist for the use of slabs with beams as to the use of flat slabs without beams.
- 1.4.3. With the provisional sums of a project contributing more than half of the contract value the economic design of such components will influence greatly the outcome of any project. The impact is often forgotten or underestimated as the detail design is mostly done during the run of the project. If sufficient care is not given during budgeting design and tender of these items the budget overruns may cause a reduced return and influence the final success of the project.
- 1.4.4. Yes, the quantity surveyor can be seen as a design consultant. Maybe not a consultant as such but definitely as an advisor. Giving COST ADVICE to his employer and any design consultant involved with the construction project. The perception of the role of a quantity surveyor greatly influences the relationship between the quantity surveyor and the client/employer. If the client gives the quantity surveyor sufficient support and authority, the quantity surveyor can contribute considerably through all of the project phases, starting with the concept design through final completion and signing of the final account.

#### **1.5. DELIMITATIONS**

The study will not compose of all commercial construction projects but will be universally applicable to a certain extent. The principles used to show the importance of the control of basic design principles used in all commercial developments. The study will be conducted primarily on commercial office block development situated in the Johannesburg and

Pretoria regions in the Gauteng province. Although the study is based on commercial office buildings this will be applicable in most respects to any commercial development as the study is based on basic design and construction principles and techniques used in all commercial developments.

#### **1.6. DEFINITION OF TERMS**

- **SAPOA**, Acronym for the South – African Property Owners Association.
- **GLA**, General let able area of a commercial development (area available for letting to prospective tenants) measured according to guidelines laid down by SAPOA.
- **GBA**, General Building Area of a commercial development (total area of building) measured according to guidelines laid down by SAPOA.
- **GLA GBA Ratio**, One of the ratios used in assessing the efficiency of the use of available space to generate an optimal income.

#### **1.7. ASSUMPTIONS**

During the study a number of assumptions will have to be made as the feasibility of a commercial construction project is reliant on some external variables outside the construction industry. One of which is the applicable prime interest rate at the time of feasibility study, this may influence the choices a developer to continue, abandon or reinvestigate his options.

Applicable Prime Interest Rate = 10.5% (2009)

Potential Interest Rate from Money Market Accounts = 8.5% (2009)

#### **1.8. IMPORTANCE OF STUDY**

This study is of critical importance for developers and quantity surveyors alike. This will show that the feasibility or rather profitability of a commercial construction development can be remarkably increased by involving a quantity surveyor at the earliest stages of concept design.

Inputs from an experienced professional quantity surveyor early on in the design may save considerable amounts of time in the latter stages of the feasibility study and decision making phases. It is also much less time consuming to make only minor changes whilst still busy with the design than later when other designers have started their design on an unprofitable

concept. Changes in the early stages can have the proverbial “Butterfly effect” when it comes to the final end result.

As time is money the little extra time and thus little extra cost spent on the initial design may save thousands in costs and even show a better return at the end of the project. Other consultants must also not see the quantity surveyor as a threat to their intended design but rather as a tool that can be implemented to achieve a more economic more efficient design.

### **1.9. RESEARCH METHODOLOGY**

Data for this essay will be collected through study of existing literature (articles, papers etc.). The majority of data will be collected from past and current projects undertaken, that clearly show the contribution a quantity surveyor can make given the early opportunity to deal with design consultants. Lastly data will be collected through interviews with practicing professionals.



# CHAPTER 2: INFLUENCE OF ARCHITECTURAL DESIGN ON FEASIBILITY OF A CONSTRUCTION PROJECT

---

## 2.1. INTRODUCTION

In this chapter the influence of architectural design on the feasibility of a construction project will be investigated. As architects tend to be more creative in nature the designs that they are responsible for is not always the most economical. The economics behind such a design will be discussed. This discussion will attempt to show some of the indicators that can be used to assess the economic efficiency of the design of an architect and also point out a few aspects that may also contribute to delivering a higher return on investment for the prospective owner of the development.

This is a very new but very important subject that has, surprisingly, little literature available. For this reason, most of the information used in this study derives from discussions with practising professional quantity surveyors.

## 2.2. THE ROLE OF AN ARCHITECT

To be able to discuss or determine what the influence of the architectural design is on the feasibility of a construction project one must first start by investigating what the role of the architect is. When looking back a few hundred years one will find that the architect was not even a recognised professional person and most commonly was also the builder of the building that he designed (Finsen, 2005). This means that he normally played a very direct role in constructing the building of his design. Often the architect was a builder, carpenter or stone mason and not the qualified graduates that fulfil this role today.

Today the architect is the main designer of the building and he also supervises the construction of such buildings of his design. He also acts as a consultant to the client and in

many cases also fulfils the role of the principal agent (Finsen, 2005). This would mean that the architect has the authority to bind the client/employer contractually in the normal delivery of his duties.

This now well known and recognised profession is governed by the Architectural Professions Act 44 of 2000. This requires by law that any person wanting to practice as a professional architect must register with the South-African Council for the Architectural Profession.

Normally the architect acts as the principal agent to the client/employer and provides all the services that the employer may need to design and construct the building. In the case of larger projects the architect may require the services of other professional persons like quantity surveyors, structural engineers and other specialist consultants (Finsen, 2005).

The key role of the architect is to co-ordinate the services and design of other consultants and advises his client on the most suitable design for his specific requirements. This will include the most appropriate construction techniques, materials etc. The next step for the architect will then be to get his design approved by all the relevant authorities which necessitates sufficient knowledge of all statutory regulations and requirements. After the approval of the design by all relevant parties the architect will supervise the construction proceedings and monitor the quality of materials and workmanship.

### **2.3. ARCHITECTURAL DESIGN PRINCIPLES**

Architectural design principles are principles used to determine the efficiency and profitability of the design by the architect. The architect is not only responsible for delivering an aesthetically pleasing building but also a building that meets the requirements and expectations set by the employer. This means that the building should not only be aesthetically pleasing but also economically viable in terms of the objective of deriving an income from the management of such property. As most commercial developers intend making profit from their developments the aesthetical appeal of the building should not overshadow the main objective of an economical development.

#### **2.3.1. OPTIMAL USE OF LAND RIGHTS AND ZONING**

When one takes a look at the heading above it is clear that developing a piece of land is not as simple as fitting a particular building onto your particular part of land. When the land is not yet owned by the employer it is essential to investigate the rights registered, to ensure that the land is fit for the intended use of the employer. For

instance land zoned for residential purpose use first needs to be rezoned for commercial use before it can be used for the development of a shopping centre or business rights need to be registered before it can be used for an office development.

If the land is already in the possession of the employer the same investigation must be done to determine the suitability of the site for the proposed development. If the correct rights and zoning restrictions are not in place alternatives can be proposed to the employer. The land can also be rezoned for the intended use but this might take time and have a direct cost and indirect cost like loss of interest.

The two most common factors to look at when investigating the use of land rights and zoning restrictions is the efficient use of the allowable site coverage and floor area ratio. Both of these factors are set by the local authorities and insufficient use if these allowances can be detrimental to the feasibility of a project.

These two factors limits the allowable size of building that may be built on the particular plot of land. The coverage of the plot of land means the total area of the land that may be covered by the development. This means that if one had a 1000m<sup>2</sup> plot of land with the restriction of a 0.5 coverage one would only be allowed 500m<sup>2</sup> of the 1000m<sup>2</sup> to be covered.

Now the implication of that is easy, the developer pays for the full 1000m<sup>2</sup> and now he can only effectively use 500m<sup>2</sup> of the plot of land to derive an income. Income will be derived from each m<sup>2</sup> that can be rented out to tenants. Now, should the designing architect not make effective use of the 0.5 coverage (500m<sup>2</sup>) and only design a building covering 400m<sup>2</sup> he would in effect offer a building with only 80% of the potential income. The impact will only arise in buildings with more than one floor as building costs rise when floors are added.

The second factor is the floor area ratio (FAR). This ratio is once again a restriction placed on a plot of land by local authorities and stipulates how much can be built on a plot of land. A good example is the one of another 1000m<sup>2</sup> plot of land. Now the floor area ratio on the land is 1500m<sup>2</sup> this means that whatever is built on this land may not exceed 1500m<sup>2</sup> in size. This once again has a major impact on the feasibility of a project if not taken into account in the design of the architect.

If the architect then designs a building not effectively using the allowed 1500m<sup>2</sup> of bulk allowed on the site he will once again deliver a building not performing to its optimum

income generating capacity. When this is the case the cost of the land remains fixed but the income derived from the tenant of the building will be way below the expected income and thus does not deliver the potential return on investment.

Both of these factors show that the business of development is effectively the “selling” of space (or like in most cases the renting out of space) now when the design does not, for whatever reason, effectively use the available space, it will deliver a less feasible or profitable development than the potential that exists if the full available area is used.

### **2.3.2. EFFICIENCY OF DESIGN**

The efficiency of design can be interpreted in many different ways. The efficiency that is of most value to this study is the economical efficiency or in other words does the development deliver an efficient income by utilising the allowed area and space. One of the most important perspectives to have is that the developer, unless he is a large corporate institution, is developing to produce an income or to create wealth. Larger corporate clients like banks developing their own head office may be willing to develop less economically to give boast stature or image of the company.

When one looks at the mechanisms available for one to assess the efficiency of a design one finds two very closely linked ratios. These ratios are used to evaluate the efficiency of the design done by the architect. The ratios take into account the Gross Building Area, Gross Lettable Area and the Useable Area.

One first must understand what each of these areas entail before looking at the application of these areas and ratios. Firstly the gross building area must be defined. Gross building area for the purpose of this study can be defined as the area constructed measured from the outer most point of the perimeter walls of each floor.

Secondly the gross lettable area is the area which the employer can effectively let or lease to tenants. This area multiplied by the rental per square meter gives the gross income for the particular development.

Lastly the usable area is the area of the building that a tenant can effectively use for the everyday run of their business. This is effectively the gross lettable area less areas that cannot be used for business which are for instance ablution facilities, foyers, lobbies, patios, etc. These are all nice to have but may make useable area extremely expensive as will be illustrated later.

Now, when one talks about the GLA:GBA ratio it is exactly as it sounds. This ratio takes the gross lettable as a ratio or percentage of gross building area. This ratio gives in effect the answer to the question “*How much of the building can be rented out to tenants?*” The closer the ratio is to 1 or the percentage is to 100% the more efficiently can the space delivered by the building be rented out. This means that more area to rent out without increasing the gross building area would mean more income without spending more on construction cost. The higher the percentage or the closer the ratio comes to 1 the more profitable the development becomes.

The next ratio flowing from the previous is the Usable Space:GLA Ratio. This ratio in return shows a tenant how much of the space he is paying for can actually be used for the everyday running of his business. This again will be a ratio or percentage. This time the closer the ratio gets to 1 or the percentage gets to 100% the more space is available for business and less space is “wasted” on other areas like balconies, ablution facilities, lobbies etc. When this ratio gets too low, the rand per m<sup>2</sup> of useable space cost, becomes too high and the employer may find it difficult to get his target rentals or his vacancies may be higher than expected.

### **2.3.3. GENERAL DESIGN**

The question of how architectural design influences the feasibility of a construction project seems to be one much debated but little written about. One could suppose it is because of the process followed to prepare the feasibility study of construction projects. In the research conducted in an article titled “*THE ECONOMICS OF ARCHITECTURE AND URBAN DESIGN: SOME PRELIMINARY FINDINGS*” (Vandal & Lane 1989) was found to be of some interest.

In this article, design as an amenity is described as the “*all over attitude towards the making of an object*”. The statement also made is that design embraces functionalism of the structure and the aesthetics of the structure.

The quality of the design can be determined by looking at the following points:

- The setting of the structure
- Shape and volume of the structure
- Articulation of the surfaces of the structure

- Configuration of the lobbies
- Selection of the hardware installed in the structure

In a study (Hough & Kratz, 1983) done on 139 office structures in Chicago it was found that the thought that higher quality office space would produce a higher rental was only partially true. The results were analysed it was found to be true for new office facilities but not for the older office space even though it also had better quality design.

According to Vandal and Lane (1989) the design can be broken up into three sub-design elements.

**Aesthetics:** Pleasure derived from looking at the outside in to the building the “external design”. Looking at internal spaces “Interior design”. And looking from the inside of the building to the outside world the “views”.

The interior spaces may play a huge role in the morale of employees that work inside the office building, whilst the exterior design may contribute to the perceived “status” of the tenant of the building.

Variations in the architectural and interior design quality could be associated or allocated to the following dimensions:

- Decorativeness or embellishment of the façade
- Colour and texture of the surface materials
- Quality of surface materials
- Differences in configuration or shape, massing fenestration also known as “volumetrics” and also the absence or presence of site amenities.(Vandal & Lane 1989)

For the purpose of this study the subdivision done by Vandal and Lane is not sufficient and needs to be further divided. This will enable this study to show a few of the design elements to be used to control or derive the required rate of return on investment.

A few of the most important general design elements to keep in mind when designing for the purpose of achieving an optimal return is:

- Size and shape of the building
- Height of the building
- Floor to ceiling height
- Grid design related to integration with the structural design
- Foyer and ablution design, finishes, accessories and fittings
- Fullness of the plan of the building
- Façade design
- Roof design
- Parking requirements and facilities
- Site characteristics

#### **2.3.3.1. SIZE AND SHAPE OF THE BUILDING**

The first element to be looked at is the size and shape of the building as this impacts on the wall to floor area ratio. This means that the shape of a building will have an effect on the economy of the design. When shapes are studied it is found that a half sphere is the shape with the best wall to floor area ratio. A sphere is also very difficult to construct and will cost much more as result of this increase in difficulty of construction.

The next best shape for a building is a square, this shape will give a much better wall to floor area ratio than a rectangle as shown in the figure bellow (Pienaar, 2004).

**Figure 1: Demonstration of the floor to wall area ratios of two different shapes of buildings. (Pienaar, 2004)**

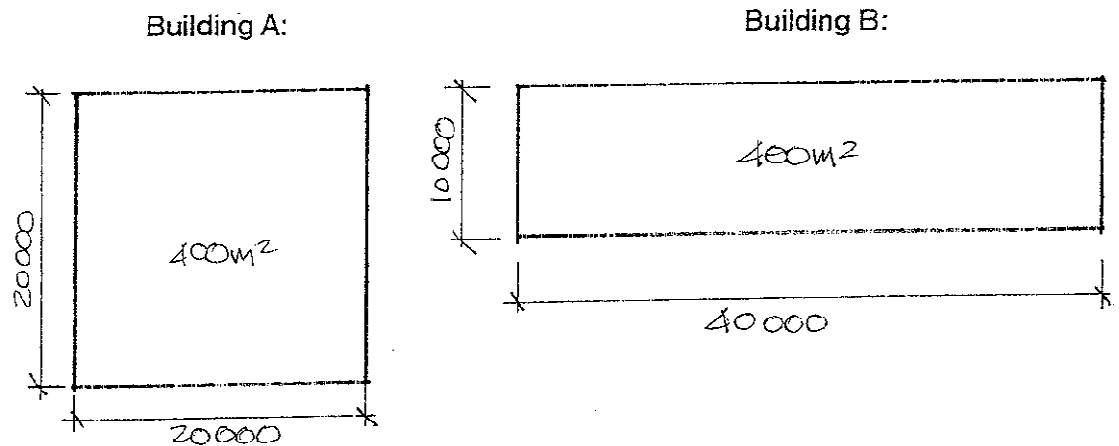

Looking at the demonstration one will find two buildings with identical floor areas (400m<sup>2</sup>). On further inspection one will see that when the lengths of the external façades are calculated one building has a longer external façade than the other. The square shaped building has a floor area of 400m<sup>2</sup> and a façade length of 20m+20m+20m+20m=80m whilst the rectangular shaped building also has a floor area of 400m<sup>2</sup> but now has a facade length of 40m+40m+10m+10m=100m (Pienaar, 2004). This extra 20 meters to the facade is very costly as the façade is usually designed as a feature and often consists of a combination of more expensive finishes.

### **2.3.3.2. HEIGHT OF THE BUILDING**

Although this impacts more on the structural design of the building it is worth mentioning it when discussing the architectural design as the height of the building will be decided by the architect and the structural engineer will have to design a safe structure to absorb all gravity, wind and other forces that the structure may face (Pienaar, 2004).

The basic principle is the higher a building becomes the more these previously mentioned forces affect the building. For the safety of the occupants and public the structural engineer will increase on his design which increases cost of the structure and thus impact the feasibility of the building.



### 2.3.3.3. FLOOR TO CEILING HEIGHT

The floor to ceiling height is the height from the finished floor level to the ceiling. This height influences area to be finished which in turn influences the construction cost (Pienaar, 2004) and thus influencing the feasibility of the project.

The severity of the impact also fluctuates with the type of wall finish that is selected by the architect. The influence of finishing will be discussed later but, the influence of floor to ceiling height can be seen in this very simple example of two situations.

Lets consider the following building which has 120 linear meters of walls and a floor to ceiling height of 2.7m. The walls are to receive one coat plaster and paint as a finish at a cost of approximately R105 per m<sup>2</sup>. Now what will the direct cost implications be on the finishing of the walls if the floor to ceiling height was to be increased to 3m?

Applicable Formulas:

$$\text{Cost} = \text{Area} \times \text{Rate}$$

$$\text{Area} = \text{Length} \times \text{Height}$$

Thus..

$$\text{Cost} = \text{Length} \times \text{Height} \times \text{Rate}$$

Situation 1: (Floor to ceiling height = 2.7m)

$$\text{Cost} = 120\text{m} \times 2.7\text{m} \times \text{R}105/\text{m}^2$$

$$= \text{R } 34\,020.00$$

Scenario 2: (Floor to ceiling height = 3m)

$$\text{Cost} = 120\text{m} \times 3\text{m} \times \text{R } 105/\text{m}^2$$

$$= \text{R } 37\,800.00$$

The conclusion of the demonstration is that in this particular case the increase of the floor to ceiling height of the building resulted in an 11.11% increase of cost.

Now should a more expensive finish be used the cost could increase even more than found in this scenario.

This simple example only shows the impact on the increase in cost of finishing the extra area. This does not even take into account the other extra costs like extra brickwork, extra concrete, formwork and reinforcement to columns etc. This only serves to show that the increase in floor to ceiling height will result in a much bigger increase in cost than can be expected and does not serve as an a calculation that can be used as an exact science but rather for demonstration purposes.

#### **2.3.3.4. GRID DESIGN RELATED TO INTERGRATION OF THE WITH THE STRUCTURAL DESIGN.**

The grid design is once again closely compelled with the structural design done by structural engineers. This seems again to be out of place under the architectural design but, one needs to understand that the structural engineer takes the building shape and size designed by the architect and then designs a safe structure to this shape and size (Fowler, 2009).

Thus, this once again emphasises the importance for economical size and shape designs from the architect.

When one has a look at past developments one will find that some shapes and dimensions are much more economical than others. In the past the tendency was to develop cellular office space and this would mean the building was designed for ease in layout of cellular offices. This has since changed as the rentals of office space increased and more people needed to be housed in less space.

This brought to the forefront the open plan office layout. Which meant that more people would now fit into the same allowed space as before by not dividing the space in to cellular offices. In many companies staff dislike the idea of no personal space but the cost effectiveness of the open plan office space makes better business sense.

This move in development of open plan areas now called for a reassessment of the adapting requirements to ensure a economical solution for the new trend. The previous requirement of cellular offices was solved with the common column

spacing of 7m and 5m (Fowler, 2009). This would have the resulting affect of two rows of 5m deep cellular offices with a 2m wide passage used for reticulation.

**Figure 2: Ideal Grid design for economic structure. (Source: Own)**

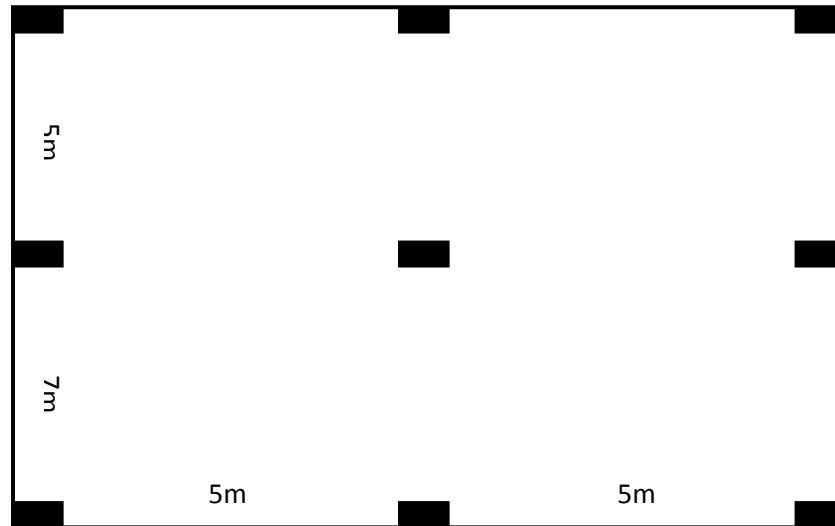

This might not be the most practical layout for the tenant but this layout will result in the most economic structure (Fowler, 2009). The variations from this grid layout will have an effect on the cost of the structure but may also influence the potential lettable area.

The more modern approach is to deliver an office with a combination of cellular and open plan spaces which can be used as open plan offices space with cellular board rooms, directors' offices, server rooms, storage space etc. The ideal layout in a situation like this would be a further development of the historical plan shown above.

**Figure 3: Ideal Grid design for economic structure of a modern grid design. (Source: Own)**

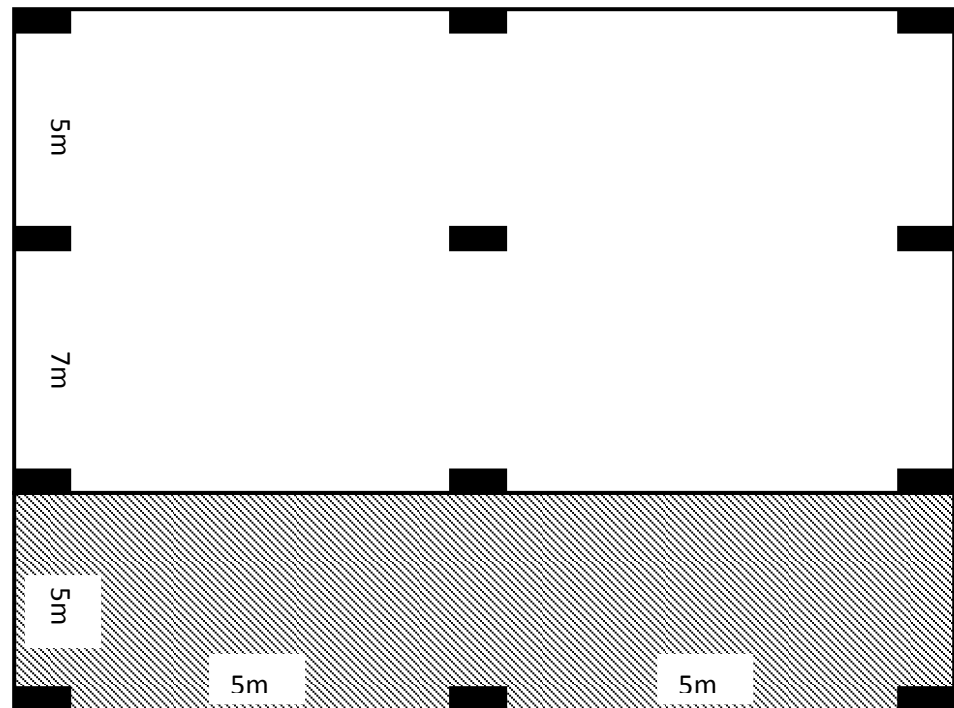

By developing the historical plan and adding the hatched area as shown above the economics of the structural design will not be compromised. This will leave the owner or tenant of the building with sufficient space to deliver two rows of cellular office space and a middle area for open space. All while the economics of the structure is not compromised.

### **2.3.3.5. FOYER AND ABLUTION DESIGN AND FINISHES**

Firstly, the design of the ablution and foyer areas must not be seen as a free standing principle as it impacts on the above discussed gross rental area to usable area ratio. These areas are also often big selling points for bigger corporate type tenants who need to convey a certain message with the status of such a corporate entity (Fowler, 2009).

When looking at the impact of the design of such areas one finds that not only the size of these areas is important but also the placement of these types of areas. Foyer areas are usually fixed to a certain area as they need to be connected with the lifts to form lift lobbies and be functional in this way. Lift shafts are often used

as strapping for the structure of the building and thus plays not only an aesthetical role but also a functional design role in the design of a building.

As the placement, usually, is fixed the only variable of the foyer or lift lobbies is the size. The size as stated earlier impacts on the usable area of the building as foyers and lobbies are expensive areas in the tenant's mind as they are not used to produce his everyday income. Once these areas become too large it might be found that the smaller non-corporate tenant will tend not to want pay the required rent for the space as they do not rely as much on the concept of status as the larger corporate businesses.

The ablution facilities are also areas that can, in many cases, be described as nice to have areas as they also do not form part of the usable space. These areas are also much higher in cost to build as they usually have expensive finishes and fittings not found in other parts of the building. These areas also need to be appropriately placed as they need duct space for the conveying of all pipe work for the provision of necessary services (water and sewage).

The finishing in these areas can become costly and may range from wallpaper and paint finishes to the more conventional floor and wall tiling. In addition to the finishes chosen for these areas are the sanitary fittings and accessories installed. These are also items that range in price and may accumulate very quickly if great care is not taken in the selection of such items.

#### **2.3.3.6. FULLNESS OF PLAN**

Firstly, one must know what the fullness of the plan of a building refers to and then understand what the impact of this concept has on the construction cost of the building. The construction cost again influences the total capital outlay required for the project and this influences the return or feasibility of the project.

Illustrated below is the basic outline drawing of the floor plan of a building with the dimensions of 30m in length and 15m width. In the first floor plan titled Building A the interior space of the building is subdivided by four 15m internal dividing walls. In the second floor plan titled Building B the floor space is subdivided by six 15m dividing walls. The floor area stays unchanged at 450m<sup>2</sup> which means that the potential income to be derived from letting the structure has not changed.

**Figure 4: Building A, a building of 450m<sup>2</sup> with 60m of internal divisions. (Pienaar, 2004)**

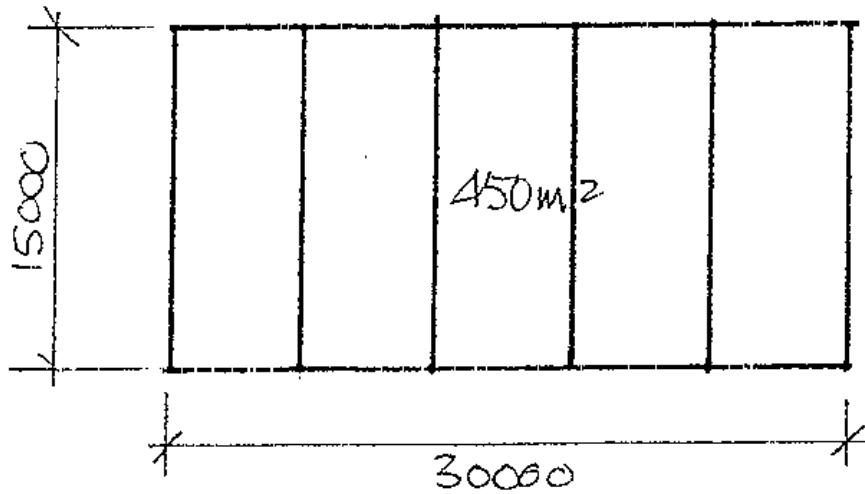

**Figure 5: Building B, a building of 450m<sup>2</sup> containing 90m of internal divisions. (Pienaar, 2004)**

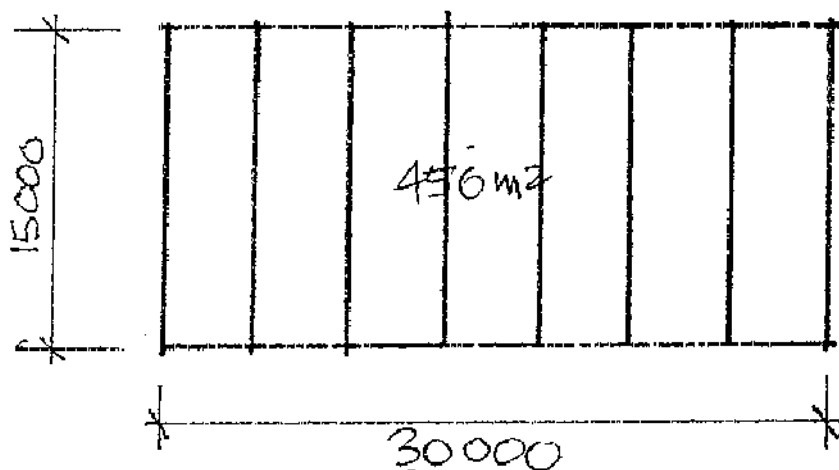

This is the case for the construction cost of the building. As was found in the discussion of the floor to ceiling height the addition of internal divisions have a severe impact on the construction cost of the building. The additional cost depends on the material used (brick walling or partition walling) for the divisions. Once again this is not the only item increasing the construction cost, one also needs to bear in mind that all of these additional divisions also need to be finished in the same manner as the existing divisions. In many cases this would mean additional plaster and paint or wall tiling or wall paper depending on the original finish chosen by the architect or internal designer.

### 2.3.3.7. FACADE DESIGN

The façade design in many cases causes some of the most stressful moments between the designers and the cost consultants. This is with good reason as this is the face of the development and anybody on the outside of the building will judge the building by its cover so to speak.

The designers might feel that this is where they need to leave their impression and in most cases this impression is expensive. In saying this it is not implied in any way that a construction project is solely an income deriving profit hungry investment with no room for decoration but, one must understand that the primary objective of most developers is income creation based on a return basis. The design of the building must under no circumstance affect the integrity of this primary objective. There might be some cases where the client or developer needs the structure to be a landmark and it is on these rare occasions where cost or return is of lesser importance.

On the other hand cost consultants must also understand that there is a fine line between money spent wisely on the aesthetics of the building (which in return helps with the letting of the space) and money wasted on expensive imported materials or huge glass façades. These are very impressive but adds little value with the same effect easily achievable by the use of much less expensive local products.

In practice some common parameters can be used to ensure a feasible design. Under normal commercial development circumstances, designers tend to use glass and other finishing materials (facebrick, tiling, Marmoran, or plaster and paint) to give the desired look (Fowler, 2009). The type of glazing impacts on certain specialist designs and will be discussed accordingly. It is when the percentage of glass exceeds 30% of the area of the façade when it becomes unfeasible design (Fowler, 2009).

The balance of the finishing on the façade is usually done with a combination of the above mentioned materials. Designers should also keep in mind the fixing method of the selected materials as some materials are mechanically fixed. The mechanical fixing of such materials will be very expensive which will drastically increase the square meter rate of such materials (Fowler, 2009).

Open minded designers that keep suitable alternatives materials and techniques in mind whilst doing the design, will deliver a just as immaculate appearance as their counterparts focusing only on the aesthetics and giving no attention to the cost of their design. Having this mindset may save a considerable amount of time in the design and budgeting stage of a project and by doing so according to the old truth “time is money” save on cost as well.

#### **2.3.3.8. ROOF CONSTRUCTION**

Roof construction is also one of the problematic structural components to design and cost. The reason for this is that this in many cases form part of the external façade or rather the external look and feel design. The architect will design on the look or materials to be used being a soft roof made up of structural steel members, insulation and metal plate sheeting or a hard concrete roof made up of reinforced concrete slab and water proofing or a tiled roof made up of usually timber roof trusses and roof tiles.

Each of these choices has a cost implication that need to be kept in mind whilst doing the design of the structure. The architect will decide on the type of roofing to be used and the structural engineer will design a structure to carry the desired type of roofing chosen by the architect (Fowler, 2009).

Three basic types of roofing is commonly used in commercial office developments (Fowler, 2009):

- Hard Roofs (Concrete roofs)
- Soft Roofs (Roofs constructed with trusses and sheeting)
- Tiled Roofs (constructed with roof trusses and either concrete or slate roof tiles)

Each of these influencing construction cost in their own way. Whether it impacts on the time needed to construct, or certain “hidden costs” not always kept in mind by the designer only looking to achieve a certain look or feel.

Hard roofs (concrete roofs) are by far the easiest roof to construct but may not be economical for the smaller developments. This is caused by a high cost per square meter rate that needs to be absorbed into the construction cost with no



contribution to the income generating potential of the building. Other costs to keep in mind with this roof construction is the fact that this roof consists of a slab of concrete that will need a screed, waterproofing, thermal insulation and finish where the other two types don't need any further finishing than that what the material itself delivers (Fowler, 2009).

The other two types of roofing are better suited to the smaller to mid range commercial developments with each of them with their own pros and cons. These roofing methods have lower costs per square meter and can more easily be absorbed into the feasibility without rendering a development unfeasible. Although soft roofs start off by having a lower cost this can easily change when designers don't give enough attention or design overly complicated flashing details.

#### **2.3.3.9. PARKING REQUIREMENTS AND FACILITIES**

Parking requirements and facilities is normally a costly part of the development. The structure to be erected will be inhabited by tenants, their staff and other people like visitors, maintenance staff, etc. Most or all of these people will need a parking to stop their car for the duration of the working day (Fowler, 2009).

In high density areas and small sites this may be a difficult and expensive problem to solve. In lower density areas or bigger sites this is much less of a challenge. In high density areas or on small sites it is very crowded and surface parking is not an option as result of a shortage of space. This problem is solved by the addition of basements to the structure. This is a very costly exercise and could easily change a profitable feasible project to not even being viable.

The use of basement parking once again influences the grid design of the building. As this area is such an expensive area to construct and contributes nothing to the usable area it is important to have this design as economical as possible with as little wasted space as possible. Once again the grid of 7m by 5m is the most economical as parking bays are normally 5m by 2.5m thus delivering two bays per grid block.

In lower density areas or on bigger sites this tends to be much less of a problem. In these cases parking can be added by simply adding open surface parking or

covered by way of a carport. This is much less expensive than basement structures (Fowler, 2009).

### 2.3.3.10. SITE CHARACTERISTICS

The site characteristics need to be kept in mind by the designing architect to avoid later implications as these usually cause changes and the implementation of changes are costly. Changes become more costly to implement the later in the construction process or programme they are incurred.

**Figure 6: Graphic illustration of the increase in cost to implement changes to the design throughout the construction process. (Kerzner, 2005)**

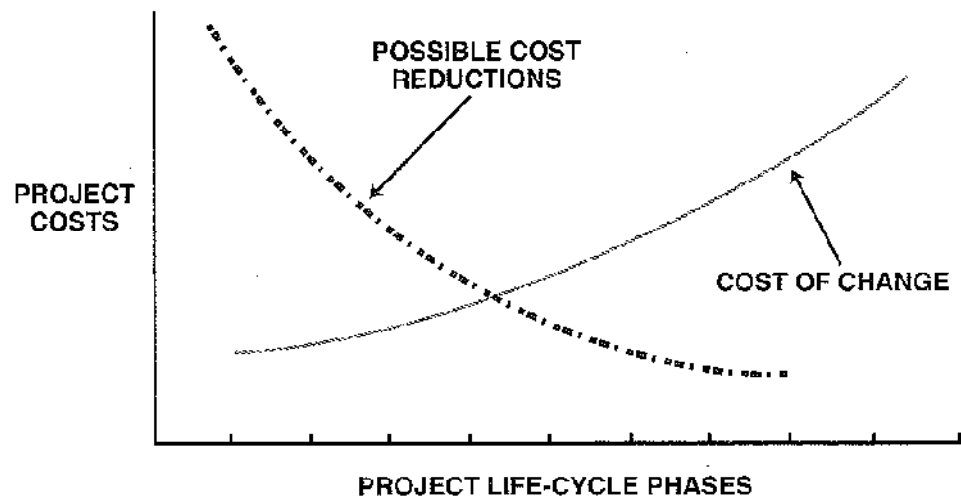

Designers should always take into account the unique site conditions and characteristics that may apply to the specific development. This is also the responsibility of the cost consultants to take these characteristics and conditions into account that cannot necessarily be seen in the design documentation.

Some of these characteristics to be considered during the budgeting for a development are (Pienaar, 2004):

- Geotechnical conditions (Nature of foundations)
- Sloping or level site
- Position of municipal sewer connections, resulting in excessive lengths of drains

- Access difficulties

## **2.4. SUMMARY**

In this chapter, an attempt was made to show the impact or influence the architectural design has on the feasibility of a construction project. For this to be possible it was necessary to show the role that the architect has to play in the design process. According to Finsen (2005) the architect is the main designer and although the architect does not design many of the specialist services or installation they are still responsible for the co-ordination of such services into the architectural design.

Later it is shown that many of the specialist and structural design is based and heavily influenced by the architectural design. The structural design, to only mention one, is totally dependent on the design of the architect the basic form, shape and grid layout of the building may have a detrimental impact on the economics of the structural design.

The architectural design principles investigated were:

- Optimal use of land rights and zoning
- Efficiency of design

The optimal use of land rights and zoning relates back to if the ability of designer to effectively use the land and rights to his disposal, to deliver a product that will satisfy the requirements of the developer. In most cases the developer has the same requirement or purpose as any other business venture to create wealth.

The efficiency of design on its part relates to the efficiency of the designed area. This is the ratio between the gross building/construction area to gross lettable (GBA) area (GLA) and the ratio between the usable area to gross lettable area (GLA). The GLA:GBA ratio gives a factor showing how much of the total designed space can be let to derive a income. The closer the factor to one the better the efficiency of the use of the space for income purposes. The Usable Area:GLA ratio gives another factor but this time the factor shows the amount of GLA that a tenant can actually use in the normal running of his business.

The General Design Principles investigated were:

- Size and shape of the building
- Height of the building
- Floor to ceiling height
- Grid design related to integration with the structural design
- Foyer and ablution design, finishes, accessories and fittings
- Fullness of the plan of the building
- Façade design
- Roof design
- Site characteristics

These principles are a few of many all influencing the construction cost of a building. The construction cost then influences the feasibility of the project by increasing the total capital outlay needed for the development.

To recap, when the size and shape of the building changes so does the cost of the construction and some shapes were shown to be more economical than others. The height of the building is simply, the higher the building the higher the construction cost and this is not just due to an increase in materials and labour needed but also due to other costs related to high-rise construction methods like crane hire, hoisting costs, etc. Floor to ceiling height showed to have a much larger impact than initially thought, as not only finishing quantities are influenced but also the quantities of dividing materials. The grid design will influence the economics of the structural design and will be discussed in detail later. Foyer and ablution design, accessories and fittings are influential not only on the construction cost as these are areas in which expensive finishes and fittings are cadenced but also influence the usable area:GLA ratio. The fullness of the plan of the building has the same impact that the floor to ceiling height but in this case only increasing the internal divisions and their finishing without influencing the cost of the external façade cost. Façade design plays an integral part in aesthetic design of the building which leads to a conflict between looks and cost. Glazing percentage, finishing materials and area play a huge role in the façade costing. Roof design also impacts the

structural design to be discussed later. Parking requirements and facilities regulated by statutory requirements this can be very costly especially when space is limited and basement parking is the only solution. Site characteristics also play a role and might have cost implications. Characteristics may influence structural design and in some cases cause difficulty with access or orientation of the building.

## **2.5. CONCLUSION**

To conclude the goal of the chapter was to show the dependency of price on the architectural design. The investigation above clearly shows that the architectural design cannot be altered without influencing construction cost. As shown the implementation cost of these changes increase exponentially when they are incurred later in the construction/development process.

It is for this reason that it may be a valid suggestion to have cost consultant input during the earliest stages of the design process (even during development the concept design). This should not be seen as a threat by design consultants neither should the cost consultants use this opportunity to totally dampen the creativity of design consultants. Rather if these two functions can be brought together in synergy the result may leave an impressive and feasible project which will be to the advantage to all parties concerned.

## **2.6. HYPOTHESIS TESTING**

Hypothesis as stated in chapter 1:

*“The architectural design will most definitely have an impact on the feasibility of a project as this design gives both the General Lettable Area (GLA) and General Building Area (GBA). The ratio between these two alone can be conducive or detrimental to any development.”*

This hypothesis has proved to be true. During the study conducted it was uncovered that the above mentioned ratio is not the only way the architectural design influences the feasibility of a construction project and that a much wider approach needs to be adopted to ensure a feasible design. This also pointed out the need that exists for getting cost consultants involved at a much earlier stage and using their experience and expertise to ensure an economically feasible design.

# CHAPTER 3: INFLUENCE OF STRUCTURAL DESIGN ON FEASIBILITY OF A CONSTRUCTION PROJECT

---

## 3.1. INTRODUCTION

In the following chapter the influence of the structural design on the feasibility will be investigated. This design is done by structural engineers who are also held liable for such designs. In many cases engineers are more focussed on the working of the design than the economic stresses that the design places on the feasibility of the development. Different engineers design from different points of view and it is essential for the cost consultants, in most cases the quantity surveyor, to understand where it is possible to suggest changes to make the design more feasible.

It is also very important for the engineer to understand that should a quantity surveyor or other cost consultants make such a suggestion it is not an attack on the design of the engineer but merely a suggested alternative that from past experience has shown to be a more economic solution to implement. Cost consultants will not be held responsible for the structural design as no design responsibility is placed on them nor are they trained for the design of such structures. These suggestions should first be tested before implemented into the structural design of the structural engineer.

## 3.2. ROLE OF THE STRUCTURAL ENGINEER

The structural, mechanical and electrical design of modern buildings have become so involved that it has extended beyond the expertises of the architect who usually is the principal design agent (Finsen, 2005). Building regulations today also ask for the design of so-called specialist services to be undertaken by a competent and registered engineer (Finsen, 2005). The design processes is initiated by the architect by doing his concept design according to the brief of the employer/client/owner. This concept design is then further developed into a preliminary

design. This entails the concept design being assessed by the structural engineer to design a safe structure.

Different construction methods can be used in ensuring a safe structure. These methods are concrete slab, beam and column construction, steel column and beam construction and timber construction with the first mentioned being mostly used in South-Africa. This is primarily because of the high cost of steel in South-Africa while the timber method is mostly used in areas with less harsh climates. The South-African climate causes extensive maintenance cost due to harsh sun and rain conditions.

The structural engineer now takes the concept design of the architects and develops a system of columns and beams to support the structure. This column and beam design carries any number of concrete slabs, these elements are all formed by placing steel reinforcement into concrete formwork and then pouring the concrete mix into these forms. The concrete consists of a mixture of sand, cement, aggregate (rock) and water. The cement reacts with the water to bind all of the above mentioned materials together this now bound together to form the material commonly known as concrete. The main characteristic of this material is its high compressive strength while on the other hand the material is weak in tension. The solution for this problem is placing steel reinforcing rods in the concrete components where these components may find to be in tension. This is due to steel reinforcement rods having a high strength in tension.

**Figure 7: Graphic illustration of the placement of steel reinforcement in concrete components. (Source:www.globalsecurity.org)**

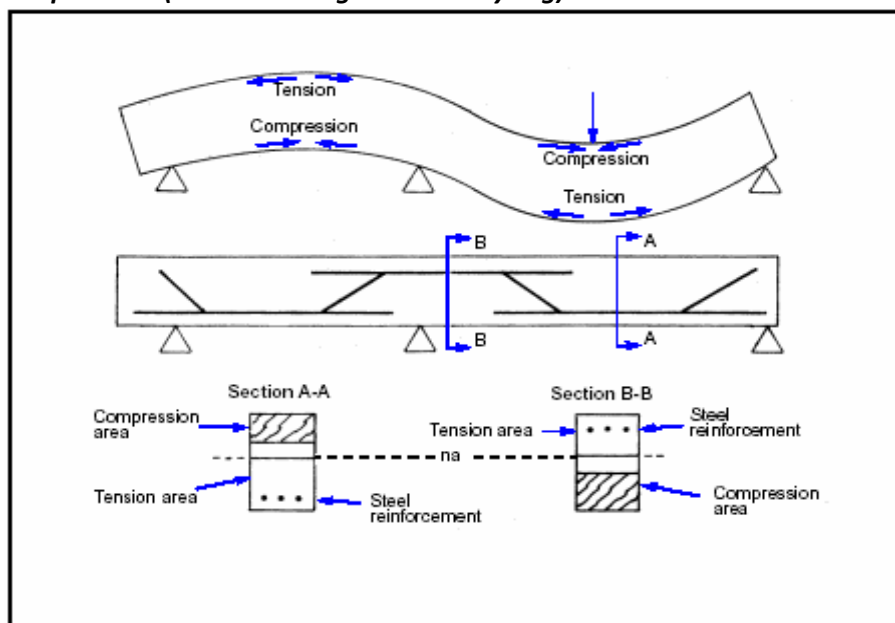

The principle shown above is used in the design of all concrete components with steel reinforcement being placed in the sections of the components that are found to be in tension.

### **3.3. DESIGN COMPONENTS**

The main objective of the structural engineer is to develop a design that provides a safe space or environment in which the inhabitants of the building can function. The building should be structurally sound and able to handle the wind loads and other loads imposed upon it either by the environment its inhabitants or any external sources.

As previously mentioned the most commonly used method of construction in South-Africa is the concrete structure with brick infill. The concrete is used to form load bearing components, these components can be found in components foundations, superstructure and roof.

#### **3.3.1. FOUNDATIONS**

Foundations are an essential part of the structural design and the function of the foundations are to transmit the concentrated structural loads to the generally much softer material found in the earth's crust (Seward, 2003).

The design of the foundations is primarily based on a report prepared on the soil conditions on the site. This soil report is called a geotechnical report and is prepared by the geotechnical engineer. This report is prepared after a geotechnical investigation has been done. This investigation is done by drilling holes on site with a core drill and the core material is then taken to a laboratory for assessment. The report gives a clear indication of the soil conditions found on site and what foundation type is to be considered.

Three basic types of foundations are used in construction, strip footings with pad footings for columns, piling and raft or mat foundations (Nunnally, 2004).

##### **3.3.1.1. STRIP FOOTINGS WITH CONCRETE PAD FOOTINGS FOR COLUMNS**

This is by far the most commonly used foundation type (Nunnally, 2004). It consists of a rectangular linear excavation with steel reinforcement placed at the bottom for the trench before concrete is cast in the excavations. These strip footings ensure the transfer of the load of the building over a large enough area as not to exceed the soil's allowable bearing strength (Nunnally, 2004).



**Figure 8** *Figure 8: Illustration of a strip footing/foundation under a wall. (Source: [www.architecturalguidance.blogspot.com](http://www.architecturalguidance.blogspot.com))*

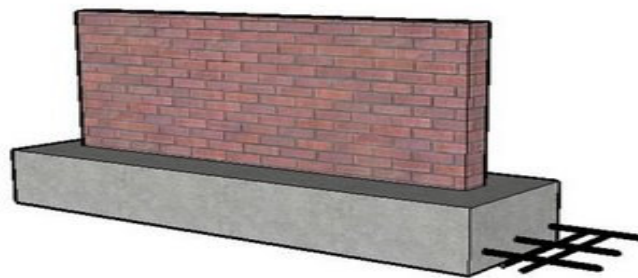

#### **3.3.1.2. PILING**

In the words of Nunnally (2004) *“piling is nothing more than a column driven into the soil to support a structure by transferring building loads to a deeper and stronger layer of soil or rock”*. Two functional types of piles exist, end-bearing piles and friction piles (Nunnally, 2004). The end-bearing piles distribute the load to the end of the pile that transfers the load to the much deeper but better founding material. The second type of pile transfers the load through friction to the neighbouring encasing soil.

Figure 9: Pile foundations. (Source: www.acehomeinspec.com)

### Pile foundations

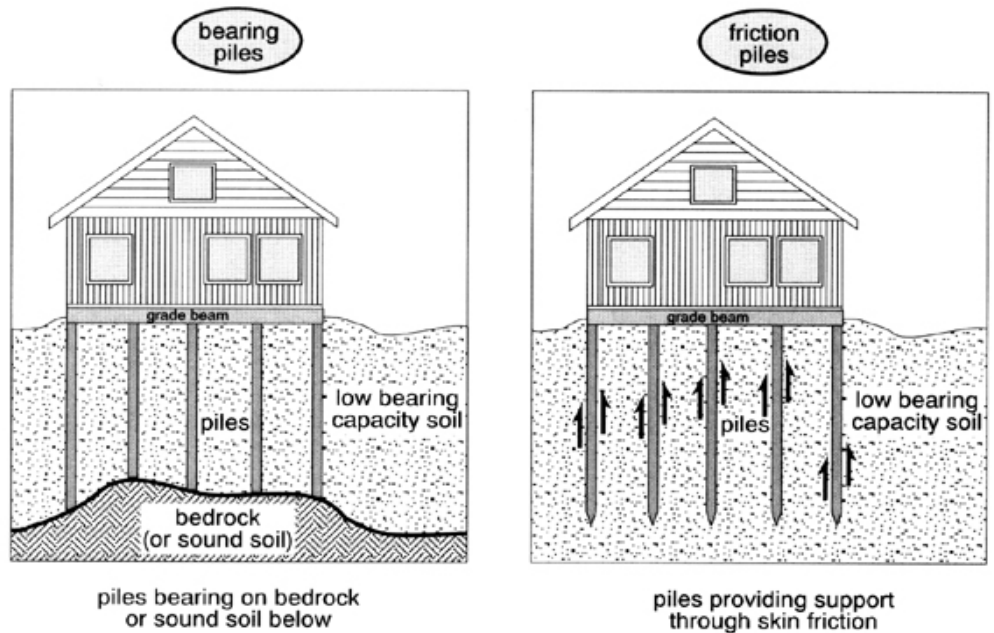

#### 3.3.1.3. RAFT OR MAT FOUNDATIONS

Raft or mat foundations are used in areas where soil is soft and prone to movement due to high clay content (Coetzee & Hauptfleisch, 1999). This movement is caused by the characteristic of clay soil, when clay soil comes into contact with moisture it swells considerably and thus can cause extensive uneven movement or settlement of the structure.

In situations like these raft foundations need to be used to counter or allow for these extensive movement and safeguard the structure against becoming structurally unstable. Raft foundations takes the form of a reinforced concrete slab laid flat on the ground, usually one can find a network of ribs and ground beams on the underside of the raft. The raft will then support the entire building. This will have the effect that when the soil moves the building will move uniform or evenly with the soil.

**Figure 10:Raft or Mat Foundations. (Source: <http://osp.mans.edu.eg/deepfoundation/ch1.htm>)**

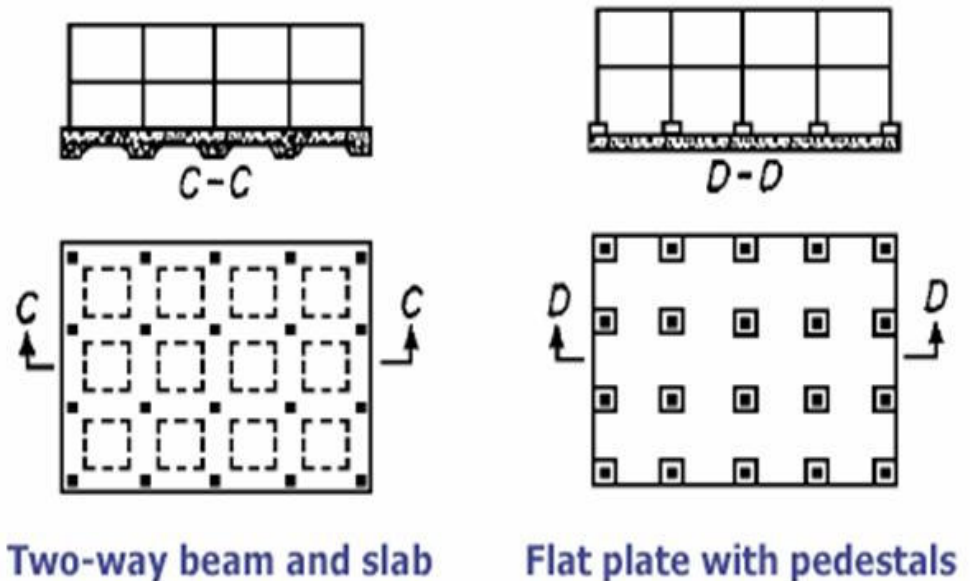

### 3.3.2. SUPERSTRUCTURE

The superstructure of a building is the portion extending from the foundations to the roof structure. This is the area in which the occupants use the building for its intended use whether it is for residential or commercial use.

The structural design of the superstructure is intended to relay any loads or forces imposed on it safely and efficiently down to the foundation of the structure. The foundations in turn will then distribute the loads evenly to the soil or earth below the building not to exceed the bearing capacity of such soil or earth.

The superstructure is developed by using a design of columns, structural walls and bracing, beams and slabs.

#### 3.3.2.1. COLUMNS

Columns are vertical elements that keep the structure up and give it height. The column carries the load vertically down the structure to the foundations to be distributed to the soil or earth below. Columns are vertically upright and connect from foundations to slab from slab to slab and from slab to roof structure.

**Figure 11: Concrete column and formwork. (Source: [www.builderbill-diy-help.com](http://www.builderbill-diy-help.com))**



The process in constructing a column is shown above first the formwork for the column will be put up, where after the reinforcement bars will be inserted into the formwork. The concrete is then poured into the formwork and left to cure. After curing the formwork is removed leaving behind a reinforced concrete column like the column that can be seen in the background of figure 10.

### **3.3.2.2. STRUCTURAL WALLS AND BRACING**

In higher multi floor buildings the vertical forces caused by winds and external factors must be kept in mind as the higher the building gets the bigger these forces become (Steward, 2003). In many cases extra precautions or bracing is needed to overcome this problem.

This extra bracing can take the shape of walls parallel to the wind (force) direction, bracing of portal frame buildings, taller buildings supported by shear walls, adding diagonal bracing to tall buildings, implementing a central concrete core , like a concrete lift shaft or using shapes with inherent lateral strength like arches in the design of the building(Steward, 2003).

**Figure 12: Sketch illustrations of the implementation of structural walls and bracing.**  
 (Source: Steward, 2003)

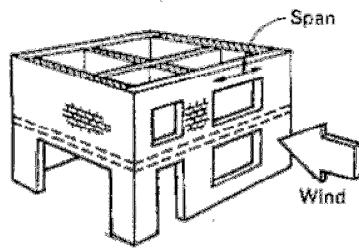

Walls parallel to the wind direction provide stability

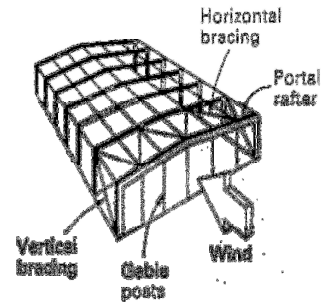

Bracing of a portal frame building

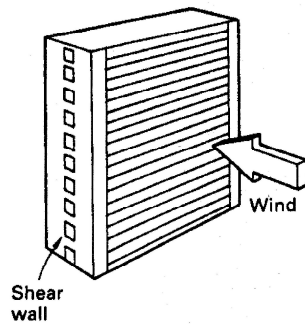

A tall building supported by shear walls

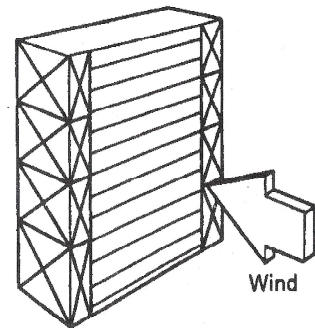

A tall building with diagonal bracing

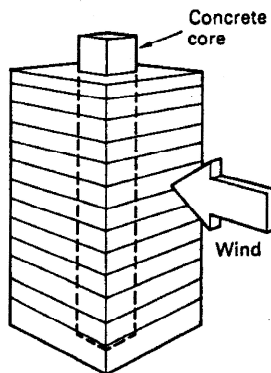

A tall building with a central core

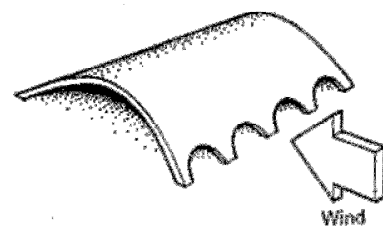

Arched structures have inherent lateral strength

### 3.3.2.3. BEAMS

Beams are horizontal structural elements that are used in the structural design and its primary use is for spans from column to column and above openings. The

reason for this is to make certain other structural components more economical. Like in the case of a concrete slab, by designing beams underneath the slab the thickness of the slab can be drastically reduced and thus saving on the concrete needed to provide a safe floor slab.

It does make sense to reduce the concrete needed for the slab but one should keep in mind that this does not come without cost. The introduction of beams into designs does save on the concrete needed for the slab but it adds to the concrete needed for beams and another extra cost sometimes forgotten is the cost for the formwork to the sides and soffits of beams. In many cases the introduction of the beams may be even less economical than the use of the original thicker slabs (Fowler, 2009).

Beams are formed by building out the formwork at the bottom edge of a slab to receive reinforcement and then concrete. This has the effect of deepening the “slab” in certain areas to enlarge the area of concrete in compression as we know concrete’s strength is much higher in compression than in tension.

Steel beams can also be used instead of the concrete beams but as earlier mentioned steel construction is much less economical in South-Africa than in other parts of the world because of the high steel prices (Fowler, 2009).

**Figure 13: Sketch illustration of reinforced concrete beam. (Source: Steward, 2003)**

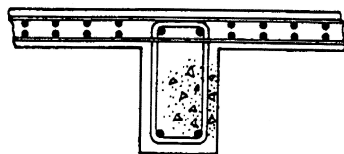

**Figure 14: Sketch illustration of concrete slab spanning between steel I beams. (Source: Steward, 2003)**

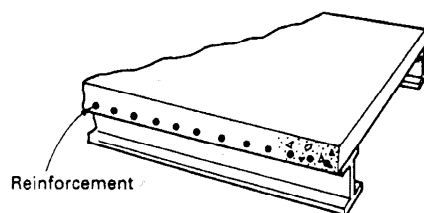

#### **3.3.2.4. SLABS**

Reinforced concrete slabs are the final concrete component to the superstructure. This is used to form the floors of the building. These follow on one another to give the functional space to be used by the occupants of the building.

Reinforced concrete slabs are formed in much the same way as the other reinforced concrete components. First formwork to soffits and edges of slabs are placed including the formwork for beams if so required. After the formwork is completed a grid of reinforcement steel rods is placed on spacers to ensure sufficient concrete coverage. Concrete is then cast into the prepared formwork with the reinforcement left to cure.

**Figure 15: Photo of slab formwork, reinforcement bars and electrical conduits ready for casting of concrete. (Source: concrete-forms.blogspot.com)**



#### **3.3.3. ROOF STRUCTURE**

The roof structure is the last component to the structural design. There are many types of roofing used in commercial developments. Usually this is dependent on the design of the architect and the size of the development.

Basically, there are three structures for the design of a roof over a structure in commercial office block developments, steel roof trusses, timber roof trusses and flat or concrete roofs.

##### **3.3.3.1. STEEL TRUSSES & TIMBER TRUSSES**

In the design of the building the architect will decide on a certain aesthetic appearance which usually will include the type of roofing material and type of roof that is to be used. Roof trusses can be manufactured out of wood or steel and is an

economical way of carrying relatively low mass roof covering over relatively long spans (Steward, 2003).

Roof trusses whether manufactured out of timber or steel are made up out of a number of members. With some members in tension called ties and other members in compression called struts. These struts and ties are connected in such a manner to form a number of triangle shapes to make up a roof truss (Steward, 2003). The specified roof covering whether being concrete roof tiles, slate roof tiles or metal roof sheeting is then placed and in some cases fixed to the roof trusses. These type of roof structures tend to be the most economical and thus more feasible for smaller commercial developments (Fowler, 2009).

Steel roof trusses are usually designed by the structural engineer, whilst timber roof trusses are usually designed by a specialist roof truss contractor, after which the structural engineer checks the calculations done by the specialist contractor.

**Figure 16: Typical timber roof truss. (Source: [www.renovation-headquarters.com](http://www.renovation-headquarters.com))**

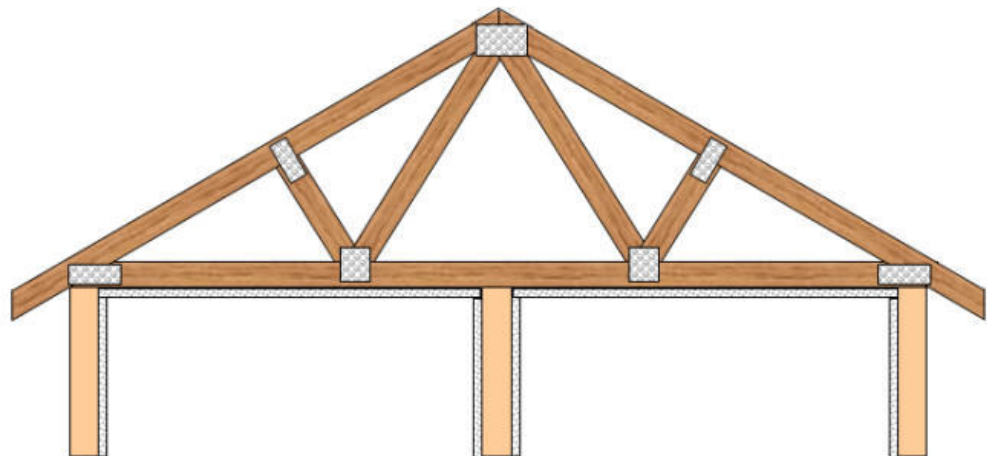

### **3.3.3.2. CONCRETE ROOF SLABS**

Concrete roof slabs are by far the most expensive of the roof structures. Only bigger commercial developments warrant the use of the concrete roof as the cost per square meter of GLA in such bigger developments are lower than that of the smaller developments.

Concrete roof slabs are designed in the same manner as any other slab with some extra requirements. These slabs need extra waterproofing as concrete is a porous material and standing water will eventually seep through. This is done by first



adding a screed to falls to help water runoff and direct such run-off to full-bore outlets in the concrete slab. Secondly, a waterproof bituminous layer is torched on and finished off with protective paint, paving or stone layer. Heat insulation is also required for these roofs as they tend to heat up during summer days passing the heat on to the interior of the building, during winter times the concrete may also cool down and have an unwanted cooling effect on the interior conditions.

#### **3.3.4. SUNDRY STEEL ITEMS**

In relevant cases the structural engineer will also design or signoff on specialist subcontractors design of sundry steel items. These may be steel staircases or any other item that may influence the structural integrity of the building.

### **3.4. QUANTITY SURVEYOR'S INPUTS IN STUCTURAL DESIGN**

As in the previous discussion the contributions of the quantity surveyor can also be discussed in the three main design components.

Firstly the foundations, an ironic fact is that the first part built is the last part to be designed (Fowler, 2009). This may sound confusing at first but when one thinks about it makes perfect sense, the foundations can only be designed once the load it must carry is known. For this reason structural engineers do the design upside down, the starting point is the roof followed by the superstructure and finally the foundations (Fowler, 2009).

Let us start with the roof structure, this is the simplest of the structures to design as it should fit the architects design of either mono-pitched, saddle or flat concrete roofs. Many variations of the above mentioned exist to give the desired look or effect.

The ranking in economical order, starting from most to least economical, is timber roof trusses with concrete roof tiles, secondly steel trusses with metal roof sheeting and least economical for smaller developments is flat concrete roofs. The application of flat concrete roofs is mostly for the bigger or rather multi-storey office block (Fowler, 2009).

The super structure as discussed earlier is made up of reinforced concrete columns beams and slabs. The economics of this design is almost entirely founded on the column spacing used. As the spacing becomes greater the bigger the spans from column to column and thus the bending moments that need to be alleviated. Economical column spacing is a grid of 7m by 5m which delivers the most economical 255mm reinforced concrete slab with no need for reinforced concrete beams (Fowler, 2009). In a perfect world this might be possible but as the

space requirements don't always allow for this layout the economics need to be discussed a bit further.

As previously stated some elements are more economical than others and some misperceptions exist in terms of economics of design. Previously was mentioned that the use of beams are a more economical option than thicker slabs so designers may opt for adding in beams instead of thickening the slabs. This is not always the case and as a matter of fact when the costing exercise is done it has often proved to be completely untrue (Fowler, 2009). Beams are a time consuming element to set out for contractors and causes slower placement of formwork for slabs and for this reason contractors tend to price formwork to sides and soffits of beams at a much higher rate than formwork to soffits of slabs (Fowler, 2009). The result is often that it may be more economical to thicken the slabs as long as the reinforcement is not altered. At last the point must be made that the cleaner the design (only columns and slabs and no beams) the more economical (Fowler, 2009).

Once the structure is complete the load that the foundations should be able to carry is known. The geotechnical report will show underlying ground conditions and thus influence the choice of type of foundation to be used. Economically speaking the best foundation solution is using normal strip footings in good founding material (Fowler, 2009). When the surface material has a poor bearing capacity the use of piling becomes more feasible (Fowler, 2009).

The quantity surveyor sees the design from a different perspective than the structural engineer and may just suggest a more economical solution to an engineering problem than the normal design. Although the suggestions might not always be viable it is worth a quick calculation.

### **3.5.SUMMARY**

Because of the complexity of structural design and a change in National Building Regulations the structural design of a building is undertaken by a registered structural engineer (Finsen, 2005). Structural engineers may be so involved in ensuring a safe structure that the first design is not always the most economical. This is caused by certain misperceptions like the perception that adding more beams to reduce slab thickness are always more economical (Fowler, 2009).

Cost consultants may out of previous experience be able to suggest more economical solutions. These solutions are to be suggested by the cost consultant and tested by the structural engineer for implementation in the structural design.

The structure consists of four main elements, foundations, superstructure, roof structure and sundry metal items. Under the foundations element there is basically a choice between three main types of foundations namely, strip footings with pad footings for columns, pile foundations and raft or mat foundations.

Under the element superstructure the structural engineer uses, columns, structural walls and bracing, beams and slabs to deliver the occupy able space. And in the roof structure the use of trusses and roof coverings as opposed to more expensive flat concrete roof needs to be explored. Sundry steel items like steel staircases are not always present but, when they are need to be signed off by the responsible structural engineer.

### **3.6. CONCLUSION**

To conclude the quantity surveyor may not have the design responsibility of the engineer and cannot take any professional liabilities for suggestions made but an inexperienced designer may be able learn about economical design from an experienced quantity surveyor.

### **3.7. HYPOTHESIS TESTING**

Hypothesis as stated in chapter 1:

*“As the architectural design impacts on the GLA:GBA ratio, the structural design may impact greatly on the building cost of the proposed project. The method of construction and application of the chosen method will have an effect. For instance if concrete frame construction is chosen, then different permutation exist for the use of slabs with beams as to the use of flat slabs without beams.”*

This hypothesis has proven to be true during the discussion of the structural design by the structural engineer it was mentioned that the engineer is mostly bothered by safety and delivering a safe structure for the occupants to function in. This is not wrong as this is the primary goal of the engineer, when the focus is placed on safety like in many other cases the cost of construction may increase because of an uneconomical design. This is why the structural engineer and cost consultant need to work together to ensure that the most economical safe structure is the result of the structural engineers efforts.

# CHAPTER 4: INFLUENCE OF SPECIALIST SERVICES DESIGN ON FEASIBILITY OF A CONSTRUCTION PROJECT

---

## 4.1. INTRODUCTION

In the following chapter the influence of the specialist designs on the feasibility will be investigated. This design is done by a variety of specialist engineers that specialise in the design and development of their respective trades. The purpose of this discussion is not to investigate in detail the workings of HVAC systems or the load calculation by the electrical engineer, but rather to show that a bit of open minded design may help the feasibility of any construction project. Currently, economical design of such specialist services is essential for deriving the return required by developers. In current market (2009) conditions it is critical to show a return as favourable as possible for financial institutions to even consider financing a development project.

## 4.2. ROLE OF THE SPECIALIST ENGINEERS

Specialist engineers are appointed as agents to the employer/developer. These engineers form part of the professional team and carry risk and responsibility for the designs that they deliver on the project.

### 4.2.1. ELECTRICAL ENGINEER

The role of the electrical engineer includes calculation of load requirements design of the reticulation and distribution networks. The electrical engineer is also responsible for:

- Preparation of tender documentation for the electrical subcontracts.

- The monitoring of the progress of the contract and preparation of interim payment valuations.
- Cost management and cost reporting also forms part of the services delivered to the employer (Fowler, 2009).

#### **4.2.2. MECHANICAL ENGINEER**

The role of the mechanical engineer includes calculation of requirements for the effective Heating Ventilation and Air-conditioning (HVAC) system and:

- The effective application of vertical lifting of people and equipment.
- The vertical lifting is usually done by means of lifts and escalators while the climate control may vary from complex HVAC systems to fresh air fans.
- Preparation of mechanical subcontract documentation.
- Monitoring of the contract progress and the preparation of interim payment valuations.
- Responsible for cost management and reporting as part of the services delivered to the employer (Fowler, 2009).

#### **4.3. DESIGN COMPONENTS OF SPECIALIST ENGINEERS**

The specialist services in a normal commercial construction project include electrical distribution and reticulation networks, voice, access control, CCTV, public address and evacuation, smoke detection, HVAC systems, lifts, escalators, conveyer belt systems, to only mention a few (Fowler, 2009).

During the design stages the specialist designers are required to produce a specification document and cost estimation for incorporation into the financial feasibility usually prepared by the quantity surveyor.

**The following is an example of such a specification document prepared by the electrical engineer (from working documents for Rosebank office block, 2008):**

## **ELECTRICAL INSTALLATION**

### **1.0 INTRODUCTION**

This document confirms the base line allowances of the following services in the new development in Rosebank.

- Electrical.
- Back-up power supply systems.
- Bulk Power Supply upgrade to the site.
- Fire detection and emergency evacuation.

### **2.0 SERVICES**

The following are considered to be a condensed summary of the electrical and electronic services which will be elaborated on in the report:

- Electrical installation with associated density of service outlets.
- Interior and exterior lighting designs.
- Generator installation.

### **3.0 ASSUMPTIONS**

All assumptions will be discussed under the respective headings.

### **4.0 TRANSFORMERS**

Based on a power density of 100VA/sqm, a 315kVA oil immersed miniature substation will be provided for the development. This will be located on the site boundary, complete with metering and necessary protection.

### **5.0 PRIMARY RETICULATION**

The primary reticulation to the various floors will be designed to cover the power reticulation as per Item 7.

Sub-metering for multi-tenant has not been allowed for on this site.

### **6.0 DISTRIBUTION BOARDS**

Each floor will be equipped with a main floor distribution cabinet and one distribution board also only making allowance for one category of power being emergency power. The air-conditioning distribution boards will only have the normal category of power.

## **7.0 DESCRIPTION OF POWER RETICULATION**

There shall be 1 x switched socket outlet per 12 m<sup>2</sup>. The power will be distributed from the main low voltage distribution board to sub-distribution boards on the floors, via structured riser ducts, that are dedicated for power distribution. The main method of the power distribution to the office area, will be done with standard 3 compartment, 2 cover power skirting.

Domestic power will be installed on columns and at intermittent frequencies for cleaning operations.

## **8.0 DENSITIES**

### **8.1 *Power and data***

We confirm the power density will be 1 switch socket outlet per 12 m<sup>2</sup>

### **8.2 *Data and voice cabling systems***

It should be recorded no allowances were made for structured data and voice cabling installations being normally excluded from the base building provisions.

## **9.0 CAPACITY**

The above densities will again be verified against the space planning concept.

Full saturation to comply with acceptable norms shall be provided. Acceptable norms shall be at least a 20% spare capacity once all requirements have been catered for.

## **10.0 CABLING**

We record again the provision for voice and data cabling has been excluded from the base building budget.

## **11.0 VOICE**

No provision for Telkom applications or any cabling has been allowed for in the base building cost.

## **12.0 ACCESS CONTROL**

No provision has been made for an ACS as part of the base building budget.

## **13.0 GENERATORS**

No provision has been made for a generator.

#### **14.0 DISTRIBUTION BOARDS**

Each floor will be supplied with a main distribution cabinet and one distribution board and shall:

- cater for the categories of power referenced earlier in the scope statement.
- shall have at least 20% spare capacity in space and future load growth.  
shall have full instrumentation w.r.t. ammeters etc.

#### **15.0 CABLE LADDERS**

All cable ladders shall be designed to have 50% spare capacity.

The cable ladders shall be configured to accept the data and voice termination plates.

#### **16.0 MAINTENANCE**

All installations shall be covered by 12 month maintenance.

#### **17.0 CCTV**

No provision has been made for a CCTV system as part of the base building budget.

#### **18.0 PUBLIC ADDRESS AND EVACUATION**

A full emergency evacuation and public address system will be provided, in compliance with local by-laws.

#### **19.0 SMOKE DETECTION**

All areas shall be provided with a fully addressable smoke detection installation.

The smoke detection system will be linked to the lift installation, Evacuation System and the smoke extract system. No ceiling smoke detection have been included but it may deem necessary to omit baffles in ceiling and install a smoke detection system if so required by the Fire Department.

**The following is an example of such a specification document prepared by the mechanical engineer (from working documents for Rosebank office block, 2008):**

#### **MECHANICAL INSTALLATION**

Air-conditioning will consist of reverse cycle (heat pump) in-ceiling (hideaway) split units ducted to ceiling diffusers.

The allowance would be 1 of 14kW unit per 100m<sup>2</sup> of occupied air-conditioned space.

Each unit will have a control thermostat.



There is no provision for individual control of cellular spaces within the 100m<sup>2</sup> served by a unit.

Fresh air provision will be fresh air intakes, filters and fresh air fans ducted to each in-ceiling unit.

Mechanical toilet and tea kitchen ventilation will be provided to SANS 10400

Basement ventilation to SANS 10400 subterranean levels only. Not rated for fire duty.

Above grade parking will be naturally ventilated.

Toilet and tea kitchen extraction.

Basement ventilation (subterranean levels only)

**Exclusions:**

Outside louvers

**4.4. QUANTITY SURVEYOR'S INPUTS IN STRUCTURAL DESIGN**

As previously stated, the opportunity for inputs by a quantity surveyor diminishes as the design becomes more finalised. The cost of implementing changes into the design also becomes more costly as it may cause duplication of work. For this reason the quantity surveyor must be part of the initial design process in his capacity as cost consultant.

In short the process to be followed to allow effective inputs by the quantity surveyor can be seen as the following:

- System specification to be done by the consulting mechanical engineer.
- Estimated price to be compiled by the consulting engineer.
- Estimated price to be delivered to the quantity surveyor for incorporation into the complete financial feasibility.
- Quantity surveyor to deliver comments on the impact of this cost on the financial feasibility.
- If impact is detrimental the quantity surveyor and client is to prepare a viability study comparing possible alternative options to improve project feasibility.

- Consulting engineer to test alternatives suggested by quantity surveyor and client to establish if the alternatives are practical.
- If practical the revised cost estimate is once again incorporated into the project feasibility to assess the impact thereof.
- The value engineering process will repeat itself until a practical solution to the problem is found.

The quantity surveyor cannot take responsibility for the design of such specialist services as he has no formal training in the design of such specialist services. The quantity surveyor will rely on the experience gained from previous similar projects undertaken to draw similarities and suggest alternatives that in some cases may be more economical thus impacting the feasibility in a positive manner.

In many cases the proposed tenant for the developed space may have specific requirements pertaining to such specialist services as air-conditioning or electrical supply. The application of the proposed development also impacts on these requirements. In the case of the tenant having special or specific requirements the employer may decide what his contribution towards these extra costs will be if any. The balance of the cost will be put to the tenant in a document called a tenant account. The tenant account is a summary of costs that the tenant himself will settle and will not be settled by the employer. This tenant account is to be prepared and updated by the quantity surveyor to assure that both the tenant and the employer are certain of the stance of their respective accounts.

#### **4.5. SUMMARY**

In this chapter it is seen that the quantity surveyor has very limited time to impact the design of the specialist consultants. The quantity surveyor cannot design such systems and can only comment on cost or propose alternatives out of past experience and knowledge acquired on previous projects.

Specialist consultants calculate requirements for the application of their designs and prepare cost estimates for the implementation of their designs on the project. Their responsibilities include preparation of a baseline specification (like the examples above), preparation of tender documentation and contract administration of the specialist subcontracts.

The main contribution of the quantity surveyor is to assist in incorporation of an economical design into the project feasibility and thereafter assisting in preparation of contract documentation, cost control and budget management.

#### **4.6. CONCLUSION**

To conclude the area of specialist design is one of the most difficult to impact as a quantity surveyor. A quantity surveyor has limited knowledge on the respective fields. In many cases it is only the more experienced quantity surveyor that may have a significant impact on such designs and in so doing better the feasibility of the proposed development project.

#### **4.7. HYPOTHESIS TESTING**

Hypothesis as stated in chapter 1:

“With the provisional sums of a project contributing more than half of the contract value the economic design of such components will influence greatly the outcome of any project. The impact is often forgotten or underestimated as the detail design is mostly done during the run of the project. If sufficient care is not given during budgeting design and tender of these items the budget overruns may cause a reduced return and influence the final success of the project.”

Through the above discussion the hypothesis has proved to be true, uneconomical design by specialist consultants can greatly influence the feasibility of a proposed development and in many cases cause a project to seem unfeasible. The main problem is that it is really only the experienced and knowledgeable quantity surveyor that may be able to propose alternatives to the design of the designer to increase the feasibility of the development. This knowledge is only acquired when quantity surveyors together with employers and specialist designers team up and workshop such problems to find the most practical and economically viable solution.

# CHAPTER 5: CLIENT AND QUANTITY SURVEYOR RELATIONSHIP WITH QUANTITY SURVEYOR AS DESIGN CONSULTANT

---

## 5.1. INTRODUCTION

In the previous chapters an attempt was made to show the influence the quantity surveyor may or can have when given the appropriate opportunity. This would mean that the role of the quantity surveyor may change considerably. With this in mind one needs to understand that this change will cause a change in the relationship of the quantity surveyor with other consultants as well as the relationship with the client.

In this chapter an attempt will be made to investigate the changes needed to give the quantity surveyor the opportunity to have the most effective influence on the design and how the relationship with the client will change. Once again the fact that the quantity surveyor has no design responsibility must be underlined. This would mean that the quantity surveyor is only able to comment on the design of the design consultants (Architect and Engineers). The comments will mostly be on the practical and financial implications of such designs.

This is aimed at delivering the most efficient design and optimising the return on investment that the client or investors may expect. With current market and financial situation (2009) it is also of utmost importance to show the optimal return as this is one of the criteria used by financial institutions in evaluating whether it will supply finance for the project.

## 5.2. HISTORIC ROLE OF THE QUANTITY SURVEYOR

Historically the quantity surveying profession could have been seen as being a boring, technical, number crunching profession that is more reactive to historical data than anything else. This can be accredited to the development of technology, before the development of the

computer all work was done by hand and thus at a much slower pace as work today. The historical role of the Quantity Surveyor included functions like (Moss, 2004):

- Measurement, Quantification and Preparation of Bills of Quantities
- Preparation of Contract Documents
- Cost Planning
- Cost Control
- Procurement Advice
- Contract Administration

All of the above mentioned functions today still form part of the role of the quantity surveyor. Today most of these functions are performed at a fraction of the time used previously. This is mainly attributed to the implementation of computer technology and the fact that the vast majority of contracts today are fast track contracts.

### **5.3. CURRENT AND FUTURE ROLES OF THE QUANTITY SURVEYOR**

The change in technology and fact that contracts are done on the basis of fast tracking brought with it new difficulties and opportunities for the quantity surveying profession. This meant that the quantity surveyor needed to adapt to accommodate the new manner of preparation of procurement documentation and then the management of these procurement documents.

The implication of the change is that work that previously was performed over a period of three months is now being done in about two weeks. This in itself shows that the documentation cannot be of the same accuracy type or state of finality. This is the reason for provisional bills of quantities. The implication is that bills of quantities are prepared on uncompleted design information to obtain rates from tendering contractors. After completion of the project the works are remeasured and priced at the bill rates to derive a final account or final cost. This process saves huge amounts of time in the procurement of a contractor but increases the amount of administration considerably. This means that the role of the quantity surveyor now needed to include the following new functions of attributes (Moss, 2004):

- Auditing
- Facilitating

- Leading
- Managing of the development process

These new functions or attributes are essential for the successful completion of a construction process. This modern manner of procurement needs quantity surveyors to be involved, proactive and dynamic to manage, guide and ensure a favourable outcome for the client.

This change in the industry brought that a quantity surveyor moved from being seen as (Moss, 2004):

- A number crunchers to a facilitator
- An estimator to a cost manager
- A brick counter to a value manager
- Over technical to a peoples person
- An old hat to an innovative person or profession
- Boring to being dynamic

These changes were forced as times and methods of working changed this in turn changed the requirements for being a successful quantity surveyor.

#### **5.4. CALLEGES TO THE CHANGE IN ROLES**

As in any other profession there are some challenges posed by and to the change in role. Some of these challenges posed are (Moss, 2004):

- Image
- Acceptance
- Recognition (“Professional Service”)
- Scope
- Competition
- Rivalry
- Professional “Snobbery”

Firstly, an image that has formed over hundreds of years is not easily changed. Quantity surveyors have a perceived role that of being primarily responsible for the preparation of estimates and procurement documentation, this might have been the case historically but in current times the quantity surveyor is much more involved in the management of the construction process.

Acceptance of this change is also a challenge. The quantity surveyor is in modern times much more involved in the design stages of the construction process. Other design consultants may be offended by a non design consultant commenting on their designs. The purpose of such comments is to deliver the most cost effective design to the client.

For the purposes of this discussion recognition, scope, competition, rivalry and professional “snobbery” play less of a role. These may be challenges posed but are more relevant to challenges between consultants rather than challenges between the quantity surveyor and the client.

#### 5.5. THE EMPLOYER’S (CLIENT’S) PERSPECTIVE

To complete this study the opinion of employers or clients were needed. To acquire these opinions questionnaires were prepared and sent to two commercial developers. These questionnaires were not meant as a sample (in this case two employers chosen) of the entire population (the total number of employer in construction) and therefore holds no statistical value. These were merely meant to show the difference or similarities in opinion of two employers receiving the same service from the same company.

The following is an example of the above mentioned questionnaire:

#### Questionnaire:

**Thank you for your contribution towards the study!** The purpose of this study is to determine the perception of professional quantity surveyors and to identify services and skills available to clients/employers and the utilization thereof. Please keep this in mind when answering the question. Any extra comment will be appreciated.

1. In your professional opinion please rank the importance of consultants during the early design stage of an average size development project. (Rank by numbering from 1 to 7 with 1 most important.)

Project Manager	
Electrical Engineer	
Quantity Surveyor	
Landscape Architect	

Architect	
Mechanical Engineer	
Interior Designer	

2. Please compile a list of services you expect from a professional quantity surveyor (PRQS).

3. In your opinion, do professional quantity surveyors (PRQS) possess services or skills that may be of help and contribute towards the feasibility or viability of a development project (other than pure number crunching)?

4. Are you of opinion that assessment methods exist for the testing of efficient and optimal design?

5. Based on past experience, would you say that experienced professional quantity surveyors (PRQS's) have sufficient knowledge and skill to oversee a project as the principal agent and or project manager?

Results obtained from the questionnaire conflict with the earlier assumption where it was thought that the difference in opinion would lie in the delivery of service during early design phases. Both the developers were adamant that the quantity surveyor plays a critical role in the design phase even as early as the concept design. This was shown in both cases where the rating of the professional resulted in a 1 rating for the architect and quantity surveyor.



It was surprising to see this result and then later see that both developers were not familiar with the testing criteria for optimal and effective design. This might mean that the quantity surveying profession is found lacking in promoting these services thus giving the impression that the quantity surveyor is a reactive rather than a pro-active professional.

The most interesting and unexpected finding was the list of services expected from the professional quantity surveyor. Here it was found to be fundamentally different between the developers. One developer continued to list the conventional services delivered (estimating, bills of quantities and procurement documentation production, payment certificates, cost reporting etc.). The other developer displayed more what of what can be seen as the modern approach stating that the “only service required” (Chalwin-Milton, 2009) was for the quantity surveyor to interact with developers to deliver the optimal effective design. Then stated that the costing of such a design sets the way forward (Chalwin-Milton, 2009). This could be a change in relationship between the client and quantity surveyor with the quantity surveyor being seen as a design consultant with the more conventional services being seen as supplementary. The final question was only set to test the opinion of clients pertaining to quantity surveyors fulfilling the role of project manager or principal agents. Both agreed that quantity surveyors are capable in their opinion.

## **5.6.SUMMARY**

To summarise we have discussed the historical role of the quantity surveyor and found that the duties included:

- Measurement, Quantification and Preparation of Bills of Quantities
- Preparation of Contract Documents
- Cost Planning
- Cost Control
- Procurement Advice
- Contract Administration

All of which still form part of the duties of the “modern” quantity surveyor, the only difference is that the implementation of modern technology made it possible for previous reactive

documentation could now be produced pro-actively as to show influences of proposed design and design changes.

The changes to the industry methods now gave the opportunity for quantity surveyors to play a much bigger role in the design processes giving advice on cost matters usually based on past experience.

The client's perspective or rather opinion was tested in the form of a questionnaire. To summarise these findings one can say:

- Clients rate quantity surveyors and architects tied first in importance during early design phases.
- Unexpected differences in expected services were found.
- Both agreed that quantity surveyors possessed skills to influence the feasibility and viability of a construction project.
- Surprisingly very limited knowledge exists on the assessment methods for optimal and efficient design.
- Both agreed that professional quantity surveyors would be able to perform the duties of a project manager or principal agent.

### **5.7. CONCLUSION**

To conclude when the perceptions and opinions are investigated there will never be a concrete finding. People's opinions differ far too much to draw any clear concrete conclusion. The only conclusion that can be drawn is one that points to a change in perception of the developers in the importance of professional quantity surveyors and the services expected from them.

### **5.8. HYPOTHESIS TESTING**

Hypothesis as stated in chapter 1:

"Yes, the quantity surveyor can be seen as a design consultant. Maybe not a consultant as such but definitely as an advisor. Giving COST ADVICE to his employer and any design consultant involved with the construction project."

**AND**

“The perception of the role of a quantity surveyor greatly influences the relationship between the quantity surveyor and the client/employer. If the client gives the quantity surveyor sufficient support and authority, the quantity surveyor can contribute considerably through all of the project phases, starting with the concept design through final completion and signing of the final account.”

In this chapter it was shown that the experienced quantity surveyor cannot be seen as a design consultant per se. This consultant must be seen as a financial design consultant giving input and bettering the financial efficiency to derive an optimal design. Therefore the hypothesis was partially true.

The second hypothesis was found to be true and was entirely supported by the results of the questionnaire. This showed that when professional quantity surveyors received the opportunity and support of the client or employer they become of unequalled value.

# CHAPTER 6: SUMMARY, CONCLUSIONS AND RECOMMENDATIONS

---

## 6.1. BACKGROUND

This study was conducted to solve the main problem:

“What influence does design have on the profitability or feasibility of a construction project and in what manner can a quantity surveyor influence this concept?”

It was thought for the above mentioned main problem to be solved it was best to divide the main problem into the following sub problems:

1. How does architectural design influence the feasibility of a construction project?
2. How does structural design influence the feasibility of a construction project?
3. How does the design of specialist services influence the feasibility of a construction project?
4. Can a quantity surveyor be a design consultant without design responsibility?
5. How does the client and quantity surveyor relationship adapt with regards to the change in the role of the quantity surveyor?

Each of these sub problems needed to be individually researched and discussed as to derive to a conclusion on each. These conclusions were then individually used to test each of the hypotheses and derive whether these hypotheses were in fact true, partially true, probable, or false.

After concluding all research and testing of the hypotheses the result of these tests will be used to assess whether the main problem can now unequivocally be proven.

## 6.2. SUMMARY

Chapter two was an investigation into the influence of architectural design's influence on the feasibility of a construction project. The influence of the architectural design was found to be enormous. This was expected as the architect is responsible for most of the design done during the construction process.

During the study it was found that the modern day professional quantity surveyor can and will play a very important role in the design process. The quantity surveyor plays a proactive role in the cost management of the construction project. Quantity surveyors will comment on the efficiency and cost implications of the design, not leaving the designing architect to design an inefficient or uneconomical concept. When the quantity surveyor is not given this opportunity it may result in a much longer and tedious value engineering exercise after completion of the design.

Chapter three was a study of the influence of structural design on the feasibility of a construction project. The study showed that there needs to be good communication between the architect, structural engineer and quantity surveyor to ensure synergy between the architectural design, structural design and the influence of these designs on the feasibility.

The most important contribution made by this investigation was to show that the designers need to consider alternative design and construction methods as traditional methods may not be the most economical option and in some cases cause an entire project to seem unfeasible.

Chapter four was an investigation into the influence of the specialist services design on the feasibility of a construction project. In this study it was found that this is one of the sections of the design where the quantity surveyor can only have a limited contribution. Quantity surveyors can only comment on the choice of system to be used in the project, it is also true that this comments are based on past experience and not on technical knowledge. It is for this reason that the more experienced quantity surveyor may be of more assistance in this situation as a less experienced quantity surveyor may not have had the opportunity or exposure of working with alternative systems.

In chapter five an investigation was done into the client and quantity surveyor relationship with the quantity surveyor as a design consultant. Basically two major aspects were investigated, one the perceptions surrounding the professional quantity surveying profession and two how these perceptions influenced the general idea of developers in the industry.

In this chapter some interesting literature was found on the “change” in the quantity surveying field. As the literature was from the United States of America it showed that the whole world was finding a change in the profession. In the literature the writer showed the change in the industry by comparing the historical role of the quantity surveyor with the present and foreseeable future roles and services.

After the literature was discussed more research was needed to prove that the South-African quantity surveying profession was faced with the same challenges and changes as in the United States of America. Therefore a questionnaire was produced and handed to developers in the South-African construction industry, the results from this research supported the earlier theories and showed that although developers were aware of these changes and services other than the traditional they were not fully informed in how these “new” or “modern” services could be of advantage to them.

This investigation showed that the perception around the application of the professional quantity surveyor is changing and it is up to the professional quantity surveyors to market themselves accordingly. Another interesting finding was that developers were of the opinion that quantity surveyors are well equipped with necessary skills to oversee a project as the principal agent or project manager. This opens the door of opportunity for quantity surveyors seeking to diversify their service delivery.

Furthermore the questionnaire gave insight into the matter of the importance of having a professional quantity surveyor on the professional team of a development project. It was shown that the quantity surveyor ranked in joined first place together with architects. This is in strong contradiction with some views that the quantity surveying profession is a dying profession and that the quantity surveyor is obsolete.

### **6.3. CONCLUSION**

To conclude these sub problems are fundamental to the main problem/objective thus by answering these questions the main problem/objective will be solved or reached.

During the discussion on how the architectural design influences the feasibility of a construction project it managed to show that, this was in most probability the biggest contributing factor to cost and thus had the biggest influence on feasibility. In the discussion it was also found that certain assessment methods are available to the quantity surveyor to test the efficiency of the design and thereby bettering the feasibility of the entire project.

In the discussion of the influence of the structural design on feasibility of a construction project it was apparent that the focus fell on the communication between the architect, structural engineer and quantity surveyor. The need for the communication was put forth because of the interdependencies of the structural design and architectural design both influencing cost and thus feasibility. Furthermore the experienced quantity surveyor may be of great assistance to the design consultants as knowledge acquired from past experience may now be applied to deliver more economical designs or methods of construction.

The discussion of the influence of the specialist services design on the feasibility of a construction project found that this was the one sector where the quantity surveyor was of least assistance. It was found that the cost of such systems and designs impacted greatly on the feasibility of construction projects and that quantity surveyors could only comment on such systems and designs based on past experience.

The discussion relating to the quantity surveyor being a design consultant and the implications of this on the relationship between the developer/client and the quantity surveyor delivered interesting results. Developers/clients regard the importance of the quantity surveyor extremely high and are of opinion that in future more of the presently underutilised services may become more commonly used. In answering the sub problem it was found that the quantity surveyor play an integral part in the design stages as a consultant on economic design and therefore can be seen as a design consultant. As quantity surveyors have no formal training in the technical design they cannot have or take on any responsibility for the designs and therefore the suggestions made to alter design for cost purposes need to be tested and approved by relevant designers before implementation.

The developer quantity surveyor relationship is affected by this role of the quantity surveyor with the quantity surveyor changes from a reactive information producing consultant, to a proactive design consultant, delivering cost information proactively and thus ensuring an economically optimal and efficient design.

When the outcomes of these sub problems are used it is apparent that the main problem or objective was solved and met. As from the above discussions it can be found that design is one of the biggest, if not the single largest contributing factor to the cost of construction projects. This is because of the fact that cost is one of only two factors used to derive the feasibility of a construction project. Further it was shown that when developers or clients grant a quantity

surveyor sufficient opportunity and authority during the early design stages the resulting design will be a much more economical and feasible design.

#### **6.4. SUGGESTIONS FOR FURTHER RESEARCH**

During this study it was found that the field of optimising the design of construction projects is a relatively unexplored field with little information or research available. It was also shown that a lack of this information causes misperceptions in the industry pertaining to the functions of quantity surveyors and the importance of these functions. Further research into this field will increase awareness of the profession and its role thus giving the professional practice the opportunity to optimally apply their trade.



# BIBLIOGRAPHY

---

Chalwin-Milton L. 2009. Quote from questionnaire completed for the purposes for this study. (Completed 1 September 2009)

Coetzee H.S & Hauptfleisch A.C. 1999. Property Education Series: Building Practice 1. Technikon SA: Florida RSA

Finsen, E. 2005. The building contract: a commentary on the JBCC agreements, Cape Town: Juta.

Fowler LNB. 2009. Managing Director Bham Toyab Khan Pta (Inc). Interview

Hough D.E & Kratz C.G, 1983. Can Good Architecture Meet the Market Test? Journal of Urban Economics 14: 40-45

Kerzner H Ph.D. 2005. A Systems Approach to Planning, Scheduling and Controlling. Wiley & Sons Inc: Hoboken, New Jersey.

Moss J.2004. . The Future of Quantity Surveying. Presentation presented at the 2004 AACE Annual Meeting.

Nunnally S.W. 2004. Construction Methods and Management 6<sup>th</sup> Edition. New Jersey: Pearson Prentice Hall.

Pienaar S.J. 2004. Construction Cost Management Part 1: Estimating and Pricing Revision 5. Pretoria: University of Pretoria

Steward D.W. 2003. Understanding Structures : Analysis, Materials, Design 3<sup>rd</sup> Edition. Houndmills United Kingdom: Palgrave Macmillan.

Vandal, K.D & Lane, J.S. 1989. The Economics of Architecture and Urban Design: Some Preliminary Findings.

**INTERNET:**

[www.acehomeinspect.com](http://www.acehomeinspect.com) Access: 1 June

[www.architecturalguidance.blogspot.com](http://www.architecturalguidance.blogspot.com) Access: 1 June

[www.builderbill-diy-help.com](http://www.builderbill-diy-help.com) Access: 1 June

[www.concrete-forms.blogspot.com](http://www.concrete-forms.blogspot.com) Access: 1 June

[www.globalsecurity.org](http://www.globalsecurity.org) Access: 1 June

<http://osp.mans.edu.eg/deepfoundation/ch1.htm> Access: 1 June

[www.renovation-headquarters.com](http://www.renovation-headquarters.com) Access: 1 June

# TABLE OF CONTENTS

---

<b>CHAPTER 1: INTRODUCTION .....</b>	<b>1</b>
1.1 OVERVIEW OF THE TOPIC .....	4
1.2 STATEMENT OF THE MAIN PROBLEM/OBJECTIVE .....	4
1.3. STATEMENT OF THE SUB-PROBLEMS .....	4
1.3.1. How does architectural design influence the feasibility of a construction project? .....	4
1.3.2. How does structural design influence the feasibility of a construction project? .....	5
1.3.3. How does the design of specialist services influence the feasibility of a construction project? .....	5
1.3.4. Can a quantity surveyor be a design consultant without design responsibility and how does the client and quantity surveyor relationship adapt with regards to the change in the role of the quantity surveyor? .....	5
1.4. STATEMENT OF THE HYPOTHESES .....	6
1.5. DELIMITATIONS .....	6
1.6. DEFINITION OF TERMS .....	7
1.7. ASSUMPTIONS .....	7
1.8. IMPORTANCE OF STUDY .....	7
1.9. RESEARCH METHODOLOGY .....	8
<b>CHAPTER 2: INFLUENCE OF ARCHITECTUAL DESIGN ON FEASIBILITY OF A CONSTRUCTION PROJECT.....</b>	<b>9</b>
2.1. INTRODUCTION .....	9
2.2. THE ROLE OF AN ARCHITECT.....	9
2.3. ARCHITECTURAL DESIGN PRINCIPLES .....	10
2.3.1. <i>OPTIMAL USE OF LAND RIGHTS AND ZONING</i> .....	10
2.3.2. <i>EFFICIENCY OF DESIGN</i> .....	12
2.3.3. <i>GENERAL DESIGN</i> .....	13
2.3.3.1. SIZE AND SHAPE OF THE BUILDING .....	15
2.3.3.2. HEIGHT OF THE BUILDING.....	16
2.3.3.3. FLOOR TO CEILING HEIGHT .....	17
2.3.3.4. GRID DESIGN RELATED TO INTERGRATION OF THE WITH THE STRUCTURAL DESIGN. ....	18
2.3.3.5. FOYER AND ABLUTION DESIGN AND FINISHES .....	20

2.3.3.6.	FULLNESS OF PLAN.....	21
2.3.3.7.	FACADE DESIGN .....	23
2.3.3.8.	ROOF CONSTRUCTION .....	24
2.3.3.9.	PARKING REQUIREMENTS AND FACILITIES.....	25
2.3.3.10.	SITE CHARACTERISTICS .....	26
2.4.	SUMMARY .....	27
2.5.	CONCLUSION.....	29
2.6.	HYPOTHESIS TESTING.....	29
<b>CHAPTER 3: INFLUENCE OF STRUCTURAL DESIGN ON FEASIBILITY OF A CONSTRUCTION PROJECT .....</b>		<b>30</b>
3.1.	INTRODUCTION.....	30
3.2.	ROLE OF THE STRUCTURAL ENGINEER.....	30
3.3.	DESIGN COMPONENTS.....	32
3.3.1.	<i>FOUNDATIONS</i> .....	32
3.3.1.1.	STRIP FOOTINGS WITH CONCRETE PAD FOOTINGS FOR COLUMNS.....	32
3.3.1.2.	PILING.....	33
3.3.1.3.	RAFT OR MAT FOUNDATIONS.....	34
3.3.2.	<i>SUPERSTRUCTURE</i> .....	35
3.3.2.1.	COLUMNS.....	35
3.3.2.2.	STRUCTURAL WALLS AND BRACING .....	36
3.3.2.3.	BEAMS.....	37
3.3.2.4.	SLABS.....	39
3.3.3.	<i>ROOF STRUCTURE</i> .....	39
3.3.3.1.	STEEL TRUSSES & TIMBER TRUSSES .....	39
3.3.3.2.	CONCRETE ROOF SLABS .....	40
3.3.4.	<i>SUNDRY STEEL ITEMS</i> .....	41
3.4.	QUANTITY SURVEYOR'S INPUTS IN STRUCTURAL DESIGN.....	41
3.5.	SUMMARY .....	42
3.6.	CONCLUSION.....	43
3.7.	HYPOTHESIS TESTING.....	43
<b>CHAPTER 4: INFLUENCE OF SPECIALIST SERVICES DESIGN ON FEASIBILITY OF A CONSTRUCTION PROJECT .....</b>		<b>44</b>
4.1.	INTRODUCTION.....	44
4.2.	ROLE OF THE SPECIALIST ENGINEERS .....	44

4.2.1.	<i>ELECTRICAL ENGINEER</i> .....	44
4.2.2.	<i>MECHANICAL ENGINEER</i> .....	45
4.3.	DESIGN COMPONENTS OF SPECIALIST ENGINEERS .....	45
4.4.	QUANTITY SURVEYOR'S INPUTS IN STUCTURAL DESIGN .....	49
4.5.	SUMMARY .....	50
4.6.	CONCLUSION.....	51
4.7.	HYPOTHESIS TESTING.....	51
<b>CHAPTER 5: CLIENT AND QUANTITY SURVEYOR RELATIONSHIP WITH QUANTITY SURVEYOR AS DESIGN CONSULTANT.....</b>		<b>52</b>
5.1.	INTRODUCTION .....	52
5.2.	HISTORIC ROLE OF THE QUANTITY SURVEYOR .....	52
5.3.	CURRENT AND FUTURE ROLES OF THE QUANTITY SURVEYOR.....	53
5.4.	CALLENGES TO THE CHANGE IN ROLES.....	54
5.5.	THE EMPLOYER'S (CLIENT'S) PERSPECTIVE .....	55
5.6.	SUMMARY .....	57
5.7.	CONCLUSION.....	58
5.8.	HYPOTHESIS TESTING.....	58
<b>CHAPTER 6: SUMMARY, CONCLUSIONS AND RECOMMENDATIONS.....</b>		<b>60</b>
6.1.	BACKGROUND .....	60
6.2.	SUMMARY .....	61
6.3.	CONCLUSION.....	62
6.4.	SUGGESTIONS FOR FURTHER RESEARCH .....	64
<b>BIBLIOGRAPHY .....</b>		<b>65</b>

# TABLE OF FIGURES

---

<i>Figure 1: Demonstration of the floor to wall area ratios of two different shapes of buildings. .</i>	16
<i>Figure 2: Ideal Grid design for economic structure .....</i>	19
<i>Figure 3: Ideal Grid design for economic structure of a modern grid design.....</i>	20
<i>Figure 4: Building A, a building of 450m<sup>2</sup> with 60m of internal divisions .....</i>	22
<i>Figure 5: Building B, a building of 450m<sup>2</sup> containing 90m of internal divisions .....</i>	22
<i>Figure 6: Graphic illustration of the increase in cost to implement changes to the design throughout the construction process. ....</i>	26
<i>Figure 7: Graphic illustration of the placement of steel reinforcement in concrete components .....</i>	31
<i>Figure 8: Illustration of a strip footing/foundation under a wall.....</i>	33
<i>Figure 9: Pile foundations .....</i>	34
<i>Figure 10: Raft or Mat Foundations.....</i>	35
<i>Figure 11: Concrete column and formwork. ....</i>	36
<i>Figure 12: Sketch illustrations of the implementation of structural walls and bracing .....</i>	37
<i>Figure 13: Sketch illustration of reinforced concrete beam .....</i>	38
<i>Figure 14: Sketch illustration of concrete slab spanning between steel I beams .....</i>	38
<i>Figure 15: Photo of slab formwork, reinforcement bars and electrical conduits ready for casting of concrete .....</i>	39
<i>Figure 16: Typical timber roof truss. ....</i>	40