

# THE USE OF MODERN ROUNDABOUTS ON PROVINCIAL ROADS

Dr John Sampson and Mr Mike Meijer\*

Jeffares & Green Inc., P O Box 1109, Sunninghill 2157

\*Gautrans, Private Bag X82, Marshalltown 2107

## 1. INTRODUCTION

Traffic circles or roundabouts, as an alternative intersection traffic control device in South Africa, have traditionally not been favourably received. Nevertheless, modern roundabouts are becoming more common throughout the world. Internationally, roundabouts have been shown to be the safest form of traffic control which is of particular importance here in South Africa. Furthermore, roundabouts have less delay than stop or traffic signal control in a wide range of conditions.

This report summarises an investigation which was undertaken for Gautrans. The investigation undertaken includes a literature study, interviews with researchers and practitioners, a technical evaluation and a computer simulation. The detailed findings are contained in a report "Traffic Circles on K-routes: Working Document" prepared by the PWV Consortium in November 1998.

## 2. TERMINOLOGY

The term "traffic circle" is still widely used in South Africa. The United States, Europe (Britain, France, Germany) and Australia prefer the term roundabout. The USA term rotary seems to have been discarded, as has "ring junction". In modern literature, "traffic circle" is a now outdated term. In fact, in recent references a distinction is drawn between "old traffic circles" and "modern roundabouts".

Therefore in order to bring South Africa in line with the international traffic engineering fraternity, the term roundabout will be used whenever the more modern facility is referred to in this report.

Two further terms used in the literature which can lead to confusion are ICD and CID. The ICD is the inscribed circle diameter, or the outer diameter of a roundabout. The CID is the central island diameter, or inner diameter. The terms inner and outer diameter are preferred in this report.

### **3. OLD TRAFFIC CIRCLES VERSES MODERN ROUNDABOUTS**

The differences between “old traffic circles” and “modern roundabouts” are:

1. Approach roads on old circles entered tangentially, allowing high speed entry. Modern roundabouts have a tight entry radius to reduce speed.
2. It follows that, with older circles, vehicles were not necessarily deflected from their path on entry. This is an essential element in modern roundabouts.
3. Modern roundabouts reduce the entry radius in order to slow entering vehicles, and flare the exit radius to allow faster, easier exit. This was rarely provided in old circles.
4. Modern roundabouts generally require a raised splitter island between entry and exit lanes.
5. Modern roundabouts work on gap acceptance principles. The “give way to the right” rule applies and vehicles in the circulating roadway always have priority. Some of the older circles were designed on weaving principles.

### **4. TYPES OF ROUNDABOUTS**

Roundabouts can be further subdivided by size. The main size distinction is between mini-circles and conventional or standard modern roundabouts.

The term mini-“circle” is deliberately used, as it does not comply with modern roundabout principles. In South Africa “mini-circles” are often seen in urban areas. Here users treat priority on a “first-come, first-served” basis. The “give-way to the right” rule only applies when two vehicles reach the mini-circle at the same time.

Mini-circles generally have an outer diameter of 25 m or less and an inner diameter of around 2 m to 4 m. Because heavy vehicles are unable to track around mini-circles, the central island must be painted or only slightly raised to allow vehicles to drive over them. Typical mini-circles are illustrated in Figure 1.

All modern roundabouts have an outer diameter of 26 m or greater. Most references require a minimum outside diameter of 28 m or 30 m and a tracking width of 7,5 m or wider, as these are the minimum dimensions required to cater for large trucks. Roundabouts larger than the minimum are used to increase capacity.

Compact roundabouts have single lane approaches and single lane circulatory roadways. They can be described therefore as modern compact single lane roundabouts. The smallest compact roundabout would typically have an outer diameter of 28 m and an inner diameter of 12 m. This is illustrated in Figure 2. In rural areas, the outside diameter of compact roundabouts can be anything from 35 m to 45 m. The larger diameter allows for slightly higher circulatory speeds and a narrower paved width of between 6,0 and 6,5 m. A typical “compact” roundabout in a rural area might then be 40 m outside diameter and 28 m inside diameter.

Roundabouts with more than one lane on an approach, or with more than one circulatory lane or with more than four approach legs, generally have to have a larger outer diameter. A standard or conventional roundabout with approach lanes of varying width and number is illustrated in Figure 3. The outer diameter is 35 m.

Three large multi-lane roundabouts, with varying road marking options, are shown in Figure 4. The outside diameter of these is 72 m.

Very large, multi-lane, multi-leg roundabouts are known to exist overseas, the most famous is that on the Champs Elysees. An example of a very large circle currently being constructed in South Africa is given in Figure 5.

The five examples each further illustrate other principles, namely:

- Figure 1:** Road signs, road marking and mountable island construction details
- Figure 2:** Typical dimensions including road reserves, and road surfacing options
- Figure 3:** Terminology, as well as the principle of deflection on entry but higher speed, easy exit
- Figure 4:** Road marking alternatives
- Figure 5:** A mix of road uses, multi-leg approaches and exclusive lanes.

## 5. CAPACITY

In the 1960s traffic circles fell out of favour in the United States, Germany and South Africa and possibly in other countries. At that time, a number of traffic circle intersections were removed and replaced with traffic signals. The reasons why this happened elsewhere are unclear, but in Johannesburg the dominant reason for replacing circles was because of capacity problems. During peak hours pointsmen became necessary on each approach to the old circles and the replacement traffic signal proved to be a more efficient and higher capacity solution.

Recent research has however shown that while roundabouts do not have the ultimate capacity of a traffic signal, they do have a much greater capacity than two-way or all-way stop controls and can operate well at intersections which would otherwise require the installation of traffic signals.

The capacity of roundabouts depends to a degree on the country where they operate, with the United Kingdom, where roundabouts are more common, indicating the highest capacity. Fairly typical capacity ranges reported are as follows:

**Table 1: Roundabout Capacities**

	<b>Total Capacity of all Approaches</b>	<b>Single Lane Approach Capacity</b>	<b>Daily Capacity</b>
	<b>(veh/hr)</b>	<b>(veh/hr)</b>	<b>(ADT)</b>
Single lane roundabouts	1 500 comfortable 2 500 capacity (2 100 to 2 800 range)	0 to 1 500 vph depending on circulating volume	15 000 to 25 000
Two-lane roundabouts	3 600 practical capacity 4 000 ultimate capacity	1 400 (Germany)	30 000 to 40 000
Multi-lane roundabouts	4 000 to 6 000 7 500 max. claimed	-	-

In a simulation exercise carried out as part of this study, the delay at two-way stops, roundabouts and traffic signals was simulated using both SIDRA (Australia) and SIMTRA (South Africa). The results, indicating the intersection control which gave the lowest overall (total) delay at two-lane per approach intersections, are given in Figure 6. The area indicated

as “exceeds capacity of intersections with two-lane approaches” is where delay becomes excessive and/or the simulation results are unstable.

The “main road two-way hourly volume” is the combined east-west approach volume which was tested using different splits. The “side road two-way hourly volume” was modelled similarly. Adding the main road and side road volumes would give the total approach volume.

The roundabout capacity was affected by directional splits and turning percentages in that the higher the circulating volume became, the lower the capacity that resulted. The results do tend to confirm the capacity ranges reported above, with a peak capacity of the roundabout at around 3 000 to 4 000 depending on the volume conditions.

It should be noted however that field studies of roundabouts seldom find volumes reaching their theoretical capacities. In practice entry volumes of around 1 000 vehicles/hour/lane are amongst the highest reported on multi-lane roundabouts. It is surmised that gap acceptance theory does not fully explain the behaviour of motorists, but more work is needed before conclusions can be made.

## **6. SAFETY**

Of all the benefits claimed for modern roundabouts, improved safety is the one which is most consistently and most convincingly indicated. Typically collision numbers and severity of collisions at roundabouts are at around 30% to 50% of equivalent intersections with traffic signal control.

Pedestrian and cyclist safety, often perceived as a potential problem at roundabouts, is also no worse and usually better than at other control types.

As a further protection for pedestrians and cyclists, splitter islands are recommended at modern roundabouts. These are shown at all the roundabouts illustrated in Figures 2 to 5, discussed earlier. Figure 2 illustrates a further option of siting the pedestrian crossing at approximately 6 m, or one car length back from the yield line to reduce vehicular/pedestrian conflict.

The major reason for the improved safety condition is the reduced speed at which modern roundabouts operate. Speeds in the circulating roadway are typically 30 to 40 km/hr. In the few cases where accident problems at circles were noted, these were always at mini-circles or old traffic circles where the design of the circle did not guarantee speed reductions.

In order to achieve the safety improvement, the principles of modern roundabouts must be adhered to. In addition, in field studies in South Africa, it was noted that the left lane of two-lane exits must be marked as a compulsory left turn. While this does not seem to be a requirement in Europe (Figure 3, Figure 4a and 4b), safety problems do arise locally without it.

## 7. ENVIRONMENTAL IMPACT

Environmentally and aesthetically, traffic circles are a more pleasant option than conventional stop or traffic signal junctions. Such is their general attractiveness, that roundabouts are often used in residential or office estates for environmental reasons without regard to their traffic control merits.

Because of their prominent location at the centre of important junctions, roundabouts also lend themselves to be used for the display of fountains, statues or monuments. However, shrubs or high landscaping must not be allowed where the central island diameter is less than 10 m or where visibility is adversely affected.

## 8. ROAD RESERVES

The minimum space required for a modern roundabout is 28 m for the outer diameter, to which a further 3 m verge should be added for pedestrian sidewalks and underground services on either side. The resulting 34 m dimension cannot be accommodated in road reserves of 24 m or less without the provision of splays on all four corners. (Figure 2).

The splays required vary with the road reserve and are approximately as follows:

**Table 2: Splay Dimensions Required for Compact Roundabouts with Minimum Dimensions**

<b>Road Reserves of Intersecting Roads</b>	<b>Minimum Splay Dimensions</b>	<b>Total Area m<sup>2</sup></b>
16 m x 16 m	8 m x 8 m	128
20 m x 20 m	4 m x 4 m	32
25 m x 25 m	0 m x 0 m	0

The acquisition of these splays, where they do not already exist, adds to the cost and difficulty in providing roundabouts and is often a reason for not considering roundabouts as a solution. This is rarely a problem on Provincial Roads however, as adequate road reserves are available.

## 9. COSTS AND MAINTENANCE

The cost elements can be divided into three sections:

- 1. Road User Costs**  
Delay and congestion costs (fuel, time)  
Accident costs.
- 2. Maintenance Costs**  
Routine  
Special.
- 3. Capital Costs**  
Land acquisition  
Construction.

Dealing with these in order, it has been shown that correctly located roundabouts will have substantially lower accident costs as well as less delay and lower road user costs than equivalent devices.

Maintenance costs of circles are low and the pavement and drainage maintenance can be done in the normal course of routine maintenance. There may be landscaping maintenance costs to be incurred, which might not be the case with conventional intersections, but this cost is related to the improved environmental conditions and not to the roundabout operation.

Construction costs of converting an existing stop controlled intersection to a modern roundabout have been estimated between R54 000 and R107 000 (1999). If the conversion is done for safety or capacity reasons, this cost is very reasonable and much less than alternatives such as traffic signals. Furthermore, were the roundabouts being considered as part of original designs, cost savings could be achieved.

A further consideration is the cost of having to remove the roundabout in future, should it become necessary to convert to a traffic signal. It has been shown (Figure 6) that roundabouts have a capacity similar to traffic signals in certain circumstances and therefore reduce the need for signals. If the intersection becomes sufficiently busy that the roundabout can no longer cope, it would in any event be likely that the original intersection would need to have been widened and improved to provide adequate traffic signal capacity. Removing the roundabout would be a marginal cost. The cost of providing the roundabout would have been justified by user savings up to that point. Furthermore, if the later reconversion was planned, the original road surface under the central island could have been left undisturbed and could be reused.

## 10. SUITABLE ROUNDABOUT LOCATIONS

While a roundabout is sufficiently flexible to be used at most intersections, certain locations lend themselves to roundabouts while others do not.

Table 4 is suggested as a guide to the general applicability of roundabouts to various functional road classifications.

**Table 4: Roundabout Applicability to Cross Roads (Guideline)**

	Arterial Rd	Minor-Arterial Rd	Collector Rd	Local Str
Arterial Road	B	B	C	C
Sub-Arterial Rd	-	B	B	C
Collector Rd	-	-	A	B
Local Str	-	-	-	A
Notation: A: Likely to be an appropriate treatment B: May be an appropriate treatment C: Not likely to be an appropriate treatment				

The best locations are as follows:

1. Intersections where safety would otherwise be a problem.
2. Intersections where environmental enhancement or landscaping is required.

3. Intersections where traffic signal maintenance or the availability of power supply is a problem.
4. Where signals are required but cannot be afforded.
5. Where permanent, maintenance free control without enforcement is necessary.
6. Where there are four-way or multi-way stops.
7. Where urban and rural roads meet (eg. entrance to towns) or where commercial/industrial and residential areas meet.
8. Where the road standard or speed limit changes (eg. where a major road changes to collector/local status).
9. In suburban areas where traffic calming is required.
10. At intersections with high turning movements.
11. At intersections with more than four legs.
12. At Y-junctions or other junctions with awkward geometry (eg. sharp change in direction).
13. With other circles in a network where intersection spacing is too close for signal coordination to be achieved.
14. Where U-turns are prevalent or desirable.

Where three or more phases are required at traffic signals, roundabouts should be considered.

## **11. UNSUITABLE ROUNDABOUT LOCATIONS**

Roundabouts equalise the priority of all approach roads. No matter how minor the intersecting road may be, it is afforded the same priority on entry as any of the major routes. Furthermore all vehicles must slow and take gaps on approaching the roundabout and priority cannot be given to any movement without violating the roundabout operational principles (eg. once traffic signals or stop streets are put on roundabouts, they cease to operate as roundabouts).

Mini-circles in particular must be avoided where the major road traffic is such that it will “force” priority. If heavy main road traffic makes the minor road or right turning traffic stop and give way, even though the circle theoretically gives the minor traffic priority, a dangerous situation arises.

Unsuitable locations for roundabouts are:

1. Where minor crossroads enter major routes when a stop street would suffice.
2. In signalised co-ordinated networks where they would break up the platoon flow.
3. Where traffic signals will soon be required.

As is the case of all intersections, roundabouts should be avoided on roads with steep slopes or where the intersection is not visible. Longer ‘flat’ areas are required for roundabouts compared with other intersection types, making them less suitable on steep grades.

## **12. ROAD MARKING AND SIGNS**

Adequate warning signs should be erected on the approach to roundabouts (Figure 1). It is further recommended that chevrons (W408) be erected on the central island opposite approach roads.

Each approach leg to the roundabout should have yield markings painted along the line of the outer diameter. This defines the circle and helps visibility for motorists waiting on multi-lane approaches. Arrows are also good to prevent wrong way movements. Road marking along the diameter at exit lanes is optional but usually not required. The left lane on two-lane exits should however be marked as a compulsory left turn.

Lane-markings, arrows and hatching on the circulating roadway is optional, but usually not recommended for small roundabouts. Figures 1 to 5 give different options, with Figures 4 and 5 providing examples of ways of marking multi-lane circles with multiple exit lanes. Each lane in multi-lane roundabouts should be painted with the exit route number.

Direction signs at each of the exits of larger circles are also recommended.

## **13. LIGHTING**

Lighting of roundabouts is preferred and generally recommended. An attractive option is to provide low level lighting shining up into bushes, fountains or statues on the central island. This lighting can be different colours. In rural areas where lighting is not possible, chevrons must be used.

## **14. CONCLUSION**

Modern roundabouts are a flexible, efficient, safe and desirable form of intersection control. Their major advantages are improved safety and the ability to reduce overall delay over a wide range of peak and off-peak traffic flows. They are self-regulating and can be implemented at reasonable cost.

They are suitable for use under light to medium traffic flow conditions on roads comprising no more than two approaching lanes including local streets, arterial roads, and the initial phases of K-routes. They are not recommended for implementation on six lane roadways.

While a warrant for roundabouts is not defined in this report, Figure 6 can be used as a reliable guideline for the conditions under which roundabouts operate best. Roundabouts are not a suitable solution beyond these volumes. Table 4 is also useful as a general guideline for where roundabouts can be considered.

The overall conclusion of this report is that, in the right circumstances, modern roundabouts are a safe, efficient and effective form of traffic control.



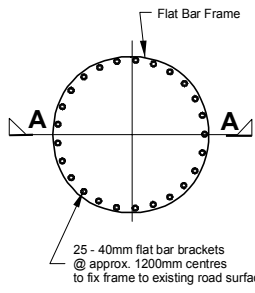
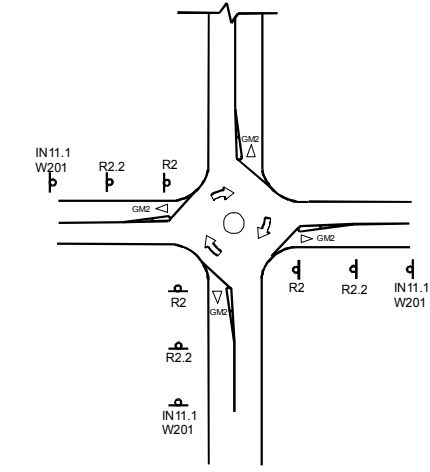
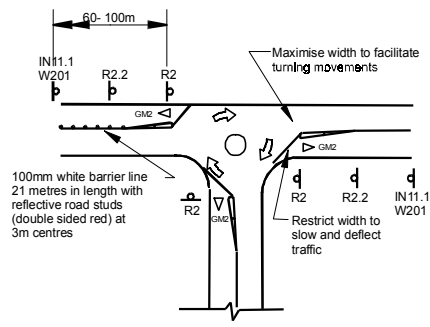

**CENTRAL RAISED ISLAND DETAIL**  
Not to Scale

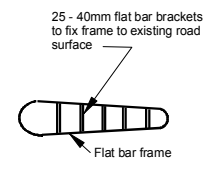
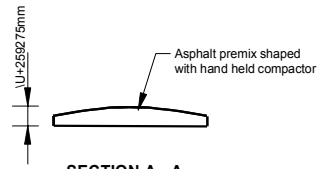

**APPROACH ISLAND FRAME**  
Not to Scale

Outer Diameter: 15,0m - 20,0m  
Inner Diameter: 3,0m - 4,0m

Recreated from:  
Johannesburg City Council



# MINI CIRCLE

## Illustrating Island Construction, Signs and Markings

**FIGURE 1**

SCALE 1:1000

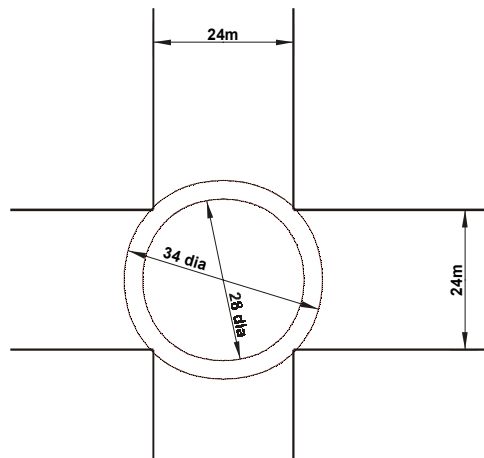
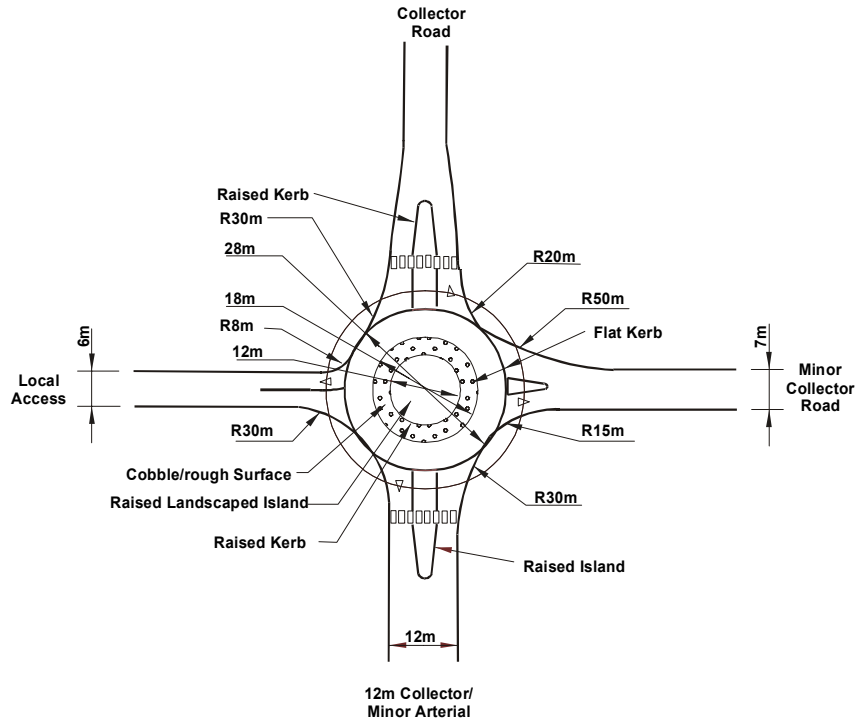

Minimum Road Reserve without Splays

Outer Diameter: 28,0m  
Inner Diameter: 12,0m

Recreated from:  
Photograph  
Brilon and Vandehay  
(Germany) ITE Journal Nov. 1998



## COMPACT ROUNDABOUT

### Illustrating Minimum Dimensions for Modern Roundabouts

FIGURE 2

SCALE 1:1000

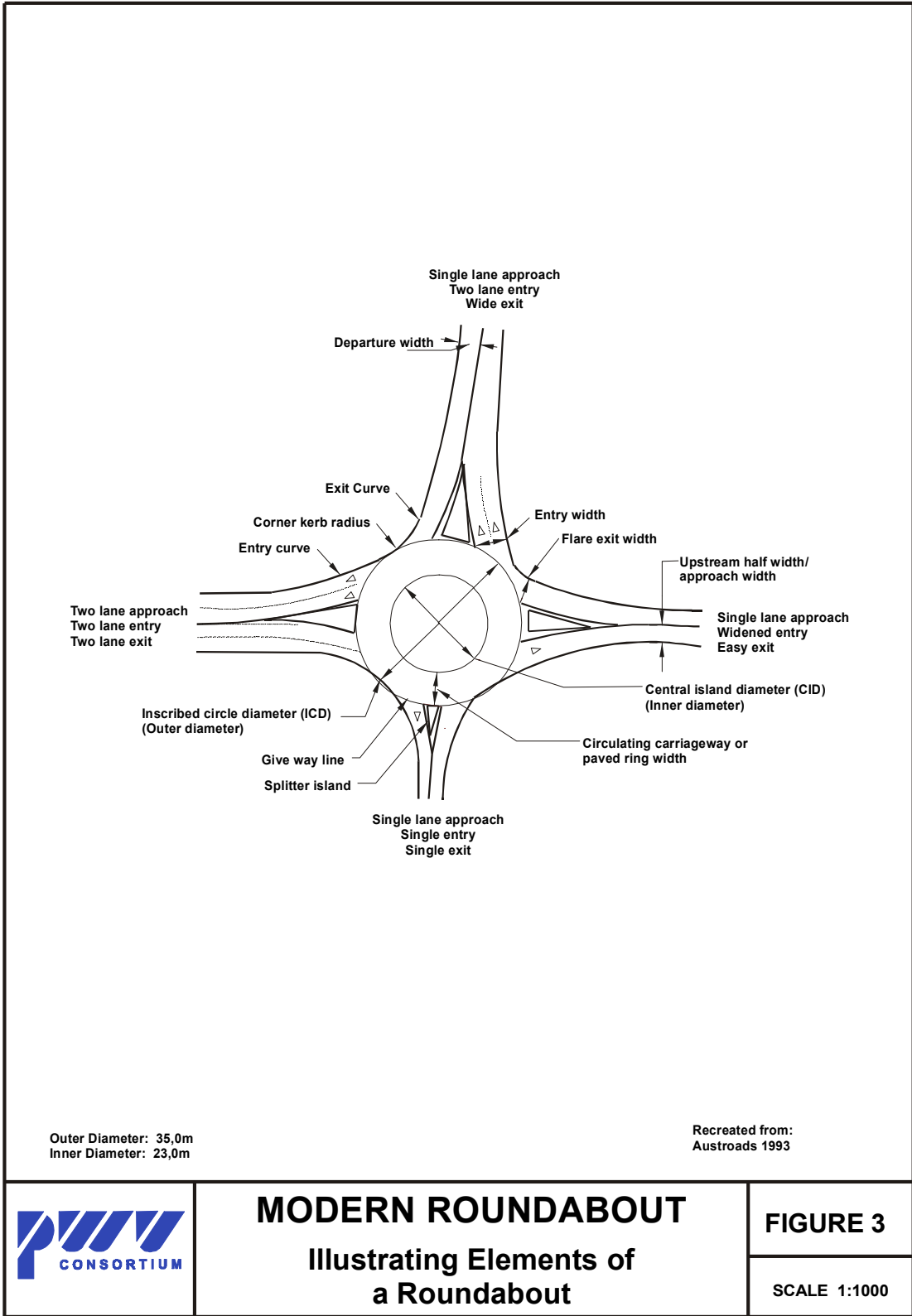

**MODERN ROUNDABOUT**  
**Illustrating Elements of**  
**a Roundabout**

**FIGURE 3**  
 SCALE 1:1000

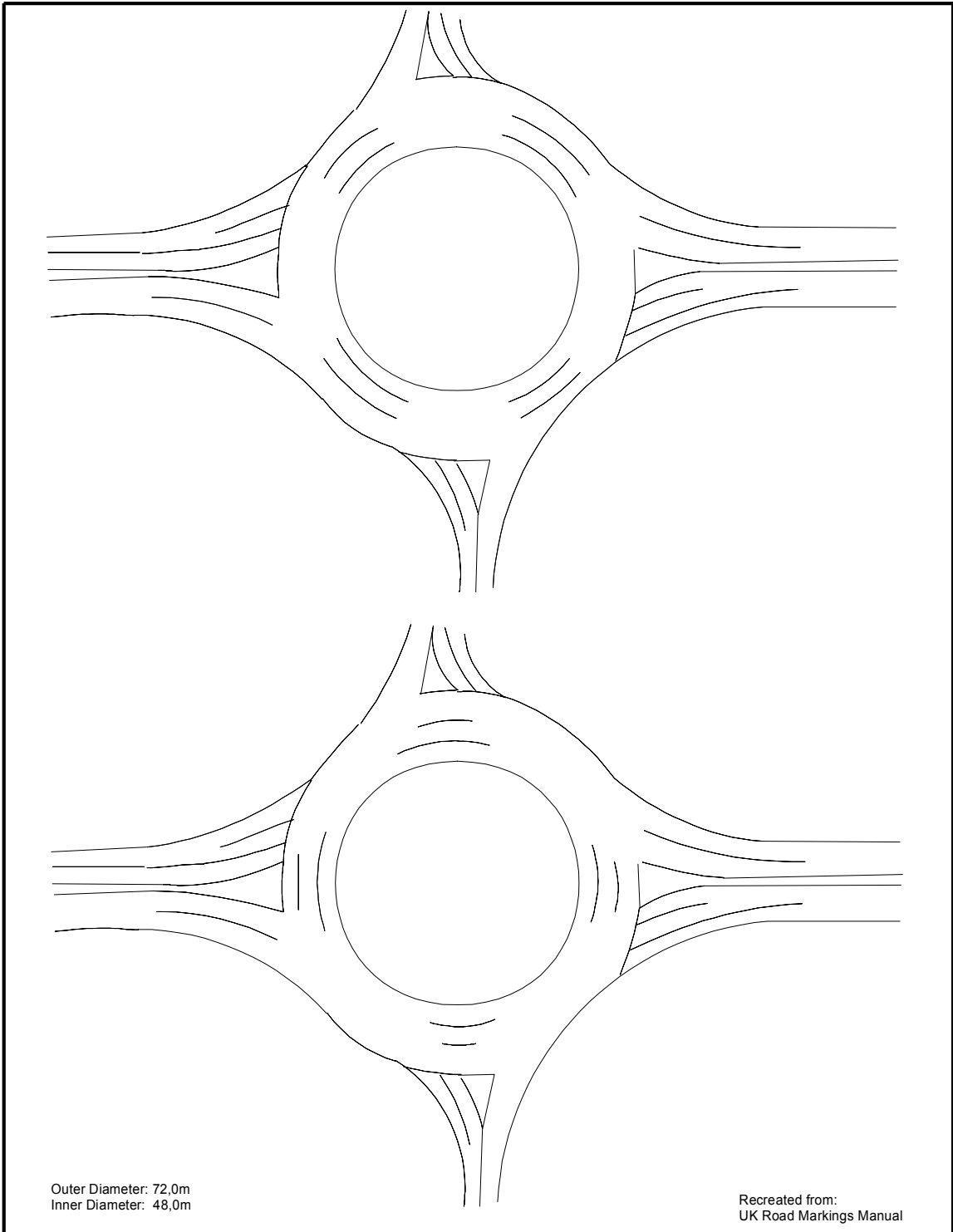

Outer Diameter: 72,0m  
Inner Diameter: 48,0m

Recreated from:  
UK Road Markings Manual



# LARGE ROUNDABOUT

## Illustrating Road Marking Options

FIGURE 4a/b

SCALE 1:1000

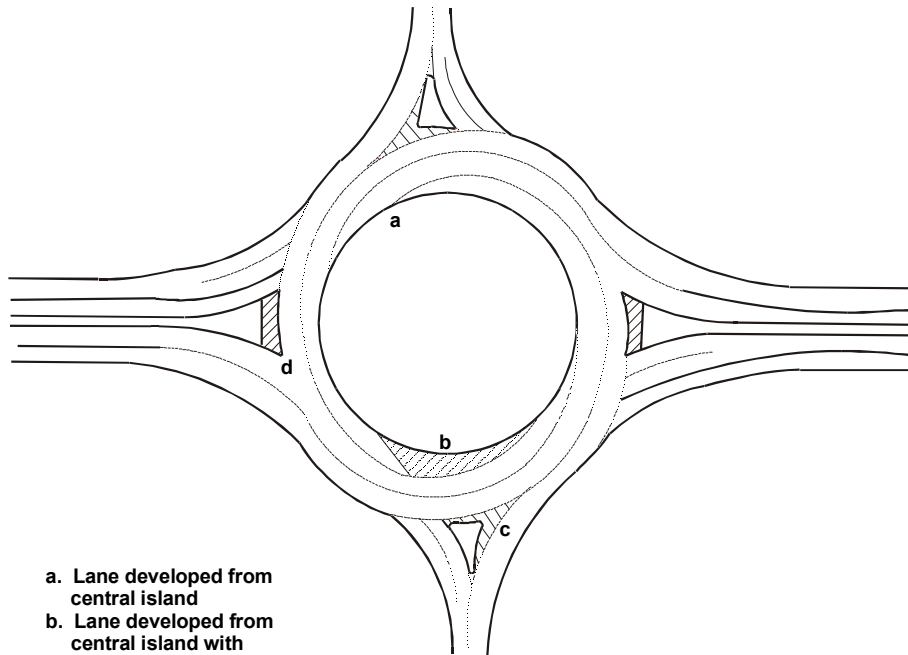

- a. Lane developed from central island
- b. Lane developed from central island with hatch markings
- c. Outermost lane leads directly off
- d. Driver in middle lane afforded a choice of exit

Outer Diameter: 72,0m  
Inner Diameter: 48,0m

Recreated from:  
UK Road Markings Manual



## LARGE ROUNDABOUT

### Illustrating Road Marking Options

**FIGURE 4c**

SCALE 1:1000

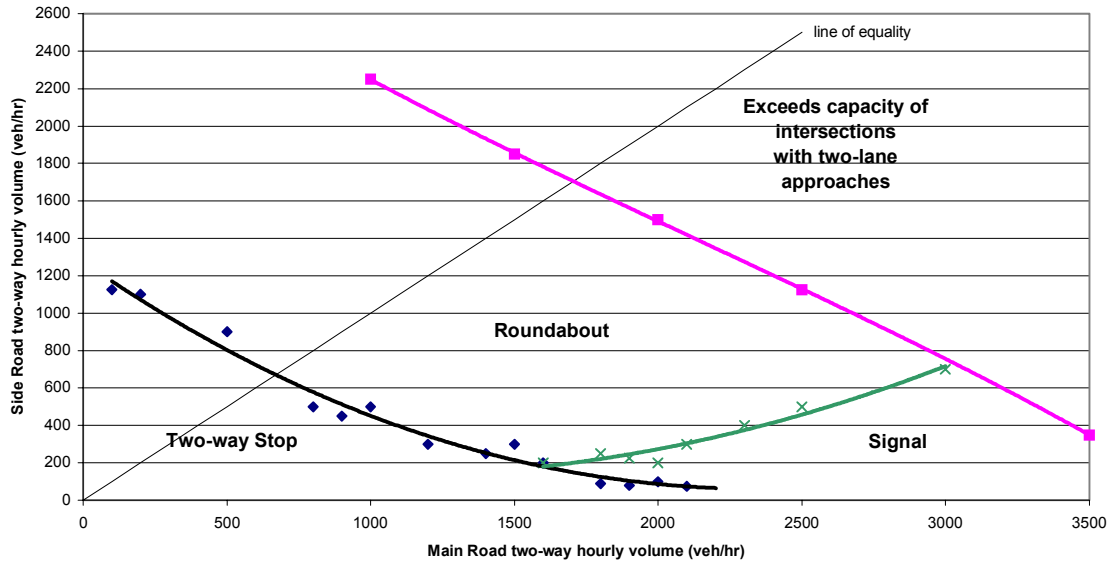

**Figure 6:** Volume Range over which indicated Control minimizes Delay (modelled using SIDRA and SIMTRA)

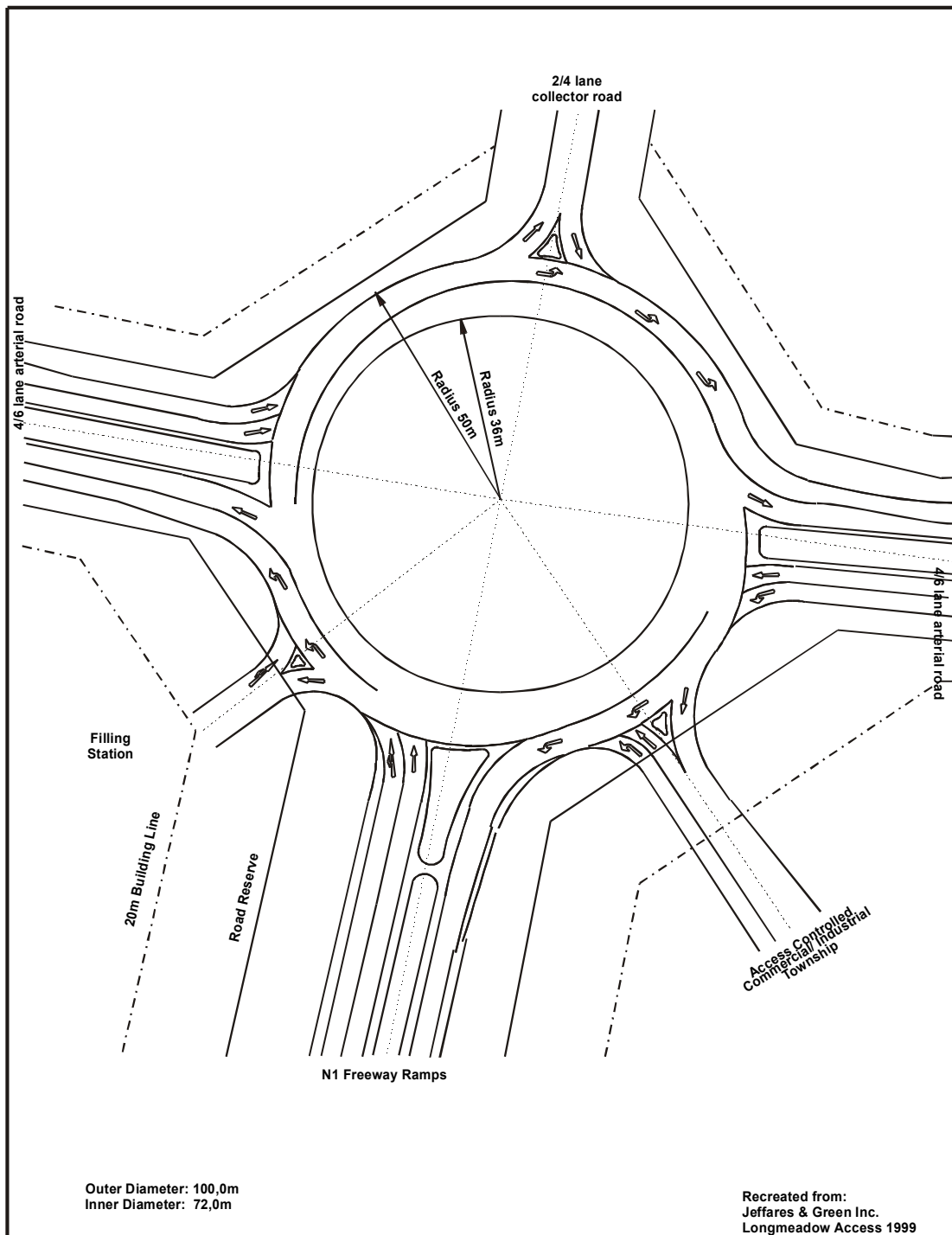

	<p><b>MULTI APPROACH CIRCLE</b></p> <p><b>Illustrating Multiple Entering Roadways of Different Standards</b></p>	<p><b>FIGURE 5</b></p> <hr/> <p>SCALE 1:1000</p>
---	--	--

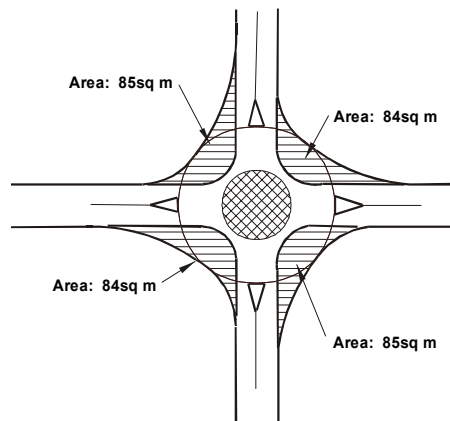

Outer Diameter: 28,0m  
 Inner Diameter: 12,0m

Entry Radius: 10,0m  
 Exit Radius: 30,0m



Reduced surfacing =  $113m \setminus U + 2593$

Added surfacing =  $338m \setminus U + 2593$



## COMPACT ROUNDABOUT

### Illustrating Surfacing Areas Required for Conversion from Narrow Intersection

**FIGURE 7**

SCALE 1:1000



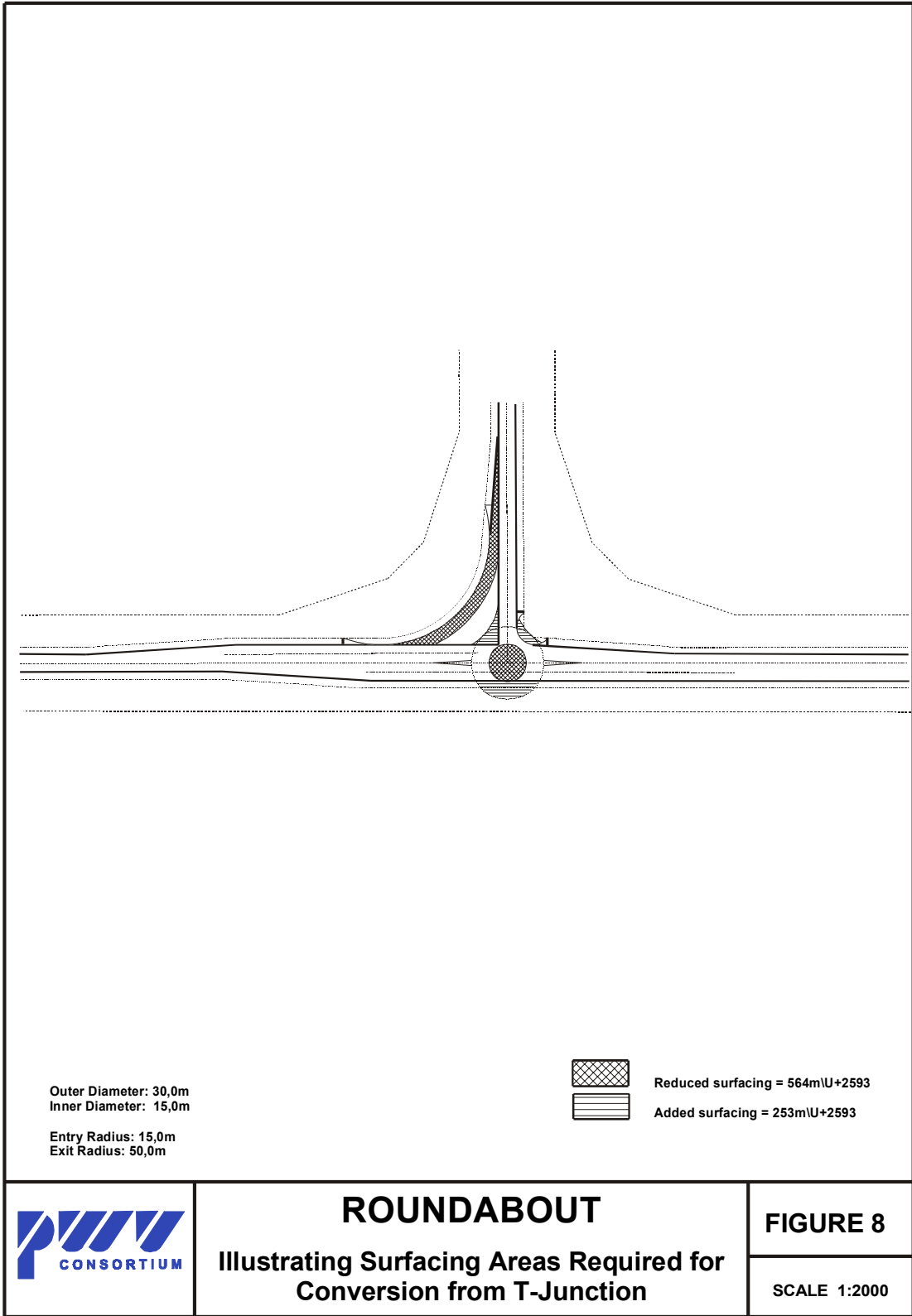

**ROUNDAABOUT**  
 Illustrating Surfacing Areas Required for  
 Conversion from T-Junction

**FIGURE 8**  
 SCALE 1:2000

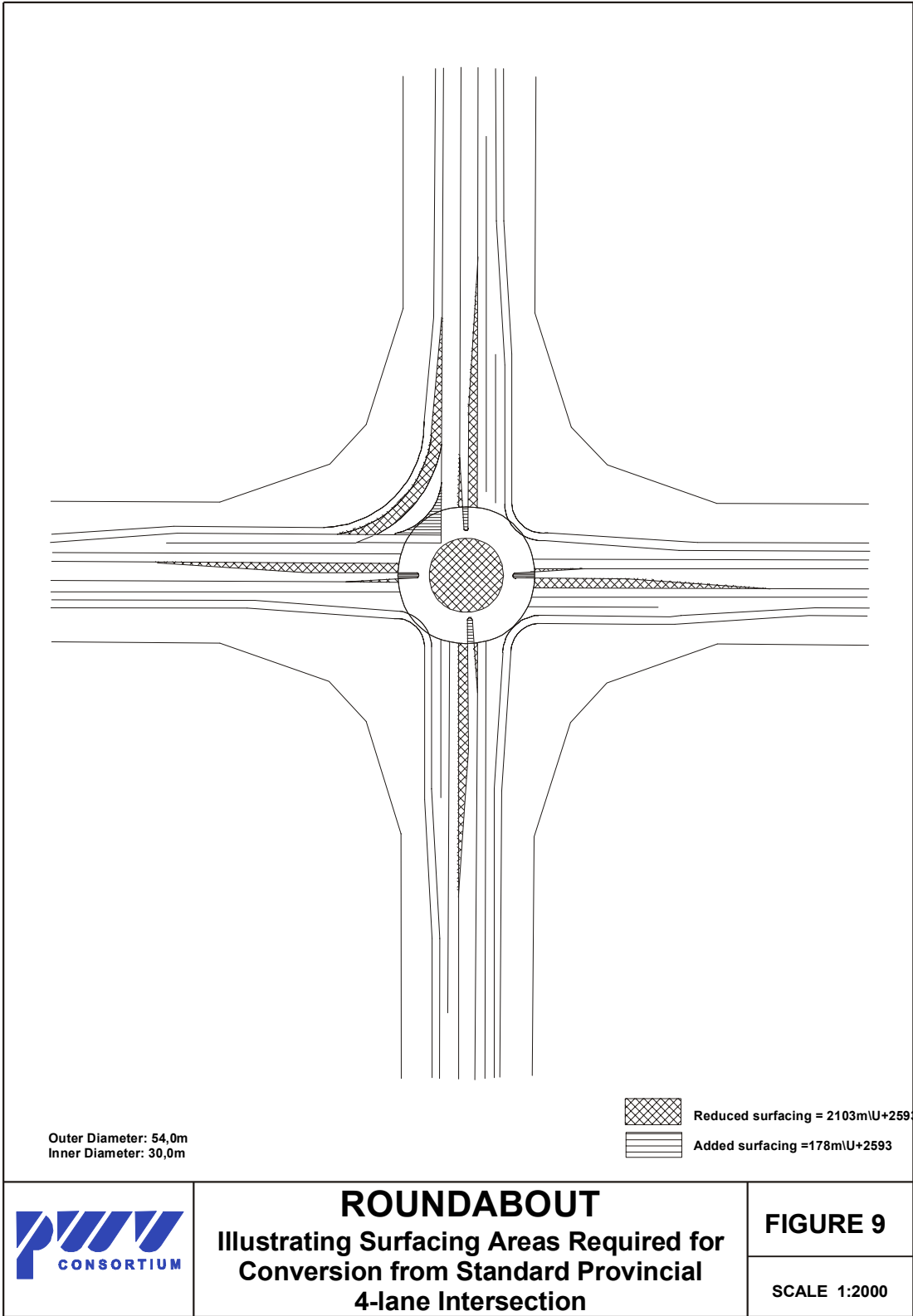

# THE USE OF MODERN ROUNDABOUTS ON PROVINCIAL ROADS

Dr John Sampson, PWV Consortium  
c/o Jeffares & Green Inc., P O Box 1109, Sunninghill 2157  
Tel: (011) 807-0660, Fax: (011) 807-1607, E-mail: [johns@jandg.co.za](mailto:johns@jandg.co.za)

## CV SUMMARY

Dr. John Sampson is a Professional Engineer, BSc (Civil Engineering) (Witwatersrand 1971), MS (Transportation Engineering) (California, Berkeley 1975), BCom (Economics with distinction, Industrial Psychology) (UNISA 1977), PhD (Witwatersrand 1992), is a Fellow of the SA Institute of Civil Engineers (FSAICE), a Member of the SA Association of Consulting Engineers (MSAACE), a member of the Institute of Transportation Engineers (MITE) and a Member of the Institute of Waste Management (MIWM). His PhD thesis was entitled "Warrants for Traffic Signals". He holds Certificates in Project Management, Traffic Control and various other diplomas.

Dr Sampson spent twenty-one years with the (then) City Engineer's Department of Johannesburg where he rose to the position of Deputy City Engineer. Most of that time was spent in the Road Planning and Traffic Engineering Branch of the Department. He then joined the Urban Foundation as General Manager (Housing), FHA Homes.

In 1990, he was appointed as a partner of Jeffares & Green and a Director of Jeffares and Green Inc. where he is in charge of the Traffic, Transportation and Environmental Divisions in Greater Johannesburg. He has lectured at the University of the Witwatersrand and from 1995 to 1998, he was "Extra Ordinary Professor" in the Civil Engineering Department of the University of Pretoria. He serves on the Management Committee and Board of Jeffares & Green.

Dr Sampson's main fields of specialization include transportation planning, transportation engineering, economic analysis of projects, inter-modal infrastructural development, traffic engineering (traffic impacts, parking, passenger transport, road and intersection design, traffic control, road markings and signs), and project management.