

FLOW PATTERNS IN ECCENTRIC STIRRED VESSELS

Hernández-Maya, J.C.¹, Brito-Herrera¹, J.M., Hernández², G., Ramos, E.² and Ascanio, G.^{1*}

*Author for correspondence

¹CCADET, Universidad Nacional Autónoma de México, Mexico City, Mexico

²CIE, Universidad Nacional Autónoma de México, Temixco, Mexico

E-mail: gabriel.ascanio@ccadet.unam.mx

ABSTRACT

Mixing in stirred vessels is commonly carried at low to moderate Reynolds number. Under steady stirring conditions (impeller centered with respect to the vessel centerline and rotating in one direction) well mixed regions around the impeller and isolated regions far from the impeller are formed into the vessel. Such regions can be gradually vanished if the flow is continuously perturbed, which in some cases can be done by displacing the impeller from the vessel centerline. This paper describes an experimental analysis based on Newtonian flow fields observed by particle image velocimetry in a stirred vessel with the impeller placed eccentrically with respect to the vessel centerline.

INTRODUCTION

It is quite difficult to think in an industrial process without considering mixing. Such a unit operation is found in numerous applications like fermentation, pigment or powder dispersion, emulsions, personal care products, etc. The typical configuration for liquid mixing in stirred vessels consists of a rotating impeller placed in the centerline of the stirred vessel. Although, mixing has been perceived as a mature technology, the process is commonly low cost-effective to use due to lack of optimization. It has been a popular subject for the last 35 years or so. Most studies have focused on mixing times, flow patterns and power draw in turbulent regime. However, many industrial mixing operations are carried out at low to moderate Reynolds numbers, where turbulence cannot be achieved. The presence of important segregated and dead zones has been observed when using open impellers such as Rushton turbines or propellers at low Reynolds numbers. Well-mixed regions have been observed around the impellers surrounded by stagnant fluid, which are known as caverns in the case of yield stress fluids. In the case of viscous Newtonian fluids agitated at low speed, two ring vortices are formed below and above the impeller.

Although flow patterns in stirred vessels have been visualized using several techniques reported in the literature, the easiest way to visualize such structures and flow non-homogeneities consists of using a non-intrusive technique

based on a fast acid/base reaction as described by Norwood and Metzner (1960). Such a technique has been also used to reveal the existence, locations and size of pseudocaverns and dead zones (Lamberto *et al.*, 1996) and for measuring mixing times in stirred vessels (Ascanio *et al.*, 2002). This technique provides information of the flow structures from a qualitative standpoint. Other flow visualization techniques, such as X-ray, have been used for measuring and predicting the cavern diameter with shear-thinning fluids (Nienow and Elson, 1988). Amanullah *et al.* (1998) developed a mathematical model to predict cavern diameter in pronounced shear-thinning fluids. Their model can be applied to predict the diameter of caverns generated by both axial flow and radial discharge impellers.

It has been demonstrated that both the well-mixed regions as well as the isolated ones can be readily destroyed if the flow is continuously perturbed. The principle of hydrodynamic perturbations is to bring additional degrees of freedom allowing chaotic mixing to take place. Earlier work showed that homogenization could be improved when eccentric cylinders rotating in both directions during short times were used (Ottino 1990, Swanson and Ottino 1991, Muzzio *et al.* 1991, 1992) or the geometry was changed periodically. Lamberto *et al.* (1996) applied this approach with a time-dependent rotating impeller. They clearly demonstrated that mixing is enhanced if the flow is continuously perturbed, preventing the formation of coherent segregated regions in the vicinity of the impeller, confirming the theoretical results in the seminal paper by Aref (1984) on chaotic mixing, the work of Franjone *et al.* (1989) and the numerical results by Aref and Balachandar (1986). Lamberto *et al.* (1999) highlighted numerically the existence of two ring vortices above and below the impeller. The position and size of these segregated regions were found to depend on the value of the Reynolds number and the position of the impeller blades. Using the same experimental technique, independent research (Alvarez 2000, Brito *et al.* 1999) found that mixing times could be reduced when combining dynamic flow perturbations and impeller offsetting, which was later confirmed by Alvarez *et al.* (2000) in a numerical and experimental study on the use of eccentric impellers and time-dependent rotations. It should be mentioned that this approach is the one that we all follow when

we want to blend difficult-to-mix ingredients in the home kitchen with a hand blender!

Recently (Ascanio et al 2002), the mixing performance of eccentric impeller and dual mixers consisting of two independent mixers rotating in the same vessel was experimentally studied. It was found that flow compartments and segregated regions could be destroyed, and mixing times and the power draw could be significantly reduced as compared with the standard configuration and operating mode, paving the way to a completely new approach for viscous mixing stirred tanks.

This paper describes an experimental development for observing the flow structures generated under steady and unsteady mixing conditions in a stirred vessel

NOMENCLATURE

h	[mm]	Liquid height
H	[mm]	Vertical impeller position
T	[mm]	Vessel diameter
x	[m]	Eccentricity

Special characters

μ	[Pa s]	Fluid viscosity
ϕ	[m]	Impeller diameter
ρ	[kg/m ³]	Fluid density

MATERIALS AND METHODS

Figure 1 shows the experimental setup, which consists of a transparent polycarbonate vessel of 165 mm in diameter and 210 mm height and a square jacket. In order to avoid considerable refraction index changes the jacket was filled with the same fluid under study. A radial discharge impeller (Rushton turbine) was used for the experiments. The impeller was mounted on a rigid shaft driven by DC motor, which speed is set and carefully controlled with a DC control. A non-contact tachometer was used for registering the agitation speed. The mixer frame was placed on a rigid metallic frame allowing the impeller to place in a specific radial position.

Newtonian solutions were used in the present work. Aqueous solutions of pure glycerine (99.5% USP) having a density of 1250 kg/m³ and corn syrup at 90 wt% dissolved in water. The viscosity of both solutions was 1.4 Pa·s.

The flow patterns into the stirred vessels were visualized by two different techniques, namely planar laser induced fluorescence (pLIF) and the particle image velocity (PIV). A Nd:YAG laser having a energy of 120 mJ was used as illumination source. For that purpose, in both cases an optical array was used in order to create a light sheet of less than 1 mm width, so that the stirred vessel was illuminated in a specific plane. A digital video recorder was used to capture images of

the illuminated plane. In the case of pLIF tracer solution was prepared with 15 mg of rhodamine B dissolved with 50 ml of pure glycerine and this solution was added to the tank with the impeller at rest. For PIV experiments, silver covered hollow spheres having a diameter of 10 μm were used as particle tracers. In such a case, 6 mg of H-SGH (Dantec Dynamics, Inc.) were added for each litre of the solution under test. The impeller was placed at 1/3 of the liquid height, which is a typical scenario used elsewhere. The impeller steady rotated in all the experiments at 37 rpm giving a Reynolds number of 1.6, so that the experiments were performed at laminar regime.

The flow visualization experiments with pLIF were recorded in the once the flow structures begin to form. For PIV experiments, the images were recorded once the hydrodynamic steady conditions were reached into the tanks and the flow structures generated by the impeller were observed and remain stable. Mixing experiments were performed at room temperature ($\sim 24^\circ\text{C}$).

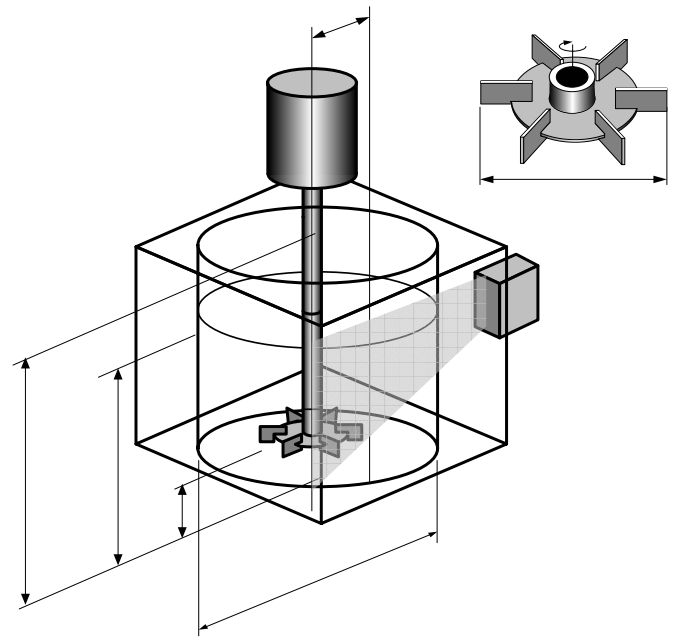

Figure 1 Experimental setup (dimensions in mm)

RESULTS

Figure 2 shows a cross-section of the flow pattern observed with pLIF. In this case, the tracer solution was added to the tank with the impeller at rest and then the mixer was turned on and the flow structures begin to form. As figure 2 shows, two ring vortices were formed above and below the impeller, which is in good agreement with previous results obtained elsewhere (Lamberto et al, 1996; Ascanio et al, 2002). Because the impeller is placed closer to the vessel bottom the ring vortex formed below the impeller is smaller than the one formed

above due pumping action of the impeller, even if its flow discharge is in the radial direction.

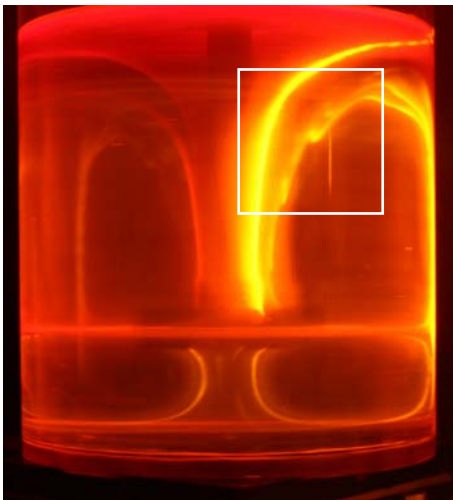

Figure 2 **Flow patterns observed with pLIF in steady conditions**

It is important to observe the ring vortex formed above the impeller. If one takes a look at the region in the square, a complex structure is formed even under steady stirring conditions. Although a slight displacement of the agitation shaft with respect to the vessel axis of symmetry may generate a chaotic flow, the structure observed in figure 1 leads to think that flow into the vessel is spatio and time-dependent. There is no evidence about such a statement, however, it is believed that the flow can be chaotic for certain period.

On the other hand, the PIV is a very useful technique for obtaining the velocity fields. However, it provides important information about the flow fields, which cannot be obtained by other techniques such as a colorimetry or pLIF. Figure 3 shows the flow field observed under the same experimental.

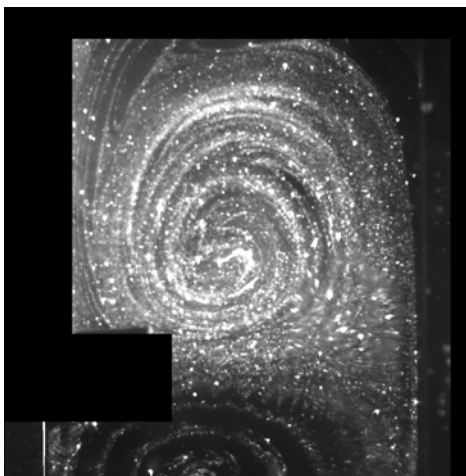

Figure 3 **Flow patterns observed with PIV in steady conditions**

In the present case, the camera was focused mainly on the flow structure formed above the impeller. As figure 3 shows, PIV reveals not only the vortex observed with pLIF, but also a spiral formed into the structure. The main paths of the tracer particles lead to the think that hollow spheres interact between them as it occur when mixing suspensions, which is the typical case of colloidal forces. The preferential paths followed by the trace particles show that the phenomenon is three-dimensional. Then, a planar analysis is very limited to state that the flow is chaotic. However, more work is needed to provide enough evidence of this fact.

Figure 4 shows the corresponding velocity field obtained when the blade turbine was perpendicular to the camera, so that the radial discharge was the maximal.

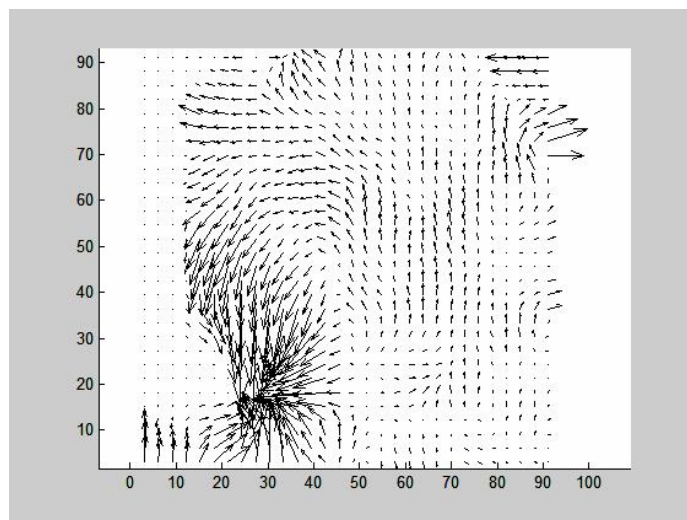

Figure 4 **Velocity field under steady conditions**

As the agitation shaft is slightly displaced from the vessel centreline the fluid contained into the tank can be thoroughly mixed (Ascanio et al, 2002). However, there is no big difference between the flow field with the impeller centered or eccentric, especially at very low Reynolds numbers. The difference between the two scenarios is observed as the flow structures above and below the impeller approach to the vessel wall. On the ring vortices touch this wall, the flow becomes chaotic and the fluid is completely homogenized into the tank. As a consequence, less energy is required and the process is more efficient.

Figure 5 shows the flow patterns observed with PIV under unsteady stirring conditions with the impeller displaced 5 mm only with respect to the vessel centreline. As it mentioned before, no big difference is observed in this flow pattern because of the Reynolds number used in both experiments was very low ($Re = 1.6$). Also, the ring vortex did not touch the vessel wall, then the flow structures displaced from the vessel centreline the same distance of the agitation shaft.

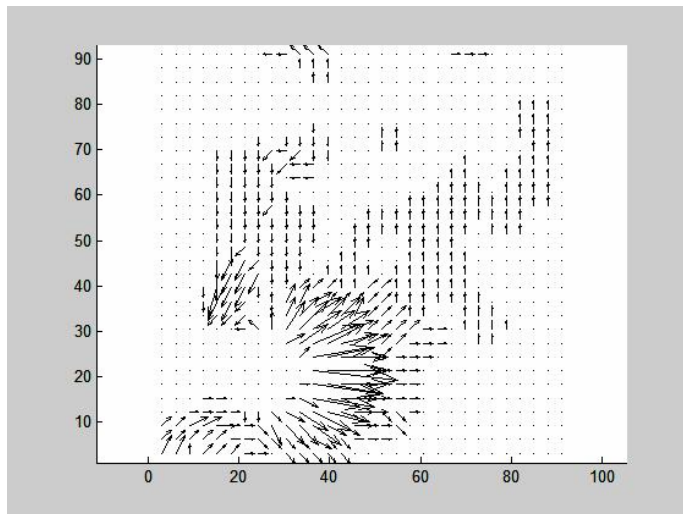

Figure 5 Velocity field under unsteady conditions

CONCLUSIONS

Flow patterns in stirred vessels under steady and unsteady mixing conditions were experimentally visualized. For the steady conditions, the impeller was centered and it rotated in one direction, while in the unsteady mixing scenario, the impeller was slightly displaced from the vessel centreline. Such a displacement has been proved to enhance the quality of mixing in stirred vessels; the reader is referred to the paper of Ascanio et al (2002) for more details. Although, this work was done considering two-dimensional flow, very complex flow structures were formed above and below the impeller, which leads to consider a three-dimensional phenomenon.

ACKNOWLEDGEMENTS

The financial support of DGAPA-UNAM through the grant IN-102405 is gratefully acknowledged.

REFERENCES

- [1] Norwood K.W. and Metzner, A.B., Flow patterns and mixing rates in agitated vessels, *AIChE J.* 6, 432-437 (1960).
- [2] Lamberto, D.J., Muzzio, F.J., Swanson, P.D. and Tonkovich, A.L., 1996, "Using time-dependent RPM to enhance mixing in stirred vessels", *Chem. Eng. Sci.*, 51, 733-741.
- [3] Ascanio, G., Brito-Bazán, M., Brito-de la Fuente, E., Carreau, P.J. and Tanguy, P.A., Unconventional configurations studies to improve mixing times in stirred tanks, *Can. J. Che. Eng.* 80, 558-565 (2002).
- [4] Nienow A.W. and Elson, T.P., Aspects of mixing in rheologically complex fluids, *Chem. Engng. Res. Design*, 66, 5-15 (1988)
- [5] Amanullah, Hjorth, S.A. and Nienow, A.W., A new mathematical model to predict cavern diameters in highly shear thinning power law liquids using axial flow impellers, *Chem. Eng. Sci.* 53(3), 455-469 (1998).
- [6] Ottino J.M., 1990, "Mixing, chaotic advection and turbulence", *Ann. Rev. Fl. Mech.*, 22, pp. 207-253.
- [7] Swanson P.D. and J.M. Ottino, 1991, "A comparative computational and experimental study of chaotic mixing of viscous fluids", *J. Fluid Mech.*, 213, pp. 227-249.

- [8] Muzzio, F.J., P.D. Swanson and J.M. Ottino, 1991, "The Statistics of Stretching and Starting in Chaotic Flows", *Phys. Fluids A*, 3, pp. 822-834.
- [9] Muzzio, F.J., C. Meneveau, P.D. Swanson and J.M. Ottino, 1992, "Scaling and Multifractal Properties of Mixing in Chaotic Flows", *Phys. Fluids A*, 4, pp. 1439-1456.
- [10] Aref H., 1984, "Stirring by chaotic advection", *J. Fluid Mech.*, 143, pp. 1-21.
- [11] Franjone, J.G., C.W. Leong and J.M. Ottino, 1989, "Symmetries within Chaos: A Route to Effective Mixing", *Phys. Fluids 1*, pp. 1772-1783.
- [12] Aref H. and S. Balachandar, 1986, "Chaotic advection in a Stokes flow", *Phys. Fluids*, 29, pp. 3515-3521.
- [13] Lamberto, D.J., M.M. Alvarez and F.J. Muzzio, 1999, "Experimental and Computational Investigation of the Laminar Flow Structure in a Stirred Tank", *Chem. Eng. Sci.*, 54, pp. 919-942.
- [14] Alvarez M.M., 2000, "Using spatio-temporal asymmetry to enhance mixing in chaotic flows", *PhD thesis, The State University of New Jersey, Piscataway.*
- [15] Brito-De La Fuente, E., S. Hernández, A. Segura, L. Medina, P.A. Tanguy and G. Ascanio, 1999, "Laminar Mixing in Stirred Tanks using Dynamic Perturbations and Non-Symmetric Geometry Conditions", in *Applied Mechanics in the Americas* 6, , pp. 155-158.